

POPULAR COMMUNICATIONS

APRIL 1997

Satellite Digital Audio— A Step Closer to Reality

- Can Naturally-Generated Signals Predict Earthquakes?
- Joseph Murgas—Radio's Overlooked Genius
- Spotlight on The Lowe SRX100 Shortwave Receiver
- Computer Corner Reviews Scancat—Gold for Windows

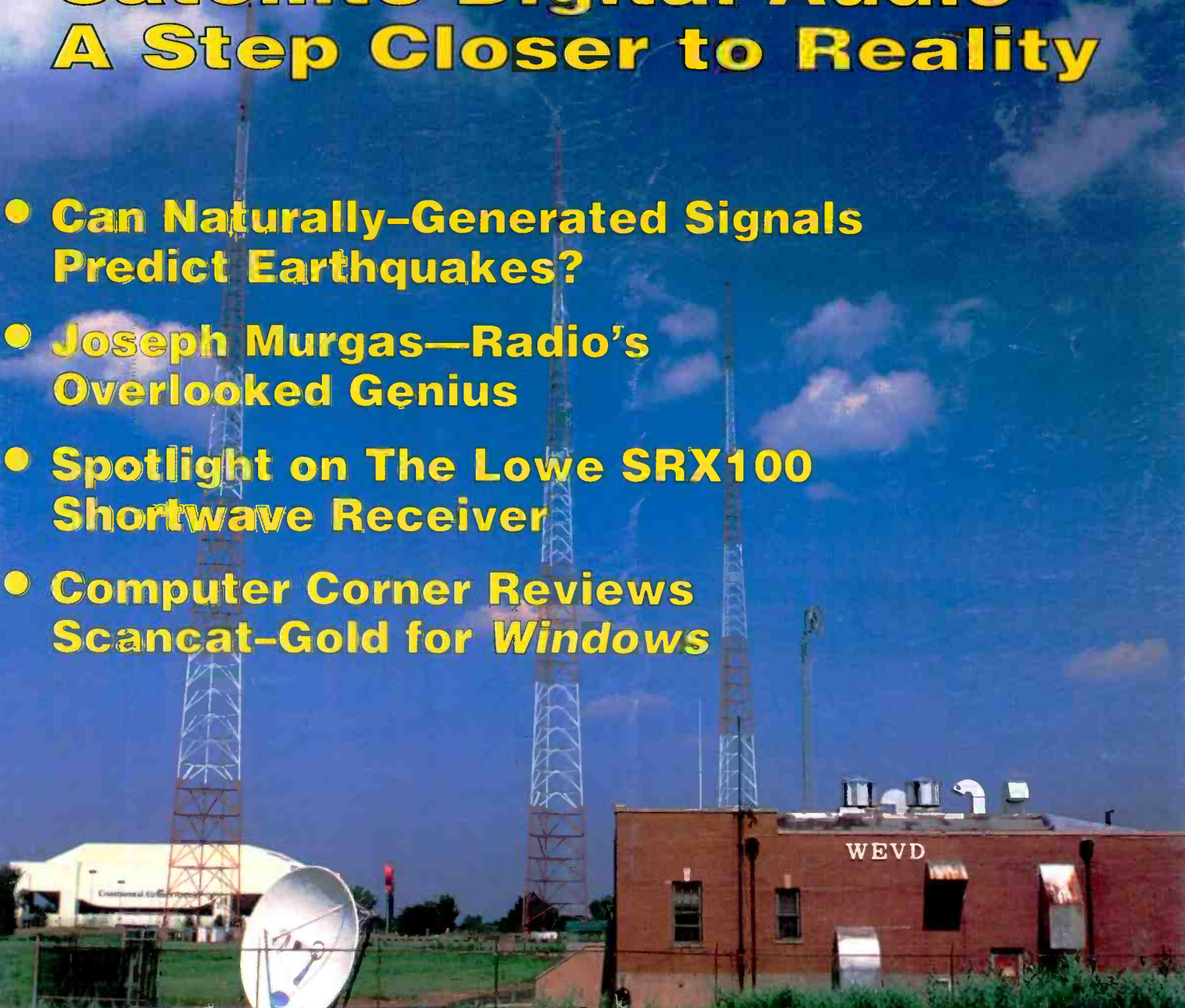

U.S. \$3.50 CAN

*****3-DIGIT 641
02 00380028 FEB98 9704N ASH

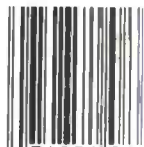

MR. DAVID C STEARNS
109 W 98 TER
KANSAS CITY MO 64114-4122

link, The Pirate's Den,
The Listening Post and MUCH MORE!

AOR DOMINATES THE SCANNER MARKET

AR5000 Cyberscan

*The Professional Scanner 10kHz - 2600MHz**

AOR has advanced the frontiers of performance providing strong signal handling, high sensitivity and the widest coverage on the market. Advanced wide band front end design provides high sensitivity with auto tuning pre-selector from 500kHz to 1000MHz, plus manual override to read signal and store setting in memory.

Every function of the AR5000 is micro processor controlled and receives instructions direct through the front panel or via RS232. I.F. filtering is unique. Filter selection controls 2 banks of filters, one at 10.7 MHz the other at 455kHz. This cascade filtering effect produces excellent shape factors and ultimate out of band signal rejection. There are 6 filter bandwidths provided 3,6,15,30, 10, 220kHz with a seventh position for optional 500Hz cw filter in the 455 kHz IF. There are 1000 memory channels in 20 banks plus 20 search banks and an of 2100 pass frequencies.



AR8000 - New Concept

AOR made every effort to incorporate the latest technology into this scanner:

The Ultimate Handheld Receiver! "Welcome to the world of the AR8000". It incorporates the latest PLL technology and offers a multitude of features including true carrier re-insertion SSB (CW) demodulation with 50Hz frequency steps. 4 level alpha numeric LCD indicates the frequency, signal strength, band scope and more. Selectable squelch system, auto-mode, auto-band plan, serial communication port are all standard. Internal ferrite antenna offers high performance reception below 2MHz. When frequencies are entered, ALPHANUMERIC comments may be stored along with the frequency, mode & attenuator status simplifying the job or recalling and identifying memory channels.

- Covers .1 - 1900MHz*
- Ferrite rod antenna below 2MHz
- Only portable scanner on the U.S. market to have true SSB, both LSB & USB.
- 4 level alpha numeric LCD read out frequency, mode, signal strength, band scope spectra display, battery low, remote and more.
- Computer control up/down data load.
- Share your memory banks with a friend. load 1000 memory channels in seconds.
- Modes: AM/FM/WFM/USB/LSB/CW
- Stepsize: 50MHz to 995.995kHz
- Memories: 20 banks=1000 total
- Size/Weight: 6.1" x 2.6" x 1.5"/12.2oz. w/ NiCad

AR3000A - 100kHz-2036MHz*

The Most Respected Scanner on the Market!

Compact, low cost wide band multi-mode reception. Small size has allowed the AR3000A to be used in many applications from battery powered brief case to multi-receiver rack-mounted installation to air born EWA systems. The AR3000A has proved itself as an easy to operate, rugged, low-cost and reliable contender for many requirements.

- Coverage: 100kHz-2036MHz*
- Modes: FM, FMW, AM, LSB, VSE, CW
- Memory: 400 CH 4 banks • Scan Speed: up to 50 CH/Sec.
- Sensitivity: NFM 2.5-1.800MHz 35NV
- Selectivity: 2.4, 12, 180 KHz • Antenna: BNC 50 Ω
- Power: 13.8VDC<5A AC Adapter included • Size: 5.4 x 3.15 x 7.9", 2.4 lbs



AOR, LTD.
2-6-4 Misuji,
Taito-Ku, Tokyo
111 Japan (c) 1995
AOR, LTD.
Licensed under
US. Pat. 4,270,217

*** Cellular blocked;
Unblocked OK to
FCC approved
users.**



Electronic Distributors
325 Mill Street
Vienna, VA. 22180
phone: 703.938.8105
FAX: 703.938.4525
www.elecdist.com



U.S. #1 RADIO OUTLET

OUR 25th YEAR!!!

APRIL '97



SCANNER SALE

AOR		
AR8000 ¹	BearCat	587.95
BC120XLT		139.95
SC150Y/B		169.95
BC230XLT		239.95
BC235XLT		CALL
BC3000XLT		369.95
BC9000XLT		379.95
BC890XLT		229.95
BCT12	800MHz NEW!	189.95
ICOM		
R10 ¹⁻²	NEW!	499.95

SHORTWAVE SALE

GRUNDIG		
YB400		174.95
YB305		116.95
Traveller II Digital		89.95
SANGEAN		
ATS 606P		169.95
ATS 808		139.95
ATS818		149.95
ATS909		259.95
SONY		
ICFSW40		149.95
ICFSW100S		349.95
ICF2010		359.95
ICFSW7600G		169.95
AOR		
AR3030G		913.95
AR7030		1149.95
LOWE		
HF150		499.94
HF250		1149.95
DRAKE		
SW1		279.95
SW8		679.95
R8A		1079.95

CB RADIO SALE

COBRA*		
HH70		96.95
2010GTL		339.95
CHEROKEE*		
AH27		119.95
CM5		99.95
AH100	NEW!	249.95
CBS1000	NEW!	279.95
MIDLAND*		
79-290		249.95
75-810		119.95
75-784		69.95

*Only partial listing...
CALL for other models and all accessories are discounted.

1. Cell blocked, no blocks OK for FCC qualified users
2. At press time the R10 had not been FCC certified.

NEW FAMILY RADIO

It's all in the family!

- NEW Family Radio Service (FRS).
- LICENSE FREE
- Push & Talk up to 2 miles.
- Crisp clear audio.
- No monthly fee!

Small walkie-talkies as low as \$109.95

MAXON FRS114	CALL
MIDLAND 75-510	\$149.95
MOTOROLA Sport7*	\$119.95
MOTOROLA Sport7X*	\$139.95

* Buy 2 or more and save!

Available in black, camo, green & blue



APRIL ONE WEEK SPECIAL
APRIL 23 TO 29, 1997

NEW SRX100 from LOWE

Nothing like it in this price range. 30kHz-30MHz, AM, USB, LSB, CW, LCD readout. Easy operation, 1kHz tuning, internal speaker, dual conversion. Small and compact, 7.3"x 7.5"x 2.5".

12VDC with AC adaptor included.

Regular discount price **\$299.95**,
1 week only **SAVE \$50.00**



\$249.95

FREE headphones incl.



APRIL 23 TO 29, 1997

DAVIS Weather Wizard III
It's that time of year again when everyone needs a weather station. The DAVIS WEATHER WIZARD III provides all the WX information you need. #7425



SALE \$169.95

WATSON
Antennas designed for best reception. Extend your range. All cover 25MHz-1900MHz with BNC connectors.



W801 \$19.95
W881 \$29.95
W889 \$19.95

GE SUPERADIO II
Puts the fun back in AM/FM DX'ing. Larger ferrite rod antenna, 4 I.F. stages. Every one needs this great sounding radio.



SALE \$59

Sound Feeder
Want the best way to hear your scanner, HT, CD? Use the SF100 to hear thru your FM car radio. Tune to clear channel, also charge/run your unit from its lighter plug. Easy Hook up. List \$39.95



SALE \$28

AOR AR5000

NOTHING LIKE IT IN IT'S CLASS

- 10kHz - 2600MHz*
- Superior Sensitivity
- Cascade I.F. filtering
- 6 Filter B.W. +1 Opt.
- Memory 1000 + 2100 pass
- Option CTCSS and Voice Inversion
- 2 Ant. ports, Opt. to 8 ports
- Scan/Search 258 & 45 ch/sec.
- RS232C of all functions
- Built-in decoder DTMF
- Price class \$2000



* Cell BLOCKED; UNBLOCKED models OK for FCC approved users.

Call for FREE 4 page detailed flyer w/ R8500 comparison

MITRONICS COUNTERS

- Hi Speed 250MHz Direct Counter
- 10 digit LCD display
- 16 segment signal bar
- 1ppm time base
- 6 hour w/ included NiCads
- AC Adaptor included



- MODEL MIC1028**
- Range 10MHz-2.8GHz
 - IMP. 1meg<50MHz, 500HM>50MHz
 - Freq. period, auto trigger & hold Compare @ 229 **SALE \$195**
- MODEL MIC10C28**
- Range: 1 - 2800MHz
 - IMP. 50 Ohm
 - Sensitivity @ 100MHz <1mV Compare @ 149 **SALE \$125**

Telescoping antenna included \$19.95 Value !!!

ICOM R8500

IT'S NEW...IT'S FANTASTIC

- 100kHz - 2000MHz*
- Improved Audio
- 4 Filter B.W.
- Memory 900 + 100 pass
- RS232 and CI-V Control
- (2) HF Antenna ports (1) VHF/UHF
- Auto Freq. control
- Audio Peak Filter
- Pass Band Tuning
- Price Class \$2000



* Cell BLOCKED; UNBLOCKED models OK for FCC approved users.

CALL FOR QUOTE



323 Mill St.
Vienna, VA.
22180
FAX: 703 - 938 6911

Orders: 800 368 3270
INFO/Metro: 703 938 3350
WWW: www.access.digex.net/eeb
E-mail: eeb@access.digex.net

- Prices subject to change
- Prices do not include freight
- Returns subject up to 20% restock fee
- FREE 1996 Catalog, 3rd Class, U.S.



POPULAR COMMUNICATIONS

APRIL 1997

VOLUME 15, NUMBER 8



page 18



page 44

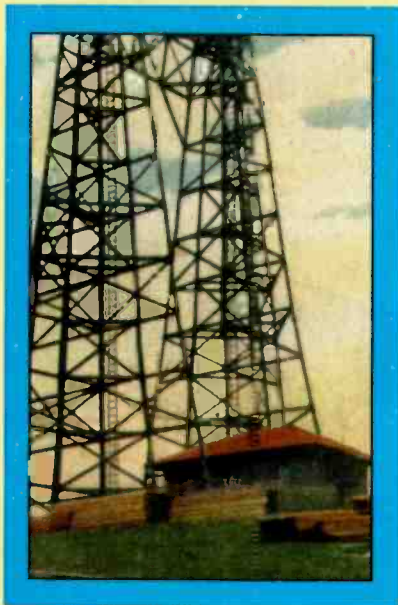

page 15

ON THE COVER: Radio station WEVD, 1050 AM stereo with towers located in the Meadowlands, NJ. News about stations like WEVD can be found every month in Tim Kridel's column "Broadcast DXing." See his column this month on page 54.



FEATURES

Scientists Discover Evidence of RF Geo-Electromagnetic Emissions Preceding Earthquakes

8

In the past two or three decades, a different form of naturally-generated radio signals has been detected. They may form the basis for a prediction system to guard against earthquakes, tornadoes, etc.

By Amnias Lueter, Ph.D

Radio's Overlooked Genius

15

Is it possible that Joseph Murgas could have been more of a wireless pioneer than Marconi even though most of us have never heard of him?

By Alice Brannigan

Broadcast DXing—**Satellite Digital Audio**

54

Satellite-delivered digital audio takes a step closer to reality, WRVA continues its goal to be the best, and East End radio stations change hands. Keep up-to-date with the fast-paced world of Broadcast DXing with the help of Tim Kridel.

By Tim Kridel

Product Spotlight

60

Looking for a shortwave receiver? Find out if the Lowe SRX100 is right for you!

By Peter J. Bertini

COLUMNS

The Radio Connection	18
The Pirate's Den	22
Books You'll Like	24
Radio Resources	27
The Computer Corner	30
Scanning The Globe	35
Clandestine Communiqué	38
World Band Tuning Tips	40
Product Parade	42
The Listening Post	44
CB Scene	50
ACARS Downlink	63
Communications Confidential	68
The Ham Column	76
Washington Pulse	77
The Loose Connection	80

DEPARTMENTS

Tuning In	4
Pop'Comm P.O.	6
How I Got Started	53
Reader's Market	78

QUALITY COMMUNICATIONS EQUIPMENT SINCE 1942



Shortwave Receivers Past & Present is your guide to over 500 communications receivers made from 1945-1996. This huge 350 page Second Edition includes 80 chapters representing: Collins, Cubic, Dansk, Drake, Eddystone, Galaxy, Gonset, Hallicrafters, Hammarlund, Heathkit, Icom, JRC, Kenwood, Knight, Lowe, Mackay, McKay Dymek, Morrow, National, Plessey, Racal, RME, Rohde & Schwarz, Sony, Squires-Sanders, Ten-Tec, Vigilant, W-J, Yaesu and many more. Entry information includes: receiver type, date sold, photograph, size & weight, features, reviews, specifications, new & used values, variants, value rating and availability. Become an instant receiver expert! #0002 \$19.95 (+\$2)

COMMUNICATIONS RECEIVERS



Universal Radio carries an excellent selection of new and used communications receivers. JRC NRD-535D shown.

RTTY AND FAX DECODERS

◆ Universal M-8000v7 Decoder

Designed primarily for the military or commercial user, the M-8000 can be used



by the hobbyist who requires professional capability. The color VGA output includes a spectral display & simulated tuning scope. Modes include: CW, Baudot, FAX, SITOR, ARQ-M2/4, ARQ-E/E3, ARQ6-90, ARQ-S, SWED-ARQ, FEC-A, FEC-S, POL-ARQ, GMDSS, ASCII, Packet, Pactor, Piccolo, VFT, ACARS, POCSAG & GOLAY. Monitor & printer optional. #0087 \$1399.00 (+\$11)

◆ Universal M-450 Reader



The self-contained Universal M-450 reader decodes: Baudot, SITOR A & B, FEC-A, ASCII, SWED-ARQ, Weather FAX (to the printer port), ACARS aviation teletype, plus GOLAY and POCSAG (512/1200/2400) digital pager modes. Even off-the-air decoding of DTMF, CTCSS and DCS. Big two-line, 20 character LCD and bid-dir. parallel printer port. The M-450 runs from 12 VDC or with the supplied AC adapter. No computer or monitor is required. Now with serial port. #0450 \$399.95 (+\$8)

SPECIALTY



The BayGen Freeplay radio combines the ingenious Baylis generator with the latest in radio technology. Winding the crank handle for only 20 seconds provides 30 minutes of listening. Here is assured radio performance, day or night without the worry (and expense!) of batteries. Great for emergencies. The analog dial covers AM, FM and shortwave from 3000 to 12000 kHz. Made in South Africa. #3123 \$99.95 (+\$5)

HUGE FREE CATALOG

The **Universal Communications Catalog** covers everything for the shortwave, amateur and scanner enthusiasts. With prices, photos and informative descriptions. This 100 page catalog is **FREE** by bookrate or \$2 by First Class mail. Rising postage costs prevent us from sending this catalog out automatically so please **request your free copy today!**



COMMERCIAL RECEIVERS



The Watkins-Johnson HF-1000 is the ultimate receiver! Advanced D.S.P. technology, 58 bandwidths, 1 Hz display. Under \$4000. Please contact us to receive a spec. sheet.

PORTABLE RECEIVERS



Universal offers over 40 portable receivers from \$50 to over \$500. Our free catalog fully describes & prices all models.

COMMUNICATIONS BOOKS

- **Passport To Worldband Radio 1997** By L. Magne
Graphic presentation of all shortwave broadcast stations. Equipment reviews, too. #1000 \$19.95 (+\$2)
 - **World Radio TV Handbook 1997**
All shortwave broadcast stations organized by country with schedules, addresses, power, etc. #2000 \$24.95 (+\$2)
 - **Worldwide Aeronautical Frequency Dir.** By R. Evans
The definitive guide to commercial and military, HF and VHF-UHF aeronautical communications including ACARS. Huge Second Edition 260 p. #0042 \$19.95 (+\$2)
 - **Guide to Utility Stations** By J. Klingenfuss
Clearly the best guide to non-broadcast HF stations. With 13,800 current frequencies. 585 p. #2019 \$39.95 (+\$2)
 - **Discover DXing!** By J. Zondlo
An introduction to DXing AM, FM & TV. #0009 \$4.95 (+\$2)
 - **Understanding ACARS** By E. Flynn
Learn the ACARS aviation format. #0012 \$9.95 (+\$2)
- ☛ Be sure to include \$2 per title for shipping.

SPECIALS

- **Grundig YB-400 LW/MW/SW/FM Digital Receiver**
Rated "Best performance for price/size category" in *Passport*. Features: full coverage, keypad, wide/narrow selectivity, clocks, SSB and 40 memories. \$169.95 (+\$6)
Get 3 **FREE BONUS** items: • Universal Radio Stand
• DX Tips for Beginners • Radio Propagation for Beginners
- **Drake SW-1 LW/MW/SW Digital Receiver**
This great sounding set has keypad entry and 32 memories. New optional car bracket. **Call for a great price!**

Universal Radio, Inc.
6830 Americana Pkwy.
Reynoldsburg, Ohio
43068-4113 U.S.A.

☎ 800 431-3939 Orders & Prices
☎ 614 866-4267 Information
→ 614 866-2339 FAX Line
✉ dx@universal-radio.com

VISIT UNIVERSAL RADIO ON THE INTERNET
<http://www.universal-radio.com>

- Visa
- MasterCard
- Discover
- Prices and specs. are subject to change.
- Returns subject to a 15% restocking fee.
- Used equipment list available on request.



Tuning In

AN EDITORIAL

A Modest Proposal—To Save Ham Radio

By Jock Elliott, KB2GOM

Editor's note: As I mentioned a few months ago, from time to time we'll be giving you an opportunity to sound off about your views on our radio hobby. This month, Jock Elliott, KB2GOM one of our CB Scene columnists, offers his thoughts on the state of ham radio.

Starting about two years ago, there has been a rising concern about the future of ham radio. "Cell phones and the Internet are eating our lunch," we moan, "and the barbarians are at the gate." Make no mistake, we are in trouble. We suffer from an embarrassment of riches in terms of RF spectrum. If I am counting correctly, hams in the U.S. have privileges on 15 bands. There are only about 660,000 licensed amateurs in the country, about one-fourth of a percent of the total U.S. population. If each of us spends an hour a day on each band (leaving us little time for anything else), I doubt that would be a convincing demonstration of spectrum occupancy.

Most old-timer hams I know are steadfastly grumpy (still!) that the 11-meter band was taken away from them and given to citizens band. But most conveniently forget why that chunk of spectrum was taken away . . . it was virtually unused by the amateur community. And whatever else you might say about CB, that piece of the spectrum is occupied. Some of the other bands are similarly unused right now. We're a bit like a car collector who won't let someone else drive his classic Duesenberg . . . just in case he wants to drive it some time.

And, just for the record, the hand-wringers are right: cellular phone is cheaper and more reliable for personal communications, and the Internet beats the pants off digital ham radio for global communications. So, is there any good news? Indeed there is, but most analyses haven't even mentioned it.

A Sense of Community

First, ham radio offers a real-time sense of community. When I switch on my two-meter rig on 145.17 in Troy, New York, I know instantly I'm among friends—the good folk of the Troy Amateur Radio Association. I recognized the voices before

I hear the call signs, and they recognize mine. We not only know each other, but we *care* about each other. "Hey, did you get your boat fixed?" "Is your Mom out of the hospital?" "I think I know what's wrong with your packet set-up." It's an on-the-air community that produces a sense of belonging that can't be duplicated by non-real-time communication displayed on a computer monitor or the selective one-to-one communication of a cell phone.

Second, ham radio offers incredible potential—not all of it yet realized—for public service. A late night this past November serves as a shining example. A snow/ice/freezing rain storm was clobbering our area. There were dozens of road accidents; people injured; trucks jack-knifed; roads closed. Yet, at the same time, hundreds of hams and CBers were participating in evening commuter net. The hams were operating on the 145.33 repeater operated by the Niagara Mohawk Amateur Radio Club, and the CBers were operating on Ch. 9. For nearly three and a half hours, information surged across the networks, getting help for the injured and disabled, for cars off the road, notifying authorities of fresh accidents and—perhaps most important of all—sharing information with the members of the networks so they could avoid the trouble spots and not add to the problem. This would have been impossible to do with the Internet. With cellular phones, necessary information could have been reported to authorities, but it wouldn't have been shared with other members of the net. Incidentally, a fair number of hams in our area have chosen to reinstall CBs in their vehicles. As a result, cross-band sharing of information is more readily possible.

So, how would I save ham radio? By playing our two strongest cards: community and public service. Ham clubs ought to do more outreach to the public and should make a concerted public relations effort a priority. There are whole two-meter-capable families who are members of the Troy club, but I have never seen it publicized. We need to remove some of the mystery surrounding our hobby and emphasize that it involves people talking to people.

When it comes to public service, hams already do a lot of good stuff, but nobody

knows because no one has bothered to tell them. A quick example: When the Olympic torch passed through Troy, it was hams who provided coordinating communications, but I saw no mention of it in the papers.

Finally, here are two proposals which are likely to draw more heat than light. First, Morse code should no longer be a requirement for any level of licensing. Given that it is not even used by the Coast Guard any more, requiring it for any license is simply a form of hazing, a rite of passage whose relevance has passed. I think, however, that the current band plan should be enforced. That way, CW competence becomes its own reward: If you can operate code, you can operate in the CW subbands.

I think we should also reevaluate our current notions of incentive licensing. Like an employee who fears "out-placement," we hams should attempt to make ourselves as valuable as possible to our communities. As a result, I think we should seriously consider making additional licensing privileges not dependent upon technical knowledge as demonstrated by passing a test, but on hours of public service. In short, if you want more spectrum, prove you're more valuable to the community.

So here's the bottom line: By lowering the unnecessary barriers to ham radio, we can encourage more people to join us. By demonstrating our value to the community through public service, we can encourage people to keep us around.

"Lower Author/Experimenter Ken Cornell, W2IMB Silent Key

Low-frequency author and experimenter Ken Cornell of Point Pleasant Beach, NJ has died. He was 79. Cornell was perhaps, best known for *The Low and Medium Frequency Radio Scrap Book* series (the 10th edition was recently published). He also authored many articles over the years and was a frequent contributor to *Lowdown*, the newsletter of the Longwave Club of America.

OUT OF THIN AIR AND INTO THE THICK OF THINGS.



THE DRAKE R8A

The Drake R8A World Band Communications Receiver. Turn it on, tune it in, and as easy as that, you're hearing world events as they happen... uncensored and complete. And with the R8A's astounding clarity, it's almost as if you're there. In fact, no other communications receiver puts you closer to the action in even the most distant parts of the world.

If you're a hobbyist, you'll marvel at the R8A's simplicity of operation. If you're an expert, you'll admire the high-powered features. The Drake R8A offers superior performance in a complete package that includes built-in filters and other unique features that have made Drake the foremost name in world band communications. The R8A from Drake...you've got to hear it to believe it.

DRAKE, FOR A WORLD OF DIFFERENCE.

Order Now Risk-Free! 15-DAY MONEY BACK TRIAL

We are so confident you'll be impressed with the R8A's performance, we'll give you a full refund on your factory direct order, less shipping charges, if the R8A doesn't meet or exceed your expectations. Call for complete details.

Order Today, Factory Direct or call for the dealer nearest you **1-800-937-2538**



DRAKE

R.L. Drake Company, P.O. Box 3006, Miamisburg, Ohio 45343, U.S.A. • Sales Office: 513.866.2421 • Fax: 513.866.0806 • Service and Parts: 513.746.6990 • In Canada: 705.742.3122
© 1995 The R.L. Drake Company

DRAKE is a registered trademark of The R.L. Drake Company.

CIRCLE 114 ON READER SERVICE CARD

Pop'Comm P.O.

LETTERS TO THE EDITOR

Each month we select representative reader letters for our Pop'Comm P.O. column. We reserve the right to condense lengthy letters for space reasons and to edit to conform to style. All letters submitted must be signed and show a return mailing address or valid e-mail address. Upon request, we will withhold a sender's name if the letter is used in Pop'Comm P.O. Address letters to: Harold Ort, N2RLL, SSB-596, Editor, *Popular Communications*, 76 N. Broadway, Hicksville, NY 11801-2909, or send e-mail via the Internet to <popular.com@aol.com>.

Mom Said There Might Be Days Like This

Dear Editor:

I must take issue with something in your October issue—the article by Pat Murphy “The Pirate Radio Explosion” which appears to glorify the illegal practice of pirate radio. And yet in your September issue, Jock Elliott devotes a whole article to condemning the equally illegal practice of “freebanding.” Can we get our priorities straight here? Both practices should be and are illegal though “everybody does it.” As my mother used to say: “If everybody jumped off a cliff, would you?” As a ham, I feel that both the pirates and out-banders, some of whom are planning on a hostile takeover of the 10-meter band, according to a bit of news I heard on 80 meters—pose a threat to we legitimate users of the amateur 10-meter and 40-meter bands.

Rich Klingman, KB2NDK
Mt. Upton, NY

Dear Rich:

Does pirate radio harm anyone? No. Is it illegal? Yes, most certainly! Are we condoning it by having a monthly column dedicated to listening to these stations or by giving readers the “inside scoop” on how these folks set up their stations? Not at all. We at *Pop'Comm* have always believed that our readers are the driving force behind what's covered in our magazine. Our recent survey shows a high interest in pirate radio; enough to warrant more pirate features and photos in the coming year. My priorities are to give our writers the freedom to express their views on many interesting radio topics. That includes pirate radio and freebanding.

Certainly everybody, and our colum-

nists are no exception, has an opinion on this touchy subject. Neither Jock Elliott or his co-columnist, Ed Barnat have ever been proponents of freebanding, but they will be reporting on the subject. And again, just because they're illegal activities doesn't mean they aren't interesting and enjoyable topics for many hobbyists, both hams and non-hams alike. I don't know about the rest of the radio community, but I don't feel any more threatened by these pirates and freebanders than I do of the little old lady down the street waving her cane at the traffic.

Somehow you have the mistaken impression that “everybody does it,” which is far from the truth. While it may seem like there are countless pirates and freebanders on the air, in reality there are fewer of them than there are legal hams who stretch the rules to the limits. The real threat isn't from the illegal pirate or freebander, it's from the few licensed highly visible operators who have forgotten what on-air ethics and working the world on a watt is all about. Think about it for a moment: When non-hams—your neighbors and other non-hobbyists think of radio operators, their image is of CBers and hams, not pirates or freebanders.

By the way, I haven't heard anything about a “hostile takeover of the 10 meter band.” It wouldn't matter if I did, because just last week my mom told me not to believe everything I hear.

Fighting Back!

Dear Editor:

I read with interest the column by J.T. Ward in November's *Pop'Comm*. His premise of the government banning scanner radios is not all that farfetched. . . . judging the present political climate here . . . laws like this are not only possible, but are probable. Look at the cellular ban, the “V” chip, and the Computer Decency Act. Orwell's predictions of “1984” didn't quite come true, but we are getting there.

I disagree however, with the proposed solution that J.T. suggested of turning to the ARRL. There are several things wrong with that. Some would equate this move with the same as registering guns. Now the government knows where the scanner users are. They can come and get

(Continued on page 32)

POPULAR COMMUNICATIONS

EDITORIAL STAFF

Harold Ort, N2RLL, SSB-596, Editor

(Internet e-mail: PopularCom@aol.com)

Tom Kneitel, K2AES/KNY2AB, Senior Editor

Nancy Barry, SSB-931, Associate Editor

(Internet e-mail: NancyPCmag@aol.com)

Richard S. Moseson, NW2L, Online Coordinator

CONTRIBUTING EDITORS

Richard “RD” Baker, Utility Communications

Ed Barnat, TCA-44, CB SSB

Peter J. Bertini, K1ZJH, Restoration/Electronics

Joe Carr, K4IPV, Antennas

Gerry L. Dexter, Shortwave Broadcast

Jock Elliott, SSB-734, Citizens Band

Bob Evans, ACARS

Ed Griffin, Computer-Aided Radio

Chuck Gysi, N2DUP, Scanning

Kirk Kleinschmidt, NT8Z, Amateur Radio

Tim Kridel, AM/FM Broadcasts

Bill Mauldin, WG4R, Radio Resources

Pat Murphy, Pirate Radio

Don Patrick, CB Restoration

Bill Price, N3AVY, Humor/Communications

Edward Teach, Pirate and Alternative Radio

Bonnie Zygmunt, Computer-Aided Radio

BUSINESS STAFF

Richard A. Ross, K2MGA, Publisher

Donald R. Allen, W9CW, Advertising Mgr.

Emily Kreutz, Sales Assistant

Frank V. Fuzia, Controller

Catherine Ross, Circulation Manager

Melissa Nitschke, Operations Manager

Jean Sawchuk, Data Processing

Denise Pyne, Customer Service

PRODUCTION STAFF

Elizabeth Ryan, Art Director

Barbara McGowan, Associate Art Director

Edmond Pesonen, Electronic Comp. Mgr.

Dorothy Kehrwieler, Production Manager

Emily Kreutz, Assistant Production Manager

Pat Le Blanc, Phototypographer

Hal Keith, Technical Illustrator

Larry Mulvehill, WB2ZPI, Photographer

A publication of



CQ Communications, Inc.

76 North Broadway

Hicksville, NY 11801-2953 USA

Offices: 76 North Broadway, Hicksville, NY 11801. Telephone (516) 681-2922. FAX (516) 681-2926. Popular Communications (ISSN-073-3315) is published monthly by CQ Communications, Inc. Periodical class postage paid at Hicksville, NY and additional offices. Subscription prices (payable in U.S. dollars): Domestic—one year \$22.95, two years \$41.00, three years \$60.00. Canada/Mexico—one year \$32.95, two years \$61.00, three years \$90.00. Foreign Air Post—one year \$40.95, two years \$77.00, three years \$114.00.

U.S. Government Agencies: Subscriptions to Popular Communications are available to agencies of the United States government, including military services, only on a cash with order basis. Requests for quotations, bids, contracts, etc. will be refused and will not be returned or processed.

Entire contents copyright © 1997 by CQ Communications, Inc. Popular Communications assumes no responsibility for unsolicited manuscripts, photographs, or drawings. Allow six weeks for change of address or delivery of first issue.

Printed in the United States of America.

Postmaster: Please send change of address to Popular Communications, 76 North Broadway, Hicksville, NY 11801.

THE NEW HANDHELD PACSETER IS HERE!

ICOM R-10
Only \$499⁹⁵
 PLUS \$9.00 UPS
 2nd Day Shipping and Handling

- 500 kHz-1300 MHz (less cellular)
- 1000 memory channels
- On-screen "band scope"
- Zero-wait-state scanning
- Vastly superior to the R-1 which it replaces!

Be one of the first to get this marvel of technology, available now from Grove at a truly marvelous price!

This incredible, new scanner is light years ahead of the competition. Features continuous 500 kHz-1300 MHz (less cellular) frequency coverage, multimode (AM/WFM/NFM/SSB) reception, rotary tuning control, programmable tuning steps from 100 Hz-1 MHz, on-screen "band scope" (200 kHz span), 1000 channel non-volatile memory, computer control, and second-radio cloning—and these are just the beginning!

The sleek, compact, lightweight R-10 has large, easy-to-read—and touch—keys. Its revolutionary zero-wait-state scanning seeks and holds in readiness the next active frequency while you are listening to another signal! Wide-dynamic-range, triple conversion, tunable bandpass filters, and sharp selectivity assure dramatic improvement in interference-free reception.

Eight alphanumeric characters can be entered to identify any channel, and ten characters can be used to identify banks. Voice scan control skips unmodulated carriers. Scan memory channels by bank, mode, or program. High-contrast display and powerful, dual-function keyboard provide incredible options to suit your listening requirements. Noise blanker and automatic noise limiter provide double noise reduction. Sleep timer and programmable attenuator are additional advantages.

ACCESSORIES

ACC 74	CT-17 interface	\$134.95
ACC 03	OPC-478 computer interface cable	\$45.95
ACC 04	OPC-479 Cloning cable (R10 to R10)	\$17.95
DCC 05	CP-12 cigarette lighter cable w/noise filter	\$29.95
CAS 01	LC-140 Carrying case	\$29.95
SFT 01	CS-R10 Cloning software (use with ACC 04)	\$29.95
HDP 03	Lightweight Comm. Headphones	\$22.95

GROVE

GROVE ENTERPRISES, INC.
1-800-438-8155 US and Canada;
704-837-9200; FAX 704-837-2216
7540 Highway 64 West
Brasstown, NC 28902



ICOM

E-mail: order@grove.net; World Wide Web: www.grove.net

CIRCLE 172 ON READER SERVICE CARD

Scientists Discover Evidence of RF Geo-Electromagnetic Emissions Preceding Earthquakes

By Annanias Lueter, Ph.D

There are many sources of natural radio signals. Some of them are generated in well understood ways; static from lightning bursts, hydrogen line 1.3 GHz signals, 18 to 40 MHz noise signals from the planet Jupiter, pulsars in outer space, and (closer to home) VLF whistlers and spherics. These signals have been covered in detail (see references 1-3). In the past two or three decades, however, a different form of naturally-generated radio signals has been detected. They may form the basis for a prediction system that will guard the populace against earthquakes, tornadoes and sudden severe "microburst" thunderstorms. These signals are classified by physicists as Autologous Absorptive Events (A²E).

The scientific literature has reported several different forms of A²E. For example, for about 10 hours prior to the San Francisco earthquake of 1989, strong pulsating signals were noted on a frequency of 60 kHz. These signals were essentially continuous wave except for a curious 10 dB amplitude shift that seemed somewhat random to the observers. The amount of the amplitude shift remained a constant 10 dB, but the timing was variable.

Similarly, prior to the Northridge, CA earthquake, signals at 6 kHz, 11.56 kHz, 52 kHz, 20.23 MHz and 72 MHz were emitted, but these were of a totally random nature as might be expected by naturally-generated signals.

In 1977, a three-day series of killer tornadoes swept across the midwest from Kansas to central Ohio, killing a number of people and causing extremely high property losses. Scanner operators in the

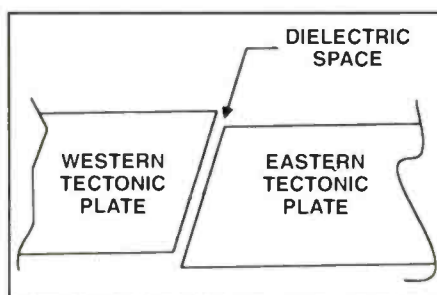

Fig. 1. The geo-capacitance mechanism.

path of the storm noted two phenomena that accompanied the storm.

One phenomenon (noted by 17 observers) was a sudden increase in the amplitude of received VHF and UHF signals at distances west of the observer. This is not believed to be an A²E, but rather something akin to meteor scatter or sporadic-E propagation. The electrical energy in the storm front acted like a radio reflector. This was indicated by the fact that the transmitting stations and receiving sites were always on the same side of the storm track, and the included angles were suggestive of the angle of reflection being equal to the angle of incidence. Accurate measurements were not made, however, so this is still undetermined.

The second observed phenomenon, noted by 21 observers, was the emission of radio frequency energy at 11.56 kHz, 52 kHz, 100 kHz and 20.23 MHz and 72 MHz in 20 microsecond bursts. These bursts occurred in order, starting with the lowest frequency and progressing to the highest in 800 mS steps. High signal strengths suggest that high power levels were produced at lower frequencies, but

a severe exponential falling off was noted as frequency increased. Data received by researchers at the AutologieGesellschaft Institut fur Meterological Phenomen (AGI) in Berlin indicates that the phenomenon tracked with the storm front as it moved from west to east. Comparison of log times from 21 observers is not considered conclusive, but indicates the need for further observations in a more rigorously formal manner.

Earlier Observations

Some earlier observations might have indicated such events, but the significance was not recognized until recently. For example, during World War II, British coastal radar operators and pilots regularly noted increased levels of radioemissive activity during severe storms in the English Channel.

In 1906, radio pioneer Guglielmo Marconi reported a large increase in what he termed "peculiar static" in the hours immediately prior to the great San Francisco earthquake of that year. The time difference between east and west coast somewhat obscures this report, but the signs are consistent with modern observations. It is to be noted that Marconi used wide-band Branley coherer and crystal

"In the past two or three decades, however, a different form of naturally-generated radio signals has been detected."

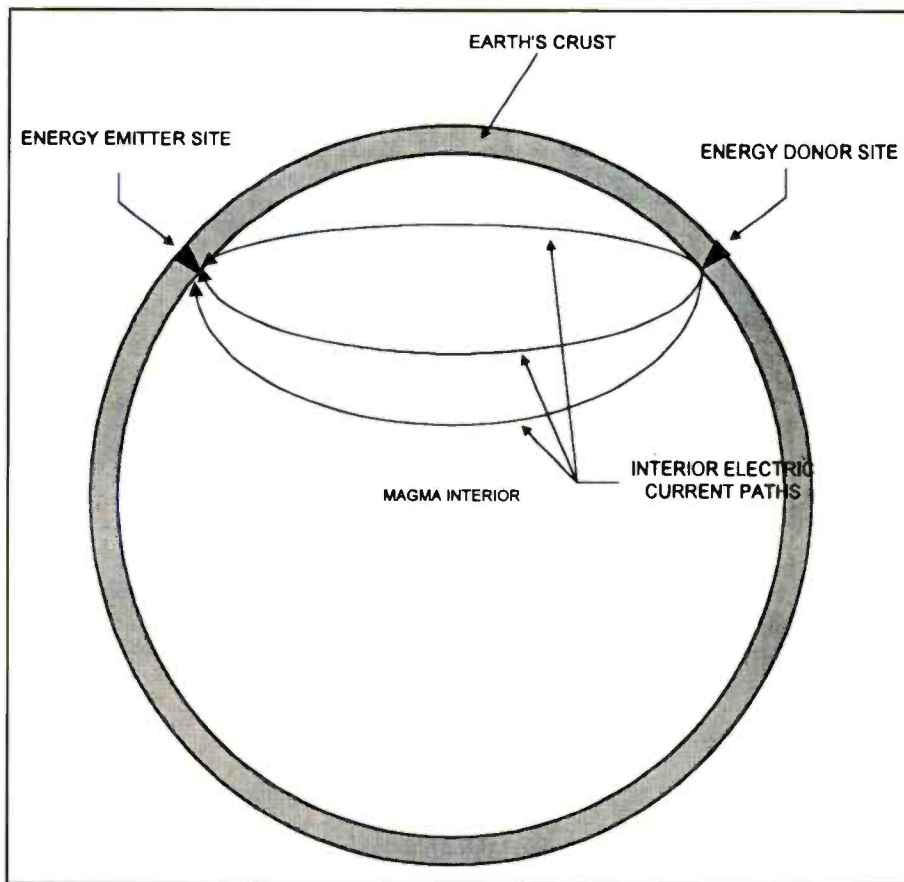

Fig. 2. Charging geocapacitors through electrical lines of force and A^2E events from a distant site.

receivers, so could not comment on the actual frequencies being detected. Because of the untuned nature of his apparatus such signals would appear as "peculiar static" to the untrained observer.

Evidence and a Theory of Operation

The mechanism of earthquakes is well known. When two continental land mass tectonic plates move against each other, mechanical stresses build up until a snapping point is reached. When the plates readjust relative to each other in order to relieve the stress, the result is felt at the surface as an earthquake.

Recently, it has been recognized that the space between the plates forms an insulating dielectric (indeed, the space is empty, except for air and gaseous vapors). Because the Earth itself is an electrical conductor, the two tectonic plates essentially form the plates of a giant capacitor (Fig. 1). This is called a geocapacitor.

Although the geocapacitance per unit area is small, the total capacitance is large because the plates may go several miles deep and stretch over hundreds of miles

in their surface aspect. If such capacitance can be charged electrically, therefore, it would store a huge amount of energy. If that energy were released, the resistance of the earth's soil would form an R-C network that would oscillate at a frequency (or frequencies) determined by the R-C time constant.

The question for scientists is, therefore: "How does the tectonic geocapacitor get charged?" Two mechanisms seem to be in effect.

First, there is a piezoelectric phenomenon occurring. Piezoelectricity is generated when certain crystalline materials are mechanically deformed. Radio channel-setting crystals are made of quartz, and work on this principle. If enough crystalline quartz-like material is present close to the tectonic interface, then a high voltage charge would be generated and stored in the geocapacitor.

Calculations indicate that a substantial portion of the geocapacitive charge occurs in this manner, but the numbers are too small to account for the energy levels seen. Piezoelectrical phenomenon could, however, be responsible for the diversity of frequencies seen much in the manner of a multi-channel radio.

"In 1906, radio pioneer Guglielmo Marconi reported a large increase in what he termed "peculiar static" in the hours immediately prior to the great San Francisco earthquake of that year."

The second phenomenon is more likely to account for the strong signal levels, hence most of the observed energy; the Autologous Absorptive Event (A^2E).

Anything that is autologous does something in reference to itself. In medicine, for example, autologous blood donors are patients who donate blood for use in their own later surgery. An autologous absorptive event is one that absorbs itself. Fig. 2 shows how Earth physicists think this phenomenon might work.

It is well known that huge electrical currents flow in the magma core underneath the earth's crust. A number of major current domains have been identified in both northern and southern hemispheres. It is also known that these lines of force come together at certain harmonic conversion points (HCP) at the surface. These sites are determined by the action of the Earth's magnetic field interacting with the solar magnetic field, and exhibit very high levels of natural energy. Mystics and shamans among primitive peoples have long used some of the more prominent of these points for religious purposes, suggesting that potential neurological or other physiological responses are possible. Evidence of this deep-seated electrical activity is shown in Figs. 3 and 4.

The plot in Fig. 3 is from a geoelectrical probe located in a laboratory at the University of Eastern California in Ridgecrest, and was recorded by Professor Lewis Helms. This instrument uses a wide baseline interferometry technique to plot the electrical currents beneath the earth's surface. It is clear to the casual observer that a major disruption is occurring at a deep level. This plot was taken between -10 to -2 hours relative to the Northridge quake.

Confirming the evidence of Fig. 3 is the geosonograph plot shown in Fig. 4. This instrument is something like a radar, boaters' depth sounder, or medical ultrasound unit in that it pans back and forth looking for backscattered energy. The incident pulse generated by the geosono-

Six Steps For Building The Perfect Monitoring Station

Price Includes:
DB-32, CC-30 And
Spectrum CD Rom

1.

\$449



The Scout®

Optoelectronics pioneered the frequency recorder with its introduction of the Scout. The Scout is ideal for any serious monitoring station. After a day of capturing frequencies in the field, you can download the Scout's 400 frequencies into your PC* and create scanning band plans, or match up recorded data with the Spectrum FCC database (Optional)

- 10MHz - 1.4GHz frequency range
- 10 Digit LCD Display with EL backlight and 16 segment signal strength bargraph
- Beeper and vibrator mode to alert you when a frequency has been logged.
- Reaction Tune AOR AR8000/2700 ICOM R10, R7000, R7100, R8500, R9000, and Radio Shack Pro 2005/6 (w/ 05456 / Lite installed) and Radio Shack Pro 2035/42 (w/ 05535 installed)

*Download recorded data to PC using optional OptoLinx interface

What they're saying about the new Xplorer

"We weren't disappointed. Within a second, the Xplorer latched onto near-field signals".....Bob Grove, Monitoring Times Magazine

"I just tell them that it's a radio James Bond would be proud to use".....Ed Griffin, Popular Communications Magazine

"I was able to replace three test instruments and carry just the Xplorer".....Luis Libin, Director of Technology, NBC Network

2.

\$899



The Xplorer

For the ultimate in Nearfield detection the Optoelectronics Xplorer stands alone. If you are looking for an all in one hand-held Receiver, Decoder and Frequency Recorder, look no further than the Optoelectronics Xplorer. Fitted with the maximum sensitivity available in a Near-field device, the Xplorer takes monitoring to a new level.

Whether it's two way communication testing, security/surveillance applications, or just plain fun, the Xplorer is ideal. Packed with a 500 frequency memory, all data is stored with time and date. See it, Hear it, Decode it, Map it. The Xplorer locks onto any frequency from 30MHz-2GHz in less than 1 second, displays the frequency, numerical deviation, or signal strength, demodulates the audio, and will decode any CTCSS, DCS, or DTMF data.

Let the Xplorer soar you to new heights.

- 30MHz-2GHz in less than 1 second
- Two line LCD display. First line displays frequency, second line switches between CTCSS, DCS, DTMF, Deviation or Signal Strength
- GPS interface (NMEA-0183 GPS required)
- Auto Hold, 1000 Lockouts, Skip, Auto or Manual Store
- Real-Time Clock/Calendar with battery back-up
- Rotary Encoder for easy selection of menus for setup
- Internal Speaker, Audio earphone/headphone jack
- Built-in PC interface with interface cable and download software included
- Includes Built-in Rapid Charge NiCad batteries and Rapid Charger

3.

\$129

The OptoLinx



The OptoLinx is all you need-Whether it's computer control of your AOR AR8000, ICOM CI-V receivers, or downloading Scout data to your PC. The versatility of the OptoLinx also allows for datalogging of frequencies with the Optoelectronics M1, or datalogging CTCSS tones and DCS codes with the Optoelectronics DC440.

- Use with any ICOM CI-V receiver for computer control
- Download recorded Scout frequencies into your PC
- Computer control for the AOR AR8000 scanner
- Easy Flat Flexible cable connection for the AR8000
- Data Slicer Circuit-converts FSK to RS232. Works with popular decoding PC software for ACARS, POCSAG, Etc.
- Includes Radio Manager for Windows computer control software, POCSAG decoding software, and download utility software.

NEW

The OS456LITE Computer Control Scanning Modification

Remember the days of staring at your scanner while monitoring the local police, sitting around looking at the same old display? That's all changed! Drop in the OS456LITE and take your Radio Shack Pro2005/6 to new heights with the OS456LITE. Now you can scan remarkably faster and import DBase files from the Spectrum FCC database, all with the ease of PC control. The OS456LITE continues in the tradition of the original OptoScan 456 with all the same functions, but without the CTCSS, DCS, and DTMF decoding features. Every good monitoring post should be equipped with a good receiver. The OS456LITE installed in your Pro 2005/6 is the scanner / computer enthusiast's dream.

More Great OptoScan Products:

- OS456 (Decoding included for the Pro 2005/6)..... \$199.
- OS535 (Decoding included for the Pro 2035 /2042)..... \$199.



The DC440

No receiver or monitoring station is complete without a DC440 Decoder. See what you are missing when you connect the DC440 with any scanner or receiver and instantly decode all the standard CTCSS, DCS, and DTMF data. Connect the DC440 to your OptoLinX and PC for datalogging all tones and codes with time and date stamp. The DC440's easy operation contains six modes; All Mode Decode, CTCSS Decode, CTCSS Period, DCS Decode, DTMF Decode, and DTMF Recall. Automatically decode 50 CTCSS tones, 106 DCS codes, along with 106 DTMF characters. The serial interface on the DC440 conforms to the CI-V interface standard, allowing it to be connected to a PC for remote control with the optional OptoLinX



6. Contact Opto Direct



Looking for a good hand-held frequency counter? Optoelectronics Handi Counter®, a name you can trust in frequency measurement



- 10Hz-3GHz Frequency Range
- Measures Period, Ratio, and Time Interval
- 10 Digit LCD w/ EL Backlight
- 16 Segment Signal Bangraph
- Built-in 800MHz High Pass Filter
- Built-in RS232 PC Interface
- Patented Digital Auto Filter / Capture



- 10Hz-2.8GHz Frequency Range
- 10 Digit LCD Display w/ LED Backlight
- 16 Segment Bangraph
- TTL Output for PC Interfacing
- Patented Digital Auto Filter / Capture



- 1MHz-2.8GHz Frequency Range
- 9 Digit LCD Display
- Auto Hold Last Frequency Displayed
- Patented Digital Auto Filter / Capture

FACTORY DIRECT ORDER LINE 800-327-5912

OPTOELECTRONICS®

INNOVATIVE PRODUCTS FOR A MODERN PLANET

CIRCLE 150 ON READER SERVICE CARD

5821 NE 14th Avenue • Ft Lauderdale, FL • 33334
Telephone (954)•771•2050 Fax (954)•771•2052

Visa • MasterCard • C.O.D. • Prices and Specifications are subject to change without notice or obligation

Email: opto@igc.net Internet: www.optoelectronics.com

SE SIGNAL ENGINEERING'S
High Performance CB & 10 Meter Antennas

SUPERHAWK

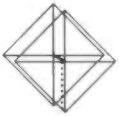

WHITE LIGHTNING
THE Four Element
Antenna

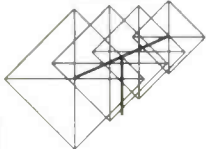

LIGHTNING 6

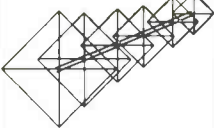

Goldenrod
45 Spyder A+
Broadband Hi
powered MOBILE

THUNDER 8
Hi Gain
Bi-Directional
OMNI
Electronically
Steerable

And, also,
NEW QUAD
LIGHTNING 8
THE most
POWERFUL
CB base in the
world today!

ALL SE PATENTED rotary beams are true quads and OUTPERFORM their counterparts (quad/yagi types). SE's patented SFS matching system makes SE QUADS the most technologically advanced antennas in the world today.

If your dealer doesn't have SIGNAL ENGINEERING, write or call for full specs. DEALER Inquiries invited.

MasterCard, VISA, AMEX, Discover

SIGNAL ENGINEERING

155 San Lazaro Ave, Sunnyvale, CA 94086
 (408) 733-1580

WORLDS SMALLEST
TRANSMITTERS

XWB1000E-Z kit \$46.95

MICRO FM TRANSMITTER

Voice transmitter kit. Transmits 88 to 108MHz. Range up to 1/2 mile. Includes mic and battery. Uses surface mount components



XTL1000E-Z kit \$69.95

CRYSTAL CONTROLLED TRANSMITTER

Voice transmitter kit. Range up to 1/2 mile. Super sensitive mic. Transmits at 143.790MHz. Uses surface mount components



XTL3000E-Z kit \$99.95

LONG RANGE CRYSTAL CONTROLLED TRANSMITTER

Voice transmitter kit. Range up to 1 mile. Super sensitive mic. Transmits at 143.790MHz. Uses surface mount components



XLC900(C) \$49.95

SCANNER CONVERTER KIT

Uninterrupted coverage of the 800 to 950MHz band. Works with any 400 to 550MHz scanner.



XBD500E-Z KIT \$129.95

BUG DETECTOR

Professional quality. Covers 1MHz to 2GHz. Uses new microwave integrated circuit amplifier. Adjustable sensitivity. Earphone jack for quiet operation.



ASK ABOUT OUR CRYSTAL CONTROLLED TRACKING TRANSMITTER XTR300(E-Z) \$79.95

ORDER LINE
 1-800-336-7389

Call for FREE Catalog

CHECK VISA, MC, MO, or COD, S&H EXTRA



YANDI ELECTRONICS, INC.
 1270 E. BROADWAY RD. # 113
 TEMPE, AZ 85282

SATISFACTION GUARANTEED
 SERVING THE PUBLIC SINCE 1981

CIRCLE 90 ON READER SERVICE CARD

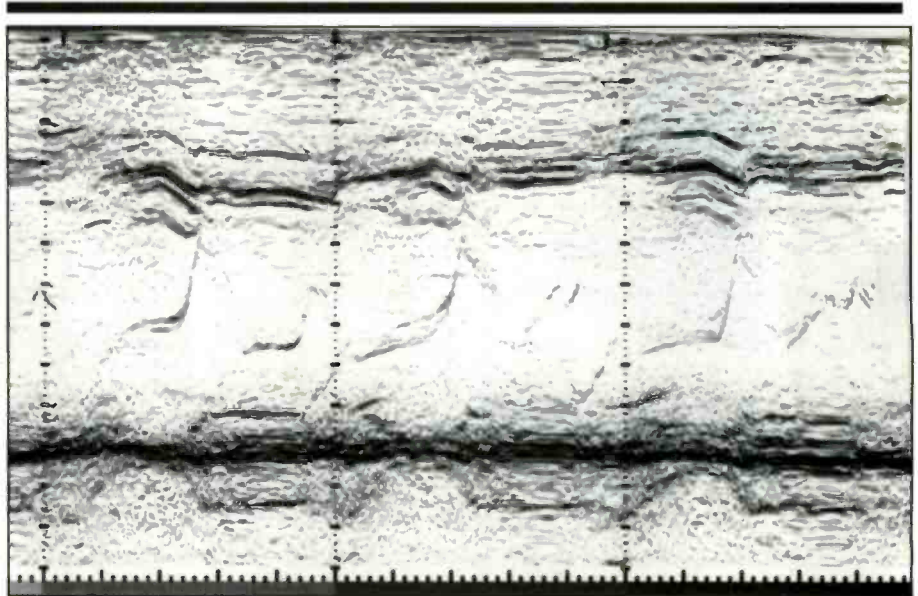

Fig. 3. Geoelectric probe plot of Northridge earthquake.

graph is a high voltage electrical potential. If no electrical (as opposed to physical) anomalies are noted, then the trace would be relatively clean, except for noise created by small artifacts. In Fig. 4, however, we note severe electrical perturbation at about the same depth as predicted by the geoelectrical probe, but occurring at a time 800 ms later. The significance of this relationship is not understood by physicists.

The electrical energy stored in the geocapacitor, as well as the electrical energy

in the convergent fields under the surface, must come from someplace. The Law of Conservation of Energy requires it: energy is a zero-sum game. That is, energy "created" at some point must be subtracted from energy existing at another

"It is well known that huge electrical currents flow in the magma core underneath the earth's crust."



Fig. 4 Geosonograph of subterranean activity prior to Northridge earthquake.



75-510

14 channel UHF FM FRS (Family Radio Service) transceiver.

- High quality UHF FM transmit and receive audio for clear, crisp and interference-free communication
- User selectable privacy codes for 38 separate lockouts per channel
- 14 computer controlled frequency selections
- Built-in modulation circuit adjusts to a wide variety of voice levels
- Supplied with rechargeable batteries and a charger
- Large, backlit LCD readout
- Maximum power for up to 2 miles range
- Automatic squelch eliminates noise between transmissions
- Keyboard lock prevents accidental activation of other function keys
- Quick up/down channel selector pads
- Scan mode to search for busy channels
- Busy channel delete to bypass unwanted conversations
- Automatic time-out timer turns off transmitter
- Automatic power save mode conserves power for longer battery life
- Memory retention
- Jack for earphone or speaker/mic (both sold separately)
- Ultra-compact, lightweight and built to take it

Great for business and family uses, hunting, fishing, camping. No license required.

SIRIO

Serious CB Antennas

TORNADO 27

5/8 wave antenna for base station made of anti-corrosive aluminium tubes and supplied with jointing sleeves of polythene to guarantee a perfect waterproofing. Strong and easy to install.

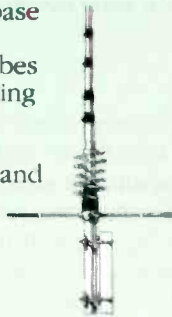

HP3000

7/8 wave vehicular antenna, base loaded, specially designed for hi-power, from 1500 Watts continuous to 3000 watts (P. e. P.). The coil is made of big section copper wire and works as an impedance transformer and the conic whip is made of 17/7 PH stainless steel to get the best performance. The UHF-PL259 connection makes it particularly suitable for the installation on a magnetic mount. The HP3000 is easily tilted and locked into position without the use of screws.



NEW PROFESSIONAL Microphones from LOWE

LEP300



Extremely comfortable communications earpiece.

LEP 400 series



Earpiece with covert microphone and PTT switch.

LEP 500 series



Earpiece with light-weight boom microphone attached.

LEP 600 series



Single headband supported earpiece with boom mic and PTT

MIDLAND

CONSUMER RADIO

75-800

The Next Generation Portable CB Transceiver

This ultra-compact, lightweight portable features 40 channels, 7 watts receive, large LCD, and more. Includes low-profile flex antenna, 12V DC power cord w/lighter socket plug and carry strap.



75-805

Compact 3-in-1 Portable Transceiver

The world's only 7 watt receive, 40 channel Walkie Talkie w/ 7 ch. weather alert and 88-108MHz commercial FM radio built in. New slim cellular like size and design.



75-810

The Midland Communications Center

Up-to-the minute, vital weather info & 40-channel CB communication all in one handheld. 7 watt receiving 40 ch. CB does it all. Built in 10 channel WX receives all 7 U.S. NOAA & 3 Canadian stations.



75-784

ProSport XL

Outperforms low-power GMRS radios and offers four times more channels. 7W receive, full 40 channel operation. Features high/low power switch & "Power Save" mode.



75-820

Mini 40 channel Portable CB

10 channel WX/hazard monitor. Dual watch permits monitoring two channels. Hi/Lo power settings. Jacks for remote microphone and external speaker (not incl.).



Electronic Distributors
325 Mill St.
Vienna, VA. 22180

Ph: 703.938.8105
FAX: 703.938.4525
www.elecdist.com

For more info
see your
favorite dealer.

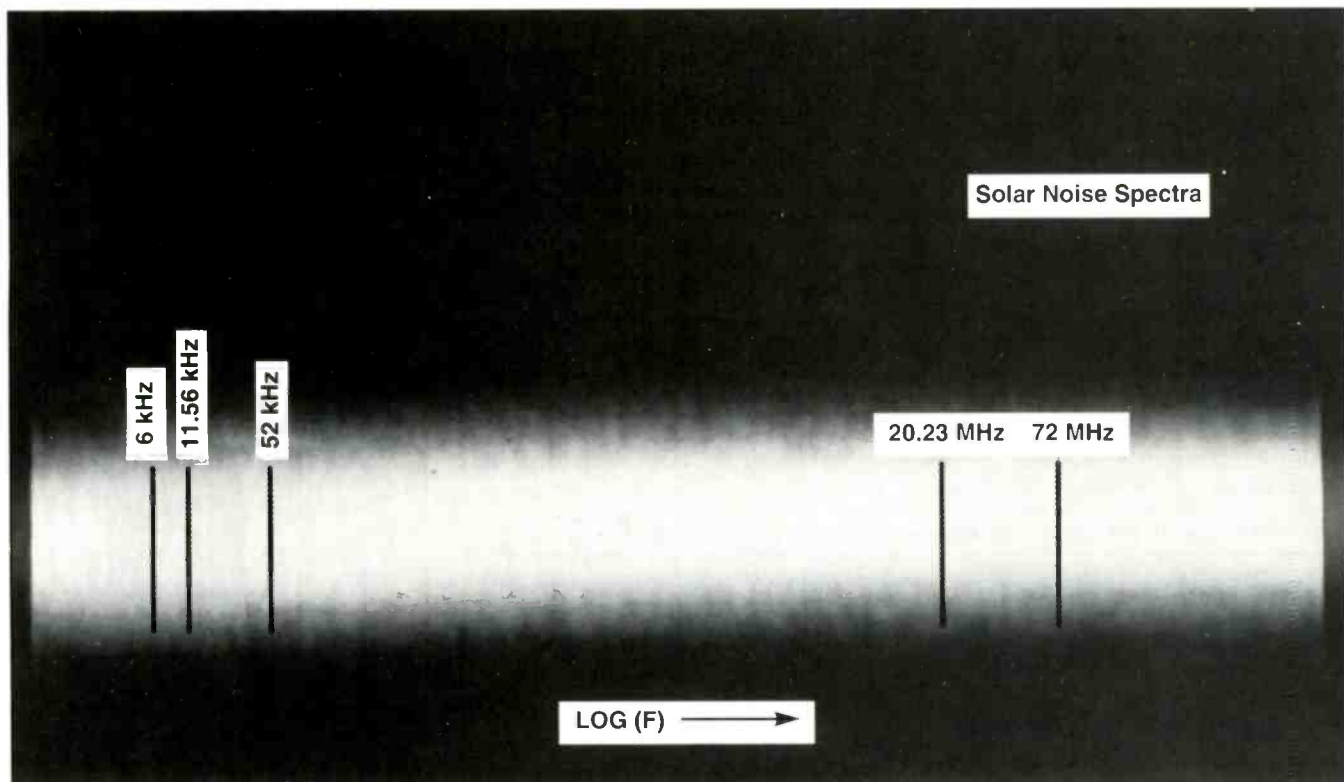

Fig. 5. Spectrum analyzer plot showing suck-outs in Europe. Some main signal sources include solar noise spectra, terrestrial noise as well as man-made signals.

point. In the A²E phenomenon, it is believed that electrical energy is sucked out of the atmosphere at a donor site (see Fig. 2), transmitted through the electrical field lines under the Earth's surface, to be stored in the geocapacitor. This phenomenon starts less than 24 hours prior to the onset of the earthquake, and continues until about 6 hours after the major shocks are completed.

The Northridge quake occurred, luckily enough, at a time when some atmospheric noise studies were being conduct-

ed in southern Europe by the AGI-Berlin. Radio frequency spectrum analyzers were used to study the noise emission background, mostly from solar sources, appearing in Earth's atmosphere (Fig. 5), and noted sudden decreases in signal strength at certain frequencies that were later correlated with the Northridge emissions. This "suck-out" effect may also explain why radio signals sometimes suddenly drop in amplitude. The energy source—atmospheric RF—can consist of either man-made or natural signals; the

A²E event doesn't care which is the case.

One theory as to why such A²E phenomena are seen in tornado and microburst thunderstorms is the possibility of the electrical discharges of lightning interfering with the internal Earth currents. The disruptions cause sudden and immediate "suck-outs" at distant donor points, resulting in magnification of the storm's energy levels close to the emitter point.

Conclusion

The initial observations reported in this article would probably have not been seen as significant because they were from different sources. Fortunately, a confluence of several events (resulting in Figs. 3 through 5), all made of the same disaster, fell into the hands of researchers at AGI-Berlin. They were able to correlate the data and suggest an explanation for them. The significance of this work is at best undetermined, but may well be seen by the cover date of this publication. ■

References

1. Joseph J. Carr, "Be a RadioScience Observer—Part I," *Shortwave* magazine, November 1994.
2. Joseph J. Carr, "Be a RadioScience Observer—Part II," *Shortwave* magazine, December 1994.
3. Joseph J. Carr, "Be a RadioScience Observer—Part III," *Shortwave* magazine, January 1995.

SEE US ON THE WEB!
www.vikingint.com

Rave Review
Pop Comm
April '96

Professional 10 HOUR RECORDER

"BUILT LIKE A BATTLESHIP"

- Heavy duty commercial recorder - NOT improvised from consumer models
- 12, 14, and 16 hour models also available
- BUILT-IN voice activation (add \$30)
- Applications information included
- Dimensions: 11.5 x 7.0 x 2.75"

SPECIAL Pop Comm Price

\$159

Includes UPS to 48 States

FREE 48-PAGE SPECIAL EQUIPMENT CATALOG

COD's OK. Calif. residents add tax. Sorry, no credit cards. Free catalog USA only; other countries \$5.

Viking International 150 Executive Park Blvd. #4600 San Francisco, CA 94134
Factory Direct Phone: (415) 468-2066 • Fax: (415) 468-2067 "Since 1971"

Radio's Overlooked Genius

You Probably Never Heard of Murgas, Yet He Was More of a Wireless Pioneer Than Marconi . . .

By Alice Brannigan

Look up [radio] in history books and you will read about Fessenden, Marconi, DeForest, Armstrong, and possibly even Stubblefield. There's little likelihood you will come upon the name *Murgas* among those who have received credit for their efforts and inventions in radio.

Fact is, a century ago, there were other experimenters whose efforts were no less impressive than those whose names became well known. Rev. Joseph Murgas, for example, attracted the attention of the communications world to Wilkes-Barre, PA. For nearly 35 years (until his death in 1929), Murgas served as pastor of Sacred Heart Slovak Church.

A Man of Many Parts

Born February 17, 1864, in Tajov (Jabrivka), Zvolen County, Slovakia, Joseph Murgas entered the Bratislava seminary at age 18 in order to study for the priesthood. In 1884 he transferred to the Seminary at Ostrihom where, in addition to his theological studies, he could begin his first electrical and wireless experiments. All this, with simultaneously studying French, German, astronomy, and advanced physics. In addition, Murgas was also enrolled at Munich's celebrated Academy of Fine Arts.

Murgas was ordained in 1888, however he continued with his art studies until he later graduated as an accomplished painter with honors and awards. His electrical and wireless experiments progressed too, and he enrolled at the Electrical College of Vienna Austria as an advanced student.

All this, to say nothing of Murgas' pointed political opinions. He was an ardent patriot, and was an authority on the lives of the Slovak heroes who had fought for freedom from Hungary for almost 1,000 years. This topic was the focus of many of his most dramatic paintings.

Because Murgas was so widely recog-

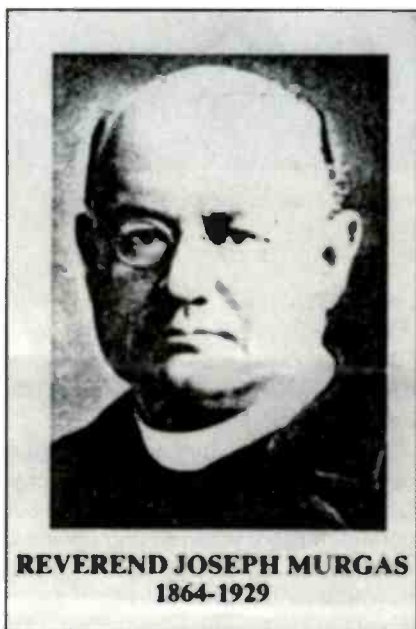

REVEREND JOSEPH MURGAS
1864-1929

Rev. Joseph Murgas (1864-1929).

nized as an authority in the arts, the Hungarian government asked him to evaluate a contemporary painting to be hung in the Hungarian Parliament. It depicted the occupation of ancient Slovakia by the Magyars in the year 907. Unbeknownst to the Hungarians, this was a very sore point with the highly nationalistic Murgas. He felt that the painting did not depict the event honestly, and he promptly denounced it as a "tragic representation," further insulting it as unworthy of art.

This wasn't what the Hungarian government wished to hear. Murgas was charged with disloyalty and having proven himself as holding anti-government tendencies. Under Hungarian law, he was obligated to leave the country. He thereupon departed for the United States, arriving in April of 1896.

Soon after, Murgas was assigned to a newly constructed church in Wilkes-Barre, Pennsylvania. He became a dynamic power on expanding the influ-

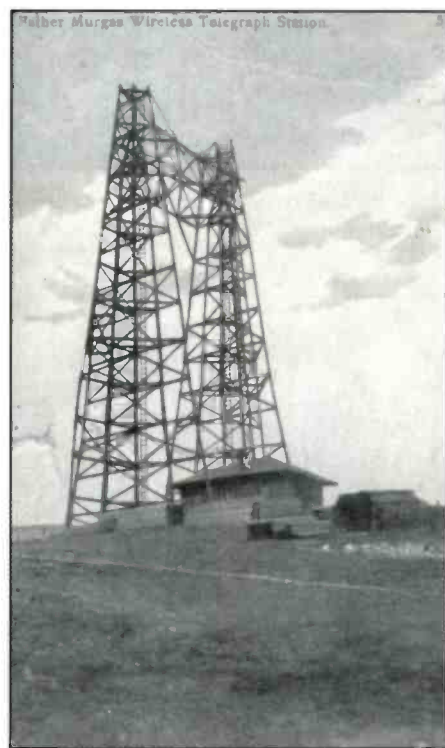

The Murgas telegraph towers prior to their completion.

ence and services of his church. He also established several Slovak-American organizations, and still found time for collecting butterflies and moths, botany, and his experiments with wireless.

Murgas & Wireless

Murgas built a small lab in his parish house during 1898. That's where he developed a system of communications based upon two high-frequency tones

"Fact is, a century ago, there were other experimenters whose efforts were no less impressive than those whose names became well known."

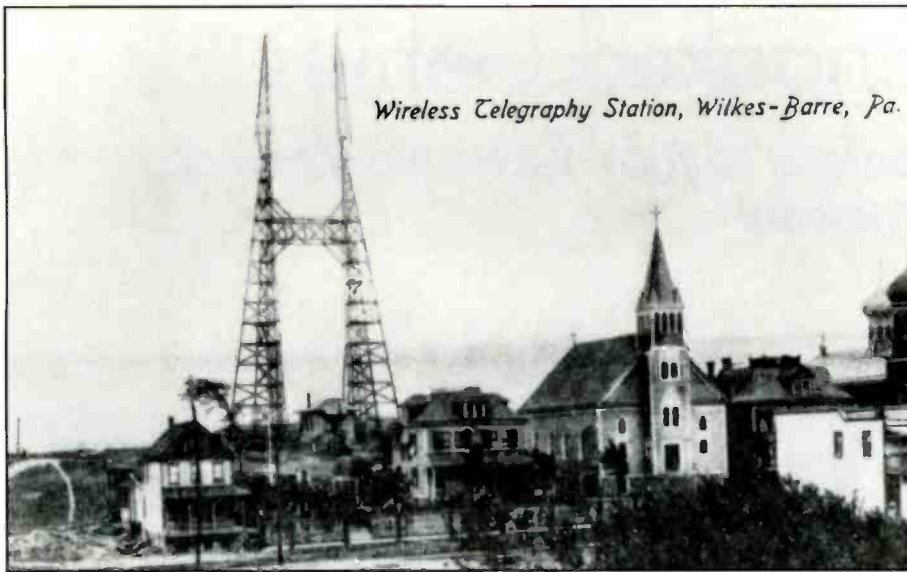

Wireless Telegraphy Station, Wilkes-Barre, Pa.

When the towers were completed, extension sections had been added to the tops to add to their height.

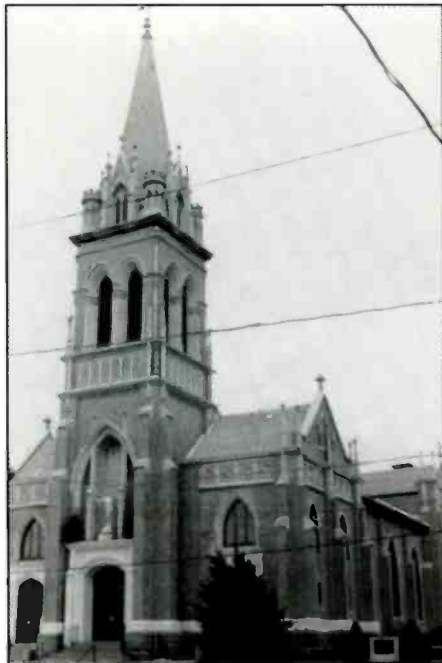

*The Sacred Heart Church, Wilkes-Barre.
(Photo by Ed Shedlock.)*

(each of a different pitch), one tone representing (and in common with) the Morse code "dot" and the other with "dash." This allowed faster transmission speeds than the Marconi system.

Murgas sent out his signals via rotary spark with the signals fed into a single pole antenna. It had a distributing arm at the top from which wires extended.

In 1904, Murgas was awarded U.S. Patent #759,825 for his "Wireless Telegraphy Apparatus," and #759,826 for his "Method of Communicating Intelli-

gence by Wireless." These patents were sold to the Universal Aether Company of Philadelphia, a group of international financiers who wanted to Market the Murgas invention.

Eventually, the Murgas Tone System was covered by no less than 17 patents. Universal Aether spent some \$25,000 erecting 200-foot transmission towers in North Wilkes-Barre and ones 19 miles away in Scranton. Nothing like the towers had ever before been constructed.

The towers were first tried out on April 27, 1905, with U.S. Navy and prominent local representatives present. The first official test and public demonstration was on November 23, 1905, receiving national media coverage and attracting members of the government, scientific community, as well as area residents.

The results were stunning, proving that wireless was practical at long distances over land. Also, they demonstrated Murgas' superior telegraphic method which ran at 50 wpm, compared to Marconi's, which operated at 15 wpm.

Lt. Cdr. Samuel S. Robinson, USN, witnessed the demonstration and categorized them "most satisfactory." He wrote that Murgas had the best system of wireless transmission—one which threatened to revolutionize world communications.

Problems

All this would have been great, except that the government had already signed contracts with Marconi and purchased millions of dollars of Marconi equipment. Many other governments had done like-

"In 1904, Murgas was awarded U.S. Patent #759,825 for his 'Wireless Telegraphy Apparatus,' and #759,826 for his 'Method of Communicating Intelligence by Wireless.'"

wise. Adoption of the Murgas system would have caused a lot of government funds spent on Marconi equipment to be considered "wasted." Would Universal Aether's international financiers allow this to take place? Universal's forces felt they could do battle with those forces only if they could match their wealth. That was a major obstacle, and it loomed over marketing the system.

By 1907, Murgas had been able to send speech over his station by the modification of his system. These experiments were witnessed by a number of people. Unfortunately, Universal Aether did not have the resources to finance any extensions in speech transmission. In fact, the company had become quite disillusioned by the domination of Marconi's enterprises in the field of wireless.

The Hand of Fate

Fate also participated in the matters at hand. The Scranton station was destroyed by a storm. Even worse, two of Universal Aether's most important backers suddenly died. The combination of these three unfortunate factors resulted in Universal Aether's abandonment of Murgas. Murgas continued his efforts, but on a reduced scale.

Marconi and Fessenden, of course, knew of the Murgas system. Marconi had once even visited Wilkes-Barre to see it in operation. Subsequently, Marconi came up with a version of Murgas methods, which he dubbed the "Sonorous System." Fessenden's own variation was called "The Tuned System."

Eventually both Marconi and Fessenden entered the commercial market with their own respective versions of the tone system that Murgas had developed earlier. What followed was a complex chain of lawsuits between Marconi and Fessenden over which of the two of them had actually invented the tone method based upon high-spark frequency. The usual scenario was for Fessenden to sue Marconi and the cases bounced back and forth for a number of years.

Finally the U.S. District Court (South-

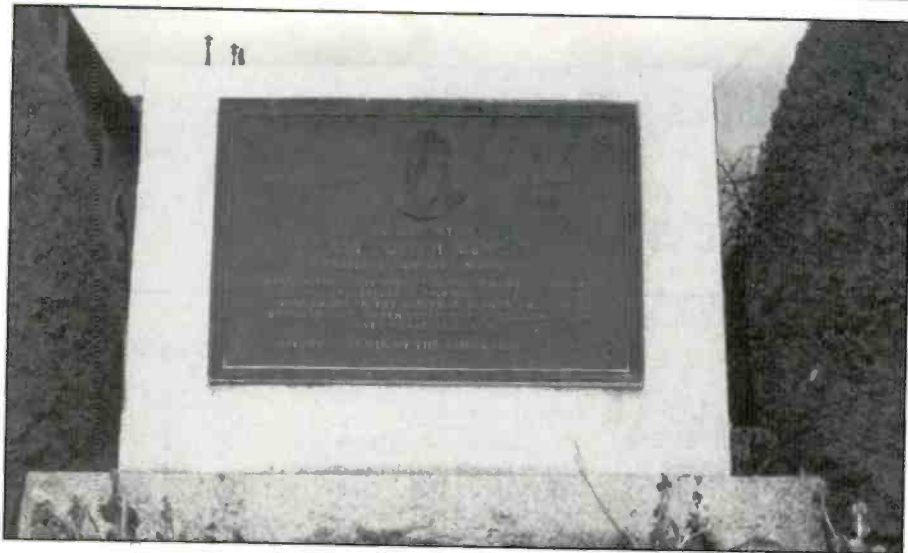

In front of The Sacred Heart Church is a bronze plaque dedicated to Murgas, specifically mentioning his pioneering wireless discoveries. (Photo by Ed Shedlock.)

“Eventually both Marconi and Fessenden entered the commercial market with their own respective versions of the tone system that Murgas had developed earlier.”

A plaque and monument (including a miniature reproduction of the station) stands near the original site of the towers in Wilkes-Barre. King’s College, in Wilkes-Barre maintains a considerable amount of Father Murgas memorabilia and offers the Reverend Joseph Murgas Program in Communications Studies.

Although he never achieved worldly fame, certainly Father Joseph Murgas rightfully deserves a place within the inner circle of wireless pioneers we cherish.

As always, we invite readers to submit old time radio and wireless picture postcards, station photos, QSLs, stories, station lists, memories, questions and suggestions for use here. Next month, let’s meet again on the road to Radioville. ■

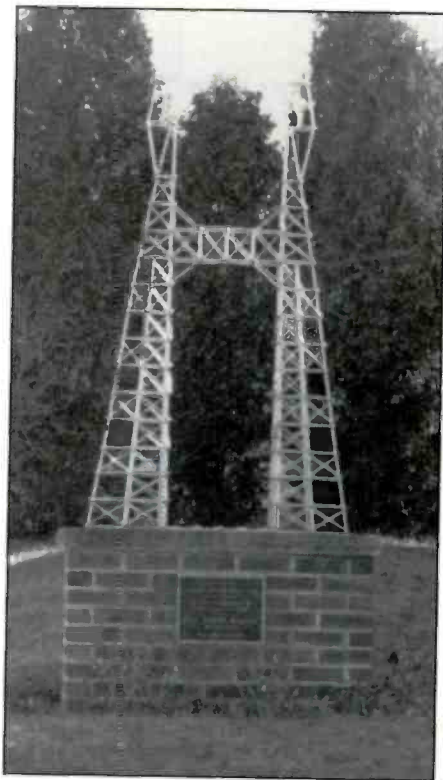

This scale model of Murgas towers has been erected near the site of Murgas original station in Wilkes-Barre. (Photo by Ed Shedlock.)

pendent Slovak Republic named its only broadcasting station after him and also issued two stamps in his honor. The stamps depicted the Wilkes-Barre transmission towers. During WWII, an American Liberty ship was named after him.

When it comes to effective multi-band DX antennas for limited space applications, it comes to the world class **ALPHA DELTA DX-SWL** family of High Performance SLOPERS!

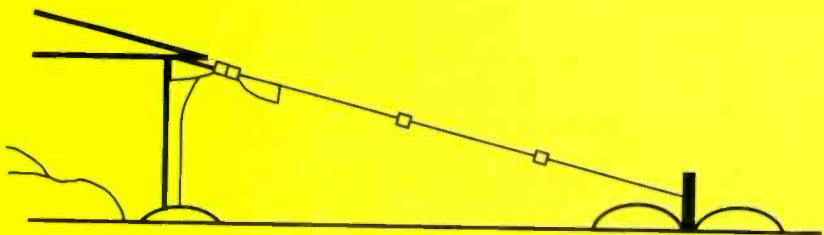

- Fully assembled, ready to use and built for long life. So strong, it can even be used to transmit—up to 2 kW!
- Superior multi-band performance on 13, 16, 19, 21, 25, 31, 41, 49, 60, 90, 120 meters plus the AM broadcast band (.5-1.6 MHz). All in a single compact antenna. Alpha Delta first!
- Efficient multi-band frequency selection by means of special RF choke-resonators—instead of lossy, narrow band traps.
- Overall length just 60 feet. Requires only a single elevated support—easier to install than a dipole.
- 50 ohm feedpoint at apex of antenna for maximum DX reception. A UHF connector is provided on the mounting bracket for easy connection to your coax.
- A top overall rating in Radio Database International’s hard-hitting White Paper, “RDI Evaluates the Popular Outdoor An-tennas.”

- Model DX-SWL, AM broadcast thru 13 mtrs, 60’ long \$79.95
- Model DX-SWL-S, as above but 90 thru 13 mtrs, only 40’ long \$69.95

Both models are broadbanded and give excellent performance across the utility frequencies.

Available from your local Alpha Dealer or direct. Add \$5.00 shipping and handling (U.S.A. only) Exports quoted.

ALPHA DELTA COMMUNICATIONS, INC.

P.O. Box 620, Manchester, KY 40962

Phone: (606) 598-2029 • FAX: (606) 598-4413



ern District of New York) ruled that neither one had invented it. Murgas was declared the originator of the invention that had been claimed by both Marconi and Fessenden.

President Calvin Coolidge appointed Murgas as a member of the Federal Radio Commission. Father Murgas died on May 11, 1929. Recognition? In 1939, on the 10th anniversary of his death, the inde-

The Radio Connection

A LOOK BEHIND THE DIALS

Our Emerson Radio is Almost Finished!

Reader Don Borowski comments on our February mail concerning vintage radio and baseball: "I think that short of being at the ballpark, radio is the only way to enjoy the game. I have listened to recordings of ballgames long past, and I have watched any number of old movies depicting ballgames being broadcast over the radio. The major league broadcasts today still follow the same tradition of those bygone days. I enjoy tuning into a game on one of my vintage radios, adjusting it for the proper euphonic audio enhancement, and then sitting back in my easy chair, ready for my journey back in time some 50 or 60 years. (Which was before I was even born!) There must be a synergy between the still traditional game and radios made during the heyday of baseball. Somehow, the tubes must sense it, and do their best." Via e-mail <borowski@spk.hp.com>.

Thanks for your comments, Don. You make a good point. The real enjoyment of this hobby goes beyond that of collecting and restoring those old sets—nothing else even comes close to listening to one!

Do you have a favorite radio? Share it with us; your comments and photos are most welcome.

Radio of the Month

This month's radio is the 1942 Zenith "Kenwood" console model 12H689. This is a rather interesting set. It covers Armstrong's early FM broadcast band between 42 and 50 MHz. In 1945 the FCC announced the new FM band allocations, heralding the end of Edwin Armstrong's Yankee Network. It is a large 12-tube chassis, and even sports an "S" meter for tuning strength and FM center tuning. The tuning dial scales are in a "shutter dial arrangement;" the AM and FM band dials are made in half-clamshell sections that swing into place as the bands are changed. The main dial is the SW band in a blue background, the AM BCB band shutter dial is gold, and the FM band shutter dial is black and is marked with the old FM band channel numbers.

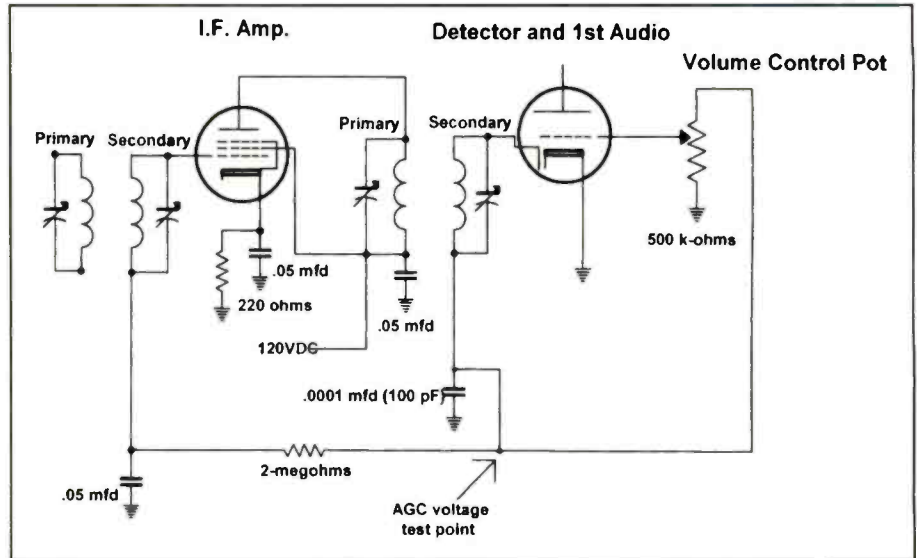

Figure 1. A view of the test point where you may monitor the ACG voltage.

There is a center slideout drawer with a 78 RPM record changer. Some radio collectors will avoid a set that is a combination radio and phonograph.

Shutter dials are very collectable. Restored, this radio could go for as much as \$400 depending on the condition of the radio and the local radio market. I've seen this model recently offered on an Internet usegroup for \$695—a bit high, I feel. Its finish and speaker grill cloth are original and in good condition, adding to the value. I paid \$250 for it—as is—in 1992 from a radio dealer. Do you remember the TV series, "The Waltons?" That Zenith tombstone in the family's living room was a shutterdial. Several versions of that radio were made, and have commanded prices as high as \$3000! Collectors refer to those tombstones the "Walton radio."

The year 1942 just about marked the end of the handsomely-styled upright console era. Zenith sets are good "lookers," but I find the large chassis Philco or RCA sets offer better SW performance.

Cleaning Variable Capacitors

We have been covering some of the fundamentals of restoration electronics,



Photo A. This vintage 1942 Zenith "Kenwood" features a shutterdial and pull-out center phonograph.

using a small five-tube Emerson kitchen radio as our learning guinea pig. Let's continue our restoration project.

A problem with old sets is the dust that gathers between the rotor (the plates on

"There must be a synergy between the still traditional game and radios made during the heyday of baseball."

the shaft that turn) and stator (the plates that are fixed positioned) plates of the tuning capacitor. With kitchen radios, the dust problem is often compounded by many years of exposure to cooking greases, making the dust rather sticky and hard to remove.

The dust should be removed. Left between the plates, it may cause the tuning to sound scratchy or erratic. If only dust is present, a gentle stream of high-pressure air will often suffice. Be careful! Don't bend or distort the capacitor plates! If the dust is mired in grease, you will need to use a spray solvent to flush out the capacitor. One caveat. Before using any chemicals, remove the radio's dial scale! You may otherwise end up removing far more than you bargained for. A small plastic sandwich baggie over the speaker will protect the paper cone. Also, try to work outdoors or in a well ventilated area, and wear eye protection. I use a general purpose electrical solvent for this purpose. Those spray can degreasers using alcohol as the solvent are ideal. Take great care not to bend or damage the capacitor plates! I usually place a number of tissues around the capacitor assembly to absorb excess solvent. This job can be a tad messy.

While washing the capacitor plates, also clean out any traces of old grease in the capacitor bearings that are located behind the main tuning shaft in a recess milled into the capacitor metal frame. Replace the grease, while being careful not to get any on the capacitor plates. Excess grease should be removed.

On the top of the main tuning capacitor you usually will find two compression mica capacitors—one each built into the stator plate assembly for the local oscillator and the tuned RF stage. If these are dirty, they too should be cleaned with an electrical cleaner. Note that the following steps will require a total alignment of the receiver. Back out the alignment screws on the mica trimmers. Carefully spray the solvent into the compression mica trimmer assemblies to flush out any dirt or dust. Allow the solvent to completely evaporate before resetting these adjustments.

If the IF transformers also use compression mica trimmers for alignment,

We Have Scanners with 800MHz Coverage!

ICOM R9000, R8500, R1, R10, R100

Yupiteru MVT-7100, MVT-8000

AOR AR-2700, AR-8000, AR-5000, AR-3000A, Scout hookup's

WinRadio for PC-500Khz-1300Mhz continuous coverage

AR-8000 Wide Range Receiver

500KHz~1900MHz coverage AM/NFM/WFM/USB/LSB/CW

1000 Memory Channels (50 x 20) • Computer Interface

Ferrite Rod Antenna for below 2MHz • Selectable Step Size

ATLANTIC HAM RADIO Ltd.

(416) 636-3636

(416) 631-0747 fax

<http://www.interlog.com/~ahr>

368 Wilson Ave

Downsview, ON

Canada M3H 1S9



All U.S. Orders Shipped Air



World's Most Powerful CB and Amateur Mobile Antenna*

Lockheed Corp. Test Shows
Wilson 1000 CB Antenna Has
58% More Gain Than The
K40 Antenna (on channel 40).

In tests conducted by Lockheed Corporation, one of the world's largest Aerospace Companies, at their Rye Canyon Laboratory and Antenna Test Range, the Wilson 1000 was found to have 58% more power gain than the K40 Electronics Company, K40 CB Antenna. This means that the Wilson 1000 gives you 58% more gain on both transmit and receive. Now you can instantly increase your operating range by using a Wilson 1000.

Guaranteed To Transmit and Receive
Farther Than Any Other Mobile
CB Antenna or Your Money Back**
New Design

The Wilson 1000 higher gain performance is a result of new design developments that bring you the most powerful CB base loaded antenna available.

Why Wilson 1000 Performs Better

Many CB antennas lose more than 50% of the power put into them. The power is wasted as heat loss in the plastic inside the coil form and not radiated as radio waves.

We have designed a new coil form which suspends the coil in air and still retains the rigidity needed for support. This new design eliminates 95% of the dielectric losses. We feel that this new design is so unique that we have filed a patent application on it.

In addition, we use 10 Ga. silver plated wire to reduce resistive losses to a minimum.

In order to handle higher power for amateur use, we used the more efficient direct coupling method of matching, rather than the lossy capacitor coupling. With this method the Wilson 1000 will handle 3000 watts of power.

The Best You Can Buy

So far you have read about why the Wilson 1000 performs better, but it is also one of the most rugged antennas you can buy. It is made from high impact thermoplastics with ultraviolet protection. The threaded body mount and coil threads are stainless steel; the whip is tapered 17-7 ph. stainless steel. All of these reasons are why it is the best CB antenna on the market today, and we guarantee to you that it will outperform any CB antenna (K40, Formula 1, you name it) or your money back!

*Inductively base loaded antennas

**Call for details.

Lockheed - California Company

A Division of Lockheed Corporation
Burbank, California 91520

Wilson Antenna Company Inc.
3 Sunrise Way, Unit A-10
Green Valley Commerce Center
Henderson, Nevada 89015

Subject: Comparative Gain Testing of Citizen's Band Antennas
Ref: Rye Canyon Antenna Lab File #670529

We have completed relative gain measurements of your model 1000 antenna using the K-40 antenna as the reference. The test was conducted with the antennas mounted on a 16" ground plane with a separation of greater than 300" between the transmit and test antennas. The antennas were tuned by the standard VSWR method. The results of the test are tabulated below:

FREQUENCY (MHZ)	RELATIVE GAIN (dB)	RELATIVE POWER GAIN (%)
26.965	1.30	35
27.015	1.30	35
27.065	1.45	40
27.115	1.60	45
27.165	1.50	45
27.215	1.50	50
27.265	1.75	50
27.315	1.95	57
27.365	2.00	58
27.405	2.00	58

**58%
MORE
POWER GAIN
THAN THE
K40**

Individual test results may vary upon actual use.

CALL TODAY

TOLL FREE: 1-800-541-6116

FOR YOUR NEAREST DEALER

Wilson 1000

DEALERS Exclusive dealer areas still open

Roof Top Mount.....\$99⁹⁵ Little Wil.....\$299⁹⁵

Trunk Lip Mount.....\$69⁹⁵ Wilson 2000 Trucker.....\$99⁹⁵

Magnetic Mount.....\$79⁹⁵ Wilson 5000 Trucker.....\$99⁹⁵

500 Magnetic Mount.....\$99⁹⁵ Call About Fiberglass!!!

Wilson 5000 BaseLoad — NOW AVAILABLE!

Wilson

ANTENNA INC.

1181 GRIER DR., STE. A
LAS VEGAS, NV 89119

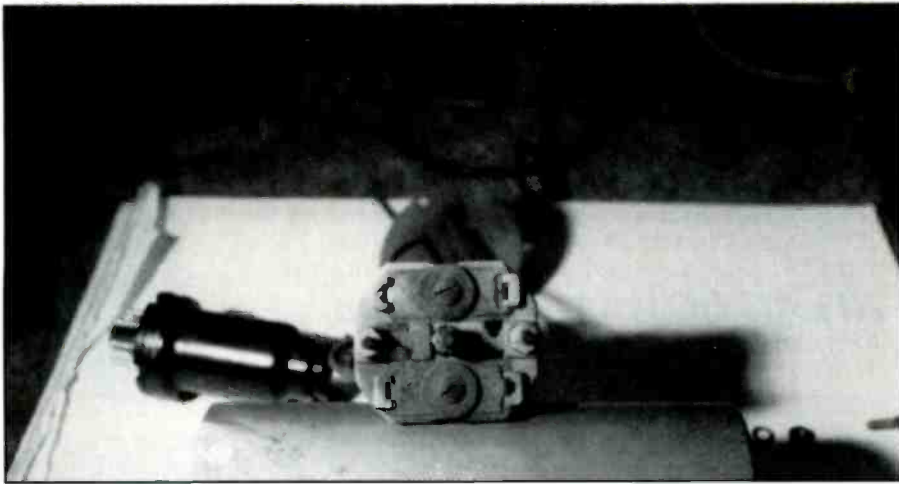

Photo B. Peeking inside this vintage IF can shows the layer of crud that builds up over the years on the mica trimmers. These capacitors should be cleaned and flushed out to ensure good performance.

they also should be cleaned in the same manner. Later IF transformers use adjustable ferrite metal cores for alignment.

You may add a tiny drop of oil—Three-in-One brand is good—on any of the tuning shaft sleeve bearing points used to drive the dial cord. Be careful not to get any oil on the dial cord or the portions of the shaft where the dial cord rides, or slip-

page will result. Likewise, add a small drop of oil on the shaft of the volume control where it enters the control bushing. Remove any traces of excess oil with a soft tissue.

The pilot lamp should be changed if it shows any signs of age. Pilot lamps with many hours of service will show a darkening on the inside of the glass bulb. The most common lamp type found in these sets is the type #47, and these lamps are good for about 2000 hours of service. Always use the correct lamp for the radio you are working on.

Aligning the Radio

SAFETY NOTE! Aligning an AC/DC chassis involves connecting external test

“Now you can take your Emerson out to the porch and catch an afternoon baseball game while you admire your handiwork. Don’t forget the iced tea!”

equipment to the radio chassis. For protection against electrocution an isolation transformer must be used! The test points will be near dangerous high AC and DC voltages under the chassis. Be careful.

The performance of any set will be only as good as the alignment of the various RF stages. To do a proper alignment you will need two things; a good RF signal generator; and secondly, the alignment procedures for the radio. Space allows only a cursory coverage of alignment techniques; we will revisit this subject in greater detail in the future.

For a simple broadcast band superhet such as the Emerson, the IF stages are aligned first. The signal generator must be set to the exact IF (Intermediate Frequency) for your set. This is typically 455 kHz, but other IFs were popular. You can couple the RF output from the signal generator into the external antenna connection and to the chassis ground on the Emerson. The single-tuned RF stage used in these radios will allow enough IF signal to pass through for alignment purposes. If there is no external antenna wire, couple the RF output through a .05 mFd capacitor to the RF stator plates on the tuning capacitor.

You can tune the IF stages by ear for

**FREE
SAMPLE
COPY!**

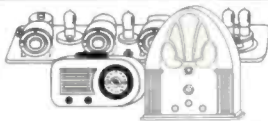

ANTIQUE RADIO CLASSIFIED

*Antique Radio's Largest-Circulation
Monthly Magazine*

Articles - Classifieds - Ads for Parts & Services
Also: Early TV, Ham Equip., Books,
Telegraph, 40's & 50's Radios & more...

Free 20-word ad each month. Don't miss out!

1-Year: \$36.95 (\$53.95 by 1st Class)
6-Month Trial - \$18.95. Foreign - Write.

A.R.C., P.O. Box 802-T11, Carlisle, MA 01741
Phone: (508) 371-0512; Fax: (508) 371-7129
Web: www.antiqueradio.com



CALL OR FAX TODAY
FOR OUR FREE 52 PAGE CATALOG
(602) 820.5411 • Fax (800) 706.6789

ANTIQUE ELECTRONIC SUPPLY™ LIMITED PARTNERSHIP

6221 S. Maple Avenue Tempe, AZ 85283

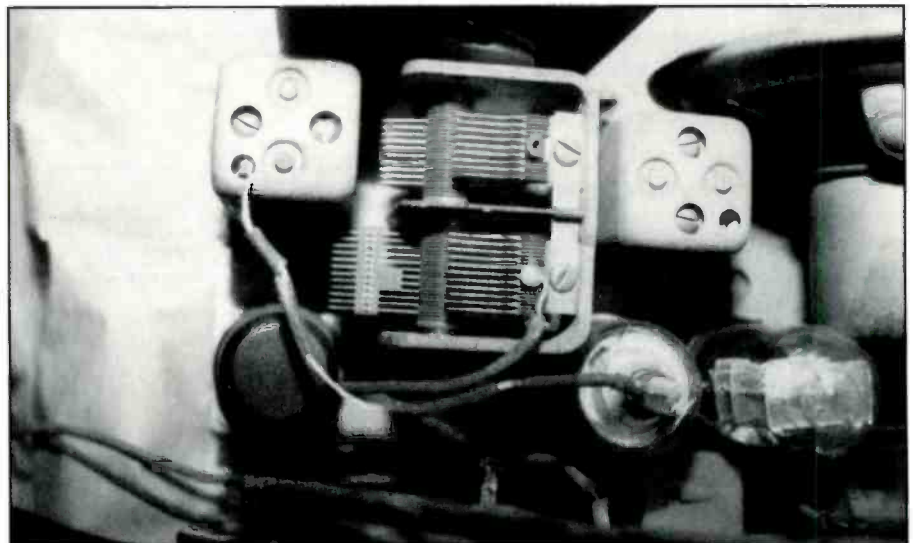

Photo C. Alignment points for the Emerson. First IF transformer is in the upper left; note the flying secondary lead going to the IF tube grid cap. Second IF transformer is to the right of the tuning capacitor.

maximum loudness, but for best results use a VTVM (Vacuum Tube Voltmeter) or voltmeter on the AGC line. **Figure 1** shows the test point where you may monitor the ACG voltage. As the IF stages are tuned to resonance, the AGC voltage will increase in a negative direction, to a maximum of about -7 Vdc. Keep the signal generator output level set so the AGC action is visible on the meter, but not so strong as to saturate (overload) the stage. Repeat the alignment until no further improvement is noted.

If you haven't touched the original IF stage tuning, or don't have access to a signal generator, you can often get by with a simple repeating of the stages. This is done by tuning into a strong local station and while metering the AGC voltage adjusting the IF transformers for maximum AGC voltage. It is best to use the signal generator—the radio's ability to track properly across its tuning range relies on the IF stages being set to the proper Intermediate Frequency! Avoid the temptation to troubleshoot by playing with alignment settings.

RF and LO Alignment

The first step is to be sure the dial pointer is correctly set on the tuning capacitor shaft! Set the tuning for the maximum end of rotation—the dial pointer should be parallel to the horizon for correct mechanical alignment on this 0 to 180-degree Emerson dial scale.

More complex sets require alignment for both the high and the low end of each band's tuning range for both the Local Oscillator and RF stages. RF alignment of the Emerson radio requires adjustment at one setting at the high end of the tuning range. You can use the signal generator for this, or a local station operating between 1500 and 1600 kHz. The best alignment frequencies are usually given in the Rider manuals.

A local daytimer running on 1600 kHz provided a convenient alignment signal at my location. I set the Emerson's dial to exactly 1600 kHz, and then carefully tuned the LO (local oscillator) compression trimmer capacitor (the one mounted on the stator plates of the tuning capacitor) until I could faintly hear the station. While watching the AGC voltage, I then tuned the RF stage compression trimmer for strongest (highest AGC voltage) reception. This completed the alignment of my Emerson.

If you have difficulty deciding which trimmer is for the LO, and which is for

the RF, the loop antenna usually has a lead that connects to the RF stator plate connection. In some radios, the LO rotor and stator plates are smaller than those in the RF section. The LO stator connects to a small wax-covered coil under chassis.

It's just about time to put your Emerson back into its bakelite home. But first, you might want to give the bakelite finish a good cleaning and polish! Never use strong detergents, or anything with an alkaline PH, to clean bakelite—you will

destroy the luster. Don't use abrasives! I use furniture polish or Armor All on my bakelite radio cases. Some collectors swear by the Armor All, and allow the excess to sit on the bakelite for several hours before wiping off the excess.

There! Your "classic" is ready for many more years of service. Now you can take your Emerson out to the porch and catch an afternoon baseball game while you admire your handiwork. Don't forget the iced tea! Until next time . . .

JGAR PISTOL
UPS SHIPPABLE



JG 3 + 3 STAR
UPS SHIPPABLE



WE'VE GOT THE FIELD COVERED!



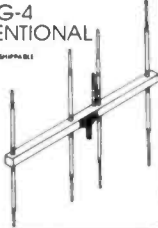

JO GUNN
Antennas

JG-4 CONVENTIONAL
UPS SHIPPABLE

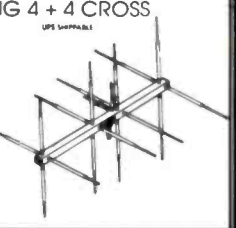

JG 4 + 4 CROSS
UPS SHIPPABLE



Route 1 Box 32C, Old Hwy 82.
Ethelsville, Alabama 35461
(205) 658-2229 fax (205) 658-2259
Hours: 9am - 5pm (CST) Tuesday - Friday

Other Models & Sizes Available in 10 or 11 Meters
 Call or send \$2 for Complete Catalog and Pricing of Antenna
DEALER INQUIRIES, PLEASE CALL

The Pirate's Den

FOCUS ON FREE RADIO BROADCASTING

North American Pirate Relay Service Gone

This month we have the unfortunate news that NAPRS—the North American Pirate Relay Service has ceased operating and won't be back. In a news release from the station operator, Dick Pistek blamed his changing interests, as well as what he called "too much competition for air time from the likes of WARR, WPRS." NAPRS relayed a number of foreign-based pirate stations during its lifetime—stations we would probably not have been able to hear otherwise. It's really too bad.

Loggings Received for This Issue

Radio Three, 6955 USB at 2017 to 2159 heard by Mike Layden in Pennsylvania with some CW QRM in the background. This one demands so much information for a QSL that it is virtually impossible to meet their requests (i.e. naming every member of every band played and their hair color, etc.). Jim Bailey in Wisconsin found this on **6945 USB** with "Sal Amonniac" as the announcer, who raved about not paying royalties to music copyright owners.

Radio Free Speech showed up several times in the Layden log: **6955** at 1723–1727, 7417.3 at 2216–2230, **6955** at 2247–2257 with Captain Sinbad the Sailor," **6955** at 1731 to 1755, **6955** at 1830 as the "Radio Free Speech Relay Service" and **6955** at 2204 sign on. Jerry Coatsworth in Ontario had them on **6955** at 1414 sign on to 1422, signing on with the 20th Century Fox theme.

Radio Euro Geek was another heard by Layden, on **6954.8 USB** at 2042 to 2113 with what Mike terms "extremely slick" IDs and production, mad cow disease song, IDs given in at least 10 different languages. QSLs to P.O. Box 28413, Provincetown, RI 02908.

The Talking Pirate was heard by Bailey on **6955 USB** at 2145 to 2155 sign off. They played Jeff Foxworthy's comedy bit "Out of the Gene Pool." Coatsworth had this one on **6955 USB** at 1805 to 1813 sign off, "broadcasting from the mid-

Atlantic states" and reasons why you might be a redneck.

WPRS, 6955 USB, was picked up by Jerry Coatsworth in Ontario at 1900–2032.

WREC, 6955 USB was logged by Coatsworth on at 2045 to 2125 with a "Dagnet" parody sketch. And, again, on

6955 at 1543 to 1614. And yet another time at 1944 to 1955 with guest IDs by Jack Boggan and Radio Animal. Layden had this at 1900 to 1945 with such station IDs as "This is not an accident, it's a wreck—WREC."

CITH, 6955 USB came on right after WREC signed off—possibly from the



Mike Layden in Pennsylvania received this QSL from Up Against the Wall Radio.

same transmitters, says Jerry.

Ed Rausch had **Radio Pirana, 6925.5** from South America at 0330 with announcer Jorge Garcia playing pop music, giving English and Spanish IDs. He announced the Blue Ridge, PA and Wuppertal (Germany) addresses and also gave a new one: Casilla 2571, 1000 Buenos Aires, Argentina.

Radio Eclipse was heard by Rausch on **6954** at 1614 with old Pearl Harbor news clips, and from FDR's "Infamy" speech. They didn't give an address. Layden had them from 1608 sign on to 1625 close, talking about Radio Fusion Radio being jammed by a Texas station. No address was heard.

Layden had what may or may not have been **WLIS, on 6955 USB**, at 0023 to 0047. They announced as WLIS but it sounded like bits and pieces of the real WLIS but with another announcer's voice spliced in. They used the guitar signature of "Guns n Roses" almost as an interval signal. They played "Sweet Child 'O Mine" and mentioned Pat Murphy. Jerry Coatsworth found them on **6953 USB** at 2117 to 2150 sign off.

Radio KAOS was heard by Layden on

6955 USB at 0130 to 0145 when the signal was lost. Joe Mamma was the live host. The station was heard a few days later at 0023 with the ID "This is KAOS Live in Concert."

Layden had **Up Your Radio Short-wave on 6955** at 1735 to 1755 with an old Texaco commercial, Jack Benny, a mail-bag feature and "Top Ten List of Undeniable Truths." Reception reports go to the Blue Ridge Summit address. Coatsworth had this on **6952 USB** at 1543 to 1550 with the Alan Sherman Project and "I'm in the Mood for Love."

WDRR—We're Desperate Rock 'n' Roll was spotted by Layden listening on **6955** from 1630 sign on to 1642 sign off. Mike says there were "about a million audio clips with canned laughter on top."

Pirate Radio Boston was heard by Layden on **6954.5** from 1645 to 1731 with Charlie Loudenboomer and Mr. Excellence playing reggae and running a contest to win a hot and cold mug. The address is P.O. Box 146, Stoneham, MA 02180. He also heard this one on **6954.5** at 1543 to 1630 sign off. Coatsworth had this one at 1846 to 1857 with listener's letters.

WRV, the Radio Virus, was heard by Layden on **6955.4** at 1830, hosted by Pirate Pete.

Rock and Roll Radio was found by Layden on **6955 USB** at 1446 to 1450 close with the Doobie Brothers. Then they went off abruptly.

Hitchhiker's Guide to the Galaxy Electromagnetic Emission, was logged by Ed Rausch on **6955** at 1520 with an episode of the famous "Hitchhiker's Guide to the Galaxy."

WMPR—Micropowered Radio, was found by Rausch on **6955** at 1545 with an ID and techno dance music.

Ed also caught **Radio Beaver on 6955 USB** at 1610 featuring Bucky Beaver.

WJDI was heard by Jerry Coatsworth on 1620 medium wave at 0450 to 0655 with funny commercials and old hits. ID'd as "WJDI, 15,000 watts—king of the pirates."

WGLR was heard via WPN on **6955.2** at 1520 to 1554 with host Guy Gardiner playing Elvis and the macarena.

Thanks to those who took the trouble to report this month. Let's hear from more of you—more often!

Happy pirate hunting! ■

We don't make SCANNERS or the ICOM IC-R8500 RECEIVER - We make them better -

DELTACOMM I-8500 Communication Manager for the ICOM IC-R8500 communication receiver. With speed as a design goal DELTACOMM's QUICK LOG function will log signal level, frequency, mode, date, time and optional Global Positioning System (GPS) coordinates at speeds in excess of 2400 channels per minute. Here are a few examples of the many advanced features DELTACOMM I-8500 has to offer.

- Load 40 channels of information including ALPHA NUMERICS into one of the R8500's memory banks in 3 seconds.
- Separate volume level, resume scan delay and maximum monitor delay plus 40 character information field for each scan channel.
- Priority channel operation samples at 2.5 second intervals.
- Multi-receiver control will hand off active frequency to next receiver on line. Able to control up to 125 ICOM receivers (optional).
- Traditional scanning is a thing of the past with our CYBERSCAN feature, used to track systems employing frequency hopping.
- Activity log function automatically records and calculates total spectrum usage time.
- Unique search operation stores all frequencies found active and then automatically skips those frequencies during the remaining search cycles. This feature eliminates redundant logging.

Visit our Internet Web Page or Phone/FAX us for program features, new product releases and pricing schedule. DELTACOMM is available for ICOM R9000, R7100, R7000, R71, R72, IC-735 (features vary with type of radio). Also check out our DELTATONE 2.0 repeater programmer.

<http://www.execpc.com/~deltacom>



Delta Research



Box 13677 - Wauwatosa, WI 53213 - FAX/Phone (414) 353-4567

CIRCLE 69 ON READER SERVICE CARD

THE MONITORING MAGAZINE

Get A New Image

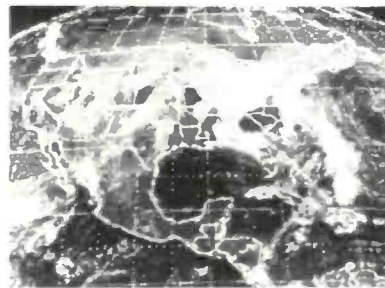

PC HF Fax Plus \$129

PC HF Fax Plus is a simple, yet comprehensive HF system that receives Fax, RTTY, CW, and AMTOR on an IBM PC or compatible. It includes an FSK demodulator, advanced signal processing software, tutorial audio cassette, and complete reference manual. Just plug the demodulator into a serial port, install the software and get text and wvld Images on your PC.

PC SSTV \$149.95

PC Slow Scan Television is a complete system for sending and receiving full color amateur SSTV. The package includes an SSTV FSK modem, SSTV software, image capture utilities and reference manual. All popular formats are supported including Robot, Scottie, Martin and AVT. The system requires a 286, 386 or faster PC with VGA or super VGA display.

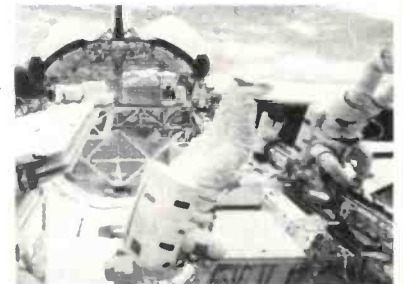

Have It All For Only \$199.95

For a limited time we are offering both software packages with a single FSK modem for under \$200. This combination offer will let you send and receive the popular HF image and text transmission modes.

Call or write for our free catalog. Visa and Mastercard welcomed.

Software Systems Consulting

615 S. El Camino Real, San Clemente, CA 92672

Tel.(714) 498-5784 Fax.(714) 498-0568

website: <http://www.sscorp.com> e-mail: support@sscorp.com

CIRCLE 86 ON READER SERVICE CARD

April 1997 / POPULAR COMMUNICATIONS / 23

Books You'll Like

Pirate Directory Updated

The current (1996) Eighth Edition of the Yoder/Zeller *Pirate Radio Directory* covers all 125 short-wave pirate broadcasting stations known

to have been operated during 1995. Many are still active.

The directory lists programming formats, deejay names, operating frequen-

cies, veri information, and other relevant data. An intro section by George Zeller details the special considerations of pirate station DXing, including the best ways to obtain QSLs from the undercover stations.

Many pirate station QSL cards are illustrated in the book. An appendix lists all of the stations along with their most recently reported operating times and frequencies. Another appendix shows all pirate broadcasters covered in previous editions of the book dating back to 1989.

So, if you want to know about monitoring *The Voice of the Daleks*, which proposes to destroy life on this planet, check out this book. Or, learn about pirate station KDED, which plays only Grateful Dead music. And then you may be ready to find out about The Crooked Man. In a world of odd stations, *The Crooked Man* is one thought by many pirate buffs to be the freakiest station ever!

The 1996 *Pirate Radio Directory* is \$12.95, plus \$3 s/h from Tiare Publications, P.O. Box 493, Lake Geneva, WI 53147. Phone: (414) 248-4845.

National Capital Scanner Directory Update

Scanner Master's big 382-page scanner guide to the District of Columbia, Maryland, and Virginia has been updated into its Fourth Edition.

Edited by Lynn Burke, Allen Cole, John McColman and Richard Rowland, the directory is a huge reference to public safety, news media, transit, public utility, medical, recreational, cultural, plus many cultural, federal, and other services in the National Capital area.

There are plenty of maps, CTCSS tones, repeater input frequencies, call letters, codes, trunking system outlines, unit ID's, channel numbers and usages, provided where possible. You really have a lot of information here far beyond basic licensee data, and it's put together very well with depth and understanding.

It's available for \$29.95, plus \$5.95 s/h, from Scanner Master, P.O. Box 428, Newton Highlands, MA 02161. Phone: 1-800-722-6701.

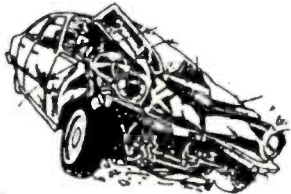

When seconds count, REACT® needs you...

...to summon help for an injured motorists, an elderly woman trapped in a fire, a trucker stranded in a blizzard, a drowning child!

As a REACT volunteer CB radio monitor you may be the only communications life-line for someone in serious trouble. You relay messages from those desperate for help to police or other emergency services.

Your REACT Team will also use CB and other radio services to provide safety communications for events like parades, marathons and even balloon races. The fellowship with other REACT members at Team meetings and annual conventions is an added bonus.

Volunteer. Join Today!

Add a New, Exciting Challenge to Your Life. Help Save Lives and Property!

REACT® International, Inc.

Tel (316) 263-2100

FAX (316) 263-2118

P.O. Box 998, Wichita, KS 67201



Radio Resources

BY BILL MAULDIN, WG4R
e-mail: 75750.1331@compuserve.com

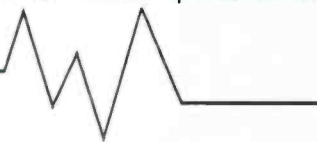

INTERESTING THOUGHTS AND IDEAS FOR ENJOYING THE HOBBY

A Visit to Disney World

The extensive communications systems of Walt Disney World near Orlando, Florida can match or beat many of the state-of-the-art radio dispatch centers used in some of our larger cities. The equipment is modern, well coordinated, and designed to do the job of running and protecting the number one vacation site in the United States.

Every December, I pay a visit to the Magic Kingdom. Of course, I would never think of going anywhere without my scanner and my dual band amateur transceiver. Some of the most interesting listening in Florida can be found in and around Disney World. There is one thing really unique about Walt Disney World that most visitors don't realize. In the beginning when the State of Florida was trying to entice Walt to bring his new entertainment kingdom to the Orlando area, they granted Disney some very special privileges. Disney created Reedy Creek, and Florida agreed to make the area a self-governing body. Reedy Creek is very much like any other Florida city except they have some very special exceptions in some of their basic requirements. Since this is a radio related column, I will leave you with that initial thought. I just want you to be aware that Reedy Creek has almost total control over all matters within the boundary of the Disney-owned land. It is truly an exceptional area in many unusual respects.

The radio systems of Walt Disney World are as varied as one might expect for an active municipal city. The Reedy Creek Public Safety system is state of the art. The trunked system is found on 800 MHz. The Park Security system and some of the Park Operations system is also found on the trunked 800 MHz channels. Unless you are using one of the new "trunk following" scanners, you will have some degree of difficulty in monitoring the system, however, here are some suggested frequencies:

851.3125,	851.8875,	852.3625,
852.6375,	852.8125,	852.7375,
852.9625,	853.4875,	853.7125,

854.3375,	855.0375,	855.1875,
855.6875,	855.7875,	855.8875,
856.9125,	857.7875,	858.8125,

and 859.7875 MHz.

This is not a complete list, but with a little luck, you will be able to follow some of the action. The new Uniden "Trunk Tracking" scanner could possibly make listening much easier. I have not seen one of the new Uniden scanners as this article is being written, but I understand the performance is impressive.

A considerable amount of radio dispatching within Disney World, MGM Studios, EPCOT, and the Lake Buena Vista is still done on UHF. Since I did not have one of the new "trunk following" scanners with me during my visit, I listened to more UHF communications than 800 MHz. Listing all of the frequencies in this column would give you a guide for listening in on the activity, however, your listening enjoyment would certainly be increased considerably if you would purchase one of the commercially-printed frequency directories available today and take it with you during your visit. *Monitor America* and *Police Call* both have very good basic frequency lists. The advantage in using a complete area directory will give you many of the frequencies used by Disney, plus those of the local public safety and fire departments.

Although I did take a copy of *Monitor America* and *Police Call* with me, I also did considerable searching with some very interesting results. Here are some suggested starting frequencies.

The Disney World Parade feeds normally take place on frequencies between 206 and 212 MHz. The activity lasts long enough to allow you to do just one or two searches and come up with the active channels. Wireless microphones in the Magic Kingdom can normally be found between 450 and 450.500 MHz. Using those two search limits will capture some interesting finds.

There are several basic frequencies that have been active ever since the gates opened on that first day. These are UHF frequencies and can be easily received.

OPS 1 is 462.550 MHz and is normally used now mostly for paging.
OPS 2 is 462.575 MHz and is used by the Monorail for controlling the car movements (some monorail traffic also takes place on 462.550 MHz).
OPS 3 is 462.625 MHz and is the primary transportation dispatch frequency.

Another interesting and often used frequency pair is known as "Entertainment:"

Entertainment F-1 is 461.600 MHz—Used by resorts, Ft. Wilderness, and others.

Entertainment F-2 is 461.300 MHz—Used generally for parade dispatch and arrangement.

Entertainment F-3 is 464.9375 MHz—Use is mixed.

Entertainment F-4 is 464.500 MHz—Use is mixed but active.

Although considerable public safety and park security radio traffic is now on the 800 MHz trunked system mentioned earlier, you will still find some basic security traffic on the two UHF channels that initially made up the security system.

Security F-1 is 464.400 MHz and carries radio traffic related to the Travel Center.

Security F-2 is 464.125 MHz and is quite active at times with routine traffic.

A Fully Equipped Security Force

Disney has an impressive security and public safety department. When you visit Disney World, the average visitor normally only sees the uniformed, unarmed, helpful security officers. Behind the scenes, there is an impressive security and law enforcement force. Working in plain clothes, this team of well trained professionals deals with the crimes that take place on the Reedy Creek property. The biggest problem in the park, according to one officer that I talked with, is theft and



There's a lot going on behind the scenes at Disney World. Bring along your scanner to catch all the action! (Photo by Nancy Barry).

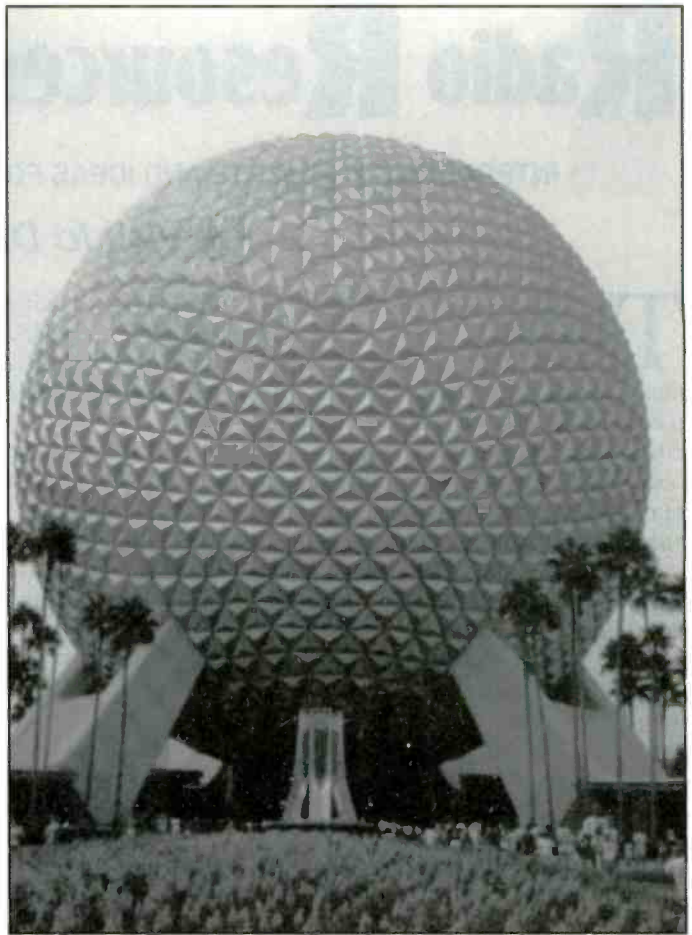

EPCOT also provides plenty of action-packed scanning. (Photo by Nancy Barry).

shoplifting, however, the fully-equipped security police have full arrest powers and handle all major investigations that take place within Reedy Creek. When you consider the massive numbers of people in the area, one would also have to consider the potential for criminal activity.

Your safety, well being, and the protection of company interests are their number one priority. Keeping the officers other than the unarmed, helpful security personnel out of sight and maintaining a low profile is key to maintaining the magic of the park.

Monitoring the security communications can be very interesting. Disney security personnel also make considerable use of pagers and cellular telephones, just like any other major police agency. Some of their surveillance communications can surpass those of a high-crime city.

Disney goes to considerable lengths to

insure that the planned visit to the parks and entertainment centers is enjoyable to all. Monitoring the communications that makes all of this come together can be truly interesting and as entertaining as some of the rides or the shows for the devoted radio scanner buff. My suggestion is to keep your scanner as low profile as possible. By all means use an earphone so you will not disturb those around you when you are at a parade or show. Plan your search scanning well ahead of your attendance, and make notes on what you find. Watch for Disney employees that are using radios. The band that they are operating on can be determined by the type of antenna on the handheld or on the vehicle. If possible, get close enough to the radio user to hear some of the traffic on their radio, and then do some quick searching to see if you can find the operating channel. The Opto Scout comes in very handy if you can get close

enough. The Optoelectronics Xplorer is even a better choice. As you capture a frequency, make certain you have a way to note the catch so you can enter it in your scanner later.

I used my Opto Scout several times during my visit. I found that a telescope style antenna let me get more "captures" and to quickly change from one frequency band to another without changing the rubber duckie antenna. Several Disney radio users were kind enough to key their handheld walkie talkie for me when asked. A quick frequency capture is easily done in this manner. Just hold the Scout or Xplorer close to the activated walkie talkie and you have the user frequency. Remember to do the math needed for the band in use. A capture of 469.125 MHz during the transmission of a walkie talkie would tell you that the user was on the 464.125 MHz Security F-2 frequency. The Opto products are most useful when trying to capture a trunked 800 MHz frequency.

Although this article relates to using a scanner in Disney World in Orlando, the basic thoughts and suggestions will apply

"The equipment is modern, well coordinated, and designed to do the job of running and protecting the number one vacation site in the United States."

"There is one thing really unique about Walt Disney World that most visitors don't realize."

to using a scanner in any entertainment center. Keep in mind that many entertainment centers do not take kindly to the use of scanners in their park. Again, it's important that you keep your handheld scanner out of sight. Keeping a low profile is a must if you want the maximum ability to enjoy the action behind the scenes. Many entertainment centers prohibit scanners, walkie talkies, and other radio related devices inside their facility. Although these parks do not generally have signs at the gate saying "scanners prohibited", they will quickly approach you and offer to "check your scanner" until you leave the facility. Playing it safe and keeping your scanner out of sight is my number one suggestion for getting in on the radio related action.

A friendly conversation with an employee who is carrying a walkie talkie can bring about some excellent results and a wealth of information, especially if you

aren't standing there with your scanner on your belt. None of the radio-using employees that I encountered seemed concerned with the Optoelectronics Scout that I carried, and several were kind enough to key their radio for a quick frequency readout following a few minutes of friendly conversation. I spent the first day of my visit without my scanner by my side. This gave me a chance to look at the types of radios used by employees. I was also keenly aware that I saw no scanners in use by any visitors. This is a good indication that low profile use is a must.

All major theme parks have their own communications systems. The Orlando area not only has Disney, but Universal Studios and Sea World as well. Universal uses a DPL UHF system, generally speaking, but seems to be adding a 900 MHz

"Monitoring the communications that makes all of this come together can be truly interesting and as entertaining as some of the rides or the shows for the devoted radio scanner buff."

trunked system. Sea World of Florida can be found mostly on UHF with some 900 MHz trunking.

There is an amateur radio repeater located at the park, and local hams are often there to give you directions and suggestions on how to get to your destination. You can make the most of your Disney visit by asking questions and monitoring the local repeater. I was once again made keenly aware that there were no hams seen in the park with a handheld hooked on their belt. Most hams that were using the Disney ham radio repeaters were doing so from their car and not from within the park property by walkie talkie.

If you are a low profile scanner user, with some advance planning, there is an exciting world of listening excitement inside these modern entertainment centers. My annual visit was made much more enjoyable because I enjoy communications as much as the sight of Mickey and Minnie. Just use common sense when visiting Disney with your scanner, be low profile, and also be considerate of others, and don't do anything "goofy" while you're there! Some of your experiences would be most welcome for a future article on this subject!



LENTINI COMMUNICATIONS, INC.

Toll Free
1-800-666-0908

RELM HS 200

Multi-Band Programmable Scanner

- Multi-Band, Programmable Scanner, 13 Band Coverage From 26.000 MHz Thru 960.000 MHz.
- Includes 6 Meters and Aircraft.
- PL/CTCSS and DPL/DCS included!**
- 200 Channels, 10 Banks, 10 Priority Channels.
- Birdie Lockout, Channel Lockout.
- Scan Speed Up To 100 Channels Per Second.
- HS200 Comes With A Metal Belt Clip, AC Adapter, Ear Piece, & Carrying Strap. (4 AA Batteries Not Included).
- Many Other Features.



\$249.95
UPS included.

MAXON

GMRS 210+3

- 10 UHF Channels, CTCSS
- 2 Watts Output (5 watts at 12VDC)

\$179.95 UPS incl.

SM-2000 Series

Synthesized Scanning Mobiles UHF & VHF Versions Available

- 25 Watts
- 4 Channels
- CTCSS/DCS

Call on Maxom FRS Radios!
\$289.95 UPS inc.

UNIDEN BC9000XLT

\$379.95 delivered

UNIDEN BC3000XLT

\$359.95 delivered

YAESU FT-50R

Ultra Compact Dual Band Handheld

Receive: 76-200MHz, 300-540MHz
590-999MHz cellular blocked

Transmit: 144-148MHz
430-450MHz

- AM Aircraft Receive
- Digital Coded Squelch
- High Speed Scanning
- CTCSS Encode (Decode/w/FTT-12)
- 112 Memory Channels
- Much, Much More!

GRUNDIG

Shortwave Yacht Boy 400

Advanced Compact AM/FM/SSB Shortwave

- Top Performance In A Portable Shortwave Receiver
- Yacht Boy 305 ALSO IN STOCK!

CALL FOR PRICING
CALL FOR DISCOUNT PRICES ON DRAKE AND SONY

SANGEAN

ATS909 New From Sangean AM/FM/SSB Shortwave

- 306 Memories
- 28 SW Pages Preprogrammed
- Full RDS Reception

Loaded With Features
CALL FOR PRICING!

AR8000

CALL FOR PRICING

AOR

AR5000

IC-R10

CALL FOR SPECIAL PRICING

IC-R8500

Conn Sales Infor. & Tech Help
860-666-6227

21 Garfield St. Newington, CT 06111
C.O.D.'s OK — SAME DAY SHIPPING

HOURS: M-F 10am - 6pm
SAT 10am-4pm
UPS Ground (48 states)

CIRCLE 74 ON READER SERVICE CARD

The Computer Corner

RECEIVER CONTROL, SOFTWARE AND MORE

Looking at The Scancat-Gold for Windows and Locating Web-Sites for Scanner Enthusiasts

This month we are going to take a look at a computer control software package named Scancat-Gold for Windows, Version 7.01. This program is designed to run on IBM compatible PC's with MS Windows 3.1 or greater, at least 4 Mb of RAM, and 5 Mb of free hard drive space. A radio with a built-in interface, or an external interface is then connected to a serial port of the computer running Scancat. I used Scancat on a 486/33 notebook and a desktop, both with 8 Mb or RAM while writing this column. Scancat does NOT use copy protection, and installation on a user's home and notebook systems doesn't present a problem.

Com ports 1-4 are supported. Installation was quick and easy! The software comes with a 124 page illustrated, indexed and cross-referenced spiral bound manual, that will lay flat on the table in your shack. On-line help is provided by both a Windows help file, and selectable balloon tips that pop up when the mouse is on buttons and fields. The author is also available for support help at (318) 686-0449 M-F 9 a.m.-2 p.m. Central or via e-mail at <scancat@scancat.com>.

Supports Many Radios!

The software supports many radios including scanners and radios from AOR, Drake, ICOM, Kenwood, Yaesu, NRD, Lowe, WJ, and RadioShack scanners equipped with Optoelectronics OS456 or OS535 boards. This release supports the new ICOM R8500, AOR5000, and the Opto Scout version 3.1 Complete 800 MHz coverage is possible on the AR2700 and AR8000. Two ICOM units can be controlled at the same time if one covers HF, and the other VHF/UHF, or you are scanning multiple banks, and you are using the CT-17 interface. CTCSS and DCS tone search is supported on RadioShacks equipped with the Opto board, or Icoms equipped with the Opto DC-440 Tone reader and the CI-V interface. Unlike software that only supports a particular radio, Scancat



The new Scancat Gold for Windows supports more than 50 popular radios from AOR, including the AR-8000 and 5000; Drake's R8/R8A; Kenwood, ICOM, including the ICR10, R-71A, R-7100 and R-8500; Lowe, Yaesu, Watkins Johnson, and JRC (NRD-525/535) all within one program.

can be used with multiple radios, a nice feature when you own more than one radio with an interface.

I used Scancat on my AR8000, Drake R8, ICOM R7100, and an Opto OS535 equipped PRO-2035 while writing this column. A nice feature is that the scan files you create with Scancat, can be used with any radio it supports. It will translate any modes not supported on the radio to a compatible one.

The program can import data from the Percom Spectrum CD-ROM, Mr. Scanner's CD-ROM, Grove's FCC dB, Tom Sundstrom's Schedules, Dbase, MS Access, comma delimited, and Btrieve files. This is especially handy if you have files from other software packages, trade files with others, or use FCC databases. This release of Scancat can also SCAN directly from Dbase, MS Access, Foxpro, and Btrieve files. A utility for converting text files into frequency files, SCANPORT, is also included.

Controlling the Radios

The software allows a user to control the radios tuning, via the keyboard and mouse. Panels of buttons on the display allow access to many features by simply clicking on them with a mouse. A search range between a lower and upper frequency may be programmed, and the stepping increment, delay times, and other parameters may be specified. These parameters may be set on a per record basis when using a scan file. A file of specified frequencies may be scanned, and multiple files of frequencies may be linked together for scanning. Scanning by bands, and scanning of multiple bands is also possible. Twenty preprogrammed bands, and many preprogrammed scan files with Shortwave, marine, utility, and hot frequencies are included with the software, or available for download from the Scancat web site. Prior versions of Scancat were limited to 400 frequencies in a scan

file, but this version does not have that limitation when scanning a disk file. A database "browser" window is used for looking at or working with these files. Individual or global settings can be edited. Auto mode and increment features can be enabled to help when using a database file that lacks these settings. A blank file can be used to enter frequencies from scratch, as the target of an imported file, or because most of the radios supported can have their memories read, the contents of a radio may be saved into a disk file.

An existing file may be loaded, edited, sorted, and for most radios, loaded into their memories. A scan file may be searched for text, sorted by field, printed, or exported. Search results can be saved into a disk file, and the logged details of scanning can be analyzed. Different logging options are supported including ones for interactive and unattended monitoring. These can be a powerful tool for the user that wants to collect information on the signals they've monitored.

Logging results may be printed or saved to a file on disk. An automatic feature is provided for identifying and locking out any birdies on the receiver being controlled. This feature remembers to skip these frequencies any time this radio is used in the future, and saves the user time and aggravation. The main scanning window features slider bars that allow you to adjust the dwell, hang, delay, and command timings on the fly. This is great for making adjustments while scanning to optimize performance.

Spectrum Analysis Too

Spectrum Analysis is supported on radios that provide a squelch and signal strength information via their interface. Hits and signal strengths are easily seen using this visual display. A new feature is the ability to display a graphic file as a map, and define areas on it that when clicked will instantly tune your radio to a frequency. You can define up to 1000 hot spots on the BMP format graphics file. Alarms can be set for records in a scan file, and when they are active, the user is notified. A terminal emulator named Quickterm is included for use with a TNC or similar demodulator while running Scancat. It features multiple windows and macro features.

Using the Scancat

I found Scancat to be easy to install and use. Its importing and logging features, as

well as support for many different radios are strong points. The user's manual and telephone support are strong reasons for a person considering a computer control setup for the first time to take a good look at Scancat Gold for Windows.

Users of Opto equipped scanners who want the quickest scanning speeds possible will find that Scancat Gold for Windows doesn't scan as fast as some other software products, especially those that run under DOS, but it does implement

pipeline tuning techniques possible with those two boards. Several new optimization features for faster scanning have been included in this release, to ensure fast scanning and the ability to detect and stop on a signal.

The Squelch Sample Rate is used to verify that signals are not being missed during scanning, and the Previous Frequency feature can be used to compensate for when a scanner may stop on a channel after the channel with the signal was detected.

The ZEIT by ARCRON RADIO-CONTROLLED CLOCK

- All World Time Zones with Precise Time
- Tell Time by the Atomic Clock that governs time for radio stations and space flights
- Sets Self By The NIST Radio Waves - WWVB Signal

-YOU'LL NEVER HAVE TO SET THE TIME AGAIN



Dealer Inquiries Invited.

Time, Hours, Minutes, Seconds
 Reception/Signal Strength
 Date or 2nd Time Zone
 BackLight Dial for Night

US and World Time
 All World Time Zones
 ARC Program Symbol
 Dual Alarm Function

Keeping Exact Time HASN'T BEEN EASIER!!

Automatically sets accurate time, date and adjusts for the start and end of daylight savings time

- Receives Radio Signal from US Atomic Clock
- Superior Signal Sensitivity (Below 20µV/m)
- Continuous Oscillator Calibration
- Internal Quartz Oscillator
- Integrated Internal Ferrite Omnidirectional Antenna
- Battery Operated with Low Battery Indicator
- High Tech Design
- Warranted
- 2.60" x 5.30" x 4.45"

ORDER YOURS DIRECT FROM ARCRON ZEIT

CALL TOLL FREE 24 HOURS **1-800-985-TIME (8463)**

630-472-9999 International

\$149⁹⁵ S&H \$4.95

M/C • VISA • DISCOVER • AMEX 2ND DAY DELIVERY AVAILABLE

CIRCLE 65 ON READER SERVICE CARD

April 1997 / POPULAR COMMUNICATIONS / 31

The software can then reverse scan back to the active channel. This feature is useful when trying to scan at very fast rates, which are less useful if they scan past a signal you want to hear.

Scancat-Gold is available from many dealers, or directly from the author at Computer Aided Technologies, P.O. Box 18285, Shreveport, LA 71138, (800) 722-6228 or <www.scancat.com>.

Select Phone USA CD

I recently tried a copy of this software which claims to have every published telephone number in the USA on its multiple CD's. Its program supports searching by name, address, city, state, and business SIC code. Once you have found a listing, you can even choose to view its neighbors, and the listings of numbers located nearby will be displayed. A mapping program was included, and listings that match your search can be exported to the mapping program, and a map generated that shows where each of the listings is located. The mapping program has state, area code, and county boundaries. The locations mapped are the center of the zip code associated with the listing. This isn't as precise as other mapping pro-

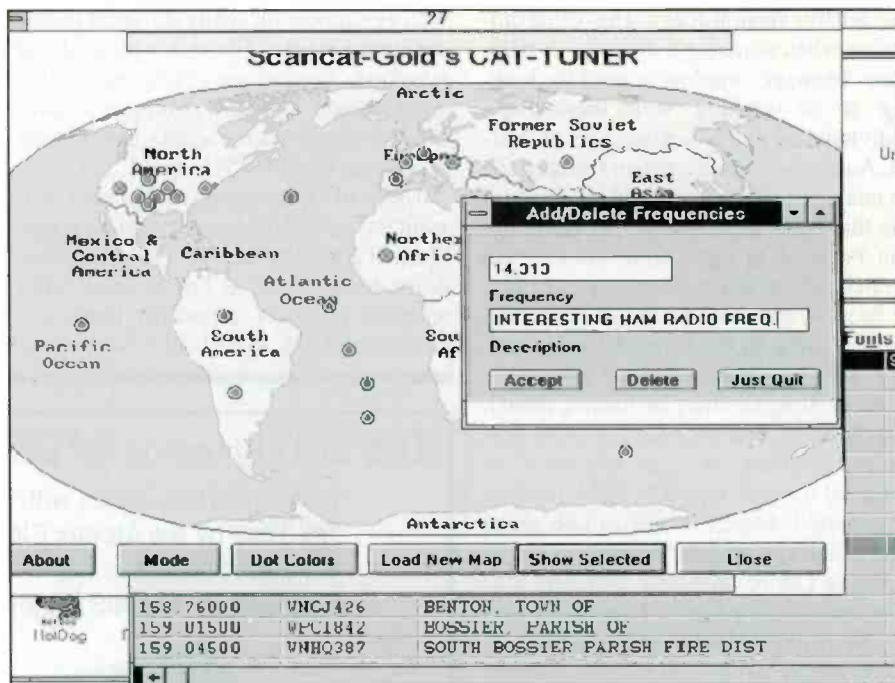

Unique "On Screen Radio" supports a "real" mouse-controllable Tuning Knob, plus Spectrum Analysis, database management, and a full complement of pop-up aids. The user moves the mouse over the spectrum analysis to see the frequency.

grams, and if you have one of those, the listings can be exported to it for more precise mapping. It was still fun to indicate all of the RadioShack stores in California

onto a state map.

There are many benefits to the monitor using this, like finding out all of the businesses located in a building with an

Pop'Comm P.O.

(from page 6)

them when they want to. The Turner Diaries describe what can happen to our society when the government comes to confiscate guns, and they just as well could be confiscating radios as well. They did this in WWII. They effectively shut down all of the ham radio operators for the duration, and in fact confiscated radios. Secondly, and more important is the fact, at least in my mind, that the ARRL is a bunch of stodgy old-timers that are still stuck in the 1930s. I equate them with the unions. They were effective in their time, but failed to change in rapidly changing times. The ARRL should have had some effect on the cellular ban, but where were they?

I don't consider myself a pessimist, however, in my opinion, the only answer to this problem is not turning to another bureaucracy, but rather a strong letter writing campaign to our Congressmen and Senators. I know they are part of the problem, but if enough people point out where the votes come from, maybe they will soon get the idea.

Dr. Pepper aka Ron Cheshire, WB6GKI
Ridgecrest, CA

Can They Ban Your Scanner?

By J.T. Ward

The first salvo in what may become a battle to ban the manufacture and sale of all scanners was fired February 5 by Thomas Wheeler, president of the Cellular Telecommunications Industry Association. Wheeler, testifying before the U.S. House Sub-Committee on Telecommunications, characterized scanner listening as "nothing less than electronic stalking," and repeatedly referred to scanner listeners as "electronic stalkers."

Wheeler went on to tell committee members that "entirely legal" scanners are "sold across the country for the purpose of listening to (cordless and cellular telephone) calls."

"This is not right," Wheeler said. "I have asked the FCC to stop the manufacture and sale of these devices," he said.

At least some committee members seemed to agree with Wheeler. Rep. Clifford Stearns (R-FL) said "cellular customers expect a certain amount of privacy and Congress has a responsibility to protect them."

Speaking on the side of scanner listeners was Bob Grove, president of Grove Enterprises. Grove said scanner owners agree that Americans deserve a reasonable expectation of privacy, but that broadcasting a clear voice into the airwaves and expecting it not to be overheard is not reasonable. The responsibility of security should not be placed on the shoulders of the scanner hobbyist, but on the service provider, he said.

"Among the estimated 10-20 million scanner owners in the United States, flagrant violations are extremely rare, certainly far fewer than among gun owners, and scanners don't kill, yet a hefty fine and lengthy jail sentence await the hapless scanner listener who merely tunes in on an anonymous telephone conversation," Grove said.

There may already be a push underway to ban scanners that receive cellular transmission images. Just before going to press, *Popular Communications* obtained a copy of a letter from FCC Chairman Reed Hundt to Rep. Thomas J. Bliley, Jr., in which Hundt assured Bliley that the FCC will "undertake a thorough examination of our current scanning device authorization and enforcement processes. In the event that we can be more rigorous and effective, we will certainly implement changes to our processes," he wrote.

You can be sure that *Popular Communications* will follow these issues closely and report in-depth on this hearing and other such attempts to restrict your rights. In the meantime, you're encouraged to contact your legislators and Mr. Wheeler at the Cellular Telecommunications Industry Association, 1250 Connecticut Avenue, NW, Suite 200, Washington, DC 20036, phone 202-736-3213, fax 202-331-8112 or e-mail him at wowcom@ctia.org.

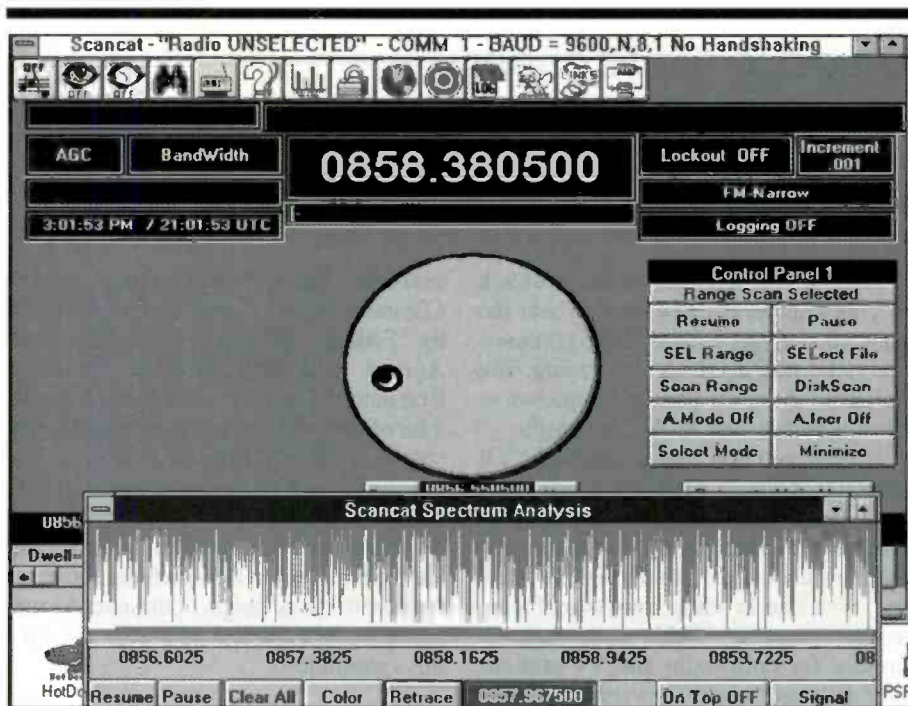

Load virtually any Windows-based "BMP" file into Scancat's Map Tuner. Program up to 500 "hot spots" on each map. Click on a "hot spot" and instantly tune your radio. Each map is a complete "visual" database. The Scancat Web Site has many free maps you can download.

antenna on the top, checking a number heard over the air for the listing, searching for a particular type of business in your area, and avoiding directory assistance charges. It's a handy resource when trying to solve a monitoring mystery.

Mailbag

Thanks to everyone who's sent letters or e-mail to Bonnie or myself. I've been asked by a couple folks, "What software do you use with your radios?" and my answer is that I've used most everything available for the PC at one time or another. There are a number of software packages undergoing review in my shack, and they will be covered in future columns. Mac fans should take note that I'm also working on reviews of software that you can use with your radios.

I've also received mail asking about what radios and computers I recommend for computer controlled scanning. I have told them that I think the RadioShack PRO-2035 which is being closed out at about \$220, and the Optoelectronics OS535 board which sells for \$200, offer a lot of value and functionality for the money when looking for a radio and interface. I'm an advocate of using computer control to collect data over long periods of time, so I like the idea of purchasing a used 386 or 486 and dedicating it to running radios in your shack. These older systems can run almost all of

the control software on the market, and don't cost as much as newer systems. HF monitors should note that the benefits of using a notebook for control in their shack is that because they use an LCD screen, they often produce much less RFI than a conventional desktop system and CRT monitor. A drawback to notebooks is that they usually don't have as many serial ports, a factor when you want to control multiple radios. Lastly, most scanning software works best when the serial port used has a 16550 UART. You can use the Microsoft Diagnostics program, MSD.EXE, which is commonly found in the DOS and/or Windows sub-directory to check a system's hardware and its communications ports.

A reader wrote to mention that when he monitors the local public safety agencies being dispatched to an address, he uses a computer based mapping program to quickly display the location. He says this enhances his monitoring. If you do something similar, or are familiar with other methods of using a computer to aid your monitoring, please drop me a line. I'd like to cover all the ways computers help us in our shacks, and not just radio interfaces or data decoders.

In the next column, we'll take a look at Deltacomm's 18500 control software for ICOM's new R8500, and other computer and radio related topics. See you in June!

Ed Griffin

UNLOCK FULL 800 MHz

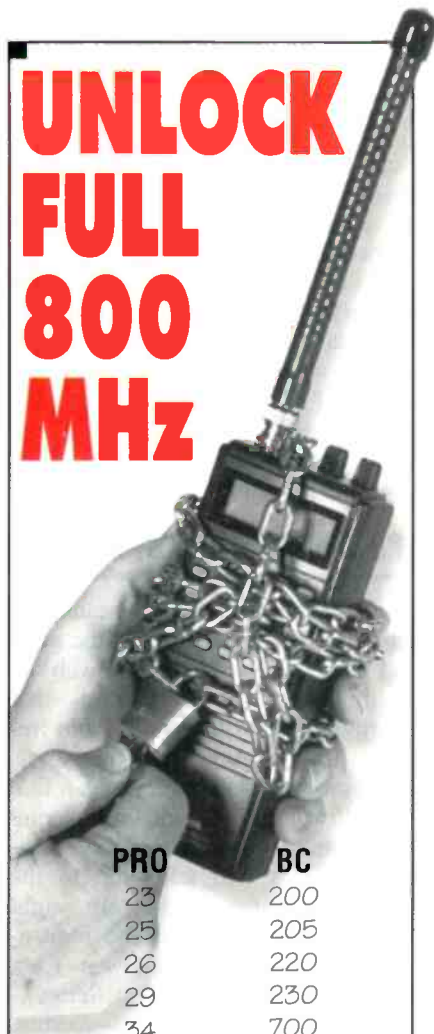

PRO	BC
23	200
25	205
26	220
29	230
34	700
37	760
39	855
43	860
46	890
51	2500
66	3000
2004	8500
2005	9000
2006	ICOM
2022	R1
2026	R100
2027	R7100
2030	AOR
2032	2700
2036	8000
2040	OPTO
2045	Xplorer
2046	

Starting at only \$40.00

Thousands of Satisfied Customers

Call for Details

508-281-8892

CELLULAR SECURITY GROUP

47 Causeway Street
Gloucester, MA 01930

Scanning radio frequencies has always been an enduring recreation for many radio enthusiasts. It's a way to keep informed about events happening in a person's locality; a way to experience the risks, the hazards and even the boredom of daily law enforcement. Many hours can go by where you only hear the routine calls of license plate investigations. It's the occasional heart-stopping calls of hot pursuit or crimes-in-action that draw many to be glued to their scanners.

Let's Get Some FAST Action!

So, how about taking your scanner to where there is always action—the racetrack! Winston Cup racing has a web site at <http://www.speedworld.net> that will provide you with tons of radio frequencies for your next trip to the races.

Once on the home page you can link to <http://www.winstoncuponline.com/frequent.html> by clicking on "Frequencies," that will take you to the Frequency Center. There are eight NASCAR links that include the frequencies for Featherlight Southwest Tour, Winston West, Winston Cup Series—Drivers, Winston Cup Series—scoring, pace car, Goodyear blimp, etc., Busch Series, Craftsman Truck Series, TV-Radio, and Busch Grand National North. There are also links to NHRA Winston Drag Racing, PPG IndyCar World Series, Indy Racing League, ASA ACDelco Challenge Series, ARCA Bondo/MarHyde SuperCar Series, and Track frequencies from around the country.

So let's see, you've just parked in the raceway lot, you have ESPN at 450.3500 or 450.2500 plugged into one channel on your scanner, the track frequency plugged into another, NASCAR pace car frequency at 463.850 in another, and have your vehicle's AM radio tuned to the local commercial radio station, which you also got from this web site. If you have all of these programmed into a handheld scanner and carry it into the stands with you, you're all set for an excellent day at the races. Let's say there's a commotion in the pits. You can enter the driver's frequency and find out that, good Heavens, they've forgotten to tighten the lug nuts during the last pit stop! That's going to cause a lot of stress for that driver until he can get back to the pits. And you'll know about it before anyone else in the stands.

"It's the occasional heart-stopping calls of hot pursuit or crimes-in-action that draw many to be glued to their scanners."

Even if you can't get to the racetrack of your choice, but still want to hear the race, you can get a list of those commercial radio stations that cover racing. The link from the home page is http://www.speedworld.net/info/radio_list.html.

Now if you don't have a radio or TV station that covers what you want to see, how about contacting them by e-mail? Don't know where to find those addresses? How about going to the Gebbie Press Inc. web site at <http://www.gebbieinc.com>. There are URL's and e-mail addresses for both radio and TV stations plus daily and weekly newspapers. Make yourself heard.

Another interesting web site for scanner fans might be KyScan at <http://www.uky.edu/~hpeach/kyscan.html>. Created by Harold Peach as a personal home page it does not represent an official unit of the University of Kentucky. Mr. Peach stated that KyScan is dedicated to the monitoring of non-broadcast, VHF or UHF radio transmissions in and around Kentucky. He has several links to other pages about NOAA Weather Radio Sites, Daniel Boone National Forest, Eastern Kentucky Flood Warning System, State Government, Military Aeronautical Routes, Ohio River Lock System and Local Information and "experts."

One link he has provided is Finding Frequencies Using Photographs. He explains that every photograph will contain some object that is commonly available, easy to get and measure. Once you have the measurement of one object in a photo, it's relatively simple to determine the dimensions of an antenna. Once the antenna dimensions are known, the next step would be to determine the antenna's resonant frequency. Peach's web page gives the easy formula to figure out that frequency. It also has a graphic to go along with the explanations.

If you see government vehicles on the road and notice their antennas, you might be interested in what frequencies they may be using. Checking out their license tag may give you a clue. One of the links from KyScan shows U.S. Government License Tags. Official license tags are preceded by a letter code designating the agency having accountability for the vehicle. A few

examples are: FC used by the Federal Communications Commission, FE used by Federal Emergency Management Agency and NRC for the Nuclear Regulatory Commission. I think if I saw a lot of any of those vehicles cruising the streets of my city, I'd start to worry.

Finally, the KyScan home page will link you to a product review of the Grove Scanner Beam antenna. This fascinating site also has some fine pictures showing the construction/design of the antenna and a graph of the SWR readings he got during a recent test.

An Email Decal For Your Vehicle?

I enjoy getting mail-order catalogs. I even enjoy getting the mail-order catalog of mail-order catalogs, because every once in a while something truly inventive shows up in them. This is the latest computer item I've encountered that has caught my eye. Everyone who signed up with an Internet provider usually sets up an e-mail address for themselves. Some have become very attached to that e-mail identification, something like a CB handle of years gone by. Now you can proudly proclaim your e-mail name to the world while you are in your vehicle. In the "Power Up!" catalog from Tiger Software they offer a personalized e-mail address decal made of high-quality vinyl to display your e-mail address on your automobile. You can get a choice of four colors: gold, silver, black, or white in either block or script fonts. It is listed for \$19.99. These custom orders are usually shipped within three days. Contact the Power Up! company at 1-800-335-4055, 24-hours, 7 days, and ask about item No. Z13-1000. As the ad copy states, "You may finally get to meet that attractive motorist you have noticed while commuting to work."

That's all for this column. Remember, if you have a favorite spot on the Internet or are interested in something I haven't covered yet, send me an e-mail message at BSZ3866@aol.com or send it to *Popular Communications* in Hicksville. Happy clicking!

Bonnie Zygmunt

Scanning The Globe

BY CHUCK GYSI, N2DUP

MONITORING THE 30 TO 900 MHz "ACTION" BANDS

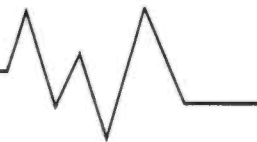

Reviewing Some Scanning Basics

For many, whether you're new to scanning or have been scanning for years, there are some issues that come up in the hobby that you need to deal with now and then. How and when should you use delay on your scanner, or how do you manage all those hundreds of frequencies in your new radio? Many hobbyists have their own ideas about these subjects, but there are some basics we all should know.

It's a good idea to see what other people think about these issues once in a while, which will give you an understanding of how things work—either for yourself, or in trying to explain things to others in the hobby.

This month we'll take a look at some of these ideas. I welcome your input on these topics and will offer your ideas, too. All you have to do is write or e-mail me and we'll pass along those ideas to the rest of the readers!

Delayed Response

A common question among scanner hobbyists is whether you should use the delay feature on your scanner. It really depends on your listening habits and whether or not your scanner has individual channel delay capability.

First, you must determine the type of delay your scanner offers. Basically, there are those that allow you to determine which channels can be selected for the delay feature, and then there are those that have delay on all the channels or none. In the latter instance, you cannot choose which channels have delay activated on them.

Realize what delay does for you: The function will hold a channel for you automatically so you don't miss a response. For instance, if your scanner stops on a certain channel to receive a transmission, normally it will resume scanning automatically as soon as the station you are hearing stops transmitting. However, in doing so, you may miss hearing the dispatcher respond to a mobile unit or vice versa. You also may miss two mobile ra-



Realistic's 400-channel PRO-2006 Scanner is considered a top-of-the-line receiver.

dios transmitting back and forth between each other, which would be especially so on a "car-to-car" channel, because the scanner would have resumed scanning while the other radio transmitted a reply.

In general, if you have a scanner that allows you to select delay for all or no channels, without individual channel selection, you'd be best using delay. There are so few instances where you would not want delay, that you'd be best to opt for the feature.

However, it is those few times where you don't want delay that individual channel selection is best. For instance, if the service you are monitoring has a repeater with a long "squellch tail" (the repeater repeating the transmission from mobile or handheld units remains on the air for a few seconds after it retransmits the signals), there is no need to use delay because the radio system you are monitoring has the feature built in for you.

How do you tell if a repeater is being used on the channel you are monitoring? First, when the mobile unit you are monitoring is done transmitting, you likely will hear a click or quick break in the squellch, which means the repeater is done relaying the signal.

Then, after a second or two, you may hear another very short burst of squellch or click, indicating the repeater is done transmitting and off the air. Most UHF radio users use repeaters at high sites to relay their mobile and handheld units over a much wider area. There are many public safety and U.S. government repeaters on VHF high band (150–174 MHz), too. If the channel in your scanner seems to be using a repeater with an adequate-length squellch tail after the mobile units are done transmitting, then you may not need the delay feature activated on those channels.

There are two exceptions: First, when the dispatch center is at the same site as the tower and repeaters are employed, there may not be a squellch tail when the dispatcher transmits. The repeater squellch tail may be present only when the mobile units transmit. Thus, you may want to leave the delay feature on these

"A common question among scanner hobbyists is whether you should use the delay feature on your scanner."

WE HAVE IT ALL! Surveillance

Infinity Transmitters
FM Wireless Transmitter Kits
Vehicle Tracking Systems
Bug Detectors
Caller I.D.
Wired Mikes
Telephone Register with Printer
Long-play Recorders
Shotgun Mikes
Telephone Recording Adapters
Alcohol Testers
Telephone Scramblers
Hidden Video Cameras
Telephone Tap Detectors
Drug Testers

MUCH, MUCH, MUCH MORE.

Our 27th Year!

Small catalog FREE.
Larger catalog send \$5.

Mail Order only. Visa, MasterCard and C.O.D. accepted for equipment only.

Inquire for dealers' prices.

A.M.C. SALES, INC.

193 Vaquero Dr. • Boulder, CO 80303
Mon.-Fri. 8 a.m.-5 p.m. Mtn. Time

800-926-2488

(303) 499-5405 • Fax (303) 494-4924

Internet: [http://www.siteleader.com/
catalogdepot/AMCSC-home.html](http://www.siteleader.com/catalogdepot/AMCSC-home.html)
E-mail: amc-sales@siteleader.com

YOU AIN'T HEARD NOTHIN' ... YET

Since 1967, CRB Research has been the world's leading publisher and supplier of unique hobby and professional books and information including:

• Scanner Freq. Guides • Military/ Federal Comm.
• Broadcast Station • Undercover
Registries • Communications
• Shortwave Freq. Guides • & Other Related Topics



Ask for
our latest
FREE
catalog.

CRB RESEARCH
P.O. Box 56, Commack, NY 11725
Ph: (516) 543-9169 FAX: (516) 543-7486
e-mail: crbbooks@aol.com

CIRCLE 11 ON READER SERVICE CARD

RAILROAD RADIO GUIDE

HEAR AND UNDERSTAND RAILROAD RADIO COMMUNICATIONS & SYSTEMS

Railroad Radio by Vincent Reh is the definitive guide to hearing and understanding railroad radio communications and systems. In 208 illustrated, perfectbound pages, you get all the information you need to monitor railroad radio and understand what you hear.

You'll learn about railroad radio history, railway operations, modern radio systems, system use, and the future of railcomms. Plus, you get numerous hints and tricks to maximize scanner performance.

Don't miss any of the action! Order your copy from your favorite dealer or direct from the publisher today. Send \$19.95 plus 3.50 shipping (7.50 outside N.A.) in USD to Byron Hill Publishing Co., PO Box 197L, Grand Isle, Vt. 05458. (802) 893-1315 e-mail rehvince@together.net

VISA/MASTERCARD ACCEPTED

CIRCLE 67 ON READER SERVICE CARD

"In searching for new frequencies, how do you tell what you are hearing?"

channels so you don't miss a mobile unit replying to the dispatcher.

The second exception would be channels that not only are used for the repeater's output frequency, but also for car-to-car communications on the same frequency as the repeater, but bypassing the repeater for short-range coverage. Leave the delay on in these instances, too.

There are a few more considerations in using delay. First, regardless of repeaters and the like, it is recommended that all local emergency services channels programmed in your scanner have the delay activated on them. Let's face it, you don't want to miss the address of a fire or shooting in your own neighborhood. However, if you also listen to outlying areas (especially for those who have scanners that can scan hundreds of channels), it's not so important that you miss a call from a fire department 50 miles away (unless, of course, you make a livelihood off of scanner listening). Also, every time your scanner sits on delay for two seconds, that time really adds up when the scanner returns to the channels you really care about most, such as your own community.

Scanners that offer 10 priority channels that can be sampled at the same time when the priority is activated, and your most important frequencies should be entered in there with delay on each.

Who's on First?

In searching for new frequencies, how do you tell what you are hearing? Is the frequency a police channel or a private security firm?

Every hobbyist needs a good frequency directory. Usually your local scanner shop carries a good guide or can recommend one that will be of help. In any event, "Police Call Plus" is available at all RadioShack stores and there is a section of the guide that can prove to be helpful. The listing shows what radio services use what frequencies and can be a first step in frequency sleuthing. You also can buy a copy of Part 90 of the FCC's rules and regulations for land mobile users to help look up frequencies, but "Police Call Plus" will provide immense help. If your scanner stops on a frequency such as

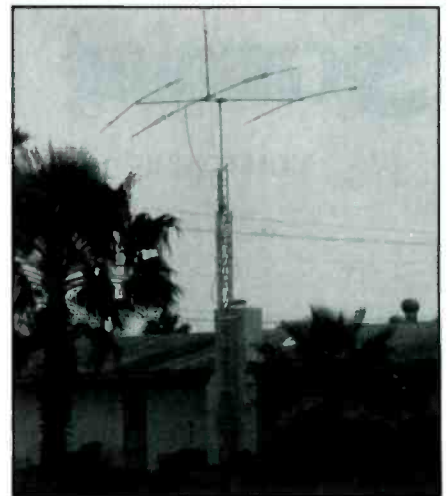

Getting your antenna up as high as possible is critical when listening to VHF/UHF communications on your scanner. Setting up your antenna and tower like this heavy-duty ham tower, is one option that will help you scan as much as possible. (Photo courtesy Aluma Tower Company, Inc.)

154.600 MHz, looking up the frequency in the chart and learn that it is a business radio service frequency that is restricted to 2 watts power output. Knowing this, you can determine that it is a walkie-talkie transmitting somewhere in your neighborhood since 2 watts only allows very short-range communications.

Frequency Management

Most scanners that hobbyists buy these days can scan hundreds of channels. However, it is important to practice good frequency management in programming these units.

Let's take a look at the popular Realistic PRO-2006, for example. The scanner has 400 channels in 10 banks of 40 channels each. If you put a different frequency in each of the 400 channels, it may take some time before the scanner returns to important frequencies you really need to hear. For instance, if you put the frequencies for your community in the first bank, then you may have a bank for railroad frequencies, another for news media, and yet others for aircraft, marine, businesses, security, etc. There are a lot of channels that your scanner may stop on before it gets back to that first important bank. Consider putting the frequencies for your local police and fire departments and more in *each* bank, or even every other bank, in your scanner. For those with PRO-2006 scanners, you may want to put your local police and fire channels

“An important rule in VHF and UHF listening is that the higher your antenna, the more you will hear.”

in channels 1–5 in bank 1, channels 41–45 in bank 2, channels 81–85 in bank 3, etc.

In a scanner I programmed for a news organization once, the most important police and fire channels for the news organization’s coverage area were programmed into the first 10 channels of each bank. That still left 30 channels per bank for other activities the news personnel needed to monitor. And by giving the scanner an opportunity to stop on the local frequencies more often, we reduced the possibility of missing an important call while the scanner was scanning many less important channels.

Antenna Height

An important rule in VHF and UHF listening is that the higher your antenna, the more you will hear. While things such as antenna gain and cable length may have a factor in the formula, it is best to get it up as high as practical. Towers aren’t cheap, but they do an excellent job in getting the antenna to where it should be. An inexpensive option would be to erect a mast and guy it sufficiently for adequate height, that is if you are putting only one or two antennas on it.

Most scanner antennas are erected on rooftops—a good place for them. However, if you live on the outskirts of a city and you want to listen primarily to services in that city, you might want to put up a directional yagi (rhymes with foggy) antenna pointed at the city to hear the bulk of the action. The yagi antenna is a directional antenna that points at its target; they also are known as beam antennas. You might even want to consider mounting a yagi antenna on a TV-type antenna rotor so you can rotate the antenna, pointing it at various cities if they are within range of your listening post. If the signals you want to hear are all around you, forget the yagis and stick with the usual omni-directional scanner antennas.

Another consideration is whether the bulk of your monitoring is on one band. If most of your listening is on VHF high band (144–174 MHz), you may want to scrap the all-band scanner antenna and

buy an antenna designed for that band. You could trot off to your local radio shop and see what professional antennas they have in stock, but you will pay “professional prices” for the privilege. You’ll make out much better heading off to the local ham radio shop and checking out a ham antenna. For instance, a 2-meter VHF ham antenna designed for 144–148 MHz will work fine in the 144–174 MHz band and a 440–450 MHz ham antenna will be perfect for 450–512 MHz monitoring. And you’ll be paying ham prices, too, not “professional” prices.

If your antenna is mounted on a five-foot mast, consider raising it on a 10-foot mast, or adding a 10-foot mast to the 15-

foot mast to get it up a bit higher. It may just make a difference in the signals you are trying to hear. But don’t use cheap coaxial cable because all that you would gain in antenna height will be lost in the cable even before the signal reaches the radio. *Spending a little bit more for better cable will pay off with better signals.*

These few tips will help you get more out of your scanner. Many of you have your own tips that you may want to pass along to fellow *Pop’Comm* readers. If you have a tip you’d like to share, send it to: Chuck Gysi, N2DUP, Scanning the Globe, *Popular Communications*, 76 N. Broadway, Hicksville, N.Y. 11801-2909, or e-mail them to <SCAN911@aol.com>.

Get online with PC on GEnie

Look for us in the Radio & Electronics Roundtable

To Join GEnie, use your computer & modem to call 1-800-638-8369.

At the U# prompt, type JOINGENIE

And for a special introductory offer, At the key/offer code prompt, type MEG528

CIRCLE 71 ON READER SERVICE CARD

C. CRANE COMPANY

COMMUNICATION EXCITEMENT

The Sangean ATS 909

- Shortwave
- Scanners
- Antennas

•Sangean •Grundig •Drake •Uniden

The most powerful loop antennas for shortwave / MW and much more!

558-10TH ST. FORTUNA CA 95540

Free Catalog FAX 707-725-9060

800-522-(TUNE) 8863

CIRCLE 68 ON READER SERVICE CARD

READER SERVICE CARD

Use Your Free Reader Service Card For More Information On Companies Advertising In This Issue.

Motron 310 Garfield St Suite 4
PO Box 2748
Eugene, Oregon 97402
<http://www.motron.com>

DTMF & ROTARY TEST DECODERS

TONE-MASTER™ TM-16A & TM-16A Plus

Decode and display DTMF from nearly any audio source; scanner, tape recorder, etc. And now decode and display either DTMF or Rotary digits from a telephone. **TM-16A PLUS** with RS-232 serial output includes Logger Software for optional automatic date/time/number logging using your IBM Compatible computer. Price and specifications subject to change without notice.

TM-16A DTMF & Rotary Decoder \$179.00 **TM-16A Plus with RS-232 output \$249.00**

S/H: \$8 USA, \$11 Canada, \$16 Foreign. Premium shipping available for an additional charge. Visa, MasterCard, Discover & American Express Accepted. COD on Cash or Money Order basis only: \$5.

Orders: (800) 338-9058 Info: (541) 687-2118 Fax: (541) 687-2492

Clandestine Communique

TUNING IN TO ANTI-GOVERNMENT RADIO

La Voz del CID Financial Problems

We open this month with news that La Voz del Cuba Independiente y Democrática (La Voz del CID) is having financial problems and may have to go off the air or, indeed, may have done so by now. Huber Matos, who is el jefe at the CID organization says some of the large donations it received in the past from the governments of various countries in Latin America are no longer forthcoming. He says that no aid comes from the U.S. government. You can check **9941** and **6305** to see if CID is still hanging in there. The transmitter is said to be 50 kW.

A new clandestine is the **Voice of Azerbaijan**, broadcasting in Azeri on **6055** between 1630 and 1730, claiming to support unity for north and south of Azerbaijan. It apparently opposes the governments of both Armenia and Iran. Like so many of the clandestine stations in this area, the broadcast time-frequency pairings don't offer a lot of hope for being received in most of North America.

The **Voice of the Worker**, which supports the Iranian Revolutionary Worker's Party and opposes the government of Iran is now scheduled from 1530 to 1615 and 1730 to 1815 on **3930** and **4200**, both frequencies variable.

The **Voice of the Mojahed** is using **5140** and **9430** (variable) between 1900 and 2100.

Radio of Islam—the **Voice of the Islamic Movement in Iraqi Kurdistan** is active between 1700 and 1800 on **4135**, **4400** and **6305**, all variable.

The Voice of Iraqi Kurdistan has a U.S. contact address: P.O. Box 2443, Merrifield, VA 22116. They also have an address in England: KDP-Europe, P.O. Box 1504, London W7 3LX, England.

The **Voice of Tibet**, carried via the Far East Broadcasting Association's transmitters in the **Seychelles Islands** continues to flip flop between **15480** and **15445** for the Tibetan broadcast which runs from 1145 (or a couple of minutes earlier) to 1200 (or earlier).

Radio Miami International is now carrying a Khmer-related program—Thansour Thmey Radio, produced by the Khmer Community Rescue Association of Seattle, Washington. This airs Saturdays from 2200 to 2300 on **9955**. The first half hour is in Khmer, the second half hour—termed the "Voice of Cambodia Radio International," is in English. This English segment is intended to promote Cambodian culture to a general audience. You can write to them at: 1611 Southwest Roxbury St., Seattle, WA 98106.

The **Voice of Palestine Islamic Revolution** airs in Arabic over an Iraqi transmitter on **11745** at 1200.

The U.S. government-run **Radio Free Asia** has reportedly had to give up broadcasting via transmitters in Kazakhstan and Tajikistan, after China let the governments of those two countries know how displeased it was over their carrying the broadcasts. One station which may carry the broadcasts in the future is KHBN, Palau. Radio Free Asia has now added broadcasts in Tibetan.

Radio Kuridat Nigeria, the **Voice of Democracy** is currently scheduled on **6205** from 1905 to 2005.

The **Voice of Sudan**, which opposes the current Sudanese



*La Voz del CID may be winding down its operation due to lack of funds.
(Thanks to Arnold Faabri for this 1988 CID QSL.)*

government, is now also using **12008**, in parallel with **8000** and **9025** around 0400 to 0600. The 12008 frequency may not propagate very well to North America at that hour, except in the summer.

The forever mysterious **New Star Broadcasting** station—which some experts say broadcasts from the Chinese mainland and others believe is in Taiwan, continues to be reported on occasion in North America, after a very long time during which there seemed to be no loggings of this at all. **8300** appears to be the most widely heard frequency, perhaps because a signal is more easily spotted there than on **9275** and **11430**, two channels the station uses or has used in the past. The station doesn't seem to adhere to any specific schedule, but is active anywhere during the period from around 0900 to 1600 or 1700. The 1200 to 1400 period offers the best chance for North American listeners to pick this one up. The broadcasts are short, lasting only a few minutes, and consists of number groups in Chinese and some Chinese music. It seems to be some sort of government-run "spy" transmitter though, again, no one has definite proof as to which China it belongs to. Needless to say, the New Star Broadcasting Station has never been QSL'd!

Once the arrangements are finalized, the one-time clandestine **Voice of the Resistance of the Black Cockerel** is to be sold to a private company. The station, which goes by the acronym VORGAN, was for years, the radio mouthpiece for Jonas Savimbi's UNITA party in Angola. It has been sort of semi-legit for some time now. The new owner will be the Polytechnic Academy, based in Luanda. Once the new owners take over the station's name will be changed to Radio Despertar (or, "Wake Up Radio"). Once that happens the last of VORGAN's clandestine flavor will be gone. It is still active on **7100**, **9700** and **11830**.

Clandestine expert Mathias Kropf has issued his annual survey of worldwide clandestine broadcasting activity. He notes that clandestine activity dropped by five percent last year, but that transmissions to Asian targets increased slightly (less than one percent). The number of active target areas also increased last year. Two of the areas which receive the most attention from clandestine broadcasters are Iraq and Cuba.

That does it for this time. We're always interested in receiving your clandestine station logs, as well as QSL news, information from and about clandestine stations or the groups which sponsor them. Thanks for your continued interest! ■

Pop'Comm's World Band Tuning Tips

April 1997

This listing is designed to help you hear more shortwave broadcasting stations. The list includes a variety of stations including international broadcasters beaming programs to North America, others to other parts of the world, as well as local and regional shortwave stations. Many of the transmissions listed here are not in English. Your ability to receive these stations will depend on time of day, time of year, your geographic location, highly variable propagation conditions and the receiving equipment used.

AA, FF, SS, GG, etc. are abbreviations for languages (Arabic, French, Spanish, German). Times given are in UTC, which is five hours ahead of EST, i.e. 0000 UT equals 7 p.m. EST, 6 p.m. CST, 4 p.m. PST.

UTC	Freq.	Station/Country	Notes	UTC	Freq.	Station/Country	Notes
0330	7110	Radio Ethiopia	Amharic	0200	6895	Radio Sensacion, Peru	SS
0000	4960	Radio Federacion, Ecuador	SS/local	0200	9475	R. Cairo, Egypt	
0000	5995	Voice of America		0200	9735	R. Nacional Paraguay	SS
0000	7150	Radio Ukraine		0200	11710	RAE, Argentina	
0000	9705	R. Mexico Int'l	SS	0230	6200	Radio Sweden	
0030	4980	Ecos del Torbes, Venezuela	SS	0230	7160	Radio Tirana, Albania	
0030	5965	R. Havana Cuba	SS	0230	9655	Radio Austria Int'l	
0030	7325	Austria Radio Int'l		0243	7215	Qatar Broadcasting Service	AA, s/on
0030	9540	Radio Exterior Espana, Spain		0250	6095	Vatican Radio	
0050	11800	RAI, Italy		0250	7200	Republic of Sudan Radio	AA
0100	4805	Radiodifusora Amazonas, Brazil	PP	0300	3220	Channel Africa, South Africa	
0100	4875	Rdf. Roraima, Brazil	PP	0300	3306	Zimbabwe Broadcasting Corp.	
0100	4885	Radio Clube do Para, Brazil	PP	0300	4919	R. Quito, Ecuador	SS
0100	6135	Swiss Radio Int'l		0300	4935	Radio Tropical, Peru	SS
0100	6190	Radio Budapest, Hungary		0300	4940	Radio Amazonas, Venezuela	SS
0100	7250	V of Vietnam, via Russia		0300	4955	Radio Nacional, Colombia	SS
0100	7305	Slovak Radio, Slovakia		0300	7115	R. Sweden	
0100	7345	R. Prague, Czech Republic	EE	0300	9640	Radio Botswana	EE/local
0100	9545	Deutsche Welle, Germany		0300	9690	China Radio International, via Spain	
0100	9560	R. Norway	EE Sun	0300	9700	Radio Bulgaria	
0100	9745	HCJB, Ecuador		0330	4461	Radio Norandina, Peru	SS
0100	9835	Radio Budapest, Hungary		0330	4760	Trans World Radio, Swaziland	GG
0100	11785	Radio Guiaba, Brazil	PP	0400	3200	Trans World Radio, Swaziland	
0100	15167	Radio Tahiti	FF	0400	3995	Deutsche Welle, Germany	GG
0130	5890	Radio Mi, Honduras	SS	0400	5975	BBC via Antigua	
0130	5960	R. Japan, via Canada		0400	6075	CFRX relay CFRB, Canada	
0130	5981	AWR/Union Radio, Guatemala	SS	0400	9590	BBC, England	
0130	7290	Radio Sweden		0400	9790	Radio France International	FF
0130	7448	Voice of Greece	GG/EE	0430	4770	R. Nigeria, Kaduna	sign on
0200	3250	Radio Luz y Vida, Honduras	SS	0500	4850	CRTV, Yaounde, Cameroon	FF/EE
0200	4985	Radio Brazil Central, Brazil	PP	0500	4904.5	Radiodiffusion Nat'l Tchadienne, Chad	FF
0200	5030	Adventist World Radio, Costa Rica	SS	0500	4990	Radio Nigeria, Lagos	
0200	5050	R. Jesus del Gran Poder, Ecuador	SS	0500	6055	Radio Exterior Espana, Spain	
0200	5077	Caracol Colombia	SS	0500	6105	Radio Universidad, Costa Rica	SS
0200	5905	Radio Budapest, Hungary		0500	6110	Radio Japan	EE
0200	5950	Voice of Free China via USA		0500	6185	R. Educacion, Mexico	SS/EE
0200	6000	Radio Havana Cuba	EE	0500	7480	R. Bulgaria	
0200	6025	Radio Amancer, Dominican Rep.	SS	0500	9580	Africa No. One, Gabon	FF
0200	6045	Deutsche Welle, Germany		0500	9675	Channel Africa, South Africa	
0200	6150	Adventist World Radio, Costa Rica	SS				

UTC	Freq.	Station/Country	Notes	UTC	Freq.	Station/Country	Notes
0530	4750	CRTV, Bertoua, Cameroon	FF	1330	13770	Radio Austria Int'l	
0530	5034	R. Centrafrique, Central Afr. Rep.	FF	1400	11720	R. Norway	NN
0600	4815	RadioTV Burkina, Burkina Faso	FF	1400	13580	Radio Prague, Czech Republic	
0600	4870	ORTB, Benin	FF	1400	13685	Radio Vlaanderen Int'l, Belgium	
0600	6090	Caribbean Beacon, Anguilla	EE	1400	17780	RAI, Italy	II
0600	6150	RDP International, Portugal	PP	1400	17830	Qatar Broadcasting Service	AA
0600	6165	Swiss Radio Int'l		1430	9535	Radio Japan NHK World	
0600	9425	Voice of Greece		1430	12080	Radio Australia	
0630	6015	R. Austria Int'l, via Canada		1430	15615	Kol Israel	FF
0630	7180	Radio Denmark, via Norway	DD	1430	21515	Radio Portugal Int'l	
0700	4783	Radio TV Maliene, Mali	FF	1500	11890	Radio Oman	AA
0700	7155	RTV Malagasy	FF	1500	13635	Swiss Radio Int'l	
0700	11615	HCJB, Ecuador		1500	15120	Voice of Nigeria	local lang.
0730	5985	Radio Vlaanderen Int'l, Belgium		1500	17545	Reshet Bet, Israel	Hebrew
0800	3945	Radio Tampa, Japan	JJ	1600	11690	Radio Jordan	
0800	6100	R. New Zealand Int'l		1600	21560	Deutsche Welle, Germany	GG
0800	7115	Trans World Radio, Monaco		1630	15395	UAE Radio, Dubai	EE
0800	9445	HCJB, Ecuador	EE	1630	21700	R. Japan NHK World, via Gabon	JJ
0900	3290	Guyana Broadcasting Corp.		1700	15300	Radio France International	FF
0900	4991	Radio Ancash, Peru	SS	1700	15715	WINB, Pennsylvania	
0930	4895	Radio Bare, Brazil	PP	1700	15205	VOA via Morocco C203	
0930	9665	Radio Marumby, Brazil	PP	1730	11970	R. Jordan	AA
1000	3260	Radio Madang, Papua New Guinea	Pidgin	1800	11775	Caribbean Beacon, Anguilla	
1000	3375	Radio Educadora, Brazil	PP	1800	11975	VOA relay, Sao Tome	
1000	6010	Radio Mil, Mexico	SS	1800	15160	Radio Algiers Int'l, Algeria	
1000	6035	La Voz de Guaviare, Colombia	SS	1800	15244	Voix du Zaire	FF
1000	6106	CKZN, Canada		1800	15265	Radiobras/Radio Nacional, Brazil	
1000	9505	Radio Tacna, Peru	SS	1800	15450	RTT Tunisia	AA
1000	21605	UAE Radio, Dubai		1830	11645	Voice of Greece	
1100	3380	Radio Chortis, Guatemala	SS/local	1830	11705	Radio France International	FF
1100	4770	Radio Centinela del Sur, Ecuador	SS	1830	11850	Voice of the Great Homeland, Libya	AA
1100	4890	NBC, Papua New Guinea	Pidgin	1830	11990	Radio Kuwait	
1100	5290	Krasnoyarsk Radio, Russia	RR	1900	15345	RAE, Argentina	
1100	6175	Faro del Caribe, Costa Rica	SS	1900	15540	HCJB, Ecuador	
1100	9580	R. Australia		1900	17785	VOA via Morocco	
1130	6120	R. Japan via Canada		1930	11734	Radio Tanzania, Zanzibar	Swahili
1130	9650	R. Korea, S. Korea, via Canada		1930	15505	Radio Kuwait	AA
1130	9700	Radio New Zealand Int'l		2000	12085	Radio Damascus, Syria	
1200	4840	Heilongjiang PBS, Manchuria, China	CC	2100	9550	R. Havana Cuba	
1200	9510	R. Australia		2100	9910	All India Radio	
1200	13790	R. Bulgaria		2100	9935	RS Makedonias, Greece	Greek
1200	13800	Radio Norway		2100	13725	Radio Havana Cuba	USB mode
1200	15400	R. Finland Int'l	Finnish	2130	7430	RS Makedonias, Greece	Greek
1230	9370	KSDA, Guam	CC	2130	15415	R. Jamahiriya, Libya	AA
1230	9840	Voice of Vietnam		2200	9200	Republic of Sudan Radio	AA
1230	11900	Radio Finland Int'l		2200	9445	Voice of Turkey	TT/EE
1230	12020	Voice of Vietnam		2200	9570	R. Portugal	PP
1230	12085	R. Ulaan Bataar, Mongolia		2200	11585	Kol Israel	Hebrew
1230	13610	R. Vlaanderen Int'l, Belgium		2200	17795	Radio Australia	
1230	17630	Africa No. One, Gabon		2230	5945	Radio Austria Int'l	
1300	7145	Radio Thailand	various	2230	6090	Radio Nigeria, Kaduna	Hausa
1300	7405	China Radio International		2230	9430	Radio Prague, Czech Republic	
1300	9590	R. Norway	NN	2230	9855	Radio Kuwait	AA
1300	9625	CBC Northern Service, Canada		2230	11600	R. Prague, Czech Republic	
1300	11940	Radio Romania Int'l		2300	5100	Radio Liberia	EE/FF
1300	15084	Voice of the Islamic Rep. of Iran	Farsi	2300	7475	RRTV Tunisienne, Tunisia	AA
1300	17745	R. Romania Int'l		2300	9900	Radio Cairo, Egypt	
1320	21520	RAI, Italy	s/on; Sun.	2300	11700	Radio Pyongyang, North Korea	
1330	9715	Radio Tashkent, Uzbekistan		2330	7105	Radio Romania Int'l	
1330	9830	Radio Sweden		2330	7125	Voice of Russia	
1330	11650	R. Sweden		2330	7215	RTVI, Cote D'Ivoire (Ivory Coast)	FF
1330	11785	Broadcasting Svc of Kingdom of Saudi Arabia	AA	2330	9485	Radio Denmark, via Norway	
				2355	9925	R. Vlaanderen Int'l, Belgium	GG

Product Parade

BY NANCY BARRY

REVIEW OF NEW, INTERESTING AND USEFUL PRODUCTS

On-Site Paging Systems

Inter Page LP offers on-site paging systems designed to allow businesses to silently transmit messages to individual employees or employee groups. **Connexions** is a local area on-site paging system that eliminates overhead paging by operating through any standard telephone or IBM-compatible PC. Connexions sends numeric messages or pre-programmed alpha messages via the telephone, or custom alpha messages up to 240 characters using a desktop PC. Connexions also interfaces with existing alarm panels and monitors a variety of events including fire, security and access control. The pagers require 12 Vdc, 30 mA standby, 300 mA and transmit on 457.550 MHz, FM, 512 baud. The transmitter measures 7.5 x 13.18 x 2.95 (WHD) inches (without 1/4 wave antenna).

The **Dat-A-Base Nurse Call UHF** in-

formation system, notifies staff of urgent situations automatically. Emergencies may be reported at the touch of a button through call points activated from within a resident's room. When a resident requires assistance, the resident signals for help by the use of a nurse calling button. The **Dat-A-Base Nurse Call UHF** system contacts assigned staff members instantly through alphanumeric paging. The call is logged and must be cancelled at the origin of call when the call is attended. If not canceled, the call upgrades to include other members of staff until the assistance call is addressed. If the attending staff determines additional assistance is needed, they can summon additional personnel for an emergency call on the call point. The **Dat-A-Base Nurse Call UHF** can also monitor fire doors, telephones and front doors, as well as monitor response time and reschedule calls during shift changes

or low staff times. The base station requires no operator and can operate 24-hours a day. The unit has a keyboard which can be removed from the console when not in use. The System includes central receiving station with two-line, 40-character LCD display, receiver, real time clock, serial printer port, UHF alphanumeric paging system, keyboard, battery back-up, PSU and database software and is available for \$3,795. Accessories and add-ons are also available.

On-site paging systems by Inter Page allow LAN users to send alphanumeric messages to radio pagers using third party software by LANsource and Windows-interfaced paging software. Workstation users can send detailed custom messages instantly over dedicated and non-dedicated networks on Windows NT, Windows 95 and WFW 3.11 platforms. Any PC can use the WinPage paging software and com port sharing technology to send messages to the

DEDICATED TO THE SCANNING AND SHORTWAVE ENTHUSIAST. WE'RE MORE THAN JUST SOFTWARE!

NEW!

COPYCAT-PRO

IMPROVED!

The ONLY Commercially Available Computer Control Program for the Universal M-7000 & M-8000. AEA's PK-232 and the MFJ-1278 ... **... JUST GOT BETTER!**



STANDARD COPYCAT FEATURES

- 32K incoming text buffer
- Pull down menus
- Mouse support (but not required)
- 20+ programmable macros
- Runs on any 640K PC Compatible
- 50 page printed manual
- New Improved online help

Note: Std. COPYCAT Does Not Support Radio Interface

NEW COPYCAT-PRO FEATURES

- Control BOTH your TNC and radio simultaneously! Send commands to TNC and at same time, send frequency and mode to radio!
- NEW! Multiple pop-up windows for HELP, frequency files, and text editor. Instantly go between any of three windows with single keystrokes.
- Supports ALL SCANCAT frequency file formats, or create your own!
- NEW, easier, "Plain English" MACRO language for control of all radio and TNC functions.
- RADIO SUPPORT for most AOR, JRC, KENWOOD, ICOM, YAESU, plus LOWE's HF-150 and Watkins Johnson's HF-1000.

Discover our revolutionary COMPUTER CONTROL PROGRAM for the M-7000 and M-8000. Let COPYCAT free you FOREVER from remembering all those buttons and keys. COPYCAT does it all! Simple "PULL-DOWN" menu control all functions. No more looking through complicated manuals or searching for buttons. ALL commands are in plain English. "PLUS" COPYCAT has a fully editable text buffer, with cut & paste. Save/load/edit/print files. PROGRAMMABLE macros and much more. COPYCAT supports ALL the above units within ONE program. Simply select your units from COPYCAT's EASY-TO-USE menu and GO!

COPYCAT-PRO \$79.95, COPYCAT (std) \$59.95

upgrades to COPYCAT-PRO \$24.95 S/H \$5.00 (\$7.50 Foreign)

(If you don't have the specially wired cable for the M-7000/8000, be sure to order our serial adapter @ \$24.95)

HOKA CODE-3 USA Version

"The Standard Against Which All Future Decoders Will Be Compared"

Many radio amateurs and SWLs are puzzled! Just what are all those strange signals you can hear but not identify on the Short Wave Bands? A few of them such as CW, RTTY, Packet and Amtor you'll know - but what about the many other signals?

There are some well known CW/RTTY Decoders but then there is CODE-3. It's up to you to make the choice, but it will be easy once you see CODE-3. CODE-3 has an exclusive auto-classification module that tells YOU what you're listening to AND automatically sets you up to start decoding. No other decoder can do this on ALL the modes listed below - and most more expensive decoders have no means of identifying ANY received signals! Why spend more money for other decoders with FEWER features? CODE-3 works on any IBM-compatible computer with MS-DOS with at least 640kb of RAM, and a CGA monitor. CODE-3 includes software, a complete audio to digital FSK converter with built-in 115V ac power supply, and a RS-232 cable, ready to use. CODE-3 is the most sophisticated decoder available for ANY amount of money.

26 Modes included in STANDARD package include:

- Morse *
- RTTY/Baudot/Murray *
- Sitor CCIR 625/476-4
- ARQ - Navtex *
- AX25 Packet *
- Facsimile all RPM (up to 16 gray shades at 1024 x 768 pixels *
- Autospec - Mk's I and II
- DUP-ARQ Artrac
- Twinplex
- ASCII *
- ARQ6-90/98
- SI-ARQ/ARQ-S
- SWED-ARQ-ARQ-SWE
- ARQ-E/ARQ1000 Duplex
- ARQ-N-ARQ1000 Duplex Variant
- ARQ-E3-CCIR519 Variant
- POL-ARQ 100 Baud Duplex ARQ
- TDM242/ARQ-M2/4-242

- TDM342/ARQ-M2/4
- FEC-A FEC100A/FEC101
- FEC-S * FEC1000 Simplex
- Sports Info 300 baud ASCII
- Hellsreiber-Synch/Asynch *
- Sitor * RAW (Normal Sitor but without Synch.
- ARQ6-70
- Baudot F788N
- Pactor *
- WEFAX *

EXTRA OPTIONS

- REG. PRICE
- Piccolo \$85.00
- Coquelet \$85.00
- 4 special ARQ & FEC systems:
- TORG-10/11
- ROU-FEC/ RUM-FEC.
- HC-ARQ (ICRC) and
- HNG-FEC \$115.00
- SYNOP decoder \$85.00

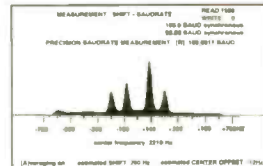

Simulated Speed Measurement Module

STANDARD CODE-3 DECODER

\$595.00 + S & H

Includes: ALL Modes, Plus Oscilloscope*, ASCII Storage, Auto Classify*, and PACTOR* Options

with ALL EXTRA OPTIONS \$795.00 + S & H

CODE 3 - GOLD VHF/SW DECODER

\$425.00 + S & H

Includes POCSAG & ACARS Plus * Modes/Options

with ALL EXTRA MODES/OPTIONS \$595.00 + S & H

ALSO AVAILABLE - HOKA CODE-30 DSP-based Professional Decoder - CALL FOR PRICE

INTERNET WEB ADDRESS - <http://www.scancat.com> WEB E-MAIL - scancat@scancat.com

(S & H \$10 US, \$15 Foreign)

Order direct or contact your favorite dealer

COMPUTER AIDED TECHNOLOGIES P.O. Box 18285 Shreveport, LA 71138

Phone: (318) 687-4444 FAX: (318) 686-0449

FREE DEMO ON BBS & WWW

Live Tech Support (318) 687-2555 (9 am - 1 pm Central M-F) Nitetime BBS (SCANCAT File Area) (318) 631-3082 (7 pm - 6 am Cent)

Orders Only
888-SCANCAT
888-722-6228

customer-owned transmitter. The network software for the Connexions system has a suggested list price of \$199.00.

For more information, contact Inter Page LP, 618 N US Highway One #200, North Palm Beach, FL 33408; phone 407-844-7900; 800-992-1000; fax 407-844-5844.

Geoworks and Puma Alliance Enhances Mobile Communications

Geoworks, developer of GEOS® operating system software, and Puma Technology, one of the industry's leading suppliers of mobile data exchange, wireless infrared (IR) connectivity and content-aware data synchronization solutions, have announced an alliance to build unique connectivity solutions for GEOS-based smart phones and organizer devices. The companies will share technology in order to develop data synchronization solutions between desktop PCs and emerging, high-end mobile communicating devices such as the Nokia 9000 Communicator. Both companies plan to propose a series of standard data-exchange formats to ease data

sharing and synchronization. The first proposed standard will be electronic data exchange software enabling users to create, exchange and store personal information in a unique electronic format. The solution will allow users to transfer information over wireless IR, serial and parallel cable, and across e-mail connections.

Geoworks develops and markets the GEOS operating system and application software for the emerging Consumer Computing Devices (CCD) market. The company is focused on enabling the development of smart phones and electronic organizers. For more information about Geoworks and the GEOS operating system, contact Geoworks on the Web at <<http://www.geoworks.com>>.

Puma Technology is a provider of mobile data exchange software, high-performance wireless infrared connectivity solutions that allow users to exchange or access information and applications from a remote computer over both wireless and wired media, and content-aware data synchronization software for PCs and handheld devices. For more information about the company or their products, contact them at their World Wide Web site at <www.pumatech.com>.

New Galaxis Future 1 Planar Satellite Antenna

The Future 1 is a satellite antenna designed to simplify and enhance satellite and microwave reception. The Future 1 can receive over 100 television and radio stations like most satellite systems available, however, the antenna's flat, compact design makes for easier and more inconspicuous mounting. This unit can receive both analog and digital satellite stations and measures 15.5 x 8.5 x 1.5 inches. The Future 1 is also weatherproof, making it convenient for both home and mobile installations. This, and other satellite systems, will be available from Galaxis USA in spring of 1997.

For further information, contact Galaxis USA, Ltd., 30 Nassau Street, 4th Floor, Princeton, NJ 08542; phone 609-924-1001; fax 609-924-4442.

Correction

In last month's "Product Parade" on page 42, the new product announcement for Cherokee's 6-meter radio listed the incorrect phone number. The correct number is 847-839-0015.

DEDICATED TO THE SCANNING AND SHORTWAVE ENTHUSIAST, WE'RE MORE THAN JUST SOFTWARE!



INTRODUCING . . . SCANCAT GOLD for Windows

Since 1989, The Recognized Leader in Computer Control

Once you use SCANCAT with YOUR radio, you'll NEVER use your radio again WITHOUT SCANCAT!

SCANCAT supports almost ALL computer controlled radios by: AOR, DRAKE, KENWOOD, ICOM, YAESU and JRC (NRD) Plus PRO-2005/6/35/42 (with OS456/535), Lowe HF-150, and Watkins-Johnson.

SCANCAT'S BASIC FEATURES

- Search between any 2 frequencies.
- Search by ANY increment.
- Create Disk files.
- Import from most text formats to a working SCANCAT file.
- Unattended Logging of frequencies to files while scanning.
- Scan Disk Files.
- Spectrum Analysis to Screen OR Printer.
- Supports PerCon & Mr. Scanner CD Roms.

PLUS

- LINK up to 15 Disk files.
- Scan VHF & HF Icom's Simultaneously.
- Print to ANY printer or Disk files.
- MULTIPLE search filters for Diskfile Scanning.
- Search by CTCSS & DCS tones with OS456/535 or DC440 (ICOM only).
- INCLUDES several large shortwave and VHF/UHF databases

NEW!
Windows Version
Supports AR5000
and IC-R8500

- Demographic search for frequency co-ordination and 2-way Usage Analysis.
- Detailed logging to ASCII type files with DATE, TIME, Sig Str, Air Time.
- UNLIMITED file sizes with our exclusive SCANCAT filing method.
- Exclusive "MACRO" control by frequency of Dwell, Hang, Resume, Sig, Threshold and even 6 separate programmable, audible alarms.
- Command line options for TIMED ON/OFF (Unattended) logging/searches.

Fully Restorable
AR2700 & AR5000
These Units Are
FULL-800MHz
Restorable

SCANCAT IS NOT COPY PROTECTED —USE ON AS MANY COMPUTERS AS YOU NEED • SCANCAT (DOS) will run on virtually ANY 640K computer, EVEN HP-100XLT PALMTOP!

EXCLUSIVE WINDOWS FEATURES

All the features you EXPECT from a true Windows application such as:

- NO MORE CONVERSION! DIRECT scanning of most DBASE, FOXPRO, ACCESS, BTRIEVE files WITHOUT "importing". Our Exclusive "AUTO-PLAN" even sets the mode and increment on the fly!
- UNIQUE database management system with moveable columns. Even SPLIT columns into doubles or triples for easy viewing of ALL important data on one screen.
- VERSATILE "Functional" spectrum analysis. NOT just a "pretty face". Spectrum is held in memory for long term accumulation. Simply "mouse over" to read frequency of spectrum location. "CLICK" to immediately tune your receiver. You can even accumulate a spectrum from scanning DISKFILES of random frequencies!
- Exclusive "SLIDE RULE" tuner. Click or "skate" your mouse over our Slide-Tuner to change frequencies effortlessly! OR use our graphical tuning knob.
- INTERACTIVELY have database, MAPS or Scanning functions on screen simultaneously.
- MAPS - Load virtually ANY map or GRAPHIC image in "BMP" format (several included with ScanCAT). Program "hot spots" with your favorite frequencies. Up to 1000 frequencies per map. Click on Hotspot to immediately tune your receiver.
- A Complete Modem/Terminal with support for most current modems. Full X-Y-Zmodem download upload support up to 28,800.

SCANCAT GOLD FOR DOS.....\$94.95 + S & H* SCANCAT GOLD FOR WINDOWS.....\$99.95 + S & H* UPGRADE from any version.....\$29.95 + S & H* *\$5 U.S. \$7.50 FOREIGN

CAT-WHISKER

TIRED OF YOUR HANDHELD SCANNER ALWAYS FALLING OVER JUST TO KEEP THE ANTENNA "VERTICAL"?



Try our unique, swivel base, telescopic scanner antenna. Our new CAT-WHISKER lets you lay your handheld scanner on its back and still keep the antenna vertical!

- Swivels to ANY angle
 - Easily adjusts to any length AND frequency
 - Fits ANY scanner with a BNC antenna connector
 - Fits on BACK or TOP mount scanner antenna inputs
- CAT-WHISKER #1 (5 to 23 Inches) **\$19.95**
CAT-WHISKER #2 (6 to 36 Inches) **\$24.95**
(plus \$2.50 S & H)

"UNI-VERSATE" INTERFACE

- Supports ICOM, AR8000/2700, YAESU and SCOUT-40.
- Comes with 6 FOOT cable, and adapters to fit all units within a single package (Must Specify Yaesu)
- Unlike "single radio" adapters, can be used with ANY radio supported, simply change the adapter, then "Plug and Play."
- Expandable in future with a simple add on adapter.
- No external power required. Draws power from computer.
- "Reaction Tune" scout with NO modifications to radio.

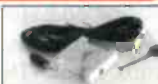

NOW IN STOCK

CAT-232C "UNIVERSATE INTERFACE".....\$99.95 + s & h

DEALER INQUIRIES INVITED

INTERNET WEB ADDRESS - <http://www.scancat.com> WEB E-MAIL - scancat@scancat.com

Order direct or contact your favorite dealer

COMPUTER AIDED TECHNOLOGIES P.O. Box 18285 Shreveport, LA 71138

Phone: (318) 687-4444 FAX: (318) 686-0449

FREE DEMO ON BBS & WWW

Live Tech Support (318) 687-2555 (9 am - 1 pm Central M-F) NiteTime BBS (SCANCAT File Area) (318) 631-3082 (7 pm - 6 am Cent)

Orders Only
888-SCANCAT
888-722-6228

The Listening Post

WHAT'S HAPPENING: INTERNATIONAL SHORTWAVE BROADCASTING BANDS

Central America Shortwave Activity!

At long last, the University Network's Caribbean Beacon has begun regular broadcasts on shortwave from Anguilla in the Leeward group. Check **6090** during the evenings and **11775** during the daytime for the Caribbean Beacon's broadcasts, devoted exclusively to the preaching of Dr. Gene Scott. Dr. Scott is on the air over a number of shortwave outlets, so don't just assume that if you have him you have Anguilla. The Caribbean Beacon uses only **6090** and **11775**. The transmitter is 100 kW, although initially it was operating at around 80 kW.

There is some fresh shortwave activity in Central America, too. In Honduras, a station calling itself **Radio MI** has begun transmitting on **5890** and identifying as "HRMI, La Voz de Misiones Internacionales" and using an English language slogan the "Voice of International Friendship." The station signs on at 1200 and goes off at 0500, airing mostly Spanish-language religious programming with a few English IDs tossed in here and there. The medium wave frequency is 1480 kHz. Reception reports can be sent to Apartado Postal (P.O. Box) 20583, Comayaguela, Distrito Central, Honduras. The station announcements say they're in Tegucigalpa Honduras.

Another new Honduran identifies as **Radio Galaxia** from Santa Barbara and is active on **6075**. So far, evening reception has been very tough due to the intense amount of interference this band sees during the night time hours, and apparently the station doesn't sign on early enough to provide much of a reception opening in the morning, before the band fades out for most North American listeners. The broadcasts, in Spanish, seem to be a relay of a sister FM station.

A new station has come on from Costa Rica. "**88 Estero**" from the town of Perez Zeledon, is also using **6075**! Its schedule runs from 1100 to 0500 using 1.5 kW. This may also be a shortwave relay of a local FM station. The address for this one is: Apartado 827-8000, Perez Zeledon, Costa Rica.

Can you use your shortwave radio to

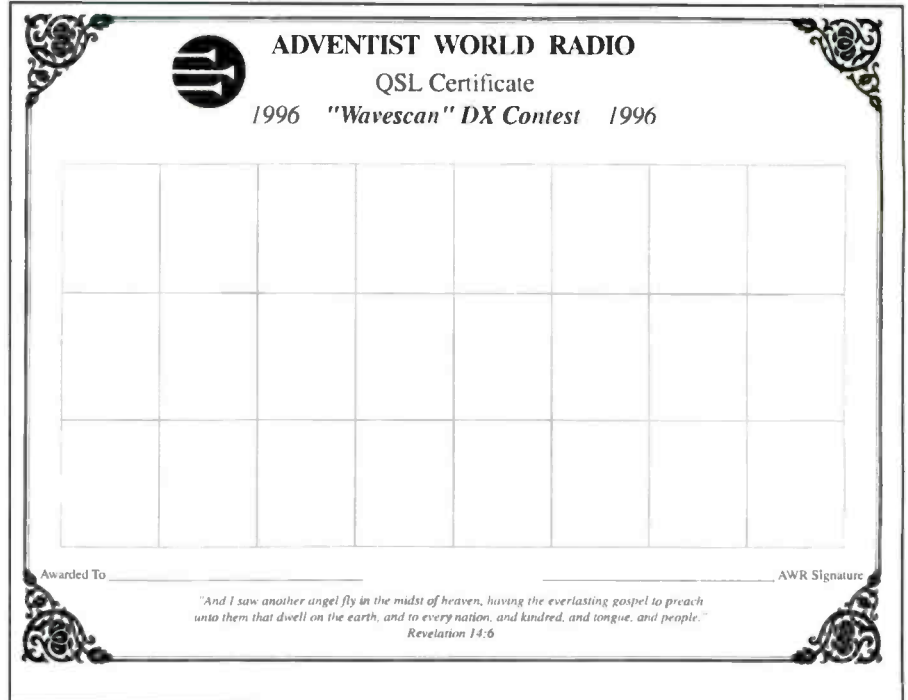

Adventist World Radio should be given some kind of an award for the exceptional interest and support they give to the DX and SWLing hobby. Their "Wavescan" program ran a contest last year which called for entrants to submit proof of reception of AWR program outlets in years past, as well as several other aspects of AWR listening past and present. My good friend, Bill Matthews won the '96 contest, the first ever American winner. Pictured above is the award certificate and the QSL stamps AWR issues for its various outlets.

Ree.

RADIO EXTERIOR DE ESPAÑA

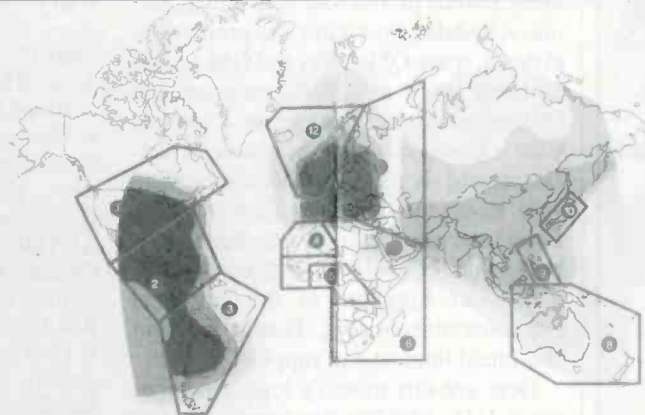

PROGRAMAS DIARIOS

UN IDIOMA SIN FRONTERAS

El español. Literatura, cursos y noticias en torno a nuestro idioma. Un programa elaborado en colaboración con el Instituto Cervantes.

VIAJE POR ESPAÑA

Una guía radiofónica completa con noticias de rutas turísticas, establecimientos hoteleros, playas, museos y gastronomía.

MUNDO SOLIDARIO

Programa dedicado a las Organizaciones No Gubernamentales (ONG). Los misioneros y cooperantes son sus principales protagonistas.

SUENA EN ESPAÑA

La música que se escucha en nuestro país.

ESPAÑOLES EN LA MAR

Información de la actualidad del mundo de la mar, la pesca, la meteorología y todo aquello de interés para los marinos.

■ Hispasat - 30° O

■ Eutelsat II-F6/Mot Bird I - 13° E

■ Asiasat 2 - 100.5° E

PROGRAMAS DE FIN DE SEMANA

YANGUARDIA DE LA CIENCIA

Programa divulgativo sobre la ciencia, tecnología y comunicaciones.

SIETE DIAS

Resumen de los acontecimientos nacionales e internacionales más importantes de la semana. Incluye, también, noticias de la vida parlamentaria española.

LA ACTUALIDAD A DEBATE

Una tertulia en torno a las cuestiones más destacadas del momento. Participan periodistas de otros medios de comunicación.

MUNDO MÉDICO

Programa dedicado a la salud. Dos ediciones semanales.

LA MÁSCARA

Entrevista con los protagonistas de la política, el cine, el arte y la sociedad española.

DEBATE EUROPA

Coloquio sobre asuntos comunitarios en el que participan varias emisoras públicas de los países de la Unión Europea.

ESPAÑA PARADA Y FONDA

Arte, historia, rutas, hoteles, gastronomía, precios, etc. La oferta turística de REE. Suplemento semanal de "VIAJE POR ESPAÑA".

AMIGOS DE LA ONDA CORTA

Dinamo y distors. Comunicaciones, satélites, receptores, parabólicas, frecuencias, emisores y todo lo relacionado con el mundo de las telecomunicaciones.

CLARÍN

Crónica del mundo de los toros, corrientes, ganaderías y toreros como protagonistas del ruedo.

TABLERO DEPORTIVO

La Liga española de fútbol es la gran protagonista de este programa que resume también la actualidad del resto de los deportes.

COBERTURA EN ONDA CORTA

- América del Norte
- América Central
- América del Sur
- México
- África Occidental
- África
- Oriente Medio
- Australia
- Filipinas
- Japón
- Europa Central
- Europa del Norte

SERVICIO MUNDIAL en Español

SERVICIO MUNDIAL DE NOTICIAS

Tres veces al día, en los horarios, 15 minutos con toda la actualidad de España y del resto del mundo.

DIARIOS HABLA DOS

Centros de llamadas de 50 minutos en directo a 06 13 18 y 21 11 para las grandes audiencias de REE. Informan, opinan, se escuchan y comentan con nuestra red de correspondientes.

DIARIO HABLADO CULTURAL

La Cultura en su sentido más amplio. La Literatura, el Cine, la Tierra, la Música, etc. Tres ediciones diarias.

CLAVES DE AMÉRICA

Después del Diario hablado de las 23.00 UTC, un análisis de las noticias de América, las claves y protagonistas interrelacionados en directo.

EL OJO CRÍTICO

Un espacio cultural vivo con todos los hechos y protagonistas de la vida de España y del mundo.

CRÓNICA

Información multimedia regional, local y provincial. Participan todos los espacios de RNE.

EMISIÓN PARA GUINEA ECUATORIAL

Todos los días una hora de información en directo en la actualidad de este país y del resto del mundo.

DESAYUNOS DE R-1 Y REE

Entrevista en directo de 50 minutos de duración con el protagonista del día en España.

RADIOGACETA DE LOS DEPORTES

Información de actualidad deportiva en Español.

INFORMATIVO PARA EL MAGREB

De lunes a viernes, los programas emitidos en noticias sucesivas de ese zona de África.

INFORMATIVO EN CATALÁN, GALLEGU Y VASCO

Las principales noticias del día de Cataluña, Galicia y del País Vasco, en sus respectivas lenguas.

Radio Exterior de España's colorful booklet shows their world coverage.

check on your portfolio? Maybe. The "Stocks and Funds Radio and TV Network" is being carried on shortwave, beamed to Africa and the Middle East using a pair of 250 kW transmitters at the Meyerton, South Africa transmitting site. You can write to these folks at 1733 Clifton Rd., NE, Atlanta, GA 30329.

The shortwave scene in Russia is so vast and so complex that it is virtually impossible to stay current with what's happening there, much less hear it all! But one recent development of interest is a newly licensed station called the **North European Radio Relay Service**, headquartered in St. Petersburg. The first tests of the station should have been carried out by now, although at this writing there's no information as to times or frequencies. The station's name would indicate they apparently plan to rent air time to other broadcasters.

Iraq is reported to have begun English language broadcasts again. **Radio Iraq International** is using **11895**. The English broadcasts only run for half an hour, beginning at around 2330.

Denmark, on the other hand, dumped the English language program that they had been airing as a part of a special Copenhagen celebration throughout last year. Sadly, it seems that the higher ups at **Radio Denmark** have no interest in airing broadcasts in any language other than Danish.

The most positive word you can apply to the following item is "unfortunate." **WWCR** has opened up yet another transmitter, and, during the prime evening hours, has parked it on **2390**, which is the long-time home of two rare and delightful Latin broadcasters: **La Voz de Atitlan** in Guatemala and Mexico's **Radio Huayacocotla**. If 120 meters must be used by a United States powerhouse shortwave broadcaster there are any number of frequencies in this band which could have been used without doing damage to other stations. Should we take up a collection and send **WWCR's** engineering department a copy of *Passport to World Band Radio*?

We hear that inactive **WINB**, Red Lion, Pennsylvania, may have returned to

the air by now. They'll be back to full strength (50 kW) and be beaming to Europe from 1700 to 1900 on **15715**, then on **11740** from 1900 to 2100. They'll also broadcast to Mexico from 2200 to 0300 using **11950**.

Psst! Hey, buddy, wanna buy a shortwave station? As we suggested some-time ago, **Prophecy Countdown's WVHA** has now gone on the sale block because the organization can no longer afford to make the huge payments on the facility it bought from **Herald Broadcasting** a couple of years ago and is also in a tax dispute with the town of Greenbush, Maine. Stay tuned.

Remember that your informational input to this column is always very welcome and appreciated! We ask only that you list your loggings by country, double space (minimum) between each item and include your name and address after each item. The logs get cut up and sorted, so if your name isn't indicated after each one we can't give you the credit.

We're also seeking all kinds of other stuff, including photos of shortwave sta-

Born In Cyberspace
 "Metrosoft has the scanners and accessories you want."
AOR & Bearcat Scanning Radios



To Order
Phone: 800-791-8941
Fax: 212-545-9594

AR8000/AR3000a/AR5000
 BC3000XLT/BC9000XLT/BCT10
 Grundig/Sony Multiband Shortwave Radios
 WinRadio Communications
 Receiver for your PC
 Plus, a wide selection of Radio
 Communications Computer Software
AOR accessories in stock!
 Catalog and order online at
<http://www.metrosoft.com/>
 E-Mail Address metrosoft@panix.com

Metrosoft Corp.
 165 Madison Ave., New York, NY 10016

CIRCLE 77 ON READER SERVICE CARD

FREE PRODUCT GUIDE
NEW 1997 EDITION

WORLDWIDE FIRESTIK!
 —VISIT OUR NEW WEB SITE—
 ★ COMPLETE ON-LINE CATALOG ★
 ★ VALUABLE TECHNICAL HELP ★
[HTTP://WWW.FIRESTIK.COM](http://www.firestik.com)

FOR PRINTED COPY WRITE OR CALL:
 FIRESTIK COMMUNICATIONS
 2614 E ADAMS, PHOENIX, AZ 85034
 TEL: 602-273-7151 FAX: 602-273-1836

CIRCLE 70 ON READER SERVICE CARD

World's Most Advanced Shortwave Radio

For **FREE** Information Package Call

219-236-5776

R.C. Distributing
 PO Box 552
 South Bend, IN 46624

CIRCLE 83 ON READER SERVICE CARD

tions, photos of you and your shack, station schedules, brochures and promotional items, spare QSL cards and QSL-related news (such as address changes and QSL requirements) and general news of what's going on with shortwave broadcasting and shortwave broadcasters. Send your items to: Listening Post, *Popular Communications*, 76 North Broadway, Hicksville, NY 11801. You can also e-mail your loggings to the editor at Popularcom@aol.com. Thanks for your continued interest and support!

Here are this month's logs. All times are in UTC which is five hours ahead of EST, i.e. 0000 UTC equals 7 p.m. EST, 6 p.m. CST, 4 p.m. PST. The language broadcast is assumed to have been English unless otherwise indicated by an abbreviation such as **FF, SS, PP, RR, AA** (French, Spanish, Portuguese, Russian, Arabic, etc.)

Abbreviations Used in Listening Post	
AA	Arabic
BC	Broadcasting
CC	Chinese
EE	English
FF	French
GG	German
ID	Identification
IS	Interval Signal
JJ	Japanese
mx	Music
NA	North America
nx	News
OM	Male
pgm	Program
PP	Portuguese
RR	Russian
rx	Religion/ious
SA	South America/n
SS	Spanish
UTC	Coordinated Universal Time (ex-GMT)
v	Frequency varies
w/	With
WX	Weather
YL	Female
//	Parallel Frequencies

ALBANIA—Radio Tirana, 7160 at 0229 with IS, EE ID. Mixing with an unidentified station underneath. (Maywods, KY) 0247 with woman on cultural topic. (Miller, WA)
ANGUILLA—Caribbean Beacon, 6090 at 0421 to 0600 carrying Dr. Gene Scott: Also 11775 at 1420-1600, with Scott. (Silvi, OH)
ANTIGUA—BBC relay, 5975, with Americas program stream at 0300 with news. (Jeffery, NY)
ARGENTINA—Radio Nacional, 6060, at 0023 in SS with Latin music. (Miller, WA)
ARMENIA (Tentative) Radio Free Asia on new 9440 in Tibetan at 1300 sign on with IS, ID "This is Radio Free Asia, the following program is in Tibetan." Woman with presumed schedule. Gave Washington address at 1328. Program repeated from 1330 to 1400 sign off. Weak carrier noted on possible 11615 parallel from Northern Mariana Islands. (Rausch, NJ)
ASCENSION ISLAND—BBC relay, 9600

with African program stream at 0312 with news, sports, "Network Africa." 15400 at 2000. (Jeffery, NY)
AUSTRALIA—Radio Australia, 9860 at 1730 and 17795 at 2131. (Miller, WA) 11800 at 1335. (Northrup, MO) 13755 at 2147 with discussion. (Foss, AK) 17795 at 2209 with news, 17860 at 2228 with "Australia All Over." (Jeffery, NY)
AUSTRIA—Radio Austria Int'l, 6015 (via Canada) heard at 0501 with news in GG. (Miller, WA)
BELGIUM—Radio Vlaanderen Int'l, 13685 at 1330 in EE with ID, news, "Radio World." (Jeffery, NY)
BENIN—Radiodiffusion du Benin, 4870 hrd at 0523 in FF with man talking, music. (Jeffery, NY)
BOTSWANA—Voice of America relay, 7415 at 0435 with news. (Foss, AK)
BOSNIA-HERCEGOVINA—Radio Yugoslavia relay, 15175 at 1527 in AA, with IS, ID and news. (Jeffery, NY)
BRAZIL—Radio Cancao Nova, Cachoeira Paulista, 4825 in PP at 0636 with inspirational messages, music. (Miller, WA)
Radio Brazil Central, Goiania, 4985 at 0155 in PP with music. (Miller, WA)
Radio Gaucha, Porto Alegre, 11915 at 2357 in PP with commercials. (Miller, WA)
Radio Universo, Curitiba, 9565 at 0006 in PP with man and woman taking turns speaking. (Jeffery, NY) 11765 at 2123 in PP with pop music, female announcer. (Miller, WA)
Radio Nacional da Amazonia, Brasilia, 6180 at 0800 in PP with Brazilian music and 11780 at 2324 with soccer broadcast. (Miller, WA)
Radio Guiaba, 6000 (tentative), 0150 to 0400 under Radio Havana, US pops and other selections. (Silvi, OH)
Radio Cultura, Sao Paulo, 9615 at 0029 in PP with soft guitar music. (Jeffery, NY)
Radio Anhanguera, Goiania, 4915 hrd at 0014 in PP with IDs, talk by man, commercials. (Jeffery, NY) 11830 at 2345 in PP. (Miller, WA)
BULGARIA—Radio Bulgaria, 9485 at 0046 to 0059 close. Also 9700 at 2154 (in BB). (Miller, WA) 9485 at 0517. (Foss, AK)
CAMEROON—CRTV Yaounde, 4850, re-activated and heard in EE at 2035 with pops and bios on singers. Mission Impossible theme to ID and time check. International and regional news on the hour and ID 2110 "This news comes to you from the national service of Radio Cameroon." Into FF at 2115 and off with anthem at 2357. (Rausch, NJ)
CRTV, Bertoua, 4750 at 0501 in FF with talk by man, woman. (Jeffery, NY)
CRTV, Buea, 3970 in FF at 0509 with talk. (Jeffery, NY)
CANADA—Radio Canada Int'l, 1855 at 1400 with news. (Northrup, MO)
BBC via Canada on 9590 heard at 2300. (Jeffery, NY)
CBC Northern Quebec service, 9625 at 1509 with native language program. (Jeffery, NY)
CHAD—Radiodiffusion National Tchadienne, 4904.5 in FF at 2135. (Yohnicki, ON)
CHILE—Radio Esperanza, Temuco, 6090 at

0305 in SS with religious programming. (Miller, WA)

CHINA—Fujian People's broadcasting Station. 4975 at 0923 in CC. (Foss, AK)

Central People's Broadcasting Station, 4800 at 1456 with ID, mellow western-style music. (Boulden, CA) 4905 at 2210 in CC with music, talk by woman. (Jeffery, NY)

COLOMBIA—Caracol Colombia, 5077 in SS at 0053. (Miller, WA)

COSTA RICA—RFPI, 7385 at 0201. (Jeffery, NY) 0952. (Foss, AK)

Radio Reloj, 4831 at 0657 in SS. (Miller, WA) 4832 at 0513 in SS with talk, ID, music. (Jeffery, NY)

Adventist World Radio, 5030/9725 from 0332 to 0430 in SS with music. (Silvi, OH) 9725 at 2348 in SS. (Miller, WA)

Radio Exterior de Espana relay, 3210 at 0333 in SS. (Miller, WA)

CROATIA—Croatian Radio. 5895 at 0200 with IS, ID, EE ID, news read by woman. (Maywoods, KY)

CUBA—Radio Havana Cuba. 6180 at 0400 with "Jazz Place." (Silvi, OH) 11760 at 1400 with news in SS. (Northrup, MO) 11970 at 2353 in PP. (Miller, WA)

ECUADOR—3220 at 1250 to 1327 fade. (Silvi, OH) 9415 at 0031 in FF. (Miller, WA) 15140 at 2157 in SS. (Foss, AK)

Radio Quito, 4915 (nominal 4920, Ed) at 0713 in SS. (Miller, WA)

EGYPT—Radio Cairo, 9900 hrd at 2213 in AA with music and woman announcer. (Miller, WA)

ENGLAND—BBC, 3955 with European program stream at 0407. (Jeffery, NY) 6175 (via California) at 0703, 6195 at 1513, 7135 (via Singapore) at 1638, 11765 at 2201 in PP. (Miller, WA) 9515 at 1350 with news. (Northrup, MO)

FINLAND—Radio Finland Int'l, 11735 at 1330 with news. (Northrup, MO)

FRANCE—Radio France Int'l, 9485 with news at 12, 14 and 1700. 11710 at 0230 in SS with soccer, 11995 at 0002 in PP. (Miller, WA)

FRENCH GUIANA—Radio France Int'l relay, 9800 at 0516 with news in PP. (Miller, WA) 15200 at 2204 in possible Italian. (Foss, AK)

GABON—Africa Number One, 9580 at 2033 in FF with African music. (Miller, WA) 17630 at 1421 with music. (Jeffery, NY)

GERMANY—Deutsche Welle, 3995 in GG at 0656. (Foss, AK) 5960 with "European Journal" at 0132, 9870 at 2320 in GG, 11785 at 2008 in EE, and 11795 at 2344 in GG. (Miller, WA) 11795 at 1355 with IS, into GG. (Northrup, MO)

GHANA—Ghana Broadcasting Corporation, 4915 at 0357 in unidentified language, African music. (Miller, WA) 0532 in EE with African music. (Jeffery, NY)

GREECE—Voice of Greece, 9425 in Greek at 1615 with news. (Miller, WA) 11645 at 1355 in Greek with music. (Northrup, MO)

GUATEMALA—Radio Tezulutlan, Coban, 4835 at 0220 in SS and 0310 in Quechua. (Miller, WA)

The Best* Just Got Better!

The Eavesdroppers™ now includes our new Zap Trapper™ Electronic Gas Tube Lightning Arrestors. Receive-only design shunts damaging transients to ground at only 1/7th the voltage buildup of the available 200 watt transmit-type arrestors, providing maximum solid state receiver protection.

Protect your investment - combine an excellent shortwave receiving antenna with the best receiver protection money can buy.



- Completely assembled and ready to use
- Only 42' overall length
- 8 trap circuits permit reception on all shortwave bands, 11-90 meters.
- All connections soldered and enclosed in ultrasonically-welded, hermetically-sealed trap covers
- Includes 50' of 450 lb. test nylon rope

Model T includes 100' twinlead feedline
Model C includes weatherproofed center connector for your coax & coax sealant

- Either model \$79.95
- UPS for lower 48 states \$6.00
- COD add \$4.75, IL add 8.25% sales tax
- Foreign shipping coated

* "The best... built like an antenna should be." -Larry Magne in *World Radio TV Handbook*

* "Our best seller." -EEB in their recent ads and catalogs

* "Now in use in 45 countries." -Giffler Shortwave in 1983

Antenna Supermarket

P.O. Box 563 Palatine, IL 60078 Tel (847) 359-7092 Fax (847) 359-8161

At your dealer or direct • Visa & Mastercard accepted

The Complete RF Technician's Handbook

The Complete RF Technician's Handbook

The Complete RF Technician's Handbook will furnish the working technician or student with the latest methods and circuits used in RF communications gear.

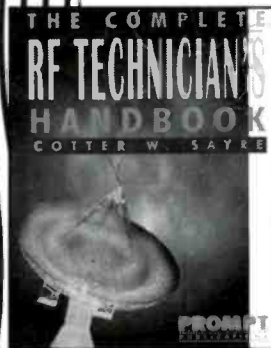

Includes information on:

- ~ Reactance
- ~ Impedance
- ~ Phase Angles
- ~ Decibels
- ~ Semiconductors

\$24.95 ~ 281 pgs.
ISBN# 0-7906-1085-X

Call for the name of your local distributor:

800-428-7267

www.hwsams.com

PROMPT
PUBLICATIONS

The Complete RF Technician's Handbook

The Complete RF Technician's Handbook



Radio Jordan
P.O. Box: 909 Amman

THANK YOU

STEVEN THOW
5583 RANDALL AVENUE
MONTREAL, QUEBEC, CANADA H4V 2V9

Date: 3/10/ '96

We have the pleasure to confirm your reception report dated 9/21 '96 on the frequency of 11970 KHz, at 1540 GMT. The programme details mentioned in your report have been checked and found correct. Thank you for listening to our transmission, and best regards from Radio Jordan in Amman.



Sincerely,
JAWAD ZADA
Director

RADIO JORDAN AMMAN

SHORT WAVE FREQUENCIES
Effective May 1st '95

UTC	22	23	24	1	2	3	4	5	6	7	8	9	10	11	12	13	14	15	16	17	18	19	20	21		
JLT	0	1	2	3	4	5	6	7	8	9	10	11	12	13	14	15	16	17	18	19	20	21	22	23	0	
Arabian Gulf, Far East, Australia																										
Egypt, Sudan, East Arabia, East Africa																										
Central & Eastern Europe, Moscow																										
North Africa, Central America																										
South America, Brazil																										
North America, Western Europe																										
Western Europe																										

Legend: ARABIC (black bar), ENGLISH (grey bar)

RADIO JORDAN
TEL 77 41 11
FAX 74 26 62
P.O. BOX 909
AMMAN - JORDAN

It's almost easier to haul an elephant around on your back than it is to dig a QSL out of Radio Jordan. Steven Thow in Montreal, Quebec, got two of them, one of which he shares with us. (The reverse side shows their schedule.)

Radio Chortis, Jacotan, 0331 in SS on 3380. (Miller, WA)

Radio Maya de Barillas, Huehuetenango, in SS at 0144 on 3324. (Miller, WA)

HAWAII—KWHR, 13625 at 1908 with upbeat religious music. 17510 at 2202 in CC with talk by woman. (Jeffery, NY)

HONDURAS—La Voz Evangelica, 4819 (nominal 4820) in SS at 0020 with talk. (Jeffery, NY) 0559 in SS. (Miller, WA)

HUNGARY 4820 at—Radio Budapest, 6130 at 1508 in HH with news and 9825 at 1640 with news in HH. (Miller, WA)

INDIA—All India Radio, 7250, AIR Panji (Goa) at 0129 with IS, woman talk, sub-continental music. (Maywoods, KY) 10330 at 0046 in Hindi. (Miller, WA)

INDONESIA—Radio Republik Indonesia, Jayapura, 6070 at 1413 in II. (Miller, WA)

ISRAEL—Kol Israel, 11605 at 1505 with news, features about a cultural festival. (Jeffery, NY) 1900 in Hebrew. (Miller, WA)

ITALY—RAI, 6110 at 0138 in II and EE, 9675 at 1841 in II. (Miller, WA)

IVORY COAST—Radio Cote D'Ivoire, 7215 at 2207 in FF with African rap and pops. 2300 with ID "Ici Cote D'Ivoire" and more African music. (Miller, WA)

JAPAN—Radio Japan, 7200 at 1706 with Asian news. Also 7225 at 1712 with feature. (Miller, WA) 9535 at 1422 about Japanese consumption tax. (Boulden, CA) 11705 at 1355 in JJ. (Northrup, MO)

KUWAIT—Radio Kuwait, 9855 at 2030 with discussion in AA. (Miller, WA) 11990 at 1821 with music, ID, news. (Jeffery, NY) 1830 with news. (Bryson, PA) 15505 at 0737 with Arabic music. (Foss, AK)

LITHUANIA—Radio Masakonas, 9709.8 in GG and EE at 1300 sign on to 1430 sign off. Lithuanian and EE IDs "This is radio station Masakonas, transmitting from 9710 kilohertz. We now broadcast programs from the Universal Life Network." Universal Life programs in EE and GG, Universal Life ID and addresses in U.S. and Germany. Off at 1430. This is aired on Sundays only. (Rausch, NJ)

MALI—RTV Malienne, 5995 at 2232 in FF with tribal music. (Miller, WA)

MEXICO—Radio Mexico Int'l, 5985 in SS at 1245. (Yohnicki, ON) 9705 at 2351 with Mexican music, SS announcements. (Miller, WA) 0152 with SS vocals. (Maywoods, KY)

MONGOLIA—Radio Ulaanbaator, 4850 at 0929 in unidentified language, male-female conversation, martial music. (Miller, WA)

MOROCCO—Radio Medi-Un, 9575 heard at 0506 in AA and up-tempo Moroccan music. (Foss, AK)

NEW ZEALAND—Radio New Zealand Int'l, 11905 at 0632 with "Story Time." (Miller, WA)

NETHERLANDS—Radio Netherlands, 9605 (via Madagascar) at 1753. (Miller, WA)

NETHERLANDS ANTILLES—Radio Netherlands Bonaire relay, 5995 at 0501 and 6165 at 2346. (Miller, WA) 11730 at 1405 in Scandinavian language. (Northrup, MO)

NIGER—La Voix de Sahel, 5020 at 2229 in FF with hi-life music, talk. (Maywoods, KY)

NIGERIA—Radio Nigeria, Kaduna, 4770 at 0502 with news, ID. (Jeffery, NY)

NORTHERN MARIANAS—KHBI-Monitor Radio, Saipan, 9355 at 1655. (Miller, WA) 13840 at 2034 with news. (Foss, AK)

NORTH KOREA—Radio Pyongyang, 11335 at 0000 with IS, ID, anthem and news. (Jeffery, NY)

Korean Central Broadcasting System, 2850 at 0702 with song by what sounded like a group of hundreds of singers. (Foss, AK)

PAPUA NEW GUINEA—NBC Port Moresby, 4890 at 0828 with pops. (Miller, WA) 1315 with listeners phoning in greetings. (Silvi, OH)

PARAGUAY—Radio Nacional, 9735 at 2346 in SS with comments. (Miller, WA)

PERU—Radio Union, Lima, 6115 in SS at 0308 with commercials. (Miller, WA)

Radio Cora, Lima, 4914 at 0441 in SS. (Miller, WA)

PHILIPPINES—Radio Veritas Asia, 6020 at 2229 with EE announcement, church bells IS and into Mandarin. 11825 at 2259 with EE ID

and into Indonesian. (Miller, WA)

QATAR—Qatar Broadcasting Service, 7210 at 1958 in AA with music, time pips, ID "Dihaar al Qatar min Al-Doha" and news in AA. (Maywoods, KY) 15395 in AA at 0733 with Arabic music. (Foss, AK)

RUSSIA—Voice of Russia, 5995 at 0153 with news. 6150 at 0459 with IS. (Miller, WA)

Magadan Radio, 9530 at 0002 in RR with woman, man talk; music. (Jeffery, NY)

Golos Rossi, 6065 at 0459 with new musical theme. News in RR at 0500. Also 12015 at 0728 in RR. (Foss, AK) 9705 at 2200 in RR. (Miller, WA)

Chitak Radio, Atamanovka, 4860 in RR at 0440. (Miller, WA)

Radio Novaya Volna, Chelyabinsk, 6020 at 1347 with talk show in RR. (Miller, WA)

SAUDI ARABIA—BSKSA, 9555 to North Africa and parallel 9870 to Europe, 1756 to after 2000. Nice AA music. (Silvi, OH)

SEYCHELLES—FEBA, 9810 at 1528 with inspirational messages by woman and pops. (Miller, WA)

SINGAPORE—Radio One, 6155 at 1516 with contest program from their local FM. (Miller, WA)

SLOVAKIA—Adventist World Radio relay, 6055 at 2100 with ID, interview, commentary and "Wavescan." (Jeffery, NY)

SOLOMON ISLANDS—SIBC, 5020 at 0841 with mention of time for service announcements. (Miller, WA)

SOMALIA—Radio Mogadishu—Voice of the Somali People, 6870 upper sideband, in EE at 2000 with martial music, IS. ID "This is the international shortwave service of Radio Mogadishu" and into international news. (Rausch, NJ)

SOUTH AFRICA—Channel Africa, 15240 at 1604 with news, story on traffic offenders. (Boulden, CA)

Trans World Radio via South Africa, 9510 at 2050 in Swahili with sermon, chorus. (Miller, WA)

SPAIN—Radio Exterior de Espana on new 6055 (replacing 9540) at 0011 with "Window

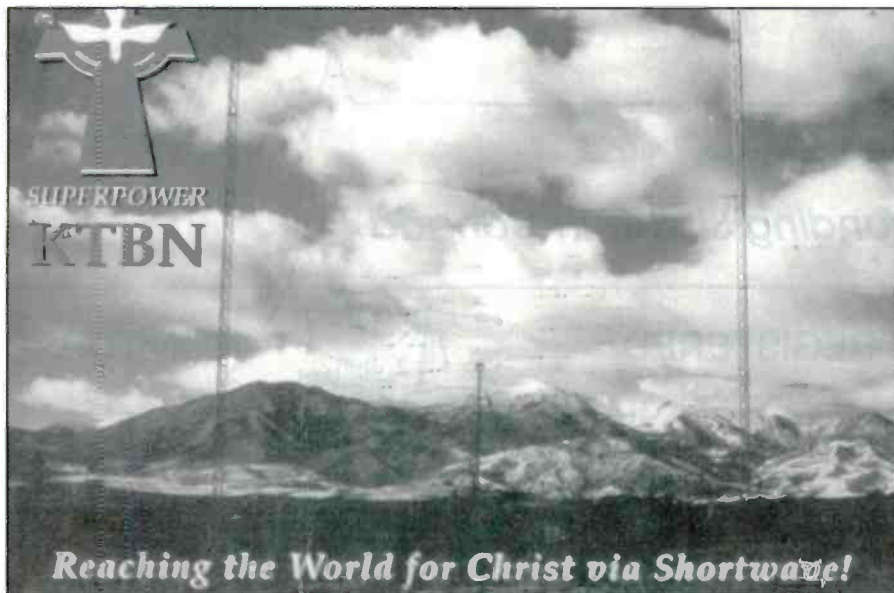

Thanks to Michael Tucker for sending this full color QSL from KTBN, Salt Lake City. This religious broadcaster is owned by the Trinity Broadcasting Network and relays their programming.

0900 with music theme, woman in CC. (Miller, WA)
THAILAND—BBC relay on **9580** at 0017 with "Newsdesk." (Jeffery, NY)
TOGO—RTT, Lome, **5047** at 0543 in FF with woman talk. (Jeffery, NY)
UZBEKISTAN—Radio Tashkent, **9540** in AA at 1900 with anthem-like IS to AA ID. Into international news and Uzbek folk music. Into GG at 1935. (Rausch, NJ)
VENEZUELA—YVTO time station, **5000** at 0418 with time announcements in SS. (Miller, WA)
Radio Tachira, **4830** at 0651 in SS with Latin music. (Miller, WA)
VIETNAM—Voice of Vietnam, **9840** at 1812 in EE.

A monster-size cheer for the good guys who came through for you this month: Brian Boulder, Fairfield, CA; Lee Silvi, Mentor, OH; John Bryson, Mt. Joy, PA; Mark Northrup, Gladstone, MO; Mike Miller, Issaquah, WA; Michael Yohnicki, London, ON; Marty Foss, Talkeetna, AK; Ed Rausch, Cedar Grove, NJ; Dave Jeffery, Niagara Falls, NY and the Maywoods, Kentucky DX Group (Jim McClure, Chuck Everman, Jerry Johnston, Joe Roitman and Ed Shaw). Thanks to each one of you.

Until next month—good listening! ■

on Spain," ID, other features to news at 0100. (Jeffery, NY)
SOUTH KOREA—Radio Korea, **15575** at 2257 in KK with EE announcement, IS. (Miller, WA)
SURINAM—Radio Apinte, **4990.95** at 0210 with talk and mention of "Apinte."

SWEDEN—Radio Sweden, **6065** at 0030 with "60 Degrees North." (Miller, WA)
15240 at 1448 with "60 Degrees North." (Jeffery, NY)
SWITZERLAND—Swiss Radio Int'l, **12075** at 1500 with news. (Jeffery, NY)
TAIWAN—Voice of Free China, **7445** at

THE REVOLUTIONARY CHEROKEE® CB RADIOS

"Now You're Talkin'"SM

World's First
 AM/SSB
 Handheld
 Only 6 1/2" Tall!

CM-5
 AM Mobile in
 a Miniaturized
 Design



AH-27
 AM
 40 Channel
 Handheld

AH-27-YL
 Sports Yellow Version

AH-100

CBS-1000 AM/SSB Base Station

Cherokee, the new technology leader in CB radios, offers a full line of innovative, exciting new CB's. From our first model, the revolutionary AH-27 miniature handheld, all the way to our CBS-1000 AM/SSB base station, Cherokee stands alone in our commitment to quality, advanced technology, and performance. With a Cherokee CB radio, "Now You're Talkin'"SM

For More Information on these radios and where you can purchase them, call us a 1-800-259-0959, or visit us on the web at <http://www.wirelessmarketing.com>

Cherokee is a registered trademark of the Wireless Marketing Corporation, Schaumburg, Illinois 60008

27 MHz COMMUNICATIONS ACTIVITIES

Sidebanding Sizzles in Canada

“Radio Canada is enjoying phenomenal growth in sideband operators,” says Wayne Beaudrey, Dominion coordinator for the Radio Canada DX Group. “We’re adding 200 new members a month, and total membership in the club is now well over 2,000” Beaudrey says. He continued, “Many of the new members are people who were into CB during the boom 20 years ago and who are now renewing their interest in the hobby.”

Because many of the new members are old hands, the quality of operators is exceptional, and we find many of them are dusting off their old gear and lovingly restoring it.”

It’s not uncommon, Beaudrey says, to hear restored Golden Eagles and Centurions on the air. Cobra 2000s are another highly desired radio and often sell for high prices.

Perhaps surprisingly, a fair number of Radio Canada members are also ham radio operators. “I think they enjoy the fact that we are a self-regulating, well-disciplined group that operates without a great deal of formality,” Beaudrey says. That makes sense, though the motto of Radio Canada DX Group is “Friendship through radio.”

Established in 1969, the Radio Canada DX Group is a radio club interested primarily in sideband DX operations. Members not only operate on channels 16, and 31-40 LSB (the same 40 channels as in the United States).

“We leave channels 1-30 to the AM operators except for Ch. 16, and we also encourage channel 9 monitoring and assistance activities of REACT,” Beaudrey says.

The club itself seems to be a class operation. Radio Canada DX Group has, for example, its own World Wide Web page <www.cyberbeach.net/~rc1720/rchome.htm>. Each province in Canada has its own coordinator and sideband calling frequency. There is also a terrific packet of information and a newsletter that members receive.

If you’re interested in membership in the Radio Canada DX Group which is

REGISTERED

MONITOR

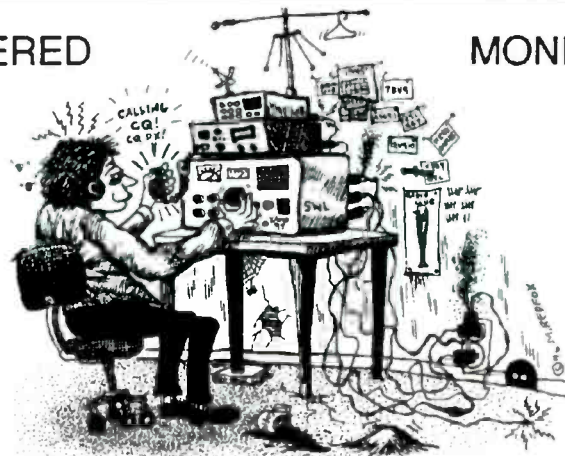

K W A 7 D Q

Mark Redfox
814 Columbia #32
Seattle, Wa. 98104

These fine-looking cards were designed by Mark Redfox.

limited to Canadian citizens, visit them at their Web page or write to them at: Radio Canada DX Group, PO Box 287, Levack, ON P0M 2C0. Don’t forget to tell ‘em you saw it in *Pop’Comm*.

Midland Introduces Weather Radio Equipped Portable CB

The folks at Midland seem determined to raise the standards for CB gear. The Model 75-810 features a full 4 watts transmit power (or battery-saving 1 watt for short range) and 40 channel synthesized circuitry. The large orange LCD readout is backlit and has 3/8" high numerals, a 10-segment sequential power/signal meter and indicators for high/low power, EMG, CB/WX modes, battery low and keyboard lock. There is instant access to emergency channel 9, two user-selectable memory channels and a button for accessing the last busy channel you received.

The Midland 75-810 is equipped to receive all seven NOAA and three Canadian weather channels for up-to-the-minute local weather reports, as well as

“It’s not uncommon, Beaudrey says, to hear restored Golden Eagles and Centurions on the air.”

bulletins for severe weather and hazardous conditions such as toxic chemical spills or earthquakes.

Measuring 6.5" high by 2" wide by 2.5" deep, the Midland 75-810 has a low-profile BNC-mount flex antenna, 12 Vdc power cord with cigarette lighter plug and carry strap. The ABS case has jacks for in-unit battery charging, an external antenna, external power, remote mic/speaker mic, and earphone. The radio is powered by 9 AA alkaline or rechargeable NiCd batteries (sold separately).

The suggested retail price for the Midland Model 75-810 is \$149.95. Available accessories include the Model 22-410 speaker-mic (\$39.95), Model 22-430 voice-activated throat mic with earphone/PTT box/remote PTT (\$69.95), and Model 18-390C AC charger (\$22.95).

For additional information, contact Midland Consumer Radio, Inc., PO Box



Midland's new 75-810 offers sharp looks, 40 channels AM, and 10 weather channels.

33865, Kansas City, MO 64120-3865 or telephone 816-241-8500. Be sure to mention you saw it in Pop'Comm!

Firestik Offers New Catalog; Launches Web Site

Firestik Antenna Company, well-regarded for its high-performance CB antennas has published a 28-page full-color guide to its antennas and accessories for CB, scanner, cordless phones, and amateur radio. The product guide highlights a variety of CB antennas, kits and accessories for use on cars, trucks, RVs, motorcycles, boats, and big rigs. In addition, the '97 guide provides valuable information on the setup and testing of antenna systems and lists the 10 most common problems that create poor SWR.

If you would like to receive a free copy of the Firestik 97 catalog write to them at: Firestik Antenna Company, 2614 E. Adams St. Phoenix, AZ 85034-1495 or by calling 602-273-7151. If you've got a



4091 Viscount Street
Memphis, TN 38118
(901) 794-9494
Fax: (901) 366-5736

ANTENNAS • POWER SUPPLIES • ACCESSORIES

HIGH PERFORMANCE and MADE IN U.S.A.

MACO 150



MACO 150

RECEIVE AMPLIFIER with dual gate MOSFET FOR HIGH GAIN AND LOW NOISE. Gain is adjustable from -20db to +27db (5 S units) with exclusive noise emulator circuit. For SSB or AM Base Stations 110v AC operation.

MACO 91 Match Box



MACO 91 Match Box

Correct high SWR between radio and antenna handles 300 watts maximum power.

Call or write for free catalog and name of reseller near you.

CIRCLE 75 ON READER SERVICE CARD

computer and Internet capability, you'll want to visit Firestik's World Wide Web page at <www.firestik.com>.

In addition to information about Firestik's products, you'll find technical information such as 60-plus facts that every CBER should know, complete step-by-step SWR tuning instructions, steps and diagrams for processing coax and coax connectors, and answers to a list of frequently-asked questions. The site also provides a series of fill-in-the-blank forms that offer personalized technical assistance, help in locating specific Firestik products, and a literature order form. Check it out!

Redfox QSL Cards

A while back, I mentioned that for a small fee, Mark Redfox, 814 Columbia #32, Seattle, WA 98104 will design QSL cards for CBERs. Recently, he sent me three examples of his designs. The work speaks for itself. If you need a distinctive, completely unique QSL card, you might want to contact Mark and see what he can cook up for you.

Mark has also become the president for North and South America for the Victor

Echo—Viking European—DX Group, which is headquartered in Bron, France and the controller for the Echo-Tango Group from Veyer, France. If you would like membership information for either one of these groups, please contact Mark at the address above.

From the Mail Bag

Rodney Hedrick, owner of a small CB shop in Harrisonburg, VA, wrote to say that "I have problems with this bill that would allow local authorities to deal with interference problems. I have seen some high power radios that would interfere with other channels. I have also seen a 4 watt, 80 percent modulation radio also cause interference on other channels.

I use a Cobra 2000 and a power mic, and on a good day when the weather is right, I will bleed my phone, my TV, and my stereo.

"Perhaps surprisingly, a fair number of Radio Canada members are also ham radio operators."

"If you need a distinctive, completely unique QSL card, you might want to contact Mark and see what he can cook up for you."

Basically I think the proposed bill stinks because if someone does not like you or your hobby, they will call they law and you will get a fine."

Well, Rodney, I basically agree. Even though I really don't like unruly operators, particularly those who knowingly screw up emergency communications, I think the downside on this proposed bill waay too big. The sad truth is that the average local law enforcement official probably doesn't understand anything about interference problems. For example, many stereo, TV, and phone manufacturers have ignored their responsibility to build quality gear that can reject interference from CBs that are being operated within legal specifications. Fortunately, it looks like this bill is dead in the water for the foreseeable future.

CIRCLE 81 ON READER SERVICE CARD

CIRCLE 82 ON READER SERVICE CARD

The Radio Canada DX Group uses this handsome QSL card.

Hisayoshi Tanaka (nickname Riki), 1350 Izumi-Cho Izumi-Ku, Yokohama City, Kanagawa 245 Japan, wants to swap CB QSL cards. Niki reports that in Japan there are eight channels of 500 mW unlicensed, AM-mode CB, starting at 26.968 and going to 27.144 MHz.

Frank Kulak wrote looking for help building an antenna he saw years ago. It's a yagi-style antenna for CB, but the elements are only about 18" long on either side of the boom. It sounds more like a 2-meter antenna to me, but I'm not an antenna expert. So, if you know of a CB beam with really short elements, please send info me here at the column, or communicate directly with Frank at 579 Taylor Dr., Canonsburg, PA 15317-2829.

Steve Kaufman wrote a lengthy letter from Philadelphia in which he said, basically, that we hold a double standard in this column in which we are afraid to acknowledge "that many CB operators are running radios with extra frequencies ... or 10 meter radios."

Well, Steve, the fact is that right now in the U.S., 11-meter enthusiasts are in sort of a weird place. The 40 legal channels are licensed—but they are licensed by rule-making. That means simply if you operate there you fall under the rules and regulations the FCC has created for Citizens Band radio. And the rules say that only type-accepted radios may be legally used within those frequencies.

Now, if you operate outside of the 40 legal channels but someplace between 26 MHz and 28 MHz, you are simply an unlicensed operator, which is also illegal.

Technically, you are just as illegal as if you decided to operate on the same frequency as an airport control tower or a fire emergency frequency. In the eyes of the law, unlicensed is unlicensed, and it doesn't matter where you are operating or what sort of radio you are operating. Those are the legal facts of the case.

From my own personal experience, however, I find that outband operators are LESS likely to cause interference problems than unruly operators within the 40 legal channels. In addition, I find that outbanders are generally high quality operators, running top-quality radios that are properly adjusted. I suspect that outbanders do a great deal to promote international friendship, and many of them are my friends.

Perhaps the smartest course would be if the FCC were to take an OFFICIAL hands-off attitude in regard to 26-28 MHz, with the exception of big, nasty, punitive fines for anyone intentionally interfering with emergency communications on Ch. 9. I don't think I'd have a problem with that.

Finally, Steve, your letter raises interesting questions for your humble columnist: Should we then begin testing 10-meter radios alongside the type-accepted CBs? If so, should we then also begin testing high-end ham transceivers which can also be made to transmit on 26-28 MHz.? It is an interesting question.

Until the next time, thanks for all your cards and letters. Keep them coming to CB Scene, and don't forget to include your shack photo!

How I Got Started

Scanning—Maybe It's Hereditary!

We invite you to submit in about 150 words how you got started in the communications hobby. Entries should be typewritten, or otherwise easily readable. If possible, please try to include your photograph (no Polaroids, please) with your submission.

Each month, we'll select one entry and publish it here. Submit your entry only once and we'll keep it on file. All submissions become the property of *Popular Communications*, and none will be acknowledged or returned. Entries will be selected taking into consideration the story they relate and if it is especially interesting, unusual or even humorous. We reserve the right to edit all submitted material for length and grammar, and to improve style.

The person whose entry is selected will receive a one-year gift subscription (or renewal) to *Popular Communications* magazine. Address all entries to: How I Got Started, *Popular Communications*, 76 North Broadway, Hicksville, NY 11801-2909, or e-mail to <popularcom@aol.com>. If you decide to e-mail your entry, please let us know if you're sending a photo.

Our April Winner

This month we've chosen Jerry T. Oglesbee from Sour Lake, TX as our winner. Jerry says: I got started in the radio hobby by my friend's dad, Mr. Windsor Head. As chief mechanic for the city of Beaumont, TX he'd monitor police and fire comms to plan the next day's activities at the city garage. He had a four-channel crystal-controlled Bearcat scanner.

His son, Harold and I would be passing by and catch some police chatter or news of a fire somewhere in town. I would ultimately sit glued to every word the scanner produced. From that point on, I was hooked.

I soon went looking for my own "police monitor" to have at my house. At first I could only afford an inexpensive one, but then moved on to a Realistic Patrolman 4. It had a squelch control on it! It was great!



Here's Jerry Oglesbee and his son Tad at the controls of their computer. The surrounding radio equipment is a Trident 1200, 2400, and a Sangean ATS 803A. On the computer cpu are two General Electric radios. The upright one is a model P1864A multi-band from the late '60s or early '70s. The other one is a model P715-D AM band from 1958.

Then Beaumont went to 460 MHz. Not every radio receiver was equipped to tune that high in the '60s. I put all my money into another Realistic receiver. I've forgotten the model, but I could pick up the police transmissions from Beaumont's finest. Still, there were two channels for the police at 460 MHz, but the fire department was still at 154 MHz, and then there was the mutual aid channel. There were simply too many channels for an analog dial receiver. Enter my first scanner—a Bearcat, circa 1970.

Today I have 2,000 channels at my disposal with a Trident 1200, 2400 and a Sangean ATS 803A. My spectrum of listening goes from 100 kHz to 2.068 GHz. You can run, but you can't hide!

I also have fun going to garage sales and finding old AM sets that people have tossed out. So many are out there with memories galore.

My son, Tad, seems to have caught the scanning bug from me. I only hope he gets as much enjoyment from the hobby as I have. I wonder if it is hereditary? My love for electronics was also strengthened by a neighborhood peer, Steve Williams, but that's another story! ■

FREEPLAY®..

...FREE POWER

NO BATTERIES REQUIRED

BAYGEN is...The leader in personal power generation. **Just wind it up and turn it on!**

FREEPLAY RADIO



The World's only **completely battery-free**, wind up AM/FM and Shortwave radio!

The power source is an internal B-Motor carbon steel spring driving a generator that is powered by hand..

Put the power back in your hands and

contact BayGen today.

Dealer inquiries welcome.

1 800 WIND 234

CIRCLE 66 ON READER SERVICE CARD

ELECTRONIC COMPONENTS

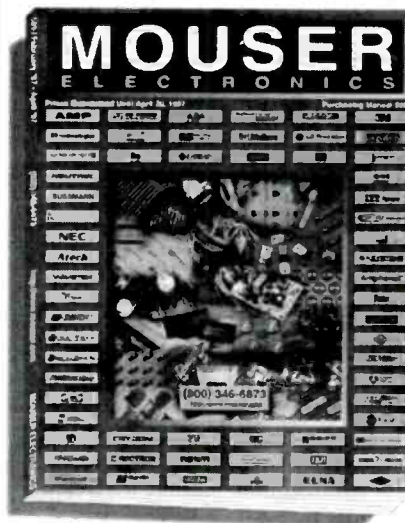

Call for your **FREE** 340 page catalog **TODAY!**

- 68,138 Products
- 128 Manufacturers
- All Orders Ship Same Day
- No Minimum Order

800-992-9943 FAX: 817-483-0931
<http://www.mouser.com> catalog@mouser.com

958 North Main St., Mansfield, TX 76063

CIRCLE 79 ON READER SERVICE CARD

Broadcast DXing

DX, NEWS AND VIEWS OF AM AND FM BROADCASTING

Satellite Radio Moves Ahead

Satellite-delivered digital audio could take a step closer to reality with the FCC auction this month of 25 MHz of spectrum above 2310 MHz. At least four companies are set to bid for licenses for the proposed digital audio radio service (DARS), which would deliver dozens of channels of CD-quality music, news and other programming directly to homes and cars equipped with special S-band receivers and small silver dollar-size antennas.

Three major DARS developers had sought what's called a "pioneer's preference," which would have rewarded the companies for their efforts in developing the service with a guarantee of a license. In November the FCC denied their bids, opting instead to auction the spectrum licenses by April 15.

Still, DARS proponents remain optimistic about the future of the service, which would operate much like TV's DirecTV and Primestar. The FCC is finalizing rules for DARS, and the four major developers are making plans to move ahead with their respective services. "We're going into this business," CD Radio Chairman David Margolese told *Broadcasting & Cable* magazine.

David vs. Goliath, Round Two

St. Louis radio entrepreneur Tim Dorsey has taken another step in his ongoing challenge to KMOX by setting the stage to move all programming from upstart WIBV to KSD-AM. Charter Communications, in which Dorsey is a minority investor, will buy KSD-AM from EZ Communications for a reported \$13 million, pending FCC approval. The planned move of WIBV programming from 1260 to 550 kHz offers improved coverage of the St. Louis, MO market. "This levels the playing field," Dorsey told the *St. Louis Post-Dispatch*. "We now have the best talent in St. Louis and the best signal in St. Louis."

KSD-AM's new format will be full-service: news, talk and sports. Plans at

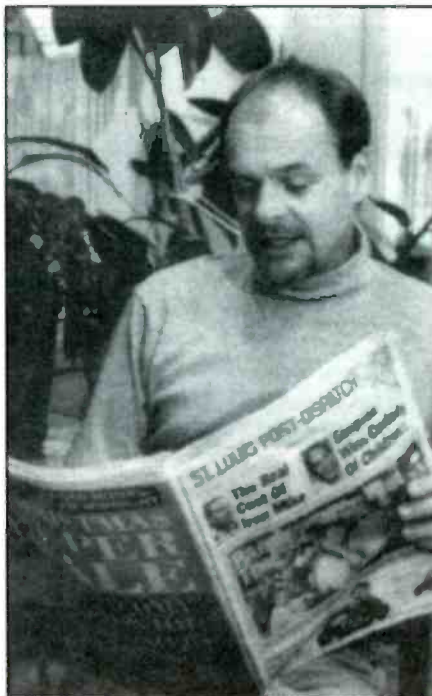

KMOX afternoon host Charles Jaco likes the new, tabloid format of the St. Louis Post-Dispatch. But what does he think of the new format of rival KSD-AM?

press time called for most WIBV programming and on-air personalities—including KMOX alumni Bill Wilkerson, Wendy Wiese, Kevin Horigan and John

Carney—to move down the dial to KSD-AM on Jan. 27. Rams football, meanwhile, will move KSD-FM and KFNS, and WIBV is expected to revamp with a format of syndicated and local talk.

Public Service

Virginia has always given us its best, among them eight presidents, and Arthur Ashe, Warren Beatty, Ella Fitzgerald, Shirley MacLaine, George C. Scott and Tom Wolfe. And for DXers, it's also the state that produced WRVA.

From day one, Nov. 2, 1925, WRVA strove to be the best. Unlike most stations at the time, which began as home-brew experiments, WRVA was a class act from its debut. Founder Larus Reed ordered a complete, 1 kW station from Western Electric, the most powerful set-up commercially available. Fueled by the public's fervor for radio, close ties to the community and even a newspaper headline advising "Crystal Set to Bedspring Will Bring in WRVA," the station quickly became an institution in Virginia. Reed's dedication speech included the promise that "service is going to be our motto."

Programming staples included live performances by orchestras, glee clubs and other talent from around the state and North Carolina, often via live remotes. Popular programs included the variety



Biddeford, Maine's WCYY can be found at 94.3 MHz and, thanks to sister station WCYI, also at 93.9 MHz. (Courtesy Bob Gilbert, Portland, ME)

Tim Timberlake
10:00 - 12:00 Noon
Also Traffic Reporter

Alden Ainsworth
6:00 - 10:00 A.M.

Lou Dean
11:15 P.M. - 5:00 A.M.

Bob Corry
2:00 - 6:00 P.M.

Bob Riddle
6:30 - 10:00 P.M.

Larry Dodd
OPEN FOR OPINION
12:35 - 2:00 P.M.

where your friends are . . .

Versatile and diversified, WRVA's popular air personalities entertain 24 hours a day. Musical moods are many and varied, punctuated with interesting conversation, information and entertainment.

WRVA . . . all the radio station you'll ever need.

Six stars of the WRVA lineup in 1975. (Courtesy G. Stewart Tyler, WA4JUO, Suffolk, VA)

show "Corn Cob Pipe Club," "Bridge by Radio" and recipes and household hints from "Aunt Sammy," while "The Sunshine Hour" provided hymns to shut-ins.

WRVA continued to grow in the '30s, adding in 1935 the first all-wood self-supporting antenna tower in North America, at 326 feet, and powering up to its current 50 kW in 1939. Following the attack on Pearl Harbor, WRVA devised a system to keep listeners abreast of developments throughout World War II. Between newscasts, an alarm clock was placed before an open microphone, with the bell signaling

"Unlike most stations at the time, which began as home-brew experiments, WRVA was a class act from its debut."

important news. The station also interviewed and entertained troops at military bases throughout the state, a service it performed again during the Korean war.

Twenty four-hour broadcasts began in 1949 with the "All Night Round-Up Music Show," hosted by Sam Workman. As their programming expanded, so, too, did the stations public service. The "Green Christmas" fund drive raised \$45,000 for the Crippled Children's Hospital, while high school seniors had the chance to win college scholarships through the University of Richmond/WRVA Scholarship Quiz program. Over the course of the next two decades, listeners would donate everything from money to buy new shoes for poor children, to used cars for flood victims.

Today, WRVA remains one of the highest-rated stations in the Richmond market,

with a nighttime signal that blankets much of the United States. Its sister stations include WRVH, WRVQ and WRXL.

East End

Singer/songwriter Paul Simon has pulled out of the radio business after 15 years as part owner of a Long Island station. Simon, along with brother and co-owner Eddie Simon and Saturday Night Live producer Lorne Michaels, have sold Hampton Bay's WWHB-FM. It was "the right time, the right buyer and the right deal," the group's lawyer told the New York Post in an article sent in by Bob Gilbert, of Portland, ME. The 3 kW station—which has simulcast New York City's WNEW-FM since 1990—fetched a reported \$6 million. WWHB's new owner, Odyssey Communications, said the station would continue with a rock format, although the simulcasting agreement with WNEW ended when the station changed hands.

The sale leaves Billy Joel as the only other singer/songwriter as part owner of a Long Island station. Joel, along with Sony exec Mickey Schulhof and Martha Stewart's lawyer, Leonard Ackerman,

Great Books!

Radio Monitoring

The How-To Guide T.J. "Skip" Arey
NEW for 1997 WB2GHA

The complete hands-on guide to the world of communications, including mediumwave, shortwave, VHF/UHF scanning, and much more! Find out who's listening, how they do it, what equipment "works." The #1 book in scanning and monitoring today!

"...covers it all, from DC to daylight."

NEW! World Scanner Report

ISBN 1-56866-101-0 344 pages, \$19.95

ULTIMATE SCANNER

Bill Cheek
Scanner modifications - THREE 240 pages, large format, \$29.95

Bill Cheek is the master of scanner modification, as Editor of the World Scanning Report and author of Scanner Modification Manuals.

SCANNERS & Secret Frequencies

Henry Eisenson
320 pages, \$19.95

"Must reading." Electronics Now "Useful, knowledgeable..." PopComm
"A giant undertaking... authoritative." Monitoring Times "You can't miss!" ASG
"Absolutely the best..." Norm Schran "A high point!" RCMA

Beyond Scanning!

Underground Database 100 pages, large
Everything that's sort of legal. "Fascinating" ASG format, \$23.75

Television GRAY Market

Henry Eisenson
Cable & satellite chips, descramblers, etc. 160 pages, \$23.75

"Explores this shadowy fringe area in depth... good info." PopComm

www.electriciti.com/~ipgbooks

INDEX Publishing Group, Inc. s/h \$4 1st book, then \$2 ea. CA add tax
3368 Governor Drive, Suite 273P MO/check via mail, or
San Diego, CA 92122 MCard, Visa, Amex
800-546-6707

CIRCLE 73 ON READER SERVICE CARD

Seeking Permit to Construct New AM Station

CO	Colona	1450 kHz	1 kW
Seeking Permits to Construct New FM Stations			
AR	Des Arc	91.7	64 kW
AR	Hatfield	104.1	
AR	Lakeview	93.5	
CA	Chester	99.7	
CA	McCloud	95.5	
CA	Weaverville	103.1	
CA	Willows	106.3	
CO	Colorado Springs	104.5	(KYZX-FM booster)
CO	Yuma	100.9	
GA	Americus	89.3	11 kW
GA	Douglas	89.3	25 kW
GA	Dublin	88.3	1 kW
GA	Waycross	91.9	1 kW
ID	Island Park	106.5	
IL	Macomb	95.9	
IN	Marengo	89.9	1 kW
KS	Larned	106.9	
KY	Hopkinsville	97.5	
LA	Arcadia	92.5	
LA	Gibbsland	104.5	
LA	Jonesboro	88.5	
ME	Milbridge	93.7	
MN	Fairbault	107.5	
MO	Otterville	107.7	
MO	Van Buren	91.3	100 kW
MO	Wheeling	105.9	
MS	Laurel	90.7	350 watts
MS	Oxford	105.1	
MS	Pontotoc	91.5	2.4 kW
MS	State College	104.5	
MT	Sidney	93.1	
NC	Beaufort	88.5	1 kW
NC	Williston	98.5	
NE	Albion	92.7	
NH	Jackson	99.5	
NM	Chama	98.9	
NM	Clovis	101.5	
NM	Grants	105.5	
NM	Santa Rosa	95.9	
NV	Wendover	102.3	
NY	Hague	93.7	
OK	Durant	91.1	1 kW
OK	Coalgate	105.5	
OK	Weatherford	90.5	1 kW
OR	Tillamook	94.1	
SD	Redfield	97.7	
TN	Lake City	90.7	135 watts
TX	Big Lake	98.3	
TX	Big Spring	91.5	250 watts
TX	Brazos	87.9	Experimental
TX	Brownfield	104.3	
TX	Cameron	94.3	
TX	Del Rio	89.9	1 kW
TX	Longview	91.7	1.3 kW
TX	New Ulm	92.3	
TX	Victoria	88.5	1 kW
WY	Gillette	91.9	

Granted Permits to Construct New FM Stations

AR	Ola	101.3	850 watts
CO	Brush	106.3	2 kW
IA	Lamoni	97.9	21 kW
IL	Canton	101.1	6 kW
KS	Copeland	103.9	100 kW
KS	Independence	91.9	
KY	Louisville	91.9	6.8 kW
LA	De Ridder	92.1	12.2 kW
MP	Garapan, Siapan	101.1	3.2 kW
MT	Big Sky	104.5	
NC	Biltmore Forest	96.5	280 watts
NE	Hubbard	91.3	
NH	Lancaster	102.3	360 watts
NJ	Cape May	89.1	50 kW
NV	Pioche	98.9	
OK	Snyder	100.3	2.1 kW
OR	Cherryville	88.7	
OR	Seaside	98.9	6 kW (reinstated)
TX	Ingram	90.1	50 kW
WY	Cheyenne	104.9	6 kW

Canceled

KAEI	Wishek, SD	92.3	100 kW
WAIY	Fairbury, IL	107.7	6 kW
WAKJ	Defuniak Springs	91.3	300 watts

Revoked

KLEH	Anamosa, IA	1290 kHz	500 watts
WSJR	Madawaska, ME	1230 kHz	1 kW

Ordered to Show Cause Why License Should Not Be Revoked

KHUD	Port Neches, TX	1150 kHz	Dark and other reasons
KZAL	Desert Center, CA	105.5 MHz	Dark and other reasons
WNEX	Macon, Georgia	1400 kHz	Dark since '95 or before

Requesting Changed AM Facilities

KHTX	Salinas, CA	1460 kHz	Seeks increase to 10 kW
KVCI	Mineola, TX	1510 kHz	Seeks move to Canton, 500/400 watts
WAMO	Pittsburgh, PA	860 kHz	Seeks move to Milvale
WUSS	Atlantic City, NJ	1490 kHz	Seeks move to Pleasantville 290 watts

Changed AM Facilities

WHFB	Benton Harbor, MI	1060 kHz	Added night service
WMYQ	Newton, MS	1410 kHz	Changed frequency

Requesting Changed FM Frequencies

WSLX	New Canaan, CT	91.9	Seeks move to 102.3 MHz
WVYC	York, PA	88.1	Seeks move to 99.7 MHz, 360 watts

Changed FM Frequencies

KULE-FM	Ephrata, WA	95.9	Changed to 92.3 MHz, 20 kW
WGHR	Marietta, GA	100.7	Changed frequency

Pending AM Call Letter Changes

New	Old	
KIHM	KIRS	Sun Valley, NV
KKMS	KEGE	Richfield, MN
KMRZ	KUUY	Orchard Valley, WY
WPGR	WDSY	Pittsburgh, PA
WXTO	WACC	Hialeah, FL

Changed AM Call Letters

New	Old	
KBCR	KSBT	Steamboat Springs, CO
KDIZ	KRRS	Golden Valley, MN
KSHP	KKDD	N. Las Vegas, NV
KXTK	KREW-FM	Des Moines, IA
WADB	WJLK	Asbury Park, NJ
WDIZ	WGNE	Panama City, FL
WJNA	WYFX	Boynton Beach, FL
WLVM	WMIY	Fairview, NC
WMHG	WSFM	Muskegon, MI
WOKU	WVKH	Hurricane, WV
WRNJ	WRVH	Hackettstown, NJ
WTRX	WDPA	Toocoo Falls, GA
WVNZ	WTMM	Richmond, VA
WYFX	WIRA	Fort Pierce, FL

New AM Call Letters Issued

WAIU Hackettstown, NJ

New FM Call Letters Issued

KARF	Independence, KS
KARG	Poteau, OK
KKOS	Palacios, TX
KRBW	Ottawa, KS
KUJ-FM	Walla Walla, WA
WVAB	Clarkston, WA
WAQJ	Crystal Falls, MI
WAQL	McComb, MS
WAQM	Cambridge Springs, PA
WLVG	Center Moriches, NY

WWLC
WZKZ

Balsam Lake, WI
Alfred, NY

Changed FM Call Letters

New	Old	
KBBB	KBKO-FM	Billings, MT
KBCR-FM	KBCR	Steamboat Springs, CO
KCDU	KAXT	Hollister, CA
KFGY	KLCQ	Healdsburg, CA
KHHK	KYKA	Neches, WA
KISE	KJMY	Seaside, CA
KIXK	KRMR	Ketchum, ID
KJJZ	KLCX	Indio, CA
KLDQ-FM	KFMK	Winton, CA
KLHB	KKHQ	Odem, TX
KNOS	KAQB	Omaha, NE
KQDJ-FM	KOVQ-FM	Valley City, ND
KRBR	KZIO	Superior, WI
KRME	KZBA	Shafter, CA
KRNQ	KYAT	Keokuk, IA
KRUF	KWKH-FM	Shreveport, LA
KSJM	KTSS	Oro Valley, AZ
KVGO	KNFX-FM	Spring Valley, MN
KXFG	KWXH	Sun Valley, CA
KXGT	KYNU	Jamestown, ND
KZTB	KREW-FM	Sunnyside, WA
WCNK	WSFN	Key West, FL
WEMX	WYCT	Kentwood, LA
WGKC	WHZT	Indio, CA
WHRR	WVZD	Dennysville, ME
WJCP	WJLR	Austin, IN
WJZT	WTPS	Midway, FL
WOWW	WMTO	Port Saint Joe, FL
WPKQ	WZPK	Berlin, NH
WQRV	WHRR	Avon, NY
WRFM	WAIU	Remsen, NY
WSHF	WEBZ	Mexico Beach, FL
WSHZ	WMHG	Muskegon, MI
WSOH	WJYL	New Washington, IN
WTGZ	WBIL-FM	Tuskegee, AL
WTRX	WDPA	Toocoo Falls, GA
WUUS	WKBG	Martinez, GA
WWBR	WDZR	Mount Clemens, MI
WWRZ	WKGF-FM	Arcadia, FL
WYCL	WOWW	Pensacola, FL

"The sale leaves Billy Joel as the only other singer/songwriter as part owner of a Long Island station."

own East Hampton's WEHM. Meanwhile, Arnold Schwarzenegger's brother-in-law, Robert Shriver, owns WBEA, in nearby Montauk.

In Brief

Washington, D.C.'s WTOP-AM may end its decades-old affiliation with CBS Radio News following the network's decision to close its Radio Stations News Service headquarters there. The 50 kW all-news station is continuing its negoti-

ations with CBS, but is also considering network news offerings from ABC, CNN and Westwood One.

Dick Cavett is the latest TV personality to try his hand at radio, with the Jan. 6 nationwide debut of The Dick Cavett Show. The syndicated weekday morning-drive show will feature social and political topics, as well as celebrity interviews.

Veteran radio talk-show host Barry Gray, whose 35-year stint at New York City's WMCA-AM included interviews with Harry Truman and Frank Sinatra,

died Dec. 21. He was 80. Gray was named Talk Show Host of the Year in 1996 by the National Association of Radio Talk Show Hosts.

Thanks

A special tip of the hat to G. Stewart Tyler, WA4JUO, of Suffolk, VA for providing a booklet on WRVA's history, produced by the station for its 50th anniversary in 1975. Your news clippings, bumper stickers, station and shack photos and QSLs are always welcome, as are your questions and comments. Send 'em to "Broadcast DXing" at Pop'Comm's Hicksville address. Until next month, 73.

Product Spotlight

POP'COMM REVIEWS PRODUCTS OF INTEREST

The Lowe SRX100 Receiver

Unpacking Lowe's new SRX100 receiver was a pleasant surprise. I didn't expect to find such a tiny package! It was really hard to imagine that this was a full-fledged communications receiver with continuous multimode coverage from 30 kHz to 30 MHz. I was anxious to give Lowe's latest addition a good run.

Front Panel and Controls

The front panel is rather Spartan in appearance, being uncluttered with few controls. The mode (AM, LSB or USB), frequency display and S-meter are presented on a generously sized LCD panel. The five-digit readout for frequency is to the nearest kHz, and the display numerals are about one-half inch high for easy viewing. The SRX100's S-meter was a small disappointment. It is a nine-segment bargraph across the lower portion of the LCD panel. I haven't fully adapted to these newfangled digital-type signal-strength displays. The LCD panel is not backlit, but I understand that the manufacturer is considering adding this feature.

Main Tuning

Tuning the bands with main tuning control is a delight. The knob is amply proportioned considering the diminutive packaging. The tuning had an unexpected and surprising feel. It was like I was driving a Mercedes through the shortwave bands! Popping the covers revealed the secret—there is a rather substantial metal flywheel connected to the other end of the tuning knob shaft! The main tuning knob also sports a small "finger dimple" to aid slow tuning.

One other thing you can't see—without prying into the hidden recesses of the receiver as I did—is that the main tuning knob is recessed into the front panel. There the knob is segmented into 10 sec-



The front panel is spartan, but functional. As you can see, the Lowe SRX100 front panel is clean and uncluttered.

Lowe SRX100 Receiver

Available from:	Electronic Distributors 325 Mill Street Vienna, VA 22180 (U.S. Importer)
Phone:	703-938-8105 or
Fax:	703-938-4525
Suggested Retail Price:	\$259.95

tions. It's part of the optical shaft encoder that provides the tuning information to the microprocessor. The Lowe receiver tunes in 1 kHz steps; each complete revolution of the knob yields a 10 kHz change in frequency.

Tuning Rates

There are no controls for setting the tuning rate, or for MHz frequency changes. With a 10 kHz per revolution tuning rate, going from the AM BCB to the upper reaches of the SW coverage would be a tedious task indeed. But this problem is cleverly handled by an automatic four-step tuning rate—the receiver will tune in either 1 kHz, 10 kHz, 100 kHz or 1 MHz steps, as determined by the

speed of the tuning knob's revolutions. All of this is automatically sensed by the microprocessor program.

The variable rate tuning does take some getting used to. Becoming impatient and tuning too fast will quickly reward you with a frequency far removed from where you intended to be. I quickly mastered the art of getting from "here" to "there" on the bands in short order. The receiver does not "rollover" when the band limits are reached. At the 30 MHz or 30 kHz tuning limits, the receiver stops and you have to reverse tuning direction.

Besides the main tuning knob, the only other linear controls are for the volume control and clarifier tuning knobs. A row of four push-buttons control mode selection in an up/down fashion, and memory store and recall. More on these later.

AM Reception

For the AM mode, the receiver bandwidth is fitted with a 6 kHz BW ceramic filter in the second IF stages. The filter has good skirt selectivity, and the stop-band characteristics are in part enhanced by being cascaded with those of the 15 kHz BW 2-pole crystal filter used at the 45 MHz first IF.

The AM detector uses a MC1496 balanced demodulator IC in a "semi-synchronous" detector. I wasn't able to dig up much technical info on how the Lowe AM detector works, but I can report that AM reception is clean sounding with good audio recovery on weak signals or those with fading. AM AGC performance is good.

The SRX100 sports an internal 4-inch speaker under the top cover for ample audio and reasonable fidelity. There is no tone control. An external speaker, headphones or audio processor maybe attached via a jack on the receiver's rear panel.

SSB Reception

The SRX100 will receive either upper or lower SSB signals. The two mode-selector push-buttons allow the user to

"The tuning had an unexpected and surprising feel. It was like I was driving a Mercedes through the shortwave bands!"

scroll up or down through the AM, LSB or USB modes. The selected mode is indicated on the LCD panel.

Tuning SSB signals is difficult because of the minimum 1 kHz tuning steps and relatively broad IF filtering. SSB signals are fine tuned until they become intelligible using the clarifier control. The clarifier control allows a plus-or-minus 800 Hz tuning range.

I always found myself making several tries at the main tuning before being able to satisfactorily resolve the clarifier fine tuning. Going between the USB and LSB modes results in a 4 kHz carrier shift—again making tuning a pain. The frequency display does not reflect clarifier tuning. The displayed frequency also does not correct for the plus or minus 2 kHz carrier frequency offset in the SSB modes. This is a minor annoyance, and could have been compensated for in the receiver's programming.

SSB Filter

A 3.8 kHz bandwidth filter is selected when either the USB or LSB modes are selected. The 3.8 kHz filter is adequate for casual monitoring. While stations seemed more natural sounding than what a narrower filter would allow, the filtering is a tad wide for SSB reception. Note that the SSB mode is not included on the new comparably priced Drake SW1 receiver.

Audio recovery on SSB is also clean sounding, and uses the MC1496 as a product detector in that mode. SSB AGC action is good except for some occasional AGC overshoot. I noted a slight wavering of the beat tone when monitoring a steady carrier—this most likely results from an engineering trade-off of synthesizer stability to obtain rapid frequency agility in this single-loop design.

A Missed Opportunity

The 3.8 kHz SSB filter would have been an ideal alternate filter choice for AM reception. This could have been done with a fourth mode selection, giving the user choices of either AM-Wide or AM-Narrow filtering. Even a rear panel selector switch would have served here. With the 10- or 9-kHz station spacing used on

“... the receiver's strong-signal handling abilities, price class, and simplicity makes the SRX100 a good starter set.”

the AM broadcast bands, the 6 kHz filter is fine. But shortwave stations are assigned in 5 kHz channel steps—separating a weak signal from a neighboring adjacent channel powerhog would be easier using the narrow 3.8 kHz filter. You can get by by using the SSB mode for SW reception, and zero-beating the desired station. For example, if a station higher in frequency is causing bleedover, going to LSB should give noticeable relief.

One Memory Channel

The receiver has one, yes, count 'em, *one* memory channel. The memory can be used to store your favorite frequency. It also determines the power up frequency for the radio. Mode selection is not stored in memory; the radio powers up in the AM mode.

A Communications Receiver or a Radio?

There are many entry level receivers for the novice SWL to choose from. Beginners are often swayed by “bells and whistles”—multiple timers, hundreds of memory channels and the number of push buttons and knobs on the front panel. Alas, while it's easy to manufacture a pretty package with endless frills, designing a strong receiver frontend is costly and usually unappreciated by most consumers. The “bells and whistles” are nice to have, and for some SWLs an absolute necessity, but they should not be the sole criteria for selecting an HF receiver.

Good RF Performance

This is where, for its price class, the SRX100 shines. The receiver frontend uses a discrete component Gilbert cell mixer employing four bipolar transistors and two JFETs for good dynamic range.

The ferrite core of the input balun is massive! This is needed for the multi-octave coverage; the large size also prevents core saturation and IMD generation in the presence of strong signals.

There is no RF amplifier, nor is one needed—receiver noise floor is under the normal HF atmospheric noise. There is no bandpass filtering in the receiver frontend, either. Users living near strong SW or BCB stations, or those with large-sized outdoor antennas, may benefit from an external preselector.

Other Technical Notes

The receiver is dual conversion, using upconversion to a first IF at 45 MHz. This puts all of the image frequencies where they belong—well out of the tuning range of the receiver! A two-pole 45 MHz monolithic filter with a 15 kHz BW is used here. A good first IF filter is important, it protects the second mixer from strong off-frequency signals that could cause IMD problems. As mentioned before, the second IF is at 455 kHz.

The synthesizer is a single-loop design. A small 20-pin microprocessor is the brains of the outfit. It interprets the shaft encoder and pushbutton data entries, and computes the necessary ser-

PAY TV AND SATELLITE DESCRAMBLING
all new information 1996 Edition VOLUME 7
Pay TV and Satellite Descrambling Volume 1-7 (all different),
Satellite & DBS hacking, Wireless Cable Hacking, Complete
Wizard, Buying Surplus, Seized & Distressed Goods, Cellular
Phone Hacking, Computer & Phone Hacking, all new Hacker
Video. \$15.95 each, any 3/\$34.95 or any 5/\$52.95. American
Hacker Magazine \$29.95 includes BBS. Our Best Deal is
everything listed here and lots more for only \$129.95. New
product catalog \$1. Add \$6 for C.O. D. S.
SCRAMBLING NEWS
3494 DELAWARE AVE., #123, BUFFALO, NY 14217-1230
Voice/FAX (716) 283-6910 BBS (716) 871-1915
<http://www.scramblingnews.com>
CIRCLE 85 ON READER SERVICE CARD

Windows Control of Icom Radios
NEW See and Hear the difference !!!
Powerful, high speed scanning control with more features! High res.
graphics let you see what's happening in real time. Search, sort, scan
by frequency, comments, hit times, modes etc. PC can even SPEAK
the frequency / hit time! All features can be set by channel. Intelligent
tape control and delays. Call for demo and more information! VISA-MC
\$225 + S/H Includes Interface with Tape Control. Win 3.1 or 95
FUTURE SCANNING SYSTEMS
6105 SE Nowata Road Unit 6, Bartlesville, OK 74006
TEL 918-335-3318 FAX 918-335-3328

NEW CODE READERS From \$149
Copy Morse Code From Your Receiver!
No Computer Hookup or TNC Needed!
Tune in to coded shortwave signals. Listen in
to interesting amateur, commercial, military,
exotic and secret code from all over the world.
**Break the code barrier! Learn
CW. Copy RTTY & ASCII too!**



Power Supply Included FREE!
CODE SCANNER - Compact, light weight reader
32 character LCD. Wired...\$179 S&H \$6
CODE BREAKER - Sleek design. 8 Large LEDs.
Great code tutor too. (Option: PC serial port.)
Wired...\$149 Wired Port...\$29 S&H \$6
Free Brochure. Call-Write-Order. MC/VISA.
Microcraft Corporation
Box 513PC, Thiensville, WI 53092
Phone (414) 241-8144
CIRCLE 78 ON READER SERVICE CARD

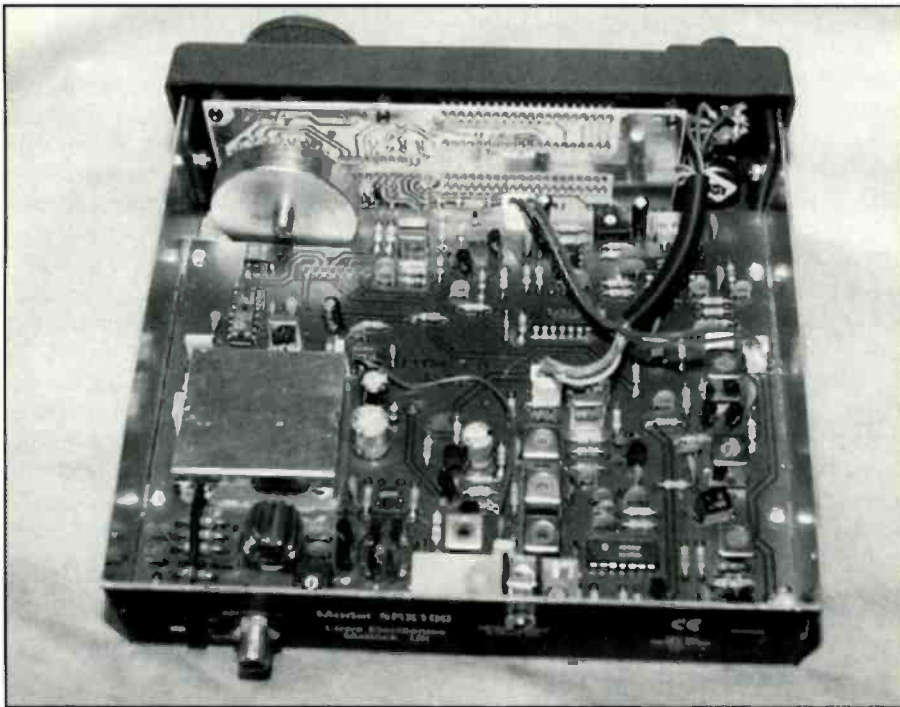

Peeking inside the Lowe 100SRX shows the clean layout. Note the large tuning flywheel, and massive input balun.

ial data stream to the synthesizer chip and also the data to the LCD display driver chip. The synthesizer works in 1 kHz steps, which determines the minimal tuning steps.

Lab Tests

I noted some reciprocal mixing when I generated a strong off-channel signal out of the first IF's passband. I could hear noise products on 7000 kHz with the generator producing a strong 1 μ V signal which was on 7030 kHz. Stronger signal levels caused some problems up to one or two MHz away. This was not unexpected from such a basic synthesizer scheme, and is known to cause problems when strong signals are present. This sounds like very noisy background garbage when tuned to an unused frequency. This problem also makes the advantages of retrofitting sharper filters at a later date questionable.

The receiver MDS was about .3 μ V at 7 MHz. I then set up two signal generators, one on 7100 kHz and the other on 7050 kHz through a combiner into the receiver antenna jack. I steadily increased the generator levels until third-order IMD products were audible on 7150 kHz and 7000 kHz. My measurements show a dynamic range of about 76 dB.

AM and sideband signals are detectable well below the 1 μ V level.

SWLing With the SRX100

An attenuator (rear panel switch) is available if strong signals overload the radio. The attenuator provides 10dB of attenuation. I never needed to use the attenuator, but it is useful to bring signals on the AM BCB down to a level where the S-meter bargraph isn't continuously at full scale, or for nighttime SWLing when signals are strong.

Each S-meter bargraph segment roughly represents a 3 dB change in signal strength. The majority of my monitoring was done on my 150 foot longwire. Located high and in the clear, this antenna can deliver some pretty potent signal levels to a receiver. Despite this, the Lowe receiver remained well behaved. For monitoring below 15 MHz on the longwire antenna, I usually left the 10dB attenuator inline.

MLF performance was not fully evaluated—a loop or active antenna is needed for best reception under 500 kHz and I did not have one on hand. A short indoor wire antenna is supplied with the radio. It works, but for best performance and freedom from electrical noise I suggest you run a 30 or 40-foot longwire outdoors.

The receiver is constructed on two glass epoxy pc boards. The main board contains most of the RF, audio and synthesizer circuits; a smaller board is locat-

ed behind the front panel and mainly deals with the microprocessor, digital display driver, shaft encoder and panel controls. There are no surface-mount parts, and with the exception of the microprocessor, most of the electrical components are commonly available. Board layouts are clean and uncluttered. The receiver is well-made and reflects well on its English heritage.

Minor Quibbles

I already mentioned the lack of back-lighting on the LCD panel. Another minor inconvenience was the lack of a tilt bail, or provisions for a mounting bracket for under shelf mounting. The review unit was propped up by a handy spool of solder so I could see the front panel.

I remain bemused by the one memory channel. Why not include at least 10?

Requires External Power

The receiver requires an external regulated 12 Vdc power source. A wall-plug transformer is supplied. The radio may be run from any 12 Vdc supply capable of handling 300 mA. I measured the receiver current draw at 280 mA on a 12 volt lab supply. I found the power source must be well filtered and regulated, otherwise SSB reception will be severely degraded.

The radio has internal reverse-polarity idiot diode protection, but no internal fuse. If you make up your own power cord you must supply an inline 1/2 amp fuse!

Final Observations on the SRX100

I will let you in on a little trade secret—the receiver is made by AKD in England, and is sold and advertised there as the Target HF 3. It is exported to the USA under the Lowe banner as the SRX100. The receiver is worthy of carrying the Lowe badge. Yes, this receiver is short on the "bell-and-whistles" or the operating conveniences found on other comparable units. But the receiver's strong-signal handling abilities, price class, and simplicity makes the SRX100 a good starter set.

Receiver designers usually start with a market target price and build as best a receiver as they can within those guidelines. If this radio had a street price of \$500 this would be considered a very negative review. The Lowe SRX100, however, strikes a fair balance between performance and price. ■

The ACARS Downlink

BY BOB EVANS

YOUR LINK TO DIGITAL AIRCRAFT COMMUNICATIONS

A Potpourri of ACARS Items!

Our column this month contains a potpourri of items, from onboard system-generated downlinks, to aircraft performance data to a very drunk Russian.

Avionic Subsystem Downlinks

The Message Sequence Number normally contains a four digit number that represents the time in minutes and seconds (MMSS) past the hour that the message was sent (43 minutes, 19 seconds in the example below) is an Avionic Sybsystem Downlink.

ACARS mode: 2 Aircraft reg: .C-FMES
Message label: Q0 Block id: 0 Msg. no: 4319
Flight id: CP0962

You have probably also observed values such as M01A, D29B or F15C. Avionic subsystems on board the aircraft can now automatically downlink messages that also indicate the subsystem that originated with them.

ACARS mode: 2 Aircraft reg: .N518US
Message label: 39 Block id: 3 Msg. no: M80A
(from Management Unit)
Flight id: NW0257
Message content:-
231139 YYZ DTW1
1208 N

ACARS mode: 2 Aircraft reg: .PH-MCR
Message label: H1 Block id: 4 Msg. no: C001 (from CFDIU)
Flight id: MP6470
Message content:-
#CFB
DEU-2 FAULTS
CODE NO. 310003
BTMTP
DEU-2
DEU-3 FAULTS
CODE NO. 310003
BTMTP
DEU-3
EEC1A FAULTS
CODE NO. 735222
352-22 TT3 SIGNAL

ACARS mode: 2 Aircraft reg: .N152UA
Message label: Q0 Block id: 3 Msg. no: S90A
(from MU System Control)
Flight id: UA0800

ARINC's protocol is as follows:

- 1 letter code indicating the subsystem
- 2 character message number (00-99)
- 1 character Block Sequence Character (A-Z)

The first block of a new avionics downlink always starts with the BCS character "A". I have also noted that sometimes the BCS character is also a digit, as in:

ACARS mode: 2 Aircraft reg: .N301AA
Message label: H1 Block id: 4 Msg. no: D443 (note BCS ends in "3")
Flight id: AA0000

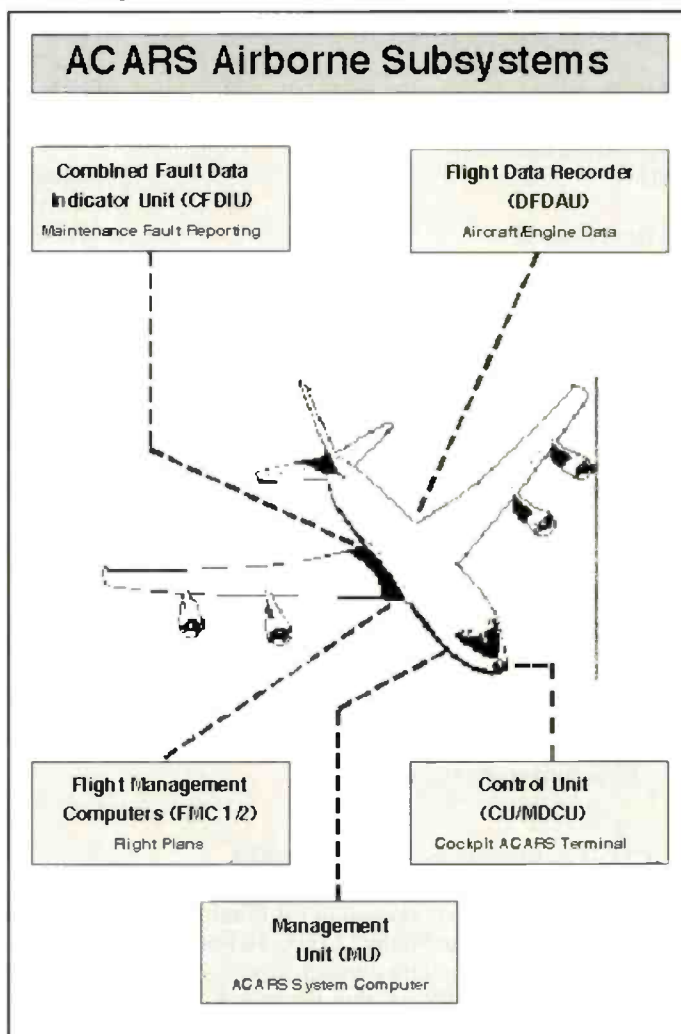

Message content:-

#DFBEDA/E1407,496,337.E7D,,5B95C4,5E45F0,528537,27E293,04003D,105
090,2EB268,1200
CA,10031040,2DE,0C20C4,007,001,0,46244B,183221

The following is a list of valid subsystem codes. To date, I have logged "C, D, F, M, and S". I have also logged a few "A's which I believe are also related to the DFDAU.

ACARS mode: 2 Aircraft reg: .N321DL

Message label: H1 Block id: 3 Msg. no: A001 (note "A" prefix)

Flight id: DL0699

Message content:-

#DFB*ENG208569258349761M212M4750843084844364572025700266208600860
1061084946
P043P0420 000 11 19221933098111 1 11

UNIT ID	CODE	REMARKS
CFDIU	C	Combined Fault Data Indicator Unit (Maintenance Fault Reporting)
DFDAU	D	Digital Flight Data Acquisition Recorder (Flight Data Recorder) (Engine and/or Aircraft Performance) (ACMS, ADAS,
AIDS)		
FMC 1	F	Flight Management Computer #1 (left side) (Flight Plans)(FMS, FMGC, FMGEC)
FMC 2	F	Flight Management Computer #2 (right side) (Same as FMC 1)
MU (ATS Functions)	L	
MU	M	Management Unit (ACARS Communications Manager)
System Control	S	MU System Control Functions
OAT	O	Optional Auxiliary Terminal
Cabin Terminal 1	1	
Cabin Terminal 2	2	
Cabin Terminal 3	3	
Cabin Terminal 4	4	
User Defined	U	
EICAS/ECAM/EFIS	E	Instrumentation Reporting Systems (EICAS, ECAM, EFIS)
SDU (1 and 2)	Q	Satellite Data Unit
ATSU/ADSU	J	Air Traffic Service Application Software

Note that there is direct relationship between the Downlink Avionics subsystem code and the first four characters of the message.

First line of message text always starts with "#"

Next two characters represent originating unit

CF = CFDIU, DF = DFDAU, M1 = FMC 1, M2 = FMC 2

According to ARINC last letter indicates mode:

"A" = conventional mode

"B" = conversational mode

CFDIU—Maintenance Fault Examples

#CF = Maintenance Fault

WRN = Warning as opposed to FR (Fault Report)

Warning Date/Time 96/09/22 UTC 10 hours 47 minutes 00 seconds 21 (sub-seconds)

310006 generic warning number, covers warnings of similar nature.

CAB PR LO DIF PR = Cabin Pressure Low-Difference in pressure

ACARS mode: 2 Aircraft reg: .C-GVXB

Message label: H1 Block id: 3 Msg. no: C354

Flight id: 2T0543

Message content:-

#CFBWRN/WN96092210470021310006CAB PR LO DIFF PRXX

ACARS mode: 2 Aircraft reg: .C-GVXA
Message label: H1 Block id: 0 Msg. no: C498
Flight id: 2T0932
Message content:-
#CFBFLR/FR960922113600231100CHECK HF-1 ANTENNA CIRCUIT/IDHF 1

Note specific fault number (FR 231100 CHECK HF-1 ANTENNA
CIRCUIT/IDHF 1

FMC Example:

#M1 indicates message originated by Flight Management Computer #1
If FMC #2 originated the message it would read "#M2"

ACARS mode: 2 Aircraft reg: .N654UA
Message label: H1 Block id: 4 Msg. no: F37A
Flight id: UA0934
Message content:-
#M1BPOSN44406W080128.YYZ13,081756,330,MSS14,084232,MSS15,M50,3372
0,787/TS0817
564C8D

DFDAU Example:

#DF (B)
EDA = Engine Data

ACARS mode: 2 Aircraft reg: .N1429G
Message label: H1 Block id: 3 Msg. no: D003
Flight id: AA0793
Message content:-
#DFBEDA/E1*CRZ-22091740-235-48834997750076560080004100005671
661660816081
308930893661063600208802024+024+024444506206000700700200302370108
001110000

Here are some further examples:

#CFBFLR or #CFBWRN Equipment Failures (Faults or Warnings)
#DFB*TKO or #DFBTKO Take Off Performance data
#DFB*CRZ or #DFBCRZ Cruise Performance data
#DFB*WOB or #DFBWOB Weather Observation
#DFB/PIREP Pilots Report
#DFBEDA or #DFBENG Engine Data
#M1AAEP Position/Weather report
#M2APWD Flight Plan Predicted Wind Data
#M1BREQPW1 Predicted wind info request

An Explanation

YZCN = Air Canada Datalink Network
YYZ1 = Toronto PIA Terminal 1
YYZ2 = Toronto PIA Terminal 2
13147 = Air Canada proprietary ACARS frequency 131.475
(note missing last digit—common practice for airband voice freqs)
092 = ACARS ground station (uplink transmitter id?) for YYZ2
105 = ACARS ground station (uplink transmitter id?) for YYZ1
(Note: these Id's are found in message uplinks—identifies the sender)
A-Z = repeated twice—dummy fill message text

Examples of Uplink Originators in Messages

1. Final Load Detail Message sent by 092(YYZ2) to AC0819 (C-FTLW) Fleet #722
(Aircraft type = DC9-32)

LBS signifies figures are in pounds, not kilos

ACARS mode: b Aircraft reg: .C-FTLW
Message label: 4M Block id: F Msg. no: -
Flight id:
Message content:-
-LDF M555 YYZOHAC 31AUG/1742 YYZ2 ACK C-FTLW/ /0819 09090763052
0819/31/YYZ/ORD/00
DLD AC819/31AUG YYZ/ORD
A/C 722 CFTLW DC9-32 /092 *LBS*

2. ACARS frequencies message sent by 105 (YYZ1)

ACARS mode: o Aircraft reg: .C-FSJF
Message label: 4C Block id: F Msg. no:
Flight id:
Message content:-
-MFT C365 105/CN131475Y/131550Y/XA131550Y/XS131725N/XS131550N/JD131450N

Obviously these are for Canada/US, Europe and Japan.

Squitter messages from the UK and Europe are less prolific, listing only the ground station code. (STN1 = Standford)

ACARS mode: q Aircraft reg:
Message label: SQ Block id: Msg. no: 00XS
Flight id: STN1

Engine and Performance Data

Downlink Message Label 5Z signifies and Airline Designated Downlink message. Many airlines, including North West (NW) and US Air (US) use this message format to report engine and aircraft performance. Before examining the messages themselves, a few definitions are in order:

Aircraft Weight—Total Aircraft Weight (lbs)
Flight Level—Aircraft's altitude, expressed in hundreds of feet
(e.g. FL 370 = 37,000 ft)
Indicated Air Speed—Aircraft's speed in knots
True Air Speed—Speed reading corrected for temperature and altitude (knots)
Mach #—Aircraft speed compared to speed of sound
Static Air Temperature—Outside air temperature (degrees C) corrected for compressibility effects (the leading edge of the temperature probe heats up at high speeds), also known as Outside Air Temperature (P = +, M = -)
Indicated Outside Air Temperature—Air temperature uncorrected for compressibility effects (also known as ram air temperature (degrees C) P = +, M = -)
EGT—Turbine Exhaust Gas Temperature
EPR—Ratio of engine output to input pressure (proportional to engine thrust)
Fuel Flow—Flow rate of fuel to engine (lbs per hour)
N1—Fan speed, usually expressed as a percentage of maximum rated rpm
N2—Compressor speed (% of maximum rpm)

Example:

ACARS mode: 2 Aircraft reg: .N925VJ
Message label: 5Z Block id: 6 Msg. no: 5705
Flight id: US0305
Message content:-
/ENG/0830/230/275/660/408/P02/M23/157/156/811/815/390/392/852/851
/2900/2900

/ENG Engine Data
/0830 Aircraft Weight 83,000 lbs
/230 Flight Level FL230 (20,300 ft)
/275 Indicated Airspeed 275 knots
/660 Mach .660

/408 True Air Speed 408 knots
 /P02 Indicated Outside Temperature + 2_ C
 /M23 True Outside Temperature—23_ C
 /157 EPR Engine 1 1.57
 /156 EPR Engine 2 1.56
 /811 N1 Engine 1 81.1%
 /815 N1 Engine 2 81.5%
 /390 EGT Engine 1 390_ C
 /392 EGT Engine 2 392_ C
 /852 N2 Engine 1 85.2%
 /851 N2 Engine 2 85.1%
 /2900 Fuel Flow Engine 1 2,900 lbs
 /2900 Fuel Flow Engine 2 2,900 lbs

Here's One for YOU to Decode:

ACARS mode: 2 Aircraft reg: .N793N
 Message label: 5Z Block id: 7 Msg. no: 0847
 Flight id: PI0243
 Message content:-
 /ENG/0895/370/230/716/417/M27/M50/194/195/827/827/434/428/827/863
 /2200/2300

Delta "INRANGE" Messages

Several airlines transmit "INRANG(E)" messages as they get close to their destination. Many of these messages contain requests for the various types of ground support services required to meet the flight. Although not used in these examples, you will often see the abbreviation "MAAS" which stands for "Meet and Assist".

ACARS mode: 2 Aircraft reg: .N730DA
 Message label: 80 Block id: 5 Msg. no: 3238
 Flight id: DL1424
 Message content:-
 3702 INRANG 1424/06 KSLC/KJFK .N730DA
 /CHR 05/MNR 02/RED N/MED N/SEC N/LNG N/LAV Y/CAB Y
 1 ELEC CRT

Here's a brief explanation of this message type:

DS Destination Station
 ERT Estimated Ramp Time
 CHR Wheel Chairs (number required or blank)
 MNR Unaccompanied minors (number or blank)
 RED Red Coat (Passenger Agent) required to meet flight Y/N
 MED Medical Assistance required Y/N
 SEC Security Assistance required Y/N
 LNG Language Interpreter required Y/N
 LAV Lavatory Servicing required Y/N
 CAB Cabin Servicing required Y/N

Additional comments—1 Electric Cart

And finally . . .

2 .N810DE 80 6 M23A DL0049
 3703/26 EDDF/KCVG .N810DE
 /DS KCVG/ERT 1956/CHR 02/MNR /RED Y/MED N/SEC N/LNG Y/LAV Y/CAB Y
 MOTHER/INFANT NEED SHOPPING CART TO HELP DE-PL + LUGGAGE.
 1 RDCOAT TO MEET VERY DRUNK RUSSIAN.

Until next time, good listening and 73, Bob.

Communications Confidential

YOUR GUIDE TO SHORTWAVE "UTILITY" STATIONS

Ships Electronic Systems Evaluation Facility Norfolk

Fellow Buckeye Steve Fisher (OH) was kind enough to stop and take a picture of the U.S. Navy facility SESEF Norfolk, Fort Story, VA, and send it in knowing what a Navy fan I am. SESEF is 'Ships Electronic Systems Evaluation Facility', where ships electronic systems, including HF radios, are tested along with other forms of electronic emitters. Steve found that indeed the SESEF facility is located on the U.S. Army's Ft. Story in Virginia Beach, VA. It is near the east gate of Ft. Story just off U.S. Route 60. To the right of the building are some sand dunes and just beyond the dunes is a beach and the Atlantic Ocean. To the left of the building is a large grass-covered mound with a steel door. Steve's father-in-law, who was along for the ride on this trip, was stationed nearby during the 1950's and seemed to recall at that time there was a large underground Nike missile plant at Ft. Story. This may have at one time been part of that. Fort Story is located at the southeastern entrance to the Chesapeake Bay and contains the famous Cape Henry Lighthouse.

The primary frequency is 7535.0 with the primary mode being USB. Other logged frequencies have been: 9050.0, 10315.0, 10711.0, 12315.0, 12930.0 (mentioned, never heard), and 18200.0 kHz. Listings from other publications or logs have also shown 4040.0, 4515.0, and 14645.0 kHz, but I have never been able to confirm these. Until the recent military draw-down, there was also a SESEF at Charleston, SC, heard infrequently on 9050.0, and also listed in other publications or logs on 7485.0 kHz. However that facility was reportedly closed and there have been no recent logs of it. Recently though, logs surfaced of "SESEF Mayport" (Florida). I have been able to log them several times on 7535.0 kHz. In fact, during recent HF testing of NNTR, the nuclear Nimitz-class aircraft carrier USS Theodore Roosevelt (CVN-71), SESEF Norfolk was having a hard time working the carrier, and SESEF Mayport took over the testing. But I have

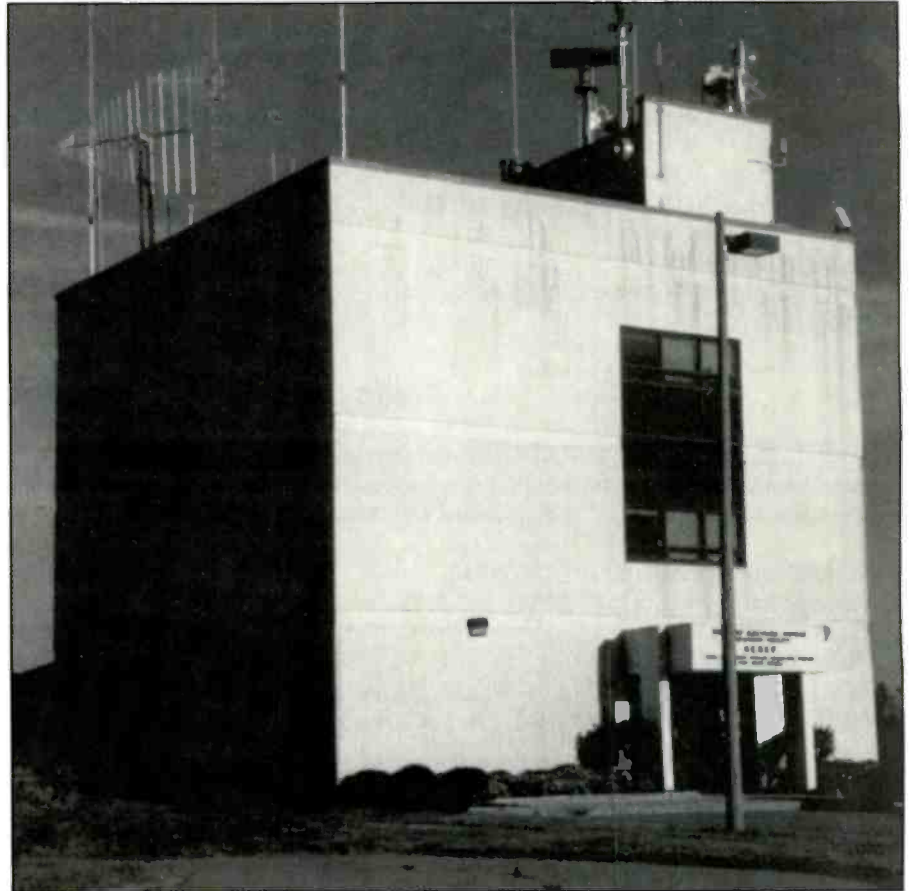

Photo of the U.S. Navy facility SESEF Norfolk, Ft. Story, VA, taken by Steve Fisher (OH).

yet to confirm this is a new permanent facility. In a QSL letter I received from SESEF Norfolk a few years back, they made mention that Norfolk was "one of but many small RF, EW, and Navigation Aids emitter evaluation and test facilities located near major Naval ports worldwide." That has always stuck with me as despite knowing a lot of utility fans worldwide. I have never seen this type of facility logged elsewhere. It would make sense to have an alike facility for the Pacific fleet, but the Navy Standard Distribution List (SDL) does not show any others under the Naval Sea Systems Command as Norfolk is. If anyone has further information, drop me a line.



SESEF patch sent to me with QSL letter several years ago.



DRDR

Unterseeboot U24 (S173)

THIS WILL VERIFY YOUR RECEPTION OF RADIO STATION
DRDR ABOARD *Unterseeboot U24 (S173)* ON 5TH APRIL 1996
AT 0027 UTC ON 6779.0 kHz

TRANSMITTER POWER: *100W*
ANTENNA: *12m*
VESSEL'S APPROX. LOCATION:
REMARKS: *Work on Paracop
Exact position is confidential*



PFC received by Jim Pogue, TN, from the German Navy submarine *Unterseeboot U-24 (S-173)*, International call sign "DRDR", heard on 6779.0 kHz.

If you want to try and hear some of these ship tests. SESEF Norfolk is a 1300 to 2100 UTC operation, so you have to listen during business hours. Most of the ships simply ID by name.

More Reader Mail

Longtime reader Costas Krallis, SV1XV, and Peter Bottis, SV1EEE, both from Athens, Greece wrote regarding the photograph on page 69 of this column in the November 1996 issue. They report that the building with the log periodic antenna on it is in fact the Greek Ministry of Foreign Affairs (MFA). The Egyptian Embassy is the lower building to the left, the taller building to the right is the Greek Parliament building. Thanks to both for the IDs.

Ace aero fan Tony Orr, who edits the Civil Aero column for the WUN Club, sent us an update on the new 5517.0 frequency recently reported. Tony reports that this appears to be a replacement for 5658.0 and the AFI-3 MWARA traffic that had been heard on that frequency. He was able to log the following stations recently: Addis Ababa, Asmara, Cairo, Entebbe, Khartoum, Mogadishu, Sanaa, and Tripoli.

Gary Seven from Brooklyn, NY, checks in via internet. Gary uses Grundig Satellit 700 to log numbers stations and sends his first contributions this month.

Another internet contribution came

from Kevin Scott in Lawrenceville, GA, a suburb of Atlanta. Kevin is a beacon fan and reports his best effort so far (as far as miles/watt) has been beacon DZM, Dumas, AR at 430 miles on 1/24/96. His furthest DX in mileage is Mercaderes, Columbia, beacon MER, on 1685 kHz at 2270 miles although it runs 1 kW.

Actually quite a few of you dropped me a line via e-mail, and I was pleased to hear from all; electronic and Mr. Postman alike. Some questions were asked by more than one person, so here is a quick summary. Question No. 1, "What does 'no joy' mean?". Simply, no luck, as in he didn't get through to the party he was calling. I was once told that the term comes from the past in amateur radio circles. If they couldn't make contact on the ham bands, it was said there was "no joy" in the shack that night. Now, I wouldn't bet the farm on that being the only source of the term, but I would bet someone out there will have the answer. In any case, the term is widely used by the U.S. military today. Question No. 2, "What does 'Volmet' mean?". Volmet is a French term for "flying meteo" or "flying weather". We have 'vol', which is French for 'flying' and 'met' from 'meteorologie' or the French word for meteorology which is the study of weather. Volmet's transmit aviation weather for pilots to monitor as they fly into an area. The specific frequencies relate to a particular flight area, such as the North Atlantic or NAT-VOL.

Although some times vary, try listening on the hour, 10, 20, 30, 40, and 50 minutes past the hour (seen in logs as H+00, H+10, etc.) to hear volmet's. Here is the U.S., they are run by the FAA. Question No. 3, "What is the Mossad?". Mossad Letafkidim Meouychadim (Central Collection Institute for Intelligence and Special Duties), - 'MOSSAD' for short, is the largest and most widely known of the Israeli intelligence services. The numbers stations who are believed to be operated by the Mossad, and possibly also by other associated Israeli intelligence services, are also known as '3-letter Phonetic' or 'Phonetic Alphabet' Stations. Ary Boender, who has followed these types of stations for years, passed on that in his book *By Way of Deception*, by former Mossad agent Victor Ostrovsky, that he describes their communications network as a "special non-stop station that is now computerized". These stations use a synthesized female voice for the broadcasts, which all start with a string of 3 letters (i.e. Charlie India Oscar) followed by blocks of 5 letter groups. When there are no messages suffix '2' is added to the call (CIO2). Sometimes other suffixes will pop up also. Now, on with the show . . .

UTE Logging's SSB/CW/RTTY/ARQ/etc. All Times in UTC

- 201: NDB DED DeLand FL at 0110, this beacon is local, and was off the air for 6-8 weeks. Just returned to air in early Dec. (WP)
- 205: XZ. NDB Wawa, Ont heard at 0754, 506m. (AH)
- 206: NDB QI. Yarmouth, NS at 0401, new catch, 400Hz. (JSM)
- 212: YRC. NDB St Honore, PQ at 0450, 483m. (AH)
- 219: AY. NDB Waycross, Ga at 0557, DSB, new. (PC)
- 223: YYW. NDB Armstrong, ONT at 0455, 1041m. (AH)
- 230: AND. NDB Anderson, SC at 0615. (PC)
- 232: GT. NDB Grand Turk Island, BWI at 0631, 1389m. (AH)
- 236: GNI, Grand Isle, La with voice wx. (JB) Unid weak voice comms at 0230. (KS) ("GNI", Grand Isle, La with voice wx -Ed.)
- 249: RKH, unid NDB at 0445, 1000 Hz., peaks N/S. (PC)
- 253: GRE. NDB Greenville, IL at 0727. (PC)
- 254: HLB. NDB Batesville, IN heard at 0609, DSB. (PC)
- 261: GD. NDB Goderich, ONT at 0323, 400 Hz. new freq (ex-286). (PC) 263: QY, NDB Sydney, NS at 0747, 954m. (AH)
- 270: NDB EZM. Eastman, GA at 0433. (RH)
- 272: NDB TYC. Campbellsville, KY heard at 0402. (RH)
- 275: BKK, NDB Bonifax, FL heard at 0851, DSB. (PC)

AR8000

All Mode Wide-Band World Band Radio Receiver



The Ultimate Handheld Receiver! "WELCOME TO THE WORLD OF THE AR8000". It incorporates the latest PLL technology and offers a multitude of features including true carrier re-insertion SSB (CW) demodulation with 50Hz frequency steps. 4 level alpha numeric LCD indicates the frequency, signal strength, band scope and more. Selectable squelch system, auto-mode, auto-band-plan, serial communication port are all standard. Internal ferrite antenna offers high performance reception below 2MHz..

When frequencies are entered, ALPHANUMERIC comments may be stored along with frequency, mode & attenuator status simplifying the job of recalling and identifying memory channels. There are a variety of scan/search commands to link banks, scan by mode, programmable delay scan, priority, auto memory store, step offset and a programmable power save circuit to increase the duration of operation from the NiCads. Keypad illumination extends to the side panel keys and may be switched in a number of ways. Illumination "Permanently On" for mobile operation is possible, a specially selected heavy duty regulator has been fitted to ensure the receiver will continue to operate reliably even with the illumination permanently On.

Main Features

- Frequency Coverage 500 kHz - 1900 MHz • All mode reception AM, NFM, WFM, USB, LSB & CW
- True carrier reinsertion and specific SSB filter with non-offset frequency readout • 1000 memory channels
- 20 search banks • Priority channel • Frequency pass • Rotary tuning dial • Step sizes programmable between 50 Hz & 999.995 kHz in 50 Hz increments • Scan & search speed up to 30 increments per second • Signal strength meter
- Band scope • Backlit LCD, Keypad & Side panel • Battery save facility • Separate controls for volume, squelch & dial
- Attenuator • Keypad beep on/off • Keypad lock • Top panel 3.5mm earphone socket • Monitor switch • Password protected banks • Programmable scan & search including free, delay, audio, level & mode • Select scan list • Computer control
- EEPROM memory backup (no battery required). • Two users modes: Beginner and Expert

Supplied with: NiCads, AC Charger, Hand strap, Belt Clip, Semi-flexible antenna, DC lead with cigar plug, Comprehensive operating manual with over 50 LCD illustrations.

Options: SC8000 Soft Case, AR8000INF interface, SAC8000 (Scout Adaptor Cable), Desk stand, DS8000 (Speech Inversion descrambling chip), MA500 antenna, ScanCat GOLD Software, RCSS8000 Software, RCSI-SoftControl 2.0, LA320 active loop antenna, QS200 Mobile bracket

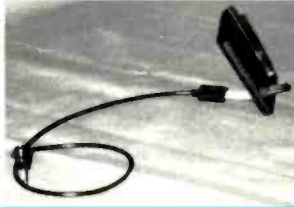

SAC8000 Adapter Cable

Once the SAC8000 is installed, the AR8000 can easily be connected to the OptoElectronics Scout™. Any frequency captured by the Scout™ instantly tunes the AR8000 receiver.

Purchase an AR8000 and buy a SAC8000 for just \$9.95...save \$20!



AR8000 Heavy Duty, tough leather carry case. A-300

Perfect for tough environments to protect your valuable investment.

The Hugger

"At your fingertips" convenience for handhelds and cellular phones. Quick, easy "no holes" mounting using your car air vents. Flexible gripper arms hug your radio yet allows quick, easy release.



WATSON WSC1

It can be changed from a handheld holster to a waist-belt holster or an adjustable sized body holster, to fit any handheld, portable telephone or even tools.

AR7000 • COMING SOON TO A DEALER NEAR YOU!



100kHz - 2GHz, DSP Receiver



PENDING FCC TYPE ACCEPTANCE: This device has not been approved by the F.C.C. this device in not, and may not be, offered for sale, or lease, or sold or leased.

SSE PSU101

Adjustable Desk Charger/ Power Supply
12VDC Version

This quality, custom-designed combination desk charger and regulated power supply unit is perfect for convenient 'Base Station' use of your handheld scanner at home or office!!

- Securely holds scanner in proper position
- Charges radio's internal NiCad w/out overcharging
- Powers radio from standard 117VAC house current

For: FIARMATE HP1000E/200E/HP2000

AOR AR1000XLT/AR1500/AR2000

YUPITERU MVT7000/MVT7100

UNIDEN BEARCAT BC50XL/BC55XLT/

BC70XLT/BC100XLT/

BC200XLT/BC205XLT

ALINCO DJX1

ICOM ICR1 Handheld

REALISTIC-TANDY-RADIO SHACK

PRO35/PRO38/PRO41



SSE PSU101TA

Desk Charger/Power Supply
9VDC Version

- 9 volt version for popular REALISTIC (RADIO SHACK) handheld scanners and others that require a 9 volt DC supply
- All the same quality & features of the PSU101 12 volt version above!

For: REALISTIC-TANDY-RADIO SHACK PRO34/PRO37/PRO43 and others.

WINDOWS™ Control for Scanners ScannerWEAR™ SoftControl 2.0 WINDOWS 95' COMPATIBLE

- Memory banks include 100 channels per bank with frequency, description and mode.
- Search ranges include frequency, step, mode and description. New database search by service codes.
- Data logging to the file includes date and time stamp, signal strength, tone and number of hits, location (requires PerCon Database)
- Spectra analysis uses search ranges or displays logged data
- NEW High Speed CTCSS & DCS controlled scanning with the RS-2005/6, RS-2035 and OptoScan with 456/535.
- CTCSS & DCS controlled scanning on R7000/7100 & AOR 3000/3000A AOR 8000 with optional RC-125 Tone Interface Box
- Scan multiple groups, banks, or search ranges in the same session.
- Birdie control file.
- Unlimited file size.
- Import PerCon Database and comma-delimited ASCII.
- NEW database scan by service code, create memory banks from service codes.
- NEW memory bank up and downloads for ICOM R7000/R71000 /R9000 and AOR 3000A/8000.
- NEW config window with support for com ports 1-8, IRQ calls on all ports, user modifiable dwell setting for all radios.
- NEW slave-master scanning with CIV protocol, scan on your receiver and all hits are transferred to the slave receiver for monitoring.
- NEW minimize window allows viewing of freq status while in any other WINDOWS or DOS application.

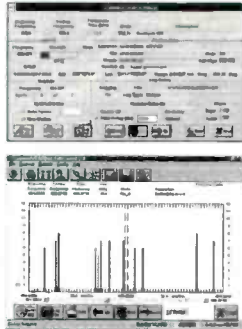

SCANCAT GOLD DOS OR WINDOWS VERSION!



SCANCAT presently supports:

- AOR3000/3000(A) & AOR2500, AOR-3030 HF receiver, AOR-AR8000 (Newest handheld) • Drake R-8 • MOST Icom Radios
- Kenwoods including TS-440, TS-450, TS850 & R5000
- Most Yaesu including FRG-8800 & FRG-9600 Yaesu, plus FRG-100, FT-840 and more! • The NRD-525 & 535 JRC.
- LOWE HF-150m • Watkins Johnson HF-1000
- Opto Electronics add-on boards for PRO series Radio Shack Radios

Software allows complete control of all functions supported by these radios through the standard manufacturer's interface.

SCANCAT allows you to:

1. Enter any two frequencies and scan between them with ANY increment, time delay or pause.
2. Scan a file of frequencies, search by description or wildcards.
3. Create databases of frequency files. Sort by any field, and save to disk and/or send to printer.
4. Create 30 personal "Preset:" frequency BANDS for SW, aircraft etc, including increment and mode. Multiple scanning Banks, multiple scanning diskfile banks, unlimited file sizes, dual radio simultaneous scanning, comma delimited conversion, d-base support, scanport gold, direct import of TRS. Macro control per record, command line control, automatic birdie lockout, top hits table.

Now Available! Scancat Gold for Windows...Same great features and support you've come to expect! Super windows graphic and commands for the smoothest possible operation. Now you decide...DOS or Windows 95 or 3.1

NEW from LOWE!!! The Professional Earphone LEP300

This earphone is designed to fit comfortably to one ear, the band behind the ear holding it securely in place. This design permits very low fatigue levels over long periods of use. The frequency response is optimized for communications use.



Impedance: 80ohms
Response: 400Hz to 9kHz
Sensitivity: 85dB
Power Rating: 250mW Max.

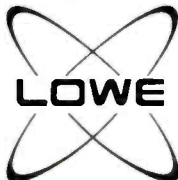

△△ MONITORING ACARS with the new LOWE "AIRMASTER" △△

The monitoring of air band communications is a hobby that has become more and more popular over the last 10 years. In common with the rest of the communications field, there are far reaching changes in process in this area to cater to the requirements of air traffic control in the next century. ACARS is a very specialized data mode, and only decoders that have been specially designed for it will function. Until now, the only decoders that will work have been fairly expensive devices, as they use dedicated hardware to handle the decoding.

The new Lowe Electronics Airmaster uses a small demodulator that plugs into the Com port on the back of a PC and takes its power from it. All the decoding of the data stream is handled by software running on the PC, which also enables some analysis of the messages to take place before they are displayed on the screen. Items such as the registration number of the aircraft, its flight number and the type of message are shown separately from the message text. Because the decoding requires a considerable amount of processing power, you will need at least a 386 PC to enable Airmaster to operate.



CIRCLE 131 ON READER SERVICE CARD

1300 DISCONE

If you've been looking for a superior wide band omnidirectional antenna covering 25-1300MHz, the 1300 is the ultimate wideband omni-directional antenna for hours for listening pleasure.

Receiving: 25-1300MHz
Transmit: 50, 144, 222, 430, 900, 1200MHz
Connector: Low Loss "N" type
Max. Pwr.: 200 watts
VSWR: 1.5:1 on bands listed above
Mast Dia.: .98" -2" **Length:** 5'6" **Weight:** 2.2lbs



NEVADA

Electronic Distributors
325 Mill St. • Vienna, VA. 22180
Ph: 703.938.8105
FAX: 703.938.4525
www.elecdist.com



**For more information see
your favorite dealer.**

Abbreviations Used for Intercepts

AM	Amplitude Modulation mode
ann	Announcement
BC	Broadcast
CW	Morse Code mode
EE	English language
FF	French language
GG	German language
ID	Identification
LSB	Lower Side Band mode
OM	Male Operator
pp	Phone Patch
RR	Russian language
SS	Spanish language
tfc	Traffic
USB	Upper Side Band mode
w/	With
wkg	Working
wx	Weather
YL	Female Operator
4FG	4-Figure coded groups (i.e. 2951)
5FG	5-Figure coded groups (i.e. 29517)
5LG	5-Letter coded groups (i.e. IGRXJ)
//	Parallel

278: NDB GPQ, Carrollton, GA at 0455. ex-239. (JB) NDB GPQ. GPQ is listed as Carrollton, GA but on another freq. assume they moved? (KS) (Yes. ex-239 -Ed.)
 284: AUV, NDB Ardmore, OK at 0940. (PC)
 289: YLQ, NDB La Tuque, PQ heard at 0524, 412m. (AH)
 290: NDB YYH, Spence Bay, NWT heard at 0450. (RH)
 304: F, NDB Moncton, NB heard at 0526, 499m. (AH)
 317: NDB R. Canadian Forces Base Trenton, Ont. at 0352. (RH)
 322: H. NDB Seal Island, NS heard at 1705, 298m. (AH)
 323: HHW, NDB Hugo, OK at 1034, DSB, new. (PC)
 330: NDB CZM, Cozumel, Mexico heard at 0542. (RH)
 338: NDB MS, New Orleans LA (int'l) at 0349. (WP)
 339: NDB A, Jose Marti (int'l) Havana Cuba at 0345. (WP)
 343: 6R, NDB Bromont, PQ heard at 0550, 267m. (AH)
 344: NDB CL, Cleveland, OH at 0433. (JB)
 346: LI, NDB Boston, MA at 2324. (PC)
 350: NDB DNS, Denison, IA at 0609. (RH)
 353: NDB, MG, Montgomery, NY heard at 0937. (RH)
 360: NDB KIN, Kingston Jamaica (Norman Manley int'l) at 0357, had a t5 note. Listed in Stryker's as 1KW but at 10 feet of elevation. Kingston is ringed w/high mountains, & on the south side of the island. This one is a "tuffy" even in Florida. I've copied it only twice in several years. (WP)
 364: 2B, NDB Springdale, NFLD at 0827, 878m. (AH)



FAX chart received by Dave Wright (TX) from NMC, USCG Point Reyes, CA.

377: NDB CWI, Clinton, IA at 0222. (RH)
 382: 2F, NDB Bathurst, NB at 0718. (PC)
 385: NDB NA, Natasquan PQ (long dash after call) at 0335. (WP)
 387: PV, NDB Turks & Caicos, BWI at 0949, 1366m. (AH)
 390: NDB JT, Stephenville NFLD heard at 0335. (WP)
 394: NDB OR, Chicago, IL (O'Hare) heard at 0158. (RH)
 399: NDB G, Charlottetown PEI (long dash after call) at 0345. (WP)
 400: NDB OHY, Cordele, GA at 0338. (RH)
 402: SJE, NDB San Jose de Guaviare, Columbia heard at 0750. 1200 Hz DSB, dit after ID. (PC)
 403: R, NDB Toronto, Ont heard at 0648, 453m. (AH)
 407: NDB H, Montreal, PQ at 0646, 400Hz, 2nd time in 10 years. (JSM)
 410: NDB JU, West Jefferson NC heard at 0355. (WP)
 414: NDB BC, Baie Comeau, PQ at 0441. (JB)
 415: NDB Lebanon, MO at 0752. DSB? (PC)
 416: NDB BKL, Cleveland, OH at 0655. (JSM) (Burke Lake Front Apt there -Ed.)
 417: NDB IY, Charles City, IA at 0645. (RH)
 418: CW, Lake Charles, LA at 0506, LSB only heard (JSM)
 420: NDB GAS, Gallipolis, OH at 0030, 350 m. (14 miles/watt). (KS)
 423: NDB DXE, Dexter, MO at 2355, 390 m. (15.6 miles/watt). (KS)
 426: NDB IZS, Montezuma, GA heard at 0545. (JSM)
 428: COG, NDB Orange, Va at 425m. (AH)
 429: NDB IKY, Springfield, KY at 2300, 260 m. (10.4 miles/watt). (KS)
 430: NDB VA, Varadero, Cuba at 0342. (RH)
 432: NDB MHP, Metter, GA at 0542. (JSM)
 434: WLO, Mobile LA, w/tfc list in fast CW at 0410. (WP)
 450: NDB PPA, Dominican Republic heard at 0541. (JSM)
 478: WNU, Slidell LA, w/marine wx in fast CW at 0412. (WP)
 521: TVX, Greencastle, IN at 0556. hrd most nights. (JSM)
 530: F9, NDB Chatham, NB heard at 0723, 476m. (AH)
 1620: Shenandoah TIS, Va at 0005, weak, w/loop, sounds like both stations there now running the same tape. (AH)
 2182: VCBT: Canadian Fisheries & Oceans patrol vsl Cape Roger at 0438 clg unid vsl. (Ed.) VCS, Halifax CG Radio, NS, at 0433 w/secure bdest. At 0503, VAU, Yarmouth CG Radio, NS w/same. At 0634, VCM, St. Anthony CG Radio, NF w/ same. At 0708, VOJ, Stephenville CG Radio, NF, w/same. (JSM) VCG, Riviere-au-Renard Canadian CG Radio at 0441 w/secure wx bdest. (JP) All in USB. 2686: N28WL: as NCS at 0606 in USB, app Canadian Forces link-11 coordination net, w/5NEI, X1L2, N35P, 2QM9, 1DA8, O2P8, & MAPLE LEAF. (Ed.)
 2749: VAU, CCG Yarmouth, NS at 0541 w/MIB. At 0604, VCS: CCG Halifax, NS w/MIB. At 0634, VCN: CCG Cap-Aux-Meules, w/MIB. At 0520, VCO: CCG Sydney w/MIB in EE. Switched to FF at 0524. All in USB. (DW)
 2840.7: German Coast Guard, Cuxhaven, D wkg CG/gov't ships in ARQ as follows: DLGZ; mv BG21 Bredstedt, at 0913 re posn report: DLVB: mv Schleswig-Holstein, at 0904 for same: DBIG: mv BG23 Sellin, at 0916 for same: DGOQ: mv charhorn, at 1615 for same: DRCZ: German navy vessel Wismar, at 1940 for same. At 0905, Coast Guard Cuxhaven, w/msg to all CG vessels (AB)
 2935: Japanese Ground-to-Air tfc in USB at 1400, sounded like one of stations ID'ed as "Tokyo". (DS)



Photo included in Royal Navy 771 Naval Air Squadron booklet sent to Ed Rausch (NJ) for his QSL of Plymouth Rescue on 5680.0 kHz. 771 NAS is based at RNAS Culdrose, sometimes heard on 5696.0 (USCG freq) ID'ing as Culdrose Op's. Photo shows 771 Sqd Sea King working with Royal National Lifeboat Institute (RNLI) SAR boat.

3023: Coast Guard "Oscar Charlie" at 2212 in USB w/Kinloss Rescue w/posn report. (AB) (Note that UK CG helo duties are contracted out to Bristow Helicopters and they use a regular British civil aero reg#, G-BDOC in this case -Ed.)
3116: Khabarovsk Volmet in USB at 1817, YL/RR strong. (DS)
3206.5: Portuguese police, POR at 2336 in ARQ, msg to P.Cont.(AB)
3455: Tokyo Radio, selcal'ed SAM 27000 at 1310 in USB, adv ATC says unable Flt Lvl 330 due to t/c, also adv 27000 of ATC clearances to Honolulu. (DS)
3832.7: RFFP, MOD Paris, Fat 0047 in ARQ-M2 w/200/400 msgs to RFFVAY w/5LG's (AB) Same at 0320 w/a; idle b; idle.(SS)
4027: Russian Intelligence, poss Cuba, heard at 0315, in EE w/"543" call up, into 5FG 2x, xInt. (AWH)
4320: IAR, Rome Radio, Italy at 0429 w/CW V-marker. (WP)

4350: TBB5: Turkish Navy Ankara, TUR at 2331 in CW clg TBJ (collective callsign for all Turkish warships). (AB)
4452: Unid at 0615 in ROU-FEC 164.5/400 w/encrypted t/c. (SS)
4510.7: NE0021: Nebraska CAP unit 21 at 0419 in PACKET clg MO0920: Missouri CAP unit 920 using repeated NCR004: North Central Region 004 No joy. At 0422, NE0021 clg IA0043: Iowa Cap unit 0043. Again, no joy. North-Central Region CAP Packet Net formerly on 4506. (DW)
4558: "C", Russian Navy, Moscow, RUS at 2235 in CW w/channel marker (AB)
4880: Mossad, ISR heard at 2230 in USB w/ULX2 broadcast (AB) Same heard at 1730, YL/EE w/"ULX2" in phonetics till 1733, then down. (DS)
5135.3: Probable babler here. 1545 to 1555 in AM, strong carrier w/some telco tones, pretty clean overall though. No traffic noted before plug pulled. Might be the same tx nor-

mally heard on 5341, similar audio. (AWH)
5238: "Counting Station" (presumed Vint Hills) w/3/2FGs at 0200 callup for 519. Other carriers w/ same type background noise noted on 4891 (no t/c, period) and 5407 (went into unknown format data). (AWH) YL/SS w/counting grps 0200 to 0226, same station on the next night to 0230. (GS)

5245: MRC01, RAF Cadets Wellingborough (C-net Control), G at 1215 w/MRH19 RAF Cadets unid location; MRH08, RAF Cadets Lymington, G at 1140 w/MRA01 (A-net Control); MRC17, RAF Cadets, G at 1124 w/MRC01 Net Control Wellingborough; MRC28, RAF Cadets, Wellingborough, G at 1144 w/MRC01 Net Control Wellingborough; MRL50, RAF Cadets, Finchley, G at 1156 w/MRC17; MRO17M2, RAF Cadets mobile unit, G at 1230 w/MRC28. All in USB. (AB)
5294.4: Probable babler in LSB 1550 to 1710, but no babble t/c per se. Telco noise at t/in, lots of hum. At 1605 suddenly went into SS w/5FGs without callup, hunting around found it // the normal 6855 Cuban station! Seemed to be relaying off-air, but doubt associated w/same ops group. Continued relaying until "final" at 1618, then just noise/hum until pulled plug. (AWH)

5320: NOQ, USCG Group Mobile, AL, at 0136 in USB w/kg S5U re att to get info on two vsls. (Ed.)

5340: LOLO, Swedish Rhapsody, heard at 2000 in CW w/5FG's after several mins of 'LOLO' id (AB)

5344: BMBX, British Army Combined Cadet Force, G at 1220 in ARQ w/CCF Mailbox w/21B, 43A, 60C and 53C (AB)

5405: MJJ2: Tokyo Meteo at 0828 w/FAX 120/576 w/wx chart. (DW)

5411: Russian Man (a real one) at 0500 w/OM, in AM, RR callup "498 498 498 1" repeated, at 0505 "404 48" into 5FGs 11x. Gone by 0512 recheck. (AWH)

5493: Air Afrique 741 at 0159 w/kg Kinshasa ARP F370 departed Brazzaville 0135 ETA Abidjan 0322. Passed MIKMA at 0154. A300 reg. TU-TAH; CCL 301 at 0251 w/kg N'djamena w/ARP departed Orly, dest. Kisan-gani @FL 330 next call DIR; Gbadolite Radio at 0235 w/kg Kinshasa receiving t/c rpt re: LH574: Mozambique 707 at 0109 w/kg Brazzaville w/ARP RULDO 0105 F290 BOSSA 0117 req FL 370. Cleared to F370 & in QSY w/AFM 006. All in USB mode. (TO)

5517: Air Afrique 9926 at 2355 w/kg Cairo w/ARP ME 2353 FL 280 BOPID 0027 KTM; Cairo Radio at 0006 w/kg Khartoum w/t/c rpts re: FIN1983, an MD80 en route Luxor-Mombasa, N998JB G.3 Luxor-FVHA; Gulf Air 713 at 0003 clg Sanaa here no joy. Then, Sanaa finally responds after a minute: Air France 445 at 0030 w/kg Khartoum w/ARP ALVOR 29 F310 ORNAT 0107; Entebbe Radio at 2351 w/kg Cairo w/t/c rpt re: SAA 222: Lufthansa 573 at 0125 w/kg Tripoli F350 est SEB 0205 GRT 0232; Mauritius 051 at 0012 w/kg Mogadishu w/ARP, o/h MOG 11 FL 370; Sanaa Radio at 0012 w/kg Addis w/t/c rpt re: Iran Air 515 B707 Dubai-Entebbe FL 350;

Seychelles Radio at 2358 wkg Mauritius w/tfc rpt re: AF465. All in USB mode. (TO)

5541: CONNIE 357 at 1934 in USB wkg Stockholm Radio, pp Connie Ops re ETA Dallas 0289Z, re wx & hotel reservation for 7 person crew. (KW)

5628: Hong Kong 089 w/posn report to Tokyo Radio in USB at 1841, a/c reported waypoint "NIPPI" (4942.6N/159.20E) at 1836, FL 310, est "NUBDA" (4223.3N/14728.8E) 2054, "NODAN" (4025.0N/14500.0E) next. (DS)

5634: Mauritius 755 at 0040 in USB wkg Mauritius w/ARP MONTO 0039 FL 330 MURUS 0129 req FL 390: Mauritius Radio at 0149 wkg Antananarivo R. w/tfc rpt re: MH203. (TO)

5658: Singapore 337 w/unanswered calls to Karachi Radio in USB at 1616. (DS)

5661: Saudia 341 (EM-HL) heard at 0615 in USB working Malta enrt Jeddah-Algiers est posn ARLOS 0630 NOFSA 0701 o/h MLG 0731. (TO)

5670: Speedbird 12 in USB heard at 1740 w/Madras, reporting "SAPLO" (10-36N/94-25E) at FL310, selcal "BD-FM" G-BNLR 747-400. (JSM)

5680: Hay River Aeradio, NWT in USB at 1542 testing. (JSM)

5696: HERCULES 04, USCG HC-130H7 #1504 (id'd earlier) at 1107 wkg SWORD-FISH 20; prob USCG HH-60J #6020. (DW) RESCUE 6009, USCG HH-60J helo at 0700 wkg NMN, CAMSLANT Chesapeake for radio guard re is airborne enrt SAR in Chesapeake Bay for 1 PIW (Person In Water). STALKER 31, USCG HU-25 2131 at 0400 wkg NMN re ID of SHARK 910 (USCGC Thetis, WMEC-910), NMN adv is unk to them. (Ed.)

CG 1603 at 0215 enrt from Sacramento, CA to Elizabeth City wkg "Sac Air" and "E City Air" w/CAMSPAC helping to relay at times. (WT) All in USB mode.

5875: WAR46 at 1907 in USB clg NIGHT-WATCH, no reply. (AWH)

6200: NRPJ, USCGC Laurel (WLB-291) at 0444 in USB clg CommSta New Orleans, NMG, no joy. (Ed.)

6237.5: DNVN, vsl ATHENA MARIS at 0350 in ARQ w/tlx's to Eastmed. (WT)

6460: UFZ, Vladivostok R. at 0620 in RTTY 50/170 w/tlg's in RR. End w/"73 DE UFZ SK". (WT)

6483: PBB, Dutch Navy Den Helder, Nld at 2245 in RTTY 75/850 CARB message. (SS)

6516: NOP, USCG AirSta Brooklyn, NY, "Brooklyn Air", at 1547 wkg unid a/c 7-tango w/posn in USB. (Ed.)

6535: Lufthansa 503 (LM-DS) at 0528 in USB wkg Dakar w/ARP MOGNI FL 330 ONOBI-CVS. (TO)

6556: BRUNEI 396 wkg Jakarta Radio in USB at 1517, reported way-point "KIBON" (0150.0S/11000.0E) at 1517, est "EBONY" (0054.5S/11042.2E) at 1526, "OMEGA" (0023.0S/11107.2E) next. Singapore, Perth, & Ujung Pandang also hrd this freq approx same time (DS)

6589: Unid Cuban net here again today, 1408 w/ USTACA in AM. (?— wonder if this is really OSAKA or something) clg ROMANA. At 1413 ROMANA clg W153, answered. At 1448 OM w/long counts, including self-amused falsetto. OSAKA or whatever, sounded like an a/c today, didn't previously. W153 also. Carrier gone at 1520 recheck. I wonder if this might be a VHF or UHF MIL air freq picked up & relayed? (AWH)

6637: AMTRAN 8031 at 2128 wkg Houston Radio re selcal ck "CK-FM", also tried 10075, better on lower freq. (KW) Amerijet 741 at 0828 wkg Miami arr MEX 0801/05 ETD 45 mins. (TO) Both in USB.

6655: CATHAY 829 wkg Tokyo Radio in USB at 1501, a/c was est "NOGAL" (4611.9N/15300.5E) at 1552 & "NUBDA" (4223.3N/14728.8E). (DS)

6666: Poss Cuban military voice net at 1800 on in AM, ex-6589/4787/etc. now here, at 1810, H591 calling USACA or similar. Often uses nonsensical but pronounceable call-words. Multiple stations have been noted on net previously, but sounds like one tx relaying multiples from another frequency or line, telephone noises also, carrier stays on continuously. Gone at 1844 recheck, but back at 1852 up on 6667, clg USACA again. Back later on 8068. (AWH)

6676: Bangkok Volmet in USB at 2042, OM, strong. "Bangkok Radio out" at 2045. (DS)

6693: Tyumen VOLMET 0522 USB w/wx info. (DW)

6751: Probable Japanese military air/ground comms in USB between 0730/0832, heavily accented EE, ground stations ID'd as something like "JJF" (OM) & "JJV" or "JJB" (YL). they worked at least 2 a/c with Alpha-numeric calls, one of which was XOC passed in phonetics, the usual routine was a call-up by the a/c, followed by signal ck's, authentication challenge/response & preparation to send data. RTTY followed, then ending w/voice sign-off. There were occasional data bursts, maybe secure voice, between call-ups, all op's in heavily accented EE, a bit of Japanese, & NATO phonetics. (DS)

6815.6: SHARK 716: USCGC Dallas (WHEC-716) 0341 USB wkg SHARK 622, USCGC Courageous (WMEC-622) re posn of 'target' & if OMAHA is still up. At 0346 S3Q wkg 17G req they go 'green'. (Ed.)

6826: Cuban? Numbers station at 0300 in AM w/SS "Atencion 04400", into 5FGs (as 3060 KHz), weak audio. (AWH)

7305: JMH, Tokyo Meteo at 0530 w/120/576 FAX w/Pacific Surface Analysis Polar Projection. (WT)

7337: Lincolnshire Poacher broadcast in USB at 2200, starts up w/12 repeats of the LP jingle, followed by YL/EE w/10 repeats of '55235', weak //9251//12603. (DS)

7433.5: HLL5, Seoul Meteo, KOR heard at 0753 w/120/576 FAX w/quality maps of E. Asia. (WT)

7535: NGHY: USS Peterson (DD-969) at 1357 wkg SESEF w/req for tests of 3 HF xmitters. NICB: USCGC Forward (WMEC-911) at 1619 w/req for TACAN testing, voice coordination went to 274.8 UHF. Both in USB. (Ed.)

7540: Mossad broadcast in USB at 1531, YL w/"JSR" in phonetics till 1534, then "message message group 69, group 69, text, text & into 5LG's. (DS)

8057: SAM 201, USAF C-20B tail 86-0201 at 2050 in USB wkg Andy w/pp. (Ed.)

8176: "Guam Radio" at 0805 in USB w/MIB, signed off w/Guam Radio out". (DW)

8240: SVBT: 35,368 DWT Greek-flagged bulk carrier M/V Doric Trident at 2202, clg Portishead Radio for R/T t/c. (Ed.) USCGC Juniper (WLB-201) at 0437 wkg COMMSTA New Orleans. (JP) Both in USB.

8297: ADNF: USAV Perryville (LCU-2034) at 0526 wkg AAC2, U.S. Army Transportation Corps., Ft Eustis, VA, re AAC2 did not receive ADNF's last posn report. (DW) AADV, USAV Bristow Station (LCU-2006) at 0125 wkg AAC2. (JP) Both in USB.

8335.5: DRAI, German Navy frigate FGS Schleswig-Holstein (F-216) at 0718 in USB, wkg DHJ59, Wilhelmshaven Naval w/QLS of RTTY t/c. (Ed.)

8353: WXBR, Chevron, Mississippi in CW hrd at 0424 wkg VAI w/AMVER/PR posn 46N/150W stgr 199 deg hrd at 15.5kts. (JSM)

8370.1: UEYP clg UAT, Moscow Radio, for 4 minutes in CW at 0330. (WP) (Russian vsl TKH Tonya Bondarchuk -Ed.)

8382.5: BROO, Chinese vsl Jin Ji Ling at 2058 in ARQ, posn 2115N/11841W & ETA Balboa. Login 20151 BROO. (WT)

8384: T/H Global Force at 0700 in ARQ w/DISP-1 msg to Odessa, signed KM Inozentsev. (DW)

8400: UTMQ, RS Oskar Luts at 0811 in RTTY 50/170 w/TG's. (DW)

8417: ZLA, Globe Wireless, New Zealand at 0615 in FEC w/MEBa nx. (WT)

8452: VIT, Townsville R. Australia at 0744 in CW w/mkr w/"QSX 500/8369 KHZ". (WT)

8478.5: FUF, French Navy, Fort de France at 0914 in RTTY 75/866 w/test tape. (DW)

8484.5: HZG, Damman Radio, Saudi Arabia at 0432 w/CW QSX marker. (WP)

8495: "S", Russian Navy, Arkhangelsk, RUS at 1438 w/CW Channel marker (AB)

8514: XSQ, Guangzhou Radio, PRC in CW at 1510 w/"CQ DE XSQ PSE UP 341 CL K". (DS) (adv a vsl to come up 8341.0 -Ed.)

8607: USU, Mariupol Radio, UKR heard at 2202 in RTTY 50/170 w/R/YRY to URMA, TKH Skvortsov-Stepanov, & into t/c to master. (Ed.)

8650: SBP43, Szczecin Radio, POL at 1325 in ARQ w/various vsls. (AB)

8698: FJP8, Noumea, New Caledonia at 0534 in CW w/CQ call. (DW)

8703: UCE, Arkhangelsk Radio, Rus at 1125 in RTTY 50/158 w/TGs for various Russian vsls. All were "Happy New Year" TG's. (DW)

8706: JOS, Nagasaki Radio, Japan at 0850 w/CW marker, "QSX 8 MHZ". (WT)

8812: OM/CC in USB heard at 1441 w/(as near as I could get the sounds) "cho li shieh beijing ontai (2x), shen dai wu shieh (2x), chon tai (3x), abruptly down in mid-sentence at 1444. (DS)

8861: Iberia 6843 (HL-BD) at 0550 wkg Recife, ARP RAKUD FL310: Malaysia 202 at 0552 wkg Johannesburg ARP 5E 0551 FL 370 est Equator 0621. Both in USB.(TO)

8867: Auckland at 0611 in USB wkg 4107, who was airborne from Auckland. (DW)

8879: Singapore 406 (BP-JS) at 0058 wkg Beira w/ARP SUNIR, at 0146. FL390, est APLAR 0227, VMA 0237 ETA JNB 0315. Indian 923 (JP-LM) A320 w/reg VT-EPT at 1251 wkg Bombay w/ARP ATARA?. FL370 ETA AUH given. Both in USB. (TO)

8888: Springbok 238. 747 reg. ZS-SAJ at 2112 in USB wkg Luanda ACC w/ARP, FL310, est BUGRO 2111, VUE 2157, ANUBI 2245, ETA LHR 0700. (TO)

8891: Korean Air 022 at 2208 in USB wkg Churchill Radio w/ARP YMM 2201, FL370, ETA JFK 0125. (TO)

8894: Air Afrique 134 (CG-AS) at 0315 in USB wkg Alger w/ARP AMTES. FL330, Insalah 46. (TO)

8900: Babbler, heard at 1553 in USB, SS/OM w/long counts, very poor audio, weak. A rare one. (AWH)

8903: Cotam 2685 at 2006 in USB clg N'djamena no joy. Heard later from a t/c rpt from Brazzaville that this was F-RAGO enrt N'djamena-Bangui. (TO)

8992: MAGIC 55, NATO E-3C AWACS, at 0354 in USB wkg Ascension GHFS w/morale pp's. (Ed.)

9362: PIAB Bonn at 1342 in FEC-A 96/400 w/GG nx. (Ed.)

10033: Giant 704 at 1757 in USB wkg Miami Radio re dep GDL 1730. ETA Miami 2040Z. Selcal Ck "DK-AJ". QSY to 21964 for another. Selcal Ck. (KW)

10075: North American 24 at 2111 in USB wkg Houston Radio re ETA JFK 0115 & selcal ck "EG-AJ". (KW)

10117: BAF4, Beijing Meteo at 0843 in 120/576 FAX, funny looking wx maps but label definitely Chinese. (WT)

10162.5: YIL71, INA Baghdad, IRQ at 1306 in RTTY 50bd EE nx. (AB)

10726.5: P6Z, MFA Paris at 1440 in FEC-A 192/379 w/t/c for D2Z (French Embassy, Budapest). (DW)

10749.5: Prob 'C37A'. MOSSAD, Tel Aviv heard at 1436 in ARQ-E 288/270, w/encrypted t/c. (DW)

10780: NRDW, USS De Wert (FFG-45) and NIKL, USCGC Tampa (WMEC-902) wkg Cape Radio at 0123 in USB re support of launch of STS-81. (JP)

11080: SANA, DAMASCUS, SYR at 1641 RTTY 50/400 w/ATU-70 Arabic text, FF & EE.(SS)

11387: Bangkok Volmet in USB at 0542, YL/EE, weak w/"Bangkok Radio out" at 0544. (DS)

11545: Lincolnshire Poacher, YL/EE heard at 1400 to 1405 in USB very faint but still audible. (GS)

12225.3: CWB, Bulgarian Embassy, London 1320 in unid 363.78/375 hi speed system, ACF=25/105, 75/469 RTTY op chatter about problems w/hi speed system & back to hi

speed system w/RYS/cwb cwb cwb/RYS then off. (SS)

12482: 3FX13, M/T Hero at 1820 in ARQ w/Amver/PR, 1316N 07212W. (WT)

12603: Lincolnshire Poacher broadcast start-up in USB at 2208, 12 repeats of the LP tune alternate w/YL/EE w/10 repeats of "55235", weak, //7337//9251. (DS)

12623: KBQ, Sea Link Hawaii at 1818 in ARQ QSLing for ships t/c. (WT)

12647: LPD, General Pacheco Radio, Arg w/CW ID & sitor at 0225. (WP)

13309: Hong Kong wkg MACRO 882 in USB at 0626. (DS)

13348: Connie 807 at 1400 in USB wkg Cedar Rapids LDOC w/pp to Ypsilanti Ops rptng out GUA 1305 off 1322 ETA MIA 1529. (TO)

13393: WFO? Russian Intelligence (ex-SOUD), prob Cuba heard at 2010 in RTTY 75/500, t/c for HZW, msg header "11177 00117 40338 26140 00614" into 50 5FGs, qru sk, then gone. (AWH)

13457: KCP63, FAA Longmont (Denver)at 1754 in USB as NCS, wkg KMR96, FAA Fremont. Ca w/net check in, app cud not hear 96 on the primary freq. (Ed.)

13927: NDQV, USS Spruance (DD-963)at 2235 in USB w/odd log of the month, wkg AFAIEN, USAF MARS, w/pp t/c, ID'ing as November Delta Quebec Victor, the ships inter'l callsign. (Ed.)

14469: Cherry Ripe broadcast w/12 repeats of CR tune, alternates w/YL repeating "61671" 10x in USB at 1103. (DS)

14510.7: CLP65, EMACUBA Managua, NICARAGUA at 2130 to 2151, RTTY 75/500, mostly online ZZZZZZ crypto stuff, lot of dead air, some clear SS chit chat, no ID seen. Havana side not heard, including usual 13395 freq. (AWH)

15388: New Star Radio Station (new freq).

YL/CC w/extended sign-on blurb heard in AM at 0704, started passing 4FG's, each 2x at 0707, non// broadcast was concurrent on 13750, hrd the "shinshing kwangbo dientai" ident on the 15388 start-up. (DS)

16078.7: CLP1, MFA, Havana, Cuba at 1801 in RTTY 50/460 w/minrex reports to unid embassy. (Ed.)

16694: HBFT, M/V Silvretta at 2310 in ARQ w/Amver/PR. 2049N 12632W. Login 51102 HBFT. (WT)

17308: BVA, Taipei Radio w/YL voice ann in USB at 0659. (DS)

17904: Japan Air 794 wkg Honolulu Radio re clearance to Nagoya in USB at 0434. (DS)

18221.2: CNM76X9, MAP, Rabat, MRC at 1655 in RTTY 50/425 w/FF nx items. (Ed.)

18415: 8BY, French intelligence at 1553 w/CW v-marker. //14930. (AWH)

18966.7: RFHJ, FN Papeete at 1900 in ARQ-E3 96/400 Idle. (WT)

20048 "C", Russian Navy Moscow at 1009 w/CW Channel marker. (AB)

20474: Cherry Ripe broadcast in USB heard at 2331, YL/EE w/5FG's, ea 2x, strong & //17499. (DS)

Thanks to this month's contributors: (AH) Al Hemmalin (RI); (AWH) Albert W. Hussein (FL); (AB) Ary Boender (The Netherlands); (DS) Dave Sabo (South Korea); (DW) David C Wright (TX); (GS) Gary Seven (NY); (JB) John Bryson (PA); (JP) Jim Pogue (TN); (JSM) Steve McDonald (BC, CAN) (KW) Ken Windyka (NY); (KS) Kevin Scott (GA); (PC) Perry Crabill (VA); (RH) Russ Hill (MI); (SS) Stan Scalsky (MD); (TO) Tony Orr (VA); (WT) Wade Taylor (CA); (WP) Walt Petersen (FL); (Ed.)ye editor in OH.



If you're planning a move in the near future, don't risk missing an issue of Popular Communications. Please give us 6-8 weeks notice if you're planning on changing your address. Just write your new address and mail it, WITH YOUR SUBSCRIPTION MAILING LABEL, to:

POPULAR COMMUNICATIONS
76 North Broadway, Hicksville, NY 11801



Message Tracker™

Paging System Monitor

- POCSAG - 512, 1200, & 2400 baud
- GOLAY - 600 baud
- Auto Baud Rate Detection
- Allows option to monitor all messages on channel
- Runs in DOS and Windows (3.1 or higher)
- Minimum System Requirements
 - 33 MHz 386 for Windows
 - 20 MHz for DOS
 - RS-232 16550 Serial Port
- Run Up to 4 Message Tracker units on single computer
 - Each unit purchased separately

K & L Technology
P.O. Box 460838
Garland, Tx 75046-0838
Phone/Fax: 972-414-7198
E-mail: KLTsupport@aol.com

HF-VHF Receiver Multicouplers

***** 100 KHz to 1 GHz range*****

Are you using several HF radios or VHF/UHF scanners at your monitoring site??
Diversity Reception antenna systems??
....consider including a multicoupler.

Specially designed for **demanding monitoring** applications and for the dedicated hobbyist with multiple monitoring radios. Our **2 and 4 port couplers** are 50 ohms units with better than **22 dB of port-to-port isolation**. BNC connectors standard, type-N and SMA also available. Other port configurations on special order.

Please contact us for a Data Sheet and pricing \$70 to \$90 range - VISA/MC accepted

Stridsberg Engineering, Inc.
PO Box 5040, Shreveport, LA 71135-5040
(318) 861-0660 FAX: (318) 861-7068

The Ham Column

BY KIRK KLEINSCHMIDT, NT0Z

GETTING STARTED AS A RADIO AMATEUR

The Wait is Almost Over!

Even in today's age of technology, with 800 numbers, fast computers and a user-friendly FCC, every new ham faces an age-old frustration. You've studied long and hard and you've just passed your Novice or Technician test. The first obstacle on the road to radio enjoyment is behind you and you feel like a million bucks. You'll soon be a ham operator, but until your call sign is actually *issued* by the FCC, you're playing the waiting game.

Until that glorious moment, you're technically not a ham: but there are things you can do to lessen the frustration and ensure your first QSO will be all that you've imagined. The time between passing your test and the arrival of your license can be one of the most profitable times of your amateur radio career. Use the time wisely. Prepare your radio shack—and yourself!

Keep on Learning

You might not want to hear this right now, but while you're still in "study mode," keep right on studying! All the work you put in preparing for your Novice or Tech test is only the beginning of a lifelong process of radio education. Get the study materials for your next license class and get to work! You'll go from SWL to Extra Class in a hurry if you get into the upgrade habit early.

"... until your call sign is actually issued by the FCC, you're playing the waiting game."

Make friends with the hams in your area. Tell them who you are and describe your situation. Visit as many local hams as you can. Chances are they'll be happy to have you over and will enjoy the opportunity to welcome you to the local radio scene. One great way to meet new hams is to join a local radio club. If you'd like information on the clubs in your area, drop me a line at the address given at the end of the column. I'll be happy to send you a list. You'll probably find that talk-

ing with other operators provides some "real-life" information to augment what you've learned from the study guides. Besides, it's never too early to make new radio friends!

Prepare Your Shack

Ham shacks are "sacred ground." Your shack doesn't simply house your ragtag collection of amateur radio stuff—it's a shrine to the radio gods! It's where ham radio *happens*, so, right from the start, you should make it as comfortable and as functional as possible. And don't be afraid to personalize your radio space, either. Make it just the way you want it—within the bounds of good taste (very flexible) or parental/spousal considerations (not always flexible!).

Before you buy a rig, there are a couple of things you should do: (1) Prepare your operating position and (2) Put up a good antenna.

Getting your shack ready is important: Timely assessment of power sources, available space and possible antenna locations can make radio more enjoyable later. Although it's difficult to offer specific advice, a few observations are in order. The shack and antenna location should be considered a single problem. It does little good to erect an antenna in a place where it's difficult or nearly impossible to run the feed line to your shack. On the other hand, if your antenna's too close to your shack, you may have RF feedback problems. This is called having a "hot" shack—and you should avoid it!

Ideally, your shack should be at ground level or even in the basement—if the humidity can be adequately controlled—because of easy access to power panels and a good earth ground. If you must set up your shack on the second or third floor, don't despair. A simple counterpoise (detailed in any ARRL Handbook) will get you on the air. Your shack should proba-

The Fastest Way to Get Your New Ticket

Because ham radio licensing exams are administered and processed through VECs, and not handled exclusively by the FCC, there's a fast way for you to find your new call sign. It's a lot like an amateur radio version of the "Rapid Refund." (VECs are Volunteer Examiner Coordinators, and there are 16 of these organizations around the country that work with the FCC to process amateur radio license exams.)

Using the ARRL VEC as an example, it works like this: You take your exam, and when you pass, the examiners send your test results to the ARRL VEC via Priority Mail or an "overnight delivery service." Upon arrival, the ARRL VEC looks over each application to make sure everything's filled out correctly. At the close of business each day, all processed applications are sent to the FCC via computer, where, on a good day, call signs for these submitted and previously processed applications can be issued before midnight the *same day!*

Sometime in the wee hours of the morning, the FCC computer releases information on all of the newly processed licenses to the 16 VECs and to several sites on the Internet.

As soon as call signs are "issued" by the FCC, you're a bona fide ham, and if you know your call sign, you can get on the air right away, before your ticket arrives in the mail! To do this, you'd call the ARRL VEC a week or so after passing your test (860-594-0300). Workers at the VEC can check the status of your application with the FCC by computer and, if it's been processed, give you your call sign over the telephone. Alternatively, you can call the FCC yourself at 800-322-1117, although the line is frequently busy because of high call volume.

As soon as you write down your new call sign on a handy piece of paper, you can fire up your rig and get on the air (although you might want to pause briefly to come up with call sign phonetics that sound at least somewhat dignified—before you tell your ham buddies, who will no doubt come up with various unflattering phonetic combinations!).

One thing's for sure: The era of new hams enduring weeks of mental anguish while waiting for their new tickets to miraculously appear in their mailboxes is over. Congratulations on getting your ham ticket!

bly have a window to the outside world to facilitate the routing of feed lines and ground leads (or you can simply cut a hole in the wall and install a PVC "pass-through" conduit, as I did. Landlords, parents and spouses may not see the beauty in this approach, however.

Operating Position Considerations

Even if you don't yet have a rig, it's a good idea to consider the desk or table that will hold all of the radio gear and accessories you'll be accumulating. At a minimum, your station will probably include a transceiver, a microphone, a key or keyer, a logbook, headphones and several publications. Not only must your desk hold all of this stuff (and probably more), you'll need room to "spread out" while operating. Because you'll be spending a fair amount of time there, don't forget good lighting and a comfortable swivel chair.

Antennas, Antennas . . .

Although a detailed discussion of the pros and cons of various antennas is beyond the scope of this column, a few comments are appropriate. You may want to consider putting up some kind of multiband antenna. Statistically, Novices and Techs upgrade quickly, so as long as you're going to the trouble of putting up an antenna in the first place, you might as well be prepared for future operating bands and modes right away. Commercially made multiband antennas are advertised in *CQ*, *QST* and other magazines.

You can make your own multiband antenna, however, if you have simple soldering skills and a few tools. All of the materials can be found at your local hardware store. An excellent source of information on building simple (single-band and multiband) antennas is Doug DeMaw's *Novice Antenna Notebook*, available from the ARRL.

These few ideas should occupy you for the week or two it takes for your ticket and call sign to arrive. Be thankful that Novice and Tech tickets are processed a lot faster than they were 10 years ago! In the bad old days, waiting 6 to 10 weeks for a new license was typical.

Send your ideas, photos, suggestions and requests for club information to me at ARRL Department PCN, 225 Main Street, Newington, CT 06111. See you on the bands. ■

Washington Pulse

FCC ACTIONS AFFECTING COMMUNICATIONS

Digital Data Transmission by Broadcasters

The FCC amended its rules to allow broadcast television licensees to transmit ancillary digital data within the video portion of the standard NTSC television signal. Through the transmission of digital data, broadcasters may provide a wide variety of services including digital newspapers and magazines, low-speed computer data functions, the signaling of "interactive" toys that are responsive to the television signal, and the capability to download computer software and financial data.

The Commission has approved four such transmission methods, stating that they can be used by all broadcast licensees, including low-power television licensees, without prior Commission authorization, and without compromising the essential integrity of the delivered NTSC television picture or causing any other harmful effects on the television viewing public. Licensees will remain responsible for the proper technical operation of their facilities and for curing problems that might arise in using these systems. The Commission stated that the amended rules will allow licensees to provide a wide variety of ancillary communications services useful and valuable to the public and to industry, while helping licensees to raise revenue.

The Commission approved use of the "overscan" methods of ancillary data transmission proposed by Yes! Entertainment Corp. and A.C. Nielsen Co. and the "sub-video" methods proposed by Digideck, Inc. and WavePhore, Inc. Systems using the overscan method function by replacing the transmitted video signal with digitally encoded information in the margins of the picture not normally seen by viewers; sub-video systems distribute the ancillary signals throughout the visible picture in a way that is imperceptible to the viewer. The Commission declined to approve a third, "signal substitution" method proposed in comments by En Technology Corp. ("En"), stating that En would need to provide more information or request an experimental authorization in order for the FCC to consider its system.

The Commission said the authoriza-

tion of these systems is not inconsistent with others' ongoing efforts to develop a national standard recommendation for certain data services, nor may it negatively impact the introduction of digital TV technology. Indeed, the Commission stated that the use of these systems will help broadcasters' transition to digital TV by providing them with experience in digital data transmission and a means of earning station revenue that could be used to develop and implement digital TV facilities. The Commission also stressed that its approval of these systems is based on broadcasters' responsibility to protect the integrity of closed captioning signals.

The Commission stated that the use of these ancillary signals will be considered an elective service, and thus, these services will not be considered broadcasting for the purposes of FCC rules. Ancillary services that are common carrier in nature will be subject to the FCC's common carrier regulation.

Flexible Service Offerings in CMRS

The FCC has adopted rules to allow wireless communications providers, such as cellular, Personal Communications Services (PCS), and paging carriers, flexibility in determining the mix of mobile and fixed services that they will provide to the public. Specifically, the Commission adopted rules that will permit many Commercial Mobile Radio Service (CMRS) providers to use their spectrum to offer fixed services on a co-primary basis with mobile services. As a result, wireless carriers will be able to offer consumers an array of mobile services, fixed services, or combinations of the two, thus encouraging the development of more diverse and innovative service options for the public.

One such innovation likely to be provided in the near future by PCS and other wireless providers is fixed "wireless local loop" services, which will use wireless links to provide telephone service to homes and offices. By developing a wireless local loop, providers will have the potential to compete with wireline telephone companies in the local telephone exchange market. ■

Advertisers Index

A.M.C. Sales, Inc.	36
AOR, LTD.	Cov II
Alpha Delta Communications, Inc.	17
Antenna Supermarket	47
Antique Electronic Supply	20
Antique Radio Classified	20
Arcron-Zeit.....	31
Atlantic Ham Radio	19
BayGen USA.....	53
Byron Hill Publishing Co.....	36
C. Crane Company	37
CRB Research.....	36,79
Cellular Security Group	33
Computer Aided Technologies.....	42,43
Delta Research	23
Drake, R.L. Company	5
Durham Radio Sales & Service, Inc.	79
EDCO.....	13,70,71
Electronic Equipment Bank	1
Firestik Antenna Company	46
Future Scanning Systems	61
GENie Radio & Elec. RoundTable	37
Grove Enterprises, Inc.....	7
ICOM America, Inc.	7
Index Publishing Group, Inc.	57
Jo Gunn Enterprises	21
K & L Technology	75
Lentini Communications, Inc.....	29
MACO Mfg. Div./Majestic Comm.	51
MFJ Enterprises, Inc.	39
Marvel Communications Co., Inc.	79
Metrosoft Corporation.....	46
Microcraft Corporation	61
MoTron Electronics	37
Mouser Electronics	53
Optoelectronics, Inc.....	10,11,Cov. IV
Phillips-Tech Electronics	79
Quement Communications.....	52
R.C. Distributing.....	46,52
REACT International, Inc.....	24
Sams, Howard W.....	47
Scrambling News	61
Signal Engineering, Inc.	12
Software Systems Consulting	23
Stridsberg Enginerring, Inc.	75
Universal Radio, Inc.	3
Viking International	14
Wilson Antenna, Inc.....	19
Wireless Marketing Corp.....	49
Xandi Electronics, Inc.....	12
Yaesu U.S.A.....	Cov. III

Reach this dynamic audience with your advertising message, contact Don Allen, W9CW at 217-344-8653, FAX 217-344-8656, or e-mail: PopComAds@aol.com

Readers' Market

Advertising Rates: Non-commercial ads are 30 cents per word, including abbreviations and addresses; minimum charge \$6.00 per issue. Ads from firms offering commercial products or services are \$1.00 per word; minimum charge \$20.00 per issue. Boldface words are \$1.20 each (specify which words). Leading key words set in all caps at no additional charge. All ads *must be prepaid in full* at time of insertion; a 5% discount is offered for prepaid 6 time insertions. All ads must be typewritten double spaced.

Approval: All ad copy is subject to Publisher's approval and may be modified to eliminate references to equipment and practices which are either illegal or otherwise not within the spirit or coverage scope of the magazine.

Closing Date: The 10th day in the third month preceding date of publication. Because the advertisers and equipment contained in Readers' Market have not been investigated, the Publisher of *Popular Communications* cannot vouch for the merchandise listed therein. Direct all correspondence and ad copy to: PC Readers' Market, 76 N. Broadway, Hicksville, NY 11801, Attn: Nancy Barry.

CB MODIFICATIONS! 10M, frequencies, sliders, FM, amplifiers, books, plans, kits, high-performance accessories. The best since 1976. Find out why! Catalog \$3. CBC INTERNATIONAL INC., Box 31500A, Phoenix, AZ 85046.

NEW AWARDS PROGRAM! For SWL's, DX'ers, Scanner Buffs! Self-addressed stamped envelope brings details! ISWAC, Box 66, Hanover, MI 49241.

FM MICRO BROADCASTING: Transmit many miles. PLL mono/stereo. 88-108 MHz. Kit or assembled. 1-100 W.R.F. amps. Call (250) 642-2859. R. Scott Communications.

TUNE In On Telephone Calls! New 3rd Edition, by Tom Kneitel. Latest freqs., info., and effective scanner accessories for serious recreational eavesdropping on cellular, 46 and 900 MHz cordless, air/ ground phones, digital pagers and more. The original, official, controversial 160-page source book, now updated! Only \$16.95, plus \$5 s/h (\$6 to Canada). NY State residents add \$1.81 tax. Order from your favorite dealer or CRB Research Books, Inc., P.O. Box 56, Commack, NY 11725. MC/VISA accepted. Phone orders: (516) 543-9169.

CABLE DESCRAMBLER! Build for \$12 with seven RadioShack parts. Instructions \$8. F.A.S.T., Box 369-U74, Pt. Salerno, FL 34992-0369.

"FORBIDDEN SECRETS OF THE LEGION OF DOOM HACKERS!" Big 224-page handbook. The infamous LOD's condemned programs and amazing techniques, from the LOD's now shut down in BBS. Hacking, phreaking, and more! Hard to locate information, now in this Limited edition. For reference and informational purposes only. \$20.95, plus \$5 s/h (Canada \$6). NYS add \$2.21 tax. VISA/MC okay. CRB Research Books Inc., Commack, NY 11725. Phone orders: (516) 543-9169.

VHF AERO SCANNER GUIDE: Kneitel's Air-Scan, sixth edition. Great new edition of the new comprehensive and popular USA/Canada VHF aero band directory ever published: Civilian, Military, Private Airports, Helipons & Seaplane Bases, Control Towers, ARTCC, Weather, Approach/Departure, FSS, Ground Control, ATIS, Unicom, National & Air National Guard freqs., etc. Many listings for airport security, fire/rescue, airline ground services & more beyond the aero band. One "must have" guide to tens of thousands of aero related monitor frequencies! Only \$18.95, plus \$5 s/h (\$6 to Canada) from CRB Research, P.O. Box 56, Commack, NY 11725. VISA/MC accepted. Phone orders: (516) 543-9169. (NYS res. add \$2.04 tax.)

SCANNER MODIFICATION HANDBOOK VOL.1 by Bill Cheek. The famous original 160-page books. Performance improvement modifications. Simple step-by-step instructions, many photos. Primarily PRO-2004 & PRO-2005, some for PRO-34, BC-200/205XLT, BC-705XLT, BC-705XLT. Restore blocked-out bands, speed up scanning rate, disable "beep," increase number of channels, improve squelch action, add an S-meter, interface with shortwave receivers, etc. Make the PRO-2004 & 2005 into a 6,400 channel scanner; put 3,200 channels into the PRO-34! Plus, cellular frequency charts, antenna info & mods, inside info on frequency management, operating hints, emergency power supplies, scanners & the law. Lots more! Only \$18.95, plus \$5.00 s/h (Canada \$6). Residents of NY State add \$2.36 tax. Big 220 page **VOL. 2** with more mods for PRO-2004/ 5/6, PRO-34, PRO-2022, BC-760/950XL, BC200/ 205XL, also available. \$18.95 plus \$5.00 s/h (Canada \$6). NY State residents include \$2.36 tax. **NEW! The Ultimate Scanner, VOL. 3.** Giant 240-page edition. Many more mods! Picks up where the first two books ended. \$29.95 plus \$5 s/h (Canada \$6), residents of NYS add \$2.97 tax. Order from CRB Research Books, Inc., PO Box 56, Commack, NY 11725. Visa/MC welcome. Tel: (516) 543-9169.

RADIO SHACK SCANNERS LOWEST PRICES all catalog items. NEW-FRS 105 Family Radio Service 2-way HT reg. \$180—OUR PRICE \$150. Join our buying club and save. No tax. Call 1-800-848-3004 (orders only). **COTRONICS, Inc.**, 2250 S.E. Federal Hwy., Stuart, FL 34994.

MORSE CODE Got You Down? Why let a mental block stand between you and upgrading? Use Alternative Art's **CW Mental-Block Buster** to blast through those barriers. Just follow the instructions for 30 days—Results Guaranteed! Based on 40 years of research, the **CW Mental-Block Buster** uses guided meditation, dynamic visualizations, and powerful affirmations to blast through mental blocks. **You can do code!** That means new bands, more contacts, more fun! (This is not a CW practice tape.) The CW Mental-Block Buster audio cassette and practice booklet are only \$25.95 ppd. in the US. **Alternative Arts**, 4601 Rosemare Rd., Parkersburg, WV 26101. (304) 422-2767. MC/VISA. C.O.D. Mail orders include signature. Office hours after 4:30 Eastern.

DX TOOLS for the serious radio listener. Quantum Loops, Q-Sticks, more. Stamp for catalog. Radio Plus+ Electronics, 3635 Chastain Way, Pensacola, FL 32504. (904) 434-3635.

CB RADIO HACKER'S GUIDE! Big 151 page book; pictorials, diagrams, text. Complete guide to peaking, tweaking, & modifying 200+ CB radios for enhanced performance & more features. Which screws to turn, which wires to cut. AM & SSB radios: Cobra, Courier, GE, Midland, Radio Shack Realistic, SBE, Sears, Uniden/President. Get the most from your CB radio & operations. Only \$19.95, plus \$5.00 shipping (\$6.00 to Canada). NY State residents add \$2.12 tax. Order from CRB Research Books, Inc., PO Box 56, Commack, NY 11725. Visa/MC OK. Tel: (516) 543-9169.

TOMCAT'S BIG CB HANDBOOK, by Tom Kneitel. 221 large pages, fully illustrated. Complete guide to worldwide AM, SSB, Freeband, 27 MHz operations. Everything they never told you (legal & otherwise) from world's leading CB authority. Only \$15.95 plus \$5.00 s/h (Canada \$6.00) from CRB Research Books, Inc., PO Box 56, Commack, NY 11725. (NYS residents add \$1.78 sales tax). Visa/MC orders call: (516) 543-9169.

WORLD'S MOST UNUSUAL Communications Books! A large selection of outstanding titles covering scanners, "confidential" frequency registries, bugging, wire tapping, electronic surveillance, covert communications, computers, espionage, monitoring, and more! New titles being added constantly! Ask for our big FREE catalog. CRB Research, BOX 56-PC, Commack, NY 11725.

CB MODIFICATION SECRETS, big new 200-page guide by Kevin Ross, author of "CB Radio Hacker's Guide." More great easy-to-do Am/SSB CB equipment upgrades and enhancements applicable to Cobra, Realistic, Uniden, President, etc. Freq. expansion, VFO, clarifier unlock, VOX, Roger Beep, anti-theft device, receive signal preamp, much more. Only \$21.95, plus \$5 s/h (\$6 to Canada) from CRB Research Books, P.O. Box 56, Commack, NY 11725. NYS residents add \$2.22 tax. VISA/MC orders call: (516) 543-9169.

MILITARY RADIOS: Easily made battery adapters for military radios & other electronics. Get **POWER UP!** Big new 96-page manual of instructions, diagrams. Use readily available commercial batteries in PRC-6, -8, -9, -10, -25, -28, -47, -74, -77, TRC-77, AN/PRC-9, AN/PRT-4, RT-77, URC-68, more; also mine detectors, night scopes, radiacs, field telephones, etc. Only \$14.95, plus \$5 s/h (\$6 Canada). NYS residents add \$1.53 tax. CRB Research Books, Box 56-PC, Commack, NY 11725. VISA/MC accepted. Phone (516) 543-9169.

CW Lite is the easiest Morse Code training method in the world, bar none! And it is the fastest, too. Just closed your eyes and relax. This powerful **hypnosis cassette tape** does the rest. Subliminals speed you along! Only \$15.95 ppd in US Order today! **Alternative Arts**, 4601 Rosemare Rd., Parkersburg, WV 26101. (304) 422-2767. MC/VISA, COD. Mail orders include signature. Office hours after 4:30 Eastern.

NOW YOU CAN DEAL DIRECT WITH THE 'SHED! We only deal with CB's—We have to be good! The CB Shed, P.O. Box 565, Chouteau, OK 74337; 918-476-8656.

CW? NO PROBLEM. You can increase your speed, no matter how many times you've failed before. **Results guaranteed** when you follow the instructions. **Alternative Art's CW Mental-Block Buster** program helps you **explode mental blocks** that hold you back. Based on 40 years of research, the **CW Mental-Block Buster** uses guided meditation, dynamic visualizations, and powerful affirmations to blast through mental blocks. You can do code! That means new bands, more contacts, more fun! (This is not a CW practice tape.) The CW Mental-Block Buster audio cassette and practice booklet are only \$29.95 ppd. in the US. (Quantity discounts available for classes.) **Alternative Arts**, 4601 Rosemare Rd., Parkersburg, WV 26101. (304) 422-2767. MC/VISA, COD. Mail orders include signature. Office hours after 4:30 Eastern.

WANTED: RADIO SHACK PRO-39 RADIOS, working condition, top dollar. Jude (415) 652-4898.

WANTED: CB RADIO EQUIPMENT—I'm looking for all types of old/vintage CB radios, amps, manuals, magazines, mics, etc. **PLEASE CALL** anytime. **WALTER** 818-297-7249.

GE SUPERADIO III with up to four SCS bands is the DX'er's choice. AM modification included. Low as \$85. 800-944-0630.

CABLE DESCRAMBLERS FROM \$99.00. TEST DEVICES FROM \$15.00. CALL US WITH YOUR QUESTIONS. 1-800-449-9189. NO FLORIDA SALES. ANYONE IMPLYING THEFT OF SERVICE WILL BE DENIED ASSISTANCE.

MILITARY TECHNICAL MANUALS for sale. Basic Electricity, Basic Electronics, Antenna Theory and mechanical books. Write or call for listing: **ART'S BOOK WORLD, INC.**, 6822 22nd Ave. N., Ste. 175, St. Petersburg, FL 33710; phone 813-525-4880; or TOLL-FREE 1-888-414-BOOK.

NEED HELP! Radio Shack can't repair/replace band switch and FET amp on analog geezer's like-new Realistic DX-200. Can anyone? Joseph Burgess, 407 Hiawatha, Frankfort, KY 40601. (502) 695-3016.

RC-740X band expansion for **KENWOOD 741/742** series. **ScannerWEAR WINDOWS** software for **ICOM, AOR, Opto** receivers see all at <http://www.radioscan.com>. **RADIO CONTROL SYSTEMS, INC.**, 1-800-560-7234.

CABLE TV DESCRAMBLER. Build your own. Complete plans. Parts list. Diagrams. Circuit board. Schematics. Send \$9.95 to A. Gray, P.O. Box 1223-E Station 28, Route 6, Halifax, NS B3L-4P4.

CABLE TV DESCRAMBLER!! ANYONE CAN BUILD IN SEVEN EASY STEPS WITH RADIO SHACK PARTS. PLANS/KITS FROM \$5.00 PLUS FREE BONUS. 1-800-818-9103.

RADIO STUFF SALE: Books, magazines, club bulletins, radio station items, old time radio & more. \$1 for list. G. Dexter, 213 Forest St., Lake Geneva, WI 53147.

CABLE DESCRAMBLER anyone can build for under \$12 in 7 easy steps with Radio Shack parts! Plans \$10. R.L. International, 12917 Jefferson Ave., Suite H-162, Newport News, VA 23608.

WANTED: TUBE-TYPE audio equipment, speakers, 1930's-1960's. Microphones, amplifiers, mixers, etc. Western Electric, Macintosh, Marantz, Altec, J.B.L., etc. **1-800-251-5454.**

HAMFEST. TRENTON, NJ. March 23, 1996. TCL picnic grove. Setup 6:30 AM, open 8:00 AM. Admission \$5.00, tailgating \$10.00, covered space and table \$15.00. Talk-in 146.67 (-). Hamcomp '97, DVRA, PO Box 7024, West Trenton, NJ 08628. 609-882-2240. <http://www.voicenet.com/~acelog>.

LEARN MORSE CODE IN 4 HOURS! Taught the military method. Send \$9.95 to: J.L. Steiger, 375 Hillside, Seven Hills, OH 44131.

SERVICE AND MODIFICATION HANDBOOKS: Cobra, Uniden, RCI, Galaxy, Motorola. CB/HAM/MARINE/COMMERCIAL Radios, antennas, mics, meters, and accessories. Plus Night Scopes and Tons more stuff. 28 pg. Catalog \$3.00. **MAX-TECH**, Box 8086, New York, NY 10150 USA; 718-547-8244.

CB RADIOS, SPECIALTY items, police, fire scanners, exotic electronic items, power supplies, RF power meters, microphones, more!! Picture price sheets only \$1.00 refundable. **GALAXY ELECTRONICS**, Box 1202, Akron, OH 44309... Our 13th Year!

CABLE DESCRAMBLERS—BELOW WHOLESALE PRICES ALL BRANDS, 30 DAY MONEY-BACK GUARANTEE ABSOLUTELY THE LOWEST PRICES—NOBODY BEATS US. THE CABLE STORE 1-800-390-1899.



Combination Antenna FM/CEL-1 6db Gain Cellular-AM/FM-Weatherband Antenna Kit

EVERHARDT ANTENNAS introduces its newest multi-purpose antenna design that combines 6db gain cellular, AM/FM and Weatherband on one antenna. This allows an installer to use one antenna, route one cable, and supply four different frequencies to a vehicle while using the existing cowl or roof mount AM/FM antenna hole. The supplied duplexer filters and separates the appropriate signals and has 3' of cable to route to the radio and transceiver. Features include 6db gain co-linear antenna for maximum performance, Weatherband "TRAP" for AM/FM radios with Weatherband feature, 90" low loss RG-58C/U from antenna base to duplexer box, adjustable mounting base from 1/8" to 3/4", 3-foot RG-62 AM/FM cable with male Motorola plug and 3-foot RG-58C/U cellular cable with TNC connector.

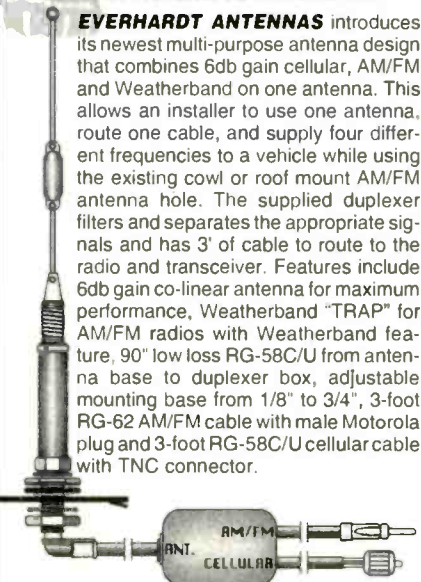

EVERHARDT ANTENNAS
6000-D Old Hemphill Road
Fort Worth, TX 76134
800-735-0176
CIRCLE 76 ON READER SERVICE CARD

Scanner Buffs We've Got The Goods!
We have a great selection of full-coverage scanners including AOR, Radio Shack, Trident and Vuplter. We also carry scanner interfaces for the ultimate scanning experience!

- 1000 channels (20 banks of 50 channels)
- full coverage from 500KHz-1.9GHz AM-WFM-NFM-U/LSB-CW
- scans a maximum of 30 channels/sec
- comes with rubber duck ant. nicads, charger, lighter plug, more.

Send \$3.00 for our new 68 page catalog

AOR AR8000

Durham Radio Sales & Service, Inc.
350 Wentworth St. E., Oshawa, Ont. L1H 7R7
Ph: (905)436-2100 Fax: 436-3231
Web: durhamradio.ca e-mail: info@durhamradio.ca

YOU AIN'T HEARD NOTHIN'... YET

Since 1967, CRB Research has been the world's leading publisher and supplier of unique hobby and professional books and information including:

- Scanner Freq. Guides
- Military/Federal Comm.
- Broadcast Station
- Undercover Communications
- Registries
- Shortwave Freq. Guides
- & Other Related Topics!

Ask for our latest FREE catalog.

CRB RESEARCH
P.O. Box 56, Commack, NY 11725
Ph: (516) 543-9169 FAX: (516) 543-7486
e-mail: crbbooks@aol.com

CIRCLE 11 ON READER SERVICE CARD

Quality Microwave TV Systems
WIRELESS CABLE - ITFS - MMDS
ATV - INTERNATIONAL - S-BAND
Amplifiers • Antennas • Books • Components
Filters • Systems • Video Products

- RF Frequency 1990 - 2700 MHz
- Cable Ready - VHF - UHF Outputs
- SASE For "FREE" Catalog or Send \$1

PHILLIPS-TECH ELECTRONICS
PO Box 8533 • Scottsdale, AZ 85252
ORDER LINE 800-880-MMDS
CATALOG/INFO 602-947-7700
FAX LINE 602-947-7799
Visa • M/C • Amx • Disc • COD's • Qty Pricing

CHALLENGER SYSTEM
33-Channel 52dB+ Gain
Complete Grid \$265
Five Year Warranty
FREE SHIPPING

The Loose Connection

RADIO COMMUNICATIONS HUMOR

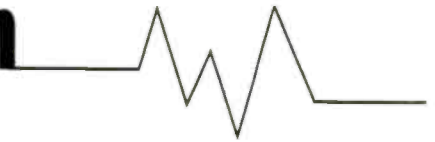

Honest, Officer . . .

Regardless of when you read this, today is a cold, crisp day on North Carolina's Outer Banks. As I write, a stiff wind blows, and NOAA warned last night that today may be this year's coldest day on these barrier islands. In all fairness to my editor, Harold "I suppose you'll want all of Christmas Day off too" Ort, when I inquired about this brief working-vacation, he warned me that the weather might not be conducive to seaside writing. "Nonsense," I scoffed. "We're talking about the Carolinas, man. It doesn't get cold down there—it's in the south!"

The NiCd batteries in my laptop computer, which normally give me a couple hours operating time, refused even to spin the hard drive as I sat on a bench atop the dunes. No matter; my breath had frosted over my glasses anyway and the mittens—well—I'm sure you get the picture. I am now back at our beautiful vacation retreat soaking my feet in hot cocoa. My laptop computer is now thawing—spinning on the carousel with the microwave set on "defrost."

Don't worry—I wrapped it in foil to protect the circuitry.

I was smart enough to bring my scanner along on this trip. The VHF marine frequencies—particularly channel 16—yield a constant source of interesting chatter for this former Coastie turned landlubber. The towns here are so quiet in the off-season that the only police activity last night was two routine traffic-stops and one "mopery with intent to gawk." It was just after the mopery incident that I noticed my high-rate NiCds were running down. It turned out that the AC adapter I hastily packed was for an old answering machine—not my scanner. A kind young manager at the Kitty Hawk RadioShack store assured me he'd remain open 'til I could find his store. You can never have too many AC adapters.

I am writing during the first weekend after the great "Newt-Scanning" incident. Since whatever I write will be cast in stone by the typesetters until you read these words in April, it's as if my prediction will be held in quarantine as the inci-

dent unfolds. If my comments are off base, you'll be laughing at me, but since this page is supposed to make you laugh, I might as well hope I'm wrong. If I'm right, perhaps the great newspaper editors will steal me away from Harold "Par-simonious" Ort and offer me a well-paid position as a syndicated scanner-pundit.

I remember reading within the past year of a police officer using a cell phone from the site of some incident. While using his phone, the officer observed a reporter listening to the cell phone conversation on a scanner. The officer arrested the reporter on the spot. I don't know exactly what the charge was, but the arrest was made, so a precedent for arresting a cell phone eavesdropper already exists. It would indeed be interesting to learn the disposition of that case, and that case may be precedent-setting if the Newt-Gate eavesdropping ever comes to trial, but it is my humble opinion that anti-cell phone eavesdropping statutes (the Communications Act, the Communications Privacy Act, Florida statutes regarding scanner use in motor vehicles, et al) only apply to you and me. How I hope I'm wrong.

So now a political operative in Florida happened to have a scanner in his vehicle, happened upon a political conference call, happened to have a tape-recorder at the ready (tell me when this becomes hard to swallow), has made public statements in which he admitted to eavesdropping on a cellular phone conversation while in a vehicle in Florida, has provided evidence (the tape) of doing so, and has not (as I write) been charged with a felony, a misdemeanor, or even Florida's least-serious secondary offense, a no-no.

"Honest, officer—I was taking my scanner in to have it serviced. Did I mention I was taking my tape recorder in as well? Imagine my surprise when I was rear-ended at a stoplight, and the scanner and the tape recorder came slamming through the rusted trunk of my '74 Nova, turned themselves on and connected themselves. As to the modification to allow my scanner to receive cellular phone frequencies, I can only imagine

that a small, extremely selective static discharge struck my scanner in such a way that a modification occurred. Yes, sir, I would normally find that a bit hard to believe, but the impact of the collision seems to have clouded my memory.

"No, sir—those are fresh dents. Well, that one is, over there, anyway. Yes, recording from that scanner does require a bit of preparation, what with the proper audio cables and plugs and all. No, I think I had those cables in the trunk because I used them to tie the trunk shut. No, I had no idea they'd fit the recorder and the scanner. No, I'm afraid the collision has clouded my memory on that."

Over the past few days I have heard evening and late-night radio talk-shows featuring "experts" with the most horrendous assumptions regarding communication law, along with some of the worst information regarding scanners, frequencies, modifications, regulations, and wiretapping. I even heard the editor of a personal-privacy magazine say it was OK to eavesdrop on a cellphone call so long as you immediately turned the tape over to a police officer, but probably the worst thing I heard was the repeated question, "What's wrong with these scanner people anyway? Are they a bunch of sick eavesdroppers who have no lives?"

I got two reactions to that. The first, was, "Hey—those are *my readers* this bimbo's calling sick. What's wrong with this talk-show host that she doesn't have a scanner? Does she have no life?"

The second reaction I got was that none of our readers seemed to take part in these call-in shows. I was waiting to hear an avid scanner hobbyist call, but it's clear that no one who's ever cracked the covers of *Pop'Comm* would have made the absurd statements I heard callers make on these shows, and I was surprised that no *Pop'Comm* readers called to set the hosts, their guests, and their other callers straight. In case you're wondering why I didn't call any of these shows myself, it's because they were all on during evening drive time (I drive the late commute), and I didn't want any *scanner-people* listening to me on my cell phone! ■

Ultra Compact Dual Band Handheld **FT-50R**

One tough little dual bander!

Features

- Frequency Coverage
Wide Band Receive
RX: 76-230 MHz, 300-540 MHz 590-999 MHz*
- TX: 144-48 MHz, 430-450 MHz
- AM Aircraft Receive
- MIL-STD 810 Rating
- Digital Coded Squelch (DCS)
- 112 Memory Channels
- 12V DC Direct Input
- High Speed Scanning
- Alpha Numeric Display
- CTCSS Encode (Decode w/FT-12)
- Auto Range Transpond System™ (ARTS™)
- Dual Watch
- Direct FM
- High Audio Output
- ADMS-1C Windows™ Programmable
- Four Battery Savers:
Automatic Power-Off (APO)
Receive Battery Saver (RBS)
Selectable Power Output (SPO)
Transmit Battery Saver (TBS)
- Time Out Timer (TOT)
- 2.5 and 5 Watt Versions Available
- Optical Digital Voice Recording System (DVRS)
- Full Line of accessories



"You notice how loud this HT's audio is?"

"Yeah, it's Mil Spec tough like a commercial HT."



"Easy to operate, small, great price!"

"Yaesu did it again!"

For the foremost in top-performing, durable, dual band handhelds there is one choice. The FT-50R. Manufactured to rigid commercial grade standards, the FT-50R is the only amateur dual band HT to achieve a MIL-STD 810 rating. Water-resistant construction uses weather-proof gaskets to seal major internal components against the corrosive action of dust and moisture. And, the rugged FT-50R withstands shock and vibration, so throw it in with your gear!

Dynamic and exclusive features set the FT-50R apart, too. Wide Band Receive includes 76-200 MHz (VHF), 300-540 (UHF), and 590-999 MHz*. Dual Watch checks sub-band activity while receiving on another frequency, then when a signal is detected, shifts operation to that frequency. Digital

Battery Voltage displays current operating battery voltage. Digital Coded Squelch (DCS) silently monitors busy channels. Auto Range Transpond System™ (ARTS™) uses DCS to allow two radios to track one another. And, the FT-50R is ADMS-1C Windows™ PC programming compatible, too. To round out the FT-50R, it has four battery savers, and super loud audio—remarkable in an HT this size.

A reliable companion where ever you go, the FT-50R is one tough little dual bander with all the features you want!

YAESU
...leading the way.SM

For the latest Yaesu news, hottest products, visit us on the Internet! <http://www.yaesu.com>



FT-10/40R
Ultra Compact Handhelds
VHF or UHF. Similar to FT-50R including MIL-STD 810, and other exclusive features.

Reaction Tune the
NEW
ICOM IC-R10

iCan Reaction Tune Another Receiver!

Use the OptoLinx for computer controlling the ICOM IC-R10 \$129.00



Computer Not Included

Scout's unique functions. Scanner hobbyists and communication professionals benefit from the *Scout's* unique functions. Whether you're searching for new frequencies in your neighborhood, or testing for interference, the *Scout* is the ultimate communications tool.

Armed with a 400 frequency memory register, the *Scout* does not record duplicate frequencies, instead it coordinates repeated frequencies into a hit register storing up to 255 hits per frequency. Attach it to your belt and begin your day, the *Scout* will alert you when a signal is received by its beeper or vibrator function.

You won't miss a thing with Reaction Tune. The *Scout's* CI-V compatible output allows it to interface to the AOR AR2700/AR8000, ICOM R7000, R7100, R8500, R9000 and now the new IC-R10 (shown opposite). The *Scout* captures the frequency, then sends the serial data to the receiver and tunes the scanner to the frequency for instant monitoring in less than one second. Recorded frequencies can be downloaded to a PC using the optional OptoLinx universal interface •

SPECIFICATIONS

- ▶ 10MHz - 1.4GHz frequency coverage
- ▶ Stores and records 400 frequencies in memory with 255 hits for each
- ▶ Interface to a PC for frequency download using optional OptoLinx PC interface
- ▶ Distinctive beeps indicate frequency hits, pager style vibrator for discreet recording
- ▶ Automatic EL backlight for night operation
- ▶ 16 segment RF signal strength bargraph
- ▶ Frequencies are automatically saved when unit is turned off
- ▶ Reaction Tune the ICOM R7000, R7100, R8500, R9000, IC-R10, and AOR AR2700, AR8000, and the Radio Shack Pro 2005/6 using the Optoelectronics OS456, Radio Shack Pro 2035/42 using the Optoelectronics OS535



U.S. Patent No. 5,471,408

Radio Not Included

\$449
Includes Scout, DB32 Antenna, CC3 Case & Spectrum CD

Scout with ICOM IC-R10
Mono Cable required (shown)

FACTORY DIRECT ORDER LINE 800-327-5912

OPTOELECTRONICS®

INNOVATIVE PRODUCTS FOR A MODERN PLANET

5821 NE 14th Avenue • Ft. Lauderdale, FL • 33334

Telephone • (954) 771-2050 Fax • (954) 771-2052

CIRCLE 152 ON READER SERVICE CARD

Visa, Mastercard, C.O.D. Prices and specifications are subject to change without notice or obligation



The ICOM logo is a registered trademark of ICOM Inc. ICOM IC-R10 not distributed by OPTOELECTRONICS, contact ICOM for information and availability.