

# QST

DEVOTED ENTIRELY TO

# AMATEUR RADIO

*Published by the American Radio Relay League*



JULY  
1926

25¢

# Cunningham

## RADIO TUBES

Since 1915—  
Standard for all Sets



## Ceaseless Effort

to improve the quality of radio reception has had one sure result. Today—thanks to this effort—Cunningham Radio Tubes have won a reputation and a confidence which are reflected in their popularity. "Since 1915—Standard for all Sets," is far more than a slogan; it is a clear statement of absolute fact.

## All Types C-&CX---

In the Orange and Blue Carton

*E. J. Cunningham Inc.*

New York

Chicago

San Francisco

Manufactured and sold under rights, patents and inventions owned and / or  
controlled by Radio Corporation of America

# Rauland=Lyric=Trio

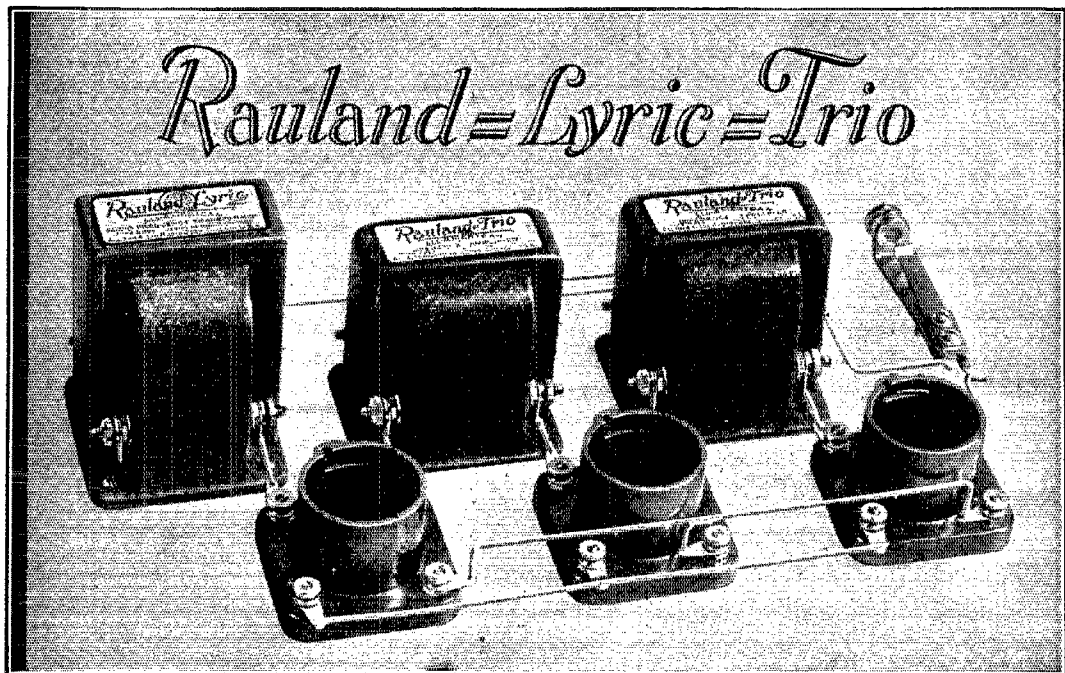

## *A remarkable improvement in audio amplification*

*New unit perfected by All-American Engineers gives you the  
full, pure, natural tone you have always sought*

**Y**OU have always wanted the ideal result in audio amplification—pure, natural tone with good volume. The laboratories of All-American Radio Corporation have developed a new method of audio amplification and now bring to you this long sought ideal result in the—

### *Rauland=Lyric=Trio*

You know the Rauland-Lyric transformer. Its exceptional tone perfection has made it the largest selling quality transformer in the world. The Rauland-Lyric is now used in combination with the new Rauland-Trio (impedance units) to produce the Rauland-Lyric-Trio amplifier—the highest known perfection in three stage audio amplification.

It is well known that any system of amplification using instruments of similar characteristics has inherent disadvantages. Rauland-Lyric-Trio successfully combines the two leading systems—transformer and im-

pedance coupling—coordinated to retain the advantages of both and to eliminate their weaknesses.

This new method consists of a Rauland-Lyric transformer for the first stage, a Rauland-Trio Type R-300 impedance for the second stage, and a Rauland-Trio Type R-310 impedance for the third stage.

### *Rauland=Trio*

This is a triple feature instrument containing an inductance, a capacity and a resistance in one compact impedance unit. Through laboratory tests of utmost precision, absolutely correct balance is maintained between these important factors. You secure full advantage of impedance amplification and overcome the common variance of commercial types of condensers and resistances. Rauland-Lyric-Trio is the last word in audio amplification.

*A free book, "Modern Audio Amplification," tells more about this interesting new development. Write for handbook B-90.*



ALL-AMERICAN RADIO CORPORATION  
4217 BELMONT AVE., CHICAGO, U. S. A.

*Station WENR—266 Meters—is owned and operated by the All-American Radio Corporation*

# BONE DRY

Operates from  
105-125 volts  
50-60 cycles  
charges both 4  
and 6 volt bat-  
teries.

The *ELKON*  
Rectifier  
(Solid throughout)

A Transformer  
A Switch

That is all there is to the

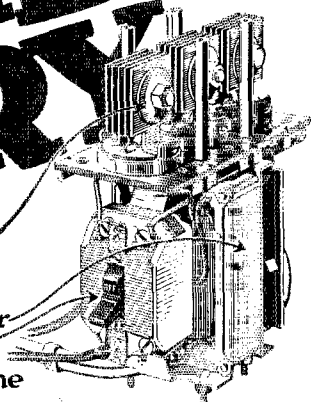

## ELKON TRICKLE CHARGER

The Elkton Rectifying unit consists of nothing but plates and discs bolted together into a rigid unit. By means of unilateral conductivity it makes possible the charging of Radio "A" batteries direct from alternating current.

WITHOUT

ACIDS

ALKALI

WATER

TUBES

MOVING PARTS

CORROSIVE VAPORS

INTERFERENCE

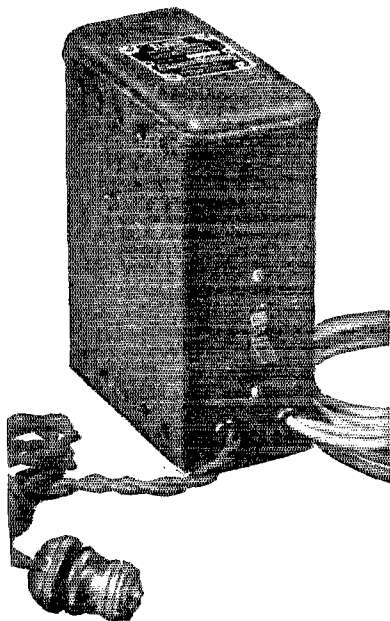

There is nothing delicate about the rectifying unit—it functions in any position, at any temperature.

There is nothing complicated about the Trickle Charger.

**SET IT—INSTALL IT—FORGET IT**

It keeps "A" batteries automatically replenished without attention. It tapers and increases as needed to keep the batteries at maximum efficiency.

\$15.00 Complete with switch.

For sale at radio dealers or write.

**ELKON WORKS**  
Subsidiary of P. R. Mallory & Co. Inc.  
Weehawken, N. J. Inc.

# THE COMMUNICATIONS DEPARTMENT, A. R. R. L.

A.D.M. D. of C.  
A.D.M. Maryland  
A.D.M. So. N. J.  
A.D.M. West. N. Y.  
A.D.M. East. Pa.  
A.D.M. West. Pa.  
A.D.M. Delaware

5AB  
5HG  
5EH  
5PJ  
5PM  
5ZD  
5AIS

Manager  
A.D.M. Michigan  
A.D.M. Ohio  
A.D.M. Illinois  
A.D.M. Wisconsin  
A.D.M. Indiana  
A.D.M. Kentucky

5ZZ  
5ZE  
9AAV  
9VD  
9CJQ  
9EL

Manager  
A.D.M. Minnesota  
A.D.M. So. Dak.  
A.D.M. No. Dak.

9ZT-9XAX  
9EGU  
9CIS  
9EPN

Manager  
A.D.M. Mississippi  
A.D.M. Arkansas  
A.D.M. Tennessee  
A.D.M. Louisiana

4MM  
5AKP  
5XAB  
4KN  
5UK

Manager  
A.D.M. No. N. J.  
A.D.M. N. Y. C.  
A.D.M. East. N. Y.

5BR  
3WR  
3CWR  
2PV

Manager  
Asst. Secy. to DM.  
A.D.M. Iowa  
A.D.M. Missouri  
A.D.M. Kansas  
A.D.M. Nebraska

9DXY  
9ABZ  
9RR  
9CDS  
9CJT

Manager  
A.D.M. R. I.  
A.D.M. N. H.  
A.D.M. Vermont  
A.D.M. W. Mass.  
A.D.M. E. Mass.  
A.D.M. Conn.  
A.D.M. Maine

1AVW  
1BYE  
1GL  
1AJJ  
1ASU  
1KY  
1RM  
1UU

Manager  
A.D.M. Montana  
A.D.M. Wash.  
A.D.M. Oregon  
A.D.M. Idaho  
A.D.M. Alaska

7EK ex 7ABB  
7NT  
7FD  
7TP-XAF  
7OB  
7DE

Mgr. Southern Section  
A.D.M. Dist. 1, 2, 3  
A.D.M. Ariz.  
Mgr. Northern Section  
A.D.M. Dist. 4  
A.D.M. Dist. 5  
A.D.M. Dist. 6  
A.D.M. Nevada  
Mgr. Hawaiian Section  
A.D.M. Hawaii

6BUR  
6CBZ  
6AND  
6ZX  
6NX  
6BIP  
6RAF  
6HU  
6TU  
6BCG

Manager  
A.D.M. West Va.  
A.D.M. Virginia  
A.D.M. No. Carolina

8BZ  
8BSU  
3CA  
4JR

Manager  
A.D.M. Colorado  
A.D.M. Utah

7ZO  
9CAA  
6ZT

Manager  
A.D.M. S. C.  
A.D.M. Alabama  
A.D.M. Florida  
A.D.M. Georgia  
A.D.M. Porto Rico

5AJP  
4RR  
5AX  
4GY  
4FO  
4OI

Manager  
A.D.M. Oklahoma  
A.D.M. So. Texas  
A.D.M. No. Texas

5ZC  
5APG  
5YK  
5AJT

Manager  
A.D.M. P. E. I.  
A.D.M. N. B.

1DD  
1BZ  
1BI

Manager  
A.D.M. Cen. Ont.  
A.D.M. East. Ont.  
A.D.M. So. Ont.  
A.D.M. No. Ont.

9BJ  
3VH  
2APP  
5ZB  
3NT

Manager  
A.D.M. Sask.  
A.D.M. Manitoba

3BE  
4GT

Manager  
A.D.M. Sask.  
A.D.M. Manitoba

4DE  
4CB-9BX  
4DE

## ATLANTIC DIVISION

A. E. Goodall  
G. L. Deichmann, Jr.  
H. W. Denham  
C. S. Taylor  
J. F. Rau  
F. E. Wiggin  
H. E. Layton  
C. E. Barr  
F. D. Fallain

1824 Ingleside Ter.  
Chapel Gate Lane  
140 Washington St.  
598 Alaten St.  
1551 So. 58th St.  
514 Johnston St.  
505 Washington St.

Washington  
Ten Hills, Baltimore  
Collingswood  
Buffalo  
Philadelphia  
Wilkesburg  
Wilmington

## CENTRAL DIVISION

W. E. Schweltzer.  
C. N. Crapo  
D. J. Angus  
J. C. Anderson

137 Hill Ave., Highland Pk.  
321 First Ave.  
4264 Hazel Ave.  
443 Newton Ave.  
310 N. Illinois St.  
141ensary Farm

Detroit, Mich.  
Flint, Mich.

Chicago  
Milwaukee  
Indianapolis  
Lexington

## DAKOTA DIVISION

D. C. Wallace  
C. L. Barber  
M. J. Junkins  
George R. Mohr

54 N. Penn Ave.  
520 4th St.

Minneapolis, Minn.  
Hennepin  
Bryant  
N. Fargo

## DELTA DIVISION

B. E. Painter  
J. W. Gullett  
Dr. H. M. Hunter  
L. K. Rush  
O. A. Freitag

124 Hamilton Nat. Bank Bldg.  
819-29th Ave.  
207 1/2 Main St.  
4 Second St.  
8520 Forsney St.

Chattanooga, Tenn.  
Meridian  
Little Rock  
Bemis  
New Orleans

## HUDSON DIVISION

E. M. Glaser  
A. G. Wester, Jr.  
F. H. Marlon  
H. N. Ammeheuser

145 E. 13th St.  
1075 Chancellor St.  
1309 W. Farms Rd.  
178 Quail St.

Brooklyn, N. Y.  
Irvington  
Bronx  
Albany

## MIDWEST DIVISION

P. H. Quinby  
C. B. Diehl  
D. E. Watts  
L. B. Laizure  
C. M. Lewis  
H. A. Nielson

Box 134A, Rt. 6  
3006 S. 22d Ave.  
118 Myland Ave.  
8020 Mercer St.  
212 E. Rutledge St.  
4708 N. 39th St.

Omaha, Nebr.  
Omaha  
Ames  
Kansas City  
Yates Center  
Omaha

## NEW ENGLAND DIVISION

T. F. Cushing  
D. E. Faneuil  
C. P. Sawyer  
C. T. Kerr  
C. V. Green  
Miss Gladys Hannah  
H. E. Nichols  
S. E. Coleman

53 Collice St.  
36 Franklin St.  
11 Stark St.  
6 Airlie St.  
3 Summer St.  
32 Elmwood Ave.  
11 James St.

Springfield, Mass.  
Westerly  
Manchester  
Poultney  
Worcester  
Cambridge  
Bridgeport  
Bangor

## NORTHWESTERN DIVISION

Everett Kiek  
A. R. Wilson  
Otto Johnson  
Ashley C. Dixon, Jr.  
K. S. Norquest  
Leo H. Machin

3802 Hoyt Ave.  
4340 30th West  
1350 East 36th St.  
Weather Bureau  
Box 452

Everett, Wash.  
Ramsey  
Seattle  
Portland  
Boise  
Corvova

## PACIFIC DIVISION

L. E. Smith  
W. S. Weisgraber  
D. R. Lamb  
P. W. Dann  
F. J. Quement  
George Becker, Jr.  
St. Clair Adams  
C. B. Newcomb  
R. A. Ganth  
W. H. Friedly

530 N. Painter Ave.  
R. L. L.  
229 W. First St.  
502-35th St.  
51 Pleasant St.  
2375 Fruitvale Ave.  
St. Clair Adams  
1593 Pihok St.  
1825 Dole St.

Whittier, Calif.  
Whittier  
Mesa  
Oakland  
San Jose  
Oakland  
Eureka  
Yerlinton  
Honolulu, T. H.  
Honolulu, T. H.

## ROANOKE DIVISION

W. T. Gravelly  
C. S. Hoffman, Jr.  
J. E. Wohford  
H. S. Morris

124 Main St., Box 245  
126 Chantal Court  
118 Cambridge Ave.  
413 S. Broad St.

Danville, Va.  
Wheeling  
Roanoke  
Gastonia

## ROCKY MOUNTAIN DIVISION

C. R. Hood  
N. R. Stedman  
Art Johnson

1022 S. Ash St.  
1641 Albion St.  
247 E. 7th South St.

Casper, Wyo.  
Denver  
Salt Lake City

## SOUTHEASTERN DIVISION

A. D. Trum  
A. Duro  
H. S. Bromell  
W. E. Grogan  
J. Morris  
Luis Rexach

217 Catoma St.  
390 Wofford Campus  
Box 731  
Box 816  
58 Frederica St.  
Box 319

Montgomery, Ala.  
Spartanburg  
Birmingham  
Ft. Myers  
Atlanta  
San Juan

## WEST GULF DIVISION

F. M. Corlett  
K. M. Ehret  
W. A. Sahn  
E. B. Forrest, Jr.

2515 Catherine St.  
2904 N. Robinson St.  
Box 569  
302 Royal St.

Dallas, Texas  
Oklahoma City  
New Braunfels  
Waxahachie

## MARITIME DIVISION

W. C. Borrett  
W. Hyndman  
T. B. Lacey

14 Sinclair St.  
c/o N. B. Power Co.

Dartmouth, N. S.  
Charlottetown  
St. John

## ONTARIO DIVISION

W. Y. Sloan  
A. R. Williams  
F. A. C. Harrison  
J. A. Varey  
Wm. Sutton

167 Close Ave.  
56 Madison Ave.  
181 Hopewell Ave.  
43 York St.  
Care of Victoria Hotel

Toronto Ont.  
Toronto  
Ottawa  
St. Catharines  
Ft. William

## QUEBEC DIVISION

Alex Reid

292 Birch Ave.

St. Lambert, Qua.

## VANALTA DIVISION

A. H. Asmussen

223 2nd Ave. N. E.

Calgary, Alberta

## PRAIRIE DIVISION

F. E. Rutland  
E. L. Maynard  
F. E. Rutland, Jr.

452 St. John Ave.  
452 St. John Ave.

Winnipeg  
Morse  
Winnipeg

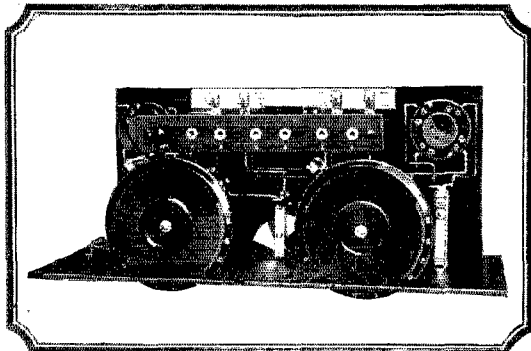

Showing coil mounting and Beat Frequency Condenser between dials.

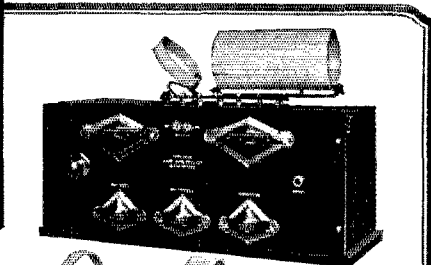

Front view of CR-18 with 200 meter coil intake and additional coils for 10, 20, 40 and 80 meter bands.

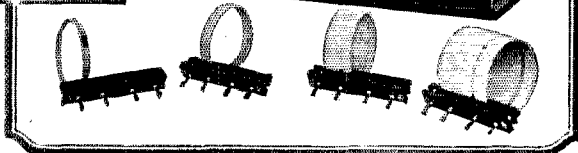

## For the Reception of Frequencies between 1,500 and 30,000 kilocycles

**T**HE new Grebe CR-18 Low-wave Receiver is a modern coupled regenerative circuit adapted for the reception of between 10 and 200 meters. The result of long experience in the making of radio apparatus, it has several outstanding features:

An **Antenna Coupling Coil** which provides variable electro-magnetic coupling between antenna and grid circuit. Permits of harmonic tuning to increase signal strength, gives greater selectivity and reduces interference and induction noises.

**Losses** are reduced to a minimum.

**Plug-in Coils** allow rapid change from one frequency to another.

**Grebe S-L-F Condensers** insure ease

of tuning and maximum signal strength.

**Beat Frequency Control** permits tuning to a fraction of a kilocycle.

**Plate Circuit** gives smooth control of regeneration without affecting wavelength calibration and tuning.

**Cushion Sockets** eliminate microphonic noises.

**Six Self-Supporting Air Dielectric Coils** are instantly interchangeable.

*Write for detailed description of this,  
the last word in low-wave receivers.*

**A. H. Grebe & Co., Inc., 109 West 57th Street, New York**

**Factory: Richmond Hill, N. Y.**

**Western Branch: 443 So. San Pedro Street, Los Angeles, Cal.**



*It is written:*

"A gem is not polished without rubbing, nor a man perfected without trials."

The perfection of the CR-18 has come from past years of ceaseless study and experiment.

*Director H. H.*

THE **GREBE**  
**CR-18**

This company owns and operates stations WAHG and WBOQ; also low-wave rebroadcasting stations, Mobile WGMU and Marine WRMU, and stations 2ZV and 2XE.



All Grebe apparatus is covered by patents granted and pending

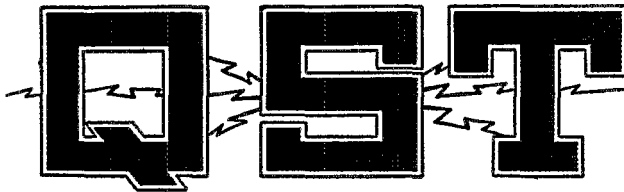

# The Official Organ of the A.R.R.L.

VOLUME X

JULY 1926

NUMBER 7

Editorials		7
Feeding the Antenna	<i>Robert S. Kruse</i>	8
High-Power Transmitting Condensers		14
Quartz Crystal Mountings	<i>John M. Clayton</i>	15
More Arctic Adventure		17
R. F. Chokes		19
Short-Wave Receiving Sets	<i>L. W. Hatry</i>	20
Legislative Notes		26
Information Service Rules		26
"Rotten Radio"	<i>One of the Old Men</i>	27
8GZ Wins Jewell Contest	<i>John H. Miller</i>	28
Transmitting Coils	<i>F. E. Handy</i>	29
Book Reviews		30
Short-Wave Wavemeters		31
Financial Statement		32
A Two-Speed Vernier Dial		32
The Hudson Division Puts it Over		33
Progress and Plans at 5 Meters—and Below	<i>Robert S. Kruse</i>	34
Experimenters' Section Report		38
Omission From 1XM Description		40
Amateur Radio Stations 1AOF, 6OI, a5BG		41
Calls Heard		44
I. A. R. U. News		63
WWV Schedules		65
Correspondence		66
Ham-Ads		91
QRAs		92
Index of Advertisers		94

QST is published monthly by The American Radio Relay League, Inc., at Hartford, Conn., U. S. A.  
Official organ of the A.R.R.L. and the International Amateur Radio Union

Kenneth B. Warner (Secretary, A.R.R.L.),  
Editor-in-Chief and Business Manager

F. Cheyney Beekley  
Managing Editor and Advertising Manager

Robert S. Kruse,  
Technical Editor

John M. Clayton,  
Assistant Technical Editor

David H. Houghton,  
Circulation Manager

Subscription rate in United States and Possessions, Canada, and all countries in the American Postal Union, \$2.50 per year, postpaid. Single copies, 25 cents. Foreign countries not in American Postal Union, \$3.00 per year, postpaid. Remittances should be by international postal or express money order or bank draft negotiable in the U. S. and for an equivalent amount in U. S. funds.

Entered as second-class matter May 29, 1919, at the post office at Hartford, Connecticut, under the act of March 3, 1879. Acceptance for mailing at special rate of postage provided for in section 1103, Act of October 3, 1917, authorized September 8, 1922. Additional entry as second-class matter, acceptable at special rate of postage provided for above, at Springfield, Mass., authorized September 17, 1924.

Copyright 1926 by the American Radio Relay League, Inc., Title registered at United States Patent Office.  
Member of the Radio Magazine Publishers' Association.

# THE AMERICAN RADIO RELAY LEAGUE

The American Radio Relay League, Inc., is a non-commercial association of radio amateurs, bonded for the promotion of interest in amateur radio communication and experimentation, for the relaying of messages by radio, for the advancement of the radio art and of the public welfare, for the representation of the radio amateur in legislative matters, and for the maintenance of fraternalism and a high standard of conduct.

It is an incorporated association without capital stock, chartered under the laws of Connecticut. Its affairs are governed by a Board of Directors, elected every two years by the general membership. The officers are elected or appointed by the Directors. The League is non-commercial and no one commercially engaged in the manufacture, sale or rental of radio apparatus is eligible to membership on its Board.

"Of, by and for the amateur", it numbers within its ranks practically every worth-while amateur in the world and has a history of glorious achievement as the standard-bearer in amateur affairs.

Inquiries regarding membership are solicited. A bona fide interest in amateur radio is the only essential qualification; ownership of a transmitting station and knowledge of the code are not prerequisite. Correspondence should be addressed to the Secretary.

## OFFICERS

*President*  
**HIRAM PERCY MAXIM**  
Hartford, Conn.

*Vice-President*  
**CHAS. H. STEWART**  
St. David's, Pa.

*Communications Manager*  
**F. E. HANDY**  
Hartford, Conn.

*Treasurer*  
**A. A. HEBERT**  
Hartford, Conn.

*Secretary*  
**K. B. WARNER**  
Hartford, Conn.

## DIRECTORS

*President*  
**HIRAM PERCY MAXIM**  
Drawer 4,  
Hartford, Conn.

*Vice-President*  
**CHAS. H. STEWART**  
St. David's Pa.

*Canadian General Manager*  
**A. H. K. RUSSELL**  
6 Mail Bldg.,  
Toronto, Ont.

*Atlantic Division*  
**DR. EUGENE C. WOODRUFF**  
234 W. Fairmount Ave.,  
State College, Pa.

*Central Division*  
**CLYDE E. DARR**  
137 Hill Ave., Highland Park,  
Detroit, Mich.

*Dakota Division*  
**C. M. JANSKY, JR.**  
Dept. of Elec. Eng., U. of M.,  
Minneapolis, Minn.

*Delta Division*  
**BENJ. F. PAINTER**  
424 Hamilton Nat'l Bank Bldg.,  
Chattanooga, Tenn.

*Hudson Division*  
**DR. LAWRENCE J. DUNN**  
480 East 19th St.,  
Brooklyn, N. Y.

*Midwest Division*  
**PORTER H. QUINBY**  
Box 184A, Route 6,  
Omaha, Neb.

*New England Division*  
**DR. ELLIOTT A. WHITE**  
Dartmouth College  
Hanover, N. H.

*Northwestern Division*  
**K. W. WEINGARTEN**  
3219 No. 24th St.,  
Tacoma, Wash.

*Pacific Division*  
**ALLEN H. BABCOCK**  
65 Market St.,  
San Francisco

*Roanoke Division*  
**W. TREDWAY GRAVELY**  
503 Main St.,  
Danville, Va.

*Rocky Mountain Division*  
**PAUL M. SEGAL**  
c/o District Attorney,  
West Side Court Bldg.,  
Denver, Colo.

*Southeastern Division*  
**HARRY F. DOBBS**  
c/o Dobbs & Wey Co.,  
Atlanta, Ga.

*West Gulf Division*  
**FRANK M. CORLETT**  
2515 Catherine St.,  
Dallas, Tex.

Address General Correspondence to Executive Headquarters, Hartford, Conn



# EDITORIALS

## We Advance

**A** GOOD many signs are indicating that radio in this country is in a flourishing condition and "all set" to experience a profound increase in the number of its devotees and in its prestige. A huge number of new-comers is seeking information on amateur transmission and endeavoring to find out how to enter the game. For several months our Information Service has been blowing fuses and tripping circuit breakers regularly under an overload of inquiries of this sort. At the Hudson Division Convention two hundred neophytes knowing nothing practical about amateur work but possessed of a burning desire to learn, attended the three-day course and eagerly drank up information on "breaking in". We talked to dozens of them who are now engaged in mastering the code and firmly resolved to build stations and become transmitters. They are fine people; they are valuable recruits to our ranks.

Something has happened to broadcasting. The dial-twisting portion of the BCL ranks has slumped into complacent acceptance of its present apparatus. The experimenter class, the BCL with the active mind is turning to amateur radio. The result is reflected in what is happening to the industry and to the advertising columns of most of the radio magazines. Last month *QST* had more pages of paid advertising than any other radio magazine in America. Our advertisers say that *QST* produces results for them, fine results. In other words, the transmitting amateurs are the active people in radio in this country today. And have you noticed the changed complexion of the "ads"—products brought out especially for the amateur, and advertisements directed specifically at us amateurs? It looks like old times.

The reason for these things is not hard to find. Mere listening-in palls. We amateurs have a patent on the most interesting form of radio in the world—two-way communication. To our followers we offer friendships, world-wide DX, engineering experience, and a broader knowledge of the

world in which we live. It is something on an altogether grander scale than one-way listening. We are doing something to advance the world. Consider in this thought a recent comment by our president, Hiram Percy Maxim:

"With international communication a matter of nightly occurrence, amateur radio stands to-day as one of the most powerful forces working for world peace. In this connection there is no more significant statement than that recently made by one of our members, a retired army officer. 'Do you think', he said, 'that any politician can stampede me into declaring war on my friends in other countries—friends with whom I hold nightly communication? Never!'

"As the telephone, the railroad and the automobile have brought about national understanding that to-day makes another civil war a virtual impossibility in these United States, so private two-way telegraphic communication is to-day quietly working toward world peace by bringing about international understanding and fellowship."

Let us carry on!

## "It Won't Be Long Now"

**T**HE business of off-wave amateur operation has become very serious, particularly the interference caused naval communications in the region immediately below our 37.5-42.8-meter band. *QST* has carried an unconscionable number of articles and warnings on the subject. The situation is still as bad as ever. The League cannot afford to permit the rights and privileges of the majority of its members to be jeopardized by the unlawful actions of a few who will not be decent enough to comply with the regulations. This is a final warning to the recalcitrant and the slipshod. Get where you belong, for the Wouff-Hong is being unshipped and tuned for action!

—K. B. W.

# Feeding the Antenna

By Robert S. Kruse, Technical Editor

**A**BOVE all things, this paper must be brief, and as there is much territory to cover I shall have to make some positive statements that may not suit the mathematician. Please remember then that these remarks are supposed to give operating information—not to state exact scientific fact.

## The Kinds of Antennas

Very few amateur stations operate with ground connections these days. When a ground connection is used the feed problem is dead simple—just couple to a coil near the ground. With that we will drop the grounded antenna and talk about the ungrounded variety—the sort that operates with a counterpoise.

For the sake of simplicity let us say that the grounded antennas are of the Marconi type and the antenna-counterpoise systems are of the Hertzian type. Referring to Figure 1, forms 1 and 2 are undoubtedly of the kind devised by Prof. Hertz. (Incidentally, his name is pronounced with a short e as in "met" or "bet"). There is a little

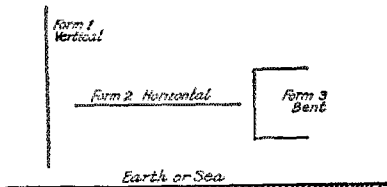

FIG 1—HERTZ ANTENNAS

room for argument about form 3 but most amateur counterpoises are small and fairly well off the ground so it is fair to say that in practice this form also operates as a Hertz antenna.

Things are now simplified greatly. We can talk about the ways of feeding a straight antenna like form 1 or form 2 with the understanding that the schemes shown will also work for the more common bent Hertz antenna of form 3. Just one caution—think twice before deciding where the voltages are on a bent antenna system; then check up on yourself by some simple method such as trying for sparks with a screwdriver blade—and it might be just as well to use a screwdriver in which the blade does not come thru the wooden handle.

## Radiation

On second thought another caution must be added. It is true that forms 1, 2 and 3 can be fed in the same manner but that does

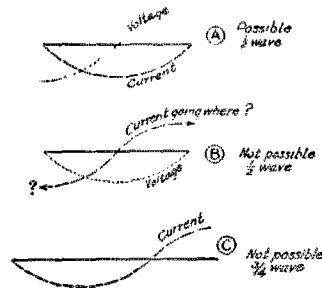

FIG. 2 VOLTAGES AND CURRENTS

not mean that they radiate in the same manner. The energy can be put into all of them in the same ways but it gets out (radiates) in decidedly different ways. To explain these differences would drag us into a long argument as to polarized waves, skip distances, and high angle radiation—and we don't have time for that. Let us stick to the problem of getting the power into the antenna, leaving each station owner to decide on the antenna best suited to his distance, time, wavelength and location.

## The Nodal Points

Because the cuts fit so nicely into a QST column we will make all our diagrams to fit the form 2 (horizontal Hertz) antenna, remembering that the same feeding methods will fit forms 1 and 3 of Figure 1. It is quite likely that forms 1 or 3 will fit your job better but let's leave that out—we are talking about feed methods and if we get them straight for antennas of form 2 it will be easy to fit them to forms 1 and 3.

First of all, let us get one thing clearly in mind. On any Hertzian antenna we will have  $\frac{1}{2}$ ,  $\frac{2}{2}$ ,  $\frac{3}{2}$ ,  $\frac{4}{2}$  etc. wavelengths—but always a number of half-waves. We cannot have a  $\frac{1}{4}$  wave or  $\frac{3}{4}$  wave as we could with a Marconi antenna. This means that the Hertz antenna will always have voltage at the end of the antenna and voltage at the end of the counterpoise. We can't possibly have current at these ends because a current has to have something to flow into—and there isn't anything—the wire stops. If

you want to look at it that way the electricity rushes to the end of the wire and piles up there as a static charge—a voltage.

Figure 2 attempts to show this. The thing shown in A of Fig. 2 can, and does happen. Here we have a current at the center of the antenna—and as we go to the ends of the antenna there is less and less current—but more and more voltage. The thing shown in B of Fig 2 doesn't happen because the current can't be at the ends of the antenna—it has to flow into something as we said before. In the same way combination C can't happen. The part to the left is alright but the part at the right is all wrong. Is that clear? Very well. Let's go on to the real subject—the feed methods.

**Voltage Feeds and Current Feeds**

There seem to be two main varieties of antenna feeding schemes, those that feed the antenna a fairly large current at low voltage (current feed systems) and those that feed the antenna a very small current at a fairly good voltage (voltage feed systems). Naturally a current feed system must connect to the antenna at a place where it is possible to have current while a voltage feed system must connect at a place where it is possible to have voltage.

Referring to Fig. 3A, we have a current feed system that every reader of QST has used. Certainly 90% of all amateur stations work with this arrangement. Here the antenna has had a gap cut at its center (X) and to the two sides of this gap is connected the current-feeding device which consists of a secondary coil S and a pair of

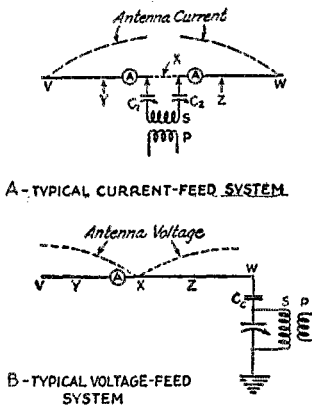
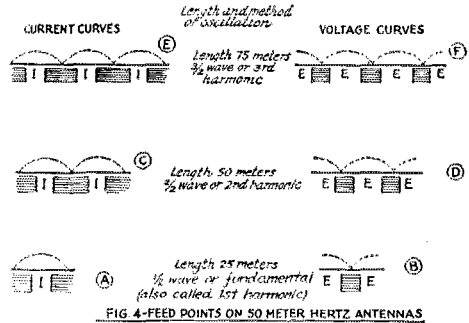

FIG. 3 TYPICAL FEED SYSTEMS

series condensers. Current is induced in S by the primary P and this current is fed into the antenna thru the series condensers C1 and C2. If one feels like it C1 and C2 can be removed. Their

business is to keep S from loading the antenna to a higher wavelength. Now then—this feeder arrangement could have been cut in at Y or at Z, altho X is the best place for it. It would not work well if it were cut in at V or W because there isn't any current at those places. The thing may seem to work



but one soon finds that one of the series condensers doesn't tune as it should—also other unpleasant things happen. Note one thing especially about the current feed system—it is connected to the antenna at two points.

**Voltage Feed**

In Fig. 3B we have one sort of voltage-feed system. Here the tuned secondary circuit is connected to a voltage-point on the antenna such as V or W. It would work also at Y or Z but not at X. In the current feed system we had the biggest antenna current right at the feeding point—that is to say right next to the condensers C1 and C2. With the voltage feed system there is very little current at the coupling condenser Cc (Fig. 3B) so we must put the antenna ammeter a ways out as shown in 3B.

Note that the voltage-feed system connects to the antenna at one point only. The other end of the tuned secondary S may be grounded or not. More of that later.

**Harmonic Operation**

Now we have two different ways of feeding—and to complicate things there are several possible ways to operate the antenna—fundamental, second or third harmonic. Where are we to hitch on the feeders—and where does the antenna ammeter go?

It isn't really so mixed up as one would think. A little study of Figure 4 will clear the thing up pretty well.

The set of curves to the left shows the way the current is located in a variety of 50-meter antennas—I mean antennas operating at 50 meters. The shaded places are no good for connecting a current-feed system while the white places marked "I" are O. K. for this purpose. The places marked I

are also the correct ones at which to cut in the antenna ammeter.

In the right-hand set of curves we see how the voltage is located in the same three antennas. The shaded places are no good for connecting on a voltage-feed system, (these are the same places marked "I" in

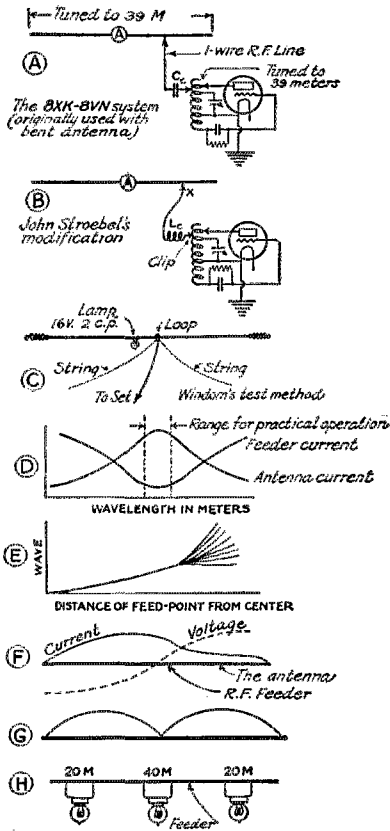

FIG. 5 HINTS ON VOLTAGE FEED

the other set of sketches) The places marked "E" are the ones at which a voltage-feed system can be connected.

If these sketches are not clear try comparing them with Fig. 3, noting that 3A and 4A are the same thing, also that 3B and 4B are the same

**Voltage Feed Advantages and Disadvantages**

The first voltage-feed system to become well known in the amateur game was that shown in Fig. 5A. It will be recognized as the 8XK-8VN-KDKA scheme. Its advantage is supposed to be that it keeps the entire antenna system outdoors. In the hands of a careful operator this system is capable of nice work.—I don't know anything in radio that gets into trouble more easily, because there are so many ways of adjusting the coupling, because the R. F.

line delights in radiating and because the harmonics of the primary circuit transfer themselves to the antenna circuit with discouraging strength, in many sets using this system of connections.

John Stroebel, of the famous old 8ZW, did a great deal of work with this system of antenna feeding and has passed to us some of the methods used to cure the above difficulties. Some of them remind me of the Columbus-and-his-egg story, any simpleton can see that the method is correct—after the "columbus" of 8ZW has pointed it out.

First of all—the harmonic difficulty. It is easy enough to see that the harmonics will get thru the little condenser Cc of Fig. 5A more easily than the fundamental, for the very good reason that high frequencies always get thru a condenser more easily. Measurements at 1HX-10A-1XAQ showed that it was perfectly possible with this scheme to make the 3rd harmonic more than twice as strong (as compared to the fundamental) in the antenna as in the primary—while with ordinary inductive coupling the reverse was true. What to do? What to do? Stroebel points out that if the negative reactance of the condenser Cc does the reverse of what you want we ought to be able to get out of trouble by using the opposite sort of a reactance—in other words to use an inductance as at Lc in Fig. 5B. This was tried—and worked perfectly. It is in A1 operation at a number of amateur and broadcast stations and a few commercial ship-to-shore stations. This same scheme, used in the same set 1HX-10A-1XAQ showed harmonics at least as weak as those gotten with ordinary inductive coupling.

Stroebel also recommends keeping the R. F. line as low down as possible to keep it from wanting to be part of the antenna system. If the current in the line gets to be more than about 10% of the current in the antenna there is a strong chance that the line is radiating too. This may mean that there is radiation at two waves—and one of them is likely to be in someone else's wave band.

Where the R. F. line is a long one there is a fair chance that standing waves will develop along it. This isn't supposed to happen. If you find that a neon tube touched to the R. F. line glows strongly at some points there is something wrong—better cut down the size of Cc—or increase the size of Lc—or put another one of the things into the line at the antenna end, at the place marked "X" in Fig. 5B.

Stroebel says that for 80-meter work Lc may have 20 turns of No. 14 wire wound on a 4½" form with ½" spacing on centers of turns. The coil should have one fixed connection and one clip connection. When too many turns are used the antenna current goes down and the primary current goes up.

When too few turns are used the system becomes unsteady, radiates another wave way off the original one, and so on.

The position of the marked clip in Fig. 5B also varies the antenna input. When it is at the filament connection there is no input to the antenna, and as it is raised the input increases. Finally the system becomes unsteady as before.

Still another way to change the coupling is by shifting the tap along the antenna. L. G. Windom of 8GZ has investigated the action of this adjustment. His work is reported herewith in his own words—

### Adjusting the Voltage-Feed System

By L. G. Windom, 8GZ and 8ZG

“An antenna without a driver is worthless—so we might as well drop the whole discussion unless all hands are willing to agree that we need some sort of a driver. The primary circuit that you like best will work best for you. That’s that. Now for the antenna.

“The antenna is a single straight wire with a fundamental of 2L plus—Gawd knows what. To get the right antenna length we make a good guess and cut the wire to a length equal to  $\frac{1}{2}$  the length of the wave we desire to work at. Everything—everything—changes the wavelength so this can’t be more than a guess. Hang only a small length of wire on one end of the system and you throw the normal voltage distribution way off. For practical purposes the best way to get the antenna into action is to cut the wire as suggested and then tap the feeder somewhere near the center—with the feeder arranged to be moved back and forth as shown in Fig. 7C. The antenna current indicator may be a meter but a 16-volt, 2-c. p. lamp is fine—because of its ease of reading! The light should be shunted around about six inches of the antenna for a 250-watter, 12 inches for a 50 and about 1 yard for a 5-watter.

“Tap the feed wire directly off the transmitting inductance, about 1 turn above the filament tap on the helix. This may have to

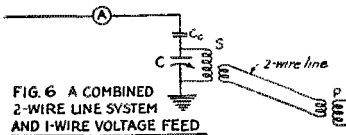

FIG. 6 A COMBINED 2-WIRE LINE SYSTEM AND 1-WIRE VOLTAGE FEED

be changed later but will work well enough until adjustments can be made. Now give her the juice and tune the transmitter for maximum brilliancy on the lamp. Read the wavelength with a GOOD wavemeter. It will probably be way too high-up, around 45 meters. Now start with the feeder about a foot from the center of the antenna and tune the primary until you get the best antenna (not feeder) current that can be gotten with this combination. Now repeat

with the feeder about two feet from the center of the antenna. Continue this and each time put down the (A) antenna current, (B) feeder current and (C) wavelength. There will be one position of the feeder which will give the largest antenna current and very nearly the smallest feeder current. If all the A, B and C readings are plotted we will have a curve like that of Fig. 5D. It is evident that there is one wavelength at which the system works best

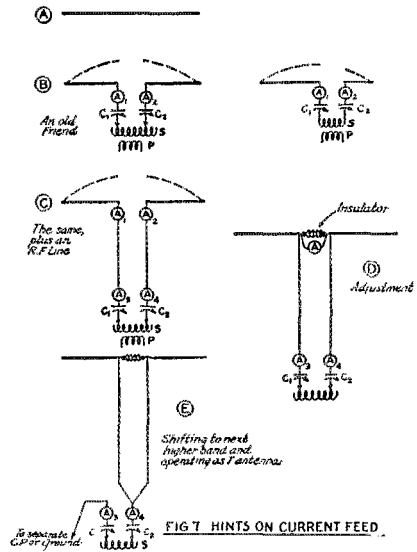

FIG. 7 HINTS ON CURRENT FEED.

—also that the position of the feeder affects the fundamental of the system greatly. (It has less effect when the choke—or chokes Lc are used.—Tech. Ed.) The chances are that this “best wave” is too high. Take off a small (equal) amount from each end of the antenna—somewhat less than  $\frac{1}{2}$  the desired drop. Now repeat the process, starting again with the feeder near the center of the antenna. By this method we will finally arrive at the proper antenna length and feeder position. The wave can be varied over about a 2-meter band around the fundamental while still obtaining good antenna current. The points of highest antenna current and lowest feeder current are not exactly the same—split the difference.

“Another effect of moving the feeder away from the center of the antenna is to cause the wave to become broader as well as higher. Figure 5E attempts to illustrate this. Beyond a certain point local interference goes up rapidly and BCL troubles begin.

“Now take the ground off the filament—if it still works in the same manner it is O.K.—if it changes you have nothing but a poor antenna-ground system with direct coupling

—which is all wrong. However I'll guarantee it to work O. K. if these directions are followed.

"Another effect of the feeder seems to be somewhat as shown in Fig. 5F—that is, the feeder distorts the voltage and current distribution as shown.

### Harmonic Operation

"At 20 meters the current curve would look as per Figure 5G. (This is the same as Fig. 4C and 4D. Here we see that to work at 20 we need a second antenna-current indicator placed at the quarter length—half way between the center and one end. One each side of the center as in Fig. 5H, helps to determine the proper wave more easily but at any rate it is *not* exactly half of the "40-meter" one but will be somewhat higher. Here again we must remove the filament ground to see if we really have a Hertz antenna. If we have, the ground has no effect—except to protect the filament transformer.

"So far we have neglected the possibility that the feeder may accidentally get into the argument by being on the fundamental or a harmonic. If this happens we must

to radiate somewhat and that the line can't be made very long without a good deal of trouble. Still—the system does let one hoist the antenna out of the road of things—or put it into the next yard.

A combination that does all of these things—and a few more—is shown in Fig. 6. It will be recognized as the circuit used at 2XAF. The 2-wire R. F. line may be tuned or untuned—the latter preferable—and in any case radiates very little as the two wires cancel each other's effect. This sort of a line can be run near buildings etc. without as much loss as was caused by the 1-wire line. The 1-wire portion of the system can now be made short—avoiding the various unpleasant effects on the antenna system to some degree. This scheme of course has the great drawback that a change of wavelength requires one to gallop out to the antenna to tune the feed-circuit at the bottom of the 1-wire line. What of that? It isn't any worse that the arrangement of Fig. 5 which *can't* be made to QSY except over a very small band indeed.

All of these things can be avoided by the use of 2-wire lines in another way, and for that way we must go back to current-feed systems.

### The Current Feed Systems

In Figure 7A we have—let us say—the same antenna that Windom spoke of. It has a fundamental of 40 meters. In 7B we have cut a gap out of it and into this gap have placed a feed combination consisting of an R. F. transformer secondary and a pair of series condensers. The R. F. secondary S loads the antenna to—perhaps—50 meters and the condensers counteract this effect.

Certainly every single reader of QST has used this circuit, though generally with a bent antenna such as we have called form 3. If he happened to be at the center of the antenna system as in B (left) the currents in the two meters were about the same, if he was off the center (above or below) as in 7B (right) he found that the currents were not the same—and wasted a lot of time fooling with clips and condenser settings until he had made them equal—after which the system did not work as well.

Also—all of you know—the settings of the condensers C1 and C2 can be used to make the antenna work from about 2/3 of its fundamental wavelength on up—a big advantage over the voltage-feed systems we have spoken of. However, to get that advantage we have had to bring the center of the antenna system into the station and that spoils things altogether for some locations, or for the chap who wants a straight Hertz antenna, either horizontal or vertical.

### A Suggestion by Dr. Alexanderson

A practical way to combine a tunable antenna with current feed and a 2-wire R. F.

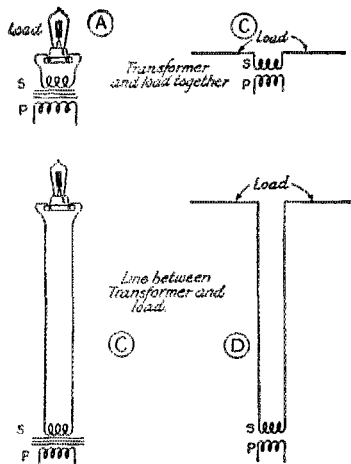

FIG. 8

insert a condenser—or a small inductance—in the feeder to detune it.

"After these adjustments are made the feeder works at an excellent power factor. Here at 8ZG-8GZ the feeder current is 4/10 of an ampere with an antenna current of 12 amperes."

### 2-wire R. F. Lines

From the above it can be seen that the system requires some careful work, the 8GZ-8ZG is a station proving that it may be worth while. The drawback of the system is that the antenna circuit can't be tuned from the station, that the 1-wire line tends

line that will not radiate was suggested by Dr. E. F. W. Alexanderson—and tried by the writer within 24 hours. It has worked out very well indeed and is very simple to get into operation. In Fig. 7B we have the R. F. transformer right at the load. Why is that necessary? Look at Fig. 8A for a moment. Here we have a lamp right at the secondary of the 60-cycle transformer. Will the lamp keep on burning if we take it off at the end of the line as in 8B? Of course it will unless the line has excessive resistance or is in tune with the A.C. supply—which seldom happens at 60 cycles.

Now look at Fig. 8C. Here we have an

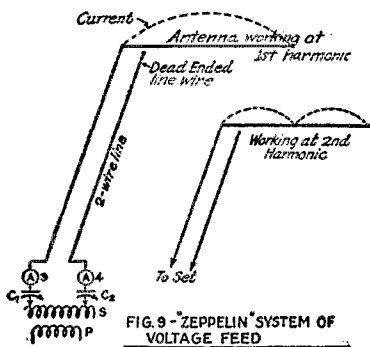

R. F. transformer with the load (which is an antenna instead of a lamp) right at the secondary terminals. Will the antenna keep on drawing current if we put it off at the end of a line as in 8D? "Of course it will unless the line has excessive resistance or is in tune with the A. C. supply"—which can happen at 7,500 k. c.

Now let's go back to Figure 7B. and separate the antenna from the transformer just as we did in Fig. 8. This gives us the arrangement of 7C which permits the antenna to be put almost anywhere while the thing can still be tuned from the station as before. When operating on the antenna fundamental we have the current distribution shown in 7C, if we tune a bit higher we will move the maximum current back into the line a bit so that part of the line gets into the antenna system and loads it up. Thus we need only to make the antenna of the right length for the lower edge of the 40-meter band—and then can work anywhere in that band by tuning the secondary circuit as we always have—but the antenna can be where we want it.

**Adjustment and Wave Shifts**

To put the system into operation is about a 1-hour job at the most. One connects a meter across the end of the R. F. line as shown in Fig. 7D and tunes the primary and secondary to different waves until one finds out the wave which gives the biggest current thru this meter. This wave length

will be nearly twice the length of the wire (in meters of course), altho not exactly. Now change the length of the antenna wire (not the line) until the best current is gotten when tuned just a little above the lower edge of the "40-meter band." The meter can then be taken out of the antenna, after this we can use the meters A3 and A4 at the station end of the line—better leave both of them in the circuit. To shift higher up in the 40-meter band tune the primary circuit to the desired wave and then resonate with condensers C1 and C2, keeping their settings about the same and keeping the readings of A3 and A4 about the same. That's all there is to it—dead easy.

Now we can use to a difficulty. This antenna we have works O. K. in the 40-meter band, but what do we do about the 80-meter band? If the antenna happens to be a horizontal one—or nearly so—we are still alright. We can then switch over to the arrangement shown in 7E, use another c. p. or ground and operate the thing as an ordinary T antenna that happens to have a double downlead.

**The "Zeppelin" Type of Antenna**

Dr. Pickard has previously called attention to one sort of voltage-feed system that s not getting the attention it deserves. This is the arrangement shown in Fig. 9, which almost explains itself. With this scheme there is no tuning equipment out in the back yard, the line is non-radiating and the construction is dead simple in all ways. The affair can be made to oscillate with 1/2, 2/2 or 3/2 waves on the extended end, therefore will work in the 20-, 40- and 80-meter band. It has worked very well at 10A-1BA0.

**Concerning Construction**

The construction of these R. F. lines seems to worry amateurs very much—which isn't necessary at all. The currents in the

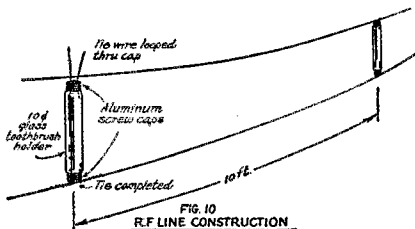

R. F. lines are small compared to the antenna currents so the line wire may be as small as will give the needed strength. In the voltage-feed systems (except the one suggested by Dr. Pickard) there are fair voltages on the line and its insulation must be thought of—also the losses if it gets near anything. In the 2-wire R. F. lines these things are not nearly as important—also we can stand a surprising amount of

swinging without much effect on the wavelength. The spacing between the two wires of the R. F. line can be done in a number of ways. Ordinary antenna insulators are a bit heavy and not quite long enough. I have used glass rods with tie wires cemented to their ends with hot battery compound. This is a messy sort of proceeding and a very neat dodge was suggested by my wife. The scheme is explained in Fig. 10. The toothbrush holders can be bought at Woolworths—at least they can be at Springfield, Mass. and in that store on 5th Avenue in New York City. There is a special delight in buying 10c toothbrush holders on 5th avenue. That alone ought to be enough to make some of you try this 2-wire line business.

## High Power Transmitting Condensers

FOR use in high power amateur transmitting stations, in broadcasting stations, in commercial s/w outfits and in the laboratory where super-accurate condensers that will stay-put for many years are required, two types of over size condensers are available. Unfortunately the beauty of construction of either type is utterly lost in a photograph. It is even difficult to get some idea of the proportions of the condensers from mere pictures of them.

The husky brute alongside the 201 tube is

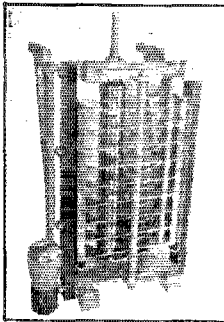

one of a series manufactured by Allen D. Cardwell. This particular one has a maximum capacity of 141  $\mu\text{fd.}$  and a minimum around 30  $\mu\text{fd.}$  The spacing between centers of the plates is one half inch. Hard rubber insulation is used throughout. The hard rubber strips are twelve inches long with a cross

section of one half by one inch. The generous insulation is used to prevent excessive mechanical strain on the rubber. Despite all this insulation the actual contact area between hard rubber and stator is less than a square inch. The rotor shaft is fourteen inches long and one and one half inches in diameter. The rotor plates are soldered into slots machined in the shaft. The panel-end bearing is of monel metal, and at the rear end is the familiar steel ball-bearing as found in the small Cardwell receiving condensers. Stator plates are soldered into large brass supporting rods.

A corona shield is fitted over the supporting rods, the ends of the shield being curved. All corners and edges are carefully rounded. Practically all of the metal in the condenser is highly polished brass. The breakdown voltage is around 10,000 at 20 meters.

The other photograph shows the large size National condenser alongside one of their large amateur transmitting variables. The big baby is made in two types, with balanced

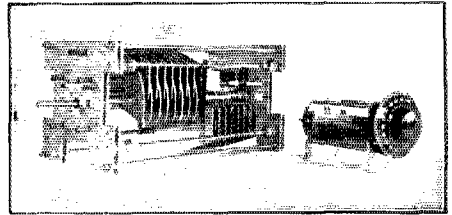

and unbalanced rotor plates. The maximum capacity of each is the same—500  $\mu\text{fd.}$  The minimum capacity of the balanced type is 90  $\mu\text{fd.}$  and of the unbalanced type 50  $\mu\text{fd.}$  The condenser plate material is aluminum. The shaft is made of bronze and the bearings are annular ball type. The rotor and stator spaces are nickel plated brass. Eight Pyrex pillars, four at each end of the stator assembly, are used for insulation. The end plates are pulled toward each other by the four heavy tie-rods, one in each corner, and are kept apart by the stator assembly and the Pyrex insulation. Contact between rotor and end plate is had by means of a bronze spring. This condenser was designed primarily for use in a 500-watt transmitter operating around 40 meters. It has found considerable application in the broadcasting field, however. The job is so nicely balanced that the rotor can be spun around with a very slight twist of the shaft. The breakdown voltage is around 10,000 at 60 cycles.

Both of these condenser jobs are excellent. The workmanship is typical of the two concerns who make them, and their uses are such that they fit nicely whenever and wherever a precision type of high voltage condenser is needed. Due to the most generous spacing between plates they should make excellent precision condensers of the secondary standard type.

—J. M. C.

Strays

SLO sez that ordinary No. 6 dry cell cartons make excellent low loss coil forms. A small piece of Bakelite in the end and G-R plugs for mounting complete the job.



# Quartz Crystal Mountings

By John M. Clayton, Assistant Technical Editor

**T**WO types of quartz crystal mountings are in use today. For precision work, where it is necessary for the frequency to remain constant, with a very high degree of accuracy from day to day, it is customary to mount the crystals between two ground plates mounted with a small air gap between the crystal and one plate. This air gap, with the ordinary size and shape of crystal, is usually only several tenths of a millimeter.

This precision type of mounting is typified by the General Radio mounting, an illustration of which is shown in Fig. 1. A sketch of the "internal works" of the G-R mounting is shown in Fig. 2. The bottom plate A is bolted to the bakelite base by

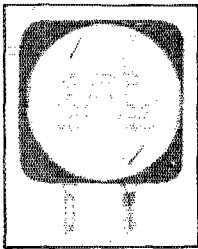

FIG. 1. THE GENERAL RADIO MOUNTING

means of a countersunk machine screw. A lead connects this screw, and plate A, to one of the contact plugs P. The crystal C (in this case a round one) rests in a cupped-out part of A, the top surface of the crystal extending quite a distance above plate A. Over the bottom plate and the crystal a brass "cap" B is placed. This plate is attached to the base by means of the two machine screws shown in Fig. 1. It is also connected to the second contact plug. The top surface of A and the inside surface of B are ground as parallel as possible. The air gap between the crystal and the B plate is about 0.2 or 0.3 millimeter. The construction of a mounting of this type is strictly a machine turning job.

The Bureau of Standards type of precision mounting is shown in sketch form in Fig. 3. In this case the base is also used as a housing for the crystal. The base is made of a piece of bakelite  $\frac{3}{4} \times 2\frac{5}{8} \times 2\frac{7}{16}$  inches. The brass bottom plate A has a diameter slightly greater than that of the crystal. The bakelite base is turned out on a lathe so that this plate A will fit snugly in the bored out portion of the bakelite. While the bakelite is in position in the

lathe, the top surface is turned down so that it will be parallel with the bottom of the "cup." The crystal C rests on the top

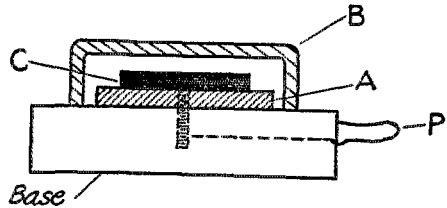

FIG. 2. INSIDE THE G-R MOUNTING.

of plate A, and over the crystal another brass plate B is bolted. This plate is square and should be at least 1/16 inch thick. The depth of the cup in the bakelite should be such that when the plate A is bolted in place (by means of a countersunk machine screw) and the crystal is placed in the cup, there being an air gap of about 0.3 mm between the crystal and the top plate. Two G-R plugs are threaded into the end of the base and contact is made to the machine screw holding A in place, and to one of the bolts extending through plate C and the base. The plate A must be ground on one surface, and both of its surfaces must be parallel. The Bureau specifies that the brass plates should have a dull nickel finish.

A type of mounting which does not require the services of a machinist, plus a lathe, is shown in Fig. 4. This construction is due to J. E. Hodge of 4BY. The plate

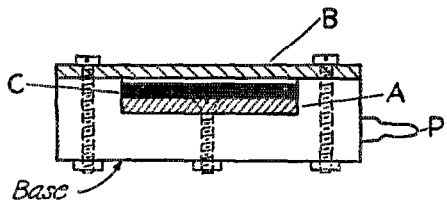

FIG. 3. THE TYPE USED AT THE BUREAU OF STANDARDS

A is of  $\frac{1}{8}$  inch brass, with one surface ground flat. On top of this plate a hard rubber frame B rests. The cut-out portion of the hard rubber is a little larger than the crystal itself, and the frame is a trifle

thicker than the crystal. The surfaces of the frame must be parallel.

On top of B another brass plate C  $\frac{1}{8}$  inch thick, and having the same shape as B, is placed. Both B and C should be small enough to rest on A in such a manner that

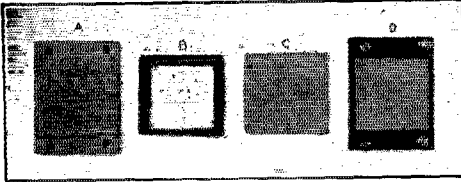

FIG. 4. AN EXPLODED VIEW OF AN EXCELLENT MOUNTING BY 4BY

they will be at least an eighth of an inch from the holes in the corner of A. And lastly a hard rubber plate D is made the same size as A. The hard rubber piece is also  $\frac{1}{8}$  inch thick. To the top of the hard rubber piece, Hodge has also attached a thin piece of brass material, held in place by four pins which go through the hard rubber and make contact with C when the mounting is assembled. This was done so that the mounting could be slipped into a mounting of the spring compression type. The last piece of brass can be omitted and a flexible lead can be soldered to the plate C, or G-R plugs can be fitted to both A and C. In the corners of plates A and D four holes are drilled. The holes in A are tapped for a 6-32 machine screw. When assem-

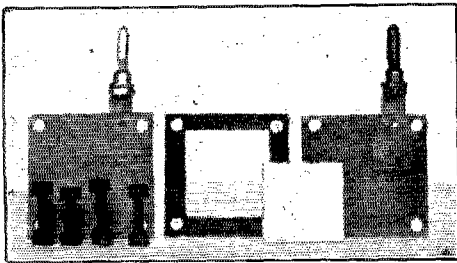

FIG. 5. ANOTHER SIMPLE MOUNTING BY STAMPS AND LIBBURY

bled, plate B rests on A, the crystal is inside of B, and C and D are on top of B. The whole mounting is clamped tightly together by the four screws in the corners.

F. A. Stamps and Austin Libbury are responsible for the mounting shown in Fig. 5. It is similar to the Hodge type with a few exceptions. The hard rubber frame-plate is the same size as the two brass end-plates.

The assembly is held together by means of four hard rubber bolts made by turning up a piece of hard rubber rod and threading it. To the outside of each brass cover a General Radio plug is attached by means of a small brass angle. The hard rubber bolts are used to insulate the plates and at the same time prevent the plates from being compressed too tightly. We see no reason why a bakelite frame could not be used in both this and the Hodge type. There is no danger of the bakelite "flowing" out of shape and altering the thickness of the air gap. In precision work the varying air gap would make some slight change in the frequency of the crystal. Bakelite would make a mechanically stronger job, also.

In all of the above mountings where plugs are used it is desirable, of course, to center the plugs so that the crystals can be used interchangeably. The usual centering distance is  $\frac{1}{4}$  inch. In all cases it is absolutely necessary that the surfaces coming in contact with the crystal be absolutely flat and parallel.

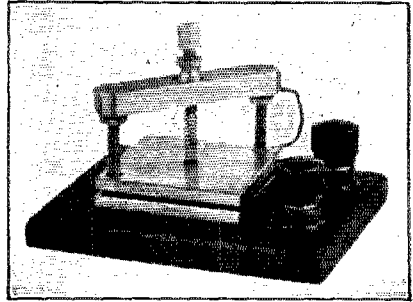

FIG. 6. TRANSMITTER TYPE DUE TO HAROLD WESTMAN

The second class of mounting is that used in high power oscillator and transmitter work. The simplest mounting for this class of work consists of two brass plates (again the  $\frac{1}{8}$  thickness is OK) having their surfaces ground flat. The crystal is placed between the two and the top plate is allowed to rest on the crystal. Connections are taken off from the top and bottom plates by means of flexible wire soldered to the plates.

A mounting made by Harold Westman of the Information Service is shown in Fig. 6. This mounting was described in detail on page 24 of the January 1926 issue of QST. The top plate is not relied upon solely to furnish pressure to the crystal. A light spring is arranged to push the plate down with slight pressure on the crystal.

In all cases the plates can be ground in the same manner as the crystals themselves. Instructions for grinding will be found on page 9 of the November 1925 issue of QST.

## More Arctic Adventure

Manley Sails With VOQ, the "Morrissey;" MacMillan Going Again;  
Wilkins Expedition Hangs On

**B**Y the time these lines are in print another American expedition will be on its way to the Arctic, and again it will be equipped with short-wave radio and placing its dependence for communication upon contact with American amateurs. This is the American Museum Greenland Expedition, sailing about middle June for the vicinity of Etah to collect material for the American Museum of Natural History in New York, financed by the museum and George Palmer Putnam, of G. P. Putnam's Sons, publishers. The party sails in the Newfoundland fisherman "Morrissey," which has been refitted for the purpose, under the direction of Mr. Putnam and in command of Captain "Bob" Bartlett, who was master of Peary's "Roosevelt." Again the radio operator is a well-known League member, Edward Manley, of 8FJ, Marietta, Ohio. The party expects to be out about four months, returning in the fall.

The transmitter was built by Manley,

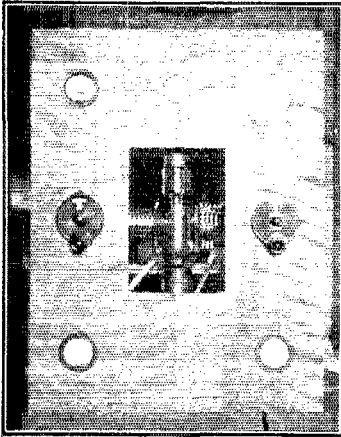

THE TRANSMITTER OF VOQ, BUILT BY EDWARD MANLEY OF 8FJ, WHO WILL BE THE OPERATOR ON THE "MORRISSEY"

and uses one UV-204-A tube on D. C., operating on 20 and 33 meters. Esco motor-generators giving 2000 volts and 12 volts are operated by a large storage battery, which in turn is charged by a generator driven by an auxiliary engine. The receiver, a short-wave plug-in autodyne with two stages of audio, was built by the C-W Laboratory of Hartford. A 1000-volt battery of Eveready 45-v. "B" units is carried for tests and emergency transmitter use,

The call of the "Morrissey," which is under Newfoundland registry, is VOQ. Manley will have the usual variety of personal messages and miscellaneous traffic which he will desire to handle by amateur radio. Stations receiving such traffic are requested to forward it to destination by radio and to confirm by mail. We understand that Atwater-Kent and National Carbon Co. are supplying funds for the radio installation, and these companies offer an Arctic trophy to the station handling the most traffic of this sort. Part of the traffic, news stories presumably, will be coded into brief form and handled on schedule with the most reliable stations available, and these messages should be forwarded by stations accepting them to G. P. Putnam's Sons, 2 West 45th St., New York, by telegraph at press rates collect. Let us see what we can do for Manley!

### The Wilkins Expedition

Up in Alaska the Detroit Arctic Expedition has continued to have its troubles. Abandoning hope of ferrying enough gasoline to Pt. Barrow to carry out the scheduled flights of the big 3-engined Fokker, a start was made to take the small Fokker from Fairbanks and do the exploring in her. She had proved a thoroughly reliable ship after three round trips to Barrow. But she cracked up at the take-off. That left just the big Fokker, which previously had found it impossible to get over the mountains to Barrow with a full load of gas. And there was barely enough gas at Barrow to fuel her for a short exploration flight. Finally, by lightening the ship as much as possible, carrying only three men and a minimum supply of fuel, and by flying a roundabout path through the passes in the mountains, the big ship got to Barrow, where she has since been fogbound and unable to carry out the exploration flights over the unknown Arctic. Mason, as chief operator of the expedition, was to have flown to Barrow when the Fokker went, but they had to leave him behind because of these circumstances, so he is still at Fairbanks and Waskey is at Barrow. A party has been sent out to retrieve the abandoned generator for the ex-NRRL set and it is hoped that this station, signing KFZH, will be on the air at Barrow by early June. Meanwhile Mason and Waskey have been carrying on with their little battery-operated sets, maintaining remarkably good contact. In fact Waskey was copied solid on April 2d by Mr. G. W. Smits, OA60, of Hendrina, East Transvaal,

South Africa, while reporting to Fairbanks the safe arrival of Wilkins on one of the earlier ferrying trips! That was great performance. They have had other triumphs too, for Waskey saw Amundsen's "Norge" when it crossed the Alaskan coast and, sending down the news via Mason, gave the papers of the North American Newspaper Alliance a big scoop. The "New York Times" party, musing overland two months with portable station KDZ for that very purpose, were still some 35 miles out of Barrow when the "Norge" passed. Again Mason was the first to get the news out of Alaska when the "Norge" was located at Teller, and these communications arrange-



HOWARD F. MASON, 7BU, CHIEF OPERATOR OF THE DETROIT ARCTIC EXPEDITION, ALONGSIDE WILKIN'S FOKKER.

Note the single-bladed wind-driven generator. The curious mechanism on the right is the shock-absorber arrangement on one of the outboard landing gears

ments of the N.A.N.A. enabled their papers in the east to beat their competitors with the news by an hour and a half.

The main Wilkins party now will have to stay at Barrow until midsummer, when gasoline can be transported to them via steamer, before they can fly back, so the expedition promises to last considerably longer than was contemplated. The little battery-powered sets have not been reported heard in the United States, but Alaskan 7GZ and 7SM are in constant touch with them, and 7SM has a daily schedule with 6HJ in San Francisco, so that traffic for Mason or Waskey may be routed that way. With KFZH coming on shortly with the high-power set, direct communication with the States may be expected.

### The Amundsen Flight

The flight of Amundsen's dirigible, the "Norge," illustrated by the conspicuous

failure of its communications the great value of short waves to such exploring parties. The "Norge" was equipped with a "vertical bread-board" transmitter built by the British Marconi Co., putting 200 watts of C.W. in a trailing-wire aerial. Power was supplied by a wind-driven generator. The wavelengths were 600, 900 and 1400 meters, although 900 seems to have been used exclusively during the passage. Radio contact with Spitzbergen seems to have been satisfactory up to the time that the party neared the Alaskan coast. Then moisture started collecting and freezing on all exposed parts, until soon the wind-driven generator was a mass of ice and "froze up." The trailing antenna dragged on the ice and broke several times. The generator was used to charge the small batteries of the receiving set too, and soon the dirigible was unable either to receive or send. For two days an anxious world had no news of her. Twenty-four hours after the landing at Teller her radio officer had succeeded in overhauling an ancient spark station belonging to the Lomen reindeer ranch at that place and finally got word to Nome that the party was safe. What a pity that Amundsen did not carry high-frequency! This should be a lesson for all time.

### The Byrd Party

The "Chantier" (KEGK) of the Byrd Expedition, in London on the way home at this writing, has been maintaining fairly satisfactory contact with the States by short-wave radio. Many QSO's have been reported, a partial list of those reporting being 2NZ (who has been probably the most consistent contact), 1AMD, 1ACA, 1MY, 1CKP, 2CJE and 1AR. We have seen no reference to the employment of Hanson's 50-watt crystal set aboard the "Josephine Ford," KNN, the Byrd plane, during her polar flight, and apparently it was not used. KEGK's published schedules have been badly bailed up and have not been observed as published, probably partly due to the trying conditions under which the operators worked. Reported wavelengths have been .35 to 37.5 meters, 20 and 12m. Rumor now has it that shortly after their return to this country the Byrd party will shove off for the South Pole, to endeavor to be the first to conquer that pole by air too. If this voyage is undertaken, there will be some real short-wave traffic-QSO's for American amateurs.

KEGK's traffic to date has consisted chiefly of messages, the bulk of the "New York Times" press stories apparently coming via long-wave commercial radio from LCM.

**MacMillan Again**

The Rawson-MacMillan Sub-Arctic Expedition, under the auspices of the Field Museum of Chicago, is scheduled to sail from Wiscasset, Me., in June for another three-months northern trip, this time to upper Labrador and Baffin Land. The "Bowdoin," WNP, is again to go, and we understand that she will carry the same radio equipment that Reinartz had last summer, operating on 37 meters and 16 or 17 meters. We are advised that the Zenith Radio Corp. is selecting an operator, his name not yet announced. Contact with Canadian and U. S. amateurs is looked forward to for the maintenance of communication. A Zenith bulletin announces that amateurs receiving messages from WNP are requested to direct them to the Field Museum of Chicago.

**The Fonck Flight**

Although this isn't an Arctic expedition, this is as good a place as any to mention it. Capt. Rene Fonck, French pilot, in late June or early July will attempt a non-stop flight from New York to Paris in a special Sikorsky plane now under construction. It is expected that the ship will be equipped with short-wave radio and that a running account of the trip will be sent out as the 36-hour flight progresses. If these plans materialize, they will be announced by A.R.R.L. bulletin and broadcasts, as it is hoped that a large number of amateurs can maintain a continuous watch during the flight.

It's a great year for explorers!  
 Reports of QSO and intercepts to A.R. R. L. Headquarters, please.

—K. B. W.

**R. F. Chokes**

A very handy adjunct to any transmitter or receiver is the choke coil shown in the illustration. It is wound with one hundred and twenty turns of number 26 D.C. C. magnet wire, on a bakelite tube an inch

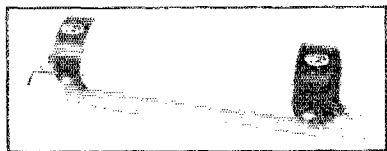

in diameter and three and a half inches long. The wire is large enough to pass the plate current of a couple of quarter kilowatt tubes, or the chokes can be used in a receiver. They are small enough to be located in the average receiver (or transmitter) far enough away from the inductances

to avoid any coupling between choke and inductance. Radio Engineering Laboratories of New York City make them, and on special order they can be supplied with any number of turns.

—J. M. C.

**Strays**

Arthur H. Lynch, formerly Editor of *Radio Broadcast*, is now in business for himself as Arthur H. Lynch, Inc., of New York City. The Company manufactures a number of radio devices, specializing in the well-known Metallized Resistors.

The following Commercial and Governmental general call letters have been assigned: NOB, general call for any and all warships; NQO, general call for any and all naval coast stations; WKW general, call for any and all merchant vessels and WTM, general call for any and all commercial coastal stations.

2BDO overloads his filament transformer so greatly that he uses it to roast peanuts on!

Additional crystal-controlled stations are as follows: 1CLN, 3AAI, 9AUG, and 9DHL. Drop us a line, OM, when yours is fixed up.

These pretty inductances were made by Don Short of 9BHS. The conductor is number 8 bare wire and the coils are formed

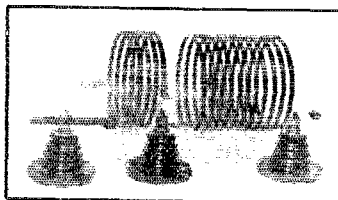

by drilling a hole in an iron pipe of the desired diameter, clamping the pipe in a vise and winding on the required number of turns. Then the end of the wire is clamped in the vise and the pipe is given a "heavy" turn by means of a Stilson wrench. The wire is drawn very tight and holds its shape. Copper lugs are soldered to each end of the wire and the coils are supported on G-R stand-off insulators. If this coil is not stiff enough for you, three small strips of celluloid may be glued on the wire with collodion.

# Short-Wave Receiving Sets

By L. W. Hatry\*

**I**N the field of short-wave receiving apparatus our practical sets are almost always limited to a regenerative detector with audio amplification to a suitable degree. Our attention is mainly focused on the design of such sets, yet certain points of design receive but little attention. This article wishes to call attention to these points.

## The Tuned Circuit

The tuned circuit comprising the input to our detector has been well discussed from the loss standpoint, in fact too well. The

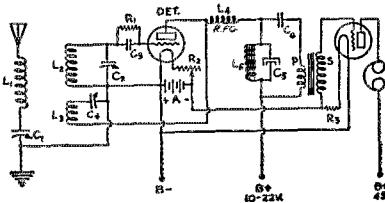

FIG. 1 THE COMPLETE CIRCUIT

- L1 Antenna coil.
- L2 Interchangeable secondary, carrying tickler L3.
- L4 Lumped R. F. choke.
- L5 1-henry choke coil, iron core.
- C1 Antenna series tuning condenser, maximum 500 micromicrofarads.
- C2 Secondary tuning condenser, maximum capacity about 45- $\mu$ fd.
- C3 Grid condenser, 100- $\mu$ fd.
- C4 Regeneration control condenser. The one in the present set has a max. capacity of 25- $\mu$ fd but for C. W. traffic work there is recommended a 500- $\mu$ fd condenser with a smaller tickler.
- C5 Trap tuning condenser, capacity 1/10  $\mu$ d.
- C6 Stopping condenser. See text for proper values for C. W. work. If phone work is to be done the trap is cut out and this condenser made very large or else removed in favor of feeding thru the transformer primary in the usual fashion.
- R1 Grid leak. Much of the set's performance depends on the correct choice of the leak. It must be quiet and must have a fairly high resistance (5 megs or more) for C. W. work. For phone work values as low as 1.5 megs. are O. K.
- R2 Detector filament rheostat, correct for tube used.
- R3 Automatic filament resistor, correct for type tube used.
- Tr Audio transformer with good amplification. General Radio 6/1 used here.

tuning range covered, however, seems to be a matter for continuous dispute.

The broadcast spectrum of 1,000 K.C. has been worked over so thoroughly that it of-

fers useful facts. Briefly these are that a band of 1,000 K.C. can be covered with a fair

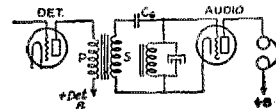

FIG. 2. METHOD OF FILTERING THE AUDIO TRANSFORMER OUTPUT INSTEAD OF THE INPUT

degree of rapidity of course depending on the operator's ability and familiarity with his particular set, and type of vernier. This can be satisfactorily accomplished by the use of a slow-motion control having a reduction ratio of 6/1 or 10/1 without unduly critical tuning and that it is helpful to do this with a variable condenser having something nearly on the order of a straight-line-frequency-calibration. The straight-frequency-line

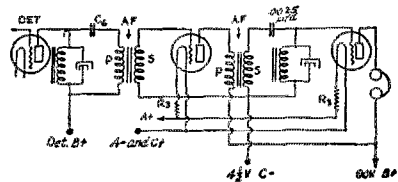

FIG. 3. PROPERLY FILTERED TWO-STEP AUDIO AMPLIFIER

It is important that the two stages are tuned to the same pitch.

condenser has been applied to short-wave reception but the lesson of the 1000 K.C. tuning-range has mostly been ignored.

## What Tuning Range?

When one begins to apply such a scheme as this there immediately arises the question—"What tuning range do I wish to cover? Do I wish to cover the entire territory of amateur wavelengths from 18.7 meters to 200 meters or will it suffice if I cover the U. S. amateur bands?" The reply depends on two things—the territory one is interested in and the number of coils one is willing to handle. For instance; if one decides to attempt to cover the entire territory just referred to it is quite impossible to retain the 1,000 K.C. idea without

\* IOX Radio Department, Hartford Times, Hartford, Conn.

a very large number of coils—18 to 24 depending on the overlap that is wanted. There are two ways out. One is to use fewer coils and give up the 1,000 K.C.-per-coil idea. This was done in the tuner designed by Fred Marco for the Aero Products Co. In this tuner the ranges approximately were as follows:

Coil	Wavelength bottom and top	Wavelength bottom and top	Frequency range of the coil
A	58 M	5200 K.C.	
	125 M	2100 K.C.	3100 K.C.
B	32 M	9500 K.C.	
	70 M	4200 K.C.	5300 K.C.
C	17.5 M	18,000 K.C.	
	35 M	9,000 K.C.	9000 K.C.

These are perfectly useful ranges, the scale is covered solidly with safe overlaps between the coils and the only remaining question is—would it be an advantage to go to a system which would give less cramped tuning at the expense of some complications or else a sacrifice of part of the tuning range?

The possibilities in this direction are best illustrated by discussing the various useful combinations.

**The U. S. Amateur Bands**

One popular type of tuner is the one which covers only the U.S. amateur bands and a small margin at either side of each band. These bands are as follows:

Wavelength in meters	Frequency at both edges and width of band in K.C.	Same in megacycles
150	1,999	1,999
200	1,499	1,499
	500	.500
75	3,998	3,998
85.7	3,498	3,498
	500	.500
37.5	7,995	7,995
42.8	7,005	7,005
	990	.990
18.7	16,030	16,030
21.4	10,410	10,410
	5,620	5,620
4.69	63,930	63,930
5.35	56,040	56,040
	7,890	7,890

Without going down to the 74-centimeter band at all one can see that the same tuner will not cover this entire region easily. The "5-meter band" requires special apparatus while the "20-meter band" is so wide as to suggest that a practical compromise will be to stick fairly close to the 1000 K.C. idea for the three upper bands (or lower bands if we speak of frequencies) but to put up with the 5600 K.C. tuning range when working in the "20-meter" band.

A tuned circuit covering the 150-200 meter (2000-1500 K.C.) band requires a ca-

capacity range of only about 2/1. For this the ordinary three-plate variable condenser with a capacity of about 45 micromicrofarads is about right. The same condenser has too high a capacity range for the 20-meter band as it can be made to tune over a wavelength range of as much as 18-36 meters which is equal to an enormous fre-

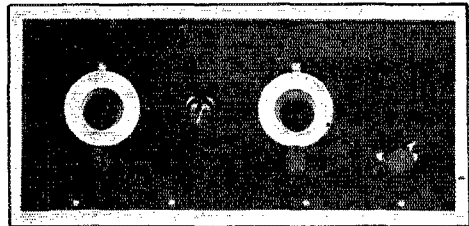

**PANEL OF THE SET**

The controls from right to left are, filament rheostat, secondary tuning condenser, regeneration condenser, antenna tuning condenser.

quency range—8,330 K.C. To use the same variable condenser for the 18-21 meter waveband only, the coil should be made small and a small fixed condenser (pair of

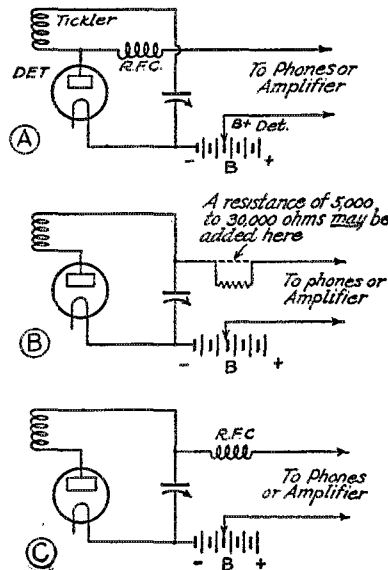

**FIG. 4. VARIATIONS OF THE WEAGANT REGENERATION CONTROL**

metal angles) connected across the variable condenser. This does not harm the signal strength as much as might be expected since in any case the minimum capacity of

the variable condenser, plus the tube capacity is likely to be some 15 times the distributed capacity of the coil. The L/C ratio therefore does not become so very much worse if all things are considered.<sup>1</sup>

In any tuner design some compromises must be made between the number of coils and the degree of tuner crowding. In the

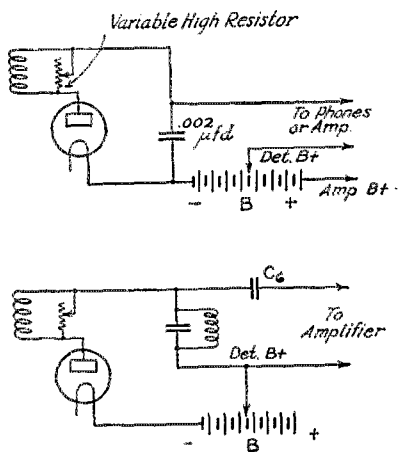

FIG. 5. RESISTANCE METHOD OF CONTROL-LING REGENERATION  
A With usual audio amplifier.  
B When using tuned audio trap.

tuner which is described here, and the coil dimensions of which are given in Table A, some additional territory has been taken in on each side of each amateur band, covering the territory which the writer finds most interesting. To cover the entire region would require 3 additional coils but would permit narrowing down the range (and opening out the tuning) of the present 4. In the 20-meter (15,000 K.C.) region crowding has been accepted because this region takes second place in point of general usefulness.

### Antenna Tuning

The next useful thing is tuning the antenna circuit. Exact tuning seems to be of little advantage for short-wave C.W. reception though it is helpful for 'phone reception. Since exact antenna tuning is not necessary, the methods of getting it over

<sup>1</sup> The Technical Editor has lately been trying tuners with widely varying L/C ratios in the secondaries. When adjustable regeneration and adjustable antenna coupling has been employed there has been surprisingly little difference in the results as to actual reception. This sort of tests is crude but suggests that possibly the L/C ratio has not the great practical importance we have assumed.—Tech. Ed.

a wavelength range are clumsy and the antenna resistance is high in any case we can very well revert to the well-known switch, connected to a tapped antenna coil. A little experimenting will result in an antenna coil which will cover all the amateur bands, either by direct tuning or by harmonics. Very loose coupling is necessary or the calibration of the secondary circuit is affected. The set of the photographs does not use this scheme but employs a fixed (although plug-in) antenna coil with a variable series condenser. The writer's aim in assembling the set was originally to tune the antenna circuit to the wavelength being received, thereby controlling the regeneration by introducing antenna resistance. This however could not be done over the wide range of amateur wavelengths with any fixed degree of coupling between the antenna and secondary coils so it was in part abandoned. Many others besides the writer have doubtless had the same idea. Two years ago he had correspondence with someone who used both a tuned antenna circuit and variable antenna coupling. Later Mr. Service of the A.R. R.L. headquarters' staff used such an arrangement, mostly controlling oscillation with the antenna tuning adjustment. He did not bother with exact antenna resonance. R. B. Bourne of IANA has a scheme which amounts to antenna tuning. All of these, however, have the obvious fault of adding a third (and critical) control, and a set with two critical controls is an operating monstrosity.

In spite of this, exact antenna resonance is valuable and can possibly be combined with the regeneration control in the way suggested. Therein is a road to improvement which may be tried by the experimenter who is really trying to improve short-wave tuners.

### The Grid Condenser and Leak

Since the secondary circuit tuning condenser is of very low capacity it is necessary to avoid adding external fixed capacity. The present set uses a 100-micromicrofarad grid condenser instead of the usual larger values. R. B. Bourne is said to use a grid capacity of 10 micromicrofarads. Simple calculation shows that if this is carried to the extreme of using a 2-micromicrofarad condenser there may be an excessive voltage drop in the reactance of this condenser so that the grid will not receive the full input from the tuned circuit.<sup>2</sup> When using such a small grid condenser as the writer has suggested the size of the tickler must be increased.

<sup>2</sup> By cut-and-dry methods (as crude as those of note 1) I have arrived at a rule-of-thumb to the effect that a grid-condenser capacity of a microfarad per meter is not far wrong for UX-199 tubes.—Tech. Ed.



**Regeneration Control**

The writer has controlled regeneration in short-wave receivers with about every possible device; variometer, tickler, absorption circuit (Cockaday scheme), series variable condensers, by the Weagant system and by variable resistances. These might be reviewed if *QST* could spare the space. Suffice it that we want (as *QST* has said before) a regeneration control that does not tune. This resolves itself into a tickler that has no mutual inductance with relation to the secondary, which is impossible, of course. It then seems impossible that a non-tuning regeneration control can exist

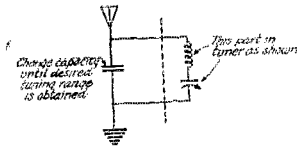

**FIG. 6. A METHOD OF INCREASING THE TUNING RANGE OF THE PRIMARY CONDENSER**  
This scheme also seems to reduce the radiation while it definitely does not decrease signal strength.

but practice will quickly show that it may. A small<sup>3</sup> tickler close to the filament end of the secondary and rotatable will show minimum tuning effect but it seems impossible to get entirely away from tuning effect where a movable tickler is employed. An absorption circuit will produce no tuning effect if the secondary circuit is of low resistance but adds a critical control which is a decided disadvantage.<sup>4</sup> The control of regeneration by a series variable condenser (variable stopping or bypass condenser) in the R.F. part of the plate circuit is another method that works if the variable condenser is comparatively large as many of us have found in using the so-called Weagant arrangement. This scheme works if the tickler is very small in diameter, presents small surface to the secondary and is at the filament end of the secondary (as in the sets built by Clayton and described in August, 1925 *QST*) or if the tickler is of the same diameter as the secondary, is on the filament end of the secondary and is separated from the secondary by a space which may be anything from 1/2" to 2",

<sup>3</sup> That is of small diameter.—Tech. Ed.

<sup>4</sup> It is a relief to find someone who checks the editor's observation that the absorption circuit is a critical adjustment. I have always found that the device works exactly as does a wavemeter used in the "click method" and indeed see no difference between the two things. Has anyone any evidence to the effect that absorption circuits can actually be made to work as stated in popular articles i. e. with the regeneration growing less and less as the absorption-circuit condenser capacity is increased, regardless of the secondary tuning?—Tech. Ed.

depending on the number of tickler turns and the diameter of the secondary. That it is possible to operate this last arrangement with negligible tuning effect will be confirmed by many amateurs who have copied the arrangement used by Schnell. The Weagant method can be used in several ways as Figs. 4A, B and C indicate. The R.F. choke is least likely to cause trouble in the circuit which gives it the least work, which is B, in Fig. 4. Since the choke makes it possible to reduce the size of the tickler in this arrangement it should be used. Fig. 4C, the writer believes to be the best of the various Weagant arrangements for it offers the practically negligible tuning effect characteristic of the Weagant arrangements, does away with the R.F. choke troubles and is entirely non-critical. It is only necessary to use a condenser that is large enough—at least as much as 250-micromicrofarads and perhaps as much as 1000-micromicrofarads.

Then there is the resistance control of regeneration which also has the advantages mentioned above with the additional one of being less bulky than a variable condenser. Its use is as in Fig. 5 where the 250-micromicrofarad bypass condenser is large enough to permit the use of a small tickler. The variable resistance R can be a "Clarostat" in preference to most others

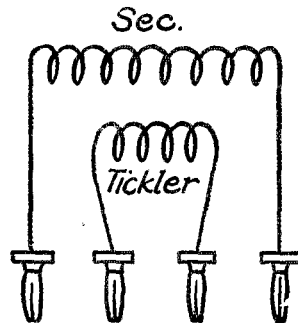

**FIG. 7. ARRANGEMENT OF THE SECONDARY AND TICKLER**

because that device has a very wide resistance range. I have not made any comparisons of sensitivity or signal strength between these regeneration controls, there is no reason for making them as regeneration is still regeneration, however it is obtained. The only important thing is the ease of controlling the regeneration and the freedom from tuning effect.

Note especially that the use of a large condenser has been recommended, where the condenser is used to control regeneration. There is good reason; the use of a small condenser demands more tickler turns, multiplies the R.F. choke difficulties and (because the tickler is larger) in-

creases the tuning effect of the regeneration control. The set shown in the photographs, does not live up to this statement, but it should.

### The R.F. Choke

The R.F. choke used in this set is lump-wound. The writer finds that with the Weagant arrangement it is especially im-

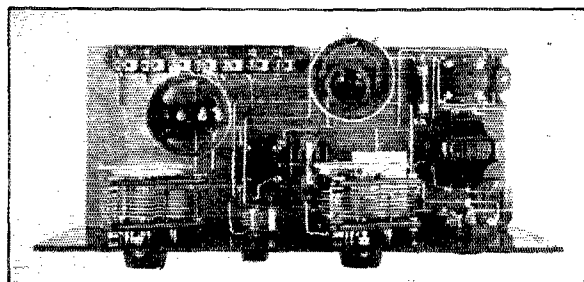
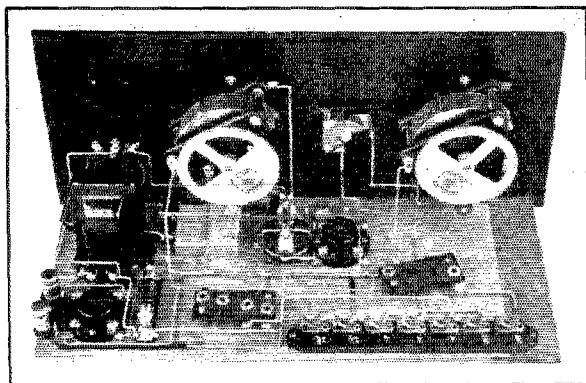

#### THE MACHINERY

First of all note the extremely loose coupling which makes the secondary tuning independent of the antenna used. If you have not figured it out we will tell you that the coupling to the antenna coil is due to the fact that the two coils are on the same board, parallel, and about 4 inches apart. Just back of the detector socket is the small R. F. choke and underneath the secondary tuning condenser is the tuned audio trap. The white object is the Tobe condenser while the open core choke is the dark cylinder.

portant to avoid dead spots—that is, points at which the detector refuses to oscillate because of the tuning characteristics of the choke. The present choke was wound directly on an iron screw which may have something to do with the fact that so far no dead spots attributable to the R.F. choke have been found. The winding of the choke consists of 400 turns of No. 32 S.S.C. wire. The small bulk of such a choke is a decided advantage.<sup>5</sup>

### The Audio Circuits

We have for a long time been asking for peaked high-ratio audio transformers. There has even appeared a tuned audio transformer. All of this has been more or less dissatisfactory.<sup>6</sup> In general the best of the modern music transformers amplify practically as well as the tones used in C.W. reception as do our peaked transformers and will in general work quite as well for C.W. if worked with an audio filter as shown in Fig. 11 which is reproduced from page 32 of April QST. A somewhat better arrangement is shown in the complete circuit, Figure 1. The writer used a 1/10-microfarad Tobe condenser and a 1-henry Kellogg iron-choke to make the tuned trap. The constants of one or both of these parts were not as marked, resulting in a lower frequency than that intended. This hurt nothing as the autodyne method of reception enables one to adjust the tone to the value that comes through the trap best—or rather that is best rejected by the trap and goes through the transformer. Notes that have modulation (not using pure D.C.) are heard best if the tuning pitch of the trap is not too high. Of course the usefulness of such a trap in "static" weather is obvious and its usefulness in interference will be appreciated after it has been tried.<sup>7</sup>

The secondary circuit can be filtered in the way suggested in Fig. 2. This will be practically as effective as the primary filter. This arrangement seems to give slightly lower amplification.

The filtering of two stages with two filters makes the frequency selection too critical so that the notes which waver slightly seem to fade very badly, yet in the long run we are coming to just that sort of a thing as the number of stations on the air increases. We will then be compelled to use steady notes and sharply selective audio amplifiers that respond only to the note that has been set to the amplifier

5 The small "honeycomb" coils used as windings for intermediate frequency interstage transformers (superheterodyne) seem to work at least as well as the more common single layer chokes.—Tech. Ed.

6 It hardly seems that hopeless. I too like the scheme here given, but feel that the simpler peaked transformer deserves consideration.—Tech. Ed.

7 In the article referred to (page 32 of the April issue) I stated that the condenser here called C6 should have a capacity of at least 1 microfarad. This is correct only if the same amplifier is to be used for music work with the switching arrangement I showed. For purely telegraphic work the capacities here mentioned are O. K.—and much cheaper.—Tech. Ed.

pitch, which should be chosen to suit the ear of the operator. A good method of filtering a 2-stage audio amplifier is shown in Fig. 3. First class fixed condensers are necessary; haphazard material will not do save for a 1-stage affair. For the man interested in filters, the Dellenbaugh articles in back issues of QST are excellent. Get out your files.

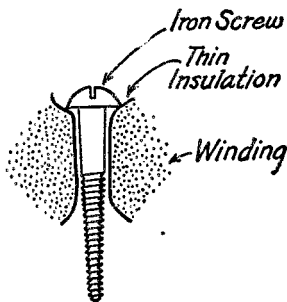

FIG. 8. THE R. F. CHOKE

The condenser C6 (Fig. 1) has been experimented with from .001 to 16 microfarads. From about .005 microfarads up there is no increase in the C.W. signal strength ex-

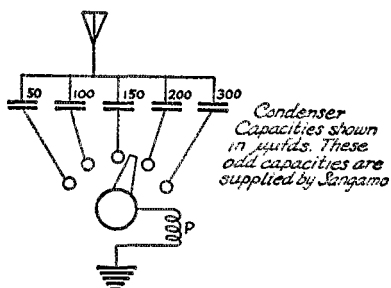

FIG. 9. ANOTHER SCHEME FOR SHIFTING THE ANTENNA TUNING RANGE TO AVOID DEAD SPOTS AND TO GIVE BEST RECEPTION IN EACH HAND

cept in the strength of the interfering extraneous noises. The condenser C6 controls the selectivity of the trap to some degree.

### Constructional Details

In the tuner which is shown in the photographs, the principles discussed have been made use of in some degree. General Radio coil forms with spring plugs are used. The

antenna coil has two plugs while the secondary coil form has four, the extra two being used for tickler connections. The coils (except the 40-meter one) have their tick-

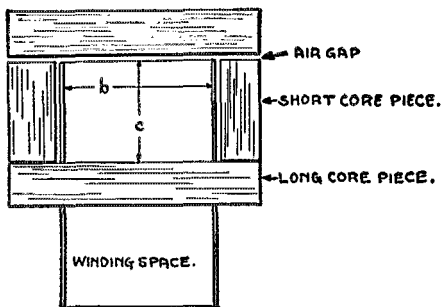

ARRANGEMENT OF INDUCTANCE COILS.

FIG. 10. CONSTRUCTION OF A 1-HENRY IRON-CHOKE AS DESIGNED BY F. S. DELLENBAUGH

This choke will handle 50 milliamperes but a smaller one is hard to build.

The dimensions b and c  $\frac{1}{2}$  and  $\frac{1}{3}$  inch respectively. The long core pieces measure  $\frac{1}{2}$ " by .55" by 1.7" while the short ones measure  $\frac{1}{2}$ " by .55". Slight variations to the nearest convenient dimension are not serious as the airgap can be adjusted to compensate. For the dimensions shown the airgap is .019" and the core  $\frac{1}{2}$ " thick. The winding consists of 2300 turns of No. 33 enameled wire.

lers inside. The secondary should be connected so that its terminals come to the two outside plugs, while the tickler terminals hit the two inside plugs as in Fig 7. Reversing the coil in the jack-strip then does no harm as both coils are reversed together. White annunciator wire (No. 18) is used except where otherwise specified.

The antenna tuning condenser is a General Radio type 247 with a maximum capacity of 250 micromicrofarads just as purchased, but the secondary tuning condenser (originally of the same sort) has been cut down. All of the stator plates are present but only two rotor plates remain, the rest having been unsoldered and removed. The regeneration control condenser is a Silver-Marshall midget with a rated maximum capacity of 25 micromicrofarads.

### Changes in the Tuner

As has been said, the regeneration control condenser may with advantage have a larger capacity when C.W. reception is the purpose. However the wavelength ranges given for the coils are true only with the ticklers shown in Table A and if a larger condenser is used the ticklers will need to be changed, thereby changing the tuning range of the coil. For instance a certain

secondary coil tuned down to 37.5 meters with a 15-turn tickler (such as would be used with a larger regeneration condenser) but tuned down no further than 43.5 meters when used with a tickler of 25 turns which was correct for smooth regeneration over

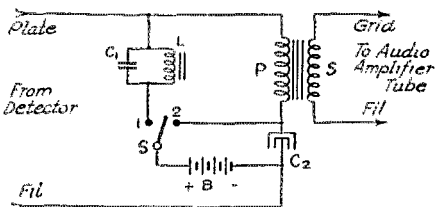

FIG. 11. AUDIO FILTER CIRCUIT ADAPTED TO EITHER PHONE OR C. W. WORK

By putting the switch on the point 2 the trap is cut out so that flat-curve amplification is obtained. If for phone reception audio quality is desired the condenser C2 (called C6 in the other diagrams) must be made larger than for C. W. work.

the entire scale with the midget regeneration condenser used in the present set.

Coil dimensions for Weagant Regeneration control.

Wavelength Range 100 uufd grid condenser and UX 199 tube	Same for 201A tube	Secondary turns	Tickler turns
145 to 225	52 No.25 D.C.C.	70	No.26 lumped
70 to 93	73 to 98	20	31 lumped
33 to 51	36 to 53.5	8	8
18 to 28	—	4	6

Coil dimensions for Resistance regeneration control

70 to 93	—	22	10
33 to 51	—	10	3 or 4
18 to 28	—	6	3

All secondary windings on General Radio 2 $\frac{3}{4}$ " bakelite plug-in forms. Ticklers marked "lumped" are 1 $\frac{1}{2}$ " in diameter and placed inside the form at the filament after the fashion of the 80-meter coil shown in the set photograph. The other ticklers are wound of No. 18 bell wire, on the same form as the secondary and next to the filament end of the secondary, with a small space between the two coils. The secondaries (except where noted) are wound with No. 18 bell wire, white cotton covered, though it would be just as good to use striped annunciator wire or any other No. 18 wire as long as the same spacing was preserved.

## Legislative Note

UP to our closing time there has been but one noteworthy development this month in the radio legislative scramble. The Senate Committee on Interstate Commerce finally reported on its deliberations and presented a new bill, the third by Senator Dill with a recommendation for its adoption. To expedite action, the bill is known in the Senate as H.R.9971 with an amendment. H.R.9971 is the White Bill, as passed by the House and referred to the Senate. But the bill in the Senate has no resemblance to Mr. White's bill, the amendment taking form of striking out all particulars and inserting Senator Dill's newest confection. This would provide for the control of radio by a commission of five, supreme in their authority, without appeal from their decisions.

Such a bill is bad not only for amateur radio but for all of radio. But it hasn't passed yet and in our opinion it isn't likely to. Very probably it will pass the Senate, if that body gets around to voting on it, but it would then go to conference committee where it will encounter the House proponents of the White measure. There a more reasonable view probably will result in some form of compromise proposal, which may or may not pass both houses. All of this first depends upon the Senate getting around to the radio subject before adjournment for the summer. No bets taken.

—K. B. W.

## Information Service Rules

- 1—Before writing, search your files of QST. You will probably find the answer there.
- 2—Do not ask for comparisons between advertised products.
- 3—Be reasonable in the number and kind of questions you ask.
- 4—Put questions in the following form:
  - A—A standard business size (not freak correspondence size) stamped, self-addressed envelope must be enclosed.
  - B—Write with typewriter or ink on one side of sheet only.
  - C—Make diagrams on separate sheet and fasten all sheets together.
  - D—Number each paragraph and put only one question in a paragraph.
  - E—Keep a copy of your letter and your diagrams.
  - F—Put your name and address on each sheet. *We cannot spend time digging your address out of the callbook.*
  - G—Address all questions to Information Service, American Radio Relay League, 1711 Park Street, Hartford, Connecticut.

## “Rotten Radio”

By One of the Old Men

**S**AY, I don't usually go off the handle on anything relating to our great old game, but there is one thing that gives me a violent pain in the neck, and that is the crowd that continually hollers, “Radio ain't what it used to be,” (sniff, sniff) “Alas, for the good ol' days that was,” etc., etc.

Now, I'm one of the old men, and proud of it, but by heck I don't agree with these alleged brothers of mine who swear by a band of condensers that there ain't any kick in this present-day tweet-tweet gargle-gargle stuff called C.W. Nossir, not by a darn sight I don't.

Hist! My private opinion is that a lot of those old timers got left behind in the rush, and that this martyr and tragic dignity stuff is just an alibi like stunt to justify their inability to keep up with the youngsters. Absodamntively!

Now, as I stated, I can rate as a pretty old socker, and by golly I am here to rise up on my hind legs and state that those “good old days” can't touch the present one. All right, c'mon, I'll take on the whole bunch of yuh, but I stick by them statements.

Just what kind of radio *did* we have in those by-gone days? Well, lemme see—we had nice healthy Betsies (salaams to T.O.M.) and we had big antenny systems that costs a pile of rocks to put up, and a bigger pile to make 'em stay there. Then we had large chunks of nice hi-voltage condensers—that were continually getting shot to the accompaniment of loud curses and wails from the owners. (You tellem Dubilier.) Believe me, the transmitting game cost you something then.

And how about receivers and parts, hey? I usta have three catalogues in my shack—Duck's, Adams-Morgan's, and the E. I. Co. But even with them you couldn't get what you wanted. When Paragon Paul brought out that nice job of his, variometers were the Old Man's cat's whiskers, but try'n get 'em! N-o-t-hing doing! The same with variocouplers. They didn't grow that kind of tree in those days. You had to make your own. Radisco (remember?) did bring out some nice ones, but they sure cost a pile of jack.

And “B” batteries and amplifiers! Remember the old three-stage audio amplifier that Mesco usta sell for \$1000—minus 50% discount? And “B” batts had to be soldered up from flashlight cells that you got at the ten-cent store. Nowadays you can have an amplifier for almost nothing, and lookit the nice, neat little “B's” you can get.

Good ol' days? Applesauce!

And lemme tell you, you young squirts, that DX wasn't all it has been cracked up to be by those die-hards, either. Why I can remember the days when ACME made some of their best ads out of the fact that somebody in Podunk had been heard 500 miles with one of their over-loaded quarter-kilowatt sparks! 250 watts—500 miles! Shades of waste energy!

Good old days? *Razzberries!*

'Twant as easy to work through each other then, nuther. “QRM” got used a lot more then than “Pse QSL” does now. In my town there were two he-stations and a flock of little spark-coil fellows, and buh-lieve me Mabel it was absolutely nothing doing from 200 to 400 meters when either of those big babies opened up. You just took the cans off and read a book a while. Finally, the two big birds got tangled up in a private QRM war, and between them nearly killed off ham radio for a while as far as the rest of us were concerned.

Nowadays a dozen fellows can work with-in as many blocks of each other, and never know it. C.W. duzzit. Good old days? Bl-a-a-a-h!

Well, I eventually got my big spark, too, and I liked that beloved old concrete-mixer as much as the next fellow. C.W. came along, and for a time I wouldn't touch it, and darn near wrote hot letters to dear old QST because they dared take up space with such stuff.

I was getting all set for the undertaker,

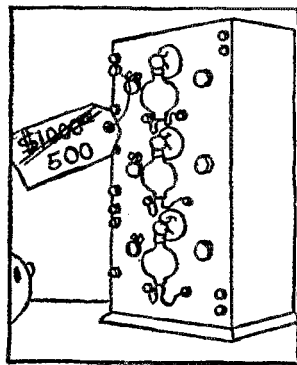

and didn't know it. But I woke up when one of the kids (I always looked on him as an ignorant newcomer) who lives not so far away informed me that he had worked

Denver with a couple of old Western Electric 5-watters. And me bragging about the same feat when I took two kilowatts in a one-kilowatt transformer to do it, and drained most of the juice outta the taown's light system to do it. Say, I got a shock, and rubbed the sand outta my rheumy old eyes, and by cripes I found that the old radio game was just about to regulate me to the ash-heap as an old stick-in-the-mud who wouldn't admit that progress is progress.

Well, I had to step to catch up and keep up, but the old boy ain't dead yet, not by a couple of jugsful, and he's holding his own with the rest of the kids. Sure I have the old spark—in the cellar—but it is a couple of fifties that is doing all the heavy dxing.

They do say as how the ham spirit isn't what is usta was. Well, mebbe not quite so much; but give 'em time—give 'em time. We had our dx-crazy period too, only it just happened that there weren't any old-timers to rail at us during that stage. I don't see why these new youngsters ain't entitled to theirs, too. They'll learn. Look at the Rag Chewer's Club—lotta members. I'm one, and there are lots more, and the number is increasing all the time. The old spirit is there, or there wouldn't be any R.C.C. Ain't I right—ain't the old mar keereet? Y'betcha, he is!

Nossir, the next time you hear any old graybeard yelling about the good old days, you just make up your mind that he is too old to learn. The Chinese are his class—they won't believe in progress, either. Me—I'm keeping up with the procession, and reading our *QST* (it's better than ever before, too) each month to make sure I don't lag.

Good ol' days? HORSE RADISH!

## 8GZ Wins Jewell Contest

By John H. Miller\*

**T**HE Jewell 1925-26 prize contest has been won by Mr. L. G. Windom, 8GZ and 8ZG, of Columbus, Ohio.

The work was done with a 199 type of tube with four volts on the filament and from 70 to 75 volts on the plate. The total filament and plate watts ran from .49 to .57.

In April *QST* 8GZ's low-power work was mentioned. Here are the outstanding records.

From 8:10 to 8:50 A.M. E.S.T. on December 30th, 1925, Mr. Windom was in communication with Australian 5BG, Mr. H. A. Kauper, 20 Gruney Road, Dulwich, Adelaide, South Australia. The distance figures 10,100 miles and the total input was .567 watts, giving a record of 17,820 miles

per watt. Mr. Kauper acknowledged the transmission with a very detailed letter giving facts which confirm the transmission beyond a doubt.

At 12:30 A.M. E.S.T., January 3rd, 1926, communication was established with O-A6N, Major J. G. Swart; M. C., Cambridge House, Milnerton, Capetown, South Africa. The message was acknowledged by letter confirmation. Distance checks up 8,250 miles from Columbus, Ohio. The total input was .54 watts, giving a record of 15,280 miles per watt.

On February 28th, 1926, from 2:12 to 2:53 A.M. E.S.T., Mr. Windom worked Z-2XA, Mr. Geo. H. Shrimpton, 38 Rongotai Tee., Wellington, New Zealand. The distance figures 8,500 miles, and the wattage was only .493 due to a lower plate voltage, giving a record of 17,250 miles per watt. The transmission was acknowledged by Mr. Shrimpton.

Mr. Windom also communicated with other stations using a 201-A, where the power ran up to about 2 watts.

The transmitter with which the work was done was shown on page 43 of April *QST*. Efficiency must have been considered foremost when building the set, and it seems to have paid.

Using the same set, communication has also been had over the United States, from Charlotte, North Carolina, to as far West as Kansas City, beyond which the ground wave evidently fades out and the reflected wave comes into play at the greater distances.

Practically all of this work has been done at 40 meters.

It is rather interesting to note that the receiving sets used by the station hearing 8GZ were in no way unusual, most of them being an ordinary detector and one step audio. The transmission efficiency must not be credited to abnormal receiving equipment.

There were quite a number of entries in the Jewell contest, although most of them used 201-A tubes, and did not come anywhere near Mr. Windom's figures for distance.

The antenna ammeters have been sent to the leading man in each district.

Ask Mr. Windom to show you the Jewell watch the next time you see him.

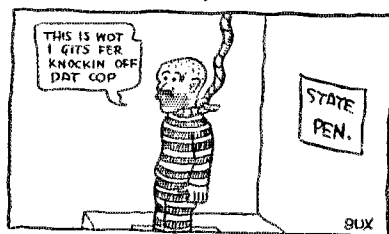

\* Electrical Engineer, Jewell Electrical Instrument Co., 1640 Walnut St., Chicago, Ill.

# Transmitting Coils

By F. E. Handy, Communications Manager

**T**HE best coils to use in a transmitter will be of small enough diameter so that the clips can be adjusted without running leads around to the other side of the coil. Theoretically, coils have only the property of inductance. Practically, all coils have some distributed capacitance. They also have resistance depending on the material and shape of both

## Construction

About half our active transmitting stations can use only the 40- and 80-meter band. There is little reason for this. To work in the 20, 40, 80, and 200-meter bands all that is necessary is a group of easily built coils. Such a group is shown in the photograph.

On two short pieces of hard rubber or micarta tubing (or wooden ends for that matter) are bolted six notched hardwood strips that have been boiled in paraffin. Cut a strip of paper which will just go around the micarta tube, divide it into six parts, when it lies on the table then wrap it around the tube again and drill holes for brass machine screws where the marks on the paper appeared. For a transmitter using a pair of 203-As, or 204-As, flatwise wound strip  $\frac{3}{8}$ " or  $\frac{1}{2}$ " wide and spaced by its own width will be useful. The best thing for all around use however will be a group of coils of  $\frac{1}{4}$ " brass or copper strip. Brass holds its shape better. A good coil will improve even the receiving tube transmitter. It will still be useful when we put in a real transmitter.

In laying out the wooden strips they can all be put together in a miter box and k notches sawed  $\frac{1}{4}$ " wide,  $\frac{1}{16}$ " deep and  $\frac{1}{4}$ " apart. Make the notches just a shade

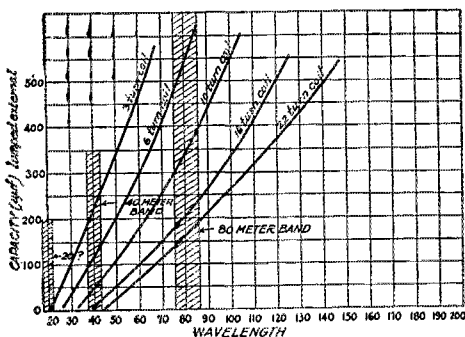
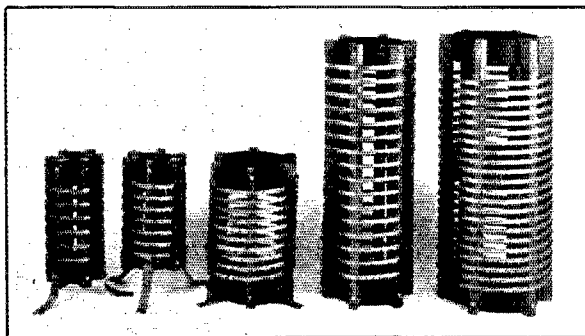

FIG. 1. TUNING CURVES FOR  $3\frac{1}{2}$  INCH COILS Wound with  $\frac{1}{4}$ " strips spaced  $\frac{1}{4}$ " apart. Wavelengths given are for condenser across entire coil. This is somewhat closer spacing than shown in the coil B in the photograph as the curves are from data obtained on some coils made and measured by John M. Clayton, Assistant Technical Editor.

the winding and the winding form as well as the frequency of the current. High frequency currents travel on the surface, not the inside of the conductor.

Edgewise wound coils are unsuitable for use in a Hartley circuit at wavelengths shorter than 100 meters. With such coils the Hartley circuit degenerates into an arrangement in which the external plate impedance adjustment interlocks hopelessly with the tuning adjustment. It is impossible to change the "plate turns" without changing the wavelength also. This is so because the distributed capacity of the coil is so high that little or no primary condenser can be used. If we adjust our plate turns so that the tube gives us good efficiency we find ourselves off wavelength. Shifting the wavelength to work within the amateur band results in loss of efficiency. To get out of this situation one needs coils with low distributed capacity. Flatwise wound helices have lower distributed capacitants than edgewise wound helices or pancake coils.



## A COMPLETE SET OF EDGEWISE COILS

The two coils at the right are loading coils, the three at the left are the coils A, B, and C reading from the left referred to in the table. They are interchangeable in a set, having a hinged antenna coil which can be swung out of the way to prevent change of primary coils.

wider than the strip and leave  $1\frac{1}{2}$ " or so of extra length at the end of each strip. After the strips have been cut slide them edgewise so the groove slants across the row of sticks just as the winding will slant and then cut all the ends off square at once.

**Tuning Curves**

The three coils at the left of the photograph will cover the amateur bands very

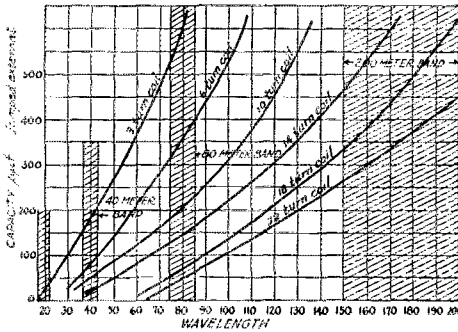

FIG. 2. TUNING CURVES FOR 5" DIAMETER COIL WITH THE SAME SPACING AS IN FIG. 1

nically with proper tuning condensers. Tuning curves are shown to give the beginner his bearings; the advanced amateur should use his wavemeter.

**Effect of Tubes**

Naturally the wavelength of the coil-and-condenser combination will be a little lower

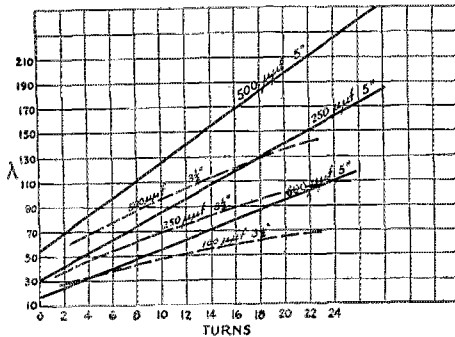

FIG. 3. CURVES FOR 3 1/2" AND 5" COILS OF 1/4" STRIP WITH 1/8" SPACING BETWEEN TURNS than the wavelength gotten when a transmitting tube is connected to the coil in addition. However fairly good lumped ca-

Table 1

Wavelength-band	Max. Cap. of Turns flat-Coil	variable tuning wise wound	Spacing	Coil	
	diameter	condenser	1/4" strip	Coil	
150-200 meters	5"	.0005	10-12	1/4"	C
	(or a .00025 with a fixed .00025 cap shunting it)				
75-95	5"	.00025	10-12	1/4"	C
37.5-42.3	3 1/2"	.00025	7	3/8"	B
18-22	2"	.00025	6	1/2"	A

pacities are being used and the effect is smaller than one would think.

The effect of changing from one receiving

tube to two 5-watt tubes was to shift the wavelength from 21 meters to 22.3 meters. In the higher wavebands the effect would be too small to worry about. Using a single 5-watt tube the number of plate turns could be changed from 1 to 7 while shifting the wavelength from 19 meters to 20.6 meters. Again the effect would be negligible in the higher wavebands. These things go to show that the wavelength ranges given are nearly enough right to be useful.

**BOOK REVIEWS**

By R. S. Kruse, Technical Editor

**Radio Communication**, Ellery W. Stone, Lientenant Commander U.S.N.R., published by D. Van Nostrand Co., 8 Warren Street, New York City, 433 pages, 220 illustrations, price of third section \$2.50.

Either my digestion has improved or else the grade of radio books is rising steadily. It has been quite a while since it has been hard to say pleasant things about a book. Of course when a book is written by Ellery W. Stone there is no possibility of saying anything unfavorable. The mechanical makeup of the book is pleasant and the contents live up to the promise made by the appearance of the book.

The balance obtained is unusual and gratifying, the various branches of radio are treated with proper regard for their relative importance and with a fine correctness as to authorities and sources. In every chapter there is introduced the man who made this or that contribution. The commercial communication system of the Federal Telegraph Company is usually ignored by books originating with east-coast authors. From this error the present book is free.

In every way but one, the present reviewer likes this book thoroughly and recommends it heartily. The one exception is that from this book there can be learned very little indeed of the very vital contributions made to the radio art by such amateurs as Boyd Phelps and John Reinartz nor is there much reference to the American Radio Relay League. Perhaps that last sentence should be labeled "Advt."

**Strays**

Frank Henry, 8FP, of 211 Norwood Avenue, Buffalo, is prepared to check QRH's of any of the gang. Either arrange a schedule with him via mail or call him almost any night. The accuracy will be within one tenth of one per cent.

1BWB says a grave error has been made—Ballantine's book has referred to as the Hams Bible. Not so—QST is the Bible and Ballantine's book The New Testament.

A copy of the Constitution and By-Laws of the League, revised to date, will be sent to any member upon application to Headquarters.



## Short-Wave Wavemeters

**W**ITH the number of good and moderately priced short-wave wavemeters that are now available, there really is no excuse for any amateur not owning an "off-wave" measuring device. In addition to being the most valuable asset to the amateur who operates within the law, a wavemeter has a wide variety of other applications in the amateur station. In the columns of *QST*

wavelength range is from 14 to 240 meters, the individual coil ranges being 14 to 30 meters, 25 to 60 meters, 50 to 115 meters and 100 to 240 meters, good overlap being provided between each coil. The condenser has the G-R geared type of vernier having a ratio of about six to one. In place of the direct reading scale which was used with the 247-W type, the new meter is supplied with a calibration curve for each coil, every meter being individually calibrated. The resonance indicator is a small lamp connected between the condenser and the coil. The socket for the lamp is arranged to automatically short-circuit when the lamp is removed. With the lamp out of the circuit better indication can be secured through the click method since the resistance of the lamp is out of the circuit.

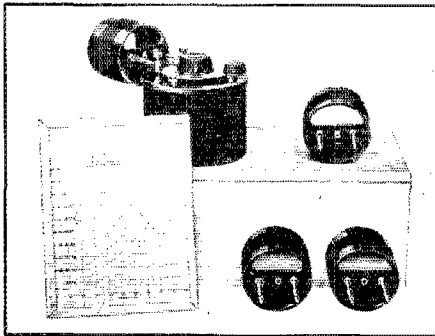

GENERAL RADIO TYPE 358

for many years wavemeters have been described, and uses for them recounted. We need not go over the operation of a wavemeter now.

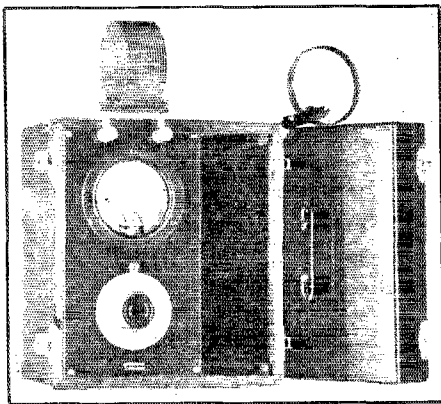

J. GROSS & CO'S SHORT-WAVE METER

The new General Radio type 358 looks similar to their old type 247-W. There the similarity ceases. The meter consists of a modified 247 condenser in a metal can, four inter-changeable coils and a lamp indicator. With the four coils provided the

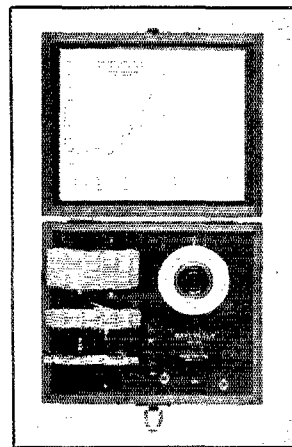

RADIO ENGINEERING LABORATORIES TYPE A

The J. Gross & Company have two models of short-wave meters. One is equipped with a thermogalvanometer resonance indicator and the other a flashlamp. The meters are provided with two plug-in coils giving ranges of 20 to 80 meters and 70 to 200 meters. The coils are of the Hammarlund space-wound type and are extremely rugged. They are fitted on plugs fitting two binding posts. General Radio dials and hairline indicators are used. The condensers are either General Radio or Hammarlund. The coils are provided with individual calibration curves fitted in the removable top of the carrying case where space is also provided for the two coils. The accuracy is guaranteed at 1 per cent but should be much higher than this.

The Radio Engineering Laboratories' type A meter covers a wavelength range of 20 to 550 meters with three coils. The individual wavelengths with single coils are 20 to 80 meters, 74 to 200 meters and 200 to 550 meters. The coils are of the basket weave type wound with heavy triple covered wire. Each coil is given an extra impregnation to insure permanency. The coils are fitted with the well-known REL plug arrangement. A walnut carrying case is provided, the individual calibration curves for the three coils being mounted in the inside of the top. Space is provided in the case for carrying the additional coils. A neon tube is connected across the condenser terminals and serves as the resonance indicator. The accuracy is guaranteed to be within one per cent.

—J. M. C.

## Financial Statement

**B**Y ORDER of the Board of Directors the following statement of the income and disbursements of the American Radio Relay League for the first quarter of 1926 is published for the information of the membership.

K. B. WARNER, Secretary.

### REVENUE STATEMENT OF REVENUE AND EXPENSES FOR THE THREE MONTHS ENDED MARCH 31, 1926.

Advertising sales .....	\$19,070.26	
Newsdealer sales .....	16,404.38	
Newspaper syndicate sales .....	1,348.50	
Dues and subscriptions .....	10,717.68	
Back numbers, etc. ....	330.22	
Emblems .....	262.76	
Interest earned .....	112.81	
Cash discounts earned .....	366.13	48,612.69

Deduct:		
Returns and allowance .....	9,503.79	
Less transfer from reserve for newsdealer returns .....	1,806.94	
	7,696.85	
Discount 2% for cash .....	314.15	
Exchange and collection charges ..	26.32	8,037.32

Net Revenue ..... 40,575.37

### EXPENSES

Publication expenses .....	15,046.99
Salaries .....	12,947.48
Syndicate expenses .....	419.41
Forwarding expenses .....	709.67
Telegraph, telephone and postage ..	1,376.31
Office supplies and general ex- penses .....	2,371.04
Rent, light and heat .....	381.91
Traveling expenses .....	661.21
Depreciation, furniture and equip- ment .....	195.97
Bad debts written off .....	101.94
Communications Dept. field ex- penses .....	225.66
News Bureau field expenses .....	21.10
Total Expenses .....	34,958.69

Net Gain from Operations .. \$5,616.68

## A Two-Speed Vernier Dial

**F**OR ham receiver work we need dials having quite a high ratio if we are going to get easy tuning control, even with a very small tuning condenser and a very small regeneration condenser. The high ratio dial has one defect, though, and that lies in the fact that it takes a month of Sundays to run from one end of the tuning scale to the other when you are in a hurry.

The new Karas Micrometric dial has the high ratio and also has a direct one-to-one

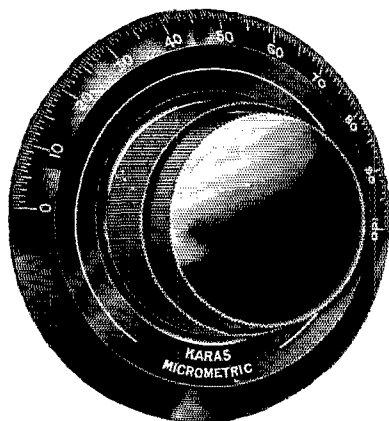

ratio whereby it is possible to instantly jump from one end of the tuning scale to the other, stopping anywhere on the road, and then sharpen up with the high ratio. The vernier mechanism consists of four gears which are cut from hard metal. By an arrangement of heavy springs and loose shafts the dial has absolutely no backlash. From the looks of the gears in the dial backlash never can develop. The high ratio is controlled by the smaller knob which is still large enough to grasp comfortably. This ratio is a 63 to 1 affair. The direct turning is accomplished by grasping the larger knob to which the condenser and dial are directly connected.

The dials are four and one-half inches in diameter and are of moulded bakelite. The numerals can be had in either right or left hand engravings. The scale is engraved directly to the half division and the marking can be had in either gold or white. A special 360-degree dial with a 0-to-200 scale is also available. A mighty nice job.

—J. M. C.

**Strays**

SBCL of Rochester, N. Y., uses his Jefferson tube rejuvenator as filament supply for a 210 in his low power transmitter.

## The Hudson Division Puts It Over

"This convention has re-established the significance of the word 'amateur' as applied to radio."—Donald McNicol, president of the Institute of Radio Engineers, at the A.R.R.L. Hudson Division banquet.

**T**HE Hudson Division of the A.R.R.L., under the able leadership of their Director, Dr. Lawrence J. Dunn, made radio history in the staging of their division convention in New York on May 13, 14 and 15. It was a huge success. It typified the best in amateur radio; it was clean and orderly; it was permeated with the A.R.R.L. spirit, and it was in keeping with the standards of the League thruout the country.

In one large respect this convention represented a new departure in amateur conventions in New York City. The fact that this was a metropolitan area with a large number of people able to attend a relatively large number of events over a three-day period made it possible to present a connected series of meetings definitely planned to form a homogeneous whole. This was particularly exemplified in the two educational or technical courses held under the direction of Mr. R. M. Pease. Of course every amateur convention ever held has had its technical meetings but at this convention there was presented a planned program on which speakers had been secured to talk on certain definite topics so as to constitute connected courses in amateur radio operation. One course was for the "already-arrived" amateurs the other for beginners who wanted to "break into the game". Many very valuable talks were given covering every important phase of amateur operation and embracing about ten hours of meetings in each course, distributed over the three days. Our chronic shortness of space in QST does not permit us to record in detail the list of speakers and their subjects. We can say tho, that it was the best job of the sort we have ever seen, including such speakers as Dr. A. Hoyt Taylor, Prof. F. S. Dellenbaugh, Glen Browning, John Reinartz, Fred Marco, Fred Schnell, Captains Rives and Autrey, in addition to the technical staff from League Headquarters. You missed a short summer college course in ham radio—you fellows who didn't attend.

Everything except the banquet was held at the United Engineering Societies Building on West 39th St. Here the manufacturer's exhibit was staged, under the direction of Mr. S. P. McMinn of 2WC. Every amateur who has attended one of the big BCL radio shows knows how he will find one or two booths out of a hundred which hold him with something of real amateur interest. This show was a col-

lection of twenty such exhibits. Without a single exception they were the sort which fascinates the amateur. These manufacturers exhibited by invitation and without charge in recognition of the support they had given amateur radio. It was a most interesting exhibition.

Now we must crowd into one brief paragraph a mention of many interesting features. There were traffic discussions, a visit to the Radio Corp transatlantic receiving room at 64 Broad St., free calibration of amateur wavemeters, a talk on the Army-Amateur Net by Capt. Rives, the Army liaison agent—and plenty of chances for hamming.

A banquet was held on the last night at the Hotel Majestic, Dr. Dunn presiding. The chief speakers were President Maxim, Mr. George Clark with his usual and well-known "line" (if he's the Will Rogers of the radio industry he has to have something to match Will's rope doesn't he?) and Treasurer Hebert. One-minute talks were also made by about twenty other visitors. First-rate music was provided by the Hudson Division Serenaders, an amateur aggregation under the leadership of Mr. B. S. Coler Southern, 2BBM.

This convention lived up to the hopes of its sponsors. It proved that the solid substantial worth-while part of amateur radio still lives, and that it lives in the metropolitan area the same as it does in every other place in the country. Congratulations and thanks are certainly due to Dr. Dunn and the hard-working crew who made up his convention committee. Bully!

—K. B. W.

## OWLS

Check your wavemeters and transmitters from these Stations

***1XM	1AWW	7ACI	8BZT
*NKF	3ZW-3BE	1ZL-1AVW	c3CO
*2WC	3AA	2OLA	9AXQ
*9KAX-9ZT	8EQ	6ZE	c4PV
*4XE	3APV	6TS-6XAG	a2CM
*4BY	5ZAV	8GZ-8ZG	e2OD
*g5LF	9DXN	9BGK	6CAE
*g5SZ	9EGU	6XAD-6ZW	5AGN
*5PH	6ZH	e2NM	9AXQ
*1AXA	5AKN-5XBH	6TI	9CPM
*8DAJ	2MU	c3NI	5EW
6XAO-6ZV	9ZA	c9AL	9BGH
6BQB	7GE-7GX	6CDN	6BX
7BU	5SP	8APZ	6BB
5MN	9EIB	2SZ	c8KA
c3FC	7GQ	7QK-7MX	1KP
z2AC	2DS	6LJ	9ECC
9FF	1BZQ	5OX	1BHW
8GU-8XC	6BGM-6CVO	9BMR	
9XI	2XI	6BCP	
1CK	9IG	1AAC-1ZO	

\*\*\* Standard Frequency Station. 1% accurate.  
\* Crystal-controlled. 1% accurate.

# Progress and Plans at 5 Meters—and Below

By Robert S. Kruse, Technical Editor

**N**OT very long ago vacuum tubes could not be made—so everyone said—to oscillate below 300 meters. That illusion delayed the coming of amateur C.W. for a while, in fact it had to be demonstrated by a few stations like

though nothing but a pair of series condensers was needed.

Since that we have begun to believe more easily—when someone talks about getting down to .77 meter we don't say he is foolish—we merely ask, "How do you do it?"

But let's not rush down to .77 meter until we have found out something about that 5-meter band of ours.

## What Has Been Done

Many tubes have been made to oscillate at 5 meters or thereabouts. At first they were receiving tubes but gradually we have learned that it isn't much of a stunt to make even a 204-A work at that wavelength. Almost any of the standard circuits will work with no change but a reduction of the L and C. Figure 1 shows a variety of circuits that have done good work at various stations down to wavelengths as low as 1.4 meters with tubes as large as 500 watters. Figure 2 shows a variety of receiving circuits, all of which seem to work rather well though the writer is inclined to prefer the Armstrong circuit. All the receiving circuits shown have the same defect anyway—the regeneration control has too much tuning effect. In Fig. 3 are shown various antenna systems, and here's a thing worth noticing. Over short ranges it seems that an antenna is very often worth less than the set alone—just using the primary oscillatory circuit as a radiator. Over long ranges this does not seem to hold.

However—I started to talk about results. As far as I am aware the longest range ever attained was between 2EB, operated by Boyd Phelps at Grasmere, Staten Island, New York, and 1XAQ, operated by the writer at Glastonbury, Connecticut. We had been testing for many weeks, Phelps transmitting at both 80 and 5 meters while I listened on both waves with a split headset. The two plate supplies at 2EB were different so that it was easy to tell which wave was being heard. The interference difficulties on these tests were terrific for 1XAQ was located on a highway and Henry Ford makes a magnificent 5-meter sending set. As Phelps says, "After a little practice one can tell the make, model and condition of spark plugs in all the cars that pass the house." The Fords with vibrator coils are the worst, the high-tension magnetos next and the A-K systems cause little trouble. Getting back to the main subject—for 5 weeks we tested without a sign

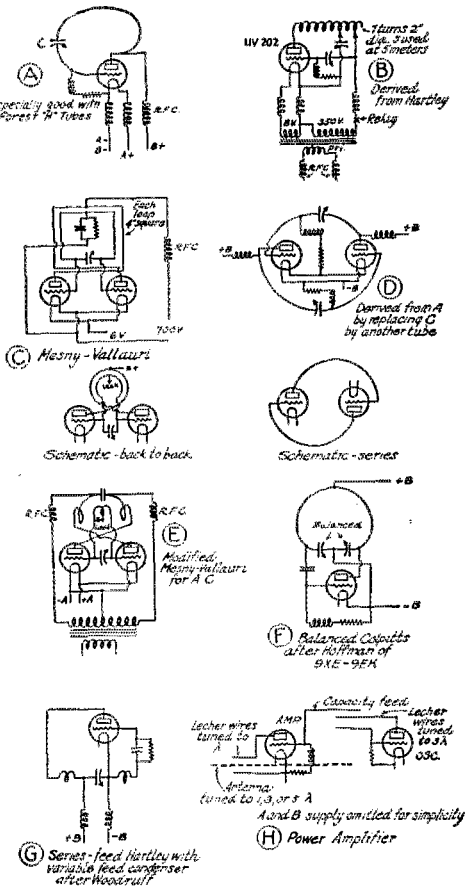

FIGURE 1 SENDING CIRCUITS

In general the condensers are chosen for low minimum capacity and special construction for this purpose is an advantage as the maximum capacity wanted is not much over 15 micromicrofarads. Inductance turns are usually about 3 inches in diameter. Above all they must be solid so as to avoid vibration.

NSF and 8BO before anyone else was willing to do so much as try 200-meter C. W. Then there was the same thing over again to get the amateur down to 80 meters,

of a result. We had calibrated wavemeters separately from Lecher wires. Checking these wavemeters against each other showed an error and the next Sunday's test started with wavemeters that checked—though not necessarily right.

**The First Real DX**

That Sunday 2EB's signal swung in briefly—very wobbly and unreadable most of the time. After a keying relay was taken off the sending base the signal was steadier but soon faded out. As the distance was some 120 miles and the tube at 2EB only a 5-watt UV-202 this was fair enough.

For several Sundays after this we tested with no results—there was rain and static in plenty. Perhaps that was the cause of failure—we don't know. Finally on the 11th test the signals of 2EB, using circuit 1B and antenna 3A, came in at excellent strength—much stronger than the 250-watt tube at 80 meters. This was at about 2 P. M. and for 20 minutes the signals were splendid. Then a fog rolled up from New York harbor and as it rose over Staten Is-

may be caused by a variety of things, amongst which, the strongest probability is that we have made the error of operating the sending antenna indoors although results were poor at the former locations un-

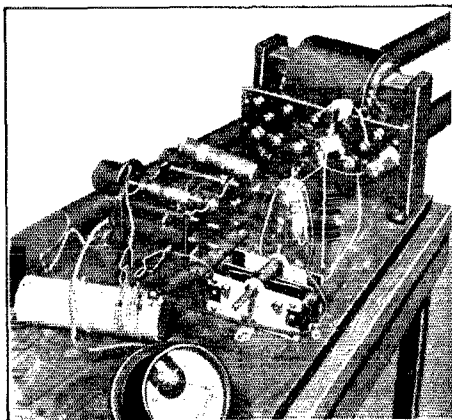

**THE TRANSMITTER AT 2EB WHICH DID THE 120 MILE WORK.**

This was coupled to the antenna shown in one of the line drawings. The antenna current was 2 amperes with a tube input of 16 watts. The circuit is shown in one of the figures.

til outdoor antennas were used. This again may be a rule or a coincidence—we don't know as yet. Tests are being continued.

**S.S.M.'S Fine Work**

6T5, 6CNC and several other west coast stations have operated at waves between 1 and 5 meters covering distances that ran up to 20 miles or so. 9ZT, 8GZ and quite a few others have run perfectly good sending sets over many hours with no results. Just when one begins to get discouraged by such reports there turns up something that is worth-while, such as the two contacts between 2EB and 1XAQ—even though the return transmission in that case was at 80 meters. More recently Marcel Saces of 50 Avenue Albert, Castares, France, has done some very beautiful work at wavelengths below 5 meters. Unfortunately his story cannot be reported in full here. Briefly—using the transmitting circuit of Fig. 1C he has at wavelengths of 4.3 meters obtained reception over distances as large as 600 kilometers in both daylight and darkness, automatic recording at high speed being possible. Telephony was possible for about 200 meters, using Heising modulation. Reception with a super-regenerator as shown in Fig. 4 was possible at 20 kilometers with no antenna at either end.

The power used in these tests is unfor-

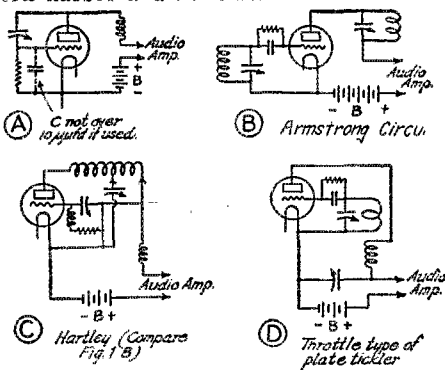

**RECEIVING CIRCUITS** Note—All grid leaks variable

**FIGURE 2 RECEIVING CIRCUITS.**

Dimensions for these can be found in past files of QST. A general rule is to use inductances and capacities much like those recommended for the transmitters.

land the signal wavered—and went. It has not been back though many tests have been run since from locations not greatly different, though less favorable.

**Possible Explanations**

The weather maps show that in all of our tests we had just two really fair days—and those were the two on which signals came through. This may be a coincidence—or it may be the explanation. Certainly it is a comment on the east coast climate for there were over 40 tests.

The total failure at the new locations

tunately not known but it does not matter greatly, the chances of using tubes of more than 1 kilowatt rating are not very good—although that statement will probably have to be corrected in a few months.

**The Theory and the Practice**

Our skip-distance theories predict that 5-meter signals will not be good except (just possibly) at very great distances—10,000 miles or so. Many tests have failed entirely to show any signals at moderate distances. On the other hand we have such results as the beautiful work of French 8SM just mentioned and the two contacts between 2EB and 1XAQ. Are these accidents? Our work might have been but that of 8SM seems to have been consistent.

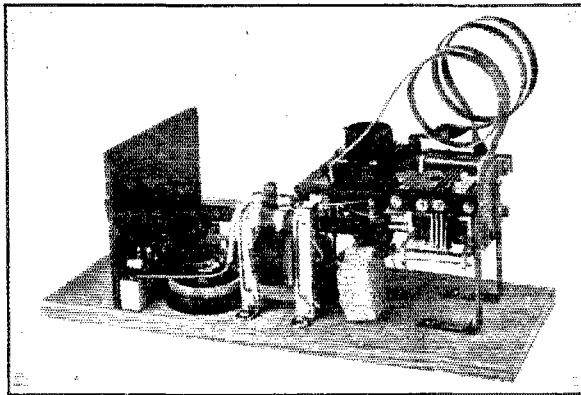

A 5-METER RECEIVER BUILT BY EUGENE C. WOODRUFF, DIRECTOR ATLANTIC DIVISION A.R.R.L.  
This set uses the series-feed Hartley circuit with a variable feed condenser to control the tuning.

One then begins to wonder—are our theories actually correct at 1 to 5 meters? The best way to answer that is to make tests until we know whether 5 meters is good for anything at all—and if so for what distances. Then we will have confirmed the theory, or made its revision necessary. It really does not matter which result we get, the work will be worth while.

To get a little more light as to the behaviour of signals as they leave the transmitter a radio exploration car has been financed by Boyd Phelps and the construction on it done by him, Arthur Zavarella of 10A and by the writer. The equipment of this "radio flivver" enables it to carry a short-wave receiver (5 meter, that is), a long wave receiver (40 meter) and a pair of transmitters working from D.C. at wavelengths of 5 and 160 meters respectively. With this, and with the cars of the writer and Phelps, much prowling around has been done near the two stations—that is, 10A

and 2EB. The "radio flivver" (known as "Conny" because it bears licenses from Connecticut and New York) operates under the calls of IBAO and 1HX, usually sending C.W. at 160 meters. Rather uniformly the signals from the 5-watt set at 2EB seem to have good strength at distances varying from 7 to 15 miles, beyond which little has been done. This does NOT mean that the signals do not carry further— simply that we wanted to find out what happened near the station before going further afield. One curious angle on the thing at 10A has been that the power at the station does not seem to have a very great effect on the signal strength except right at the station. It is quite likely that this is an error as no audibility meter was used.

Much more of this mobile reception needs to be done and the radio flivver will be busy this next month— though possibly nothing useful will be found.

In general the writer feels that the theory is to be trusted just one step beyond our known territory—but not two steps. We are reasonably sure of the things that happen at 20 meters, we know a moderate amount about results down as far as 12 meters—we know practically nothing about 5 meters. The next thing that we do really know is that wavelengths a few microns long do not act at all the way our 12-meter waves acted. Somewhere in between a change took place. Was it at 5 meters—3-1 or 1/100? We do not know. We suspect it was NOT at 5 meters and that this wave

will not be especially useful, but it is quite as likely that we are wrong and

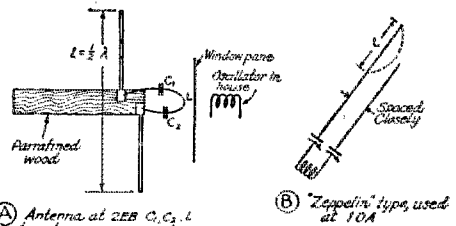

(A) Antenna at 2EB C<sub>1</sub>, C<sub>2</sub>, L tune to same wave as antenna, therefore do not load it.

(B) "Zeppeini" type, used at 10A

ANTENNAS—note All may be used with reflectors

FIGURE 3 ANTENNA SYSTEMS  
In each drawing the dimension L should be equal to 1/2 wavelength. Where L is not shown this rule fails.

that 5 meters will have possibilities. In any case— work at 5 meters is excellent preparation for work at "sub-one" meter—and somewhere down there we will find new and useful laws of transmission.

**Organized Effort**

To get ahead faster, to make some more extensive progress on such basis as the 8SM and 2EB work, organized work is necessary. The writer therefore passes on to QST's readers the suggestion of Mr. Phelps that we plan an "International 5-Meter Week," taking enough time to it so that we may get replies to the suggestion from the remote points that seem to offer the best chance of results.

We have run such tests before inside the United States but even if the distances had been right it is very doubtful if the tests were planned carefully enough or carried out. For the present therefore I offer the suggestion that we count on some international tests during August or September—thereby giving everyone ample time to get a sender and receiver into operation. Senders with a fair amount of antenna power (100 watts at least) are especially needed—and in particular in countries other than those on the North American continent.

Naturally good attention to tuning is required and all concerned should make very sure that their wavelength standards are somewhere near right. It may be advisable to scatter the sending waves somewhat, for instance using 4, 5, 6 and 7.5 meters; grouping the stations and shifting stations from group to group at various times. All this can be better determined when letters from American and foreign stations begin to arrive.

**Information Wanted**

The information needed from both American and Foreign stations is about as follows:—

Wavelength range over which the receiver will operate.

Wavelength range and power of the transmitter.

Times at which (Greenwich time) it will be possible to operate. Please do not limit this too closely as some inconvenience will be necessary.

Please do not depend on our information as to your address or call, please PRINT your name, call, and full address on the letter. Too many of us in radio seem to write in a way that only we can read.

**Conclusion**

In writing such a brief account as this it has been necessary to slur much fine work to save space. The writer therefore apologizes to the men so overlooked, and refers the reader to the past files of QST where much of this work is fully described as it deserves. Radio has also carried some articles about the very nice "sub-one" meter work done by California experimenters—

in fact some of the circuits here shown are taken from that work, though simplified for understandability. These references also will provide the credit lines and the dimensions of coils and condensers, things for which the present paper has too little space. The methods that have been described are

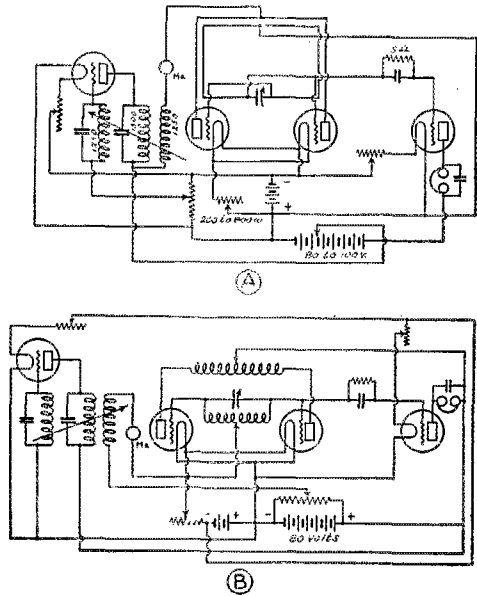

FIGURE 4. SUPER REGENERATIVE RECEIVERS USED AT F8SM

A—Plate variation method. The tube at the left is operated at audio frequency—or nearly so. The coils are honeycombs with the number of turns marked. The two tubes at the center are oscillating at the working wave in a Mesny circuit. The tube at the right is a detector.

B—Grid-voltage variation method. Otherwise the same as A.

perhaps the best—and perhaps capable of much improvement. It will be well not to follow the drawings and articles too faithfully in working up a sending set or a receiver. The antennas in particular leave room for much work in this connection useful suggestions may perhaps be found in the article in this issue entitled "Feeding the Antenna," in which the writer has attempted to put together the various methods used by amateurs and commercial stations today.

**Strays**

A good way to do away with CQ. Send "C" followed by your own intermediate. A CQ from a Brazilian station would be CBZ CBZ CBZ BZ 1—, or a British CQ would be CG CG CG G 2LZ. A fine suggestion, too. It's from Paddon of 2FU.

## Experimenters' Section Report

**A**S was promised last month the report this time will include the various items we were compelled to omit in favor of the description of the South Schenectady Experimental Radio Transmitter Plant.

### Enrollment

Enrollment of this section continues at an even rate. At the moment the number enrolled is slightly higher than at any time passed. The outlines are reasonably well up to date and in general the "X" Section seems to be making some definite progress, thanks mainly to the efforts of Messrs. Westman and Flebeau.

Enrollment, as before, calls for no special requirements. If you are interested, send in your name and we will send the list of problems from which you are welcome to choose the particular ones that are of interest to you. The manner of working at these problems is then mainly up to you—we are mainly hoping to help you along with outlines, suggestions, the Information Service and the membership lists which let you get into touch with others working on the same problems. Naturally *QST* wants to hear of the results when you think they are of *QST* interest.

### Where We Are Headed

There has been an increasing number of inquiries along the line—Where is experimental radio headed? Where is radio engineering headed? How does it happen that so often several men seem to invent the same thing at the same time? In the following words Dr. E. F. W. Alexanderson answers these questions and at the same time gives radio a place in relation to other engineering.

### The Future of the Radio Inventor

By E. F. W. Alexanderson\*

**A**MONG all the technical arts, Radio has given the greatest opportunity to the inventor. Each branch of the engineering art has had its own eminent specialist who has created most of the new things that have been done in that art, but radio has become a playground for all. It seems to be the favorite child of all the other technical arts and sciences, a meeting ground for the exchange of mutual inspiration.

A new field of human endeavor has now

been created, the originators were the most advanced thinkers in physical science and electrical engineering but the most significant fact is the unprecedented rapidity with which this new knowledge has spread. In the now growing generation almost every high-school boy has, thanks to the popularity of radio some intimate knowledge of a complicated art which not long ago could be grasped only by a very few.

As our civilization marches forward it makes inventions with an inevitable necessity. Inventors by habit and profession are simply the scouts who march ahead and become aware of new technical developments somewhat ahead of the multitude. A new event is usually seen by several of these scouts at nearly the same time, but these scouts are becoming more and more specialized and they are able to discern new phenomena only within the limited sphere in which they have been trained. The necessary training is in most cases an opportunity which has come to only a few among the many who might have accomplished the same.

If we should project into the future the growth of the electrical arts and sciences we can see the young art of radio growing up and taking a central position. We think of radio now as a useful system of communication and a delightful form of entertainment but its greatest significance in the future will be its educational influence. Radio will be the school of training which will educate the engineers, inventors and scientists of tomorrow; not by the thousands but by the millions. If you will let loose your imagination what may you not expect from generations so trained? The future great discoveries regarding the nature of matter, energy and the universe will be made by those who have as boys been playing with electrons and probing the lengths and depths of space by radio waves.

The forces of nature will be harnessed on a scale not yet imagined in the form of electricity made into an indispensable servant in every village and farm but the engineers who invent, plan and operate this new development will all be trained in the school of radio. They will all speak the same technical language and their imaginations will follow out the thoughts which were started in their early training.

Creative thought is passed along by personal contact and the radio fraternity is today the forum where science, engineering and industry can meet on a common ground."

\* Consulting Engineer General Electric Co., Chief Consulting Engineer Radio Corporation of America.



### 5-Meter Tests

In this issue of *QST*, page 34 there is a "story" about the methods of 5-meter work. It is the intention to do some more field testing, the tests to be announced through *QST* if there is time, otherwise through bulletins to the members of this section.

At this time, theory and practice are in only partial agreement. This is possibly because there is so little of the practice to base the theory on. Frankly—5-meter tests will probably show the relative uselessness of such a wavelength for distances such as amateur radio ordinarily wishes to cover—but it will help to understand the whole thing if we have some evidence as to the points at which signals can be made to come down. At present our evidence is very small indeed—a little work by a few European stations—even less by American stations. With the exception of two stations none have done anything that is encouraging—but those two have managed to reach over respectable distances.

Will all those willing to send or listen on a 5-meter test please write to Experimenter's Section, American Radio Relay League giving some indication as to the possible transmitting power (which should be at least 50 watts in the antenna) and the wavelength standard used. It does not matter for this purpose whether one is enrolled in a transmission problem or not.

### Foreign Members — Attention!

Because the chances are so good that 5-meter signals will work only at a great distance it is especially desirable to have the co-operation of men in other countries—especially New Zealand and Australia. Co-operation from these countries will be especially welcome. There will be at least 6 reasonably dependable 5-meter stations in the United States with antenna powers of 200 watts or more.

### The L/C Ratio

The Technical Editor's desk has lately been crossed by increasing correspondence regarding the correct L/C ratio in the input circuits of receiving tubes. In general the writers seem to feel that the general practice in this matter is quite as likely to be wrong as right. The writer is inclined to be of the same opinion. Does anyone know of any worth-while results to show that we are actually right in sticking to high ratio of L/C where the regeneration is controllable? The results need not necessarily have been gotten with complicated means—just so they are carefully done. Advice will be greatly appreciated.

### References

Members of this section have called at-

tention to the following articles as likely to be of general interest:—

Screening and Tuning Coil Efficiency, J. H. Reyner, *Wireless Weekly*, February 3, 1926.

Also the following three papers, all of which appear in the April issue of *Experimental Wireless & the Wireless Engineer*:  
The Mystery of Fading, Oliver Hall, p. 211.

The Directional Recording of Atmospherics, R. A. Watson Watt, p. 234.

An Experimenter's Wireless Laboratory, Sayce & Taylor, p. 243.

### Field Strength Measurements

In a very interesting letter which unfortunately cannot be printed in full Dean R. W. Goddard of the School of Engineering of the New Mexico College of Agriculture and Mechanic Arts makes some very practical suggestions with regard to field-strength measurements when using a loop as described in a previous X-section report under the heading "Turnbull's Field Strength Set."

One of these suggestions is to use a Weston model 375 galvanometer as the indicator. The instrument has a 30-0-30 scale. The scheme is to adjust matters to secure a deflection to 30 left, then cut off the current and set the hairspring adjustments so as to secure a normal position of 30 right. Then when the tube is turned on we have a zero reading and readings due to incoming signal are "up the scale."

A more sensitive set for use at greater distances was obtained by using a portable superheterodyne receiver, Radiola model 24, with a Weston model 375 galvanometer as before. In this case the meter has a 0-60 scale and is shunted (noninductively) so that the normal plate current of the last tube gives a half-scale deflection. The hairsprings are adjusted as before to bring the needle back to 0. Then whenever the set is turned on the needle should stand at 0, or something is wrong and needs attention. The adjustments of A-, B- and C-voltage made the first time are so chosen that incoming signals cause increased output currents—audio quality being no object here.

Another convenient indicator is a combination of an audio transformer (fed from the set), supplying a Weston galvanometer as before—but this time through a UX-199 tube used as a rectifier, with plate and grid tied together. Calibration curves are made by comparing the readings of this indicator with those of the previous indicator when receiving signals of various strengths. These signals can be obtained conveniently from a small C.W. set modulated by the output of an audio oscillator.

### Omission from 1XM Description

A most unfortunate error occurred in the publication last month of Mr. Lansingh's article "A.R.R.L. Standard Frequency Station 1XM". A portion of the text and two illustrations were omitted. For this mistake we wish to apologize, in particular to Mr. Lansingh and the staff of 1XM. Here's what we left out—it should have followed page 47.—Editor.

#### Co-operation with Other O. W. L. S.

When other stations request measurement of their frequency the small station frequency meter is used; crystal-controlled stations which are also OWLS<sup>1</sup> (and will agree to sign off their frequency regularly when operating) may make arrangements by mail with us to have their frequency measured directly against the

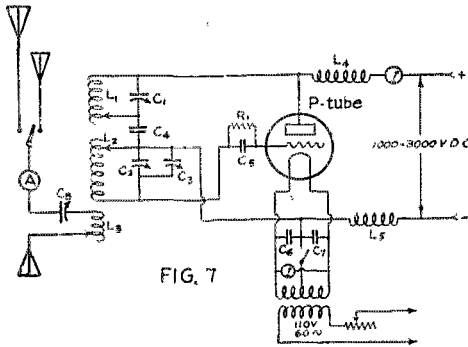

FIG. 7

CIRCUIT OF STANDARD FREQUENCY TRANSMITTER AT 1XM

- L1—12 turns copper tubing, wound to 3" diameter
- L2—17 turns copper tubing, wound to 3" diameter
- L3—15 turns No. 8 copper wire wound to 3" diameter
- L4, L5—Radio frequency chokes
- C1, C2, C3—250. µfd.  $\frac{3}{8}$ " spacing condensers especially built by National Company
- C4—2000. µfd. Paradon fixed Condenser, 6000 v.
- C5—250. µfd. "double spaced" National Condenser

Standard Frequency meter. About half or three quarters of an hour before the beginning of a Standard Frequency schedule will be most convenient.

#### Station Wiring

Among the number of convenient arrangements is a plug and jack-system for the batteries. A plug on each battery may be plugged into jacks leading to the various receivers and other apparatus in the station, or to the charging panel. 4-, 6-, and 12-volt batteries are available. Toggle switches at both operating positions control both filament and plate powers for both transmitters, the main switches only being used when the station is closed up, and when

work is being done near leads which may accidentally get mixed up with the high voltage. A small solenoid attached to the mercury arc holder may be activated by

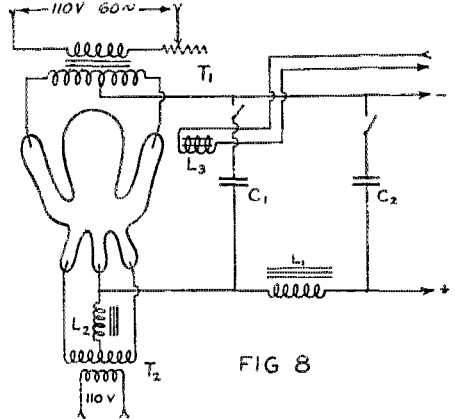

FIG. 8

CIRCUIT OF MERCURY-ARC RECTIFIER AND FILTER

- T1—Transformer, 1000 v. to 7000 v. secondary
- T2—Transformer, 220 v. secondary
- L1—Choke, 50 henrys
- L2—Choke, 25 henrys
- C1, C2—10 µfd each
- L3—Solenoid for shaking arc.

closing a switch near the Standard Frequency transmitter, thus shaking the arc to start it, or to shake down the mercury which condenses on the sides of the arc tube.

(Concluded on Page 46)

<sup>1</sup> O.W.L.S. stands for "A. R. R. L. Official Wave-Length Station." The system of OWLS was an outgrowth of the Experimenter's Section and of the demand for the transmission of known waves shorter than those of WWV and 6XBM. The OWLS network was planned in a conference at the University of Minnesota with Messrs. Jansky, Wallace, Hebert and Kruse present. Contrary to general impressions, the OWLS are not radio policemen and not a Communications Department activity; in fact the work is mainly not done from Hartford at all. The reason for this is that the writer of this note felt sure that the best operation of the scheme would be forthcoming under the leadership of a strong and centrally located station. There was accordingly created the OWLS Committee, consisting of Don C. Wallace as chairman and Prof. C. M. Jansky, Jr., Director of the Dakota division, as advisor. This gave the requisite control thru Prof. Jansky to the standards of 9XI at Minnesota University.

The OWLS committee has lately been increased by the addition of Mr. K. V. R. Lansingh, writer of the article to which this note is attached. Mr. Lansingh is in charge of A. R. R. L. Standard Frequency transmissions. He hopes to add other stations to give service similar to that of 1XM at other parts of the country.

This will take time, for stations willing to undertake the great labor involved are very scarce.

The methods of the OWLS are given elsewhere in this issue together with the next schedules of 1XM. —Tech. Ed.

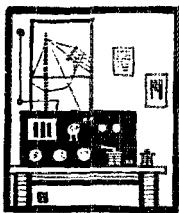

# Amateur Radio Stations

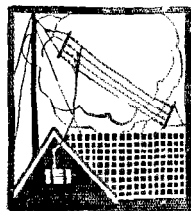

## IAOF, Greenfield, Mass.

**T**HIS station is the result of another B.C.L. having gone wrong. About a year and a half ago, H. C. Wing, the owner and op at 1AOF, decided that he had monkeyed with all the broadcast receivers and receiving circuits there were and took it upon himself to feel around, and plunge into amateur transmission. After learning the code he was assigned 1AOF as a call and then started a long series of short-wave transmitting and receiving experiments with the beautiful results shown in the photographs.

All of the woodwork in the transmitter is of Honduras mahogany, impregnated with paraffine after being dried and seasoned thoroughly. The transmitter uses a single 204-A tube in a coupled Hartley circuit. After many experiments with flat- and edgewise-wound inductances, copper tubing, etc. it was found that the pancakes gave better antenna current, sharper tuning, allowed looser coupling and caused much less local interference. As will be seen in the photo, the inductances are mounted high

to get a good start and hit the Heaviside Layer with such a bang that they will fall back in as many places as possible. All R. F. leads in the transmitter are of 5/16

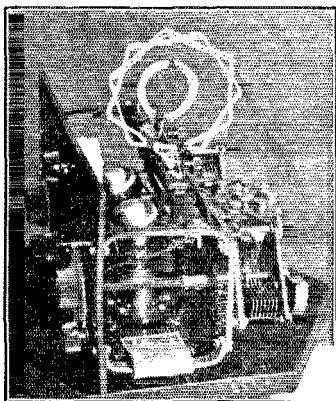

THE RECEIVER AT 1AOF

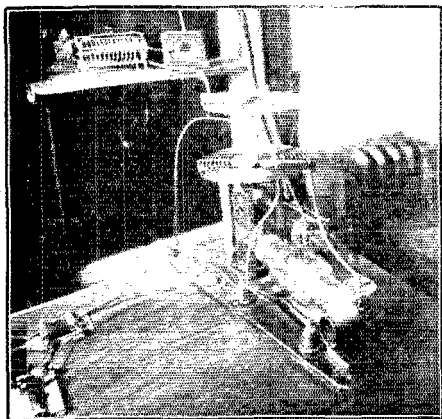

THE TRANSMITTER AT 1AOF

and clear of everything else, thus minimizing the losses due to fields straying around. The antenna inductance points straight up toward heaven, giving the signals a chance

inch copper tubing. The grid leak and grid condenser are mounted vertically in order to shorten the length of the leads. The R. F. leads and apparatus make contact only with G-R porcelain standoff insulators. Various plate supplies have been tried. These include raw A.C., chemical rectified A.C., and "S" tube rectification but DC from an Esco 2,000-volt 1,000-watt motor-generator with plenty of filter has proven to be most satisfactory. Practically all reports are pure D.C. and many fellows rave about the pure whistling note from the storage battery!

Wing says that he has tried about a hundred antenna-counterpoise combinations and has ruined over a thousand feet of No. 12 wire until he hit upon a single No. 12 wire 32 feet long, suspended almost vertically. A single wire 28 feet long running down toward the ground at a 45 degree angle comprises the counterpoise. Lead-ins are Pyrex bowls and 12" insulators of the same materials are used in the antenna and counterpoise.

The other photograph shows one of the many receivers which have been built and torn down. We wish that the photograph was better. It doesn't do the beautiful job

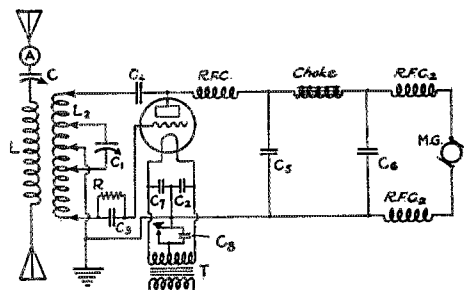

- C—National 100-μfd.  $\frac{3}{8}$  inch spacing  
 C1—ditto 450-μfd.  
 C2—2,000-μfd. Dubilier receiving condenser  
 C3—2,000-μfd. Faradon 7,500-volt condenser  
 C4—25-μfd. Faradon 10,000-volt sulphur condenser  
 C5-C6—Tobe 2-μfd. 2,000-volt condensers  
 C7—same as C2  
 C8—25-μfd. 1,800 volt keying condenser  
 L—6 turns  $\frac{3}{8}$  x 1 16 inch copper strip, 10 inches in diameter  
 L1—8 turns ditto 11 inches in diameter  
 RFC1—80 turns No. 26 DSC on 2 inch tube  
 RFC2—30 turns No. 18 DSC on 3 inch tube  
 Choke—30-henry Acme  
 T—100-watt Acme filament heating transformer  
 R—5,000-ohm grid leak  
 MG—Esco 2,000-volt 1,000-watt M.G.

anywhere near justice. The receiver is built on and around a 7 x 12 hard rubber panel. Insulation is entirely hard rubber and air throughout the set. The tube sockets are mounted on a small sub-panel supported at each end by soft rubber strips which eliminate any microphonics. The variable condensers are mounted on a sub-panel five inches from the front panel, and are cranked by long rubber shafts extending to the vernier dials on the main panel. The coils are mounted well out of the field of the other apparatus, and are supported by a narrow hard rubber strip. The present coils are wound with number 12 enamel wire a La 6HM in March QST.

The station is equipped with a very accurate direct-reading wavemeter having a range of 10 to 50 meters. This meter was calibrated at the Cruft Laboratory at Harvard. A G-R type 174 wavemeter with a 75 to 1,500 meter range is also used. All incoming signals are checked with an audibility meter as well as the wavemeter, so reports from 1AOF are accurate and reliable. During the past winter 1AOF has worked and been heard in almost all countries where there is a short wave receiver or transmitter. His best DX is to a5BG and has many consistent reports from all over Europe and South Africa.

## 60I, Stanford University, California

NOT many months ago we ran a description of 60I. We are showing this station again because the previous photo was N.G. and because the station has been entirely rebuilt. 60I needs little or no introduction. The station is jointly oper-

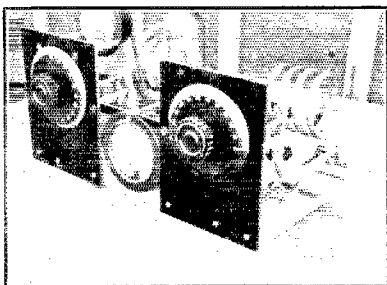

THE LATEST AT 60I A 20-METER 50-WATTER

ated by Wentworth and Scofield, most of the construction being done by Scofield.

The transmitter circuits are tuned grid and tuned plate. The set is not of the experimental variety, 60I having previously gone through all of the experimental work

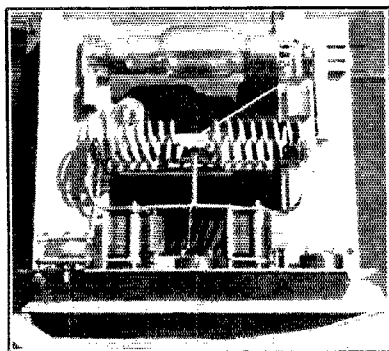

THE 250-WATT 40-METER TRANSMITTER

necessary to convince the owners that the set in use now is sufficiently flexible for any and all traffic handling. The only adjustments to be made in the set are the tuning of antenna, grid and plate circuits. The coupling in all cases is fixed. The plate and grid inductances are made of five-sixteenths inch copper tubing, the turns being spaced and self-supporting. Each inductance is

mounted on a G-R porcelain stand-off insulator. Twenty meter grid and plate coils have four turns and forty meter inductances are made of eight turns. In both cases the outside diameters are three inches. The coils can be changed in a minute. Plate and grid tuning condensers are rebuilt De Forest receiving condensers with one eighth inch spacing. The plate condenser does not spark over even when a plate voltage of 3,300 RMS is used. The antenna coupling coil has two turns of copper tubing, mounted over the plate coil. A general Radio 350- $\mu$ fd. receiving condenser is used as an antenna series condenser. Plate supply is obtained from a two-KVA pole transformer. A high voltage synchronous rectifier is used to iron out the A. C.

The old 50 watter formerly used for 40-meter work has been built into a 20-meter transmitter similar to the 40-meter 250-watt set. In the case of the 20-meter set, ordinary receiving condensers are used in antenna, grid and plate circuits. The inductances are similar to those in the larger set. On 20 meters 6OI has been doing some splendid work lately, having successfully worked ch9TC in broad daylight on a number of consecutive days. KEGK has also been communicated with on 20 meters, and of course many stations closer to 6OI. The most excellent results at this station are due to a good location, good transmitters and excellent operation.

## a5BG, Clarence Park, South Australia

**T**HIS is an internationally known station, and is the product of H. A. Kauper. A number of transmitters are in use. The latest, and one of the most interesting, is a low power affair using a 201-A with inputs ranging from 5.2 to 7.5 watts. On 84 meters this little set has been QSO the U. S. fourteen times within the space of a few

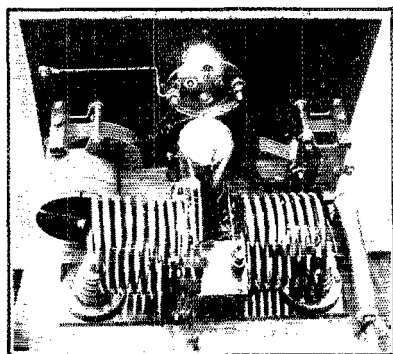

THE a5BG LOW-POWER TRANSMITTER

nights. The circuit is the split series-feed Hartley. The inductances in grid and plate consist of 8 and 10 turns, respectively, of quarter-inch copper tubing wound to a diameter of 3 inches, and supported on porcelain stand-off insulators. The grid and plate tuning condensers are 250- $\mu$ fd. receiving condensers and the B-battery bypass is a homemade 100- $\mu$ fd. foil and mica condenser. A 0-500 M.A. Weston thermammeter is used in the antenna circuit and a 0-100 milliampere meter is in the plate circuit. The grid leak (at the right of the photo) is a 15,000 ohm non-inductive re-

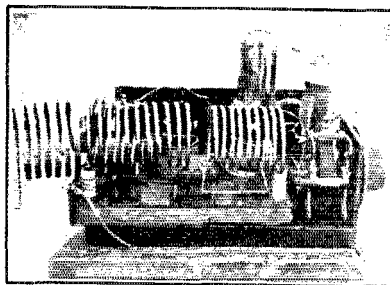

THE a5BG 50-WATT TRANSMITTER

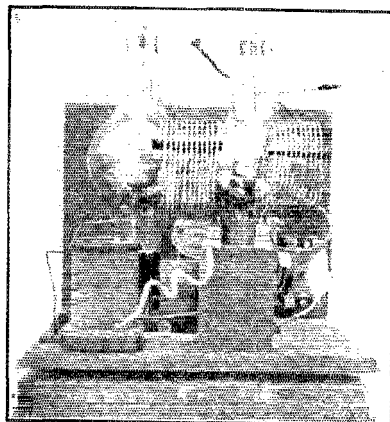

THE a5BG 1-K.W. TRANSMITTER

istance. The antenna coil is wound over the plate and consists of four turns of number 12 wire space-wound and supported by

*(Concluded on Page 46)*

# Calls Heard



11T, 49 Atherton Street,  
Jamaica Plain, Boston, Mass.  
40-Meter Band

a2yi b12 b4yz bzlab bzlac bz2ab bz5ab c5go c8ar  
c8wm ch2ld ch3ij d7bz eear23 eear6 f8ca f8ct f8dk  
f8ee f8gi f8gra f8hm f8ix f8jf f8jw f8rbp f8zo  
g2ec g2nb g2nm g2sz g5dh g5gs g5hs g5ls g5mq  
g5nn g5pz g5sz g6al g6kk g6ox hu6buic ilas iler  
ilgw ilno ky8 mij oa4z piaa p8 co q8kp sscg z1aa  
z1ao z2ac z2cs hik (qra?) kio npm ocng rxxd (qra?)  
wvy. pse.qsl.

Chas. P. Weaver, 1374 Overbacker,  
Louisville, Kentucky.

a2bk a2cs a2yi a3ef a3xo a5cn a7hl b4qq bzlaw  
bz2sp bz5ab c1dj c2do c3hf c3by c3ck c3kt c4ac  
c4de c4dw c4gt c5go ch2ld ch3ij ch9tc f3bp f8ca  
f8gi f8hm f8jw f8rbp f8vaa f8yor g2od g2sz g6qb  
hu6axw hu6buic hu6oa hu6tq hufxl ilgw ilno mljmin  
m9a mjh p2pt p5eb p5pt pilcw pr4ja pr 4rx rfgl  
ssdk sscg z1ak z1ao z2ac z2ae z2aa z3af z3ai z4aa  
z4ac z4ar zkfw zkgk kio naj nar narl nem nidk nkf  
nfh npa npg npl npm npp npq npu ntt xam xda ido  
fw.

4DK, M. I. Hull, 432 North Montgomery St.,  
Memphis, Tenn.

a2cs a2yi a3ef a3ra bzlab bzlac bz1ae bzlan bzlap  
bz1aw bz1ib bz3al bz5ab c2cg c3ad c3gg c3mf  
c3zb c4dw c5go ch2ld ch2alg g2nq \*hu6clj\* ilgw  
mlj mlk m9a oa3b oa3ba oa3e oa4v oa4va pr4ja  
pr4je pr4rx q2mk z1ac fw nve huwji beber nis xda  
nkf cnrt nism.

60F-6DAC, 752 Arlington Avenue, R. F. D. 3,  
Riverside, California.

las laao lahb laiv laki laid lbhd lbfz lbqt lca1  
lcaw lij lrp lqm lvy lxx 2acs 2afo 2als 2aky 2akp  
2apv 2atk 2aad 2bc 2caz 2cpa 2cuu 2czl 2ef 2ha 2jn  
2kg 2jv 2px 2rm 2xc 2zv 3aib 3auv 3ais 3bet 3cc  
3cpa 3cju 3fy 3mk 3mv 3py 3zo 4da 4fj 4f 4ft 4gt  
4hn 4in 4mi 4oa 4xe 8ax 8ajn 8aly 8alr 8alo 8aul  
8arq 8awq 8atz 8avx 8bau 8blo 8h1b 8hnb 8bgn 8byu  
8byn 8bze 8cc 8can 8ccf 8cfn 8cug 8cph 8cjm 8cme  
8dia 8djp 8dmz 8dpm 8dse 8don 8ddl 8eb 8ex 8hw 8nt  
8se 8sv 8vt 8xe a2cm a2cg a2ij a2lk a2rc a2tm a2yi  
a3ai a3bd a3bt a3nc a3qh a3wm a4rb a5kn a7dx.  
c1ar c2be c3oy c3mv c3ni c4af c4ah c4cb c4cb c4dq  
c4dy c4gt c5am c5ef c5go c5gc c5re c5bi, ch 2ar ch2ld  
ch8ag ch3ij ch9tc, cgh hu6clj hufxl hu6hd l3vn  
l1kk l1sk mlj mlk mln mjh pilau pilhk pilhr  
picd8 z1aa z1ao z2al z2ac z2ak z2bx z2ga z2ge z3af  
z3al z4aa z4ac z4ak z4am.

6AQV, S. J. Feliz, 1068 Second Street, Santa Rosa,  
California.

ch2ar ch2ld ch3ij ch9tc f8ff oa6n c3aj c3by c3mv  
rafl reb8 rdb2 mlh mlj m9a pilhr picd8 a2bk a2cs  
z1ao z2xa z2ac z4as z4am qlaoa najd nzm npo npu  
wvc wvz kfuh.

6ASD, 2347 Lucerne Avenue, Los Angeles, Calif.

u-lahc lair laiv laiw lapv laxd lbhs lbxz lcaw  
lcmx leri lde lhn lvc lwl lyd 2acs 2ahm 2akb 2aiu  
2anv 2bur 2cc 2cu 2cxl 2czr 2efe 2kg 2ku 2kx 2mu  
2uc 2wr 2xaf 2xc 2ha 2aal 2adb 2agf 2aiz 2av 2bcn  
3cc 3ekj 3fy 3ld 3ll 3mk 3wf 4aab 4ac 4ab 4bu 4cu  
4er 4fj 4fv 4lk 4ll 4oa 4rm 4sa 4vq 4wb 4ada  
4agb 4ahh 4ahk 4aia 4aju 4aub 4bau 4bds 4h1b 4hzt  
4scu 4ebd 4-h1 4ccm 4ckk 4cib 4cme 4cjm 4ctk 4cty  
4cvg 4dai 4dno 4gz 4kc 4kf 4kw 4se 4si 4xe 4zu a2bb  
a2bk a2cg a2cm a2cs a2mh a2rc a2ss a2tm a2yi  
a3ad a3aq a3cm a3kb a3lm a3px a3qh a3tm a3wm  
a4ad a4an a4rb a5kn a5lf a7al a7aw a7dx au7jo auwxp  
bzlab bz1ac c3mv c3qs c4ald c4bz c4eb c4dq c4dw  
c5am c5ef c5go c5gw ch2ak ch2ar ch2ld ch3ij ch9tc

ffw hu6ar hu6axw hu6dbl hu6def hu6oa hufxl mlk  
m9a mjh pilar pilhr pi3aa pic08 pi neqq pinpo pr4rx  
q8kp rdb2 z1aa z1ao z1fq z2ac z2ae z2bx \*z2gc z2xa  
z3ac z3af z3aj z3am z4ac z4ak z4am z4ar z4xa aaq  
kfuh lv naj nar naw nba nin nivq wvc xda.

6DDN, 1344 Bernal Avenue,  
Burlingame, California.

1ao ladm lakz lbrf lbq lga lku lts zah zai zamj  
2ati 2aut 2awq 2bun 2bur 2buy 2by 2coq 2cql 2cxl  
2fm 2fr 2ha 2ir 2kg 2ld 2nf 2px 2qz 2wc 3by 3ea  
3ni 3nf 3ll 3wf 4al 4am 4bk 4ec 4fa 4fx 4hr 4pu 4pf  
4tz 4za 5aab 5adx 5aij 5ajj 5am 5amc 5amn 5apm  
5atv 5asv 5bn 5dd 5dl 5dq 5ea 5eb 5fl 5gw 5ha 5hl  
5iz 5jr 5kx 5ld 5lm 5ng 5qs 5ux 5rg 5sb 5uk 5vm 5yb  
5za 5adh 5ajn 5alf 5aly 5ary 5cfl 5cn 5cy 5cor  
5dpx 5kv 5pl 5rh 5yl 9aay 9adi 9ads 9alf 9bca 9cdv  
9cf 9j9 9la 9lk 9mn 9nm 9ph 9wo 9xi 9zd 9zt mlaa  
mij mlk m9a pi-lhr.

7NH, Paul J. Globensky, 710 5th Avenue,  
Hoquiam, Washington.

lads lahv laxa lbaa lbie lbfl lboa lcmx lcow  
2agi 2mj 2cxl 2ha 2iz 2kg 2me 2nw 2nz 3aan 3ade  
3adv 3buw 3cju 3ly 4bu 4cu 4fa 4ft 4kx 5aav 5aij  
5hn 5jf 5ql 5aju 5aly 5arg 5aul 5ban 5bjg 5bpl 5cwt  
5dgy 5dnu 5doi 5jq 5kw 5qb 5ag 5aw 5ads 5aed  
5ael 5aux 5be 5bz 5bf 5br 5bnf 5cn 5cc 5cet  
5ckb 5cmn 5cn 5cpk 5ctg 5cv 5cve 5evn 5eyv 5dbw  
5dq 5dkc 5dnx 5dpm 5dqj 5dqz 5drz 5eg 5ek 5ekf  
5ekt 5oo 5oy 5ad 5uu 5xi c3fe c3zb hu6adh hu6af5  
hu6asr hu6axw hu6buic hu6clj hufxl a2bb a2cg a2cm  
a2ij a2mh a2ss a2tm a2yh a2yi a3bq a3ef a3kb  
a3lm a4an a4am a5ay a5da a5kn a5lo a7bq a7cs  
a7ew a7dx z1aa z1ao z1ax z1q z2ac z2ae z2bx z2cc  
z2xa z3af z3ai z4aa z4ac z4am mjh mln mlk m9a  
ch2ld ch9tc bzlab bz2ab pilhr picd8 j3kz oa6n kfuh naj  
nkf wiz wvz wzt bam.

8DDS, T. Mony, 182 Graves Avenue, Battle Creek,  
Michigan.

6adt 6afs 6akw 6axw 6bam 6bbi 6bil 6biz 6bgo  
6bph 6bsz 6blt 6eck 6eel 6edm 6cev 6elj 6elp 6cut  
6eta 6eto 6cev 6dat 6ddx 6ji 6kb 6mu 6pi 7aij 7it 7ki  
7ob oa 4va oa4ba ch 3ij m9a mlk fw npq.

9DZI, Don Wilkes, Pierre, South Dakota.

1aay laba lahl lajx lamd laue laxa lbjk lbqt  
1blb lcb lemf lgp ikmx lsi lww 2acp 2aco 2ahm  
2aig 2alm 2bxb 2ctf 2cyr 2fr 2lc 2me 2pm 2sz-2xaf  
2xi 3ad 3aha 3baf 3bkt 3bqz 3bwt 3hg 3lk 3ll 3lw  
3ly 3mf 3op 3pl 3sa ssj 3vx 4ag 4al 4cu 4hu 4mi  
4ml 4pi 4ay 5ad 5az 5agz 5agt 5akt 5aip 5ale 5ame  
5amn 5anw 5apq 5apo 5ati 5ato 5awf 5gn 5gl 5he  
5hz 5uc 5uk 5vu 5yb 5abc 6b1b 6bpn 6bu 6byd 6c1v  
6cel 6cmg 6cmq 6cz 6dat 6eb 6fg 6ij 6ke 6kl 6oc  
6rn 6rw 6ud, 7bb 7df 7pu 7rl 7tm 7uh 8abu-8abw  
8aly 8ada 8adg 8adh 8afq 8agb 8aih 8ais 8aku 8aow  
8apm 8aul 8bco 8bgn 8bna 8boy 8bpl 8baw 8br  
8cbb 8ccm 8cgr 8cfn 8cjm 8cls 8cpq 8crm 8cwa  
8ddb 8dbm 8dip 8dqz 8doc 8dpa 8drl 8drr 8def 8kj  
8kvg 8kw 8pl 8qs 8vx 8wg.

9BDQ, Richard C. Dunlap, Osawtomie, Kansas.

a2jw a2ac a2yi a2zn a2tm a3bm a3xo a3kb a3tm  
a4rb a5aa a5ay a7hl pr4je pr4rl pr4ur ch2ld ch3ij  
ch9tc hu6dbl hu6tq hu6buic hu6dbl cz9X j1aa n9acf  
(qra?) bzlab bz1ap bz1af bz5ab f8dp f8go f8tok f8l  
f8xp l1or l1no pe6zk pe6yx z1aa z1ao z2ac z2ae  
z1ax z2xa z4as z4ag z4am z4ac z4av z4ar g6rm g2wj  
g2ao g6ox o8an ob2 (ara?) o2ld oa8e oa3b oa3k oa4z  
oa6n o2by reb8 mlam mln mlj m8f m5c m9a l1ala  
l1oo 85aq l1dd clar ch3t c3kp c3mj c4an c2mv c4gt  
c5bf c5hp c5ec c9bq huwvi ene gas 6pf neqq pox rgc  
rpe anf ffw af npo nkf kio onz nve.



2sz 2wk 2zb 3ac 3auf 3dh 3gf 3gt 3kj 3as 3ft 3gt  
3cc 3ot 3ac 3it 3dm 3kn 3mv 3ob 3nr 3av 3bu 3cu  
3oa 3tv 3xx 3dk 3hy 3yd 3oc 3rg 3ax 3kc 3att 3atc  
3acl 3akl 3ame 3cgv 3eb 3jy 3bh 3nx 3hm 3nt 3maa  
3acy 3cnx 3amu 3axe 3bds 3ada 3dx 3nd 3xl 3bna  
3dwr 3egh 3brx 3iar 3ldq 3bhp 3idd 3iak 33fz  
3zlab 3z2ab 3z5ab 3zlib 3z5aa 3z7aa 3zlaw 3zlap 3zlag  
3zlar 3zlia 3z2ap 3z2sp 3z4ap 3z4sp 3z4pr 3z4r  
3z4rd 3z4su 3z4aa 3z3bd 3z4nn 3z2vi 3z4an 3z4l 3z4n  
3z4z 3z3x 3z4n 3z4hr 3z4x 3z2ac 3z2ae 3z3af 3z2xa  
3z4aa 3z4ac 3z4ak 3z4ar.

**b2SM, Rudolph Couppez, Rue Elise, 23,  
Brussels, Belgium.**

1aae 1aao 1abz 1ac 1axa 1cal 1cbj 1ch 1cmp 1di  
1my 1wl 1xv 2afn 2fy 2arm 2atc 2av 2awq 2buy 2erb  
2cty 2ev 2cvj 2czr 2fj 2js 2ld 2sa 2uk 2wh 2xac 2zv  
2ahe 2ahk 2au 2bwi 2cbl 2co 2cpa 2hg 2te 2vi 2wo  
2bx 2cu 2ft 2hx 2if 2ahk 2efh 2cug 2dae 2dfk 2ea  
2za 2zlab 2z1ak 2z1ap 2z1aw 2z1ay 2z1c 2z1ib  
2z5ab 2f8lt 2a4z 2r4ja 2r4rx 2r4sa 2r4tk 2zlc 2ruk  
2r5nl.

**ch2AH, G. Zeller, Casilla 1840,  
Valparaiso, Chile.**

40-Meter Band.

1aci 1axm 1ga 2ahm 2ev 2fj 3te 4bu 4cu 4fa 5aab  
5at 5if 5uk 5wv 5aak 5afg 5bpg 5hm 5oi 5df 5bpl  
5akf 5bib 5kg 5ua 5za 5zlab 5z1af 5z1as 5z1bb 5z1ia  
5z2aa 5z2ab 5z2af 5z2ag 5jgw 5maa 5asl 5aa8 5bal  
5cb8 5de8 5de5 5rd5 5rev 5rf5 5rf9 5ra2 5rc 5yas  
5yfb 5zah 5agb 5am 5w 5kf 5ng 5ow 5wzy.

**ch2AR, C. Reiher, Casilla 3062, Valparaiso, Chile.**

40-Meter Band.

1aao 1aci 1axm 1eri 1ga 1yb 2ahm 3te 4bu 4by  
4ca 4cu 4fa 5aab 5apm 5apo 5at 5ava 5fc 5jf 5ed  
5uk 5va 5yb 5zai 5aak 5afg 5ats 5akt 5akx 5amp  
5apk 5ats 5az 5bhz 5bi 5bjd 5bpl 5bpg 5bpm 5can  
5cek 5cag 5chy 5cin 5cix 5cqa 5cqt 5ct 5ctd 5cto  
5cuk 5daa 5daq 5dax 5dcf 5ddo 5ha 5hm 5in 5nx 5oi  
5pr 5py 5sdm 5vc 5vr 5xi 5alk 5df 5bjz 5bpl 5adk  
5axb 5axd 5bht 5bjz 5bos 5bzi 5caw 5cet 5ck 5clj  
5con 5ctg 5dmz 5dru 5dr 5dwp 5ek 5kg 5kpu 5oo 5ua  
5xi 5za 5zlab 5z1ac 5z1af 5z1al 5z1an 5z1ap 5z1aq  
5z1at 5z1av 5z1ay 5z1bb 5z1bd 5z1ia 5z2ab 5z2af  
5zrkt 5zsn 5hufx 5hufat 5hucjl 5huetg 5ilgw 5maa  
5ml 5mj 5min 5ma 5oae 5oak 5oal 5oar 5oav 5o6n  
5rap 5ra8 5raa8 5radl 5rad8 5rae2 5rae5 5raf1 5raf4 5rag2  
5rag8 5rag9 5raib 5ra16 5ra17 5rbal 5rbf8 5rbg8 5rb14 5rb17  
5rcb8 5rd2 5rd7 5rde2 5rde3 5rde5 5rde8 5rdg1 5rdg2 5rdh5  
5rd15 5rdm9 5rdw4 5rdw9 5rdx1 5rev7 5rfal 5rfa3 5rfb5 5rfb9 5rfc6  
5rfg7 5rfh4 5rfh5 5rf9 5rga2 5rge4 5rha2 5rhe6 5rhd3 5rka9  
5rmb1 5rpz 5rpa2 5rpa3 5raul 5yckm 5yck4 5yfwx 5yicp 5yrcs  
5yri 5yam 5yas 5yld 5yli 5yfb 5yag 5z2ac 5agb 5am  
5ip 5w kel 5kf 5ng 5pp 5ow 5w 5yz wzy wqo.

## AMATEUR RADIO STATIONS

(Continued from Page 43)

four small insulating blocks. The transmitter is worked at the 3rd harmonic of a 58-foot antenna, 46 feet high. The counterpoise is also a single wire 65 feet long and 10 feet high. Plate supply comes from a 210-volt B-battery, while the set is keyed in the negative high voltage lead.

The next photo show the "works" of the 150-watt set working on 34.7 meters. This set uses the same circuit as the low power one. Plate supply is obtained from a high-voltage transformer and "S" tube rectifiers. This set has been QSO almost all of the world.

Next comes the 1-K.W. transmitter which

operates on 35.5 meters on a very small antenna, working slightly below the fundamental. Plate supply for this transmitter is obtained from a transformer and synchronous rectifier. The normal plate voltage is 2,600. The circuit is the same as is used in both of the other transmitters. This 1-K.W. set is the main transmitter at 5BG. It has been QSO the U. S. 184 different times and has been the means of working England, China, Mexico, South Africa, Phillipines, Canada, Italy and New Zealand.

5BG is now playing with a crystal-controlled transmitter. He has already put about 10 watts of crystal-controlled C.W. into the antenna and shortly expects to convert one of the larger sets to crystal control.

## OMISSION FROM 1XM DESCRIPTION

(Continued from Page 40)

### The Men Behind the Station

The majority of the Institute experimental work in radio is now carried on in the Communications Laboratory, but the "experimental bench" across the room from the operating bench is available for the use of the members of the Society in experimentation on their own apparatus or such of the Society's apparatus as is available. Unfortunately courses at the Institute leave but very little time for outside work, experimental or otherwise. At present no official credit is given for any of the work done at the station as is the case at some universities. However, we wish to take this occasion to express public thanks to Mr. J. K. Clapp, (1BYX) an M. I. T. instructor, for many practical suggestions in putting this service into operation; to Messrs. Snyder (9BNO), Dresser (1BOB-1VT), Hilton (ex-1BRQ) who, with the writer, have done the actual operating of the schedules; to Mr. Briggs (1BVL-1GW) who did a large portion of the construction of the Standard Frequency transmitter; to Mr. Snyder who built the power panel and did a large portion of the wiring; to Mr. Dyson who built the 100-watt transmitter; and to numerous others who have helped at times.

(We have just been informed that the Plotron has at last burned out. It has been replaced by a Mueller MS-1 tube rated at 500 watts output but operated at *inputs* of 100-400 watts depending upon the frequency that is being transmitted. This tube is available for this work thru the courtesy of the Tobe Deutschmann Co., Cornhill, Boston, Massachusetts.—R. S. K.)

(By the way, another error was made in the caption of Fig. 4 on page 46 of the June issue. R1 and R2 should be 5,000 ohms and R3 should be 10,000 ohms.—Editor.)



# The Communications Department

F. E. Handy, Communications Manager  
1711 Park St., Hartford, Conn.

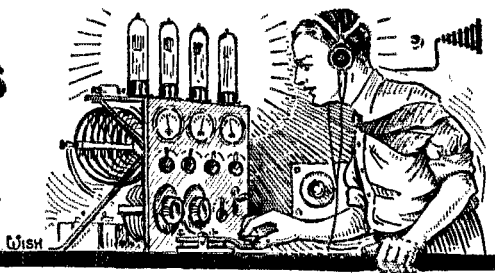

## Changing Over

**W**HEN you get this QST the summer season will be well under way. Although we have become used to working on the shorter wavelengths and although we have reached out over greater and greater distances with less and less effort, we still find that summer is the best time for rebuilding and vacations. By summertime the sleet has melted off our antenna systems. We can conduct all those experiments that had to be put aside during the cold weather. Summer is the season for changing over our stations; it is the season for getting ready for the coming cooler weather. So it is quite in keeping with the spirit of the season that we should hold our elections and have our officials taking office and getting things in running order during this part of the year.

We have called for nominating petitions (April QST, page 45; June QST C.D. page 1) for the office of Section Communications Manager from many of the Sections in accordance with the action taken by our Board of Directors last February. Elections have been held in Western Pennsylvania, Western Massachusetts, Ohio, and Illinois. The successful candidates are all listed right on this page. In many Sections but one candidate was nominated and the A.R.R.L. Executive Committee authorized the Communications Manager to cast one vote for the membership of the Section electing this candidate as S.C.M. for the two-year period of office.

The newly elected Section Communications Managers taking office at once are given in *boldface type*. They are in complete charge of handling all Communications Department matters in their Sections. The officials listed for other Sections have been asked to accept appointment as S.C.M. *protem* until nominations are received at Headquarters and all the elections have been held. These officials are busy straightening out their records and getting things in shape for an active season. In a few weeks new O.R.S. certificates will be issued by the S.C.M.s to holders of present appointments who wish to carry on and to such additional active stations as qualify for appointments. Every O.R.S. was sent a copy of the Eighth Edition of the Rules and Regulations of the Communications Department during June. This explains the qualifications, duties, and privileges of O. R. S. appointees. S.C.M.s will follow the rules rigidly in cancelling station appointments whose owners do not live up to their obligations. Here are the officials to whom you should send your report on July 26th:

SECTION	OFFICIALS
<b>ATLANTIC DIVISION</b>	
Western N. Y.	C. S. Taylor, 598 Masten St., Buffalo, N. Y.
Eastern Pa.	H. M. Walleze, 597 No. James St., Hazleton, Pa.
Western Pa.	Gilbert L. Crossley, State College, Pa.
*** Southern N. J.	H. W. Densham, ADM, 140 Washington St., Collingswood, N. J.
†*** Delaware, Md., and D. of C.	H. H. Layton, ADM, 805 Washington St., Wilmington, Del. G. L. Deichmann, ADM, Chapel Gate Lane, Ten Hills, Baltimore, Md. A. B. Goodall, ADM, 1824 Ingleside Terrace, Washington, D. C.

<b>CENTRAL DIVISION</b>	
Illinois	W. E. Schweitzer, 4264 Hazel Ave., Chicago, Ill.
Indiana	D. J. Angus, 310 N. Illinois St., Indianapolis, Ind.
*** Kentucky	J. C. Anderson, ADM, Gleggarry Farm, Lexington, Ky.
Michigan	C. E. Darr, 137 Hill Ave., Highland Park, Detroit, Mich.
Ohio	H. C. Storck, 694 Carpenter St., Columbus, Ohio.
Wisconsin	C. N. Crapo, 443 Newton Ave., Milwaukee, Wisc.

<b>DELTA DIVISION</b>	
*** Louisiana	C. A. Freitag, ADM, 8520 Forshay St., New Orleans, La.
*** Tennessee	L. K. Rush, ADM, 4 Second St., Bemis, Tenn.
*** Arkansas	L. M. Hunter, ADM, 207½ Main St., Little Rock, Ark.
Mississippi	J. W. Gullett, 819—29th Ave., Meridian, Miss.

<b>DAKOTA DIVISION</b>	
* No. Minn.	C. L. Barker, ADM, Henning, Minn.
* So. Min.	C. L. Barker, ADM, Henning, Minn.
* So. Dak.	M. J. Junkins, ADM, Bryant, So. Dak.
* No. Dak.	G. R. Moir, ADM, 820 4th St., North Fargo, No. Dak.

<b>HUDSON DIVISION</b>	
* No. New Jersey	A. G. Wester, Jr., ADM, 1075 Chancellor Ave., Hilton, N. J.
* N. Y. City and L. I.	F. H. Mardon, ADM, 1309 W. Farms Rd., Bronx, N. Y. C.
* Eastern N. Y.	H. N. Ammenheuser, ADM, 178 Quail St., Albany, N. Y.

<b>MIDWEST DIVISION</b>	
Iowa	L. R. Huber, Tipton, Iowa.
*** Kansas	C. M. Lewis, ADM, 312 E. Rutledge St., Yates Center, Kans.
Missouri	L. B. Laizure, 8020 Mercier St., Kansas City, Mo.
Nebraska	C. B. Diehl, 3006 S. 32d Ave., Omaha, Nebr.

<b>NEW ENGLAND DIVISION</b>	
Maine	Fred Best, 13 East Crescent St., Augusta, Maine.
Connecticut	H. E. Nichols, 30 Elmwood Ave., Bridgeport, Conn.
New Hampshire	V. W. Hodge, 227 Main St., Claremont, N. H.
*** Rhode Island	D. B. Fancher, ADM, 86 Franklin St., Westerly, R. I.
Vermont	C. T. Kerr, Poultney, Vermont.
Eastern Mass.	R. S. Briggs, 893 Ashmont St., Dorchester, Mass.
W. Mass.	A. H. Carr, 30 Vassar St., Worcester, Mass.

<b>NORTHWESTERN DIVISION</b>	
* Montana	A. R. Wilson, ADM, Ramsey, Mont.
* Washington	Otto Johnson, ADM, 4340 30th West, Seattle, Wash.

- \* Oregon A. C. Dixon, ADM, 1350 East 36th St., Portland, Ore.
- \* Idaho K. S. Norquest, ADM, Weather Bureau, Boise, Idaho.
- \* Alaska Leo H. Machin, ADM, Box 452, Cordova, Alaska.

**PACIFIC DIVISION**

- \*\*\*\* So. Sect. Calif. L. E. Smith, Mgr., 340 No. Dists. 1, 2, 3 Painter Ave., Whittier, Calif.
- Arizona W. S. Wiggins, ADM, Route 1, Whittier, Calif.
- D. B. Lamb, ADM, 229 W. First St., Mesa, Ariz.
- \*\* Section 4, No. F. J. Quement, 51 Pleasant St., San Jose, Calif.
- \*\* Section 5, No. P. W. Dann, SM, 562--35th St., Oakland, Calif.
- \*\* Section 6, No. St. Clair Adams, ADM, Eureka, Calif.
- \*\* Nevada, No. Cal. C. B. Newcombe, ADM, Yerington, Nevada.
- Hawaiian Section K. A. Cantin, 1593 Piikoi St., Honolulu, T. H.

**ROANOKE DIVISION**

- \*\*\* North Carolina R. S. Morris, ADM, 413 S. Broad St., Gastonia, N. C.
- \*\*\* Virginia J. F. Wohlford, ADM, 118 Cambridge Ave., Roanoke, Va.
- \*\*\* West Virginia C. S. Hoffman, ADM, 126 Chantal Court, Wheeling, W. Va.

**SOUTHEASTERN DIVISION**

- \*\*\* Florida W. F. Grogan, ADM, Box 316, Ft. Myers, Fla.
- Alabama A. D. Trum, 217 Catoma St., Montgomery, Ala.
- \*\*\*\* Georgia -- South J. Morris, ADM, 58 Frederica St., Atlanta, Ga.
- Porto Rico -- Isle A. Dupre, ADM, 290 Wofford Campus, Spartanburg, So. Caro.
- Luis Rexach, ADM, Box 319, San Juan, Porto Rico.

**ROCKY MOUNTAIN DIVISION**

- \*\* Colorado C. R. Stedman, ADM, 1641 Albion St., Denver, Col.
- \*\* Wyoming N. R. Hood, Manager, 1022 S. --Utah Ash St., Casper, Wyo.
- Art Johnson, ADM, 247 E. 7th South St., Salt Lake City, Utah.

**WEST GULF DIVISION**

- \*\*\* Northern Texas W. B. Forrest, Jr., ADM, 502 Royal St., Waxahachie, Texas.
- Southern Texas E. A. Sahn, Box 569, New Braunfels, Texas.
- Oklahoma K. M. Ehret, 2904 N. Robinson St., Oklahoma City, Okla.
- \*\*\* New Mexico .....

**CANADA**

**MARITIME DIVISION**

- \* Newfoundland Loyal Reid, Avalon House, St. Johns, Newfoundland.
- \* P. E. Island T. A. Hyndman, Charlottetown, P. E. I.
- \* New Brunswick T. B. Lacey, N. B. Power Co., St. John, N. B.
- \* Nova Scotia Section W. C. Borrett, 14 Sinclair St., Dartmouth, N. S.

**ONTARIO DIVISION**

- Central Ontario A. E. Williams, ADM, 86 Madison Ave., Toronto, Ont.
- Eastern " F. A. C. Harrison, ADM, 181 Hopewell Ave., Ottawa.
- Southern " J. A. Varey, ADM, 43 York St., St. Catharines, Ont.
- Northern " Wm. Sutton, ADM, c/o Victoria Hotel, Ft. William, Ont.

**QUEBEC DIVISION**

- Quebec Section Alex Reid, Manager, 202 Birch Ave., St. Lambert, Que.

**VAN-ALTA DIVISION**

- \*\* British Columbia Felix E. Batt, DS, 211 8th Section (including Yukon territory Ave. E., Prince Rupert B. C.
- \*\* Alberta Section Wm. Schopp, DS, 926 5th Ave., N. E., Calgary, Alta.

**PRAIRIE DIVISION**

- \*\* S a s k a t o n E. J. Maynard, ADM, Morse, Sask.
- (including Northwest territories)
- \*\* Manitoba Sec- F. E. Rutland, Jr., ADM, 452 tion St. John Ave., Winnipeg, Man.

**The New Reporting Month**

The change in organization becomes effective July 1, 1926. Coincident with this change the reporting month of all Official Relay Stations will be from the 24th of one month to the 25th of the following month inclusive. The report shall be mailed direct to your Section Communications Official on the 26th of each month. Reports sent more than one day later than this date will stand little chance of getting into QST. Form 1 cards sent to Hartford directly or in error will be returned promptly to the Section Communications Managers for inclusion in the reports which they prepare.

**Assistants to the S.C.M.**

Under the provisions made by the Board of Directors for cutting down the time required for getting reports to Headquarters, no place was made for Division Managers, District Superintendents, or City Managers because the routing of reports and applications for appointment through so many links in our organization chain is necessarily a cause for delays. The new Rules and Regulations insure that reports will be handed always directly over the ORS-SCM-CM route. They also provide that the new Section Communications Managers may appoint such Assistants for specific work as may be deemed necessary by the Communications Manager. Your new officials are already authorized to appoint Route Managers to help in lining up routes and stations working on schedule. These appointees will be under the S.C.M. and report separately to him on the progress of their specific work each month. It is hoped that many of the former District Superintendents and City Managers will be able to help their S.C.M. by accepting some appointments which they will be able to handle in good shape because of their experience in the old work of collecting reports.

Every S.C.M. is pledged to put his Section on the map and to pass along to QST every worthwhile report that you send him. Every League member-station and Official Relay Station in each Section should feel it his duty to actively support and cooperate with his S.C.M. in every way possible. The new officials have seriously undertaken to give you their best. Please see that you do yours, OM. Get acquainted with your S.C.M. at the first possible opportunity. Write him often with your suggestions.

**Sectionalizing**

The logical Sectionalizing of each Division is of course determined from a consideration of the number of active stations one man can conveniently and successfully work with and develop and from geographical limitations. If one Section contains more than 50 Official Relay Stations (or active reporting stations), it will probably be too big a job for one man to handle

\* The closing date for the receipt of nominating petitions from these Sections is noon of July 15, 1926. If you haven't signed a petition for the man you want in office, write one out, get the signatures of five League members on it, and send it to the Communications Manager.

\*\* The sectionalizing arrangement is announced herewith. In all Sections except Northern California the nominating petitions will be received up to noon of Aug. 15, 1926.

\*\*\* No nominating petitions have been received for candidates who can accept the election--in most cases no petitions at all have come in. The date for receipt of nominating petitions is extended to noon of Aug. 2, 1926. If no change in officials is desired, petitions confirming your temporary officials will be welcomed.

† The new Sections include the territory now under several temporary officials listed. Where ADMs are mentioned they will continue to receive reports direct from stations in their respective states or territories, writing a condensed report from the information received and sending it direct to ARRL Headquarters except in Southern California where the report should be turned in thru Mr. Smith.

efficiently. On the other hand, there are great opportunities for the development and growth of Sections containing a smaller number of active stations and having an active leader. Of course, it is not wise to break up our organization into too small units either. On one hand, we must deal with the problem of thickly populated Sections of relatively small area; on the other, with sparsely settled districts having stations remotely located with respect to the Section Manager's Headquarters. Of course, the sectionalizing must be carried out as more or less of a compromise, depending on the different factors involved. Each Division offers more or less of a special case to be treated with the big general principles kept in mind.

Your Directors and officers favor the formation of Sections wherever there is a sufficient membership to warrant a Section, so that stations in any part of the country remote from the Headquarters of a Section Communications Manager can get together if they wish and form a Section of their own, reporting independently to Hartford. Before such a Section can be formed, the consent of both the Division Director and the Communications Manager must be obtained. A petition requesting the formation of a separate Section, defining the limits of the new Section, giving the approximate number of active reporting stations, signed by a sufficient number of League members to justify action, should be presented to the Communications Manager if further sectionalizing is desired.

The sectionalizing in each Division was announced after deliberation by the Communications Manager and the Division Director (who, of course, speaks for the best interests of his Division membership). The sectionalizing had to be carried out in a manner that insofar as possible gives us a uniform national organization. The Sectionalizing plans were begun right after the Board meeting in February and have been pushed along steadily each month since. By fall, the change will be about complete and things will be in good working order.

This notice of changed reporting automatically brings the new order of things into being. In some cases, a few elections must still be held before the new organization is complete in all respects.

## Notice

To all A.R.R.L. Members of the Rocky Mountain Division, Northern Pacific Division, Vanalta Division, and Prairie Division.

The sectionalizing of the territory in your Division is indicated as follows:

- Rocky Mountain Division (two sections).  
Colorado Section, Wyoming and Utah Section.
- Northern Section, Pacific Division (four sections).  
Section 4, Northern California; Section 5, Northern California; Section 6, Northern California; Nevada Section.
- Vanalta Division (two sections).  
British Columbia Section (including Yukon territory), Alberta Section.
- Prairie Division (two sections).  
Saskatchewan Section (including Northwest territories), Manitoba Section.

The Sectionalizing plan announced in April *QST* for the Pacific Division did not prove entirely satisfactory to the members of the Northern Section. In response to the request of the membership through their Director we now indicate the revised sectionalizing as above.

Nominating petitions from all these Divisions are hereby solicited. The proper form for nomination was shown on page 45 of April 1926 *QST*. The signatures of five or more members of the League in good standing are necessary on a petition to make it a valid nominating petition. There is no limit to the number of petitions that may be filed but no member shall sign more than one such petition. In all cases except that of the Northern Section of the Pacific Division such petitions must be filed at A.R.R.L. Headquarters, Hartford, Conn., by noon of the 15th day of August, 1926. The elections in these sections will take place in August and September in Sections where there are two candidates for the office. In the Northern Section of the Pacific Division the members of Section 4 got busy and sent in a petition for their candidate before the closing date in April *QST*. As soon as the resectionalizing was made clear, there being no other nomination forthcoming from this Section, the Communications Manager was able to cast the necessary vote for the members of Section 4, com-

pleting the election of their candidate. The closing dates for the receipt of nominating petitions in the Nevada Section and in Sections 5, and 6 of Northern California are noon of the 15th day of September, 1926, noon of the 15th day of December, 1926, noon of the 15th day of March, 1927. Elections will be held immediately after the closing dates given if there is more than one nominating petition on file so that it is necessary.

Members are urged to take the initiative immediately and to file nominating petitions for the officials of each Section now having temporary officers.

F. E. Handy, Communications Manager.

## Army-Amateur Notes

**T**HIS month we have some FB news for these columns! The 1st Corps has started an operators' proficiency course that we will all want to get in on. That's just a part of the news though. A letter came through the other day that makes us feel good all over. Some of us who do not live right alongside a National Guard or Organized Reserve Unit—and some more of us who were late in writing our A.R.R.L. Representative or C.A.S.O. so that the chap across town got lined up with the local unit before we did—are particularly happy about the latest news.

The letter we mention authorized all the Corps Area Signal Officers to set up AUXILIARY Radio Nets providing for Army Amateur Radio Stations in communities where there are no National Guard or Reserve organizations permanently located, but where these organizations might have to serve in case of emergency. These nets will also provide for stations located where there are army organizations whose known wants have already been filled but where there still remain a number of amateur radio stations not included in the National Guard and Reserve nets. The army plan provides for all of us. Besides the Army-Amateur appointment certificate that you receive, you will have an opportunity to take part in some of the interesting activities that are getting under way. Your A.R.R.L. Army-Amateur Representative, or your C.A.S.O. will be glad to get your application. If you are not sure of the address, send the application for appointment as Army Amateur Radio Station to A.R.R.L. Headquarters and we will see that it is forwarded properly.

**1ST CORPS AREA**—The First Corps Area announces a course of instruction for amateur radio operators fitting them for duty as army radio operators. Certificates of proficiency in radio code will be awarded all who complete the sub-course in Radio Code Practice, regardless of their place of residence. Certificates of Proficiency as Army Radio Operator will be awarded residents of the First Corps Area who complete the four sub-courses of the Radio Operators Course.

The course offered the radio amateur is called the Radio Operators Course. It is divided into four sub-courses: Radio Code Practice, Army Organization, Principles of Radio and Radio Procedure. The first sub-course is broadcast on 80 meters every evening, excepting Sundays, by 1YC, 26th Signal Company, Commonwealth Armory, Boston, Mass. The schedules is completed in exactly six days. It will be repeated each week.

Receiving tests at 15, 18 and 20 words per minute are included. Each student passing these three tests is required to make application by radio message for a Certificate of Proficiency. This certificate will be given anyone located any place in the United States who completes the sub-course in Radio Code Practice, whether he completes the other sub-courses or not.

The other sub-courses are given by correspondence and are open to students residing in the First Corps Area only. Application may be made to the Liaison Officer, Army Amateur Radio Stations, Army Base, Boston, Mass., for enrollment in the Radio Operator's Course.

All who wish to avail themselves of the instruction in Radio Code Practice only may do so without making formal application and will be awarded Certificates of Proficiency on the completion of the course.

The instruction in single letters given from 6:50 to 7:10 pm is sub-divided into six groups of six characters each. One group will be studied each night, as follows: Monday: D H 8 9 X Z. Tuesday: 6 O Y L J Z. Wednesday: 7 Zero 3 4 K 5. Thursday: W E S M A U. Friday: V R F 1 T I. Saturday: B N G Q C P.

All stations are requested to refrain from transmitting on 80 meters during the operation of the schedule.

## Rules

1. The course of instruction in Radio Code Practice is open to all amateurs in the United States.
2. All instruction will be in code groups and students will PRINT their copies with pen or pencil grouping the characters properly as transmitted.
3. The date the test was taken and the speed will be shown on the test paper, which will be mailed to the Liaison Officer, Army Amateur Radio Stations, Army Base, Boston, Mass., for grading.
4. A two minute test will be given daily at a speed of 15, 18 or 20 words per minute. Students passing tests at 15, 18 and 20 words per minute will be awarded Certificates of Proficiency in Radio Code Practice.
5. Test copies should not be sent in for grading unless the student knows that they are nearly correct.
6. Before receiving a Certificate of Proficiency, the student will (after passing the 15, 18 and 20 word tests) apply to the Liaison Officer for same by radio message through station 1YC.
7. All students are placed on honor not to give or accept assistance in passing tests.

**1YC SCHEDULES!** Weekday transmissions start at 6:50 pm EST. For ten minutes one letter groups are sent at a rate of 5 words per minute. From 7 until 7:30, two, four and five letter groups are sent at rates of six, twelve, and eighteen words per minute respectively. The next twenty minutes are spent on three and five letter groups at speeds of from seven to twenty words per minute. During the time from 7:50 to 8:00 pm, two minute tests are sent at 15, 18, and 20 w.p.m. Between ten and eleven o'clock is left open in which to give tests for proficiency certificates to those who wish to qualify.

**2ND CORPS AREA**—Plans are under way to organize an "Army Amateur Auxiliary Radio Net" for each state in this Corps Area. Such nets will consist of only those qualified amateurs selected by the A.R.R.L., who, because of their geographical location, could not be assigned to a military unit, or because assignments to military organizations in their vicinity have already been made. Amateurs assigned to the auxiliary radio nets will receive their instructions from the Corps Area NCS, Station 2SC.

Amateurs assigned to the 78th Division held a meeting at Division Headquarters, Newark, N. J., under the direction of Lieut. Colonel Wade, who has taken charge of amateur work for that division. Many important questions were discussed and schedules arranged. A meeting of amateurs of the New Jersey National Guard was held, Lieut. George L. Townsend, S.C., presiding. Much interest was taken and a great deal accomplished for the furtherance of this plan in that State.

A photostat copy of the 2nd Corps Area Radio Amateur Net proper with stations, call letters and schedules tabulated thereon, has been forwarded to each amateur concerned.

Additional amateurs assigned last monthly report.  
2zv x2dv x2eg 2aob 2aau 2kr 2als 3jw 3an 2wr 3vx 2eqz 3btz 3bnz.

**3RD CORPS AREA**—The tests being conducted with ARRL operators in the Third Corps Area are still going on and are proving very interesting to the Army officials having the work in charge. Twenty-one have qualified and will be appointed Army Amateur Radio Stations. In the meantime, there is a need for more volunteers. Operators and stations are needed in many cities where National Guard Units are stationed. Get into the game, ready to serve the U. S. A. if you should be needed.

**4TH CORPS AREA**—The organization of National Guard Units in several states in this Corps Area is now in progress. 4RM of Atlanta has been designated as the Control Station of the Governor's Net for Georgia. Mr. Cobble is now assisting Mr. J. Morris (4IO), ARRL representative in the organization of the Georgia National Guard Net. Mr. Justice (4TS) is assisting in the organization of the National Guard Net of North Carolina.

Since the last report published in May QST, certificates have been issued to: 4fj 4rm 4it 4ts 5ads 5afs 5api. Fifteen stations have been designated to serve the Organized Reserve, six the National Guard, one as Corps Area Control Station (4IO), making a total of twenty-two.

**5TH CORPS AREA**—The weekly schedules of the Corps Area Amateur Net has been maintained throughout the month and considerable business handled. The 100th Division has seventeen amateur stations lined up for its divisional net and the other Divisions in this Corps are progressing equally well.

**6TH CORPS AREA**—The Sixth Corps Area is full of pep. Some days as many as 500 words have been sent from the Corps Net Control Station. Some changes have been made in the original assignments to secure better and more responsible personnel at important points. Letters are continually coming in inquiring about Army work.

Great credit is due 9AFF for his untiring efforts, even under adverse conditions, to make this plan a success. What is the matter with you fellows in Springfield, Illinois? We have sent questionnaires, written you letters, broadcast through QST and over the air, but with poor results. Every other Governor's Office is covered and handling traffic while our own state capital is apparently asleep at the switch. Here's hoping some of you fellows down there read this and get busy before some of your friends start cutting this clipping out and mailing it to you.

We have not been able to raise you, 2CXL, and have had to send our stuff through a relay station not far from yours. We are going to make a schedule with you pretty soon; however, 9AFF has just put in a 50 watt bottle and thinks he can go at least half way round the world. Watch us grow!

Illinois, Michigan, and Wisconsin applicants: Write to the Signal Officer, 6th Corps Area, 1819 W. Pershing Rd., Chicago, Ill.

**7TH CORPS AREA**—Appointment certificates were issued as follows: 9ebc, first alternate station for 3rd Battalion, 205th Infantry, National Guard Minnesota, St. Cloud, Minnesota; 9aek, first alternate station to the Governor's Net control station, Topeka, Kansas; 9dbb, to serve Headquarters company, 137th Infantry, Kansas National Guard, at Wichita, Kansas. The final organization of the 88th Division Army Amateur Net covering Minnesota and Iowa is held in abeyance pending assignment of the Control station at Minneapolis.

A net of amateur stations who are not located so that they can serve an established military unit is in formation. The net control station will be at Omaha at the CASO's Headquarters. Here is an opportunity for every amateur in North Dakota, South Dakota, Minnesota, Nebraska, Iowa, Kansas, Missouri and Arkansas who has not yet been designated to an army unit. Write your ARRL Army Amateur representative, for the 7th Corps Area, Mr. C. E. Diehl, 3006 South 32nd Ave., Omaha, Nebraska, for details on getting lined up for one of those appointment certificates.

**8TH CORPS AREA**—The Governor's Net of Texas is in operation and messages pertaining to National Guard affairs are handled by this method very satisfactorily.

One of our first problems was to find and put into effect a schedule suitable for all operators in the net. A conference between Mr. L. D. Wall, local representative of the ARRL, the Corps Area Signal Officer, 5AIN (net control station), and the various amateur operators throughout the State obviated this fault. The following schedule was the result: 6:30 pm to 7:30 pm daily except Sunday for all amateur stations throughout the State of Texas, and 8:00 pm to 9:00 pm daily including Sunday for Station 5AIN. The handling of traffic need not be confined to these hours and this schedule was merely announced in the interest of uniformity. All work on the amateur radio operator's part, of course, is entirely voluntary and the success in handling traffic depends entirely upon the willingness of the amateur operators to cooperate.

We have also found it desirable to have a limited number of relay stations at points where no National Guard unit is located. These are located in college towns in connection with ROTC units in towns along the Mexican border where their usefulness could be utilized in case of emergency and at such other points as is deemed beneficial to the amateur operators and the net.

**9TH CORPS AREA**—Over fifty certificates of appointment have been made. The operation of the Ninth Corps Area and Governor's Nets in California and Utah commenced about June 10th. The following stations have been appointed in this Corps Area: 6rw 6kw 6hj 6ls 6um 6bhg 6rv 6crs 6ctf 6cag 6im

6wp 6zx 6cax 6ta 6pr 6aas 6rl 6brm 6atb 6dai 6anr 6chi 6ahw 6nx 6bon 6csx 6hnu 6zv 6nh 6km 6bch 6cul 6cgk 6bol 6bl 6bgm 6bcp 6aoy 6hu 6bbq 6bgo 6bcm 6ccl 6cb 6asv 6si 6buu 6eva 6cug 7ps.

## Club Activities

**CALIFORNIA**—The Central California Radio Club of Oakland meets every Friday night at the Melrose Library. The club organized last February and has now grown to have 25 members. It is hoped to have a vessel equipped for holding regular meetings before very long. A real station aboard is planned having a short wave transmitter and receiver n'everything. FB!

**CONNECTICUT**—At the charter meeting of the Twin City Radio Club of Connecticut held at West Haven on May 17, it was voted that the Secretary write the A.R.R.L. for the necessary affiliation application blanks. 1BAU, 1BOA, 1CHL, 1AUU, 1CTP, 1FY, 1BJK, 1ATH, 1BQH, 1AUK and 1BHM are charter members. We hope to have activity reports for these pages often in the future.

**ILLINOIS**—The Chicago Radio Traffic Association has been having code practice for members at the last few meetings and everyone thinks it great stuff. Radio Inspector Beane gave the gang some interesting dope on oscillating crystals and other matters of genuine amateur interest. Thru the cooperation of the membership of the C.R.T.A., a short wave set was loaned the Supervisor to help him in checking amateur conditions to keep amateurs in the proper wavebands. It looks like a busy summer season was ahead.

**INDIANA**—The Radio Club of Tri State College has just installed a 20 watt transmitter (9BGT). A continuous watch is kept on 80 meters from 6 p. m. until midnight C.S.T. and from noon to 6 p. m. C.S.T. The club is now arranging schedules with stations in different parts of the country to help in moving traffic quickly and directly.

**MANITOBA**—The Winnepeg Radio Traffic Association will hold bi-weekly meetings throughout the summer. The prize set recently raffled went to Mr. J. McLash of Winnepeg. May 11 c4DT gave an interesting account of his experiences as a commercial operator. May 25 the gang made traffic plans for the summer. A message box has been placed at the Tourist Bureau to help on traffic originated. Several valuable prizes will be given the stations making the best showing this summer. Points will be awarded for consistency and reliability of operation and for traffic handled.

**MASSACHUSETTS**—The Radio Club of Melrose hold weekly meetings over the air Friday nights between 7 and 8 p. m. 1APK is the master control station. He calls each member in turn and each reports any new business. There are never any mixups and things are conducted in orderly fashion. At the last monthly meeting June 7, Cap't John Ferriter of the First Corps Area gave an interesting talk on Army Radio.

The Eastern Massachusetts Amateur Radio Association held its first annual banquet at the engineers club, Boston, June 1st. Some 40 hams were present and all had a good time.

**MICHIGAN**—The Radio Research Club of Detroit are handing red hot press notices for the Graphic World—Detroit's newest illustrated newspaper. Most of the news comes in through schedules with outside radio stations.

**NEW JERSEY**—The Eclipse Radio Club of Orange held an election of officers at the last meeting. After the final touch has been added to the club house a photo with a picture of "the gang" will be taken. 2QG is the club station and has been piling up some creditable records.

**OHIO**—The Findlay Radio Club's new shack is finished. Meetings are held every Thursday. A transmitter and receiver are being installed.

**NEW YORK**—The number of licensed operators who get their points from the Yonkers Radio Club steadily increases. The gang is looking around for new quarters where a club transmitter may be located.

**PENNSYLVANIA**—The Western Pennsylvania A. T. A. have had regular and well-attended meetings. They plan to publish an official organ of interest to both transmitting amateurs and broadcast listeners in their territory. The Vigilance Committee work has progressed very favorably. 8CEO gave a technical discussion showing how to use a low voltage

d.c. motor correctly in getting high voltage for a transmitter. A big ham-fest was held May 29 with over 100 amateurs present. Election returns were announced and the Association pledged its support of the successful candidate. Director Woodruff (8CMP) gave a fine talk on cooperation between League members and their Director—and made some humorous remarks in addition. 8AJU reported on the arrangement made with local papers to originate A. R. R. L. messages for all parts of the world. 8AAX told the members of the part that publicity plays in the growth of a club.

**RHODE ISLAND**—The Providence Radio Association has just held its annual election; Pres. 1AEI; Vice-Pres. 1AKK; Sec'y, 1AFO; Treas. 1CAB; Librarian, 1BIL; Chairman Technical Committee, 1AAU. Mr. Learned is now building a transmitter for the Association that will soon be on the air with the call, 1LI.

**VIRGINIA**—The Richmond Short Wave Club is progressing nicely. There are now 20 members in good standing. A committee takes care of banquet arrangements each month. Director Gravely has approved the organization officially so that it may become affiliated with the A. R. R. L. With the cooperation of the old timers, and with the new policy of the Club we expect to see lots of doings at Richmond.

\*\*\*\*\*  
 \*  
 \* **Lawrence K. Garland—8RRB** \*  
 \* 304 South Fourth St., \*  
 \* Apollo, Pa. \*  
 \* Orig., 6; Del., 2; Rel., 257; Total, 265. \*  
 \*  
 \*\*\*\*\*

BRASS POUNDERS' LEAGUE				
Call	Orig.	Del.	Rel.	Total
8RRB	6	2	257	265
8AYP	70	6	174	250
1BIG	48	26	165	239
8DHX	73	22	136	231
8EU	24	23	180	227
6HJX	44	69	84	197
9EAE	14	3	151	196
9DTK	85	31	78	194
9BFG	30	43	118	191
2APT	30	10	150	190
8GI	15	45	112	172
6AXW	127	11	28	166
5YB	35	19	110	164
9IX	18	14	122	154
6BQ	23	1	130	154
6BJD	43	25	86	154
8XE	2	4	134	140
7GE	49	16	68	133
6BUC	125	5	2	132
3ZO	3	—	127	130
8APY	78	27	16	121
8DBM	28	28	64	120
1ATV	75	6	36	117
2NZ	91	25	—	116
1AMZ	39	41	33	113
9DYL	26	—	86	112
8RJ	35	27	46	108
3BWT	25	17	65	107
8AHO	46	48	8	102
2AJE	15	12	74	101
1JL	55	22	24	101
9NV	39	33	28	100
1LM	4	—	96	100

7YA would have been included above if the number of messages originated, delivered, relayed, and total had been turned in to Headquarters. Please be sure to send all the information next time, OMs.

The same consistent stations are with us again. 8RRB came to the top with a bang. 8EU dropped to fifth place, while 8DHX is fourth this month. 6BJX has been sick but rated sixth. 8AYP pulled right up next the top with 1BIG close behind. The warmer weather and generally poor conditions show their effect in the figures above. 8GI, 8AHO, and 6BJX delivered most messages this time. The traffic summary shows a drop of 40% in message handling due to summer and the B.P.L. is decreased somewhat in size on that account. Which of the above stations is going to collect that Traffic Trophy?

1ATJ should have been listed in the Brass Pounders League last month. His report read Orig: 26, Divd: 35, R'yd: 540, Total, 601 messages. This was turned in on time to 1GL but did not reach Headquarters in time for QST. 1ATJ used \$10 worth of juice, kept schedules with six ORS, and neglected his YL and wondered why he didn't at least make the BPL. Congratulations on the good traffic work, OM. Vy FB'.

**FLASH!** Another message via 8GZ brings first news of our stations qualifying in the Australian Reliability Tests. Here it is in part:

HR MSG FM SYDNEY AUSTRALIA 2YI  
NRI JUNE 12 CK 276

TO HANDY ARRL HARTFORD CONN

TESTS PROVE THOROUGHLY SUCCESSFUL NOTWITHSTANDING CONDITIONS... TO DATE FOLLOWING AMERICAN STATIONS HAVE QUALIFIED TEST MESSAGES IN MOST CASES BEING 100% ACCURATE 3LW 4IZ 5ARN 5AGU 5HE 6NX 6AJJ 6CKV 6CMQ 6APS 7NH 7DF 7LQ 8GZ 8ADG 9CP 9DRD ONLY 20 METER STATION REPORTED 6DAT...8GZ AND 5HE STAR PERFORMERS...MANY REPORT SPLENDID SPIRIT SHOWN BY STATIONS WHICH EXCHANGED TRAFFIC...TESTS HAVE DEFINITELY PROVED AMATEURS CAN HANDLE BULK TRAFFIC WITH ABSOLUTE ACCURACY ACROSS PACIFIC A FACT NOT UNTIL NOW ADMITTED BY NON AMATEUR INTERESTS...PROVIDED WONDERFUL STIMULUS TO AUST HAM WORK...FULL REPORTS AND CERTIFICATES TO BE MAILED....

HULL WIRELESS INSTITUTE  
AUSTRALIA

2TM 2YI 2IJ 2CG 2CS 3AD 3EF 4AN and 7DX are the Aussies who have so far qualified by putting 500 word test message thru to ARRL Headquarters. Reports are still coming in and a complete report from Australia cannot possibly reach QST before the September or October number. 3LW 4JN 4MV 4NH 5AAB 5HE 6AJJ 6CMQ 6NX 7AAB 7DF 7NF 8GZ 9DNG 9EKT 9MB and 9ZT QUALIFY BY RECEIVING Australian 500 word tests correctly. A full report will follow when all the dope is in.

## Traffic Briefs

9CGY worked 68% of the stations he called during the reporting month. Here is a good check on over all station operating efficiency. Keep a good log of your own operation and look it over each month to see how well you are getting on. The better judgment you use in calling and the steadier and stronger your signal, the better figure you can report. Can you beat 9CGY, OMs?

A message just received from 6BVG via 2CUA reports that the yacht Poinsettia sailed from San Pedro for Honolulu June 12. She carries a 500-cycle short wave set working in the 40-meter band. She hopes to QSO the east coast. How many of the gang will connect with KFWH?

hu6CJLJ passed a message from the local Radio Corporation of America office to the Johannesburg South Africa staff. Regular schedules with oA8B did the trick.

bg1JT, Joseph T. Tasker, 61 Hadfield St., Georgetown, British Guiana is leaving Georgetown for a trip in the wilderness. He carries with him a 20-watt outfit using the above call. Drop him a line if you hear him but don't expect a QSL until his return home.

During the Australian tests, 4XE (89.15 meters) at Winter Park, Fla. used voice with a2TM. H. Turner, 18 Erith St., Mosman, Sydney, Australia for twenty minutes. Reception was reported clear and strong. We believe this is our first good radiophone contact with Australia. Both a2TM and 4XE were r? at Hartford during period of the contact. Congrats on a new record! Wouldn't it be great if we all had X calls and could use voice on 40 meters?

1CJR will again operate at Medomak Camp, Washington, Maine this summer. There are two transmitters (one for portable work) working on 40 and 80 meters. Schedules for work after 9 p. m. EST are desired. Arrangements have been made with 1BIG to handle a lot of the regular traffic reliably thru the M.M.P.C.

Amateur Radio came to the rescue of the Goltra Barge Line towboat "Iowa". KFLT, when she ran her tow aground in six feet of water in the Ohio River near Stephensport, Ky., on May 11th. In the accident her master, Capt. John Warner, was thrown overboard and lost.

The Goltra interests have equipped the "Iowa" with short-wave radio for experimental communication, testing its efficacy for their purposes. The "Iowa's" operator is Thos. B. Gibbs of 9DOQ, University City, Mo., and communication with St. Louis, where the Goltra offices are located, has been via 9DMJ, the station of Delmar W. Fowler, at St. Louis. At 8:16 p. m. E. S. T. on May 11th, Staff Sergeant N. Hagmann, operating station 2KP at Mitchell Field, L. I., heard KFLT calling "urgent message for St. Louis." Nobody answering her from that direction, Hagmann finally called and raised her and received urgent messages notifying the owners of the accident and asking that 9DMJ get on the air, which he was asked to send to St. Louis by Western Union. This he did. Fowler was located and within the hour came on the air to acknowledge to KFLT, to say that relief was started, and to direct the search for Capt. Warner's body. Mr. Goltra, owner of the line, camped at 9DMJ that night. Because of the skip effect on the 40-meter band, 9DMJ and KFLT were unable to work direct, but maintained contact via 5AAB—some circuit! All three stations were copied solid thruout the night at 2KP (good call for an Army man). Good work all around. It is reported that the success of the "Iowa's" radio will lead to the equipping of the Goltra's "Illinois" and "Minnesota."

The Radio Club of Hawaii 8BUC, did some neat work on April 19th. Sixteen messages were sent single, direct to u2KG who used a typewriter to copy with. Some DX and snappy operating, too.

2AKV is handling Weather Bureau reports on schedule with FTJ on 75 meters. The reports come along from NAH over the land wire and a regular schedule with FTJ puts 'em thru speedily. FTJ is the SS Jacques Cartier bound for Harve. FTJ can be heard working PL on the same QRH. Some amateur finds a new way to be of service and make a name for himself everyday. This one is FB!

Sgt. DeRemer, piICW, has some new stationery that lets you know right where he is on the map by giving the latitude and longitude of his station. A "get acquainted" picture of himself is another feature that is worthy of note. Between October 15, 1925 and March 31, 1926, piICW handled 2784 messages, 1557 originated, 370 delivered, 357 relayed. Tie this good work if you can.

2APJ is chief op at the new official station of the American Sales Co., (2AZM) 643 West 171st St., N. Y. C. which has just gotten on the air.

J. W. Chapman, 7TE, at Anvik Alaska is just perking with a 50 watt on 80 meters. He is using horizontal reception to good advantage. Give him a call when you hear him, gang.

For 18 months pr4KT (B. Pinero, Carolina, P. R.) and u3JW have had a regular working schedule, handling 90% of the radio traffic to and from the island. pr4KT operates a large dairy farm about 15 miles from San Juan. Cattle have been ordered from the New York Markets; shipments of cigars have been directed from Porto Rican wholesalers; bulletins from doctors in N. Y. C. have been sent to relatives of their patients in far-off Porto Rico; messages bearing friendly and sometimes tidings of sickness and death have been handled. Messages of importance are often phoned to their destination in the U. S. A. and the answer radioed back to 4KT the same evening. Consistent operation for a worth while cause brings its own reward. Instead of CQing all the foreign countries having international intermediates every night, why not increase the good times you get with a transmitter by doing some local work—and by handling some traffic with other reliable stations?

# Official Broadcasting Stations

Changes and Addition:  
(Local Standard Time)

Call	7.00	10.30	12.30	Days of Transmission
ISZ	pm	pm	pm	Mon., Wed., Fri.
ISZ**	---	41.9	---	Sat., Sun.
GANO*	---	---	---	Daily except Sun.
8BSU***	39	---	---	Mon., Fri.
SDME	38.2	---	---	Tues., Fri.

\* 41.5 meters, 7.30 and 10 pm.  
\*\* 1.30 pm, 41.9 meters.  
\*\*\* 9 pm, 39 meters, same days.

Miss Mildred Lorentson (1AID) suggests that we use QWP to be sent at the beginning of each QSO to give the other chap an idea of the rate at which he can send without fear of getting a "Sri OM QRM btr QSZ". This new Q signal should be useful to the old timer and beginner as well.

It is proposed that the new abbreviation be interpreted as follows: QWP? At what rate do you wish me to transmit to you?  
QWP... Please send to me at ..... words per minute.

Give her suggestion a try everybody. If the fellow you work hasn't heard about QWP tell him about it. When one is reassured that a definite transmitting speed can be copied in good shape, there will be less of the unnecessarily slow sending. Fellows breaking into the game can use the signal to keep a high speed operator from going above their modest abilities. All of us can request the speed we can copy best thru existing QRM and QRN conditions. As Mildred says, "We all enjoy a good snappy QSO. Let's see if we can't have more of them!"

Herb Gordon, 8BAS in the old spark days is now back again on the air as 8JB. He relayed 40 or 50 messages in the first 20 days he was on the air. Glad to have you with us again, OM.

## TRAFFIC SUMMARY BY STATES

In the April—May reporting month the amount of traffic handled fell off about 40%. This is due to poor radio weather perhaps but mostly due to the warmer season which takes the gang out in the open and cuts down on the number of hours of brass-pounding each night. The percentage delivery figures remain almost as high as before.

The percentage of all the Official Relay Stations under each officer and the percent of TOTAL messages handled by each section are included in the summary of this month's work. By comparing each column showing these percentage figures the standing of each section is shown on a message-handling and reporting basis. If the percentage shown opposite your name under "CORS" is greater than shown under "MSGS" it means that some of the following things need to be done: (1) Dead O. R. S. need to be cancelled. More live stations need to be appointed. (2) Message lanes need to be formed covering your territory. More schedules may help. Perhaps the followings needs to be urged to originate more messages. (3) Maybe the messages are being handled all right after all but the reports are not coming in as they should—which means that some letters need to be written.

The different Assistant Division Managers are listed below. Are you doing your part to keep your State and Division a leader? How will you stand next month?

If every station owner who reads these words will see that every message he handles is delivered or passed along promptly and report his good work, we will be able to show 100% delivery in the National scheme of things in a short time!

The problem of message RELAYING and DELIVERY must get some serious attention if our general service is to be one of which we are proud. The reports show that messages going over regularly scheduled routes get through with the desired speed and 100% accuracy. The figures show that there is plenty of traffic to be handled. More individual responsibility regarding prompt relaying and delivery will bring the results we want.

Messages received should always be delivered immediately (a) by telephone, (b) in person, or (c) by mail if no other means of effecting delivery are available.

Never accept messages which cannot be handled or delivered without informing the chap filing the message of the circumstances.

Keep the hook clear by handling traffic on schedule daily.

ATLANTIC DIVISION							
State	ADM	%	%	Msgs.	Orig.	Del.	Total
W. N.Y.	C. S. Taylor	3.65	4.4	222	110	335	659
Md.	G. L. Diechmann	.81	.178	1	13	11	28
Del.	H. H. Layton	.17	1.12	45	33	96	176
D. Pa.	J. E. Rau	3.5	4.38	106	101	483	704
S. N. J.	H. W. Densham	1.39	.585	18	15	56	92
W. Pa.	P. E. Wiggins	3.9	5.12	76	80	638	802
		13.3	15.88	471	352	2119	2492

CENTRAL DIVISION							
Ill.	W. E. Schweitzer	4.87	7.16	108	295	513	1116
Ohio	D. J. Angus	5.74	2.17	32	10	86	341
Ind.	D. J. Angus	2.54	2.04	59	33	107	320
Mich.	P. D. Fallain	3.00	1.89	---	---	---	392
Kc.	J. G. Anderson	.93	---	---	---	---	---
Wis.	C. N. Crapo	2.66	3.28	237	161	176	514
		19.8	16.4	736	349	882	2583

DAKOTA DIVISION							
No. Dak.	G. R. Moir	.093	.045	1	2	1	7
So. Dakota	M. J. Junkins	1.45	.212	3	3	13	49
Minn.	C. L. Baker	4.5	3.27	158	102	264	514
		6.9	3.82	162	107	311	570

DELTA DIVISION							
Tenn.	L. K. Rush	.058	.28	15	4	25	44
Ark.	L. M. Hunter	.25	---	---	---	---	---
La.	C. A. Freitag	1.347	1.46	10	8	52	70
Miss.	J. W. Gullett	.297	.236	16	8	13	57
		1.24	.962	41	29	90	151

HUDSON DIVISION							
N. Y. C.	F. H. Mardon	2.5	2.23	228	113	245	606
N. N. Y.	H. N. Ammenheuser	2.4	3.88	146	78	386	610
N. N. J.	A. G. Webster, Jr.	2.8	1.23	12	18	134	194
		7.7	8.34	416	290	765	1310

MIDWEST DIVISION							
Kans.	C. M. Lewis	1.16	.80	32	7	87	126
Mo.	L. B. LaBure	2.02	1.21	31	17	95	190
Iowa	D. E. Watts	1.74	2.11	---	---	---	321
Nebr.	H. A. Nielson	1.16	1.73	34	56	157	273
		6.1	5.85	137	70	359	920

NEW ENGLAND DIVISION							
Me.	S. B. Coleman	1.56	1.80	191	37	382	752
N. H.	C. P. Sawyer	.87	---	---	---	---	---
Vt.	C. T. Kerr	.69	.886	55	27	57	139
Conn.	H. E. Nichols	1.22	.880	24	69	45	138
W. Mass.	C. J. Green	2.03	1.57	66	63	116	246
E. Mass.	Glady's Hannah	2.04	3.25	120	54	231	526
R. I.	D. B. Panther	1.16	.720	22	38	53	113
		9.64	12.2	461	367	984	1915

NORTHWESTERN DIVISION							
Wash.	Orro Johnson	.58	3.64	178	169	284	571
Ore.	A. U. Dixon	1.1	.955	29	18	112	150
Ida.	K. S. Norrwest	.46	.898	195	7	29	141
Mont.	A. R. Willson	.58	.56	29	11	47	88
Ala.	L. H. Nachin	.12	---	---	---	---	---
		4.00	6.05	592	145	472	950

PACIFIC DIVISION							
No. Sect.	L. E. Smith	4.58	10.06	351	358	771	1580
No. Sect.	P. W. Darr	2.56	1.885	62	167	203	393
Hawaiian	K. A. Canin	.58	4.50	538	104	65	707
		7.42	16.4	951	526	1003	2580

ROCKY MOUNTAIN DIVISION							
Colo.	C. R. Stoshman	1.45	3.44	89	51	400	540
Otah	Art Johnson	.63	.842	16	12	102	132
Wyo.	N. R. Hood	.18	---	---	---	---	---
		2.26	4.28	105	63	502	672

ROANOKE DIVISION							
No. Caro.	H. S. Morris	1.02	.944	17	56	100	153
W. Va.	J. S. Hoffman	1.9	3.15	91	58	146	445
Va.	J. P. Wolford	1.6	1.62	35	9	60	104
		4.5	4.79	143	84	506	752

SOUTHEASTERN DIVISION							
Ala.	H. S. Brownell	1.85	2.09	57	65	176	328
S. Caro.	A. Duppe	.25	.153	8	6	10	24
Ga.	J. Morris	.81	---	---	---	---	---
Fla.	H. J. Grogan	1.45	.21	6	10	17	33
P. Rto	Luis Rexach	.058	---	---	---	---	---
		4.4	2.45	71	81	203	385

WEST GULF DIVISION							
No. Tex.	W. R. Forrest	.87	7.08	56	27	48	111
So. T. ex.	K. A. Sahn	.87	.019	1	---	---	---
Okla.	K. M. Elbert	1.16	1.058	28	12	126	166
		2.90	1.78	65	29	176	280

PRAIRIE DIVISION							
Manager	F. E. Outland	.38	.708	---	---	---	---
ONTARIO DIVISION							
Manager	W. Y. Sloan	2.3	1.042	---	---	---	164
VAN-ALTA DIVISION							
Manager	A. H. Asmusen	.93	.322	21	15	24	60
MARATIME DIVISION							
Manager	W. C. Borrett	1.0	.558	28	22	3	53
QUEBEC DIVISION							
Manager	Alex Revell	.48	.140	---	---	---	22
TOTAL FOR COUNTRY							
Originated	Delivered	Related	Total				
1197	2435	8284	15,692				

KEGK, the Chantier, of the Byrd Arctic Expedition has been putting a powerful signal into the States almost every night. 8DAJ, 8DCW, 3ZS, 1BU, 9ABK, 2CLE, 8XD, 1AOQ and 3CA have reported copying the signals regularly. 2NZ, 1MY, 2AHM, 1CKP, 1CJR, 9BQA, 2HA, 8BF, 5ACL, 1ACI, 1ZD, 8EQ, 8CCI, 9BAS, 9WE and 2UO send in reports of having worked KEGK or handled traffic with her. At this writing the Chantier is half way across on her return to New York and just tears the phones apart. 2NZ handled a great deal of important traffic during the trip to Spitzbergen—taking between 800 and 900 words in messages. 1MY delivered 25 messages from this expedition while 1CKP took about 10. 2AHM piled up about 300 words during the return trip. Everyone who helped in maintaining communication deserves a lot of credit for the results obtained which we believe were highly satisfactory. Let's try to do as well for the other expeditions using amateur radio for contact. VOQ on 20 and 33 meters is Manley on the Schooner Morrissey of the Putnam Expedition which will have been out from New York about two weeks when this gets into print. More details about all the expeditions are available elsewhere in this issue. Don't forget to do everything you can to help maintain contact—and report what you do to A.R.R.L. Headquarters so that we can give you credit for your good work.

June 6 the Illinois gang staged a state picnic at Wilmington. The program included entertainment features, good talks by prominent radio men, and athletic events with prizes. A formal meeting was held at which the question of forming a state organization and having a convention was discussed. 9APY got out a bulletin to round-up the gang which turned out in full force. The traffic situation in the Chicago district was one of the live topics discussed.

6HJ put a bunch of traffic thru to the Wilkins Expedition. Over 35 messages were handled to 7SM at Nenana, Alaska in one month. The hook was kept clear of traffic so that none got more than 12 hours older during the transit thru 6HJ. As some of the messages contained over 300 words, this is a record worthy of duplication. FB! Yes, 6HJ uses a couple of UX210's and regular schedules to shove 'em thru. If you can do as well, let us know about it.

There are sometimes unavoidable errors in QST and usually they have a habit of landing on some unsuspecting and consistent amateur for one or two months in succession. 9BFG calls our attention to

the fact that in the QST's for Feb. 1925, Feb. 1926, and June 1926 we have his call wrong in the Brass Pounders' League so that someone else gets the credit. He is listed as 9BHF, and 8BFG, and 8BBG respectively. Mr. Eppa W. Darne of 8BWT recently made the starred rectangle but his name and traffic figures got considerably scrambled in the type-setting process. Sorry, OMs—we hasten to apologize for our mistakes. Let's hope there are no more as bad as these examples.

5AK is conducting some experiments with radio from his airplane as he travels around enticing sheekles from the poor unsophisticated public. If you hear 5AK on 20 or 40 meters between 5 and 6 a. m. MST drop a card to Mr. D.E. Slingerland, Las Cruces Municipal Schools, Las Cruces, New Mexico. 5ARN and 5AGU are assisting in the experiments.

3BWT has a record for consistency that would make anyone proud. His call has never missed a single night on the air for more than five years. Three transmitters are used, a "fifty" on 38.4 meters, two "fifties" on 82 meters, and two "fivers" on 177 meters for local work. The tubes blow once in a while from old age—not voltage breakdown.

6PW points out that many messages are being acknowledged improperly, that "R" is being badly abused. Often a station will come back with "R QTA QRM." Of course this is all wrong. "R" means that the complete transmission was received and understood perfectly. "R" means that the whole message was correctly copied. To acknowledge in this manner when asking for a repeat is worse than a double negative. If interference cuts off the request for a repeat, it appears that the message is OK and the transmitting station may sign off in error. Please watch this, everybody.

The eighth edition of the Rules and Regulations of the A.R.R.L. Communications Department is just off the press. If you are uncertain about the correct message form to use; if you don't understand how to sign off properly or to get "fills" in messages; if you want to know what qualifications you need to get an Official Relay Station appointment; if you want to understand the duties of the new Section Communications Managers, just drop a postal card to Headquarters and ask for a copy. It will be sent you without cost.

## DIVISIONAL REPORTS

### ATLANTIC DIVISION

**WESTERN NEW YORK**—Traffic shows a wonderful increase. Foreign work has taken a great jump, too. Credit goes to 8ALY, Rochester, N. Y. for working no less than 39 foreign countries. 8DXX has been reported in Switzerland. He handled a 100 word message from 1LJ. 8DDL with one UX210 worked England Porto Rico and all U. S. districts. 8BSM on a UX210 worked all U. S. districts. 8BSF was heard in South Africa. 8NT is keeping schedules with a's and z's while 8AVJ was heard by 'em. 8NT handled traffic with the Detroit Arctic Expedition. 8BZU worked more foreign DX than we can name here. 8QB was QSO z's while 8UL worked 88WW and 85TD. 8ARG worked 8BOC and S-SGC was a UX210. 8KW has an appointment in 98th Div. A-A radio service. We need more like 8KW. Wake up, fellows. Stations all over Western New York are needed. 8ABX is back at WJZ and will probably open up a set in the 3rd district. 3AGU wants schedules with amateurs in Syracuse. Gloversville has five new stations working on 80.—8APK, 8ATF, 8BML, 8CIV and 8CBS. The latter is planning a trip to Calif. in July. 8DBQ is changing over. 8ALH is back again. Welcome. 8DXX leads the traffic this month, thru his many daily schedules. 8DKN also keeps schedules. 8AIL has an ORS in store for him. 8CNT is now handling traffic. 8QB has rebuilt his station and reports PRR tests very successful. 8AIL handles traffic now. 8DPL has schedules with 8DSI, 8AVH, 8DSY, 8AHK, 8RKM, 8ITZ. 8BQK handles traffic in good style. 8DRJ is

hitting the traffic list strong again. 8DKN has daylight schedules on 40. 8VW and 8HJ still handle their share. 8BHM also is a traffic-handler. 8BKG is a new station which promises to be a hummer. 8BCZ keeps schedules with 2AKV after 2AM each night and handles his traffic regularly. 8ACH is back with a 201A. 8CVA does well on 40. 8CVP is back to 80 meters again. 8BFG uses a fiver on 40 and 80. 8ZU is off account of OW and school. 8ADM is QRW heavy work although he managed to handle traffic with ANK in the Sahara Desert. 8ABS states a Raytheon tube will handle 500 volts with overheating, using it for rectification full wave. 8BSF has a schedule with a yacht on Atlantic Ocean for the summer. The Rochester Gang swooped down on the ADM and a good time was had at several ham stations. 8PJ was heard by a Frenchman. He has been handling traffic of convention news, etc. 8RV was QRW business so neglected to report this month.

Traffic: 8DME 31, 8CZP 17, 8CVJ 18, 8ZU 8, 8ADM 12, 8DDL 16, 8AYB 7, 8DXX 231, 8NT 22, 8CNT 2, 8QB 15, 8UL 18, 8AIL 2, 8ARG 23, 8DPL 51, 8CNH 1, 8BQK 20, 8DKN 36, 8HJ 2, 8VW 10, 8BEM 26, 8BCZ 7, 8DRJ 25, 8ABX 6, 8PJ 38, 8DSI 26.

8DXX made the Brass Pounders again this month—why not more Brass Pounders? 8FP is now at WAM and will welcome any ARRL visiting hams. 8DPL is now in the USNRF.

**EASTERN PENNA.**—Dist. 4—GM Bell reports 8EU busting thru QRN with his new Mercury arc rectifier. He lost his last 50 watt and a few meters with it but is now back. Hard luck after month's pace OM. 8AVK got a new 100 watt rig with MG on 75



meters. 8CMO lost three fivers last month. 8BFE's junk went on the rocks and Bell is rebuilding.

8BIR fusses around getting a new 50 working. 8AHO gets out FB. 8BSZ moved. 8CPT is off due to school QRM. Business kept 8BIT off this month. 8AFR moved to Hazleton. 8RQ is busy at WCJ. 8BQ the same! 8AFR pounds brass at WCJ along with 8RQ and 8BQ.

Dist. 2—8RNU has again started up with a new 203A tube using 20, 40 and 80 meters. 3RLC is working FB on 40. 8AVM was inactive. 3LK complained that his last report missed QST—the fault didn't lie with the DS tho. How eum 8AVL and others—no report? The DS was mighty sorry not to have better cooperation in reporting this time. He has worked diligently and unceasingly for the gang. Now he asks you to cooperate fully with Herb Wallez, 597 No. James St., Hazleton, Pa. who is the new SCM all of us in Eastern Pa. report to on the 26th of each month. 8AWT blew his 202 and is now using a 210. He promises to be in on good shape next month. 8AY is using 2 UX210's and has gone to 37.9 meters. 8JN has been trying 20, 40 and 80 meters. He reports 8AJC as a new ham and a good prospect. 8LW worked 83KB, 8IANO, 8AD, 8FUH, 8ATM, and 87HL during the month. 8ACY keeps schedules with 2WC and 2CP. His QRH is not 40 meters as May QST stated but 79 and 82 meters.

8AUV changed his Hertz antenna to a two wire r.f. feeder inductively coupled to the antenna with much better results. 1ACB, formerly of Mass. has moved to York and will assist 8BVA at his station this summer. FB. 8BQP has worked very fine DX, keeping a schedule with 88NX nightly at 6 pm EST. Who knows the QRA of "E48"? 8ZO has daily schedules with 5ZAZ, 8GZ, 8PL, 8AUV and 9ZA. 5ZAZ is on a ship bound for Holland and Germany and has, thru the courtesy and consistency of 8ZO, been able to keep in touch with the home folks. 8BVA keeps a schedule with his girl every night at 8 pm. He will be on regularly after June 15, tho.

Traffic: 3LK 16, 8AWT 1, 8AY 12, 3JN 9, 8LW 7, 8ACY 18, 8AUV 67, 8BQP 4, 8ZO 130, 8FS 5, 8DSI 26, 8EU 227, 8AVK 12, 8CMO 11, 8AFR 3, 8BSZ 4, 8AHO 102, 8BIR 3.

MARYLAND—8OP on 40 meters, worked Z, BZ, G and Hu stations. FB! 3RF has been doing consistent DX with a UX210. 3CGC is perking FB. 3OU is at last on the air and QSO three stations. 3SQ, an old timer, is on with a lone fiver on 40. 3AOJ did some nice work with his ancient 202. 3PH is installing a Mercury-Arc rectifier. 3PH and 3AIB are getting many foreign reports. 3AHA has been QSO Europe and NZ consistently. FB, OM. 3LL moved again. He is getting out fine now. 8VI and 8GT use both 40 and 80 meters. 8QJ sticks to 80. 8WF dropped from 180 to 40, and works every station called. 8HP and 8WA are on consistently and reach out well. 8AEA is rebuilding and is an op at WBAL. 3PU is now going strong on 80. 8APV is busy writing a 10,000 word thesis on Mercury Arc rectifiers. 8SF is still experimenting with indoor antennas and collecting data on heat-losses in transmitting inductances. 8BMO is not on much. We suspect he has left the comic urge. 8PS keeps things humming in Annapolis. 8BUR is busy with studies at the N. A.

Traffic: 3RF 4, 3CGC 4, 8GT 2, 3HG 13, 8APV 5.

DIST. OF COLUMBIA—A most notable event this month is the revival of some honest-to-goodness ham phone sets. 8BWT, 8ACM, 8JO, 8ASO and others have erected phone transmitters of low power operating in the 200 meter band and every evening work among themselves and similar stations over distances up to a hundred miles. These sets sure seem to bring the old "get together" spirit back. 8BWT blew a couple more fifties, making twenty-nine in three years. 8HS shoveled the dust off the key, worked a station in Algiers and concluded there's something in radio after all. He's back for keeps now. Another new station has started up with the call 8RN. Good luck to him.

Traffic: 8ASO 16, 8AB 15, 8BWT 107, 8BKT 27, 8ACM 9.

SOUTHERN NEW JERSEY—Dist. 1—Interest seems to have fallen off considerably this month. 8XAN is keeping regular schedules twice a week with 2SC at Governor's Island, N. Y. Regular contact is also established with 8QL at Syracuse, N. Y. 8ZI, the alternate station for the Governor's radio net, has built a complete new 80 meter transmitter for A-A work. At present, 8XAN has schedules with the HQ station

## CENTRAL DIVISION C. E. Darr, Manager

O HIO—Dist. 1—8CVO, an old timer, has made application for ORS. 8BN says the Hertz antenna is FB and works better than any. 8LO is now on 80 meters.

Dist. 2—Very little traffic was handled this month as most of the stations were off the air the entire month. 8ZE is on, and worked Australia, Tasmania and Hawaii. 8RY expects to make a trip near the Equator for the Tropical Radio Company soon. 8AGS just returned from a radio school with a commercial first and will be on the lakes for the summer. 8CTE and 8CJM have combined stations and are busy getting things in working order. 8BXQ and 8BKQ are still off the air. 8BCE will be on regularly now in the early morning.

Dist. 3—8BTH continues to handle considerable traffic. 8BPL has been QRW business but takes time to work a few of the boys in South America and Australia. 8DIA was away on business all month, hence no traffic. 8TT left the YLs early a couple of nights and managed to put over 10 messages. 8DKW has no aerial at present and says the DX isn't so good. 8ACY has returned to the op's job on the lakes and now signs KFNN. 8DRX is the only man in Youngstown to report this month and has been having trouble with bad power leak. 8BKM has been on the lakes but slipped home long enough to get a message total of 24.

Dist. 5—The DS takes traffic honors again, altho his station wasn't on much. 8GZ is not very active and we think his YL has him hog-tied. He is now QRW Aussie Tests. 8BYN will soon be on regular again. 8PL also was off the air and reports as safely on again. 8CBI has become kind of sluggish with warmer weather. 8BBH is still trying to make a Hertz work. 8DSY is active and down on 40 for the summer. 8BNA is in the 4th district but sends his report to the DS because the 4th doesn't get into QST. 8DEM lost his pole and mast. 8ADH sent in an application for ORS along with 8AHH a few months ago but hasn't heard from it yet.

Traffic: 8AOE 8, 8DCB 1, 8BSA 6, 8AVX 4, 8CVO 6, 8BN 7, 8ZE 14, 8DRX 24, 8BPL 24, 8BKM 24, 8TT 10, 8GZ 56, 8PL 1, 8CBI 9, 8DSY 15, 8BNA 19, 8DEM 3, 8BYN 72, 8ADH 38, 8LO 3.

WISCONSIN—Dist. 1—8DTK is giving 9CM at L'Anse, Michigan daily baseball scores. 9ATO is doing good work in the Army Reserve net. 9BKR thinks he will close down for the summer. 9BWO is still operating on storage B's. 9CIB hopes to have the crystal oscillating soon. 9COT has given up trying to work on 40 until he gets enough ambition to climb around on the roof and put up a new antenna. 9AFZ says he has plenty of time but spends most of it at Gimbel Bros. 9EHM is under construction and expects to be going in a month. 9BTK has been sick with the mumps. 9VD busts out on 39 and 78 occasionally and busts in at the neighboring BCLs.

Dist. 2—8EK—9KH is operating with crystal control on 38.42 meters. 9BIB is using crystal on 40-2. 9EAR is on 38 m. and building a short wave portable for summer. 9COI is so busy at school he can't find time to pound brass. 9AZA wants it known that he is not dead but only dormant.

Dist. 3—9BZA sends report only, with no station news. 9AGV lays his low message report to poor conditions. 9EMD has all his equipment for a 50 watt but 4000-1 "S" tubes. 9AZY is QRW school work and track practice. 9ANE has become a member of the M.R.A.C. 9CXX is looking for stations to carry on schedules during the Eagle Convention June 16 to 19th. Address H. J. Fischer, 201 E. Mill St., Plymouth, Wis. 9BVA is QRW spring fever. 9DCT has just finished three month's school for a commercial first grade license.

Dist. 4—8AZN and 9ZY have been appointed Army Amateur stations. 9ZY is building his transmitter now. 9BLF will handle all traffic from Camp Sparta this summer to LaCrosse. 9DCX and 9EIK are rebuilding, also.

Dist. 5—9ELI has schedules with 9XI-9XM daily. Traffic: 9DTK 194, 9ATO 83, 9BKR 24, 9BWO 11, 9CIB 8, 9COT 3, 9AFZ 2, 9BTK 23, 9VD 7, 9EAR 2, 9BIB 5, 9EK 81, 9BZA 17, 9AGV 15, 9EMD 12, 9AZY 5, 9ANE 4, 9CXX 2, 9AZN 44, 9BLF 20, 9ZY 2.

ILLINOIS—Dist. 1—9BHT is rebuilding. 9DGA has an H-tube. 9BIZ installed a motor generator.

Dist. 2—9DZR is going back to 150 meters. 8RQ is on regularly with 4 operators. 9ALF works daylight on 40 and runs a broadcast station evenings. 9ELR divides time with the YLs. 9AWT's aerial blew down.

9AJM is building a 20-meter set. 9BRX is operating as usual. 9BVK is going to move to California this summer. 9ELF reports traffic scarce on low waves. 9ARM is temporarily off the air due to outside duties.

Dist. 3—9AHJ is off the air due to spring fever. 9CSW can't find any traffic.

Dist. 5—9BPX keeps schedules and reports everything going along like clockwork. He has all the fellows in town interested in ham work now. 9DBI has schedules with 9CYS on Monday and Thursday.

Dist. 7—9DPL worked France and Australia handling traffic with one lone UX-210. 9VJ blew all his tubes. 9ALJ is looking for reliable schedules on high waves. 9CSL is trying to get more recruits for 150 meters. 9AFF junked the tiver for a fifty. 9AIZ says the Hertz is the thing. 9CJ is selling out. 9EJY is busy experimenting. 9DAF reports things in general in bad shape. 9DYD is trying to increase power. 9NV has a 250-watt fone set on 84.5 meters. 9IX is busy with the new flivver. 9DXZ is a new schedule station and operates well. 9KC and the gang are trying to organize Illinois into a better working machine and revive the old spirit. 9BHM has had trouble getting the set to perk ever since he moved.

Traffic: 9IX 154, 9APY 121, 9NV 100, 9BNA 80, 9RK 53, 9QD 52, 9RVP 46, 9CEJ 39, 9DWH 38, 9DXZ 31, 9CNB 28, 9EFP 25, 9AFF 24, 9AAE 23, 9DYD 23, 9AAW 20, 9AGW 20, 9CSB 20, 9PU 19, 9RQ 19, 9AXF 18, 9FJ 18, 9ALK 16, 9DOX 12, 9DXC 11, 9DZR 10, 9AIZ 9, 9BPX 9, 9DAF 9, 9EJY 9, 9VJ 9, 9DDE 8, 9DLG 6, 9ALJ 5, 9BWL 5, 9CSL 5, 9ALF 4, 9ALG 4, 9BBA 4, 9DXG 4, 9AHJ 3, 9AWI 2, 9RFH 2, 9ELR 2, 9GE 2, 9DQR 1, 9EKD 1, 9DBI 8, 9BHM 5.

MICHIGAN—Dist. 1—45 messages were reported from about four stations. A few reported no traffic handled. No news items have come in from the stations except 9CM in Upper Michigan who says his new H-tube signed off. 9AMS comes thru with a report and a little advertising matter for his neck of the woods. FB, OM, we admit you have a fine place in the summer. 9CCW sends in a report this month after a silence of nearly a year. 9ZH is spearing around the wave channel under the call 8XAZ, let's hear reports on it gang. 9EKG is a new station. 9CJT finally was reported R5 in London.

Dist. 4—9BC desires schedules with Chicago, Milwaukee and Detroit. 9QN is operating on NEU, USS *Dubuque* of the Naval Reserve. 9EAY and 9CE are working on schedules.

Traffic: 9CCW 14, 9ZH 10, 9ACU 9, 9EAY 3, 9DSF 9, 9BC 49, 9CEP 96, 9AIS 24, 9ZZ 12, 9CJT 21, 9CM 45.

INDIANA—Dist. 1—Ft. Wayne—9QR finally tuned the set up so as to produce a DC note. 9BKJ is bothered with violet-ray QRM but keeps up his skeds and tfe. 9DPJ has the first pipe antenna in this locality for 40 meter work. 9ARH is on again with a new complete equipment. 9CIE is a new ham but we have no particulars yet.

9CNC is operating the BCLs delight—WHBU—in addition to operating his station. 9BCM has moved and now has his old veteran UX-210 on rag and 80 meters. 9DPI reports 250 miles on 3 UV-201As and 200 volts B battery. 9BNP is on with a new H tube and 1200 volts from motor-generator. 9RQZ just started up with a 5 watt. 9CNC worked the west coast on 40 meters.

Dist. 2—9CUI is on 40 now with a five watt. 9ASN has rebuilt and is going after an ORS soon. 9DDZ moved and will be on with 150 watts on 40 meters. 9BWI is cussing the hill that interferes with his DX. 9AMI replaced his 800 volts CRAC with 45 volts B-battery. 9CCL is using his antenna on the ground in the yard for medium distance work. Very medium. 9ASX is trying fone. That's as far as he gets. Code FB. 9BMT can't get his rectifier to work on 80 or 40 meters. 9BO uses a receiver but no transmitter. 9BBJ blows his plate condensers with his 250 so can't transmit. 9BSK is using 7½ watts on 20 and 40. 9APT is on using a 5 watt. 9CP is working the foreigners with a Marlo sync. The Indiana State ARRL Convention will be held in South Bend, July 30 and 31.

Dists. 3, 4 and 5—The Radio Inspector cleared out a few at Evansville and the only survivors are 9KG, 9BSC, 9AHM, 9NG, 9EBW and 9ELV. 9AHM has a new antenna. Has just got out of the hospital. 9NG is QRV business. 9BSC is now operating on board lack steamer Britt, KFNU. 9CPI just started up at Terre Haute. 9CMJ is on with a new transmitter. YLs bother his DX some. 9EBW blew his power transformer and is putting in a motor-generator. 9CSC landed a job so will not be on as much as he was. 9WC is rebuilding. 9CMQ is getting out good

with a 50 on 40 meters. The Indianapolis Radio Club just started through a new class of 12 BCLs in code, to become future hams.

Traffic: 9BRG 5, 9BKJ 54, 9DPI 45, 9DRS 4, 9QR 3, 9EJU 49, 9DPI 5, 9RQZ 1, 9CNC 12, 9DYT 19, 9BYT 18, 9DHJ 15, 9AEB 4, 9ABI 2, 9BSK 15, 9DDZ 3, 9CP 17, 9ASN 3, 9BWI 18, 9DVE 3, 9BBJ 1, 9AMI 5, 9CCL 2, 9CSC 21, 9CMJ 4, 9CMQ 4, 9CPI 1, 9EBW 17, 9NG 10.

KENTUCKY—9AMJ will be off the air a few days because his pole is getting weak. 9BPD has power from 1-KW on down! 9EI at least has a rectifier that he thinks might work. 9HP continues to work the world with a 50 on 40 meters. 9CTE is about the only Louisville station on 80. 9MN is on 40 most of the time.

#### DAKOTA DIVISION D. C. Wallace, Mgr.

THE present Division Manager takes this opportunity to thank the ARRL members, the officials of the Division and the ORS for their splendid support during the past three years. It has been a pleasure to work with you. I feel confident that under the new arrangement, even more can be done.

June QST carried the notice of the sectionalizing arrangement for the division. There are 4 sections and we have until July 15 to get nominating petitions for our new officials into Hartford. Better get busy and send them along right away, OMS.

SOUTH DAKOTA—Dist. 1—9CKT will have the regular set at Madison and a DC portable for road work on the air. 9DIY is working daylight DX on 40. Sioux Falls is again coming to the front and now has three active stations with two more in sight. 9DNS is the station of the YMCA Radio Club. 9AJP is on the air. 9AIN lost his antenna and is rebuilding the entire set. 9CKT lost his antenna, also. 9DDH will close for the summer soon and the ops will take over their private station work again.

Dist. 2—9DWN will be on as soon as school is out. 9DZI has been off due to rectifier trouble. 9NM still keeps his west coast schedules. 9DB received a report from Belgium on his 80 meter fone. 9CBF will be on again shortly in Minnesota.

Traffic: 9DIY 2, 9DZI 11, 9NM 5, 9DB 10, 9RBF 4, 9RKB 3, 9CJS 14.

NORTH DAKOTA—9CZG pounded out a few messages in spite of the spring fever. 9CRB still sticks to 178 meters and kept schedules with 9AMQ and 9AC. 9BJY has installed a 50 watt but is bothered with power line QRM in dry weather. 9BQD is kicking out well with 3 201As. 9CCT is in California on his vacation. 9DKQ has a new radio shack in the form of a filing station. 9EFN is still on 80 meters but will be on 40 for the summer.

Traffic: 9CRB 1, 9DZG 6.

MINNESOTA—Dist. 1—9KV is working out very well and added England, France, and AQE to his DX list. 9EGU is undergoing some rebuilding but is on the air with fair regularity, however. 9DKR is pounding away as usual and gets both coasts very easily. He handled some important traffic to Omaha. 9AOG is back from the west coast and is on 38 meters with a small set.

Dist. 2—9BIY continues to handle good traffic and is high man this month. 9MB, 9EGG and 9COF were too busy to be on the air much. 9BKK keeps schedules with 1BBJ. 9COS changed to a single wire antenna, but results were not so good. 9BNF is busy handling Army traffic and is experimenting with low power work. 9GZ wants schedules with some Twin City station. 9DBW has a real rectifier and gets a steady DX note again.

Dist. 3—9DWO is reported RS on both coasts. 9DGE left town to do surveying work for the government. 9DHP works out well with a UX210, sneering both coasts all the time. 9BNE works all the USA with his 7½ watt. 9ZT worked A or Z 12 mornings successively without a miss on 89 meters crystal control sometimes. 9BMX, 9ASW, 9DYZ and 9BVH are QSO Australia regularly. 9BAY is building a 1000 watt set at the army at St. Paul. 9BVH, 9BMX and 9ZT were visited by Australian 30M 9DEQ now uses a Zeppelin antenna with great success. 9DNX is on again with a UX210; FB.

Traffic: 9CKI 18, 9EEP 22, 9DKR 5, 9KV 55, 9GZ 9, 9BNF 25, 9SF 2, 9DBW 37, 9BBV 3, 9BKK 10, 9MB 4, 9COS 4, 9BFC 20, 9BITY 44, 9BVH 9, 9DPX 27, 9CUM 4, 9DYZ 2, 9BAY 19, 9ARK 14, 9ECC 33, 9CPM 45, 9BIS 6, 9DGE 10, 9DWO 4, 9ZT 39, 9BNE 23, 9DHP 8, 9GH 2, 9IG 21.

**DELTA DIVISION**  
**B. F. Painter, Mgr.**

**T**HE Louisiana ADM writes that he has never seen such heavy static and weather conditions. It has completely stopped work in his state. This partly explains the reason the Delta has dropped off so lately. We are missing the reports of the Tenn. and Ark. ADMs, who seems to have entirely disappeared.

**MISSISSIPPI**—5AQU is experimenting on 20 meters and says FB. He had school QRM. 5ANP had two storage batteries go dead on him and is off until he can get more. 5FQ is on 80 meters and threatens a 250 watter soon. ADM 5AKP had a lot of trouble. A bad rectifier or broken counterpoise, a dead battery, and death in the family make us all extend condolences to 5AKP. 5ANJ has almost given up with disgust due to the heavy static. 5QZ reported for 5ARB this month.

Traffic: 5AGS 6, 5AKP 14, 5AQU 7, 5QZ 10.  
**LOUISIANA**—5KC uses 2 UX210 tubes and Gem dollar tubes. 5ACY is doing fine work with his H tube every night. 5AUH is back also with Gem tubes. He expects to handle lots of traffic. 5ANC is the most modest ham of the bunch. He averages about 20 messages but never says anything about it. 5AGJ has an 80 meter fone but gets time to handle a few.

Traffic: 5ACY 16, 5ANC 15, 5AGJ 8, 5ML 5, 5EN 9, 5UK 12, 5KC 5.

**TENNESSEE**—4HL at Memphis uses a UX210 and worked Hu8BDD May 8th. This is a blamed sight better than the DM does with his 250 watter. 4MM (X-5ANT) will take a portable transmitter while attending the Army camp at Ft. Bragg, N. C., this summer.

Traffic: 4HL 7, 4MM 7, 4EE 14, 4HP 5, 4FP 11.

**HUDSON DIVISION**  
**E. M. Glaser, Mgr.**

**Q**UITE a few ORS certificates have been issued lately by the DM and the number has exceeded all previous records in the division.

The DM has been active in the TD for five years, having held every possible office and feels that he doesn't want to run for Section Manager in the new elections. There are others in the game who have more time to devote to this interesting work than has the DM. 2BRB has a strange desire to be heard on the air a good deal more often than during the past year, too and this will be possible only by a let-up on the correspondence handled. Glaser will do all he can to help the new personnel and will play a more active part on the air.

Dave Talley, 2PF, wants more applications from upper and Western N. Y. for the Army-Amateur work. There is a lack of stations from many towns where there are army units. Better get your application in today, OM.

**NEW YORK CITY**—Bronx—2ALP steps out in fine shape. 2APV handles much European traffic and has schedules with NTT and f8YOR. 2ASA finds traffic on the increase. 2BBX must be QRW YLs. 2CYX carries out a lot of foreign work, some on schedule.

**Brooklyn**—The report is small because of a change in the City Mgr. AR stations are requested to report to 2PF, 3222 Avenue O on the 15th. It is rumored that 2UD is tired of playing around non-oscillating crystals that he carries around with him and is going back to the ole set. 2BO is still pounding away on 40. 2EF is busy getting his station in shape for a good DX summer and a lot of schedules.

**Manhattan**—ZNZ is the star station and has schedules with KEGK and "CA" at Halifax. 2AMJ is working a bunch of foreigners. 2AZM is a new station—the American Sales Co. 2ALS is the head station for the Army work in Manhattan. 2EV has changed some things around the station. 2KR is alternate for 2ALS in the army net. 2LD has a good wallop. 2BE was at the convention and pounded brass at 2CHK. 2DI was married April 14th.

**Queens**—2AEV and a few Astoria stations are very active. All Queens stations are requested to report to 2AEV, the new CM.

**Richmond**—2AKK blew his bootleg 5er and is off the air. 2CLF has finally made his appearance. 2ATQ is handling a little traffic. 2AFV is doing most of the work in the boro and has been experimenting with 40 meter antennas. 2AKR with 2CEP operating at times, has some schedules and handles a good bit of traffic. 2CZN still bats some out.

Traffic: 2ALP 49, 2APV 32, 2ASA 55, 2BBX 51, 2CYX 65, 2BO 15, 2PF 1, 2BRB 3, 2CHK 4, 2AMJ 19,

2BNL 4, 2LM 8, 2LD 20, 2NZ 116, 2EV 20, 2KR 27, 2APJ 30, 2AZM 6, 2ALS 3, 2AKR 25, 2AKK 6, 2CZN 16, 2ATQ 3, 2AFV 32.

**EASTERN NEW YORK**—Dist. 1.—2AKV has been away but returned in time to keep schedules with FTS handling United Weather Bureau traffic. 2AJE rebuilt and is now using a 50 watter. 2BFB reports no traffic and expects to close down for the summer. 2AWX is using a 201A with 100 volts DC and has worked 600 miles and handled 30 msgrs. 2AWQ has been recommended for ORS. 2KX is getting ready to close down for the summer but will have his station, 2LS, on the air.

Dist. 2.—2DD has gone down to 20 meters to take advantage of the extra daylight saving time. 2AAN bought 2DN's old jitney and is running wild. 2CIL is in Italy learning to bend spaghetti. 2ASE has had to take it easy as the folks are beginning to kick. 2CTF is building a low powered transmitter for the George Palmer Putnam Expedition that will use Eveready B batts. 2CGB is engaged and says the OW doesn't want him to have a set going.

White Plains—2CNS has nothing very exciting has happened altho he has worked the coast. 2AAZ reports much QRM from school but has probably blown his usual quota of 201A's. 2BQB is also QRW school and "so forth."

2LA says a radio club is being organized in Larchmont. FB. Things have been pretty slow at 2LA. 2ALT is on the air in Pelham with a fiver. 2QU is on in New Rochelle on 40 meters and 2AVK, a newcomer, is on 180 meters. 2APQ has gotten started at last on 40. Having been on the air about four years, 2BOW has decided to report each month and wants to be an ORS. Another foreign country heard from! 2AWZ opened up with a 50 and is smearing 80 meters with a couple of S tubes. 2APT reports more traffic than the rest of the district combined. He says a new ham, Paul Leonard, has opened up in Poughkeepsie.

Dist. 3.—2SZ reports bad receiving conditions, due to power leaks. 2CDH is selling out but he'll be back stronger than ever before long. Hi. 2CTH says he is too sleepy to get up and work Australia. 2AOL has reached out to Porto Rico with his 5er and has worked as far as southern Georgia at noon time.

Dist. 4.—2AKH is still on the job when he gets time to operate. 2CYM has been very busy so did not do much this month. 2AGQ is on same but pretty busy. 2MK is still doing some fine DX. 2AOK is off the air for a while. 2COV is out of town most of the time. 2AJO is on 20 meters and finds it easy to QSO the gang. The ADM request all stations in the 5th district to send reports to him direct until the new system is put into effect. His new QRA is 315 Second Ave., Albany.

Traffic: 2AKV 5, 2AJE 101, 2AWQ 13, 2AUL 15, 2KX 6, 2AWX 30, 2SZ 1, 2AKH 6, 2AGQ 13, 2APT 190, 2ADH 85, 2BQB 18, 2AML 8, 2BOW 8, 2CNS 5, 2AAZ 4, 2AJQ 2, 2LA 1.

2BOW, 2ATQ, 2AAN, 2ASE, 2ADH and 2APQ all want appointment as Army Amateur relay stations.

**NORTHERN NEW JERSEY**—No traffic report was received from DS 2CJX and until further notice. Dist. No. 1 hams please mail reports and notes to 2WR, the ADM. 2WR has been appointed net control station for the 78th Div. Organized Reserve. 2KS is off for an indefinite period due to a death in the family. We all send our sympathy. 2CQZ is maintaining nightly schedules with pr4KT and 6BVG for traffic. 2CPD reports he attended the 1st Dist. Convention and had a WOW of a time. 2FC has renewed his operator's license so will be back on the air. Dist. No. 4 amateurs are failing to report and 2FC needs your support. 2ALW has schedules with 3UR and is in line for an ORS. 2CY is planning a super crystal-controlled station for work with the American Legion when that outfit goes to Paris. FB, OM. 2ALM is changing the QRA of his transmitter. 2BTR rebuilt his transmitter on a frame which looks very commercial. 2JC has not been in operation due to members taking out various pieces of the transmitter which they had only loaned. Hi. 2EY still sticks to 176 meters. 2BW works European stations daily. 2AVK and 2AVO are new stations in Woodcliff. 2CH, an old commercial op, is applying for an ORS. 2CDR attended the Atlantic City Convention and saw how the BCL's put theirs over. 2AFG, 2AVQ and 2GV all keep Newark on the map with their 80 meter fones.

Traffic: 2BW 5, 2CY 3, 2DX 5, 2KS 8, 2AEY 2, 2AHK 18, 2ANB 7, 2ARC 19, 2CDR 1, 2CPD 16, 2CQZ 18, 2CP 44, 2GV 21, 2ALM 10, 2ALW 6, 2AOB 4.

**MIDWEST DIVISION**  
**P. H. Quinby, Mgr.**

**Y**OUR DM wishes to thank you all for your excellent cooperation in putting this Division near the top. He hopes you will continue to give your hearty support to your new SCMs, enabling them to keep each state and section in top notch shape for years to come.

Your Director will still be on hand to care for any difficulties outside the province of your new Section Managers. Any of your League officers will be glad to hear from you at your pleasure, whether you have something on your chest or not. Above all, remember our numerous activities, participate as much as possible and be sure to let everyone know what you are doing through your monthly reports, if not oftener.

**IOWA**—9BZU and 9ACH have been out of the city. 9BOG is unable to be on due to outside work. 9CSY had trouble filtering his "sync." 9AJL has been on 80 and FB for traffic. 9APM was busy with outside work. 9EFS attended the Ames Convention. 9CWG kept busy at school. 9DJA got QSO on 42 at last with only 1 1/4 volts B battery. He calls for help. Hi. 9DSL came through. 9BZE states that the Profs are shoving them into the stretch. 9DAU was reported by r's and a's. 9CGY is QSO on 80. He worked 38% of the stations called. 9AXQ is busy checking off-wave stations. 9AXD did well even with a low B bat. 9BCD reports zero traffic but that he has slipped the ring on her finger. 9HK shot a number through. 9CS handled a bunch with his infernal CW (as he calls it). 9DOA took care of still more messages. He reports ham radio picking up around Tipton. Traffic honors go to 9CVE with 142 msgs.

Traffic: 9EFS 26, 9CWG 1, 9DSL 6, 9BZE 2, 9DAU 5, 9CGY 9, 9AXQ 1, 9AXD 8, 9HK 6, 9CS 7, 9DOA 39, 9BDH 28, 9CVE 142, 9AJL 19, 9BWN 7, 9APM 2, 9AED 6, 9BOS 10, 9DMS 7.

**NEBRASKA**—Dist. 1—9DXY doesn't seem as regular as usual. 9EW did good work with a 210. 9BGK secured a portable license to use while away. 9DPS and 9BNU promise activity soon. Three new stations are 9EGY and 9EEW at Alliance and 9CLA at Ft. Calhoun. Hope to have reports from all three soon. Luck, fellows, and let's hear from you.

Dist. 2—Reports were received from 9CEN and 9BQR. 9CEN is doing well with a 201A with about 200 volts on the plate. 9BQR is having trouble getting down to 40. 9DI says his total will increase with the closing of school. 9CBK is building a vibrating rectifier for a large tube. Good luck, OM.

Traffic: 9BFG 191, 9DUH 31, 9DR 25, 9CGS 6, 9DI 16, 9CEN 4.

**KANSAS**—9CKY has a new plate transformer, a 32 jar rectifier key filter and a better filter system. Edna Denton of Syracuse Kansas is a new YL who will be on soon. 9BHA lost his tube but will have a new one soon. 9BLB is still pounding the brass. 9AEY lost both fifties so will QRT a while. 9BGX uses 40 but is not on regularly. 9DRD QSO west Aust. 9DNG is showing 600 watts through a super sink into a 50. He kept schedules with several Aussies and added three new countries making 48. 9CVL has his H tube feeding a fourth foot vertical antenna and works the coast easily. 9CCS received reports from several S. A's, A's and g's. Ex9ACQ lost out as he couldn't get away to St. Joseph, Mo. for the exam.

Traffic: 9CCS 11, 9CVL 37, 9DNG 35, 9DRD 6, 9BGX 10, 9BLB 3, 9CKY 24.

**MISSOURI**—Traffic has had to take second place at many stations from a variety of reasons; the usual commencement of summer, QRN, school commencements, rebuilding of stations, business interests and a few instances of sickness. Only a few stations are at all consistently workable through the continuous QRN after sunset. Reports this month were obtained only after a resort to last minute appeals by mail and over the air and are only fragmentary at best.

Dist. 1—9BEQ has put a crystal into operation and next plans for using it on a jug. 9ZK had bad luck burning out his power transformer again after repairing a previous burnt-out. 9PW is setting up a low power set using receiving tube and B battery. 9DXN and 9DLB are shut down. 9AOT is active. The gang staged a visit to Kansas City, spending two days there having a general hamfest.

Dist. 2—9CDF kept sched with 9BYQ, 5AMN and 9ACA on 40. 9ARA and 9CVY are putting a 203A on the air in Butler. 9CVY worked CH. O and Tahiti. 9DNO left the district and is now 9RS in Washington, D. C. 9DIX is home from school and

promises msg. totals next month. 9DNJ was out of town installing a 100 watt at 5AOV. A code class is going in Holden, home of 9DNJ. 9DJI helped boost the msg total in Carthage. 9BSE reports no traffic but a large kick against bum fists.

Dist. 4—9BOZ is talking of getting back on the air. 9ACA and assistants are trying to pep up the club to carry on during the summer. 9ZD is installing crystal. 9ACX has been on occasionally but no traffic. Several ham trips have been under consideration by the K. C. club. 9BKK is now in New Orleans or perhaps on board ship, nothing heard from him for sometime.

Traffic: 9BEQ 25, 9ZK 10, 9AOT 12, 9DVF 7, 9BUE 9, 9LJ 20, 9ACA 5, 9ZD 5, 9RR 8, 9CYK 2, 9AJW 53, 9AQB 17, 9CDF 7, 9DJI 10.

**NEW ENGLAND DIVISION**  
**T. F. Cushing, Mgr.**

**W**ESTERN MASSACHUSETTS—It's necessary every so often to reprimand some of the gang for neglecting to report. Don't forget to report to SCM Carr on the 26th of each month. Even though your traffic report may be small, it helps on the total handled. Furthermore, how's the gang going to know of some good work you may have done if you don't let us know?

District No. 4 recently lost its DS when 1BLU moved to Boston. 1BSJ has been filling his place. 1AWW works DX whenever he gets on the air. He recently worked O-CNG, a military station near Paris. 1APL is busy logging DX. 1BWY, the station of the Springfield Radio Assn. has a code class with keen interest among some BCLs. 1AOF is a new ORS, whose UV-204-A can work any station heard. He is working on crystal control for the large set. 1CCP has no difficulty working DX. 1BON was on for two weeks but had some trouble with a good note from his mgr. 1AAC expects to be on again shortly. The Worcester County gang sure do turn out for the Annual Conventions. This year 22 hams from this district went to the N. E. Convention at Providence. 1DB has dropped to 40 meters. Did friends desert you on 80, OM? Hi! 1JE has been experimenting.

1GR will probably be the first crystal controlled station in Worcester. FB, OM. 1BIV is having little trouble getting results in his new location despite bothersome power leaks. 1AFD is looking for schedules. 1AKZ worked A7HL in Tasmania. 1ASU is using 20, 30 and 80 meters with good results. 1AUO and 1CRX are new hams in this district. Welcome to our ranks, OM. 1AJK did his bit for the RCC and delivered a love message from a ham to his sweetie.

Traffic: 1AAL 6, 1AFD 2, 1AKZ 17, 1ASU 11, 1BIP 5, 1DB 11, 1GR 2, 1BIV 6, 1VC 6, 1AAE 26, 1ARE 7, 1AMZ 113, 1AMS 10, 1AWW 11, 1PY 1, 1APL 12, 1AJK 3.

**MAINE**—Don't let the key get rusty, OM. Uncle Sam is giving us the helping hand. Let's not turn it down, but go after that Army Operator's certificate. The MMPC gang kept the state on the map in traffic work again.

1ADI is now a full fledged ORS. 1SO kept schedules with four US and Canadian hams. 1VF left for the Eastern Radio Institute, and hopes to hear from the gang thru 1YC. 1AVJ moved to Intervale. N. H. 1BNL solved the QSY problem. 1ATV took a message from (N) PB3 and gave it to 1CRE in no time. 1BG and 1BTQ spent a week end with 1KL, 1ATV, 1BEL and 1CCP. A lot of midnight oil was burned. 1BG is still handling oodles of traffic. 1BKK is going to sea again. Says he's going to take a ham receiver. (Give us the dope, OM—DM) 1KL is QRW baseball, exams, etc.

Traffic: 1AAV 66, 1APF 1, 1ADI 27, 1BNL 19, 1BUB 42, 1SO 44, 1AQL 7, 1BFZ 1, 1UU 7, 1ATV 117, 1KL 83, 1BG 239.

**VERMONT**—1BD, Prof. Gale, is rolling out FB now. 1BEB is on 41. 1BBJ is keeping good schedules and working Europe. 1AVZ is on little. 1YD, our star College station, had the hard luck to blow 2 pole transformers and a 50 wattier. 1BDX has a number of 10-KW bottles but they don't light. Hi! 1AC, 1AJJ, 1CQM, 1FN and 1APU are all on once in a while and hitting OK.

Traffic: 1BJP 12, 1AJG 22, 1AC 16, 1BD 3, 1BEB 12, 1BBJ 31, 1YD 35, 1BDX 8.

**EASTERN MASS.**—1BUO was QRW with final exams. 1GA 1BV and 1RF have hopes of getting a crystal. 1BVL steps out fine. 1AXA has his crystal going already. 1ALP gets reported "crystal control" but uses just pure DC, no crystal. 1UE wants an ORS and deserves it. 1AIR hits the air in

fine shape. IYC is bothered with QRM from motor. 1RF and 1ABA get out FB on low power. 1ADL sends in his first report. 1ACI reports the Attoboro gang dead. They need an undertaker, not a CM. Hi! 1ADM worked 5 Aussies and plenty of sixes. 1NT handled NKF and KEGK traffic. He is buying a car. 1JL is the North Shore traffic hound. 1AEO hasn't had time to push the key. 1LM sends in a good report. He has four schedules. 1NV says he doesn't seem to get out. 1BZQ changed his QRA. 1ACJ blew his last five watter but is rebuilding with an H tube. 1CJR has been busy at school. 1ZW has resigned and all reports should be sent direct to 1KY.

Traffic: 1GA 43, 1ABA 22, 1CH 4, 1YC 45, 1UE 54, 1SL 12, 1AIR 2, 1RF 4, 1ALP 4, 1BAT 1, 1AXA 4, 1BVU 18, 1ACI 26, 1ADM 6, 1ADL 22, 1AWR 5, 1BUO 1, 1BBM 3, 1ACJ 3, 1BMS 46, 1BZQ 40, 1CJR 17, 1KY 21, 1LM 100, 1NV 2, 1NT 30.

CONNECTICUT—1BHM worked South America and Europe seventeen times during the month. 1ADW's fifty went West but he will have another soon. 1BGC put up a small cage and picked up South America. 1MY doesn't star on messages originated or relayed this month. His specialty was 25 delivered and received principally from KEGK at Spitzbergen. Some relaying, OM! 1IV reports attending the New York Convention and having a very fine time visiting with some of the old timers. 1AYR and 1FD have been on the sick list. 1AVX, 1ZL, 1CBG, 1AOX and 1AOS all good relay men, are temporarily off. We miss their traffic and hope they will be back soon. 1VY is as enthusiastic as ever. The local Club is planning to have a radio exhibit from May 28 to June 5th. 1BM is in the midst of housemoving and apologizes for any errors or omissions. Please note change of address to 82 Elmwood Ave., Bridgeport, Conn.

Traffic: 1AYR 8, 1IV 2, 1CTI 7, 1MY 25, 1BGC 11, 1ADW 15, 1BHM 4, 1HJ 11, 1VY 3, 1ABN 6, 1CJX 8, 1BEZ 15, 1AJO 4, 1PE 14.

RHODE ISLAND—1BIE lengthened his antenna and works anybody he hears. 1BYB has been off due to business but is going full swing again, now. 1AAP is on with new transmitters. 1QV is building new ones too, for 40 and 80. 1CDS is building a new receiver that will be a wow. 1BQD worked Brazil twice using one UX210. FB, OM. 1AFO has his fone working FB. 1ALD had his power transformer blow during a recent thunder storm. 1AWE is doing well on 40. 1AID will have another YL on soon. Mildred's sister Lillian is about ready to come on the air. FB. 1BCC says "the air ain't wot it uster was." Hi. Meaning DX OM? 1AHE and 1DP in Pawtucket are at last on the air. 1AEL is on 80 meters while building a new 40-meter set. 1BPB is rebuilding his transmitter as a short wave relay to connect up with WEAN and WNAC. 1PB has moved to Catskill, N. Y. Good luck to you, OM, and let's hear from you soon with a second district call.

Traffic: 1BIE 9, 1PB 4, 1BQD 2, 1BCC 24, 1AID 18, 1BVV 2, 1AWE 6, 1ALD 1, 1AFO 47.

NEW HAMPSHIRE—1BTF is getting things in shape again. He has been in Florida all winter but promises to do good work this summer.

#### NORTHWESTERN DIVISION Everett Kick, Mgr.

THINGS seem to be going "haywire" on reporting lately. The new form of reporting has not been adopted, so please continue to report the old way until notice of our Division being run under the new plan. Several stations were eligible for the BFL but failed to send in their messages for recount. DX and QTC seems to be a lie with last month.

WASHINGTON—7FD, ADM—Due to an oversight by the ADM, last month's report for Dist. 1 was omitted. (Sorry, fellows—7FD). 7VR was QSO Waske at Point Barrow, taking a couple messages from him. Congratulations, OM! FB VY! 7DF and 7EK are having a contest to see which can QSO all continents first. Hi! The Tacoma boys are doing excellent work both in QTC and DX. 7AIM has a 50 row. 7TR is on occasionally. 7UR is a newcomer. 7TX has been operating 7SA and working piHR on schedule. 7AG announces the arrival of a new op. (The newcomer will probably do its own broadcasting for a while). Congratulations, 7AG! Mail your cigars. Hi. 7AB is program director at KFOA. 7DU is trying 80. 7RP is on with a fifty. 7NL is at Mason's QRA. 7FD will soon have a new transmitter. 7EN gets out fine. 7VK (7DZ & 7GY's new station) has a new shack with a 50.

Traffic: Last month's—7VL 64, 7FQ 21, 7MZ 21, 7QZ 8, 7TJ 3, 7MP 3. This month's—7GE 133, 7BB

72, 7FQ 58, 7AFO 54, 7EK 52, 7OB 22, 7MP 20, 7HN 18, 7NH 16, 7GB 16, 7CY 14, 7AF 12, 7DF 11, 7OY 6, 7EN 6, 7ABF 5, 7UQ 5, 7MZ 5, 7VR 5, 7TX 4, 7BO 3, 7IM 1, 7VW 1.

OREGON—7IT, ADM—The Portland gang did some fine work. 7LQ is on week-ends as he attends college at OAC. He leads the traffic gang and did excellent DX. 7WU worked a couple of South African stations the longest way around. 7OK had bad luck (tubes and QRN trouble). A few messages were handled, tho 7EO and 7AKH did fair work. 7EO is operating a cannery station in Alaska. 7WB's set doesn't perk so well lately. 7UJ and 7UN just installed a 50 watter at the Eugene High School, operating under the call, 7OM. 7UJ moved and hasn't had time to erect his 98 foot stick yet. 7LR is headed for a cannery station in Alaska. He will install several S/W sets in a hydroplane, cannery station and a boat. Various short waves will be tried and used. 7CE and 7PV are getting under way with fivers. 7AAJ rebuilt his rectifier and got a 1500 volt "bug". 7SY-PD has a schedule with 7OK. 7PI just finished a 40 meter set to go with his 80 meter layout. 7HB is trying to make a crystal work on 40.

Traffic: 7LQ 35, 7SY-PD 30, 7OK 20, 7UJ 19, 7AV 16, 7AAJ 16, 7EO 9, 7PI 3, 7AKH 1, 7IT 1.

IDAHO—7PJ ex 7OB ADM—7YA is the only active station and the only one to report this month. They are doing fine work with several ops keeping schedules with various stations and handling lots of U. S. Air Mail traffic. 7FT is pounding brass on a ship bound for Europe or Africa. There are several new hams in Boise but none on the air yet. Everyone is studying and practicing code for the R.I. is expected soon to give exams.

7YA 141.

MONTANA—7NT, ADM—7PU still leads the parade. He is picking up lots of traffic from HU worked every Saturday night. 7DD had power line QRM but kept his schedule with 6HJ. He uses 40 and 80 meters. 7NT recently came back from a splendid trip east where he took in about a dozen of the big noises of the US in the broadcast line. Getting glimpses of some 5 and 20 W tubes would make any ham's heart ache. Hi! 9ZT was one ham layout visited. 7EL promises to be back with us next month. 7AFP at Red Lodge is on 80. 7ACI is leaving to go up in the "11 of Idaho in the Forestry Service this summer. 7FL was FAW school.

Traffic: 7PU 67, 7DD 8, 7AFP 8, 7NT 4, 7FL 1.

#### PACIFIC DIVISION\* L. E. Smith, Manager Southern Section

ALTHO activity on the air was as great as ever, reports did not come thru with their usual snappiness. This is due partly to the changes being made in the C. D. and the fellow's misunderstanding how to report, and to the fact that some of the CMs and DSs have not been quite up to snuff, due to sickness and other causes. (Note: DSs and CMs don't put on the shoe unless it fits.—SCM) The SCM wants to warn all ORS now that as soon as the new reporting system goes into effect, an accurate check will be kept on all reports. Stations failing to report for two consecutive months will be dropped at once. ORS not receiving the monthly traffic bulletin and report card should notify the SCM at once. On May 3 the So. Section gang put over a ham frolic at KFVB, Hollywood. It was so successful that another is planned soon.

Dist. 1—6BQ, only home half the month, handled three times the traffic of any station in his district and ties for second in the Section. Very FB! Schedules with PI did it. 6BAS now has 4 complete transmitters and is installing crystal control. 6AJM is hitting 'em all with 7.5 watts.

Dist. 2—6BJK has been sick but lead the whole Section in traffic handled. Fine work, OM. 6AKW is making hay instead of pushing brass. Xmitter trouble is bothering 6AE. 6DAH is doing steady work. 6CTN says he longs for 80 meters. 6BBV works at Lowes States till the show's out then does his DX: a real ham. 6JI got pinched. At the present rate, in Los Angeles he may soon be in Jail. SOS. 6DDO is a prospective ORS and a good one. 6DAH is doing his usual consistent work. 6ML was QSO S. Africa, and is now getting his YL interested in radio. Fine work. 6BBQ is going to sea soon. 6BLS has schedules with Aust and PI. Notice his traffic total. FB. 6BTM works schedule with pi8CD and also has a real traffic total. 6CMQ now uses a 500 cycle outfit. WOW. 6BVO says 40 is sure FB for DX. 6OF worked BAM. A new 250 has been put in at 6ZBE. 6AJI is now a school boy.....radio school. A look at 6BJJ's traffic total is enuf. 6CAE works \* Hawaiian Section, p. 62.

S. Africa as easy as NZ. (consistently too). 6DAJ and 6AKX are new ORS starting out right. 6CGK worked WXP in Alaska. 6CQA and 6BUR alone upheld the honor of Whittier this month. 6KY is the new Official Relay Station at Warner Bros. Picture Studios—600 cycle 250 watts—on every night. 6BJX, watch your traffic lead! 6NW says there are too many "lids" on 80 meters and has dropped to 40 where he can handle traffic. Atta-boy. 6DAA had trouble with his power going back into the light lines. A feedback circuit, OM, Hi!

Dist. 3—6BVM, the only active station, is rebuilding. New ORS coming up are 6KB, 6AJJ, 6ALR and 6BAV. 6BAV and 6KB are entering the US—Amst. reliability tests. Go to it, OMs.

ARIZONA—Lamb is putting portable 6AYU on soon at the cattle ranch, tho. 6BJI is waiting for power. 6YB is experimenting with electrolytic rectifiers. 6ARX bought out 6ACL. A Tuscon radio store has installed 6AZV, with 6CBJ at the key. How's this gang? 6DCQ worked BAM, 6ASA and 6BJF are now going. Here's a good one: 6BWS built 5 receivers in 3 nights without results. He then found that the plate and grid of the detector tube were touching. WOW. He wants to correspond with low power ops. 6PZ keeps a schedule with his brother in SF—a family affair. 6CUW leads Arizona in DX, keeping a schedule with p1AU. 6AZM is a new station in Miami and making a good showing.

Traffic: 6AJM 67, 6SB 12, 6BAS 6, 6DAA 9, 6NW 23, 6CQA 10, 6AKW 4, 6BUR 26, 6BVO 10, 6OF 16, 6ZBE 18, 6AJI 18, 6DDO 52, 6ML 76, 6RN 47, 6BBQ 66, 6BLS 67, 6BTM 90, 6CMQ 33, 6JI 2, 6BYB 16, 6CAH 2, 6IH 6, 6BGC 13, 6BHI 7, 6AFG 4, 6RF 26, 6BJD 154, 6CTN 13, 6DAH 22, 6BJX 197, 6CAE 62, 6DAJ 17, 6AKX 14, 6CGK 5, 6KY 30, 6DCQ 62, 6CUW 62, 6AZV 8, 6CBJ 3, 6BQ 154.

#### NORTHERN SECTION P. W. Dann, Manager

6 CCY will use the portable call 6APJ this summer. 6BVY worked JIKK and has schedules with p1AU and p1DL. 6CIS was heard in China using two 301s. 6ADB plans to use 20 meters extensively this summer. 6NX is off the air until power leaks are remedied. 6CKV worked OISR in Rhodesia So. Africa. 6AMM is high traffic man for two consecutive months. 6OI is experimenting with 20 meters with CH9TC. 6BMW is second high man for traffic and continues to be one of the standbys. 6CSX is keeping schedules with 7GB. 6APS is another station to be working on 20 meters soon. 6ALW is installing a brass antenna system. 6AIH is a new OBS. 6CAK has been QSO east coast, Hawaii and KFUE. Traffic: 6CCY 4, 6BVY 14, 6CIS 8, 6ADB 6, 6CKV 24, 6AMM 78, 6OI 6, 6BMW 47, 6CSX 27, 6APS 29, 6AJZ 4, 6CAK 19, 6CEI 4, 6ALW 3.

#### ROANOKE DIVISION W. T. Gravelly, Manager

WEST VIRGINIA—The summer months show no abating of DX. 8AUL worked P-1AE and 8SGRA. 8CDV worked BZZAB and M9A 8BSU worked USE K9. 8AKZ, portable at 8BSU, has been cancelled for a two letter call. 8CYR is building a new transformer. 9BJG and portable 8AIA are having usual DX worked sixes. 8BNZ is a new station in Charleston. 8AWV worked Australia and England. 8AYP is again the star message handler. 8JZ and 8ALG are progressing with new station. The ADM appreciates the many visits of WVA hams at Wheeling. 8SP is putting in a new station. 8SV worked A. Z, Q. PR, HU and I on a 50 watt. 8IT is on a steamer on the Lakes, first class commercial op. 8ATC, 8DJN, 8DRR, 8BFW are very active. 8AMD deserves much credit for sending detailed reports for Huntington. The gang is preparing for the coming election for SCM and also for the A-USA tests. 8CEK is a new ORS at Wheeling. Traffic: 8AYP 250, 8CNR 76, 8DOI 72, 8SV 27, 8AMD 87, 8AUL 12, 8CDV 2, 8BJG 4, 8BSU 5.

NORTH CAROLINA—Dist. 1—4WQ is stepping out fine on 40 meters.

Dist. 2—4TS is fiddling instead of pounding brass. 4MI is the most consistent station but doesn't do much DX. 4NJ is doing a little work on 40.

Dist. 3—4BX at last has a real signal on 40. 4JR's traffic total dropped off due to QRN and cancelled schedules. 4QK is fixing to dismantle as his folks are leaving town.

6OLJ worked Africa O-AR with a UV201A tube. Traffic: 4MI 82, 4TS 18, 4NJ 11, 4BX 4, 4JR 88.

VIRGINIA—Dist. 1—8TI is building a new aerial soon. 8MK has been off the air on account of a blown transformer. 8CEL says things are about the same.

3UX says married life and vacation are causing QRW. 3AHL is rebuilding for the new H tube works. FB. 3SB has been reported to the R. I. for QRM to BCLs.

Dist. 2—Short wave interest has stirred this district. 3BMM is back stronger than ever. Ex3MT has donated a lot and shack the combined gang at Petersburg anticipate running a joint station, each taking a turn at the key per night. 3AJR has quit the game until can find a better location. 3AEV has been on fairly regular and blew another 5 watt. 3TJ has a 50 watt but it won't perk. 3AEV will move to 4BT for the summer.

Dist. 3—3IW is working on B battery supply for the big set. 3AAI is on in full blast with a new crystal control set on 38 meters 3KG gets lonesome and comes over to set it out with 3BGS. 3BGS is doing good DX on 40 meters with a five watt. 3BFE finds no time now for the game as he is kept busy shooting trouble around the store but promises to be back on the air soon.

Dist. 4—3CKL is not on much on account of QRM from school and visiting in Washington and Chapel Hill, NC with athletic outfit. 3BZ reports considerable rag chewing but no traffic. 3CKL and 3BZ visited at 3CA. 3BDZ will be at again soon.

Traffic: 3TI 14, 3MK 22, 3CEL 7, 3UX 4, 3AHL 12, 3AAI 12, 3BGS 5, 3CKL 16, 3CA 12.

#### ROCKY MOUNTAIN DIVISION N. R. Hood, Mgr.

UTAH—6CJB has been travelling and out of the city. 6CVA has been sick and also away on a visit to the west coast.

Salt Lake City—CM Mc Rae moved to Riverside for the summer months. Jones of 6CRR, is acting in his place. 6BTX on 83 meters worked NXG, reported to be in Alaska. 6BVB is awaiting an H tube. 6CRR is rebuilding. 6CRS kept regular schedules with the YL but has not done much ham work. 6RV takes traffic honors for the state this month. He keeps regular schedules with 6BDL and 9DVL. No report was received from Ogden, but we feel that it was probably addressed to McRae who moved to Calif. Traffic: 6BTX 33, 6CRR 2, 6CRS 1, 6CJB 1, 6CVA 7, 6RV 88.

COLORADO—Traffic is a little slow due to summer QRN. Attention is called to the work of 9EAE and 9DVL. FB, fellows! Keep it up. Let's try to originate more traffic, too. 9DVL did well and 9DKM deserves special mention for the percent of messages originated, too. Keep Colorado going strong this summer.

Denver—9RQX is rebuilding and should have a "be" station when thru. 9QL has been on some. 9EEA will be on in the next few days. 9CPK is a new station doing good work.

Dist. 1—9AOI rebuilt for 40, 80 and 180 meters. He is working with 9CAA and isn't able to be on much. 9DVL has been on very consistently.

Dist. 2—9UDE is away at a convention but reported before he left. 9EAE reports 9EHP opening up at Trinidad. 9DUI missed the monthly bulletin from Hartford but should be OK on the mailing list now. 9ADI is trying a self-rectified circuit.

Traffic: 9DVL 112, 9AOI 13, 9CAW 12, 9EAM 36, 9CDW 5, 9OO 18, 9WO 5, 9DKM 45, 9CAA 71, 9QL 5, 9CPK 22, 9DUI 53, 9ADI 14, 9UDE 7, 9EAE 122.

#### SOUTHEASTERN DIVISION A. D. Trum, Manager

SUMMER is with us again in Dixie. OM QRN is here for a few months and our shacks will be the mark of unpleasant and interrupted service. Reports are meagre in this division on account of school QRM which has taken most of our hams by storm. Finals make it difficult to get at the key.

ALABAMA—Good progress was made despite unfavorable conditions. 5AWF is erecting a new vertical antenna to get a better wallop out of the old set. 5AX, Papa Clancy, is strutting his stuff at the key bringing in the DX most consistently. 5VV got thru his exams and went on a vacation? Birmingham has a bunch of new hams. Watch their smoke! Keep your eye on W. A. Boon. Hurley of 5AC is taking a trip as messboy on the SS West Hika. He took his short wave set and will attempt to QSO 5DL. 5AAD, the fellow with the wallop, is making minor repairs to bring his set to standard. 5AJP the old reliable, is worked when the DM can find time. This station kicks a nasty wallop in the air. One thing can be said about the DM and that is he is a

great lover of rag chewing. 5AFS (W. H. Amerine) is stepping out well.

Traffic: 5AX 30, 5AWF 24, 5VV 2, 5DL 15, 5YB 164, 5ATP 25, 5ADA 33, 5AJP 29, 5AFS 6.

FLORIDA—Grogan (4QY) is fast bringing back Florida into its own. He wants all hams to report direct to him not later than the 20th of the month. 4QJ is on the air with a fiver. 4CE, 4CJ and 4AAO all of Homestead, are on the air with fivers and promise to place their town on top. 4OB and 4TK are on the ORS list this month and are doing their share of good operating. 4VS is a live wire and reports FB in Miami. 4KR has moved back to Memphis. 4KJ works quite a bit of traffic and handles schedules like a veteran. 4FM is on occasionally and gets results. 4FM is busy as a commercial op. 4VS worked HIK in Haiti.

Traffic: 4VS 33. Fellows who want to get in this report, do your stuff and report to Grogan on time.

GEORGIA—Morris must a got tied up with finals and just plain forgot to send in a report for the boys. Well, O.M. here's hoping to have a big fat one from you soon. Dupre's gang forgot to report too. 4MV did some fine work with his fiver on 40.

Traffic: 4MV 24.

## WEST GULF DIVISION

F. M. Corlett, Mgr.

THE DM usually has a word to say here—the

Section reports speak for themselves. Thanks to each ADM for keeping up the work of reporting and thanks to 5ARN of Las Cruces for giving us a line on New Mexico activities. ADM Ehret of Oklahoma paid the Division HQ a visit while down Dallas way, getting lined up with the Naval Reserve. ADM Forrest of Northern Texas, also dropped in for a few minutes—don't think he was lining up with the Naval Reserve—then again he might have been—may be it was a Yeomanette he had a date with.

NORTHERN TEXAS SECTION—This is probably the last report that your present ADM will turn in because the new Communications Department plan will be functioning soon. In signing off, the ADM wishes success to the new Communications Mgr. and hopes the gang will give him the support that the ADM has had during the past two years.

5NW is still pounding the usual DX and traffic brass. 5CC, 5ADD, 5AQL, and 5LS are all getting things in shape. 5AJJ states that the N. Y. Telegram is clamoring for lists of Calls Heard, and pictures of amateur stations. Here's a good chance to give our section a bunch of free publicity. Shoot a write-up, and photo of your station to Wm. Schudt, Radio Editor, N. Y. Telegram, New York City. 5AMZ is back on the air again and handling traffic. 5WW is doing some excellent DX work and DX traffic handling.

Traffic: 5HY 15, 5NW 18, 5AJJ 24, 5AMZ 7, 5AUA 9, 5SP 2, 5AKN 16, 5ACL 20.

SOUTHERN TEXAS SECTION—5APM is on with 50 watts. He has had some trouble getting the transmitter adjusted but has reached French Guiana. 5MS has three sets going on 20, 40 and 80 meters. He also reports a new ham, 5AHZ, using a 50 watt bottle. 5MS would like to make a schedule with a 50 watt fone. HW? 5EW will be on with 250 or 500 watts and the KWWG mg. Judging from the way their smaller sets have reached out, they ought to have some kick. 5ALA-5ALH will be on the air as soon as he gets some power in his town. This is a new ORS (pending) and we are glad to get this station in the valley. 5ZU now has a new 100 watt set working fine.

Traffic: 5ZU 3, 5HS 1.

OKLAHOMA—Judging by the number of appointments in the Army-Amateur Radio Net for Oklahoma, there should be about 25 stations reporting this month plus our usual number. A lot of the stations were unknown to us, while a great number appear to be old-timers who have eased up on the game. If a ham is reliable enough to fulfill his Army Net obligations, we believe that he will be 100% when it comes to his QST report.

5ATK has moved into 5AGN's old location and expects to hold up the traditions of the old shack. 5ADE was first one here to tie up with Chilean 3JJ, with the plates of his UX204. 5AAV had good luck filtering an advance sync. 5AAV worked KFUH then passed him along to 5APC who gassed with Roebuck

long enough to find out that he was anchored off the North coast of North coast of New Caledonia. 5APG says the 500 cycle encourages high speed and he don't give a whoop how much razzing he gets as long as he can pound brass with such guys as 5ZAI, 5ZA and 6TS. 5ANL still keeps schedules with 5APY but is going on his vacation about the 15th of June. 5ADO-5AML polished up his 7½ watter and was QSO Australia Tasmania and New Zealand. 5GJ has his new 1000 volt Esco and is putting about 360 watts on his 203A and was QSO R AAS, CH 9TC, HU FX1, R BAI, MJH and M 1K. 5JU still works on 80 and 180 meters.

Traffic: 5AAV 24, 5ATV 8, 5APG 20, 5ATK 20, 5ADO 20, 5ANL 35, 5ATO 30, 5JU 9.

NEW MEXICO—The tubes of 5AGU, 5AGP and 5ARN all passed out within a space of several days. Therefore, the activity in Las Cruces has been very close to nil. 5AGP accidentally cut his "fist" arm so that even if his tube were not deceased, he would not be able to operate. 5AGU has ordered a new tube and so he ought to be breaking up the ether again soon. 5AK is all "up in the air" lately since he has been taking flying lessons from an ex-army instructor. (Just another reason for the unusual quietness). 5ARN's H tube arrived OK but he is waiting on a transformer getting going again.

## CANADA

### MARITIME DIVISION

NOVA SCOTIA SECTION—W. C. Borrett, SCM—1DD has been ill but reports that 1CX, 1AC, 1DM, 1DJ, 1DD, 1AR, 1AE and 1ED are all active. The weekly broadcast message is being sent out by broadcast station CHNS at Halifax Wednesday evenings on 322.4 meters as well as by the regular broadcast stations.

NEWFOUNDLAND SECTION—Loyal Reid, SCM (pro tem)—Since 5AR returned from the St. John Convention, conditions have been poor. 5AF will soon be on the air to stay. 5AR and 1ED keep a daily schedule at 1630 GMT. Reception on 52.51 meters on Wednesday nights has been poor. 5WM is plugging away with the miles per watt idea. Ham activities will be taking a boost here this summer. (Report sent by radio —FB—CGM—DM).

P. E. ISLAND SECTION—T. A. Hyndman, SCM (pro tem)—Several traffic schedules have been formulated which will result in traffic being originated soon.

NEW BRUNSWICK SECTION—T. B. Lacey, SCM (pro tem)—1AF just returned home from St. John law school and is on the air. 1AD, 1AQ and 1AU are heard occasionally. 1AB will be on soon. 1BO is busy experimenting. New ideas for the gang shortly. Doctor M. Cruickshank's new St. John station is ready to start. He uses call letters 1MD until his are allotted. Free "PERS" QLC? There may be two new stations in northern N.B. and another in St. John soon. 1EI is on the air again after his set was partly destroyed by lightning which came in on a power line, wrecking transmitter and receiver. The N. B. Section is hitting on all fours and forging ahead.

Traffic: 1AK 18, 1AI 16, 1AM 14, 1AN 5.

## QUEBEC DIVISION

Alex. Reid, Manager

2 AX, 2BG, 2AL and 2BE are regulars on 40 meters. 2HT, 2CM and 2EV are using fone on 175 meters.

Interest in this great game of ours is very low, and it is a safe bet that there are not more than five active stations in our Division. Can't someone please come forward with an idea for injecting pep into the boys? The DM can't understand conditions. When we call a meeting or hold a hamfest, the attendance is never below 25. Everyone appears to be really interested, but listen in, gang, and see who you hear on the air.

The DM attended the Hudson Division Convention in New York. The lectures were wonderful, particularly those by Reinartz, and Dr. Hoyt Taylor. It was also very interesting to meet so many real hams. Dr. Dunn sure deserves a great amount of credit for the way the Convention was pulled off. The CGM was also present. By the time this goes to press, it will be mid-summer, and naturally DX and traffic will be at a minimum, but it is the best time for new hams to be breaking into the game and for the old timers to rebuild for the coming fall.

Traffic: 2AX 5, 2CB 9, 2BE 8.

ONTARIO DIVISION  
W. Y. Sloan, Manager

**3** FC STEPS OUT AGAIN. QSO WITH A7DX AT TASMANIA DURING ANZAC TESTS.

The combination of "Spring examinations, spring fever and spring static" has made itself felt throughout the whole division this month.

Over one and one half newspaper pages of amateur and ARRL news were published in Toronto and Niagara Falls papers during April-May. The personnel of the Publicity Department for Ontario now consists of James Montagnes, Toronto, D.N.M. & C.N.M.; Jack Hewson, Ottawa, A.D.N.M., and F. C. Rutherford, St. Catharines, Correspondent. Other positions are vacant. Applications wanted.

**EASTERN DIVISION**—F. A. C. Harrison, ADM—Good work is still being done on our 52.5 meter band. 3AFP arranged a schedule with 2BN on this wave but has not received a report yet. 3BN is now using a UX210 with good results. 3JL is trying out a new N.E. diver to see if he can keep the filament in one piece for more than a week. 9CC has moved to a new location and in spite of getting his flvver mired a few times en route, had the Magnavox percolating within a few hours. 3AFP is sending out more standard-frequency signals on the 52.5 meter band that will be checked at the Test Room on the Canadian Standard Wavemeter.

**CENTRAL DIVISION**—A. R. Williams, ADM—The out of town reports are conspicuous by their absence. 3CC with his newly assigned call at Hanover, and 3AI at Hamilton are heard regularly on 52.5 meters. 3AI kicks up a great dust here in Toronto with his 201A transmitter. 3CK leads the traffic list with forty messages handled. FB, OM. 3EL is building a new shack and getting things ready for summer work when exam QRM will be over. 3AJ is working all districts and looking for foreigners with his new fifty. 3AZ is pounding brass in the early mornings to overcome the QRM of the BCLs and Daylight Saving Time. 3BR is working on a sync rectifier and reports it FB. Off the air for the time being, due to QRM from school work. 3MV is still banging away. This station was awarded the division Traffic Shield Trophy for the English QSO. 3AV is trying out short wave work on an indoor Hertz. (It should have a real kick with all that DC behind it OM. FB—DM). 3FC is away in a cloud of dust again. This station, the only one in Toronto to have worked on Aussie, hooked with A7DX, and handed him a long test message, during the Australian Two-way Tests! Good biz, Ernie, that gives the rest of the gang something real to shoot at. 9BJ has left the city for the summer but "AJ" will be on the air with a low power set on 52.5 meters at summer quarters on Toronto Island. 9AL has a new low-power master oscillator set going and he may give the big lantern a run for the money with it. No report this month from either the Northern or Southern Divisions. What's the matter, fellows?

Traffic: 3JL 20, 3KT 8, 9CC 8, 3JW 6, 3AFP 6, 3CK 40, 3FC 26, 3EL 11, 9AL 18, 9BJ 9, 3AJ 6, 3AZ 3, 3MV 3.

PRAIRIE DIVISION  
F. E. Rutland, Mgr.

**MANITOBA SECTION**—In spite of the efforts of the DM and his assistants to keep the gang on the air, it can be seen from the slump in traffic that most of the gang have been smitten with "spring fever". Don't forget gang that the 40 and 52 bands are at their best in summer months. Forget that old line, "laying off" for the summer. Overhauling and rebuilding in the summer is quite in order but THAT SHOULDN'T TAKE ALL SUMMER. Neither do summer holidays. It is pleasing to note that the 52.5 meter wave is coming more into nightly use. It was given us for this purpose and should be used for all Canadian traffic EVERY NIGHT. 4DY is building a new Schnell receiver. He is on regularly on 52.5 and 40 meters. 4DW continues his good DX on 20 meters. Traffic mostly on 40 and 52 meters. 4EA is making changes in his set. (We presume he means a rectifier). ADM. 4BT uses an indoor aerial with a 210 tube and gets out good. 4AW is on as often as his limited time permits. 4GF reports he cannot get good results on 40 with his present antenna and is busy with a new one. 4AE has a new tube and hopes to work the Zedders. 4DB is using fone on 180 but is coming down

to 52 and 40 on the key. 4DT has 4 201A's on 40 and 52 and is QSO all parts of the USA and Canada.

Traffic: 4DY 14, 4AW 3, 4EA 11, 4DF 5, 4BT 15, 4DW 12.

**SASKATCHEWAN SECTION**—Activity was not so good in April. (A lot of reports are missing. We can't tell what you are doing if you don't let us have the dope.—ADM). 4AQ is still pounding away but reports too much QRM. He is going down to 40 and 52. 4HS is improving his speed and works 800 miles over the Rockies with 60 volts on a 201A. He will probably be on with a Telefunken 8 watter or a 250 shortly. 4FV has his junk pile together again and reports working Honolulu several times. 4AJ will be in Toronto at 9BJ all this summer but Regina will be represented by two new low powered stations soon. 4IX is experimenting with filters for Heising modulation. 4IQ is heard from and is doing well on 52 meters. 4GH is putting out the broadcast. 4AC has a dynamotor and is getting out good all the time. 4HH is laying off pending the arrival of a barrel of ammonium phosphate for his rectifier. 4AO is stationary. Inspector ship work absorbing his energy?

VAN-ALTA DIVISION  
A. H. Asmussen, Manager

**WHAT'S** the matter, gang? This month's report is a little slim. 5GT, the DS for Northern BC, has not been heard from—what about those new stations you promised? 5GO sent in the best report. He has a new ORS lined up. It is with great regret we have to record the death of 5AN. He was well liked by everybody. 5CR, after two weeks layoff, reports bumping R7 sigs into HU. He hopes to QSO the Aussies soon. 5GF has reports from NZ and Tasmania. 5GF's mast came down during a storm. He blames a bird for hitting one of the guy insulators—better try something beside cleat insulators. OM—DS—HI. 5GO still complaining of power leak QRM but has a fine message total. Four of the Vancouver bunch are going camping for a couple of months but will be on the air at camp (do you expect to have a good supply of bottles on ice?) 4AH is trying for commercial ticket. Take your short wave set with you, OM. 4HF is on occasionally. 4HL is experimenting with new receivers. Let us have some fresh dope, OM. 4CL is QRW University. Why not train second on OM? 4AF with home equipment and low power, turns in the best message for Alberta. 4DQ reports rebuilding for a fifty. Guess one of his converts will fall heir to the low power set. 4GT is QRW business and has sickness in the family but is looking forward to summer DX. 4IO claims more stations coming back to 80 meters and hopes for a better message total in consequence. 4AL lost his mast in a windstorm. 4CC is another ORS on 40 meters open for Calgary traffic. 4AG is the new Secretary for the EREA and a very active publicity manager for the ARRL. He is stepping out FB. His correct QRA is 325 24th Ave., West Calgary, correct your call lists. 4AU expects to use his Commercial op's ticket in the Calgary Oil fields. Medicine Hat boasts two new hams. One of them, 4JJ, is testing daily at 1.00 pm and 7.00 pm MST on 40 meters. 5CT complains of bad QRM but has a rival in one of his converts. FB, OM.

Traffic: 5CR 5, 5GF 3, 5GO 26, 4AF 22, 4GT 2, 4IO 2.

HAWAIIAN SECTION  
K. A. Cantin, Manager

The past month saw several new stations on the air in this Section. Traffic delivery on the mainland has improved since local stations send their messages via mainland stations that are on the air for traffic and who deliver or relay what they receive.

6CLJ worked Africa O-A3B with a UV201A tube. 6CST reporting hearing the first European station FI-8QQ. 6AJE is back on the air and making up for lost time. 6CFN has schedules with 7ON. 6CFQ has been QSO Australian and US 9th district stations. 6ASR is on again with a 250 watter. 6GT is trying to build up a working schedule with US 6th district. New Zealand and Australian stations. 6NL is out for traffic. 6AJL returned from a trip to the mainland. 6DBI has requested ORS application blanks. 6CMH is experimenting with storage battery plate supply for his transmitter. FX1 and 6DCF's 40 and 20 meter CW transmitter is doing excellent work.

Traffic: 6AXW 166, 6BUC 132, 6BDL 91, 6AFF 83, 6OA 66, 6CLJ 54, 6CFQ 39, 6GT 21, 6CST 20, 6AJE 15, 6CFN 10, 6ASR 7, 6NL 3.





# I.A.R.U. NEWS

## British Section

"British hams appear to have done very little DX work during the past month, and reports are few and far between. We seem to have been passing through a very bad period of atmospheric conditions. Work with North and South America and Canada has been fair at times, but two-way work with the Antipodes has been very poor. Several low power stations are working in Jersey Channel Islands and have done good DX work with about 10 watts. These include g2ZC, g5GW, g6OX and g6PU, all of whom have been QSO the U. S. g2OD and g2KF have put some good phones across to a2CM. So far we have no reports of two-way phone with Australian stations but we hope to accomplish this soon. g5SZ has done some low power tests with oA4Z. g2LZ has a regular schedule with u1CAL every night; every night for the purpose of obtaining data on the influence of weather conditions on DX work. All British hams who are not I. A. R. U. members should get in touch with g2LZ concerning membership."—*E. J. Simmonds, President.* From the Secretary of the QRA and QSL Section of the Radio Society of Great Britain (T & R Section) we understand that an excellent organization is in existence for the prompt delivery of QSL cards for readdressing to transmitters in the British Isles, and on the continent of Europe. All cards can be sent in a single package, thus saving postage on individual cards. All communications should be addressed to Secretary of QRA and QSL Section, 82 York Road, Bury, St. Edmunds, Suffolk, England.

## Czechoslovakia

From esOK1 we learn that there are only two licensed amateur stations in operation in Czechoslovakia. Quite a few amateurs are transmitting without licenses. Among these are csAA2, cs1RS, csOK1 and esOK2. OK1 has worked all Europe, all of the U. S. districts except the 5th, 6th and 7th, c1AR, Porto Rico, Brazil, Mesopotamia and New Zealand. The transmitter at OK1 uses a modified Colpitts circuit with an input from 4 to 170 watts. For work with the U. S. seldom over 70 watts is required.

## Denmark

"The Danish amateurs are now operating within the law, at last. About twenty five licenses have been granted in the past six weeks. Through the courtesy of the Telegraph Department the call signs allotted consist of the figure "7" followed by two letters, as in the precicensed days. The letters are usually taken from the licensee's name, or any special letters he may desire can be used. The regulations are very reasonable. Inputs up to 100 watts are allowed. Transmission can be done at any-time except 7:30 to 10:30 P. M. The wave bands are: All waves under 15 meters, 43 to 47 meters, 70 to 75 meters and 95 to 115 meters. The license fee is 20 Kroner (about \$5.00) a year. We are trying to get a waveband somewhere around 30 meters. With the exception of 7ZM we are all using inputs under 20 watts. We hope to be QSO the U. S. long and often now. Any QSL cards addressed to the writer will be forwarded to their Danish destination."—*James Steffensen d7JS, Ehlersvej 8, Hellerup, Denmark.*

## Dominican Republic

A new country has entered the ranks of ham-radio. Koerner of u2CEP was instrumental in getting J. Chapman, chief operator at the commercial station HIK, interested in short wave work. A UX-210 transmitter furnished the necessary means, and HIK is now on short waves working many amateurs. The wave length is around 45 meters, and the QRA of HIK is care Cuban Dominican Sugar Company, Barahona, Dominican Republic. F. B.

## Italy

Via radio from i1NO through u3LW we have received the following: "i1GW was the first Italian station to be QSO Chile when he and ch2LD connected. i1GW has also worked y2AI and has been heard in South Africa and Chile. i1RG has deserted the key and is now radiophoning all over Europe. i1NO has been heard in the sixth U. S. district by u6NH and in Canada by c4AA. In one month he held 137 DX contacts with 104 different stations. He is now QSO z2BX and oA6N nearly every day. i1ER is QSO z2BX and other DX often.

11RR is testing on 5 meters. The 1925 contest for the best amateur station ended March 31st.

11NO, 11AS, 11AU, 11AY, 11GW, 11RM, 11BD and 11MA are in the lead. The result of the contest will be announced shortly. 11MT is now 11NA. All amateurs are requested to look out for 11TA in Tripoli, North Africa." 11NO.

#### Mexico

A radiogram from Harold Mapes, mBX, on May 21st was received as follows: nr 64 via 2ABT, SBJV ck 50 from Mexican BX, Guanajuatoe, Mexico to QST Hartford, Conn. *This is the last nite old BX will be on the air stop new law allows only Mexicans to transmit in Mexico so BX will be heard no longer but will be listening in on the bunch often stop vy 73's to the gang and the ARRL success always (sig) Harold Mapes.* Mapes is a very old timer, being a pre-war "Q", a commercial operator on a freighter during the war and one of the pioneer amateurs of Mexico. We are indeed sorry to learn that he, and the other "foreigners" in Mexico will not be with us on the air any longer. Best of luck to you all, OM.

#### South Africa

From our friend R. Oxenham, oA4L at Cape Town, we have just received the following very excellent account of South African regulations and activities. "New regulations, it is hoped, are shortly to come into force, but until same are sanctioned by Parliament things remain as they have been in the past. It is unlawful to install or erect an aerial anywhere in the Union of South Africa without first obtaining a Government license. These licenses have been divided into four sections; (1) B. C. L. license, (2) Experimental Listeners License, (3) Experimental Transmitting License and (4) Full experimental license, for both receiving and transmitting. The transmitting regulations stipulate that not more than 50 watts are to be used. All waves from 200 meters down are allowed for experimental transmission work. The operator must be able to copy not less than 12 words per minute. No messages of a telegraphic nature are permissible. All messages must be of a test nature or must relate to test work. In January of this year a conference was called by the Post Master General to consider all matters pertaining to radio in the Union. The various radio societies were requested to send delegates, and all the societies requested that the South African Radio Relay League should represent them, and the general interests of the amateur. The League appointed Streeter of oA4Z, Adenorff, Editor of S. A. Wireless Weekly and the writer, oA4L. Representatives from the commercial and broadcast interests were also present at the con-

ference. One point of interest in connection with the meetings was that no objections to amateur operation were voiced by either the commercial or broadcast folks, and not a single case of amateur interference with either of these services was brought up. The amateurs asked for more power and requested that raw A. C. be disallowed and that all amateurs be required to use loosely coupled circuits. It was particularly pleasing to note that our newly formed South African Radio Relay League was recognized by the authorities as the representative body of amateurs. All S. A. amateurs use the intermediate O followed by calls A3A to A3Z, A4A to A4Z etc. South West Africa has its first licensed station A13A. In Rhodesia the amateurs have assigned themselves calls as 1SR, 2SR, etc.

Amateur radio in this country has made enormous strides in these last few months. Communication has been established pretty well throughout the world. New Zealand seems to be our main stumbling block. A few of the stations deserve mention for the splendid work they have done. A4Z, who by the way is using a Hertz antenna now, has put many hours of hard work into improving his station. His note is a real credit to him. His station, I am sure, must rank among the worlds best. A6N is another fine worker and uses much less power than some of the other preeminently successful amateurs. He is an engineer at the new Marconi Beam station, but still keeps amongst his old associates in the amateur game. His DX has been to all of the world. A4V and A3B of Johannesburg have both established communication with Honolulu, our Antipodes, and they are now well heard in the States. At present our main DX workers are more or less to be found amongst the following who have all communicated over seas; A3E, A3Z, A4L, A7B, 1SR, A5Z, A4X, A6A, A3K, A3M, A4W and a few others. Special mention should be

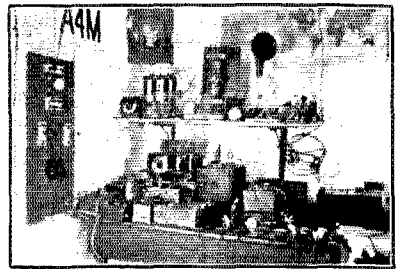

SOUTH AMERICAN A4M  
The station of Mr. S. C. Pleass

made of the fact that A5Z, with his pure D C. note, has been using only 20 watts but has been QSO Hong Kong, Dutch East Indies and many other DX places."

Although not a DX transmitter, we are certain that there is no better DX receiving operator than S. C. Pleass of the well-known oA4M. During the NRRL cruise Dr. Taylor of NKF reports that the log of NRRL reception from oA4M was the most complete received from any amateur and one of the best he had ever seen. Pleass is unfortunately situated in a locality where electricity in almost any form is unavailable. His activities, consequently, have been more at the receiving end of the game, although he now has a small transmitter which has a 900 mile DX to its credit. The photograph shows part of the "gear" used at oA4M. The battery panel and antenna-ground switches are on the board at the extreme left. The circuit used in the receiver is the familiar single-circuit regenerative tube plus varying numbers of audio frequency stages. The tuning condenser appears just to the right of the battery panel. This condenser is fitted with a string vernier, the pulleys in this case being grooves cut in the dials themselves. To the right of the tuning condenser is the detector unit. Directly behind the detector is the plug-in tuning unit. This holder is fitted with removable coils to cover all waves from below 15 to above 20,000. The coupling between the tuning coil and the tickler is variable through the long extension handle provided on the tuner. Directly behind the tuner is a Western Electric two stage audio frequency amplifier. To the extreme right is the wavemeter fitted with removable coils. On the shelf above the receiver the 30-watt transmitter is located. Pleass has logged 874 different amateur calls. He gets most of his pleasure out of keeping a very excellent log, sending QSL cards and acting as an official observer for all manner and sort of tests. Fine work, OM, and may there be more power to you!

#### National President Elected in Italy

The solicitation of nominations for National President for the newly-formed section of the International Amateur Radio Union in Italy resulted in but one name being placed in nomination, Professor Giuseppe Vanni, Viale Mazzini 8, Rome, whose nominating petition was signed by the majority of the Italian members. In the absence of competition, Professor Vanni has been declared elected, by the International President, for a two year term beginning May 15, 1926.

Letters of advice have been sent the I. A. R. U. membership in Italy, and their support of the new president is earnestly solicited.

In The I. A. R. U. News of June we inadvertently omitted the Porto Rican and Phillipine Island amateur intermediates. They are PR and PI respectively.

## WWV Schedules

THE standard frequency signals from WWV, Washington, D. C., for the months of July, August, September, October, are as follows:

### Schedule of Frequencies in Kilocycles

(Approximate wave lengths in meters in parentheses)

Eastern Std. Time	July 20	Aug. 20	Sept. 20	Oct. 20
10:00 to	125	300	3000	550
10:08 p.m.	(2400)	(1000)	(100)	(545)
10:12 to	133	315	3300	630
10:20 p.m.	(2254)	(952)	(91)	(476)
10:24 to	143	345	3600	730
10:32 p.m.	(2097)	(869)	(83)	(411)
10:36 to	155	375	4000	850
10:44 p.m.	(1934)	(800)	(75)	(383)
10:48 to	168.5	425	4400	980
10:56 p.m.	(1800)	(705)	(68)	(306)
11:00 to	205	500	4900	1130
11:08 p.m.	(1463)	(600)	(61)	(265)
11:12 to	260	600	5400	1300
11:20 p.m.	(1153)	(500)	(55)	(231)
11:24 to	315	666	6000	1500
11:32 p.m.	(952)	(450)	(50)	(200)

## Strays

We get lots of requests to supply QRA's of stations here at headquarters. Ninety percent of them read like this: "On June 4 I worked XYZ for fifteen minutes. Please send me his QRA so I can QSL a card."

Fellows, when you work a new one, GET HIS QRA WHEN YOU WORK HIM. The chances are about 7 to 1 against ARRL having the QRA's of new calls like that; it is often months before we get the location, and then it is usually only through somebody who has worked him and sent us the address. You will be helping yourself by taking five minutes to get his address while you have him.

When you do get it, SEND IT TO HEAD-QUARTERS SO THE REST OF THE GANG CAN BENEFIT.

Have a heart, fellows, and do your bit.

—A. L. B.

The OWLS Committee takes pleasure in announcing that its OWLS—SF (Standard Frequency) service will be resumed about the first of August when schedules will start from Iowa State College, probably under the call 9XBB. Watch August QST for further details. 1XM will probably resume about October 1st, and it is hoped that a Pacific Coast station will start about the same date.—K. V. R. L.

When advising of change of address for your QST subscription, please tell us if it should be changed on other headquarters records. When you simply say "change my address" we take it as referring only to QST. Lots of you fellows belong to the I.A.R.U., Experimenters' Section and the O.R.S. and O.B.S. sections of the Communications Department. If you will tell us what records should be changed it will help immensely.

# Correspondence

The Publishers of QST assume no responsibility for statements made herein by correspondence



## Amateur Co-operation

El Paso,  
Texas.

Editor, QST:

It may be true that there are some hams who think of themselves only and are unwilling to let others profit by their knowledge, but they are not all that way. To prove it I want to call attention to one of the best examples of co-operation between amateurs and a public service company that it has been my pleasure to witness.

The El Paso Electric Company recently constructed some eighty miles of transmission line in the Rio Grande Valley. Part of this line was put in operation temporarily at 13 K.V., later to be cut at 66 K.V. As it was necessary to kill the 13-K.V. line in order to cut in seven transpositions the work had to be rushed with all possible speed to avoid inconvenience to a large number of customers. It was part of the writers duty to lay out the work of forty men in such a manner that it would not tie in with other gangs on the lower section of the system.

One of the first and most important problems was to provide quick and accurate communication between all gang foremen and the El Paso end of the line. It was possible to use the telephone company's long distance service, but the necessity of switching the calls through three exchanges made it too slow for handling switching orders or other emergency business.

The writer got in touch with three amateurs, Louis Gemoets, 5AJW, H. L. Brown, 5AOT, and Scott Bledsoe at KFXH, and asked their assistance. These men spent several days of their valuable time experimenting with various types of antennae and different locations for the portable set. The final layout consisted of a low horizontal antenna and counterpoise strung in opposite directions for the transmitter, and a short piece of number 18 fixture wire about six feet off the ground, with a similar counterpoise, for the receiver. Notwithstanding the fact that forty meters is none too good for such short distance work, the two stations were in continual communication for nine hours and handled some forty important messages during that time.

The officials of the company were well pleased with the excellent results obtained and expressed their appreciation of the valuable service rendered by these amateurs.

—Lon G. Wainman, Electrical Inspector,  
El Paso Electric Co.

## Power Tube Filament Control

8425 Hickory Street,  
New Orleans, Louisiana.

Editor, QST:

I have been reading the correspondence column of QST for the past three years and find the radio kinks and suggestions from other hams both interesting and valuable.

Often the ham thinks a while before paying for a primary rheostat, although this is a valuable asset to any transformer set. The

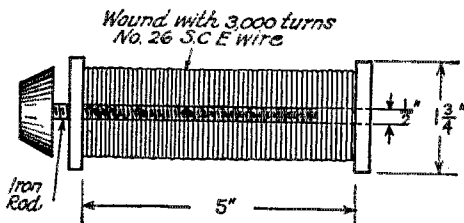

writer had a filament transformer giving a secondary voltage of thirteen, and as it was intended for use with a 7½ watt tube a rheostat was required. Since the secondary was provided with a center-tap I did not want to unbalance it by placing a rheostat in the secondary. A primary control was needed.

A solenoid was hooked in series with the 110-volt line and the transformer, and inside the solenoid an iron rod was arranged to be slid back and forth. The solenoid had the dimensions shown in the diagram and was wound with three thousand turns of No. 24 S. C. C. magnet wire. The iron rod was a 3/8-inch bolt three inches long.

Using this device a smooth variation in secondary voltage from 7 to 13 volts was obtained. Simple, cheap and OK.

—Ben. J. Rauch.

## "Q S P Fathers"

1762 No. Vermont Avenue,  
Hollywood, California.

Editor, QST:

Every "dad" with a boy between 15 and 20 years of age ought to be compelled to subscribe to QST for said son. A boy really interested in Amateur Radio does not require much "night watchin'g," even though said boy keeps late hours. Maybe you have never looked at the matter in this light but A. R. R. L. is a great character builder.

Being in the radio business, I naturally wanted the son part of the firm (age 16) to be interested in radio. It did not seem as though he would fall for Dad's wishes, but he did, and it was a subscription to *QST* that turned the trick. Now he is on the air (6BXR) with a transmitter, built from *QST* specifications and is being reported R-7 from Eastern points using an old 5-watt tube. His "Schnell" receiver brings in the Aussies with a bang and the Old Man himself is now trying to forget certain letters of the Morse code and learn certain ones in Continental to replace them so that we may together get the full kick out of it.

This store and this writer are boosting *QST-A. R. R. L.* and amateur radio in general, and our interest is not entirely mercenary either. More power to the American Radio Relay League, and to your gang at Hartford who must be hard workers, judging from the work they do.

—H. D. Hatfield.

## A Good Suggestion

1317 N. Harrison Street,  
Fort Wayne, Indiana.

Editor, *QST*:

I have found it good practice when tuning up the transmitter, especially in the case of a new one, to listen in on the receiver (with aerial and ground disconnected) at three times the transmitter wave. It is possible to tell exactly what your note sounds like to the other fellow, and to tell if it is wobbly. If the tube is allowed to cool off for a few seconds and then the key is pressed again, you can tell whether the wave climbs or the note changes or surges.

Also, especially when operating the oscillator at some harmonic of the antenna system, it is possible to tell when the coupling is just a hair too close. If it is, harmonics can be heard in the receiver at every graduation on the dial. When the coupling is right only the odd harmonics can be heard with any volume, the even harmonics being very feeble.

—L. B. Wilcox, 9DPJ

## WX Broadcasts

Concord, Mass.

Editor, *QST*:

I am broadcasting local weather conditions given me by Mr. F. A. Tower of Concord, the local weather observer. The broadcast is at 6:30 P.M. E. S. T. while Daylight Saving Time is in force in Massachusetts, and after that it will be at 7:30 P. M., in the 40-meter band. The wavelength is usually 42.6 to 42.7 meters, sometimes changing a bit to avoid QR.M.

I think it would be at least interesting, if not of more value, to know weather conditions in various sections of the country. Knowledge of these conditions might explain certain phenomena. One station alone, of course, can do little but if a number of stations were to transmit local conditions it would be of some value.

As far as I know I am the only one to broadcast this kind of information, but if there are any others who are doing it or who are interested in it, I would be glad to hear from them. By the time this letter is in print I may be doing this work on eighty meters also.

—Henry D. Hall, 1NV

## Cooperation Asked

Buenos Aires,  
Argentina.

Dear Mr. Maxim:

We are always grateful to consider all important affairs as a motive to communicate with you as the intermediary of the powerful organization of which you are president. We come to you with a proposition for a greater and more efficient communication between your amateurs and those of South America. We want to suggest a more permanent arrangement for our experimenters in general. It is also interesting to our colleagues in Uruguay, Chile, Brazil, Paraguay, Bolivia, Peru, etc., with whom we have cultivated the greatest co-operation in our activities for the best progress and development of radio.

We suggest the following. 1st. That your amateurs shorten their CQ to one minute followed by their call. 2nd. That your amateurs send their name and location about every fifteen minutes, (when *working* So. American stations, not when just calling.—Editor) and third that they do not abbreviate the words so much so that our amateurs, when losing letters, cannot reconstruct the word. It is impossible to do this now with such short abbreviations.

If your amateurs who transmit will observe this system we will receive all dispatches and we will be able to send them cards, as we desire to do.

—Jose M. Poledo, President, Manuel Torrado, pro-Secretary Radio Club of Argentina.

## Paralleling Tubes

706 Broad Street,  
Selma, Alabama.

Dear Eddy:

Down here at the Alabama Polytechnic Institute station 5YB, we shot our one and

only 50-watter. As soon after the services as was appropriate, we went and asked the Institute's Radio Department for another one, but they said ND. They told us, however, we could have one of the 250 watters out of old station WMAV, the local broadcasting station. Of course we raised an awful kick (who wouldn't we asked for a 50-watter and they tried to force a 250-watter on us) but finally we were persuaded to take it. Well Eddy, that ole bottle had been so used to doing its stuff on the high waves that we couldn't get it to perk on 7500 K. C. until we put 3,000 volts on the plate. The poor defenseless Kenotrons did their best but the note was reported as being decidedly mushy. After carefully putting the rectifier tubes back in their boxes we installed a sync. The first time the key was pressed it looked like Christmas had come again, there were so many fireworks. No amount of persuasion could make those volts stay in the sync instead of running all around the operating table, so, in desperation, raw A. C. was put directly on the plate of the tube. Now Eddy you know what that sounds like.

We remembered something about self-rectification and so we got the Radio Department to let us have another bottle. After hiding all traces of past struggles the new tube was hopefully hooked alongside the original one. We pressed the key, and BiGosh the two tubes worked like twin brothers who were used to putting out good signals on 40 meters all their life. The gang told us the note was very smooth RAC and that we were nearly punching the diaphragms out of their cans. Now Eddy, I would like very much to hear from any of the gang who have tried this method of solving their high voltage rectification problems on short waves.

—K. Bewig, 5DI

**SEE THAT SCREW**

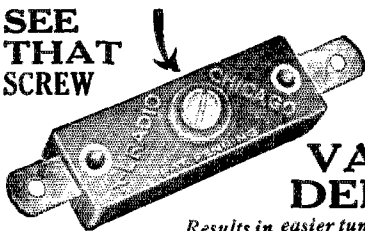

A screw driver adjusts an X-L in crowded places.

## X-L VARIO DENSER

Results in easier tuning, more distance, volume and clarity—greater stability Indorsed by leading radio authorities.

Model "N" this now with such short abbreviations.

A slight turn obtains correct tube oscillation on all tuned radio frequency circuits. Neutrodyne, Roberts two tube, Browning-Drake, McMurdo Silver's Knockout, etc., capacity range 1.8 to 20 micro-micro farads. Price **\$1.00**

Model "G" with grid clips obtains the proper grid capacity on Tokay circuits, filter and intermediate frequency tuning in heterodyne and positive grid bias in all sets. Capacity range .00016 to .00055 and .0003 to .001 micro farads. Price **\$1.50**

X-L Push Post Push it down with your thumb, insert wire, remove pressure and wire is firmly held. Releases instantly. Also furnished mounted on strips. Price 15c.



**X-L RADIO LABORATORIES**  
2428 Lincoln Avenue N. Chicago, Ill.

68

### Correction

On page 23 of May QST, J. E. Roberts is referred to as the author of the "well-known reflex circuit." Mr. Hatry, writer of the article, informed us that this was incorrect and this statement should not have appeared. The error was ours, not Mr. Hatry's. Walter Van B. Roberts is the author of the circuit in question.

# EAGLE

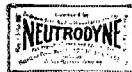

## All That's Best in Radio

Eagle Owners have the satisfaction of knowing they have the best Radio Receiver made, regardless of cost.

Ask Your Dealer



## EAGLE RADIO COMPANY

16 Boyden Place Newark, N. J.

## ACME

### FLEXIBLE CELATSITE

Flexible, stranded wire for point-to-point and sub-panel wiring. Non-inflammable "spaghetti" covering. In black, yellow, green, red and brown; a color for each circuit. Put up in 25-ft. coils.



### Celatsite Battery Cable

— a silk-covered cable of vari-colored Flexible Celatsite wires, for connecting batteries to set. Prevents "blowing" of tubes; gives your set an orderly appearance.



Send for Complete Acme Wire Products Folder  
ACME WIRE CO., DEPT. S, NEW HAVEN, CONN.

## ACME WIRE

MAKES BETTER RADIO

SAY YOU SAW IT IN QST—IT IDENTIFIES YOU AND HELPS QST

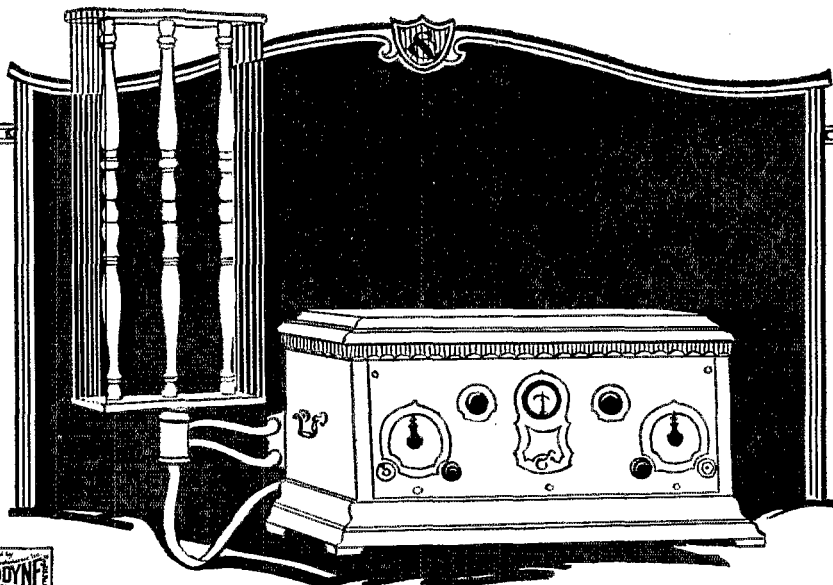

## *This Receiver has* **many "UNIVERSAL" FEATURES**

These features, perfected by the Stromberg-Carlson Engineers, give an adaptability to the receiver which insures successful operation under all of the varying conditions of location and installation.

In this model by an ingenious arrangement of circuits and wiring, a loop may be employed—instead of an outside aerial—thus making possible successful operation in steel buildings and other locations where a fixed antenna is impractical.

Any of the various sources of operating power, socket or battery or a combination of both can be utilized with equal facility. All of the new power tubes—the new external power amplifiers, and any type of reproducer—will operate efficiently with this magnificent new instrument.

No. 601 Receiver, treasure chest type, 6-tube; totally shielded; dual control; Equipped with voltmeter; solid mahogany.

Furnished in both regular and Universal models.

Prices, less accessories:

	East of Rockies	Pacific Coast	Canada
Receiver, Regular .....	\$210.00	\$225.00	\$290.00
Receiver, Universal (Loop extra)	225.00	240.00	315.00
No. 101-A Loop Outfit .....	22.50	25.00	31.50

**STROMBERG-CARLSON TELEPHONE MFG. CO., Rochester, N. Y.**

# **Stromberg-Carlson**

# The Choice of Wireless Operators Everywhere

Improved Martin

Reg. Trade Marks  
Vibroplex  
Bug  
Lightning Bug

## VIBROPLEX

The World's Greatest Bug

For Continental,  
Morse or  
Navy  
Codes

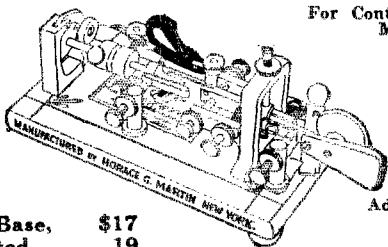

Over  
100,000  
Users

Adjustable  
To Any  
Desired  
Speed

Japanned Base, \$17  
Nickel-Plated, 19

The Improved Vibroplex is the choice of Wireless Operators everywhere because it is **EASIER, QUICKER and MORE ACCURATE** than the old key.

It transmits with amazing ease. **CLEAR, CLEAN-CUT** signals at any desired speed. Saves the arm. Prevents cramp, and enables any operator to send with the skill of an expert.

### Special Radio Model

Equipped with Large Specially Constructed Contact Points. Requires no relay **\$25**

No radio station complete without an Improved Vibroplex. Easy to learn. Get an Improved Vibroplex NOW! Liberal allowance on your old (Martin) bug—any model. Sent on receipt of price. Money order or registered mail.

**THE VIBROPLEX CO., Inc., 825 Broadway, New York**

Builders and Operators of America's First Radio-Operated Automobile

"THE AMERICAN WONDER TOUR"  
**Francis P. Houdina Co.**  
1477 BROADWAY  
New York

Address Reply to:  
Apr. 30th, 1926  
Greenville, S. C.  
General Delivery

J. E. Albright & Co.,  
825 Broadway  
New York City  
Attention Mr. La Hill

Dear Sir:  
This is to advise that two VIBROPLEX are used by STATION 2XAX, the portable radio transmitter used to control "America's First Radio Operated Automobile."

These instruments have been in use for some time, and have pleased with the results. Our operators are well pleased to handle because it is much easier and quicker to handle this radio operated driverless car, by using these instruments instead of the old type keys. We also find these instruments constructed of best materials which enables them to withstand the various weather conditions to which they are subjected.

It is with pleasure that we thank you for the opportunity of using an instrument of this kind, because we are always ready to give any manufacturer of products of their co-operation, of approval, not because of a policy that is bound to give satisfaction: Workmanship, High grade materials, and accuracy.

We wish to thank you again for your attention and wish to "boost" the VIBROPLEX thruout the balance of our continental tour, with your approval.

We beg to remain  
Respectfully  
**FRANCIS P. HOUDINA CO.**  
F. P. HOUDINA, Pres.

## THE SUPER-SYNC

The Synchronous Rectifier That Can Be Filtered

When filtered, the Super-Sync delivers a pure D. C. tone which is often mistaken for battery plate supply.

The Super-Sync can be filtered with absolutely no sparking at the brushes. The Super-Sync will handle as high as 4000 volts at 250 M.A. without

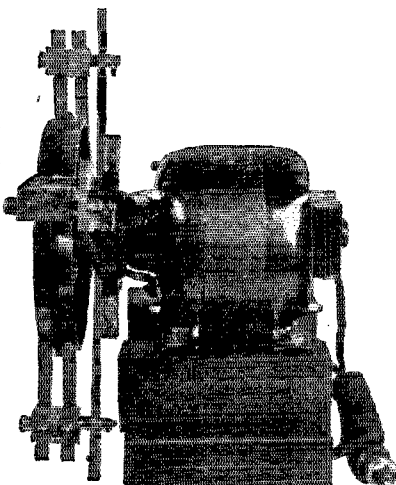

giving the least trouble. This is usually sufficient to supply the ordinary amateur transmitter.

The commutator is turned at a synchronous speed by a 1/4 H.P. synchronous motor. This motor can be supplied for either 110 or 220 volts 50 or 60 cy.

PAT. PENDING

PRICE \$75.00 F. O. B. ST. LOUIS

**MARLO ELECTRIC CO., 5241 Botanical Ave., St. Louis, Mo.**



# Announcing!



The DeForest Radio Company takes pleasure in announcing the appointment of the Transmitting Equipment Company as its exclusive selling agents for the De Forest transmitting and rectifying tubes in the United States east of the Mississippi River.

The Transmitting Equipment Company is under the management of W. J. Halligan, formerly Vice-President and sales manager of the Tobe Deutschmann Company of Boston. Mr. Halligan has for years been active in amateur affairs, and at one time was Division Publicity Manager of the A.E.R.L. for New England. Associated with him are several other men all of them amateurs and men of wide technical training, whose services will always be available to the readers of QST.

The TECO line of radio apparatus includes, in addition to the De Forest tubes, mica condensers, 3000-volt filter condensers, transmitting inductances and short wave plug-in coils and transmitting radio frequency chokes. We have also just completed the design of an unique short-wave set. Literature describing it, and also technical specifications of the De Forest tubes, will be mailed upon request.

## THE DE FOREST HR RECTIFYING TUBE

The only high voltage rectifying tube on the market. An entirely new development of the De Forest laboratories. Will safely pass 250 milliamperes.

### DV 9R RECTIFIER

Among the many engineering achievements of the De Forest laboratories is the DV 9R, a rectifying tube worthy of the name. It is similar in design to the Type HR, but is intended for lower power operation.

Type DV 9R  
\$8.50.

### DV 9 POWER TUBE

In answer to the popular demand for a low power transmitting tube for use on the short waves, the new DV 9 power tube is here introduced at the reasonable price of \$9.

Type DV 9  
\$9.

### H TUBE

The tremendous response which followed the first announcement of the now famous De Forest H tube proved to its designers that the transmitting amateur appreciates this attempt to provide a highly efficient tube at a reasonable price. No other tube made is so well suited to short wave transmission. Provided with the proper grid resistances, the H tube will perform with amazing efficiency. If present H tube owners are not getting all that they should from their tubes, the Transmitting Equipment Company will be delighted to help them.

Type H  
\$18.

## Transmitting Equipment Co.

19 Stuart Street

BOSTON, - - MASS.

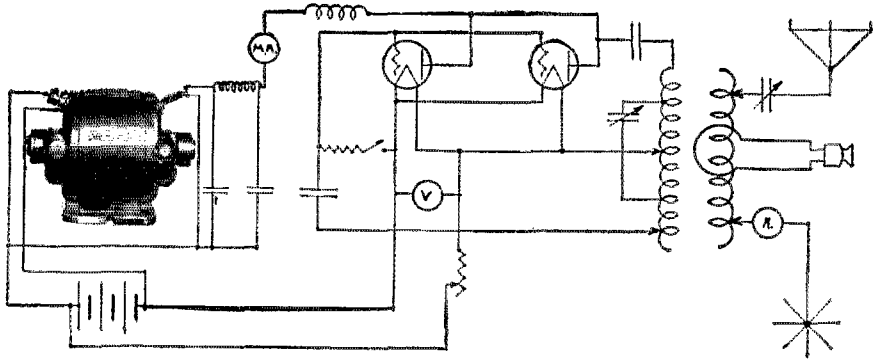

## ELECTRIC SPECIALTY COMPANY

Manufacturers of Motors, Generators, Motor-Generator Sets, Dynamotors and Rotary Convertors for all Radio purposes. Have you got your copy of Bulletin 237B and ESCO Filter facts? If not, write for them.

TRADE 'ESCO' MARK

225 South Street,

Stamford, Conn.

"ESCO" Engineers will help you solve that Generator problem

## CARTER

New "SHORT" Jacks

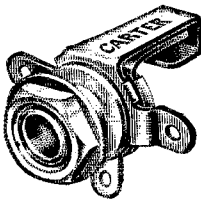

(FULL SIZE)

Open Circuit 25c ea.  
Closed Circuit 30c ea.

Fits any plug. Smallest jack made. Fits in small space. Terminals far apart which makes soldering easy. Heavy bakelite insulation eliminates short circuiting or leaks. Sleeve terminal is marked +. Strong heavy springs will last as long as your set. Insulators for mounting on metal panels 10c extra per jack.



Any dealer can supply

In Canada — Carter Radio Co., Limited, Toronto



## Preferred/ The MUSICONE

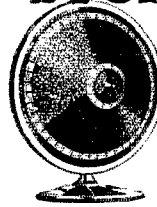

above all other loudspeakers—  
production capacity taxed—  
replacing all types by the  
thousands—

\$14.75



yet less than \$15.

## CROSLLEY MUSICONE

Write Dept. 18 for Booklet  
THE CROSLLEY RADIO CORP.  
Cincinnati, Ohio  
Prices slightly higher west of the  
Rockies.

Dealers sell Crosley Radios from  
\$9.75 to \$75. and the Musicone  
Loudspeaker at \$14.75

# Mr. Laurence M. Cockaday

Technical Editor says:

“Always use ‘B’ batteries with low internal resistance values”



“QUALITY reproduction,” says the Technical Editor of *Popular Radio*, “is obtained by using some non-distorting form of amplification, such as impedance or resistance coupling or high-grade transformer coupling. Resistance values are so important that you should always use ‘B’ batteries with low internal resistance values.”

Mr. Cockaday is shown above tuning in on a western station with his new LC-26 receiver, a long-distance receiving set which he has just announced. It has a laboratory range of 2,700 miles—New York to Los Angeles. Note the Ray-O-Vac batteries which he uses.

Ray-O-Vac batteries have the lowest internal resistance of any dry cell battery made. That is why they are always found in the laboratories of men like Mr. Cocka-

day, who have made and are making radio history—such men as Dr. Lee de Forest, “the father of radio broadcasting;” Charles V. Logwood, the first man to hear sound transmitted by radio and Chief Research Engineer of the Electrical Products Manufacturing Company; and Joseph D. R. Freed, President of the Freed-Eisemann Radio Corporation, the world’s largest makers of Neutrodyne receiving sets.

Give your apparatus the same chance to work at its best, as these men give theirs. Install Ray-O-Vac batteries, increase your set’s range for both transmission and reception and get clearer tone at any distance, without changing a thing but “B” batteries.

Ray-O-Vac batteries cost no more than ordinary batteries. They have low internal resistance because they are made by a special formula. That same formula is also the cause of the extraordinary *staying power* of Ray-O-Vac batteries.

Your regular supply houses can furnish you with Ray-O-Vac batteries. Ask for them by name. If you have any trouble getting them, write us for name and address of a nearby dealer who can supply you.

**FRENCH BATTERY COMPANY**  
Madison, Wisconsin



Ray-O-Vac “B” batteries in all standard sizes, both flat and upright.

Ray-O-Vac “A” batteries recuperate during rest periods, lasting longer and giving excellent reception.

Ray-O-Vac 4½ volt “C” batteries with 3 variable terminals give voltage adjustments of 1½, 3 and 4½ volts.

# Essential to Better Radio Sets



Patented  
July 23, 1925  
May 2, 1911



Patented  
July 23, 1925  
May 2, 1911

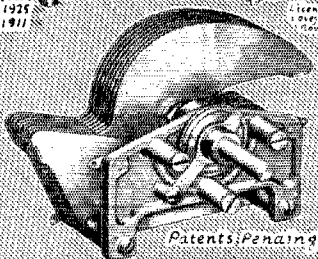

Patents Pending

Radio sets of today are very simple when compared to those of yesterday. This simplification has only been achieved by the finer, more delicate and more efficient parts that go into the makeup of the set.

Benjamin Radio Products have set up such high standards that many of the country's greatest radio authorities have continually advised and used Benjamin Radio Parts in their newest and best radio creations. They are essential to better radio sets, being built for the years to come.

Improve your work—sharpen the selectivity, increase the sensitivity, and intensify the volume of your old and new radio sets with Benjamin Radio Parts.

Send for the free instruction folder on our latest 3 and 5-tube hookups. These are by one of the best known radio authorities in the country. There are also other radio helps to be had for the asking that will interest you and prove valuable.

**Benjamin Electric Mfg. Co.**  
120-128 So. Sangamon Street  
Chicago

New York: 247 W. 17th St.  
San Francisco: 448 Bryant St.

Manufactured in Canada by  
the Benjamin Electric  
Mfg. Co. of Canada,  
Ltd., Toronto  
Ontario

# BENJAMIN

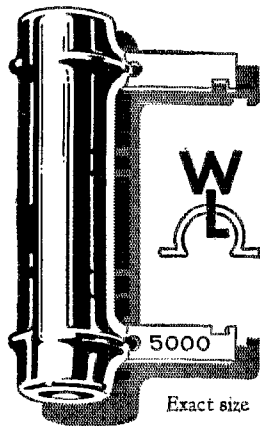

Exact size

## Ward Leonard Adjustable Resistors for building "Raytheon" and "Amertran" Plate Supply Circuits (Ask for the Vitrohm Resistor Kit)

Resistors are made in small units so you can try different combinations to find the amount of resistance that gives best results in your circuit.

Useful for other radio experimenting.

There are eight units in the Vitrohm Resistor Kit, of assorted values, totalling 21,750 ohms. They are wire wound, vitreous enamelled; no carbon or graphite. Hard to break but easy to use. Handy soldering lugs. Instructions for use and mounting included.

Sold by

**R. H. McMann & Co., Inc., 122 Chambers Street**  
**Morison Electrical Supply Co., 15 East 40th Street**  
**NEW YORK**

**20th Century Radio Co., 102 Flatbush Avenue**  
**BROOKLYN**

753-1-2

## QST Oscillating Crystals

We are at your service to grind to your specified frequency quartz crystals, accurate to one tenth of 1%. We are specialists in grinding crystals for High frequencies. (7000 to 10000 Kilo-cycles)

We ground the high frequency crystals for the WILKINS and BYRD ARCTIC EXPEDITIONS, and have performed wonderfully.

ATTENTION AMATEURS

We are desirous of securing 6 AMRAD 4000-1 "S" Tubes in exchange for grinding service. If you have some of the above tubes write us.

**Scientific Radio Service**  
**Box 86, Dept. B, Mount Rainier, Maryland**

# .000125MF. S. L. F.

for Short Wave Work

Type  
374-B

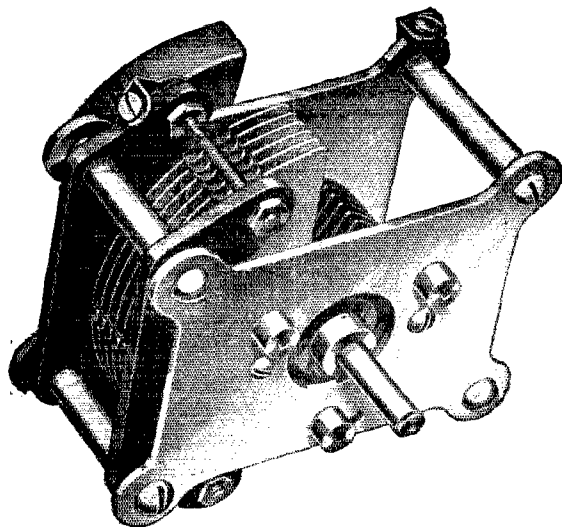

Price  
\$3.75



The General Radio Company has endeavored to make it possible for the experimenter to obtain its products with a minimum of effort. A careful selection of distributors and dealers has been made. They are best fitted to serve you. If, however, you are unable to obtain our products in your particular locality they will be delivered to you, direct from the factory upon receipt of list price.

In receiving on short wavelengths there is need for a well made condenser of low capacity with plates correctly shaped to assure ample separation of stations.

To meet this need the Type 374-B has been designed which has a capacity of .000125 MF.

The Type 374 condensers are similar in general construction to the Type 334 condensers except that the rotor plates are shaped to give a S. L. F. curve.

Type 374 condensers are available in all standard capacities.

Write for Bulletin 924-Q.

GENERAL RADIO CO.,

Cambridge, Mass.

# GENERAL RADIO

INSTRUMENTS

"Behind the Panels of Better Built Sets"

**ORIGINATED** and developed by Weston, Model 425 Thermo-Couple Type Ammeter eliminates all the numerous difficulties of measuring of Antennae of pansion by the "hot wire current type".

# A Noteworthy Contribution to Radio Transmission

**WESTON**  
Thermo-Couple Ammeter

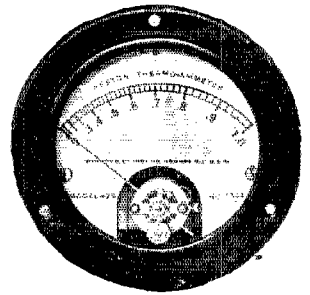

Model 425 perfectly solves the problem of the measurement of high frequency current, will measure accurately and with equal facility alternating currents of low frequency and is particularly flexible on D. C. Antenna Ammeters are essential for transmission, without the risk of distance or of transmission—radio enthusiasts everywhere depend upon Model 425 Thermo-Couple type for accurate results. For further information request Circular "N".

**WESTON ELECTRICAL INSTRUMENT CORPORATION**  
158 Weston Avenue, Newark, N. J.

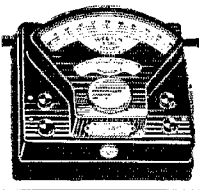

## STANDARD THE WORLD OVER

# WESTON

Pioneers since 1888

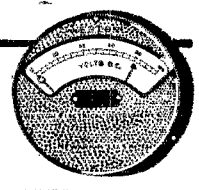

### B-Power Unit

Specification No. 1582  
For Standard Raytheon Tubes  
\$11.00 List

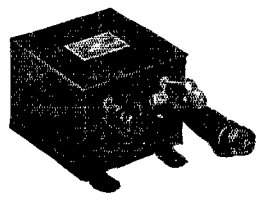

A distinct advancement in B-Eliminator construction—the new Dongan B-Power unit, sturdily built into a handsome steel case, assures the most perfect operation of your set with the Raytheon Type-B Full Rectifying Tube.

Also Dongan Transformers and Chokes for use with R. C. A. and other proved types of Full and Half-Wave Tubes.

Order from your dealer or send money order to us direct. Send for information on our special transmitting transformers.

**Raytheon Tubes \$6.00 List**

Transformers and Chokes for the new B H Raytheon Tube now available

**Dongan Electric Manufacturing Co.**  
2999-3001 Franklin St., Detroit, Mich.



### THREE "E" STRAIGHT LINE RHEOSTAT

Perfect Control of Filament Temperature  
Gives you a fine, smooth, dependable variation of filament temperature. Runs smoothly, is absolutely NOISELESS, and once set, "stays put!" Controls volume smoothly, and without distortion, over the entire range. Equally efficient for short and long wave sets. By all means secure this precision instrument at once. Ask your dealer or order direct. Price \$2.50 Postpaid.

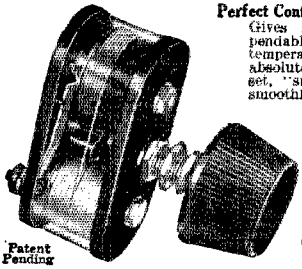

Illus. 3/2 Size 6-15-30 Ohms



**ELECTRICAL ENGINEERS EQUIPMENT CO.**  
Radio Division  
708 W. Madison St., Dept. 7 Chicago, Ill.  
Information on Request

## HERCULES AERIAL MAST

We pay freight  
Mail the Coupon  
20 Ft. \$10. 40 Ft. \$25. 60 Ft. \$45.  
All Steel Construction  
Complete with guy-wires etc.

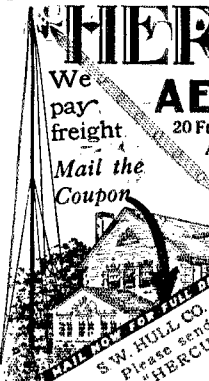

2045 East 79th St., Cleveland, Ohio  
S.W. HULL CO. Dept. D  
Please send free the full details about the "HERCULES" Aerial Mast.  
NAME \_\_\_\_\_ STREET \_\_\_\_\_ CITY \_\_\_\_\_

# You'll Use Karas Condensers In Your Short Wave Set

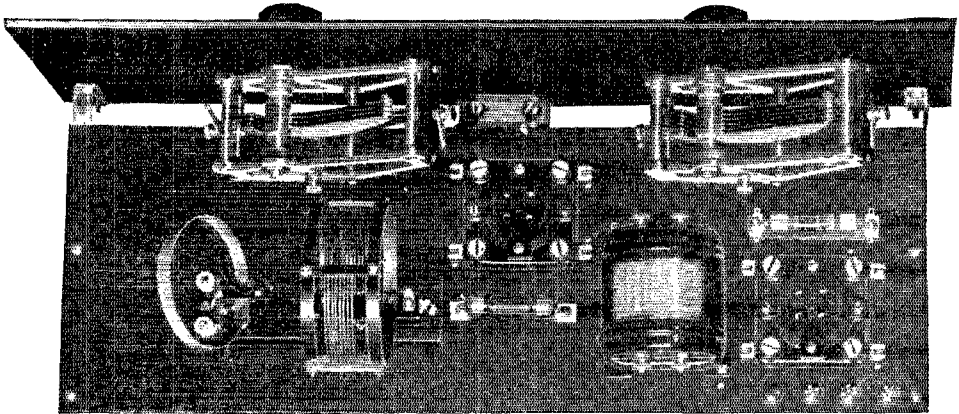

## Put in a Karas Transformer Also

Karas Orthometric condensers with their straight frequency line tuning characteristics are the choice of the leaders in short wave work. Both theoretically and in actual use they have the lowest possible losses—at any frequency. Stations are spread evenly by kilocycles from end to end of the tuning range.

A Karas Harmonic transformer will pass the greatest possible power from detector to audio stage—on any beat note you choose—with the least distortion if you're using voice. Make it an all-Karas job and get the benefit, in the head phones, of every bit of energy reaching your antenna.

5-plate Orthometric (.0001) price \$6.50;  
7-plate (.00014) price \$6.50; 11-plate (.00025) price \$6.50; 17-plate (.00035) price \$6.75; 23-plate (.0005) price \$7.00.



Karas Harmonik Transformer \$7.00

### Order Through Dealer or, Direct on This Coupon

Karas Condensers in the 23, 17 and 11 plate sizes are sold by good Radio Parts Dealers in most cities. The 7 and 5 plate sizes are not so widely stocked by dealers. Orders will be filled direct, or may be placed through your dealer and his jobber. If you prefer to order direct, use this coupon. Send no money. Just pay the postman the price plus a few cents postage.

**KARAS ELECTRIC CO.**  
Manufacturing Plant: N. Rockwell St.  
Offices: 1070 Association Building  
Chicago, Ill.

Karas Electric Co., 1070 Association Bldg., Chicago.

Please send me.....Karas Harmonik Transformers and

.....Karas Orthometric Condensers.  
size as checked below. I will pay the postman the price plus postage upon delivery. It is understood that I have the privilege of returning these condensers and transformers for full refund any time within 30 days if they do not prove entirely satisfactory.

..5 plate; ..7 plate; ..11 plate; ..17 plate; ..23 plate.

Name .....

Address .....

If you send cash with order, we'll ship condensers and transformers postpaid.

# A Point on Your Dial For Every Station!

## METRALIGN

(Straight Line Tuning)

The Only Condenser  
That Prevents Jamming

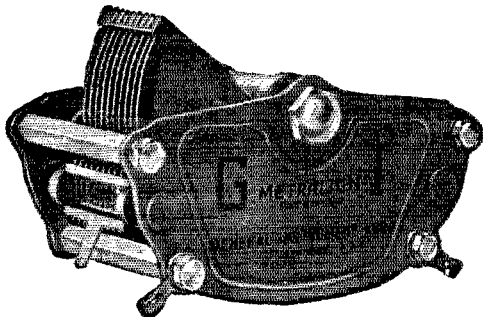

Straight Line Capacity Condensers crowd stations on the low wave lengths. Straight Line Frequency Condensers crowd stations on the high wave lengths. Straight Line Wave Length Condensers crowd stations on both high and low wave lengths.

## METRALIGN

(Straight Line Tuning)

Is the only condenser which is equally efficient on both high and low and intermediate wave lengths—and by spreading out the stations evenly over the entire band it naturally makes any receiver much more **SELECTIVE**.

The METRALIGN (SLT) is rigid and compact, much smaller than other condensers, yet possesses the accuracy and precision of laboratory standards.

The METRALIGN (SLT) Condenser makes it possible for the owner of any type set to bring in stations never heard before.

**Free** We have prepared a very useful booklet, written in everyday language, covering everything you want to know about condensers. It's **FREE**—Write for it.

### GENERAL INSTRUMENT CORP.

Manufacturers of "Bureau of Standards" Variable Primary Condensers

477 Broadway, New York City

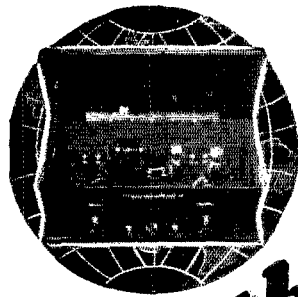

# Cover the WORLD with

The A. R. S. Co. Standard Short Wave Receiver  
(10 to 250 Meters)

A QUALITY INSTRUMENT DESIGNED AND BUILT EXPRESSLY FOR DEPENDABLE EFFICIENT RECEPTION ON THE HIGH FREQUENCIES.

Send for descriptive circular.

PRICE—Complete with full set of R. E. L. plug in coils in mahogany cabinet. **\$38.00**

Receiver with AERO PLUG IN COILS - - - - - **\$46.00**

For The

# TRANSMITTING Amateur

The A. R. S. Co.

NO LOSS INDUCTANCE

KILN DRIED maple insulation.

Adjustable coupling.

Maximum energy transfer.

20 & 40 meter inductance **\$4.95**

80 - 200 meter inductance **\$5.45**

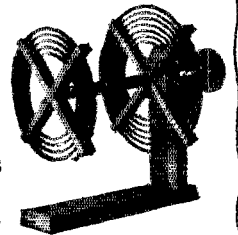

REDUCED PRICES

Transmitting & Receiving Apparatus

Full line of

ACME-THORDARSON-JEWEL-WESTON-RCA

PYREX-FLERON-CARDWELL-HAMMARLUND

NATIONAL-ALLEN-BRADLEY-R. E. L.

FARADON-TOBE DEUTCHMANN-GENERAL RADIO

WARD LEONARD-AERO PRODUCTS-FEDERAL-Etc.

Send for our new catalogue.

# AMATEUR RADIO SPECIALTY COMPANY

77 CORTLANDT ST.  
NEW YORK CITY





# Use Dubilier condensers in your Raytheon eliminator

Type PL 91—A high voltage buffer condenser for use across the transformer secondary—price \$2.00.

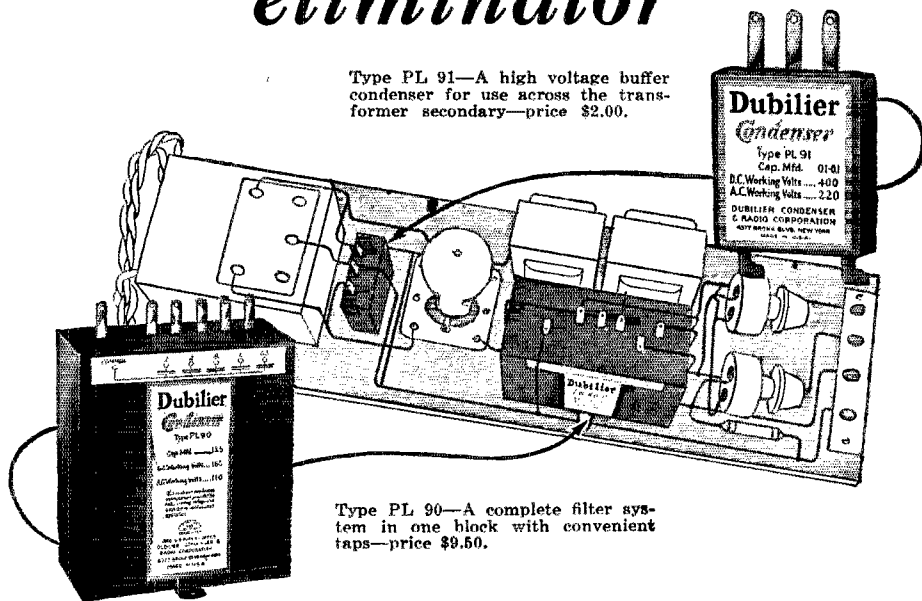

Type PL 90—A complete filter system in one block with convenient taps—price \$9.50.

These new Dubilier condensers will make your Raytheon "B" Battery eliminator better.

Type PL 91, is a .1—1 buffer condenser to be used across the secondary of the 110 volt input transformer.

Type PL 90, contains all condensers needed in the filter circuit and is tapped at 2, 2, 8, 1 and .5 mfd.

Dubilier condensers are specially designed and constructed to withstand the high voltages used in B battery eliminators. They are the finest condensers obtainable for this purpose.

Send 10c for our booklet which shows fourteen ways in which you can improve your set by simple application of condensers.

4377 Bronx Blvd., New York, N. Y.

# Dubilier

**CONDENSER AND RADIO CORPORATION**

# YOU NEED THESE PLUG-IN COILS

Note the many advantages of these better and different coils listed below and try to do without them.

1. Positive contact is secured through General Radio plugs and jacks.

2. With 3 Coils, continuous, gapless range is secured from 140 to 16 meters. One of the 20-40-80 meters amateur bands is located in the middle of the tuning range of each of the 3 coils. (For this a SFL Condenser, 140 mmfd. max. cap. is essential.)

3. Operation of regeneration condenser has no effect on the tuning; the 2 controls are completely independent.

4. Antenna coupling is adjustable; by a primary coil

and not through a condenser. Secondary coils are specially constructed so that setting of primary coil does not need to be changed when secondaries are exchanged.

5. Coils are space-wound solenoids on skeleton frames.

6. Both tickler and antenna coil are at filament end of the secondary.

7. These coils cover the 3 U. S. Amateur Bands, all European Amateur Bands, Short-Wave Broadcast, U. S. Naval and Commercial Short-Wave Stations, etc.

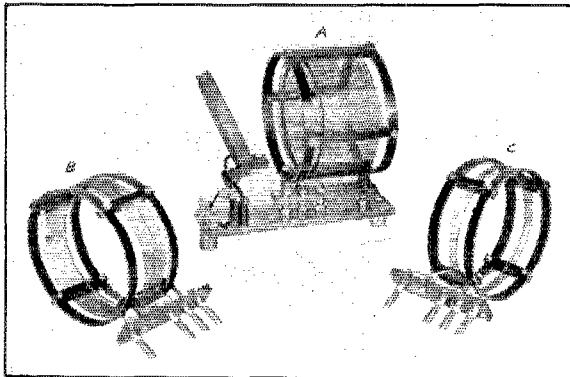

The Kit Illustrated Covering 15 to 133 Meters Complete **\$12.50**  
 Coil No. 4, 125-250 M Price \$4.00  
 Coil No. 5, 235-550 M Price \$4.00

These coils are essential to the most efficient operation of your station. Order your TODAY.

**AERO PRODUCTS INCORPORATED, Dept. 16, 1768-1772 Wilson Ave., Chicago, Ill.**



**FILTER CONDENSERS**  
 To Suit Operating and  
 Space Requirements

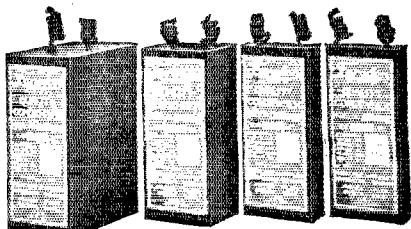

**THE SERIES 3700 UNITS**

cover a wide voltage range with a high factor of safety in insulation resistance. When used in groups they assemble compactly.

**FARADON CONDENSERS**

if unobtainable promptly through your regular supply house may be ordered direct. State capacities, flash test and operating voltage requirements, and space available.

Quotation on special blocks furnished manufacturers on receipt of specifications.

**WIRELESS SPECIALTY APPARATUS CO.**  
 Jamaica Plain, Boston, Mass., U. S. A.

*Nineteen Years Specialization in the Radio Field*

## Where Radio Training is a Business

For 15 years we have specialized in training young men for the radio operating and service fields. Complete course four months on spark, arc, V. T. transmitters, including crystal frequency controls, leading to first class license.

Send for booklet "Opportunities in Radio"  
**Y. M. C. A. RADIO INSTITUTE**  
 159 East 86th St., New York City

## Edison Element Storage "B" Batteries

Easily recharged. Cannot be harmed by shortcircuits or overcharging. Absolutely no hum or other noises. Low internal resistance. Guaranteed 2 years.

100 volt, \$12.50. 140 volt, \$17.00. Edison elements and parts in stock.

Send for list.

**J. Zied, 904 N. 5th St. Phila., Pa.**

*Laboratory Product*



**CRESCENT  
 LAVITE  
 RESISTANCES**

*For Distortionless Amplification*

Dual resistance for DeForest "H" tube \$8.50. Consists of two units mounted on bakelite and connected in parallel. Please specify if your "H" tube requires 50,000 ohms or 20,000 ohms. All amateur apparatus in stock. Let us drill and engrave your panels.  
**CRESCENT RADIO SUPPLY CO., 1 Liberty St., Jamaica, N. Y.**

\$1.50 lower half \$8950 Receiving Set, consists of three Rheostats, 1 three pole double throw Cam Switch, 1 D Coil Variometer, binding posts, gang pin rack, aluminum panel brackets, 1-3 gang standard sockets on shock absorbers. We bought \$10,000.00 worth of United States Government Department Radio Transmitting Receiving Sets and Parts. Get our new and latest reduced price list for a 2c stamp. Mail orders sent all over the world.

**WEIL'S CURIOSITY SHOP,**  
 20 South 2nd St., Philadelphia, Pa.

# Specified wherever tone quality is paramount

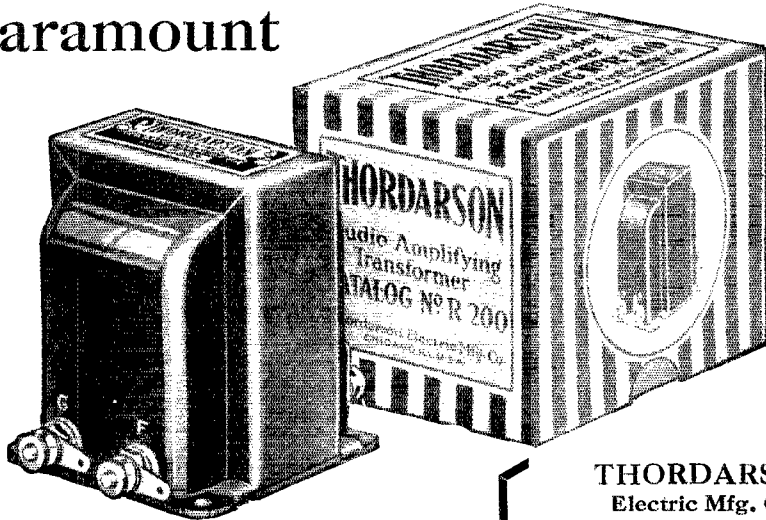

## THORDARSON R-200 Amplifying Transformer

The proof of the pudding is in the eating.

The satisfaction you derive from your radio set depends upon its fidelity of reproduction.

Since the institution of broadcasting, Thordarson transformers have been the great outstanding factor of faithful reproduction in a multitude of receivers.

That is why to-day you find more Thordarson transformers in the receivers of leading manufacturers than all competitive transformers combined.

Thordarson R-200 is available at reliable dealers everywhere at a cost of eight dollars.

**THORDARSON**  
Electric Mfg. Co.

### Silent B-Eliminators Transformers & Chokes

We unhesitatingly recommend the Raytheon type B-eliminator for quiet and efficient operation on all types of receivers. Thordarson transformers and chokes are available for this circuit.

#### TRANSFORMER

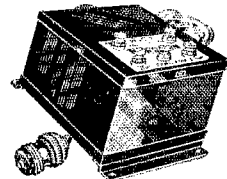

**R-195**  
Price  
**\$7.00**

Larger in capacity—will not heat up in continuous service. Separable plug, 6 foot cord attached. At reliable dealers everywhere.

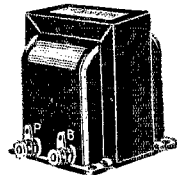

**CHOKE**  
**R-196**  
Price  
**\$5.00**

Completely shielded and mounted in steel case. Binding posts at base for neat assembly. Capacity 60 milliamperes, 50 henries inductance.

*Write for assembly instructions*

**THORDARSON ELECTRIC MANUFACTURING CO.**  
*Transformer specialists since 1895*  
**WORLD'S OLDEST AND LARGEST EXCLUSIVE TRANSFORMER MAKERS**  
**Chicago, U.S.A.**

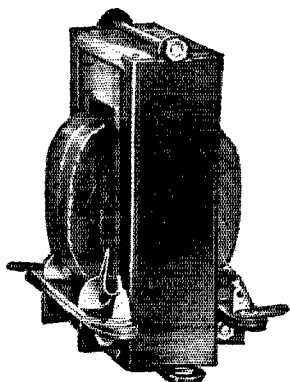

PACENT SUPERAUDIOFORMER  
Cat. 27, Price \$6.00

## The Last Word In Transformers!

THE SUPERAUDIOFORMER No. 27 is the result of several years of engineering research in the Pacent Laboratories towards the development of a "man's size transformer to do a man's size job".

That the SUPERAUDIOFORMER is a complete success - in every way - is attested by the fact that it has been selected as the most perfect transformer by the engineers of the oldest and largest engineering laboratories in the world.

You will find that the SUPERAUDIOFORMER will revolutionize the performance of your set - especially in the reception of music: Every note of the entire musical range - from the highest to the lowest - is brought in in its natural, unmarred, undistorted tonal beauty.

*There is no substitute for the SUPERAUDIOFORMER! Get one, TODAY, and enjoy real music. If your dealer cannot supply you, write to us direct.*

PACENT ELECTRIC CO., Inc.  
91 Seventh Ave. New York City

THE TUBE WITH THE SENSIBLE GUARANTEE



# A lucky break!

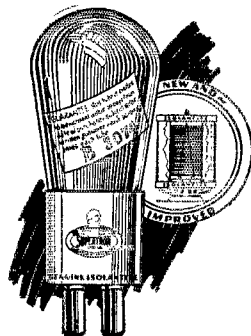

VIBRATIONLESS  
UNIFORM  
AND GOOD

"Granted—That All Radio Tubes Test Good Before They Are Shipped From Factory."

"But—Due to Ordinary Interior Construction, the Mere Handling of Tubes in Transit Invariably Disorders the Tube—"

"Therefore—If It Works After You Buy It—"

**It's a Lucky Break!**

The new and improved Supertrons are internally reinforced to withstand handling.

When you buy Supertrons you buy permanent quality as long as the Tube lives—and it lives longer than others.

Supertron Mfg. Co. Inc., Hoboken N. J.  
Export Dept. 220 Broadway N. Y. C.



**SUPERTRON**

THE TUBE WITH THE SENSIBLE GUARANTEE  
The Foremost Independent Tube in America

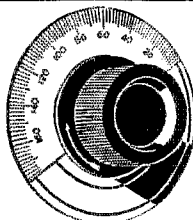

## SOMERVILLE DIALS

Used by QST readers since 1920,—now the *only* dial for direct calibration with call letters. Made of silver-plated and lacquered brass with a man-sized 2" knob of heat-proof thermoplastic. Truly distinctive. Transparent celluloid pointers... **\$1 31 for 10c**

Mention QST—Get 2 Rheostat Knobs to Match Free. Extra Knobs 10c.

Mail orders filled direct—Postpaid.

DEALERS send \$1.00 for introductory package-on business letterhead to get regular discount. No charge accounts.

MICA CONDENSERS, 10c Tested & Guaranteed within 5% Accurate. Sizes—.005, .002, .001, .00025 with Grid Clips.

F. R. PRAY & CO.  
Mrs. & Radio Wholesalers  
26a Brattle St., Boston

## RADIO OPERATORS WANTED

Radio Operators are needed on board ships sailing for Europe, The Orient, Africa, South America, etc. THE EASTERN RADIO INSTITUTE can train you quickly and thoroughly because:

MODERN and EFFICIENT METHODS  
THOROUGH yet Simple INSTRUCTION  
New and UP-TO-DATE APPARATUS  
THIRTEEN Years a RADIO SCHOOL

THE OLDEST, LARGEST, and MOST SUCCESSFUL school in New England. RECOMMENDED BY THE A. R. R. L.

Day or Evening Classes Start Every Monday.

Write for Illustrated Prospectus

**EASTERN RADIO INSTITUTE**  
899 BOYLSTON STREET  
BOSTON, MASS.

## Contents of Acme B-Eliminator Kit

Wiring Diagrams with  
complete instructions  
Baseboard  
1 Acme B-4—Transformer  
2 Acme B-2—30 Henry Chokes  
1 Acme Condenser Block  
1 Bradleyohm  
1 Raytheon Tube and Socket  
Wire

Price 39.50

Photo below of factory-made Acme B-Eliminator Type E-1—110 Volts, 60 cycle—  
Type E-2—110 Volts, DC \$20.00

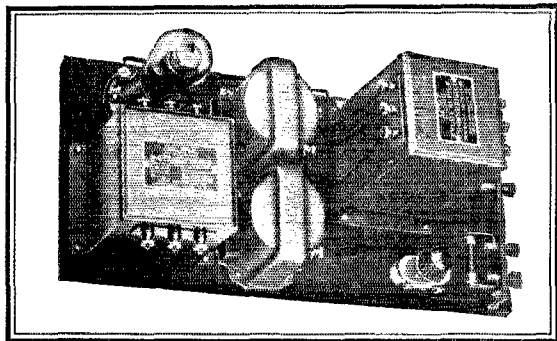

Acme B-Eliminator, assembled from Kit

Price  
\$50.00

## You can easily make this Acme B-Eliminator yourself

*The new Acme B-Eliminator Kit contains  
complete instructions and all the parts*

**G**ET one of the new Acme B-Eliminator Kits—take it home and lay out the full size diagrams on the table in front of you. It takes only a few minutes to fasten the parts to the baseboard and connect them up. All the parts are there and the baseboard, too, and easily-followed instructions that explain each step. It's as easy as rolling off a log. You fellows who have tinkered with radio will do it in less time than it would take to tell about it.

Then you'll have an Acme B-Eliminator and save the difference between the cost of the Kit and a factory-built Acme B-Eliminator.

### *Advantages of the Acme B-Eliminator*

You get better quality and more distance, more volume, and *no hum* and *no distortion*. You can be sure of that. Also the Acme B-Eliminator maintains its voltage at all times and you get voltages up to 180 volts which prevents any chance of over-

loading. It will supply sets using up to 10 tubes.

### *A permanent B-Supply*

When you invest in an Acme B-Eliminator you get a permanent B-Supply. No more running out to get new B Batteries. There's nothing to wear out—the Raytheon Tube used has no filament to burn out and will last for thousands of hours—the current cost is practically nothing.

### *Send coupon for both booklet and circular*

Send 10c for our booklet, "Amplification without Distortion," which will tell you some things about improving the quality of your radio reception, together with special free circular on the B-Eliminator Kit, or ask us to mail the free circular. Check the Coupon.

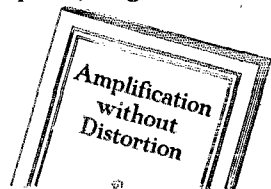

# ACME

~ for amplification

ACME APPARATUS COMPANY,  
Dept. E18, Cambridge, Mass.

- I enclose 10c for copy of your booklet, "Amplification without Distortion," and circular on the B-Eliminator Kit.
- Please send only free circular on B-Eliminator Kit.

Name .....

Street .....

City ..... State .....

# GROSS SHORT-WAVE APPARATUS PLUG-IN COILS

General Radio Jacks and Plugs used. Most efficient plug-in arrangement on the market.

Can be handled freely without fear of injuring coils, also making possible permanent calibration of set.

Minimum amount of dielectric insures lower losses resulting in stronger signals and sharper tuning.

Without question the most rugged receiving coil on the market.

Spaced winding insuring minimum distributed capacity.

Price for 80 Meter Band complete with Base (58 to 115 meters) \$5.50.

Price for 40 Meter Band (30 to 60 meters) \$5.50. Complete with Base. Separate coils for 20, 40 or 80 meters \$3.00.

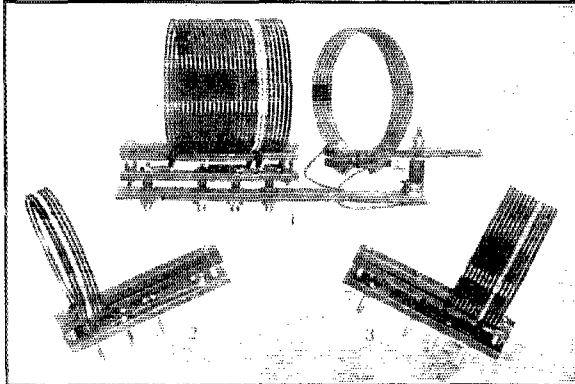

The Original Pancake Inductances for 20, 40, or 80 meters, \$5.00. Quartz Crystals, \$6.75. Transmitters of any power on hand. Send stamp for circulars describing full line of transmitting and receiving parts.

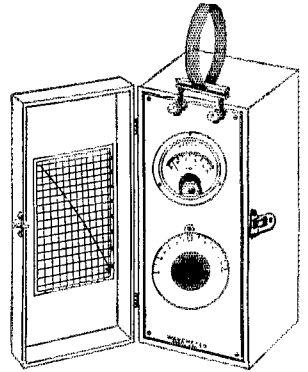

## GROSS WAVEMETER

Built into rugged and handsome cabinet, handy size, removable cover. Low-loss inductances and condenser insure a low resistance wavemeter. Separate curve for each coil checked against oscillating crystal. Accuracy better than 1% guaranteed.

Type L—with flashlamp indicator—for 20, 40, 80, meter bands, \$15.00; for 20, 40, 80, 200, meter bands, \$18.75.

Type G—with galvanometer—20, 40, 80, meter bands, \$30.00; for 20, 40, 80, 200, meter bands, \$33.75.

**J. GROSS & CO.,**

907 FOX ST., BRONX, N. Y. CITY.  
Laboratory, 30 Park Place.

# ELECTRAD

*New!*

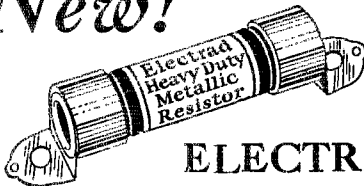

## ELECTRAD

### Heavy Duty Metallic Resistor

Specially developed for B eliminators and power supply units.

Special features are:

- 1—High current-carrying capacity.
- 2—Non-inductive. Accurate calibration.
- 3—Low temperature coefficient.
- 4—Resistance element fused to inside of Lavrock tube.
- 5—All standard high resistance sizes.

Ask your dealer for detailed Circular.

List price \$1.00; in Canada \$1.40

ELECTRAD, Inc.

428 Broadway, New York City

# ELECTRAD

# YAXLEY

## WALL SOCKET JACK

### The Radio Convenience Outlet For Radio House Wiring

More homes, apartments and hotels are being wired with Yaxley Wall Socket Jacks—a decided improvement in radio convenience outlets. Easily wired, in series or parallel, and substantially constructed. Mounts in smallest size outlet box.

Send for Illustrated Literature On Hook-ups

**PRICE EACH, \$1.00**

At all good radio dealers

**YAXLEY MFG. CO., Dept. Q**

9 So. Clinton St.,

Chicago, Ill.



## Are You Building a New Set?

Send for Jewell's New Radio Catalog—15-C  
Now on the Press

**JEWELL ELECTRICAL INSTRUMENT CO.**  
1650 Walnut St. - Chicago

# Cardwell

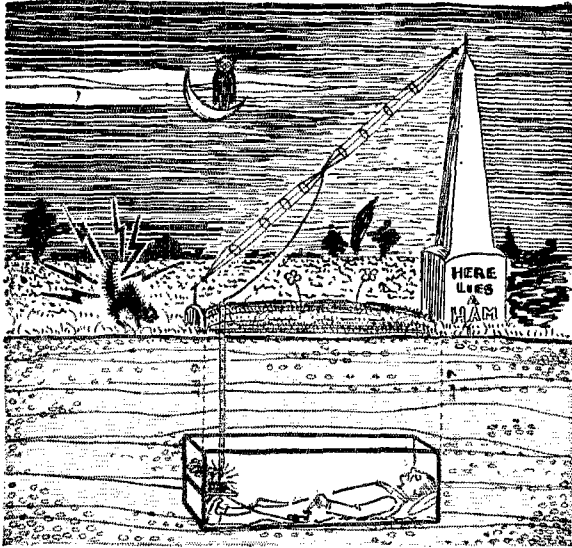

A CEMETERY  
makes the best  
permanent  
ground!

~but you can't keep  
the "ham" who uses  
Cardwell Condensers  
off the air

COMMANDER BYRD used Cardwell Condensers in all his airplane sets and in the KEGK Transmitter.

THE HOBBS Greenland Expedition uses Cardwell Condensers.

JOHN REINARTZ used Cardwell Condensers on the MacMillan trip.

*Wherever absolute reliability is a necessity, Cardwell Condensers are sure to be chosen!*

"There is no corner store in the Arctic"

THE new Taper Plate type E Receiving Condenser is designed to be practical rather than theoretically perfect, between straight frequency and wavelength. Full size plates, far heavier than ever used before, assure positive permanence of calibration. The type C gives a modified straight wavelength.

## Transmitting VARIABLE

Capacity Mmids	Type No.	Breakdown Voltage	Price
250	164-B	3000	\$ 7.00
440	147-B	3000	10.00
80*	197-B	3000	8.50
217*	157-B	3000	12.00
156	183-B	5250	15.00
297	166-B	7600	70.00
480	123-B	1400	5.00
480*	156-B	1400	7.00
980	137-B	1400	7.00

## FIXED

250	501	3000	\$ 4.50
440	502	3000	7.00
966	503	3000	10.00
250	504	5250	15.00

\*Has two insulated stators-capacity of each.

Type "C"	Type "E"	Capacity Mmids	Price
167-C	191-E	75	\$3.75
168-C	167-E	150	4.00
170-C	168-E	250	4.25
171-C	169-E	350	4.75
172-C	192-E	500	5.00

Send for booklet on 2QA Tuned Plate Tuned Grid Transmitter

Send for 36-page handbook and catalogue

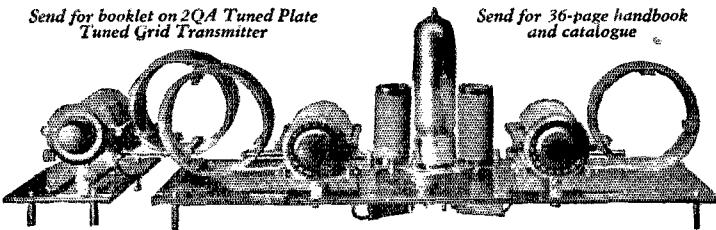

The Allen D. Cardwell  
Manufacturing Corp.  
81 PROSPECT STREET  
BROOKLYN, N. Y.

2QA gld QSO anytime 11:30 to 12 a. m.  
cs 4:30 to 5 p. m. E. S. T. QRK!

# Condensers

"THE STANDARD OF COMPARISON"  
SAY YOU SAW IT IN QST—IT IDENTIFIES YOU AND HELPS QST

# American Transformer Company

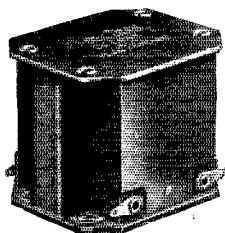

*AmerTran  
DeLuxe*

A reputation for fine transformers a quarter-century old! Today this high standard is more apparent than ever—For Radio recognizes AmerTran products as dependable leaders.

The new AmerTran DeLuxe Audio Transformer actually puts the development of the "audio side" ahead of existing acoustical devices. Faithful amplification with natural quality over the entire audible range is consistently obtained. This Audio Transformer sets a new standard of audio amplification.

As the receiving set of the future will be power operated, the American Transformer Company is now offering two units of the finest type—especially adapted to the use of the new  $7\frac{1}{2}$  volt power tubes in the last audio stage. These are the AmerTran Power Transformer and the AmerChoke. The Power Transformer also has filament supply windings for the power tube in the last stage and for the rectifying tube, and supplies sufficient plate current, after rectification, for the operation of the set.

Write today for interesting free booklet—"Improving the Audio Amplifier"—and price list.

AmerTran Products Are Sold Only at  
Authorized AmerTran Dealers

AMERICAN TRANSFORMER CO.  
178 Emmet Street Newark, N. J.

**Transformer Builders for  
Over Twenty-Five Years**



## TUBE TROUBLES!

Fifteen years of radio research is behind this new Magnavox wonder tube. Internal capacity only 4.5 MMF—oscillates freely on low wave lengths without unbasing. Amplification constant very high with low impedance. Price, \$2.50

THE MAGNAVOX CO., Oakland, California

# NEW MAGNAVOX

Non-Microphonic • Tube • Tipless

## BARGAINS!

1. RCA AUDIO TRANSFORMER, UV-712 (9/1 Ratio). The greatest Audio in the country. Recommended by KRUSE for peaked audio amplification. Originally sold for \$7.00. OUR PRICE, \$1.60.
  2. POWER RHEOSTATS FOR 5-watt tubes. Made by the Automatic Electrical Devices Co. 20c.
  3. KENNEDY CABINETS, solid mahogany, 8" x 6 $\frac{3}{4}$ ". Ideal for short-wave meters. 95c. Genuine CELERON panel, 7" x 9 $\frac{1}{4}$ ", 50c.
  4. FEDERAL PHONES, 2200-ohm. Every one brand new and in its original carton. Regular, \$7.00. OUR PRICE, \$2.00.
  5. HIGH-GRADE BALANCED CONDENSERS for that wavemeter. 45c.
  6. Plenty of CARDWELL 41-PLATE CONDENSERS. Easily rebuilt for your transmitter. \$1.25. We also have 11-PLATE CARDWELLS for your short-wave receiver. \$1.25.
  7. Are You Tired of Wearing the Cans? Here's your Chance to get a slightly shopworn LOUDSPEAKER for only \$1.95! (This lot includes Atlas, Musicox, Trinity, Spartan and others.)
  8. RADIO LUCKY BAG, containing an assortment of useful radio hardware, wrenches, small parts., etc., all for ONLY 25c. Don't fail to get yours!
- IN STOCK! Genuine RCA TRANSFORMERS for transmitting sets, as well other great ham bargains. Write for our list!

**Radio Surplus Corporation**

11 Stuart Street,

Boston



# SM "Plug-In B"

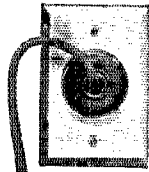

The Silver-Marshall type 850-B gives the highest power, the best regulation (constant output) regardless of number of tubes used, and greatest freedom from hum of any power supply you can buy. It will supply from 25 milliamperes at 300 volts to 90 milliamperes at 190 volts—ample for medium power transmitters.

The S-M "Plug-In B" will operate any type of set, no matter what it is. It will handle the largest power tubes (especially the new 6X171 soon due), and it will supply "A" and "C" power for audio amplifier tubes, too. In it is incorporated the S-M 331 Uni-choke—probably the greatest single advance made in "B" eliminator design.

The "Plug-In B" never runs down, never is noisy—and will give constant, ample power long after you've spent three or four times its cost for dry cells.

It is completely assembled, and requires the connection of a few wires, using only a screw-driver, to put it in operation.

Price, ready to connect, with genuine new type Raytheon tube, \$35.00.

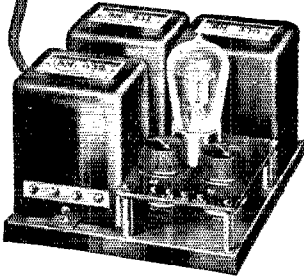

## Silver-Marshall, Inc.

858 West Jackson Blvd., Chicago, Ill., U. S. A.

# STRONG ~ as well as Accurate

*Guaranteed accurate within 10 per cent of marked capacity*

Accidents *will* happen—but it takes a worse blow than a fall on a cement floor to break a

## SANGAMO Mica Condenser

It is solidly molded in tough bakelite, with a velvety, smooth, rich brown finish. All corners are rounded to prevent chipping. High ribs give great mechanical strength. You might break one deliberately—with a hammer—but you will not even scratch the hard surface by dropping it.

This impenetrable bakelite armor protects the delicate condenser inside, and keeps it accurate forever. There are no exposed edges where moisture can creep in to create resistance. Rattling around in a spare-parts box does no harm. Spilled battery acid dries off harmlessly. An accurate part when bought, the Sangamo Condenser defies hot soldering irons, wet weather, knock-about use and blows from slipping tools. It *stays* accurate.

If you have never realized how much difference really accurate condensers make in tone, range and volume, try these condensers and enjoy better radio reception.

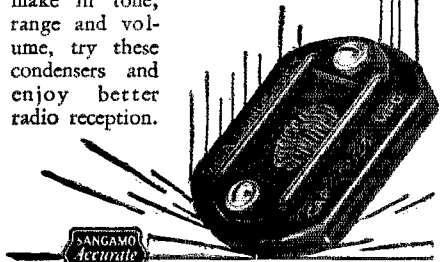

*Sangamo By-pass Condensers stand high voltages without breakdown.*

6332-5

## Sangamo Electric Company Springfield, Illinois

RADIO DIVISION, 50 Church Street, New York

SALES OFFICES—PRINCIPAL CITIES

For Canada—Sangamo Electric Co. of Canada, Ltd., Toronto  
For Europe—British Sangamo Co., Ponders End, Middlesex, Eng  
For Far East—Ashida Engineering Co., Osaka, Japan

# FROST-RADIO

This is the new **FROST-RADIO**  
Bakelite Rheostat **LIST 75c**

An air-cooled Bakelite base rheostat of superior construction and design; has ample heat-radiating capacity and is sturdily made, operates smoothly and noiselessly

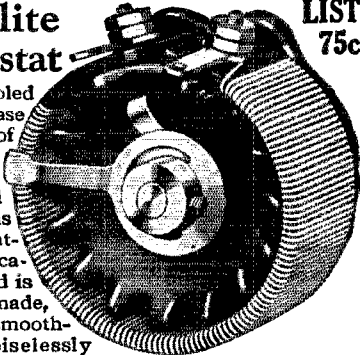

and positively will not heat up even after hours of use if proper resistance is selected. Equipped with **FROST-RADIO** Bakelite pointer knob and tinned soldering lugs. Made in 2½, 3½, 4, 5, 6, 7, 10, 20, 30, 50 and 75 ohm types, 75c, and 200 or 400 ohm potentiometer, 1.00. Ask your dealer which type is best for your set.

## HERBERT H. FROST, Inc.

160 No. La Salle St.  
New York City

CHICAGO, ILL.  
Los Angeles

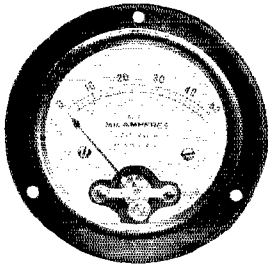

# Hoyt 30-F (flush) Meter

A new flush-mounting meter, with 3 in. diameter case, and the HOYT P-30 moving-coil movement, with jewelled bearings and resistance of 70 ohms per volt. The scale is 2½ in. long and is hand calibrated. This is the largest and most precise flush-mounting meter in a round case made by Hoyt, and is the last word for mounting on panels of large transmitting sets, and for power-supply units. Flange 3¼ in. diameter.

Price, in any scale to 500 volts or 50 amperes, \$10.00.

(Larger scales are not self-contained and are supplied at slightly higher prices. Also furnished as an A. C. meter.)

Send for new catalogue—"HOYT Switchboard Meters."

## BURTON-ROGERS CO.

26 Brighton Ave., Boston, Mass.

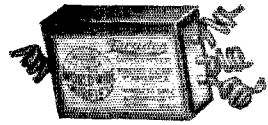

## What Size Grid and Plate Blocking Condensers?

You have always used .002 mfd. for blocking condensers but who knows that it is the best size for short waves? The builders of KFUH believe .000036 mfd. better for their tuned grid 'n plate circuit. Our UC 1015 condenser gives eleven different capacities between .0002 mfd. and .001 mfd. so you can select the best size for your set. Why not try them?

Price \$1.25 postpaid

## General Electric Gridleaks

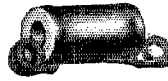

Brand new enameled porcelain G. E. Gridleaks in 5000 ohm and 10,000 ohm sizes for all tubes.

PRICES, 5000 ohm \$1.25, 10,000 ohm \$1.75. Postpaid.

Utility Radio Co., 80 Leslie St., East Orange, N. J.

FILAMENT AND  
PLATE TYPES



## Famous BH Transformers Transmitting Transformers

Our transformers are ideal for low wave transmission. Watch for "BH" Announcements.

Write for Our Catalogue  
Benjamin Hughes Electric Company

298 Lagachetiere St. W., Montreal, Can.  
Transformer Builders Since 1910

## "The Better Condensers"

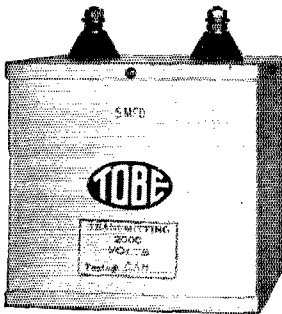

## New Model High-Tension Transmitting Condensers

This is a new model 2,000-volt transmitting condenser of 5 Mfd. capacity, equipped with special high-tension binding posts of heavy brass, equipped with nuts and washers. Cased in a solidly built silvered metal case 5 3/16" high by 5 3/4" wide by 5 7/8" deep.

The finest high-tension 5 Mfd condenser ever offered to Amateurs.

PRICE—\$14.75

If you cannot secure this condenser at your dealers, send check or money order and we will gladly ship to you, carriage prepaid.

## Tobe Deutschmann Co.

Cornhill

Boston, Mass.

# AEROVOX

"Built Better"

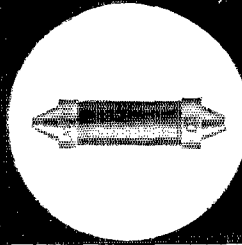

"Built Better"

LAVITE RESISTANCES

Used by over 200 of America's leading radio manufacturers. AEROVOX Fixed mica Condensers have been approved by M. I. T., Yale, Radio News, Popular Radio and Popular Science.

AEROVOX WIRELESS CORP.  
489-491-493 Broome St., New York

Branch Offices:

St. Louis, Mo. Switzler Trust Building  
Cincinnati, O. 304 Palace Theatre Bldg.  
Chicago, Ill. 23 W. Jackson, DuSoyne  
Boston, Mass. 212 W. Conant Street  
Los Angeles, Cal. 524 N. San Pedro St.

## Transmitters—Receivers Wavemeters

Write for Net. Quotations on Standard E-R-I. Transmitting and Receiving Equipment. Any Power Rating or for any Wavelength Range. Service on all Radio Equipment, Broadcasting, Amateur, Wavemeters, Power Control Panels, Short Wave Receivers, Master Oscillator Transmitters, Input Control Panels for Broadcasting and Our Special Speech Amplifiers for any Power Rating.

Your Parts employed it desired.

ENSALL RADIO LABORATORY

1208 Grandview Ave.

Warren, Ohio

"The Pioneer Builders of Short Wave Equipment"

AMATEUR

BROADCAST

COMMERCIAL

# why The ADVANCE "SYNC" RECTIFIER

is preferred by amateurs all over the world

1. The ADVANCE Sinc Rectifier actually does what any other rectifier claims to do.
2. Can be easily and quickly filtered.
3. Meets all requirements for heaviest duty.
4. Speedy starting because of Advance Bakelite wheel.
5. Requires no attention—always ready.

Its prevailing use in international transmitting is evidence that, although lower in price, the advance Sinc Rectifier is superior in quality.

Revolving disk is moulded bakelite six inches in diameter. Nickel plated brush holders with adjustable gauze copper brushes. Convenient control handle. Disk, aluminum brush arm support and brush holders perfectly insulated.

Price complete with Westinghouse  $\frac{1}{2}$  H. P. Synchronous Motor .... \$40  
Rectifying wheel with complete brush assembly and mounting ring to fit your own motor .... \$15

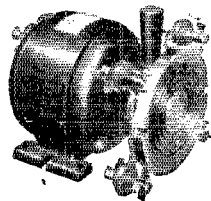

We Pay All Transportation Charges in U. S. A.  
**ADVANCE ELECTRIC COMPANY**  
1260-1262 West Second St., Los Angeles, Calif.

# New! Tone and Volume Control

Essential to thoroughly enjoy present day broadcasting. New high-priced sets feature tone control as their greatest improvement. You can have this new feature in your old set by attaching a Centralab Modulator Plug in place of the old phone plug. Takes but a moment—no tools required.

Gives any degree of tone volume from a whisper to maximum by simply turning the small knob on the plug. Static interference is reduced and programs come in clear and true with just the volume you most enjoy.

Order from your dealer, or mailed direct on receipt of the price, \$2.50

**Central Radio Laboratories**  
20 Keefe Ave. MILWAUKEE, WIS

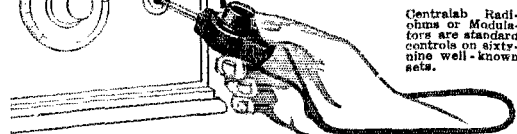

Centralab Radiobus or Modulators are standard controls on sixtysix well-known sets.

# Centralab

## Pyrex Insulators Triumph at the North Pole

Without exception on expeditions where life and death depend on radio communication, Pyrex Insulators have always been used. Commander Byrd selected Pyrex Insulators for the radio equipment on the ship "Chantier" and for the plane which he flew to the Pole.

The message from the commander from Spitzbergen, announcing his successful flight, came on equipment which used Pyrex Insulators.

\*Pyrex Insulators are always selected on such expeditions because of their dependability in conserving radio energy.

**CORNING GLASS WORKS**

INDUSTRIAL & EQUIPMENT DIVISION

Corning, N. Y.

\*U. S. PAT. OFF.

## STRAIGHT LINE SELECTIVITY

is only one of the big features of the new B-T

## COUNTERPHASE-EIGHT

Unless we're further off than we've ever been before the Counterphase-Eight is going to be one of the most talked-about sets of the year.

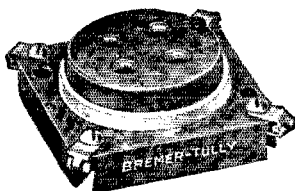

New Socket that acts on shock absorber principles rather than spring mountings.

**UX Socket 75c**

Watch the B-T Line

**BREMER-TULLY MFG. CO.** 532 So. Canal St. Chicago, Ill.

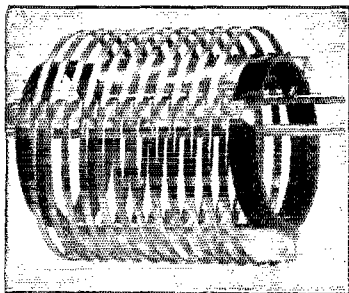

## TRANSMITTING INDUCTANCE FLATWISE WOUND ON GLASS

INDORSED BY LEADING AMATEURS AS THE IDEAL  
INDUCTANCE FOR C.W. TRANSMITTERS.

Type "L"—5" Dia—11 1/3 turns—for 40-80 and 150 Meter Bands.  
Type "S"—3" Dia—11 1/3 turns—for 20 Meters and lower.

Single Units with 3 Clips—Price \$5.50

Two Units (Pri. & Sec.) with Two Glass Coupling Rods—Price \$11.00

Priced Slightly Higher West of the Rockies

### RADIO ENGINEERING LABORATORIES

27 THAMES STREET, NEW YORK N. Y.

### *To Our Readers Who Are Not A. R. R. L. Members*

Wouldn't you like to become a member of the American Radio Relay League? We need you in this big organization of radio amateurs, the only amateur association that does things. From your reading of *QST* you have gained a knowledge of the nature of the League and what it does, and you have read its purposes as set forth on page 6 of every issue. We would like to have you become a full-fledged member and add your strength to ours in the things we are undertaking for Amateur Radio, and incidentally you will have the membership edition of *QST* delivered at your door each month. A convenient application form is printed below—clip it out and mail it today.

.....1926

American Radio Relay League,  
Hartford, Conn., U. S. A.

Being genuinely interested in Amateur Radio, I hereby apply for membership in the American Radio Relay League, and enclose \$2.50 (\$3 in foreign countries) in payment of one year's dues. This entitles me to receive *QST* for the same period. Please begin my subscription with the .....issue. Mail my Certificate of Membership and send *QST* to the following name and address.

.....  
.....  
.....

Station call, if any .....

Grade Operator's license, if any .....

Radio Clubs of which a member .....

Do you know a friend who is also interested in Amateur Radio, whose name you might give us so we may write him about the League? .....

..... Thanks!

# HAM-ADS

## NOTICE

Effective with this issue of QST the policy of the "Ham Ad" Department is altered to conform more nearly to what it was originally intended that this department should be. It will be conducted strictly as a service to the members of the American Radio Relay League, and advertisements will be accepted under the following conditions.

(1) "Ham Ad" advertising will be accepted only from members of the American Radio Relay League.

(2) The signature of the advertisement must be the name of the individual member or his officially assigned call.

(3) Only one advertisement from an individual can be accepted for any issue of QST, and the advertisement must not exceed 100 words.

(4) Advertising shall be of a nature of interest to radio amateurs or experimenters in their pursuance of the art.

(5) No display of any character will be accepted, nor can any typographical arrangement, such as all or part capital letters, be used which would tend to make one advertisement stand out from the others.

(6) The "Ham Ad" rate is 7c per word. Remittance for full amount must accompany copy.

(7) Closing date: the 25th of second month preceding publication date.

Here you are hams: an old familiar face with a new name. Existing QST regulations makes it necessary that we advertise under owner's name, but you will get same old, quick, efficient, intelligent service from the only ham store in the fifth district. No change in any way except name. We have the new Aero short wave plug in coils. Order yours today. Price is \$12.50 and worth it. You get three coils and base with primary mounted. Range is 15 to 180 meters. Write for our ham price list, it's free. Fort Worth Radio Supply Co. Operated by "Harris," 5RM, 104 East 10th St., Ft. Worth, Texas.

NEW generators, rated at 275 volts 120 watts will give 500 volts \$8. UC1831 variable 4000 volt condensers \$1.50. Bakelite 3 coil honeycomb, geared mountings \$1.50. Western Electric microphones \$1. VT2s \$4, VT1s \$3. Used generators, 30 volt direct current input, output 300 volts \$8. 500 cycle 200 watt \$10. 1/2 KW \$15. Send stamp for list. R. Wood, 38 Way Ave., Corona, New York.

WHERE'S the place to buy ham radio supplies? 9ALD of course. Years of experience and good service have made this the leading source of amateur transmitting and receiving equipment. There's a new hamalog, the original "Ham Catalog", waiting for you, listing all sorts of things you simply cannot get elsewhere, sent free on request. Discounts to dealers also—name your jobbers, using your letterhead. A few items of interest: Commercial Ammonium Phosphate, for chemical rectifiers, 40c per pound; Ward-Leonard grid leaks, 5000 ohm, for big sets, \$2.00, 4000 ohm 95c, 2500 ohm 80c. E. F. Johnson, 9ALD, Waseca, Minnesota.

THE life-blood of your set—plate power. Powerful, permanent, infinitely superior to dry cells, lead-acid Bs, B eliminators. Trouble-free, rugged, abuse proof, that's an Edison Steel-Alkaline Storage, B-Battery. Upset electrically welded pure nickel connectors insure absolute quiet. Lithium-Potassium solution (that's no lye). Complete, knock-down kits, parts, chargers. Glass tubes, shock-proof jars, peppy elements, pure nickel, anything you need. No. 12 solid copper enameled permanently perfect aerial wire 75c 100 ft. Make easy money with 1c battery service station charger. Details, full price list. Frank Murphy, Radio 8ML, 4837 Rockwood Road, Cleveland, Ohio.

OMNIGRAPHS—I want to buy 1000 used omnigraphs, quick. I. J. Ryan, Hannibal, Missouri, 9CNS.

RADIOMEN send for our radio catalog. 25% discount to hams. Radio Specialty Shop, 525 Park Ave., Kent, Ohio.

**SAY YOU SAW IT IN QST—IT IDENTIFIES YOU AND HELPS QST**

9AKD—Selling out. All parts in good condition. Write for list. Frank Libbe, 1014 N. Adams Street, South Bend, Indiana.

WANT one RCA microphone transformer UP414. R. L. MacAdam, Cobalt, Ontario.

MOTOR generator 350v 100w 110 drive \$25. R. Erickson, 1009 Pomeroy St., Kenosha, Wisc.

1000 VOLT—400 watt—Emerson motor generator. 110 volt 60 cycle. Just overhauled at factory, with extra armature, \$100. S. F. Northcott, 8DAT, 1204 N. Birney St., Bay City Michigan.

A real buy. One 1500 volt 600 watt Esco generator with Field rheostat. She's yours for 60 plunks. 9AUW.

BETTER Edison elements, welded connections 7c pair. Sample cell 10c. Paul Mills, Woodburn, Oregon.

LATHE work done and inductance of all kinds made to your specifications. Motors, generators and transformers rewound and repaired. James Milne, 9DXR, Brookings, South Dakota.

GREBE CR13 with one stage audio \$35. Trade for No. 2 omnigraph or Remler intermediate transformers. J. B. Crawford, 417 So. 13th Street, Omaha, Nebraska.

WANTED—Kenetron power unit. Model ET3620 RCA complete with tubes. Will give \$35. E. S. Benas, 4AE.

15 DIAL Omnigraph, perfect, with three dozen dials, etc. \$50 value for \$25, money order. A. B. Tripp, Avalon, Tacoma, Washington.

WANTED, 1 KW Packard transformer, prefer in metal container full mounted. 6BBH, Nielsen.

OMNIGRAPHS, vibroplexes, transmitting tubes and parts. Bought, sold. L. J. Ryan, (9CNS), Hannibal, Missouri.

WANTED: used UV206, 204 or 204A in good condition. Willard McCulla, 9CR, Waukegan, Illinois.

QST. New specialties for hams. A real ham insignia wid our own call. Wear 'em at conventions es ham fests. Hand made fm two-tone celluloid, set wid 50 imitation rubies, attractive es handsomely finished. Vy FB. Price \$2.00. Special design fer 1st dist. \$1.00 (no stones). Also flexible, transparent, 12 in. rule, clear as glass. FB fer laying out panel, charts, measuring around coils, etc. Ideal rule fer radio wrk. Price 25c. Goods sent on receipt of price. No stamps accepted. Descriptive circular on request. 1AJM, Box 373, Leominster, Mass.

HIGHGRADE phone cords, single, fine for microphones, loudspeakers, plug and jack systems, etc., 10c apiece, six for 50c. Humphray 2QS, Farragut Road, North Plainfield, N. J.

SELENIUM, two ounces for two dollars, money orders only. Leroy Schlichting, Davenport, Iowa.

FOR sale—Cutting and Washington 2KW type 12B transmitter. DeForest 20 watt type OT10. Lot of other transmitting receiving parts. Write for prices. All bargains. A. Damerow, Wabasso, Florida.

DODGE Radio Shortkut has helped many hams—will help you. Listen to reports from licensed users—9BNT, Creston, Iowa, says:—Thought was stung again, but tried to study and find out. At this time my speed was eight per After three evenings with Shortkut copied twenty per easily. 9CWM, Hickman, Kentucky, says: When got right slant on your plan raised my receiving speed from about fifteen to twenty-five per in three evenings. Our method kills hesitation and cultivates legible transmission. Information and reports from other hams on request. C. K. Dodge, Mamaroneck, N. Y.

SELL half list—transformers—meters, etc. Robert McCracken, Cuyahoga Falls, Ohio.

PURE aluminum and lead rectifier elements, holes drilled, brass screws and nuts, pair 1/16", 1" x 4", 13c, 1 x 6 15c, 1 1/2 x 6 17c, 1 1/2 x 6 19c. Sheet aluminum 1/16" \$1.00, 1/8" \$1.90. Lead \$1.00 square foot all prepaid. Silicon transformer steel cut to order .014". 10 lb. 25 cents, 5 lb. 30 cents, less than 5 lb. 25 cents per lb. 4 cubic inches to the lb. Postage extra. 1/2 cash with order—balance C.O.D. Edgewater wound copper ribbon .350" wide; 2 1/4" outside diameter 10c turn, 4 1/4" 13c turn, 5 1/4" 15c turn, 6 1/4" 17c turn, 7 1/4" 20c turn, prepaid. Geo. Schulz, Calumet, Michigan.

9DFM selling out. Everything goes regardless of cost. Drop card for list and prices. Detert, 1112 East Fifth, Duluth, Minnesota.

QSL cards. The 8BJT press will be in operation during August. Send in your order for the winter's supply of cards. Samples and prices cheerfully mailed. 8BJT, R. J. Mumaw, 701 Walnut Ave., Scottsdale, Pennsylvania.

3A CHOKES \$1.00. Generator filters \$2.00. Radio blinker signal set \$2.00. U. S. Signal Corps Service buzzer with key, headset and microphone \$4.00. S.L.F. 15 plate variable condensers 75c. Hammarline .0005 variable condensers \$1.50. Andrew Verbance, 1932 Wager Street, Columbus, Ohio.

WAVEMETERS. 10 to 100 meters, two coils, individually calibrated. Accuracy guaranteed within one percent. Excellent construction and handy size, with flash lamp. \$12.50. Short-wave Coils, set of five celluloid supported space-wound plug-in coils with mounting for that new receiver. 18 to 250 meters, \$4.00. We build real amateur equipment and carry the supplies you need. Send for list. Howard F. Mason, 7BU, 3335 32rd Ave. South, Seattle, Washington.

TRADE multiaudiphone mechanical amplifier for small dynamotor. 9CYC.

FOR sale—Harris visible typewriter at less than half-price. \$35. Transmitting and receiving apparatus. 9EJY, 9823 Rhodes Avenue, Chicago, Illinois.

SELL UV204 Radioron tube, Jewell 0-10 ammeter, omni-graph, etc. Thomas Wildman, Nichols, Iowa.

FOR sale—One Esco dynamotor, new, 6 volt primary, 500 volt secondary, ring oil. Fifty bucks. Also complete transmitter, 20 watts, C.W. and lone, 5 Jewell meters, complete R.C.A. parts, mounted on 18 x 24 panel. One hundred bucks. Might trade for 1000 or 1500 volt M.G. set. P. C. Lackey, 5AJ, Blanchard, Oklahoma.

1ZE at Mattapoisett has the following tubes for sale. 1UV204 new, used only few hours, \$50.00. 2UV204 tubes, old timers, but still good, \$20.00 each.

NEW Westinghouse TF 20 watt transmitters inductively couple 75-85-150-200 meters, 500v generator, 4 tubes, mike and key \$75. Ditto conductively couples less accessories \$40. 3 watt aeroplane transmitter 150-200 meters Meisner. Rotary switch controls, CW, ICW, voice and receive, 2 meters. With key, mike and tubes \$25.00. New UV203's \$20.00, W. E. 250 watter \$45.00. Order direct from ad; ¼ with order, balance C.O.D. N. L. Otis, 6BKZ-6DDJ.

WANTED 204A good condition. Cash or swap CR13 used two weeks. W. B. Michael, Caldwell, Ohio.

TWO dollars cash will take my vibrating key, a good one that does the work of a \$25 bug. Write today—8AKX—795 East 88th Street, Cleveland, Ohio.

TWO Western Electric 50 watters \$26 each. New UC1014 .002 mfd. 3000 volt condensers, \$1.80. 2BYJ.

FOR sale—new Westinghouse double commutator 750 v. 200 w. D.C. generators directly connected to 110 v. 50 cycle A.C. motor \$45.00. Field rheostat \$4.50 each extra. 25% with order, balance C.O.D. express inspection allowed. James J. Smat, 1734 Grand Ave., Chicago, Illinois.

AT Reduced Prices—Complete parts for the "New Home" and "Town and Country" receivers; also parts for short wave receivers. Bruno-Bradley coils. Benjamin new type condensers .00035 mfd. Amertran deluxe transformers. S.M. long wave frequency transformers. Samson frequency variable condensers. Jewell meters. B-T euphonic audio transformers. Low loss condensers. Acme chokes. R.E.L. transmitting inductances. Tobe transmitting condensers. Write us now for literature and information on our high-grade equipment. Sold to you direct by mail and everything shipped prepaid. M. B. Spinoza, 27 School St., Boston, Mass.

FOR real pure DC notes. General Electric 24/1500 volt .233 amperes dynamotors \$45. Slightly used, guaranteed perfect \$25.00. Ideal for battery supply. \$3.00 additional for belt drive. Equally as satisfactory. Crocker-Wheeler 450 watt \$45.00. GE 12/350 volt 143 ampere with filter condenser \$18.00. Westinghouse manufacture navy short-wave receivers 50-1000 meters, high grade wavemeters, navy keys with blinker light \$2.00. Cost government \$16.50 each. Cardwell .005 condensers \$2.00, 500 cycle generators. Henry Kienzle, 501 East 84th St., New York City.

SACRIFICE—Almost new Esco motor generator set, 110 AC to 550 DC, 200 watts. First money order for forty-five bucks takes the outfit. E. Feldman, 637 Tinton Ave., New York City.

GENERAL Electric tuner AR1400 \$12.00. CN213 navy tuner \$15.00. Short-wave receiver with two step amplifier and external jack made of General Radio parts 29 to 550 meters \$50.00. W. F. Worrell, Box 52, Bernice, Louisiana.

FOR sale—parts for small transmitter very cheap. Send for list. Arthur Dunlap, Bowserton, Ohio.

WANTED Large plate transformer (three, or four thousand volts anyway). Rodimon 1SZ A.R.R.L. Headquarters.

1CHQ press. West Hartford, Connecticut. Not just paper and ink but printing with a good international reputation.

## Q R A SECTION

50c straight, with copy in following address form only: CALL—NAME—ADDRESS.

1AHV—Richard P. Upham, 27 Eldredge St., Roslindale, Mass.

1CKY—Chas. A. Stone, 22 Comston Ave., Waterbury, Connecticut.

1QZ—Richard P. Upham, Bakers Island, Salem, Mass.

1VZ—C. M. Rice, Jr., 9 Bowdoin St., Worcester, Mass.

1ZA—C. E. Jeffrey, Jr., 725 Commonwealth Ave., Newton Center, Massachusetts.

2ATX—E. Dillmeier, Jr., 3408—114th St., Richmond Hill, Long Island, N. Y.

2AWL—J. Horner Kuper, 156 East 79th St., New York City.

2AWN—E. Dillmeier, Jr., 125 S. Clinton Ave., Bayshore, Long Island, N. Y.

2AYJ—Robert Poucel, Box 561, Oyster Bay, L.I. N.Y.

2MK—E. F. Reynolds, Central Valley, Orange County, New York.

2QR—John M. Avery, 131 South 29th St., Flushing, N. Y.

2QR—Richard Tinbergen, Box 78, Beachwood, New Jersey.

2SS—Frank Beers, 2144 Rockaway Parkway, Canarsie Shore, Brooklyn, N. Y.

3AJJ—Edwin F. Laker, Jr., 3908 Park Heights Ave., Baltimore, Maryland.

3OP—Edwin F. Laker, Jr., 3908 Park Heights Ave., Baltimore, Maryland.

4CZ—Clarence L. Durham, Box 550, Hendersonville, N. C.

5AFW—Louis Whitley Strieber, Yorktown, Texas.

5AQ—H. H. Green, 6119 Bryan Parkway, Dallas, Texas.

7AAW—Carl F. Wilson, Bonner, Montana.

8ADQ—Daniel H. Ammon, P. O. Box 37, Scranton, Pennsylvania.

8RX—City of the Straits Radio Club, Box 141, Halfway, Michigan.

8SV—J. L. McClung, 1221 Ninth Ave., Huntington, West Virginia.

8SX—John Ethier & James Norton, 3062 Garland Ave., Detroit, Michigan.

9ADG—K. Caird, 324 E. Center St., Park Ridge, Illinois.

9ARN—John S. Roelfs, Jr., Bartonville, Ill.

9AVM—Leslie E. Jaecke, Junction City, Kansas, R. 1.

9BHX—F. A. Hill, 10th & Grant St., Hinsdale, Illinois.

9BRH—J. Vernon Holmes, 2114 Grandview Blvd., Sioux City, Iowa.

9COX—Hance Van Beber, 1404 Broadway, Parsons, Kansas.

9DFM—George M. Deterb, 1112 East 5th St., Duluth, Minn.

c8BT—Fred Emery, 34 Kensington Ave., S., Hamilton, Ontario, Canada.

y1AM—Americo Mantegani Vazquez N° or Casilla Correo N° 37, Montevideo, Uruguay, Sud America.

y1CD—Ricardo A. Walder, Minas N° or Casilla Correo N° 37, Montevideo, Uruguay, Sud America.

yJCP-y1BR-y2AK—Juan C. Primavesi, Nueva York N° 1590 or Casilla Correo N° 37, Montevideo, Uruguay, Sud America.

The following stations belong to members of the A.R.R.L. Headquarters gang. Mail for them should be addressed care A.R.R.L., Hartford, Conn.

- |                     |                        |
|---------------------|------------------------|
| 1MK Headquarters    | 1ES A. A. Hebert       |
| 1AL H. P. Westman   | 1KP F. Cheyney Beekley |
| 1BAO R. S. Kruse    | 1OA R. S. Kruse        |
| 1BDI F. E. Handy    | 1SZ C. C. Rodimon      |
| 1BHW K. B. Warner   | 1XAQ R. S. Kruse       |
| 1DQ John M. Clayton |                        |

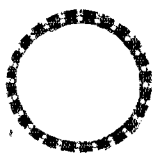

**"CAGE ANTENNA SPREADER"**  
DIAMETER 7 IN.  
Patented Sept. 8th, 1925

For erecting either a 4, 6 or 8 wire Cage Antenna System. Circular giving full details will be mailed upon request. Price \$4.50 per dozen; \$2.50 for a half dozen. No stamps. Immediate delivery. I pay the postage. Dealers investigate.

CHARLES F. JACOBS (RADIO 2EM)  
279 Park Place Brooklyn, N. Y.



We specialize in Amateur Transmitting and receiving equipment.

We carry a complete stock of all standard parts. Jewell meters, Acme chokes and transformers, Allen-Bradley, National, Pyrex, Thordarson, General Radio, etc.

Catalogue on request.

### NICHOLSON ELECTRIC CO.

1407 FIRST NORTH ST.,  
SYRACUSE, N. Y.

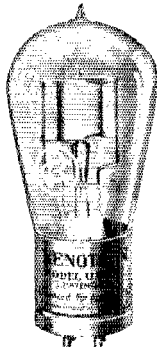

*(Everything for the Ham)*



## GENUINE

### Kenotron Rectifying Tubes

### Model UV-216

THESE Tubes are the GENUINE R.C.A. Kenotron Rectifying tubes. Filament voltage 7½ volts and will safely stand A.C. input of 750 volts. Four of these tubes will run a 50 watt.

These Rectifying tubes will pass plenty of current and voltage for your TRANSMITTER and also are very efficient for use in "B" ELIMINATORS.

STANDARD BASE. EVERY TUBE BRAND NEW AND PACKED IN ORIGINAL CARTONS.

**List price \$7.50 ea.—Extra Special \$1.85 ea.**

**AMERICAN SALES CO., 21 Warren Street, N. Y. C.**

## LOW REL LOSS

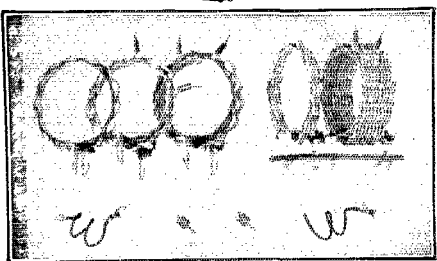

**PLUG-IN COILS**

SHORT WAVE AMATEUR STATIONS throughout the world are using REL LOW WAVE COILS. They have proven their superiority under actual operating conditions.

- 1—RUGGED MOISTUREPROOF COILS.  
Wound with Triple Cotton Paraffined Wire.
- 2—NO UNNECESSARY MATERIAL IN THE COIL'S FIELD.  
No metal Screws. No Circular Bakelite Frames. No Wire Binding Compound.
- 3—POSITIVE CONTACT PLUGS.  
The Only One Piece Spring Contact Plug on the Market Today. No Small Parts to Get Loose.
- 4—CAN BE USED IN ANY SHORT WAVE CIRCUIT.  
Two Primary Coils. Three Secondary Coils.
- 5—COVERS EVERY WAVELENGTH FROM 10 TO 110 METERS.
- 6—PRICED WITHIN THE REACH OF EVERY AMATEUR.

**\$4.50 COMPLETE**  
(At Your Dealer or Direct)

**RADIO ENGINEERING LABORATORIES**  
27 Thames Street, New York, N. Y.  
"The Low Loss Coil Pioneers"

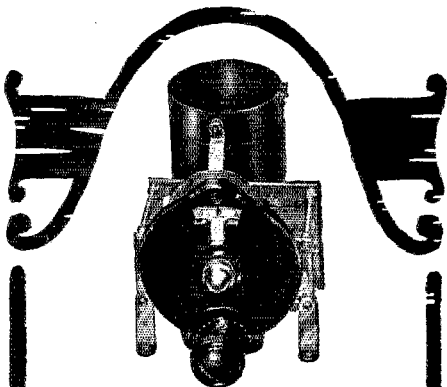

BD-1B includes the NATIONAL Equivolo (straight line frequency Condenser and the genuine BROWNING-DRAKE Inductance Coil with the new Type B Dial. Price \$10.25

### THE NEW NATIONAL Tuning Units

Comprising the genuine BROWNING-DRAKE SPACE WOUND TRANSFORMER and the NATIONAL Velvet Vernier Dials and Condensers

Are now in the hands of your dealer. Their beauty and efficiency will greatly surprise you. See them at your dealer's.

Send for Bulletin 105 R. B.

NATIONAL COMPANY, Inc.  
W. A. READY, President

110 Brookline St., Cambridge, Mass.

BD-2B includes the NATIONAL Equivolo (straight line frequency Condenser and the genuine BROWNING-DRAKE Transformer with the new Type B Dial. Price \$13.75

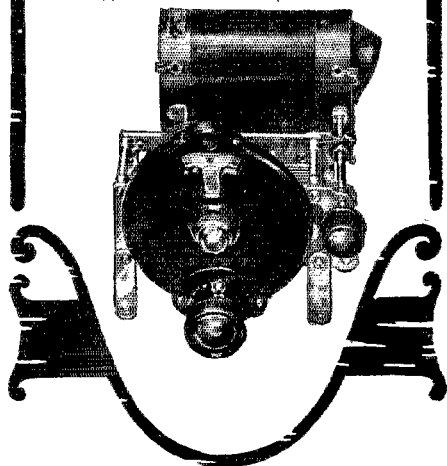

### YOU SAVE MONEY

By allowing us to quote our very low prices on TRANSMITTING and RECEIVING equipment, complete parts for the "New Home" Receiver. Also for short-wave receivers. Write today for catalogue.

**M. B. S. SALES CO.,** Dept. B.  
27 School St., BOSTON, MASS.

## FOR YOUR CONVENIENCE QST'S INDEX OF ADVERTISERS IN THIS ISSUE

Acme Apparatus Company .....	Page 63
Acme Wire Company .....	65
Advance Electric Company .....	86
Aero Products, Inc. ....	80
Aerovox Wireless Corp. ....	82
All American Radio Corporation .....	1
Amateur Radio Specialty Company .....	75
American Sales Company .....	93
American Transformer Company .....	86
A.R.R.L. Application Blank .....	90
Benjamin Electric Mfg. Company .....	74
Bremer-Tully Mfg. Company .....	89
Burgess Battery Company .....	4th Cover
Burton-Rogers Company .....	83
Cardwell, Allen D., Mfr. Co. ....	85
Carter Radio Company .....	72
Central Radio Laboratories .....	89
Corninz Glass Works .....	89
Cunningham, E. T., Inc. ....	End Cover
Crescent Radio Supply Company .....	80
Crosley Radio Corporation .....	72
Deutchmann Co., Tope .....	83
Dougan Electric Mfg. Company .....	76
Dubiler Condenser and Radio Corp. ....	73
Dudio Mfg. Corporation .....	36
Eagle Radio Co. ....	68
Eastern Radio Institute .....	83
East Side Y.M.C.A. ....	80
Electrad, Inc. ....	84
Electrical Engineers Equipment Co. ....	70
Electrical Specialty Company .....	73
Eikon Works .....	2
Ensell Radio Laboratory .....	88
French Battery Company .....	73
Prost, Inc., Herbert H. ....	87
General Instrument Company .....	78
General Radio Company .....	75
Grebe & Co., Inc., A. H. ....	4
Gross & Company, J. ....	84
Hughes Electric Company, Benl. ....	88
Hull & Company, S. W. ....	76
Jacobs, Charles F. ....	93
Jewell Electrical Instrument Company .....	81
Karas Electric Company .....	77
Magnavox Company .....	86
Marie Electric Company .....	70
M. B. S. Sales Company .....	94
National Carbon Company .....	85
National Company .....	94
Nicholson Electric Company .....	93
Patent Electric Company, Inc. ....	82
Pray & Company, F. R. ....	82
QST Premium Offer .....	3rd Cover
Radio Engineering Laboratories .....	90 & 93
Radio Surplus Corporation .....	86
Sangamo Electric Company .....	87
Scientific Radio Service .....	74
Silver Marshall, Inc. ....	87
Stromberg Carlson Telephone Mfg. Co. ....	69
Supertone Mfg. Company .....	82
Thordarson Electric Mfg. ....	81
Transmitting Equipment Co. ....	71
Utility Radio Co. ....	88
Vibroplex Co. ....	70
Ward-Leonard Electric Co. ....	71
Well's Curiosity Shop .....	80
Weston Electric Instrument Co. ....	78
Wireless Specialty Apparatus Co. ....	50
X-L Radio Laboratories .....	68
Taxley Manufacturing Co. ....	84
Zied, J. ....	80



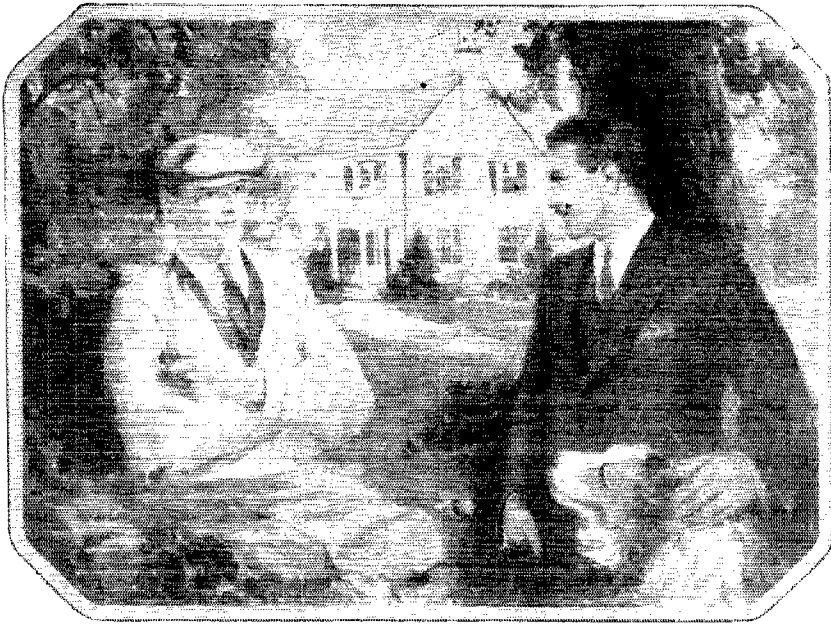

*"We give our sets about the same amount of use, but your 'B' batteries always last longer than mine. What's your secret?"*

"Why, there's really no deep, dark secret about it. It's simply knowing what are the right size batteries to buy for your set."

"Yes, but what do you mean by *right size*?"

"The right size depends on the number of tubes in your set. The more tubes you have, the bigger the 'B' battery you need to give you long, economical service. Just follow the rules laid down by Eveready."

These are the rules and the results:

*On all but single tube sets—Connect a "C" battery\*. The length of service given below is based on its use.*

*On 1 to 3 tubes—Use Eveready No. 772.*

\*NOTE: A "C" battery greatly increases the life of your "B" batteries and gives a quality of reception unobtainable without it. Radio sets may easily be changed by any competent radio service man to permit the use of a "C" battery.

*Listening in on the average of 2 hours daily, it will last a year or more.*

*On 4 or more tubes—Use the Heavy-Duty "B" Batteries, either No. 770 or the even longer-lived Eveready Layerbilt No. 486. Used on the average of 2 hours daily, these will last 8 months or longer.*

LEFT - No. 186, for 4, 5 or more tubes. \$5.50.

RIGHT - Eveready Dry Cell Radio "A" Battery, 1 1/2 volts.

**EVEREADY**  
Radio Batteries  
*-they last longer*

Send for booklet, "Choosing and Using the Right Radio Batteries." There is an Eveready dealer nearby.

Manufactured and guaranteed by  
**NATIONAL CARBON CO., INC.**

New York San Francisco  
Canadian National Carbon Co., Limited  
Toronto, Ontario

Tuesday night means Eveready Hour  
—8 P. M., Eastern Standard Time,  
through the following stations:

WEAF—New York WSAI—Cincinnati  
WJAR—Providence WTAM—Cleveland  
WEEI—Boston WWJ—Detroit  
WTAG—Worcester WGN—Chicago  
WFL—Philadelphia WOC—Davenport  
WGR—Buffalo WCCO { Minneapolis  
WCAE—Pittsburgh WLS { St. Paul  
KSD—St. Louis

# DUDLO

MAGNET WIRE AND WINDINGS

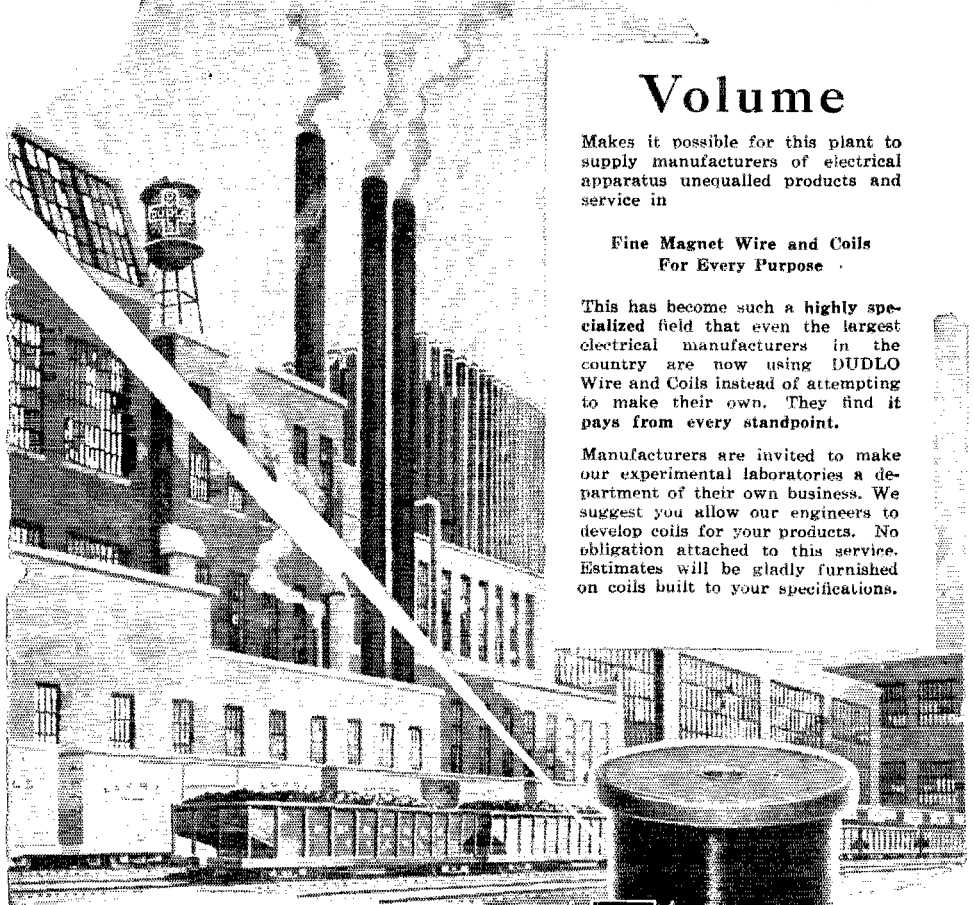

## Volume

Makes it possible for this plant to supply manufacturers of electrical apparatus unequalled products and service in

Fine Magnet Wire and Coils  
For Every Purpose

This has become such a highly specialized field that even the largest electrical manufacturers in the country are now using DUDLO Wire and Coils instead of attempting to make their own. They find it pays from every standpoint.

Manufacturers are invited to make our experimental laboratories a department of their own business. We suggest you allow our engineers to develop coils for your products. No obligation attached to this service. Estimates will be gladly furnished on coils built to your specifications.

This illustration pictures a small section of the great DUDLO plants at Fort Wayne, Indiana, the world's largest factories devoted exclusively to quality Coils and Magnet Wire.

*Eastern  
Office and Warehouse  
Newark, N. J.*

*Chicago Office  
160 N. La Salle St.  
Chicago, Ill.*

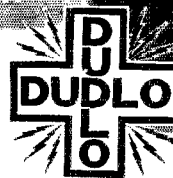

**DUDLO MANUFACTURING CORPORATION**

**FT. WAYNE, IND.**

# Here's And it won't cost you a cent !! Your Wavemeter!

Do you know your wavelength *exactly*? When a fellow says, "Listen for me on 39.6", do you know just where 39.6 is, on your tuner? Did you ever build a tuner and after it was finished find that its wavelength range was all wrong? Are you sure that you are operating your transmitter on a legal wave? For all those things, and many more, you need an accurate wavemeter.

If you are a member of the American Radio Relay League, we will send you without cost the wavemeter shown in the photograph, described on this page (inside rear cover) of the June issue of *QST*, in return for your helping the League by securing ten new member-subscribers.

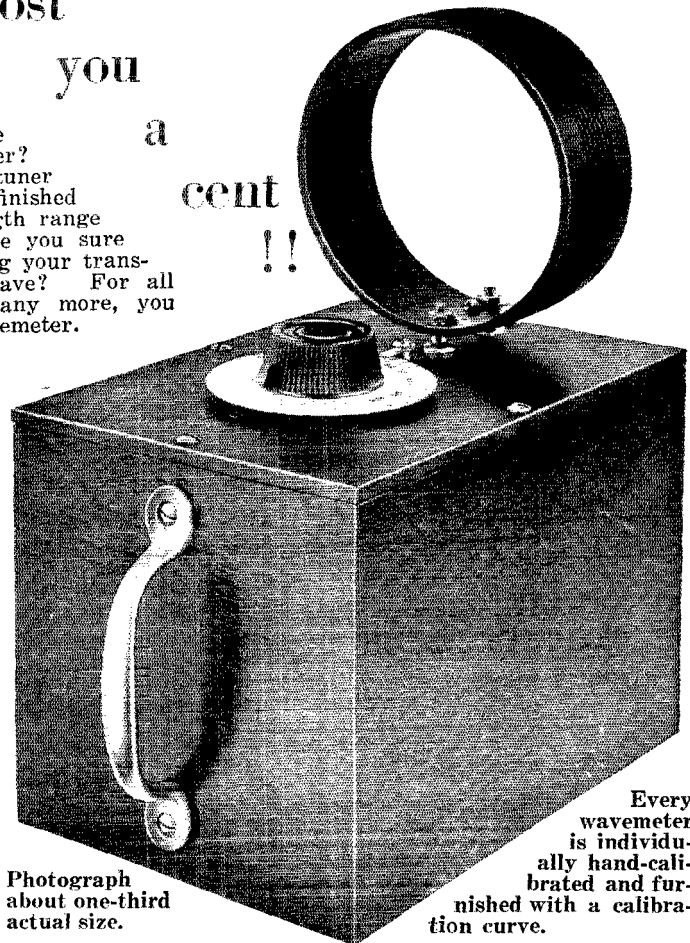

Photograph about one-third actual size.

Every wavemeter is individually hand-calibrated and furnished with a calibration curve.

Be sure to read this page of the last issue of *QST* for full details of the offer and for a complete description of the wavemeter.



Address  
*QST*, Circulation Department, 1711 Park St., Hartford, Conn.

# The TRANSMITTER and RECEIVER

*built by the BURGESS LABORATORIES and used by*

**HOWARD F. MASON**

*Chief Radio Operator for the Detroit Arctic Expeditions*

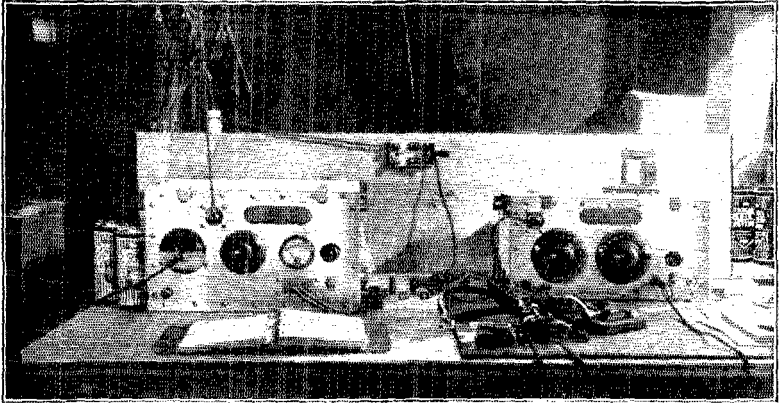

**V**IEW of portable transmitter and receiver built in the Burgess plant and now being used at Fairbanks and Point Barrow, Alaska. The transmitter has a wave length range of 24 to 80 meters, over which operator Robert Waskey at KFZH [Point Barrow] flashes all reports of the expedition. Both transmitter and receiver are operated by Burgess "A" and "B" dry batteries.

It was Waskey who scored a news beat which scooped the entire world when he saw and reported the first view of the dirigible Norge after it had passed over the top of the world and was seen at point Barrow May 12. A complete description of the radio equipment of this expedition is contained in the Burgess Engineering Circular No. 10, and you are invited to ask for a copy.



*First Landing at Point Barrow of the Alaskan, the Fokker Monoplane used to transport supplies from Fairbanks. The Alaskan was later wrecked in taking off.*

## BURGESS BATTERY COMPANY

GENERAL SALES OFFICE: CHICAGO

CANADIAN FACTORIES AND OFFICES: NIAGARA FALLS AND WINNIPEG

*In United States: Offices and Warehouses in Principal Cities*