

AUSTRALIA'S DYNAMIC ELECTRONICS MONTHLY!

Electronics Today

INTERNATIONAL

APRIL 1986

TWO HI-FI REVIEWS
AOR SCANNER REVIEWED

et

\$2.75*
NZ \$3.50

WIN A \$1827
SONY CAR HI-FI
PAGE 19 THIS ISSUE

CAR AUDIO: THE CAR SOUND REVOLUTION



GREAT PROJECTS TO BUILD:

BIT PATTERN DETECTOR — LOGIC TOOL
LOW COST MUSICIAN'S DIGITAL SAMPLER

VOYAGER URANUS RENDEZVOUS
INTERNATIONAL BROADCAST GUIDE

The best DMM in its class just got better.



The Fluke 80TK. One innovation leads to another.

First there was the 70 Series, which set a new standard for low-cost, high-performance, Fluke-quality multimeters.

And now, another first. The Fluke 80TK K-type Thermocouple Converter. A temperature measurement device that adds instant temperature measurement capabilities to the 70 Series DMMs.

Or any DMM, for that matter.

Feature for feature, the versatile 80TK is the most affordable unit of its kind. For quick comparison readings, it can measure °C or °F at the flick of a switch. It includes a built-in battery test. And the availability of 3 Fluke probes give you the flexibility to measure any

form of temperature, from freezer to furnace, with just one base unit.

No other thermocouple converter we know of offers DMM users so much for so little.

So even if you don't own a Fluke 70 Series multimeter, the 80TK will help the DMM you're now using measure up when things get hot. Or cold.

FROM THE WORLD LEADER
IN DIGITAL MULTIMETERS.

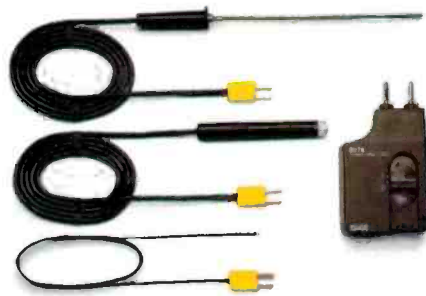

Surface, immersion and general-purpose probes with "mini" thermocouple connectors are available for the Fluke 80TK.

80TK SPECIFICATIONS

Temperature Measurement Range
-50 to 1000°C
-58 to 1832 °F
Battery Life: 1600 Hours (9V)

ELMEASCO Instruments Pty. Ltd.

N.S.W. 15 McDonald St, Mortlake. Tel: (02) 736 2888
VIC. 12 Maroondah Hwy, Ringwood. Tel: (03) 879 2322
QLD. 243 Milton Rd, Milton. Tel: (07) 369 8688
S.A. 241 Churchill Rd, Prospect. Tel: (08) 344 9000
W.A. 46-48 Kings Pk Rd, West Perth. Tel: (09) 481 1500

Talk to your local distributor about Fluke

• A.C.T. Actlec Pty Ltd (062) 80 6576 • George Brown 80 4355 • N.S.W. Ames Agency 699 4524 • George Brown (02) 519 5855 Newcastle 69 6399 • Bryan Catt Industries 526 2222 • Collier Tools 763 1888 • D.G.E. Systems (049) 69 1625 • Davred Electronics 267 1385 • W.F. Dixon (049) 61 5628 • Macelec (042) 29 1455 Ebson 707 2111 • Selectro Parts 708 3244 • Geoff Woods 810 6845 • N. TERRITORY Thew & McCann (089) 84 4999
• QUEENSLAND L.E. Boughen 369 1277 • Colourvlew Wholesale 275 3188 • Fred Hoe & Sons 277 4311 • Nortek (077) 79 8600 • St Lucia Electronics 52 7466 • Selectro Parts (Qld) 394 2422 • S. AUSTRALIA Protronics 212 3111 • Trio Electric 212 6235 • Redarc Electronics 278 7488 • A.W.M. Wholesale • TASMANIA George Harvey (003) 31 6533, (002) 34 2233 • VICTORIA A.W.M. Electrical Wholesale • Radio Parts 329 7888 • G.B. Telespares 328 3371 • Browntronics 419 3986 • R.K.B. Agency 82 7704 • A.J. Ferguson 347 6688 • SIRS Sales (052) 78 1251 • Mektronics 690 4593 • W. AUSTRALIA Atkins Carlisle 321 0101 • Dobbie Instruments 276 8888 • Cairns Instrument Services 325 3144 • Willis Trading 470 1118

Electronics Today

FEATURES

Car audio	12
No want for high fidelity	
Showtime in Las Vegas	20
The Winter CES brings out the best acts	
BMAC: the new TV format	38
The technical implications	
Starting electronics	69
When the chips are down — or when it comes down to chips!	
1985 Index and collected errata	77
1985 features, projects, reviews, columns, errata	
Shortwave listening	85
Schedule of SW programmes received in Australasia	
Voyager at Uranus	108
Images of another world	

PROJECTS

ETI-1402: Digital sampler	51
ETI-172: Bit pattern detector	58

REVIEWS

Classy car CD player	28
Yamaha's YCD-1000 is something to be proud of	
Sound move for cars	33
Quality maintained with Sony's XR-A640 AM/FM stereo radio/cassette	
Understudy	46
A top performance by the XP640 EPROM programmer and EM520 emulator	
Home computer	82
The Amstrad 6128 should have wide appeal	
Smallest is best	92
The highly commended AOR AR-2002	

OFFERS

Advertisers' index	100
ETI mail order books	97,98,101
ETI-School projects competition	102
ETI-Sony competition	19
Subscriptions offer	106

DEPARTMENTS

News Digest	6	Ideas for Experimenters	67
Sight and Sound News	26	Shoparound	84
New Equipment	43	Minimart	100
Idea of the Month	66	Dregs	114

COVER: Designed by Vicki Jones, sports car photograph supplied by Colorific, photographer Seth Joel.

EDITOR
David Kelly B.Com.

ASSISTANT EDITOR
Jon Fairall B.A.

EDITORIAL STAFF
Mary Rennie B.A.
S. K. Hui B.Sc. (Hons), M.Eng.Sc., MIEEE
Neale Hancock B.E.

DRAUGHTING
David Burrows

ART DIRECTOR
Vicki Jones

ART STAFF
Gary Gray
Ray Eirth

ADVERTISING MANAGER
Peter Hayes B.Sc.

ADVERTISING PRODUCTION
Wayne Hanley

READER SERVICES
Pam Todd

ACOUSTICAL CONSULTANTS
Louis Challis and Associates

PUBLISHER
Michael Hannan

HEAD OFFICE
140 Joynton Avenue, (PO Box 227)
Waterloo, NSW 2017.
Phone: (02) 663-9999 Sydney.
Telex: 74488, FEDPUB.
Federal Facsimile: 662-1007.

ADVERTISING
New South Wales
Peter Hayes, Mark Lewis (02) 663-9999

Victoria and Tasmania
Leigh Crosbie, Virginia Salmon (03) 662-1222

South Australia and Northern Territory
Dane Hanson (08) 212-1212

Queensland
Warren Tapner (07) 854-1119

New Zealand
Chris Horsley 39-6096 (Auckland)

OFFICES
New South Wales: The Federal Publishing Company, 140 Joynton Avenue, Waterloo, NSW 2017.

Victoria and Tasmania: The Federal Publishing Company, 23rd Floor, 150 Lonsdale Street, Melbourne, Vic. 3000. Phone: (03) 662-1222. Telex: 34340, FEDPUB.

South Australia and Northern Territory: John Fairfax & Sons, 101-105 Waymouth Street, Adelaide, 5000. Phone (08) 212-1212. Telex: 82930.

Queensland: The Federal Publishing Company, 26 Chermiside Street, Newstead, Qld. 4006. Phone: (07) 854-1119.

Western Australia: Tony Allen & Associates, 7 Fore St, Perth, WA 6000. Phone: (09) 328-9833.

New Zealand: 4A Symonds Court, Symonds Street, Auckland. Telex: NZ60753, TEXTURE. Phone: 39-6096. Auckland.

ELECTRONICS TODAY INTERNATIONAL is published monthly by the Electronics Division of the Federal Publishing Company Pty Limited, 140 Joynton Avenue, Waterloo, NSW 2017 under licence from Double Bay Newspapers Pty Limited, General Newspapers Pty Limited and Suburban Publications Pty Limited. Typeset and printed by ESN-The Litho Centre, Sydney. Distributed by Gordon and Gotch Limited, Sydney. *Maximum and recommended Australian retail price only. Registered by Australia Post, Publication No NBP0407. ISSN No 0013-5216.

COPYRIGHT © 1985, Double Bay Newspapers Pty Limited, General Newspapers Pty Limited and Suburban Publications Pty Limited (trading as "Eastern Suburbs Newspapers").



High-tech Audio Hits the Highway

Everything that opens and shuts – and the best sound on wheels.

The Aiwa CT-X500 has features that the others don't have. And possibly the most revolutionary of them all is the Stereo Total Operation Panel (S.T.O.P.). It removes completely for remote control operation. When not in use, the entire panel snaps up to blend your car audio system into your car's dash with a neat, clean appearance that is completely undetectable from outside the car. Which not only looks good, but helps prevent dust – and theft.

Features – features – features:

- Removable remote control system
- Theft-preventing "Stereo Total Operation Panel"
- Quartz synthesis tuning

- 12 station pre-set memory (6xAM, 6xFM)
- Auto Reverse tape playback
- Electronic volume control
- "Dynamic Super Loudness" for superb bass reproduction
- Dolby B/C noise reduction
- Metal tape capability
- Digital Quartz Clock
- Active Tuning Reception Control (ATRC)
- Feather-touch full IC logic control
- Maximum power output of 16 watts (8w/ch)
- Electronic volume control
- Soft loading and eject system
- Music sensor
- Supplied installation sleeve with integrated push-in connector

Ask your dealer to show you the AIWA CT-X500. Then, touch and listen. You'll be very, very impressed.

AIWA

If you don't believe your eyes, believe your ears.



SERVICES

TECHNICAL INQUIRIES: Technical inquiries by mail must be accompanied by a stamped self-addressed envelope. There is no charge, but we reserve the right to publish the inquiry and the reply in *Electronics Today* or any of its associated publications. We can only answer queries relating to projects and articles as published. We cannot advise on modifications, other than errata or addenda. Difficult questions may take some time to answer.

GENERAL INQUIRIES: For all inquiries about back issues, subscriptions, photocopies of articles, artwork or submitting articles, call (02) 663-9999 or write to: ETI Reader Services, 140 Joynton Avenue (PO Box 227), Waterloo, NSW 2017.

CONTRIBUTIONS: Submissions must be accompanied by a stamped, self-addressed envelope. The publisher accepts no responsibility for unsolicited material.

COPYRIGHT: The contents of *Electronics Today International* and associated publications is fully protected by the Commonwealth Copyright Act (1968). Copyright extends to all written material, photographs, drawings, circuit diagrams and printed-circuit boards. Although any form of reproduction is a breach of copyright, we are not concerned about individuals constructing projects for their own private use, nor by bands (for example) constructing one or more items for use in connection with their performances. Commercial organisations should note that no project or part project described in *Electronics Today International* or associated publications may be offered for sale, or sold in substantially or fully assembled form, unless a licence has been specifically obtained so to do from the publisher, The Federal Publishing Company, or from the copyright holders.

LIABILITY: Comments and test results on equipment reviewed refer to the particular item submitted for review and may not necessarily pertain to other units of the same make or model number. Whilst every effort has been made to ensure that all constructional projects referred to in this edition will operate as indicated efficiently and properly and that all necessary components to manufacture the same will be available, no responsibility is accepted in respect of the failure for any reason at all of the project to operate effectively or at all whether due to any fault in design or otherwise and no responsibility is accepted for the failure to obtain any component parts in respect of any such project. Further, no responsibility is accepted in respect of any injury or damage caused by any fault in the design of any such project as aforesaid.

NEVER ONE WHO LIKES to see a great resource go to waste I'd like to put in my five cents worth about Australia's national television broadcaster, the ABC.

No, it is not the part of the day taken up by programming that I want to comment on, not this time at least, but the greater part of the day when ABC television stations around the country do nothing but circulate electrons.

In the UK, a country where the problems of travelling to an educational institution pale into insignificance, they have a system called the open university. The open university presents most of its lectures during the otherwise unused hours of broadcast television.

With a very high science and maths content the UK service has shown itself a very effective medium for theory based subjects. Even those courses that cannot depend solely on broadcast lectures can combine local area tutorials and a few weeks a year of residential school with the broadcasts.

What a great idea. A country, the economic future of which will depend on the knowledge and skill of its workforce, will be able to provide a high quality education to people in any part of the it.

Economically it makes a lot of sense to have an education system which is accessible to people who are already in work, but who want to upgrade their skills. After all, it is unskilled workers who run the greatest chance of unemployment and it is the manufacturers that employ them in greatest numbers that have the most difficulty in competing with imports.

As a national open university, the programme content and courses could be organised by the Australian National University in Canberra. Individual courses could be sponsored by other universities. Even if the system cost \$10 or \$20 million to run it would use up only a very small part of the Federal Government's total university budget.

The ABC could have other educational uses as well. Even the state education departments could use off-peak ABC television time to distribute video material to schools. Most schools have video cassette recorders that can record programmes in the wee small hours of the morning and play them back to students during class hours.

So next time you turn on the ABC and see the test pattern or black and white bars just think that that valuable spectrum and transmission equipment could actually have been put to some use.

David Kelly
Editor

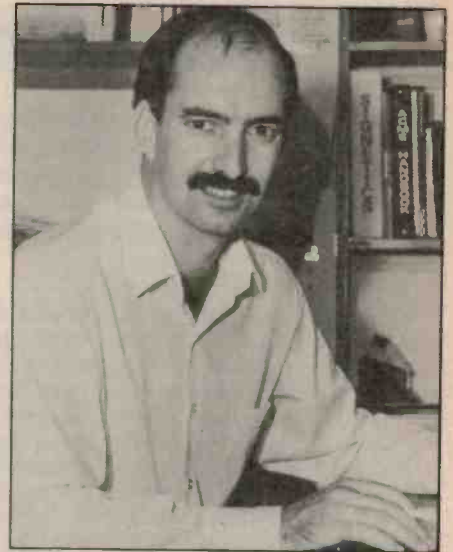

SUBSCRIBERS SHOULD NOTE that they can receive a free ETI publication with this issue. Because of packaging problems it has not been included. Subscribers who want the publication should write to ETI April Offer, PO Box 227, Waterloo NSW 2017.

ETI-684 INTELLIGENT MODEM

Next month we steam into the hardware of our all-encompassing modem with construction details. The finished product should auto answer, auto dial, has auto bauding, 1200/75, 600/75, 300/300 baud, with Hayes command compatibility and cassette control.

STARTING ELECTRONICS

This series has long got beyond mere basics. In the May issue of ETI we'll examine the logic of digital, make some comparisons with analogue and, most importantly, look at the applications of digital electronics. This means looking at things like gates, flip-flops, counters and other ICs. So if you're a bit rusty on the theory — or completely hazy — this is recommended reading.

NEXT MONTH

CHOOSING A CRO

This invaluable guide lists what's available on the market as well as suppliers. Once your CRO is chosen we help you get the best out of it with thorough details of usage.

REVIEWS

Dali makes great claims for its new Dali 8 monitor speakers. The speakers incorporate some innovations such as using two 8-inch woofers instead of a single 12-inch woofer! Louis Challis tests Dali's claims. He also puts NEC's first venture into CD players through its paces.

Flight simulators

News about great Aussie inventions going overseas are a dime a dozen, of course, regularly bemoaned in this journal and lots of others with a commitment to Australian creativity. So it's something of a surprise to hear about an Australian businessman snaffling up an opportunity that foreign businessmen had passed up.

The device in question is a low cost flight simulator, developed by Dr Dave Allerton and colleagues at the University of Southampton in England. Allerton won a contest held by the Royal Aeronautical Society for the design of a flight simulator costing less than \$6000. His prize was an opportunity to tout his invention across the UK, looking for someone to turn it into a commercial product. In the event the silence was frightening, and Allerton returned to Southampton frustrated and no doubt somewhat chastened. "I could have sold the finished product a hundred times over," he says, "but finding someone to put money up front was impossible."

Meanwhile, in the sleepy NSW Hunter Valley town of Cessnock Jim Sparkes, who

heads up the Civil Air Transport Academy, was looking for ways, as businessmen often do, to cut costs. Need and inspiration came together and resulted in something that looks rather like an overgrown mechano set. There are two video screens, one above the other, one displaying a horizon line with some mountains behind it, the other all the instruments. When I saw it, metal bashers were scratching their heads over how to mount the joystick and foot pedals, where to put the seat, and how to make it all look more realistic. Not terribly inspiring perhaps, especially if you've seen how good simulators can be. But the reason for all the optimism in the place springs from the little black box off to one side.

Inside it a 68008 processor is busy crunching numbers, re-

creating a frame 25 times a second. Every time it goes through the cycle the machine first considers the existing position and attitude of the aircraft, then looks at the position of all the flight controls. Armed with this information it resolves a matrix of equations that contain the complete flight equations of the aircraft, specifying a new position and attitude in space.

From this, calculations for every pixel on the screen (each 8 bits) are spat out at a phenomenal rate. According to Allerton, the use of floating point arithmetic, and the fact that the 68008 multiplication and division algorithm is so good means that it works about 20 times faster than normal.

It uses a frame store and two interchangeable banks of memory, rather like the Apple computers used to. As you write to one bank, the other one is being read out to the screen. At the end of each field the screens are interchanged. The requirements for speed and circuitry are minimised somewhat by using the standard interlace pattern of the

PAL system to provide two different fields, each with 312 lines to build up a complete frame.

As well as the graphics, the machine also has 24 A/D channels for driving sound effects generators and navigation signals. The sound effects are used for engine noise and wind roar.

Development proceeds apace. At Southampton they're designing a computer graphics interface, consisting of 30 68008 processors. This will give the simulator a more detailed landscape out of the window. Meanwhile, the University of Newcastle, which has a long standing interest in both computer graphics and computer modelling of aeroplanes, is also getting in on the act. According to Dr Tony Cantoni, of the electrical engineering department, they're more than interested in developing the graphics ability of the simulator further.

How soon to a fully fledged prototype? Not for a while yet apparently, but already the expressions of interest are starting to come in. It's looking good up in Cessnock.

COMPANY NEWS

Michael Bell has recently been appointed to the position of general manager — Computer Products with the Dick Smith Electronics Group. He was formerly divisional manager of Monitrol Australia.

Ian McKenzie, group general manager of Philips' professional products and systems division, has been appointed the new president of the Australian Electronics Industry Association (AEIA). He replaces Bruce Goddard, managing director of Plessey Pacific, who has retired from the AEIA presidency after two years in office. G. Page-Hanify, managing director of STC has been appointed Vice-President of AEIA.

Rohde & Schwarz has appointed Eric Lawson to the newly created position of product manager. Mr Lawson comes to Rohde & Schwarz with considerable experience in electronic instruments having previously held a position as senior technical officer with Telecom Australia. More recently Mr Lawson was product manager in the Instrument Division of Warburton Franki Melbourne office.

Syntec International Pty Ltd has moved to 60 Gibbs St, Chatswood, NSW 2067. (02)406-4700.

Syntec distributes a range of Revox hi-fi equipment. The new premises includes a small recording studio for practical demonstration of its high quality studio recording equipment.

A word from DOC

The Australian Frequency Allocation table in the Data Section of January's ETI (p61) incorrectly indicates that Amateur usage is permitted in the 27 MHz Marine Band, specifically 27M860, 27M900, 27M910, 27M940 and 27M960. In fact, as we have been advised by the Department of Communications, the bands are not allocated for Amateurs (Ham operators), but for non-commercial organisations such as amateur fishing, boating and yachting clubs, surf clubs, and the Coast Guard for safety and movement messages and club activities.

CRO WINNER

The lucky entrant in the ETI/Elmeasco Instruments CRO competition, run in last December's ETI, is Don Chesher of Fraser, ACT. Don is a bit of a hobbyist — In fact, he's enrolled in a TV servicing course at the local TAFE just for fun. We're happy the \$1576 worth of Aaron BS-625 CRO from Elmeasco will get good use!

Don's correct answers were:

- How many kilohertz are there in 10 gigahertz?
10,000,000 ✓
- A 1 kHz, 2.12 Vrms sine wave signal is measured on a CRO with X10 probe. If the vertical sensitivity is set at 50 mV/div, how many divisions would the waveform take up peak to peak?
12 ✓
- If you have an infinite number of 100Ω resistors connected in parallel, what is the total resistance?
Zero ohms ✓

20MHz OSCILLOSCOPES

With Component Tester

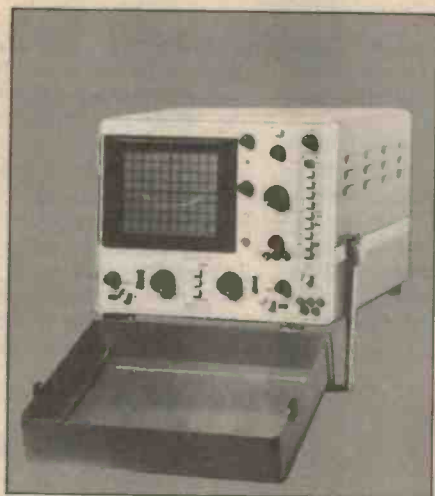

The APLAB oscilloscope Model 3132 is a dual trace 20 MHz scope with minimum sensitivity of 2mV/div and minimum sweep speed of 0.5 us/div.

Triggering modes include TV line or TV frame sync.

Other features include:

- Built in triple DC source
+5V +12V \pm 12V
- Dual component tester
comparator.



LABORATORY POWER SUPPLIES

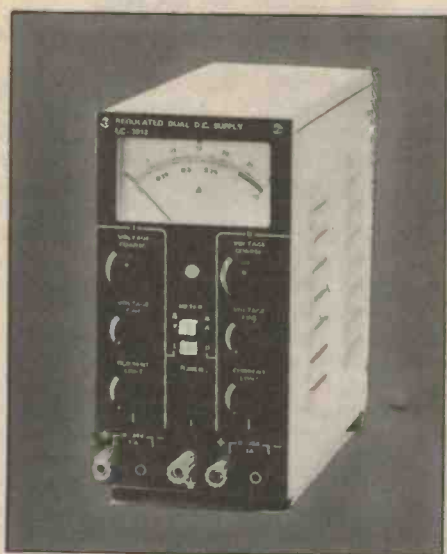

APLAB offer a complete range of regulated DC bench/rack power supplies combining high precision and regulation capabilities with continuously adjustable outputs.

Designed with single, dual and multiple outputs, these power supplies can be used in either constant voltage or constant current mode of operation.

Standard models include:

SINGLE OUTPUT

OUTPUT: Output
VOLTAGE: Current
0-30V 0-1A to 30A
0-70V 0-2A to 10A

DUAL OUTPUT

0-30V 0-1A to 2A

MULTIPLE OUTPUT

0-30V 0-2A to 5A



SCIENTIFIC DEVICES AUSTRALIA PTY. LTD.

VIC. 2 JACKS RD., SOUTH OAKLEIGH. 3167

PHONE: (03) 579 3622 TELEX: AA32742

NSW: 559A WILLOUGHBY RD., WILLOUGHBY 2068

PHONE: (02) 95 2064 TELEX: AA22978

S.A. 31 HALSEY RD., ELIZABETH EAST. 5112

PHONE: (08) 255 6575 TELEX: AA88125

Advances in bipolar

Chip designers at Texas Instruments have developed a technique for manufacturing bipolar chips that presents more competition to CMOS. The Impact X process improves packing density ratios, speed, reliability and decreases power consumption significantly.

The new technology represents a continuation in the Impact techniques TI has already

used. The p-type substrate and epitaxial layers are grown in the usual manner. However, Impact X uses a trench isolation process in preference to the common oxide isolation process; this entails a groove 1.5 to 2 μm wide x 8 μm deep, cut through the epitaxial layer into the substrate. The trench walls are coated in oxide and a channel stopper is used to prevent inversion and

leakage at this interface. Circuit elements are formed in a field-protective oxide deposited atop the trench.

The same photomasking techniques are used as in the previous Impact methods, but the new technology requires the creation of a shallow base, deep collector and shallow polysilicon emitter. The metallisation process consists of the application

of platinum silicide and titanium tungsten to prevent the aluminium element diffusing into the silicon and destroying the junction. Emitter and collector contacts are then formed and a surface of passivating substance is added for protection.

The main advantage of the Impact X technology lies in the trench isolation technique which reduces the pitch distance between individual transistor emitters to about 6 or 7 μm . This allows much closer packing density which consequently reduces lead interconnection between devices, and results in faster circuits. Shallower base and emitter junctions allow higher operating frequency and quicker switching speed.

The polysilicon emitter means a higher gain which reduces the amount of power the IC needs, thus reducing heat dissipation.

The trench isolation method also eliminates masking steps which should shorten and increase production runs thus reducing price.

The reduced size coupled with the bipolar's greater current driving capabilities makes the bipolar process a viable alternative to CMOS.

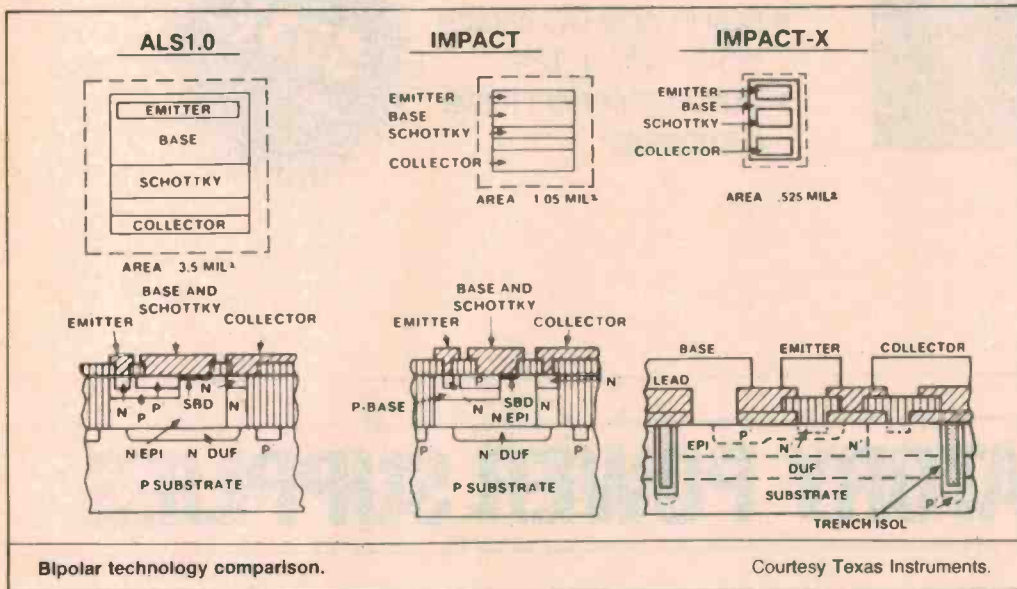

Bipolar technology comparison.

Courtesy Texas Instruments.

French lessons

Telecom recently celebrated the registration of its 10,000th Viatel user. A noteworthy event, but for most people, Viatel is still too poorly endowed with services to warrant the Telecom subscription and use charges, and too few people have subscribed to Viatel to attract companies to become service providers. ETI, for example, sees some viability in listing its cumulative index on Viatel, but not until enough people can access it.

But Telecom does stand to make a good deal of money out of Viatel. Subscription charges are presently \$2.50 per month for domestic users of Viatel, and \$12.50 per month for businesses. Connection charge is 16 cents, then there is a time charge of 8

cents per minute during business hours and 5 cents per minute at other times. Charges for service providers are variable.

To tap into this so far rather restricted venture, Telecom might take a lesson from its French equivalent, the Direction Générale des Télécommunications. As with the US, West Germany and Japan, the limiting factor in the success of videotex systems in France has been the prohibitive cost of terminals. The DGT has countered this by giving cheap terminals away to telephone subscribers and thus encouraging interest in its videotex system, Minitel. Minitel has thus been kept simple, sans colour graphics or access to large data bases.

So far the DGT has spent an

estimated \$US666m on switching equipment and \$US1.1m on terminals. However, it expects to recoup this investment in the space of four years in increased telephone traffic. These predictions seem to be actualising. Minitel has proved a great success. The system handles 15 million calls per month, 50 per cent of which are to the electronic telephone directory, 20 per cent are for business purposes, with the remaining 30 per cent to more frivolous enterprises. These successful enterprises include news, data bases and what might facetiously be called a 'French Letter' service, which allows people to chat amorously for as long as someone will put up with them. Apparently this aspect has proved so fearfully popular that some companies have banned the Minitel number

from their phone systems!

According to a recent US report on the service, Minitel has boosted telephone usage in France by 10 per cent. But an important part of Minitel's success has to be attributed to the DGT's policy of passing on two thirds of the Minitel users' fee to the service provider.

While Australia has a high proportion of computer 'terminal' owners (one person in less than 12) there is still the need for a modem to link the computer to the telephone line and on to the Viatel service. Telecom is apparently considering listing its directory on Viatel as the French have done; perhaps it could also follow the French example and distribute modems and terminals to its subscribers and break out of the unprofitable Viatel circle.

Fuji-Toughest Tapes Under the Sun



A desert is the last place you'd want the car to break down. But does HE look worried? Though the heat is on, this cool customer's Fuji GT car stereo cassettes keep the music flowing clear and clean.

GT's outer casing as well as the tape itself can withstand temperatures up to 110°C (230°F)! while offering unsurpassed sound performance over rough roads. A special dual-spring pressure pad –

similar to a car's independent suspension – maintains tape pressure and close contact with the heads when the cassette deck is vibrating.

GTs sound hot on the highway too, with high-note clarity that overcomes sound-deadened car interiors. And clever concave "A" and convex "B" side markings and different left/right feel allow quick side selection by touch – without taking your eyes off the road.

On or off-road, hear for yourself why Fuji GTs are the toughest tapes under the sun.



DISTRIBUTED IN AUSTRALIA BY **HANIMEX**





YAMAHA
CAR AUDIO

Now, Yamaha for your car. But

Yamaha. Makers of fine

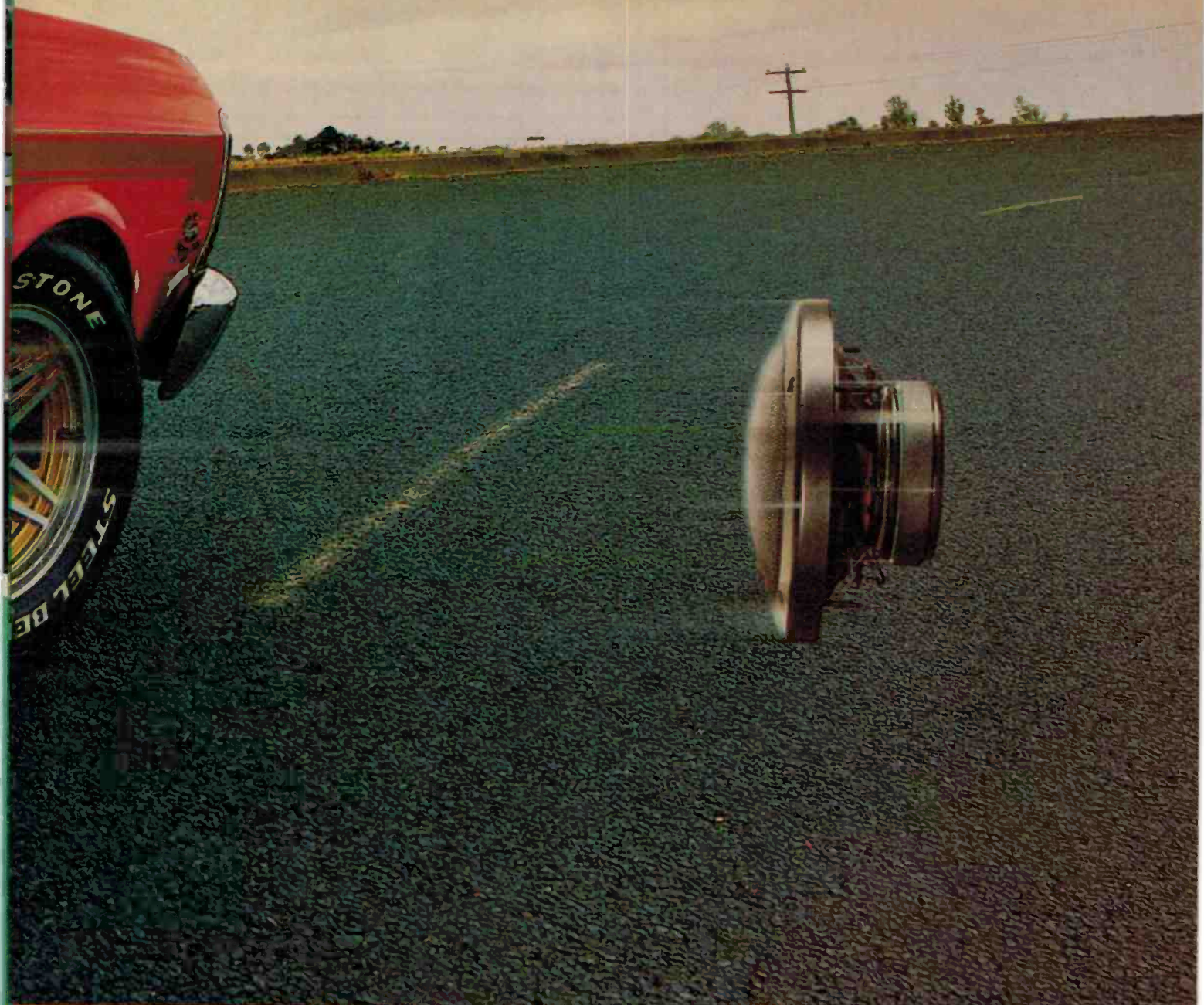

do go easy on the volume controls.

musical products since 1887.



Inside a modern cassette deck: the Kenwood KRC-929D/929.

1. dc servo motor
2. High precision tape transport
3. Preamp section
4. Double-sided glass-epoxy circuit board
5. Independent bass and treble controls
6. Quartz PLL synthesiser LSI (reverse side)
7. Double-sided flexible pcb
8. Static electricity prevention-type switch contact element
9. High precision mould-type switch block
10. Full logic mechanism control section
11. Auto-loading and key-off eject mechanism
12. Long life new ceramic head
13. MW/LW front end
14. FM front end
15. Dolby B/C NR section
16. FM IF
17. PNBS
18. FM MPX
19. ANRC
20. Low noise tape head amp
21. SDK section
22. High rigidity 1mm thick chassis
23. Key matrix section

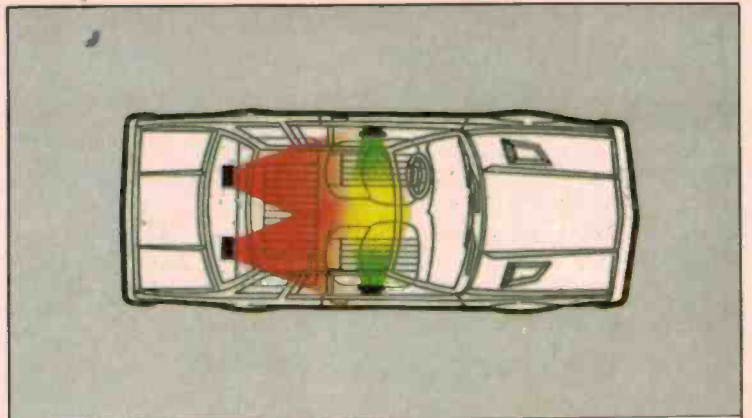

Standard speaker distribution: red = bass; green = treble.

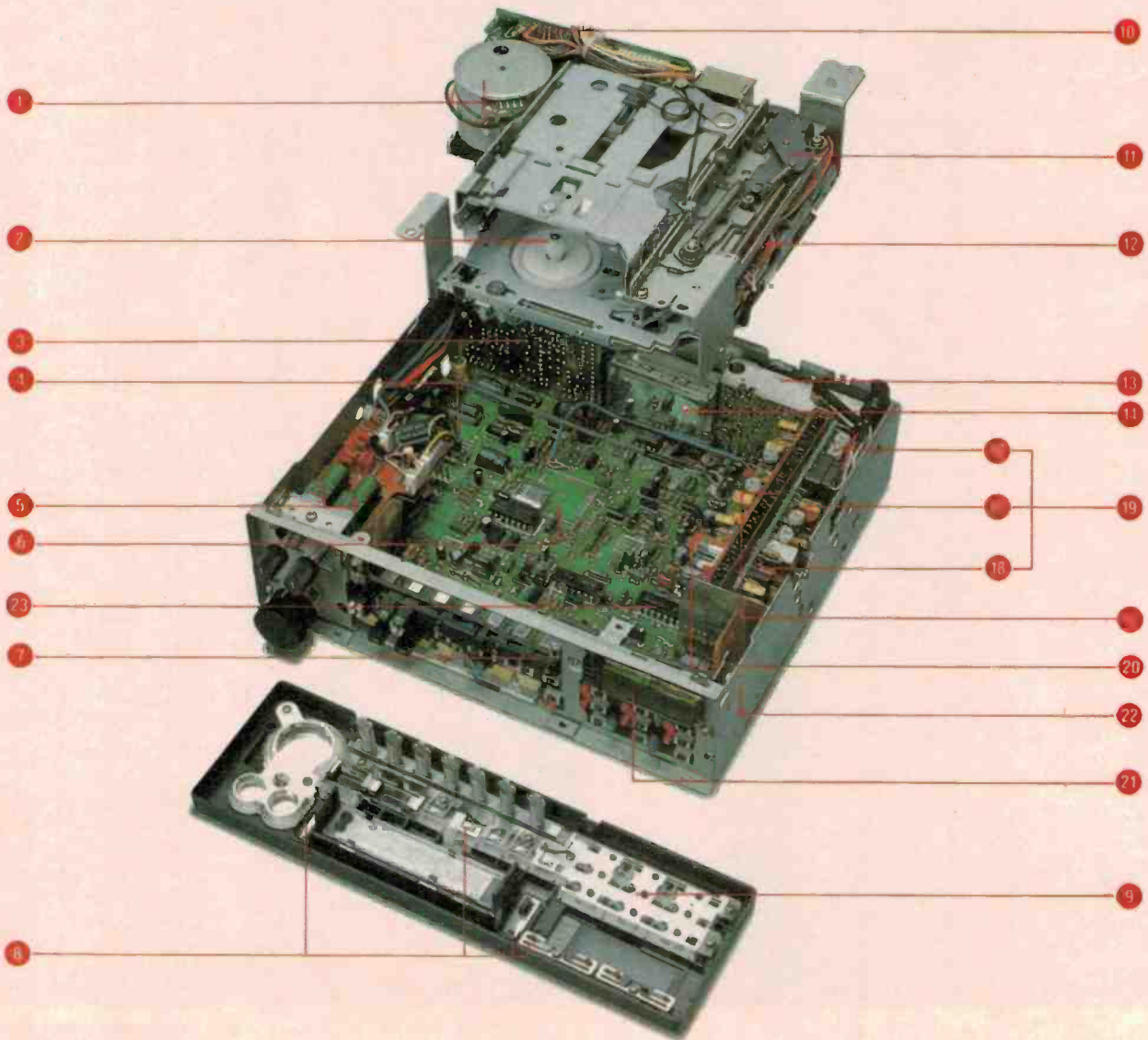

CAR AUDIO

Putting sound into your car is probably a decision more fraught with possibilities than originally buying the car. You can spend virtually any amount of money you like, from \$50 to \$5000 and get genuine high fidelity sound right through to kettle drum acoustics. That high quality and high price don't always go together only makes choosing the right system for your car more of a challenge.

Jon Fairall

THIS ARTICLE DOESN'T set out to make you an expert in car hi-fi. There is no such thing, the occasional guru excepted. Hopefully though, we can look at some of the trends that have them raving in the car shops, and also some of the more important issues in designing a music system for your car.

Trends

The first car radio was developed by Motorola in the mid 30s, not long before the first 'Genemotor' car radio was launched by AWA in Australia. The first generation

radios used the same technology as in home radio, so high current and voltage was the order of the day. Supply voltage was 200 V and current drain from the car's six volt battery was around 10 amps. This power was supplied by a 'genemotor' driven from the vehicle's battery; it was a device about three times as big as a modern alternator. An additional battery was a common feature, installed after flattening the starter-motor battery once too often.

There were also a couple of other large metal boxes required to house the receiver and speakers. In the early setups all this was

situated in the boot, or under the seats, and a remote controller was located on the dash. This communicated with the boxes via a bowden cable.

Antennas posed a special problem, as they were both long and heavy. Common solutions were to locate them under the running boards, or else bolt a dipole to the roof, so that it looked like a roof rack.

All this was worth considerable amounts of money. But then you needed to be in the top few per cent of money earners to be able to afford a car anyway, so possibly that didn't matter. Such radios also broke down ▶



Latest styling from Aiwa: the bottom panel folds up.

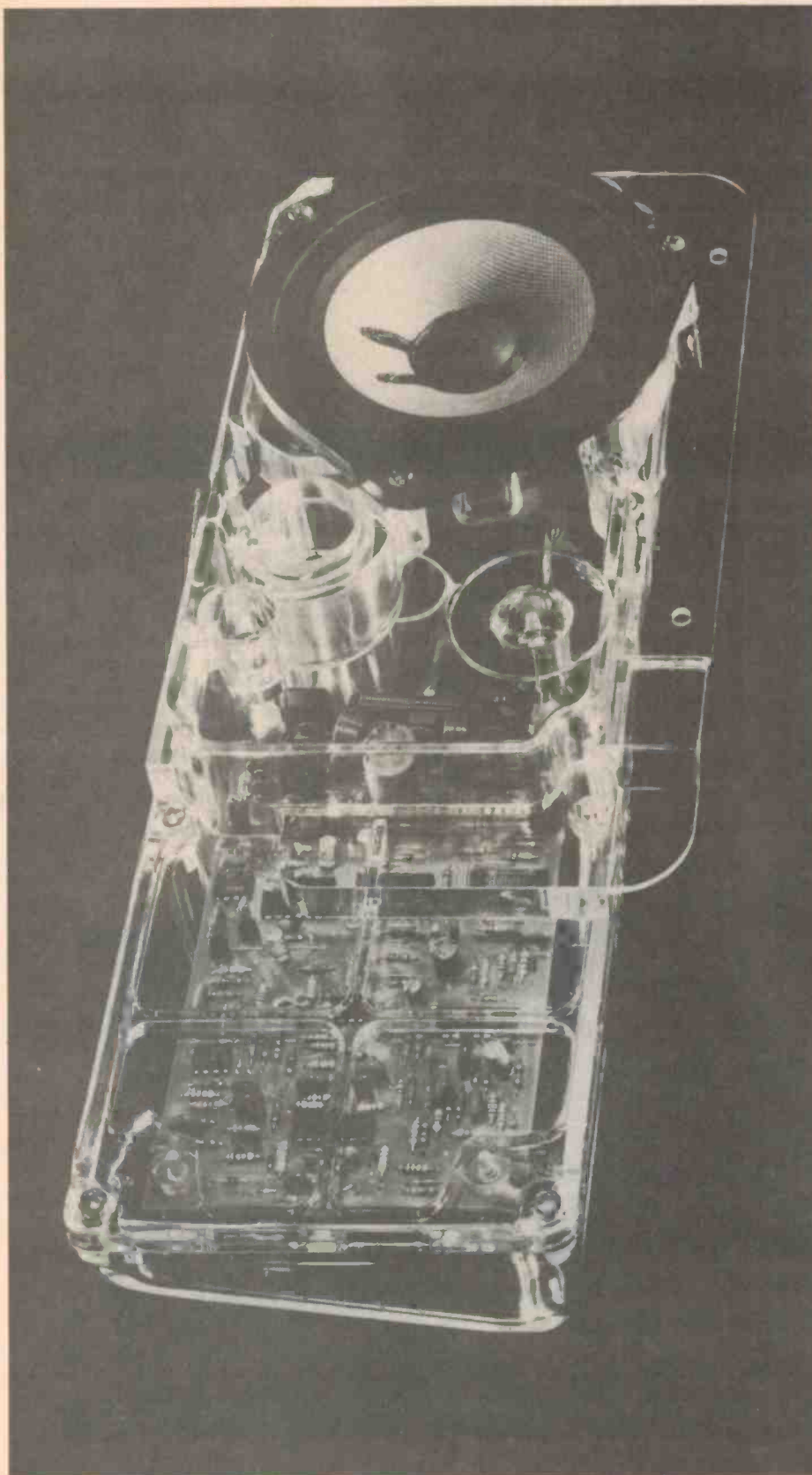

Inside the Bose 25 watt speaker amplifier module.

with annoying regularity, but then so did the cars, and doubtless grandpa and grandma were philosophical about that as well.

With the war, car radio quickly became part of mobile military communications, money poured into the industry, and car radio became cheaper, smaller and more reliable. But really, it was the transistor and the pcb that unleashed the potential of modern radio. Both happened in the mid 50s. As a result, voltage and power requirements dropped dramatically. The use of circuit boards meant smaller assemblies and more reliable performance.

In the 60s the idea of using pre-recorded material was born. Initial thoughts were to develop a mobile record player, and development attempts continued for many years, but with little success. The problem of protecting the playback arm against vibration was simply too great.

An alternative was the introduction of tape cartridges. This was a variation on the theme of open reel-to-reel tape recorders which were very popular at the time. Eventually this was superseded by the modern cassette using much smaller tape and slower head speed, but with vastly improved circuitry.

Throughout the 70s the trend was towards increasing fidelity and reducing power and space requirements. Both objects were aided by integration and new concepts in audio design, particularly digital control of the audio path. The advent of FM gave designers an excuse to chase new heights in hi-fi reproduction, which they did with considerable success. By the late 70s top of the line car audio products had performance figures not very different from home models.

In the 80s the trends have changed somewhat. Having refined the designs to the nth degree designers are now using micros to add on features. The technical ability of the manufacturers has reached such a stage that further increases in fidelity are rather pointless, especially given the ambient noise in a typical motor car. In fact the modern problem seems to be to determine what features are worth paying money for, and which are just sales gimmicks.

You don't have to pay very much to find a tuner that will remember your favourite frequencies and jump to them, or play your favourite tracks in some predetermined order. Digital readouts that double as clocks are also popular toys. Infrared remote control is also available, so the back seat passengers can control the action. In fact, on many a modern car radio, knobs and buttons have multiplied like rabbits. And such devices are ergonomic disaster areas, almost impossible to operate without taking your eyes off the road.

Probably the two developments that have most people talking are compact discs and

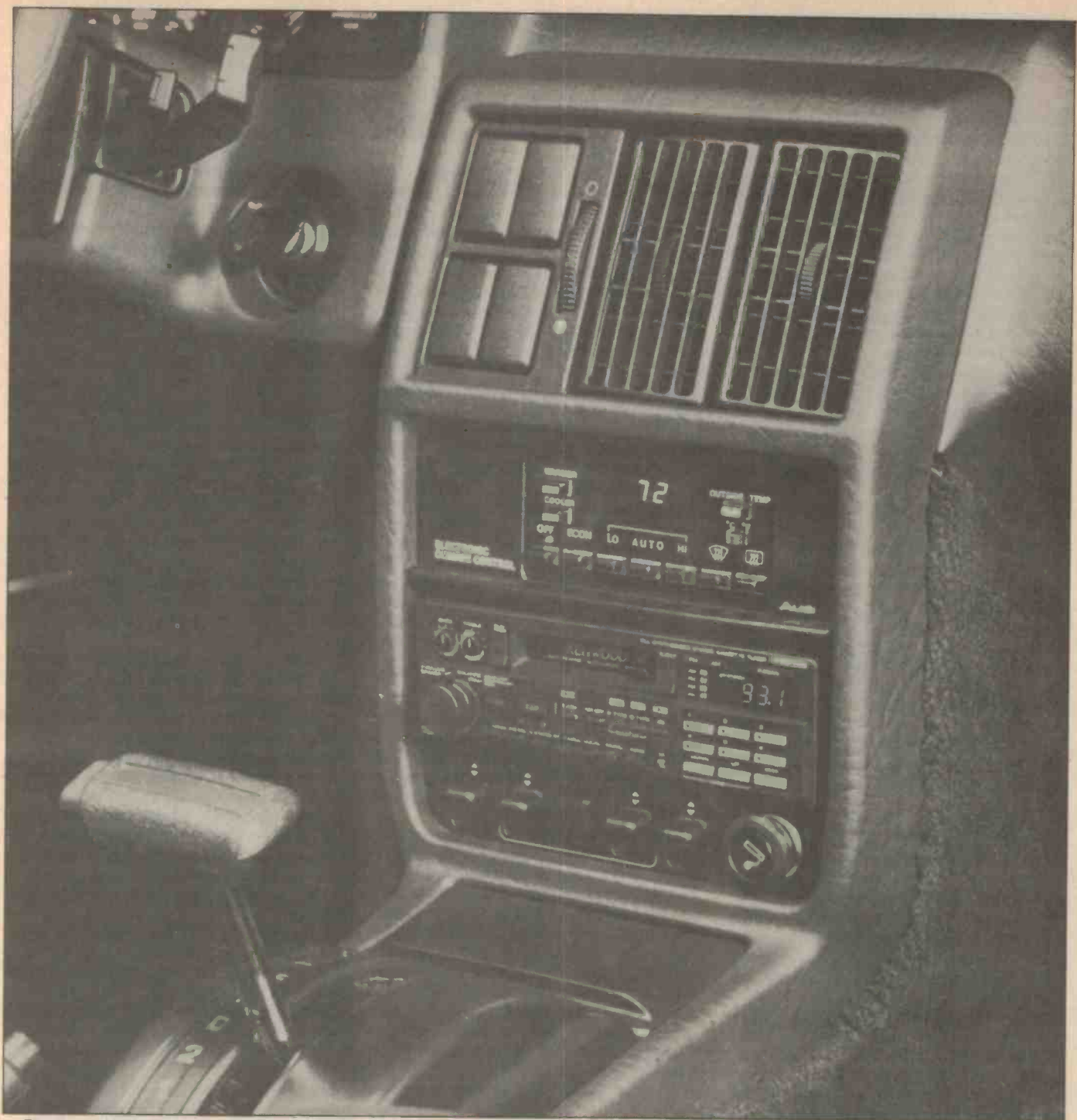

Fits like a glove!

AM stereo. There have been significant developments in receiver front end technology as well. Down the line, power amplifiers are getting bigger and bigger as time passes. Speakers are getting more sophisticated too, but only in the hands of some manufacturers. Some speakers are of more interest to interior designers than people who want decent music.

Compact discs

The compact disc is the new glamour technology of the hi-fi industry, and with

justification. It has fantastic signal-to-noise ratios and enormous dynamic range. A few eccentrics maintain it adds colouration or 'digital noise' (whatever that may be) to the signal, but for the most part, people who have listened to them agree they spell the beginning of the end for vinyl.

Another criticism is that it mistracks when encountering bumps on the road. This may have affected some very early development models, but it is a bit of a red herring now. Of course, any CD player will mistrack if you apply sufficient force to it, but

it seems that you would break the car before breaking the music. In fact, one story doing the rounds concerns a nameless reviewer who ripped the suspension out of his shiny new demonstrator in an attempt to prove that CDs were susceptible to mistracking.

Notwithstanding all this however, a CD player is probably not a good buy for your car, yet. Unfortunately, the very things that make CD worth having are things that cannot be appreciated in a car. Exceptional signal-to-noise ratio is hardly a bonus in a car where the ambient noise level might be of ▶

the order of 80 dB or so.

Exactly the same consideration applies to the question of dynamic range. Who needs it? When the car is so loud, dynamic range is simply an embarrassment. To see why, consider that if the ambient noise is 70 dB, the quietest passage in the music must be at least 70 dB itself. But this means the loudest part of the recording comes in at about 140 dB, allowing a 70 dB S/N for the CD. This level is well above the pain threshold, and would probably send you deaf, well before the end of the song.

Clearly, one would like the loudest parts of the music down at a comfortable listening level, say 90 dB at best, with the quietest parts of the music still accessible. This suggests a dynamic range of 20 dB. It's a figure that underlines how bad a listening environment the car is.

Another consideration worth remembering is that most CD players need a powerful amplifier to get the most from them. Because the dynamic range is so high, the CD is passing transient signals considerably higher than the rms value of the music coming out of it. If you want the transients you need an amplifier capable of reproducing them. Even if you don't want to pin your ear to the back of the seat, you might still need to consider installing a 100 watt amplifier in your car to derive any real advantage from a CD. Certainly the claim that a CD can simply be plugged into your existing system is quite wrong, unless you have the power available.

These considerations have made the audiophile community less than enthusiastic about CD in cars. Businessmen in the industry have their reasons for disliking the disc too. Among these is an enormous investment by the public in tape systems which constitutes a lucrative market to play with. Many car owners have access to huge libraries of tapes, irreplaceable on disc. So the trend is to try to make tape systems more attractive to the buying public. Store owners and manufacturers are betting that it will only be when the public has made a considerable investment in CD at home that market demand will force a wide range of CD players on to the car audio market.

AM stereo

"The biggest non-event in broadcasting history," says Garry Crapp of Dick Smith Electronics. Judged by the amount of product around, Crapp has a point. Almost a year after the launch of AM stereo there is still a dearth of manufacturers with product ready to sell to the public.

Superficially, the idea of AM stereo makes sense in a car. AM doesn't suffer from multipath distortion as does FM. It's far less affected by tall buildings in an urban environment. It travels further than FM and at night it's very much better. Add to that the fact that there is no reason why basic cri-

teria like bandwidth should not be the same in both FM and AM, and AM starts to look very good indeed.

But there are problems. Firstly, AM stereo demands a very stable local oscillator to extract the sub-carrier. The only practical method of achieving this is a synthesised front end, with a PLL. But this in turn imposes a price floor on stereo AM. According to some people it adds a good \$200 to the cost. In the competitive marketing world of car radio that is not insignificant.

Another problem is found in the behaviour of some of the AM broadcasters themselves. Some broadcast a compressed signal so as to maximise the sound quality received by the \$10 trannie brigade. Given the rotten quality of most existing AM receivers this makes good sense. The disadvantage is that the sound out of good receivers suffers. In particular, it makes it difficult to compete with a good FM system.

The result has been slow movement of AM stereo product off the shop floor. The expected boom in sales has not eventuated, rather it seems that as it comes time to re-equip, buyers will specify AM stereo if it's offered to them. Few will go out of their way to get it.

Tuners

In a way though, AM stereo is a product of its time, in particular because of its requirements for a synthesised front end. During the last few years the tuning circuits of all types of radios have become digitally created and controlled.

This has led to automatic search functions, in which the frequency is wound up in precise 9 kHz increments right through the AM band until the unit senses a sufficiently strong station. Nine kilohertz is, of course, the standard spacing of AM stations in Australia. The equivalent of FM is 100 kHz. Because of the accuracy of the PLL it is possible to precisely tune to the centre frequency of the station every time.

This type of technology also leads naturally to digital storage of frequencies. Many receivers now offer a store of perhaps five or 10 separate AM or FM channels. Often it's possible to program the unit to step around selected frequencies in a particular way. Other units will enter an auto search mode whenever the selected channel becomes too weak to give a signal strong enough.

Speakers

When all is said and done however, the real determinant on how good your unit sounds is the speakers. Conventional wisdom holds that you should spend half the money of a hi-fi system on speakers, and that probably holds true in car systems as well. Not that the speakers themselves are expensive; quality speakers retail surprisingly cheaply. Rather the problem is that in

a quality car system you need a lot of them.

How many and where? This is probably the most debated question among the fanatics. The answer ranges from a single speaker on the dashboard, right through to six speaker systems, in which all the doors and the back parcel shelf carry one or more. The things affecting your decision range from the prosaic to the highly technical. For instance, if you put speakers on the back shelf, will your back seat passengers be over the pain threshold when you are barely able to hear?

On the other hand, if you are after a more complex setup, how should you divide the speakers up? Received wisdom seems to be that you increase frequency as you go forward, so the bass goes in the back, the treble in the front. It seems that the interior of a car looks very absorbing to high frequencies, so what you want is direct line of sight between you and the tweeters. Bass, on the other hand, will resonate around the compartment, so its placement relative to the driver is not so critical. Putting them on the back parcel shelf has the advantage that the boot then functions as a speaker enclosure.

However, you need the power to drive the speaker for this theory to work. It really has negligible effect if you are looking at a typical 5 watt rig. One solution, achieved by KEF and Bose at least, is to put large, say 12-inch, speakers in the boot, drive them from a separate amplifier, also in the boot, and then duct the sound into the car via a snorkel up to the parcel shelf, where it is covered by innocent looking speaker baffles. Given sufficient power the speakers also cause the sound to resonate the back seat, thus giving a really sensitive base response.

This type of solution appeals to many, but it has a price. A lower cost option being exploited by some manufacturers, is to mount a base speaker flush with the parcel shelf, and then have a tweeter projecting above it. The direction of the tweeter can be changed with steerable vanes on top of the enclosure. The advantage of such a set up is that it makes it possible to project the high frequencies at the driver while still preserving the proper base response.

In the final analysis there are no correct answers to questions like: "What speakers are best?" or "Where should I put them?". It's entirely subjective. This is unfortunate because it's difficult to check before you buy. Store front displays give precious little information, except as a guide to the maximum quality you can expect. It will always sound worse in the car. One way out is to listen to other people's rigs, especially in a car like you own. Another, the oldest trick in the book, is to ask questions and read all you can before you buy. It's no guarantee you'll like the result, but at least you'll know more. ●

Lamborghini style...



...Alpine performance



ACTUAL SIZE



When it comes to sound "on the move," Alpine technology gives you the choice... cassette, or disc. Either way, your music will sound as good on the road as it does in the home.

Model 7273E Cassette Radio. Highlighting: Preset scan tuning • Up/down seek tuning • Auto metal capability • Dolby B & C • Tape blank skip • Bi-level • Auto dimmer lighting • Recommended retail price \$799.

Model 5900 Compact Disc Player. Highlighting: Stabilized mechanism for precision performance • Key off pause • Repeat one or all tracks • Music sensor • Full logic I.C. control • Compatible with Alpine Bi-level cassette radios • Recommended retail price \$1299.

* Dolby is the registered trademark of Dolby Corporation (USA).



ALPINE

car audio systems

Prices subject to change without notice.

ANI/6242

Another fine product from Anitech a division of the ANI Corporation (Inc. in NSW)

Eliminate hot sites faster. HP's complete family of protocol analyzers. All compatible.

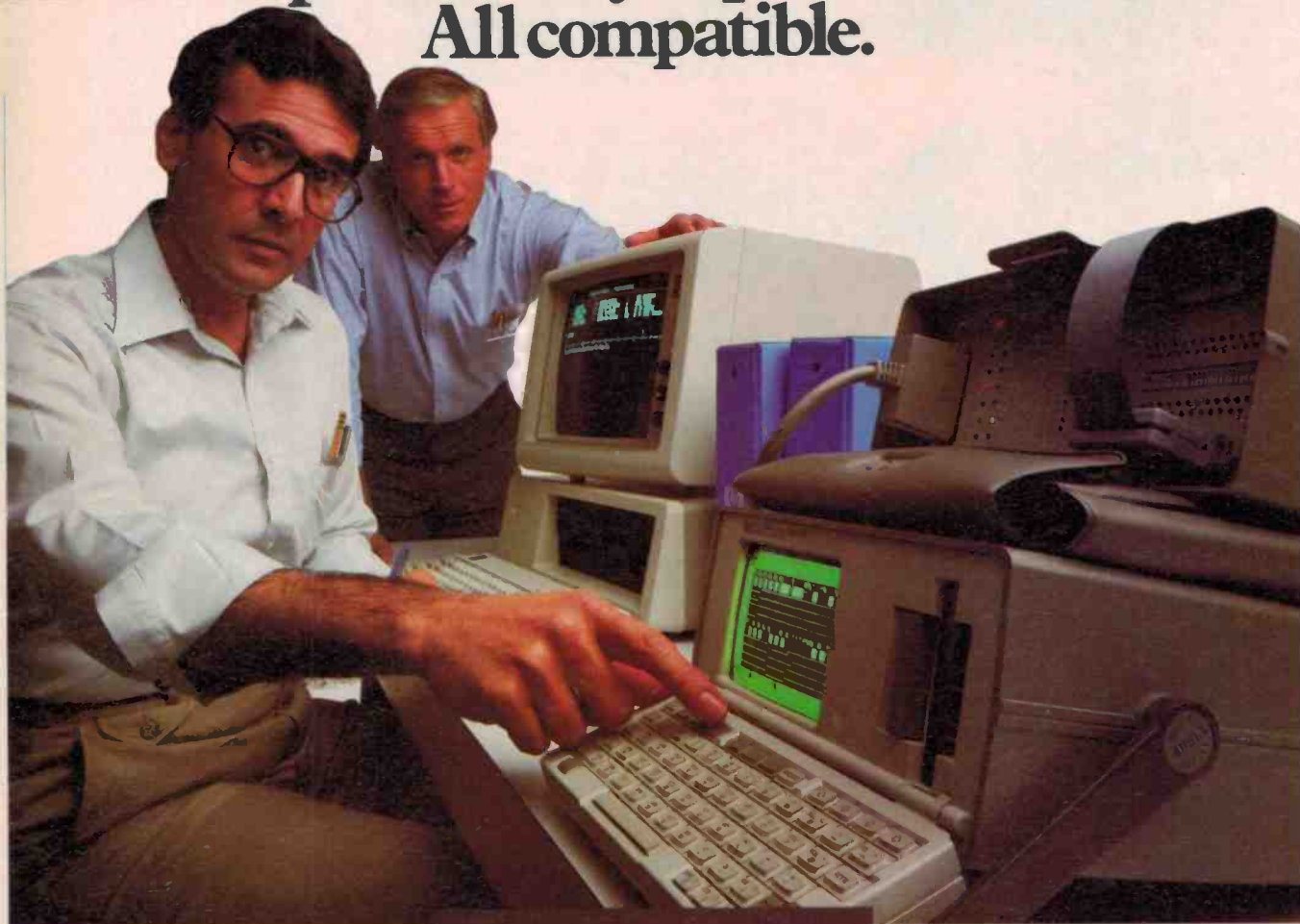

HP is the first company to offer you a complete family of protocol analyzers that are all data-compatible. Now, you can quickly identify and solve network problems — without having to recreate them for analysis at each organizational level.

Clear lines of communication with remote capability

For the first time, you can have a clear line of communication from the customer's hot site to your district or regional service center — even to R&D if necessary.

All HP protocol analyzers permit remote transfer of data and test programs, so you have high-powered analysis wherever you need it. Captured data and test programs written on one HP analyzer can be transferred to any other remote unit.

Now your field service personnel have direct access to the technical resources they need to solve even the toughest problems



in the shortest possible time — no matter how dispersed the network is geographically.

Software extends flexibility

With three HP protocol analyzers to choose from, you don't have to buy any more performance than you need. You are also assured continuing software support — a comprehensive package for X.25 certification and testing as well as powerful decode and simulation packages for SNA, X.21, CCITT #7, and the other protocols you need.

Quick and easy measurements

All HP protocol analyzers feature a common human interface — menus, decoded displays, ASCII keyboards, and softkeys that quickly and easily guide you through your measurements. Learn how to use one HP protocol analyzer and you can use them all.

For details about the HP family of data-compatible protocol analyzers, call Hewlett-Packard.

Melbourne: 895-2895,
Sydney: 888-4444,
Adelaide: 272-5911,
Perth: 383-2188,
Brisbane: 30-4133,
Canberra: 80-4244.



**HEWLETT
PACKARD**

BOSE®

Mobile Music Systems High performance options that won't get you a ticket.

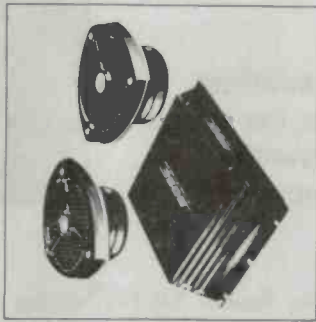

1201 Door-Mount System
50 watt amp, 2 x 4 1/2" speakers.
Two speaker system for
smaller vehicles \$520 r.r.p.*

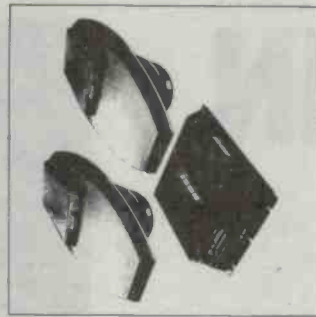

1201 Rear-Deck-Mount System
50 watt amp, 2 x 6" x 9"
speakers. Two speaker system
for larger vehicles. \$609
r.r.p.*



1401™ Small-Vehicle System
100 watt amp, 4 x 4 1/2"
speakers. Four speaker system
for smaller vehicles \$926 r.r.p.*



1401 Large-Vehicle System
100 watt amp, combined 4 1/2"
and 6" x 9" four speaker system
for larger vehicles \$1008 r.r.p.*

*Prices current at time of publication 1/3/86

BOSE®

Better sound through research.

Bose Australia, Inc. 11 Muriel Avenue, Rydalmere NSW 2116 (02) 684 1022

ETI READER SERVICE 143

WIN THIS SUPERB SONY CAR HI-FI WORTH \$1827



- Compact disc player/tuner
- 60W + 60W power amplifier
- Three-way 100W bass reflex speakers

You could easily win this fantastic car entertainment system from Sony. This is REAL high fidelity delivering 90dB of dynamic range at up to 60W rms. There are no questions to answer and nothing to buy. You can simply send us your details on the form below.

THE PRIZE INCLUDES:

CDX-R7. Sony's top car CD player comes with an AM/FM digitally controlled tuner. XM-700 60Wrms per channel power amplifier. XS-700 three-way bass reflex speakers — Sony's top car speakers.

No purchase required

To enter send details to: Sony car hi-fi
ETI
140 Joynton Ave
Waterloo NSW 2017

Name

Address

Telephone ()

SHOWTIME IN LAS VEGAS

— Winter CES

From the showtime capital of the world come the smallest TVs, the most portable CDs, the loudest speakers, the shape of things to come. The expansive Las Vegas Convention Centre packed in what's new for 1986, from the most useful to the most singular.

WHEN IT COMES to ranking 'display cases' of new electronics, the Consumer Electronic Show (CES) in Las Vegas is 'cock of the walk'. With over a million square feet of effective display area and more than 100,000 visitors, this year's CES in Las Vegas between 9 and 12 January 1986 must rank as the most important display of new products and avant-garde technology.

From the moment I entered the Las Vegas Convention Centre, with its cavernous halls (and its simultaneous acquisition of all of the huge Sands and Hilton hotels) I was surrounded by scurrying crowds of Americans, Japanese, Koreans, Europeans, Arabs, Chinese, Indians and even a few Australians. All had made their pilgrimages to this 'electronic holy of holies' to view the new releases, many of which had been specially readied to meet the show deadline.

CD players

My first and strongest impression was that CD players have finally gained total supremacy in the hi-fi market and nowhere was this more evident than in the displays of both low cost and high priced equipment. CD players are now being incorporated in the latest two-in-ones, three-in-ones and boom boxes or ghetto blasters which have been developed to pander to the tastes of the younger generation.

Some of the more enterprising Japanese manufacturers have even released double cassette recorders, complete with a CD player, which I presume are intended to allow you to copy your CD discs straight on to cassette tapes to distribute amongst your friends. This of course leads to very serious copyright problems.

The most interesting CD players were the small portable versions released at the

show. These included the Toshiba XR-J9 (selling at \$US199.95), the XR-P9 (\$US299.95) and the Sanyo CDP-10 (\$US249.95). The Sanyo MCD 40 is slightly more expensive at \$US399.95 and as well as incorporating a CD player, also contains a cassette player, AM/FM tuner and integral speakers. *Wow!* That act, and at that price, may initially prove a little difficult for some of the other manufacturers to follow. The MCD 40 is also designed for interconnecting with your main system or, better still, good speakers.

Apart from Sony with the CD5, other manufacturers which have released new, small version CD players include Panasonic with its SL-NP3 (selling at \$US259.95) and the RX-CD70 which contains a CD player, twin auto reverse cassette players, AM/FM tuner and removable twin speakers for only \$US599.95 (RRP).

Philips and Magnavox (USA) also released a palm-sized CD-9510 CD player (\$US300) at the exhibition and Aiwa is also releasing a miniature unit.

The number of well-known manufacturers which have released conventionally sized CD players is quite astounding. Much to my surprise these included Shure Bros of Illinois (with its D5000) and Dual of Germany; presumably both of these companies' record player/cartridge sales will soon be decimated by the inroads of CD sales. These releases are just a further tacit admission by each of those firms that the 'record player' has now been eclipsed by the CD player.

I took the time to listen to a number of the low priced and portable units and was very impressed by their performance, particularly when the selling price and size were taken into account. Most of the people



Louis Challis

visiting the displays with me were equally impressed.

One interesting problem that all the manufacturers with high priced CD players were experiencing has been generated by their aim to seek distinction in a perfect CD world. All had the problem of setting about differentiating their brand or model from the next manufacturer's. With CD players, that is not a particularly easy task as the industry has done such a good job in explaining the perfection of CD sound reproduction. As a consequence, most consumers now believe that all CDs are perfect and hence it matters little which brand you buy.

To overcome this 'problem' manufacturers are resorting to various formulas. The most obvious one at the show was to stress the company's experience in a particular product area. Thus, for example, Denon stressed its original development work in PCM recording; Sony stressed its original development of the CD system; NEC stressed its 'related' experience in satellites and computers. Now I ask you, what do satellites and computers have to do with CD players and advanced PCM digital technology?

Technics took a more interesting tack, after more or less conceding the perfection of the generic CD technology. Its large display ads go on to say: "Occasionally, even the musical perfection of CD can be marred by fingerprints, dust or scratches. So the SL-P2 has improvements such as . . ." The ads make their main point — that Technics has found a way to improve upon perfection.

One of the most closely guarded of displays was the Sony model CDXA10 boot-mounted, multiple-play CD player, into which you load the CD discs you intend to

play and select them from the control panel on the dashboard of your car. This particular panel control is intended to be stalk-mounted so that it is accessible from the rear seat of the car for even greater convenience. The boot-mounted feature offers obvious advantages in terms of reducing the risk of theft, quite apart from avoiding the inconvenience of trying to load a CD disc into a small slot on the dashboard of your car, especially when driving in heavy traffic.

Pioneer was also displaying a six disc player which is virtually a miniature juke box for home use. It attracted considerable market interest and is expected to be a big seller in USA in 1986. Nikko released an even larger unit (NCD-600) which holds 60 CD discs and provides for access of 55 selections, in any order, from the 60 discs. The NCD-600 can have a further three CD store units added to the main module to provide for storage and playing of 240 discs, the programming of which can also be interfaced with a computer for infinite program control.

Philips and Magnavox also displayed a particularly interesting CD player (CD650) with very simple user accessible memory encoding capabilities. Once encoded, these remember which preferred tracks should be played on any specific disc and skip the rest. This memory uses the disc encoding data which is recorded on the central annular ring of discs and which you probably, like me, did not realise has been incorporated for that specific purpose.

There was an astounding number of other manufacturers displaying CD players, many of which were worthy of special mention, some of which you will see reviewed in this magazine over the next year.

LCD televisions

Amongst the most exciting 'sci-fi' — Dick Tracey comic strip-type' releases at the show were the new LCD pocket televisions which have been specifically designed for the large NTSC system market. All of these incorporate manual tuning for VHF and UHF bands and all are so small that they drew crowds of interested viewers, many of whom were pleasantly surprised by the quality of picture.

The most exciting of these to my mind, was the Panasonic CT-301E, a 3-inch (diagonal) colour LCD 'pocket-watch' television set (RRP \$US299). The cheapest LCD TV was the Citizen 06TA, (which is only black and white) selling for an unbelievable \$US99.95. The Citizen 3.5 inch (model 08TA) personal television also incorporated FM stereo sound and sells at \$US159.95.

The Seiko 2-inch black and white TFT pocket TV was the smallest TV set I have ever seen with dimensions of only 116 mm x 69 mm x 22 mm overall, weighing less than 250 g.



Sanyo MCD40 incorporates CD player, AM/FM tuner and speakers.



Sanyo CDP-10 portable.

While each of these three miniature TVs has been priced to sell, it was clear that the Panasonic CT-301E offers the most attractive format and has the most sensible user controls and functions. Although the screen is not the largest, the size of the unit and the picture quality is the best of the three, particularly with the screen's ability to be tilted when out of doors and thereby use daylight rear-illumination. This capability is further enhanced by the high contrast picture which the unit provides, as well as the resulting savings in battery power gained through the use of the tilt-up display.

Electronically, the Panasonic unit is a true 'state of the art' piece, as the picture display uses 89,280 individual picture elements in the form of a 240 x 372 pixel display. The display uses a thin film transistor (TFT) active matrix system, which because separate transistors are used for each separate pixel, is able to display subtle variations in hue and colour intensity. The unit has been designed for four-way operation so that it will run off an ac adaptor, optional nickel cadmium rechargeable battery, car adaptor cord or from six internal alkaline batteries which provide for three hours of self-illuminated display or 5.5 hours of out-

door usage. The Panasonic 'pocket-watch' TV contains its own antenna and speaker, and will be on sale in the USA early in May. My probing revealed that a PAL version of the unit (and subsequently a SECAM version) is not expected before mid 1987 at the earliest.

Video

There was an astounding number of releases of new video equipment from almost every major manufacturer displaying wares at the CES (including those which had not previously marketed video equipment). The one that had the attention of the reviewers on the day I went to Las Vegas, was Toshiba's release with a 1.15M bit memory to freeze pictures without bar noise or any other trace of screen jitter.

Toshiba also released a new digital TV chip to achieve another break-through in video receiver quality. This had virtually all the technical reviewers that I knew flocking to the special display in the Sands Hotel. Regrettably, my limited time at the show precluded me from attending, although a subsequent hurried discussion with some of the attendees confirmed the manufacturer's

FEATURE

claims for the improvements in video quality.

Sanyo released seven VHS VCRs at the show and as a consequence is now the first and only manufacturer to be marketing VCRs in all three formats (VHS, Beta and Video 8). That is more than a claim to notoriety because Sanyo has backed it up with unbelievably low prices and the latest technological advances.

Videodisc

A number of manufacturers released laser disc players to compete with Pioneer, which, until recently, has virtually had the laser video player market to itself. Pioneer has, of course, not rested on its laurels and its latest video disc player, which I viewed at the show, provides a video signal which is absolutely superb and matched by a stereo audio signal even better than the video sig-

nal. This particular video player has also been designed to play CD discs, although I do not really see why the two units should be combined into one. The lack of readily available video software still constitutes the biggest restriction to the sale of these units, which find their largest market in dedicated training applications for industrial and military users, as on-the-job training aids for specific assembly and repair operations.

Car audio

There was a number of exciting loud-speaker developments and new releases at the show. First and foremost amongst these was the range of 'in-boot' speaker systems being marketed by KEF of England, Cerwin-Vega of America and Sony of Japan. These units use reasonably sized proper speaker enclosures mounted in the boots which are coupled to the car through flex-

ible spiral ducts so that they achieve low frequency performance (and sound levels) designed to 'electrify' you in much the same way that your home hi-fi speaker system should.

I sat in a car in the Sony display and heard its boot-mounted CD player system for which superlatives fail me at this moment. It is clear that the boot-mounted speaker system is going to be the talking point in car hi-fi sales over the next few years and that many other manufacturers will follow this lead when developing new systems.

The number of new manufacturers of car audio systems was almost as astounding as the numbers who have entered the field of video. Many were also offering car CD players and all believed that car audio would prove to be 'their break-through' in sales in 1986. It is my salutary observation that with so many new manufacturers competing for the same small segment of the market, their chances of all making good would be increasingly difficult.

Bose was one manufacturer in particular who was apparently doing it right working in conjunction with the 'General' (General Motors). They have together released a new range of car speaker systems which were one of the talking points of the show. By contrast, JBL is working with Ford on the development of the sound system for the 1986 Lincoln Continental (and other Ford models in 1987). Those particular products are expected to reach Australia late in 1986.

Loudspeakers

In the field of conventional loudspeakers, two speakers in particular shone through. One is the new KEF model 107 reference series which has not yet reached Australia. The design of this system obviates my criticism in ETI December 1984 of the KEF 104/2 series primarily through the use of an active base equaliser to enhance the low frequency end of the spectrum. I briefly listened to these speakers with Raymond Cook, Managing Director of KEF, and believe that they may well achieve the performance which the 104/2s did not quite stretch to. I was advised that Dr Richard Small from Sydney University and one of the world format experts on speaker design has just joined KEF.

The other exciting speakers on display at the show were the Sawafuji Digital 20 loud-speaker and the Sawafuji Digital Reference speakers. These use a super-thin, ultra light-weight, flat wave ribbon tweeter based on teslan plastic/magnetic material. These speakers offer an acoustical performance which is in many respects comparable to that provided by the Quads, but with a low frequency performance which is claimed to be better and which certainly sounded better.

JBL introduced a new series of automo-

Citizen 06 TA black and white LCD TV.



Exciting Panasonic CT-310E three inch diagonal colour LCD TV.

ALARMING THE PUBLIC

One other aspect of car electronics received more than its fair share of attention at the show. This, of course, related to 'anti-theft' electronics which is apparently just as important in America as it is in Australia!

There are a number of new approaches being taken to this problem in America. The first, and one of the more expensive, is to install a system put out by Auto Page Inc called the Vehicle Theft Sentry Audible System. This automatically disables the engine, operates an audible alarm or transmits a radio frequency signal to a remote location. The unit also provides interface capabilities to enable remote receivers and/or disconnection of various vehicle functions at the discretion of owner or user.

Another system which I saw demonstrated with audibly disturbing consequences was a system which alerts other passerbys to the imminent theft of the vehicle or its contents. The raucous statements include: "This car is being stolen!", "Call the Police!", "Note the number of the car before it is driven away!". All of this, it should be noted, was generated at sound levels approaching the pain threshold and with a voice that had a gravel like quality which I felt was more disturbing than the level of the sound. It is possible that the system designers specifically intended to produce that type of characteristic to gain the listeners' attention and that it most certainly did. I found this display was so disturbing that I could not bear to stand around to collect any more details on the system design or price.

There were many other car alarm system variants being offered, and many of the car systems designs are now based on the concept of removing the main module from the dashboard at the time of departure, and thereby discouraging the would-be thieves from breaking into the car.

tive loudspeakers with titanium domes for its high and mid frequency transducers. These achieved a transient performance one order of magnitude superior to the previous units that JBL were marketing. I listened to a demonstration of these speakers and was suitably impressed not only by their power handling capacity and their transient performance, but also by their ability to blast me out of the car in which they were being demonstrated.

Satellite

The most exciting satellite receiving systems were the small satellite dish antennas and associated down converters which enable the purchaser to receive satellite broadcasts from roof top or backyard. The cheapest of these was only \$US895, at which price very few intending purchasers would be discouraged. The more expensive systems went to five-digit figures and obviously provided better performance and greater flexibility.

At the time it was still possible for a purchaser of one of these satellite receivers to receive cable television signals without paying the mandatory fee. However, I understand that in the following few weeks the cable TV programs were to be pre-encoded requiring a decoder unit from the cable company.

I viewed the signals provided by a num-

ber of these satellite reception units and initially found it very hard to believe that what I was seeing was not a hard-wired signal from a video recorder.

Sales of these satellite receivers in the US have been unusually brisk this winter, because of the large number of people who are located between stations, particularly in valleys and in other difficult locations beyond the normal TV viewing area. It is apparent that these specific attributes should create a reasonably good market for similar equipment using the new Aussat satellites in geosynchronous orbit over Australia.

Miscellany

Amongst the more unusual small items being marketed at the Winter CES was a Search & Dial cordless telephone directory that looks for all the world like a small hand calculator. This unit also allows direct dialling and last number redialling of up to 200 telephone numbers which are recorded in its memory.

The auto dialling function avoids the need for any direct electrical connection, and instead utilises an audible voice frequency tone dialling emission, the signals of which are transmitted through the telephone mouth piece in an analagous way to the system used by the telephone's internal voice frequency dialler. (This will of course only work on those telephones connected to

a VF tone dialling exchange.) This system is both neat, innovative and relatively inexpensive with prices ranging between \$US49.50 to \$US69.50.

A couple of other unusual consumer items caught my eye at the show. The first was the Keyfinder II. This unit dispenses with the whistle, which not my secretary, my wife or I can ever master correctly, when searching for our existing Keyfinder and replaces the whistle requirement (at the correct pitch) with a sharp hand-clap or crack! The Keyfinder II responds immediately. This characteristic is far easier for most people to generate and it will undoubtedly replace the conventional Keyfinder.

The second item was the Carfinder which has long been sorely needed by car owners searching for their cars in large parking stations. When the small transmitter device is operated, your car beeps its horn and flashes its lights. This solves the problem of finding your car when it is surrounded by dozens or even hundreds of other cars. The unit really works and will undoubtedly become one of the new conversation pieces for car owners in 1986.

In the field of computers and associated software, the number of new products being shown for the first time was positively breath-taking, but I will have to keep you in suspense till next month's portion of this review.



KEF model 107 reference speakers.

3 HOUR VIDEO TAPES
 1-9 \$7.95 10-24 \$6.95 25+ \$5.95

WORLD MODEM CHIP
 WAS \$49.50, SAVE \$20!
\$29.50

APPLE* COMPATIBLE DRIVES
\$199
 Apple* 2E and 2+ version now available!
\$249



PHILIPS SPEAKERS

"Unfortunately we cannot always guarantee Philips speakers to be in stock due to availability problems."
 *Rod
 Cat. C12030 AD01610 T8 \$16.95
 Cat. C12040 AD02160 S08 \$34.95
 Cat. C12045 AD70620 M8 \$49.00
 Cat. C12050 AD12550 W8 \$95.00 (or Philips equivalent supplied)



MIDRANGE HORNS

Use these quality, all metal Piezo tweeters for great top end sound in your band speakers, disco sound system, etc. Rated at 30 watts RMS, in a system they will handle over 100 watts RMS
 Two sizes to choose from:
 Size: 4" x 10 1/2"
 Impedance: 8 ohms
 Rating: 30 watts RMS
 Response: 1.5kHz - 14 kHz
 Dimensions: 102 x 267 x 177mm
 Cat. C92082 \$49.95

Size: 3 x 7"
 Impedance: 8 ohms
 Rating: 30 watts RMS
 Response: 2kHz - 15 kHz
 Dimensions: 76 x 177 x 145mm
 Cat. C92084 \$29.95
 Dealers, OEM's, etc., phone (03) 543 166 for wholesale prices.



SUPER HORN TWEETER

- Requires no crossover and handles up to 100W!
- Sensitivity: 100dB/0.5m
- Frequency Response: 3kHz-30kHz
- Impedance: 8 OHMS
- Size 96mm diameter

Cat. C12102 normally \$17.95
On Special at \$14.95



SUPER HORN

- Wide dispersion tweeter, handles up to 100W!
- Sensitivity: 100dB/0.5m
- Frequency Response: 3kHz-30kHz
- Impedance: 8 OHMS
- Size: 145x54mm

Cat. C12103 normally \$17.95
On Special at \$14.95



6.35mm STEREO CONNECTORS
 Socket Cat. P10223 \$1.40
 Metal plug Cat. P10125 \$1.40
 Plastic plug Cat. P10121 \$1.00



ECONOMY 4 CHANNEL MICROPHONE MIXER

Its size and simplicity makes this mixer very portable and easy to operate.
SPECIFICATIONS:
 • 4 low impedance 600 ohm microphone inputs.
 • Individual gain control for each microphone.
 • Master volume control
 • Power on LED
 • Inputs/Outputs - 6.3mm mono sockets
 • DC operated (9V battery only)
 • Input impedance 600 ohm.
 • Output impedance 1.5kohm
 • Signal/noise ratio 55dB
 • Frequency response 20Hz to 20kHz plus or minus 20B.
 • Weight 320 grams.
 • Dimension 148 x 46 x 86mm.
 • Torque variable range 1-220B
 • Input sensitivity 1mV.
 • Output level 90mV (at input 5mV).
 • T.H.D. 0.01%
 Cat. A12001 \$39.50



ARLEC "DISCO LITE" CONTROLLER

Give your parties a professional touch with the arlec "Disco Lite" Simply plug your light(s) into the "Disco Lite" and you've instant party life!
3 DIFFERENT MODES!
Music Mode: Place the "Disco Lite" in range of the speakers and it flashes the lights to the beat of the music!
Strobe Mode: Simply adjust to desired speed! Great for mime or theatre! The Christmas season or advertising!
Dim Mode: Allows you to dim the lights to create moods, effects etc.
 Cat. M22003 \$49.50



ELECTRONIC CASSETTE DEMAGNETISER

Cat. A10006 \$22.95



10W RMS SPEAKERS
 (exciting boxes!) At this price you can afford to put a set of speakers in every room!
 Dimensions: H 475 x W 245 x D 200mm
 Cat. C12002 Per Pair \$50.00



TDK AUDIO TAPE BARGAINS

Description	Cat. No.	1-9	10+
DC48 TDK	A11305	2.95	2.85
DC60 TDK	A11307	2.99	2.35
DC90 TDK	A11309	3.99	3.50
DC120 TDK	A11311	5.49	4.50
AD50 TDK	A11315	3.99	3.45
AD90 TDK	A11317	5.25	4.50
AD120 TDK	A11319	7.95	6.25
ADX60 TDK	A11320	4.95	4.25
ADX90 TDK	A11322	5.95	4.95
SA60 TDK	A11325	5.95	4.95
SA90 TDK	A11327	6.99	5.50
SAX50 TDK	A11329	6.69	5.77
SAX90 TDK	A11332	8.95	7.25
MAC60 TDK	A11335	8.29	7.25
MAC90 TDK	A11337	11.50	8.95
MAR60 TDK	A11340	13.50	10.95
MAR90 TDK	A11342	16.99	14.50



MAGNETIC BULK ERASER

The best and by far the quickest way to erase tapes, cassettes and computer disks! Reduces noise levels below recorders own erase head level. On/Off switch located in handle 240V AC operation.
 Cat. C14950 \$29.50



VIDEO PROCESSING CENTRE

Combination stabilizer, enhancer, distribution amplifier, RF converter, designed to enhance all recording needs. Will handle 3 VCR's simultaneously with virtually zero signal loss. Built in RF converter permits in-line connection between VCR and TV for improving recording whilst viewing.

Specifications:
 Power Requirements: 12V DC 300mA
 Inputs: Video, Audio
 Outputs: 3 video, 3 audio
 RF UHF, Channel 36
 Output Level: + - 0.3dB
 Output Isolation: More than 40dB
 Audio Output: Unity gain
 • PP300 recommended power
 Cat. A13012 only \$159



STROBE LIGHTS 12V

Available in 3 colours, red, blue and yellow. These units have a magnetic base and are fitted with 4 metres of cable terminating in a cigarette lighter plug. Ideal for displays, parties, attention getting, motoring emergencies/breakdowns etc.

Desc.	Cat. No.	Price
Blue	A15046	\$32.95
Red	A15047	\$32.95
Amber	A15045	\$32.95



AA NICADS (ROCKET BRAND)

Save up to 50% off the regular price of \$2.80!
 1-9 \$1.75 10+ \$1.65 100+ \$1.40



IC STORAGE CASE

Electro static charge proof plastic IC case with conductive sponge
 Dimensions: 75 x 130 x 19mm.
 Cat. H10095 \$7.95



JUMPER LEADS

Set of 10 high quality leads approx 450mm long. Normally \$4.95
 Cat. W12000 NOW \$2.95



TELEPHONE INDUCTION COIL

For recording or amplification 3mm plug with 1 metre cord
 Cat. A12035 \$3.95



COMPUTER AND DISK DRIVE CASES AND POWER SUPPLIES

5 1/4" DRIVES

1 x 5 1/4" Slimline Drive Case
 X11001 Bare Case \$49
 X11011 Case and Pwr Supply \$109
 2 x 5 1/4" Slimline Drive Case
 X11002 Bare Case \$69
 X11012 Case & Pwr Supply \$149
 1 x 5 1/4" Standard Drive Case
 X11003 Bare Case \$45
 X11013 Case & Pwr Supply \$109
 2 x 5 1/4" Standard Drive Case
 X11004 Bare Case \$59
 X11014 Case & Pwr Supply \$149

8" DRIVES

1 x 8" Standard or 2 x 8" Slimline, and computer Case (BB1)
 X11006 Bare Case \$99
 X11016 Case & Pwr Supply \$399
 2 x 8" Slimline Drives and Computer Case (BB1 and BB2 etc)
 X11007 Bare Case \$145
 X11017 Case & Pwr Supply \$399
 1 x 8" Slimline Drive Case
 X11020 Bare Case \$95
 X11022 Case & Pwr Supply \$159
 Dual 8" Slimline Drive Case
 X11025 Bare Case \$99
 X11026 Case & Pwr Supply \$275



GREY FLAT RIBBON CABLE

Cat. No.	Description	\$ Mtr
W12614	14 Way	\$1.90
W12616	16 Way	\$2.50
W12620	20 Way	\$3.50
W12624	24 Way	\$4.50
W12625	25 Way	\$5.00
W12626	26 Way	\$5.50
W12634	34 Way	\$7.50
W12636	36 Way	\$8.00
W12640	40 Way	\$9.00
W12650	50 Way	\$12.00
W12660	60 Way	\$16.90



LOGIC PROBE 3800A

Features 20MHz memory, TTL/CMOS operation. Normally \$29.50
 Cat. Q11272
 1-9 \$34.50 10+ \$29.50

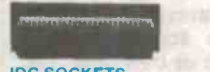

IDC SOCKETS

Cat. No.	Description	Price
P12100	10 pin IDC socket	\$2.50
P12101	16 pin IDC socket	\$3.00
P12102	20 pin IDC socket	\$3.75
P12103	20 pin IDC socket	\$3.95
P12104	34 pin IDC socket	\$4.95
P12106	34 pin IDC socket	\$4.95
P12108	40 pin IDC socket	\$5.25
P12110	50 pin IDC socket	\$6.95



BREADBOARD SPECIALS

Why pay more?
 Cat. P11000 100 holes \$2.75
 Cat. P11005 640 holes \$10.75
 Cat. P11007 640 + 100 holes \$13.00
 Cat. P11009 640 + 100 holes \$17.50
 Cat. P11010 1280 + 200 holes \$19.95
 Cat. P11011 1280 + 300 holes \$32.50
 Cat. P11012 1280 + 400 holes \$36.75
 Cat. P11015 1920 + 500 holes \$57.50
 Cat. P11018 2560 + 700 holes \$64.95



ECONOMY TRANSFORMERS

1-9	10+
2155 240V 6-15V 1A	\$6.75 \$5.95
2156 240V 6-15V 2A	\$9.50 \$8.95
2851 240V 12-6V CT 150mA	\$4.50 \$3.60
6672 240V 15-3V 1A tapped	\$9.95 \$9.30
2860 240V 15V CT 250mA	\$4.95 \$3.95



COLOUR CAPPED KNOBS

Economy knobs with elevated white pointer.
 Cat. H10001 RED
 Cat. H10002 BLUE
 Cat. H10003 GREEN
 Cat. H10004 YELLOW
 1-9 \$0.70 10-99 \$0.65 100+ \$0.60



UNPROTECTED HEADERS

Dual In Line 2.54mm

1-9	10+
10 Way Cat. P12240	\$1.95 \$1.75
16 Way Cat. P12246	\$2.95 \$2.65
20 Way Cat. P12250	\$3.25 \$2.95
26 Way Cat. P12256	\$3.75 \$3.50
30 Way Cat. P12260	\$3.95 \$3.55
34 Way Cat. P12264	\$4.95 \$4.50
40 Way Cat. P12270	\$5.95 \$5.50
50 Way Cat. P12275	\$6.95 \$6.35



SLIDE SWITCHES

Cat. No.	Description	Price
S12008	DPDT mm 2 pos.	\$0.40
S12014	SPDT mm 2 pos.	\$0.40
S12016	DPDT 2 pos alum pole	\$0.50
S12017	SPDT 2 position	\$0.00
S12018	DPDT 2 position	\$0.40
S12028	DPDT 2 position	\$0.50
S12030	SPDT 3 pos alum pole	\$0.60
S12034	DPDT 3 pos alum pole	\$0.60
S12038	DPDT 4 pos	\$0.60
S12048	SPDT 4 pos	\$0.90



UNIVERSAL BATTERY CHARGER AND TESTER

Save money on expensive batteries with this universal battery charger. Features include meter tester, and provisions for D, C, AA, AAA, N, button and cell batteries, 9V and 6V (square types). Comes complete with detailed instructions
 Cat. M23533 \$27.95

*Apple and IBM are registered trademarks

KAITEC
180 C.P.S.
PRINTER
\$449
SAVE \$75!

XIDEX DISK
SPECIALS
5 1/4" S/S \$29.95
5 1/4" D/S \$34.95

IBM*
CLONES
from only
\$899*

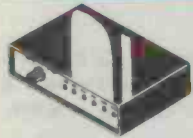

RS232 DATA SWITCH WITH TESTER
 • 25 pin RS232 "D" connectors 2 in, 1 out or 1 in, 2 out.
 • Ideal for 2 computers to one peripheral or 1 computer to 2 peripherals.
 • No power required
 • Six dual coloured LED indicators showing certain flow status:
 T.D. Transmit Data
 R.D. Receive Data
 R.T.S. Request To Send
 C.T.S. Clear To Send
 D.S.R. Data Set Ready
 D.T.R. Data Terminal Ready
 • Housed in heavy duty metal cabinet
 • Size: 200(W)x68(H)x150(D)mm
 Cat. X19110 **\$149**



NEW TTL MONITORS
 Fantastic resolution! Enjoy a crisp, sharp image with these new Ritron TTL monitors! IBM* compatible, green display, swivel and tilt base.
 Cat. X14510 **\$265**



PHOENIX 5
 Suits Apple, IBM, Commodore even your VCR!
 • Pal and R.G.B.
 • Normal Resolution
 • 13" CRT Dot Pitch 0.65mm
 • Horiz. Resol. 320 TV lines
 • Vert. Resol. 560 TV lines
 • Display Characters 1,000 Ch (40x25)
 • 16 Colours (Pal)
 • Green text display
 Cat. X14522 **\$399**



COMPUTER PAPER
 Quality paper at a low price! 2,500 sheets of 11 x 9 1/2", 60 gsm bond paper.
 Cat. C21001 **Normally \$44.95**
SPECIAL \$37.95



RITRON 1
 Our most popular model in a steel cabinet to minimise R.F.I.
 Green Cat. X14500 Save \$30 **\$169**
 Amber Cat. X14502 Save \$30 **\$179**

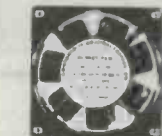

BRAND NEW FANS
 Not noisy pullouts! Stacks of uses in power amps, computers, hotspot cooling etc. Anywhere you need plenty of air.
 240V 4 5/8" Cat. T12461 **\$12.95**
 115V 4 5/8" Cat. T12463 **\$12.95**
 240V 3 1/2" Cat. T12465 **\$12.95**
 115V 3 1/2" Cat. T12467 **\$12.95**
 10 Fans (mixed) less 10%



COMPUTER CHESS!
 by SciSys.
 SciSys computer chess games are endorsed by Garry Kasparov, world's highest rated chess player, and are available from Rod Irving Electronics!

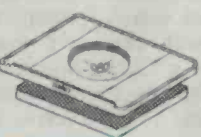

SWIVEL BASE
 Make life easier with these quality, swivel and tilt bases complete with rubber fittings!
 Cat. D11100 **\$29.50**



APPLE JOYSTICKS
 Ideal for games or word processing. Fits most 6502* compatible computers.
 Cat. C14200 **\$34.95**



XIDEX PRECISION SCREEN
 Headaches, fatigue and tired eyes are a common complaint from users of CRT's. But studies have reported that the use of the Xidex Precision Screen, actually increases efficiency 20% while relieving eye strain, headaches and general fatigue.
 Available in two sizes:
 7 7/8" x 10 1/2" Cat. X99997 **\$49.95**
 8 1/2" x 11" Cat. X99999 **\$49.95**

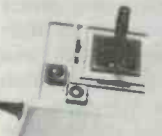

JOYSTICK FOR IBM
 Features Selectable "Spring centering" or "free floating" Electrical trim adjustments on both axis 360 degree cursor control
 Cat. C14205 **\$39.95**



INLINE SWITCHING BOX
 • 25 pin "D" plug to 25 pin "D" socket (RS232)
 • DIP switches allow easy switching of internal wiring.
 Cat. P00000 **\$32.95**



COMPUTER LEAD
 • 25 pin "D" plug to 25 pin "D" plug (RS232) DIP switches in each plug allow many combinations of internal wiring, making this a truly universal lead.
 • Mylar shielding against RF interference
 • Length 2 metres.
 Cat. P19031 **\$59.95**



COMPUTER LEADS
 We have a wide range of computer leads available, all at low prices!

APPLE:
 • Apple II, IIE, II+, with parallel interface card
 • Dual 10 pin (20 contacts) connector to Centronics 36 pin plug
 • Length 2.4 metres
 Cat. P19025 **\$29.95**

IBM
 • IBM PC, XT, and look alikes with 25 pin "D" plug on computer end to Centronics 36 pin plug on printer end.
 • Length 2.1 metres
 Cat. P19029 **\$44.95**

TANDY
 • For models II/116/16B/2000, with dual 17 pin female on computer end to Centronics 36 pin plug on printer end. (Equivalent to 25-1323)
 • Length 2.4 metres
 Cat. P19027 **\$34.95**

• For models III/44P, with 34 pin edge connector on computer end to Centronics 36 pin plug on the printer end. (Equivalent to 26-1401)
 • Length 2.4 metres
 Cat. P19028 **\$34.95**



TELEPHONE CURL CORD
 • U.S. plug to U.S. plug
 • Replacement hand set cord
 • Length 4.5 metres
 • Colours: cream, dark brown
 Cat. Y16022 **\$7.95**



TELEPHONE EXTENSION CABLE UNIT
 Allows 15 metres of telephone extension cable to be neatly wound into a portable storage container. The reel sits on a squared off base and the reel has a handle to wind cable back onto it after use. No tangles - no mess! Ideal for the workshop, around the house, office, pool etc.
 Cat. Y16013 **\$24.95**



IBM COMPATIBLE CARDS
NEW MOTHER BOARDS!
 XT compatible mother boards, 8 slots, room for 256K RAM
 Cat. X18020 **\$295**

GAMES ADAPTOR CARD
 Features 2 joystick ports
 Cat. X18019 **\$49**

MULTIFUNCTION CARD
 (384K RAM) Parallel, serial and game port. Plus battery backup clock.
 Cat. X18013 **\$329**

DISK CONTROLLER CARD
 Controls 2 slimline drives
 Cat. X18005 **\$89**

HIGH RESOLUTION MONOCHROME GRAPHICS CARD
 Give your IBM real graphics capability.
 Cat. X18007 **\$249**

512K RAM CARD
 Including RAM Cat. X18015 **\$299**
 Excluding RAM Cat. X18016 **\$129**



RS232 GENDER CHANGERS
 Saves modifying or replacing non-mating RS232 cables by changing from male to female to male. All 25 pins wired straight through
 Male to male Cat. X15650 **\$19.95**
 Female to female Cat. X15652 **\$19.95**

RS232 NULL MODEM ADAPTOR
 • Male to female connections
 • Pins 2 and 3 reversed
 • All 25 pins connected
 Cat. X15658 **\$22.95**



RS232 MINI PATCH BOX
 • Interface RS232 devices
 • With male to female 25 pin inputs
 • 25 leads with tinned end supplied
 • Complete with instructions
 Cat. X15654 **\$25.95**



RS232 SURGE PROTECTOR
 • Avoids costly damage from large voltage peaks caused by lightning or other power problems
 • Uses metal oxide varistors (M.O.V.) to suppress any voltage above 26V on pins 2, 3 and 7.
 • Will handle up to 1 Joule and 250A peak current
 Cat. X15660 **\$34.95**

WE HAVE A WIDE RANGE OF CABLE AND CONNECTORS!!

RAINBOW CABLE
 Suitable for IDC connections.
 Cat.No. Description \$metre
 W12714 28AWG 14W **\$1.80**
 W12716 28AWG 16W **\$1.80**
 W12720 28AWG 20W **\$2.20**
 W12726 28AWG 26W **\$2.90**
 W12734 28AWG 34W **\$3.60**
 W12740 28AWG 40W **\$4.40**



5 1/4" FLOPPY DISK SPECIALS!

XIDEX	1-9	10+
S/S/D/D	\$29.95	N.A.
Cat. X12401		
D/S/D/D	\$34.95	N.A.
Cat. X12410		
High Density	\$125	
Cat. X12520		

VERBATIM DATALIFE
 S/S/D/D \$27.95 \$26.95
 Cat. C12501
 D/S/D/D \$39.95 \$37.95
 Cat. C12504

VERBATIM VALULIFE
 S/S/D/D \$24.95 \$22.95
 Cat. C12421
 D/S/D/D \$31.95 \$29.95
 Cat. C12425

3 1/2" DISK SPECIALS
 Verbatim S/S Cat. C12372 \$75
 Xidex S/S Cat. C12600 \$65
 Xidex D/S Cat. C12602 \$89



DELUXE 5 1/4" DISK STORAGE UNIT
 Features:
 • Clear smoked plastic lid
 • Diskette fan display system elevates the disks for easy identification and access
 • Lockable lid (2 keys supplied)
 • High impact plastic base
 • 45 diskette capacity
 Cat. C16050 **Normally \$49.50**
NOW \$39.50



COMPUTER CASSETTES
 Quality 20 minute tapes
 Cat. D11141

1-9	10+	100+
\$1.00	\$0.90	\$0.80



RITRON (ZETA) DATASETTE
 For data loading and saving, the Ritron Datasette suits most home computers and features tape counter, monitor function for audio verification and slide control for output level.
 Cat. C14900 **\$24.95**

TELEPHONE ADAPTOR
 • Australian plug to U.S. socket
 • Length 10cm
 • Cream colour cable
 Cat. Y16026 **\$6.95**



IBM*
COMPATIBLES
from \$899*
 Incredible deals to suit everyone including special package deals!
 *256K RAM, single drive, graphics, disk controller and printer cards.



RITRON MULTI PURPOSE MODEM
 The RITRON Multi Purpose Modem has all the features you require.
 • CCITT V21 300 Baud Full duplex
 • CCITT V23 1200/75
 • Bell 103 300 Full duplex
 • Bell 202 1200 Half duplex
 • Auto answer, auto disconnect
 • Telecom Approval No. C843/771134
 Cat. X19103 **Normally \$399**
SPECIAL \$299



IC SPECIALS!

	1-9	10+	100+
4116	\$1.80	\$1.70	\$1.50
4164	\$2.95	\$2.75	\$2.50
2716	\$5.90	\$5.50	\$5.50
2732	\$6.25	\$5.95	\$5.50
2764	\$6.25	\$5.95	\$5.00
27128	\$7.00	\$6.50	\$6.25
6116	\$2.95	\$2.75	\$2.50
41256	\$7.00	\$6.50	\$6.00
6264	\$6.50	\$6.00	\$5.25

WORLD MODEM CHIP
 Cat. U21614 **Normally \$49.50**
Save \$20, NOW \$29.50



ROD IRVING ELECTRONICS
 425 High Street, NORTHCOTE, 3070 VICTORIA, AUSTRALIA
 Phone (03) 489 8866
 48 A Beckett St, MELBOURNE, 3000 VICTORIA, AUSTRALIA
 Ph. (03) 563 6151
 Mail Order and correspondence: P.O. Box 620, CLAYTON 3168
 TELEX: AA 151938

MAIL ORDER HOTLINE
 (03) 543 7877
 (2 lines)

POSTAGE RATES

\$1-\$9.99	\$2.00
\$10-\$24.99	\$3.00
\$25-\$49.99	\$4.00
\$50-\$99.99	\$5.00
\$100-\$199	\$7.50
\$200-\$499	\$10.00
\$500 plus	\$12.50

 This is for basic postage only. Comet Road freight, bulky and fragile items will be charged at different rates.
 Certified Post for orders over \$100 included "free"
 Registered Post for orders over \$200 included "free"
 All sales tax exempt orders and wholesale inquiries to RITRONICS WHOLESALE, 56 Renner Rd, Clayton Phone (03) 543 2166

 Errors and Omissions Excepted.

Book-sized 8 mm video camera/recorder

Sony has taken full advantage of the tiny 8 mm video cassette format in its newly released Video 8 product, the PAK-88, which centres around an ultra-small camera-recorder called the Handycam CCD-M8E and a new compact portable deck called the EV-C8.

The Handycam is the size of an average reading book and weighs just 1.4 kg (including battery and tape). This extreme portability has been achieved primarily through super-miniaturisation of the recording mechanism and circuitry.

The camera features a 3-position 'zoned focus' system (near, medium or far) which makes it as easy to use as an automatic stills camera. There's also a 2-position white balance for shooting either indoors (artificial light) or outdoors (sunlight). For the serious videophile this might be just a bit too easy, but it's certainly convenient for taking 'happy snappies'. Indeed, Sony calls this new system 'snap video'.

Like the larger CCD-V8E camera, the new CCD-M8E incorporates a 290,000-pixel CCD, which not only gives high resolution but also enables true colour fidelity (even under limited

lighting) and eliminates image lag or burn. Other features include high performance M&F (micro and fine) video heads, flying erase head for noise-free

picture transitions, built-in electret condenser microphone and optical viewfinder.

The EV-C8E portable video deck, weighing only 1.1 kg, allows continuous playback of approximately 150 minutes with a single battery. It has an LP/SP mode switch for extended recording time (90 minutes in

SP, 3 hours in LP), and has both an insert editing facility and a remote/edit controller connection.

Accessories included in the PAK-88 are a battery pack, an ac pack/battery charger, a battery charger adaptor, an rf adaptor, a 30-minute cassette and a carry-case.

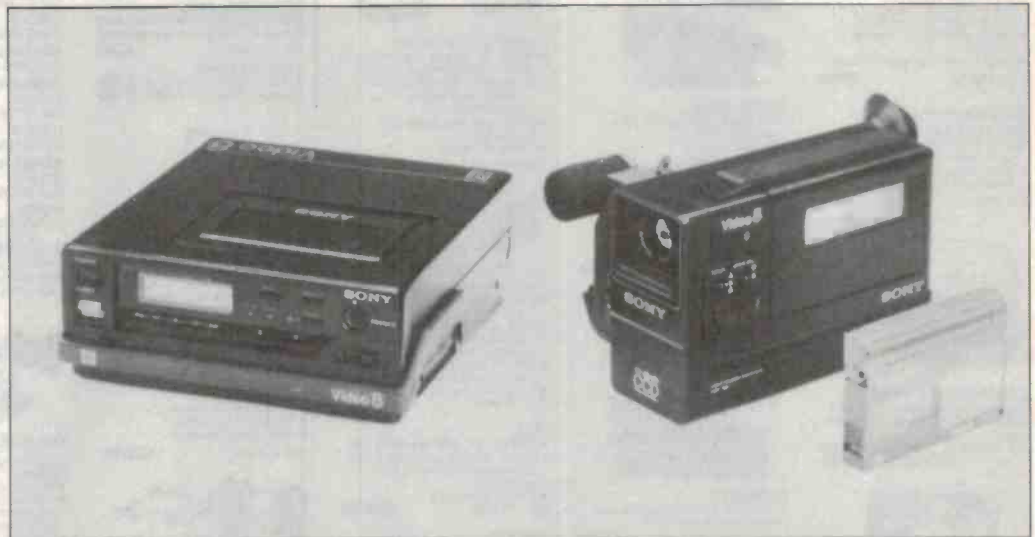

Akai's latest CD player

Akai's new compact disc player, the CD-A30, offers useful random playback features and high quality sound.

A 3-beam laser pick-up system is used for accurate and stable tracking, and the player is

microcomputer controlled to ensure fast and accurate command functions.

The CD-A30 has the capability of playing up to 36 tracks in any order. There is an MA-MB repeat play, so you can go back

to any place on a track and repeat that section as many times as you like. A manual search system is included, with two speeds. There's also a skip search to go to the end or beginning of the current track.

A subcode output jack for expanding visual capabilities of compact discs is on the back of the machine. This expansion, which uses special discs, will be available later this year. It involves connecting the subcode terminal to the video input of the TV so that at the same time as you listen to music, you can watch still pictures.

Other features of the CD-A30 include feather touch controls, index search system for finding index mark sections, 4-way liquid crystal display, disc centre support mechanism to securely hold discs during playback, and an insulated floating mechanism to protect from vibration and acoustic resonance during playback.

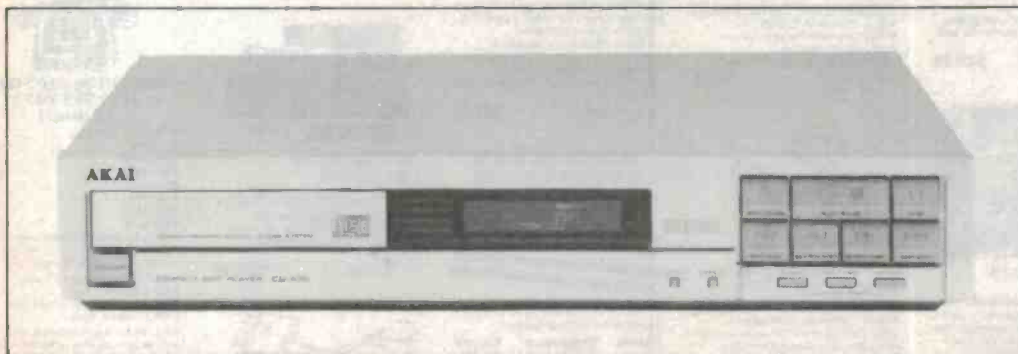

BRIEFS

LC-OFC audio cables

Hitachi's new linear crystal oxygen free copper cable (or LC-OFC for short) is available from Fred Hoe and Sons in Brisbane. The cable is made of high purity copper (99.99% minimum) and has fewer crystal boundaries than usual, resulting — we are told — in superior sound reproduction.

Colour coding for audio connectors

A range of 10 coloured boots for the Cannon AXR series of audio connectors is also available from Fred Hoe and Sons of Brisbane, to enable quick and easy identification of microphones and cable routing — provided you can remember the colour code!

NAD's new audio series

For the audiophile on a budget, NAD has introduced its 30 Series products, which supersede the popular 20 Series. The first three models to be released are the 1130 preamplifier, the 3130 integrated amplifier and the 4130 tuner.

Top CD from Pioneer

Pioneer's new CD Top is a lightweight, portable compact disc player that forms an integral part of a new sound system or can be used independently while walking, running or just lazing around. The system includes a four band equaliser, double

auto reverse cassette deck, high speed dubbing, FM stereo, 200 watt output and two-way detachable speakers.

Sanyo moves into VHS

Sanyo Australia has added several VHS video cassette recorder models to its existing range of Beta video products. The company also plans to launch an 8 mm format later this year.

New VHS buzzwords

An increased "white clip level" claimed to ensure a sharper picture is the latest technical innovation promised by the marketers of several VCR brands. Sanyo has it in its new VHR-1100, VHR-1300 and VHR-1500 models; Hagemeyer Australasia has it with its new JVC models, the HR-D250EA and HR-D565EA; and so does Akai with its latest VS 112 unit.

New JVC camera-recorder

A new JVC auto focus camera-recorder, the GR-C2EA, has been released by Hagemeyer Australasia. A more automated version of the GR-C1EA, it uses a VHS-C compact cassette and the whole unit weighs just 2.1 kg. Features include direct TV connection, fully adjustable electronic viewfinder and a host of useful accessories. A package including the camera, carrycase, battery charger, VHS cassette adaptor, battery, one cassette, rf unit, dubbing cable, carrying handle, shoulder frame and shoulder belt costs \$2799 RRP.

Spectrum loudspeakers

Hughes Communications has announced the release of three new loudspeaker models from Spectrum Loudspeakers.

Called simply Models One, Two and Three, the new loudspeakers retain many of the features of the company's previous series. The cabinet work has been redesigned and the cross-overs have been improved, in an attempt to flatten the overall frequency response and assist in

higher power handling capacity.

Prices range from the top of the line Model One, at \$1349 RRP, Model Two, which is a redesign of the SP7, at \$849, and the Model Three, derived from the 'Spectrum' bookshelf unit, selling for \$399.

Hughes Communications is the sole Australian distributor and will supply further information on request to (03)568-0612.

New professional recording format

Professional digital 'Prodiği' audio recorders from Otari Electric Company are being distributed in Australia by Klarion Enterprises, a member of the BCL group of companies. The tape machines conform to the newly established standard format jointly developed by Otari, Mitsubishi Electric Corporation and AEG Aktiengesellschaft (formerly AEG Telefunken).

"The development of digital technology puts a more sophisticated system at the hands of professional recordists," said Andrew Horman of Klarion. "It allows more flexibility with the

recording medium, allowing a wider range of possibilities and innovations for the engineer and the producer. This gives free rein to creative freedom, and results in better quality recordings."

Otari is a leading supplier of professional audio tape recorders and duplicators to the broadcast, recording and film industries around the world. Its Prodiği series includes a 32-channel version on 1 inch tape and a 23-channel version which has a timecode track and allows up to two hours of recording.

Speech transmission meter

Brüel & Kjær has developed a speech transmission meter, Type 3361, to enable objective assessment of the quality of an acoustic communication channel with respect to speech intelligibility.

Using the RASTI (rapid speech transmission index) method, the Type 3361 can measure a speech transmission index in less than 10 s. The RASTI method is currently being standardised by the IEC (Draft Publication 268, part 16).

The new speech transmission meter consists of two instruments: transmitter Type 4225 and receiver Type 4419. To make a measurement the transmitter is placed at the position normally occupied by the speaker and it sends out a special acoustic test signal from the built-in loudspeaker. The test signal consists of a pink noise carrier signal (octave bands centred at 500 Hz and 2 kHz) which is intensity modulated by a sum of low frequency sine waves.

The receiver is placed at the listening position and analyses the incoming signal, measuring the reduction in modulation

depth for each of the modulation frequencies.

This measured reduction in signal modulation is converted to an index of speech intelligibility. The resulting index, RASTI, varies between 0 and 1 and has been found to correlate well with the results of traditional subjective methods which use teams of speakers and listeners.

Applications for the new meter include the assessment of speech intelligibility in auditoria and lecture rooms with or without speech reinforcement systems. The speed of measurement of the Type 3361 permits a large number of measurements to be made from which intelligibility contours can be drawn. (Such detailed analysis would be very time-consuming and costly using the traditional methods.)

In addition to the RASTI-value, the Type 3361 measures the speech transmission index for each octave band of the carrier signal and the modulation reduction factor for each modulation frequency (there are nine modulation frequencies between 0.7 Hz and 11.2 Hz).

CLASSY CAR CD PLAYER

— Yamaha YCD-1000 car CD player

Yamaha's new car CD player features a clever cartridge format that enables first rate musical performance. The unit's not cheap, but for the dedicated listener it's packed with value.

Louis Challis



YAMAHA YCD-1000 CAR CD PLAYER

Dimensions:	
Main Unit:	180 mm (wide) x 50 mm (high) x 195 mm (deep) (155 mm from escutcheon to rear of unit)
Power Unit	140 mm (wide) x 35 mm (high) x 50 mm (deep)
Weight:	1.55 kg (310 g)
Manufacturer:	Nippon Gakki, Hamamatsu, Japan
RRP:	\$849

WHEN I WAS first shown the Yamaha CD cartridge system in Hamamatsu just over a year ago, Nippon Gakki (otherwise known as Yamaha) had already developed but had not yet released the YCD-1000 car CD player. Although the company released the unit in America late in 1985, I had to wait more than a year before I was given the chance to put one through its paces.

The real size of the market for car CD players is somewhat nebulous at present, and marked by a reluctance on the part of new car designers to provide appropriate space for installing a CD player in dashboards. A car radio is all right, a combined cassette player/radio is even better, but the 'nasty' CD player requires a supplementary DIN sized slot for which they have previously given no thought and display little enthusiasm. As a consequence, Yamaha (and anyone else for that matter who even contemplates manufacturing an automotive CD player) has to be looking at a very much smaller market with entrenched buyer resistance.

The Yamaha people, of course, have given quite a good deal more thought to these market-resistance forces than have many of their worthy competitors. The problem they considered to be the most significant was that created by the 'handleability' of the disc in the automotive envi-

ronment. Put in simple terms, the driver of a vehicle cannot and should not take his or her eyes off the road in order to pick up a disc by its edges, in the way you ought to handle conventional LPs or CD discs.

Yamaha's solution was to develop a natty new cartridge format which provides positive (but not perfect) protection for the CD discs which you load as required before departing in your automobile. The cartridge has a series of internal shutters which are opened up by the player in order for the laser pick-up to scan the disc and play its music. As a consequence, each YCD-1000 comes complete with a packet of five cartridges (enough to get you started) and more are readily procurable at \$50 RRP for each additional five-pack.

The thrust of Yamaha's approach was, and is, to provide an additional 'encapsulation package' which protects the valuable discs and allows you to poke the cartridge away into the slot in much the same way as

you would handle a compact (tape) cassette. The idea obviously has a lot of merit and was not intended to result in any incompatibility of the basic CD system, but rather to avoid a problem before it became one.

Design and appearance

The cartridge may appear relatively large (although it's not) but because of its lateral dimension it tends to be a trifle awkward to open, particularly for a person with small hands. Each of the cartridges is carefully 'polarised' so that it can only be loaded one way — the correct way. This is achieved through the use of a side slot mechanism supplemented by a little lever which opens the bottom flap for the laser pick-up to scan the disc.

The lid of the cartridge is moulded from clear plastic so that you can readily identify the disc that it contains. Yamaha also provides a series of supplementary self-adhesive labels which are intended to be stuck on the back (ie, the exposed edge) of each cartridge. These can be typed or written on with the appropriate disc description.

I believe the second problem Yamaha had to cope with was far more difficult to resolve than the first. This required the company to design an impact absorbing isolation system which can cope with both the low frequency and high frequency vibration generated by a vehicle passing over a bad road (quite apart from the good roads).

This is an extremely difficult task, given the variability of roads, the variability of vehicles and the speed and manner in which a vehicle may be driven. Yamaha's solution was to design a two-stage rubber isolation system which is very effective from 0.5 Hz to 15 Hz and even better in the range 25 Hz to beyond 100 Hz. Not only does the isolation system work well, but more importantly, it doesn't take up an unacceptable amount of space inside the player.

The third feature which Yamaha incorporated was a double resolution digital filter operating at twice the sampling frequency so that harmonic and intermodulation distortion products are lower than normal and comparable with the better CD players on the market. This of course utilises a series of three large scale integrated chips which Yamaha developed for use in its complete range of CD players.

The fourth problem which had to be tackled was the nasty one of potential thermal damage from excessive temperatures which almost certainly develop under the dashboard of dark cars in tropical heatwave conditions.

Having solved all of these problems without impinging upon the shape, size and practicality of the unit, Yamaha was reasonably satisfied that it could market this unit anywhere in the world without qualms and certainly without embarrassment.

One potential problem which intrigues

me, and for which I don't yet have any definitive information, is how well the unit copes with the dust conditions in an Australian off-road vehicle or on some of our better known 'highways', like the Bridsville Track. (If you happen to install one and subject it to such agonies, would you please tell me the results.)

The output of the player is at line level, ie, 2 volts peak into 1 kohm so that a supplementary external amplifier is essential. As an alternative, a Yamaha car stereo receiver (YCT-450 or equivalent) equipped with appropriate sockets may also be used. Obviously, other brands of car receivers may be similarly equipped and might be used, however at present few of these are suitable.

The front escutcheon which is designed to stick out from the dashboard of the vehicle is neat and attractively moulded in dark grey plastic. White silk-screened lettering for annotation of controls and knobs is provided in the central band between the disc well and the row of controls, which are located immediately beneath. The lettering, although clear, is nonetheless relatively small and some of the words are likely to be difficult to read, except for a person relatively close to the unit.

At the top of the unit is the recessed slot into which the cartridge is inserted. This has a simply hinged lid which closes after the cartridge is loaded to provide additional

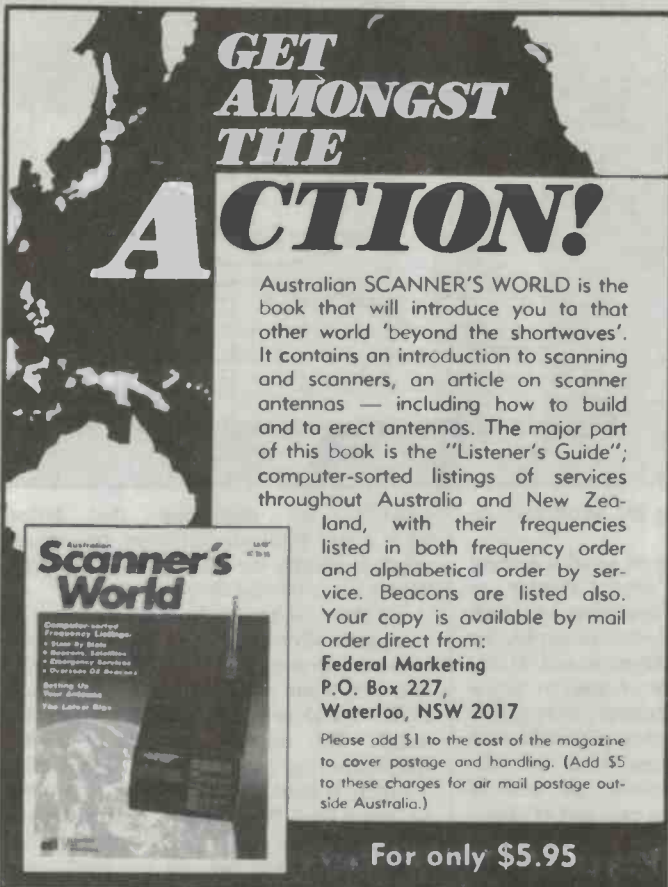

GET AMONGST THE ACTION!

Australian SCANNER'S WORLD is the book that will introduce you to that other world 'beyond the shortwaves'. It contains an introduction to scanning and scanners, an article on scanner antennas — including how to build and to erect antennas. The major part of this book is the "Listener's Guide"; computer-sorted listings of services throughout Australia and New Zealand, with their frequencies listed in both frequency order and alphabetical order by service. Beacons are listed also. Your copy is available by mail order direct from:

Federal Marketing
P.O. Box 227,
Waterloo, NSW 2017

Please add \$1 to the cost of the magazine to cover postage and handling. (Add \$5 to these charges for air mail postage outside Australia.)

For only \$5.95



Sophisticated Sound

"State of the Art" sound equipment at Sydney's cheapest prices. Choose the components to make your ultimate sound system.

Strathfield Car Radios

LET'S GO

20 Albert Road, Strathfield
275 Church Street, Parramatta
66 Burelli Street, Wollongong

SOUND REVIEW

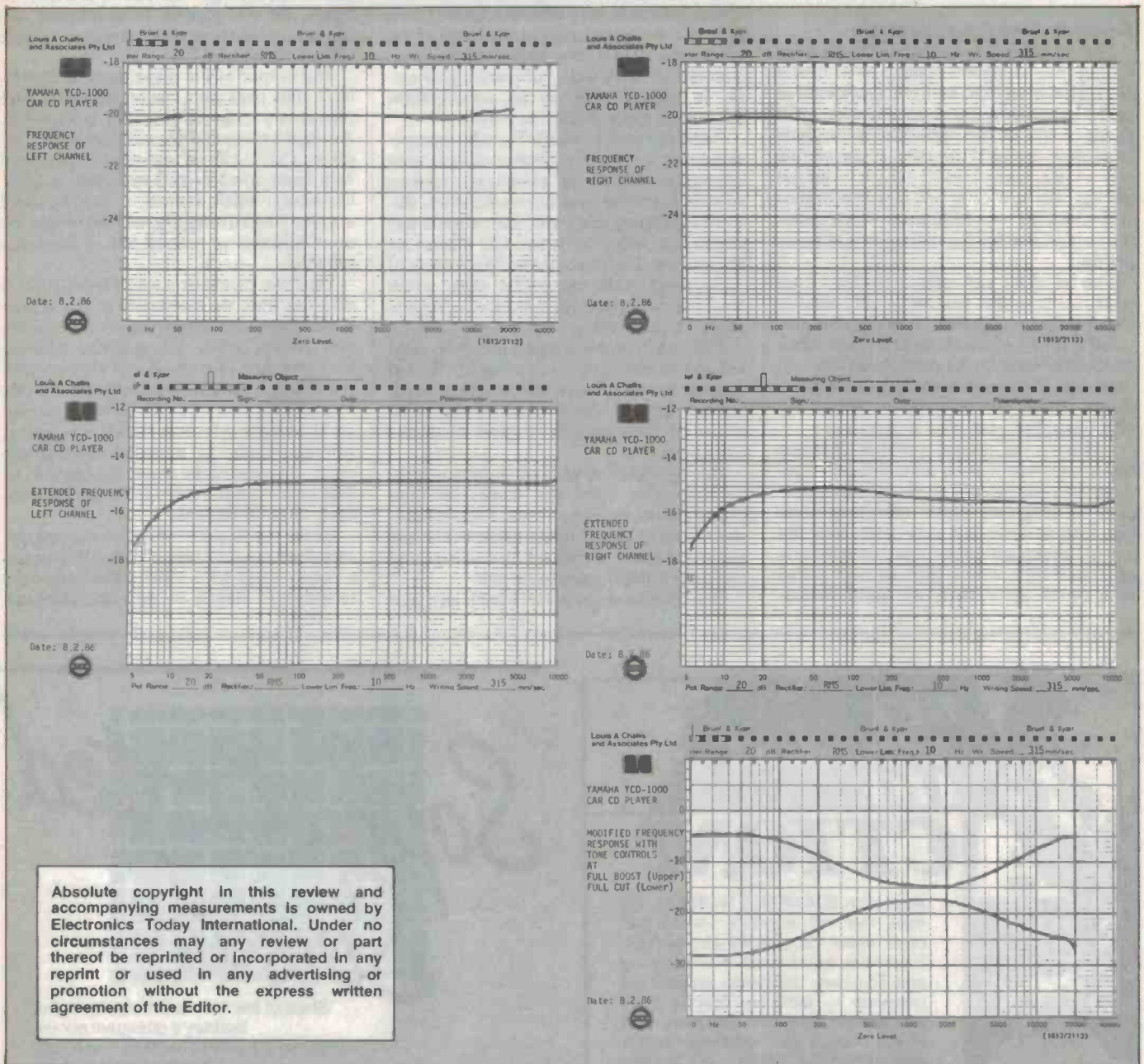

Absolute copyright in this review and accompanying measurements is owned by Electronics Today International. Under no circumstances may any review or part thereof be reprinted or incorporated in any reprint or used in any advertising or promotion without the express written agreement of the Editor.

protection. After the initial 'push', the internal drive mechanism picks up the cartridge and does the rest. With the lid closed and the power off, you have no way of knowing if a disc is loaded.

To start the unit playing, all you have to do is lightly touch the front of the VOLUME control, likewise if you wish to stop the music. Concentrically mounted behind the volume control is a BALANCE control, while immediately to the right are the separate BASS and TREBLE controls, which are recessed almost flush with the front panel. A light touch on either of these allows them to spring forward, where you are able to provide the required amount of ad-

justment before pushing the knob back to its previous position.

In the middle of the front panel is a small rear illuminated liquid crystal display on which the primary information of track number and minutes and seconds of play for that track is clearly displayed in red. (I believe that a softer shade of blue or green would probably have been more attractive!)

The display also provides information on whether the unit has been set in the REPEAT mode, SCAN mode, as well as whether the unit has been exposed to excessive heat. Under such conditions, the microprocessor initiates a protective lock-out and switches itself off. In fact, it almost displays

'HELP!' by displaying the letters 'H H H H'. If this should occur, you are advised to switch the unit off and wait patiently for it to cool down.

On the right hand side of the display is an elongated silver rocker switch which provides the bi-directional MUSIC SEARCH function, while adjacent to this is the FAST FORWARD and FAST REWIND rocker switch. This initially operates at a slow speed allowing you to listen to the recorded content. If held continuously in that mode for more than 10 seconds it speeds up, still allowing you to detect part of the recorded content but obviously not as clearly as it does at the slower speed.

MEASURED PERFORMANCE OF YAMAHA CAR CD PLAYER WITH

CARTRIDGE SYSTEM

MODEL NO. YCD-1000

SERIAL NO. 01888

1. **FREQUENCY RESPONSE** 20 Hz to 20 kHz ± 0.3 dB
3 Hz to 22.03 kHz ± 2 dB

2. **LINEARITY** @ 1kHz

NOMINAL LEVEL	L. OUTPUT	R. OUTPUT
0dB	0.0	0.0
-1.0	-1.0	-1.0
-3.0	-3.0	-3.0
-6.0	-6.0	-6.0
-10.0	-10.0	-10.0
-20.0	-20.1	-20.0
-30.0	-30.0	-29.9
-40.0	-40.0	-39.9
-50.0	-50.0	-49.9
-60.0	-60.0	-59.9
-70.0	-69.9	-69.8
-80.0	-79.5	-79.5
-90.0	-89.2	-88.3

3. **CHANNEL SEPARATION**

FREQUENCY	RIGHT INTO LEFT dB	LEFT INTO RIGHT dB
100 Hz	78.4	79.5
1 kHz	76.4	69.0
10 kHz	61.7	66.8
20 kHz	59.0	60.4

4. **DISTORTION** (@ 1kHz)

Level	2nd	3rd	4th	5th	THD%
0	63.6	71.2	6.5	82.4	0.074
-1.0	64.4	71.9	74.1	86.6	0.066
-3.0	62.9	66.9	74.0	82.2	0.087
-6.0	64.4	78.5	80.2	73.5	0.066
-10	61.3	85.5	79.7	77.2	0.088
-20	63.2	72.6	73.9	79.0	0.077
-30	62.7	76.7	80.6	77.7	0.076
-40	73.5	69.6	75.6	82.9	0.043
-50	69.5	68.2	66.3	58.7	0.14
-60	-	56.5	55.6	49.3	0.41
-70	47.7	39.1	-	-	1.18
-80	-	29.6	39.1	28.3	5.19
-90	21.5	27.7	33.1	14.9	20.4

Level	2nd	3rd	4th	5th	THD%
@ 100 Hz	61.5	66.7	76.5	74.2	0.099
-20	63.7	70.9	72.6	80.6	0.076
-40	71.0	70.6	79.7	75.5	0.045
-60	58.9	60.2	58.2	52.6	0.30

Level	2nd	3rd	4th	5th	THD%
@ 6.3 kHz	55.1	58.2	75.6	-	0.21

5. **EMPHASIS**

Frequency	Recorded Level	Output Level (L)	Output Level (R)
1 kHz	-0.37 dB	-0.4	-0.4
3 kHz	-4.53 dB	-4.3	-4.3
16 kHz	-9.04 dB	-9.5	-9.4

6. **SIGNAL TO NOISE RATIO**

Without Emphasis	85.3 (Lin)	92.5 dB(A)
With Emphasis	94.0 (Lin)	97.5 dB(A)

7. **FREQUENCY ACCURACY**

19.999 kHz -1.5 Hz for 20 kHz test signal

8. **SQUARE WAVE RESPONSE**

100 Hz	Square wave	See Photo
1 kHz	Square wave	See Photo

9. **IMPULSE TEST** See Photo

DIRTY RECORD TEST

Interruption in Information Layer	Black Dot at Read out Side
400 micrometer ; Passed	300 micrometer ; Small glitches
500 micrometer ; Small glitches	500 micrometer ; Passed
600 micrometer ; Small glitches	600 micrometer ; Passed
700 micrometer ; More small glitches	800 micrometer ; Small glitches
800 micrometer ; More small glitches	
900 micrometer ; Even more glitches	

BLACK STRIPE TEST - passed

VIBRATION TEST

Acceleration level 30g' @ 2 Hz on each of three orthogonal axes	Passed
Acceleration level 30g' @ 100 Hz on each of three orthogonal axes	Passed

Response curves

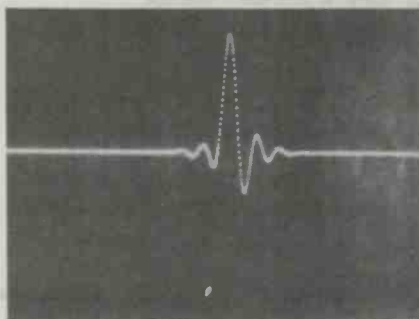

Impulse wave

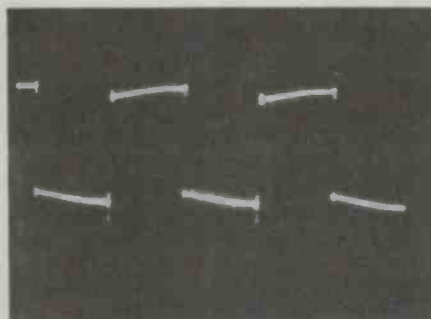

Square wave at 100 Hz

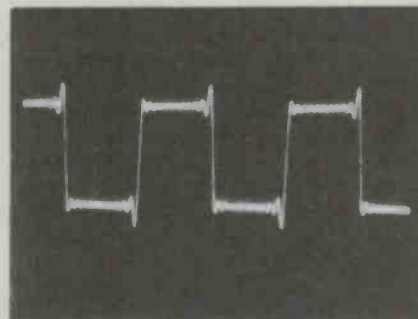

Square wave at 1 kHz

Two small switches are provided near the base of the escutcheon, the MUSIC SCAN, which sets the player into a scanning mode to play the first 10 seconds of each track, and the adjacent REPEAT switch, which when activated, causes the disc to replay over and over again until such time as the STOP button is touched.

The last control is the EJECT button at the extreme right hand corner, which unloads the internal cartridge and allows you to remove it or replace it at will.

A series of leads extends from the rear panel of the unit. Two short leads terminating in white and red RCA coaxial sockets together with a pair of additional wires ex-

tend from the left hand side, while a mains power lead cable terminated in a multi-pin socket extends from the right hand side. A supplementary mains lead with fuse box and extended terminal socket is provided for positioning under the dashboard of the vehicle to facilitate connection to the normal battery supply and supplementary dashboard night-time illumination supplies.

Objective testing

The objective testing of the unit soon revealed that Yamaha has extended its research and development well beyond what I was shown at Hamamatsu a little more than a year ago.

The first and most obvious result of that research has been a tightening up of the frequency response capabilities provided by the well developed special purpose large scale integrated circuits which have enabled Yamaha to stay in the forefront of CD sales.

The frequency response at 0 dB was particularly good as the high frequency response has apparently been tailored to extend both lower and, it would appear, possibly higher than that provided by some of its domestic CD players. The measured responses of the right and left channels were different, the left channel being somewhat flatter than the right as the level recordings

SOUND REVIEW

clearly show. The left channel is ± 0.3 dB from 20 Hz to 20 kHz while the right channel is ± 0.2 dB from 20 Hz to 20 kHz. The measured responses of both channels are down by 1 dB at 10 Hz and by 2 dB at 5 Hz. These linearities are comparable with other current generation CD players and unquestionably 'far too good' for an automotive listening environment, where it might have been even better to have had a restricted bandwidth at both ends of the spectrum.

The tone controls provide a genuine ± 10 dB at 100 Hz and ± 8 dB at 10 kHz. The response above and below these frequencies remains virtually flat thereafter, which I believe is essential. The high frequency boost is good all the way out to 20 kHz at which point there is no real justification or need for any further boost or cut.

The measured linearity provided by the digital-to-analogue conversion circuitry is extremely good and although I was able to detect the first minute traces of non-linearity at -30 dB (which is rather unusual), there was no further significant change in that position until the test signals reached the -70 dB point (which I regard as being extremely good). At -80 dB the non-linearity was only 0.5 dB, which is excellent, while at -90 dB the measured non-linearity (deviation) is the best result I have yet seen.

The measured channel separation figures are lower than I have come to expect from residential-type CD players, but the separations are still so far in advance of what you need, let alone what you can hear, that they don't upset the equation one little bit.

The measurements of total harmonic distortion at 1 kHz are again somewhat different from those provided by other residential-type CD players that I have evaluated over the last three years. Surprisingly, between 0 dB and -30 dB there is an almost constant harmonic distortion level, which only starts to vary significantly (and then by only half an order of magnitude) at -50 dB. Thereafter, the distortion starts to climb fairly rapidly, but is still quite acceptable, even when the signals drop down to -80 dB (where it's 5%) and finally to -90 dB, where the distortion is up to 20% (which you will never hear).

The distortion figures measured at 100 Hz and at 6.3 kHz are still very good; this is one CD player with which I can find very little fault in this respect. The signal-to-noise performance is excellent, being better than 94 dB (with emphasis) and again much better than you will ever need in an automobile, boat or any other form of transportation that I can think of. The frequency accuracy is good at -1.5 Hz relative to the 20 kHz test signal and it remained for the evaluation of the 'dirty record' test material to show any significant difference between this and any other residential-type CD players.

The 'interruption in information layer' test provided some audible 'glitches' which the average listener would not begin to detect in a car. As the size of the gap grew bigger, the audibility of those glitches increased, but never to the point where I regarded them as being unacceptable. The 'black dot' test provided similar 'glitches' which were much more audible, but nonetheless *did not* result in mistracking or other nasty 'skipping' problems that many recently reviewed CD players have exhibited.

The last examinations to which we submitted the YCD-1000 were a series of vibration tests at increasing levels of severity at test frequencies of 2 Hz and 100 Hz. Much to my surprise, these tests revealed that the YCD-1000 copes with peak acceleration levels of up to 30 'g' in any of the three primary axes before the three-beam laser pick-up or its rubber suspension assembly mistrack on either normal or special test discs.

I found this particular characteristic rather surprising as that level of vibration would only be created in a vehicle with relatively hard suspension travelling on a badly corrugated road or on a road with very bad pot holes. To expect that any CD player would be able to cope with such vibration levels would not only indicate a degree of optimism, but would mean subjecting oneself to extreme discomfort. (I, for one, try to avoid such roads like the plague, because they normally result in other more disconcerting problems with the vehicle at some later stage.)

Subjective testing

I evaluated the YCD-1000 with a wide range of test material including a new and truly vibrant Denon disc of Mendelssohn's 'A Midsummer Night's Dream' with Peter Maag conducting the Tokyo Metropolitan Symphony Orchestra (33C37-7564), which is magnificent, and another new disc of the Mannheim Steamroller's 'Christmas' from American Gramophone AGCD-1984, which provides a new and modern twist to Christmas carols. The last disc I listened to was Don Dorsey on his digital synthesiser in 'Bachbusters' (Telarc CD80123), which sold like 'hot cakes' at the Las Vegas CES.

All the discs sounded superb and convinced me that the musical performance of the YCD-1000 has not suffered one little bit from being configured so as to meet automotive requirements.

At a selling price of \$849 RRP, the YCD-1000 is not cheap and this will unquestionably limit its market. However, if I owned a large motor yacht, sailing yacht or expensive limousine I would not hesitate to fit one immediately. This is one piece of consumer electronics that you 'well-heeled' ladies and gentlemen should be planning to install right now!

MUSITRONICS

PROFESSIONAL SOUND & LIGHTING

DISTRIBUTORS FOR:

ETONE

Loudspeakers

RENKUS-HEINZ

Smart Speaker
Systems

RCF

Cone & Compression
Drivers

ZPE

Mosfet Amplifiers

TELDAT

Telecom Approved
Modems

NJD

Lighting
Controllers

CITRONIC

Professional Disco
Mixers, Consoles
& Amplifiers

COMPUTERS

High Quality
IBM & Apple
Workalikes

QUANTITY & WHOLESALE ORDERS ONLY

MUSITRONICS

19 ASHFORD RD.,
KESWICK, S.A. 5035
PH.: (08) 297-8932
(08) 297-9777

TLX: AA88765-AD312

MUSITRONICS

VIATEL 82978320

AUSBEG MUSITRONICS

SOUND MOVE FOR CARS

— Sony XR-A740 FM/AM car stereo receiver/cassette player

The Sony Corporation is taking the issue of AM stereo very seriously. With one of the best (and cheapest) hi-fi stereo AM/FM tuners already on the local market (model STJ X220A, RRP \$239), the company is well placed to make further market in-roads with an AM/FM stereo car cassette receiver.

Louis Challis

SONY XR-A740 FM/AM CAR STEREO RECEIVER CASSETTE PLAYER

Dimensions: 178 mm (wide) x 50 mm (high) x 165 mm (deep) — 135 mm deep behind dashboard

Weight: 1.4 kg

Manufacturer: Sony Corporation, Tokyo, Japan

RRP: \$499



THE RECENT RELEASE of the XR-A740 provides Sony with a product which is, to aptly use its words, 'a moving sound experience'. Sony has picked the middle priced of three models developed for world sales as the most appropriate unit to market in Australasia. This particular model incorporates a series of unusual design and ergonomic features which have been extensively researched and confirmed as being preferred by most drivers when operating in a 'tactile' mode.

The one feature that I consider as being the most important is, of course, the incorporation of an AM stereo tuner circuit. The bandwidth of this circuit is fortuitously almost as good as that provided by the STJ X220A. The unit also provides an excellent FM stereo receiver and an exceptionally good cassette player, about which I will have even more to say later.

Design and appearance

The Sony designers faced a particularly difficult problem when they came to consider the many options and choices for the operational controls that could be incorporated on to the front panel of this unit. The majority of manufacturer's packages now conform rigidly to the DIN size specification, which allows any brand of radio to be installed or replaced in the front dashboard slot of the vehicle. Obviously, with that space restriction and the multiplicity of new controls and extra displays now possible, designers either have a field day or one great big headache.

The final front panel layout has discarded the conventional tuning dial and has replaced it with a smaller, more reliable and more space efficient liquid crystal display. The dimensions of this display neatly match the cassette well slot on the front panel into

which the cassettes are then loaded 'end-on'.

Immediately below the display are four soft-touch pushbuttons — two small ones flanking two larger ones. The first of these buttons controls the LCD display, so that you can display the time, as well as the station frequency and information as to which of the pre-set AM or FM channels has been selected. It also tells you whether the signal is stereo or mono and whether you have selected local or long range (DX) reception. The two middle buttons are labelled MANUAL, with a minus and plus sign at each end, as well as with an 'H' and a 'M'. These are arranged in a 'rocker' configuration for manually adjusting the station tuning up or down, as well as for setting the time in conjunction with the adjacent MEMORY/TIME SET mode switch.

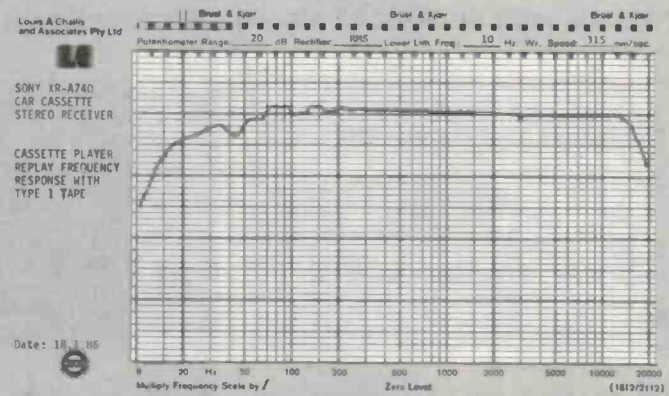
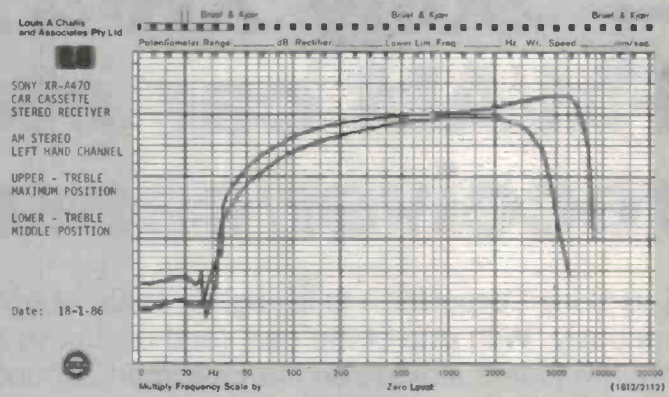
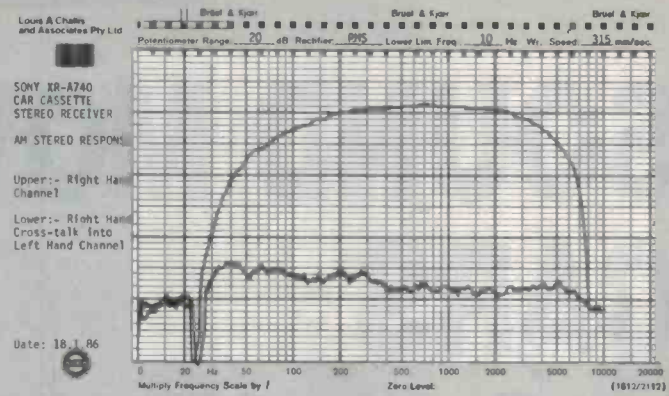
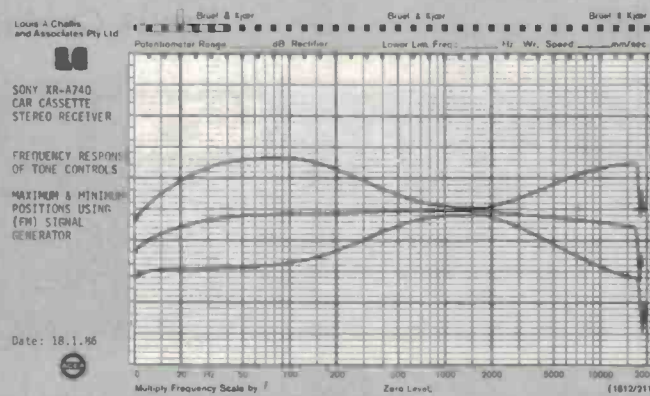
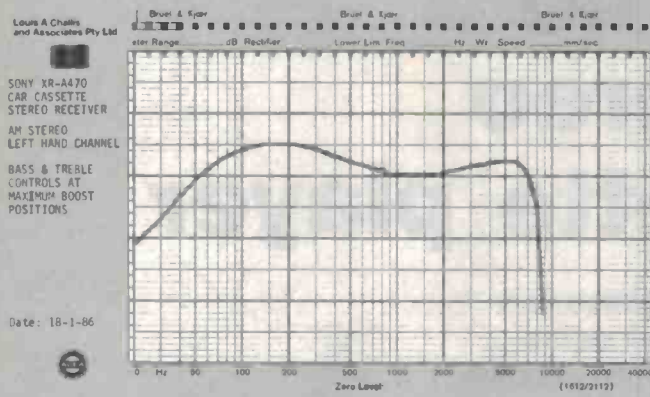
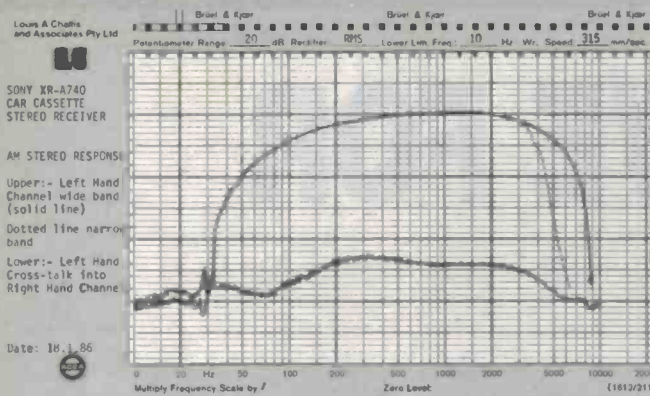

At the extreme left hand side of the front panel is a large dual concentric rotary control. The most prominent (and outermost) knob has a central green dot and controls the VOLUME. Following the single depression of this control, it then also doubles as a BALANCE control. Behind this control is another concentrically mounted FADER control. Behind this, yet again, on the left hand side of the other rotary controls is a small three position tab switch. This provides the selection for normal AM stereo (N), wideband stereo and mono selection, respectively. These controls and those below are a little too crowded for comfort and are the only feature of the unit with which I was not fully at ease.

On the bottom left hand corner are two

small rotary control knobs which are mounted flush with the surface and which, when lightly touched, pop out another 15 mm to provide a control which is neatly accessible for your fingers. These controls both have centre indents and provide excellent control of BASS and TREBLE respectively. To the right, and at the top of the fascia, is a bright blue STOP/EJECT button which you press once to stop the tape transport or press 'twice' to eject the cassette (if one is loaded).

Below this is a 'soft key' loudness control button. Two additional buttons, each with a small rear illuminated LED, are provided for band selection (AM or FM) and for scanning. The SCAN button enables you to automatically scan up or down for stations

which have not been previously pre-set in the internal memory bank.

At the top right hand side of the front panel are two grey switches, one large and the other small. The larger is a rocker switch and is labelled REWIND and FAST FORWARD at the two opposite ends. This switch also has small LEDs recessed behind the switch face. The switch is also labelled AMS and if pressed once, at either end, will initiate the automatic music search mode in the forward or reverse direction so that the cassette player searches for the start of a track which it then proceeds to play. If pressed twice the tape transport goes into the normal fast forward or reverse mode. To deactivate these controls, you either have to touch the STOP/EJECT button or

Louis A Chellis and Associates Pty Ltd

SONY XR-A740 CAR CASSETTE STEREO RECEIVER

FM FREQUENCY RESPONSE
Upper:- Right Hand Channel
Lower:- Right Hand Cross-talk into Left Hand Channel

Date: 18.1.86

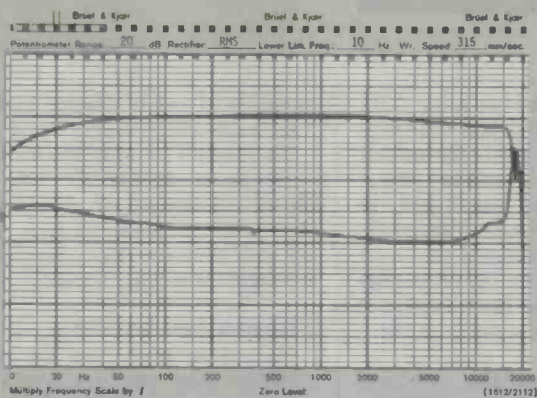

Louis A Chellis and Associates Pty Ltd

SONY XR-A740 CAR CASSETTE STEREO RECEIVER

FM FREQUENCY RESPONSE
Upper:- Left Hand Channel
Lower:- Left Hand Cross-talk into Right Hand Channel

Date: 18.1.86

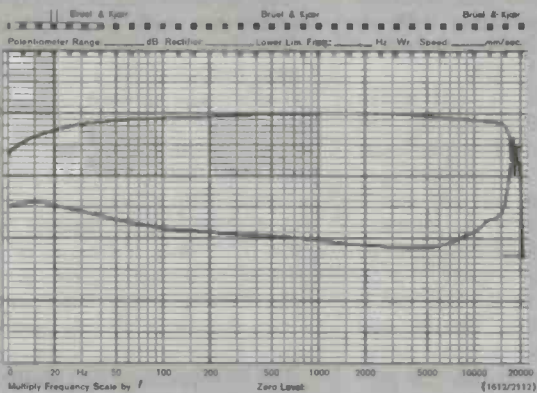

Louis A Chellis and Associates Pty Ltd

SONY XR-A740 CAR CASSETTE STEREO RECEIVER

CASSETTE PLAYER REPLAY FREQUENCY RESPONSE WITH TYPE IV METAL TAPE @ 20VU

Date: 18.1.86

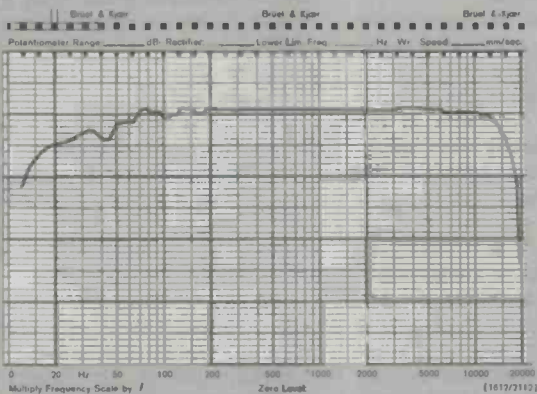

the PLAY/DIR, which initiates play or change of play direction.

Immediately below these two buttons are six memory buttons of reasonable size, which are used to memorise six AM and six FM station frequencies when used in conjunction with the memory/time set button. Two other small buttons are provided for FM/MONO and for selection of METAL/LOCAL. The latter of these two switches provides for correct equalisation when replaying a metal tape and for a lower rf stage sensitivity suitable for local station reception.

The rear panel of the receiver is a heavy diecast frame providing the heatsink for the power output stage which has a 'hefty' 2 x 20 watt capability. A conventional aerial

socket lead extends through one end and a mass of wires for speakers and power supply connections is at the other end.

With the cover of the receiver removed, you can quickly perceive the difficulties that Sony (and all other manufacturers) face in fitting the amount of electronics required by a car cassette player into such a small space. With the centre area already occupied by the cassette drive mechanism, the only space that is left is that filled by the large mother board at the base, two vertical back-to-back printed circuit boards at the rear, the vertical radio frequency and IF stage circuit board on one side and a series of small audio frequency stage printed boards, each with plug and socket connections provided on the other side. Even a sizable proportion

MEASURED PERFORMANCE OF SONY XR-A740

CASSETTE CAR STEREO WITH FM/AM ELECTRONIC TUNER

Serial number: 15

REPLAY FREQUENCY RESPONSE AT -20VU:

(AS 2680 Clause 2.2.3.1)

Tape	Dolby	Lower - 3dB Point	Max. Point & Frequency	Upper - 3dB Point
Type I	OUT	30 Hz	+1.0 @ 100 Hz	16 kHz
Type IV	OUT	30 Hz	NIL	15 kHz

SPEED ACCURACY: +0.4% with TDK Reference tape

(AS 2680 Clause 2.2.1)

WOW AND FLUTTER:

(AS 2680 Clause 2.2.2)

WOW:	Average	0.2% peak to peak
FLUTTER:	Unweighted	0.15% RMS
	Weighted	0.1% RMS

HARMONIC DISTORTION: (including AM generator distortion) (at rated output 11 watts into 14 ohms)

Tape: Sony AHF at 4 watts amplifier output

OVU:	2nd	3rd	4th	5th	TOTAL	T.H.D.
	-27.9	-51.7	-43.2	-61.7	-27.2	4.3
	-32.0	-54.1	-50.8	-	-31.9	2.6
					-46.9	0.45
						%

with 1 watt output

-6VU:	2nd	3rd	4th	5th	TOTAL	T.H.D.
	-34.9	-61.1	-48.8	-	-34.8	1.8
	-36.5	-57.4	-59.1	-	-36.0	1.5
					-51.0	0.29
						%

9 dB boost and 8 dB cut at 100 Hz
9 dB boost and 7 dB cut at 10 kHz

EQUALISATION IS in accordance with IEC 268-3B

DYNAMIC RANGE:

Tape:	Sony AHF (Type I)	55 dB(Lin)	60 dB(A)
	TDK Metal (Type IV)	59 dB(Lin)	64 dB(A)

FM TUNER:

Frequency Range: 87.5 - 107.9 MHz
Usable Sensitivity: (40 kHz deviation)
MONO for signal to noise
STEREO for signal to noise

26 dB	11 dBf
46 dB	19 dBf

AM TUNER:

Frequency Range: 531 - 1611 kHz
Usable Sensitivity: 21 microvolts for 20 dB signal to noise ratio on Mono signal

Signal to Noise Ratio @ 1 mV input 49 dB

Bandwidth:	Narrow Band Mode	Wide Band Mode	(Treble boost)
stereo	3.2 kHz	5.0 kHz	7.5 kHz
mono	3.2 kHz	5.2 kHz	7.6 kHz

Channel Separation:	Stereo	Right to left	30 dB
		Left to right	24 dB

of the remaining space that would normally have been allocated for the audio frequency stage has been purloined for the cassette motor drive.

The receiver and cassette recorder design makes use of a large number of new special purpose ICs, many of which are not of Sony manufacture. I became aware that a significant number of other components used within the cassette drive and other sections have been manufactured by other major Japanese producers, who have developed special expertise which Sony has not been slow in accepting.

The mechanical components within the unit are extremely well engineered, with an emphasis on ruggedness and reliability. Although plastic components are used, they

have been primarily restricted to a limited number of gear drives and slide components. The rest of the primary elements are steel or stainless steel. The printed circuit boards are all phenolic based rather than glass fibre, as might be expected, although without exception they are fabricated to high standards and comprehensively designated on the component side. The inter-board wiring, although neat and well executed, is primarily discrete rather than in the form of ribbon cables. In most cases, this wiring is connected to plugs which are then inserted into board-mounted sockets. The ventilation for the unit has been carefully executed by means of slots at the rear in both the bottom and top of the chassis covers. The component density indicates that this unit would be likely to operate at high temperatures.

The overall impression I gained is that the Sony designers have had to 'shoe-horn' the boards and incorporate the components with more than a bit of ingenuity, as well as considerable TLC (tender loving care).

Objective testing

The objective testing of the XR-A740 provided quite a few pleasant surprises. The cassette player provides a replay linearity which is positively outstanding. The frequency response with Type I tape is ± 3 dB from 45 Hz to 16.5 kHz while the metal tape response is nearly, but not quite as good, being 45 Hz to 15 kHz. The differences between these two results does not reflect a deficiency in the cassette player, but rather the azimuth alignment differences between the two calibration replay tapes.

The shapes of the measured frequency response curves are extremely smooth and considerably better than I would have expected to see. The high frequency response is exemplary and even the low frequency response is still less than 6 dB down at 20 Hz. The signal-to-noise performance of the cassette player is 55 dB with Type I tape and better than 59 dB with metal tape. The deck does not incorporate Dolby noise reduction and consequently cannot achieve the order of performance that some of the other more expensive 'Dolbyised' decks are capable of providing.

The measured wow figure is only 0.2% peak-to-peak, while the unweighted and weighted flutters are extremely good at 0.15% and 0.1% rms respectively. The absolute speed accuracy is also particularly good at +0.4%, and this particular deck section exhibits performance figures which are slightly better than those provided by any previous car cassette player that I have evaluated.

The amplifier distortion was measured using an AM signal generator to provide output signals of 11 watts into 4 ohms and 1 watt into 4 ohms. At the 11 watt level, the

distortion was moderately high being 4.3% at 100 Hz; 2.6% at 1 kHz; and 0.45% at 6.3 kHz. With the output level reduced to 1 watt these figures dropped down to 1.8% at 100 Hz; 1.5% at 1 kHz; and 0.29% at 6.3 kHz. All of these figures were increased lightly as a result of AM signal generator modulation distortion. The distortion figures are bordering on the unacceptable at 11 watts and generally acceptable at the 1 watt level.

The tone controls were also evaluated utilising the swept signals from the FM signal generator and revealed that the tone controls are effective, providing 9 dB of boost and 8 dB of cut at 100 Hz and 9 dB of boost and 7 dB of cut at 10 kHz.

For the evaluation of the AM stereo tuner, I used a Delta Electronics Inc AM stereo exciter type ASE-1. This particular unit, although designed for converting a broadcast transmitter into an AM stereo transmitter, also fortunately incorporates an extremely linear sample transmitter, the output of which is reasonably good. It is effectively flat from 50 Hz to 7.5 kHz and is only 1 dB down at 11 kHz. The channel separation provided by the exciter is better than 40 dB and consequently this unit provides an almost perfect piece of equipment for the testing which followed.

The measured frequency response of the AM stereo stage was only reasonably good, with a frequency response that extends from 150 Hz to 3.2 kHz (± 3 dB) in the narrowband mode and 150 Hz to 5 kHz in the wideband mode; both results were measured with the tone controls centred at the flat indent position. I found that the high frequency -3 dB point results could be varied slightly (by as much as 0.5 kHz) by choosing different channel frequencies but that the basic bandwidth capabilities are primarily fixed by the IF circuit. These results could be readily improved by the application of maximum treble boost and slightly more again by the application of bass boost.

With full treble boost applied, the -3 dB point is extended out to 7.5 kHz, while the application of maximum bass boost extends the -3 dB point out to 40 Hz. The channel separation in the stereo mode is better than 29 dB in the wideband mode and this does not alter significantly in the narrowband mode.

The AM sensitivity is reasonably good: with 21 microvolts into the dummy car aerial termination, a 20 dB signal-to-noise ratio results with a mono signal and 35 microvolts is required with a stereo signal.

The FM tuner provides a very flat frequency response which extends from 20 Hz to 17 kHz for both left and right channels. The channel separation is only 20 dB mid-band for both left and right channels which is not quite as good. The FM sensitivity is 11 dBf for 26 dB signal-to-noise ratio with a

mono signal and 19 dBf for 46 dB signal-to-noise ratio with a stereo signal.

The overall impressions of the objective performance are that the main parameters for the cassette player, AM stereo and FM stereo, are excellent but some of the ancillary specifications, like channel separation, are good but not outstanding.

Subjective testing

Having confirmed that the unit provides above average performance, I proceeded with the subjective assessment.

This revealed that most of the ergonomic features are well conceived and that in practical use the unit is especially delightful. I used the XR-A740 connected to the XS-700 three-way speaker system which provided above average quality sound when compared with the speaker systems I have previously listened to in a car (or bus or caravan). With these speakers, the performance provided by the cassette player is very good. That does not mean to say that the previous car cassette player units were necessarily inferior, but rather with a speaker system as good as this the quality of the resulting sound is further enhanced.

The incorporation of a bi-directional cassette deck is a must in an automotive situation and this particular deck provides the best of the bi-directional features which the AMS system further enhances. I listened to a number of pre-recorded cassettes and was very impressed with the results. The ability to select local or DX is not a particular advantage during the daytime but really comes to the fore at night. With the local switch activated, the receiver front end effectively 'kills' most of those distant stations which create 'birdies' and 'whistles' as you tune across the dial.

AM stereo does come 'alive' in this receiver, although the quality of that sound is still not yet really comparable to FM stereo. It is still, however, perceptibly better than an AM mono signal and much better than most of the car AM tuners I have listened to. The performance of the FM section is extremely good and, using the longer than normal whip aerial fitted to my son's car, it provided outstanding performance even in low signal strength areas where the vehicle's existing inbuilt FM/AM radio falters badly.

I would have found the six AM and six FM frequency pre-selects a little restrictive if the unit did not also incorporate the scan function. This allows you to quickly tune in other stations which I had not permanently logged. Overall, the XR-A740 provides a performance which warrants almost top marks in every department. With 20 watts of power to play around with in left and right channels, you don't really need a supplementary amplifier and at an RRP of \$499 this particular receiver constitutes truly excellent value for money. ●

SAVE ON QUALITY PRODUCTS FROM PRE-PAK

UHF AERIALS
for BAND 4
or BAND 5
10 element
with 75Ω balun
(Sorry, no mail order) **\$33**

TV SIGNAL AMPLIFIER
4x75 ohm
Outputs
12 dB gain
VARIABLE
Reduced!
FOR...
VHF UHF
FM
was \$69.50
now **\$49.50**

DIGITAL SPEEDO+TACHO for Cars
0-199 KPH 0-9900 RPM
Bright LED
Display
with
SPEED
SENTRY
MONITOR **\$69**
12v neg. gnd.
Buzzer and light indicates
excessive speed - adjust
from 40-120 KPH.

Professional
SOUND
1/2 PRICE!
STEREO
H' PHONES
were \$9.99
NOW... **\$5**

**PUSH-BUTTON
TELEPHONE
DIALERS**
with
last
number
memory
redial
feature. EA
\$15
Easily installed
but not Telecom
approved.

PARTS VALUE PACKS
LUCKY-DIP ASSORTMENTS!
500 1/2W RESISTORS
200 1W RESISTORS
100 CERAMIC CAPS
30 GREENCAPS
45 ELECTROLYTICS
20 POTENTIOMETERS
25 PRESET POTS
30 MICA CAPS
40 RADIO/TV KNOBS
20 VARIOUS FUSES
12 SWITCHES
50 TAGSTRIPS

\$2
EACH PACK
BUY 10,
GET 1
FREE!

DB25 SOCKETS
High Quality
gold-plated
contact pins!
Only
while stocks
last!
EA **\$1.50**

FANS
5" 115vac
OR
220VAC
\$10 ea
EX-COMPUTER

**RADIO CONTROL
REMOTE SWITCH**
12v
DC
CAR alarm model
with 2 transmitters... **\$110**
Single OR Dual CHANNEL
for home, alarms, garage doors,
industrial control etc. These have
extended range to 100 metres,
12,000 programmable codes.
1CH + TRANSMITTER... **\$119**
Extra transmitters, each... **\$40**
2CH + TRANSMITTER... **\$133**
Extra transmitters, each... **\$48**

Ex-Computer Caps
100,000uf 10v 33,000uf 40v
30,000uf 15v 20,000uf 45v
25,000uf 20v 10,000uf 50v
15,000uf 25v 22,000uf 50v
50,000uf 25v 20,000uf 55v
24,000uf 30v
22,000uf 35v
12,000uf 40v
All tested EA
and g'rad **\$5**

**SPEAKER
BOX SALE!**
Sorry, **\$6**
Shop sales
only! ea.

**NEW PRINTER
SWITCH (A-B) BOXES**
WITH DATA
TESTER
LEDS
2x IN
1x OUT or
VICE VERSA!
Ideal for computer
to 2 printers or printer to 2 com-
puters - no power required!
RS232 SERIAL
\$99.50+Tax **\$119**
CENT. PARALLEL
\$99.50+Tax **\$119**

DISCO STROBE
0-12 flashes
per second!
\$25 ea
Ideal for parties,
theatre, dances etc. 240v

**DPDT HI-QUALITY
ROCKER
SWITCH**
20¢ 100
for
50¢ ea. NORMALLY
\$15

WOOFERS
4" 10W \$11.50
6 1/2" 15W \$12.50
8" 60W \$28.90
10" 90W \$48.50
"FREE EDGE" 12" 40W \$44.50
BUILD YOUR OWN SPEAKER'S
**PIEZO SUPER
TWEETERS**
100W 3-30KHz
\$13.50 ea

**LOW IMPEDANCE
MICROPHONES**
3 models,
fitted with
3.5mm
plugs,
etc.
ONLY **\$2** ea

SALE 4CH MIXER
4x600 ohm
INPUTS
MASTERS
VOLUME
\$35 EA

**FM WIRELESS
Microphone** **\$17**
only
Freq. 88-108MHz
Range to 100 metres
Response 50-4KHz

**FM WIRELESS MIKE
and RECEIVER**
for P.A. etc 37-10MHz
Crystal controlled for
stability - range 100
metres maximum.
set **\$89** 9v batt. oper.

VIDEO IMAGE STABILIZER
for VCR to VCR recording
was \$49 NOW **\$19** GREAT
VALUE!

**NEW Replacement
CERAMIC
STEREO
CARTRIDGES**
Now only **\$3.00**

**5 1/4" FLOPPY
DISKS**
DOUBLE
SIDED **\$27** per
10
DOUBLE
DENSITY **\$230** per
100
10
YEAR
GUARANTEE
(limited qty)

**IBM-APPLE
COMPATIBLES**
\$1300 PLUS
SALES
TAX 20%

BUYS PC-XT COMPATIBLE 2 DRIVES
incl. mono graphic card, monitor extra \$249

IBM PARTS AND ACCESSORIES

512K Ram card - no Ram.....	\$129
Mono Graphics card.....	\$295
Colour Graphics card.....	\$329
Mono Text card.....	\$223
Floppy Disk Controller.....	\$99
Hard Disk plus Controller.....	\$1255
384K Multi-Function card.....	\$244
Detachable Keyboard.....	\$171
135W Power Supply.....	\$165
Metal Case, 8 slots.....	\$99

APPLE PARTS AND ACCESSORIES

Z-80 CP/M card. \$ 55	RS232 Serial card. \$ 57
80 Column card. \$ 92	Super Serial card. \$120
Disk Drive card. \$ 55	128K Ram card..... \$239
Pal Colour card. \$ 72	Par'l Print. card. \$ 64
RGB Colour card. \$105	IEEE-488 card..... \$150

Prices
plus
Sales
Tax..20%

IBM-Apple
are
registered
trade
marks.

**1986
EASTER
SHOW-BAG**
\$4.99

SPECIAL OFFER!
Only 500 bags available, heaped with all
kinds of quality electronic parts provided
by our suppliers as product samples plus the
extra goodies we put in!

From RCA, Philips, National Semiconductor,
Motorola, I.T.T., Arista, Plessey, Soanar, IRH
and us, you'll find Transistors, Digital and
Linear IC's, Diodes, LED's, Potentiometers,
Resistors, Capacitors, Switches, Plugs and
Sockets, Knobs, Chokes, Coils, Fuses, Lamps,
Electros, Tagstrips and lot's more! UPTO \$50
WORTH, yours for \$4.99 plus \$2.00 Pack/Post.

**LIGHT DIMMER or
MOTOR SPEED CONTROL
KIT**
700w
UP TO
2000w
WITH RFI SUPPRESSION
\$4.95

**Electromagnetic
COUNTERS**
Non-resettable
24V DC **\$5.50**
24V DC CHASSIS **\$5.50**
110V AC CHASSIS **\$2.50**
220V AC CHASSIS **\$4.95**

**I.E.C. MAINS
PLUG and
SOCKET**
PLUG **\$2.70**
SOCKET **\$2.50**

**NE2 NEON
LAMP**
12v LAMP 25
40mA current EACH
BELOW NORMAL COST.

**FULLY APPROVED FOR AUST.
240v MAINS
6A NOISE
FILTER** **\$39**
for computer,
audio, industrial.

**PLASTIC
12 Pole TERMINAL
BLOCKS** **\$1.20**
240V AC
10AMPS

**I.E.C. QTY 1-10
POWER
LEADS** **\$1.50**
QTY
20+ **\$1.25** ea
Length: average 1-6M

**LAST FEW
AVAIL!**
VIDEO IMAGE STABILIZER
for VCR to VCR recording
was \$49 NOW **\$19** GREAT
VALUE!

**3" 5 MHz
OSCILLOSCOPE**
AC-DC, 10mv per div
Auto-triggering
Solid state
Internal calibrate
New with warranty
\$195 (was \$295)
GREAT VALUE!

**5" 10MHz
OSCILLOSCOPE**
AC-DC, 10mv per div
Auto-triggering
Solid state
Internal calibrate
New with warranty
\$325 (was \$420)
NEW! 4 ONLY!

**NEW! RF
SIGNAL
GENERATOR**
100KHZ-100MHz
was \$139
now **\$89**

**HIGH QUALITY
HEAVY DUTY
SOLENOIDS**
24V AC **\$3.90** LOW PRICES!
24V DC **\$5.50** 110v ac **\$1.25**
240v ac **\$4.50**

**NEW Replacement
CERAMIC
STEREO
CARTRIDGES**
Now only **\$3.00**

10 FUSES FOR \$1
3AG
32mm x 6mm, TAKE YOUR PICK!
250mA, 500mA, 750mA, 1A,
1.5A, 2A, 3A, 5A, 7.5A, 10A,
15A, 20A, 25A, 30A. CHEAP!

**ASST. POTENTIOMETERS
LUCKY DIP SPECIALS**
20 for **\$3** ALL
NEW,
100 for **\$10** MIXED
250 for **\$20**

DESOLDER WICK
1.7 metres in
plastic
dispenser
\$3 for \$4

RELAYS
240V AC
COIL
4 Changeover
10 Amp contacts
WHILE THEY LAST! **\$4.50** EA

**DOUBLE
SIDED
DOUBLE
DENSITY** **\$27** per
10
\$230 per
100
10
YEAR
GUARANTEE
(limited qty)

LM3900
OR EQUIV. RCA 3401
requires
price of **\$39** EA
10+
2¢
ea.

C106 SCR
200V 4A **\$32** ea.
10+
2¢
ea.

resistors **\$2**
All Wanted Values
1 ohm-10 Meg/ohm.
Packs of 100
ONE VALUE
1/2 WATT
OR
1/4 WATT
CARBON FILM

CAPACITORS
CERAMICS
PACKS OF 100
ONE VALUE
\$4
Greencaps
2 FOR THE
PRICE OF 1

**1.5v-3v DC
HOBBY
MOTORS**
\$1.50 ea
P&P **\$3** +5% OF ORDER
VALUE!

**PRE-PAK
electronics p/l**

**1a WEST ST,
LEWISHAM, NSW**

569-9797
24 HR PHONE ORDER SERVICE

**Phone or mail order
BANKCARD accepted**

BMAC: THE NEW TV FORMAT

Australia's adoption of the BMAC satellite transmission format has been described as a brave move and, less sceptically, as innovative. These opinions are politically and economically based as much as anything else; and it is worth, however, looking at the technical entailments.

P. S. Chung

School of Electrical Engineering
& Computer Science
University of New South Wales

WHEN AUSSAT I was launched last August, Australia was the first country to experiment with the new satellite TV transmission format, BMAC. The MAC (multiplexed analogue components) system differs significantly from conventional broadcast systems like PAL or NTSC. It is a hybrid system using digital transmission techniques for audio and data in combination with analogue component video. The chrominance and luminance signals are time — rather than frequency multiplexed, eliminating cross-colour and cross-luminance effects. The data format allows six high-quality digital audio channels and one utility data channel.

A new system

Today's terrestrial colour television systems were derived from the black and white transmission of the '40s. The technique adopted for adding colour was constrained by two requirements. The colour transmission system had to be compatible with existing monochrome receivers and the additional colour information had to be fitted within the existing transmission bandwidth.

Unfortunately, due to the imperfect colour receivers, the frequency multiplexing of chrominance and luminance signals causes degradation to the received picture. The most common type of defect is 'cross-colour' where high-frequency luminance

details will be misinterpreted as colour information.

Other disadvantages of the existing systems include 20 per cent of the transmission time wasted on blanking; the aspect ratio for conventional receivers of 4:3 and being incompatible with wide-screen display; and the use of scrambled signals in controlling viewer access being difficult and expensive.

Furthermore, the biggest consideration in any direct broadcast from satellite (DBS) system is the noise problem caused by the long transmission path involved and the power constraint on the transponder. Neither PAL nor NTSC are designed for use in noisy environments.

The BMAC system

The deficiencies of the present colour transmission system were recognised long ago. It was Dr Bruch of Germany who put forward the principle of broadcasting separate luminance and chrominance components with time compression to reduce the cross-colour effects in the early '70s. The Japan Broadcasting Corporation (NHK) adopted it with a view to its use in high definition television (HDTV). Nevertheless, we must give credit to IBA (Independent Broadcasting Authority) in UK for applying this principle to DBS.

The formation of a MAC line

The digital audio/data and the FM modulated analogue luminance and colour difference signals of a BMAC line are transmitted in time-sequence (see Figure 3). The three separate components are never present at the same time, thus avoiding cross-interference between sound and vision, and the cross-colour effect.

The uncompressed luminance and chrominance bandwidths are 5 MHz and

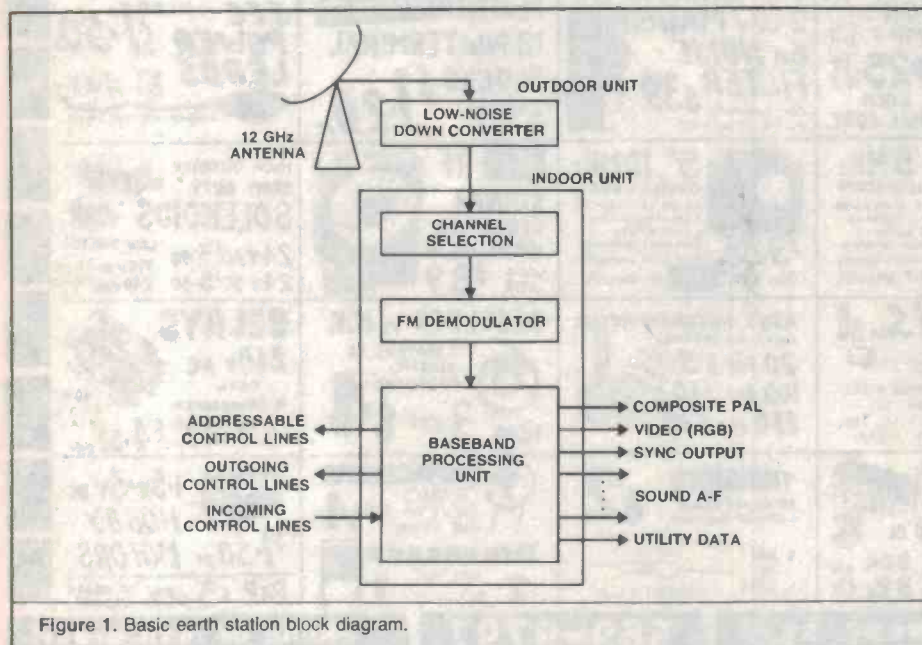

Figure 1. Basic earth station block diagram.

1.3 MHz. Before transmission, both the analogue components have to be time-compressed. The luminance signal is compressed by a factor of 3:2 (from 52.5 μ s to 35 μ s) and each colour-difference line is compressed by a factor of 3:1, reducing the time to 17.5 μ s.

As there are two colour-difference components in the PAL system (the blue and red colour-difference signals, U and V), it is necessary to transmit the full colour information on alternate lines.

To form a MAC video line using the time-compression method, the luminance signal is first sampled at a frequency $910f_H$, where f_H is the horizontal or line frequency of 15.625 kHz. The samples corresponding to the line-blanking interval (12 μ s) will be discarded, leaving 750 usable samples. These are then stored in a line store, read out at a higher frequency of $1365f_H$ 21.33 MHz and then restored to an analogue form for transmission. Similarly the colour-difference signal is sampled at $455f_H$, leaving 375 active samples. The total number of usable video samples is 1125, with a guard band of six samples between the luminance and the chrominance components.

Line blanking

In an unscrambled MAC line, a total of $(1365-1125-6=)$ 234 samples form the line blanking period which is filled with 4-level data symbols, each symbol carrying 2 bits of information. These bursts of data are transmitted at 14.3 Mbit/s, corresponding to a non-time compressed data rate of about 1.56 Mbit/s. Each data symbol will occupy three sample periods, allowing a total of 78 symbols per line blanking period. These data symbols are used to carry digital audio and data services and to provide a clock synchronisation signal in the form of a 10-cycle reference burst at 3.55 MHz (allocated 20 data symbols) for the receivers. When scrambled, the line blanking period varies from line to line and the number of symbols varies pseudo-randomly at about an average value of 78. The position of the reference burst is also chosen pseudo-randomly on each line and is not related in any way to the start of the active video signal.

For the audio coding format, adaptive or enhanced delta modulation at a sample rate of $13f_H$ (303.125 kbit/s) and a dynamic range over 84 dB will be used. Delta modulation is a form of analogue-to-digital system where the output code is a stream of 1s and 0s representing the relative changes in the signal amplitude. Delta modulation allows a lower cost receiver to be used and recent research shows that the enhanced version has a quality equal to that of an equivalent pulse code modulation (PCM) system, plus the benefit of a much higher dynamic range. The audio system was designed by Dolby with variable pre-emphasis

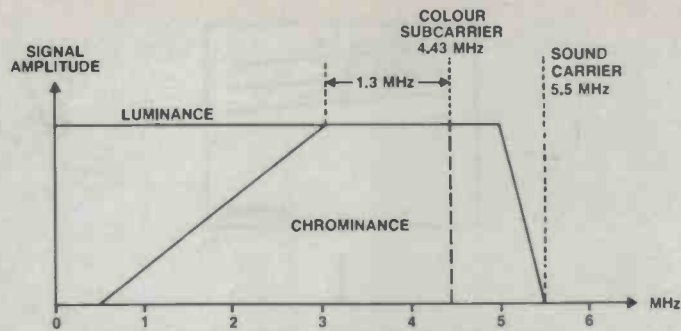

Figure 2. PAL baseband frequency. Note how colour and brightness are mixed in the shaded region.

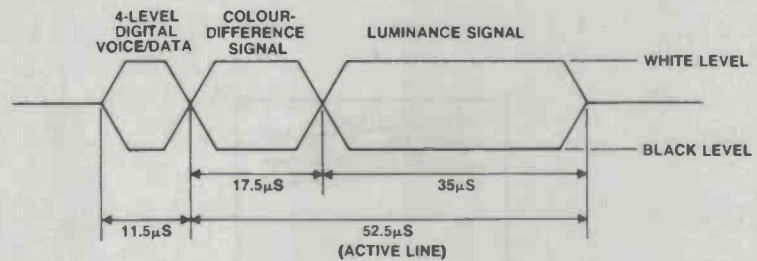

Figure 3. A normal B-MAC line.

to increase the signal-to-noise ratio. Thirteen bits per audio channel of 15 kHz bandwidth are allocated in each line blanking period and any number of the six digital audio channels may be reassigned as an additional data channel.

Vertical blanking interval

The lines of this interval are of conventional length (ie, 50 lines) and carry the 78 data symbols, plus an additional 377 symbols at the $455f_H$ rate normally reserved for the video components. The first line of each field (ie, lines 1 and 313) contains a continuous reference burst known as the clock recovery packet so that data can be immediately captured in the first field of receiver lock-up. Lines 2 and 314 contain a unique code word followed by an identification se-

quence known as the synchronisation code packet which provides synchronisation for the complete video/data multiplex. Synchronisation is therefore extremely rugged, yet it requires only 0.2 per cent of the total time as opposed to over 20 per cent required by the PAL system. It has been demonstrated that a full picture can be locked in even at 0 dB signal-to-noise ratio. Lines 3 and 315 carry an encrypted service description packet for pay-per-view services. Lines 4-8 and 316-320 contain conditional access packets for authorised subscribers to access the service system. Lines 9-13 and 321-325 can carry 200 pages of encrypted or clear text available to all or any specific user with 20 second access time. The remaining lines are for VITS (vertical interval test signals), an additional 200

TABLE 1. Line numbering and functions of a B-MAC picture frame

Line	Number	Horizontal Data Period	Contents of Active Line Period
1	313	78 symbols	clock recovery packet (377 symbols)
2	314	78 symbols	synchronisation code packet
3	315	78 symbols	service description packet
4-8	316-320	78 symbols	conditional access packet
9-13	321-325	78 symbols	system teletext packet
14-24	326-337	78 symbols	VITS, teletext, other data signals
25		78 symbols	U and luminance transmitted
26	338	78 symbols	V and luminance transmitted
27	339	78 symbols	U and luminance transmitted
↓	↓	78 symbols	luminance and U (odd) or V (even)
311	623	78 symbols	U and luminance transmitted
312	624	78 symbols	V and luminance transmitted
	625	78 symbols	U and luminance transmitted

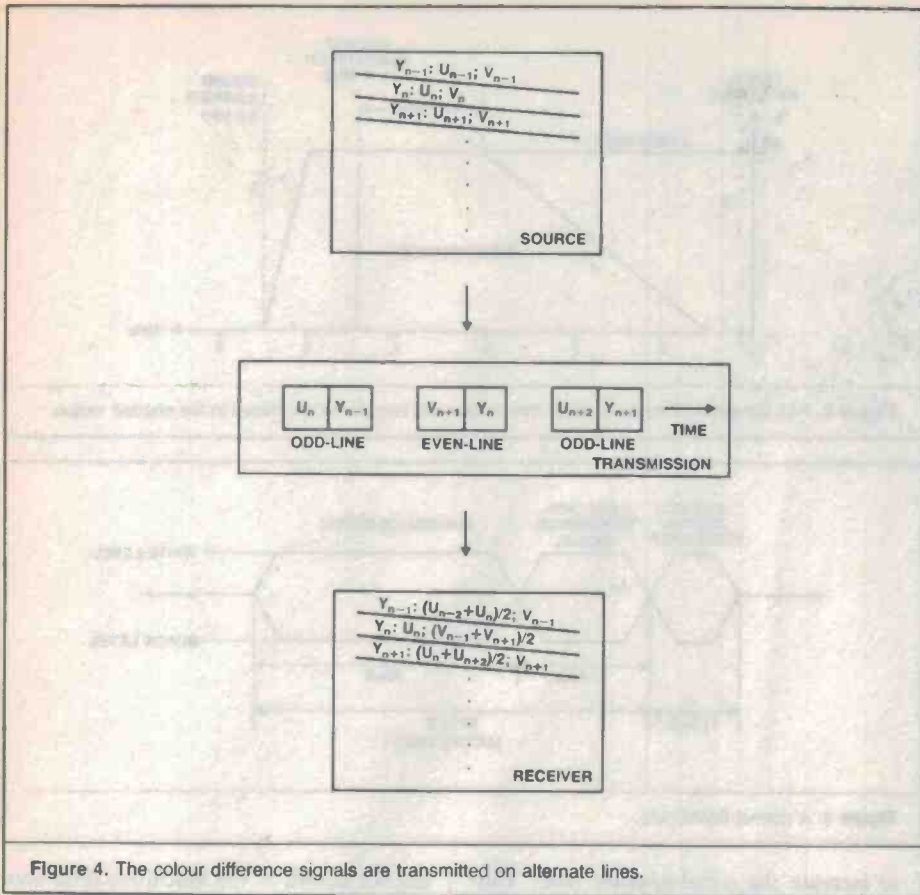

Figure 4. The colour difference signals are transmitted on alternate lines.

pages of teletext capability or other data services which may include film sub-titles as a user option, sub-titles for the deaf, general and personal messages, programme guides, and individual account status for monthly billing. All these data services can be encrypted for security purposes and for controlling viewer access. Figure 6 describes the line numbering and functions of a BMAC picture frame.

Extended MAC for widescreen pictures

In order to provide widescreen pictures, the length of the sound/data burst can be reduced in order to allow additional picture information to be transmitted as shown in Figure 6. By this means the luminance picture information is carried in place of the sound channels, but still allowing for a stereo sound channel to accompany the pictures. Colour-difference information for the widescreen picture can be extended to the vertical blanking interval. There is still sufficient capacity for four teletext lines per field plus one VITS/line per field.

The aspect ratio achievable in this way is approximately 4.7:3 compared to 4:3 for conventional receivers. There is complete compatibility with the standard receivers

**Now
Get
Serious!**

**At your
Newsagent
Now!**

**... and
have Fun!!**

!VACANT POSITIONS!

The Job: Writing and Sending in Games Programs to fill Vacant Positions on Various Pages in forthcoming Issues of *Computer Fun & Games*.

The Responsibility: Keep'em Funny and Gamey, er Gamsey, keep'em original, and all-your-own. Be willing to accept \$25 for each Game we Publish that you've written.

Hours: Suit yourself.

Details: Inside any copy of *Computer Fun & Games* and the March Issue of *Electronics Today!*

**Or Simply Send \$1.80 plus \$1.00 post and packing to —
Computer Fun & Games, PO Box 227, Waterloo 2017 NSW.**

since the amounts of left and right sides of the picture in the extended MAC signal are variable. The proportions of left and right extended picture being transmitted can be signalled in the frame synchronisation line.

International standard

Efforts are being made to standardise the international broadcasting satellite TV transmission format. Although Australia is the first country to commit itself to use the BMAC format for the Aussat satellites, there is no firm indication by the international broadcasting communities on the standard DBS transmission system. In a meeting held last year in Brussels, the EBU (European Broadcasting Union) and European manufacturers recommended CMAC and D2-MAC for DBS, thus paving the way for a fully operational system when the first European broadcasting satellite is scheduled to be launched sometime this year. They believe that the creation of a unified European market constitutes both a strategic objective for Europe and a necessary precondition for the economic viability of these new services.

Japan has been pushing very hard since 1970 for the introduction of the 1125-line 5:3 aspect ratio high definition TV system, the definition of which will rival that of the 35 mm slide projection. Early last year, NHK demonstrated a new HDTV system using multiple sub-Nyquist sampling encoding (MUSE) system which will require considerably less bandwidth than previous HDTV systems. Using the world's first operational DBS, the BS-2a, they are able to experiment with the HDTV system to service remote areas, outlying islands and households located in congested urban districts. DBS will expand further with the future launching of BS-2b and BS-3a.

In the US, the major broadcasting network CBS has made a major commitment to HDTV based on a 1050-line dual channel transmission scheme. Existing receivers can receive the conventional NTSC 525-line broadcasts on a single channel.

References

- J. Fairall, "BMAC — We'll be first to use it", ETI, pp 10-13, March 1985.
- Department of Communications, "Transmission Standard for HACBSS", November 1984.
- Department of Communications, "HACBSS Earth Station Specification", December 1984.
- H. Mertens and D. Wood, "The CMAC/packet system for DBS", EBU Review, Technical No 200, August 1983.
- T. Fujio, "HDTV Systems: Desirable Standards, Signal Forms and Transmission Systems", IEEE Trans on Comm, Vol COM-29, pp 1882-1891, 1981.

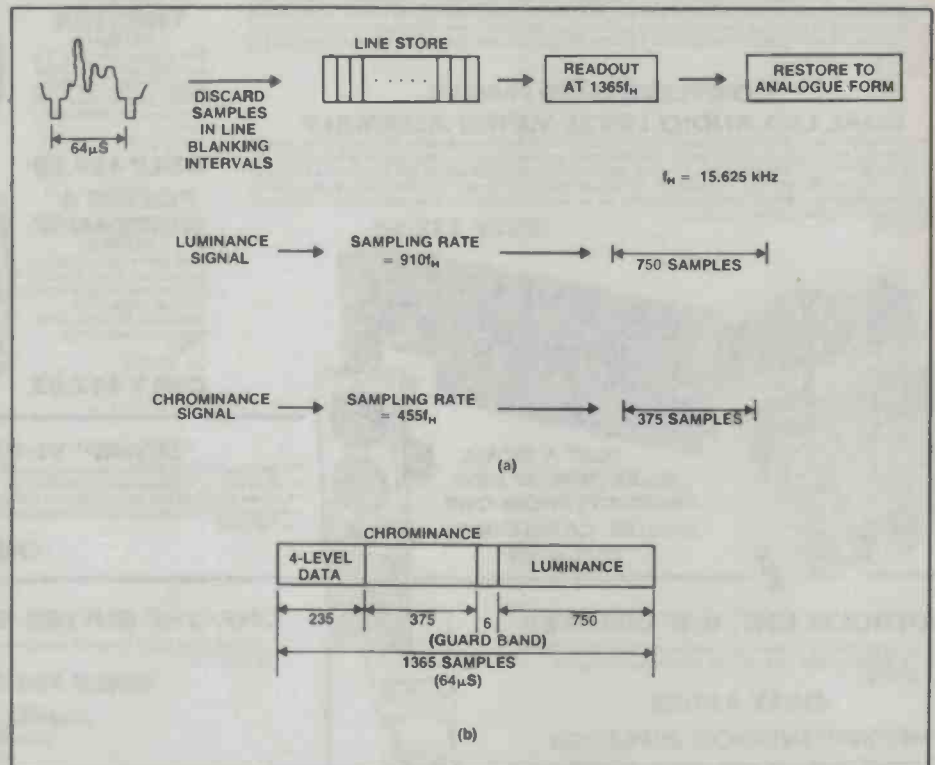

Figure 5. Formation of a BMAC line; a) time compression; b) complete line format.

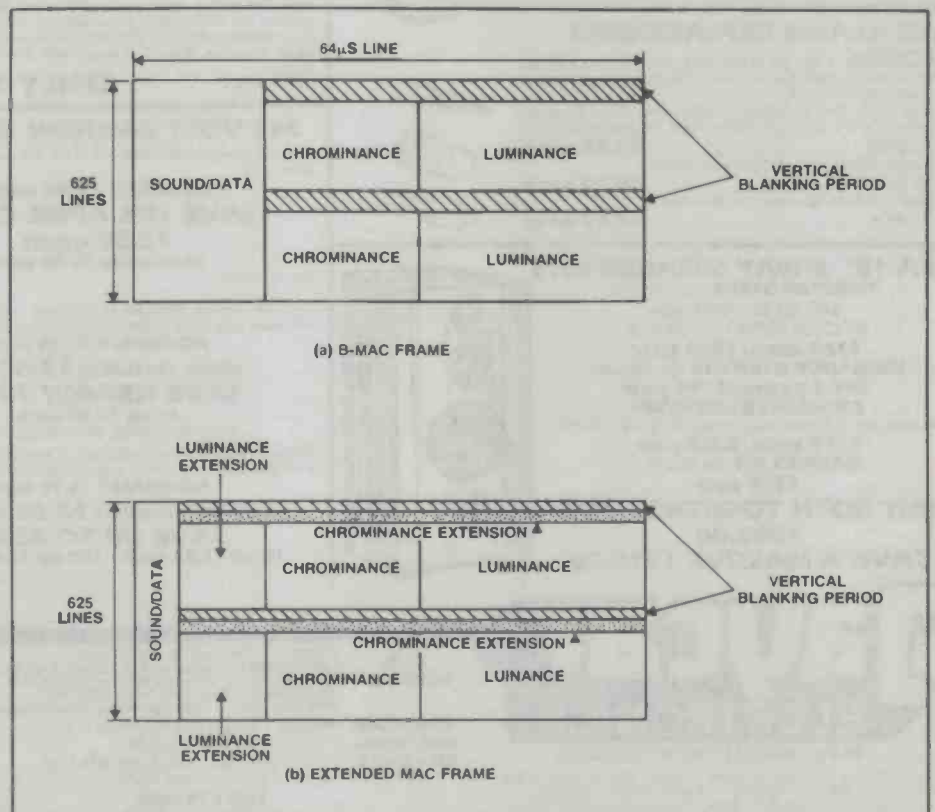

Figure 6. How BMAC can be used to widen the picture.

JAYCAR TELEMAIL 008 022 888 TOLL FREE

80 + 80 PRE-MAIN AMP

A complete preamp and high power amp - with power supply electronics in the same package! All that you need to connect is a power transformer and signal source! It features TWO huge heatsinks for the power transistors, bass, treble and midrange controls, a MICROPHONE preamp and mixer pot, balance and volume control. There is facility for preamp out (to dub from source to tape) as well as phono out. All in all it's a very well thought out unit. The main board measures 245(W) x 240(D). The heatsinks 130(W) x 75(D) x 70(H) are connected to the main amp board by about 150mm of wiring.
Cat. AA-0310

COMPLETE UNIT \$149.95

DUAL LED AUDIO LEVEL METER ASSEMBLY

This meter enables you to display power levels from -30dB to +5dB. The meter operates directly from the speaker leads. It does not consume any amplifier power. The level meter is powered by any voltage source between the range 3-20V so it is ideal for 12V automotive use. Ten LEDs are provided for each channel, the first 4 LEDs in each channel are green (-30 to -5dB) the next 2 are yellow (-1 & 0dB) and the next 3 are red (+1 to +5dB) a peak LED yellow is also used to indicate an 'overload' condition. The meter can be calibrated to operate on amplifiers from 1-200 watts! A circuit for mains power supply is included.
Cat. AA-0326

ONLY \$32.50

JUST A SMALL SELECTION OF NEW PRODUCTS FROM OUR 1986/87 CATALOGUE - OUT NOW

OUTDOOR UHF/VHF DIPLEXER

Mounts directly on to TV mast, connect two aerial cables (UHF & VHF) to diplexer, then only run one cable down to the TV.
Cat. LT-3014

ONLY \$11.95

UHF/VHF INDOOR DIPLEXER

This device allows you to connect 2 antennas (UHF & VHF) to the one socket on your TV. Output 75 ohms to TV.
Cat. LT-3013

ONLY \$10.50

CAR ALARM REPLACEMENT GLOBES

We are asked many times for replacement globes for flashing switches/bezels for car alarms. We now stock the most common types.

- 1) Possibly the most common. 12 volt push-in. Metal flange up two sides. Used in Red Light, Yellow Light, Pirahana and Cobra. Cat. SL-2638 **\$4.50 each**
- 2) Used in Yellow Light and possibly others. Cat. SL-2637 **\$4.50 each**
- 3) Used in Yellow Light and possibly others. Cat. SL-2636 **\$4.50 each**

VIFA 10" 3-WAY SPEAKER KITS

TWEETER D19TD Cat. CT-2019

\$42.50 ea / \$89 pair

WOOFER P25WO Cat. CW-2136

\$169 each / \$338 pair

MIDRANGE D75MX-10 Cat. CM-2086

\$99.50 each / \$199 pair

CROSSOVER NETWORK

Not a kit, now a factory built precision unit. Cat. CX-2632

\$119 each / \$238 pair

CABINET KIT Cat. CS-2652

\$319 pair

BUY BOTH TOGETHER FOR

\$999.00

SAVE A MASSIVE \$110.00

Jaycar ELECTRONICS

Incorporating ELECTRONIC AGENCIES

Carlingford, Hurstville, Gore Hill, Brisbane - Mon-Fri: 9am - 5:30pm
Sydney and Concord - Mon-Fri: 8:30am - 5:30pm
Sydney, Carlingford, Hurstville - Thursday nights until 8:30pm
Brisbane - Thursday night until 8pm
Sydney, Carlingford, Hurstville, Brisbane - Saturdays 9am - 12 noon
Gore Hill - Saturday 9am - 4pm

CONCORD NOT OPEN ON SATURDAYS

NUMBER 1 FOR KITS

N.S.W. SHOWROOMS

SYDNEY 117 York Street Tel. (02) 267 1614
CARLINGFORD: Cnr. Carlingford & Penant Hills Road Tel. (02) 872 4444
CONCORD: 115/117 Parramatta Road Tel. (02) 745 3077
HURSTVILLE: 121 Forest Road Tel. (02) 570 7000
GORE HILL: 188/192 Pacific Highway (Cnr Bellevue Avenue) Tel. (02) 439 4799

QUEENSLAND MAIL ORDERS: HEAD OFFICE:

BURANDA 144 Logan Road Tel. (07) 393 0777
P.O. Box 185, CONCORD 2137
115-117 Parramatta Road, CONCORD 2137
Tel. (02) 747 2022 Telex: 72293

POST & PACKING
\$5 - \$9.99 \$2.00
\$10 - \$24.99 \$3.75
\$25 - \$49.99 \$4.50
\$50 - \$99.99 \$6.50
\$100 - \$198 \$8.00
Over \$199 \$10.00

ROAD FREIGHT ANYWHERE IN AUSTRALIA ONLY \$13.50

FOSTER HORN TWEETER H016N17

This tweeter is brilliant. It is very bright with crisp sound. Frequency Response 5kHz - 40kHz, system power 100 watts rms. SPL 96dB/w @ 1 metre.
Cat. CT-2016

ONLY \$29.50

FOSTER 4" WIDRANGE C100K03

Ideal where high quality is needed, but where space is at a premium. Nominal power 3W max power 10W. Resonance frequency 80Hz, frequency response 80 - 17kHz.
Cat. CE-2312

ONLY \$17.95

FOSTER DOME TWEETER D025N25

System handling 150 watts rms. Resonance frequency 1.2kHz. Frequency response 3kHz - 30kHz. SPL 91dB/w @ 1 metre
Cat. CT-2018

ONLY \$31.00

FOSTER DOME MIDRANGE CM-2090

Bright, crisp, clear midrange. Suits system power up to 150W rms. Frequency resp. 1.2kHz - 8kHz. SPL 92dB/w @ 1 metre. Resonant freq. 520Hz.
Cat. CM-2090

ONLY \$75.00

'SHARP' VHF/UHF TUNERS BACK!

We had these last year and they were very popular. Now we have another scoop buy at a special price! If you have the technical skills, you can convert that old VHF only TV to receive UHF channel 28 again! (A schematic is provided but we cannot guarantee that the unit will work with your TV). It is an ideal experimenters unit as it covers both the entire Australian VHF band as well as the Australian UHF band. Tuner includes attractive front panel knobs, etc.
Cat. DM-9004

ONLY \$19.95

UHF/VHF GUTTER GRIP

A combination aerial for good reception areas.
Cat. LT-3175

ONLY \$44.95

UHF ONLY TV ANTENNA

This UHF aerial is designed for channel 28 reception for all capital cities. Use with a diplexer to combine with VHF antenna. This antenna has 10 elements and a reflector. The reflector picks up more signals and reflects them back to the aerial for better overall signal reception. Beware of aerials with less elements and no reflector.
Cat. LT-3180

ONLY \$53.50

240 VOLT CANNON MADNESS

Genuine Cannon XLR-LNE-11C 240 volt mains line female connector.

USUALLY \$9.95 each
SAVE 75% APRIL ONLY
\$2.50 each
50 or more \$2.00 each

Cat. PS-1002

Genuine Cannon AXR-LNE-32 240 volt mains chassis male connector (the mate to the XLR-LNE-11C above).

NORMALLY \$7.95 each
APRIL MADNESS \$2.50 ea
SAVE NEARLY 70%!!
10 up \$2.00 each
(BELOW NORMAL WHOLESALE COST!)

Genuine Cannon 15 way right angle 'D' subminiature. That's right a 15 way PCB mount right angle female connector.

NORMALLY \$5.75 each
APRIL MADNESS \$2.00 each
SAVE UP TO 83%!!
10 up \$1.50 each - 100 up \$1.00 each!!



MAIL ORDER VIA YOUR PHONE

High-speed digital storage oscilloscope

The new Gould 4050 digital storage oscilloscope, is a high-speed instrument whose twin 100 MHz digitisers allow it to be used in electronics and analytical applications not previously suited to DSO measurements.

Featuring a real-time oscilloscope bandwidth of 35 MHz in addition to its high-performance digitising capabilities, the Gould 4050 has been specifically designed for ease of use and flexibility in a wide variety of applications.

Sophisticated software algorithms accessed by an optional waveform-processor keypad allow a variety of mathematical and processing operations to be carried out on waveforms stored in the 4050's memory, and make it easy to customise the machine to allow, for example, results to be displayed directly in engineering units using on-screen alphanumeric.

The new instrument uses two 8-bit 100 megasample-per-second analogue-to-digital converters, allowing high-speed signals to be captured with up to 10 ns resolution. Each channel has its

own converter, so that the same accuracy, resolution and retention of detail are obtained whether one or both input channels are being used.

Each channel of the 4050 has its own 1K word memory, and the contents of either or both memories can be held to allow new data in one memory to be compared with information held in the other. In addition, either trace can be stored into one of five non-volatile back-up stores and recalled to a third 'reference' trace for further comparisons.

The 4050 incorporates comprehensive trigger facilities, including a variable pre-trigger feature which allows data occurring before and after the trigger point to be displayed, allowing detailed study of 'cause-and-effect' phenomena. A trigger window control allows the oscillo-

scope to be set to trigger whenever a signal leaves a pre-set voltage band, thus aiding the detection of unpredictable transient events.

As a 35 MHz bandwidth real-time oscilloscope, the 4050 has a maximum sensitivity of 5 mV per division and a maximum sweep rate of 200 ns per division. Maximum sensitivity using x5 magnification at 15 MHz bandwidth is 1 mV per division.

In the digital storage mode, the 4050 provides timebase ranges from 100 ns per division (with x10 magnification) to 5 seconds per division.

The 4050 can be used to capture video signals via the built-in active TV sync separator, with either TV line or TV field triggering. The optional waveform processor unit also allows individual lines of a TV signal to be stored for detailed examination.

A variety of interfaces allows the 4050 to be used as part of an integrated measuring system or for hard-copy output. For example, a captured waveform can be

directly plotted to either an analogue recorder or a digital plotter, which will plot out both channels and the graticule on request, changing pens as required to differentiate between the traces and the graticule.

The IEEE-488 (GPIB) interface allows the 4050 to be used as an integral part of an automated measurement system. Built-in software means that easy-to-understand, high-level commands are provided for most control settings, making the instrument very easy to use. In addition, a software package, the SK5523, is available for the IBM-PC, allowing the computer to be used to control the instrument and store waveforms on disk for subsequent processing and analysis.

For further information contact Elmeasco Instruments, 15 McDonald St, Mortlake, NSW 2137. (02)736-2888.

SCOPE ETC 60L SOLDERING STATION



This new soldering station offers some new attractive features which direct it more towards a production or dedicated hobbyist's environment.

The soldering iron is equipped with a 60 watt element and is driven by 24 Vac. The heater circuit is encapsulated in ceramic, and is electronically switched to reduce transient voltage spikes.

The range of temperatures at which the tip can be set is continuously adjustable from 200°C to 470°C. This temperature is specified as maintainable within $\pm 4^\circ\text{C}$.

A slider is used to set the tip of the soldering iron to the desired temperature. This slider can be locked into a particular setting for situations where the temperature of the tip is critical.

To give the user some idea of the temperature of the tip, there is a three colour LED bar display. This is useful when roughly setting the tip temperature, also it gives you some idea as to how soon you can use the iron when it is heating up.

For applications where less heat or a finer tip are required, there is an optional 30 watt 'pencil' soldering iron. This soldering iron is connected to the same metal screw connector on the soldering station as the larger iron.

Consideration has been given to MOS devices in two ways by Scope with this product. Firstly, the tip can dissipate static to earth and secondly, voltage spikes are reduced by electronically switching the heating circuitry.

The 60 watt iron supports seven different types of replacement tips, ranging in breadth from 0.4 mm to 3.2 mm. A 1.6 mm tip is provided as standard. The 30 watt iron supports four different types or replacement tips, ranging in breadth from 0.4 mm to 2 mm. All of these

tips are electrolytically plated with iron and pre-tinned to reduce corrosion.

Other features of this soldering station include burn resistant flex, an optional soft rubber grip, and for left handed solderers, the option of mounting the soldering iron rest on the left hand side of the station.

Having used the soldering station extensively myself I found it more than adequate for my needs. What I appreciated most was the fast heating recovery time, which was especially useful when soldering large quantities of integrated circuits.

After using the soldering iron for long periods without a break I did not feel any discomfort; this comes from it being light and well balanced. The rubber grip was also appreciated when using the iron for extended periods of time.

The approximate pre-tax price for this product is \$145, and the optional 30 watt pencil iron, about \$45. Overall, I would say that for hobbyists requiring a temperature controlled soldering iron who have a large volume of soldering to do, this soldering station would adequately fulfill all needs. This soldering station would also be equally suitable to production workers and technical staff.

— Neale Hancock

IEEE programmable 11½ decade synthesiser/function generator

A fully IEEE bus equipped 0.1 MHz to 50 MHz frequency synthesiser/function generator, offering a wide range of waveforms and modulation modes, has been introduced by Philips Test & Measurement. The fully programmable PM 5193 uses a crystal oscillator to provide high frequency accuracy and stability. Pushbutton operation with LED indication and clear and complete digital readout makes the instrument particularly easy to use.

Eight different waveforms are available including sine, square, triangular, ramp, Haversine and pulses; transition time for pulses is 3 ns. A broad range of modulation facilities is provided, with AM, FM and gating of both in-

ternal and external signals. Other features include linear or logarithmic sweep over the full frequency range, and counted burst. The ac output can be set as peak-to-peak or rms voltage or in dBm with separate independent dc selection. Attenuation is possible by selection or programmable step.

Manual operation uses pushbutton selection and setting of all parameters. Controls are split logically into four groups, covering waveform, frequency, modulation and output characteristics, with a common numerical keyboard for values. Separate readouts provide unambiguous indications of each parameter. Up to nine front panel settings can be stored in a non-

volatile memory.

Full remote programming of the instrument is possible using the integral IEEE (IEC) bus interface which is supplied as standard. Local lockout enables manual alteration of controls during automatic operation. The bus address for the instrument is set on a three-digit LED display on the front panel using the numeric keyboard.

A range of advanced facilities is provided for use with an IEEE (IEC) bus controller, including an identification mode for instrument type and software version. Other facilities include service request and a bus-learn mode which allows remote interrogation of local manual settings.

The extensive range of modulation facilities includes internal/external AM from 0 to 200 kHz with modulation depth programmable from 0 to 100 per cent; internal/external FM from 10 Hz to 200 kHz with frequency deviation programmable over the same range; internal/external gating from 10 Hz to 200 kHz with modulation programmable; and both linear and logarithmic sweep over the full 11½ decade frequency range.

Sweep facilities include single or continuous modes, hold, reset and programmable sweep times from 10 ms to 999 s.

BRIEFS

Small digital multimeter

Dick Smith Electronics' new personal digital multimeter (Cat Q-1555) is the size of a pocket calculator, measuring 56 x 108 x 10 mm and weighing only 80 g (including batteries). It's ideal for on-the-spot testing of electrical and electronic appliances and retails for only \$49.95. The 3.5 digit LCD display provides accurate readings even under adverse light conditions and can be used as a millivolt meter (up to 20 kHz). For more specs contact your local DSE store.

Power supply plus DVM/DAM

The Chung Yu Electrics digital power supply is a dual purpose unit which can be used as a power supply or DVM/DAM and is therefore suitable for applications in schools, laboratories and manufacturing plants. Features include digital display and automatic protection device for short circuit and overload. At the same time readings of constant voltage and current can be taken. It may be used in double voltage and current output in series and parallel. Dual output ranges vary from 0-15 V, 0-4 A to 0-100 V, 0-0.5 A. For further information contact Paton Electronics, 90 Victoria St, Ashfield, NSW 2131. (02)797-9222.

Bar codes and polling on Anadex printers

The ability to generate and print labels, bar codes and large characters is now possible using an inexpensive option on the Anadex DP9625B series of printers. The optional board plugs into the main circuit board within the printer and can be programmed using simple commands to print labels with up to 3000 printable locations, print characters up to 16 times height and width and print bar codes in either code 39 or 2 of 5 single or dual pass. For further information contact Datascape, 44 Avenue Rd, Mosman, NSW 2088. (02)969-2699.

PSE power supplies

Standard Communications Pty Ltd has released its new range of Electrophone PSE Series 240 Vac to 13.8 Vdc power supplies. The range includes the PSE-124 4 amp, PSE-126 6 amp and PSE-1210 10 amp (peak current rated at 50% duty cycle). All models meet SAA and DOC requirements for use with two-way radio equipment. For further information contact Standard Communications, 6 Frank St, Gladesville, NSW 2111.

Universal programmer

The new SGUP-85 universal programmer operates through a dual function 20 keypad and 40 character LCD display or remotely via a computer. Standard features are 32 x 8 RAM buffer, built-in edit commands, RS232 interface and Centronics interface. It uses plug-in modules for each device family, reducing the overall cost of the programmer. The EPROM module can program up to four devices at a time or read and write to two EPROMS for 16-bit applications. Single chip microprocessor and IC functional test modules are also available. For further information, contact AJ Distributors, 44 Prospect Rd, Prospect, SA 5082. (08)269-1244.

Logic analyser — an oscilloscope for digital technicians

Kent Instruments (Australia) has introduced a low cost logic analyser the M7001. It can be configured as either 16 channel, 50 MHz, 2000 words or 32 channel, 25 MHz, 1000 words or 8 channel, 100 MHz, 2000 words and has an additional 8 channels for trigger qualification. The M7001 features non-volatile menu, formatting and search word memories and selectable numeric formats including hexadecimal, binary, octal and ASCII. All information is displayed on a 9 inch screen. Remote control is possible via an RS232 interface and IEC bus interface. For further information contact Kent Instruments, 70-78 Box Rd, Caringbah, NSW 2229. (02)525-2811.

HI-COM UNITRONICS INTERNATIONAL P/L

Shop 7, President Lane, Caringbah, N.S.W. Australia 2229

Phone: (02) 524-7878. After Hours: 522-4395

P.O. Box 20, Sylvania, N.S.W. Australia 2224. Telex: 72573 MAMS

IBM XT COMPATIBLE COMPUTER

Code # Description RRP Incl. Sales
All computer boards have 24 hrs burn in test prior delivery (Japanese prices in brackets) tax



- CA1605 Super XT board — 16 bit 8088CPU 4.77 MHz optional 8087, 8 expansion slots on board 256K RAM expandable to 640K (\$438) \$360
- CA1606 Color graphic card — RGB & monochrome text 40/80x25, graphic 320/640x200 light pen adaptor available (\$270) \$240
- CA1703 Diskdrive card, handle 4DS/DD D'S+cable (\$120) \$108
- CA1604 Printer card with cable \$105
- CA1607 Monochrome graphic card + printer port \$270
- CA1614 Multifunction card, 384K RAM, RS232 & printer port, real time clock/calendar (\$408) \$384
- CA1620 Metal case 8 slots hinged slip top \$110
- CA1624 Diskdrive DS/DD Teac slimline 5.25" \$288
- CA1625 Diskdrive DS/DD Teac 55F 80 tracks 5.25" \$330
- CA1628 NEC 20M hard disk & DTC controller \$1599
- CA1629 Quibie 20M hard disk & controller card \$1560
- CA1631 Detachable keyboard, 10 function/83 key \$168
- CA1650 Powersupply 135W, rear SW, 4 drive cable \$186
- CA1651 Powersupply 135W, side SW, 4 drive cable \$210
- CA1660 Ambre/Gr. 12" monitor 18 MHz swivel, non-ref \$288
- CA1661 Ambre/Gr. 12" monitor high res. 9 pin O/P \$240
- CA1665 Intra 14" RGB color monitor, 0.31mm dot display 80x25, 18 MHz, suit IBM or Apple \$750
- CA1666 Cubie 34cm colour monitor RGB 80x25 \$780

DOT MATRIX PRINTER

Sakata SP1200 plus \$529
120CPS, NLQ, IBM graphics, italic, large ribbon 10" tractor/friction 12 months warranty.
Sakata SP5500 \$890
180CPS, NLQ, IBM graphics, italic, 3K buffer large ribbon, 15" tractor or friction, 12 month warranty.



- Super 5 EN1201 \$610
120 CPS 9X11 dot NQL W/switch, IBM graphic, 1K buffer 10" paper bit Image 480/1920/line, parallel O/P.
 - Super 5 EN1090 \$480
100CPS 9X11 same as EN1201 except without NLO/switch
- All prices subject to change due to exchange rate.

VERBATIM DISKETTE

- 5.25" DISKETTES
Valuelife S/S D/D \$30/box of 10
Valuelife D/S D/D \$36/box
Datallife S/S D/D \$36/box
Datallife D/S D/D \$45/box
Datallife D/S Q/D \$59/box
- 3.5" DISKETTES
Datallife S/S D/D \$75/box
Datallife D/S D/D \$95/box

DISKETTE STORAGE BOX

- Keylock 5.25" hinged small \$28
- Keylock 5.25" hinged large \$37
- Hinged 5.25" with staggered display \$46
- Keylock 3.5" hinged top \$36



RADIO CONTROL SWITCH for car alarm, garage, gate etc.

- Single channel with two keyring transmitters specification: \$129
- 12VDC 19MA power supply, relay o/p 10A rating, panic switch, indicator o/p, over 20 m range & 17,000 combination.
- Dual channel with one keyring \$169
- 305 MHz 80-100M range, 2058 code combination.

CAR ALARM AA83 \$73
Keyless auto alarm, flashing light, current sensing, both NO & NC, including bracket and wire.

CAR ALARM AA843 \$110
Same as AA832 plus facility to recharge battery.

QUARTZ LOCK ULTRASONIC DETECTOR \$46
Two separate trans. and rec'r, relay O/P, suit car alarm.

REMOTE CONTROL POOL ALARM PA-30 \$215
Sound alarm if someone drops into the pool, includes 240VAC remote receiver, cover 20' x 40' pool.

BIGI



BIGI RED LED DOT MATRIX SIGN \$1250
Programmable display sign with full size keyboard, measured 16 cm x 135 cm, char. run vertical or hor. 9 speed, flashing etc. 240VAC with battery back-up on memory, ideal for office, school, and information centre.

TOROIDAL TRANSFORMER

VA	PRICE	DUAL SECONDARY VOLTAGE										SINGLE	
		6	9	12	15	18	22	25	30	35	40	45	55 110/220/240
15	29.95
30	33.95
50	39.60
80	43.00
120	47.50
160	58.50
225	66.50
300	75.00
500	104.00
625	120.00

- AEM 4600 Modem \$150
- ETI 684 Modem Kit power supply ... \$43

COMPONENTS SPECIAL

- Eprom
2716 \$5.50
2732 \$7.00
2764 \$7.50
27128 \$12.50

- Modem IC
EF7910 \$28.50

- Memory IC
2114 1KX4 \$2.95
7117 2KX8 \$6.50
4164 64KX1 \$2.95
41256 256KX1 \$13.50

- Keyboard IC
AY 3-8910 \$11.50

- CPU'S
6502 CPU \$11.00
6522 VIA \$11.00
6802 CPU \$11.00
6821 PU \$ 8.90
6809 CPU \$16.00
Z80A CPU \$6.00
Z80A SIO \$11.50
Z80A PIO \$5.90
Z80A CTC \$6.00
Z80A DART \$12.90
Z80B CPU \$6.50

- IC Amplifier
TDA2003 10W car radio \$4.50
TDA2006 10W Audio amp \$4.50
TDA2030A 18W Hi-fi audio \$5.90
LM386 0.3W Amp 6V \$1.80
LM380 2W Amp 9-18V \$1.80
HY60 30W/8R W/Heatsink \$36.00
HY128 60W/8R W/Heatsink \$63.00
HY248 120W/8R W/Heatsink \$82.00
HY368 180W/8R W/Heatsink \$125.00
MOS128 60W/8R W/Heatsink \$122.00
MOS248 120W/8R W/Heatsink \$150.00
MOS360 180W/8R W/Heatsink \$228.00

- SPECIAL IC'S
MC13020 AM Stereo decode \$7.50
MN3001 BBD Echo effect \$12.50

- REMOTE CONTROL IC'S
SL480 Infra red preamp \$9.00
SL486 Infra red preamp \$9.50
SL490 32 Channel Transm. \$10.50
ML926/7 16 Channel Decode \$8.00
ML928/9 17 Chan. Decoder \$8.00

- CRYSTALS
2.4576 MHz \$3.90
3.579545 MHz \$3.90
4.0000 MHz \$3.90
14.31818 MHz \$5.90

- POWER TRANSISTORS
2N3055 NPN 100V 15A 117W ... \$1.30
MJ2955 PNP 100V 15A 117W ... \$1.30
MJE3055T NPN 90V 10A 90W \$1.20
MJ802 NPN 90V 30A 200W \$7.50
MJ4502 PNP 90V 30A 200W \$7.50
2SA1094 PNP 140V 12A 120W \$9.50
2SA2564 NPN 140V 12A 120W ... \$9.50
MJ15003 NPN 140V 5A 250W \$6.90
MJ15004 PNP 140V 5A 250W \$6.90
BUX80 NPN 800V 15A 100W ... \$6.90
2SC1413A NPN TV1500V 5A 50W ... \$9.50

UNDERSTUDY

— XP640 Programmer and XM520 Emulator

It's always satisfying to see a unit perform on a real job and even more pleasing when everything shapes up. This programmer and emulator proved themselves invaluable for this engineer's act.

RECENTLY, A PROJECT being designed in the ETI lab required some software development. The software is in machine code form, serving the dual functions of circuit hardware checking and circuit applications. It requires a lot of small, tedious subroutines to be written, burnt into the EPROM and plugged into the target system (the circuit you want to test) and tested. It very soon becomes a never ending battle of burning-erasing and re-burning of EPROMs. That might be OK for someone who has mega stock of EPROMs but the time investment is just too much for us.

A quick shop around found us the helpful XP640 EPROM programmer and XM512 ROM emulator from Elmeasco Instruments. The XP640 can be used as a stand alone programmer and is endowed with very powerful programming features. The XM512 Emulator could be viewed as a supporting device to enhance the facilities on the programmer maximally. They are both encased in lightweight aluminium conveniently ready to be carried around.

XP640 EPROM programmer

To start with, this XP640 EPROM programmer can do a lot more than just burn EPROMs. It can also burn and erase the recently introduced EEPROM and automatically check the correct insertion of the EPROM in the socket with 64K bytes of internal memory. The programmer incorporates a LED display for data and commands.

One handy design in this unit enables the user to hook up the video monitor to the programmer, thus allowing a much bigger portion of the memory in the system or multiple commands to be examined on the screen simultaneously.

The entire keyboard can be divided into four sections functionally: data entry, edit,

command and cursor control sections. To save space and cost, the editing and data entry keys are multiplexed together by a single function key. If you happen to be a poor engineer who has to key in machine code manually, these keys are a must.

The editing function allows the user to define an address within the 64K for the cursor to move to instantly. The user can define a block of memory of any size and do something to it later. The most common thing is to shift the data in that block of memory to another part of the memory. You can also copy it to another address, invert (complement) the data in a defined block, or fill the entire block with whatever data you like.

Apart from the block operations, the user can move the cursor with the 'up', 'down', 'left' and 'right' arrow keys to the start of data, replace it with something else, or delete it with automatic shifting of the following data to fill the 'hole'.

Having to insert a few bytes in the middle of a program after the entire thing has been entered is a real pain, unfortunately unavoidable. In this programmer, you are catered for. You simply move the cursor to the place where you want to insert and hit the insert key. A 'hole' is automatically generated for you in the memory with the rest of the following data shifted back one location. Hit the insert key again and two holes will be generated and the data you have to insert is simply keyed in.

The ability to handle 16-bit machine programming really puts the unit forward in the market. The 'split' command divides the internal RAM into two blocks as specified by the type of device selected. All data at even addresses is stored in the lower half of the block, and all odd address data is stored in the top half. The effect is that if 16-bit data had been loaded into the RAM (from the serial port), it

can be split so that two EPROMs can be programmed: one containing the data at even addresses, the other containing data at odd addresses. The 'shuffle' converses the split to interleave the data in the top half of the block with data in the lower half, that is, a 16-bit to 8-bit shuffle. On top of all these handy features, a specific data byte can be located with the 'search' command. The entire data entry and editing sections are protected while you are away for a coffee break if a 3-digit code has been entered using the 'lock' command. Further data editing can only be resumed if the keyboard is unlocked with that selected 3-digit code.

Command keys section

There are two ports (one serial RS232 and one Centronics) in the unit to allow communications to the external peripherals. The 15 keys in the command section control the ports, the programming sequence, the printing, menu of EPROM, emulation and a lot of checking during data transfer.

The keys that handle the programming sequence enable the user to check if the EPROM is blank, verifying that the correct program is burnt in, and calculating the check sum or a cyclic redundancy check on the entire program. Of all these, I have found the illegal bit check command is most useful. Very often, a corrupted EPROM or an EPROM which has not been erased properly will have some of the bits stay at logic 1. If these bits match with the corresponding machine code you are trying to burn in the EPROM, there is indeed no need to erase the EPROM again.

Ports

The 'port' key used in conjunction with the data entry keys, enables the user to

S. K. Hui

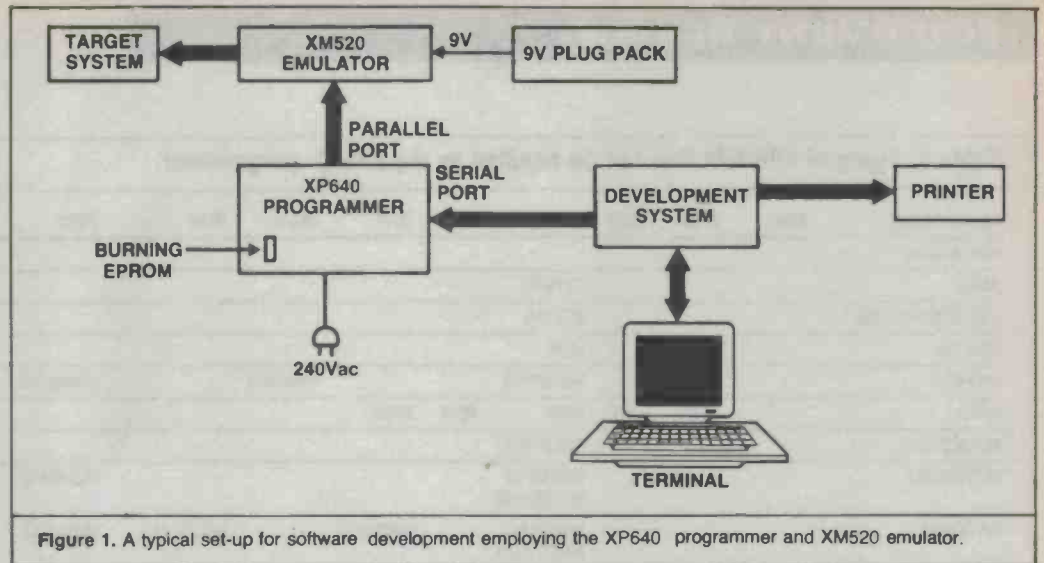

Figure 1. A typical set-up for software development employing the XP640 programmer and XM520 emulator.



EQUIPMENT REVIEW

Table 1. Types of EPROMs that can be handled by the XP640 programmer.

Device Menu	2508	2758A	2758B	2716	2815	2816	48016	9716	2532	2732	2732A	2564
Manufacturer												
AMD				2716DC						273DC	2732ADC	
EUROTECHNIQUE				ET2716						ET2732		
FUJITSU				8516						MBM2732	MBM2732A	
HITACHI				HN462716			HN48016		HN482532	HN482732		
INTEL		2758A	2758B	2716	2815	2816						
mitsubishi				M5L2716K						M5L2732K		
MOTOROLA				MCM2716 MCM27A16					MCM2532			
NATIONAL				MM2716 NMC27C16		NMC2816		NMC9716	NMC2532	NMC2732 NMC27C32		
NEC				UPD2716D						UPD2732D	UPD2732AD	
OKI				2716							2732A	
ROCKWELL						R5213				R87C32		
SEEQ												
SGS						2816A 5516A						
TEXAS INST	TMS2508								TMS2532	TMS2732		TMS2564
TOSHIBA										TMM2732D		
Device Menu	2764N	2764I	2764A	2764Q	27128N	27128I	27128A	27128Q	27256I	27256Q	27512I	
Manufacturer												
AMD	2764DC					27128DC			27256DC		27512DC	
EUROTECHNIQUE	ET2764											
FUJITSU					MBM2764 MBM27C64			MBM27128			MBM27C256	
HITACHI	HN27C64 HN482764					HN4827128						
INTEL	2764		2764A			27128			27256			
MITSUBISHI		M5L2764K										
MOTOROLA												
NATIONAL												
NEC	UPD2764D UPD27C64					UPD27128D						
OKI	MSM2764RS											
ROCKWELL	R2764 R87C64											
SEEQ		2764				27128						
SGS	M2764											
TEXAS INST	TMS2764											
TOSHIBA	TMM2764D					TMM27128D						

define the parameters required in both ports. In the RS232 serial port, the things needed are the number of bits for data, the stop bit, the kind of polarity, etc. In the parallel port, what's needed is information as to whether the bytes received/transmitted (which should be in binary, hexadecimal or ASCII etc) are user selectable. Once you have defined the format in the ports and other parameters in the system, they can be stored permanently even if the power of the whole machine is

turned off.

There are numerous different formats which can be set up in the serial port to enable the XP640 programmer to directly hook up to any development system, formats like Motorola Exorciser 'S' record, Intel Hex Data Format, GP Binary, Tektronix Hexadecimal, MOS Technology data format, Signetics Absolute Data Transmission format, DEC Binary etc.

A single 'serial in' key depressed will put the serial port in standby condition,

waiting for data to be sent over from the host. Checksum is automatically calculated at the end of the transmission and displayed on the screen. Data in the internal RAM of the programmer can be sent out too with a single 'serial out' key.

The serial port is so talented it can even be hooked up to a remote terminal, and with a single 'remote' key, the entire XP640 programmer is under the control of the terminal.

In conclusion, the machine is extremely

versatile with many little handy features built in. The only less congratulatory comments are for the \$1900 price and the 'rigid touch' keys used in the machine.

XM512 RAM/ROM emulator

So far, the programmer has only given programming capability and redundancy built in for emulation. To realise the emulation, another unit is needed. The XM512 emulator will cost you another \$600-\$700.

The machine has sockets on board for the memory to be easily expanded up to 64K bytes to match the memory size of the mother machine (XP640). The emulator has a CPU on board to mastermind the data transfer from the mother machine, shuffle data during 16-bit emulation, control the display, etc.

There are several arrays of switches on the bottom of the unit for the user to input parameters to the machine. You have to tell the machine the RAM chips on board are 2K byte or 8K byte each, the type of EPROM you are trying to emulate and the mode of operation required. The self-test mode is a rather useful feature in the machine. Anyone buying the unit can turn this mode on to find out instantly whether the machine is functioning or not.

Although the machine had been designed primarily for emulating ROMs, it can also be used to emulate RAM. The major difference between the two is that during the ROM emulation, the target system cannot write anything into the internal RAMs of the emulator, thus avoiding possible program corruption during the software development. The target system is free to write to the emulator during RAM emulation.

There is an optional line connecting to the reset of the target system. A download from the mother machine to the emulator will automatically reset your target system.

Functionally, it is better to divide the emulator and the programmer into two separate units. This arrangement has some advantages such as when the emulator is busy communicating with the target system, the programmer may be talking to a remote terminal, receiving a new program from the development system, or editing the data in its own internal RAM etc. The only drawback of this scheme is the extra bugs for the emulator.

However, with intelligence in the XP640 programmer control software, the 64K internal memory of the programmer could immediately 'emulate' the ROM/RAM in your target system. This architecture immediately precludes the above advantages offered to the scheme where separate units are used for programming and emulating, but does the latter approach justify the extra cost?

Australia's Top Motorcycle Monthly

TwoWheels

ON SALE AT YOUR NEWSAGENT EVERY MONTH

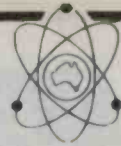

Disco World Pty. Ltd.

Showrooms:

300 Main Street, Lilydale
P.O. Box 509, Lilydale, 3140
Melb. Vic. (03) 735-0588
673 High Street, Preston
(03) 470 5822

AMPLIFIERS

ZPE Series II (600W) \$1750.00

DISCO MIXERS

Citronic SM 350 \$785.00

Arista with equaliser \$350.00

JUMBO STROBE

Scanner \$179.19

\$120.45

HELICOPTER

2 ARM Spinner \$238.00

4 ARM Spinner \$395.28

6 ARM Spinner \$452.00

UFO Spinner \$1698.55



PINSPOT

Par 36 \$52.75

Par 46 \$70.79



MIRROR BALLS

MB 008-8" \$44.64

MB 012 \$77.49

MB 014 \$112.25

MB 018 \$150.41

MB 020 \$181.10

SMOKE MACHINES

Great for Special Effects

Hand Held 240V \$352.00

Dynamite Smoke Machine

Has remote control lead to operate off-stage. We are so excited about this that full money back guarantee will be valid for 10 days from purchase date

Our own product \$1800.00

Fluid - 1 litre \$15.00

MIRROR BALL MOTORS

AC 240V \$35.50

Heavy Duty \$93.20

ROLLING LIGHTS

8 x 4515 lamps \$1450.00

AUDIO CHASER

(DW4LC4000) \$295.00

Musicolor and chaser all in one!

Our own product.

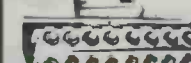

COSMO BALL

24 lamps \$1990.00

Half Ball rotary light

6 lamps \$428.74

LAMPS all colours, soft glass

No Warranty on Breakages

ES 240V 60W box of 25 \$75.00

BC 240V 40W box of 100 \$77.00

BC 240V 25W box of 100 \$75.00

Prices subject to change without notice.

Power Cords not included.

Trade Enquiries Welcome.

Send S.A.E. with 60 cents

postage for free price list.

Cut this out for 10% discount and post

to us with your order and money.

Valid till 31/1/86.

ETI READER SERVICE 118

DIGITAL SAMPLER

Part 1 The Inside Story

Lately there has been a new catch-phrase echoing around the music industry — 'digital sampling'. The myths surrounding this subject are many, and hopefully this series of articles will clear the haze a little.

Glen Thurecht &
Andrew Robb

NOWADAYS THE SOUND of sampling is appearing in everything from Top 40 hits to television advertisements. Commercial

samplers vary from complete keyboard oriented types, such as the Australian designed Fairlight Instrument, down to the more

basic version which has one memory, able to record and reproduce a single short length of sound. This ability to capture a 'real life sound' and store it away for later replay has been labelled as the ultimate musical tool. But, as with most things, sampling has its limitations too. The art of choosing the right sound to start with, and recording and fitting it into the storage available plays an important part in how useful the final sample will be.

To this end Part 1 of this project will firstly develop the theory behind digital sampling and go on to discuss the electronic techniques involved. The approach is general, keeping mathematical content to a minimum without neglecting important principles. A lot of what is presented is not only relevant to sampling but to general digital data acquisition systems as well. Naturally all this theory has to lead somewhere — on to the construction of The Sampler, of course!

The circuit is basically an analogue-to-digital-to-analogue converter with a bit of memory in between. Playback of the recorded sound can be triggered by almost any voltage source. You can hook up your computer, synthesiser or any sort of pickup. We have been using the prototype mainly for drum or percussion type sounds, triggered by belting a rubber pad/mic set-up with a pair of drumsticks. Recording can be initiated either manually or by the actual sound being recorded. The sounds, once recorded, can remain in memory even after power-down. This facilitates portability, which will be needed if the unit is to be used in a band situation.

Along with straight reproduction the stored sound can be clocked out of memory at different speeds, giving a variable pitch effect. Also, as a bonus, the unit can be used for pseudo reverberation or as a simple digital delay. What more could you ask for?

The final part of this series will present the different methods of recording sounds and problems that may be encountered. This is a part of the sampling process that is often neglected. It calls for a bit more technical talk in order to understand cause and solution.

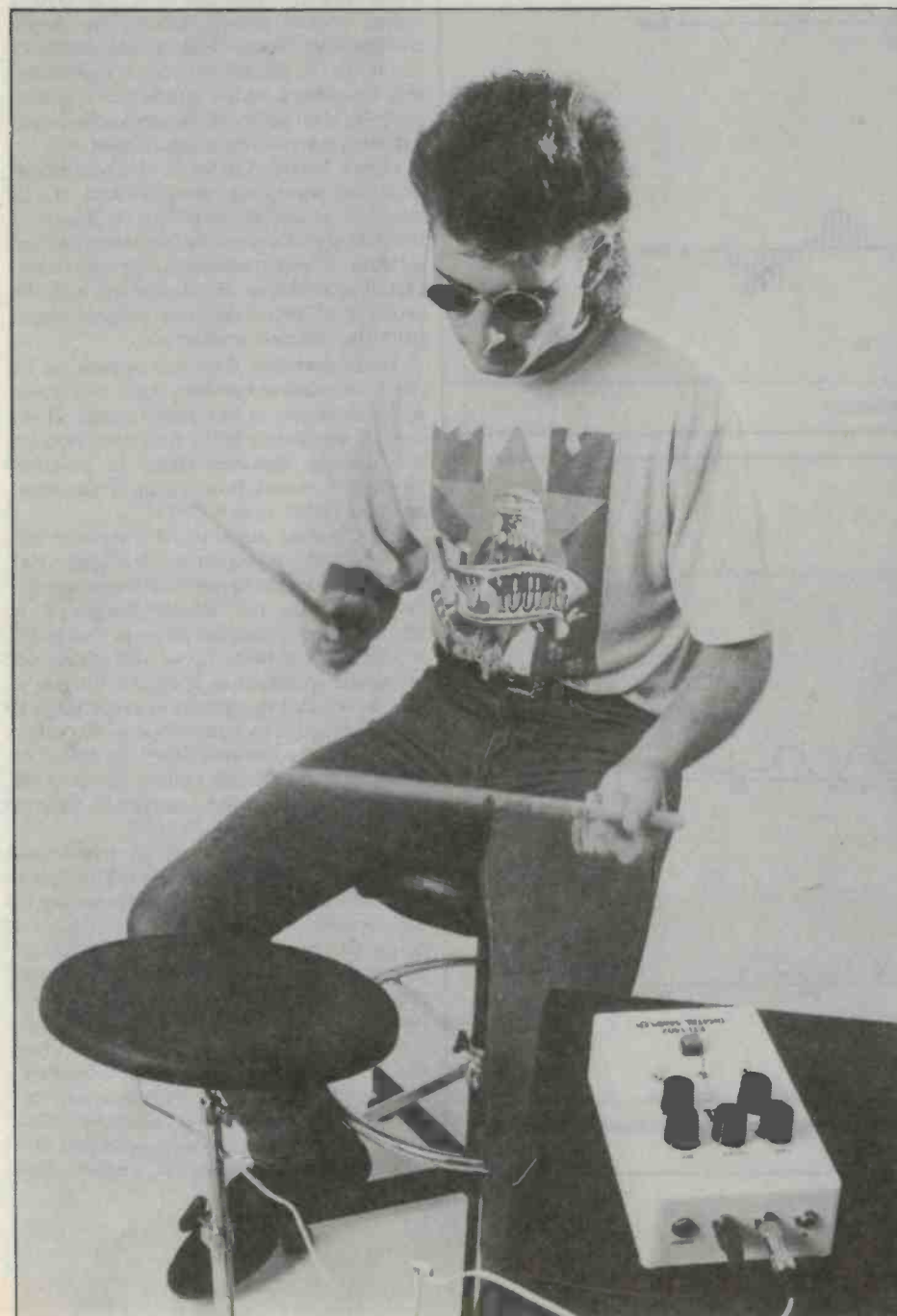

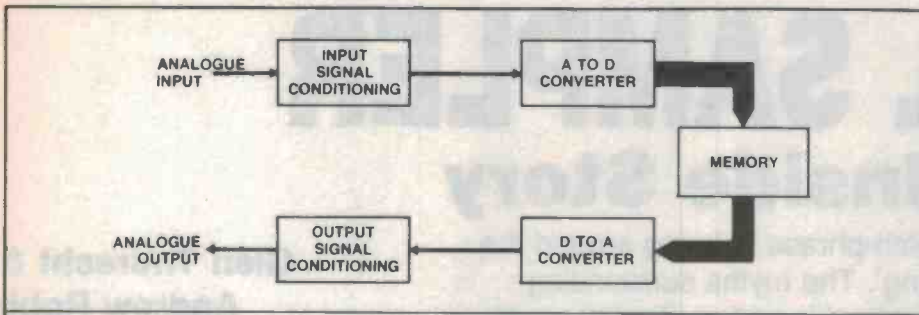

Figure 1. Simplified sampling system block diagram.

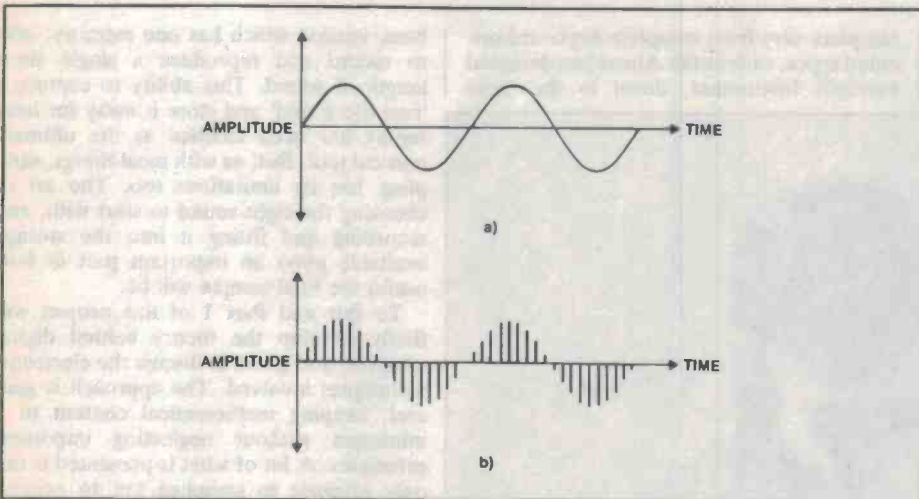

Figure 2(a). Analogue waveform; and (b) sampled waveform.

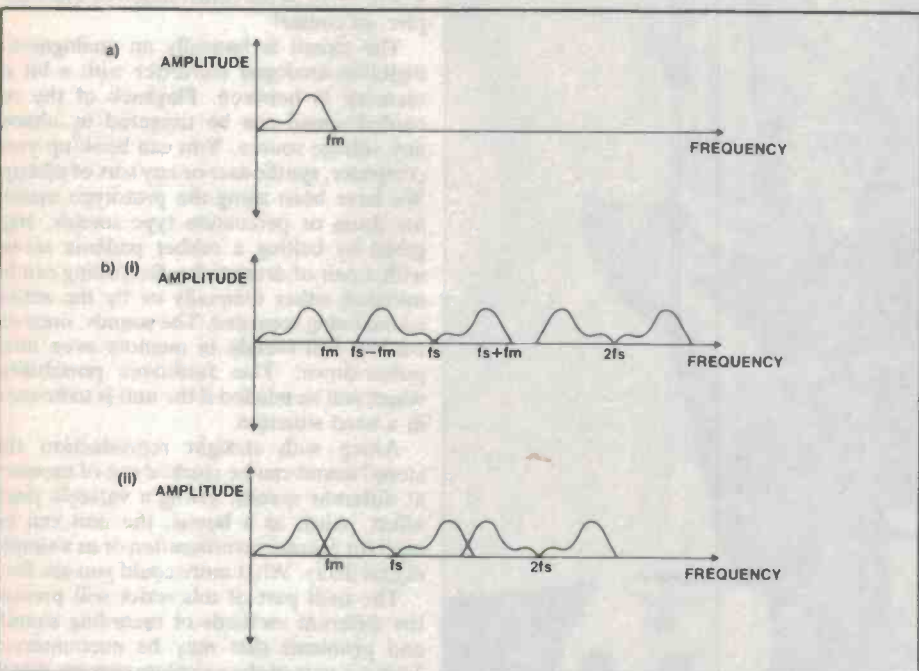

Figure 3(a). The spectrum of the original system; (b) the spectra of pulses representing sample values of the original signal at (i) $f_s > 2f_m$ and (ii) $f_s < 2f_m$.

Theory

Sampling is the process of converting a continuous analogue signal to digital form ideal for processing, transmission, or in our case, storage. In order to understand the steps involved in this process, we can divide a sampling system into a number of blocks as shown in Figure 1. The block diagram has five main sections. Firstly, signal conditioning converts the analogue input into a form which is readily presented to the analogue-to-digital converter (ADC) for conversion to a representative digital signal. This digital signal is then stored in memory so that the representation of the input may be recalled at any time. When the sampled signal is to be replayed it is the job of the digital-to-analogue converter (DAC) to change the signal back into analogue form. The DAC's output is then passed through the output conditioning block. This section removes any noise (ie, clock frequency components) that have been added during the sampling process. If all goes well the analogue output will be a copy of the original input.

Figure 2 shows the result of a continuous analogue waveform being looked at, or sampled, at discrete intervals. At this point the discrete values can be converted to digital form, stored in memory, and then reconverted to analogue. So we are left with the problem of recovering our original signal from the sampled waveform.

There certainly does not appear to be much correlation between these two waveforms as shown in the time domain. However, if we operate in the frequency domain the solution becomes clear. In practical terms this means hooking up a spectrum analyser rather than a CRO.

Let's assume our original waveform has an amplitude spectrum as in Figure 3(a) with its highest component at frequency f_m . Now providing our sample frequency, f_s (the number of samples taken per second), is greater than twice f_m we will obtain an amplitude spectrum as in Figure 3(b). It is easy to see that the spectrum in the range 0 to f_m is exactly the same shape as the original. So, using a low-pass filter, the cut-off of which is at f_m , we can remove all the high frequency content and completely recover the original waveform. Simple!

Two important assumptions have been made; firstly, the original waveform must be band-limited to a maximum frequency f_m and secondly, the sampling frequency must be greater than or equal to $2f_m$. In formal jargon these criteria form the Nyquist sampling theorem where the minimum sampling frequency is called the Nyquist frequency.

Now, what happens if we don't obey these rules? The resulting spectral overlap, as shown in Figure 3(bii) will cause any frequency components above $f_s/2$ to be effectively reflected to a frequency below $f_s/2$ consequently corrupting the output. This

phenomenon is known as *aliasing*.

So now we know how fast we need to sample in order to completely recover the original signal. The second parameter of interest is the time available to take each sample without error, known as the *aperture time*. Think of taking a photo of a moving object. If the shutter is held open too long the object will have moved sufficiently to cause a blurred image. In the same way, if we try and sample a waveform for too long, it may change enough to cause an error in the digitised result. The maximum time available to sample without error will determine the system aperture time. We can relate this more formally in terms of the resolution. If our digital system is using n bits and the maximum input frequency is f Hz, then the system aperture time is defined as:

$$T_{sa} = \frac{1}{(2^n - 1) 2\pi f}$$

So much for the theory. Let's now look at the electronic implementation of the block diagram in Figure 1.

Input signal conditioning

Surprisingly this is the most complicated and least understood section within a sampling system, though it really only has one task. This is to present the input signal to the ADC in a form which will best utilise its performance and will not cause errors in the conversion process. For the best results we must use the full dynamic range of the converter. The dynamic range is the ratio of the smallest signal which can be converted, to that of the largest. This idea is similar to that used when you set up the recording levels on a tape recorder. For best sound quality and lowest noise the needles on the VU meters should average around the 0 dB mark and occasionally peak into the red. In digital conversion this means that the largest input signal amplitude should be converted to the maximum digital representation. To achieve this the input must be amplified (or given gain). For example, if the input is a microphone with a maximum amplitude of 100 mV and the ADC requires 5 volts as its maximum signal then the gain required is:

$$\begin{aligned} \text{Gain} &= \frac{\text{maximum ADC input}}{\text{maximum signal input}} \\ &= \frac{5}{100 \times 10^{-3}} \\ &= 50 \end{aligned}$$

When an analogue signal is sampled digitally there is always an error associated with it. This is illustrated in Figure 5. The shaded areas are the errors obtained in the digital sampling process. The effect of these random quantisation errors on the output of the sampling system is noise or hiss. It is important to note, however, that the noise is

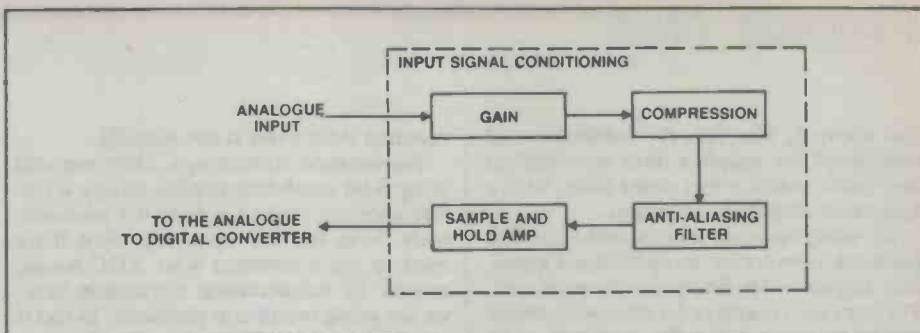

Figure 4. Steps that can be taken to prepare the input signal for the ADC.

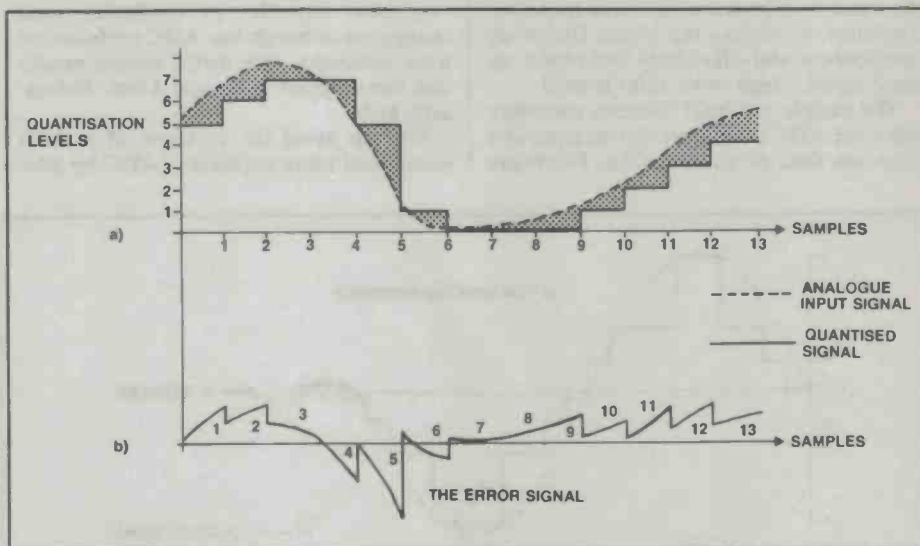

Figure 5(a). The analogue signal and the resultant quantised or digitised signal; (b) the error signal which is the analogue signal minus the quantised signal.

only present when a signal is being sampled so that if there is no signal present there will be no quantisation noise.

There are two ways to reduce these errors. The first is to increase the number of digital codes that the ADC can convert the signal into. For instance, an 8-bit ADC has 2^8 or 256 different digital codes whereas a 12-bit ADC has 2^{12} or 4096. Obviously the error that will be obtained with 12-bit conversion will be much lower, and hence quantisation noise is reduced. This ADC conversion system is called uniform encoding since each quantisation level is equal sized.

The second method of reducing the noise is to use non-uniform encoding. This technique relies on the fact that noise is only heard when the proportion of the noise to that of the signal is large. Therefore if the signal has a large amplitude, the noise can also be quite large and still not be heard since the signal will be swamping it. However for small amplitude signals the noise will become much more apparent because the ratio between the signal and the noise (signal-to-noise ratio!) becomes smaller. Figure 6 shows the difference between the two methods.

As can be seen, more of the quantisation levels are contained where they are needed

most — at low levels. Since the quantisation noise depends on the size of the steps taken, the noise is reduced at low levels.

Non-uniform encoding has usually been achieved by compressing the dynamic range of the signal before it is applied to a uniform encoding ADC and then expanding it back at the output of the DAC. However non-uniform encoding ADCs and non-uniform decoding DACs are becoming much more readily available and cheaper. This method eliminates any noise added to the system by an expander and also reduces design effort.

The next section within the input signal conditioning clock is the anti-aliasing filter. As already explained aliasing is the corrupted output signal that occurs if the input is not band-limited correctly. To band-limit a signal in the range of 0 Hz to f_m Hz a low pass filter is used. Ideally this filter will attenuate all frequencies above f_m Hz infinitely while still passing any frequencies below with no attenuation. In practice this is never achieved since no known method has been devised for building a filter with this response. However filters with sharp cut-off frequencies can be fabricated.

A simple passive RC filter has the response as shown in Figure 7. It has a low pass frequency response the amplitude of which falls by 6 dB per octave for frequen-

Project 1402

cies above f_m Hz. This RC combination is considered the simplest filter arrangement and hence called a first order filter, with a first order amplitude response.

By using resistors and capacitors in the feedback network of an operational amplifier, higher order filters can be produced. For instance a fourth order filter will attenuate frequencies above the cut-off by four times 6 dB/octave, that is, 24 dB/octave. This means that the higher order the filter the more it approaches the ideal response. Therefore to remove the higher frequency components and effectively band-limit an input signal a high order filter is used.

The sample and hold becomes necessary when the ADC cannot convert an input in a time less than or equal to T_{sa} . For many

common ADCs this is not possible.

For instance, converting a 2 kHz sinusoid using 8-bit resolution implies having a system aperture time of around 0.3 microseconds (from the T_{sa} equation). Now if we want to use a common 8-bit ADC having around 10 microseconds conversion time, we are going to run into problems. In fact if we did use this ADC it would effectively force T_{sa} up to 10 microseconds. The above relationship must still hold, meaning the only other variable, the resolution, must change; so although the ADC performs an 8-bit conversion, the actual system resolution has dropped to around 3 bits. Not exactly hi-fi!

We can avoid the purchase of a much faster (and more expensive) ADC by add-

ing the sample and hold to our system. We need something that can sample the input signal quickly enough to satisfy the system aperture time and then hold the resulting sample long enough for the slower ADC to convert.

Analogue-to-digital converter

The ADC has the job of forming some representation of the input signal in a digital format. Depending on the required bandwidth of the system the conversion time of the ADC can be anything between 100 μ s to 15 μ s when sampling an audio signal.

There exist three main techniques in use for audio sampling. These are: binary conversion, delta conversion, and predictive (or adaptive) delta conversion. Binary conversion is the method most commonly and traditionally used and provides an output which is a binary word equivalent of the input signal level. This means that if you use an 8-bit converter then you will need to store 8 bits in the memory. This is not the most efficient method for storing information needed to reconstruct the signal. Delta conversion is a much more efficient method. It uses a system which only checks to see if the signal amplitude is higher or lower than the last time a conversion was made. In other words, delta conversion produces a 1-bit code for the input signal and relies on past information to do the reconstruction. This would seem to represent an eight times saving in the amount of memory needed to store the same information. It turns out that in order to faithfully reproduce a high level transient, even within a band-limited signal, a much higher sampling rate must be maintained so that the converter may track the change.

A simple delta conversion system is shown in Figure 8. This shows the way in which the output of the delta code DAC is built up on the past information of the delta code. The delta code DAC remembers and sums all previous conversion values.

Predictive delta conversion was developed in an attempt to reduce the sample rate in comparison to the standard delta method. This technique is somewhat similar to the non-uniform, or compression systems that have been discussed. It has only been recently developed and there are many variations on the following conversion algorithm.

When an input is applied the comparator gives information to the encoder to say whether it is greater or less than the previous value that the delta DAC holds. If the encoder gives the same binary value consecutively the delta DAC is told to double the quantisation step.

If the converter gives two values that are opposite in sign then the DAC halves its quantisation step. In this way the response of the delta converter to high level transients is greatly improved and hence the

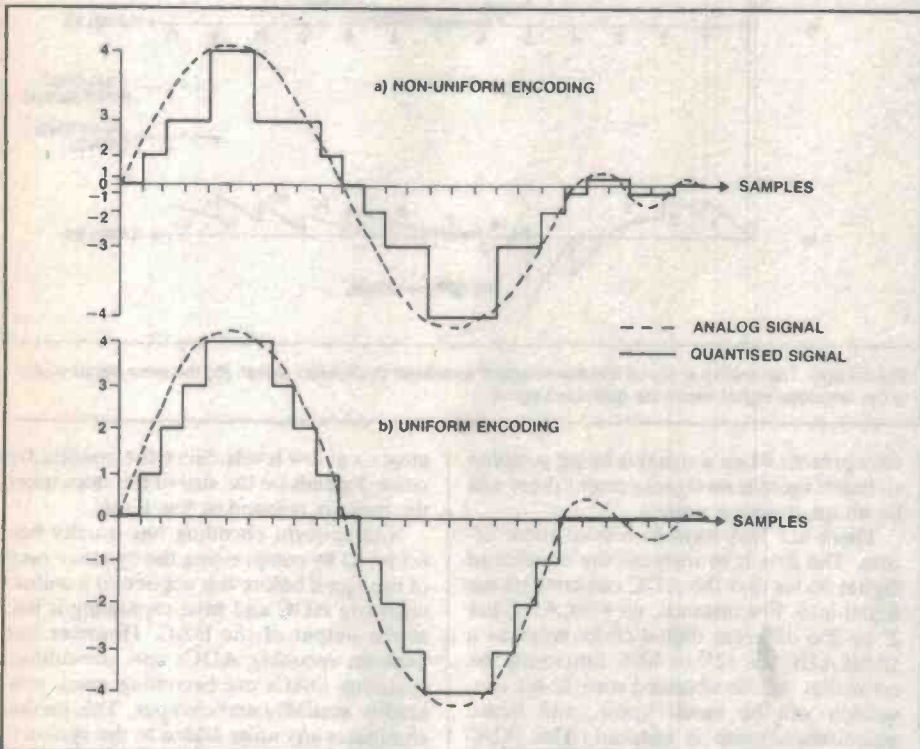

Figure 6. The difference between uniform and non-uniform encoding. Note that although the quantised waveform in (b) appears better for large amplitude signals, the signal information is completely lost for small amplitudes.

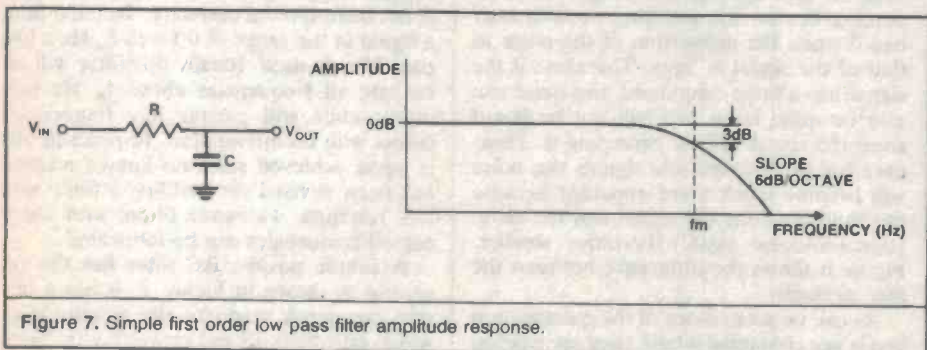

Figure 7. Simple first order low pass filter amplitude response.

sampling rate can be reduced. A comparison between these two techniques is shown in Figure 9.

Memory

The memory is needed to store all the digital samples for recall and conversion at the user's convenience. If you are sampling a signal it must be written into memory and hence must be of read/write form.

Three main methods are in use for the storage of digital samples. Firstly, there is silicon RAM which has the advantage of fast access, but the cost of storing a medium to large amount of samples is restrictive. Then there is bubble memory which is slower but still adequate for systems with limited bandwidth. It has the advantage of being able to store medium sized samples and of being non-volatile.

Finally there are disk storage systems. These suffer from being extremely slow and as such they are used in conjunction with silicon memory. The sound is stored permanently in the disk and then loaded into RAM when it is required for playback. In this way large libraries of sounds may be stored and the system is not limited to the size of the internal memory.

Digital-to-analogue converter

The only requirement in the DAC used in a sampling system is that it has a good linearity so as to reduce distortion of the signal.

Output signal conditioning

Output signal conditioning incorporates clock frequency filtering, output level adjustment, output impedance conversion, etc. Most of these functions will be determined by the application, however, the output filtering is always used.

The filter has to be high order so as to remove all the unwanted clock noise that is inevitably added in the sampling process. Whenever a constant tone is present in an otherwise random signal (such as a voice) it is very noticeable. Hence the filter should be fourth order or above. If the sampling frequency is above hearing (ie, around 20 kHz) then the ear will naturally remove a lot of the clock noise itself. But for low bandwidth systems, there is no other recourse. If you are sampling at the Nyquist frequency then the amount of attenuation of clock frequency is 6 dB/order of the filter. For example a fourth order filter will attenuate the clock noise by 24 dB. Of course if you are sampling above the Nyquist rate, as is normal, the attenuation will increase.

Finally, if a compressor is used in the input conditioning, an expander must be placed here to convert the signal back to its original dynamic range.

Project specifications

Obviously the choice of specifications boils down to what the sampler is actually

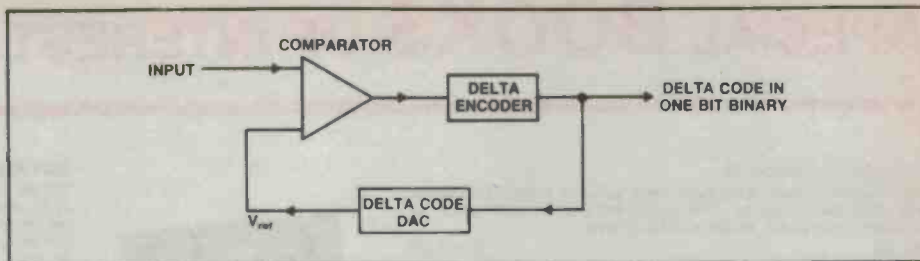

Figure 8. Block diagram for a delta conversion system. Note that the DAC must have knowledge of past conversions in order to produce V_{ref} .

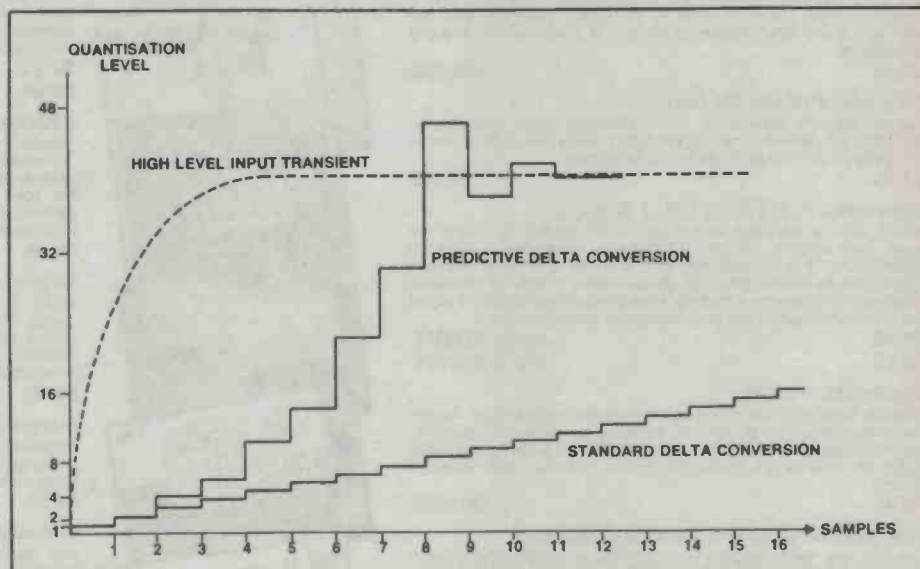

Figure 9. The response to fast changing inputs is much better for predictive delta conversions.

being used for. We want something with a decent storage time rather than outstanding resolution or bandwidth.

Keeping in mind the trade off of this practicality versus cost and complexity, a usable storage time of $\frac{1}{2}$ second, a signal bandwidth of 4 kHz and 8-bit resolution have been chosen. These should enable more than adequate operation for the recording of percussive style noises.

To calculate how much memory is needed we go back to the sampling theorem. A signal of bandwidth 4 kHz requires a minimum sampling rate of 8 kHz. In other words 8000 samples per second. Hence in order to store $\frac{1}{2}$ second of sound we will need to store 4000 samples, ie, we will need around 4 kilobytes of RAM.

Back to the maths again. Knowing we will have 8-bit resolution and a maximum input frequency of 4 kHz means the system aperture time can be calculated. This comes to about 160 nanoseconds. Fortunately the hassle of including a seemingly necessary sample and hold amplifier is avoided because the project utilises a special high speed ADC with a built-in sample and hold function. In fact although the actual conversion time is around 2 microseconds, the ADC has an effective aperture time of 100 nanoseconds.

Whereas cost may have limited the specs so far, the filter design is not so restricted.

The front end or anti-aliasing filter is fourth order, providing a good 24 dB attenuation at the Nyquist frequency. Similarly, in order to almost completely remove the annoying clock noise usually associated with such a system, a sixth order clock rejection filter is used. This provides about 36 dB rejection at the Nyquist clock frequency.

One unique feature of the sampler is its triggering arrangements. In addition to the internal switch, external high and low level trigger inputs are provided. High level accommodates either an open/closed switch or any sized voltage pulse. Low level enables triggering off the actual input signal. This is ideal for recording transient sounds such as your favourite crystal glass dropped on a brick. Low level mode also enables the use of the rubber pad/drumstick option, for those feeling more aggressive.

In order to save that precious ring of crystal when power is off, the unit has a battery back-up system which maintains power on the memories for several months. On top of that, the inclusion of a large capacitor enables any really nice sounds to be held even when the battery is changed.

Apart from straightforward sampling, a nice little twist in the design enables delay, or echo, and reverberation effects. That completes the formal part. Next issue we'll get into the circuit proper and start building!

SPECIAL BOOKS OF INTEREST...

Circuits Cookbook /5

More than 200 circuit and design ideas covering Alarms, Converters, Electronic Music, Games, Test Equipment and 18 other topics for engineers, technicians, students and hobbyists.

\$3.95 E0075E

Australian Scanner's World

There's a whole world beyond 'the shortwaves' — The communications channels scattered from 30 MHz upwards accessible with a VHF/UHF scanner. This is an introduction to that world with articles on scanning and scanners, how to build and erect suitable antennas, and a computer-sorted listing of services throughout Australia and NZ; beacons are also listed. Includes a roundup of scanners, antennas and accessories.

\$5.95 N0283E

Electronic Projects for Cars

Selected projects detail a car alarm, reversing alarm, fuel monitor, thermatic fan controller, twin-range tachometer, expanded-scale ammeter and many more. Includes ideas for experimenters.

\$4.95 D0216E

Electronics — It's Easy Vol. 1 & Vol. 2

Written for the intelligent layman as an introduction to electronics theory and methods. Volume 1 discusses electronics systems in general: What they do, how they do it, and how a complex electronic system can be broken down into fundamentals. Volume 2 introduces digital system theory and discusses the practical application to digital instruments, computers and peripherals, and oscilloscopes.

\$5.95 Vol. 1 A0001E

\$5.95 Vol. 2 A0002E

Electronics & Music

Explains the application of electronics to music reproduction. Articles cover the reinforcing of acoustic instruments, multitrack recording, graphic equalisers and microphone placement techniques plus other topics as well as an effects handbook. Includes seven selected projects.

\$5.95 G0125E

How to Build Gold and Treasure Detectors

Tells you how metal detectors work and how to construct the different types of detectors: discriminating, BFO, induction-balance and a professional deep-seeking unit.

\$3.95 C0033E

Computer Projects Vol. 1

Will let you construct ETI's Little Big Board Computer, an all-year clock for microcomputers, a direct-connect modem, a PPI-based EPROM programmer, a cheap menu-driven expansion for the Microbee and many other projects.

\$6.50 J0278E

Microbee Hacker's Handbook

Will tell you how to get more from the Bee's graphics capabilities, set up for telecommunications, play music, build a joystick and light pen, get cheap hard copy, expand your 16K Bee to 32K, and more. Also lists contacts for all known Microbee user groups.

\$6.50 J0291E

ETI Circuit Techniques Vol. 1 & Vol. 2

The how, what, which, where and how much anthology of electronic components, circuits and techniques. Volume 1 covers op-amps, 555 timer applications, CMOS, VFETs, power MOSFETs, designing with diodes and more. Volume 2 covers remote control systems, experimenting with ultrasonics, transistor arrays, junction FETs and more plus a 16-page circuit source guide.

\$4.95 Vol. 1 E0076E

\$4.95 Vol. 2 D0077E

Microbee Assembly Language Programming

Intended for Microbee owners who have become reasonably competent at programming in BASIC and are now ready to move on to assembly language. In spite of starting at square one, by the end of the book you should be able to write your own games and mathematical programs, get sound effects, and drive a printer — all at much faster speeds than the BASIC equivalents.

\$9.95 K0015E

Buying a Computer

Written by those who have already suffered the trauma of computer buying, it provides the information necessary to compare and evaluate various brands for various applications. The book is divided into Personal, Business and Portable Computers with a background Introduction and includes a Club File and Glossary.

\$4.50 H0010E

Bumper Book of Programs

Programs for the beginner, programs for the advanced, technical programs and games programs, programs from kids, programs for Apple, Commodore, Sinclair, Microbee and others ... PROGRAMS!

\$4.50 K0018E

Computers in Education

Both original and previously published articles have been drawn together as a guide for parents and teachers to approaching this new aspect of learning. Topics covered include choosing computers for high school and primary, a survey of courseware, girls and computers, computer administration, and what the kids think about it all.

\$4.95 H0013E

Start Computing

Edited by a bloke who knew less about computers than just about anybody when he started, but he learned and put together a solid introduction to computers and computing. The articles cover everything from Care and Feeding — Of the computer, of course to Databases — What they are and how you can use them. Written in English! Hardware: Isn't that the stuff from Mitre 10?

\$4.95 H0022E

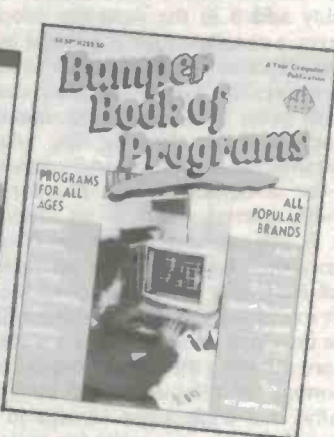
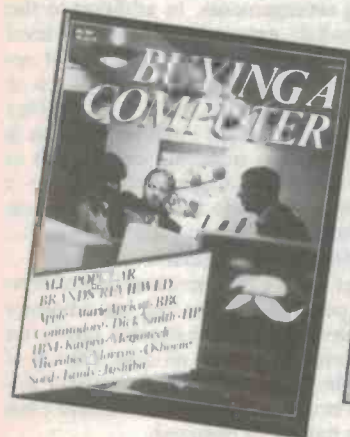

Order today — Return the Freepost reply card to:

Federal Marketing Book Sales
PO Box 227, Waterloo 2017, NSW
Tel: (02)663-9999 Tlx: AA74488



HOOK UP WIRE

Cat. No.	Description	1-9	10+
W11251	13/12 TND BLK	\$3.50	\$3.00
W11252	13/12 TLD BROWN		
W11253	13/12 TLD ORANGE		
W11254	13/12 TLD YELLOW		
W11255	13/12 TLD GREEN		
W11256	13/12 TLD BLUE		
W11257	13/12 TLD WHITE		

PRICES PER 100 METRE ROLL

Plus 20% tax where applicable

Cat. No.	Description	1-9	10+
W11260	14/20 RED	\$9.00	\$7.00
W11261	14/20 BLACK		
W11265	14/20 BLUE		
W11268	14/20 WHITE		

PRICES PER 100 METRE ROLL

Plus 20% tax where applicable

Cat. No.	Description	1-9	10+
W11270	24/20 RED	\$11.00	\$10.00
W11272	24/20 BLACK		
W11274	24/20 GREEN		

PRICES PER 100 METRE ROLL

Plus 20% tax where applicable

Cat. No.	Description	1-9	10+
W11280	32/2 BROWN	\$12.00	\$11.00
W11282	32/2 BLUE		

PRICES PER 100 METRE ROLL

Plus 20% tax where applicable



TRANSISTORS

Desc.	10-99	100+	Desc.	10-99	100+
25J49	4.50	4.30	25K134	4.50	4.30
PN2222A	.10	.08	PN2907A	.10	.08
PN3463	.15	.13	PN3565	.12	.11
PN3566	.15	.13	PN3567	.10	.08
PN3569	.18	.16	PN3639	.18	.16
PN3640	.18	.16	PN3641	.10	.08
PN3642	.10	.08	PN3643	.10	.08
PN3644	.15	.13	PN3645	.15	.13
PN4250A	.15	.13	PN4355	.16	.14
PN4356	.16	.14	MPSA42	.23	.20
MPSA43	.23	.20	MPSA55	.15	.14
MPSA56	.15	.14	MPSA92	.22	.20
MPSA93	.22	.20	SU1410	.85	.75
BU126	1.50	1.25	BUX80	2.50	2.20
BU208	2.50	2.20	2SD350	2.75	2.40
BU326	1.95	1.70			

Plus 30% tax where applicable



HORN SPEAKERS

Cat. No.	Description	1-99	100+
C12010	5" Plastic 10W Max	4.80	4.70
C12015	5" Metal 10W Max	4.70	4.60
C12012	12V Siren	8.50	8.00

Plus 20% tax where applicable

IC's GALORE!

	1-9	10+	100+	250+
8035	3.90	3.70	3.50	3.00
8085	4.00	3.90	3.50	3.00
8088	19.00	18.00	15.00	14.00
8155	3.90	3.75	3.50	3.00
8156	3.50	3.30	2.90	2.50
8212	1.90	1.70	1.50	1.00
8224	2.40	2.00	1.90	1.50
8226	1.90	1.70	1.50	1.00
8237A	35.00	31.00		
8253	3.90	3.70	3.50	3.00
8255	4.00	3.50	2.50	2.00
8257	3.90	3.50	3.00	2.50
8259	3.90	3.50	3.00	2.70
8237A	35.00	31.00		
8279	3.90	3.50	3.00	2.70

Plus 20% tax where applicable



MEMORY

"Check for the latest memory prices!"

	10-99	100+	1000+	10K+
4164-15P	\$ 2.50	\$ 2.00	\$ 1.75	\$ 1.60
41256	\$ 6.00	\$ 5.00	\$ 4.50	\$ 4.00
6116P-3	\$ 3.00	\$ 2.90	\$ 2.20	\$ 2.00
2716	\$ 4.90	\$ 4.50	\$ 4.25	\$ 4.00
27128	\$ 5.00	\$ 4.50	\$ 4.00	\$ 3.50
2532	\$ 7.50	\$ 6.50	\$ 6.40	\$ 6.30
2732	\$ 6.50	\$ 6.10	\$ 5.90	\$ 5.50
27256	\$29.00	\$27.00	\$22.00	\$19.00
6264	\$ 5.50	\$ 5.00	\$ 4.50	\$ 4.00
2764	\$ 6.00	\$ 5.00	\$ 4.50	\$ 4.00

Plus 20% tax where applicable

BRIDGES

	10+	100+	1000+	10K+
6A 400V	1.00	0.80	0.75	0.69
W02	0.24	0.23	0.20	0.18
W04	0.25	0.24	0.21	0.19

NEW MDA3504 BRIDGE!

	10+	100+	1000+	10K+
35A 400V	3.50	2.90	2.75	2.50

Plus 20% tax where applicable



TRANSFORMERS

Cat. No.	Descr.	1-99	100+	1000+
M12851	2851	2.50	2.25	1.90
	240V 12-6V CT 150mA			
M12155	2155	4.80	4.10	3.70
	240V 6-15V 1A tapped			
M12156	2156	6.35	6.15	5.95
	240V 6-15V 2A tapped			
M16672	6672	6.35	6.15	5.95
	240V 15-30V 1A tapped			

Plus 20% tax where applicable

NEW TRANSFORMER!

Cat. No.	Descr.	1-99	100+	250+
M12860	2860	3.00	2.50	2.30
	240V to 15V C.T. at 250mA			

Plus 20% tax where applicable

ELECTROLYTIC SINGLE ENDED PCB MOUNT

Cat. No.	Descr.	10+	100+	1,000+
R15405	0.47uF 63V	\$0.07	\$0.06	\$0.05
R15415	1uF 63V	\$0.07	\$0.06	\$0.05
R15422	2.2uF 25V	\$0.07	\$0.06	\$0.05
R15424	2.2uF 50V	\$0.06	\$0.05	\$0.04
R16425	2.2uF 63V	\$0.07	\$0.06	\$0.05
R15432	3.3uF 25V	\$0.07	\$0.06	\$0.05
R15435	3.3uF 63V	\$0.07	\$0.06	\$0.05
R15442	4.7uF 25V	\$0.07	\$0.06	\$0.05
R15443	4.7uF 35V	\$0.08	\$0.07	\$0.06
R15445	4.7uF 63V	\$0.07	\$0.06	\$0.05
R15461	10uF 16V	\$0.07	\$0.06	\$0.05
R15462	10uF 25V	\$0.07	\$0.06	\$0.05
R15463	10uF 35V	\$0.07	\$0.06	\$0.05
R15465	10uF 63V	\$0.07	\$0.06	\$0.05
R15481	22uF 16V	\$0.07	\$0.06	\$0.05
R15482	22uF 25V	\$0.08	\$0.06	\$0.05
R15483	22uF 35V	\$0.08	\$0.07	\$0.06
R15484	22uF 50V	\$0.09	\$0.08	\$0.07
R15502	25uF 25V	\$0.07	\$0.06	\$0.05
R15505	25uF 63V	\$0.10	\$0.08	\$0.07
R15512	33uF 25V	\$0.08	\$0.07	\$0.06
R15521	47uF 16V	\$0.09	\$0.08	\$0.07
R15522	47uF 25V	\$0.09	\$0.08	\$0.07
R15525	47uF 63V	\$0.10	\$0.09	\$0.08
R15531	100uF 16V	\$0.10	\$0.09	\$0.08
R15532	100uF 25V	\$0.08	\$0.07	\$0.06
R15533	100uF 35V	\$0.15	\$0.12	\$0.11
R15535	100uF 63V	\$0.24	\$0.22	\$0.20
R15541	220uF 16V	\$0.09	\$0.08	\$0.07
R15542	220uF 25V	\$0.14	\$0.12	\$0.11
R15543	220uF 35V	\$0.25	\$0.23	\$0.20
R15545	220uF 63V	\$0.26	\$0.24	\$0.22
R15552	330uF 25V	\$0.15	\$0.13	\$0.12
R15555	330uF 63V	\$0.34	\$0.30	\$0.28
R15561	470uF 16V	\$0.18	\$0.13	\$0.12
R15562	470uF 25V	\$0.23	\$0.20	\$0.18
R15563	470uF 35V	\$0.30	\$0.28	\$0.26
R15564	470uF 50V	\$0.00	\$0.00	\$0.00
R15565	470uF 63V	\$0.44	\$0.39	\$0.36
R15581	1000uF 16V	\$0.25	\$0.22	\$0.20
R15582	1000uF 25V	\$0.35	\$0.30	\$0.28
R15583	1000uF 35V	\$0.45	\$0.40	\$0.36
R15591	2200uF 16V	\$0.45	\$0.40	\$0.36
R15592	2200uF 25V	\$0.65	\$0.60	\$0.50
R15593	2200uF 35V	\$1.20	\$0.91	\$0.75
R15601	2500uF 16V	\$0.45	\$0.40	\$0.36
R15602	2500uF 25V	\$0.65	\$0.60	\$0.50

Plus 10% tax where applicable

VOLTAGE REGULATORS

	10+	100+	1000+
7805uC	.45	.44	.43
7805Kc	1.50	1.40	1.20
7812uC	.45	.44	.43
7815Kc	1.50	1.40	1.20
7818uC	.50	.49	.48
7818Kc	1.50	1.40	1.20
7905uC	.70	.60	.55
7912uC	.70	.60	.55
uA323Kc	4.50	3.90	3.75
78H12	7.00	6.00	5.90
78HGKc	7.50	6.50	6.00
79HGKc	16.50	16.00	14.00
78P05	11.50	11.00	10.50
78P12	14.00	13.50	13.00

Plus 20% tax where applicable

75 OHM COAX CABLE IN 100M ROLLS

Cat. No.	Description	1-4 rolls	5-9 rolls	10+ rolls
W11222	3C2V	18.00	17.00	16.00
W11224	5C2V	27.00	25.00	24.00

(5C2V WHITE OR BLACK)
LINE LOSS PER 100 FEET (33M 200MHZ)

Cat. No.	Description	1-9	10+
W11222	3C2V 6.2dB (Approx.)	\$11.00	\$10.50
W11224	5C2V 9.9dB (Approx.)	\$16.00	\$15.50

Plus 20% tax where applicable

AXIAL ELECTROLYTICS (DOUBLE ENDED)

Cat. No.	Description	10+	100+	1,000+
R15705	0.47uF 63V	\$0.12	\$0.10	\$0.09
R15715	1uF 63V	\$0.12	\$0.10	\$0.09
R15725	2.2uF 63V	\$0.12	\$0.10	\$0.09
R15742	4.7uF 25V	\$0.11	\$0.09	\$0.08
R15745	4.7uF 63V	\$0.11	\$0.09	\$0.08
R15761	10uF 16V	\$0.12	\$0.10	\$0.09
R15762	10uF 25V	\$0.13	\$0.12	\$0.11
R15765	10uF 63V	\$0.15	\$0.14	\$0.13
R15792	22uF 25V	\$0.13	\$0.12	\$0.11
R15794	22uF 50V	\$0.17	\$0.15	\$0.13
R15812	25uF 25V	\$0.13	\$0.12	\$0.11
R15815	25uF 63V	\$0.17	\$0.15	\$0.13
R15831	47uF 16V	\$0.16	\$0.13	\$0.12
R15832	47uF 25V	\$0.16	\$0.13	\$0.12
R15835	47uF 63V	\$0.22	\$0.19	\$0.17
R15841	100uF 16V	\$0.18	\$0.16	\$0.15
R15842	100uF 25V	\$0.18	\$0.16	\$0.15
R15845	100uF 63V	\$0.27	\$0.24	\$0.22
R15851	220uF 16V	\$0.17	\$0.15	\$0.14
R15852	220uF 25V	\$0.21	\$0.18	\$0.17
R15855	220uF 63V	\$0.50	\$0.46	\$0.40
R15871	470uF 16V	\$0.27	\$0.24	\$0.22
R15872	470uF 25V	\$0.29	\$0.27	\$0.25
R15873	470uF 35V	\$0.75	\$0.70	\$0.60
R15875	470uF 63V	\$0.75	\$0.70	\$0.65
R15885	1000uF 63V	\$0.60	\$0.58	\$0.55
R15891	1000uF 16V	\$0.39	\$0.35	\$0.30
R15892	1000uF 25V	\$0.45	\$0.40	\$0.38
R15893	1			

BIT PATTERN DETECTOR

Neale Hancock

Looking for a lost byte? Find it with the ETI-172! In applications where you are required to look for a particular byte of information in a serial or parallel data path, until now short of a logic analyser or a storage oscilloscope, there was not a lot to help you.

THIS PROJECT GIVES you a simple and economical way to detect and display specific bytes of data. It may be used on both parallel and serial data paths, or just on parallel data paths if you want to save yourself the cost of a UART.

Two methods used to indicate the presence of a specific data byte are possible, and shall be known affectionately as method 1 and method 2.

Method 1 is used to search a stream of data for a specific byte, then simultaneously illuminate an LED and send out a trigger pulse when the byte is detected. When this method is being used, the byte to be searched for is set on a bank of switches. Every byte which travels down the data path is compared with this byte and when the two are the same an LED illuminates.

Method 2 requires a single byte to be sent down the data path from a terminal or a bit pattern generator (the ETI-171 Arbitrary Waveform Generator can be used to perform this task). The bit pattern is set up on the switches and detected in the same way as in method 1; it is also displayed on the eight LEDs on the front panel.

When the bit pattern detector is used on serial data paths, either method 1 or 2 can be used to detect bytes of data. Method 1 is best used to determine whether a specific byte has reached the desired destination, and is convenient when troubleshooting RS232 links. In this case one can determine whether or not a peripheral is responding correctly to the data being sent to it.

Method 2 is best used to check whether

or not the serial link is transmitting data without errors. If there is an error in the transmitted data you can identify which bits are incorrect.

Parallel data paths are a common way of routing data around a pc board. Therefore the bit pattern detector is ideally suited to checking inputs and outputs on data and address buses (providing that they are no greater than 8 bits wide). In parallel mode, method 1 is used to trigger an event when the byte set by the programming switches occurs. This is ideal for microprocessor circuits when you need to trigger an interrupt line. Method 2 is best used for checking data flow through a circuit.

Circuit synopsis

The basic operation of the circuit is as follows. The incoming serial data is converted to TTL levels to enable it to be received in a form acceptable to the General Instruments AY-3-1015D universal asynchronous receiver-transmitter (or UART for short).

The UART primarily converts serial data into parallel data, it also removes start, stop and parity bits from the serial signal. The speed at which the UART runs is set by the baud rate generator.

The buffer is used to select between data from the UART or the parallel input, to be sent to the comparator. The comparator is used to compare the incoming data with the settings on the programming switches. When the incoming data is the same as the settings on the switches the 'pattern detected' LED is illuminated.

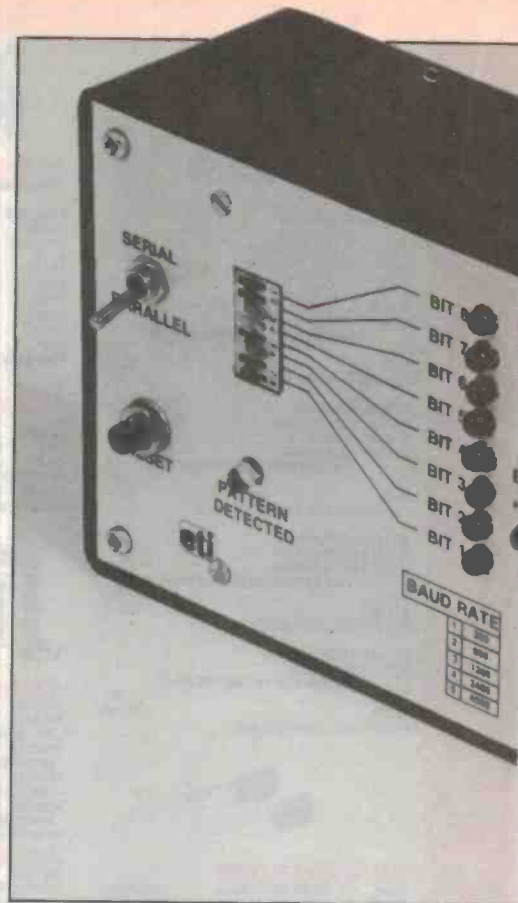

The buffered display shows the byte present on the data path on a row of LEDs. These LEDs are driven by non-inverting buffers to reduce loading.

Construction

If you only require the bit pattern detector to operate in parallel mode you can omit a number of components. These components are, IC1, IC2, IC8, Q1, D1, R1, R2, R3, R4, C1, C2, C3, C8, C9, C10, C11, LED1, LED2, SW1, SW2, SW3 and the 2.457 MHz crystal.

Before you commence construction examine the pc board for defects such as bridges and broken tracks. Also take note of the components which should be mounted on the copper side of the pc board. These components are marked in colour on the overlay. The reason for components being mounted there is because there is not enough clearance for them between the pc board and the front panel.

The resistors and capacitors should be mounted first. Take note of the orientation of the electrolytic capacitors C2 and C12, and remember that all the capacitors are mounted on the copper side of the pc board.

Next mount the diodes, but first check their orientation. Try to keep the spacing between LEDs 3 to 10 as consistent as possible, keeping in mind that they have to be aligned with the front panel. Also mount the three banks of DIP switches. The crystal, the regulator and the transistor can then be mounted on the copper side of the pc board.

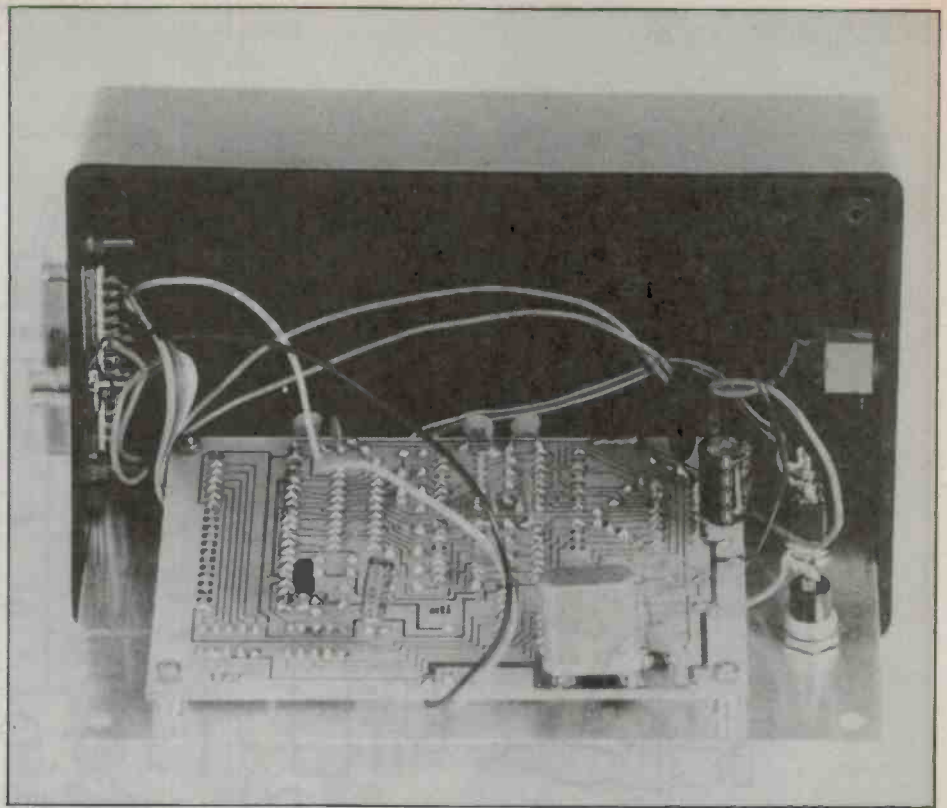

Rear view showing how the pc board is mounted behind the front panel.

Next mount the integrated circuits. All the ICs are CMOS except for IC1 which is NMOS so treat them all with respect. Remember NMOS and CMOS chips are static sensitive; they do not like having their legs touched, only pick them up by their ends.

When soldering in the integrated circuits, try not to overheat them by soldering rows of successive pins. This is especially important in the case of IC1 for which it is best to solder the pins from opposite ends, eg, pin 1 then pin 21, pin 2 then pin 22 etc. This prevents the chip from being excessively heated in one area and saves it from possible damage.

There are mercifully few flying leads to connect in this project, as the majority of the switches and all the LEDs are mounted on the pc board. Take note of the connections to the serial/parallel switch, the DB 25 socket and the 9 volt input socket. The DB 25 socket is also used to access the parallel data input. Table 1 shows the recommended connections. However, as RS232 connectors can be configured in different ways on different computers, check that these lines are not used in your particular case. If they are, you may get false data entering ICs 4 and 5. If some of the recommended lines are used, connect the parallel data input lines to unused pins on the connector.

To allow all the LEDs and DIP switches to poke neatly through the front panel requires some careful drilling. To assist in this check the drilling diagram. By accurately

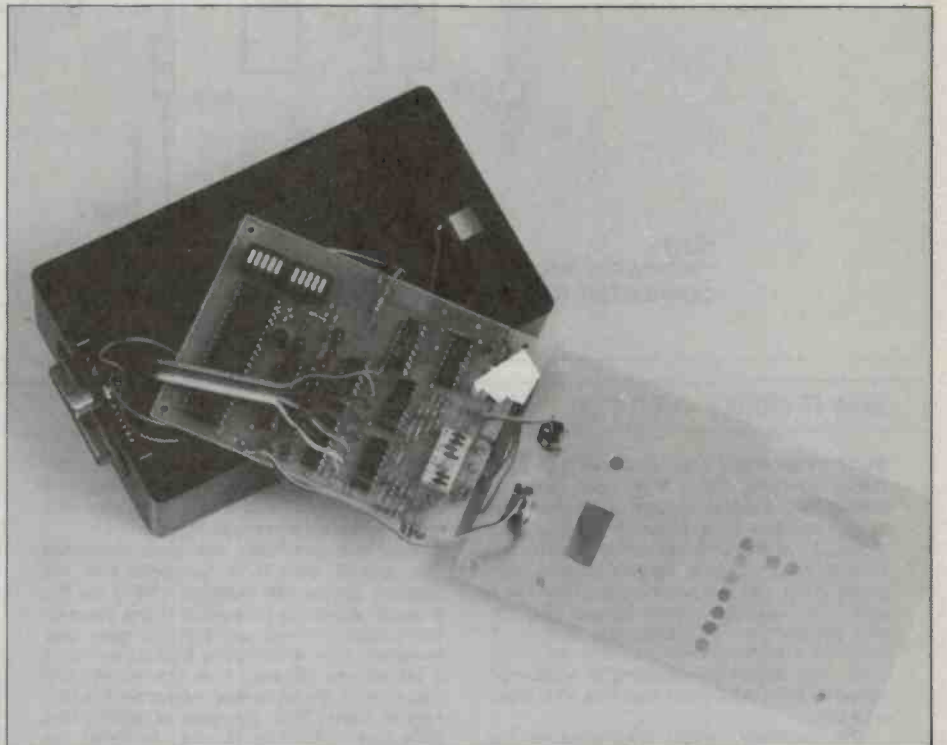

Placement of components on the pc board.

TABLE 1. DB 25 CONNECTIONS

Pin on DB 25 plug	14	15	16	17	18	19	21	22
Pad on pc board	1	2	3	4	5	6	7	8

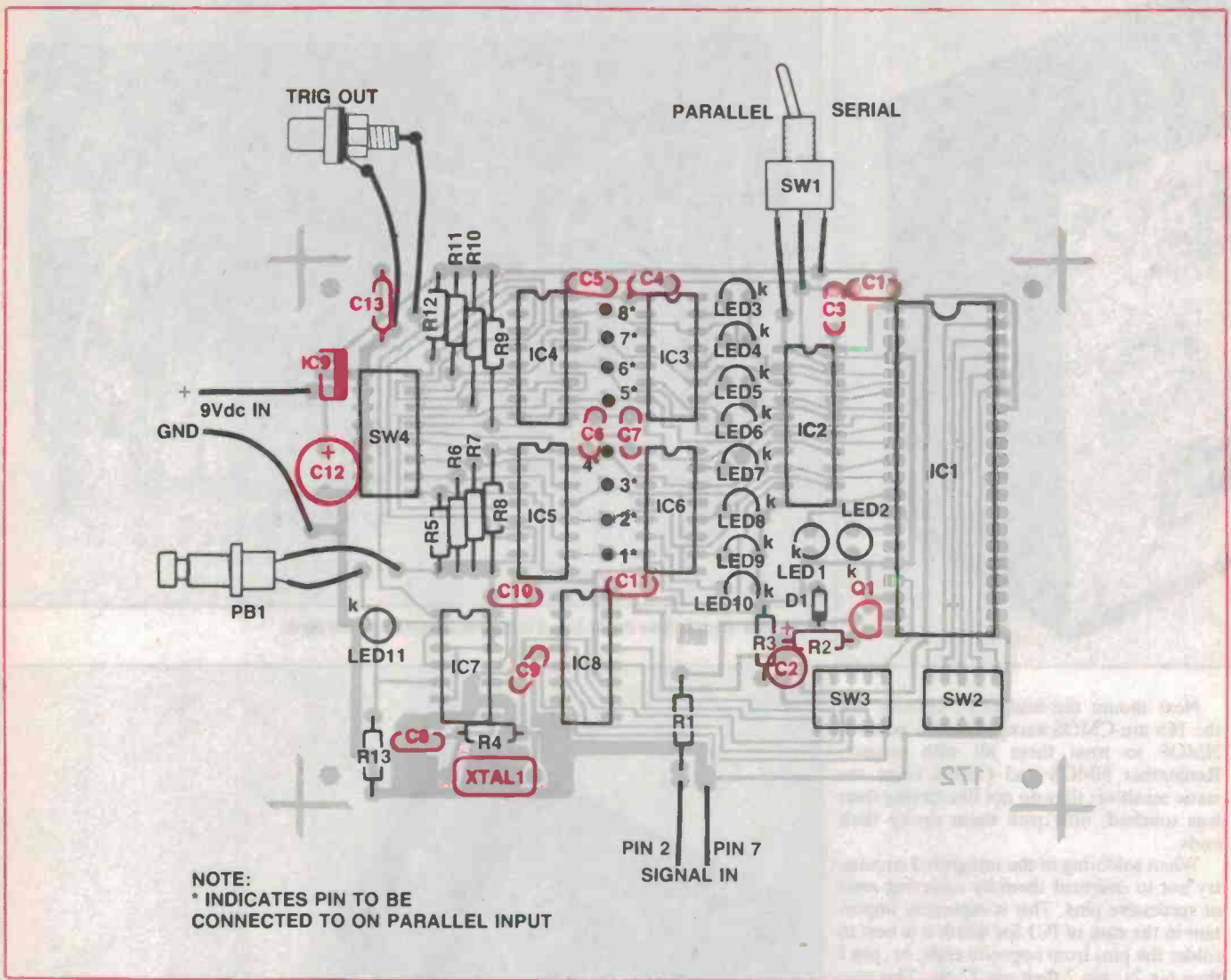

HOW IT WORKS — ETI-172

Some serial signals are 'non return to zero' (NRZ) meaning that a high state is represented by a positive voltage and a low state is represented by a negative voltage. The diode D1 is used to convert any NRZ signals to 'return to zero' signals and the transistor Q1 is used to set the signal level at 5 volts. The resultant signal output from Q1 will comply to TTL standards, that is, 5 volts as a high level and 0 volts as a low level. This signal conditioning is performed because the UART (IC1) requires TTL input signals.

The oscillator circuit consisting of the crystal, the NOR gate (IC7c), R4, C8 and C9 oscillates at a frequency of 2.457 MHz. This signal is divided down by the 7-bit ripple counter, IC8, to provide five different baud rates. These rates are switched to the UART by the bank of DIP switches, SW3.

The UART removes start and stop bits from the incoming serial bit stream and converts the serial data into parallel data.

SW2 is used to set up the UART for the correct parity, and correct number of data and stop bits. LEDs 1 and 2 indicate errors with parity and stop bits respectively.

After the serial data has been converted into parallel data, it is compared with the settings on the DIP switches (SW4) via ICs 4 and 5. When the bit pattern is the same as the switch settings, pin 6 of IC4 goes low. However, this output goes high again when a bit pattern different from the switch setting occurs. To latch this output an R-S flip-flop is used. This consists of NOR gates IC7a and IC7b. IC7d is used to invert the latched signal to a high level and thus switch on LED11 to indicate that the bit pattern has been detected.

IC2 is an octal tristate buffer which is used to select between serial and parallel incoming data by SW1. When SW1 is in the serial position, the data output from the UART is connected to the comparators. When this switch is in the parallel position

the data output from the UART is disabled from the rest of the circuit, isolating the outputs of IC1 from incoming data. Otherwise this data would be fed into the outputs of the UART.

LEDs 3 to 10 display the incoming data in a binary form. They are driven by the non-inverting buffers IC3 and IC5. Thus the loading on IC2 is reduced when the circuit is examining serial data. The loading of the source of the parallel data is reduced when the circuit is examining parallel data.

The 10 nF capacitors connected between the Vcc pin of the integrated circuits and ground remove transients and any other undesirable ac signals which may be picked up by the Vcc rail. On the pc board, these components are located next to the Vcc pins of each integrated circuit. Capacitors C12 and C13 perform the above mentioned task for the incoming dc supply.

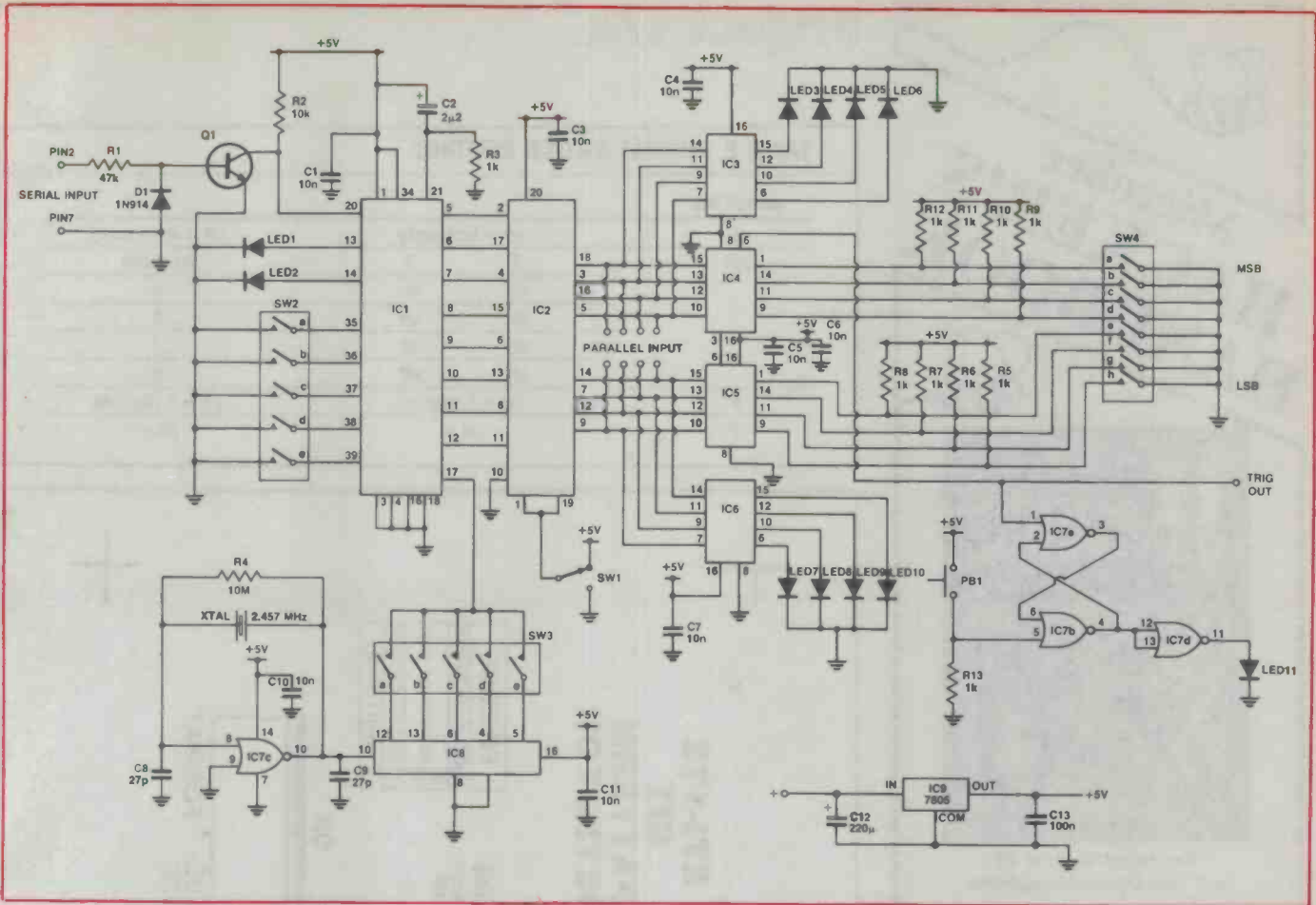

PARTS LIST — ETI-172

- Resistors.....all 1/4 W, 5%
- R1.....47k
- R2.....10k
- R3, R5-R13.....1k
- R4.....10M
- Capacitors
- C1, C3-C7, C10, C11.....10n
- C2.....2μ2 25 V electro
- C8, C9.....27p
- C12.....220μ 25 V electro
- C13.....100n greencap
- Semiconductors
- D1.....1N914
- LED 1,2,11.....red 5 mm
- LED 3-10.....green 5 mm
- Q1.....BC549
- IC1.....AY-1015D UART
- IC2.....74HC244
- IC3,6.....4050
- IC4,5.....74HC85
- IC7.....4001
- IC8.....4020
- IC9.....7805
- Miscellaneous
- SW1.....SPDT
- SW2,3.....5-way DIP switch
- SW4.....8-way DIP switch
- PB1.....pushbutton switch
- DB 25 plug; 2.457 MHz crystal; case 160 mm x 95 mm x 50 mm; RCA socket; 3.5 mm phono socket; ETI-172 pc board.
- Price estimate: \$55 serial/parallel version**
- \$30 parallel version**

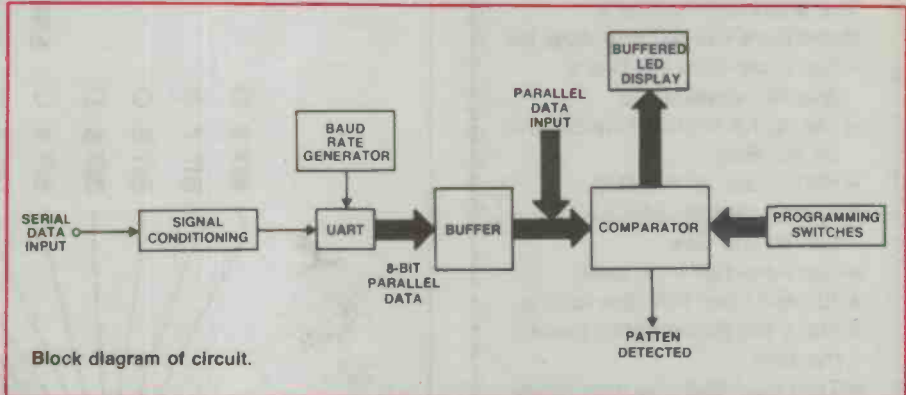

aligning this diagram over your front panel, it can be used as a drilling template. When you have it in position, lightly punch the centres of all holes. To make the centres more accurate it may help to have a hard surface under the front panel when you are punching it. The outlines for the DIP switches can be marked by cutting through the diagram with a sharp blade or scalpel. This will transfer all the required markings on to the metal.

When you are drilling the 5 mm diameter holes it is advisable to drill a pilot hole first, using a 3 mm drill. Now use the 5 mm drill where required. The edges of these holes can be cleaned using a large drill bit. The rectangular holes for the DIP switches can be cut using a nibbling tool or by drilling a

series of holes and filing between them.

The circuit board can now be mounted behind the front panel using four 6 BA nuts and bolts. Some 5 mm spacers should provide adequate clearance between the front panel and the pc board. With a bit of wiggling the LEDs and the DIP switches should protrude through the front panel. If you have difficulty in getting the DIP switches through, file the holes gradually until they do. If the LEDs give you difficulty, twist them until they are evenly spaced so that they can be located in the holes.

Before you connect in the plugpack carefully examine the pc board for solder bridges; also check that all the components are located and oriented correctly on the board. Now connect the 9 volt plugpack, ▶

Microbee HACKER'S HANDBOOK

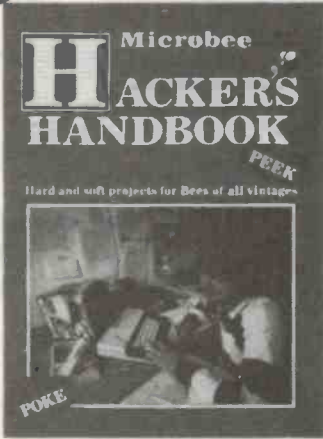

From the publishers of 'ETI' and 'Your Computer' magazines.

The Microbee Hacker's Handbook will tell you how to:

- Get more from the Bee's graphics capabilities.
- Set up for telecommunications on the Bee.
- Play music on the Bee.
- Build a joystick and a light pen for the Bee.
- Get hardcopy — cheaply.
- Expand your 16K Bee to 32K.
- Make the Bee a better games machine.
- Turn your Bee into a facsimile decoder.
- Solve equations on the Bee ... and much more!

\$6.50 at your newsagent now.

OR you can obtain your copy by mail order direct from:
Federal Marketing Book Sales
 P.O. Box 227,
 Waterloo, N.S.W. 2017
 Please add \$1 to the cost of the magazine to cover postage and handling.

TABLE 2. FORMAT SWITCH SETTINGS

Switch No.	on = odd parity		off = even parity
1			
2,3	2	3	no of bits
	on	on	5
	off	on	6
	on	off	7
	off	off	8
4	on = 1 stop bit		off = 2 stop bits
5	on =		off =

ETI-172 BIT PATTERN DETECTOR

BIT 8 ○
 BIT 7 ○
 BIT 6 ○
 BIT 5 ○
 BIT 4 ○
 BIT 3 ○
 BIT 2 ○
 BIT 1 ○

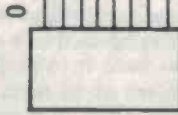

SERIAL ○

PARALLEL

FORMAT
1 ODD/EVEN PARITY
2 NUMBER OF BITS
3 No OF STOP BITS
4 PARIITY ON/OFF

ERRORS STOP BIT ○
 PARIITY BIT ○

ON

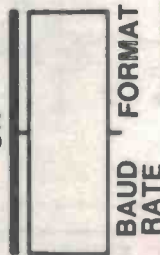

BAUD RATE
1 300
2 600
3 1200
4 2400
5 4800

○ PATTERN DETECTED

○ RESET



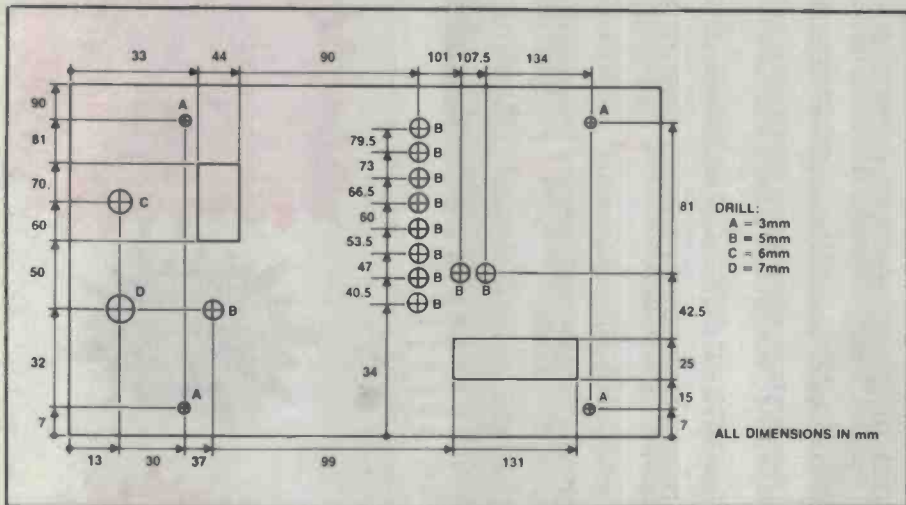
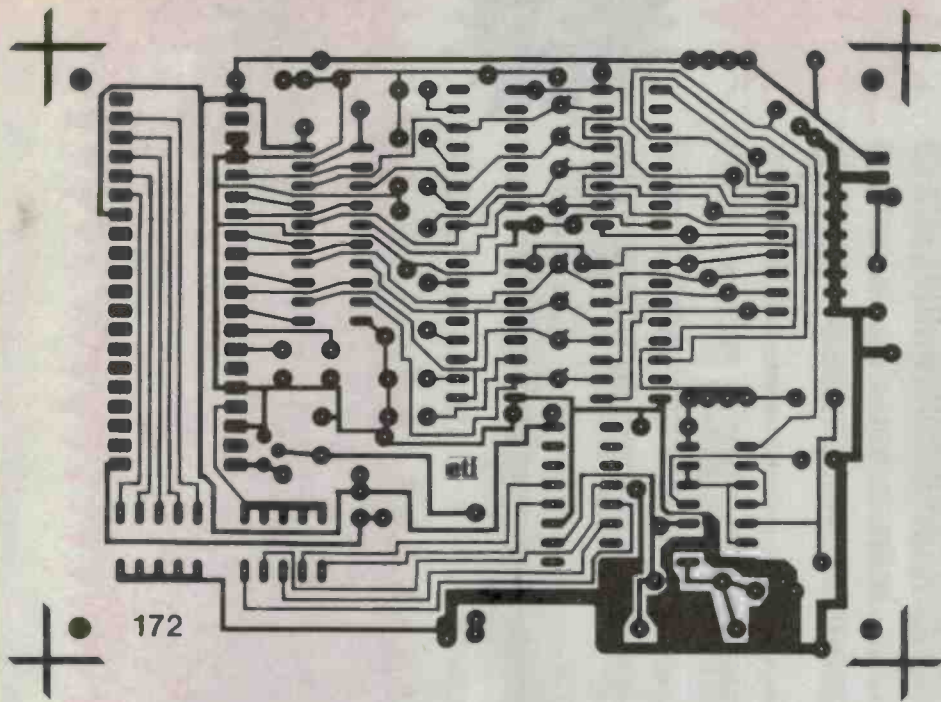

and check that the voltage rails are within 500 mV of 5 volts. If not, disconnect the plugpack and check for short circuits on the pc board in the vicinity of the 5 volt supply rails.

To test the bit pattern detector set the 8-bit programming DIP switches to '0' and the pattern detected LED should light up. Switch any of the DIP switches to the '1' position and press the RESET button. The PATTERN DETECTED LED should go out. If this does not occur, recheck the board for shorts, broken tracks or dry joints.

Using it

When detecting bytes on a serial line firstly set up the BAUD RATE and FORMAT DIP switches to suit the serial port. Table 2 shows the settings for these switches. Next set the binary value of the

byte to be detected on the eight DIP switches next to the SERIAL/PARALLEL switch. The top switch (bit 8) is the most significant bit and the bottom one (bit 1) is the least significant bit. Now send the data stream or the specific byte to be detected from this port. If either of the ERROR LEDs light up, check that the FORMAT or BAUD RATE DIP switches are set correctly.

To detect bit patterns or bytes on a parallel data bus, firstly flip the SERIAL/PARALLEL switch to the PARALLEL position and connect the relevant pins on the DB 25 connector (listed in Table 1) to the relevant lines on the parallel data bus. The eight LEDs should indicate the state of these lines. If a particular pattern is to be detected set its binary value on the DIP switches and the PATTERN DETECTED LED should light up when it appears on the data bus.●



**65XXX — 68000
SAVE \$\$\$\$**

6500 SERIES		DISPLAY CONTROLLERS	
R6502P	8.50	10937P-50	11.02
R6502AP	9.28	10951P-50	11.02
R6503AP	7.24	10938P	9.44
R6504AP	7.24	10939P	9.44
R6505AP	7.24	10941P	9.44
R6507AP	7.24	10942P	9.44
R6511Q	21.26	10943P	9.44
R6511AQ	23.28		
R6520P	5.19	16 BIT 68000 SERIES I.C.'s	
R6520AP	5.98	R68000C10	69.24
R6522P	6.77	R68000Q10	33.04
R6522AP	7.55	R68465P	16.52
R6532P	9.44	R68C552P	27.07
R6532AP	10.39	R68561P	58.22
R6541Q	19.17	R68802P	61.37
R6541AQ	21.09	MEMORY I.C.'s	
R6545-1P	9.13	2114	1.35
R6545-1AP	10.70	4116	2.65
R6545AP	12.27	4164	1.35
R6549P	60.58	41256	6.67
R6551P	9.91	6116	7.18
R6551AP	10.70	6264	20.26
		2716	4.81

CMOS DEVICES	
R65C02P1	10.39
R65C02P2	11.80
R65C102P1	10.39
R65C102P2	11.80
R65C21P1	5.82
R65C21P2	6.77
R65C22P1	7.71
R65C24P1	6.61
R65C24P2	7.71
R65C51P1	12.27
R65C51P2	13.53
R65C52P1	22.03
R65C52P2	24.86

CRYSTALS	
32.768 KHz - CMOS	
Calendar	1.96
1.8432MHz	3.08
2,000MHz	3.08
2.4576MHz	1.96
3.6864MHz	1.96
4.000MHz	1.96
4.9152MHz	2.80
8.000MHz	1.96
12.000MHz	1.96

HIGH LEVEL LANGUAGE CIRCUITS	
R65F11P	32.42
R65F11AP	35.72
R65F12Q	42.33
R65F12AQ	46.58
R65FR1P	97.25
R65RT2P	97.25
R65FR3P	97.25
R65FK2P	10.70

MODEMS	
R1212M	358.05
R1212DS	267.51
R2424M	590.22
R2424DS	361.93

Please include \$6.50 for packaging and freight

All prices include sales tax

Prices subject to alteration without notification



73 Eric Street, Goodna Q 4300
P.O. Box 6502, Goodna Q 4300
Telephone (07) 288 2455
Telex AA43778 ENECON

SUPER IC SPECIAL 27128
1-9 10-99 100+
\$7.00 \$6.50 \$6.25

SUPER IC SPECIAL 41256
1-9 10-99 100+
\$7.00 \$6.50 \$6.00

SUPER IC SPECIAL 6116LP-3
1-9 10-99 100+
\$3.95 \$3.75 \$3.50

SUPER IC SPECIAL 6264
1-9 10-99 100+
\$6.50 \$5.50 \$5.25

1/2 PRICE!
During April, we are offering the following semi's at 1/2 price!
...but be quick!

ICL7106 19.50	74C374 4.45	74LS324 2.20	LM377 4.90	BD238 90	2N3055 1.00	6AMP 8271 99.00	HLMF 6620.35	4056 4.20
ICL7111 19.50	74C901 3.00	74LS328 2.20	LM378 3.95	BD262 1.20	2N3090 1.20	BPC602 2.90	LEDS	4060 2.50
ICL7117 21.50	74C902 2.50	74LS327 2.20	LM380 8 pins	BD283 1.20	2N3109 1.80	BPC604 3.50	3mm RED .25	4063 2.00
ICL7611 6.50	74C903 2.50	74LS337 2.20	LM380 8 pins	BD287 1.20	2N3151 1.80	BPC606 4.50	2mm YELL .30	4064 2.50
ICL7660 5.80	74C904 2.50	74LS353 2.20	LM380 14 pin	BD488 1.80	2N3202 1.80	10AMP	3mm GRN .30	4067 9.90
ICM7211 12.50	74C905 1.50	74LS354 3.95	LM381 1.90	BD487 1.80	2N3340 1.80	KBPC1002 4.20	5mm RED .15	4068 1.00
ICM7216A 48.50	74C906 2.90	74LS361 1.90	LM381 1.90	BD488 1.80	2N3341 2.90	KBPC1004 4.90	5mm YELL .30	4069 1.50
ICM7216B 48.50	74C907 2.75	74LS366 1.90	LM382 3.50	BD487 1.80	2N3342 3.50	35AMP	5mm GRN .30	4070 90
ICM7224A 21.50	74C908 2.75	74LS367 .60	LM383 3.90	BD481 2.00	2N3353 3.00	KBPC3502 8.90	5mm ONG .30	4071 .90
ICM7227A 19.95	74C909 2.50	74LS372 1.50	LM384 3.50	BD482 2.00	2N3354 3.00	KBPC3510 MDA	RED RECT .30	4072 .50
	74C910 2.50	74LS373 1.90	LM387A 3.95	BDV64B 3.90	2N3355 3.00	A3054 .50	RED RECT .30	4073 .90
	74C911 4.50	74LS375 1.00	LM388 2.00	BDV65B 3.90	2N3356 3.00	KBPC3510 MDA	YEL RECT .30	4075 .90
	74C912 12.50	74LS377 2.15	LM390 2.55	BDV65C 6.50	2N3357 3.00	3510 9.90	RED CHROME	4076 1.80
	74C913 1.50	74LS378 1.20	LM391 2.55	Y96 (BUX)RO	2N3358 3.00	FD1771 19.00	BEZEL 1.20	4077 .90
	74C914 2.90	74LS379 1.90	LM393 1.00	BDY97 (BUX)RO	2N3359 3.00	7405 80	YELLOW	4078 .80
	74C915 1.50	74LS380 1.90	LM393 1.00	BDY97 (BUX)RO	2N3360 3.00	7406 35	CHME BEZEL	4081 .40
	74C916 1.50	74LS381 1.90	LM393 1.00	BDY97 (BUX)RO	2N3361 3.00	7407 60	GRN CHROME	4085 2.20
	74C917 1.50	74LS382 1.90	LM393 1.00	BDY97 (BUX)RO	2N3362 3.00	7408 60	BEZEL 1.20	4086 3.30
	74C918 1.50	74LS383 1.90	LM393 1.00	BDY97 (BUX)RO	2N3363 3.00	7409 60	VOLTAGE	4094 3.35
	74C919 1.50	74LS384 1.90	LM393 1.00	BDY97 (BUX)RO	2N3364 3.00	7410 60	REDS	4095 2.40
	74C920 1.50	74LS385 1.90	LM393 1.00	BDY97 (BUX)RO	2N3365 3.00	7411 60	7805C 80	4096 2.40
	74C921 1.50	74LS386 1.90	LM393 1.00	BDY97 (BUX)RO	2N3366 3.00	7412 60	7805C 80	4097 6.50
	74C922 1.50	74LS387 1.90	LM393 1.00	BDY97 (BUX)RO	2N3367 3.00	7413 60	7812UC 1.20	4098 2.00
	74C923 1.50	74LS388 1.90	LM393 1.00	BDY97 (BUX)RO	2N3368 3.00	7414 60	7812UC 1.20	4099 3.00
	74C924 1.50	74LS389 1.90	LM393 1.00	BDY97 (BUX)RO	2N3369 3.00	7415 60	7812UC 1.20	4100 1.50
	74C925 1.50	74LS390 1.90	LM393 1.00	BDY97 (BUX)RO	2N3370 3.00	7416 60	7812UC 1.20	4101 1.50
	74C926 1.50	74LS391 1.90	LM393 1.00	BDY97 (BUX)RO	2N3371 3.00	7417 60	7812UC 1.20	4102 1.50
	74C927 1.50	74LS392 1.90	LM393 1.00	BDY97 (BUX)RO	2N3372 3.00	7418 60	7812UC 1.20	4103 1.50
	74C928 1.50	74LS393 1.90	LM393 1.00	BDY97 (BUX)RO	2N3373 3.00	7419 60	7812UC 1.20	4104 1.50
	74C929 1.50	74LS394 1.90	LM393 1.00	BDY97 (BUX)RO	2N3374 3.00	7420 60	7812UC 1.20	4105 1.50
	74C930 1.50	74LS395 1.90	LM393 1.00	BDY97 (BUX)RO	2N3375 3.00	7421 60	7812UC 1.20	4106 1.50
	74C931 1.50	74LS396 1.90	LM393 1.00	BDY97 (BUX)RO	2N3376 3.00	7422 60	7812UC 1.20	4107 1.50
	74C932 1.50	74LS397 1.90	LM393 1.00	BDY97 (BUX)RO	2N3377 3.00	7423 60	7812UC 1.20	4108 1.50
	74C933 1.50	74LS398 1.90	LM393 1.00	BDY97 (BUX)RO	2N3378 3.00	7424 60	7812UC 1.20	4109 1.50
	74C934 1.50	74LS399 1.90	LM393 1.00	BDY97 (BUX)RO	2N3379 3.00	7425 60	7812UC 1.20	4110 1.50
	74C935 1.50	74LS400 1.90	LM393 1.00	BDY97 (BUX)RO	2N3380 3.00	7426 60	7812UC 1.20	4111 1.50
	74C936 1.50	74LS401 1.90	LM393 1.00	BDY97 (BUX)RO	2N3381 3.00	7427 60	7812UC 1.20	4112 1.50
	74C937 1.50	74LS402 1.90	LM393 1.00	BDY97 (BUX)RO	2N3382 3.00	7428 60	7812UC 1.20	4113 1.50
	74C938 1.50	74LS403 1.90	LM393 1.00	BDY97 (BUX)RO	2N3383 3.00	7429 60	7812UC 1.20	4114 1.50
	74C939 1.50	74LS404 1.90	LM393 1.00	BDY97 (BUX)RO	2N3384 3.00	7430 60	7812UC 1.20	4115 1.50
	74C940 1.50	74LS405 1.90	LM393 1.00	BDY97 (BUX)RO	2N3385 3.00	7431 60	7812UC 1.20	4116 1.50
	74C941 1.50	74LS406 1.90	LM393 1.00	BDY97 (BUX)RO	2N3386 3.00	7432 60	7812UC 1.20	4117 1.50
	74C942 1.50	74LS407 1.90	LM393 1.00	BDY97 (BUX)RO	2N3387 3.00	7433 60	7812UC 1.20	4118 1.50
	74C943 1.50	74LS408 1.90	LM393 1.00	BDY97 (BUX)RO	2N3388 3.00	7434 60	7812UC 1.20	4119 1.50
	74C944 1.50	74LS409 1.90	LM393 1.00	BDY97 (BUX)RO	2N3389 3.00	7435 60	7812UC 1.20	4120 1.50
	74C945 1.50	74LS410 1.90	LM393 1.00	BDY97 (BUX)RO	2N3390 3.00	7436 60	7812UC 1.20	4121 1.50
	74C946 1.50	74LS411 1.90	LM393 1.00	BDY97 (BUX)RO	2N3391 3.00	7437 60	7812UC 1.20	4122 1.50
	74C947 1.50	74LS412 1.90	LM393 1.00	BDY97 (BUX)RO	2N3392 3.00	7438 60	7812UC 1.20	4123 1.50
	74C948 1.50	74LS413 1.90	LM393 1.00	BDY97 (BUX)RO	2N3393 3.00	7439 60	7812UC 1.20	4124 1.50
	74C949 1.50	74LS414 1.90	LM393 1.00	BDY97 (BUX)RO	2N3394 3.00	7440 60	7812UC 1.20	4125 1.50
	74C950 1.50	74LS415 1.90	LM393 1.00	BDY97 (BUX)RO	2N3395 3.00	7441 60	7812UC 1.20	4126 1.50
	74C951 1.50	74LS416 1.90	LM393 1.00	BDY97 (BUX)RO	2N3396 3.00	7442 60	7812UC 1.20	4127 1.50
	74C952 1.50	74LS417 1.90	LM393 1.00	BDY97 (BUX)RO	2N3397 3.00	7443 60	7812UC 1.20	4128 1.50
	74C953 1.50	74LS418 1.90	LM393 1.00	BDY97 (BUX)RO	2N3398 3.00	7444 60	7812UC 1.20	4129 1.50
	74C954 1.50	74LS419 1.90	LM393 1.00	BDY97 (BUX)RO	2N3399 3.00	7445 60	7812UC 1.20	4130 1.50
	74C955 1.50	74LS420 1.90	LM393 1.00	BDY97 (BUX)RO	2N3400 3.00	7446 60	7812UC 1.20	4131 1.50
	74C956 1.50	74LS421 1.90	LM393 1.00	BDY97 (BUX)RO	2N3401 3.00	7447 60	7812UC 1.20	4132 1.50
	74C957 1.50	74LS422 1.90	LM393 1.00	BDY97 (BUX)RO	2N3402 3.00	7448 60	7812UC 1.20	4133 1.50
	74C958 1.50	74LS423 1.90	LM393 1.00	BDY97 (BUX)RO	2N3403 3.00	7449 60	7812UC 1.20	4134 1.50
	74C959 1.50	74LS424 1.90	LM393 1.00	BDY97 (BUX)RO	2N3404 3.00	7450 60	7812UC 1.20	4135 1.50
	74C960 1.50	74LS425 1.90	LM393 1.00	BDY97 (BUX)RO	2N3405 3.00	7451 60	7812UC 1.20	4136 1.50
	74C961 1.50	74LS426 1.90	LM393 1.00	BDY97 (BUX)RO	2N3406 3.00	7452 60	7812UC 1.20	4137 1.50
	74C962 1.50	74LS427 1.90	LM393 1.00	BDY97 (BUX)RO	2N3407 3.00	7453 60	7812UC 1.20	4138 1.50
	74C963 1.50	74LS428 1.90	LM393 1.00	BDY97 (BUX)RO	2N3408 3.00	7454 60	7812UC 1.20	4139 1.50
	74C964 1.50	74LS429 1.90	LM393 1.00	BDY97 (BUX)RO	2N3409 3.00	7455 60	7812UC 1.20	4140 1.50
	74C965 1.50	74LS430 1.90	LM393 1.00	BDY97 (BUX)RO	2N3410 3.00	7456 60	7812UC 1.20	4141 1.50
	74C966 1.50	74LS431 1.90	LM393 1.00	BDY97 (BUX)RO	2N3411 3.00	7457 60	7812UC 1.20	4142 1.50
	74C967 1.50	74LS432 1.90	LM393 1.00	BDY97 (BUX)RO	2N3412 3.00	7458 60	7812UC 1.20	4143 1.50
	74C968 1.50	74LS433 1.90	LM393 1.00	BDY97 (BUX)RO	2N3413 3.00	7459 60	7812UC 1.20	4144 1.50
	74C969 1.50	74LS434 1.90	LM393 1.00	BDY97 (BUX)RO	2N3414 3.00	7460 60	7812UC 1.20	4145 1.50
	74C970 1.50	74LS435 1.90	LM393 1.00	BDY97 (BUX)RO	2N3415 3.00	7461 60	7812UC 1.20	4146 1.50
	74C971 1.50	74LS436 1.90	LM393 1.00	BDY97 (BUX)RO	2N3416 3.00	7462 60	7812UC 1.20	4147 1.50
	74C972 1.50	74LS437 1.90	LM393 1.00	BDY97 (BUX)RO	2N3417 3.00	7463 60	7812UC 1.20	4148 1.50
	74C973 1.50	74LS438 1.90	LM393 1.00	BDY97 (BUX)RO	2N3418 3.00	7464 60	7812UC 1.20	4149 1.50
	74C974 1.50	74LS439 1.90	LM393 1.00	BDY97 (BUX)RO	2N3419 3.00	7465 60	7812UC 1.20	4150 1.50
	74C975 1.50	74LS440 1.90	LM393 1.00	BDY97 (BUX)RO	2N3420 3.00	7466 60	7812UC 1.20	4151 1.50
	74C976 1.50	74LS441 1.90	LM393 1.00	BDY97 (BUX)RO	2N3421 3.00	7467 60	7812UC 1.20	4152 1.50
	74C977 1.50	74LS442 1.90	LM393 1.00	BDY97 (BUX)RO	2N3422 3.00	7468 60	7812UC 1.20	4153 1.50
	74C978 1.50	74LS443 1.90	LM393 1.00	BDY97 (BUX)RO	2N3423 3.00	7469 60	7812UC 1.20	4154 1.50
	74C979 1.50	74LS444 1.90	LM393 1.00	BDY97 (BUX)RO	2N3424 3.00	7470 60	7812UC 1.20	4155 1.50
	74C980 1.50	74LS445 1.90	LM393 1.00	BDY97 (BUX)RO	2N3425 3.00	7471 60	7812UC 1.20	4156 1.50
	74C981 1.50	74LS446 1.90	LM393 1.00	BDY97 (BUX)RO	2N3426 3.00	7472 60	7812UC 1.20	4157 1.50
	74C982 1.50	74LS447 1.90	LM393 1.00	BDY97 (BUX)RO	2N3427 3.00	7473 60	7812UC 1.20	4158 1.50
	74C983 1.50	74LS448 1.90	LM393 1.00	BDY97 (BUX)RO	2N3428 3.00	7474 60	7812UC 1.20	4159 1.50
	74C984 1.50	74LS449 1.90	LM393 1.00	BDY97 (BUX)RO	2N3429 3.00	7475 60	7812UC 1.20	4160 1.50
	74C985 1.50	74LS450 1.90	LM393 1.00	BDY97 (BUX)RO	2N3430 3.00	7476 60	7812UC 1.20	4161 1.50
	74C986 1.50	74LS451 1.90	LM393 1.00	BDY97 (BUX)RO	2N3431 3.00	7477 60	7812UC 1.20	4

LATEST KITS!

PLAYMASTER FM/AM STEREO TUNER

The new Playmaster FM/AM stereo tuner will outperform anything presently available on the market, regardless of price. As well as including a FM tuner section which is every bit as good as any other synthesised design, it is also the only unit featuring a genuine wideband, low distortion AM stereo tuner. Naturally, it has a digital readout, 12 station memory automatic seek and an optional infrared remote control. (EA Dec. '85 Jan-Feb '86 BS12) Cat. K86020 \$399



THE BUSKER PORTABLE AMPLIFIER

This handy amplifier is completely portable and is capable of operating from either the mains or a 12V battery. Main features include guitar and high-level inputs, an inbuilt loudspeaker, and bass and treble controls. It's just the thing for busking or for guitar practice. (EA Feb. '85 BSa2) Cat. K85020 (excluding cabinet) \$99



SONICS ACTIVE DIRECT INSERTION BOX

This inexpensive, easy to build DI box was designed in conjunction with Sonics magazine and is fine for both live PA and home recording work. It takes an unbalanced input and produces an output suitable for driving a balanced audio line. (ETI 1401 Sept '85) Cat. K41401 \$39.95



"HANDS FREE" OR LOUDSPEAKER TELEPHONE ADATOR

This attractive desktop unit enables "Hands Free" two way conversation over the telephone. The advantages of being able to engage in a telephone conversation with both hands free to take notes, look up information, perform calculations or to operate a computer keyboard are both obvious and desirable. Now you can enjoy all the benefits for less than \$80! (EA Nov. '85) Cat. K86030 \$79



PREAMP FOR PAGING AMP

A versatile preamp with separate bass, treble and volume. (ETI 11421) Cat. K54210 \$24.95



COMPUTER DRIVEN RADIO-TELETYPE TRANSCIEVER

Here's what you've been asking for, a full transmit-receive system for computer driven radio teletype station. The software provides all the latest "whizz bangs" like split-screen operation, automatically repeating test message, printer output and more. The hardware uses tried and proven techniques. While designed to team with the popular Microbee, tips are available on interfacing the unit to other computers. (ETI Nov. '84) ETI 755) Cat. K47550 \$139



ELECTRIC FENCE CONTROLLER

Restore discipline to the farm or allotment with this new electric fence controller. It features higher output power and lower current drain than the previous design for use in rural areas. (EA Dec. '85, 85el11) Cat. K85110 \$44.95



VIDEO FADER CIRCUIT

Add a touch of professionalism to your video movies with this simple Video Fader Circuit. It enables you to fade a scene to black (and back again) without loss of picture lock (sync) or colour. (EA Jan. '86, 85H10) Cat. K86010 \$19.95



TOUCH LAMP TIMER

Just a quick dab with the fingers and this touch switch will turn on lights or most mains powered appliances for up to 10 minutes. (EA August '83, 83pc3b) Cat. K83084 \$21



RADIOTELETYPE CONVERTER FOR THE MICROBEE

Have your computer print the latest news from the international shortwave news service. Just hook up this project between your short wave receivers audio output and the MicroBee parallel port. A simple bit of software does the decoding. Can be hooked up to other computers too. (ETI Apr. '83) Cat. K47330 \$19.95



ELECTRONIC MOUSETRAP

This clever electronic mousetrap disposes of mice instantly and mercifully, without fail, and resets itself automatically. They'll never get away with the cheese again! (ETI Aug. '84) ETI 1524 Cat. K85240 \$34.95



MICROBEE SERIAL-TO-PARALLEL INTERFACE

Most microcomputers worth owning have an RS232 connector, or port, through which serial communications (input/output) is conducted. It is a convention that, for listing on a printer, the BASIC LIST or LPRINT command assumes a printer is connected to the RS232 port. Problems, serial interface printers are more expensive than parallel Centronics interface printers. Save money by building this interface. (ETI Jan. '84) ETI 675 Cat. K46750 \$59.50



ELECTRIC DUMMY LOAD

With this unit you can test power supplies at currents up to 15 Amps and voltage up to 60 Volts. It can "sink" up to 200 Watts on a static test and you can modulate the load to perform dynamic tests. (ETI Oct. '80) ETI 147 Cat. K41470 \$129



MUSICOLOR IV

Add excitement to parties, card nights and discos with EAs Musicolor IV light show. This is the latest in the famous line of musicolors and it offers features such as four channel "color organ" plus four channel light chaser, front panel LED display, internal microphone, single sensitivity control plus opto-coupled switching for increased safety. (EA Aug. '81) 81M08 Cat. K81080 \$99



PH METER KIT

Build this pH meter for the swimming pool season is here again! From swimming pools to fish tanks to gardening, this pH meter has many applications around the home. This unit features a large 1/2 digit liquid crystal display and resolution to 0.1 pH units, making it suitable for use in the laboratory as well. (EA Dec. '82) 82PH12 Cat. K82123 \$135



LOW OHMS METER

How many times have you cursed your Multimeter when you had to measure a low-value resistance? Well with the "Low Ohms Meter" you can solve those old problems and in fact measure resistance from 100 Ohms down to 0.005 Ohms. (ETI Nov. '81) ETI 158 Cat. K41580 \$39.50

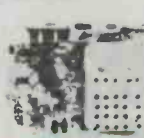

EPROM PROGRAMMER

No need for a Micro with EA's great EPROM Programmer suitable for 2716-2758 EPROMs. (EA Jan. '82) 82EP1 Cat. K82013 \$79.95 (Including Textool Socket)



PARABOLIC MICROPHONE

Build a low cost parabola, along with a high gain headphone amplifier to help when listening to those natural activities such as babbling brooks, singing birds or perhaps even more sinister noises. The current cost of components for this project is around \$15 including sales tax, but not the cost of batteries or headphones. (EA Nov. '83) 83MA11 Cat. K83110 \$14.95

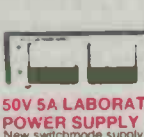

50V 5A LABORATORY POWER SUPPLY

New switchmode supply can deliver anywhere from three to 50V DC and currents of 5A at 50V or lower. Highly efficient design. (EA May. '83) 83PS5 Cat. K83050 \$169



TEMP PROBE

Can measure temperature from -50 to 150°C. It simply plugs into your multimeter - great for digital multimeters. Accuracy of 0.1°C resolution of 0.1°C (ETI June '83) ETI 153 Cat. K41530 \$26.95



LOW BATTERY VOLTAGE INDICATOR

Knowing your batteries are about to give up on you could save many an embarrassing situation. This simple low cost project will give you early warning of power failure, and makes a handy beginner's project. (ETI 280, March '85) Cat. K42800 \$7.95



DUAL TRACKING POWER SUPPLY

Build a dual positive and negative 3-Terminal Regulators, this versatile dual tracking Power Supply can provide voltages up to 2A. In addition the Supply features a fixed +5V 0.9A output and is completely protected against short circuits, overloads and thermal runaway. (EA March '82) 82PS2 Cat. K82030 \$109.00



MODEL ENGINE IGNITION SYSTEM

Get sure starts every time and no more glow plug burnouts on your model engines. (ETI June '83) ETI 1516 Cat. 55160 \$49.50



FUNCTION GENERATOR

This Function Generator with digital readout produces Sine, Triangle and Square waves over a frequency range from below 20Hz to above 150kHz with low distortion and good envelope stability. It has an inbuilt four-digit frequency counter for ease and accuracy of frequency setting. (EA April '82, 82A03A/B) Cat. K82040 \$109



CAR IGNITION KILLER

Most car burglar alarms are easily circumvented, but not this cunning "Ignition Killer". This sneaky anti-theft device uses a 555 timer to place an intermittent short circuit across the points. Until disabled by its hidden switch the circuit effectively makes the car undrivable - a sure deterrent to thieves! (EA Feb. '84) 84AU1 Cat. K84010 \$19.95 (Our kit includes the box!)

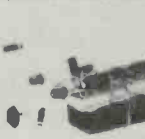

CUDLIPP CRICKET

A fascinating Electronic Cricket with just two ICs. The Cudlipp can be used to bug your home, office etc! Great fun! (EA Feb. '82) 82EG2 Cat. K82022 \$12.95



MICROBEE ENHANCER 1

This amazing kit for the Microbee is a must for all Microbee owners! Most expansion units up to this time offered at best only one or other features; and this made it impossible to run, for example, complex sound effects mingled with speech. The Enhancer 1 will do all this and much more as well. It is quite amazing how much has been shoe-horned into this compact unit. The Enhancer 1's many powerful features include:

- Two ATARI/COMMODORE/COLECO/SEARS type joystick inputs
- Two TRS COLOUR COMPUTER type joystick inputs
- Allows the connection of Touch Pads, Paddles, Proportional Joysticks, Trackballs, Mice, temperature sensors, lights level sensors, transducers, etc, etc!
- A 4 voice music/sound effects synthesizer
- A real time clock
- Unlimited vocabulary speech synthesizer (option)
- Parallel printer interface (option)
- A built-in speaker with volume control
- Listings of all necessary routines for use
- An impressive demonstration program package
- Compatible to all Microbees
- Digital recording and playback of speech and sound
- An 8 channel analog to digital converter with variable voltage or variable resistance type analog inputs and also user selectable resolution from 1 to 9 bits
- A digital to analog converter with selectable resolution from 1-8 bits
- Allows automatic data acquisition and logging
- 5 digital input lines, 4 digital output lines
- A voice input channel
- A 40 pin experimenter socket with all 8 analog inputs, 5 digital inputs, 4 digital outputs, 3.58 MHz buffered clock, sound output (so that you can play the sound effects through your Hi Fi), a high resolution voltage comparators, DAC output etc.

The amazing Microbee Enhancer is available exclusively from Rod Irving Electronics. \$149

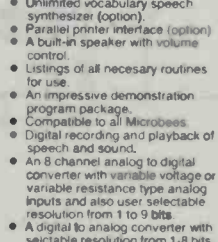

VIDEO AMPLIFIER

Bothered by smeary colours, signal beats and RFI interference on your computer display? Throw away that cheap and nasty RFI modulator and use a direct video connection. Instead, it's much better! The Video Amplifier features adjustable gain and provides both normal and inverted outputs. Power is derived from a 12V DC plug-pack supply. (EA Aug. '83) 83VA Cat. K83081 \$18.95

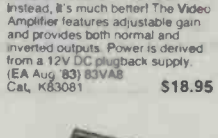
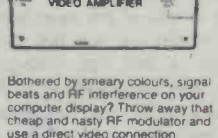
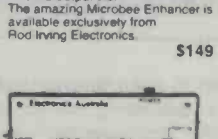

This project can be built to give a readout of relative humidity either on a LED dot-matrix display or a conventional meter. In addition it can be used with another project as a controller to turn on and off a water mist spray in a hothouse, for example. (ETI May '81) ETI-256 (Includes humidity sensor \$19.50) Cat. K52460 \$29.50



12-240V DC-AC INVERTER

This EA inverter is capable of driving mains appliances rated up to 300VA and features voltage regulation and full over load protection. (EA June '82) 82IV6
Nominal Supply: Voltage 12V DC
Output: Voltage see table
Frequency: 50Hz ± 0.05%
Regulation: see table
Maximum Load: 300VA
Current Limiting: 30A (primary)
Efficiency: see table

Relative Load Watts	Output Voltage (RMS)	Input Current (A)	Efficiency (%)	Battery life 40Ah-200Ah Rate (minutes)
0	210	1.2	0	
40	235	4.5	60	240
100	240	11.3	62	80
140	240	15.0	69	60
200	240	20.7	78	50
240	240	24.0	79	32
300	235	29.6	82	28

P&P \$10.00 Anywhere in Australia
Cat. K82062 \$195



NAIL FINDER

Essential for electricians and handymen. The Nail Finder will help locate timber studs behind Gyprock or plasterboard wall surfaces, as well as locating pipes and wiring behind walls. (EA Oct. '83) Cat. K83100 \$11.95



ELECTRIC FENCE

Mains or battery powered, this electric fence controller is both inexpensive and versatile. Based on an automotive ignition coil, it should prove an adequate deterrent to all manner of livestock. Additionally, its operation conforms to the relevant clauses of Australian Std 3129. (EA Sept. '82) 82EF9 Cat. K82092 \$19.50



ROD IRVING ELECTRONICS

405 HIGH STREET, NORTHCOTE, 3070 VICTORIA, AUSTRALIA
Phone (03) 489 8866
48 A Beckett St, MELBOURNE, 3000 VICTORIA, AUSTRALIA
Ph. (03) 663 6151
Mail Order and correspondence:
P. O. Box 620, CLAYTON 3168
TELEX: AA 151938



MAIL ORDER HOTLINE (03) 543 7877 (2 lines)

POSTAGE RATES
\$11-99 \$2.00
\$10-\$24.99 \$3.00
\$25-\$49.99 \$4.00
\$50-\$99.99 \$5.00
\$100-199 \$7.50
\$200-\$499 \$10.00
\$500 plus \$12.50
This is for basic postage only. Comet Road freight, bulky and fragile items will be charged at different rates.
Certified Post for orders over \$100 included "free"
Registered Post for orders over \$200 included "free"
All sales tax exempt orders and wholesale inquiries to RITRONICS WHOLESALE, 56 Rafter Rd, Clayton Phone (03) 543 2166
Errors and Omissions Excepted.



IDEA OF THE MONTH

Metronome

Patricia Vandermost,
Cheltenham, Vic 3192

This metronome circuit produces a regular click from a speaker variable over the range

of approximately 30 to 200 clicks per minute and also includes an LED which can be set to indi-

cate the downbeat. This is varied via SW1 to flash every one to six clicks of the speaker for different time signatures.

The circuit uses a UJT as a relaxation oscillator to produce variable pulses to click the speaker and also to advance the Johnson counter, IC1. The rate is varied via RV1. The outputs of the counter IC1 will go high in turn from Q1 to Q6 with each pulse of the oscillator. When the output connected to SW1 goes high, the collector of Q3 will provide a negative going pulse to trigger the monostable timer, IC2. The output of IC2 will flash the LED for a time determined by R9 and C9 and also reset IC1 to begin counting again.

SW2 is a four position switch with four diodes connected to select off, LED only, speaker only, or both together.

RV1 is a logarithmic slide pot connected in reverse to make the scale more linear while SW1 and SW2 are both slide switches.

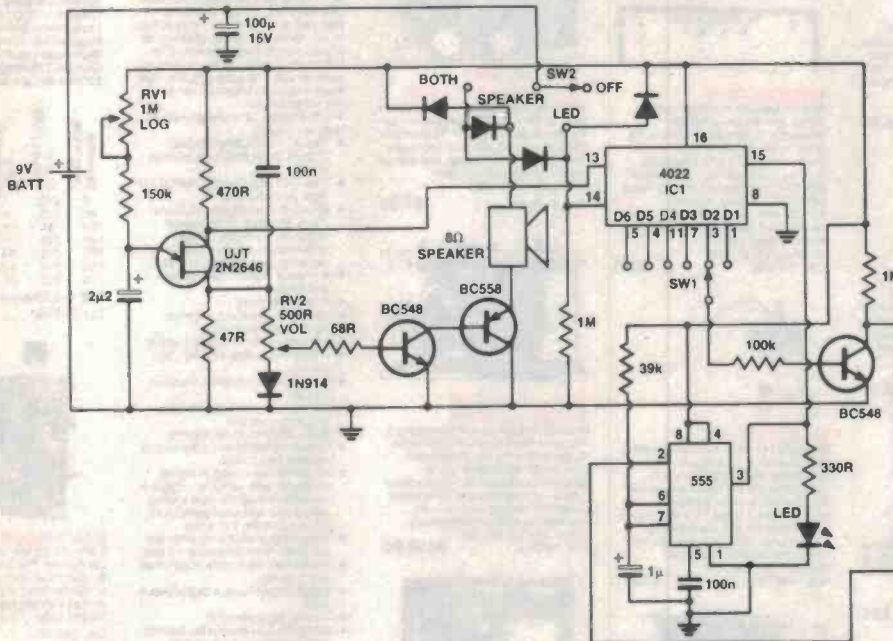

'IDEA OF THE MONTH' CONTEST

Scope Laboratories, which manufactures and distributes soldering irons and accessory tools, is sponsoring this contest with a prize given away every month for the best item submitted for publication in the 'Ideas for Experimenters' column — one of the most consistently popular features in ETI Magazine. Each month we will be giving away a 60 W Portable Cordless Soldering Iron, a 240 Volt Charging Adaptor together with a Holder Bracket. The prize is worth approx. \$100.

Selections will be made at the sole discretion of the editorial staff of ETI Magazine. Apart from the prize, each person will be paid \$20 for an item published. You must submit original ideas of circuits which have not previously been published. You may send as many entries as you wish.

COUPON

Cut and send to: Scope/ETI 'Idea of the Month' Contest, ETI Magazine, P.O. Box 227, Waterloo NSW 2017.

"I agree to the above terms and grant *Electronics Today International* all rights to publish my idea in ETI Magazine or other publications produced by it. I declare that the attached idea is my own original material, that it has not previously been published and that its publication does not violate any other copyright."

* Breach of copyright is now a criminal offence.

Title of Idea

Signature Date

Name

Address

Postcode



RULES

This contest is open to all persons normally resident in Australia, with the exception of members of the staff of Scope Laboratories, The Federal Publishing Company Pty Limited, ESN, The Litho Centre and/or associated companies.

Closing date for each issue is the last day of the month. Entries received within seven days of that date will be accepted if postmarked to and including the date of the last day of the month.

The winning entry will be judged by the editor of ETI Magazine, whose decision will be final. No correspondence can be entered into regarding the decision.

The winner will be advised by telegram the same day the result is declared. The name of the winner, together with the winning idea, will be published in the next possible issue of ETI Magazine.

Contestants must enter their names and addresses where indicated on each entry form. Photostats or clearly written copies will be accepted but if sending copies you must cut out and include with each entry the month and page number from the bottom of the page of the contest. In other words, you can send in multiple entries but you will need extra copies of the magazine so that you send an original page number with each entry.

This contest is invalid in states where local laws prohibit entries. Entrants must sign the declaration on the coupon that they have read the above rules and agree to abide by their conditions.

Microbee appliance timer

This circuit and accompanying software designed by Sean Machin of Lismore Heights, NSW, allows you to switch mains appliances on and off at specified times using a Microbee computer. The circuit needs care as you will be playing with a lethal 240 V.

The hardware is simple: whenever data line D0 is latched, it turns on the transistor which energises the relay. The relay should have 240 V rated contacts and a 12 V coil. D1 is included to stop back-emf from the relay and C1 is connected across the power rails to reduce power fluctuations when the relay is operating. LP1 is a small 12 V panel lamp which indicates when the output is turned on. The whole circuit is powered from the Microbee but to operate it requires 10 to 12 volts from pin 9 on the parallel port. If your 'Bee has no power on this pin then you will have to solder a jumper wire between pin 9 and the positive lead of C29 (the main filter capacitor in the 'Bee). The mains plug and inline socket may be obtained by cutting a short extension cord in half. It is important to use a correctly rated relay and to insulate the 240 V connections from the rest of the circuit.

The software acts as a real time clock and allows you to latch the relay on and off whenever you want. The clock displays the time in 24 hour mode so you will have to enter the time in 24 hour mode (including the "/" spacers between hours, minutes and seconds). Note that if RETURN is pressed in response to the first input, the output will be latched on immediately and latched off at the specified switch-off time. Similarly, if RETURN is pressed in response to the second input, the output will latch on at the specified switch-on time and remain on until the computer is reset or turned off.

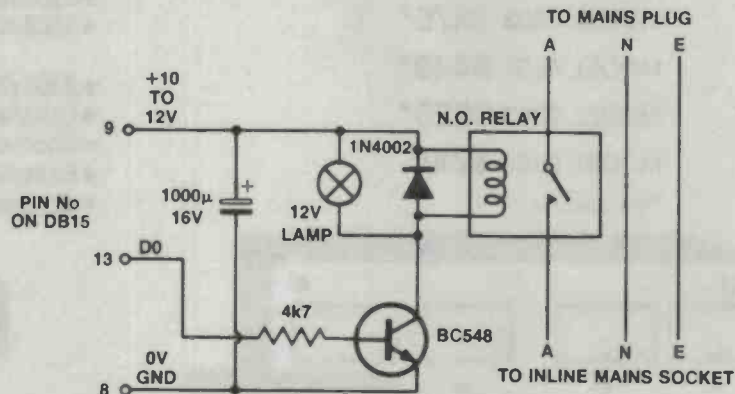

```

00100 REM Microbee appliance timer
00110 REM By Sean Machin, 18/1/86
00120 REM Initialize port #0 for output
00130 OUT 1,207:OUT 1,128
00140 REM Deactivate output
00150 OUT 0,0
00160 CLS:IN#0ON:POKE162,30:POKE163,128:POKE230,0:POKE220,15:SD8:CLR:UNDERLINE
:CURS 20,4:PRINT"Microbee appliance timer":NORMAL
00170CURS2,7:INPUT"At what time do you want the output on (HH/MM/SS)";A1$:IFA1$
=" "THENOUT0,1ELSEIFLEN(A1$)<>8THEN170ELSELETH1=VAL(A1$(;1,2)):M1=VAL(A1$(;4,5)):
S1=VAL(A1$(;7,8))
00180CURS2,8:INPUT"At what time do you want the output off (HH/MM/SS)";A2$:IFA2$
<" "ANDLEN(A2$)<>8THEN180ELSELETH2=VAL(A2$(;1,2)):M2=VAL(A2$(;4,5)):S2=VAL(A2$(;
7,8))
00190 IF A1$="" :H1=999:M1=H1:S1=M1
00200 IF A2$="" :H2=999:M2=H2:S2=M2
00210 CURS 14,10:INPUT"Enter current time (HH/MM/SS)";T1$:IF LEN(T1$)<>8 THEN 21
0
00220 CLS:IN#0OFF:POKE220,85:IF IN(0)=1:CURS 28,10:PRINT"Output " :INVERSE:PRINT
"on"CHR(160):NORMAL ELSE CURS 28,10:PRINT"Output off"
00230 CURS 24,7:PRINT"time:"
00240 H=INT(VAL(T1$(;1,2)))
00250 M=INT(VAL(T1$(;4,5)))
00260 S=INT(VAL(T1$(;7,8)))
00270 CURS 29,7:PRINT [13 H]" "[13 M]" "[13 S]
00280 REM 1 second delay
00290 FORD1=1 TO 574.01:NEXTD1
00300 S=S+1:IF S>59:S=0:M=M+1
00310 IF M>59:M=0:S=0:H=H+1
00320 IF H>23:H=0:M=0:S=0
00330 IF H=INT(H1) AND M=INT(M1) AND S=INT(S1):OUT 0,1:CURS 28,10:PRINT"Output "
:INVERSE:PRINT"on"CHR(160):NORMAL:GOTO 270
00340 IF H=INT(H2) AND M=INT(M2) AND S=INT(S2):OUT 0,0:CURS 28,10:PRINT"Output o
ff":GOTO 270
00350 GOTO 270

```

Topward

MODEL 4303 \$475*

MODEL 4302 \$449*

MODEL 2303 \$229*

MODEL 2302 \$210*

*Plus Sales Tax.



Regulated DC Power Supplies

FEATURES:

- 4303 (4302) Triple Output — ± 30 volt/3A (2A) +5 volt 3/A
- 2303 (2302) Single Output — ± 30 volt/3A (2A)
- Constant voltage and current capability
- Short circuit protection
- Extremely low ripple and internal resistance
- Compact size

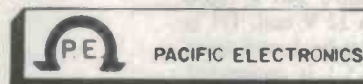

45 Wellington Street Windsor 3181
(03) 529 8500 Telex: AA 38432

DEALER ENQUIRIES WELCOME

ETI READER SERVICE 125

TEST AND MEASURING INSTRUMENTS

HANDHELD DMMs

Escort

Quality and reliability are the hallmarks of the Escort EDM-series. Hold one in your hand and you'll find that you can see and feel the pride and workmanship that goes into every Escort instrument.

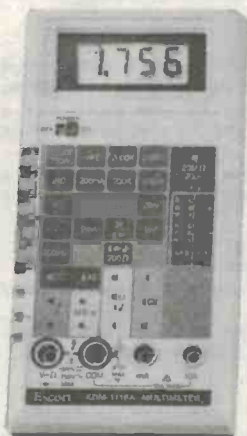

EDM-1116

EDM-SERIES

Common features:

- 200 mV-1kV DC
- 200 mV-750V AC
- 2mA-10A DC, AC
- Ohm 200 Ω -20M Ω
- Zener, Fuse & Positor protection

EDM-1105 3½ digit LCD, 0.8% accuracy	\$86
EDM-1116 3½ digit LCD, with transistor testing and capacitance ranges	\$115
EDM-1125 3½ digit LCD, 0.25% accuracy	\$125
EDM-1135 3½ digit LCD, 0.1% accuracy	\$162
EDM-1346 4½ digit LCD, 0.05%, true RMS	\$258

* All prices INCLUDE Sales Tax

Solderless Breadboards

- HIGH QUALITY, LONG LIFE NICKEL PLATED CONTACT CLIPS

A-TEK



B-012

\$12.65



B-124

\$29.90



B-135

\$43.70

Analog Multimeters from SEW

ST-350



ELECTRICIAN'S MULTIMETER

- Mirror scale
- 10A DC range
- V DC 10V-1kV
- V DC 10V-1kV
- A DC 0.5m-10A
- Ohm, dB, C, L

\$26.45

ST-380TR



WITH TRANSISTOR CHECKER

- Mirror scale
- Fuse & diode protection
- V DC 0.1-1kV
- V AC 10-1kV
- A DC 50 μ -250mA
- Ohm, dB, Buzzer

\$34.50



EMONA INSTRUMENTS

Division of EMONA ENTERPRISES PTY LTD

1st Floor
720 George Street,
Sydney 2000
Phone: (02) 212-4599

All correspondence to:
P.O. Box K720
Haymarket 2000
Telex: AA74500 EMONA

NSW Davred Electronics, Sydney. Phone 267-1385.
Geoff Wood Electronics Pty Ltd, Rozelle. Phone 810-6845.
VIC Radio Parts Group, Melbourne. Phone 329-7888.
QLD Baltec Systems Pty Ltd., Brisbane. Phone 369-5900.
Nortek, Townsville. Phone 79-8600.
WA Hincro Engineering Pty Ltd., Perth. Phone 381-4477.

ACT Electronic Components Pty Ltd., Fyshwick. Phone 80-4654.
SA Int's Communication Systems Pty. Port Adelaide. Phone 47-3688.
TAS George Harvey Electronics, Hobart. Phone 34-2233. Launceston. Phone 31-6533.

ETI READER SERVICE 126

WHEN THE CHIPS ARE DOWN . . .

You can't go far in electronics without knowing something about the 'chips' that form part of nearly every integrated circuit made today. In fact, you can't go far in everyday life without coming across them. So to catch up on these little pieces of electronics wizardry, read on . . .

Peter Phillips

ONE COULD BE forgiven for thinking that the integrated circuit is taking over the world! Many people wear them. Others wash their clothes and cook the evening meal unaware that an IC is adjusting the rinse cycle, controlling the temperature and probably whistling Dixie into the bargain.

The concept of the integrated circuit is a model of simplicity. In principle, an IC is just an electronic circuit in a small space. However, the contents of an IC cannot always be duplicated using discrete components on a printed circuit board. This is for various reasons, the most important one being that electronics is different when the components and the spaces between them are small. Also, as transistors are easily fabricated on to a silicon chip, the advantages of these devices over other passive components can be utilised. It is easier to etch in a hundred transistors than one inductor, for example, and the transistors can then be connected to simulate the inductor if required. In fact, where possible, IC designers use active rather than passive components, as this requires less space and provides an improved measure of performance.

The advantages of integrating the circuit components into a space that is measured in fractions of a millimetre are obvious. Paramount are the space and cost factors, with overall circuit complexity being reduced to a point that is often ridiculous. Couple this with the enhanced performance characteristics and ability to build in many more features, and it becomes clear why the integrated circuit is so popular.

Electronics can be classified as either digital or analogue. Digital electronics is becoming the norm, as particular advantages are available only with this type of technology. However, analogue electronics will always be a part of the field, and it is



Figure 1. The comparison of a simple planola roll and a record player recording explains the difference between the on-off digital concept and the linear analogue method.

this branch of electronics that forms the basis of this article. The digital aspect will be the subject of future parts of the series, in which digital integrated circuits will be discussed.

Analogue versus digital

Although analogue diehards may protest, it is fairly true to say that anything an ana-

logue circuit can do, a digital one can do better. Witness to this is the digital compact disc compared to the conventional record. Although many times more complex a CD-based system, often costing less than a top quality record player, offers facilities and performance impossible to otherwise obtain. Many analogies exist for comparing the two technologies and they usually pinpoint the performance characteristics of the digital circuit as being superior to the analogue counterpart.

The term 'analogue' comes from the idea of something being analogous to something else. In an audio amplifier the voltage being amplified is an analogy (has a similarity) to the sound that must be reproduced. As an example, a voltage can be a value that represents a mathematical quantity in an equation. In this way two dc voltages of say, 3 volts and 5 volts respectively, can each represent the numbers 3 and 5. Adding the voltages to give 8 volts means that a mathematical equation has been solved. The read-out would be a voltmeter, and the circuit to add the voltages in the first place would consist of amplifiers (called operational amplifiers) connected to allow addition to be performed. The whole thing would be simple to build, although the accuracy may not be better than five per cent.

Because the input signals have a linear relationship to the functions they represent, analogue electronics is often known as 'linear' electronics. The ICs that comprise this range are usually referred to as linear devices. Doing it 'digitally' usually means taking the original quantity, which will probably be an analogue form, converting it to a digital signal, and then processing it: Re-conversion to a linear form will often be required, as owners of a CD system will be aware.

The substrate is 96% alumina. Philips uses two sizes: 2" x 2" and 60 mm x 60 mm either 0.025 or 0.635 mm on 1.0 mm thick which can be prescribed to the desired size. This particular substrate has a 1" x 1" circuit on a 2" x 2" x 0.025" substrate.

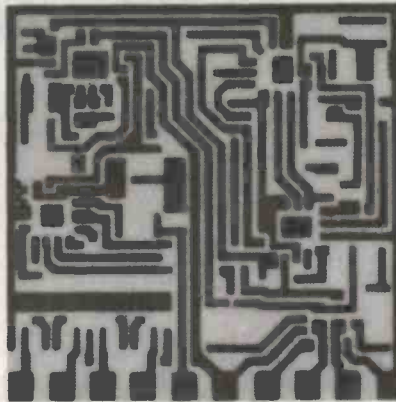

1 *Main Conductor Print.* Usually silver-palladium but may be gold or a combination of both. Track width and separation is usually 0.4 mm but 0.25 mm is not uncommon.

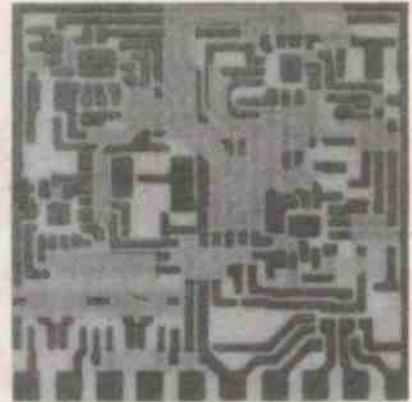

2 *Dielectric Print.* This is an insulating glass print which allows tracks to be printed over the first conductor print.

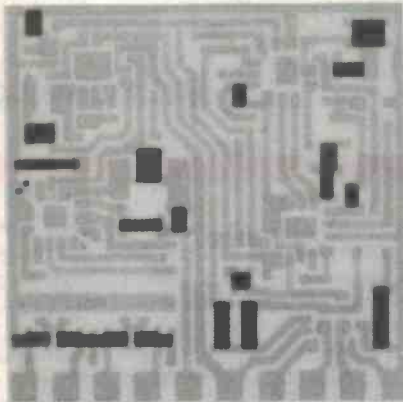

3 *Resistor Prints.* Pastes of ruthenium oxides are now printed. In this case only two pastes are printed, 1k ohms per square and 1M ohms per square, however, all decades from 10 ohms to 1M are available. All decades can be printed on one substrate but it is preferable not to have more than four different resistor pastes on one hybrid.

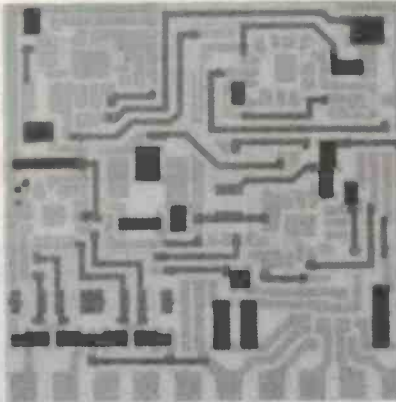

4 *Second Conductor.* In fact before the second conductor is printed a second layer of dielectric material is printed over the first to reduce the possibility of pin-holes causing shorts between first and second conductor. The second conductor print is made of the same materials as the first conductor but it is usually limited to track width and gap minimum of 0.4 mm.

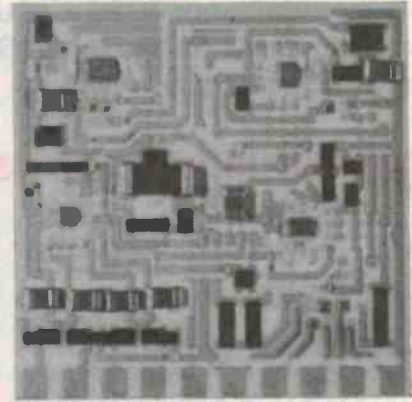

5 After the final print and firing (there are usually three or four firings at about 850°C for most hybrids) a silver loaded epoxy is printed on to the substrate and chip components are placed on the circuit. In this particular case this 1" x 1" hybrid has four CMOS ICs, eight chip capacitors (ceramic) ranging from a few pf to 100 nf, five diodes and three transistors. The active devices are then wire bonded with 25 μm gold wire. For power devices 38 or 50 μm gold wire can be used.

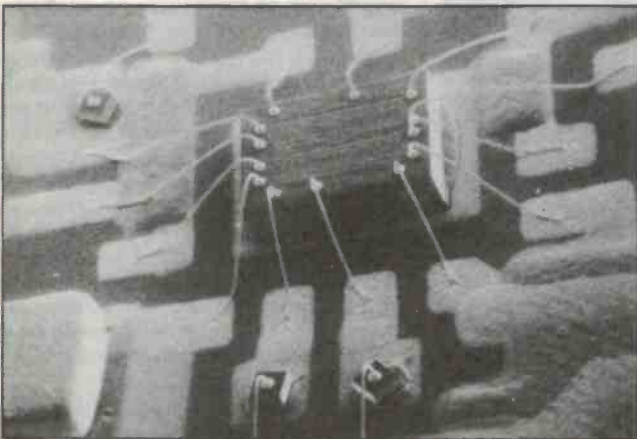

6 A wire bonded active device under electron microscope.

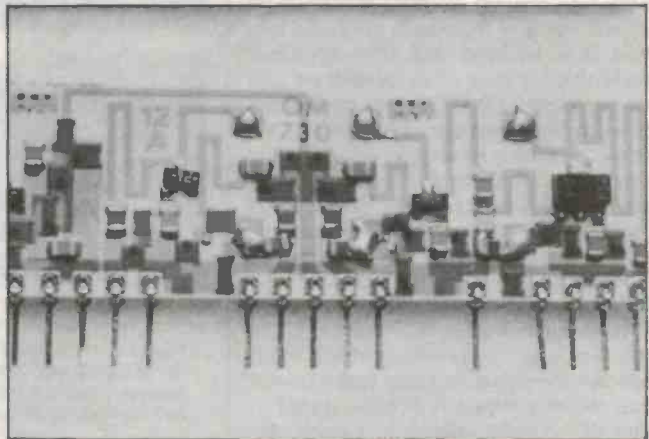

7 This photo shows the alternative to chip and wire assembly. This system used micromin on surface mounted components. Many conventional components are now available in small outline packages. These are soldered to the hybrid by using a screened on solder paste and then reflowing the circuit in a belt furnace. The two circuits shown are a logic circuit and an rf amplifier (the zig-zag tracks are inductors).

Laser Trimming. The value of the printed resistors is typically $\pm 20\%$ so often several resistors on a circuit will be trimmed either to a specific value ($\pm 1\%$ is common) or some parameter of the completed circuit will be trimmed, eg, the frequency of an oscillator or the voltage of a regulator.

After the circuits have been assembled the chips (if any) will be protected with an epoxy chip coating, pinned, cleaned, coated in an epoxy encapsulant and then tested before delivery to the customer.

Figure 2. Hybrid construction. (Courtesy of Philips.)

Perhaps the easiest example to illustrate the difference between the linear and 'non-linear' systems is to compare a piano roll to a record. Younger readers may not be familiar with a 'pianola' roll; suffice it to say that this means of recording is like a punched card, where a hole represents a note on the piano. An analogue recording of music played on a piano uses the familiar spiralling groove, the shape of the groove being determined by the sound it represents. It is possible to observe the groove under a microscope and determine the nature of the signal at the point being examined. The piano roll uses holes to play the required notes, and 'no hole' means 'no note'. Thus, the digital form is an on-off concept, where the analogue or linear method employs changing quantities to provide the electrical counterpart of the original information.

Linear ICs

Linear integrated circuits range from transistor arrays, amplifiers and voltage regulators, through to complete sub-systems. It is impracticable to discuss more than just a few of the more commonly used types. The ones most likely to be encountered by hobbyists are the amplifier and voltage regulator varieties. Another particularly useful IC is a timer. Readers may already be familiar with the popular 555 timer, and this IC will also be discussed.

Manufacturers provide databooks with information on all these devices. A linear databook is a useful adjunct to a technical library as apart from details of the ICs themselves, applications for them are often provided with sufficient information to allow the reader to build many useful circuits. Before discussing the individual ICs, some general information to provide a background on manufacturing techniques and packaging methods will be useful.

Manufacturing methods

The terms 'monolithic', 'thin-film' and 'hybrid' are often encountered in literature on the integrated circuit. These terms refer to the type of manufacturing method used. The monolithic construction method is the most common and means that the circuit is built into one semiconductor wafer. The term is derived from a combination of the Greek words *monos* (single) and *lithos* (stone). The process of manufacturing the IC requires that a single, highly polished slice of the semiconductor be exposed to a negative of the circuit design, with subsequent etching and diffusion processes producing the final result. The chip is then packaged, with the connections to the circuit being provided by way of 'legs' which are supported by the package.

Thin-film circuits are constructed on a flat plate of insulating material (for example,

glass or ceramic), which is known as the substrate. Then, by sputtering, vacuum evaporation, or other processes, thin layers of conducting, insulating or resistive material are deposited to form the wiring and passive elements in the circuit. Inductors are not usually included, due to the limited space available, and need to be connected as external components.

Thick-film devices are very similar, except a silk screening process is employed to deposit the components. These types of circuits allow a broader range of passive components because they have a higher tolerance than the monolithic construction, but they are usually larger.

To provide active components on a film type circuit, monolithic elements are added containing the required devices. This type of circuit is the *hybrid* type (hybrid meaning mixture). Another hybrid variety employs a monolithic element with a separate power transistor, packaged in the one case. Hybrid construction allows power handling circuits to be built, such as power amplifiers and high power voltage regulators.

Packaging and type numbers

Packaging of an IC depends largely on the function of the device. If the device must handle power, the case will need to dissipate the heat to a heatsink, usually requiring either a metal fin from the plastic case or an all metal case. For low power devices, various packages are used, the most popular being the dual in line (DIL) plastic case. Another commonly used case is the metal can, and many ICs are available in either type. A third variety is the flat pack. This package is designed for surface mounting on the pcb and is popular with manufacturers because drilling holes for the device is obviated, with a subsequent saving in cost. Devices having a military specification sometimes come in a ceramic DIL package, these devices having a wider operating temperature range.

Pin numbering is standardised for the DIL, flatpack and metal can packages. Figure 3 shows the way these case outlines have their pins numbered. Note that numbering proceeds in an anti-clockwise direction when viewing the case from the top, with pin 1 usually being the reference pin. The metal can always has pin 1 as the first pin to the left of the tag, again when viewed from the top. When looking at the pcb connections (track side), the numbering, being upside down, is in a clockwise direction. Pin identification is another matter, and ordinarily consulting manufacturers' data is the only way to determine which pin does what.

Identification of ICs is not standardised, although a registered type *number* for a specific IC will be used by all manufacturers of the particular chip. The most important part of an identification code is this number. Letters may precede or follow the number, and their meaning is dependent on the manufacturer. As an example, consider the device generally referred to as the 741. This device is an operational amplifier that is produced (second sourced) by most of the major IC manufacturers under licence to the original inventors.

National Semiconductor produces this device in four package styles, with two temperature range capabilities. An 8-pin DIL package with a commercial temperature range (0°C to 75°C) has the type number LM741CN. 'LM' means linear monolithic, 'C' refers to the temperature range, and 'N' the package type. Motorola uses the same code as National, but the same device from Fairchild is listed as a μ A741TC. From Signetics comes the μ A741CN; Texas Instruments calls it the μ A741CP. The list goes on, and because of the range of packages and operating temperature specifications, the letters following the numbers are used to differentiate between the various types. A linear hybrid IC, when produced by National Semiconductor is prefixed with 'LH', a lin-

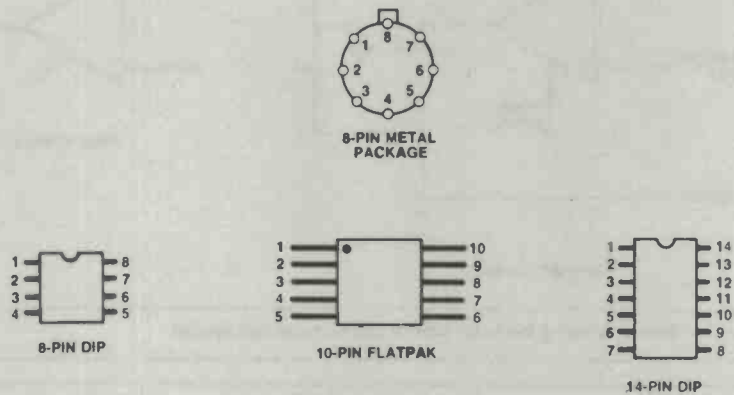

Figure 3. Pin numbering of IC packages.

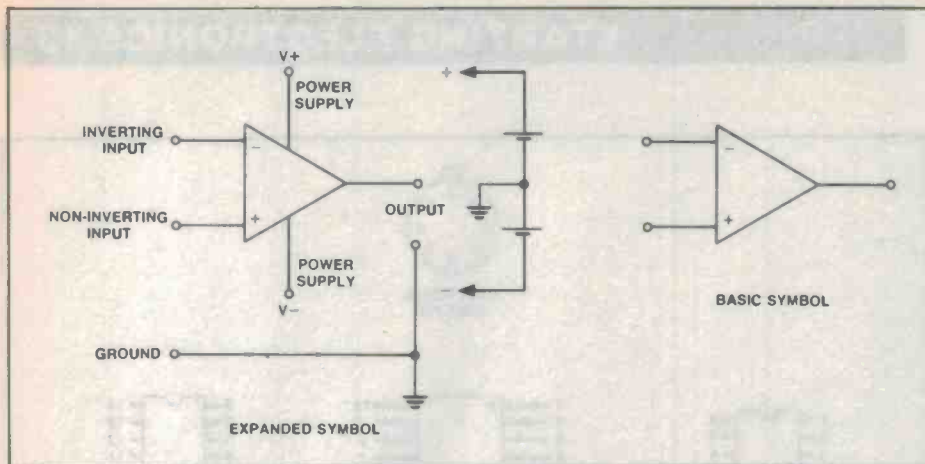

Figure 4. The op-amp, showing the basic symbol and an expanded symbol.

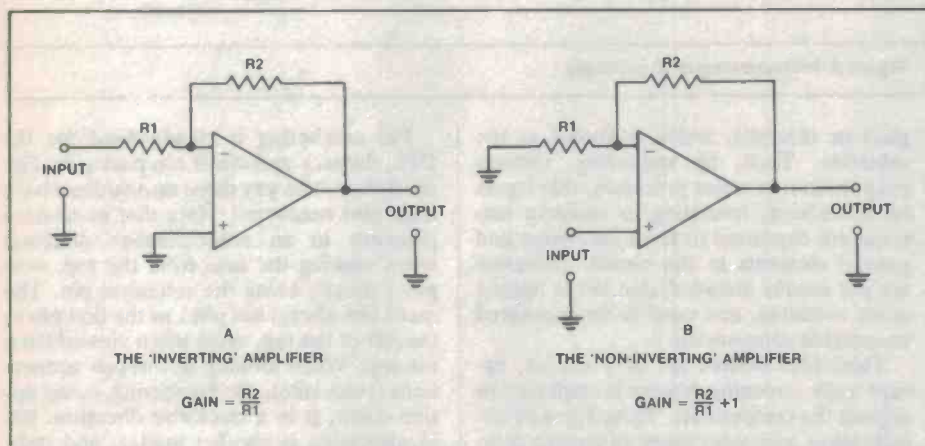

Figure 5. Op-amps as amplifiers.

ear FET device has 'LF', and so on. 'TBA' is sometimes used by National to indicate the same as 'LM', and a monolithic MOSFET device becomes 'MM'. Obviously the manufacturers' data manual is the best way to decode the lettering.

Operational amplifiers

The term 'operational amplifier' was coined as a result of its use in analogue computers. In this application, amplifiers are arranged to perform mathematical operations including addition, subtraction, integration, differentiation, multiplication, logarithms and so on. Early op-amps were constructed using valves and their versatility has made them popular. Not all amplifiers can be used as op-amps. An audio amplifier such as that used in a sound system would not qualify, although an op-amp can be used as an audio amplifier. So, what is the difference?

An op-amp is one that has operating characteristics that meet, or come close to meeting, a set of 'ideal characteristics'. These are: an infinite gain, an infinitely high input resistance, a zero output resistance and an infinite bandwidth. In practical terms this means that the gain of the amplifier is extremely high and that it can amplify signals ranging from dc to greater than

1 MHz. A high (preferably an open-circuit) input impedance means that virtually no current flows into the amplifier's input terminals from the signal source. A low (ideally zero) output impedance enables the amplifier to drive any load resistance without loss of output.

When an amplifier has these characteristics it can become part of a circuit, the operation of which is determined solely by the components around the amplifier. In other words, the circuit's operation is independent of the amplifier. Integrated circuit op-amps come very close to the ideal, so much in fact, that analysis of the circuit can assume the amplifier is ideal. A study of the theory associated with these interesting devices is beyond the scope of this article, but this does not prevent a brief look at a few common circuits.

The most common application for an op-amp is as an audio amplifier. Obviously a very high gain is a disadvantage for this use as distortion would be excessive. To reduce the gain to a practical value, negative feedback is used. Feedback is a common term in electronics and means applying a portion of the output signal back to the input. If the signal being 'fed-back' subtracts from the original input signal, thereby reducing the gain, negative feedback has been applied.

Positive feedback does the reverse and should be avoided. Most people are familiar with positive feedback in a public address system, which causes distortion and howling when the microphone (input) is too close to the speaker (output).

Negative feedback has other advantages, and most op-amp circuits use it in one form or another. Figure 4 shows the electrical symbol for an op-amp. Notice how there are two inputs, marked respectively '-' and '+'. The terminal marked '-' is known as the *inverting* input, and this means that the output signal is the opposite polarity to the input signal at this terminal. If a positive voltage is applied to the '-' input, the output voltage will be negative. The other input has the same polarity as the output and is known as the *non-inverting* input.

Because the output voltage must be able to swing both negative and positive, and allow a zero output for a zero input, op-amps need a special sort of power supply. This supply is known as a dual polarity power supply, and Figure 4 shows how this can be achieved with two batteries.

Op-amp circuits

Figure 5 shows two ways of connecting an op-amp as an audio amplifier with a gain determined by the external resistors. The equation to calculate the gain is given beside each circuit and, as can be seen, the amplifier has nothing to do with this value. Note that the non-inverting amplifier has a gain slightly higher than the inverting amplifier for an equal ratio of the resistors, ie by 1. Also, for correct operation, the signal source should allow a dc path to ground for the internal dc currents (called bias current) flowing out of the amplifier.

Many other functions can be achieved using the operational amplifier. Figure 6 shows two more circuits; the comparator and the summer. The comparator utilises the full gain of the amplifier, and provides an output voltage of either maximum positive or negative. The values will approximately equal the power supply voltages. The polarity of the output depends on whether the input at A is greater or smaller than the voltage at point B. For the circuit shown, if A is more positive than B, the output will be at the maximum negative voltage, or approximately the value of the negative supply. Vice versa if B is more positive than A.

The summer (or adder) circuit is used to add voltages, alternatively it can be used as an audio mixer. A particular advantage of this circuit is that one signal can receive more gain than another by simply altering the ratio of the resistors. A use in an audio application would be to mix the output of a microphone with that of a record player. Because the microphone has a much lower output than the record player it would need higher gain, and by adjusting the value of

the input resistor a satisfactory balance can be obtained.

Op-amp types

Op-amps come in a wide range of types, each having its own particular use or advantage. Like all integrated circuits, the internal circuit can be either comprised of transistors, JFETs or MOSFETs. FET or MOSFET construction offers the advantage of a high impedance with low power consumption transistors allowing higher power at the output. MOSFETs provide the highest impedance but may be fussy where static voltages can occur, causing their sudden unexplained demise.

Some amplifiers need the connection of external capacitors to provide frequency compensation to enable them to work at high frequencies, others like the 741 are internally compensated and don't require these components. However, internal frequency compensation generally results in a lower bandwidth, or range of operating frequencies. The gain for the circuits is listed in dB. A gain of 100 dB is equal to a voltage gain of 100,000, which means that an input of 10 microvolts gives an output of 1 volt. That's a high gain in any language!

A common op-amp is the 741, which is a general purpose device suitable for audio applications. Many devices share the same pin connections as the 741, and the pinouts for this device are included with Table 1. Some ICs offer several amplifiers in the same package, allowing a space saving on a pcb layout. The 3900 is one that provides four amplifiers in a 14-pin DIL pack, although this device is different to the conventional varieties. It uses a different operating principle which allows simpler circuitry at a cost in performance. However, for many audio uses the 3900 (or its equivalent) is a good choice, although the circuitry around the amplifier will be different from that shown in the examples.

In summary, the op-amp is a most versatile device and is used extensively in electronics. The coverage given these devices may serve to whet your appetite, and many texts are available at a low cost to allow the interested reader to pursue the topic.

Voltage regulators

The advent of the voltage regulator has heralded a new philosophy in power supply design. Gone are the complex circuits that required careful design and construction. Now, for less than a few dollars and a handful of components, it is possible to build a regulated power supply with specifications that often exceed those of the sophisticated circuits of yore. A regulated power supply is one that provides a constant output voltage to supply a circuit, regardless of input voltage or load current variations. Normally some form of overload protection is incorporated within the power supply regulator

to prevent damage to it or the circuit it is supplying in the event of a failure external to the regulator.

The three terminal regulator is the most common type, although some varieties use a 14-pin DIL package configuration and a more comprehensive range of features to allow the designer more flexibility in the design. A three terminal regulator is generally a device packaged in either a TO-3 or a TO-220 case. For lower power devices other smaller packages are used, allowing separate regulators to be placed around the circuit.

Voltage regulator ICs can be fixed voltage, either positive or negative output, or can form part of a variable supply. The 7800 series is a very common family of three terminal regulators, and provides a range of fixed positive output voltages at currents up to 1 amp. Where a negative output is required, the 7900 series is used. In both cases the last two digits of the type number indicate the output voltage. Thus, a 5 volt device is listed as a 7805, or 7905. A slight variation on this is the 7885 which has an output of 8.5 volts. The highest output volt-

age in either series is 24 volts, the lowest is 5 volts.

Figure 8 shows some details of these devices. Note that the pin connections for the 7800 series differ from those of the 7900 types. Normally an input voltage (unregulated) is chosen that allows at least 3 to 4 volts to be dropped across the device. The minimum differential is typically 2 volts, below which regulation ceases. The input can be as high as 35 volts, but the higher power dissipation may cause heating of the regulator, in turn causing the internal protection to operate, limiting the output current.

Although the 7800/7900 devices can be made variable by the addition of external components, the 317 regulator is designed specifically for this application. A fully regulated power supply, with an output voltage range of 1.2 volts to 37 volts at a current of around 1.5 amps, and featuring short-circuit and overload protection, can be constructed using this IC as the main element. Such a supply is an excellent piece of equipment for a workshop, and many designs using this regulator have appeared ▶

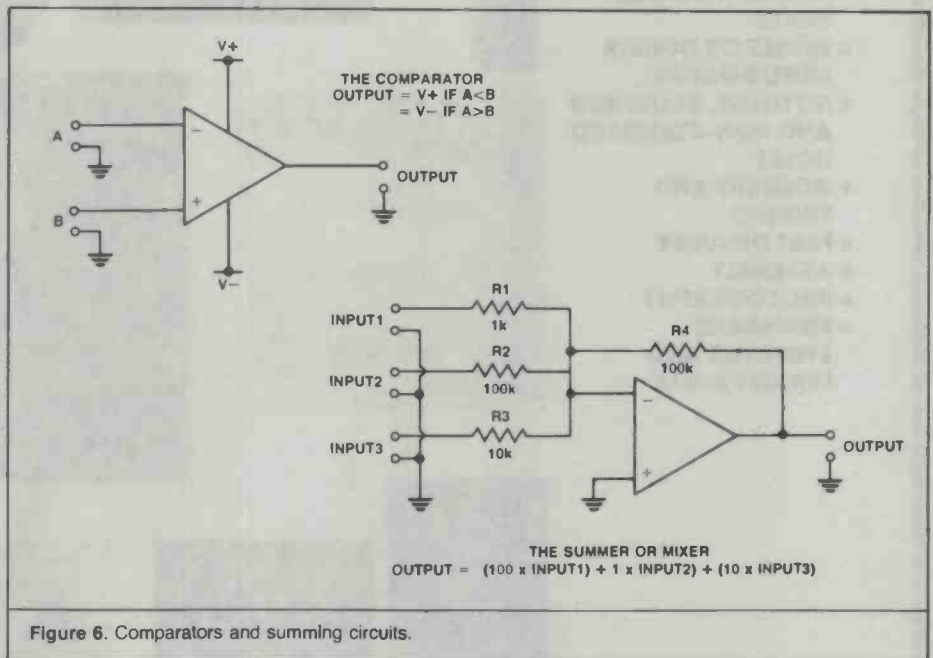

Figure 6. Comparators and summing circuits.

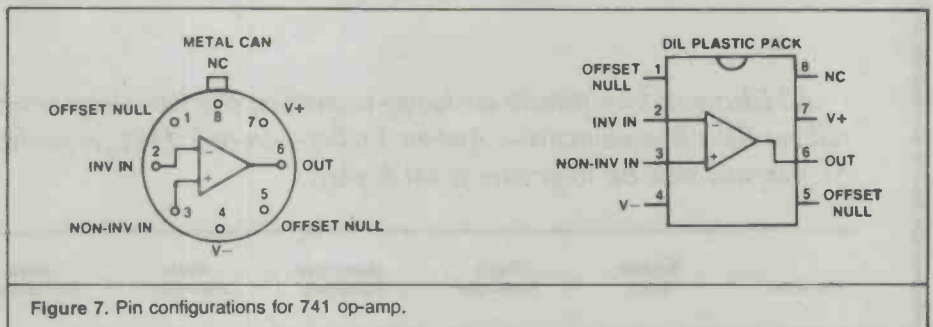

Figure 7. Pin configurations for 741 op-amp.

ALL ELECTRONIC COMPONENTS

Division of DOTHAIN Pty. Ltd.

118-122 LONSDALE STREET, MELBOURNE, VIC. 3000, Australia. Telephone 662 3506

After supplying kit Printed Circuit Boards and Front Panels for the past 22 years, All Electronic Components are proud to announce their distributorship of Jemal Products' P/L extensive range of quality goods and services—catering for Industrial, OEM and Hobby customers alike.

Jemal Products is one of Australia's most expedient producers of high quality printed circuit boards, panels, chassis and racks, plated through hole boards and assembly services.

- HIGH QUALITY P.C.B.s
- NOTATION AND SOLDERMASK
- PLATED THROUGH HOLES
- SINGLE OR DOUBLE SIDED BOARDS
- NOTCHES, STANDARD AND NON-STANDARD HOLES
- GOLDING AND TINNING
- FAST DELIVERY
- ASSEMBLY
- PHOTOGRAPHY
- MEMBRANE SWITCHES AND LEXAN PANELS

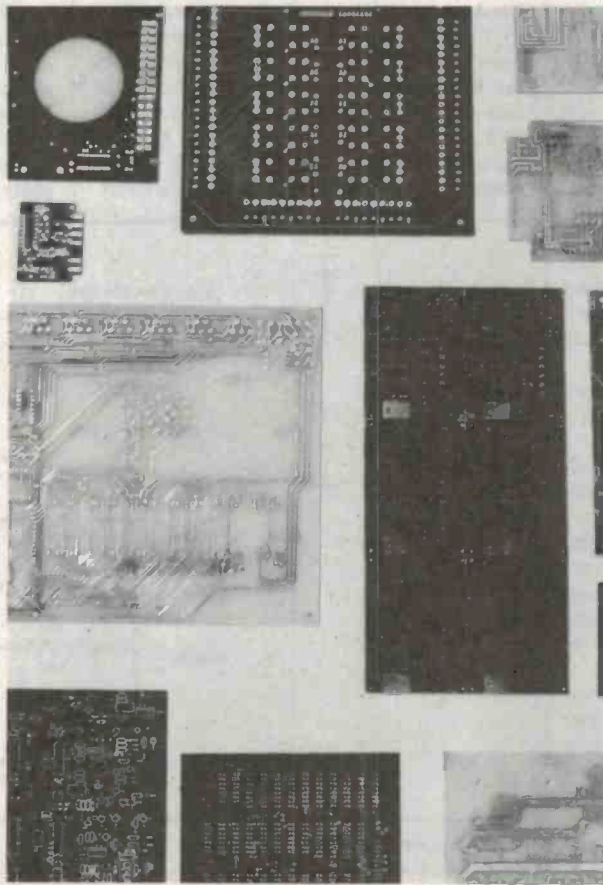

- CLOSE LIMIT METALWORK
- PANELS CAN BE PUNCHED AND PRINTED ON ALL SURFACES, INCLUDING POWDERCOAT
- ACRYLIC PANELS CAN BE ENGRAVED OR REVERSE PRINTED, AND WE CAN PROCESS PHOTO ETCHED PANELS IN ALUMINIUM, BRASS AND STAINLESS STEEL
- TOOLING
- PROTOTYPES

All Electronic Components are happy to quote on any job—large or small. Customers are invited to call our Sales Representative—Andrew Frolley—on 662 1381 for further details, or visit our Lonsdale St. store and view the impressive Jemal display.

Importers ◊ General Sales ◊ Radio Equipment ◊ Microwave Equipment ◊ Radar Equipment ◊ Pulse Techniques ◊ Industrial Electronics ◊ Instrumentation

over the years in various electronics magazines.

Worth a special mention is the 723 voltage regulator. This device spawned integrated circuit regulators in general, and comes packaged in either a 10-pin metal can, or a 14-pin DIL pack. This chip is intended to be used as part of a regulator circuit, although it can pass a current of 150 mA without any extra transistors. Normally a series pass transistor (one that passes the load current) is used with the 723, allowing currents of many amps to be handled. External components are added to create virtually any circuit required. Whole books have been written around this IC, giving designs for a wide range of applications.

Apart from the devices mentioned so far,

other regulators, either 3-pin or 4-pin, are available that can control currents up to 10 amps, again at a fixed or variable output voltage. The μ A78P05 is one such device, having a hybrid construction in a TO-3 case, and providing a 5 volt output at 10 amps. More involved, but commonly used in high power regulators where space is at a premium, are the switching regulator ICs. These devices form part of a circuit arrangement where high speed switching is used to control the output voltage. Typical low power chips are the μ A78S40 and the μ A494, or, where a device capable of supplying 5 amps is required, the SH1605 can be used. These regulators are more difficult to use, and hobbyists are advised to construct only known circuits, rather than design their own.

The famous 555 IC

When Signetics launched the NE555 timer IC on an unsuspecting world in 1972, it scooped the pool by simply producing the right IC at the right time. Prior to the 555, circuits that acted as timers in one form or another were made using an array of discrete components, perhaps with an op-amp or two thrown in as well. Since then, an array of timer ICs has resulted, some of these being duals, even timer/counter types. But still the 555 reigns supreme, exceeded in popularity only by the op-amp.

At first glance there is nothing particularly exciting about a chip that acts as a timer. However, if you look around you'll see the 555 at work just about everywhere. Creating sounds, flashing a warning light on a car dashboard, generating all kinds of timing pulses, acting as a delay before arming an alarm system, controlling model trains, allowing a joystick on a computer to position the 'laser' beam to shoot aliens — the list is endless. The 555 is now second sourced by most IC manufacturers, and mass production has resulted in a cost of around 40 cents.

A timer is merely a device that does something after a predetermined delay period. In the 555 IC, external components are used to set the delay, and the output will respond by going 'high' during this period and 'low' after it. This function is known variously as a 'one shot' or a *monostable* multivibrator. By modifying the basic timer circuit, the output can be made to alternately go high and low continuously, forming the *astable* multivibrator. The delay time can range from fractions of a second to hours, simply by changing the values of the timing components.

As with the op-amp, books on the 555 are available, detailing hundreds of applications for this device. Understanding how the 555 works is relatively easy, and more technically advanced readers who wish to experiment with this chip would benefit greatly by obtaining such a book. Using this device is also fairly simple, as unlike many ICs the power supply is not critical and only a few external components are needed to make the thing perform. Perhaps the 555 is the best way to 'get started' with integrated circuits.

In conclusion . . .

The subject of integrated circuits could fill volumes, so obviously we haven't been able to cover everything in this article. No mention has been made, for example, of ICs that form whole power amplifier modules, or complete radios, let alone all those fancy chips that allow pocket sized TV sets and cassette players. But hopefully we have triggered your imagination, removed some of the mysteries, or just made you thirst for more. At least it's a start!

THREE TERMINAL REGULATORS

Type	Polarity	Case	min	V _{OUT} typ	max	I _{OUT} (nom)	Dropout Voltage
7805	positive	TO-220	4.8	5	5.2	1 A	2
7812	positive	TO-220	11.5	12	12.5	1 A	2
7815	positive	TO-220	14.4	15	15.6	1 A	2
7905	negative	TO-220	-4.8	-5	-5.2	1 A	1.1
7912	negative	TO-220	-11.5	-12	-12.5	1 A	1.1
7915	negative	TO-220	-14.4	-15	-15.6	1 A	1.1
LM317K	positive	TO-3	adj	1.2 to 37		1.5 A min	
LM317T	positive	TO-220	adj	1.2 to 37		1.5 A min	
78H05	positive	TO-3	4.85	5	5.25	5 A	2.5



NOTE: 1) PLACE C1 AND C2 AS CLOSE TO REGULATOR AS POSSIBLE
2) XX = VOLTAGE VALUE

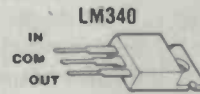
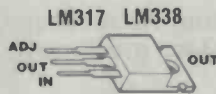
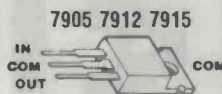
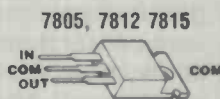

Figure 8. Pin connections for voltage regulators and circuit for using a 7800 series regulator.

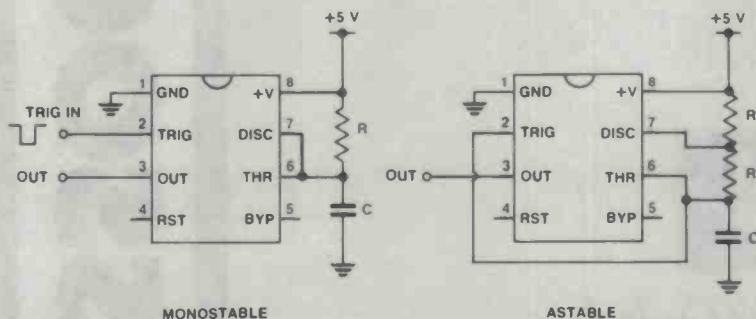

Figure 9. The 555 timer.

Counters that just count And counters that do much, much more



Years ago when your design called for an event or quantity counter you specified a simple electromechanical counter and it did the job.

Now in this age of technology there are still thousands of applications where this type of counter is still the best economical and functional choice.

Our range of Kubler electromechanical counters is so extensive you'd be hard pressed to come up with a job they can't handle. Kubler counters have moved with the times too. Today they are precision built for even more reliability. Your choice has opened up to multi-dial

versions, AC or battery operation, manual or electric reset, a range of triggering options and even to pneumatic versions for those dangerous environments.

Unlike those old days you can now get electronic and microprocessor versions for those more sophisticated applications where computer interfacing is needed.

Kubler counters, an old idea moving with the times and still making sense.

So if you need to count or measure economically call us for a brochure on Kubler counters.



Associated Controls

In Sydney call Dorothy or Barbara on (02)709 5700
In Melbourne call Jennifer or Sandra on (03)561 2966
In Adelaide call Paul or Jeff on (08)297 2033

ASSOCIATED CONTROLS

INDEX 1985

AUDIO

	Date	Page
CD players: the developments go on with breathtaking speed (L. Challis)	May	18
Hi-fi in 1985 — a revival (J. Fairall)	May	12
Hi-fi in 1985 (L. Challis)	Sep	supp
1985 CD player comparison (L. Challis)	Dec	19
Sony steals a march with the 'CD Walkman' (D. Lingane)	Jan	41

COMMUNICATIONS

Albanian broadcaster (A. Cushen)	Jun	121
Aussat nearly comes to Ravenshorpe (M. Goldfinch)	Jul	126
Aussat: upwards with myth (J. Fairall)	Nov	122
Adventist World Radio broadcasts from Italy (A. Cushen)	Oct	102
BBC programmes in focus (A. Cushen)	Sep	94
BMAC — we'll be first to use it (J. Fairall)	Mar	10
Broadcasting from inside tunnel (A. Cushen)	Aug	100
Catching those elusive signals (A. Cushen)	Nov	96
Christian Science Monitor joins broadcasters (A. Cushen)	Dec	107
Commercial shortwave radio (A. Cushen)	Jul	116
Cruising the Pacific for ANZCAN (M. Rennie)	Apr	110
Direct sound broadcast satellites (A. Cushen)	Jun	119
DX sessions — the fast way to find out what's happening (A. Cushen)	Mar	110
Fixing the VHF/UHF broadcast bungle (J. Fairall)	Jan	24
Gabon relay captures audience (A. Cushen)	Sep	95
Getting started on the higher frequencies (A. Cushen)	Aug	116
Halley's could disrupt radio signals (A. Cushen)	Sep	94
How good is your transceiver? (D. J. Williams)	Aug	102
Improved gospel signals (A. Cushen)	Sep	95
Kilohertz comment (A. Cushen)	May	111
Kilohertz comment (A. Cushen)	Jun	120
Kilohertz comment (A. Cushen)	Jul	117
Kilohertz comment (A. Cushen)	Aug	101
Kilohertz comment (A. Cushen)	Sep	96
Kilohertz comment (A. Cushen)	Oct	102
Kilohertz comment (A. Cushen)	Dec	106
One hundred years of time zones (A. Cushen)	May	110
Overseas relays (A. Cushen)	Oct	101
Progress at BBC sites (A. Cushen)	Oct	100
Radio Japan (A. Cushen)	Dec	107
Reception report (A. Cushen)	Sep	100
Red Cross radio (A. Cushen)	Dec	106
Satellite TV smorgasbord (J. Fairall)	Jan	36
Satellites mean the BBC sounds better (A. Cushen)	Aug	99
Satellites over Australia (J. Fairall)	Nov	12
Scanners (J. Fairall)	Dec	12
Shortwave Babel — listening to language broadcasts on shortwave (A. Cushen)	Jan	107
Shortwave stations forced to use allocated channels (A. Cushen)	Aug	98
Spy stations make intriguing listening (A. Cushen)	Mar	117
Sri Lanka — host to international broadcasts (A. Cushen)	Aug	100
113 MHz band to be created (A. Cushen)	Mar	117
Touring Aussat (J. Fairall)	Oct	114
Two thousand kilowatts from under the sea (A. Cushen)	Jul	125
UTC and local times (A. Cushen)	Jul	116
VOA helps listeners (A. Cushen)	Jul	115
VOA picks up reduced BBC audience (A. Cushen)	Apr	102
VOA's Caribbean services (A. Cushen)	Oct	101
World time stations give accurate information (A. Cushen)	Jul	114

COMPUTING

Compulsive programmers — an alternative view (M. A. Shotton)	Jun	125
Computer graphics — exploring in the dimensions of illusion (J. Fairall)	Apr	14
Data communications — the search for the ultimate transmission (J. Fairall)	Oct	20

Focus on Microbee (J. Rowe)	Aug	supp
Forth . . . a computer language for hackers (T. Moffat)	May	90
Keyboard encoder (A. Cousins)	Jun	107
Keyboard upgrade for the Microbee (J. Blanchard)	Jan	116
Low cost program gives full VZ200/300 full level II BASIC (J. Rowe)	Nov	94
More Chatterbox applications (T. Moffat)	Mar	96
Story of Dulmont (J. Fairall)	Jul	132
VZ200 video hardware interrupt (S. Olney)	May	99

COMMODORE & VIC-20

Artistic Vic	Nov	92
Baby elephant walk	Aug	90
Bill's brackets	Jul	98
Budget plan	Jun	115
Chain	Nov	93
Computer calendar	Jan	124
Computer derby	Jun	114
Dec-hex	Jun	115
Donkey Kong Pts 1,2,3	Apr	97
Envelope generator	Jul	99
Graph sketch	Sep	92
Graphics clock	Mar	104
Hexagon	Sep	92
Joystick controller	Mar	105
Lava river	Nov	93
Music catalogue	Aug	90
Mystery ship	Mar	104
Rock rally	Feb	114
Save it	Jul	99
Scramble	Apr	96
Using the user port	Nov	93
Vicdump	Feb	114
Video title board	Feb	115
Word sort	Feb	115

MICROBEE

Alarm clock	Sep	88
Boggle	Jul	94
Cannon	Nov	91
Circle	Jul	95
Combat battle game	Aug	94
Converter (The)	Feb	116
Cursor	Sep	88
Day	Feb	116
Eclipse predictions	Oct	85
Electronic circuit processor	Jul	95
Electronic tuning fork	Jun	111
Emphasised type	Oct	85
ETI-638 modification	May	104
False keyboard	Sep	88
Graphics creator	Feb	117
Home alarm control	Apr	94
Interrupting the interrupt	Dec	101
Life	Apr	95
Pasteurised sentences	May	105
Reaction time	Dec	101
Screen dump	Nov	90
Simpson's method	Dec	101
Speed changer	Apr	94
Star driver	Aug	94
Sun	Feb	116
Tennis	Nov	91
Three dimensional bar graphs	Dec	100
Topsyturvy	Oct	85
Trapdoor	Sep	89
Turbine	Jun	110
Undo utility	Dec	101

MICROCOMPUTER

Dynachromics generator	Apr	93
------------------------	-----	----

ELECTRONICS SHOW

	Date	Page
IREECON 1985 (J. Fairall)	Sep	80
Japan Inc — long live new media (D. Lingane)	Jan	16
Perth CES (D. Kelly)	Oct	16
Summer CES (J. Fairall)	Aug	12

ELECTRONIC TECHNIQUES

CROs — a closer look (J. Fairall)	Feb	40
Computerised circuit analysis (L. Wilson & J. Fairall)	Feb	103
Cutting the cost of chip design (R. Harrison)	Jan	6
Ferromagnetic cores in rf circuits (R. Sanders)	Nov	106
In-circuit emulation (J. D. Ferguson)	Mar	32
Keeping the message clear — transmission of digital data (T. Murphy)	Feb	81
Megatest: challenging the IC testing giants (J. Rowe)	Apr	28
Sizing up signal generators (J. Fairall)	Jul	12

GENERAL

Index 1984	Apr	114
Made in my image (M. Goldfinch)	Feb	16
Silicon Glen (J. Fairall)	Nov	124
Strategic defence initiative (J. Fairall)	May	114
The house that Clive built (J. Fairall)	Sep	116

IDEAS FOR EXPERIMENTERS

A-D for the 'Bee	Jun	92
Alpha lock for the 'Bee	Sep	75
An auto-answer facility	Mar	85
Binary display	Dec	86
Capacitance tester	Feb	98
Car computer modification	Oct	48
CMOS 80M transmitter	Mar	84
Contact material	Feb	99
Darkroom timer	Jan	101
Dual tracking power supply	Jun	93
Electronic organ	Oct	80
ETI-1405 mod	Aug	82
ETI-574 modification	Jul	110
Flasher	Feb	98
4-channel 4-track mixer	Apr	82
Giving Fluke the willies	Nov	49
Headlight delay and reminder	Jan	100
Headlight warning	Feb	99
Home computer control of model trains	Jan	100
Improving ETI-660 video output	Nov	49
Indicators	Dec	87
Mic lead tester	Oct	81
Microbee battery switch	Nov	49
Microbee joystick auto fire	Nov	49
Microbee volume control	Sep	74
Motor car light controller	Apr	83
Multi-sided gaming die	Jul	111
Nicad battery charger	Jun	93
Nine position joystick	Feb	98
Noise gate	Oct	81
Peripheral switch	May	82
Pulse-width modulated motor drive	Aug	83
Simple electronic metronome	May	82
Sound effects generator	Aug	83
Sound light unit	Oct	81

LAB NOTES

Good connections with soldering and wirewrap	Oct	supp
Starting electronics 5: Making your own pc boards (I. Thomas)	Jun	48
Starting electronics 6: Know your passive components Pt 1 (P. Phillips)	Aug	123
Starting electronics 7: Know your passive components Pt 2 (P. Phillips)	Sep	108
Starting electronics 8: Making the right connection (P. Phillips)	Oct	92
Starting electronics 9: Electronic hardware (P. Phillips)	Nov	116
Starting electronics 10: Getting active on solid state (P. Phillips)	Dec	116

PRODUCT REVIEWS

Akai CDM88T CD player (L. Challis)	Dec	19
Commodore Plus/4 (M. Lingane)	Feb	119
Creative Technology CPA-80 printer (J. Rowe)	Mar	93

Denon digital audio check CD II (L. Challis)	Sep	33
Dick Smith Q-1280 CRO (N. Hancock)	Oct	119
DSE VZ300 (J. Rowe)	Jul	102
Eclipse computer ECS-186 (G. Nicholls)	Oct	88
Eurovox MCC 2360E AM/FM stereo radio/cassette (L. Challis)	Nov	30
Gould 1421 CRO (R. Irwin)	Dec	40
Hewlett-Packard PC Instruments System (R. Irwin)	Sep	20
Hitachi DA-501 CD player (L. Challis)	Dec	19
Icom IC-R71A scanner (R. Harrison)	Jan	105
Icom IC-735 HF transceiver/receiver (P. Williams)	Oct	108
JPW P1 speakers (L. Challis)	Jan	47
JVC KD-V400A stereo cassette deck (L. Challis)	Aug	20
JVC's VideoMovie camcorder GR-C1 (M. Goldfinch)	Feb	36
Kenwood DP-840 CD player (L. Challis)	Dec	19
Marantz CD44	May	32
NAD 7155 receiver (L. Challis)	Feb	29
Philips CD 304 CD player (L. Challis)	Nov	26
Philips KR684 stereo TV	May	38
Philips' VR 6940/75 stereo VCR (L. Challis)	Jul	34
Pioneer KE-A433 AM car stereo/radio cassette (L. Challis)	Sep	36
Pioneer PD 5010 (BK) (L. Challis)	Dec	19
Power Sonic Nicad batteries (J. Scott)	Feb	48
QED A230 amp (L. Challis)	Apr	39
Seiko TUC-2000 wristwatch computer (J. Scott)	Jun	102
Sharp maths package for PC-1401 (R. Irwin)	May	94
Sony CDP-30 CD player (L. Challis)	Dec	19
Sony APM22ES loudspeakers (L. Challis)	Jul	26
Sony D50 CD player (L. Challis)	Mar	20
Sony ICF 2001D receiver (P. D. Williams)	Dec	110
Sony KV-2064EC stereo TV (L. Challis)	May	38
Sony Video 8 model CCD-V8 (L. Challis)	Oct	29
Spectrum SP7 loudspeaker (L. Challis)	Apr	46
Teac R-555 stereo cassette deck (L. Challis)	Aug	28
Technics SA-R100 stereo radio/cassette (L. Challis)	Jun	18
Technics SB-R100 wall-mounting speakers (L. Challis)	Jun	26
Technics SU-V6X integrated amplifier (L. Challis)	May	25
Yaesu FT 726R VHF/UHF transceiver (P. D. Williams)	Aug	106
Yamaha A-320 amplifier (L. Challis)	Oct	36
Yamaha CD-3 CD player (L. Challis)	Dec	19

PROJECTS

168 Versatile continuity tester (I. Thomas)	Sep	68
169 Low distortion audio oscillator Pt 1 (I. Thomas)	Oct	54
169 Low distortion audio oscillator Pt 2 (I. Thomas)	Nov	78
170 Precision CRO calibrator	Feb	74
182 Digital luxmeter (P. Ihnat)	Mar	58
183 Op-amp tester (R. Irwin)	Apr	74
251 Op-amp power supply (R. Irwin)	Aug	53
279 Darkroom exposure meter (P. Ihnat)	Jan	91
280 Low battery voltage indicator (R. Irwin)	Mar	66
341 Electronic jumper leads (I. Thomas)	Aug	60
342 Improved CDI — using shaped pulses Pt 1 (I. Thomas)	Feb	62
342 Improved CDI — using shaped pulses Pt 2 (I. Thomas)	Mar	72
343 Optical car alarm switch Pt 1 (S. K. Hui)	Sep	52
343 Optical car alarm switch Pt 2 (S. K. Hui)	Oct	70
664 Hobbybot navigating robot Pt 1 (A. Branch)	Nov	60
664 Hobbybot navigating robot Pt 2 (A. Branch)	Dec	78
665 Computer routing switch (N. Hancock)	Oct	63
666 Parallel printer switch (G. Nicholls)	Feb	92
667 Printer sharer (G. Nicholls)	Apr	66
677 Chatterbox computer voice synthesiser (T. Moffat)	Jan	74
679 Microbee joystick adaptor (G. Nicholls)	Jun	68
684 Intelligent modem Pt 1 (S. K. Hui)	Dec	54
692 RS232 to 20 mA current loop interface (G. Nicholls)	Jan	68
693 Tape auto-search (P. Phillips)	Jun	74
694 Low cost Forth development system (P. Ihnat)	May	72
695 VZ200 terminal	Aug	72
696 RSC-Forth card extension (S. K. Hui)	Dec	62
698 Experimental Microbee dialler (G. Nicholls)	Jul	78
699 300 baud direct connect modem (G. Nicholls)	May	54
741 10-channel radio microphone Pt 2 (I. Thomas)	Jan	84
742 'Speech-tailored' communications speaker (R. Irwin)	Feb	83
743 25 watt UHF power amplifier (S. K. Hui)	Jun	58

	Date	Page
751 Miniature FM transmitter (S. K. Hui & J. Fairall)	Dec	48
757 Fax/RTTY decoder for the Cat computer Pt 1 (A. Keir & R. Irwin)	Nov	70
757 Fax/RTTY decoder for the Cat computer Pt 2 (A. Keir & R. Irwin)	Dec	72
1401 Sonics active DI box (R. Irwin)	Sep	60
1404 Four channel mixer (R. Irwin)	Jul	58
1405 Stereo enhancer (R. Irwin)	Mar	50
1507 Light bulb saver (R. Irwin)	Nov	52
1526 Fibre optic link (P. Ihnat)	Apr	56
1527 Home burglar alarm module Pt 1 (R. Irwin)	May	64
1527 Home burglar alarm module Pt 2 (R. Irwin)	Jun	84
1528 Intelligent door controller (S. K. Hui)	Jul	67

SHORT CIRCUITS

Energy saver for car air-conditioning (E. Eulenstein)	Jun	96
---	-----	----

TECHNOLOGY

Custom chips, the new generation of (J. Fairall)	Jun	12
Little electric store — capacitors (J. Fairall)	Sep	10
Light on optical fibres (J. Fairall)	Apr	24
Supercaps (J. Fairall)	Mar	39
The charge ahead (J. Fairall)	Dec	124

VIDEO

The bird's eye view — 8 mm video (J. Fairall)	Oct	10
---	-----	----

NOTES AND ERRATA 1985

Project 153, temperature adaptor for DMMs, June '83: Note at the end of the parts list says that a 5V6, 1 W zener can be substituted for the original. This should actually read 5V1, 1 W.

Project 183, Op-amp tester, April '85: The battery polarity was shown reversed in the original circuit diagram. The correct polarity is shown herewith.

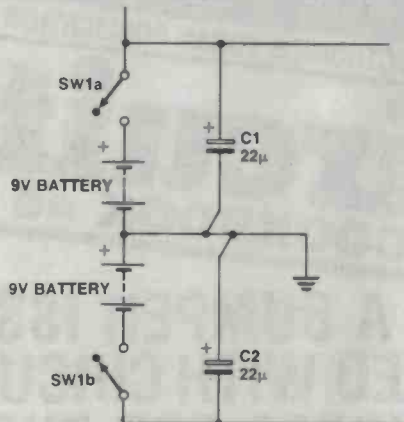

Project 251, Op-amp power supply, August '85: A major blunder as the overlay was inadvertently reversed. It is reproduced correctly in ETI September '85, p9.

Project 342, Improved CDI, February '85: The circuit diagram should have shown R8 as 220k not 220R.

Project 662B, Microprocessor-based timer/controller, April '84: On the circuit diagram for this project, page 74, the pushbuttons are labelled incorrectly. The correct positioning is detailed in ETI June '85, p8. Other minor corrections are: pin 20 of the 24-pin DIL plug is the PA7 connection. PB4 is on pin 9, not pin 15 as shown. IC1, pin 1, should be pulled down to ground.

Project 667, Chatterbox voice synthesiser, January '85: On page 76 the input connection attached to pin 6 of IC2c should be labelled STROBE-bar. The corresponding Centronics connector pin number should also be 1, not 10, while the Centronics pin number for the BSY output line should be 11 not 1.

If the Chatterbox is to be used with a VZ200 computer, capacitor C1 should be reduced to 100p to allow the circuit to trigger reliably from the narrower strobe pulse. Note also that the BASIC interpreter normally sends a CR-LF combination to the printer when returning to READY after running a program. This causes the Chatterbox to produce a continuous sound, even if your program leaves it silent. The solution is to end your program with a dead loop line (eg 1000 GOTO 1000), and break it using the CTRL + BREAK keys.

Project 1405, Stereo enhancer, March '85: In the stereo enhancer circuit it is necessary to buffer the metering circuitry from the main signal path. It was originally intended to put the buffers on the meter board but due to layout requirements it was decided that the main board was better. Unfortunately in the melee the buffers were deleted from the meter board but never reinstated on the main board. To fix this, an op-amp will have to be inserted between the main board and the meter board. The circuit and board are shown below. The small board mounts on two of the meter board mounting bolts on the right hand side (looking from the front). The positive supply and earth to the buffer can be taken from the meter board supply pins. The negative supply can be taken from the junction of C4 and IC2. The values of the two caps on the reverse side of the meter board should be dropped from 220n to 22n.

Also, the pin numbers from IC5 and the component numbers for R4, R7 and C7, C10 were marked incorrectly on the circuit diagram. The overlay is correct.

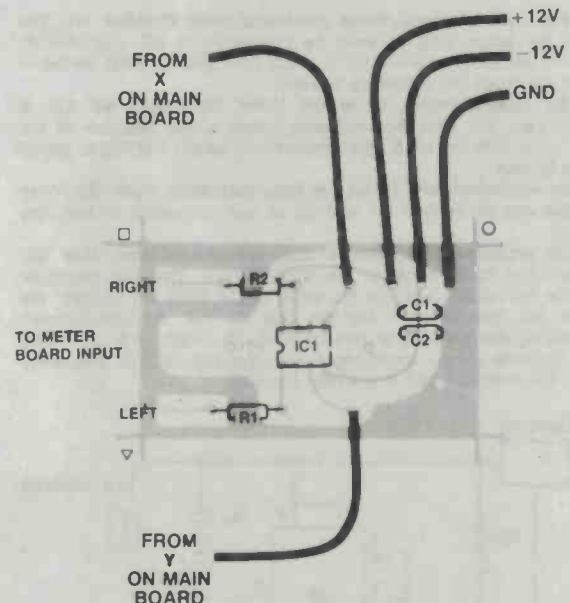
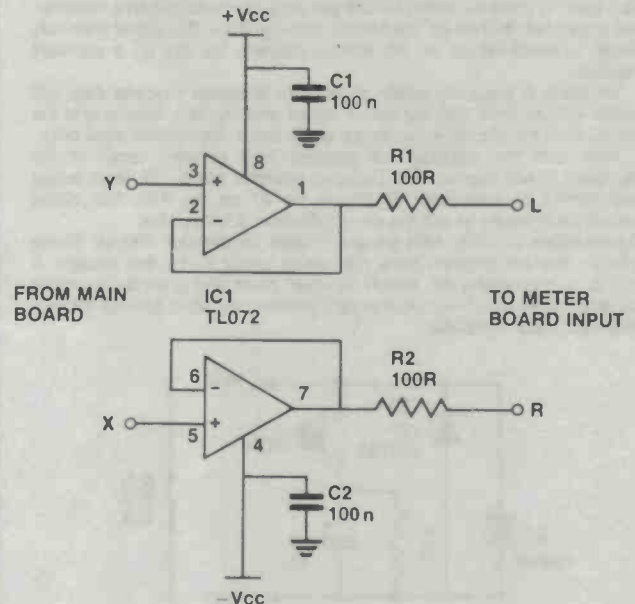

Project 1410, Bass guitar amp, September '84: The cut-off frequency of the filter network on the limiter output board is given

$$F_c = \frac{\pi}{2} (RV11 + R69 \times C6S)$$

INDEX 1985

This is incorrect. The CORRECT formula is:

$$f_c = \frac{1}{2\pi (R_{V11} + R_{69}) \times C_{55}}$$

Series 5000, Stereo control preamplifier, October '81: Just to prove that we do care, ETI staffers often (sometimes) build up projects for their own edification. One of us recently decided to build the series 5000 preamplifier, and spent a frustrating day trying to set up the level meters using the on-board oscillator. (Does this sound familiar?) Turns out the overlay, printed p 38 October 1981, shows R53 and R52 as 220 ohm. The circuit diagram and the parts list show 220k, which is the correct value. This mistake does amazing things to the input resistance of the line amplifier. The moral of the story: check parts lists, circuit diagrams and overlays for inconsistencies.

Banish that bad load, September '84: Max Maughan, engineering manager of Microbee Systems has advised that the idea of "Banish that bad load" is good for microphone input on a standard cassette recorder, but under test by him on the Micron data cassette, the signal was very weak; it would reload on the Micron cassette but not on a standard recorder.

Microbee is presently selling a Datatree computer cassette data unit which will not work with the circuit added and this is a reason why the output from the Microbee cannot be set to suit a microphone input only.

Also, with the Datatree the cassette load or input circuit in the Microbee is not needed. The Datatree cassette has a TTL level output and cannot be connected directly to pin 27 on the PIO. The circuit cannot be changed to suit the one application, advises Max.

Commodore column, C64 program hints September '84: Mr Morris advises that his program hints are not as useful as he first thought. If you fit a 'momentary-on' switch between reset and ground you might damage some ICs. This circuit should perform the reset function without destroying your computer.

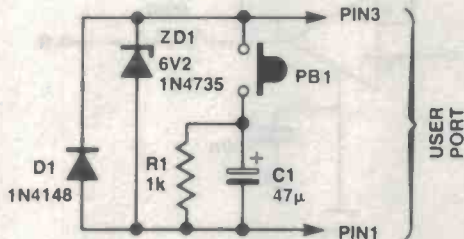

Ideas for experimenters, Pulse generator mod, October '84: The pole of the upper switch should be connected to BC (SQUARE(3) OUTPUT), switching between pin 7 of IC2 (BB) and the BNC socket — which is the Input, not output, as labelled.

Ideas for experimenters, Darkroom timer, December '84: IC2, a 74LS90, does not give the necessary clock output because of not enough drive from the 4018. The solution is to tie pin 1 of IC2 to ground via a 1k resistor.

Ideas for experimenters, Motor car light controller, April '85: Peter Hill's idea was drawn with Q1 and Q2 as npn transistors. In fact they are pnp's.

Ideas for experimenters, Simple electronic metronome, May '85: There are two minor errors in the printed circuit. The 3.3µF capacitor should be connected between the wiper of the 500k log pot and the negative rail, not between the pot and the rail. An improvement suggested by the author is to connect a 10nF cap from pin 5 of the 555 to the negative supply improving noise immunity to high frequency pick-up. The revised circuit is reprinted herewith.

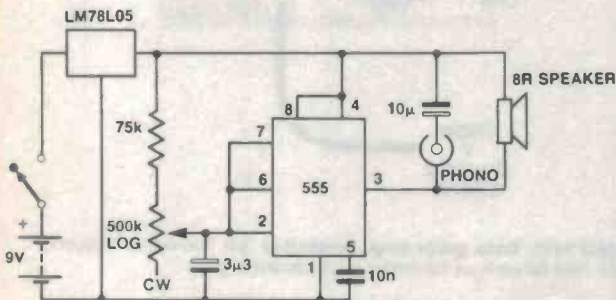

WOW! IT'S HERE

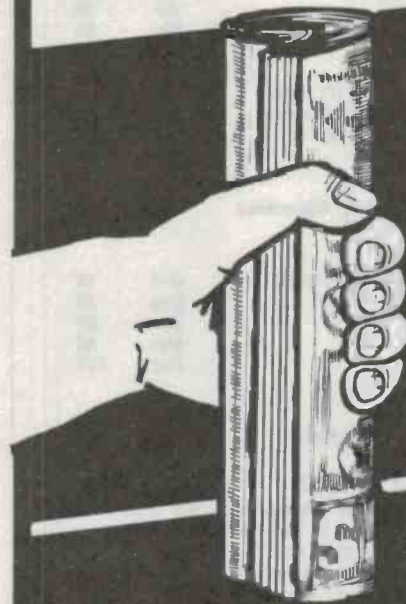

ASK FOR YOUR COPY TODAY

\$3.95

AN ELECTRONICS TODAY PUBLICATION

Circuits COOKBOOK #5

A BUMPER ISSUE PACKED WITH CIRCUITS AND IDEAS FOR THE ENGINEER TECHNICIAN & HOBBY ENTHUSIAST

COMPUTERS + AUDIO + RF ELECTRONIC MUSIC & MORE

ALSO AVAILABLE BY MAIL ORDER

\$3.95 plus \$1 postage

FEDERAL MARKETING

P.O. BOX 227

WATERLOO, N.S.W. 2017

ALLEN-BRADLEY 700 SIL RESISTOR NETWORKS

PRICE REDUCTION

Now even better value!!

We've closed the gap between the best in quality and competitive pricing.

That's the amazing difference between Allen-Bradley series 700 networks and look-alikes.

We've revolutionised the manufacture of networks - now our consistent quality makes Allen-Bradley the most dependable performance networks available at the price.

Select from a wide range of series 700 Standard circuits and popular ohmic values in 6, 8 or 10 pin packages, 50 resistance values from 22 ohms to 1 megohms.

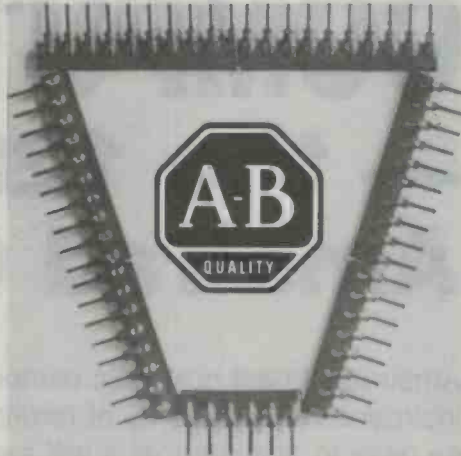

Top marked pin #1 indicator; speeds assembly and inspection even on densely packed boards.

True low-profile; 4.83mm maximum package height specification.

Legible laser marking top and side; permanent, easy to read, and resistant to board washing fluids.

For fast delivery contact your nearest Allen-Bradley office or distributor.

Allen-Bradley - 75 years of cost-effective, innovative electrical component manufacture.



ALLEN-BRADLEY
A Rockwell International Company

Design excellence and quality in the best tradition.

VIC. 37 Chapman Street, Blackburn, 3130. Ph. 899 0335
N.S.W. 22 Parramatta Road, Lidcombe, 2141. Ph. 648 2652
QLD. 1925 Logan Road, Upper Mt. Gravatt, 4122. Ph. 343 7900
W.A. P.O. Box 23, Subiaco, 6008. Ph. 387 1702
S.A. K. D. Fisher, P.O. Box 170, St. Marys 5042. Ph. 277 3288

ETI READER SERVICE 129

Ernest Turner instruments

VU AND PPM METERS

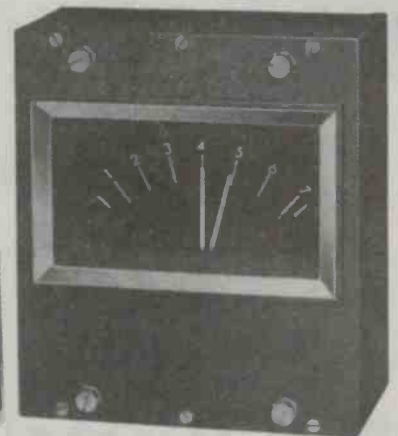
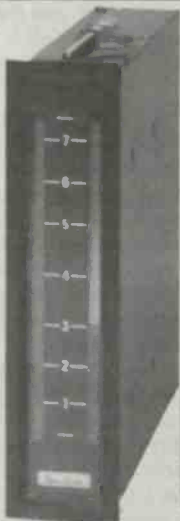

**"UNEQUALLED REPUTATION
FOR EXCELLENCE"**

HAWKER SIDDELEY COMPANY

Crompton Instruments

HEAD OFFICE: PO Box 492, Campbelltown 2560
Works - Airs Road, Minto NSW
Telephone: (02) 603 2066
Telex: 26074

MELBOURNE: 13/456 St Kilda Road,
Melbourne, Telephone: (03) 267 3299
Telex: AA34125

'WHAT CRS PORTABLE HAS 40 CHANNELS?'



...THE ANSWER IS IN THE PALM OF YOUR HAND

Now you don't have to leave your communications behind when you leave your vehicle. The ICOM IC-40 is a compact 40 channel UHF CRS field proven hand held, with optional 3 Watts output power, the same as many

mobile radios.

The IC-40 is perfect for jobs on the land, water or business.

Contact your local dealer for a demonstration of the most advanced CRS portable available in Australia.

Please post to:

ICOM AUSTRALIA PTY. LTD.
7 DUKE STREET WINDSOR 3182.
VICTORIA.

Name _____

Address _____

City _____ Postcode _____

or phone ICOM on (03)51 2284



ICOM

The World System

IC0013

COMPUTER REVIEW

HOME COMPUTER — the 128K Amstrad 6128

Amstrad's latest domestic computer is a little beauty. It's inexpensive, has plenty of terrific software applications, and is so easy to operate that it will appeal even to beginners. Not only that, its capabilities are so great that the very experienced user will be impressed too!

Jon Fairall

THE AMSTRAD COMPANY of Britain is well-known in Australia for the provision of a line of excellent domestic computers over the last few years. With the release here of its 128K computer, named the 6128, it has continued a tradition of cheap, easy-to-use machines.

The 6128 comes in the standard long, thin case familiar from previous Amstrads. Inside there is a Z80A processor with two banks of 64K RAM, plus ROM for the resident BASIC language and AMSDOS operating system. There is also a three inch disk drive located just to the right of the keyboard. Output ports around the back are for disk drives, printers and expansion modules.

The basic package of the 6128 includes a CP/M 2.2 disk with Logo from Digital Research and a big Help package to allow you to make some sense of CP/M. Cost for this, plus the CPU and greenscreen monitor, is only \$799. An RGB monitor is sold as an option. The package we reviewed was supplied with an Advanced Amword wordprocessor, a database called Masterfile and an Amsoft business package with stock control, sales invoicing and sales ledger programs on it.

Software-wise, CP/M plus 128K of RAM adds up to a huge range of applications programs ready made. It also means some ex-

citing programming challenges. The thing that interested me, however, was not the high end features, but the way Amstrad has designed the machine to appeal to the inexperienced user. After all, many machines on the market today do appeal to the serious user; there aren't many which can claim to get it right for the beginner as well.

BASIC

When you switch on the 6128, it comes up with BASIC alive, well and begging for action. The BASIC is a joy to use. It has all the usual commands and, I think, three features that deserve mention. Firstly, editing is incredibly simple. Lines can be retyped, edited using an EDIT command, or copied. The copy function requires that you use CONTROL plus an arrow to move the 'copy cursor' over the beginning of a line to be copied. Then pressing the COPY button will cause the main cursor to copy the line. Any alterations or additions to the line can be made by direct input from the keyboard. It's remarkably effective.

The only thing I don't like about Amsoft's BASIC is that it is sensitive to a space. So 10ForX=1to5 is not the same as 10 For X = 1 to 5 and will result in an error message. This is irritating, but no doubt regular users get accustomed to it soon enough.



Predictably, there is a powerful graphics and screen management facility in the BASIC. You can specify each pixel in 27 colours and to improve animation there is a command, FRAME, that synchronises the movement of characters on the screen to the scanning frequency of the display. For circular shapes there is an ORIGIN command which changes the position of the origin of the screen co-ordinates to the centre of a circle, and a FILL command, which colours in an enclosed area of the screen.

Graphics information is stored in 16K of the first bank of 64K of RAM. However, it is possible to specify up to five blocks of memory in the second bank. This means it is possible to specify up to six screens. Only the #0 screen is displayed however, so it is necessary to bring the others down using a SCREENSWAP command.

Incidentally, for the most part the second 64K bank needs to be accessed through a utility called Bank Manager. BASIC itself only addresses the first 64K.

Another part of the graphics capacity I liked was the windowing ability. Using the WINDOW command, it is possible to specify a screen window. The window is numbered (#0 to #6) and then a whole range of commands can be directed to that window. For instance the command 10 PRINT #4
" will send a text message to window

4. It's even possible to specify different colour combinations within the window for ease of display.

The sound facility is centred around the SOUND command. This has arguments that specify tone, duration, volume, envelopes and noise period. In addition, each of them can be set via a separate command. The envelope commands allow you to vary the volume or tone, set the number and size of steps and the time taken for each. In theory you ought to be able to recreate just about any sound imaginable.

DOS

The ROM residential disc operating system is called AMSDOS, and handles all the basics of loading, saving and running programs from the drive. It also provides a cassette interface, presumably to allow users with software for earlier Amstrad machines to upgrade easily.

It is entirely compatible with CP/M 2.2. The CP/M BIOS (basic input output system) is stored in ROM on board, but the rest of it comes in two disks. Both AMSDOS and CP/M use the same file structure and may read and write to each other's file. The manual gives lengthy hints on installing programs based on CP/M in the Amstrad, and assures the reader that few CP/M programs can't be made to work.

The market

Since its release in Australia late last year the 6128 has already sold 10,000 units according to John Chandler of Mitsubishi-AWA. This makes it one of the most popular 128K machines in the country. Clearly, Amstrad has a winner on its hands.

And the company deserves it. Amstrad has managed to combine a serious machine with something that can be used by a complete beginner. Consider, for instance, that wonder of wonders . . . it has a manual that explains far more than it confuses. The mysteries of BASIC and AMSDOS are clearly explained for those interested, while people who just want to run applications programs will find all the information they need as well. Clearly, the 6128 has benefitted from the years of experience Amstrad has had in tailoring its machines to the needs of schools and young people.

At the same time, one would need to be quite an advanced computer user before exhausting the capabilities of the 6128. I am always impressed with a machine that comes with a nice fat bus extending out the back. The spirit of Stephen Jobs and his Apple lives on.

Where to hear superb musical reproduction through concrete:

Victoria

Brashs - Blackburn
 Brashs - Geelong
 Brashs - Melbourne
 Brashs - Moorabbin
 Contemporary Sound Centre - Hawthorn
 Footscray Audio - Footscray
 John Martins Music Studio - Swan Hill
 Prouds Audio World - Bendigo
 Radio Parts - East Malvern
 Radio Parts - West Melbourne
 Sight & Sound - Ballarat

Tasmania

Hi-Fi House - Devonport
 Quantum Sound Centre - Hobart
 Wills Hi-Fi - Launceston

South Australia

ABS Computers - Moonta
 Blackwood Sound Centre - Blackwood
 Elliotts Sound Equipment - Mount Gambier
 WTR Sight & Sound - Whyalla

Western Australia

Alberts Hi-Fi - Fremantle
 Alberts Hi-Fi - Perth
 Alberts Hi-Fi - Victoria Park
 Esperance Electronics - Esperance

New South Wales

Apollo Hi-Fi - Marrickville
 Apollo Hi-Fi - Summer Hill
 Bankstown City Hi-Fi - Bankstown
 Haberechts World of Sound - Albury
 Hempel Sound - Roseville East
 High Street Hi-Fi - Maitland
 Hi-Fi House - Nowra
 Hi-Fi House - Wollongong
 Pitmans Audio - Wagga Wagga
 Selekt Sound - Bathurst
 Selekt Sound - Orange
 Sydney Hi-Fi Centre - Sydney
 Wardell Sight 'n' Sound - Newcastle
 Buckleys Music House - Grafton
 Byron Bay Sound Centre - Byron Bay
 Hall of Electronics - Port Macquarie
 Kempsey Hi-Fi & Video - Kempsey
 Lismore Hi-Fi - Lismore
 Sam Kee & Co - Inverell
 Sound Components - Armidale
 Sound Components - Tamworth

A.C.T.

Brashs - Phillip
 Kingston Hi-Fi - Kingston

Queensland

Action Replay Video - Mooloolaba
 City Hi-Fi & Video - Brisbane
 Custom Sound Centre - Nambour
 Gold Coast Hi-Fi & Video - Southport
 Handos Sound Dimensions - Brisbane
 Heilbron's Radio & TV - Monto
 Hunts Electronics & Hi-Fi - Ipswich
 Keller Electronics - Maryborough
 Noosa Hi-Fi - Noosa Junction
 Northside Hi-Fi - Aspley
 Toombul Music Centre - Toombul
 Hiway Sound Centre - Mount Isa
 Plaza Sight and Sound - Bowen
 Stereo World - Cairns

Northern Territory

Sound Spectrum - Darwin

Sole Australian Distributors:
SCAN AUDIO PTY. LTD.,
 52 Crown Street,
 Richmond, Victoria, 3121.
 Telephone (03) 429 2199.

SHOPAROUND

ETI-1402: Digital sampler

Now for a fraction of the cost of the commercial product musicians can build this excellent sampler. Both Jaycar and Geoff Wood will have the complete kit. Boards will be available from Rod Irving, All Electronic Components and RSC Radio.

ETI-172: Bit pattern detector

The ordinary hobbyist doesn't have a lot of tools at his/her disposal when it comes to figuring out the operation of a digital circuit. Multimeters will indicate the dc conditions and a logic probe will indicate the presence of signal. When that byte races by, this simple device will tell you what it is. The complete kit is being supported by Geoff Wood and pc boards will be available from Rod Irving, All Electronic Components and RCS Radio.

ETI-684 Intelligent modem

The parts list and construction will appear next month. The kit will be supported by Jaycar and Hi-Com.

Artwork

For those constructors willing and able to make their own pc boards and/or front panels, we can supply same-size film transparencies of the artwork, positives or negatives as you require. From the list given below, select what you want and address your request/order to:

'ETI-xxx Artwork'

ETI Magazine

PO Box 227,

Waterloo, NSW 2017

When ordering, make sure you specify positives or negatives, according to the process you use. Your cheque or money order should be payable to 'ETI Artwork Sales'. Prices for the artwork for this month's projects are as follows:

ETI-172 front panel \$6.45

pc board \$4.75

You might also care to know that almost every pc board (and most front panels) ever published by ETI may be obtained from:

All Electronic Components

118 Lonsdale St
 Melbourne, Vic 3000

RCS Radio

651 Forest Rd
 Bexley, NSW 2207

For pc boards produced in recent years, the following suppliers either keep stocks on hand or can supply to order:

Acetronics

112 Robertson Rd
 Bass Hill, NSW 2197
 (02) 645-1241

Bilco Electronics

Shop 2, 31 Pultney St
 Dandenong, Vic 2175

Jaetronics

58 Appian Drive
 St Albans, Vic 3021

Jaycar

117 York St
 Sydney, NSW 2000

Jemal Products

PO Box 168
 Victoria Park, WA 6100

Mini Tech

PO Box 9194
 Auckland, NZ

Rod Irving Electronics

425 High St
 Northcote, Vic 3070

Ian J. Truscott's

ELECTRONIC WORLD MORE & MORE

People are discovering us each week. Both the home enthusiast through to the small manufacturer.

★ ★ ★
 COMPONENTS ●
 TOOLS ● KITS

In any quantity, buy one, or one thousand, we're happy to oblige

SCHOOLS ● CLUBS
 ETC.

Inquire about our bulk discount deals

Save yourself a trip to the city - come to

30 LACEY STREET
 CROYDON

OR PHONE

(03) 723 3860/
 723 3094

Mail orders welcome.

ETI READER SERVICE 131

SHORTWAVE LISTENING

Shortwave radio provides an astonishing range of entertainment, news and information programmes, so it is hardly surprising that the popularity of shortwave listening throughout the world is constantly growing. As a special service to ETI readers our shortwave correspondent, Arthur Cushen, has compiled thorough listings of English-language programmes that can be heard in the Australian region. These broadcasts cover stations from nearly 40 countries. Whether you're an old hand at shortwave or a newcomer, you'll find the listings provide a valuable programme guide to keep you in tune. Happy listening!

POPULARITY OF SHORTWAVE

The tremendous increase in shortwave listeners is reflected in the number of receivers used throughout the world, which has risen from 235 million in 1955 to 1280 million in 1982. For many people, in urban areas of countries such as Australia and New Zealand, shortwave simply provides an interesting hobby. But for millions of other listeners elsewhere in the world, who do not have access to a good local radio service, it provides a daily supply of news and information.

The following comparison of shortwave receivers in use worldwide indicates the present popularity of shortwave and its growth over the last 30 years.

	Receivers in Use (millions)	
	1955	1982
Western Europe	65	273
Eastern Europe	20	131
Middle East & North Africa	2	44
Africa	1	40
Latin America & West Indies	13	116
Asia & the Far East	15	179
North America	116	477
Australasia	3	20
	235	1280

POPULAR ENTERTAINMENT PROGRAMMES ON SHORTWAVE

This programme listing covers music, educational sessions and a diversity of informative features, and is a summary of those best received in Australia. The listing is by UTC (GMT) time and the day is also a UTC day.

The frequencies given indicate the best reception during our winter period. There is a frequency change on 1 May, which has been taken into account so that station programmes featured are mainly for afternoon and evening listening in Australia (ie there is greater emphasis in the period between 0400 and 1200 UTC).

Time (UTC)	Day	Station & Country/City	Program	Frequency (kHz)
0009	Daily	BBC, London	News about Britain	9410, 9570, 11955
0010	Daily	Radio Moscow World Service, USSR	News and Views	9565, 9655, 12050
0010	Fri	Radio Australia, Melbourne	Along the Mighty Murray	15160, 15240, 17795
0030	Daily	Voice Of America (VOA), Washington DC	VOA Morning	15185, 15290, 17740
0030	Mon-Fri	Radio Australia	Music of RA	15160, 15240, 17795
0030	Sun	BBC, London	Baker's Half Dozen	9410, 9570, 11955
0030	Wed	Belgian Radio (BRT), Brussels	Stamps/QSLs	9925
0030	Tues	BBC, London	Sarah & Company	9410, 9915
0035	Mon-Fri	Radio New Zealand (RNZ) Wellington	Rural Report	15150, 17705
0045	Sat	BBC, London	Recording of the Week	9410, 9570, 11955
0100	Tues-Sat	BBC, London	Outlook	9410, 9915
0100	Mon	BBC, London	Matter For Debate	9410, 9915
0130	Sat	BBC, London	Classic Album	9915, 11955
0130	Thur	BBC, London	Waveguide	9410, 9915
0140	Sun	Radio Moscow	Your Top Tune	9655, 13605, 15170
0145	Sat	BBC, London	Letterbox	9410, 9915
0145	Fri	BBC, London	Book Choice	9410, 9915
0200	Daily	Voice of Free China (VOFC), Taipeh, Taiwan	News and Music	5985, 11740
0200	Daily	Radio Cairo, Egypt	Cairo Calling	9475, 9675
0210	Daily	Radio Moscow	Newsreel	9655, 11845, 15195
0230	Daily	Radio Pakistan, Karachi	Slow Speed News	15115
0230	Sat	Radio Australia	Desert Island Discs	15160, 15240, 17795
0240	Sat	Radio Moscow	Your Top Tune	9655, 11845, 15195
0300	Daily	Radio Prague, Czechoslovakia	Czech Today	9630, 9740, 11990

POPULAR ENTERTAINMENT PROGRAMS ON SHORTWAVE

Time (UTC)	Day	Station & Country/City	Program	Frequency (kHz)	Time (UTC)	Day	Station & Country/City
0300	Daily	Radio Budapest, Hungary	Features	9835, 11910, 12000	0750	Sun	BBC, London
0310	Daily	Radio Moscow	As We See It	9655, 11845, 15115	0800	Sat	KTWR, Agana, Guam
0310	Mon-Fri	VOA, Washington DC	Music USA Jazz	9650, 9740, 15205	0800	Mon	HCJB, Quito, Ecuador
0310	Mon	Radio Australia	Week in Science	15240, 17795	0800	Sat	Radio Finland (FBC), Helsinki
0310	Sat	Radio Australia	Talkback	15240, 17750, 17795	0800	Mon	Belgian Radio, Brussels
0315	Sun	BBC, London	From Our Own Correspondent	9410, 9915	0800	Sat	Belgian Radio, Brussels
0315	Mon	BBC, London	Good Books	9410, 9915	0810	Daily	Radio Moscow
0330	Sun	Radio Australia	Sports Magazine	15240, 15395, 17795	0810	Mon-Fri	Radio Australia
0330	Sat	Radio Dubai, UAE	Letterbox	9565, 11730, 15435	0815	Sat	BBC, London
0350	Daily	Italian Radio, Rome (Rome Radio)	Features	7235, 9575, 9710	0815	Sun	BBC, London
0400	Sun	Italian Radio, Rome (Rome Radio)	Italian Folklore	7235, 9575, 9710	0830	Sun	Swiss Radio
0400	Sun	Swiss Radio International (SRI), Berne, Switzerland	The Two Bobs	9725, 9885, 12035	0830	Sat	Swiss Radio
0400	Mon-Sat	Swiss Radio	Dateline	9725, 9885, 12035	0830	Mon-Sat	Swiss Radio
0400	Sun	Radio Sweden International (RSI), Stockholm	Nordic Report	9665, 9695	0830	Daily	Radio Austria
0400	Sat	Radio Sofia, Bulgaria	Music from Bulgaria	7115	0830	Mon	BBC, London
0405	Mon	Radio Canada International (RCI), Montreal	Shortwave Digest	9755	0830	Thur	BBC, London
0405	Sun	Radio Canada	Coast to Coast	9755	0900	Daily	FEBC, Manila, Philippines
0430	Daily	Radio Austria International (RAI), Vienna	Report from Austria	6000, 9580, 11660	0900	Mon-Fri	HCJB, Quito, Ecuador
0430	Tues	Voice Of Turkey (VOT), Ankara	Turkish Music	9560, 9730	0910	Daily	Radio Moscow
0440	Sun	Radio Moscow	Your Top Tune	9785, 11845, 15130	0910	Sun	Radio Japan (NHK), Tokyo
0440	Fri	Radio Australia	Letters to the Editor	15240, 17795	0910	Sat	Radio Japan
0440	Wed	BBC, London	Book Choice	5975, 9410, 9510	0915	Mon	BBC, London
0455	Daily	BBC, London	Reflections	9410, 9510	0930	Daily	Radio Finland
0500	Daily	Deutsche Welle, Cologne, West Germany	Features	5960, 6130, 9545	0930	Daily	Radio Beijing, China
0500	Mon	Radio Norway, Oslo	Norway This Week	9590, 11865	0930	Daily	Deutsche Welle, West Germany
0510	Daily	Radio Moscow	The Soviet Way of Life	9785, 12055, 15130	0940	Tues	Radio Finland
0510	Mon-Fri	Radio New Zealand	Roundabout	15150, 17705	0945	Thur	BBC, London
0516	Mon-Fri	Spanish Foreign Radio (REE), Madrid, Spain	Music	9630, 11880	1000	Mon-Sat	Swiss Radio
0530	Sat	Dubai, UAF	Letterbox	15435, 17775, 21700	1000	Sun	Radio Norway
0530	Mon	BBC, London	Letterbox	9410, 9510	1015	Sun	BBC, London
0530	Tues	BBC, London	New Ideas	9410, 9510	1030	Daily	Radio Beijing, China
0545	Sun	BBC, London	Letter from America	9410, 9510	1030	Sun	Radio Moscow
0600	Daily	VOFC, Taiwan	News and Music	5985, 11740	1030	Sat	Radio New Zealand
0605	Mon-Fri	Radio New Zealand	Checkpoint	15150, 17705	1030	Sun	Radio Nederland
0610	Daily	Radio Moscow	Newsreel	13705, 15130, 15500	1030	Fri	Radio Australia
0625	Mon-Fri	Radio New Zealand	Sports Report	15150, 17705	1030	Sun	Radio Australia
0630	Sun	BBC, London	Jazz for the Asking	9510, 9640, 11955	1030	Daily	Radio Budapest, Hungary
0630	Thur	BBC, London	Nature Notebook	9510, 9640, 11955	1030	Sat	BBC, London
0645	Daily	Radio Berlin International (RBI), East Germany	News and Music	17755, 21540	1046	Mon	All India Radio (AIR), Delhi
0709	Daily	BBC, London	Twenty-four Hours	9510, 9640, 11955	1050	Thur	Radio Nederland
0710	Daily	Radio Australia	International Report	15240, 15395	1050	Sat	Radio Nederland
0730	Wed	Radio Moscow	Listeners Request	13705, 15130, 15500	1100	Sat	Radio Sweden
0730	Thur, Sun	Radio Moscow	Folk Box	9450, 12055, 13705	1100	Sun	Sri Lanka Broadcasting Corporation (SLBC), Colombo
0730	Sun	Radio Nederland, Hilversum, Holland	Happy Station Music	9630, 9715	1110	Daily	Radio Moscow
0730	Tues	Radio Australia	Desert Island Discs	9580, 9655, 15240	1110	Mon-Fri	VOA, Washington DC
0730	Fri	Radio Australia	Business Horizons	9580, 9655, 15240	1115	Mon-Fri	Radio New Zealand
0730	Sat	Radio Sofia, Bulgaria	Music from Bulgaria	9700, 11720	1115	Wed	Radio Sweden
0730	Daily	Radio Prague, Czechoslovakia	Czech Today	11855, 17840, 21705	1115	Tues	BBC, London
0730	Daily	HCJB, Quito, Ecuador	Happiness Is	6130, 9745, 11925	1125	Daily	Radio Korea, Seoul
0730	Daily	Voice Of Malaysia (VOM), Kuala Lumpur	Malay Music	15295	1130	Sun	VOA, Washington DC
0730	Sun	BBC, London	From Our Own Correspondent	9510, 9640, 11955	1130	Mon-Fri	VOA, Washington DC
0730	Mon	BBC, London	Sarah & Company	9510, 9640, 11955	1130	Mon	Radio Australia
0745	Fri	BBC, London	Merchant Navy Programme	9510, 9640, 11955	1130	Sun	Radio Moscow
0750	Thur	Radio Nederland	Media Network	9630, 9715	1140	Daily	Radio Moscow
0750	Sat	Radio Nederland	Shortwave Feedback	9630, 9715	1210	Fri	Radio Australia
					1215	Wed	BBC, London
					1215	Thur	BBC, London
					1225	Wed	BBC, London
					1230	Mon-Sat	Radio Austria
					1240	Sat	Radio Moscow
					1309	Daily	BBC, London
					1310	Daily	Radio Australia
					1330	Fri	BBC, London
					1330	Mon-Sat	Swiss Radio
					1340	Mon-Fri	Radio Australia
					1340	Mon	Radio Moscow

Program	Frequency (kHz)	Time (UTC)	Day	Station & Country/City	Program	Frequency (kHz)
Waveguide	9510, 9640, 11955	1345	Sun	BBC, London	The Sandi Jones Request Show	11750, 15070
Distance Listening	15115				Norway This Week	7210, 9530, 15305
HCJB Hour	6130, 9745, 11925	1400	Sun	Radio Norway	The Concert Hall	6110, 9760, 11715
The Weekend Fare	11935	1415	Sun	VOA, Washington DC	Music USA Jazz	6110, 9760, 11715
Belgium Today	9880	1415	Mon-Sat	VOA, Washington DC	Listeners Request	5900, 7315, 9450
People in Sports	9880	1430	Wed	Radio Moscow	Folk Box	5900, 7315, 9450
The Way We See It	9450, 13705, 15130	1430	Thur, Sat	Radio Moscow	Happy Station Music	13770, 15560
Stock Exchange Report	9580, 15395	1430	Sun	Radio Nederland	Media Network	13770, 15560
Jolly Good Show	9510, 9640, 11955	1450	Thur	Radio Nederland	Radio Newsreel	11750, 15070
The Pleasure's Yours	9510, 9640, 11955	1500	Daily	BBC, London	A Jolly Good Show	11750, 15070
Grapevine	9560, 15305, 17830	1515	Tues	BBC, London	The Pleasure's Yours	11750, 15070
The Two Bobs	9560, 15305, 17830	1515	Thur	BBC, London	Mini Top Mits	7215, 9580
Dateline	9560, 15305, 17830	1530	Mon	Radio Australia	Australian Country Style	7215, 9580
Report from Austria	11840, 15410	1530	Wed	Radio Australia	Your Top Tune	6050, 7345, 9450
Anything Goes	9510, 11955, 15360	1540	Sat	Radio Moscow	Paris Calling Africa	6175, 11705, 17620
John Peel	9510, 11955, 15360	1605	Daily	Radio France		
Back to the Bible	11850, 15350			International (RFI), Paris		
Back to the Bible	6130, 9745, 11925	1610	Daily	Radio Moscow	Newsreel	5980, 7305, 9480
Newsreel	9785, 11830, 15460	1615	Fri	BBC, London	Science in Action	11750, 15070
Hello Australasia	11875	1615	Sat	BBC, London	Saturday Special	9410, 15070
DX Corner	11875	1615	Wed	BBC, London	Rock Salad	9410, 15070
Good Books	11750, 15070	1640	Daily	Radio Australia	Sports Results	7215, 9580
Northern Report	11935	1710	Sat-Sun	Radio Australia	International Report	7215, 9580
News and Music	9700, 11755, 15440	1710	Daily	Radio Moscow	The Way We See It	7315, 7345, 11770
News and Features	9505, 9715, 15275	1715	Wed	BBC, London	Monitor	9410, 15070
Music of Finland	11935	1715	Fri	BBC, London	Sarah & Company	9410, 15070
Monitor	11750, 15070	1740	Sun	Radio Moscow	Your Top Tune	7315, 7345, 11770
Dateline	9560, 15305, 17830	1745	Daily	BBC, London	Sports Round-up	9410, 15070
Norway This Week	9590, 15180, 17715	1830	Wed	Radio Moscow	Listeners Request	7305, 7345, 9830
Classical Record	11750, 15070, 17790	1830	Thur	Radio Moscow	Folk Box	7305, 7345, 9830
Review		1830	Daily	Radio Bangladesh, Dacca	Music	6240, 7490
Merchant Navy Programme	11750, 15070, 17790	1830	Wed	BBC, London	Top Twenty	7320, 9410
News and Music	9700, 11755, 15440	1830	Sat	BBC, London	Baker's Half Dozen	7320, 9410
Listeners Request	9785, 13705, 15135	1840	Mon	Radio Australia	Week In Science	7215, 9580
Saturday Scrapbook	6100, 9600	1900	Daily	Radio Afghanistan, Kabul	News and Music	5900, 6020, 11805
Happy Station Music	9650	1900	Sun	Radio Norway	Norway This Week	7215, 9525, 9590
Australians at Play	6040, 7215, 9580	1900	Sun-Thur	Radio New Zealand	Morning Report	11780, 15150
Matters of Faith	6040, 7215, 9580	1910	Daily	Radio Moscow	Newsreel	7305, 9515, 9865
Features	9835, 11910, 15160	1910	Sun	VOA, Washington DC	Sunday Report	6040, 9760, 11760
People and Politics	15070, 17790	1930	Sat	VOA, Washington DC	Press Conference USA	6040, 9760, 11760
Folk Songs	11795, 15130, 17875	2010	Daily	Radio Moscow	The Way We See It	7305, 7370, 9450
Media Network	9650	2030	Sun	Radio Nederland	Happy Station Music	9895
Shortwave Feedback	9650	2030	Thur	BBC, London	Business Matters	7320, 9410, 9570
Nordic Newsweek	15115	2030	Sat	BBC, London	Jazz for the Asking	7320, 9410, 9570
RMI Report	11835, 15120	2030	Sun	BBC, London	Sunday Half Hour	7320, 9410, 9570
The Way We See It	9450, 11900, 12055	2040	Sat	Radio Moscow	Your Top Tune	7305, 7370, 9450
Newsline	6110, 9760, 11715	2045	Daily	All India Radio	Features	9550, 9910, 11870
Nightcap	6100, 9600	2050	Sat	Radio Nederland	Shortwave Feedback	9895
Communications Magazine	15115	2100	Daily	Deutsche Welle, West Germany	Features	7130, 9765
Waveguide	11750, 15070	2110	Mon-Fri	Radio Australia	Stock Exchange Report	15240, 15395, 17795
Traditional Music	15575	2115	Daily	Radio Cairo, Egypt	Cairo Calling	9805
Issues in the News	6110, 9760, 15425	2115	Thur	BBC, London	Jolly Good Show	9570
Music USA	6110, 9760, 15425	2130	Wed	Radio Moscow	Listeners Requests	7280, 9450, 12040
Smiths Weekly	7215, 9580, 9770	2130	Thur	Radio Moscow	Folk Box	7280, 9450, 12040
Your Top Tune	9450, 11900, 12055	2130	Mon	Radio Australia	Sports Magazine	15240, 15395, 17795
Newsreel	7265, 9450, 11745	2130	Wed	Radio Australia	Books and Public	15240, 15395, 17795
South Asia Soundabout	9770, 7215, 9580	2135	Sat	Radio Canada	Shortwave Digest	11945, 15150, 15325
Nature Notebook	11750, 15070	2200	Sun	Radio Norway	Norway This Week	6015, 7215, 9525
Top Twenty	11750, 15070	2200	Daily	VOFC, Taiwan	News and Music	11740, 11805, 15370
The Farming World	11750, 15070	2200	Daily	Italian Radio, Rome (Rome Radio)	Features	5990, 9710, 11800
Report from Austria	11715, 15320	2205	Daily	Vatican Radio, Vatican City	Vatican News	6015, 9615, 11830
Your Top Tune	7265, 9450, 11745	2230	Tues	Radio Australia	Country Style	15160, 15240, 17795
Twenty-four Hours	11750, 15070	2230	Sat	BBC, London	New Ideas	9410, 9915
International Report	7215, 9580	2230	Mon	BBC, London	Sports International	9570, 15070
John Peel	11750, 15070	2310	Daily	Radio Moscow	Newsreel	15385, 15570
Dateline	9870, 9885, 11955	2315	Sat	BBC, London	Letterbox	9570, 9915
Window on Australia	7215, 9580	2315	Sun	BBC, London	Letter from America	9570, 9915
Your Top Tune	7300, 9755, 9875	2330	Wed	BBC, London	Top Twenty	9570, 9915
		2330	Thur	BBC, London	Nature Notebook	9570, 9915
		2340	Sun	Radio Australia	Travellers Tales	15160, 15240
		2340	Fri	Radio Australia	Music of RA	15160, 15240
		2340	Wed	Radio Australia	Youth Talk	15160, 15240, 15395

INTERNATIONAL NEWS AROUND THE CLOCK

One of the great advantages of shortwave radio is that you can listen to international news as it breaks, and direct from the country of origin. Shortwave provides news on the hour, every hour, and at many other times in between.

The BBC has long been regarded as the major international news source presenting information which is unbiased, fast and factual. However, there are several other excellent services and numerous others of some merit.

The summary of news broadcasts listed here covers programmes in English which are audible in Australia around the clock. The best frequencies have been chosen and these are valid up to September 1986. The times of the broadcasts (given in UTC) are stable in countries observing Daylight Time, when they are heard one hour earlier. To reduce repetition, stations such as the BBC, Radio Australia, VOA, AFRTS and others which have news on the hour every hour are shown only when frequencies change.

ABBREVIATIONS

ABC	Australian Broadcasting Corporation
AFRTS	US Armed Forces Radio and Television Service, Arlington, Virginia, USA
AIR	All India Radio
BBC	British Broadcasting Corporation World Service
BRT	Belgium Radio and Television Overseas Service (Belgian Radio)
DW	Deutsche Welle, Cologne, GFR (West Germany); also known as Voice of Germany
FBC	Finnish Broadcasting Company (Radio Finland)
FEBC	Far East Broadcasting Company, Manila, Philippines
HCJB	Voice Of The Andes, Quito, Ecuador
IBA	Israel Broadcasting Authority
NHK	Radio Japan
PNG NBC	National Broadcasting Commission, Papua New Guinea (National Radio)
RAI	Radio Austria International (Austrian Radio)
RBI	Radio Berlin International, GDR (East Germany)
RCI	Radio Canada International
REE	Radio Exterior de Espana (Spanish Foreign Radio)
RFI	Radio France International
RNZ	Radio New Zealand
RSI	Radio Sweden International
SIBC	Solomon Islands Broadcasting Corporation
SLBC	Sri Lanka Broadcasting Corporation
SRI	Swiss Radio International
VOA	Voice Of America, Washington DC, USA
VOFC	Voice Of Free China, Taiwan
VOG	Voice Of Greece
VOI	Voice Of Indonesia
VOM	Voice Of Malaysia
VON	Voice Of Nigeria
VOT	Voice Of Turkey
VOV	Voice Of Vietnam, Hanoi

Time (UTC)	Station & Country/City	Frequency (kHz)
0000	Radio Australia, Melbourne	15240, 15395, 17790
0000	BBC, London, UK	9410, 9915, 15070
0000	VOA, USA	15185, 15290, 17740
0030	BRT, Belgium	9925
0100	Radio Prague, Czechoslovakia	9540, 9630, 9740
0100	AIR, India	9595, 9912, 11740
0100	Radio Moscow, USSR	11810, 11845, 15170
0200	DW, West Germany	9615, 9690, 11945
0200	BBC, London, UK	9410, 11955, 15380
0200	Radio Bucharest, Romania	9510, 9570, 11940
0200	VOFC, Taiwan	9685, 11825, 15125
0230	Radio Nederland, Holland	9590, 9895
0300	Radio Australia, Melbourne	15240, 15395, 17790
0300	RCI, Canada	9755
0300	BBC, London, UK	9410, 9580, 11955
0300	Radio Polonia, Poland	9525, 11815
0330	Radio Tirana, Albania	7300
0330	Radio Dubai, UAE	9565, 11730, 15435
0340	VOG, Greece	7395, 9420
0345	RFI, France	9790, 9800, 11995
0350	Italian Radio, Rome (Rome Radio)	9770, 11905, 15330
0400	Radio Australia, Melbourne	15165, 15240, 17715
0400	BBC, London, UK	9410, 9915, 11955
0400	Radio Sweden, Stockholm	9665, 9695
0400	SRI, Switzerland	9725, 12035

Time (UTC)	Station & Country/City	Frequency (kHz)
0400	AFRTS, USA	11790
0400	VOA, USA	9670, 9770
0430	RAI, Austria	6000, 9635
0430	Radio Nederland, Holland	9895
0500	DW, West Germany	9690, 11705
0500	BBC, London, UK	6175, 9410, 9510
0500	IBA, Israel	9009, 9815, 11655
0500	VON, Nigeria	7255, 15185
0500	REE, Spain	9630
0500	Radio Moscow, USSR	9580, 11710, 11770
0530	Radio Dubai, UAE	15435, 17775, 21700
0530	Radio Kuwait, Kuwait	15345
0600	Radio Australia, Melbourne	15165, 15395, 17715
0600	BBC, London, UK	9410, 9915, 15360
0600	VOM, Malaysia	15295
0600	RNZ, New Zealand	15150, 17705
0600	Radio Moscow, USSR	9450, 9580, 9785
0615	RCI, Canada	9760, 11825, 11840
0630	Radio Polonia, Poland	9675
0645	Radio Bucharest, Romania	11940, 15250, 15335
0700	Radio Tirana, Albania	9500, 11985
0700	Radio Australia, Melbourne	15165, 15240
0700	AFRTS, USA	6030, 11790, 15400
0730	Radio Nederland, Holland	9630, 9715
0800	ABC, Australia	4920, 9660, 9680
0800	BRT, Belgium	9880, 15515
0800	RBI, East Germany	21540
0800	BBC, London, UK	9510, 15360
0800	VOI, Indonesia	11790
0800	VOM, Malaysia	15295
0800	Radio Pyongyang, North Korea	11830
0800	Radio Moscow, USSR	9450, 9785, 11735
0800	AFRTS, USA	9530, 9590, 15265
0800	Radio Vanuatu, Vanuatu	3945, 7260
0830	RAI, Austria	11840, 15410
0830	Radio Beijing, China	9700, 11755, 15440
0830	Radio Prague, Czechoslovakia	9505, 11990
0830	FEBC, Philippines	11890, 15350
0830	SRI, Switzerland	9560, 15305, 15570
0845	Radio Japan, Tokyo	11875
0900	ABC, Australia	6140, 6150, 9660
0900	Radio Australia, Melbourne	6060, 7215, 9580
0900	BBC, London, UK	9510, 11750, 15070
0900	PNG NBC, Papua New Guinea	4890
0900	AFRTS, USA	6030, 9530, 9590
0930	Radio Beijing, China	9700, 11755, 15440
0930	FBC, Finland	11935, 15265
0930	DW, West Germany	9715, 15185, 17780
0940	VOG, Greece	15630, 17565
1000	ABC, Australia	6140
1000	AIR, India	11795, 15130, 17870
1000	Radio Norway, Oslo (Sun)	15165, 15180, 17750
1000	SRI, Switzerland	9560, 15305, 15570
1000	AFRTS, USA	6030, 9530, 9590
1000	Radio Moscow, USSR	9785, 11830, 13665
1000	VOV, Vietnam	9840, 12035
1030	RAI, Austria	12025, 15270
1030	Radio Nederland, Holland	9650
1030	Radio Budapest, Hungary	9835, 15160, 15220
1030	SLBC, Sri Lanka	11835, 15120
1100	Radio Australia, Melbourne	6060, 7215
1100	BBC, London, UK	11750, 15070, 17790
1100	RNZ, New Zealand	9600, 11780
1100	Radio Pakistan, Karachi	15605, 17660
1100	Radio Korea, Seoul	7275, 15575
1100	RSI, Sweden	15115
1100	VOA, USA	6110, 9760, 15425
1100	Radio Moscow, USSR	9450, 9785, 15280
1200	RCI, Canada	9650, 11955
1200	Radio Kampuchea, Kampuchea	9695, 11940
1200	Ulan Bator Radio, Mongolia	9615, 12015
1200	Radio Damascus, Syria	15325
1200	VOA, USA	6110, 11715, 15425
1200	Radio Tashkent, USSR	5945, 9600, 9715
1230	Radio Bangladesh, Dacca	15525, 17645
1230	RBI, East Germany	15440, 17700, 21540
1300	Radio Australia, Melbourne	6080, 7205, 9580
1300	RCI, Canada	9650, 11955, 15440
1300	BBC, London, UK	11750, 15070, 21550

Time (UTC)	Station & Country/City	Frequency (kHz)
1300	Radio Norway, Oslo (Sun)	9590, 15305, 17740
1300	AFRTS, USA	15330, 15430
1300	VOA, USA	6110, 7230, 9760
1300	Radio Moscow, USSR	6020, 7305, 9450
1400	Radio Australia, Melbourne	6035, 6080, 7205
1400	Radio Beijing, China	9550, 11600, 15160
1400	Radio Korea, Seoul	9570, 9750, 15575
1400	SRI, Sweden	15345, 21570
1430	Radio Nederland, Holland	11735, 13770, 15560
1500	Radio Australia, Melbourne	6035, 6080, 7205
1500	DW, West Germany	7225, 9735, 15135
1500	Radio Japan, Tokyo	9505, 9575, 9605
1500	AFRTS, USA	15330, 15430
1500	Radio Moscow, USSR	9450, 9560, 11830
1510	Radio Vatican	6250, 7250, 9645
1600	BBC, London, UK	9410, 9750, 15070
1600	VOA, USA	9760, 11760, 15205
1605	RFI, France	6175, 11705, 15425
1630	Radio Nederland, Holland	6020, 15570
1700	Radio Australia, Melbourne	6060, 6080, 7205
1700	BBC, London, UK	5975, 6015, 9410
1700	SRI, Switzerland	3985, 6165, 9535
1800	BBC, London, UK	7325, 9410, 12095
1800	RNZ, New Zealand	11780, 15150
1800	VOA, USA	6040, 9760, 11760
1815	Radio Bangladesh, Dacca	6240, 7490
1830	Radio Yugoslavia, Belgrade	6100, 9620, 11735
1900	Radio Afghanistan, Kabul	7310
1900	Radio Australia, Melbourne	6060, 6080, 7215
1900	RCI, Canada	11945, 15325, 17875
1900	Radio Moscow, USSR	5980, 7320, 9600
2000	ABC, Australia	4920, 9660
2000	RCI, Canada	11945, 15325, 17820
2000	BBC, London, UK	7145, 9410, 9570
2000	IBA, Israel	7410, 9435, 11605
2000	Radio Norway, Oslo (Sun)	6015, 9610, 11850
2000	SIBC, Solomon Islands	5020, 9545
2000	Radio Yugoslavia, Belgrade	6100, 7240, 9620
2030	Radio Sofia, Bulgaria	6070, 7205, 9700
2030	Radio Nederland, Holland	9715, 9895, 11730
2030	Radio Portugal, Lisbon	7155, 9605
2100	Radio Australia, Melbourne	15160, 15240, 17795
2100	DW, West Germany	6185, 7130, 9765
2100	AIR, India	9550, 9910, 11870
2100	VOFC, Taiwan	9510, 9600, 11860
2115	Radio Cairo, Egypt	9805
2130	RCI, Canada	11945, 15325, 17820
2200	ABC, Australia	9610, 15425
2200	Radio Australia, Melbourne	15160, 15240, 17725
2200	BBC, London, UK	9410, 9570, 15070
2200	AIR, India	9665, 9910, 11620
2200	Italian Radio, Rome	5990, 9710, 11810
2200	VOT, Turkey	6105, 7215, 9730
2200	VOA, USA	11760, 15185, 17750
2200	Radio Moscow, USSR	9580, 9600, 11980
2205	Vatican Radio	6015, 9615, 11830
2300	Radio Australia, Melbourne	15160, 15240, 17725
2300	RCI, Canada	9755, 11710
2300	BBC, London, UK	9410, 9570, 12095
2300	AIR, India	7215, 11715, 11740
2300	Radio Japan, Tokyo	15195, 15235, 17755
2300	Radio Lithuania, Vilnius	9800, 13605, 15180
2300	RNZ, New Zealand	15150, 17705
2300	REE, Spain	9780
2300	VOA, USA	15185, 15290, 17740
2300	Radio Moscow, USSR	15155, 17730, 17850

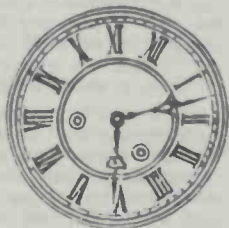

THE WORLD LISTENS

The enthusiastic shortwave listener listening to world news programmes is not alone in his or her quest. Newsrooms at radio and television stations, and in newspaper offices, have shortwave or satellite receivers handy so that when news breaks, it is possible to tune to the world's trouble spots.

After last year's earthquake in Mexico, I was telephoned by newspapers and people who had friends in Mexico City for information on when and where to listen for news direct from Mexico. However, due to the loss of power at most radio stations it was the radio amateur with his portable equipment who was able to provide the link to the outside world and send out news of the disaster.

Radio stations are a prime target in the case of a coup in which a government is challenged. In recent years an attempt to capture the army radio station in Bangkok in Thailand resulted in a 'shoot out' in which a well-known journalist was killed, and in Peru a rebel group recently held up a radio station and before leaving forced the staff to read a proclamation to the listening audience, thus informing the populace of their political aims.

International broadcasters have different views on the various international news stories, and monitoring stations are established by government agencies to listen to what competitors are saying. The BBC has an excellent programme called 'Monitor', which is a weekly survey and analysis of comment from radio stations around the world. The programme is carried in the BBC World Service and is heard on Wednesdays at 1715 UTC and repeated on Thursdays at 0145 and 0945.

Listeners would be well aware that Radio Australia, the BBC, VOA and other international stations make reference to 'Radio Moscow said ...' or 'All India Radio reported ...'; such information is gathered from monitoring broadcasts.

The so-called 'Moscow watchers' who listen to broadcasts from the Soviet Union do not turn to Radio Moscow World Service as that news service is geared for overseas listeners, but instead tune to the local stations which are intended for reception in the Soviet Union. As radio knows no boundaries, the alert monitor looking for political changes in leadership and happenings of a local nature is able to piece together what is happening inside the Soviet Union. Trained linguists translate these news bulletins into English and provide the BBC newsroom with information on major changes within Eastern Europe.



The enthusiastic shortwave listener.

SUMMARY OF MAJOR INTERNATIONAL NEWS PROGRAMMES

BBC, LONDON: The BBC has recently stepped up its news service to provide an hourly bulletin. Some of these broadcasts are only headlines, but at least news is available from London on the hour every hour.

The major news feature is 'News Desk' at 0400-0430 and 0600-0630 UTC. This session combines world news, reports from BBC correspondents, news from Britain, a selection of sporting news and press comment from British newspapers.

Australian listeners will find the other major news broadcasts at 2000, 2300, 0000, 0200, 0300, 0500, 0700, 0800, 0900 and 1100 UTC. Background to the news is covered in 'Twenty-four Hours', broadcast daily at 0509, 0709, 1309 and 2009 UTC. 'Radio Newsreel', news of events as they happen and despatches from BBC correspondents all over the world, is heard daily at 0015, 0215 (to South Asia), 1200 (except Sundays) and 1500 UTC. The 'World Today', which thoroughly examines one topical aspect of the international scene, goes out Mondays to Fridays at 1645 and 2209 UTC, and Tuesdays to Saturdays at 0315, 0545 and 0915 UTC.

The BBC newsroom at Bush House, London, is the nerve centre of the BBC news services. Here more than 250 news programmes are prepared every day for broadcast in the BBC's external services. The newsroom has an editorial staff of over 100 which is one of the largest in the world.

THE VOICE OF AMERICA: News originating from VOA studios in Washington DC is carried every hour on the hour in transmissions beamed to various areas of the world. For listeners in Australia the morning transmission at 2200-2400 UTC includes news at 2200 and 2300, and special English news at 2230 and 2330. The balance of the programme is 'VOA Morning' which includes reports from correspondents throughout the world in the period 2200-2230 and 2300-2330 UTC. The evening broadcast from 1100 UTC includes news, and 'Newsline' is broadcast Monday to Friday at 1130 followed by 'Music USA'. At 1200 UTC news is again broadcast followed by 'Focus', and at 1230 news features in 'special' English (which is English read at slow speed from a small vocabulary of words) are broadcast and are ideal for those wishing to learn English with the help of VOA news bulletins!

Another avenue of news from the United States is the Armed Forces Radio and Television Service (AFRTS) which operates a 24 hour a day schedule and, when not carrying sports, gives an excellent selection of the US network news bulletins. On the hour there is news from Associated Press followed each five minutes by United Press International, National Broadcasting Company, Colombia Broadcasting System, Mutual Broadcasting Company and on the half hour American Broadcasting Company. The transmissions received in this area are indicated in an hourly news summary.

RADIO AUSTRALIA: News is broadcast on the hour every hour for 10 minutes from the Melbourne studios. News from Australia is broadcast on the half hour, and there is a summary of major Australian news at 0130, 0430, 0830, 1230, 1630, 1830, 2030 and 2330 UTC. 'International

Report', an in-depth look at international issues, is presented Monday to Friday at 1810, 2010, 2210, 0010, 0210 and 1210 UTC.

RADIO NEDERLAND: This station broadcasts to Australia at 0730, 0825, 1030 and 1125 UTC and includes a news bulletin every day, Monday to Saturday, at the start of the transmission, followed by a current affairs programme called 'Newsline'. Broadcasts are also heard at 1430, 1630, 1830, 2030, 0130, 0230 and 0530 UTC.

USSR: Radio Moscow World Service has news in English on the hour every hour, and news headlines on the half hour. The station also presents 'News & Views' at 0310, 0610, 0910, 1310, 2010 and 2310 UTC. 'Radio Newsreel' with on-the-spot reports from correspondents around the world is heard on weekdays at 0510, 0810, 1110 and 2210 UTC. Radio Moscow World Service is broadcast to this area at 0000-1300 and 2000-2400 UTC.

NEW ZEALAND: Radio New Zealand International has four transmission periods every day and these are timed to broadcast the main news and current events programmes which are carried on the domestic service. Up to 2 March these included: 'Morning Report', Sunday to Thursday at 1800-1900 UTC; 'Midday and Rural Report', Sunday to Thursday at 2300-2400 UTC; 'News and Checkpoint', Monday to Friday at 0500-0530 UTC; and 'Midnight Report' at 1100 to 1115 UTC daily. Monday to Friday, after the news at 0900, there is a 20-minute feature programme on national and international events.



The production team for 'New Ideas', a weekly BBC programme which looks at new products on the British market. From left to right are co-presenter Maureen Galvin, producer Trish Williams and program secretary Diana Taylor.

BOOK REVIEW — Arthur Cushen

'World Radio and Television Handbook', 40th Edition, approx \$36 RRP, published by World Radio and Television Company, Sol-ljvej 44, DK-2650 Hvidovre, Denmark; 600 pages and a soft cover. Editor-in-Chief Jens Frost and Editor Andrew Sennitt. (A Billboard publication.)

It is 40 years since the first 'World Radio and Television Handbook' was published. The price was three shillings and sixpence, and I remember purchasing 10 copies for listening friends in New Zealand. The Handbook has grown from some 70 pages to over 600 pages and I have been involved with the compilation of all information from the South Pacific over those 40 years. It is therefore with a genuine feeling of appreciation that I look at the 'World Radio and Television Handbook', 40th edition, and realise what the many editions have done for the radio listeners of the world.

The Handbook, which is often called the 'Listeners Bible', is a directory of the world's radio and television stations. The 1986 edition is a more 'swept up', brighter publication than in the past but the basic type of information is the same.

Stations are listed in complete detail by country and continental grouping, and the information given includes the address, schedule, frequencies, power, languages, highlights, verification policy for reception reports, interval signal and much more. Then, for cross-reference, the back of the book contains a complete list in frequency order of all the world's mediumwave and shortwave stations. In recent years there have also been unbiased reviews of new communication and portable receivers on the world market, and in the 1986 edition Larry Magne reviews such receivers as the FRG-8800, Sony ICF 2010, and the NRD-525.

Design-wise the new edition uses a red banner to make countries stand out and there are more photos and more colour pages than previously.

A special supplement at the end of the book includes results of tests on receivers and many other interesting articles. There is also a list of news broadcasts in English, as well as reception forecasts for 1986 and a look at future radio receiver designs.

World maps show the location of international broadcasting stations. Details of the dif-

ferent television systems used throughout the world and lists of DX programmes and DX clubs are also given.

Looking back over the 40 years since the Handbook was first published — and having met both its founder, O. Lund Johansen, who had the dream that the publication would assist the radio listeners to be better informed on world broadcasting, and the present editor, Jens Frost, who has carried out and expanded these ideas — one is conscious of what the Handbook means as an everyday reference to radio listeners, communications engineers and anyone who wants to learn about the present state of world broadcasting. The Handbook is a tribute to the founder, the present editor and the many monitors, collaborators and radio station staff throughout the world who provide the background information on which the Handbook is based.

Readers will be pleasantly surprised at the tremendous amount of work done to make the 40th Edition such a memorable one. Copies are available from technical books stores throughout Australia, and in New Zealand, from myself, the sole agent, at 212 Earn St, Invercargill.

BEST PRICES IN AUSTRALIA

COMPUTERS - PERIPHERALS - SUPPLIES

JOIN OUR HOME-SHOP DISCOUNT CLUB NOW & GET A FREE GIFT WORTH OVER \$45.00



"YOUR MICRO SUPERMARKET"

MICROTEX 666

VIATEL

VIATEL OFFER

MODEMS UNDER \$195

SPECIAL BONUS OFFER — BEST VALUE MODEMS IN AUSTRALIA
V21/23 MODEMS FOR IBM PC & compatibles APPLE II, II+, IIe
COMMODORE C64, C128. ALL V21/23 MODELS UNDER \$195.

BONUS: Buy this month & get a FREE 5 1/4" Disk Container (holds up to 100).
Price includes modem, software, S/tax, BONUS OFFER, 3 mths warranty &
P/H. Priced low so you have enough money left to join the MICROTEX
666 & VIATEL REVOLUTION. ALSO CONTROL DATA 5 1/4" DISKS FOR
\$19.95 INC. TAX. Plus \$2 for P/H. Phone inquiries welcome 9-6 PM 7 days.
ASK ABOUT OUR HOME — SHOP DISCOUNT CLUB. All Credit cards
ACCEPTED via phone. Above Trademarks Belong To Owners.

Valrian Enterprises Pty. Ltd. Dept. F241-6
P.O. Box 82, Broadmeadow, NSW 2292
Tel: (049) 69 5341 Tlx: 28328
32 Broadmeadow Rd., Broadmeadow



ETI READER SERVICE 134

Be part of
Today!



When we analyse the recent past and project the immediate future, computers and communications technologies play a vital part, but we must avoid the tendency to look only to the hardware level. The fact that technologists have appropriated words like 'communications', 'information' and 'data' and given them electronic rather than social meanings, should not disguise the fact that in the final analysis, communications involves people and ideas, not electronic bit and bytes.

People and Ideas . . . that's the side of Australia's Communications Revolution we tell about in this informal look at today's world of computers and telecommunications.

At your Newsagent now!

Or simply send \$4.95 plus \$1.00 post and packing to —
Federal Marketing Book Sales, P.O. Box 227, Waterloo
2017 NSW.



TEST INSTRUMENT CENTRE

FOR YOUR LABORATORY — WORKSHOP — HAM RADIO SHACK — HOBBY — WE STOCK FAMOUS BRANDS:

• OSCILLOSCOPES • FREQ. COUNTERS • DIGITAL & ANALOG MULTIMETERS • LCR METERS • SWR & RF POWER METERS • PANEL METERS, etc.

KIKUSUI COS5020-20MHZ 2CH DUAL TRACE



Sensitivity: 5mV/div-5V/div;
1mV/div at x5 MAG.
Bandwidth: DC or 10Hz-20MHz.
Sweep Speed: 0.2 μS-5s/div.
Sweep Mode: AUTO, NOFM, SINGLE

Trigger Source: CH1, CH2, LINE, EXT.
X-Y Operation, CHOP and TV.
CRT: 6-inch rectangular.
Z-axis CH1 Output.



RADIO COMMUNICATION CENTRE

SCAN AUSTRALIA

WITH THE WORLD'S BEST SCANNING RECEIVER.

AR-2002

SCAN AUSTRALIA WITH THE BEST!

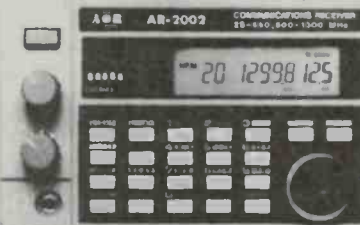

FEATURES: • 25-550MHz, 800-1300MHz
(UHF TV CHANNELS 550-800MHz EXCLUDED)
• NBFM-WBFM-AM MODES • 20 CH MEMORY
• CLOCK • PRIORITY CH • S-METER
• MANY OTHER FEATURES Send for colour brochure



NEW Personal 2-way radio here at last! "EMTRON ACE"

A QUALITY 40 CH HIGH POWER UHF CB HAND HELD TRANSCIVER
• DESIGNED FOR AUSTRALIA DOC APPROVED

FEATURES:

- 40 CHANNEL OPERATION
- HIGH (2.0W) LOW (0.5W) RF OUTPUT
- OFFSET FOR REPEATER OPERATION
- NICAD RECHARGEABLE BATTERIES
- ILLUMINATED DIAL FOR NIGHT OPERATION
- SMALL IN SIZE — BIG IN PERFORMANCE

APPLICATIONS:

- FARMING
- FISHING, BOATING, HUNTING, BUSHWALKING
- BUSH FIRE CONTROL
- AG SHOWS
- SECURITY
- CONSTRUCTION SITES
- CAR RALLIES
- CROWD CONTROL, AND MANY OTHERS

OPTIONS:

- 3W NICAD
- SP MME
- 1/2 WHP
- STAND-IN CHARGER
- DRY CELL PACK
- DCDC CONVERTER AND MANY MORE

DEALER INQUIRIES WELCOME



EMTRONICS

Retan Division of EMONA ELECTRONICS P L

NSW STORE & HEAD OFFICE:
92-94 Wentworth Ave, Sydney, NSW. 2000
Ph: (02) 211 0988. Telex: AA73990 (EMOLEC)
VIC STORE:
288-294 Queen St, Melbourne, Vic. 3000
Entrance from Little Lonsdale St.
Ph: (03) 67 8551 or 67 8181

Correspondence & Mail Orders: Box K21, Maymarket, NSW. 2000

ETI READER SERVICE 135

SMALLEST IS BEST

— the AR-2002 scanner from AOR

Peter Williams

For home or mobile use, the little AOR scanner shapes up very well. It's technically top of the class, and has several attractive features including wide frequency coverage, good sensitivity and a value-for-money price.



THEY SAY THAT small is beautiful, and after testing the AR-2002 scanner I'm inclined to paraphrase the famous saying to 'smallest is best'.

Since Jon Fairall's article on the general concept of scanners (December ETI), I haven't had the opportunity to check all the currently available units, however one would have to go a long way to beat, or even equal, the AR-2002.

Admittedly, not everyone has the same list of priorities when evaluating scanners. But there are some things that just **must** rate highly, such as sufficient frequency coverage/modes/channel steps, adequate sensitivity and absence (or presence) of 'birdies'. Then, depending on what you want your scanner to do you need to consider how many memories are available, the ease of operation and physical factors like ergonomics, size and if the unit is for home or mobile use.

In all respects I found the AR-2002 to be impressive.

Frequency coverage

The AR-2002 has the widest coverage of any of the units listed in December ETI (page 17). There is a gap between 550 and 800 MHz which should not worry anyone as this part of the UHF spectrum is devoted to UHF TV and other broadcasting links. I assume, of course, that scanner buffs are after more exciting communications and the loss of this particular segment will cause little concern.

On the other hand the coverage up to 1300 MHz is of somewhat academic interest as we don't have any regular services up there, with the exception of a few amateurs just below 1300 MHz. A few services probably operate in that area but the general availability of commercial two-way equipment means that you won't hear much. Of course, if general surveillance is your interest or your job, you can have the receiver scanning to see what comes up.

The coverage of 25-550 MHz/800-1300 MHz is completely adequate. One thing you should check on any scanner is the frequency increments that can be selected. With the AR-2002 you can select either 5, 12.5 or 25 kHz stops. This enables you to tune or program to the channel spacing used

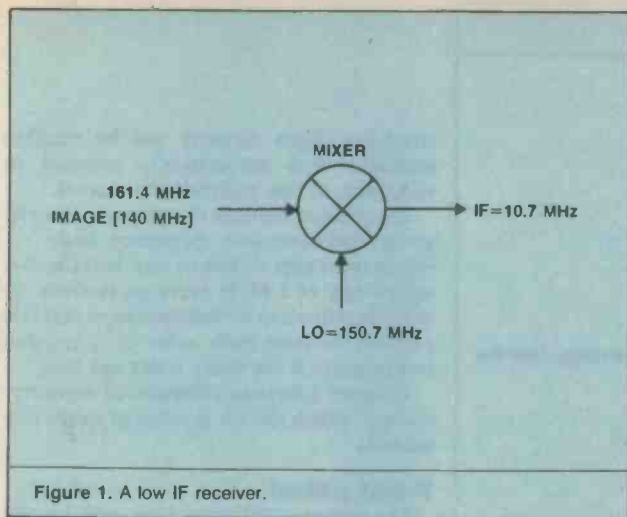

Figure 1. A low IF receiver.

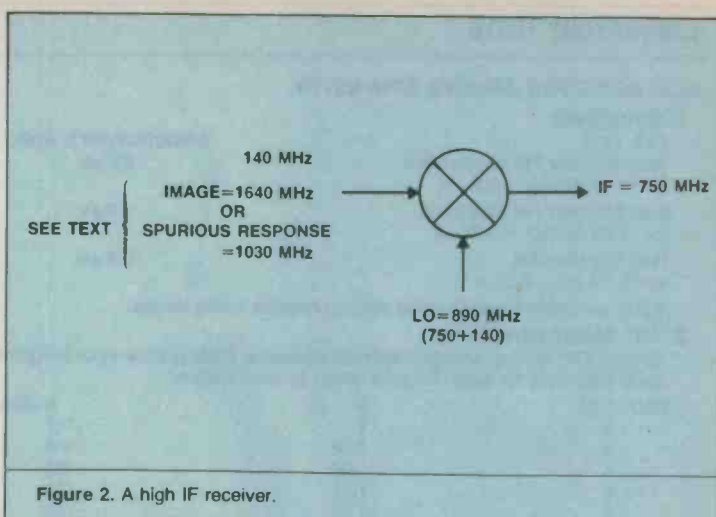

Figure 2. A high IF receiver.

in Australia, which is 30 kHz in the VHF bands (up to 174 MHz) and 25 kHz in UHF (above 400 MHz).

Some scanners made for the USA market used to have the selectable increments reversed (25 kHz for VHF and 30 kHz for UHF) which meant that in this country some frequencies could not be selected. Amateur operators using the 144 MHz band on VHF would be familiar with transceivers used for the USA market where the channel spacing was 15 kHz. As we use 25 kHz spacing, there is no way of making multiples coincide except at the 75 kHz points.

Since no such problem exists with the AR-2002, it is ideal for Australian conditions.

Sensitivity

Manufacturers' figures are usually correct, or almost correct! Sometimes the truth is hidden in an incomplete specification such as 'FM-1.0 μ V for 12 db SINAD'. Without specifying bandwidth or the frequency band in which the measurement was made, the figure quoted is almost meaningless and misleading.

AOR is not completely faultless in this respect for, although bandwidth is stated as narrow or wide, the band on which the figure is given is not stated. However, our lab tests fully vindicate the advertised figures and surprisingly gave a very good sensitivity figure at 1200 MHz.

One area that should always be explored with care is the response of a scanner to images. You know that you have an image if you can hear two stations on the same frequency and you know that one of them should be somewhere else!

A receiver with a high first IF frequency will give a very good image rejection figure.

The reason for images is illustrated in Figure 1. For example, take a receiver with a 10.7 MHz IF and suppose we want to listen to a signal on 161.4 MHz. You can see from Figure 1 that the local oscillator has to be 150.7 MHz to mix with 161.4 to give the 10.7 MHz IF. The 140 MHz frequency is obviously an unwanted signal, yet it can also

mix with the local oscillator to give the 10.7 MHz IF frequency. This signal at 140 MHz is called the image and is lower than the wanted signal by twice the IF frequency, ie, $161.4 - 21.4 = 140$ MHz.

Using a receiver with a low IF frequency such as 10.7 MHz you might receive amateurs on 144 MHz and some police VHF channels at the same time.

The AR-2002 has a good IF system. Its first IF is 750 MHz for VHF — an excellent choice because any image signal will be in a part of the spectrum where there is little activity.

Assuming you are listening at 140 MHz, any image would be coming from a signal at 1640 MHz if there was one about (see Figure 2). There is little chance of this happening as the tuned circuits would attenuate signals at this frequency (the receiver only tunes to 1300 MHz because of the band pass filter in the front end).

We did notice a strange effect when running our image response tests. With the receiver tuned to 140 MHz, we noticed a response at 1030 MHz. If you do the mathematics, you will see that 1030 MHz can mix with the 890 MHz local oscillator to give a frequency of 140 MHz (the frequency the receiver is tuned to). We can only assume that this 140 MHz signal is processed in the normal way through the receiver. Although derivations of both image frequencies would be heard for all selected input frequencies, we did not observe any problems when listening to the receiver.

With a low IF such as 10.7 MHz, tuned circuits find great difficulty in rejecting unwanted signals that are only 21.4 MHz away (twice 10.7 MHz).

On the 800-1300 MHz segment, the 750 MHz IF is bypassed and the output from the mixer is 45.03 MHz. This means that the image is 90.06 MHz away from the wanted signal. However, the scarcity of signals at this part of the spectrum means problems are unlikely.

Birdies

There is nothing more aggravating than to put a scanner to search and have it lock

up on a carrier which is generated internally.

The AR-2002 lab test panel lists eleven such 'birdies', which we also found. These frequencies are for the most part harmless, but annoying. If you put the receiver on to search it will lock up on each of the 'birdie' frequencies, but the effect can be eliminated if you turn up the squelch to quieten the receiver. Hopefully, a wanted signal will be stronger than the birdie so that it will be the only carrier to open the squelch. The worst strength birdie was 4 microvolts and the weakest was 0.28 microvolts, and they were on frequencies that do not matter.

Features/operating

The AR-2002 covers the two frequency ranges of 25-550 MHz and 800-1300 MHz, with the option of selecting channel increments of 5, 12.5 or 25 kHz.

Any mode of reception appropriate for the frequency range or channel spacing can be selected, except single sideband. Thus you can set up AM, FM wide or FM narrow.

FM wide is used for broadcast stations as it has a 100 kHz bandwidth. An SSB facility would be useful only for the CB band and part of the 144 MHz amateur band — perhaps the manufacturer was wise to leave it out!

The mechanical keyboard plus the front panel tuning control allows the receiver to be tuned up or down — conventional tuning via a knob is a real bonus for stepping up those channel increments, and eliminates a repunch of the keyboard if you make an entry error. I don't know of any other receiver of this type with a rotary tuner — it's good.

Control can also be exercised through the socket on the rear panel and, although I don't know of an AOR controller, the circuit indicates that a program from any computer using a modified RS232 would look after all the major functions if you wanted to operate remotely.

Memory channels total 20 and you can store frequency and mode without any re-

LABORATORY TESTS

AOR RECEIVER AR-2002 S/No 00170

1. Sensitivity

Lab Test

Freq 300 MHz FM narrow band
for 12 dB SINAD = 0.2 μ V

Freq 300 MHz FM wide band
for 12 dB SINAD = 0.79 μ V

Freq 300 MHz AM
for 10 dB s/n = 0.3 μ V

Manufacturer's Spec

0.3 μ V

1.0 μ V

0.5 μ V

NOTE: sensitivity basically same across complete tuning ranges.

2. "S" Meter sensitivity

Green LEDs light up as signal strength increases. Figures show input to light up the range. Note the small step sizes for each "S" point. Meter is always active!

LED	1 S	0 μ V	0 dBm
2	1		-107
3	1.12		-106
4	1.26		-105
5	1.41		-104
6	1.78		-102
7	2.24		-100
8	3.16		-97
9	6.3		-91
10	17.8		-82

3. MDS (minimum discernible signal) noise floor

Frequency 200 MHz narrow band FM
Result: 0.12 μ V or -125.5 dB

Frequency 1000 MHz narrow band FM
Result: 0.23 μ V or -119.9 dB

4. IF rejection

Low band: 200 MHz test frequency
55.2 dB IF rejection (750 MHz)

High band: 1000 MHz test frequency
38.6 dB IF rejection (45 MHz)

5. Image rejection

Low band: 140 MHz test frequency
Image will be at 1640 MHz
Spurious response noted at 1030 MHz (see text)
Rejection noted at -55.7 dB
Manufacturer's spec -50 dB

High band: 900 MHz test frequency
Image will be at 809.94 MHz
Rejection noted at -5.9 dB (see text)

6. Blocking dynamic range

Simply means that an interfering signal 20 kHz away from a weak, but wanted signal of -84 dBm has to have an equivalent signal level of -42.5 dBm to be just noticeable. Blocking dynamic range is 41.5 dB.

7. Internal spurious:

As listed in book, no others found.

Frequency MHz	Equiv signal level μ V
44.575	0.4
47.0	0.45
94.0	0.71
94.98	4.0
141.0	1.0
159.94	0.2
187.99	1.78
219.98	0.28
234.99	4.0
284.94	1.13
469.98	2.00

8. Squelch sensitivity

Frequency:	200 MHz	Frequency:	1000 MHz
FM wide:	0.7 μ V	FM wide:	1.0 μ V
FM narrow:	0.15 μ V	FM narrow:	0.21 μ V
AM:	0.11 μ V	AM:	0.13 μ V

9. Scan stop sensitivity

Frequency: 150 MHz; FM Narrow: sensitivity 0.24 μ V

10. Audio frequency response at 3 dB points ref 1 kHz

FM wide: 700 Hz — 13.5 kHz
FM narrow: 400 Hz — 1.4 kHz
AM: 265 Hz — 2.0 kHz

NOTES:

FM wide: there is 75 microsecond de-emphasis instead of the 50 microsecond used in Australia.
FM narrow: there is indication of de-emphasis in these response figures.
Minimum distortion: 2.2% NBFM 3 kHz deviation.

strictions. Each memory can be recalled manually and automatically scanned in sequence, at five channels per second.

In the usual manner of scanners, you can search between two frequency limits — either from high to low or vice versa with a search rate of 1 MHz every six seconds. A delay function can be switched in so that it is possible to hear both sides of a simplex transmission if the delay is not too long.

Channel 1 has been designated a priority channel which can be monitored every two seconds.

Front panel

The front panel is attractive, with no distracting impedimenta. Its small size and angled projection make it easy to see and operate.

Many scanners have vertical panels which make them difficult to read and adjust, especially when mobile.

Although the keyboard keys have double function, there is no shift key. The double function is automatic, with a micro inside figuring out which function you have selected.

The LCD display shows the frequency selected, mode, bandwidth, channel step and delay if scanning. A separate key changes the whole display into a crystal controlled real time clock.

The LED 'S' meter just to the left of the display is a useful addition to the front panel (our tests show inputs for various 'S' strengths).

Back panel

Back panel controls are limited. Apart from the remote control plug there is an oscilloscope-type BNC coaxial socket for antennas, a welcome improvement over the usual PL259 VHF socket. Even the old RCA audio plugs and jacks are better and more efficient than the old PL259 which must be celebrating a 50th birthday! Billed as a VHF/UHF plug up to 200 MHz, this latter has now outlived its usefulness. BNC sockets are the way to go!

For normal listening around the city, the telescopic antenna provided is adequate but a discone, or similar, would be more suitable if you plan to plumb the depths of VHF/UHF.

Technical

We were impressed with the schematic supplied by Emtronics, which showed that performance was no accident. The front end of the receiver is simple, but only made possible by the latest technology such as ECL chips in the rf amplifier.

The excellent performance of a receiver of this type is determined by the front end design (see Figure 3). What happens in the IF/detector department is fairly standard, and has less to do with performance than do the amplifier and conversion stages.

The high pass filter leads the signal to IC9, which is an 800-1300 MHz rf amplifier chip. For low band the chip is IC1 and covers from 25-550 MHz.

First mixing is done at D30, a balanced mixer with local oscillator running from 754.97 to 1300 MHz, controlled of course from the PLL.

The PLL is well designed using the latest technology in the form of ICs for VCOs. IC1 oscillates between 387.5 and 490 MHz and IC2 between 490 and 650 MHz.

The almost complete lack of discrete components in critical areas has, coincidentally, made the designer's task easier and performance much better. The first IF for the 25-500 MHz band, 750 MHz, removes images outside the tuning range of the receiver.

On the 800-1300 MHz hi-band, the first IF is bypassed and an IF is generated at 45.03 MHz. Certainly, image problems can arise but there are not too many signals 90 MHz away at hi-band — in fact, there are not too many signals of any kind to cause worry.

We were impressed with the actual on air performance of the front end because untuned and non-selective circuits as used in the AR-2002 usually accentuate any image problem, and many lead to cross modulation and over-loading effects. All we can say is that those ECL rf amps must be very linear, and the input filters contribute little in the way of deleterious effects. With the exception of the actual images mentioned earlier and as measured under laboratory conditions, performance was very good.

On air

Operation of all controls is smooth and the large, easy-to-read LCD display is particularly pleasing, being readable in daylight.

The dial up knob (tuning control) is sensible, with click/detente action giving easy control of the incremental stops of 5, 12.5 or 25 kHz as selected.

The 'S' meter (illuminated LEDs) was useful, as was the LCD display which relayed information on control settings.

Probably the keyboard deserves special mention as it is 'professional'. None of this membrane stuff. It gives a suitable tactile feedback to tell you that a positive action has been initiated.

All received signals were of excellent quality and the external speaker outlet enabled best use to be made of broadcast transmissions. Without the use of an external antenna, at least in the Melbourne area, FM stations were noise-free. The December ETI article on scanners made mention of antennas and I recommend a re-read of this with particular attention to the discone if you want a general coverage, VHF/UHF omni-directional antenna.

Overall

The AOR AR-2002 seems to be one of the best units in its class and price range. It is a 'no nonsense', rugged unit well suited for inconspicuous home or mobile use.

Technically, it is also top of the class (the schematic says 1985) and you can be assured of up-to-date technology.

I like the solid plastic case which is well finished and has a very functional, well laid out control panel.

Internally the pcb's are fibreglass and well laid out with ease of access for repair. It is worth mentioning that some of the ICs with NIS numbers are proprietary to AOR and, although commercial equivalents exist, there may be a little difficulty finding them. I would expect authorised dealers to have exact replacements, though.

It seems there has been little to criticise.

Maybe there are one or two technical points to question but they arise from laboratory observations, and certainly nothing technical would upset the utility and function of this receiver in the home or car.

With a size of 138 x 80 x 200 mm and weight of 1.5 kg, the AR-2002 can hardly be classified as huge and heavy.

I like the gear from this relatively small Japanese manufacturer, which has made other innovative designs in recent years (the first synthesised handheld transceiver, if I recall correctly).

I would say that this new receiver, at \$650 RRP, is excellent value for money.

Test receiver supplied by Emtronics.

Peter Williams is Director of Associated Calibration Laboratories, East Doncaster, Vic.

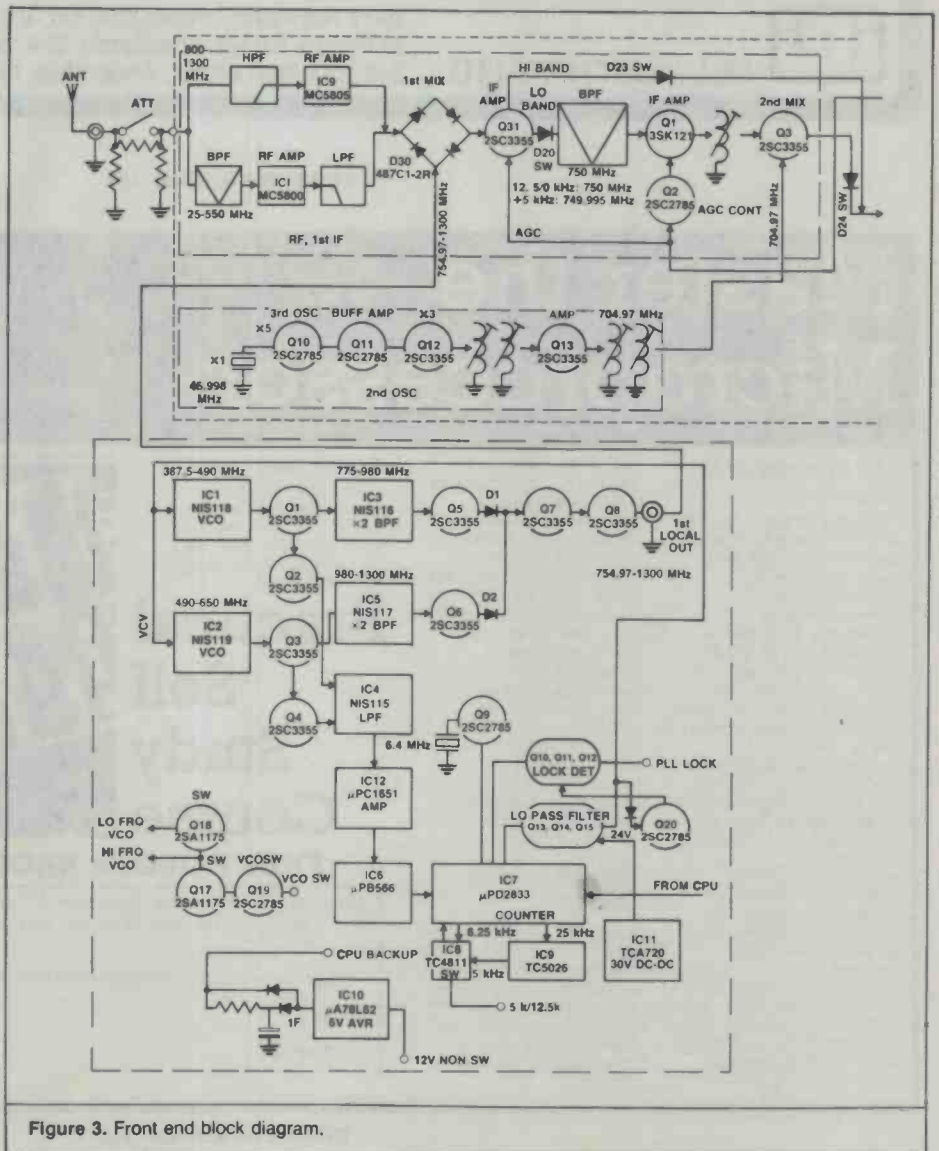
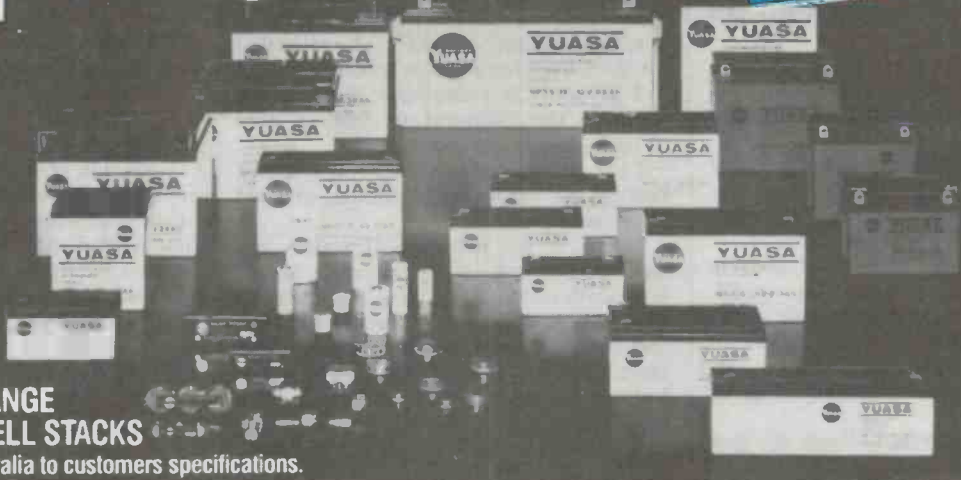

Figure 3. Front end block diagram.



Sealed lead acid & nickel cadmium rechargeable batteries

MAINTENANCE FREE



COMPLETE RANGE OF BUTTON CELL STACKS
assembled in Australia to customers specifications.



I.E.I. (AUST.) PTY. LTD.

15-17 Normanby Road, Clayton, Vic. 3149 Phone (03) 544 8411
31 Phillips Street, Thebarton, S.A. 5031 Phone (08) 352 2066
248 Johnston Street, Annandale, N.S.W. 2038 Phone (02) 692 0999

ETI READER SERVICE 133

Master the Microprocessor

Learn how Microprocessors really work
... the practical way.

The Purpose of this Course

There is a considerable, expanding and world-wide demand for people with a real knowledge of microprocessors and general computer technology. Such people are needed to design and evaluate systems and to assess and develop the enormous range of possible applications, both present and future, of microprocessors and to understand the installation and servicing of the main types of equipment of which they may form the most vital component (A microcomputer has already been produced to replace the mechanical programmer on a domestic washing machine, for example.) This Course provides the necessary basic information to enable a student to really understand the functioning of microprocessors and their supporting circuitry,

usually referred to as the "hardware". This is backed up by showing how to program a microcomputer (or produce its "software") in the most fundamental form of computer language called "machine code". No previous knowledge of computers is necessary, though a little basic knowledge of electronics plus digital and logic circuits will be found helpful. A special introductory short course is available to provide this background information if required by an individual student on the course without extra fee.

Student—Tutor Contact

A qualified Tutor is available to every Student throughout this Course in order to deal with any queries which may arise and to assess certain questionnaires which are issued in Students throughout the period of training.

Certificate

Issued to all Students completing the Course successfully. Course covers main requirements of the City and Guilds Certificates in Computers.

Practical Self Study Course

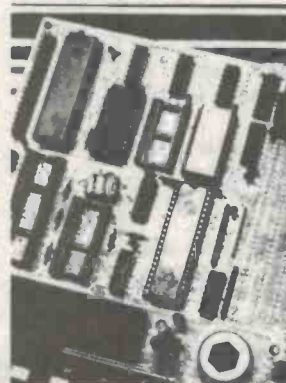

FREE COLOUR BROCHURE

Post coupon now The Australian School of Electronics Pty Ltd, P O Box 108, Glen Iris, Victoria, 3146

Please send your brochure without any obligation to

Name

Address

Postcode

How the Course is organised

The basis for the practical work in the Course is the Microcomputer. This is supplied completely assembled and ready to use. The Course text is carefully arranged in sequence so that each new section follows logically from previous work. Hardware description and programming technique progress together, so that the Student is discouraged from treating them as distinctly separate subjects. Following each section of descriptive text, detailed instructions are given in order to use the Microcomputer to provide a practical demonstration of each new function or technique. This provides a very powerful way of learning precisely how the system operates, and enables any possible ambiguities in the Student's mind to be quickly resolved.

ETI READER SERVICE 110

BOOKS OF SPECIAL INTEREST . . .

electronics textbooks

ELEMENTS OF ELECTRONICS- BOOK 1

This five book series is an introduction to modern electronics. All of the necessary mathematics is introduced and explained as required. The emphasis is on understanding concepts rather than digressing over the whole field. The author anticipates difficulties the beginner may have and explains them as they occur. BOOK 1 covers all of the fundamental theory necessary to understand simple electronic circuits and components. 209pp.
A0003B \$9.95

ELEMENTS OF ELECTRONICS- BOOK 2

See Book 1: Covers alternating current theory. 216pp.
A0004B \$9.95

ELEMENTS OF ELECTRONICS- BOOK 3

See Book 1: Covers semiconductor technology and introduces transistors and ICs. 204pp.
A0005B \$9.95

LINEAR IC EQUIVALENTS AND PIN CONNECTIONS

This invaluable addition to any electronic enthusiasts' library shows the equivalents and pin connections as well as the country of origin, manufacture and functions of a user-oriented selection of linear integrated circuits. The selection has been based on usefulness and practicality to designers, hobbyists and service engineers. 247pp.
B0006B \$12.95

PRACTICAL ELECTRONIC CALCULATIONS AND FORMULAE

For the practical person's workbench. Bridges the gap between practical theory and cut-and-dried methods which work but leave the experimenter unfulfilled. There's a strong practical bias and higher maths are avoided where possible. 249pp.
B0027B \$9.95

INTERNATIONAL DIODE EQUIVALENTS GUIDE

Includes zener diodes, LEDs, diacs, triacs, thyristors, OCIs; photo, display, and simple rectifier diodes. 130pp.
B0339B \$6.95

COIL DESIGN AND CONSTRUCTION MANUAL

How to make RF, IF, audio and power coils, chokes and transformers. Covers Am and FM radio and TV. An essential addition to the library of anyone interested in electronics. 106pp.
B0413B Now Reprinted! \$7.95

constructional projects

BEGINNER'S GUIDE TO ELECTRONIC PROJECTS

This guide enables the complete beginner to tackle the practical side of electronics so that the projects featured regularly in popular magazines can be approached with confidence. The basics are covered in detail using practical examples in the form of simple projects. 107pp.
C0030B \$6.95

RADIO CONTROL FOR BEGINNERS

Newcomers to the fascinating hobby of radio control will find this practical introduction invaluable. A number of constructional projects, many with complete board layouts, are included to help the beginner simply and successfully build up the circuits. 92pp.
C0034B \$6.95

SOLID STATE SHORTWAVE RECEIVERS FOR BEGINNERS

Details the design and construction of several solid state shortwave receivers giving a high level of performance yet utilising few components. 93pp.
C0044B \$5.95

REMOTE CONTROL PROJECTS

Primarily for the enthusiast who wishes to experiment with remote control. Full explanations of the how the circuits work are given and many of the designs can be adapted to circuits that have been published elsewhere. Covers remote control by ultra-sound and infra-red as well as radio control. 164pp.
D0046B \$7.95

ELECTRONIC SECURITY DEVICES

Besides including both simple and sophisticated burglar alarm circuits using light, infra-red and ultra-sonics, this book also gives circuits for gas and smoke detectors, flood alarms, fire alarms, doorphones, etc. 102pp.
D0059B \$6.95

HOW TO DESIGN ELECTRONIC PROJECTS

Tackles the problem of combining and integrating components into a complete working project with the minimum of trial and error and without advanced mathematics. Guides the reader through examples with circuit analysis, possible solutions and practical designs including component values. 101pp.
E0082B \$7.95

Postage and packing additional:
Please refer to reply card for charges.

test equipment and fault finding

HOW TO GET YOUR ELECTRONIC PROJECTS WORKING

Helps you to overcome the problem of a circuit that doesn't work after assembly by indicating how and where to start looking. Covers most of the common faults that occur when constructing an electronic project. 81pp.
F0114B \$7.95

TROUBLESHOOTING WITH THE OSCILLOSCOPE

Excellent for the professional service technician or serious hobbyist. It combines step by step procedures for using the 'scope with the specific nuts and bolts of television receiver troubleshooting. 92pp.
F0121P \$28.95

USE OF THE DUAL-TRACE OSCILLOSCOPE

This programmed text breaks down the process of operating a 'scope into a series of logical steps. It starts with the deflection of the electron beam and continues through the proper use of the triggering controls to measure the phase difference between two waveforms. 246pp.
F0259H \$43.50

electronic music and audio/video

ELECTRONIC MUSIC PROJECTS

Provides constructors with practical circuits for the less complex music equipment including fuzz box, waa-waa pedal, sustain unit, reverb and phaser, tremolo generator, and the like. Text covers guitar effects, general effects, sound generators, and accessories. 106pp.
G0135B Now Reprinted! \$7.95

AUDIO AMPLIFIER CONSTRUCTION

Provides a wide range of preamplifier and power amplifier designs including a low noise microphone, tape head and guitar preamps, and various tone controls. Written for those with limited experience in construction, but certainly useful for the more advanced hobbyist. 99pp.
G0132B \$7.95

AUDIO

A theoretical study of sound waves and acoustical quantities which leads into a study of hearing and room acoustics. A discussion of microphones and loudspeakers is developed into sections on amplifiers and recordings, covers digital as well as magnetic and disc recording. 308pp.
G0332B \$8.95

computer hardware and techniques

THE USER'S GUIDE TO COMMODORE 64 & VIC 20

The editors of Consumer Guide have compiled a thorough introduction to the Commodore 64 and Vic 20 computers, software and peripherals. With colour illustrations and a clearly written text, this reference will guide the newcomer through all phases of learning how to use the computer: From setting the system up, learning what each key does, expanding the system with peripherals, to buying new software. Specific exercises are included for each of the keys. Spiral bound, 80pp.
H0065G \$8.50

INTRODUCING THE APPLE IIc

This introduction to the remarkable features of the Apple IIc is also an excellent resource manual: Each chapter starts with elementary explanations, moves on to more technical descriptions and ends with detailed references. The thorough text is supplemented by exhaustive appendices and a full glossary. 400pp.
J0084P \$27.95

EASY-TO-UNDERSTAND GUIDE TO HOME COMPUTERS

Confused by all those computer terms? This clearly written book from the editors of Consumer Guide tells exactly what computers are, how they work and why they are so amazingly useful, all in plain English. Here is all of the information needed to understand and use computers, and even to start programming. A special buying section compares the most popular home computers. This book is your ticket to the computer age! Spiral bound, 96pp.
H0066G \$8.50

COMPUTER TERMINOLOGY EXPLAINED

Concise explains the most common terms encountered by the home computer enthusiast as well as many of those used with mini- and mainframe computers. Includes tables of ASCII codes and BASIC control codes. 81pp.
H0143B \$5.95

SPOTLIGHT ON COMPUTER AWARENESS

An introduction to speaking confidently about how computers work, their applications, their history (from abacus to IBM) and employment prospects in computer related fields. Includes a comprehensive glossary. 84pp.
H0145P \$6.95

A PRACTICAL INTRODUCTION TO MICROPROCESSORS

Takes the reader through the construction of a simple microprocessor and experimenting with it to gain an insight into the complexities of microprocessing. The book assumes a general knowledge of electronics. 90pp.
J0158B \$5.95

ORDER TODAY —

Simply return the Freepost Reply Card!

MORE BOOKS OF INTEREST . . .

computer hardware and techniques

AN INTRODUCTION TO Z80 MACHINE CODE

Starts with a general background to microprocessing and then details the full set of Z80/Z80A Instructions. Also covers the use of address modes and gives machine specific listings and sample programs. 107pp. K0180B \$7.55

FORTH PROGRAMMING

Describes both FORTH-79 and fig-FORTH and shows how to write software using these languages and how to add new operations (words) and manipulate the stack. Includes more than 50 useful programs. 246pp. K0298P \$29.95

ALMOST EVERYBODY'S PERSONAL COMPUTER BOOK

Written for the computing beginner to break the enormous barrier of jargon and mystique that seems to surround computers. With a highly readable approach, the author introduces the basic concepts and develops them into a general discussion on personal computers including choosing and caring for a PC. Also offers an introduction to BASIC programming. 160pp. H0144Z \$8.95

MICROCOMPUTING DESIGN & TROUBLESHOOTING

Explains designing microcomputer systems and making them work without expensive commercial development systems or the need for costly test instrumentation. Includes a complete description of two microprocessors- the 8085 and the 6502. 346pp. J0161P \$26.75

Stock of some titles may be limited.

EASY ADD-ON PROJECTS FOR COMMODORE 64, VIC-20, BBC MICRO & ACORN ELECTRON

The simple and inexpensive projects include a pulse detector, model controller, light pen, lap sensor and more plus six projects that make up a weather station. 191pp. J0165B \$6.95

A Z80 WORKSHOP MANUAL

Intended for those who want to progress beyond programming in BASIC to topics such as machine code and assembly language programming or who need hardware details of the Z80-based computers. 184pp. J0283B \$8.95

SECRETS OF THE COMMODORE 64

A beginner's guide to the C64 with masses of useful information and programming tips as well as describing how to get the best from the powerful sound and graphics facilities. Includes two useful chapters on machine code. 109pp. J0297B \$5.95

MICRO INTERFACING CIRCUITS: BOOK 1

Guides those who are unaccustomed to microprocessor techniques but have some knowledge of electronics, through a practical approach to address decoding, parallel and serial interfacing, analogue to digital and digital to analogue converters, etc. 96pp. J0325B \$6.55

MICRO INTERFACING CIRCUITS: BOOK 2

Develops the practical side of interfacing introduced in Book 1. Discusses sound and speech generators, temperature and optical sensors, motor controllers, etc. 87pp. J0326B \$6.55

WILDCARDS 4

No tips, techniques or theory in this volume: It's mainly quality games with PCG graphics- games of strategy and games of fast reflexes, many of them taking full advantage of colour graphics. From simple Boxes (not so simple!) to Radio with complex scenery: This is a book that teaches the fun way. 109pp. K0024P \$15.95

AN INTRODUCTION TO MSX BASIC

For those wanting to learn to program, Microsoft Extended (MSX) Basic offers a powerful and flexible version of the most popular computing language. This comprehensive Introduction starts with the basics and progresses by stages to the more advanced programming techniques and includes coverage of advanced multicolour, sprite graphics, and the programmable sound generator. 88pp. K0047B \$6.95

Prices subject to change without notice.

INSTANT PROGRAMMING ON YOUR SEGA SC3000 COMPUTER

Spiral-bound for easy use, this is THE Sega SC3000 beginner's book! In carefully explained, easy to follow steps, it covers the function of each key and all of the commands needed for super fast mastery of BASIC programming. This is a book for do-ers: The second part of the book teaches the real art of programming with plenty of examples and subroutines. 84pp. K0051P \$12.95

THE BEST VIC/COMMODORE SOFTWARE

Trying to find the most suitable software for personal computers can be frustrating. The editors of Consumer Guide have compiled comprehensive reviews of VIC 20 and Commodore 64 programs based on ratings by user groups; further evaluation is given by the editors and Commodore software experts Jim and Ellen Strasma. Each review describes the program's purpose and features, detailing both the good points and bad. Each program has been rated for ease of use, clarity of written and on-screen instructions, and overall performance. The program's price, publisher, format and hardware requirements are also included. The reviews are presented in sets by topic: Word Processing, Business, Home, Education, Networking, Strategy Games, Arcade Games and Programming Aids. Spiral bound, 192pp. K0052G \$8.50

THE BEST APPLE SOFTWARE

Trying to find the most suitable software for personal computers can be frustrating. The editors of Consumer Guide have compiled comprehensive reviews of Apple II, II Plus and IIe programs based on ratings by user groups; further evaluation is given by the editors and Apple software expert Roe Adams. Each review describes the program's purpose and features, detailing both the good points and bad. Each program has been rated for ease of use, clarity of written and on-screen instructions, and overall performance. The program's price, publisher, format and hardware requirements are also included. The reviews are presented in sets by topic: Word Processing, Business, Home, Education, Networking, Strategy Games, Arcade Games and Programming Aids. Spiral bound, 160pp. K0060G \$8.50

DISCOVERING KNOWLEDGEMAN

According to prestigious Byte magazine, KnowledgeMan may be the most powerful relational DBMS currently available for microprocessors- and this is a powerful introduction! After a general overview, data management and spreadsheet capabilities are examined in eight sets of detailed lessons structured to give maximum learning benefits. 342pp. K0086P \$34.95



AN INTRODUCTION TO 6502 MACHINE CODE

Starts with a general background to microprocessing and then details all of the legal 6502 instructions. Also covers the use of address modes and gives machine specific listings and sample programs. 107pp. K0178B \$7.55

amateur radio dx, communications

HANDBOOK AND RADIO, TELEVISION, INDUSTRIAL AND TRANSMITTING TUBE AND VALVE EQUIVALENTS

There is no better equivalents handbook for amateurs and servicemen. Has more than 18,000 entries listing old and new valves from the United States, Britain and the rest of Europe, Japan and the military (CV) with commercial equivalents. 93pp. N0251B \$4.95

25 SIMPLE AMATEUR BAND AERIALS

Describes how to build 25 amateur band aerials that are simple and inexpensive to construct and perform well. Projects range from the simple dipole up to a min-rhombic. 63pp. N0286B \$6.95

25 SIMPLE SHORTWAVE BROADCAST BAND AERIALS

Describes concisely the design and construction of simple and inexpensive aerials that perform well: from simple dipole to end-fire arrays. Includes dimensions and other data for spacing and cutting phasing lengths. 63pp. N0362B \$5.95

THE WORLD IN MY EARS

This is THE basic manual for anyone with an active interest in shortwave listening written by Arthur Cushen M.B.E., world-reknown authority and broadcaster. In the first section, the book covers the historical development of shortwave broadcasting and the listening hobby that grew up with it. The second section covers the practical aspects: how to start out, how to erect antennas, all about time zones, DX clubs, reporting, news sessions, etc. 204pp. N0420C \$10.95

FEDERAL MARKETING BOOK SALES

PO Box 227, Waterloo 2017

Don't miss the specials on page 101 . . .

There are concrete reasons why these are the finest speakers ever!

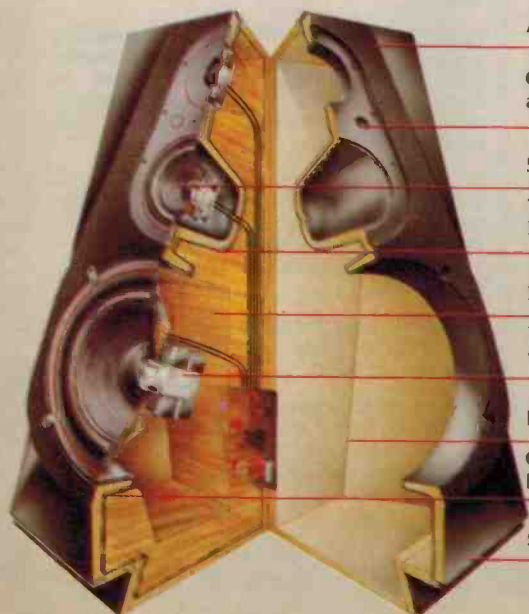
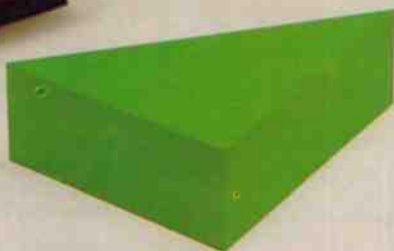

- Anti diffraction front
- Overload protection and attenuators
- 5" cone midrange
- Totally "dead" NCC concrete front
- Non-parallel cabinet
- 10" woofer with dbl. magnet
- High Performance x-over
- Centre-Bass-Reflex Phase linear front panel
- Solid built-in stand

From Jamo comes a range of loudspeakers based on the concept of an impossible-to-vibrate front baffle plate, coupled with a speaker enclosure in which no two sides are parallel.

The result is more costly to produce than conventional loudspeakers but in terms of result, the effect is literally incredible. The ability to cope with the often violent dynamics of compact disc recordings is also an outstanding feature of these speakers. You can see and hear the superlative Jamo Digital Monitor range at your nearest Jamo dealer today.

Jamo HI-FI 

For a free, most comprehensive brochure, please contact your local Jamo dealer (he is listed on the opposite page), or contact Scan Audio direct on (03)4292199.

SCOPE TOOLS

From Truscott's

MINISCOPE

PENCIL IRON WITH REAL POWER

- Adjustable wattage 10w-70w
- Adjustable heat • Fast heating
- Low voltage safety • Automatic switch off

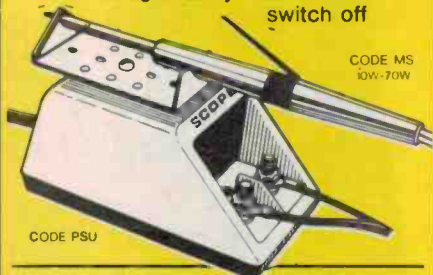

CODE MS
10W-70W

CODE PSU

SOLDER REMOVER

METAL BODY - SELF CLEANING



CODE SR

INDEXING PCB HOLDER

TILTS-TURNS & LOCKS IN 32 POSITIONS

- Rotates & locks in 45° increments
- Tilts & locks at 45°-90°-120°
- Vertical adjustment of 200mm
- Quick loading facility • Offers cross bars to 750mm.

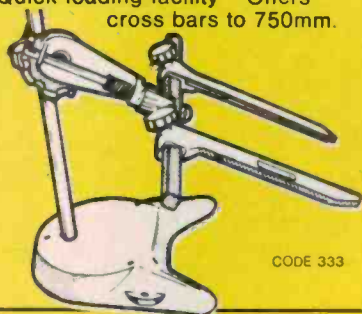

CODE 333

SOLDER BLOTTER

2 M IN WIND BACK DISPENSER



CODE
SB2 (2mm wide)
SB3 (3mm wide)

- Avoid burnt fingers because metal tipped container keeps fingers away from iron tip
- Dispenser locates tape positively

IAN J. TRUSCOTT ELECTRONICS

30 Lacey Street,
(Cnr. Windsor Street)
CROYDON, 3136
Telephone: (03) 723 3860



ETI READER SERVICE 137

ADVERTISERS' INDEX

Aiwa	4
All Electronic Components	74
Allen Bradley	81
Anitech	17
Associated Controls	76
Audio Engineers	104
Australian School of Electronics	96
Bose Australia	19
Compton Instruments	81
Crusader Electronics	IBC
Disco World	49
ETI books	97,98,101
Elmeasco	IFC
Emona	68
Emtronics	91
Energy Control	63
Geoff Wood Electronics	50
Hanimex	9
Hewlett-Packard	18
Hi-com Communications	45
Icom	82
IEI	96
Jaycar	42
Musitronics	32
Pacific Electronics	68
Philips Scientific & Industrial	104
Prepak Electronics	37
Rod Irving Electronics	24,25,57,64,65
Rose Music	10,11,IBC
Scan Audio	84,99
Scientific Devices	7
Siemens Ltd	105
Sony	113
Strathfield Car Radio	29
Truscott Electronics	84,100
Subscriptions offer	106,107
Valrian	91

MINIMART

FOR SALE: VIC-20 program library. High quality games, utilities, educational and misc programs available. Send SAE to Chris Groenhout, 25 Kerferd St, Watson, ACT 2602 for list.

FOR SALE: TO3 20X80 SCREEN 1200 baud terminal working cond \$160. DGZ80 CPU, MW640 VDU, 56K in megamemory bd, PCG bd, 32K EPROM bd 14 port I/O bd, Microbee EPROM burn, 10 slot mother bd, in rack cabinet, software, reasonable offers ring (07)285-2980.

FOR SALE: FISHER X-101-C VALVE amplifier, classic stereo amplifier. 30 watts/rms per channel, very rare unit, original condition, extra set of output tubes \$250. (02)869-1840.

FOR SALE: PHASE LINEAR 700B power amplifier, 350 watts/ch, mint condition, hardly used, superb sound, \$950. (02)869-1840.

FOR SALE: GOODMAN'S SPEAKERS, Triaxiom 1220 beautiful sound, large enclosures, only \$280 pair. Also Audiom 61, Audiom 70, Axiom 201, Triaxiom 212C, and Axiom 150 MkII from \$20 each. (02)869-1840.

FOR SALE: ACCUPHASE C-220 laboratory series preamplifier class A precision unit for moving coil and moving magnet cartridges, new price \$1980, sacrifice only \$620. (02)869-1840.

FOR SALE: MICROBEE — parallel printer cable, RS232 to Centronics interface, EPROM programmer, EDASM on 3½ diskette, BASIC and machine code tutorial cassettes. Low prices, ring Ron. Ph (02)680-3453.

FOR SALE: MICROPROFESSOR MARK I. Excellent Z80 machine code trainer. With extensive tutorials, I/O breadboard. \$110. 21 Patrick St, Klngaroy, 4610, ph (071)62-3219.

FOR SALE: NEED SPACE! Professional test gear including scopes, intel Development System, Fluke 9010A, pcb holders, etc for sale at reasonable prices. Lisa Marriott (02)450-2522.

FOR SALE: MODEM PARTS — AMI S3530 single chip modem \$27.50, 6551 ACIA \$9.50, 3.58 MHz crystal \$2, all incl, sales tax. A. Millard, 20 Chiswick Rd, Bardon, Qld 4065. (07)369-0860.

WANTED: TMS1000 24-tune doorbell chip, as used in the EA Autochime project. Please write to: S. lemma, 26 Wilding St, Marsfield, NSW 2122.

FOR SALE: OLIVETTI TES 621 wordprocessing system, consisting of VDT, keyboard, printer, dual 8" disk drives, 46 printer ribbons, 60 floppy disks, 9 (different) daisy wheels, manual, cables. Write to "Olivetti!", 238 Prospect Rd, Prospect, SA 5082.

FOR SALE: 100W/SSB TRANSCEIVER (AWA-SS220) with PSU, handbook, spares, \$600; heavy duty Daiwa rotator \$100; digital books; parts; for TAFE certificate \$50. McManamon, 103 Bunganhead Rd, Newport, NSW 2106. (02)997-1693.

FOR SALE: SERIES 5000 pre-amp, as new, built by technician. \$250 M. Maloney, PO Box 38 Dongara, WA 6525.

FOR SALE: S100/Z80 CPM 80 system, three 8" DSDD disk drives 64K RAM, 4-port serial I/O, ICL terminal, real time clock. Service manuals and software incl. \$2500 a/h (07)341-8989, bus (07) 839-9806.

Can't find it?

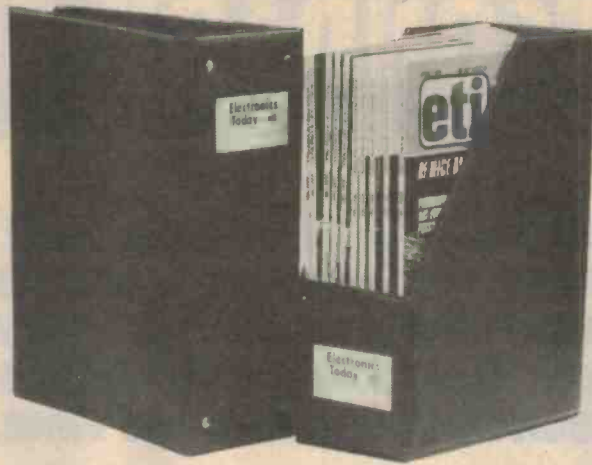

SAVE with SIX!
6 Holders — only \$37.50
6 Binders — only \$39.95

MAGAZINE BINDERS \$7.50
 Ready to use binders with easy, clip-in fastener, covered in soft, decorator brown vinyl. Holds 12 issues of Electronics Today.

MAGAZINE HOLDERS \$7.00
 Big, easy to assemble holders, covered in soft, decorator brown vinyl. Holds 12 issues (at least) of Electronics Today.

So easy to order —
 Simply return the Freepost reply card today.
 Postage and packing additional: Please refer to the reply card for charges.

File it!

MORE SPECIAL BOOKS ..

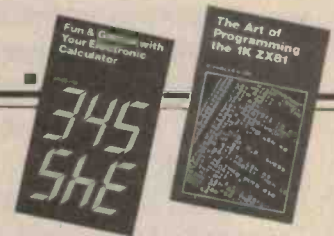

AUDIO ENTHUSIAST'S HANDBOOK

Covers the record/playback curve, stylus compliance, acoustic feedback, stereo tape track standards, compensating sideways drag, amplifier power ratings and more. \$2.75 Retail, 96pp.
G0383B

Reduced to only **\$2.00**

CHOOSING AND USING YOUR HI-FI

Provides basic information on the technical specifications of hi-fi equipment. Offers advice on what to look for in equipment in order to obtain real high-fidelity sound and reproduction. \$4.95 Retail, 88pp.
G0385B

ONLY \$3.95

THE 6809 COMPANION

This is not a beginner's introduction, but a thorough reference and discussion of the features of the 6809 microprocessor. An excellent reference! \$6.95rrp, 88pp.
J0154B

Be quick at this price **\$2.00**

THE ART OF PROGRAMMING THE 1K ZX-81

The features of the ZX-81 are explained in some detail as background to programming. These include the random number generator, graphics facilities and timer. PEEK and POKE are also explained. The well-written section on programming should make anyone with a 1K ZX-81 a whiz! \$6.75 Full Price. 86pp.
K0226B

A Rediculous **\$2.00**

ELECTRONIC CALCULATOR USER'S HANDBOOK

Formulae, data, methods of calculations, conversions and just about all the etc's are explained in detail. Explains how to calculate with only a four function calculator, including trig functions, hyperbolics, square roots and powers. 207pp.
M0245B

Hyperbollocks? **\$2.00**

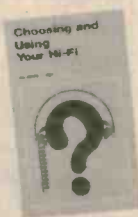

MINI-MATRIX BOARD PROJECTS

This selection of 20 useful projects to build is an excellent introduction to constructing electronic projects. Those without any experience in electronics will find it easy to read and simple to follow. \$6.75 RRP, 102pp.
D0062B

Priced to clear **\$2.00**

YOUR CALCULATOR AND YOUR MONEY

If you are interested in money and do even the simplest calculations, this book is a 'must.' It shows how to get the most practical use out of this efficient and powerful tool. The contents cover everything from simple arithmetic to compound interest, and depreciation. \$4.75 RRP, 174pp.
M0246B

\$2.00

FUN & GAMES WITH YOUR ELECTRONIC CALCULATOR

Calculators might be a powerful and time saving tool, but they can also be an endless source of amusement and an excellent source of relaxation, as this book shows. What do 55 snakes in a 14 foot square pit do? (You'll have to read page 6 to find out.) \$2.50 RRP, 63pp.
M0370B

\$2.00

THE BASIC BOOK OF HAM RADIO

This easy to read American Publication tells how the Amateur Radio Service works, how to obtain a Novice Licence, what to buy to get on the air and where the action is — awards, contests, public service, satellite communications, radio clubs and other ham activities. \$5.75 RRP, 128pp.
N0287R

Only **\$3.95**

ORDER TODAY —
Simply return the Freepost Reply Card!

1986 SECONDARY SCHOOLS

GET YOUR SCHOOL INVOLVED. YOU CAN HELP IMPROVE THE LEVEL OF AWARENESS AND UNDERSTANDING OF ELECTRONICS TECHNOLOGY AND WIN GREAT PRIZES FOR YOUR SCHOOL AT THE SAME TIME.

To enter you will need to form a group at your school to build and possibly design an electronics project. The winning school entries will be judged on the way students were involved in the theoretical and practical aspects of the competition. The only limitation on the design is that the published cost of its component parts should be less than \$100.

To help schools get tutorial or financial assistance from local companies, Electronics Today will ensure any company's assistance is advertised in a special schools page in the magazine. Schools that let us know about the progress of their electronics group will also be written up in the magazine.

Where possible the students should be involved at a circuit design level, but the competition will be judged in a way which will not penalise schools that do not have the required electronics design skills. To help these schools, Electronics Today will publish a number of project designs which can be used to enter the competition.

A complete copy of the competition rules and objectives will be made available to any school that registers its interest in the competition. Just by registering you have a chance of winning electronics products for use by your school. Copies of the rules have also been sent to either the principal or science teacher at your school.

GREAT PRIZES FOR YOUR SCHOOL

\$2000 WORTH OF ELECTRONICS FROM DICK SMITH ELECTRONICS! The winning school will get \$2000 worth of electronics for its lab. This would make a great start to an electronics lab or help equip an existing one.

25 SOLDERING IRONS FROM SCOPE! The first 25 schools to submit registration forms and then go on to complete the competition will get a soldering iron worth nearly \$30 from the leading Australian soldering tools manufacturer, Scope.

15 JUMBO COMPONENTS BAGS FROM DICK SMITH ELECTRONICS! The first 15 schools to enter the competition, whether they complete the competition or not, will win a jumbo bag of components with a retail value of at least \$75. At your first electronics group meeting you can learn how to identify common components.

MORE PRIZES THROUGHOUT THE YEAR! Electronics Today will invite other electronics suppliers to join in and offer other great prizes.

HOW TO ENTER

Schools should register their interest as soon as possible so we can keep them up to date — they will also have a chance to win electronics products just by registering.

ELECTRONICS COMPETITION

sponsored by
Electronics Today
Dick Smith Electronics
Scope



Registering brings no obligation on the school, but it allows us to supply free support material and to keep you up to date.

Entrants are required to submit a written report and hardware by August, 1986. Full details are available when you register. There will be one national winner and a finalist from each State or Territory. The judging panel will include members of the Australian Science Teachers Association, other science teachers, representatives of Electronics Today and Dick Smith Electronics. Electronics Today will have the responsibility of ensuring the fairness of the competition.

REGISTRATION FORM

COMPLETE AND SEND TO "SECONDARY SCHOOLS COMPETITION", ELECTRONICS TODAY INTERNATIONAL, PO BOX 227, WATERLOO, NSW 2017.

SCHOOL

ADDRESS

GROUP LEADER'S NAME

SCIENCE TEACHER'S NAME

DOES YOUR SCHOOL ALREADY HAVE AN ELECTRONICS GROUP OR COURSE?

MICROPHONE OF THE MONTH

...A CLOSE LOOK
AT ONE OF OUR 100



SM5B
UNI-DYNAMIC



SM83
OMNI-
CONDENSER



SM7
UNI-DYNAMIC



SM82
LINE LEVEL
CONDENSER



SM91
HALF-CARDIOID
CONDENSER



SM81
UNI-CONDENSER



SM87
SUPER-CARDIOID
CONDENSER



SM81 Studio cardioid dynamic

A superb studio AND location mic

The SM81—a legend in its own time—is singularly immune to the problems that plague traditionally-designed condensers. It withstands extremes of temperature, humidity, and physical punishment while maintaining long-term stability... at an affordable price. It is outstanding in a studio environment and incomparable in location applications.

Exceptional accuracy, "Reach," & discrimination

The SM81's extremely wide-range, flat frequency response and precise cardioid polar pattern, wide dynamic range, low handling and internal electrical noise, and superior low distortion characteristics make it most "user friendly," and a delight among audio technicians. Selectable low-frequency response compensates for proximity effect or low frequency disturbances. One of a kind... From Shure, of course.

Write:
Audio Engineers P/L 342 Kent St.
Sydney, 2000 (02) 29 6731
Audio Engineers Qld. (07) 44 8947
Marketec (WA) (09) 242 1119

Sound of the professionals
SHURE®

ETI READER SERVICE 138

Compact DMM's...

...with real testbench performance

Philips Series 18 DMMs give you a magic combination — no-compromise testbench features and performance, packaged in a choice of three compact, easily portable instruments that are always handy for lab, workshop or field use.



Our range of three models lets you select exactly the functions you need for every application and environment.

PM 2718

min/max, auto data
hold, 100 kHz RMS AC,
0.05% DC

PM 2618

electronic calibration,
200 kHz counter, 0.3%
bargraph and 10 MHz
logic view

PM 2518

RMS AC,
direct temperature,
dB and relative
measurements

Contact Philips Scientific & Industrial.

SYDNEY: Box 119
North Ryde 2113
Tel. (02) 888 8222
(Toll free (008) 22 6661)

MELBOURNE: Locked bag No. 5
Oakleigh South 3167
Tel. (03) 542 3600
(Toll free (008) 33 5295)



PHILIPS

ETI READER SERVICE 120

SIEMENS

VARISTORS

**Australia's widest range.
All applications. Biggest stocks.
Lowest prices. Quickest delivery.
What else?**

Siemens is now the biggest and best source of varistors in Australia with a full size range for all applications up to 70 kA. This is of special interest to the telecommunications industry. Comprehensive stocks, plus Siemens position as one of the world's largest manufacturers of varistors underwrites our promise of quick delivery and suitability.

Siemens innovation aims at achieving substantial cost reductions across a wide spectrum in the following applications:

- Power engineering
- Electronic communications
- Power electronics
- Measuring technique
- Processing technique
- Office electronics
- RFI suppression
- Stepped protection

This wide range of varistors is available through Siemens newly strengthened national distributor network. For further information, post the coupon or phone your nearest distributor.

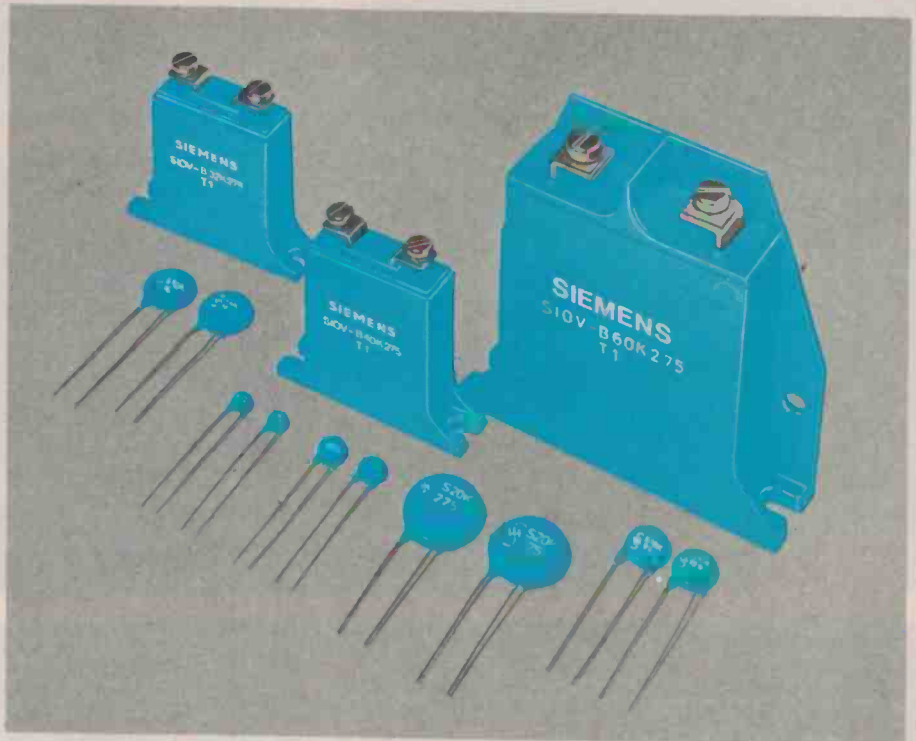

Distributors

Victoria: Promark Electronics (Vic)
(03) 878 1255

New South Wales: Nexus Electronics Pty Ltd
(02) 439 5800

New South Wales: Promark Electronics Pty Ltd
(02) 439 6477

Queensland: ECQ Electronics
(07) 376 5677

South Australia: R.G. Pank Pty Ltd
(08) 51 2411

South Australia: Protronics Pty Ltd
(08) 212 3111

Western Australia: Reserve Electronics
(09) 328 9755

New Zealand: Delphi Industries Ltd
Auckland 563 259

Siemens Ltd.

544 Church St., Richmond, Vic.
Melbourne: 420 7318 Sydney: 436 8730
Brisbane: 369 9666 Perth: 362 0123

Please mail me the new Informative varistors brochure.

NAME

TITLE

COMPANY

ADDRESS

STATE..... POSTCODE.....

Post this coupon now to Siemens Ltd.
Advertising Department, Melbourne.
544 Church St., Richmond 3121.

INGENIOUS ELECTRONIC ENGINEERING

WIN

A SENSATIONAL 4 WHEEL DRIVE DAIHATSU 'ROCKY'!



EVERY NEW SUBSCRIBER WILL ALSO GET A FANTASTIC 35mm CAMERA (Valued at \$25) absolutely FREE!!

Imagine ... you'll receive 12 feature-packed issues of Electronics Today, Australia's dynamic electronics magazine (delivered to your home FREE). Plus – you'll also get a FREE 35mm Camera (worth \$25)!!

AND THAT'S NOT ALL ...

**YOU COULD ALSO WIN A DAIHATSU 'ROCKY' 4WD, LONG-WHEEL-BASE DIESEL WAGON.
ALL FOR JUST \$30! Now that's real WINNING VALUE!!**

YES! YOU COULD WIN 'ROCKY' (Worth over \$21,500)

With this powerful 4 Wheel Drive vehicle, you'll always be where the action is! Just look at the incredible FEATURES:

- Power Steering • 3-Way Suspension • AM/FM Stereo Radio/Cas. • Tilt Steering • 215 SR Wide Tyres & Wheels
- Carpeting Throughout • Full Fabric Seats

PLUS ALL THESE SPECIAL EXTRAS:

- Bull Bar • Tow Bar • Side Steps • Weather Shield • Exterior Striping • Sunroof • Headlamp Covers

PLUS A UNIQUE PAINT JOB – ONLY ONE OF ITS KIND!!!

(The vehicle is the same one shown on this page)

**CLAIM YOUR
FREE GIFT TODAY!**



FREE!



YOUR FREE GIFT!!

This versatile, go-anywhere camera takes superb 35mm colour slides or prints (also black & white).

FEATURES: • Automatic focussing • Automatic digital frame counter • Simple to load • Easy to use exposure settings • Sports grip • Soft push button • Flash facility • Tripod socket.

INCLUDES: • Durable, good looking body • Fine 50mm lens • Lens cover • Handy shoulder strap • Zip-up protective carrying case • AND A FULL 12 MONTH GUARANTEE

NOW YOU'LL ALWAYS HAVE A RELIABLE CAMERA ON HAND WHEN YOU NEED ONE!

An excellent second camera for you . . . or an ideal gift for the kids.

NOW, ALL THAT ADDS UP TO AN OFFER YOU JUST CAN'T REFUSE!! BUT HURRY! This is a limited offer . . . YOU MUST ACT NOW!!!

HOW TO WIN, AND CLAIM YOUR FREE GIFT:

Simply complete your special PRIVILEGE OFFER SUBSCRIPTION CARD between pages 82 & 83, and mail it

FREE POST (no postage stamp required) to us. We'll automatically send you your FREE camera with your first issue . . . and your name will be entered into the draw to WIN the DAIHATSU 'ROCKY'.

YOUR NO-RISK GUARANTEE

If, for any reason you are not completely delighted with the magazine . . . simply let us know, and we'll gladly refund the unused portion of your subscription.

(Offer valid until 30 April, 1986. All Federal Publishing New Subscribers during Feb., March and April are eligible to win)

DON'T DELAY . . . MAIL YOUR SUBSCRIPTION CARD TODAY TO RECEIVE YOUR FREE GIFT!

If the Subscription Card has been removed, please write to:

ELECTRONICS TODAY

FREE POST No. 4 (No postage stamp is required)

The Federal Publishing Co. Pty Ltd

P.O. Box 227, Waterloo, NSW 2017

VOYAGER AT URANUS

Jon Fairall

Early on the morning of 25 January the Voyager spacecraft, 4954 million km and 3074 days from Earth, swept past the planet Uranus, sending back some 1600 pictures and thousands of other pieces of information as it did so. During the four and a half hour encounter it generated more new knowledge about the planet and its retinue of satellites than mankind has been able to glean from the 204 years of patient earthbound observation since its discovery.

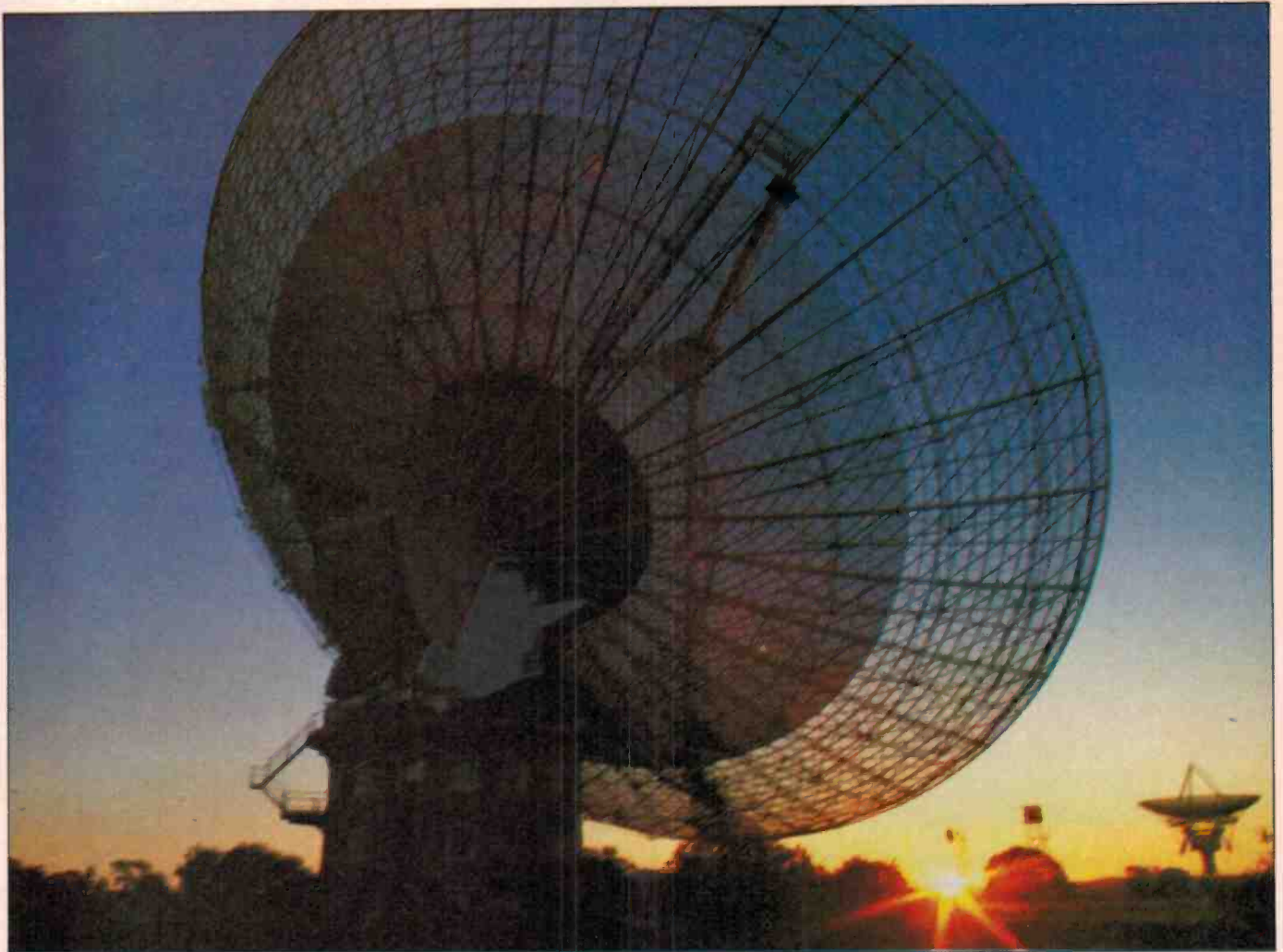

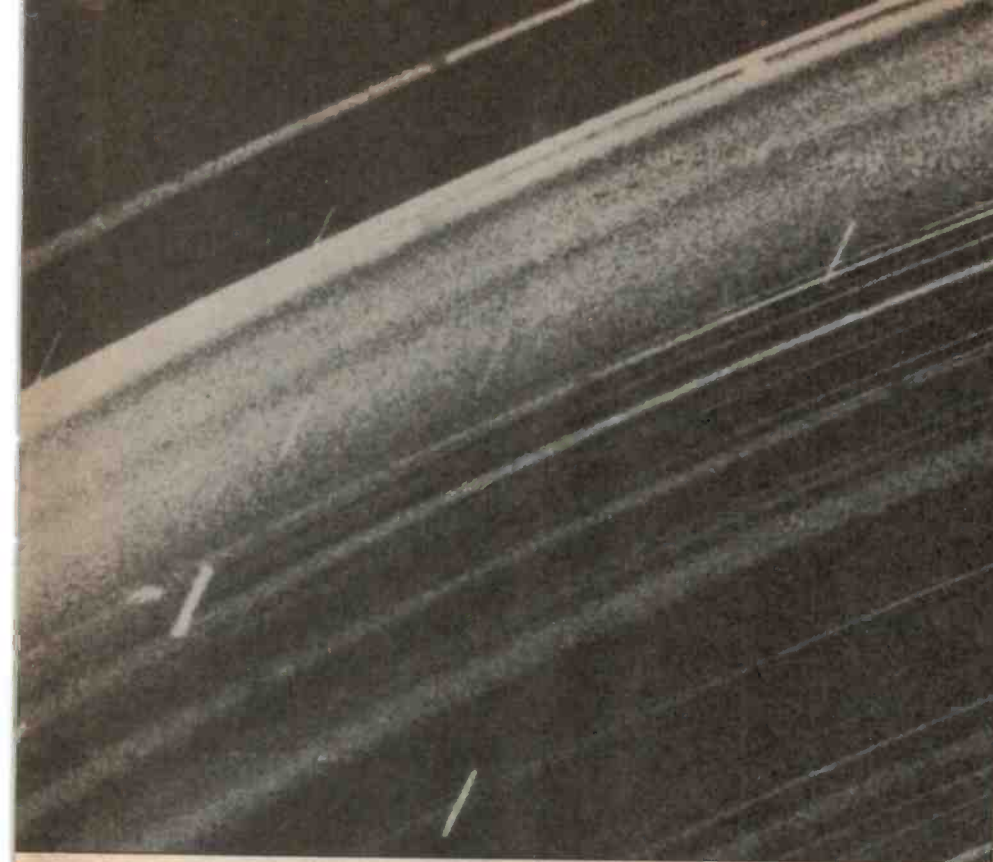

Left. The rings of Uranus. Voyager 2 was 236,000 km from the planet, looking back at sunlight refracted by small dust particles in the rings when this was taken. The streaks are stars, caused by panning the camera during the 96 second exposure.

Far left: Receiving pictures from Voyager. As the sun came up on the 24 January, Parkes was well positioned to receive incoming data from the other side of the solar system.

ON THE NIGHT of 13 March 1781, music teacher William Herschel got rid of the last of his pupils and hurried out into his garden to satisfy the real passion of his life: looking at stars. By any standard he was good at his hobby, he put a lot into it, and got a lot out. But that night, he was rewarded beyond the dreams of most amateur astronomers; he discovered a new planet.

Herschel's diary, preserved to this day, records that he saw "a curious nebulous star or perhaps a comet" in the constellation Gemini. The idea of a new planet never entered his head, and indeed, there was no reason why it should have. The size of the sun's family had remained fixed since ancient times and whatever controversies may have surfaced during the preceding hundred years, expanding the scale of the solar system was not one of them. But tracking its orbit over subsequent nights, he realised that the 'comet' was moving in a most uncomet like orbit. Two weeks later the Astronomer Royal confirmed the existence of a new planet, to be known as *Georgium Sidus*, in honour of King George.

European astronomers demurred, not unnaturally. It was left to the astronomer and mathematician Johann Bode to note that the outer planets are named for the deities of the ancient Greeks and Romans. In fact, travelling outward through the solar system takes one from Mars to his father, Jupiter, and then on to his father, Saturn. So the logical step was to name the new planet for Saturn's father: Uranus.

Uranus observed

After the excitement of discovery had died down, Uranus turned out to be a pretty dull planet. Seen through earthbound tele-

scopes it turned a bland face to the universe. As recently as last year the best pictures we had showed a blank disc, perhaps a few faint markings, and precious little else.

Some facts emerged. It was about 51,000 km in diameter, about four times bigger than the Earth. It subtends an angle of just four seconds of arc in the sky, making it a small target for all but the biggest telescopes. It was tilted on its side at a ridiculous angle so that first one pole, then the other, would point at the sun. Meteorologists speculated on the effects that would have on the planet's weather. Suggestions were that it would be distinctly odd.

Its day was estimated to be 18 hours long. The bland atmosphere made it difficult to observe regular changes in light and dark on the surface however, so the figures were quoted with a great deal of hesitation. Some observers claimed to have measured rotation figures as low as 11 hours.

Five moons were identified. All were named for characters from English literature. Oberon and Titania come from Shakespeare's 'A Mid Summer Night's Dream', Ariel and Umbriel from Pope's 'The Rape of the Lock'. The last to be discovered, Miranda, closest and faintest of the five, was named for the heroine of 'The Tempest'.

After the manner of astronomers, various models of the inside of the planet have been tried that fit the known physical facts of Uranus. Current wisdom holds that there is a rocky core about two or three times the size of the Earth, surrounded by oceans about 8000 km thick. The water slowly gives way to layers of methane and ammonia. Under the enormous pressure of the overlying atmosphere the gas is squeezed

slowly into liquid form, so there is no clear interface between the liquid and the gas. Your sons and daughters will never sail a boat on Uranus. The visible surface is mostly hydrogen and helium, with occasional colouration due to clouds of methane.

This is the received view. However, more bizarre explanations have been offered. The centre of the planet might be hot enough for methane to be breaking up into carbon and hydrogen. The carbon atoms would join together as crystals of diamond and the hydrogen would be liberated into the atmosphere. So Uranus could have a massive diamond at its centre.

Uranus has one characteristic that sets it apart from all the other large gas planets. It appears that it has no internal source of heat. Not that it's cold; quite the opposite. Its oceans act like a gigantic thermostat to make it the only place outside the Earth with a temperature that would be amenable to human occupation.

In 1977 scientists started to take a fresh look at Uranus. Jim Elliot, one of the leading lights of current US astronomy, watched a star disappear behind the planet. It's a technique called occultation. By doing occultation experiments, watching how a known source of light interacts with a strange body, astronomers can learn a great deal.

Elliot was interested in studying the Uranian atmosphere. What he found instead was a pattern of nine rings, each a few kilometres across. The rings were extremely dark, so much so that only a few direct photographs have ever been taken. Up until that time rings were thought to be a feature of Saturn only, but the discoveries on Ura-

nus prompted a search for similar structures on other planets. Voyager 1 discovered a system around Jupiter, and researchers at Wollongong University have discovered them around Neptune as well.

And of course, in 1977 another event

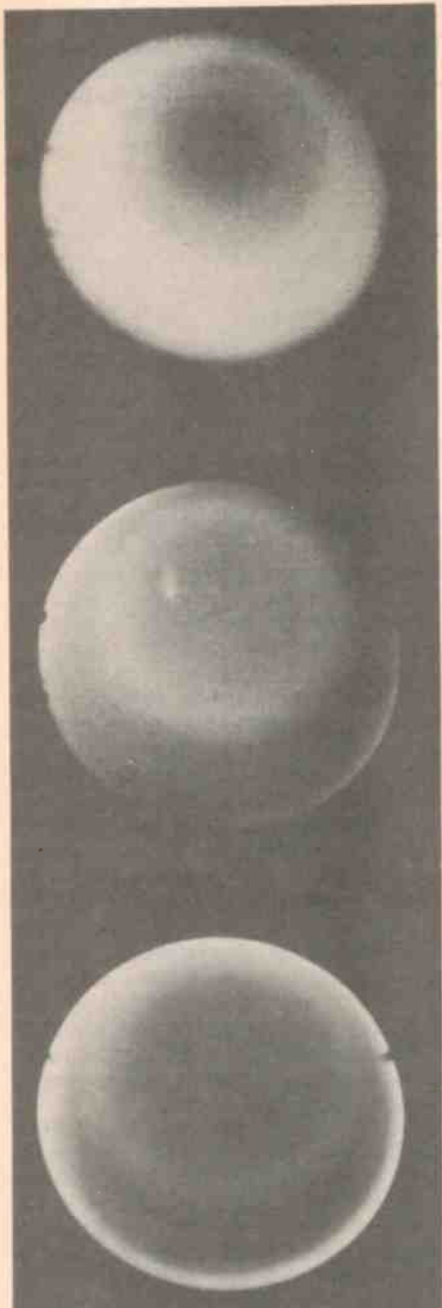

Colour Imaging from Voyager. These three computer enhanced images of Uranus, taken from 2.1 million km, show the view through violet, orange and methane filters. Later they can be combined to provide a composite colour image. These images are themselves quite removed from the originals received at Parkes. JPL uses a correlation technique, in which each picture is broken up into its discrete pixels, and then copied time and time again.

took place that was to have profound consequences for our knowledge of the enigmatic planet. At Cape Canaveral, Voyager 2 was launched and began her long journey through space.

Voyager

The most prominent feature of Voyager itself is the large radio antenna, which is always pointed back at Earth. Two receivers, a transmitter, six small computers and a few scientific instruments are bolted to its back. Power is provided by a small generator which uses the heat of decaying radioactive isotopes.

Today Voyager's computers would be the subject of amused curiosity. When it was launched they were the very latest in high tech. Each one consists of a customised central processor surrounded by about 44K of memory. All the hardware is made up of NMOS military standard high reliability chips.

The computers are organised into three groups of two each. In order, there is the computer command subsystem (CCS), which interprets ground commands and executes them, the flight data subsystem (FDS) which organises data from the instruments for transmission to Earth, and the attitude and articulation control subsystem (AACS) responsible for maintaining the orientation of the spacecraft, tracking the sun and stars, and operating the camera platform.

The CCS is the linchpin of the electronic architecture of Voyager. It controls all the other parts of the craft, including the other major subsystems. It is responsible for allocation of resources around the spacecraft, and has sufficient intelligence to be able to fly the craft without help from Earth. In fact it has a routine that will allow a rudimentary encounter with a planet and the transmission of some data to Earth even if it loses contact with Earth completely. Ten per cent of its memory space is taken up with protection algorithms that protect it against mismanagement from Earth or loss of contact. For instance, certain combinations of loads tax the power supply, and if Mission Control inadvertently attempts to switch in this combination, the CCS can stop it.

In addition the CCS controls a digital tape recorder and the radio. The tape recorder was a model of state of the art engineering when Voyager was launched. It can store up to 96 video images as PCM data on its tape. Bit rates can be set between 7.2 k/bits and 115.2 k/bits.

The FDS is responsible for looking at information coming back from the spacecraft sensors and converting it into a data stream for transmission to Earth. The sensors include twin cameras, one with a 1500 mm lens, the other 200 mm, infrared and ultra violet sensors, a photopolarimeter for mea-

suring light intensity, a pair of 'rabbit ears' that form the radio astronomy experiment, a magnetometer for detecting magnetic flux, and detectors for plasma, low energy particles and cosmic rays.

Naturally, the most resource hungry of these devices is the imaging system. Its 800 x 800 pixel images, each 8 bits wide, require 5 Mbits to describe a full picture. It requires substantial amounts of time on the transmission link and large amounts of tape space in the recorder. This requirement was alleviated recently by reprogramming the FDS to use a delta modulation technique instead of pulse code modulation for imaging.

The AACS can be broken down into attitude sensors and thrusters. The attitude sensors consist firstly of on-board gyros, secondly of a number of cameras that point at various astronomical objects. One is usually pointed at the sun, another points usually at the star Canopus, and another at the astronomical object of interest. Using these three sensors the AACS can accurately compute the craft's stability at any given time.

Attitudinal control is effected firstly by the gyros. The craft can actually be made to turn by placing forces on the gyro axes. A more powerful method of reorienting the craft is to use hydrazine thrusters, of which there are several scattered around the craft. Obviously hydrazine is a non-renewable resource, so it is used sparingly.

Operation

The standard method of operating the spacecraft is to write a program called a 'load', which is transmitted to the CCS. A CCS load consists of a series of instructions that control all aspects of the spacecraft performance. The programs are written in a custom language which is composed of words that detail firstly the target subsystem, then the activity it is to perform. As a result Mission Control does not need to operate the spacecraft directly, but uses the computer system as an intermediary.

In normal operation there might be only one of these loads a month. This quickens as encounter nears. There were four CCS loads during the Uranus encounter and two immediately afterwards. The last one included a set of limited objectives for the Neptune encounter. It's called playing safe!

Old age

The result of all this extensive software control is an exceptionally durable craft able to withstand all the vicissitudes of 10 years in space and still remain usable. But Voyager's hardware is starting to fail. One of the two radios has broken down, the other doesn't work very well. The drive system for the camera platform, which once used to pan and tilt like a remote TV camera in a studio, is now stuck uselessly. Voya-

ger's memory is failing. A bank of 256 bytes has already failed, another 512 is suspect.

Trouble with the radio began on 16 April 1978, when a failure protection algorithm in the FDS detected that no signal had been received for a week. The FDS had been programmed to take this as a sign that the radio had malfunctioned, and so to switch to backup, which it did. This monumental blue by JPL controllers was caused by them simply forgetting to talk to Voyager 2 because of problems with Voyager 1.

When Mission Control woke up it was horrified to find that a capacitor in an automatic frequency control circuit of the backup receiver had failed, depriving the receiver of the ability to track the frequency of the Earth based transmitter. They attempted to return command to the prime receiver, only to find that the prime itself had failed completely. It then took another seven days for the FDS to switch on the back-up again.

Since Mission Control will never get its hands on the hardware it's impossible to be sure about what went wrong with the radios. However, all the current characteristics can be explained by assuming a supply of dud capacitors.

In the meantime controllers have learned to live with the crippled back-up radio. They now adjust the frequency of the deep space network tracking stations to keep in touch. They have learnt that the reception frequency is critically dependent on temperature and now predict how reception frequency will change as a result of reorienting the spacecraft, or turning systems on or off. Nevertheless, engineers at JPL are constantly aware of living on borrowed time. They realise that every message they send might well be the last, and plan accordingly.

Another problem: during the Saturn encounter the actuators on the camera table failed. The assembly consists of a small stepper motor, driving a nylon belt. Originally the table seemed to be stuck solid, but later engineers at JPL were able to generate some movement. They have been feeding the stepper motor with very small pulses and using the resultant slew of the camera mounting as a measure of the resistance of the nylon belt.

It seems that the problem is caused only by rapid motion, leading engineers to hypothesise that the fault is simply one of inadequate lubrication. The problem is not critical, as it turns out. It is possible to make all camera movements slow and deliberate, and to assist by rotating the whole craft when necessary.

Parkes

Of course, none of this would have been discovered without electronic ears on the ground capable of receiving the signal from space. These form the DSN, the Deep

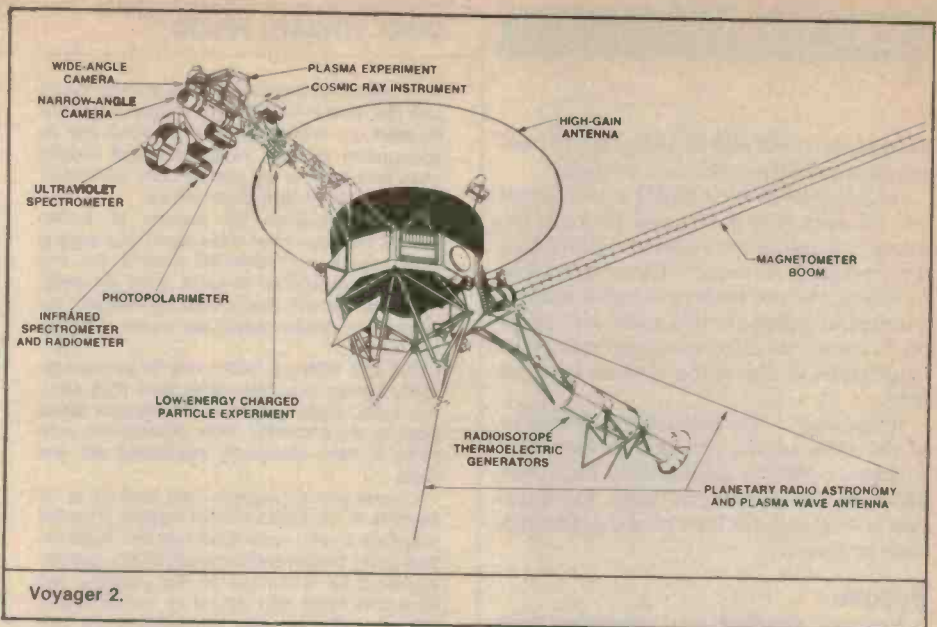

Voyager 2.

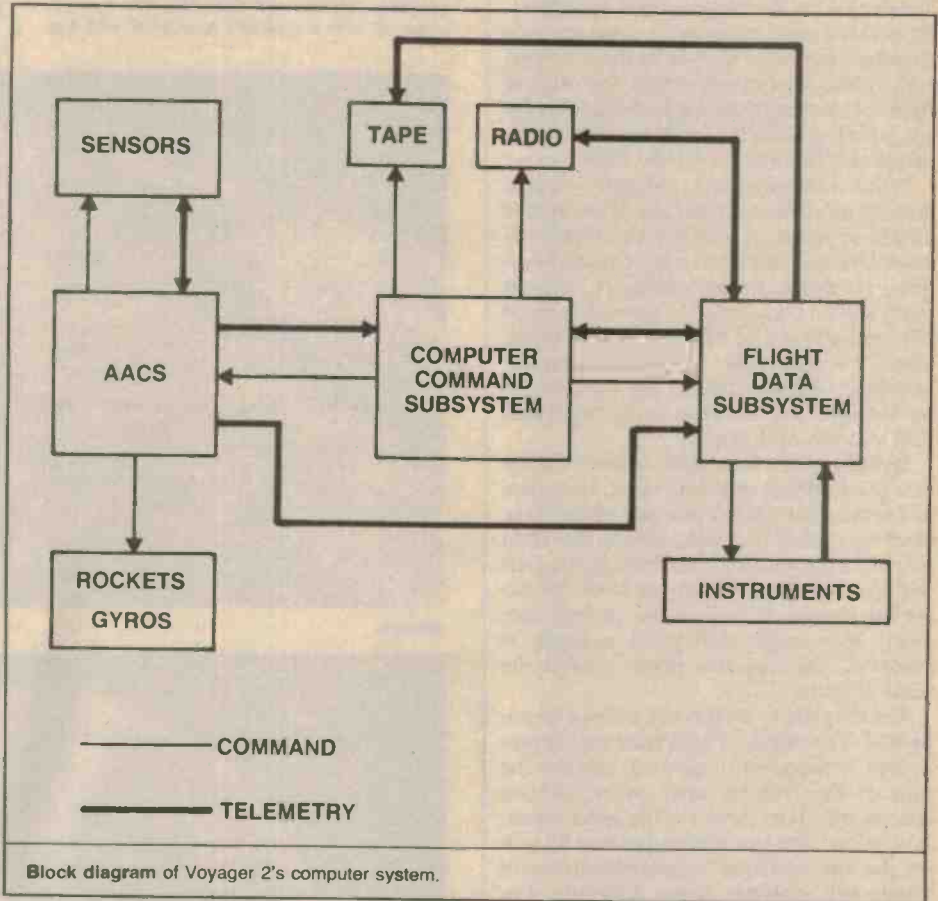

Block diagram of Voyager 2's computer system.

Space Network, which consists of three large radio telescopes located on opposite sides of the Earth, at California, Madrid and in the ACT at Tidbinbilla.

But for the purposes of receiving information from Voyager it was necessary for NASA to call in outside help. Its signals are now so faint that dishes of the DSN have difficulty receiving them at anything like the reception rate required during the brief Uranus encounter.

So NASA turned to the CSIRO. Its huge telescope at Parkes is just 320 km from Tidbinbilla. The telescope has had a long and distinguished history since it was opened in 1960. Most noteworthy for the general public: Armstrong's moon walk was received here back in 1969. According to director Jon Ables it is still one of the best designed and built telescopes in the world. Modifications to the dish and new reception equip-

FEATURE

ment mean it will still be doing world class astronomy well into the next century.

NASA offered the CSIRO a permanent link between Tidbinbilla and Parks in exchange for use of the Parkes facility during the Voyager 2 encounter. The idea was that by linking the two telescopes together using a technique called interferometry, it's possible to create the effect of a huge radio telescope equal in size to the distance between them.

In the event, the improved performance of the DSN meant that the bit rate from Voyager could be substantially increased. This led to, amongst other things, the reception of 1600 pictures instead of the 600 originally proposed.

Future

Voyager survived the encounter with Uranus intact. It swung around the planet, accelerated and sped on its way towards Neptune, the outer marker of the solar system. (Pluto is currently within the orbit of Neptune, leaving Neptune furthest from the sun.) If all goes well, it will begin its observations of Neptune on 5 June 1989.

When it finishes there, Voyager will face nothing more than an eternity in the frozen wastes of space. It will not be completely alone however, for some time. From time to time, no doubt, young engineers, not yet born, will be taken into the control room at JPL and allowed to turn on the transponders of the spacecraft. Unless there is a catastrophic electronic failure, the transmitters on Voyager will continue to be receivable well into the next century.

Its final job for its makers will be to serve as a gravitational sounding buoy. Its course out of the solar system, like that of the three planetary probes that went before, has been planned exactly. Scientists tracking the craft will look for small deviations from the expected course. If any of the probes veer away, they might well point a finger at Planet X, the supposed planet outside the orbit of Pluto.

But the time to do this job will not be unlimited. The supply of hydrazine rocket propellant is expected to give out around the turn of the century, after which attitude control will have to be via the gyros alone. About 2023 the sun sensor will lose its lock on the sun and thus communication with Earth will become more difficult. The power supply necessary for functioning of the craft will last no longer than 2015, but it is likely that reserves will be available to run the receiver for considerably longer than that. Scientists believe that down-link telemetry will be available at 20 bits per second until about 2165. They should theoretically be able to command Voyager, using a 70 meter dish with a 400 kW transmitter, until 2217.

WHAT VOYAGER FOUND

As it blasted through the Uranus system, taking just four and a half hours, Voyager effectively doubled our knowledge of the planet and its surrounding moons. Sixteen hundred images were sent back to the waiting radio telescopes in south eastern New South Wales.

Voyager doubled the number of known moons. No large ones were found, but several small objects were detected close to the ring system. It is believed some of these are shepherds, ie, moons responsible for keeping the rings intact. Similar moons are known of Jupiter and Saturn.

Voyager added a further ring to the nine already known. It turned out to be a thick tenuous thing, barely visible in photographs taken close to the encounter. More pronounced were lanes of dust, apparently interleaved with the rings.

Uranus has a magnetic field inclined at 55 degrees to its visible axis of rotation. Puzzled scientists at JPL speculated that this might reflect some fundamental anomaly in the underlying structure of the planet. For instance, the inner core might spin around an upright axis of rotation while the outer atmosphere and surrounding satellites are tilted. No one has yet come up with a coherent account of why this

should occur but, on the other hand, a magnetic field tilted at 55 degrees upsets most conventional explanations of why magnetic fields occur in planets at all.

But by far and away the most fascinating results up to now have come from Voyager's brief look at the satellites. All of them were imaged by Voyager, some to a spectacular degree of resolution. For instance, the photograph of Miranda, shown here, resolves features only 600 metres in length. This image was taken without a filter, and reveals massive mountain ranges several kilometres in height, in spite of the moon's small diameter, only 31,000 km.

The other picture here shows Titania, the largest satellite at 1600 km diameter. Maximum resolution is 13 km. Notice the massive fault valley, 1500 km long and 75 km wide. The bright streak on one side of the valley is believed due to deposits of frost reflecting the sunlight. Titania also appears to have been hit by massive meteorites in the past. The crater at right is 300 km across. Before this image was received, scientists knew little about this world. It appears as a blob of light through even the best Earth-based telescopes.



Miranda

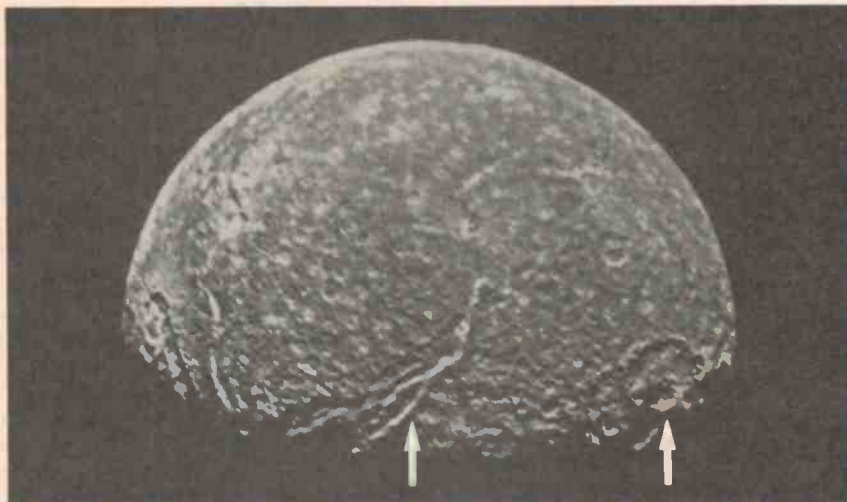

Titania

Sony apologises for rendering your car stereo obsolete.



The humble car stereo cassette player has been humbled.

The Sony CDX-R7 Car Compact Disc Player is not only markedly superior to every conventional car stereo you've ever heard, it is markedly superior to most home stereo systems. Never again will driving be an excuse for inferior sound quality.

The Compact Disc is ideally suited to creating the concert hall in your motor car. It creates astonishing fidelity, with negligible wow and flutter. It allows up to 60 minutes of music on a disc - uninterrupted or with instant track selection access - with fingertip controls for ease of use while driving.

The Sony CDX-R7 features include: AM/FM stereo tuner, 18-station pre-set manual or auto-scan tuning, repeat play/pause buttons, disc storage and digital clock.

With Sony's Compact Disc technology in your car, you will experience something approaching audio perfection: sound quality that is so noticeably superior to anything you have ever heard from a car stereo cassette before, that it will render even the finest conventional stereo cassette player ... well, obsolete.

COMPACT
disc
DIGITAL AUDIO

SONY®

SHARE THE VISION

Born to be alive

by Paul Jones

SHE WAS PAID very well, for the little pain she had to endure. Every year she returned to the Centre with a new offspring, no mutants, just well-formed babies. That's all she did to sustain herself in a well-to-do manner; she only had to ignore the stares of people wondering if she was always fat or just in a family way . . . again?

SMITH, David John. Born 15 July 1993. Mother: 30011560. Defects: nil. Eyes: blue, 6/6. Skin: light. Hair: blonde. Implant: Type 308, MK3.

He felt lucky that he has been brought up by the new education department, they gave the best schooling and kept his body in great shape. He remembered when playing football he broke a rib. They whisked him off to hospital and had the best doctors repair his body. So lucky was he. He joined the Troop Reserve, as was recommended by the department, and here he found many other people helped by the department. He was happy, they were happy.

Dave welcomed the constant pressure of

training and exercise that was dished out by his supervisors; he was fit and the work was easy. Over the years Dave moved up through the ranks and as he progressed the pressure changed slowly from physical to mental strain. They were testing his brain power now and Dave was improving.

After a few years he had noticed that information from the outside world was becoming very general, very few political events and more 'folksie' things; but pressure was building up and he soon had little time for things outside his rank.

One day he was taken away to the hospital for some skin and blood tests. He asked their purpose but received only a mumbled reply. A few days later the Implant simulated a heart attack and within a day he was recovering in hospital.

The tired eyes of Dave opened, he looked around as best he could, only to see a large, throbbing machine, keeping his life going. Dave panicked, and the machine throbbed harder, linked to his brain by the Implant placed there years ago.

After a month he was transferred to Rehab and given a quiet clerical task and a scaled-down version of the large machine

that he had first sighted a month before. In an office 20 kilometres away a departmental head was being welcomed back to the position he left suddenly a month ago, his new heart pounding away in his chest. The head was in wonder at the speed at which a donor was found and insisted that the family of the traffic accident 'victim' be given increased compensation. This was never done, but he knew nothing of the result.

It seemed to Dave that this was the beginning of the end; within three years he had developed 'cysts' on his optic nerves. This led to the removal of his eyes. At the same time an elder statesman was given the gift of new vision, donated again by the same traffic 'victim'.

Dave 'donated' a section of his brain, after a 'stroke', gave a senator relief from a brain destroying tumour, restoring at least part of his lost mobility.

Dave died at the young age of 45, he left no friends or family, but, after use in extensive medical studies, his body was discarded with full military honours and was shown as an example to others of loyalty and devotion to duty.

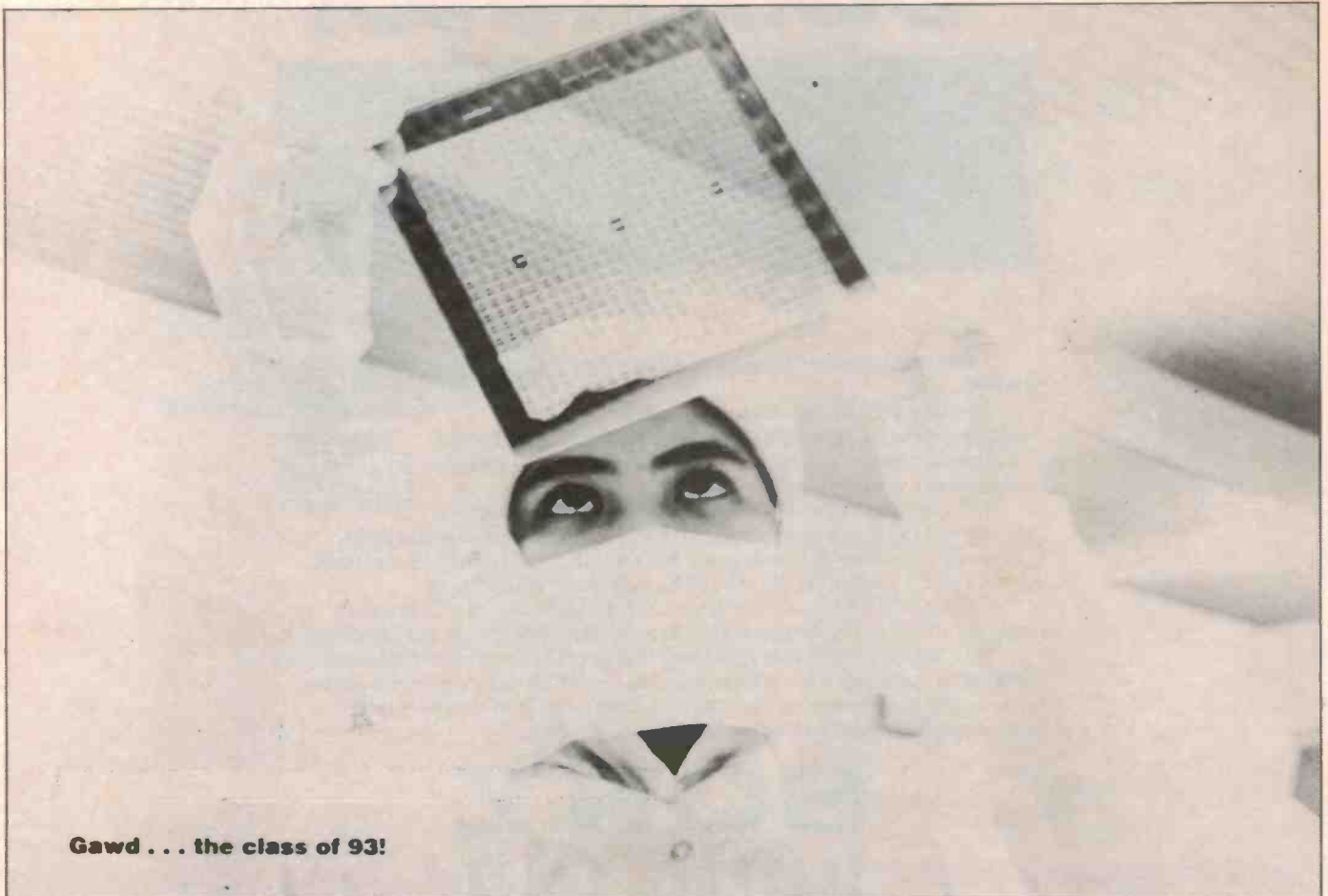

Gawd . . . the class of 93!



SMD-RESISTORS

FOR PROFESSIONAL ELECTRONICS



BEYSCHLAG Metal Film Resistors »Harmonic Series«

Version	Temperature Coefficient	Tolerance
STANDARD	TC 100	5% - 2%
PROFESSIONAL	TC 50-25	1% - 0,5%
PRECISION	TC 25-15	0,25% - 0,1%
Style	Rated Dissipation P70	Resistance Range
MBA 0204 - BX	0,4 Watts	0,22 Ω - 10 MΩ
MBB 0207 - BX	0,6 Watts	0,22 Ω - 10 MΩ
MBE 0414 - BX	1 Watt	0,22 Ω - 22 MΩ

IEC Series

E 24	E 96	E 192	E 24	E 96	E 192	E 24	E 96	E 192	E 24	E 96	E 192	E 24	E 96	E 192
10	100	100	147	147	215	215	316	316	470	470	681	681	681	681
	101		149		218		320		475		698		698	698
	102	15	150	150	22	221	221	324	324	475	475	698	698	698
	104		152		223		328		481		715		715	715
	105	105	154	154	226	226	332	332	487	487	715	715	715	715
	106		156		229		336		493		723		723	723
	107	107	158	158	232	232	340	340	499	499	732	732	732	732
	109	16	160	160	234		344		505		741		741	741
11	110	110	162	162	237	237	348	348	511	511	750	750	750	750
	111		164		240		352		517		759		759	759
	113	113	165	165	243	243	357	357	523	523	768	768	768	768
	114		167		246		361		530		777		777	777
	115	115	169	169	249	249	365	365	536	536	787	787	787	787
	117		172		252		370		542		796		796	796
	118	118	174	174	255	255	374	374	549	549	806	806	806	806
	120		176		258		379		556		816		816	816
	121	121	178	178	261	261	383	383	562	562	825	825	825	825
	123	18	180	180	264		388		569		835		835	835
	124	124	182	182	267	267	392	392	576	576	845	845	845	845
	126		184		27		397		583		856		856	856
	127	127	187	187	274	274	402	402	590	590	866	866	866	866
	129		189		277		407		597		876		876	876
	130	130	191	191	280	280	412	412	604	604	887	887	887	887
	132		193		284		417		612		898		898	898
	133	133	196	196	287	287	422	422	62	619	619	91	909	909
	135		198		291		427		626		920		920	920
	137	137	200	200	294	294	432	432	634	634	931	931	931	931
	138		203		298		437		642		942		942	942
	140	140	205	205	301	301	442	442	649	649	953	953	953	953
	142		208		305		448		657		965		965	965
	143	143	210	210	309	309	453	453	665	665	976	976	976	976
	145		213		312		459		673		988		988	988

RANGE OF VALUES TEMPERATURE COEFFICIENTS TOLERANCES
 0 OHM - 10 MOHMS TC 15-TC 100 0,1% - 5%

Colour coding for Beyschlag Mini-Melf - as is usual for resistors with leads - with 4 or 5 colour bands for resistance value and tolerance.

* is not used for 4 band coding

EXAMPLE: 37,4 KOHM ± 1% TC 50

BEYSCHLAG GmbH - P.O. Box 12 20 - D-2240 Heide
 Telephone 481-950 - Telex 28801 - Telefax 481-95209



Metal Film Resistors »Harmonic Series« STANDARD
 Metal Film Resistors »Harmonic Series« PROFESSIONAL
 Metal Film Resistors »Harmonic Series« PRECISION
 Carbon Film Resistors STANDARD



Colour coding according to IEC Publication 62 and DIN 41 429

band 1	band 2	band 3	band 4	band 5	colour dot
0	0	x 1			
1	1	x 10			
2	2	x 100	± 2%		
3	3	x 1 k			TC 15
4	4	x 10 k			TC 25
5	5	x 100 k			± 0,5%
6	6	x 1 M			± 0,25%
7	7				± 0,1%
8	8	: 10			
9	9	: 100			

Example: red - violet - orange - gold = 27 k Ω ± 5% TC 100

Example: red - violet - yellow - red - brown = 27,4 k Ω ± 1% TC 50



CRUSADER ELECTRONIC COMPONENTS PTY. LTD.

81 Princes Highway, St Peters NSW 2044. Phone (02) 519 5030, 516 3855, 519 6685. Telex AA23993 Code: CRUSAD Distributors: Sydney George Brown & Co. Pty. Ltd. Phone 519 5855; Geoff Wood Electronics Pty Ltd 810 6845. Wollongong Macelec Pty. Ltd. Phone 29 1455. Canberra George Brown & Co. Pty. Ltd. Phone 80 4355. Newcastle D.G.E. Systems Pty. Ltd. Phone 69 1625. Melbourne R.P.G. Agencies Pty. Ltd. Phone 439 5834; Jesec Components Pty. Ltd. Phone 598 2333; Rosnik Distributors Pty. Ltd. 720 3370. George Brown & Co Pty. Ltd. Phone 419 3355. Brisbane L. E. Boughen & Co. Phone 369 1277; Colourview Wholesale Pty. Ltd. Phone 275 3188. Adelaide Protronics Pty. Ltd. Phone 212 3111; D. C. Electroics Pty. Ltd. Phone 223 6946. Perth Simon Holman & Co. Pty. Ltd. Phone 381 4155; Protronics Pty. Ltd. Phone 362 1044.

A cut out and keep Resistor colour coding chart from Crusader Electronics

Get all of Yamaha's latest audio equipment for only 33 cents.



Fill in this coupon and you'll get Yamaha's free catalogue featuring the latest and complete range of compact disc players, cassette decks, turntables, cartridges, integrated amps, separate amps, tuners, receivers, graphic equalizers, headphones and system components. With each component comes something you wouldn't expect. **5 YEAR WARRANTY.**

Name _____

Address _____

Postcode _____

Yamaha Consumer Electronics Division, 17-33
Market Street, South Melbourne, Victoria 3205.

*Limited warranty