



GLIDESCOPE SYSTEM AVL SINGLE-USE

Operations & Maintenance Manual

GLIDESCOPE SYSTEM AVL SINGLE-USE

Operations & Maintenance Manual

Effective: February 15, 2021

Caution: Federal (United States) law restricts this device to sale by or on the order of a physician.

For customers with GlideScope systems using the GlideScope Video Monitor (version 0570-0338).

CONTACT INFORMATION

To obtain additional information regarding your GlideScope system, please contact Verathon Customer Care or visit verathon.com/global-support.

Verathon Inc.

20001 North Creek Parkway
Bothell, WA 98011 U.S.A.
Tel: +1 800 331 2313 (US and Canada only)
Tel: +1 425 867 1348
Fax: +1 425 883 2896
verathon.com



Verathon Medical (Europe) B.V.

Willem Fenengastraat 13
1096 BL Amsterdam
The Netherlands
Tel: +31 (0) 20 210 30 91
Fax: +31 (0) 20 210 30 92



Verathon Medical (Canada) ULC

2227 Douglas Road
Burnaby, BC V5C 5A9
Canada
Tel: +1 604 439 3009
Fax: +1 604 439 3039

Verathon Medical (Australia) Pty Limited

Unit 9, 39 Herbert Street
St Leonards NSW 2065
Australia
Within Australia: 1800 613 603 Tel / 1800 657 970 Fax
International: +61 2 9431 2000 Tel / +61 2 9475 1201 Fax



Copyright © 2021 by Verathon Inc. All rights reserved. No part of this manual may be copied or transmitted by any method without the express written consent of Verathon Inc.

GlideRite, GlideScope, the GlideScope symbol, GVL, Reveal, Verathon, and the Verathon Torch symbol are trademarks of Verathon Inc. All other brand and product names are trademarks or registered trademarks of their respective owners.

Not all Verathon Inc. products shown or described in this manual are available for commercial sale in all countries.

Information in this manual may change at any time without notice. For the most up-to-date information, see the documentation available at verathon.com/product-documentation.

TABLE OF CONTENTS

- IMPORTANT INFORMATION..... 1**
 - Product Information..... 1
 - Statement of Intended Use..... 1
 - Essential Performance 1
 - Environments of Intended Use..... 1
 - Statement of Prescription 1
 - Notice to All Users 1
 - Warnings & Cautions 2
 - Product Description 6

- INTRODUCTION 8**
 - System Parts & Accessories 8
 - Language Settings 11
 - Video Laryngoscope Components..... 12
 - Buttons, Icons, & Connections 13

- SETTING UP..... 16**
 - Procedure 1. Perform Initial Inspection 16*
 - Procedure 2. Mount the GlideScope Video Monitor (Optional)..... 17*
 - Procedure 3. Attach the Video Baton Cradle (Optional)..... 20*
 - Procedure 4. Charge the Monitor Battery 21*
 - Procedure 5. Connect the Video Cable or Smart Cable to the Monitor..... 22*
 - Procedure 6. Connect the Smart Cable to the Video Baton (Video Baton 2.0 Only)..... 23*
 - Procedure 7. Connect to an External Monitor (Optional)..... 24*
 - Procedure 8. Configure User Settings 25*
 - Procedure 9. Perform a Functional Check 26*

USING THE DEVICE28

- Procedure 1. Connect the Video Cable to the Monitor..... 29*
- Procedure 2. Insert the Video Baton into the Stat..... 30*
- Procedure 3. Prepare the GlideScope System..... 30*
- Procedure 4. Intubate Using a Video Baton and Stat..... 31*
- Procedure 5. Use the Record & Snapshot Features (Optional)..... 32*
- Procedure 6. Use the Playback Feature (Optional)..... 34*
- Tips for Using the GlideScope AVL System..... 35
- Tips for Working with Endotracheal Tubes..... 35

REPROCESSING36

MAINTENANCE & SAFETY37

- Periodic Inspections 37
- GlideScope Video Monitor Battery 37
- System Software..... 37
- Device Repair..... 38
- Device Disposal..... 38

WARRANTY.....39

PRODUCT SPECIFICATIONS..... 41

- Component Specifications 41
- Battery Specifications..... 49
- Electromagnetic Compatibility..... 50
- Accessory Conformance to Standards..... 52

GLOSSARY53

IMPORTANT INFORMATION

PRODUCT INFORMATION

The GlideScope AVL Single-Use video laryngoscope system is designed for “1st Pass Success.” It provides a consistently clear view of a patient’s airway, enabling quick intubations. The AVL design is based on the GlideScope GVL, which is clinically proven to achieve a Cormack-Lehane Grade I or II view 99 percent of the time.

STATEMENT OF INTENDED USE

The GlideScope AVL system is intended for use by qualified professionals to obtain a clear, unobstructed view of the airway and vocal cords for medical procedures.

ESSENTIAL PERFORMANCE

Essential performance is the system performance necessary to achieve freedom from unacceptable risk. The essential performance of the GlideScope AVL system is to provide a clear view of the vocal cords.

ENVIRONMENTS OF INTENDED USE

The GlideScope AVL system is intended to be used in professional healthcare environments such as hospitals.

STATEMENT OF PRESCRIPTION

Caution: Federal (United States) law restricts this device to sale by or on the order of a physician.

This system should be used only by individuals who have been trained and authorized by a physician or used by healthcare providers who have been trained and authorized by the institution providing patient care.

NOTICE TO ALL USERS

Verathon recommends that all users read this manual before using the system. Failure to do so may result in injury to the patient, may compromise the performance of the system, and may void the system warranty.

Verathon recommends that new GlideScope users:

- Obtain instruction from a qualified individual
- Practice using the system on a mannequin before clinical use
- Acquire clinical experience on patients without airway abnormalities

WARNINGS & CAUTIONS

Warnings indicate that injury, death, or other serious adverse reactions may result from use or misuse of the device. *Cautions* indicate that use or misuse of the device may cause a problem, such as a malfunction, failure, or damage to the product. Throughout the manual, pay attention to sections labeled *Important*, as these contain reminders or summaries of the following cautions as they apply to a specific component or use situation. Please heed the following warnings and cautions.

WARNINGS



WARNING

Several areas of the Stat that contact the patient can exceed 41°C (106°F) as part of normal operation:

- The first area is the light-emitting area surrounding the camera. When used as indicated, continuous contact with this area is unlikely because, if tissue were to contact this area, the view would be lost and devices would need to be adjusted to regain the airway view.
- The second area is the area surrounding the camera, out of view of the camera. Continuous contact with this area is unlikely because the product is typically not held stationary for an extended period of time exceeding 1 minute.

If continuous contact is maintained for longer than 1 minute, it is possible to cause thermal damage such as a burn to the mucosal tissue.



WARNING

When you are guiding the endotracheal tube to the distal tip of the video laryngoscope, ensure that you are looking in the patient's mouth, not at the screen. Failure to do so may result in injury, such as to the tonsils or soft palate.



WARNING

Before every use, ensure that the instrument is operating correctly and has no sign of damage. Do not use this product if the device appears damaged. Refer servicing to qualified personnel.

Always ensure that alternative airway management methods and equipment are readily available.

Report any suspected defects to Verathon Customer Care. For contact information, visit verathon.com/global-support.



WARNING

Because the product may be contaminated with human blood or body fluids capable of transmitting pathogens, all cleaning facilities must be in compliance with (U.S.) OSHA Standard 29 CFR 1910.1030 "Bloodborne Pathogens" or an equivalent standard.



WARNING

This product may only be cleaned, disinfected, or sterilized by using the approved processes provided in the GlideScope and GlideRite Products Reprocessing Manual (part number 0900-5032). Cleaning, disinfection, and sterilization methods listed are recommended by Verathon based on efficacy or compatibility with component materials.



WARNING

To maintain electrical safety, use only the provided power supply. Connect the power cord and power adapter to a properly grounded plug, and ensure that the disconnect is easily accessible. Use only the accessories and peripherals recommended by Verathon.



WARNING

To reduce the risk of electrical shock, use only the accessories and peripherals recommended by Verathon.



WARNING

Electric shock hazard. Do not attempt to open the system components. This may cause serious injury to the operator or damage to the instrument and voids the warranty. Contact Verathon Customer Care for all servicing needs.



WARNING

No modification of this equipment is allowed.



WARNING

The external monitor must be safety-approved medical equipment.



WARNING

Use only a passive-type USB flash drive. Do not use USB drives powered by another external source.



WARNING

Electric shock hazard. Do not immerse the power adapter in water. When cleaning the power adapter, use a cloth dampened with isopropyl alcohol on the outside of the enclosure.



WARNING

Verathon has conducted no analysis to establish the compatibility of the system with environments where magnetic resonance imaging (MRI) equipment is installed. Because of this, the owner of the system must exclude it from any magnetic resonance (MR) environment.



WARNING

Do not use the power adapter in the presence of flammable anesthetics.



WARNING

Do not reuse, reprocess, or resterilize single-use components. Reuse, reprocessing, or resterilization may create a risk of contamination of the device.



WARNING

Use of accessories and cables other than those specified or provided by Verathon may cause this system to experience electromagnetic malfunctions, including increased emissions or decreased immunity. This may cause improper operation, procedure delays, or both.



WARNING

Portable radio frequency communications equipment (including peripherals such as antenna cables and external antennas) may not be used within 30 cm (12 inches) of any part of the GlideScope system, including cables that Verathon specifies or provides for use with the system. If this distance is not maintained, performance of the system may be degraded and image display may be compromised.

CAUTIONS



CAUTION

Medical electrical equipment requires special precautions regarding electromagnetic compatibility (EMC) and must be installed and operated according to the instructions in this manual. For more information, see the Electromagnetic Compatibility section.

Avoid using the GlideScope system adjacent to or stacked with other equipment. If adjacent or stacked use is necessary, observe the system to verify normal operation in the configuration in which it will be used.

This device can radiate radio frequency energy and is highly unlikely to cause harmful interference with other devices in the vicinity. There is no guarantee that interference will not occur in a particular installation. Evidence of interference may include degradation of performance in this device or other devices when operated simultaneously. If this occurs, try to correct the interference by using the following measures:

- Turn devices on and off in the vicinity to determine the source of interference
- Reorient or relocate this device or other devices
- Increase the separation between devices
- Connect the device to an outlet on a circuit different than the other device(s)
- Eliminate or reduce EMI with technical solutions (such as shielding)
- Purchase medical devices that comply with IEC 60601-1-2 EMC standards

Be aware that portable and mobile radio frequency communications equipment (cellular phones, etc.) may affect medical electrical equipment; take appropriate precautions during operation.

PRODUCT DESCRIPTION

The GlideScope AVL system is an ideal tool for physicians and other healthcare professionals who need to effectively manage routine to difficult airways. It is useful for the intubation of normal airways, anterior airways, neonatal patients, obese patients, and patients with limited neck extension. Additionally, it is useful for teaching purposes, verification of endotracheal tube (ETT) placement, nasal intubation, and ETT exchange. The AVL is easy to learn, use, and teach. It is ideal for acute care settings and emergency environments. It also integrates into standard ED, OR, ICU, and NICU applications.

The system combines a high-resolution, full-color digital camera with an integrated LED light source and Reveal anti-fog feature. The video batons connect directly to a full-color, digital video monitor for real-time viewing.

The system is recommended for use with an endotracheal tube stylet such as the GlideRite Rigid Stylet or GlideRite Single-Use Stylets, which complements the blade angle.

GLIDESCOPE VIDEO MONITOR

The monitor can record video and photos directly to a USB flash drive for archiving and further review. The monitor has a DVI video output through an HDMI connector. It is recommended that you use the HDMI-to-DVI cable provided by Verathon to connect to an external monitor that is approved for medical use. You can operate the monitor by connecting it to the medical-grade power supply provided by Verathon or by using the internal, rechargeable lithium-ion battery.

Verathon occasionally makes software updates available for the GlideScope video monitor. This manual documents the most current version of the GlideScope Video Monitor software. If your monitor does not function as described in this manual, or to determine if your software should be updated, contact Verathon Customer Care.

Figure 1. *GlideScope Video Monitor*



SINGLE-USE SYSTEM

The AVL single-use system can be used with a choice of three video batons and multiple GVL Stats. Single-use GVL Stats are offered in a comprehensive range of sizes, allowing clinicians to meet the particular requirements of patients of various sizes.

The system may include the following components:

- GlideScope Video Monitor
- AVL Video Baton 1–2
 - GVL 0 Stat
 - GVL 1 Stat
 - GVL 2 Stat
 - GVL 2.5 Stat
- Video Baton 2.0 Large (3–4) or AVL Video Baton 3–4
 - GVL 3 Stat
 - GVL 4 Stat
- GlideRite Single-Use Stylet (Small; recommended for use with the AVL Video Baton 1–2)
- GlideRite Single-Use Stylet (Medium; recommended for use with the Video Baton 2.0 Large (3–4) or AVL Video Baton 3–4)
- GlideRite Single-Use Stylet (Large) or GlideRite Rigid Stylet (recommended for use with the Video Baton 2.0 Large (3–4) or AVL Video Baton 3–4)

Note: Video Batons 2.0 require GlideScope Video Monitor software version 3.9 or later. For more information, refer to [System Software](#) on [page 37](#).

Figure 2. GlideScope AVL Single-Use System



INTRODUCTION

SYSTEM PARTS & ACCESSORIES

The system consists of the following components.

Table 1. System Components

PARTS & ACCESSORIES	
Required Components	
<p>GlideScope Video Monitor</p> 	<p>Video batons</p> 
<p>GVL Stat sizes 0, 1, 2, 2.5, 3, and 4 (single-use)</p> 	

PARTS & ACCESSORIES

Smart Cable
(for Video Baton 2.0)

*Note: Cable shortened for
illustration purposes.*



Video monitor 12 V DC
power adapter



Power cable



In-service USB flash drive

Note: Contains instructions for use.



PARTS & ACCESSORIES

Optional Components

Premium cart



Mobile stand



Universal accessory basket

Note: For use with AVL portable stand



Media storage USB flash drive



Cradle for video baton



IV pole mounting kit



HDMI-to-DVI cable



PARTS & ACCESSORIES

GlideRite DLT Stylet
Note: For ET tubes 6.0 mm or larger

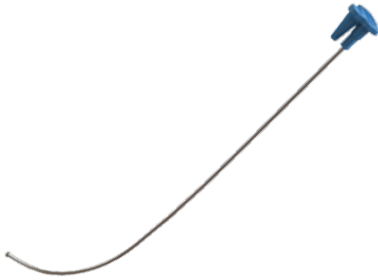

GlideRite Rigid Stylet
Note: For ET tubes 6.0 mm or larger



GlideRite Single-Use Stylet (Small)
Note: For ET tubes 3.0–4.0 mm



GlideRite Single-Use Stylet (Medium)
Note: For ET tubes 4.5–5.5 mm



GlideRite Single-Use Stylet (Large)
Note: For ET tubes 6.0 mm or larger



LANGUAGE SETTINGS

The GlideScope Video Monitor software is available in a variety of languages. To change the language used on your system, you must install a new software version via a USB flash drive. For more information, contact Verathon Customer Care or your local representative. For contact information, visit verathon.com/global-support.

VIDEO LARYNGOSCOPE COMPONENTS

The following diagram shows the individual parts of an AVL video laryngoscope (a reusable video baton with a single-use Stat).

Figure 3. AVL Video Laryngoscope Components

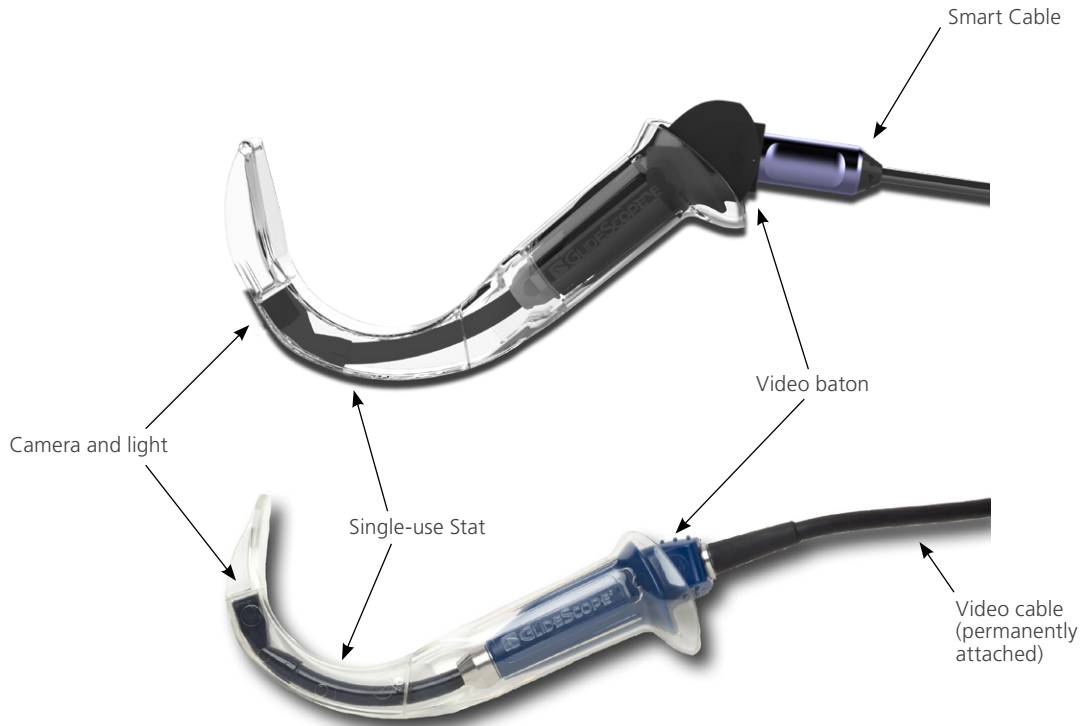

BUTTONS, ICONS, & CONNECTIONS

The main component of the system is the digital, full-color monitor. The front of the monitor includes the screen and the buttons you use to operate the system.

The back panel of the monitor includes the sockets and ports for connecting the power cord, the video cable, an HDMI-to-DVI cable for external video display, and a USB flash drive. When a socket or port is not in use, it is recommended that the rubber cap is inserted into the opening. This protects the exposed connectors from dust and other contamination. The back of the video monitor also features a mounting plate fitting that allows you to attach the monitor to a mobile stand or IV pole.

Figure 4. GlideScope Video Monitor Keypad

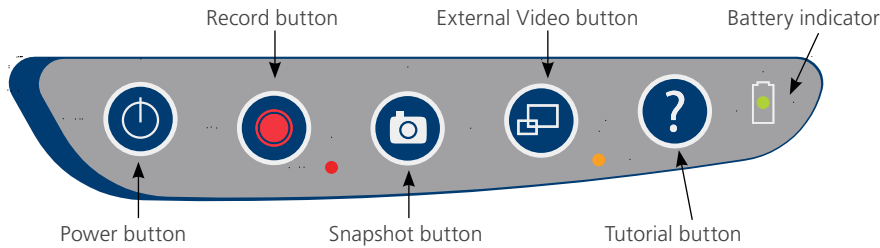

Table 2. Keypad Buttons



















BUTTON	FUNCTION
	Power: Press and release to turn on the monitor. Press and hold to turn it off. <i>Note: If the monitor freezes at any time during use, press and hold the Power button for 10 seconds to reset the system.</i>
	Record: Press to start and stop recording directly to a USB flash drive that has been inserted in the USB port. When you are recording, the red LED indicator to the right of the button will be lit, and the Recording icon  will be shown on the screen. <i>Note: To record video, a USB flash drive must be inserted into the monitor USB port.</i>
	Snapshot: Press this button to save a snapshot of the live display to the USB flash drive. You may take a snapshot while video recording or independent of recording. <i>Note: To take a snapshot, a USB flash drive must be inserted into the monitor USB port.</i>
	External Video: Press to display video on an external monitor. The yellow LED to the right of the button will light up to indicate that the feature has been activated. Press the button again to deactivate the external video. <i>Note: An HDMI-to-DVI cable is required in order to display video on an external monitor.</i>
	Tutorial: If a USB flash drive is not inserted into the monitor, press and hold to access the video tutorial. If a USB flash drive is inserted into the monitor, press and hold to access the Playback menu. <i>Note: The Playback menu is only accessible if the GlideScope Video Monitor is operating software version 3.4 or higher and if a USB flash drive is inserted in the monitor.</i>
	Battery Indicator: LED is: Green: Unit fully charged Red: Unit charging Flashing Red: Indicates a problem with the battery. Charge for 6 hours, and if still flashing, contact Verathon Customer Care.

Table 3. On-Screen Icons

ICON	FUNCTION
	<p>Battery Status: The remaining battery power is indicated by the Battery Status icon and the percentage above the icon. If the icon is red, the battery should be charged as soon as possible. (See Charge the Monitor Battery.) While the battery is being charged, a lightning bolt will be displayed alongside the Battery Status icon.</p>
	<p>Progress Confirmation: While the user is pressing a button, the operation is loading. If the button is released before the loading process is completed, the operation is canceled.</p>
	<p>Power-Down Countdown: The unit is about to turn off. If this is due to the Auto Power Off feature that saves battery life, pressing any button stops the power-down sequence.</p> <p><i>Note: The Auto Power Off feature can be adjusted or disabled on the User Settings screen. For more info, see Configure User Settings on page 25.</i></p>
	<p>USB Flash Drive: A USB flash drive is detected.</p> <p>While recording, a number next to the icon indicates approximately what percentage of the USB flash drive has been used. When the USB flash drive is full, recording stops.</p>
	<p>Incompatible USB Drive: The USB flash drive that is plugged into the monitor is not suitable for recording videos. (This normally occurs when using an older, inexpensive USB flash drive that is not capable of the speed necessary to save video in real time.)</p>
	<p>USB Flash Drive Not Found: A USB drive needs to be inserted into the USB port.</p>
	<p>Attach Video Cable: The video baton or video laryngoscope is not attached to the monitor.</p>
	<p>Recording: The system is recording video to the USB flash drive.</p> <p><i>Note: Do not remove the USB flash drive while recording is in progress, or the recording will be lost.</i></p>
	<p>Saving Snapshot: The system is saving a snapshot to USB flash drive.</p> <p><i>Note: Do not remove the USB flash drive while saving a snapshot, or the snapshot will be lost.</i></p>
	<p>Saving File: The system is saving a recorded file to the USB flash drive.</p> <p><i>Note: Do not remove the USB flash drive while this icon is displayed, or the recording will be lost.</i></p>
	<p>External Monitor: The HDMI-to-DVI connection for external video is enabled. Video may now be displayed on an external monitor.</p>









ICON	FUNCTION
	Hourglass: Please wait while the system prepares for the next action.
	Audio Recording is Active: Audio is being recorded on the video. <i>Note: The default for audio recording is OFF, so audio recording on the video occurs only if the default has been changed to ON in user settings.</i>
	Back Arrow: Exit to previous screen.
	Up Arrow: Select previous file for playback.
	Down Arrow: Select next file for playback.
	Play: Play the selected file or continue playing a paused video file.
	Pause: Pause the video playback.
	Snapshot: On the Playback menu, this icon indicates that a file is a snapshot.
	Video: On the Playback menu, this icon indicates that a file is a video.

Figure 5. GlideScope Video Monitor Back Panel



SETTING UP

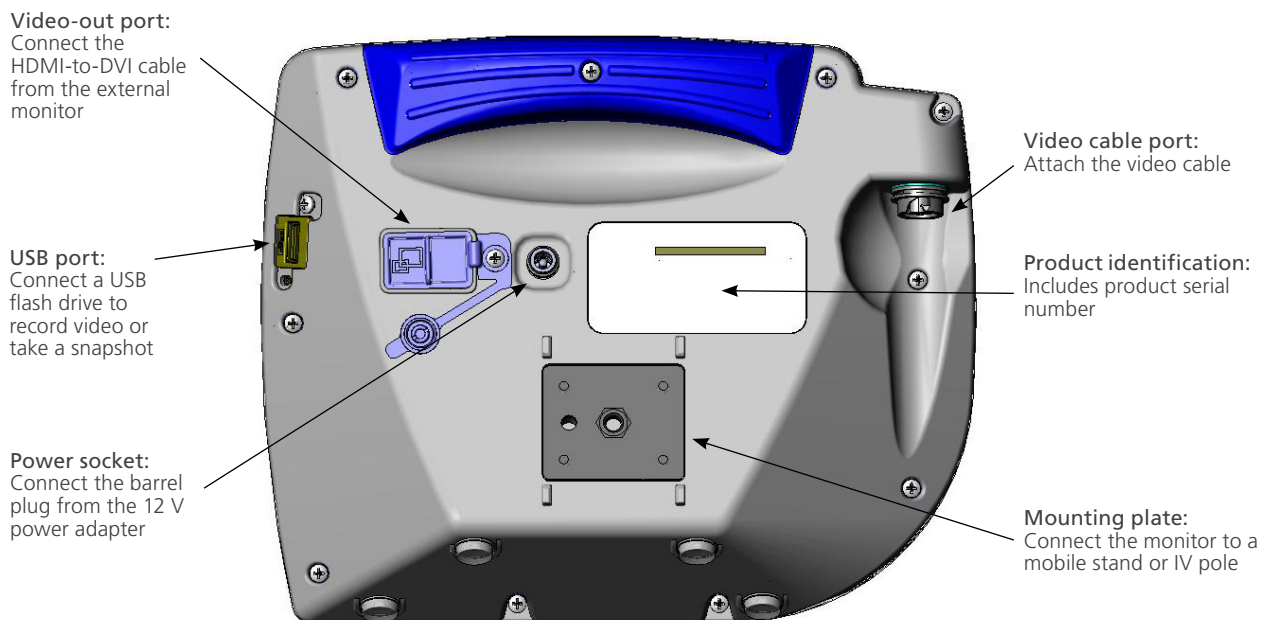

Please read the [Warnings & Cautions](#) section before performing the following tasks.

Before you can use the system for the first time, you must inspect the components, set up the system, and perform a functional test as recommended by Verathon. Complete the following procedures:

1. **Perform Initial Inspection**—Inspect the system for any obvious physical damage that may have occurred during shipment.
2. **Mount the GlideScope Video Monitor (Optional)**—Set up the GlideScope Video Monitor on a mobile stand or IV pole.
3. **Charge the Monitor Battery**—You can use the system while the battery is charging.

Note: The monitor will operate without charging the battery by using the GlideScope Video Monitor 12 V DC Power Adapter that shipped with the unit.

4. **Connect the Video Cable or Smart Cable to the Monitor**—Attach the cable that connects the video baton or laryngoscope to the monitor and transmits the video data.
5. **Connect the Smart Cable to the Video Baton (Video Baton 2.0 Only)**—Attach the Smart Cable to a GlideScope Video Baton 2.0.
6. **Connect to an External Monitor (Optional)**—Connect the monitor to an external display source, such as a larger monitor screen, by using the HDMI-to-DVI cable.
7. **Configure User Settings**—Enter data customized to your clinic, and configure settings such as the date and time.
8. **Perform a Functional Check**—Before you use the device for the first time, perform a functional check to ensure that the system is working properly.

PROCEDURE 1. PERFORM INITIAL INSPECTION

When you receive the system, Verathon recommends that an operator familiar with the instrument perform a full visual inspection of the system for any obvious physical damage that may have occurred during shipment.

1. Verify that you have received the appropriate components for your system by referring to the packing list included with the system.
2. Inspect the components for damage.
3. If any of the components are missing or damaged, notify the carrier and Verathon Customer Care or your local representative. For contact information, visit verathon.com/global-support.

PROCEDURE 2. MOUNT THE GLIDESCOPE VIDEO MONITOR (OPTIONAL)

If you choose to mount the system, you may use either of the following configurations:

- Mount it on a premium cart or mobile stand (Figure 6 or Figure 7). These solutions make it easy for you to move the system from one location to another.
- Mount it on an IV pole (Figure 8).

This procedure includes instructions for assembling the mobile stand, mounting the system on either the mobile stand or an IV pole, and adjusting the monitor angle.

Figure 6. Premium Cart



Figure 7. Mobile Stand

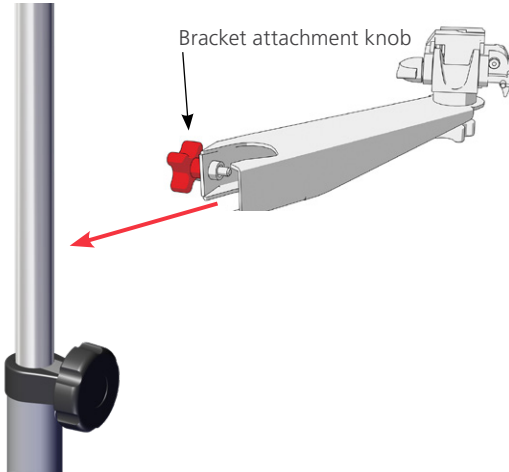

Figure 8. IV Pole Mount



ATTACH THE MONITOR TO THE MOBILE STAND OR IV POLE

1. If you are using the GlideScope premium cart or AVL portable stand, assemble it according to the instructions included with the component.
2. If you are using an IV pole mount, place the mounting bracket on the IV pole, and then tighten the bracket attachment knob until the IV pole mount is secure.



3. On the mobile stand mount or the IV pole mount, ensure that the locking pin and quick-release lever are in the unlocked (horizontal) position.

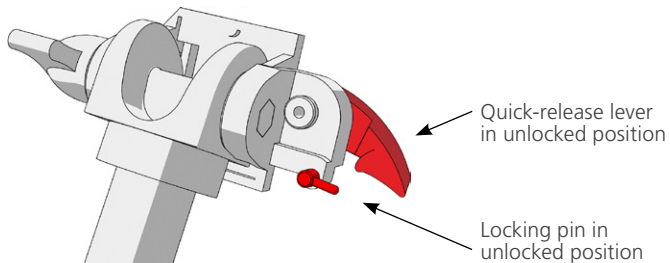

4. While holding the quick-release locking plate with the head of the mounting screw facing away from you and the larger of the two flanges to your left, Insert a positioning pin into the right-hand hole on the locking plate as shown in the following image.

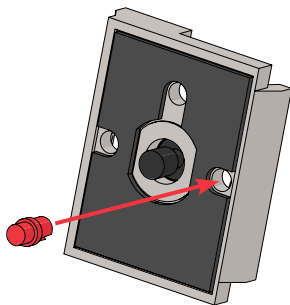

- Using the orientation shown in the following images, screw the quick-release locking plate to the back panel of the monitor.

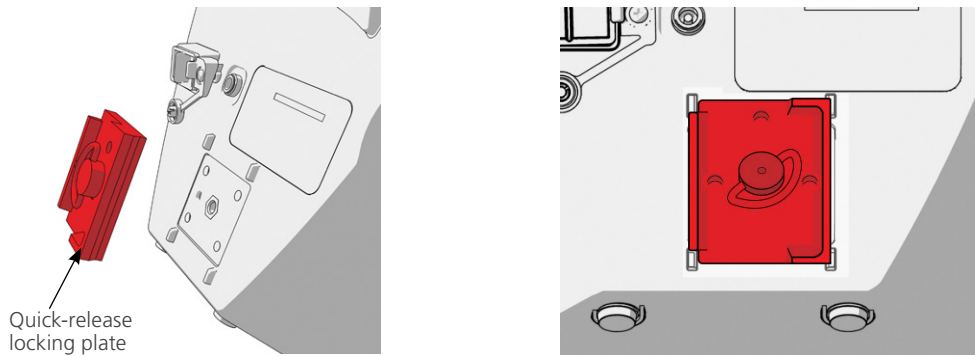

- Seat the locking plate of the monitor on the quick-release mount. When properly situated, the monitor sits securely on the mount, and the quick-release lever automatically snaps into the locked (down) position.
- Ensure that the quick-release lever is fully in the locked (down) position. This locks the monitor into place.

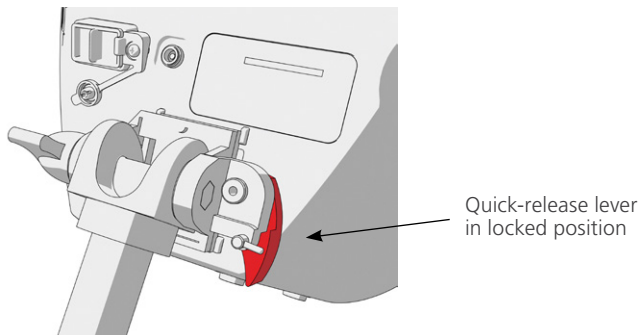

- Adjust the locking pin to the locked (down) position. This secures the quick release lever in the locked position.

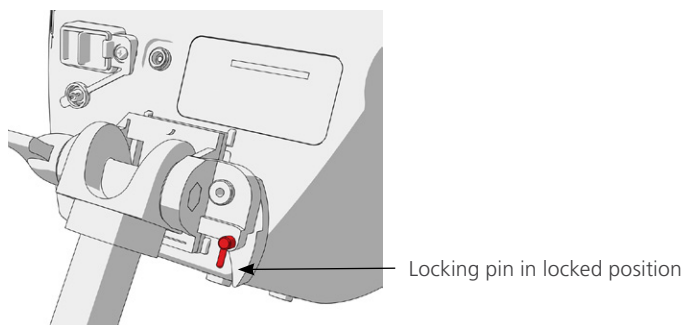

ADJUST THE MONITOR ANGLE

Before you start using the video monitor, adjust the angle of the monitor for optimal viewing. The ideal angle minimizes glare and maximizes visibility.

1. Turn the angle adjustment knob counterclockwise.

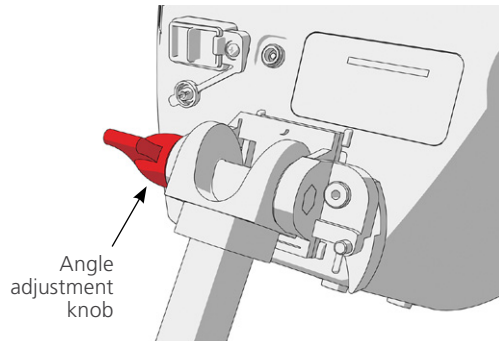

2. Tilt the monitor to the desired angle.
3. Turn the angle adjustment knob clockwise. This secures the monitor at the desired angle.
4. To attach a video baton cradle, see the procedure [Attach the Video Baton Cradle \(Optional\)](#).

PROCEDURE 3. ATTACH THE VIDEO BATON CRADLE (OPTIONAL)

You may elect to attach a video baton cradle to the mobile stand or IV pole mount.

1. Screw the center pole clamp to the video baton cradle.
2. Attach the center pole clamp and video baton cradle to the pole, and then turn the adjustment knob clockwise to tighten.

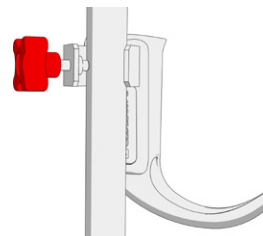
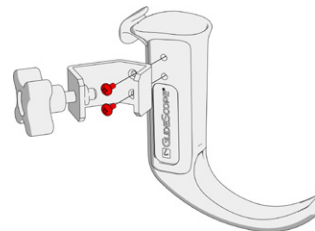

PROCEDURE 4. CHARGE THE MONITOR BATTERY







Please read the [Warnings & Cautions](#) section before performing the following task.

The GlideScope Video Monitor includes an internal lithium-ion battery. Verathon recommends that you charge the battery fully prior to first use.

Under normal operating conditions, a fully charged battery lasts approximately 90 minutes or longer before it needs to be recharged. For optimal battery life, ensure that the battery is fully charged before you try to use the monitor in battery mode. You should charge the battery at temperatures between 0–35°C (32–95°F).

The percentage above the Battery Status icon indicates the remaining battery charge.

Figure 9. Battery Status Icons

-  19% battery life or less remaining. Battery must be charged.
-  20% to 50% battery life remaining.
-  51% to 82% battery life remaining.
-  Battery is 83% to fully charged. The lightning bolt indicates that the battery is charging.

1. Connect the video monitor 12 V DC power adapter to the power cable.
2. On the back panel of the monitor, remove the power socket cap, and then connect the 12 V DC power adapter to the power socket.

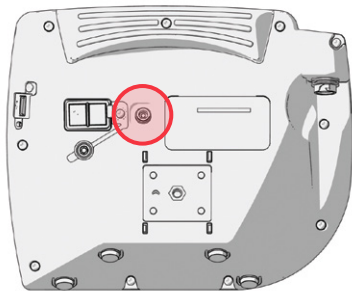

3. Plug the power supply into a hospital-grade power outlet.
4. Allow the battery to charge. Fully charging the battery may take up to 6 hours.

PROCEDURE 5. CONNECT THE VIDEO CABLE OR SMART CABLE TO THE MONITOR

This procedure connects the video cable or Smart Cable to the monitor, which displays the image transmitted from the camera.

Ensure that the video monitor is turned off prior to connecting or disconnecting the video cable or Smart Cable.

1. Align the arrow on the video cable or Smart Cable and the arrow on the video cable port.



2. Insert the cable into the port. You will hear a click when the cable is successfully connected.

Note: When disconnecting the cable from the monitor, rotate the connector ring in the direction of the arrow.

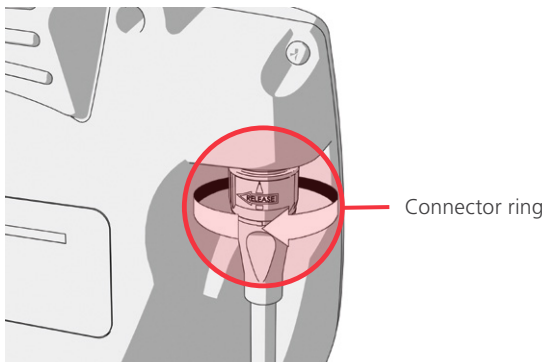

PROCEDURE 6. CONNECT THE SMART CABLE TO THE VIDEO BATON (VIDEO BATON 2.0 ONLY)

If you want to use GlideScope Video Batons 2.0 with the GlideScope Video Monitor, you can use a Smart Cable to connect them.

Note: Video Batons 2.0 require system software version 3.9 or later. For more information, refer to [System Software](#) on page 37.

1. After connecting the Smart Cable to the monitor as described in the section [Connect the Video Cable or Smart Cable to the Monitor](#) on page 22, grasp the other end of the Smart Cable in one hand.
2. Holding the video baton in the other hand, align the HDMI connectors on the Smart Cable and the baton with one another.
3. Insert the HDMI connector on the Smart Cable into the connector on the video baton.

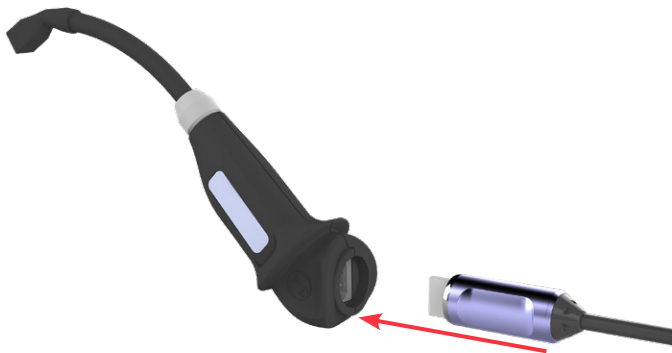

4. Press the Smart Cable securely into place within the recess on the video baton.



PROCEDURE 7. CONNECT TO AN EXTERNAL MONITOR (OPTIONAL)



Please read the [Warnings & Cautions](#) section before performing the following task.



By using an HDMI-to-DVI cable, you can connect the GlideScope Video Monitor to an external monitor that is approved for medical use. For more information, please contact your Verathon Customer Care representative.

Note: Image quality on the external monitor may vary according to the resolution of the external monitor.

Note: To maintain electromagnetic interference (EMI) within certified limits, the system must be used with the cables, components, and accessories specified or supplied by Verathon. For additional information, see the [System Parts & Accessories](#) and [Component Specifications](#) sections. The use of accessories or cables other than those specified or supplied may result in increased emissions or decreased immunity of the system.

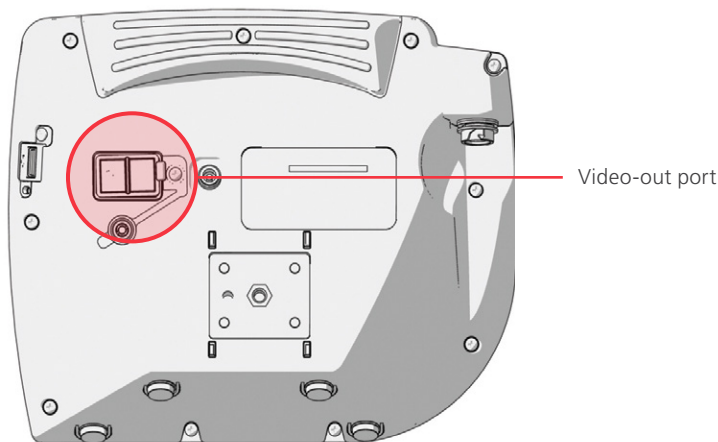
1. Ensure that the video monitor is turned off.
2. On the back of the monitor, remove the HDMI cap from the video-out port.
3. Connect the HDMI end of the cable to the video-out port.



4. Connect the other end of the cable to the DVI port on an external monitor that is approved for medical use.
5. Press the **Power**  button. The monitor turns on.
6. Press the **External Video**  button. The indicator LED to the right of the button illuminates when the connection is successful, and the video displays on the external monitor.
7. To stop sending video to an external monitor, press the **External Video**  button again.
8. Prior to disconnecting the HDMI-to-DVI cable, ensure the video monitor is turned off.

PROCEDURE 8. CONFIGURE USER SETTINGS

You may configure the following settings directly on the unit:

- Date and Time
- Date and Time Format
- Key Click Sound
- Auto Power Off
- Audio Recording
- Auto Recording
- Auto External Video
- Clinic Name

The second page of user settings, as seen in [Figure 11](#), is only available if your GlideScope Video Monitor is running software version 3.4 or higher. This page of user settings displays system use information, and it does not contain any configurable settings. If you would like to update the software, see [System Software](#) on page 37.

Figure 10. User Settings Screen Page 1

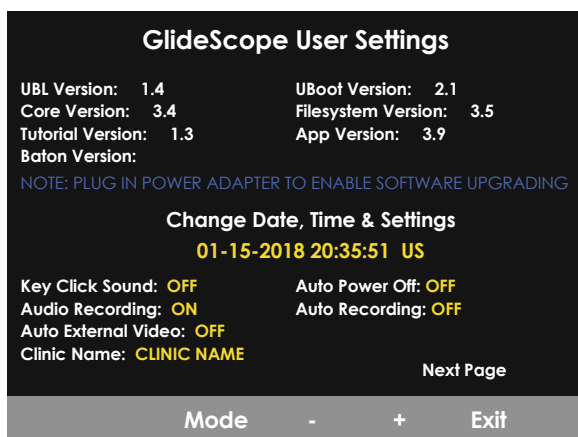
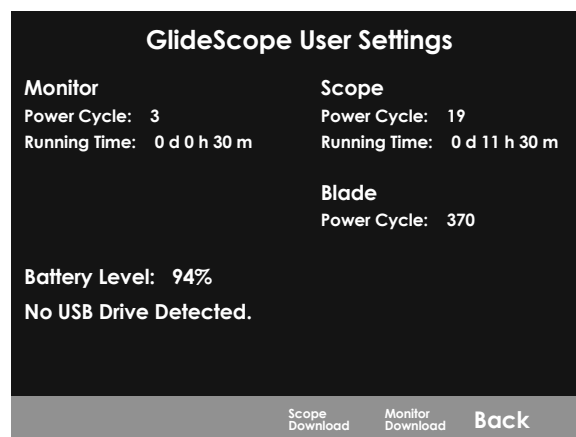















Figure 11. User Settings Screen Page 2



1. If a USB flash drive is inserted into the monitor, remove it.
2. Press the **Power**  button. The monitor turns on.
3. Press and hold the **Tutorial** button , and while continuing to hold it, press the **Snapshot** button . The User Settings screen appears on the monitor. The configurable user settings are displayed in yellow, and the selected setting is highlighted in red.
4. Customize your user settings by using the following buttons:
 - Press the **Record** button  to select the parameter you want to set.
 - Press the **Snapshot** button  to decrease the parameter value.
 - Press the **External Video** button  to increase the parameter value.
 - When inputting the Clinic Name, the **Tutorial** button  moves the selection to the next letter. Press the **Record** button  twice to return the selection back to the Date/Time setting.
 - To view the second page of user settings, press the **Record** button  until **Next Page** is highlighted in red, and then press the **Tutorial** button . To exit the second page of user settings, press the **Tutorial** button  again.
5. When you are finished customizing the settings, press the **Record** button  until the option **Exit** is available in the gray bar, and then press the **Tutorial** button . This saves the parameters, and the User Setting screen closes.

PROCEDURE 9. PERFORM A FUNCTIONAL CHECK

Before you use the device for the first time, perform the following functional check to ensure that the system is working properly. Please contact your local Verathon representative or Verathon Customer Care if your system does not function as described below. For contact information, visit verathon.com/global-support.

REQUIRED CHECKS

1. Fully charge the monitor battery (this takes approximately 6 hours).
2. Connect a video cable or Smart Cable to a video baton, and then connect it to the monitor.
3. Press the **Power**  button. The monitor turns on.
4. Look at the monitor screen, and verify that the image displayed is being received from the video baton.





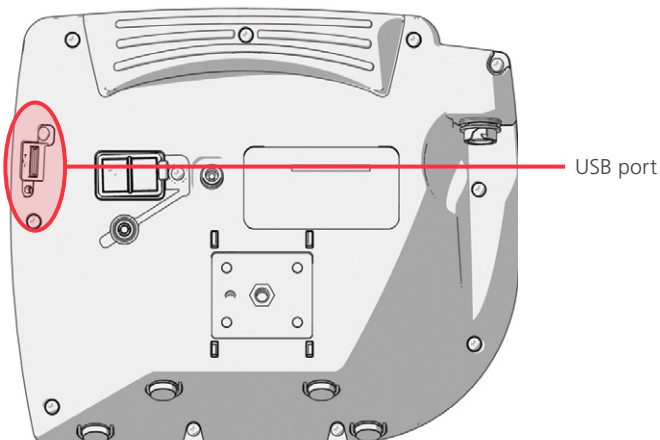

Note: There may be a slight blade intrusion in the upper-left and upper-right corners of the monitor, and a thin line may appear along the top. These blade edges are captured in the view because of the wide-angle camera lens used in the video laryngoscope. This image acts as a frame of reference during the intubation process and ensures that the orientation of the image is correct in the monitor.

RECOMMENDED CHECKS

5. On the back of the monitor, remove the USB port cap, and then insert a USB flash drive into the port.



6. Ensure that the USB flash drive is detected by checking if the **USB Flash Drive** icon  on the bottom of the screen is displayed.
7. Press the **Record** button . Recording starts.

8. To stop recording, press the **Record** button  again.
9. Wait until the **Saving File** icon  has disappeared from the screen, and then remove the USB flash drive from the monitor.
10. On a computer, verify that the recorded video (.avi) file can be played.

Note:

If you are viewing the recorded file on a Windows operating system (OS), use an application such as Windows Media Player.

If you are viewing the recorded video file on Mac OS, use an application such as one of the following:

- MPlayerX (free in the App Store)
- VLC (free at <http://www.videolan.org/vlc/index.html>)

If you are viewing the recorded video file on iOS, use an application such as one of the following:

- VLC for iOS (free in the App Store)
- 8player lite (free in the App Store)
- Media Player—PlayerXtreme HD (free in the App Store)

USING THE DEVICE

Prior to using the device, set up the device according to the instructions in the previous chapter, and verify the setup by completing the procedure [Perform a Functional Check](#).



Please read the [Warnings & Cautions](#) section before performing the following tasks.

AVL video laryngoscopes are equipped with the Reveal anti-fog feature, which reduces camera fogging during the intubation procedure. To fully optimize the feature, you must allow the video laryngoscope to warm up for 30-120 seconds prior to use, depending on the ambient temperature and humidity of the clinical environment. Full optimization of the anti-fog feature is not necessary in order to use the device; if desired, you may begin the intubation procedure immediately.

Note: If the video laryngoscope is stored in cold conditions, additional warming time may be required for optimal performance of the anti-fog feature.

Using the system consists of the following procedures:

- [Connect the Video Cable or Smart Cable to the Monitor](#)
- [Insert the Video Baton into the Stat](#)
- [Prepare the GlideScope System](#)
- [Intubate Using a Video Baton and Stat](#)
- [Use the Record & Snapshot Features \(Optional\)](#)
- [Use the Playback Feature \(Optional\)](#)

PROCEDURE 1. CONNECT THE VIDEO CABLE TO THE MONITOR

Ensure that the video monitor is turned off prior to connecting or disconnecting the video cable.

1. Ensure the video laryngoscope and other system components have been properly cleaned and disinfected. For more information, refer to the *GlideScope and GlideRite Products Reprocessing Manual* (part number 0900-5032).
2. Based on a clinical assessment of the patient and the experience and judgment of the clinician, select the video baton/Stat combination that is appropriate for the patient.
3. Align the arrow on the video cable and the arrow on the video cable port.



4. Insert the video cable into the port. You will hear a click when the cable is successfully connected.

Note: When disconnecting the video cable from the monitor, rotate the connector ring in the direction of the arrow.

PROCEDURE 2. INSERT THE VIDEO BATON INTO THE STAT

1. Open the GVL Stat pouch, but do not remove the Stat from the packaging.
2. Ensure that the logo on the side of the baton and the logo on the side of the Stat are aligned.
3. Slide the video baton into the GVL Stat until it clicks into place. Do not remove the Stat from the pouch until you are ready to begin the intubation. This ensures that the Stat remains as clean as possible.

Note: Ensure that you do not insert the video baton backwards.

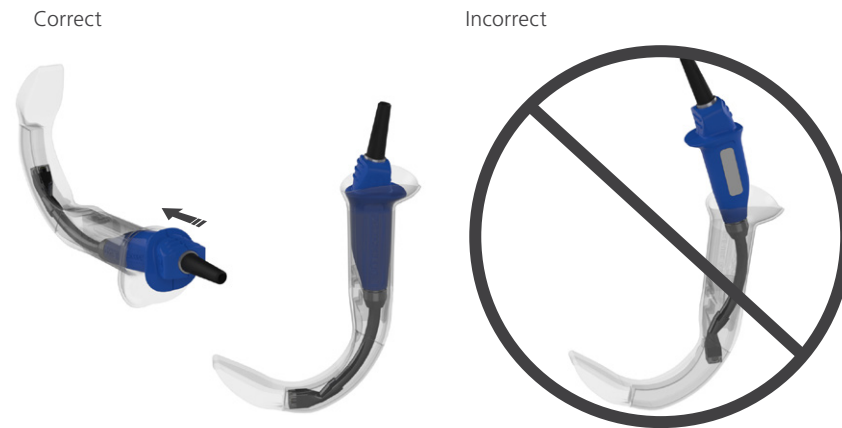

4. When you remove the GVL Stat from the packaging, visually inspect the Stat to ensure that all exterior surfaces are free of unintended rough areas, sharp edges, protrusions, or cracks.

PROCEDURE 3. PREPARE THE GLIDESCOPE SYSTEM

1. Press the **Power** button . The video monitor turns on.

Note: If the monitor locks up or becomes unresponsive for any reason, press and hold the Power button for 10 seconds to reboot the system.

2. Ensure that the battery is sufficiently charged. If necessary, connect the monitor directly to power.
3. On the monitor screen, verify that the image displayed is from the video laryngoscope camera. On the monitor, a small portion of the GVL Stat may be visible on the top or upper-left and right corners.
4. If needed, allow the GlideScope Reveal anti-fog feature to warm up for 30–120 seconds.

Note: The time required for the anti-fog feature to be fully optimized varies according to the ambient temperature and humidity where the equipment is being stored or used. If the video laryngoscope is stored in cold conditions, additional warming time may be required for optimal performance of the anti-fog feature.

5. If desired to provide additional anti-fog benefits, you may apply Dexide Fred Lite to the camera window on the Stat.* Use the solution according to the manufacturer's instructions.

* Compatibility has been demonstrated for up to one hour of continuous exposure on video batons and Stats.

PROCEDURE 4. INTUBATE USING A VIDEO BATON AND STAT



Please read the [Warnings & Cautions](#) section before performing the following task.

To perform an intubation, Verathon recommends using the technique outlined in this procedure. Prior to beginning this procedure, verify that the monitor is receiving an accurate image from the video laryngoscope.

1. Stabilize the patient's head.
2. Look in the mouth, insert the blade midline, and then advance the tip into the vallecula.
3. Look at the screen, and then lift the epiglottis for a view of the larynx.
4. Look in the mouth, and then introduce an endotracheal tube alongside the blade.
5. Look at the screen, and then complete the intubation.
6. If using a GlideRite stylet, remove it by pulling toward the patient's feet.

PROCEDURE 5. USE THE RECORD & SNAPSHOT FEATURES (OPTIONAL)



Please read the [Warnings & Cautions](#) section before performing the following tasks.

The system is equipped with video and audio recording features and the ability to save a snapshot of the live display on the monitor. The video monitor saves this data to a USB flash drive, and you can view the recordings or snapshots on a computer or on the video monitor. For more information about viewing these files on a monitor, see [Use the Playback Feature \(Optional\)](#) on page 34.



By default, audio recording is disabled on the system. If you would like the system to record audio in addition to video, complete the procedure [Configure User Settings](#) in order to enter the User Setting display, and then change the **Audio Recording** setting to **On**.

While recording, a number next to the icon indicates approximately what percentage of the USB flash drive has been used. When the USB flash drive is full, recording stops.

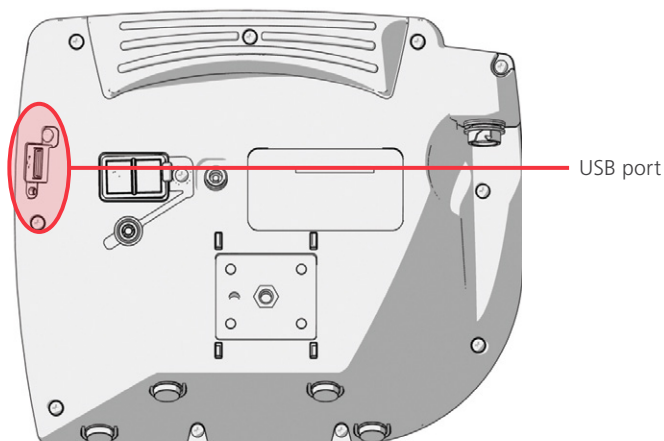

1. On the back of the monitor, remove the USB port cap, and then insert a USB flash drive into the port.

Note: If you do not insert a USB flash drive, the video recording, audio recording, and snapshot features will not be available.





2. Ensure that the USB flash drive is detected by checking if the **USB Flash Drive** icon  on the bottom of the screen is displayed.
3. If you are recording the intubation, press the **Record** button . Video recording starts and is saved to the USB flash drive.

If audio recording is enabled in the User Settings display, the **Audio Recording is Active** icon  will appear on the screen, and audio will be recorded with the video.

4. When you are finished recording, press the **Record** button  again, and then wait for the **Saving File** icon  to disappear.

Note: If you remove the USB flash drive before the Saving File icon disappears, the recording will be lost.

5. If at any point you would like to save a photo of the live display to the USB flash drive, press the **Snapshot** button , and then wait for the **Saving Snapshot** icon  to disappear.

Note: If you remove the USB flash drive before the Saving Snapshot icon disappears, the photo will be lost.

6. If you would like to review the recorded files on the video monitor, complete the following procedure, [Use the Playback Feature \(Optional\)](#).

If you would like to review the recorded files on a computer, insert the USB flash drive into the PC, and then view the .avi or .jpg files.

Note:

If you are viewing the recorded file on a Windows operating system (OS), use an application such as Windows Media Player.

If you are viewing the recorded video file on Mac OS, use an application such as one of the following:

- *MPlayerX (free in the App Store)*
- *VLC (free at <http://www.videolan.org/vlc/index.html>)*

If you are viewing the recorded video file on iOS, use an application such as one of the following:

- *VLC for iOS (free in the App Store)*
- *8player lite (free in the App Store)*
- *Media Player—PlayerXtreme HD (free in the App Store)*

PROCEDURE 6. USE THE PLAYBACK FEATURE (OPTIONAL)

Recorded videos and snapshots on a USB flash drive can be viewed on the GlideScope Video Monitor.

This feature is only available if your GlideScope Video Monitor is running software version 3.4 or higher. For more information about upgrading the software, see [System Software](#) on page 37.









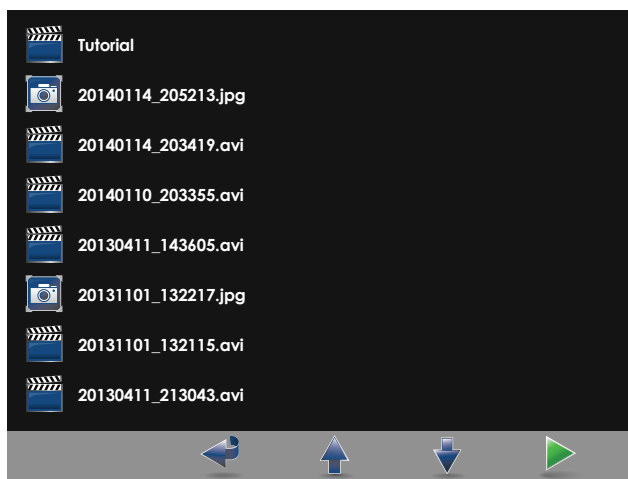

1. On the back of the monitor, remove the USB port cap, and then insert a USB flash drive into the port.
2. Ensure that the USB flash drive is detected by checking if the **USB Flash Drive** icon  on the bottom of the screen is displayed.
3. Press and hold the **Tutorial** button  3 seconds or longer. The playback menu is displayed.

Figure 12. Playback Menu



4. Navigate the menu as follows:
 - Press the **Snapshot** button  to move up the list of playback files.
 - Press the **External Video** button  to move down the list of playback files.
5. When you have selected the item that you want to play, press the **Tutorial** button . Playback starts.
6. When the file is being played back and is displayed on the screen, press the **Snapshot** button  to playback the next file above the one currently displayed. Press the **External Video** button  to play the next file below the one currently displayed.
7. If the file being played back is a video, pause and resume playback by pressing the **Tutorial** button .
8. Press the **Record** button  to return to the playback menu.
9. Press the **Record** button  again to close the playback menu.

TIPS FOR USING THE GLIDESCOPE AVL SYSTEM

- The GlideScope video laryngoscope is designed to be inserted down the midline of the tongue to the epiglottis.
- Intubations using the GlideScope video laryngoscope only require approximately 0.5–1.5 kg (1–3.5 lbs) of lifting force.
- The use of an endotracheal tube stylet is recommended. GlideRite stylets are designed to complement the angle of the GlideScope video laryngoscope and facilitate intubation.

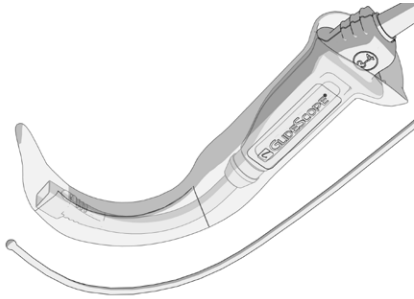

TIPS FOR WORKING WITH ENDOTRACHEAL TUBES

- Insert the ETT behind or immediately adjacent to the GlideScope video laryngoscope.
- Do not insert the stylet into the larynx during intubation.
- Carefully introduce the distal end of the ETT between the vocal folds.
- When introducing the video laryngoscope or the endotracheal tube, look directly into the mouth to avoid damaging the endotracheal tube cuff, the patient's teeth, or soft tissues such as the soft palate or tonsils.
- Avoid excessive lifting or pushing of the glottis. Maximum laryngeal exposure may not facilitate intubation; reducing the elevation applied to the laryngoscope may make inserting the ETT easier.

REPROCESSING

Some of the system components in this manual require cleaning between uses. In addition, some of them require low-level disinfection, high-level disinfection, or sterilization between uses or under specific circumstances. For information about the cleaning, disinfection, and sterilization requirements for these components, refer to the *GlideScope and GlideRite Products Reprocessing Manual* (part number 0900-5032), which is available at verathon.com/product-documentation.

MAINTENANCE & SAFETY

PERIODIC INSPECTIONS

In addition to the user performing routine inspections before and after every use, periodic inspections should be performed to ensure safe and effective operation. It is recommended that an operator familiar with the instrument perform a full visual inspection of all components at least every three months. The inspector should check the system for the following:

- External damage to the equipment
- Damage to the power supply or adapter
- Damage to the connectors or cable insulation

Report any suspected defects to Verathon Customer Care or your local representative. For contact information, visit verathon.com/global-support.

GLIDESCOPE VIDEO MONITOR BATTERY

Under normal operating conditions, the monitor battery will last 2–3 years; or approximately 500 charge/discharge cycles. For more information about the battery, see the [Component Specifications](#) section on page 41.

The battery is not user-replaceable. In case of battery malfunction, do not attempt to replace the monitor battery. Any attempts to replace the battery by unauthorized service technicians may cause serious harm to the user and will void the warranty. Please contact your Verathon Customer Care Representative for more information on battery replacement.

SYSTEM SOFTWARE

Verathon may release software upgrades for the GlideScope Video Monitor. Software upgrades are supplied directly by Verathon or an authorized representative, and installation instructions are provided with the upgrade.

This manual documents the most current version of the GlideScope Video Monitor software. If your monitor does not function as described in this manual, or to determine if your software should be updated, contact Verathon Customer Care.

Do not perform any software upgrades from third-party vendors or attempt to modify the existing software. Doing so may damage the monitor and void the warranty.

DEVICE REPAIR

The system components are not user-serviceable. Verathon does not make available any type of circuit diagrams, component parts lists, descriptions, or other information that would be required for repairing the device and related accessories. All service must be performed by a qualified technician.

If you have any questions, contact your local Verathon representative or Verathon Customer Care.



Please read the [Warnings & Cautions](#) section.

DEVICE DISPOSAL

Disposal of this device in accordance with WEEE requirements can be coordinated through your Verathon Service Center.

WARRANTY

ORIGINAL TOTAL CUSTOMER CARE WARRANTY

This Limited Warranty ("Warranty") is provided by Verathon Inc. ("Verathon") to its customer, distributor, original equipment manufacturer, end-user, or other purchaser ("Buyer") on the terms and conditions stated herein, for the GlideScope product ("Product"). The terms of this Warranty are subject to the standard Terms and Conditions of Sale or any other separate negotiated agreement between the parties.

SCOPE OF COVERAGE: This Warranty covers service and repair of all malfunctions (mechanical, electrical, and other defects) associated with the Product purchased by Buyer from Verathon, including coverage for accidental drops or mishandling of Product (subject to Buyer's payment of a deductible charge for Product replacement), for a period of one (1) year (unless otherwise noted under "COVERED COMPONENTS" below) from Product shipment date ("Term"), and applies only to the original Buyer. Replacement parts will be new, rebuilt or non-original manufacturer's parts that perform to the factory specifications of the Product at Verathon's sole option.

Verathon will perform repair and replacement services ("Service") only on Products purchased from an authorized dealer. If the Product or component is purchased from an unauthorized dealer, or if the original factory serial number has been removed, defaced or altered, this Warranty is void.

If a Product purchased by Buyer requires Service, Verathon will, at its discretion, either repair or replace the Product and may provide a loaner unit, at Buyer's request. If Buyer requests a loaner unit, Buyer shall send the defective Product to Verathon (cleaned and disinfected as appropriate) immediately upon receiving the loaner unit from Verathon. Buyer shall return the loaner unit within two (2) business days of receipt of the repaired Product. All exchanged parts become property of Verathon.

EXCLUSIONS: This Warranty excludes problems caused by the Buyer's acts (or failure to act), the acts of others, or events beyond Verathon's reasonable control including:

- Accident, theft, misuse, abuse, extraordinary wear and tear, or neglect.
- Misapplication, improper use, or other failure to follow Verathon's product instructions and safety precautions contained in the Operations and Maintenance Manual. This warranty does not apply if there is evidence of the equipment being exposed to temperatures in excess of 60°C (140°F).
- Use of the system in conjunction with hardware, software, components, services, accessories, attachments, interfaces, or consumables, other than those supplied or specified by Verathon.
- Products that have been repaired or maintained by anyone other than a Verathon authorized service provider.
- Modification, disassembly, rewiring, re-engineering, recalibration, and/or reprogramming of Products other than as specifically authorized by Verathon in writing.

COVERED COMPONENTS: Warranty coverage applies to the following components:

- GlideScope Video Monitor
- GlideScope AVL Video Baton
- GlideScope Video Baton 2.0 (two-year factory warranty)
- GlideScope Spectrum Smart Cable (two-year factory warranty)

Additional reusable components purchased either singularly or as a part of a system, including GlideScope Workstations and the GlideScope Video Cable, are limited to a one-year factory warranty unless stated otherwise. Consumable items are not covered under this warranty.

EXTENDED WARRANTIES: Buyer may purchase a Premium Total Customer Care warranty that extends this Limited Warranty. For more information, contact Verathon's Customer Care Department or your local representative.

LIMITED REMEDY: This Warranty gives Buyer specific legal rights which may vary based on local law. When, under applicable law, implied warranties are not allowed to be excluded in their entirety, such warranties will be limited to the duration of the applicable written warranty and, for European Customers, any terms herein limiting Verathon's liability shall not apply insofar as they conflict with mandatory statutory provisions of the Product Liability Act.

TO THE FULL EXTENT ALLOWED BY LAW, THE FOREGOING LIMITED WARRANTIES AND REMEDIES ARE EXCLUSIVE AND EXPRESSLY IN LIEU OF ALL OTHER WARRANTIES, REPRESENTATIONS, TERMS, OR CONDITIONS, WRITTEN OR ORAL, EXPRESS OR IMPLIED, STATUTORY OR OTHERWISE, INCLUDING BUT NOT LIMITED TO ANY WARRANTIES, TERMS OR CONDITIONS OF MERCHANTABILITY OR FITNESS FOR A PARTICULAR PURPOSE, SATISFACTORY QUALITY, CORRESPONDENCE WITH DESCRIPTION, AND NON-INFRINGEMENT, ALL OF WHICH ARE HEREBY EXPRESSLY DISCLAIMED.

TRANSFER OF SERVICE: This Warranty extends only to Buyer, and may not be transferred to third parties by operation of law or otherwise.

PRODUCT SPECIFICATIONS

COMPONENT SPECIFICATIONS

Table 4. *GlideScope Video Monitor (0570-0338)*

GENERAL SPECIFICATIONS		
Classification:	Electrical Class II, Applied Part BF	
Line voltage:	Range: 100–240 VAC, 50 and 60 Hz. Connect to a medical-grade power supply (If the provided power cord has a third prong, it is used as a functional ground).	
DC power supply:	12 V DC, 3.33 A max	
Ingress protection:	IP54	
OPERATING & STORAGE SPECIFICATIONS		
	Operating Conditions	Shipping & Storage Conditions
Temperature:	10–40°C (50–104°F)	-20–45°C (-4–113°F)
Relative humidity:	10–95%	10–95%
Atmospheric pressure:	700–1060 hPa	440-1060 hPa
COMPONENT SPECIFICATIONS		
Screen type and resolution	TFT Color VGA 640 × 480 px	
Screen size (diagonal; A)	16.3 cm (6.4 in)	
Height (B)	174 mm	
Width (C)	223 mm	
Depth (D)	80 mm	
Weight	1.0 kg	

Table 5. Spectrum Smart Cable (0800-0543)

GENERAL SPECIFICATIONS		
Ingress protection:	IPX8	
OPERATING & STORAGE SPECIFICATIONS		
	Operating Conditions	Shipping & Storage Conditions
Temperature:	10–40°C (50–104°F)	-20–45°C (-4–113°F)
Relative humidity:	10–95%	10–95%
Atmospheric pressure:	700–1060 hPa	440–1060 hPa
COMPONENT SPECIFICATIONS		
Length (A)	1417 ± 25 mm	
Diameter (B)	6.8 mm	

Table 6. Premium Cart (0800-0537)

OPERATING & STORAGE SPECIFICATIONS		
	Operating Conditions	Shipping & Storage Conditions
Temperature:	10–40°C (50–104°F)	-20–45°C (-4–113°F)
Relative humidity:	10–95%	10–95%
Atmospheric pressure:	700–1060 hPa	440–1060 hPa
COMPONENT SPECIFICATIONS		
Wheelbase diameter (A)	53.3 cm	
Minimum height (B)	101.6 cm	
Maximum height (C)	132.1 cm	
Weight	8.0–8.4 kg	

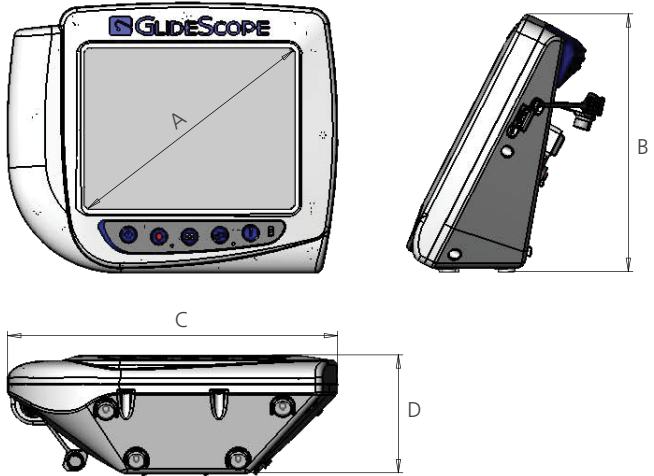
Table 7. Mobile Stand (0800-0410)

OPERATING & STORAGE SPECIFICATIONS		
	Operating Conditions	Shipping & Storage Conditions
Temperature:	10–40°C (50–104°F)	-20–45°C (-4–113°F)
Relative humidity:	10–95%	10–95%
Atmospheric pressure:	700–1060 hPa	440-1060 hPa
COMPONENT SPECIFICATIONS		
Wheelbase diameter (A)	61 cm	
Minimum height (B)	76 cm	
Maximum height (C)	122 cm	

Table 8. IV Pole Mount (0810-0200)

OPERATING & STORAGE SPECIFICATIONS		
	Operating Conditions	Shipping & Storage Conditions
Temperature:	10–40°C (50–104°F)	-20–45°C (-4–113°F)
Relative humidity:	10–95%	10–95%
Atmospheric pressure:	700–1060 hPa	440-1060 hPa
COMPONENT SPECIFICATIONS		
Arm length (A)	27 cm	
Width (B)	6.3 cm	
Pole width range (C)	6.4–33 mm	
Weight	0.9 kg	

Table 9. AVL Video Baton 1-2 (0570-0306)

GENERAL SPECIFICATIONS		
Ingress protection:	IPX8	
Expected product life:	2 years or 1000 cycles	
OPERATING & STORAGE SPECIFICATIONS		
	Operating Conditions	Shipping & Storage Conditions
Temperature:	10–40°C (50–104°F)	-20–45°C (-4–113°F)
Relative humidity:	10–95%	10–95%
Atmospheric pressure:	700–1060 hPa	440-1060 hPa
COMPONENT SPECIFICATIONS		
Length of flexible portion of baton (A)	66.0 mm	 <p>Cable shortened for illustrative purposes</p>
Height at camera (B)	6.0 mm	
Width at camera (C)	7.0 mm	
Video cable length (D)	2041 ± 50 mm	
Field of view (E)	41°	
Direction of view	0°	

Table 10. AVL Video Baton 3-4 (0570-0307)

GENERAL SPECIFICATIONS		
Ingress protection:	IPX8	
Expected product life:	2 years or 1000 cycles	
OPERATING & STORAGE SPECIFICATIONS		
	Operating Conditions	Shipping & Storage Conditions
Temperature:	10–40°C (50–104°F)	-20–45°C (-4–113°F)
Relative humidity:	10–95%	10–95%
Atmospheric pressure:	700–1060 hPa	440-1060 hPa
COMPONENT SPECIFICATIONS		
Length of flexible portion of baton (A)	105.0 mm	 <p>Cable shortened for illustrative purposes</p>
Height at camera (B)	11 mm	
Width at camera (C)	11 mm	
Video cable length (D)	1540 ± 50 mm	
Field of view (E)	49°	
Direction of view	0°	

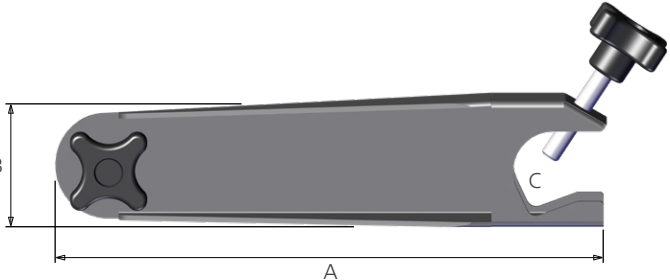
Table 11. AVL Video Baton 2.0 Large (3-4; 0570-0382)

GENERAL SPECIFICATIONS		
Ingress protection:	IPX8	
Expected product life:	2 years or 2000 cycles	
OPERATING & STORAGE SPECIFICATIONS		
	Operating Conditions	Shipping & Storage Conditions
Temperature:	10–40°C (50–104°F)	-20–45°C (-4–113°F)
Relative humidity:	10–95%	10–95%
Atmospheric pressure:	700–1060 hPa	440-1060 hPa
COMPONENT SPECIFICATIONS		
Length of flexible portion of baton (A)	105.0 mm	
Height at camera (B)	11 mm	
Width at camera (C)	11 mm	
Field of view (D)	49°	
Direction of view	0°	

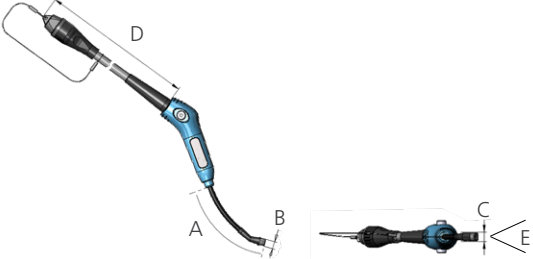
Table 12. GVL Stat 0 (0574-0104)

GENERAL SPECIFICATIONS		
Expected product life:	Refer to the “use by” date indicated by the ☞ symbol on the package label.	
OPERATING & STORAGE SPECIFICATIONS		
	Operating Conditions	Shipping & Storage Conditions
Temperature:	10–40°C (50–104°F)	0–45°C (32–113°F)
Relative humidity:	10–95%	10–95%
Atmospheric pressure:	700–1060 hPa	800–1060 hPa
COMPONENT SPECIFICATIONS		
Height at camera (A)	8.6 mm	
Blade tip to handle (B)	36.2 mm	
Width at camera (C)	11.0 mm	
Blade length in front of camera (D)	6.5 mm	
Max blade width in front of camera (E)	11.0 mm	
Insertion portion (IP) length (F)	42 mm	
Insertion portion (IP) width	15 mm	

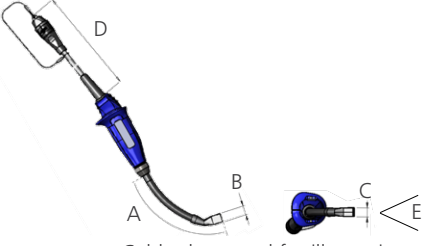
Table 13. GVL Stat 1 (0574-0026)

GENERAL SPECIFICATIONS		
Expected product life:	Refer to the “use by” date indicated by the  symbol on the package label.	
OPERATING & STORAGE SPECIFICATIONS		
	Operating Conditions	Shipping & Storage Conditions
Temperature:	10–40°C (50–104°F)	0–45°C (32–113°F)
Relative humidity:	10–95%	10–95%
Atmospheric pressure:	700–1060 hPa	800–1060 hPa
COMPONENT SPECIFICATIONS		
Height at camera (A)	8.6 mm	
Blade tip to handle (B)	43.5 mm	
Width at camera (C)	10.1 mm	
Blade length in front of camera (D)	15.0 mm	
Max blade width in front of camera (E)	12.7 mm	
Insertion portion (IP) length (F)	50 mm	
Insertion portion (IP) width	15 mm	

Table 14. GVL Stat 2 (0574-0027)

GENERAL SPECIFICATIONS		
Expected product life:	Refer to the “use by” date indicated by the  symbol on the package label.	
OPERATING & STORAGE SPECIFICATIONS		
	Operating Conditions	Shipping & Storage Conditions
Temperature:	10–40°C (50–104°F)	0–45°C (32–113°F)
Relative humidity:	10–95%	10–95%
Atmospheric pressure:	700–1060 hPa	800–1060 hPa
COMPONENT SPECIFICATIONS		
Height at camera (A)	8.6 mm	
Blade tip to handle (B)	55.7 mm	
Width at camera (C)	11.2 mm	
Blade length in front of camera (D)	28.0 mm	
Max blade width in front of camera (E)	16.0 mm	
Insertion portion (IP) length (F)	62 mm	
Insertion portion (IP) width	18 mm	

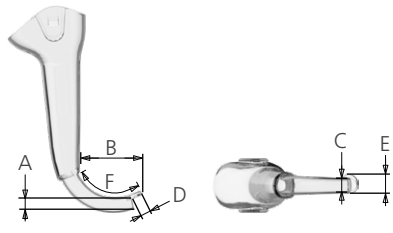
Table 15. GVL Stat 2.5 (0574-0110)

GENERAL SPECIFICATIONS		
Expected product life:	Refer to the “use by” date indicated by the ⏰ symbol on the package label.	
OPERATING & STORAGE SPECIFICATIONS		
	Operating Conditions	Shipping & Storage Conditions
Temperature:	10–40°C (50–104°F)	0–45°C (32–113°F)
Relative humidity:	10–95%	10–95%
Atmospheric pressure:	700–1060 hPa	800–1060 hPa
COMPONENT SPECIFICATIONS		
Height at camera (A)	9.1 mm	
Blade tip to handle (B)	63.4 mm	
Width at camera (C)	12.7 mm	
Blade length in front of camera (D)	37.0 mm	
Max blade width in front of camera (E)	19.7 mm	
Insertion portion (IP) length (F)	74 mm	
Insertion portion (IP) width	22 mm	

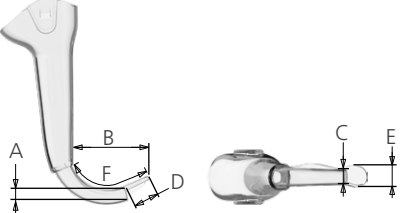
Table 16. GVL Stat 3 (0574-0100)

GENERAL SPECIFICATIONS		
Expected product life:	Refer to the “use by” date indicated by the ⏰ symbol on the package label.	
OPERATING & STORAGE SPECIFICATIONS		
	Operating Conditions	Shipping & Storage Conditions
Temperature:	10–40°C (50–104°F)	-20–45°C (-4–113°F)
Relative humidity:	10–95%	10–95%
Atmospheric pressure:	700–1060 hPa	595–1060 hPa
COMPONENT SPECIFICATIONS		
Height at camera (A)	14.3 mm	
Blade tip to handle (B)	72.5 mm	
Width at camera (C)	16.0 mm	
Blade length in front of camera (D)	37.0 mm	
Max blade width in front of camera (E)	19.7 mm	
Insertion portion (IP) length (F)	89 mm	
Insertion portion (IP) width	25 mm	

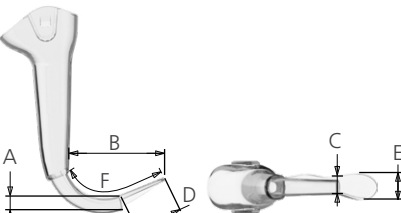
Table 17. GVL Stat 4 (0574-0101)

GENERAL SPECIFICATIONS		
Expected product life:	Refer to the “use by” date indicated by the ⏰ symbol on the package label.	
OPERATING & STORAGE SPECIFICATIONS		
	Operating Conditions	Shipping & Storage Conditions
Temperature:	10–40°C (50–104°F)	-20–45°C (-4–113°F)
Relative humidity:	10–95%	10–95%
Atmospheric pressure:	700–1060 hPa	595–1060 hPa
COMPONENT SPECIFICATIONS		
Height at camera (A)	14.3 mm	
Blade tip to handle (B)	87.0 mm	
Width at camera (C)	20.3 mm	
Blade length in front of camera (D)	52.0 mm	
Max blade width in front of camera (E)	27.5 mm	
Insertion portion (IP) length (F)	105 mm	
Insertion portion (IP) width	30 mm	

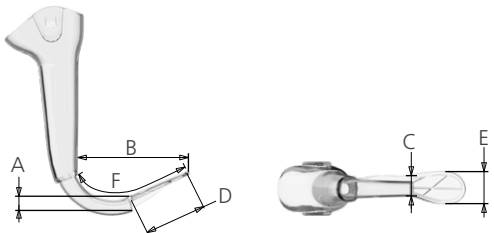
BATTERY SPECIFICATIONS

Table 18. Battery Specifications

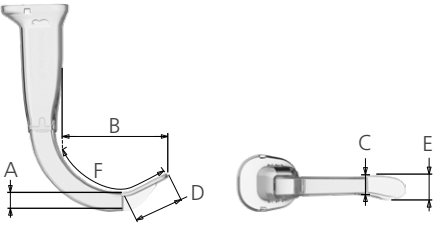
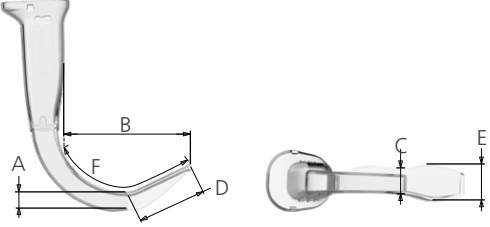
CONDITION	DESCRIPTION
Battery type	Lithium-ion
Battery life	Under normal operating conditions, a fully charged battery lasts approximately 90 minutes
Charging time	Charging time off line will take no more than 6 hours from an empty battery to a full charge
Rated capacity	2150 mAh
Nominal voltage	7.2 V
Max charging voltage	8.4 V
Nominal weight	90 g (3.17 oz)
Width	23 mm (0.9 in)
Length	391 mm (5.4 in)
Thickness	23 mm (0.9 in)

ELECTROMAGNETIC COMPATIBILITY

The system is designed to be in compliance with IEC 60601-1-2, which contains electromagnetic compatibility (EMC) requirements for medical electrical equipment. The limits for emissions and immunity specified in this standard are designed to provide reasonable protection against harmful interference in a typical medical installation.

The system complies with the applicable essential performance requirements specified in IEC 60601-1 and IEC 60601-2-18. Results of immunity testing show that the essential performance of the system is not affected under the test conditions described in the following tables. For more information about the essential performance of the system, see [Essential Performance](#) on page 1.

ELECTROMAGNETIC EMISSIONS

Table 19. Guidance and Manufacturer’s Declaration—Electromagnetic Emissions

The system is intended for use in the electromagnetic environment specified below. The customer or the user of the system should ensure that it is used in such an environment.

EMISSIONS TEST	COMPLIANCE	ELECTROMAGNETIC ENVIRONMENT – GUIDANCE
RF emissions CISPR 11	Group 1	The system uses RF energy only for its internal function. Therefore, its RF emissions are very low and are not likely to cause any interference in nearby electronic equipment.
RF emissions CISPR 11	Class A	The system is suitable for use in all establishments other than domestic and those directly connected to the public low-voltage power supply network that supplies buildings used for domestic purposes.
Harmonic emissions IEC 61000-3-2	Class A	
Voltage fluctuations/ flicker emissions IEC 61000-3-3	In compliance	

ELECTROMAGNETIC IMMUNITY

Table 20. Guidance and Manufacturer's Declaration—Electromagnetic Immunity

The system is intended for use in the electromagnetic environment specified below. The customer or the user of the system should ensure that it is used in such an environment.

IMMUNITY TESTS	IEC 60601 TEST LEVEL	COMPLIANCE LEVEL	ELECTROMAGNETIC ENVIRONMENT – GUIDANCE
Electrostatic discharge (ESD) IEC 61000-4-2	± 8 kV contact ± 15 kV air	In compliance	Floors should be wood, concrete, or ceramic tile. If floors are covered with synthetic material, the relative humidity should be at least 30%.
Electrical fast transient/burst IEC 61000-4-4	± 2 kV for power supply lines 100 kHz repetition frequency	In compliance	Mains power quality should be that of a typical hospital environment.
Surge IEC 61000-4-5	± 1 kV line(s) to line(s) ± 2 kV line(s) to earth	In compliance	Mains power quality should be that of a typical hospital environment.
Voltage dips, short interruptions and voltage variations on power supply input lines IEC 61000-4-11	0% U_T ; 0.5 Cycle At 0°, 45°, 90°, 135°, 180°, 225°, 270°, and 315° 0% U_T ; 1 cycle and 70% U_T ; 25/30 cycles Single Phase: at 0°	In compliance	Mains power quality should be that of a typical hospital environment. If the user of the system requires continued operation during power mains interruptions, it is recommended that the system be powered from an uninterruptible power supply or a battery.
Rated power frequency magnetic fields IEC 61000-4-8	30 A/m Frequency 50/60 Hz	In compliance	Power frequency magnetic fields should be at levels characteristic of a typical location in a typical hospital environment.
Conducted RF IEC 61000-4-6	3 Vrms 150 kHz to 80 MHz 6 Vrms in ISM bands 150 kHz to 80 MHz 80% AM at 1 kHz	In compliance	Portable and mobile RF communications equipment should be used no closer to any part of the system, including cables, than the recommended separation distance calculated from the equation applicable to the frequency of the transmitter. Recommended separation distance d (m) $d=1.2 \sqrt{P}$

Table 20. Guidance and Manufacturer’s Declaration—Electromagnetic Immunity

The system is intended for use in the electromagnetic environment specified below. The customer or the user of the system should ensure that it is used in such an environment.

IMMUNITY TESTS	IEC 60601 TEST LEVEL	COMPLIANCE LEVEL	ELECTROMAGNETIC ENVIRONMENT – GUIDANCE
Radiated RF IEC 61000-4-3	3 V/m 80 MHz to 2.7 GHz 80% AM at 1 kHz	In compliance	Interference may occur in the vicinity of equipment marked with the following symbol: 

Note: U_T is the AC mains voltage prior to application of the test level.

These guidelines may not apply in all situations. Electromagnetic propagation is affected by absorption and reflection from structures, objects and people.

ACCESSORY CONFORMANCE TO STANDARDS

To maintain electromagnetic interference (EMI) within certified limits, the system must be used with the cables, components, and accessories specified or supplied by Verathon. For additional information, see the [System Parts & Accessories](#) and [Component Specifications](#) sections. The use of accessories or cables other than those specified or supplied may result in increased emissions or decreased immunity of the system.

Table 21. EMC Standards for Accessories

ACCESSORY	LENGTH
AC power cord	4.5 m (15.0 ft)
DC medical power adapter cable	2.5 m (8.2 ft)
HDMI-to-DVI cable	4.6 m (15.1 ft)
Smart Cable	1.6 m (5.2 ft)

GLOSSARY

The following table provides definitions for specialized terms used in this manual or on the product itself. For a full list of caution, warning, and informational symbols used on this and other Verathon products, please refer to the *Verathon Symbol Glossary* (part number 0900-4757) at verathon.com/symbols.

TERM	DEFINITION
A	Ampere
AC	Alternating current
C	Celsius
CFR	Code of Federal Regulations (U.S.)
CISPR	International Special Committee on Radio Interference
cm	Centimeter
DC	Direct current
DL	Direct laryngoscopy
ED	Emergency Department
EMI	Electromagnetic interference
ESD	Electrostatic discharge
Essential performance	The system performance necessary to achieve freedom from unacceptable risk
ETT	Endotracheal tube
F	Fahrenheit
g	Gram
GHz	Gigahertz
HDMI	High-definition multimedia interface
hPa	Hectopascal
Hz	Hertz
ICU	Intensive Care Unit
IEC	International Electrotechnical Commission
in	Inch
IPA	Isopropyl alcohol
ISM	Industrial, scientific, and medical
kHz	Kilohertz
kV	Kilovolt
lbs	Pounds
m	Meter
mAh	Milliampere-hour
MHz	Megahertz
mm	Millimeter
NICU	Neonatal Intensive Care Unit
OR	Operating Room

TERM	DEFINITION
OSHA	Occupational Safety and Health Administration (federal agency in U.S.)
oz	Ounce
ppm	Parts per million
RF	Radio frequency
RH	Relative humidity
V	Volt
Vrms	Voltage root mean squared
WEEE	Waste electrical and electronic equipment

