



Product Catalog

# Split System Air Conditioners Odyssey™ with Symbio™ Controls

R-22 Dry Charge, Cooling Condenser  
7.5, 10, 15 and 20 Tons, 60 Hz





## Introduction



Odyssey™ Split Systems offer a wide range of options, allowing you to easily match unit tonnage with the right load requirements.

When a project calls for the convenience and cost efficiency of a unitary product, where a rooftop unit isn't right, Odyssey may be the answer. It provides heating and cooling in a split configuration that's unique in its versatility while staying true to our standards for efficiency and reliability. And with the Symbio® digital controller on board, Odyssey introduces smart building capabilities that take service, comfort and sustainability beyond the expected.

With wide network availability, flexible applications, installation ease, built-in reliability and easy servicing, Odyssey will meet any number of customer applications. Add to that Trane's outstanding customer service and you have the formula to make Odyssey the clear choice for continued customer satisfaction.

## Wide network availability

A broad distribution network provides owners, maintenance personnel, contractors, etc., the means to get their hands on equipment when they need it. Whether it's an emergency replacement or a new construction project in its infancy stages, Odyssey products meet an array of needs at the right time and right price.

## Flexible applications

No matter what the application, Odyssey provides the solution. A broad array of models and tonnages are available with single or dual compressors, single or dual circuits and numerous accessories. Condensing units can be installed on the ground or on a rooftop along with extended piping runs, while air handlers can be free discharge on the ground or horizontally suspended with long duct runs from a ceiling. Should application challenges arise, Odyssey delivers.

## Easy to install

Small footprints and low weights combined with factory installed components like TXVs, filter driers, etc., reduce installation time and cost. Colored connectors and wiring, as well as factory-tested units make Odyssey the right choice.

## Built-in reliability

Keeping in mind that productivity only occurs when equipment is operational, Trane has taken the steps to ensure that Odyssey is up and running. Early indicators such as phase/reversal

monitors and loss of charge protection provide diagnostics which prevent failure and provide years of worry-free service and operation.

## **Easy to service**

When preventive maintenance or service is required, technicians will find efficient access to both air handlers and condensers. Panels provide complete, easy access coupled with standardized cabinets in which all components are located in proximity. Odyssey's improved design results in minimum service times and costs.

With these capabilities, Odyssey provides customers high efficiency and superior performance for the best all-around value in the market today.

## **Copyright**

This document and the information in it are the property of Trane, and may not be used or reproduced in whole or in part without written permission. Trane reserves the right to revise this publication at any time, and to make changes to its content without obligation to notify any person of such revision or change.

## **Trademarks**

All trademarks referenced in this document are the trademarks of their respective owners.

## **Revision History**

Updated the Table 1 – TTA Accessories in the Accessories chapter.



# Table of Contents

Accessories.....	5
Cooling Condenser .....	5
Model Number Description .....	6
Cooling Condenser .....	6
General Data.....	7
Performance Data .....	8
Electrical Data .....	12
Cooling Condenser .....	13
Weights.....	16
Cooling Condenser .....	16



# Accessories

## Cooling Condenser

Table 1. TTA Accessories

Model	Used With
<b>Coil (Hail/Vandal) Guard</b>	
BAYGARD063*	TTA0902*A
BAYGARD064*	TTA1202*A
BAYGARD066*	TTA1802*D, TTA2402*D
<b>Rubber Isolators</b>	
BAYISLT004* (blue)	TTA0902*A
BAYISLT005* (black)	TTA1202*A
BAYISLT009* (red)	TTA1802*D
BAYISLT010* (green)	TTA2402*D
<b>Steel Spring Isolators</b>	
BAYISLT023* (red)	TTA0902*A, TTA1202*A
BAYISLT024* (black)	TTA1802*D
BAYISLT025* (yellow)	TTA2402*D
<b>Service Valve Kit</b>	
BAYVALV001*	TTA0902*A, TTA1202*A
BAYVALV005*	TTA1802*D, TTA2402*D
<b>Low Ambient – On/Off Fan Control<sup>(a)</sup> (b)</b>	
BAYLOAMS10* (External Mount, small cabinets) <sup>(c)</sup>	(all voltages) TTA0902*A
BAYLOAMS20* (Internal mount, large cabinets)	(all voltages) TTA1202*A, TTA1802*D, TTA2402*D
<b>LonTalk Communications Interface<sup>(d)</sup></b>	
BAYLTCI005*	All Models
<b>Expansion Module Kit</b>	
BAYMODU002* (XM30)	All Models
BAYMODU004* (XM32)	All Models

<sup>(a)</sup> Cycles fan on/off (no modulating).

<sup>(b)</sup> When BAYLOAM is used, the Evaporator Defrost Control (EDC) must be disabled in the Symbio 700 controller configuration.

<sup>(c)</sup> Kit mounts external to the outdoor unit and operates by sensing ambient temperature and discharge pressure.

<sup>(d)</sup> Field installed LonTalk interface requires installation of Symbio control board with Advanced Diagnostics (not included).



# Model Number Description

## Cooling Condenser

### Digit 1, 2, 3— Unit Function

TTA = Split System Cooling

### Digit 4, 5, 6 — Tonnage

090 = 7.5 Tons (60 Hz)

120 = 10 Tons (60 Hz)

180 = 15 Tons (60 Hz)

240 = 20 Tons (60 Hz)

### Digit 7 — Refrigerant

2 = R-22

### Digit 8 — Voltage

3 = 208-230 Vac - 3 PH (60Hz)

4 = 460 Vac - 3 PH (60Hz)

### Digit 9 — Refrigeration Circuit/Stage

A = 1 Compressor/1 Line/1 Stage (Single)

D = 2 Compressors/2 Line/2 Stage (Dual)

### Digit 10 — Major Design Sequence

A = Rev A

### Digit 11 — Minor Design Sequence

A = Rev A

### Digit 12, 13 — Service Digits

\*\*

### Digit 14 — Efficiency Generation

A = Generation A

### Digit 15 — Controls

S = Symbio™

### Digit 16 — None

0 = None

### Digit 17 — Coil Protection

0 = Standard Coil

### Digit 18, 19, 20 — None

0 = None

### Digit 21 — Communications Options

0 = No Option

1 = Advanced Diagnostics and BACnet® BAS

2 = Advanced Diagnostics and LonTalk®  
Communications Interface (LCI)

### Digit 22 to 40 — None

0 = None



# General Data

Table 2. General Data – 7.5 to 20 ton

	7.5 Tons	10 Tons	15 Tons	20 Tons
	Single Compressor TTA0902*A*	Single Compressor TTA1202*D*	Dual Compressor TTA1802*D*	Dual Compressor TTA2402*D*
<b>Compressor</b>				
Type	Scroll	Scroll	Scroll	Scroll
No./Tons	1/6.9	1/8.6	2/6.9	2/8.6
<b>System Data</b>				
No. Refrigerant Circuits	1	1	2	2
Suction Line Connection (in.) OD	1 3/8	1 3/8	1 3/8	1 3/8
Liquid Line Connection (in.) OD	1/2	1/2	1/2	1/2
<b>Outdoor Coil</b>				
Type	MCHE	MCHE	MCHE	MCHE
Tube Size (in.) OD	0.8	0.8	0.8	0.8
Face Area (sq ft)	18.5	23.8	44.3	44.3
Rows/FPI (Fins per inch)	1/23	1/23	1/23	1/23
<b>Outdoor Fan</b>				
Type	Propeller	Propeller	Propeller	Propeller
No. Used/Diameter (in.)	1/26	1/28	2/28	2/28
Drive Type/No. Speeds	Direct/1	Direct/1	Direct/1	Direct/1
CFM	5,100	7,800	15,500	15,500
No. Motor/HP	1/0.5	1/1	2/1	2/1
Motor RPM	1,100	1,100	1,100	1,100
<b>Shipping Dimensions</b>				
HxWxD (in.)	45" x 45" x 38"	45" x 55" x 42"	51.1" x 96" x 48"	51.1" x 96" x 48"



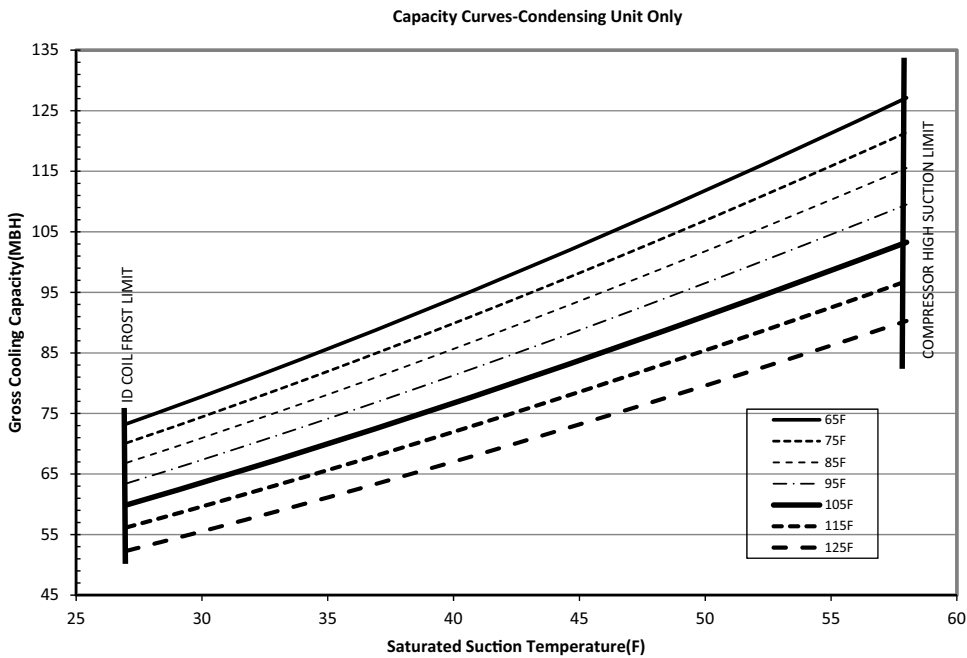
# Performance Data

**Table 3. Gross cooling capacities (MBH) 7.5 tons TTA0902\*A condensing unit only (IP)**

Outdoor Temp (°F)		Suction Temperature (°F)					
		30	35	40	45	50	55
65	Head Press (psig)	162.4	167.7	173.4	179.5	186.0	192.8
	Capacity (Btuh/1000)	77.8	85.7	94.0	102.7	111.8	121.3
	Unit Power (kW)	4.9	5.0	5.2	5.4	5.5	5.7
75	Head Press (psig)	186.3	191.7	197.6	203.8	210.4	217.3
	Capacity (Btuh/1000)	74.4	82.0	89.9	98.2	106.9	115.9
	Unit Power (kW)	5.3	5.5	5.6	5.8	6.0	6.1
85	Head Press (psig)	212.8	218.4	224.4	230.7	237.5	244.5
	Capacity (Btuh/1000)	71.0	78.1	85.7	93.6	101.8	110.3
	Unit Power (kW)	5.8	6.0	6.1	6.3	6.5	6.6
95	Head Press (psig)	242.0	247.8	253.9	260.4	267.3	274.6
	Capacity (Btuh/1000)	67.3	74.1	81.3	88.8	96.5	104.6
	Unit Power (kW)	6.4	6.5	6.7	6.9	7.0	7.2
105	Head Press (psig)	273.9	279.9	286.3	293.0	300.1	307.5
	Capacity (Btuh/1000)	63.6	70.0	76.7	83.8	91.1	98.6
	Unit Power (kW)	7.0	7.2	7.3	7.5	7.7	7.9
115	Head Press (psig)	308.8	315.0	321.5	328.4	335.7	343.4
	Capacity (Btuh/1000)	59.6	65.6	72.0	78.6	85.4	92.5
	Unit Power (kW)	7.7	7.9	8.1	8.2	8.4	8.6
125	Head Press (psig)	346.6	352.9	359.7	366.8	374.3	382.2
	Capacity (Btuh/1000)	55.5	61.1	67.0	73.2	79.6	86.2
	Unit Power (kW)	8.5	8.7	8.9	9.1	9.3	9.5

**Note:** Performance data calculated at 15°F subcooling and 15°F superheat and does not include capacity loss due to refrigerant lines.

**Figure 1. TTA0902\*A capacity curves**

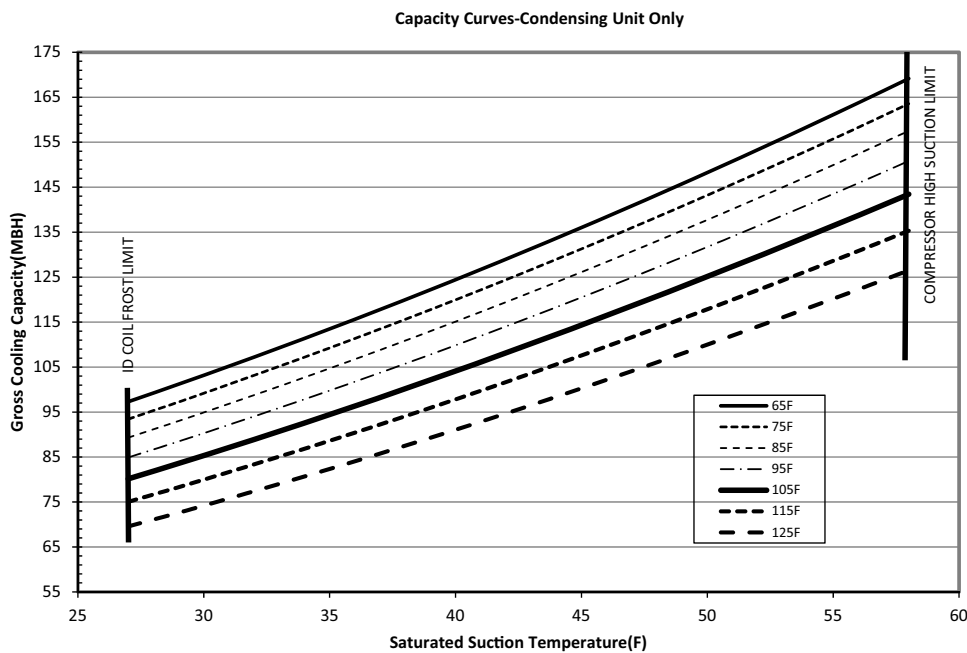




**Table 4. Gross cooling capacities (MBH) 10 tons TTA1202\*A condensing unit only (IP)**

Outdoor Temp (°F)		Suction Temperature (°F)					
		30	35	40	45	50	55
65	Head Press (psig)	164.6	169.7	175.2	181.1	187.3	194.0
	Capacity (Btuh/1000)	103.2	113.5	124.4	136.0	148.2	161.1
	Unit Power (kW)	7.2	7.4	7.6	7.8	8.1	8.3
75	Head Press (psig)	189.9	195.4	201.2	207.4	213.9	220.8
	Capacity (Btuh/1000)	99.2	109.3	119.9	131.3	143.2	155.7
	Unit Power (kW)	7.7	7.9	8.2	8.4	8.6	8.9
85	Head Press (psig)	218.0	223.8	229.9	236.4	243.3	250.5
	Capacity (Btuh/1000)	94.9	104.7	115.1	126.1	137.7	149.9
	Unit Power (kW)	8.4	8.6	8.8	9.0	9.3	9.5
95	Head Press (psig)	248.9	255.1	261.6	268.4	275.5	283.1
	Capacity (Btuh/1000)	90.3	99.8	109.8	120.5	131.7	143.5
	Unit Power (kW)	9.1	9.4	9.6	9.8	10.0	10.3
105	Head Press (psig)	282.9	289.4	296.2	303.3	310.8	318.6
	Capacity (Btuh/1000)	85.3	94.4	104.1	114.3	125.1	136.4
	Unit Power (kW)	10.0	10.2	10.4	10.7	10.9	11.1
115	Head Press (psig)	319.9	326.7	333.9	341.4	349.1	357.3
	Capacity (Btuh/1000)	80.0	88.6	97.8	107.6	117.9	128.6
	Unit Power (kW)	10.9	11.2	11.4	11.6	11.9	12.1
125	Head Press (psig)	360.1	367.3	374.8	382.6	390.6	399.0
	Capacity (Btuh/1000)	74.2	82.3	91.1	100.3	110.0	120.2
	Unit Power (kW)	12.0	12.2	12.4	12.7	12.9	13.2

**Note:** Performance data calculated at 15°F subcooling and 15°F superheat and does not include capacity loss due to refrigerant lines.

**Figure 2. TTA1202\*A capacity curves**




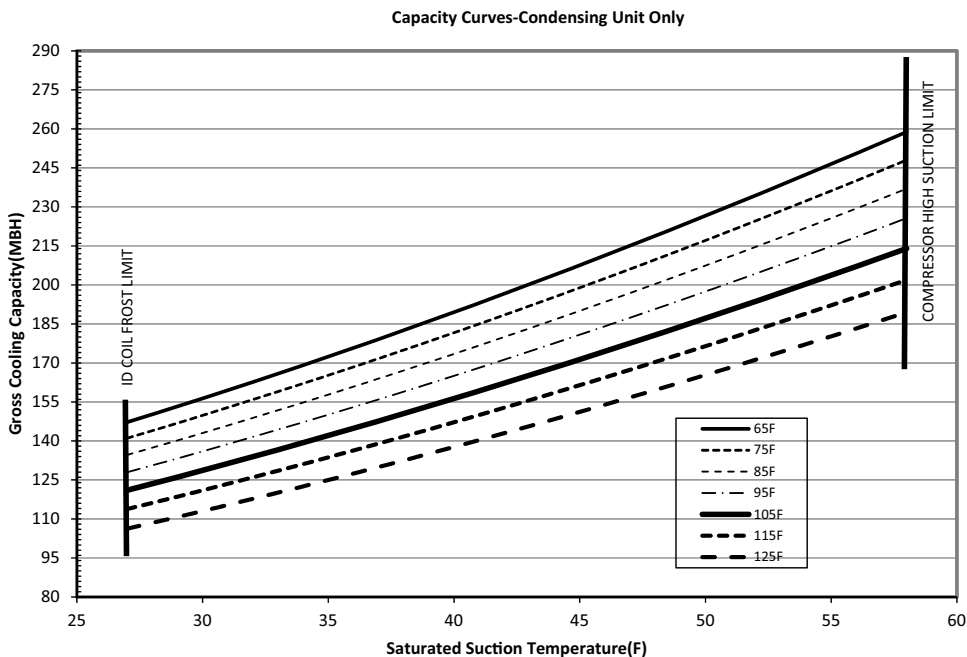
## Performance Data

**Table 5. Gross cooling capacities (MBH) 15 tons TTA1802\*D condensing unit only (IP)**

Outdoor Temp (°F)		Suction Temperature (°F)					
		30	35	40	45	50	55
65	Head Press (psig)	148.8	152.3	156.3	160.5	165.0	169.8
	Capacity (Btuh/1000)	156.3	172.4	189.5	207.6	226.6	246.5
	Unit Power (kW)	10.4	10.7	10.9	11.2	11.5	11.8
75	Head Press (psig)	171.8	175.6	179.7	184.0	188.7	193.5
	Capacity (Btuh/1000)	149.8	165.3	181.6	198.9	217.1	236.2
	Unit Power (kW)	11.2	11.4	11.7	12.0	12.2	12.5
85	Head Press (psig)	197.6	201.5	205.7	210.2	214.9	219.9
	Capacity (Btuh/1000)	143.0	157.8	173.5	190.0	207.4	225.7
	Unit Power (kW)	12.1	12.3	12.6	12.9	13.1	13.4
95	Head Press (psig)	226.1	230.2	234.5	239.1	243.9	249.0
	Capacity (Btuh/1000)	136.0	150.1	165.0	180.9	197.5	214.9
	Unit Power (kW)	13.2	13.4	13.7	13.9	14.2	14.5
105	Head Press (psig)	257.4	261.6	266.1	270.8	275.8	281.0
	Capacity (Btuh/1000)	128.7	142.1	156.3	171.3	187.2	203.7
	Unit Power (kW)	14.4	14.6	14.9	15.2	15.4	15.7
115	Head Press (psig)	291.6	296.0	300.6	305.5	310.6	316.0
	Capacity (Btuh/1000)	121.0	133.7	147.2	161.4	176.5	192.2
	Unit Power (kW)	15.7	16.0	16.3	16.5	16.8	17.1
125	Head Press (psig)	328.9	333.4	338.1	343.1	348.5	354.0
	Capacity (Btuh/1000)	113.0	125.0	137.7	151.2	165.4	180.2
	Unit Power (kW)	17.2	17.5	17.8	18.1	18.4	18.7

**Note:** Performance data calculated at 15°F subcooling and 15°F superheat and does not include capacity loss due to refrigerant lines.

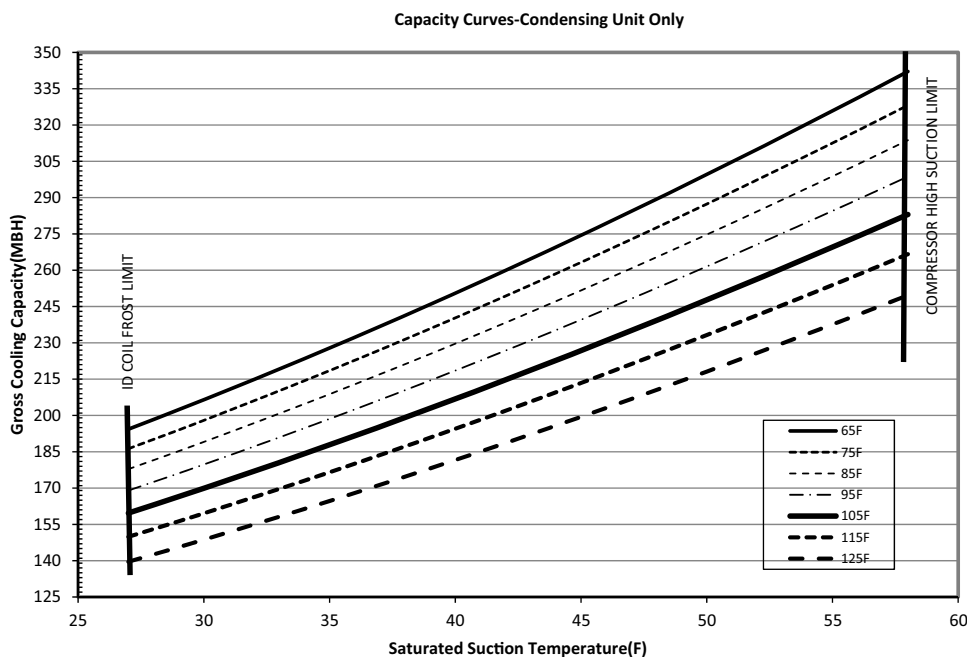
**Figure 3. TTA1802\*D capacity curves**



**Table 6. Gross cooling capacities (MBH) 20 tons TTA2402\*D condensing unit only (IP)**

Outdoor Temp (°F)		Suction Temperature (°F)					
		30	35	40	45	50	55
65	Head Press (psig)	160.3	165.3	170.7	176.4	182.6	189.1
	Capacity (Btuh/1000)	206.5	227.9	250.5	274.4	299.5	325.8
	Unit Power (kW)	14.2	14.6	15.0	15.4	15.8	16.3
75	Head Press (psig)	184.6	189.8	195.4	201.4	207.7	214.4
	Capacity (Btuh/1000)	198.0	218.5	240.3	263.3	287.3	312.5
	Unit Power (kW)	15.3	15.6	16.0	16.5	16.9	17.4
85	Head Press (psig)	211.4	216.9	222.7	228.9	235.4	242.3
	Capacity (Btuh/1000)	189.1	208.8	229.7	251.7	274.7	298.8
	Unit Power (kW)	16.5	16.9	17.3	17.7	18.2	18.6
95	Head Press (psig)	240.9	246.6	252.7	259.1	265.8	272.9
	Capacity (Btuh/1000)	179.7	198.6	218.5	239.5	261.5	284.5
	Unit Power (kW)	17.9	18.3	18.7	19.2	19.6	20.1
105	Head Press (psig)	273.2	279.1	285.4	292.1	299.0	306.4
	Capacity (Btuh/1000)	169.9	187.8	206.8	226.8	247.7	269.5
	Unit Power (kW)	19.5	19.9	20.3	20.8	21.2	21.7
115	Head Press (psig)	308.3	314.5	321.0	327.9	335.1	342.7
	Capacity (Btuh/1000)	159.6	176.5	194.5	213.4	233.2	253.9
	Unit Power (kW)	21.3	21.7	22.1	22.5	23.0	23.4
125	Head Press (psig)	346.4	352.8	359.6	366.7	374.2	382.0
	Capacity (Btuh/1000)	148.7	164.7	181.6	199.4	218.1	237.6
	Unit Power (kW)	23.2	23.6	24.0	24.5	24.9	25.4

**Note:** Performance data calculated at 15°F subcooling and 15°F superheat and does not include capacity loss due to refrigerant lines.

**Figure 4. TTA2402\*D capacity curves**




# Electrical Data

**Table 7. Electrical characteristics — compressor and condenser fan motors — 60 Hz**

Tons	Unit Model Number	Compressor						Condenser Fan Motor				
		Volts	Phase	Compressor 1		Compressor 2		No.	Volts	Phase	Amps	
				RLA Amps	LRA Amps	RLA Amps	LRA Amps				FLA (Ea.)	LRA (Ea.)
7.5	TTA09023A	208-230	3	22.4	164	N/A	N/A	1	208-230	3	2.2	8.4
	TTA09024A	460	3	10.9	100	N/A	N/A	1	460	3	1.3	4.2
10	TTA12023A	208-230	3	30.1	231	N/A	N/A	1	208-230	3	4.8	20.0
	TTA12024A	460	3	15.5	114	N/A	N/A	1	460	3	2.5	10.1
15	TTA18023D	208-230	3	22.4	164	22.4	164	2	208-230	3	4.8	20.0
	TTA18024D	460	3	10.9	100	10.9	100	2	460	3	2.5	10.1
20	TTA24023D	208-230	3	30.1	231	30.1	231	2	208-230	3	4.8	20.0
	TTA24024D	460	3	15.5	114	15.5	114	2	460	3	2.5	10.1

**Note:** Electrical characteristics reflect nameplate values and are calculated in accordance with cULus specifications.

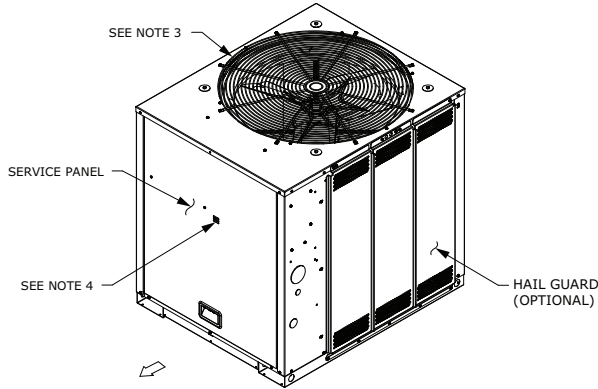
**Table 8. Unit wiring — condensing units — 60 Hz**

Tons	Unit Model Number	Volts	Minimum Circuit Ampacity	Maximum Fuse or Circuit Breaker Size
7.5	TTA09023A	208-230	30	50
	TTA09024A	460	15	25
10	TTA12023A	208-230	42	70
	TTA12024A	460	22	35
15	TTA18023D	208-230	60	80
	TTA18024D	460	30	40
20	TTA24023D	208-230	77	100
	TTA24024D	460	40	50



# Cooling Condenser

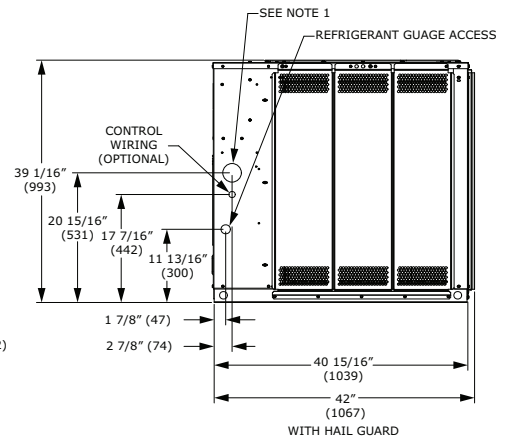
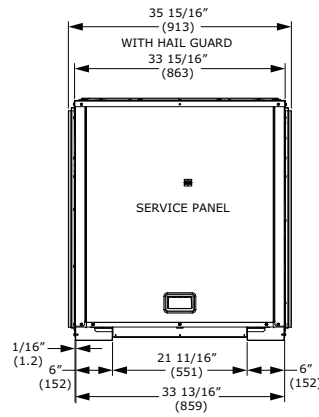
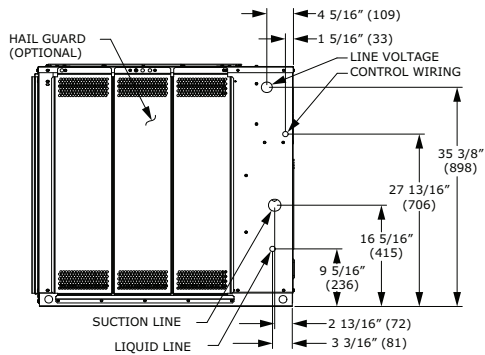
Figure 5. 7.5, 10 ton condensing, single compressor (in inches)



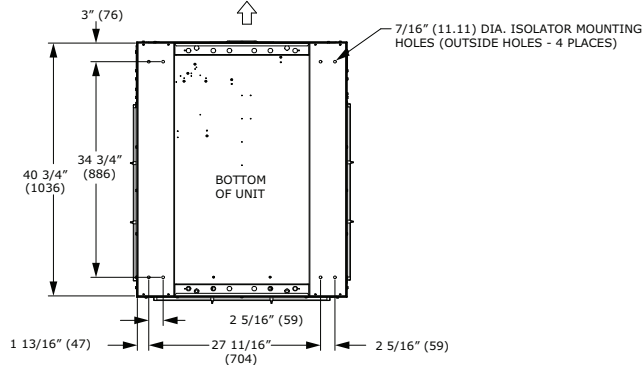
**NOTES:**

1. ACCESS OPENING IS FOR FIELD INSTALLED BAYLOAM ACCESSORY.
2. MINIMUM CLEARANCE FOR PROPER OPERATION IS 36" ( 914.4) FROM WALLS, SHRUBBERY, PRIVACY FENCES ETC. MINIMUM CLEARANCE BETWEEN ADJACENT UNITS IS 72" (1828.8). RECOMMENDED SERVICE CLEARANCE 48" (1219.2)
3. TOP DISCHARGE AREA SHOULD BE UNRESTRICTED FOR 100" (2540) MINIMUM. UNIT SHOULD BE PLACED SO ROOF RUN-OFF WATER OR FALLING SNOW FROM ROOF DOES NOT POUR/FALL DIRECTLY ON UNIT
4. OUTDOOR AIR TEMPERATURE SENSOR OPENING (DO NOT BLOCK OPENING)

SERVICE CLEARANCE  
48" (1219.2) (SEE NOTE 2  
FOR CLEARANCE)



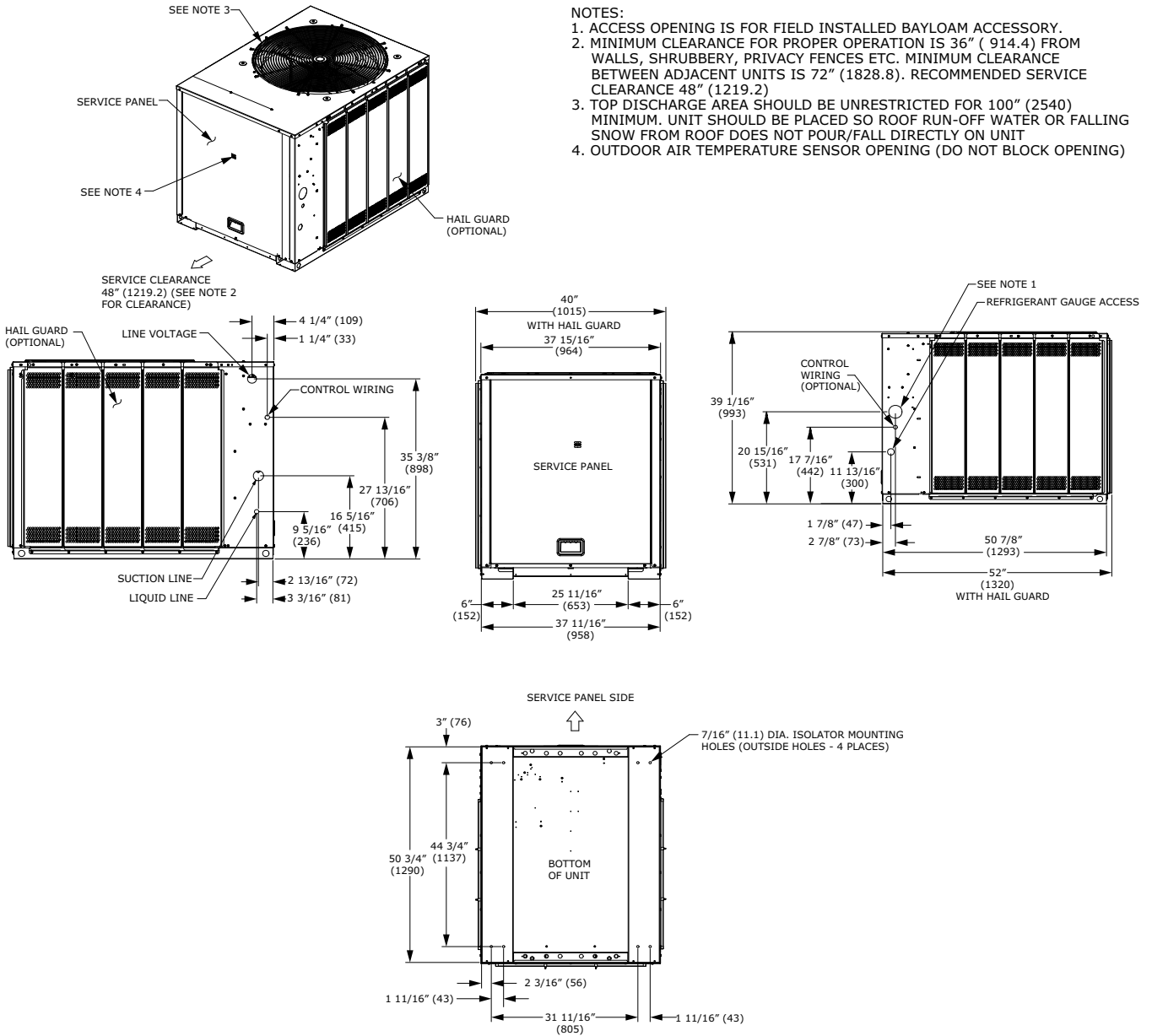
SERVICE PANEL SIDE



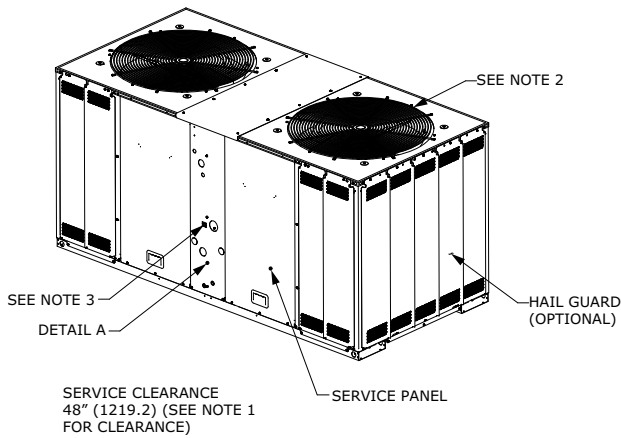


# Cooling Condenser

**Figure 6. 10 ton condensing, manifolded compressor (in inches)**

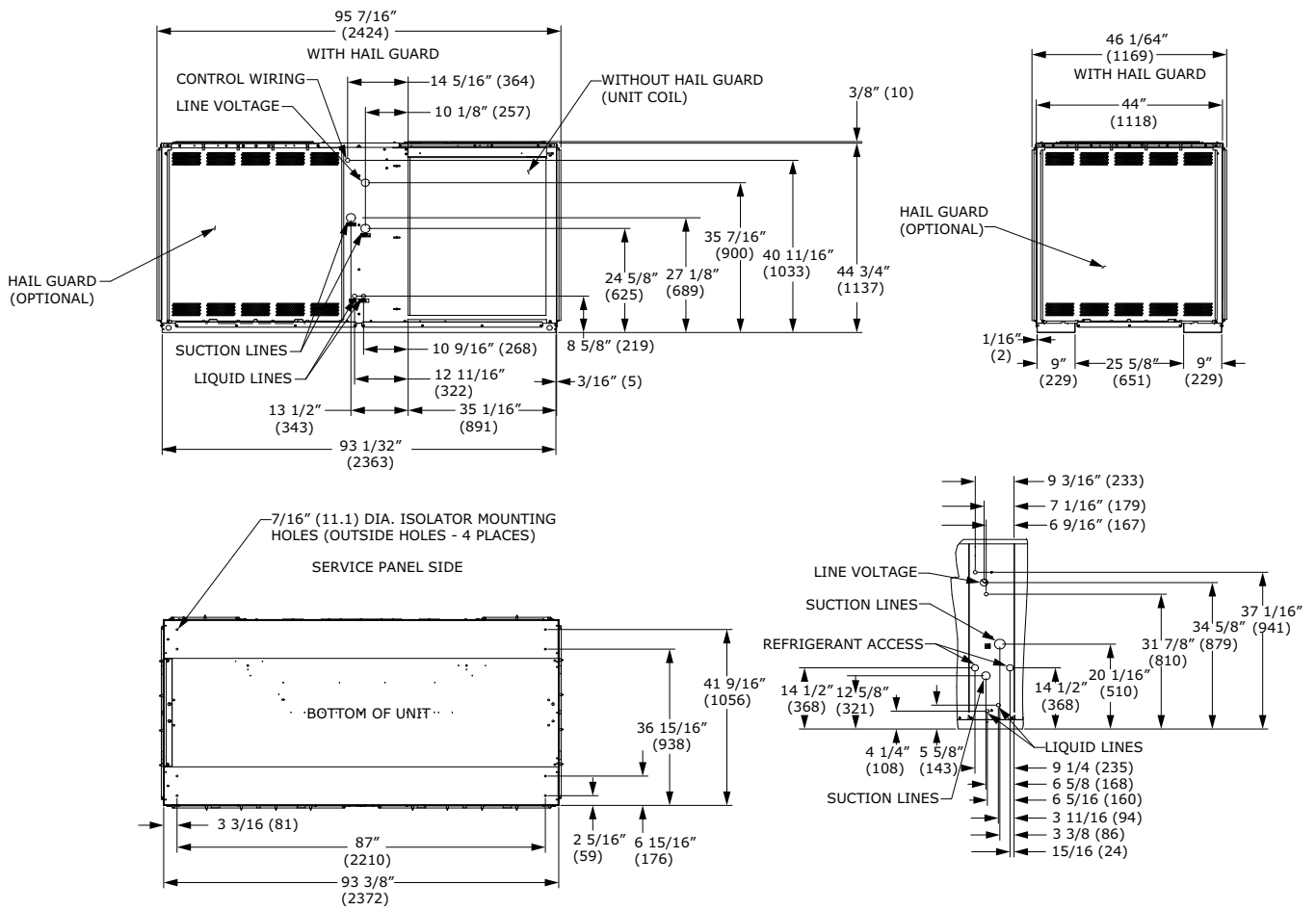


**Figure 7. 15, 20 ton condensing, dual compressor (in inches)**



**NOTES:**

1. MINIMUM CLEARANCE FOR PROPER OPERATION IS 36" ( 914.4) FROM WALLS, SHRUBBERY, PRIVACY FENCES ETC. MINIMUM CLEARANCE BETWEEN ADJACENT UNITS IS 72" (1828.8). RECOMMENDED SERVICE CLEARANCE 48" (1219.2)
2. TOP DISCHARGE AREA SHOULD BE UNRESTRICTED FOR 100" (2540) MINIMUM. UNIT SHOULD BE PLACED SO ROOF RUN-OFF WATER OR FALLING SNOW FROM ROOF DOES NOT POUR/FALL DIRECTLY ON UNIT
3. OUTDOOR AIR TEMPERATURE SENSOR OPENING (DO NOT BLOCK OPENING)





# Weights

## Cooling Condenser

Table 9. TTA R-22 unit and corner weights – lbs (60 Hz)

Tons	Model No.	Shipping Max (lbs)	Net Max (lbs)	Corner Weights			
				1	2	3	4
7.5	TTA0902*A	328	280	73	89	51	67
10	TTA1202*A	405	329	107	84	60	77
15	TTA1802*D	776	661	141	228	112	180
20	TTA2402*D	922	756	180	265	122	190

Figure 8. TTA0902\*A, 1202\*A

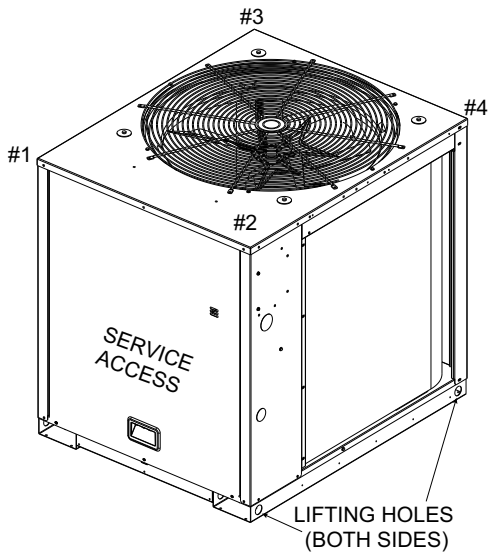
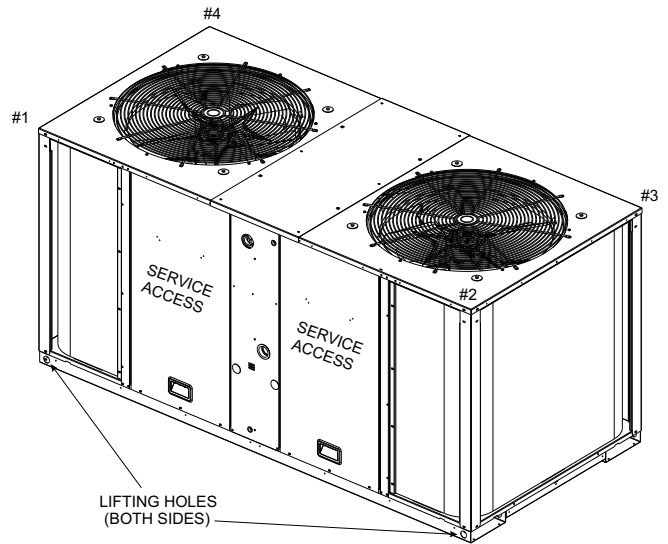


Figure 9. TTA1802\*D, 2402\*D









Notes

---





Trane - by Trane Technologies (NYSE: TT), a global innovator - creates comfortable, energy efficient indoor environments for commercial and residential applications. For more information, please visit [trane.com](http://trane.com) or [tranetechnologies.com](http://tranetechnologies.com).

Trane has a policy of continuous product and product data improvements and reserves the right to change design and specifications without notice. We are committed to using environmentally conscious print practices.

SS-PRC037L-EN 04 Dec 2020  
Supersedes SS-PRC037K-EN (August 2020)

©2020 Trane