

GAGING AND INSPECTION

COMPONENTS FOR CMM APPLICATIONS

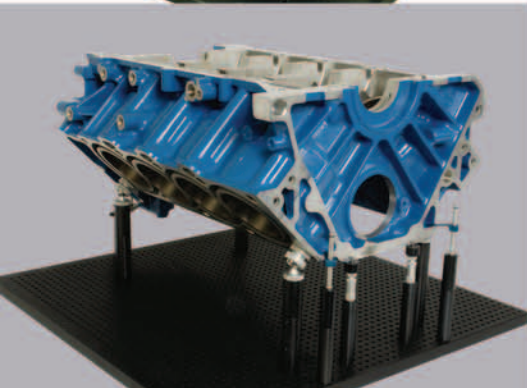
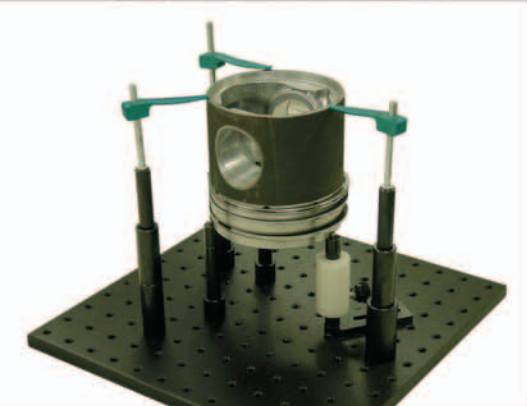
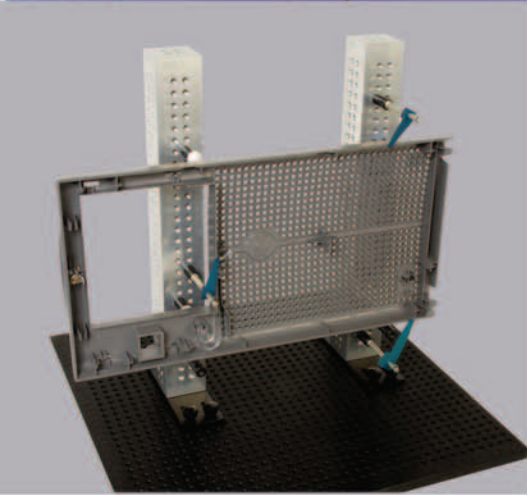
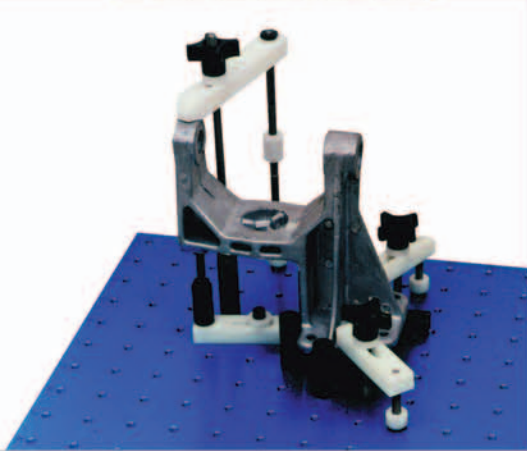
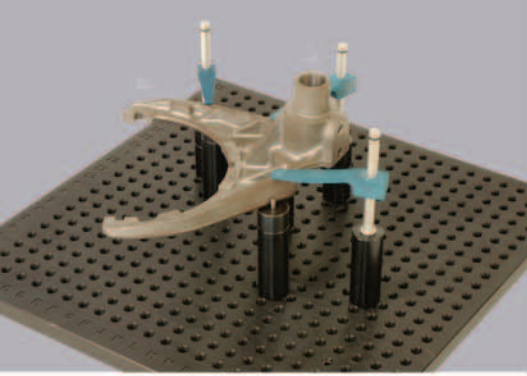

TE·CO[®]
WORKHOLDING

INDEX

CMM Fixturing Systems Overview..... 2

Aluminum Plates 3

Fixturing Towers..... 4

CMM Fixturing Kits 5-7

– Basic Kit 5

– Comprehensive Kit 6

– Magnetic Component Pack..... 7

Soft Touch Clamps..... 7

Small Toggle Clamp with Pad 8

Large Toggle Clamp with Pad 8

T-Handle Spring Stop with Pad 9

Adjustable Positioner..... 9

Standoffs..... 10

Pin Rest 10

Thread Adapter 11

Delrin® Cone 11

Delrin® Holder for
Magnetic Vee Standoffs..... 11

Magnetic Rest Pad..... 12

Magnetic Vee Standoff..... 12

Magnetic Pin Rest..... 12

Magnetic Vee Block 12

Delrin® Height Adjuster 13

Screw Jack..... 13



Adjustable Ball Positioner..... 14

Toggle Pad 14

Swivel Joint Rest..... 14

Knurled Knob with Stud 15

Cap Screw 15

Clamp Support..... 15

Hex Jam Nuts 15

Hardened Flat Washer 15

Plastic Clamp Kit..... 16

Coordinate Measuring
Machine Clamp Kits 17

Tapped Hole Location Gages..... 18

English Tapped Hole
Location Gage Kits 18

Premium Short Shank
Inspection Balls..... 19

Premium Short Shank
Inspection Ball Kit 19

Precision Balls
(Precision Slip Fit Shoulder Balls)..... 19

Tooling Balls
(Shoulder Tooling Balls) 20

Standard Tooling Balls 20

Construction Balls
(Shoulder Construction Balls) 21

Carbide Ball 21

Tooling Ball Cover 21



CMM FIXTURING SYSTEMS

CMM Fixturing System Overview

Our line of CMM fixturing is designed for easy assembly and high repeatability, without the added cost and inconvenience of having to build dedicated fixtures. This system offers a highly accurate and flexible solution for holding parts while probing. A variety of component kits and individual components are available to provide the ability to quickly setup a fixture in a matter of minutes.

The system works by mounting an aluminum fixture plate with tapped holes to the surface plate of your coordinate measuring machine. Build your CMM fixtures by screwing in standoffs or other locating components needed to elevate your part for optimal part access during CMM probing. Once the parts are positioned, simply actuate soft touch clamps over the points of rest fixing the part in position for CMM inspection.

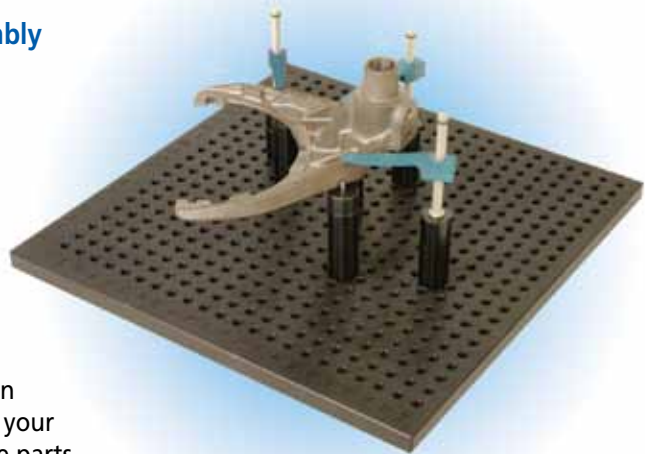

Features of CMM Fixturing System:

- **Aluminum Plates:** Standard plate sizes are offered. TE-CO will quote custom plates to accommodate the measuring ranges of specific models of CMMs. Standard plates are black anodized with 1/4-20 holes on 1/2" and M8 x 1.25 holes on 15mm centers and are alpha numerically labeled so you can build your CMM fixture setups, saving you setup and programming time. Build it once. Program it once.
- **Fixture Towers:** Available with 1/4-20 and M8 x 1.25 tapped holes alpha numerically labeled on each face, ideal for building vertical fixture setups
- **Component Kits:** Plate purchases are not required to purchase component kits or individual components. The basic kit, the comprehensive kit, and the magnetic component pack all come with wooden holders to provide a simple, effective method of storage.
- **Soft Touch Clamp:** This aluminum clamping arm provides the light clamping force ideal for holding parts during CMM probing.
- **Locating Components:** Several diameters and lengths of standoffs and rest pads are available to elevate and position parts without restricting access to them.
- **Magnetic Components:** Magnetic rest pads, vees, and pin rests are available to hold steel and iron parts.
- **Adjustable Components:** A variety of components are available that provide height adjustment, vee alignment, and flexible hole location.
- **Component Thread Size:** Standard components are 1/4-20 and M8 x 1.25 thread size. Alternative thread sizes quoted upon request.

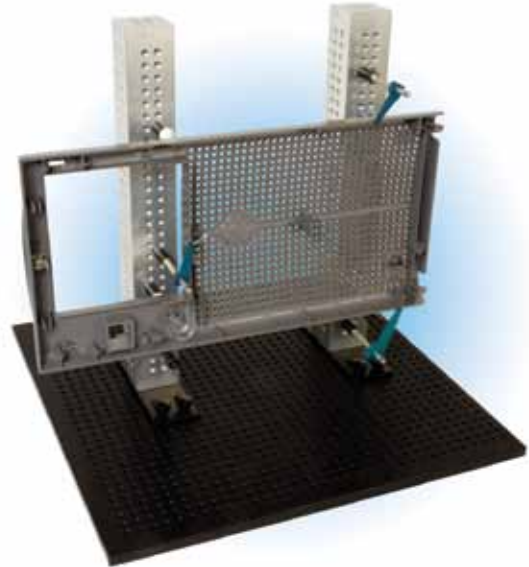

PLATES

Aluminum Fixture Plates

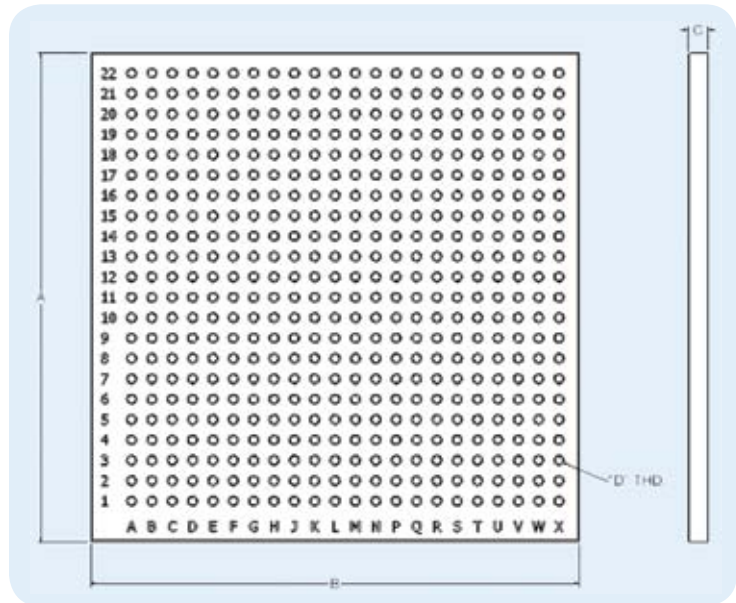

The purpose of the fixture plate is to provide a staging area to build part fixtures. Basic 3-2-1 fixturing holds true for most CMM fixturing applications, although the clamping force required to fixture parts when inspecting with a CMM is significantly less than what is required for machining. Most CMM fixtures require only light pressure clamping to secure the part in a fixed position. Our soft touch clamps are perfect for clamping in CMM fixturing applications.

- Alpha numeric grid pattern
- Black hard coat anodized
- Custom sizes quoted upon request

Inch

Part No.	Length A	Width B	Thickness C	Thread D	Hole Spacing
14312	12"	12"	1/2"	1/4-20	1/2" Centers
14318	18"	18"	1/2"	1/4-20	1/2" Centers
14324	24"	24"	3/4"	1/4-20	1/2" Centers
14330	30"	30"	3/4"	1/4-20	1/2" Centers
14340	28"	40"	3/4"	1/4-20	1/2" Centers

Metric

Part No.	Length A	Width B	Thickness C	Thread D	Hole Spacing
63312	300mm	300mm	13mm	M8 x 1.25	15mm
63318	450mm	450mm	13mm	M8 x 1.25	15mm
63324	600mm	600mm	19mm	M8 x 1.25	15mm

Mounting Information

TE-CO CMM fixture plates can be mounted to the surface plate of your CMM by using step blocks and toe clamps or by drilling mounting holes into the plate which correspond to the inserts in your surface plate.

FIXTURING TOWERS

Fixturing Towers

The purpose of the fixture towers are to provide a vertical part fixturing solution for CMM fixturing applications. More specifically, CMM fixture towers are especially beneficial when you have longer parts that need to be oriented in an upright position between 2 or more towers. Fixture towers are also applicable when you have a relatively flat part and you need to inspect each of its sides. In this application, CMM fixturing towers make it possible to fixture the part(s) vertically in 1 fixture setup reducing fixturing time and the number of programs needed from 2 to 1.

The solution for vertical part fixturing for CMM applications!

- For vertical fixturing
- Includes tapped holes
- Alpha numerically labeled for repeatability



Part #14355 shown

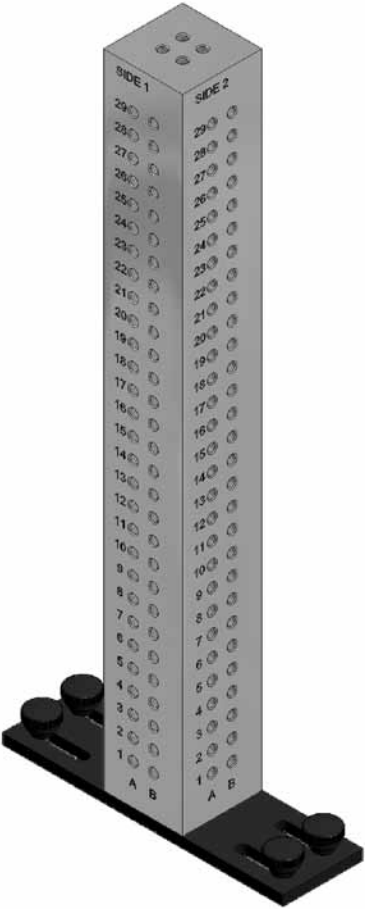
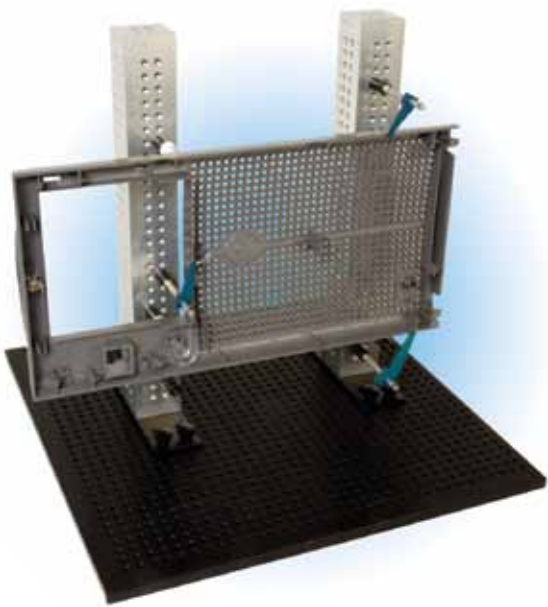

Single Hole Rows – Inch

Part No.	Width A	Height B	Thread Size	Hole Spacing
14350	1"	6"	1/4-20	1/2"
14355	1"	12"	1/4-20	1/2"

Double Hole Rows – Inch

Part No.	Width A	Height B	Thread Size	Hole Spacing
14365	2"	16"	1/4-20	1/2"
14370	2"	20"	1/4-20	1/2"
14375	2"	30"	1/4-20	1/2"

Single Hole Rows – Metric

Part No.	Width A	Height B	Thread Size	Hole Spacing
63350	25mm	150mm	M8 x 1.25	15mm
63355	25mm	300mm	M8 x 1.25	15mm

Double Hole Rows – Metric

Part No.	Width A	Height B	Thread Size	Hole Spacing
63365	50mm	400mm	M8 x 1.25	15mm
63370	50mm	500mm	M8 x 1.25	15mm
63375	50mm	760mm	M8 x 1.25	15mm

CMM FIXTURING KITS

CMM Fixturing Kits

Component kits can be purchased with or without purchasing a plate, and all CMM fixture components contained in the kits are also available individually. The Basic Kit, Comprehensive Kit, and Magnetic Component Pack all come with a wooden holder for convenient storage.

You can also build your own CMM Fixturing Kit. Call us for a quote at 800-543-4071 ,or visit our website at www.te-co.com

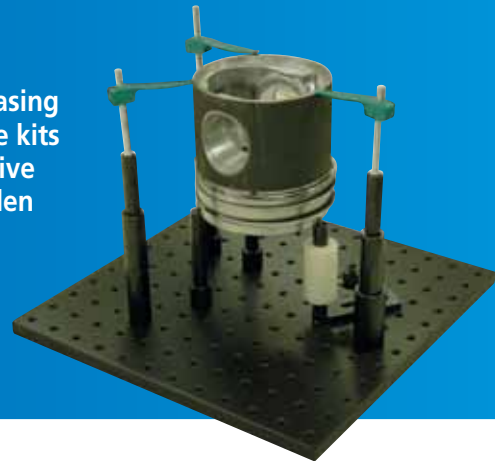

Basic Fixturing Kit

- Designed for clamping non-magnetic parts
- Use with plastic, aluminum and steel

Ideal to combine with the Magnetic Component Pack shown on page 7!



Part No. 14301: 1/4-20 Kit

Item No.	Part No.	Description	Qty.
1	14060	Small Soft Touch Clamp	3
2	14064	Large Soft Touch Clamp	3
3	14034	Large Adjustable Positioner	2
4	14201	Delrin Height Adjuster	1
5	14075	Delrin Cones	3
6	14040	1/2" Dia. x 1/2" Height Pin Rest	3
7	14041	3/4" Dia. x 1/2" Height Pin Rest	3
8	14017	1/2" Dia. x 3/4" Height Standoff	3
9	14018	1/2" Dia. x 1" Height Standoff	6
10	14019	1/2" Dia. x 2" Height Standoff	3
11	14022	3/4" Dia. x 3/4" Height Standoff	3
12	14023	3/4" Dia. x 1" Height Standoff	6
13	14024	3/4" Dia. x 2" Height Standoff	3
14	40091	Wooden Component Holder	1

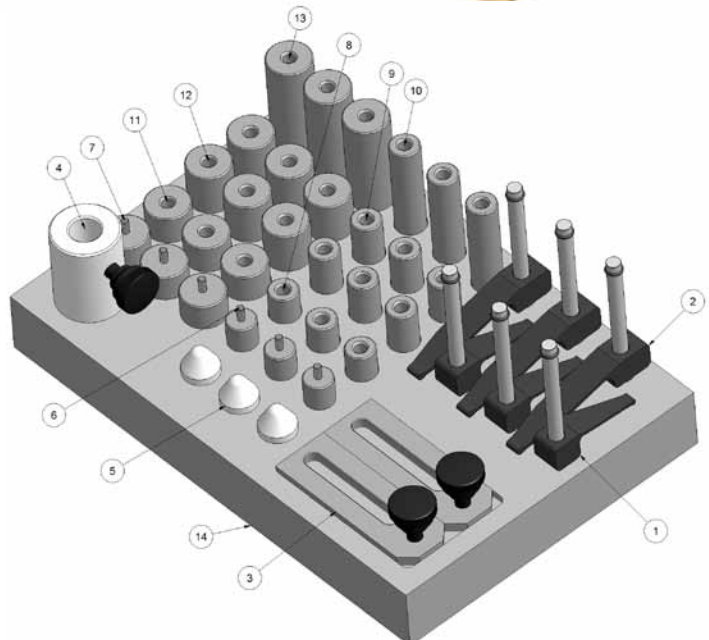

Part No. 63301: M8 x 1.25 Kit

Item No.	Part No.	Description	Qty.
1	63060	Small Soft Touch Clamp	3
2	63064	Large Soft Touch Clamp	3
3	63034	Large Adjustable Positioner	2
4	63201	Delrin Height Adjuster	1
5	63075	Delrin Cone	3
6	63040	13mm Dia. x 25mm Height Pin Rest	3
7	63041	19mm Dia. x 25mm Height Pin Rest	3
8	63017	13mm Dia. x 20mm Height Standoff	3
9	63018	13mm Dia. x 25mm Height Standoff	6
10	63019	13mm Dia. x 50mm Height Standoff	3
11	63022	19mm Dia. x 20mm Height Standoff	3
12	63023	19mm Dia. x 25mm Height Standoff	6
13	63024	19mm Dia. x 50mm Height Standoff	3
14	40089	Wooden Component Holder	1

CMM FIXTURING KITS

Comprehensive Fixturing Kit

- Developed to allow added flexibility
- Use with plastic, aluminum and steel
- Variety of components Provide a quick,

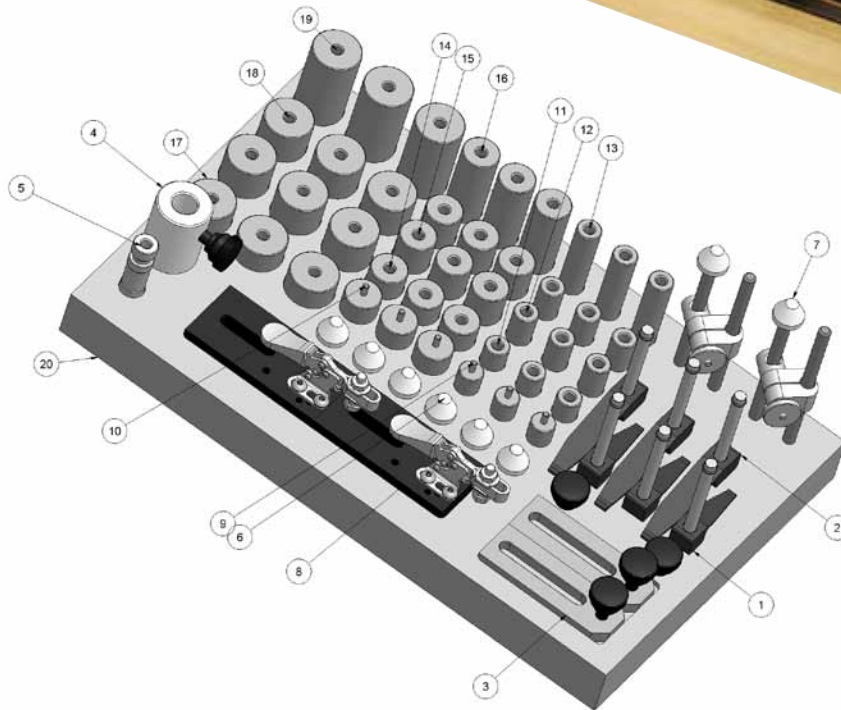

Part No. 14302: 1/4-20 Kit

Item No.	Part No.	Description	Qty.
1	14060	Small Soft Touch Clamp	3
2	14064	Large Soft Touch Clamp	3
3	14034	Large Adjustable Positioner	2
4	14201	Delrin Height Adjuster	1
5	14215	1/2" Dia. Screw Jack	1
6	14075	Delrin Cones	6
7	14082	Swivel Joint Rest	2
8	14158	Small Toggle Clamp with Pad	2
9	14040	1/2" Dia. x 1/2" Height Pin Rest	3
10	14041	3/4" Dia. x 1/2" Height Pin Rest	3
11	14017	1/2" Dia. x 3/4" Height Standoff	3
12	14018	1/2" Dia. x 1" Height Standoff	6
13	14019	1/2" Dia. x 2" Height Standoff	3
14	14022	3/4" Dia. x 3/4" Height Standoff	3
15	14023	3/4" Dia. x 1" Height Standoff	6
16	14024	3/4" Dia. x 2" Height Standoff	3
17	14027	1" Dia. x 3/4" Height Standoff	3
18	14028	1" Dia. x 1" Height Standoff	6
19	14029	1" Dia. x 2" Height Standoff	3
20	40090	Wooden Component Holder	1

Part No. 63302: M8 x 1.25 Kit

Item No.	Part No.	Description	Qty.
1	63060	Small Soft Touch Clamp	3
2	63064	Large Soft Touch Clamp	3
3	63034	Large Adjustable Positioner	2
4	63201	Delrin Height Adjuster	1
5	63005	19mm Dia. Screw Jack	1
6	63075	Delrin Cone	6
7	63282	Swivel Joint Rest	2
8	63158	Small Toggle Clamp with Pad	2
9	63040	13mm Dia. x 25mm Height Pin Rest	3
10	63041	19mm Dia. x 25mm Height Pin Rest	3
11	63017	13mm Dia. x 20mm Height Standoff	3
12	63018	13mm Dia. x 25mm Height Standoff	6
13	63019	13mm Dia. x 50mm Height Standoff	3
14	63022	19mm Dia. x 20mm Height Standoff	3
15	63023	19mm Dia. x 25mm Height Standoff	6
16	63024	19mm Dia. x 20mm Height Standoff	3
17	63027	25mm Dia. x 20mm Height Standoff	3
18	63028	25mm Dia. x 25mm Height Standoff	6
19	63029	25mm Dia. x 50mm Height Standoff	3
20	40093	Wooden Component Holder	1

CLAMPING

Magnetic Component Pack

- Magnets optimize access for probing of steel parts
- Use with steel & iron

Part No. 14303: 1/4-20 Kit

Item No.	Part No.	Description	Qty.
1	14102	1/2" Dia. x 1" Height Magnetic Rest Pad	3
2	14103	3/4" Dia. x 1" Height Magnetic Rest Pad	3
3	14132	1/2" Dia. x 1" Height Magnetic Pin Rest	3
4	14133	3/4" Dia. x 1" Height Magnetic Pin Rest	3
5	14141	1/2" Dia. x 1" Magnetic V Standoff	2
6	14143	1" Dia. x 1" Height Magnetic V Standoff	2
7	40092	Wooden Component Holder	1



Part No. 63303: M8 x 1.25 Kit

Item No.	Part No.	Description	Qty.
1	63102	12.7mm Dia. x 25mm Height Magnetic Rest Pad	3
2	63103	19mm Dia. x 25mm Height Magnetic Rest Pad	3
3	63132	12.7mm Dia. x 25mm Height Magnetic Pin Rest	3
4	63133	19mm Dia. x 25mm Height Magnetic Pin Rest	3
5	14141	12.7mm Dia. x 25.4mm Magnetic V Standoff	2
6	14143	25.4mm Dia. x 25.4mm Magnetic V Standoff	2
7	40092	Wooden Component Holder	1

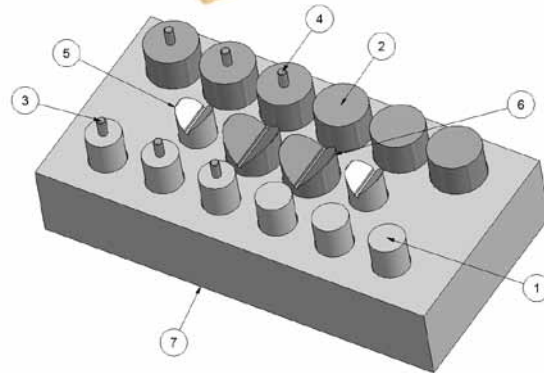

Soft Touch Clamps

- Ideal for light pressure clamping
- Made of aluminum

Actuates with
the press of
a finger!

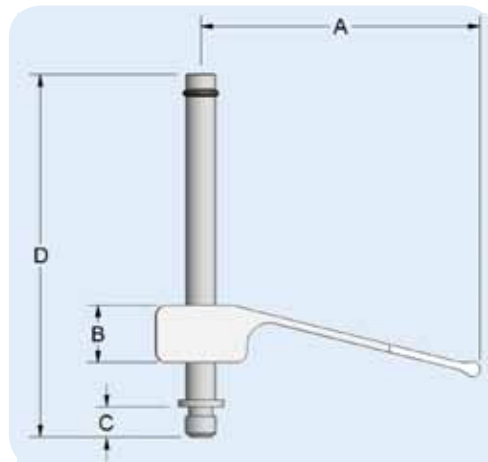
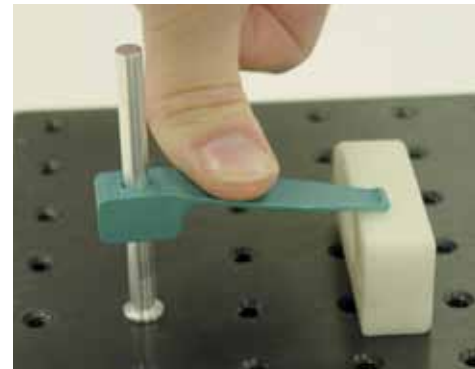
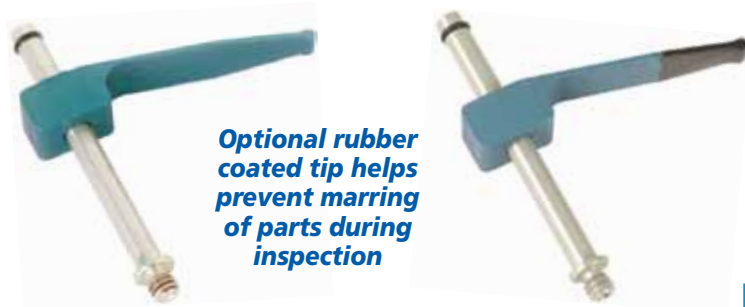

NOTE: Not recommended for machining purposes

Inch

Part No.	Rubber Coated Tip Part No.	A	B	C	D
14060	14050	1.55	.312	.250	3.00
14064	14054	2.31	.477	.250	3.00

Metric

Part No.	Rubber Coated Tip Part No.	A	B	C	D
63060	63050	39mm	8mm	6.37mm	75mm
63064	63054	58.7mm	12mm	6.37mm	75mm

Available in 2 sizes,
with or without
rubber coated tip.



CLAMPING

Small Toggle Clamp with Pad

- Holds parts for probing
- Base adjusts for placement



Knurled knob stud included with all pads

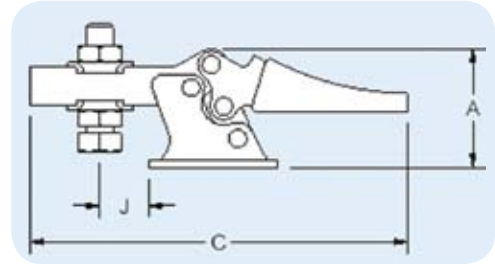
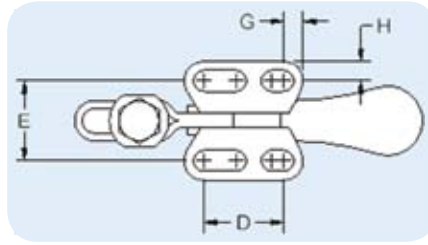
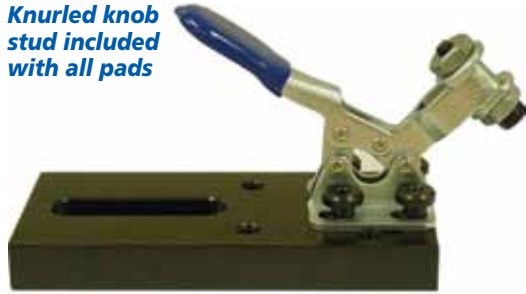

Pad – Inch

Part No.	K	L	M	N	P	Q
14158	3.125	.375	1.50	1.00	.375	.750

Pad – Metric

Part No.	K	L	M	N	P	Q
63158	80mm	6.35mm	38mm	25mm	13mm	19mm

Toggle Clamp (included with pads 14158 & 63158)

Part No.	A	B	C	D	E	G	H	J
N/A	3/4	5/16	2-21/32	5/8	5/8	5/16	5/32	11/16

Large Toggle Clamp with Pad

- Holds parts for probing
- Base adjusts for placement



Knurled knob stud included with all pads

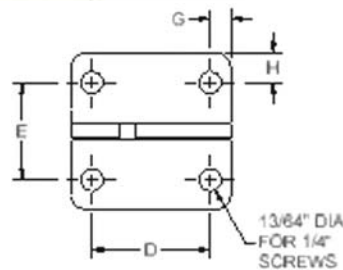

#8-32 UNC - 2B THRU (6) REQ'D.

PROVIDES MOUNTING FOR 53101 - 34105 - 34110

#10-32 UNF - 2B THRU (4) REQ'D.

Pad – Inch

Part No.	K	L	M	N	P	Q
14159	3.125	.375	1.50	1.00	.375	.750

Pad – Metric

Part No.	K	L	M	N	P	Q
63159	80mm	6.35mm	38mm	25mm	13mm	19mm

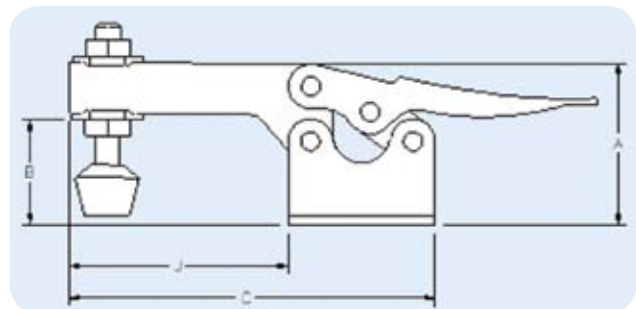

Toggle Clamp (included with pads 14159 & 63159)

Part No.	A	B	C	D	E	G	H	J
N/A	1-1/2	1	5-7/16	1-1/16	7/8	3/16	17/64	2-1/4

STANDOFFS AND LOCATORS

T-Handle Spring Stop with Pad

- Provides horizontal clamping
- T-Handle allows for quick changeover
- Base adjusts for placement



Knurled knob stud included with all pads

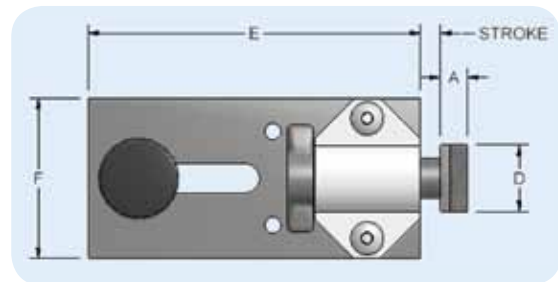
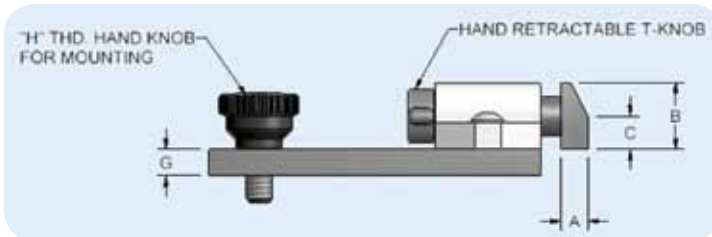
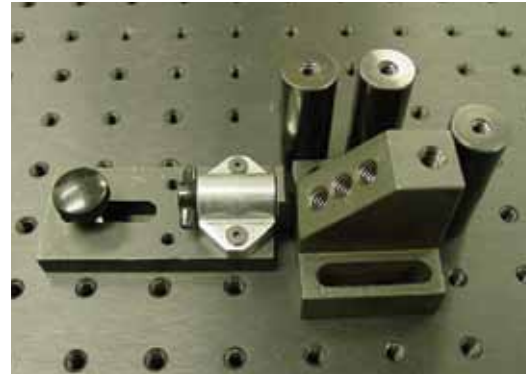

Spring Stop (included with pads)

Part No.	A	B	C	D
N/A	1/4	5/8	5/16	5/8

Pad – Inch

Part No.	E	F	G
14160	3.125	1.50	.375

Pad – Metric

Part No.	E	F	G
63160	80mm	38mm	6.35mm

Adjustable Positioner

- Allows for flexible hole placement
- Includes knurled knob stud to lock in place

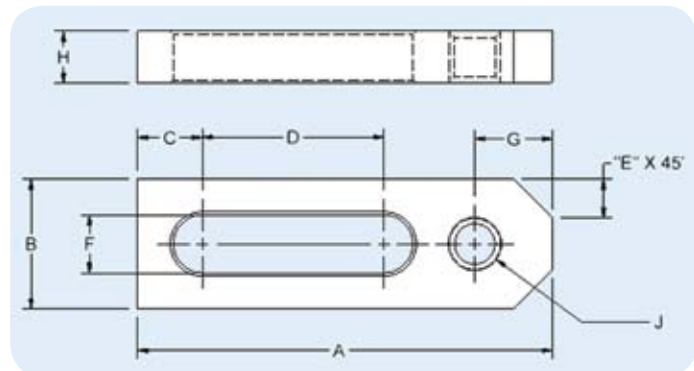

Part No.	Length A	Width B	C	D	E	F	G	H	J
14033	2.00	.625	.313	.875	3/16	.281	.38	.25	1/4-20
14034	3.00	1.00	.313	1.75	1/4	.281	.38	.25	1/4-20
63033	51mm	15mm	8mm	22mm	5mm	8.75mm	5mm	6.4mm	M8x1.25
63034	76mm	25mm	8mm	45mm	6.4mm	8.75mm	6.4mm	6.4mm	M8x1.25

STANDOFFS AND LOCATORS

Standoffs

- Provides resting point to elevate part for probing

3 diameters are available in a variety of heights



1/2" dia.
13mm

3/4" dia.
19mm

1" dia.
25mm

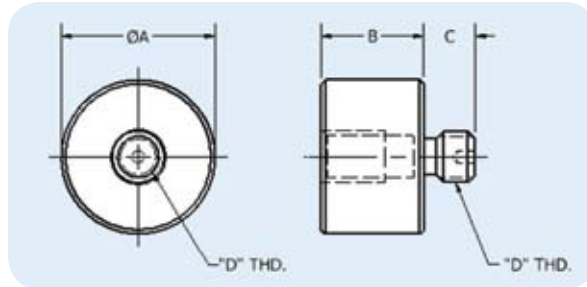

Inch

Part No.	Dia. A	Height B	C	Thread D
14016	.500	.500	1/4"	1/4-20
14017	.500	.750	1/4"	1/4-20
14018	.500	1.00	1/4"	1/4-20
14019	.500	2.00	1/4"	1/4-20
14020	.500	3.00	1/4"	1/4-20

Inch

Part No.	Dia. A	Height B	C	Thread D
14021	.750	.500	1/4"	1/4-20
14022	.750	.750	1/4"	1/4-20
14023	.750	1.00	1/4"	1/4-20
14024	.750	2.00	1/4"	1/4-20
14025	.750	3.00	1/4"	1/4-20

Inch

Part No.	Dia. A	Height B	C	Thread D
14026	1.00	.500	1/4"	1/4-20
14027	1.00	.750	1/4"	1/4-20
14028	1.00	1.00	1/4"	1/4-20
14029	1.00	2.00	1/4"	1/4-20
14030	1.00	3.00	1/4"	1/4-20

Metric

Part No.	Dia. A	Height B	C	Thread D
63016	13mm	15mm	8mm	M8 X 1.25
63017	13mm	20mm	8mm	M8 X 1.25
63018	13mm	25mm	8mm	M8 X 1.25
63019	13mm	50mm	8mm	M8 X 1.25
63020	13mm	75mm	8mm	M8 X 1.25

Metric

Part No.	Dia. A	Height B	C	Thread D
63021	19mm	15mm	8mm	M8 X 1.25
63022	19mm	20mm	8mm	M8 X 1.25
63023	19mm	25mm	8mm	M8 X 1.25
63024	19mm	50mm	8mm	M8 X 1.25
63025	19mm	75mm	8mm	M8 X 1.25

Metric

Part No.	Dia. A	Height B	C	Thread D
63026	25mm	15mm	8mm	M8 X 1.25
63027	25mm	20mm	8mm	M8 X 1.25
63028	25mm	25mm	8mm	M8 X 1.25
63029	25mm	50mm	8mm	M8 X 1.25
63030	25mm	75mm	8mm	M8 X 1.25

Pin Rest

- Provides point of rest and side stop for locating
- Low carbon steel

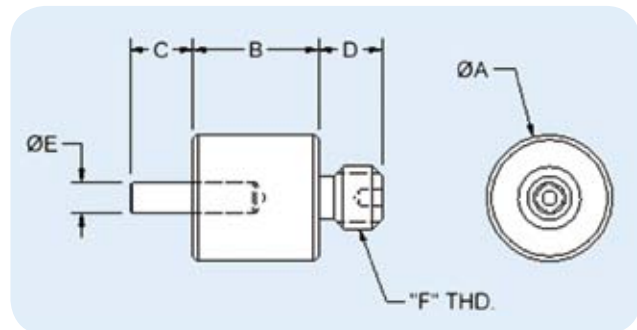

Inch

Part No.	Dia. A	Height B	C	D	E	F
14040	.500	.500	1/4"	1/4"	.125"	1/4-20
14041	.750	.500	1/4"	1/4"	.125"	1/4-20

Metric

Part No.	Dia. A	Height B	C	D	E	F
63040	13mm	25mm	6mm	6.4mm	3mm	M8 x 1.25
63041	19mm	25mm	6mm	6.4mm	3mm	M8 x 1.25

STANDOFFS AND LOCATORS

Thread Adapter

- Converts between 1/4-20 and 5/16-18 systems
- Low carbon steel

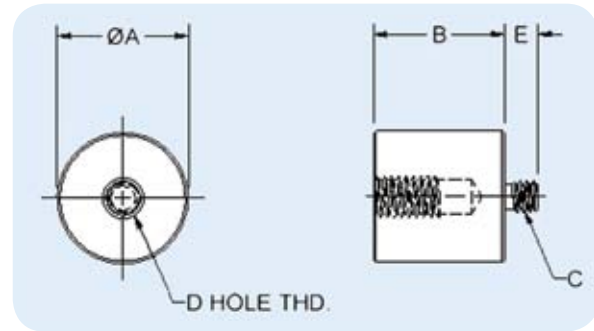

Part No.	A	B	C	D
13085	1.00	1.00	1/4-20	5/16-18
13086	1.00	1.00	5/16-18	1/4-20

Delrin® Cone

- For nesting cylindrical or curved parts
- Delrin offers non-marring attribute
- Also provides resting point without limiting access to part

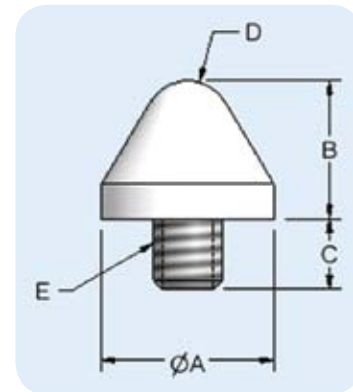

Inch

Part No.	Dia. A	Height B	C	D	E
14075	.625	.500	1/4"	.156	1/4-20

Metric

Part No.	Dia. A	Height B	C	D	E
63075	16mm	13mm	6.4mm	4mm	M8 x 1.25

Delrin® Holder for Magnetic Vee Standoffs

For aligning multiple vees to hold cylindrical parts

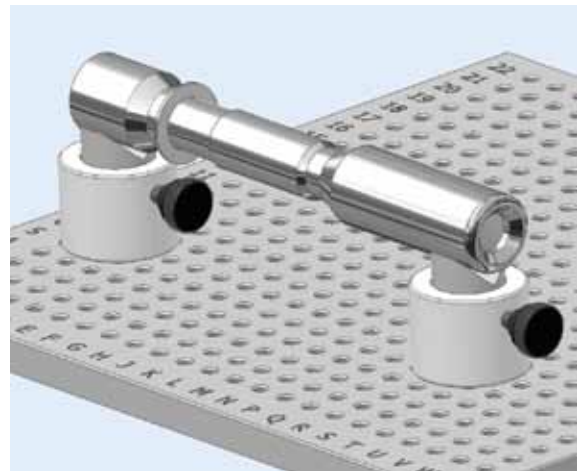

Use with Magnetic Vee shown on page 12.



Inch

Part No.	Outside Dia.	Inside Dia.	Internal Depth	Height	Use With
14162	1.13"	.500"	.625"	1.25"	14141
14164	1.63"	1.00"	.500"	1.25"	14143

Metric

Part No.	Outside Dia.	Inside Dia.	Internal Depth	Height	Use With
63162	28mm	13.5mm	15.8mm	32mm	63141
63163	35mm	19.5mm	15.8mm	32mm	63142
63164	41mm	25.4mm	13mm	32mm	63143

STANDOFFS AND LOCATORS

Magnetic Rest Pad

- For fixturing steel or iron parts
- Magnetic force holds parts during probing

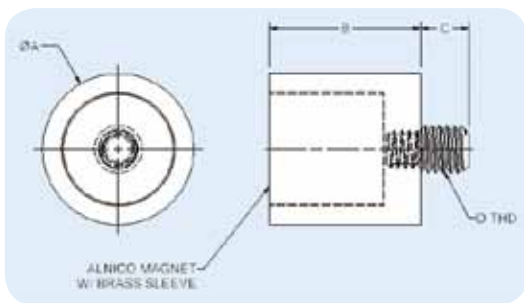

Part No.	Dia. A	Height B	C	D
14101	.250	1.00	1/4"	1/4-20
14102	.500	1.00	1/4"	1/4-20
14103	.750	1.00	1/4"	1/4-20
14104	1.00	1.00	1/4"	1/4-20
63102	12.7mm	25mm	8mm	M8 x 1.25
63103	19mm	25mm	8mm	M8 x 1.25
63104	25.4mm	25mm	8mm	M8 x 1.25

Magnetic Vee Standoff

- For fixturing cylindrical steel or iron parts
- Magnetic force holds parts during probing

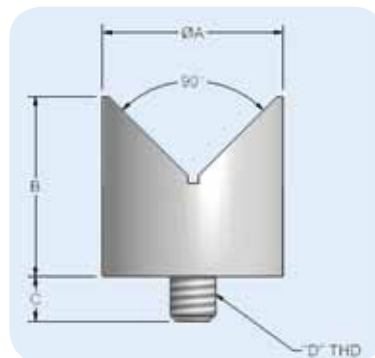

Part No.	Dia. A	Height B	C	D	Holding Capacity Dia.
14141	.500	1.00	1/4"	1/4-20	.125-.625"
14143	1.00	1.00	1/4"	1/4-20	.125-.1.25"
63141	12.7mm	25.4mm	6.4mm	M8 x 1.25	3mm-16mm
63143	25.4mm	25.4mm	6.4mm	M8 x 1.25	3mm-40mm

Magnetic Pin Rest

Locates and holds steel or iron parts during probing.

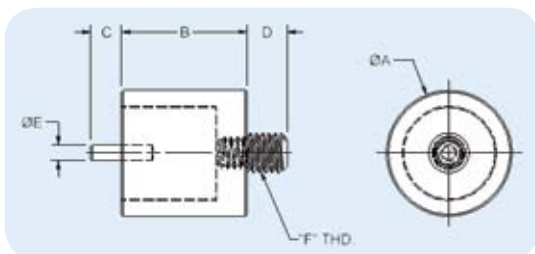

Part No.	Dia. A	Height B	C	D	E	F
14132	.500	1.00	1/4"	1/4"	.125"	1/4"-20
14133	.750	1.00	1/4"	1/4"	.125"	1/4"-20
14134	1.00	1.00	1/4"	1/4"	.125"	1/4"-20
63132	12.7mm	25mm	6mm	8mm	3mm	M8 x 1.25
63133	19mm	25mm	6mm	8mm	3mm	M8 x 1.25
63134	25.4mm	25mm	6mm	8mm	3mm	M8 x 1.25

Magnetic Vee Block

- For holding large cylindrical steel or iron parts
- Includes two cap screws to fasten to plate

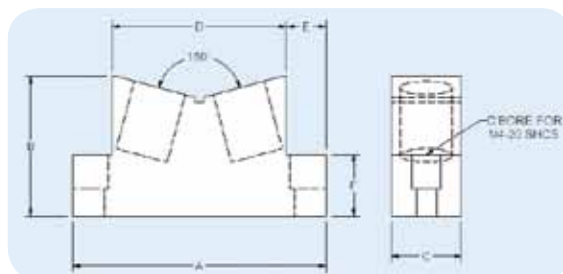

Part No.	A	B	C	D	E	F	Holding Capacity Dia.
14150	3.63"	2"	1"	2.5"	.56"	.68"	2.00-6.25"
63150	92mm	42mm	25mm	63.4mm	14mm	22mm	50mm-159mm

HEIGHT ADJUSTMENT

Delrin® Height Adjuster

- Slips over 1/2" diameter standoffs
- Knurled knob stud quickly tightens for height adjustment
- Standoffs sold separately

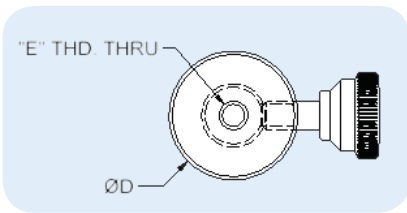
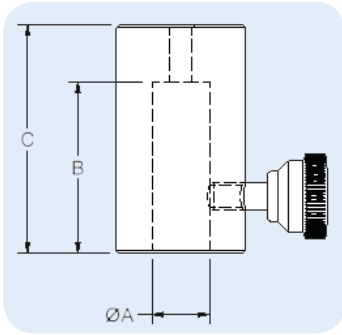

Part No.	A	B	C	D	E
14201	.50	1.50	2"	1.13"	1/4-20
63201	12.7mm	38mm	50mm	28mm	M8 x 1.25

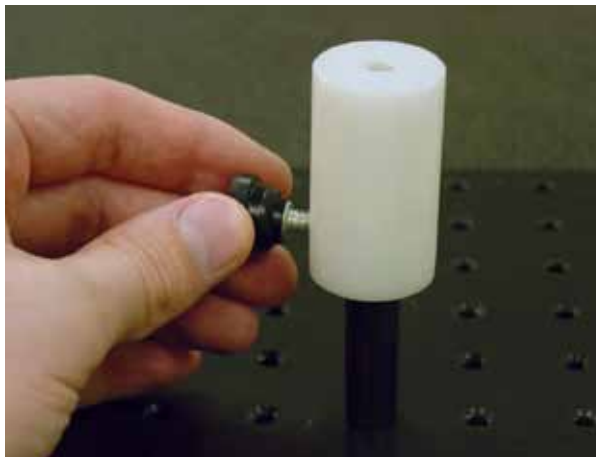

Perform fast and easy height adjustments with Delrin® Height Adjusters from TE-CO!

Screw Jack

- Allows for fine height adjustment during probing
- Made of aluminum

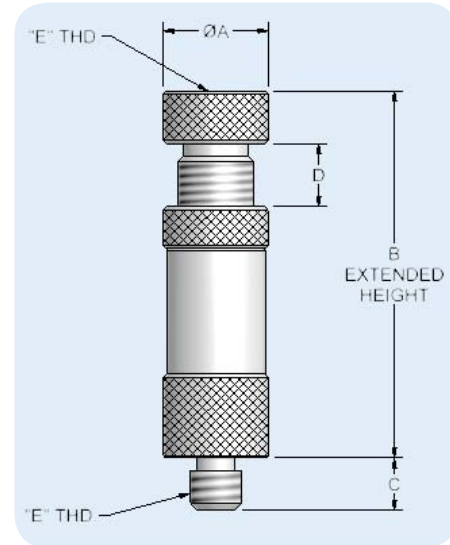

Part No.	A	B	C	D	E	F
14215	.50	1.75"	1/4	.30"	1/4-20	1/4-20
63005	19mm	44.5mm	6.4mm	8mm	M8 x 1.25	M8 x 1.25

www.te-co.com

Information right at your fingertips, anytime you need it!

Downloadable CAD Models

Tradeshaw Information

Featured Products

TE-CO Representatives Locator

Price List

Product Literature

8-Station Baseplate Mounting Information

Adjustable Ball Positioner

- For holding parts at an angle
- Pivots approximately 45° from horizontal in every direction
- Collar easily rotates and tightens on ball at variable angles
- Cylindrical top contains centered 1/4-20 or M8 x 1.25 tapped holes
- Ball is steel; all other components are 6160 aluminum

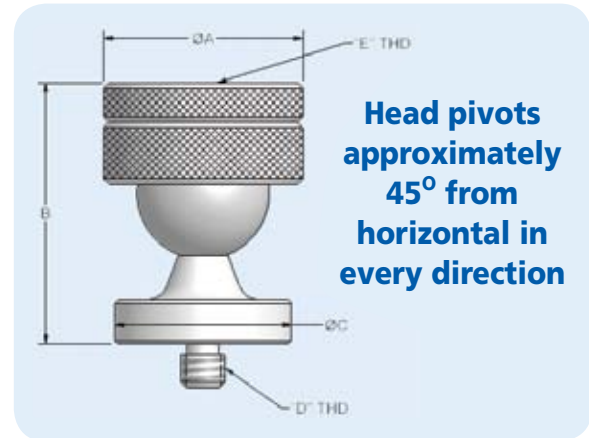

Part No.	A	B	C	D	E
14225	1.125"	1.35"	1"	1/4-20	1/4-20
63225	28.5mm	34mm	25mm	M8 x 1.25	M8 x 1.25

Toggle Pad

- Pad swivels 10° from vertical in all directions
- Assures positive gripping

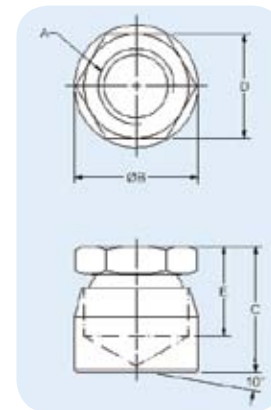

Part No.	A	B	C	D	E
44302	1/4-20	.625	.625	.500	.4063

Swivel Joint Rest

- Rotates 360° from side-to-side and up-and-down
- Arm extends and retracts
- Rotating arm features Delrin cone for positioning a part without marring its surface
- Length of rod = 4.00"

Extendable arm rotates 360° from side-to-side and up-and-down

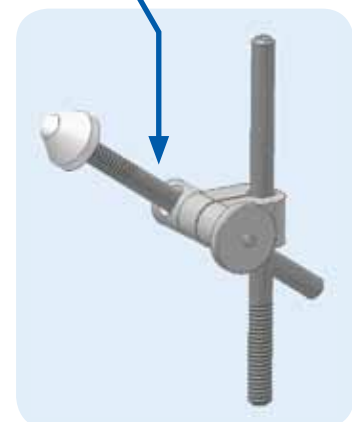

Part No.	Thread Size
14082	1/4-20
63082	M8 x 1.25

PLASTIC CLAMP KIT

Knurled Knob with Stud

For use with:

- Adjustable positioners
- Toggle clamp pads
- Spring stop pads
- Delrin height adjuster
- Magnetic vee holder
- Fixturing towers



Part No.	Thread Size
14203	1/4-20
63203	M8 x 1.25

Multiple uses!

Cap Screw

For use with magnetic vee block (shown on page 92). Two cap screws are included with each magnetic vee block.



Part No.	Thread Size	Thread Length
RSB4503	1/4-20	3/4
63110	M8 x 1.25	20mm

Clamp Support

- Includes washer, spring and shaft collar
- Black oxide finish on washer

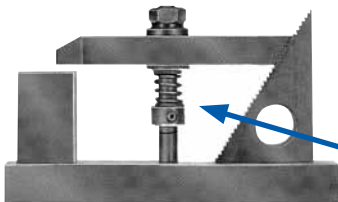

For use with step blocks and clamps

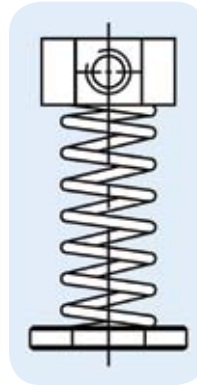

Part No.	Stud Size	Weight (lbs/kit)
50801	1/4	4
50802	5/16/M8	4

Hex Jam Nuts

- Black oxide finish
- High grade alloy steel
- Will outlast ordinary hex jam nuts when used in repetitive operations
- Standard package quantity: 25 pcs.

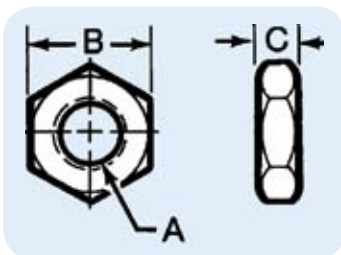

Part No.	Thread A	B	C	Weight (lbs/100pcs)
42201	1/4-20	1/2	11/64	1
63222	M8 x 1.25	9mm	6.5mm	1

Hardened Flat Washer

- Black oxide finish and case hardened
- Material: C1010 Steel
- Many sizes conform to TCMAl standards
- Large quantities quoted upon request

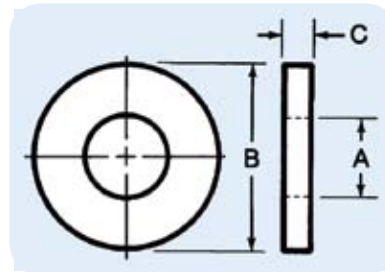

Steel Part No.	Stud Size	A	B	C	Weight (lbs/100pcs)
42601	1/4	9/32	5/8	1/8	1
63602	M8	9mm	19mm	3mm	2

CLAMPING ACCESSORIES

Plastic Clamp Kit

The TE-CO Plastic Clamp Kit is designed exclusively for the CMM inspection, laboratory inspection and gaging applications. The lightweight construction prevents possible damage to granite plates, delicate workpieces, costly inspection fixtures and expensive laboratory instruments.

The plastic construction of the kit helps eliminate damage to painted, plated or finished surfaces while minimizing distortion of plastic or slender shapes. The hand-tightening design allows the user to apply optimum hold down force and prevent possible damage to granite plate inserts. This unique, non-marking clamping kit is designed to meet today's demanding inspection needs.

- Kits are used to properly hold down workpiece during inspection
- Eliminates marring of workpiece surface
- Lightweight construction minimizes part distortion
- Reduces risk of damage to surface plate or CMM table

Kit Contains:

- **24 Steel Studs**
 - 4 each of 2, 3, 4, 5, 6, & 8" lengths
 - Part #12110 does not include 8" length studs
- **12 Plastic Clamps**
 - 4 each of 2.5, 4 & 6" lengths
 - Part #12110 includes 4 each of 2.5", 3.5", & 4.5" lengths (4" & 6" lengths not included)
- **4 coupling nuts**
- **4 plastic hand knobs**
- **4 plastic rest feet**
- **8 washers**
- **1 holder (metal tray)**

Materials:

- Clamps, rest feet: Nylon 101
- Studs, coupling nuts and washers: Steel

Plastic components eliminate marring of the workpiece surface and minimize part distortion



Individual components are available upon request

English

Part No.	Thread Size
*12110	1/4-20
12111	5/16-18
12112	3/8-16

*Composition differs slightly

Metric

Part No.	Thread Size
12210	8mm
12211	10mm
12212	12mm

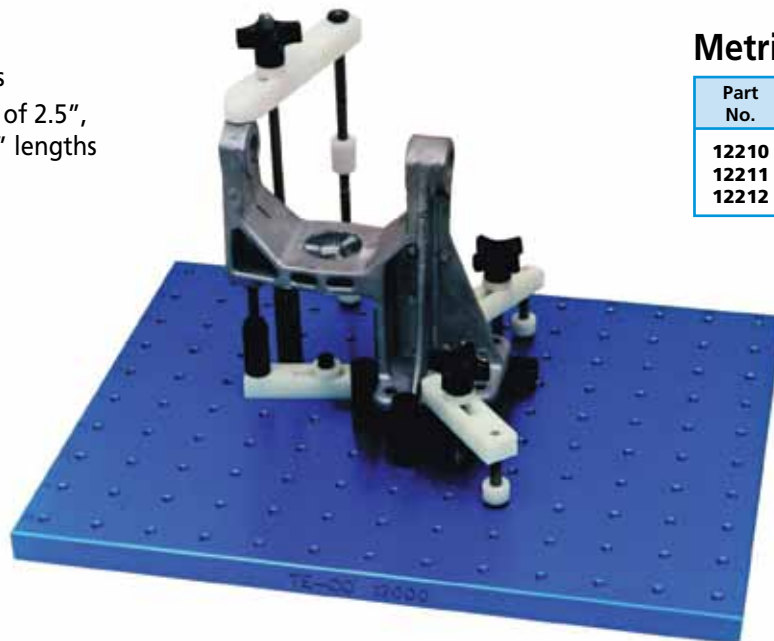

Plastic clamps are NOT recommended for machining purposes

CLAMPING

Coordinate Measuring Machine Clamp Kits

- Kits are used to properly hold down workpiece during workpiece inspection. see individual components.

Optional T-Slot Nuts available (see charts at bottom of page).



Kits available in both English and Metric!

English Coordinate Measuring Machine Clamp Kits

Kit Contains:

- 8 Coupling Nuts
- 8 Flange Nuts
- 2 Serrated End Clamps: 2-1/2" O.A.L.
- 2 Serrated End Clamps: 4" O.A.L.
- 2 Serrated End Clamps: 6" O.A.L.
- 2 Steel Step Blocks (Max. Height 1-5/8")
- 2 Steel Step Blocks (Max. Height 2-1/2")
- 2 Steel Step Blocks (Max. Height 6")
- 24 Studs: 4 Each of 3", 4", 5", 6", 7" & 8" long
- 1 Holder

Part No.	Stud Size	Step Blocks (2 each)	Serrated End Clamps (2 each)
12104	1/4-20	40102	30501
		40103	30502
		40104	30503
12105	5/16-18	40102	30501
		40103	30502
		40104	30503
12106	3/8-16	40102	30501
		40103	30502
		40104	30503

Optional T-Slot Nuts

Part No.	Stud Size	Table T-Slot English	Table T-Slot Metric
41402	1/4-20	3/8	10mm
41403	5/16-18	3/8	10mm
41404	3/8-16	7/16	12mm

Metric Coordinate Measuring Machine Clamp Kits

Kit Contains:

- 8 Coupling Nuts
- 8 Flange Nuts
- 2 Serrated End Clamps: 64mm O.A.L.
- 2 Serrated End Clamps: 102mm O.A.L.
- 2 Serrated End Clamps: 152mm O.A.L.
- 2 Steel Step Blocks (Max. Height 41mm)
- 2 Steel Step Blocks (Max. Height 64mm)
- 2 Steel Step Blocks (Max. Height 152mm)
- 24 Studs: 4 Each of 80mm, 110mm, 140mm, 155mm, 175mm & 200mm long
- 1 Holder

Part No.	Stud Size	Step Blocks (2 each)	Serrated End Clamps (2 each)
12205	M8 x 1.25	40102	30501
		40103	30502
		40104	30503
12206	M10 x 1.50	40102	30501
		40103	30502
		40104	30503
12207	M12 x 1.75	40102	30504
		40103	30505
		40104	30506

Optional T-Slot Nuts

Part No.	Stud Size	Table T-Slot English	Table T-Slot Metric
61403	M8 x 1.25	10mm	7/16
61404	M10 x 1.50	12mm	1/2
61406	M12 x 1.75	14mm	9/16

CMM FIXTURING KITS

Tapped Hole Location Gages

- Material:
 - Body: 52100 Steel
 - Collar: 12L14 Steel
- Black oxide finish on collar only
- Two piece construction
- Use to accurately measure the distance between two tapped holes in a workpiece
- Shaft size is the same diameter on all gages to simplify calculation of the hole spread
 - All diameters are concentric within .0002 T.I.R.
- English:
 - Thread Class: 3A
 - Left-hand thread, helicoil, or other non-standard gages quoted upon request
- Metric:
 - Thread Class: 6G
 - ISO metric fine pitch thread, left-hand thread, helicoil, or other non-standard gages quoted upon request



Part No.	Thread A	Dia. B	Dia. C*	D	E	Weight (lbs/100pcs)
10321	6-40	5/16	.2500	7/8	1/4	1
10309	10-32	5/16	.2500	7/8	1/4	1
10310	1/4-28	3/8	.2500	1	3/8	2
10311	5/16-24	1/2	.2500	1	3/8	3
10312	3/8-24	1/2	.2500	1	3/8	3
10313	7/16-20	7/8	.2500	1	3/8	4
10314	1/2-20	7/8	.2500	1	3/8	6
10315	5/8-18	7/8	.2500	1	3/8	6

*C Diameter: +.0002/-0.0000

UNC Sizes

Part No.	Thread A	Dia. B	Dia. C*	D	E	Weight (lbs/100pcs)
10317	2-56	5/16	.2500	7/8	5/16	1
10318	4-40	5/16	.2500	7/8	5/16	1
10319	5-40	5/16	.2500	7/8	5/16	1
10320	6-32	5/16	.2500	7/8	5/16	1
10322	8-32	5/16	.2500	7/8	5/16	1
10301	10-24	5/16	.2500	7/8	5/16	1
10302	1/4-20	3/8	.2500	1	3/8	3
10303	5/16-18	1/2	.2500	1	3/8	3
10304	3/8-16	1/2	.2500	1	3/8	3
10305	7/16-14	7/8	.2500	1	3/8	4
10306	1/2-13	7/8	.2500	1	3/8	6
10307	5/8-11	7/8	.2500	1	3/8	6
10330	3/4-10	1	.2500	1-1/8	1/2	12

*C Diameter: +.0002/-0.0000

Metric Sizes

Part No.	Thread A	Dia. B	Dia. C*	D	E	Weight (lbs/100pcs)
11101	M1.6 x .35	7.95	6.35	22	6.35	0.90
11103	M2.0 x .40	7.95	6.35	22	6.35	1.00
11105	M2.5 x .45	7.95	6.35	22	6.35	1.00
11107	M3.0 x .50	7.95	6.35	22	6.35	1.00
11109	M4.0 x .70	7.95	6.35	22	6.35	1.00
11111	M5.0 x .80	9.53	6.35	22	6.35	1.40
11113	M6.0 x 1.00	9.53	6.35	22	6.35	1.50
11121	M8.0 x 1.25	12.7	6.35	28	12.70	2.70
11123	M10 x 1.50	12.7	6.35	28	12.70	4.50
11125	M12 x 1.75	22.23	6.35	28	12.70	5.50
11127	M16 x 2.0	22.23	6.35	28	12.70	7.50
11129	M20 x 2.50	25.4	6.35	28	12.70	12.00

*C Diameter: +.0002/-0.0000

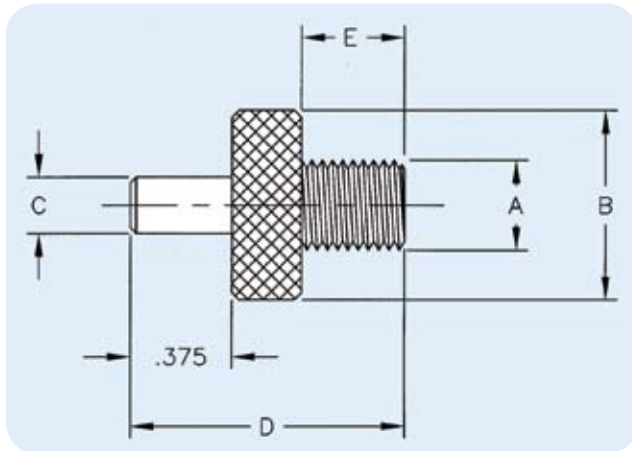

English Tapped Hole Location Gage Kits

- Each kit includes a wooden storage box
- Special kits can be assembled to meet your requirements.



UNF Kit

Part No.	Weight (lbs/kit)	Thread	2 Each
10316	1	10-32	10309
		1/4-28	10310
		5/16-24	10311
		3/8-24	10312
		7/16-20	10313
		1/2-20	10314
		5/8-18	10315

UNC Kit

Part No.	Weight (lbs/kit)	Thread	2 Each
10308	1	10-24	10301
		1/4-20	10302
		5/16-18	10303
		3/8-16	10304
		7/16-14	10305
		1/2-13	10306
		5/8-11	10307

Part No.	Weight (lbs/kit)	Thread	2 Each
10323	1	2-56	10317
		4-40	10318
		5-40	10319
		6-32	10320
		6-40	10321
		8-32	10322

TOOLING BALLS

Premium Short Shank Inspection Balls

Used as reference points for inspection applications in conjunction with Coordinate Measuring Machines to accurately measure the workpiece.

- Material: 8620 Steel
- Case hardened
- Concentricity of ball to shank: .0001 T.I.R.



One-piece construction

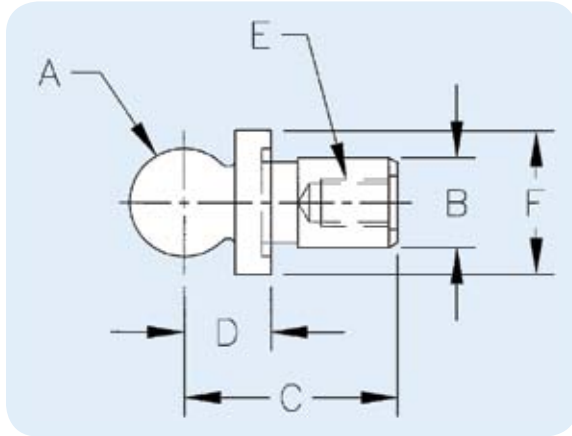

Part No.	Dia. A*	Dia. B**	C	D***	Thread E	Dia. F	Weight (lbs/100pcs)
10601	0.2500	0.1247	0.58	.2000		1/4	1
10602	0.3750	0.1872	0.74	.3000		3/8	1
10603	0.3750	0.3125	0.74	.3000	8-32	1/2	3
10604	0.5000	0.2497	0.63	.3125	6-32	1/2	3
10605	0.5000	0.2497	0.93	.4000	6-32	1/2	3
10606	0.5000	0.2497	0.88	.5000	6-32	1/2	3
10607	0.5000	0.3750	1.31	.3750	10-24	5/8	6
10608	0.6250	0.3122	1.08	.4500	8-32	5/8	6
10609	0.6250	0.3750	1.42	.4500	10-24	5/8	7
10610	0.6875	0.3750	1.47	.5000	10-24	3/4	9
10611	0.7500	0.3750	1.53	.5625	10-24	3/4	13
10612	1.0000	0.5000	1.64	.7000	10-24	1	25

*A Diameter: +.0000/-.0002

**B Diameter: +.0000/-.0002

***D: +/- .0002

Premium Short Shank Inspection Ball Kit

- Each kit includes a wooden storage box
- Special kits can be assembled to meet your requirements.

Part No.	2 Each	
10613	10601	10605
	10602	10606
	10603	10608
	10604	



Precision Balls (Precision Slip Fit Shoulder Balls)

Used as reference points for inspection applications in conjunction with Coordinate Measuring Machines to accurately measure the workpiece.

- Hardened and ground steel (440 Stainless)
- Concentricity of ball to shank: .0002 T.I.R.

Two-piece construction

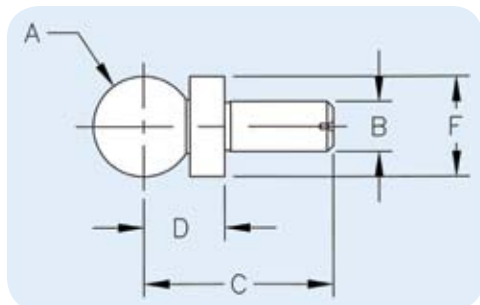

Part No.	Dia. A*	Dia. B**	C	D***	Dia. F	Weight (lbs/100pcs)
10850	0.25000	0.1247	9/16	.2000	1/4	1
10851	0.37500	0.1872	3/4	.3000	3/8	1
10852	0.50000	0.2497	15/16	.4000	1/2	3
10853	0.62500	0.3122	1-1/16	.4500	5/8	6
10854	0.75000	0.3747	1-1/4	.5000	3/4	10
10855	0.87500	0.4372	1-7/16	.6000	7/8	7
10856	1.00000	0.4997	1-5/8	.7000	1	24

*A Diameter: +/- .0005

**B Diameter: +.0000/-.0002

***D: +/- .0002

INSPECTION BALLS

Tooling Balls (Shoulder Tooling Balls)

Used as reference points for inspection applications in conjunction with Coordinate Measuring Machines to accurately measure the workpiece

- Hardened and ground steel (8620 steel)
- Concentricity of Ball to Shank: .0002 T.I.R.



One-piece construction

Slip Fit

Part No.	Dia. A*	Dia. B**	C	D***	Dia. F	Weight (lbs/100pcs)
10801	0.2500	0.1250	9/16	.2000	1/4	1
10802	0.3750	0.1875	3/4	.3000	3/8	1
10803	0.5000	0.2500	15/16	.4000	1/2	3
10804	0.5000	0.2500	1-3/8	.5000	1/2	4
10805	0.7500	0.3750	1-1/4	.5000	3/4	10

*A Diameter: $\pm .0002$

**B Diameter: $+ .0000 / - .0004$

***D: $\pm .0002$

Press Fit

Part No.	Dia. A*	Dia. B**	C	D***	Dia. F	Weight (lbs/100pcs)
10901	0.2500	0.1253	9/16	.2000	1/4	1
10902	0.3750	0.1878	3/4	.3000	3/8	1
10903	0.5000	0.2503	15/16	.4000	1/2	3
10904	0.5000	0.2503	1-3/8	.5000	1/2	4
10905	0.7500	0.3753	1-1/4	.5000	3/4	10

*A Diameter: $\pm .0002$

**B Diameter: $+ .0003 / - .0000$

***D: $\pm .0002$

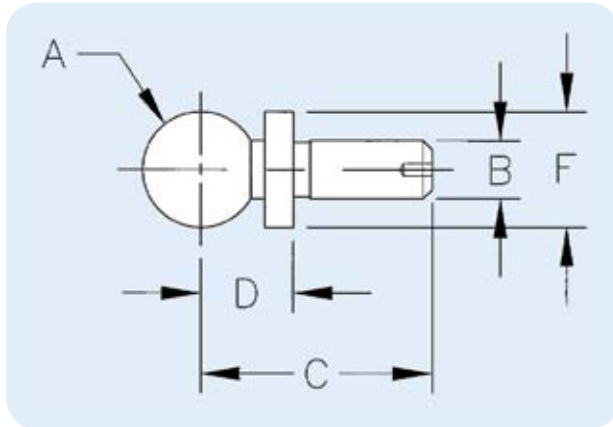

Standard Tooling Balls

Used as reference points for inspection applications in conjunction with Coordinate Measuring Machines to accurately measure the workpiece

- Hardened and ground steel (8620 steel)
- Concentricity of Ball to Shank: .0002 T.I.R.



One-piece construction

Slip Fit

Part No.	Dia. A*	Dia. B**	C	Weight (lbs/100pcs)
11201	0.2500	0.1250	9/16	1
11202	0.3750	0.1875	3/4	1
11203	0.5000	0.2500	15/16	3
11204	0.5000	0.2500	1-1/2	3
11205	0.5000	0.3750	1-1/2	8

*A Diameter: $\pm .0002$

**B Diameter: $+ .0000 / - .0004$

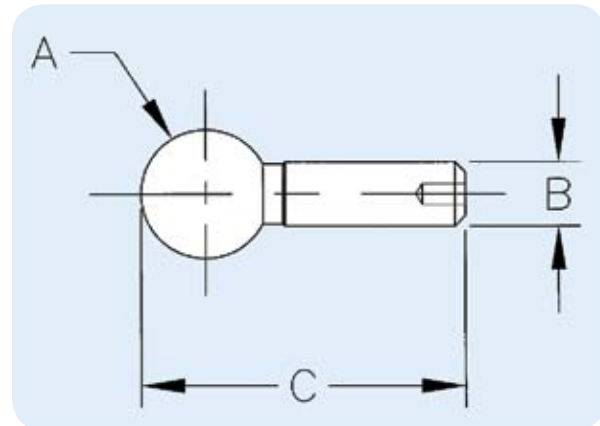

WISE ACCESSORIES

Construction Balls (Shoulder Construction Balls)

Used as reference points for inspection applications in conjunction with Coordinate Measuring Machines to accurately measure the workpiece

- Hardened and ground steel (8620 steel)
- Concentricity of ball to shank: .0002 T.I.R.



One-piece construction

English

Part No.	Dia. A*	Dia. B**	C	D***	Dia. F	Weight (lbs/100pcs)
11001*	.5000	.2500	5/8	0.3125	1/2	3
11002	.5000	.2500	5/8	0.3125	1/2	3

*A Diameter: $\pm .0002$

**B Diameter: $+ .0000 / - .0004$

***D: $\pm .0002$

* 6-32 UNC-2B x 3/16 deep tapped shank as shown.

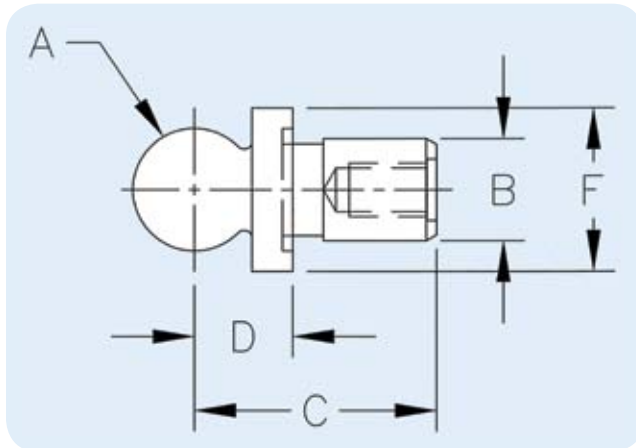

Metric

Part No.	Dia. A*	Dia. B**	C	D***	Dia. F	Weight (lbs/100pcs)
11020	6mm	3mm	16mm	6mm	6mm	1
11021	10mm	5mm	20mm	10mm	10mm	3
11022	12mm	6mm	22mm	12mm	12mm	3

*A Diameter: $\pm .005$ mm

**B Diameter: $+ .000 / - .010$ mm

***D: $\pm .005$

Carbide Ball

Used as reference points for inspection applications in conjunction with Coordinate Measuring Machines to accurately measure the workpiece

- Material:
 - Ball: Carbide
 - Shank: 440 Stainless
- Weight per 100 pcs.: less than one pound
- Concentricity of ball to shank: .0002 T.I.R.



Two-piece construction

Part No.
11070

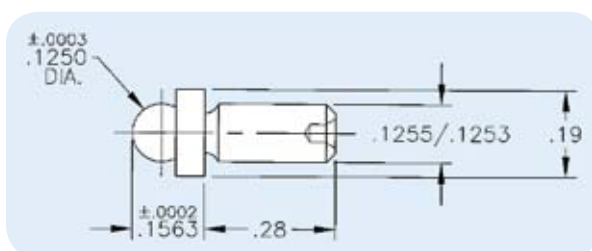

Tooling Ball Cover

- Protects tooling and inspection balls from damage between operations.
- Low cost solution to protect your tooling ball investment
- Made of a durable, high impact resistant Polymer
- Mounts over .875" diameter or smaller tooling ball directly into jig fixture with two number 10 screws



Part No.	Max. Tooling Ball Size
10600	.875" Dia. Ball

CMM Fixturing with Flexibility and Modularity

TE-CO's line of CMM fixturing is designed for easy assembly and high repeatability, eliminating the need to build dedicated fixtures. This system offers a highly accurate and flexible solution for holding parts while probing.

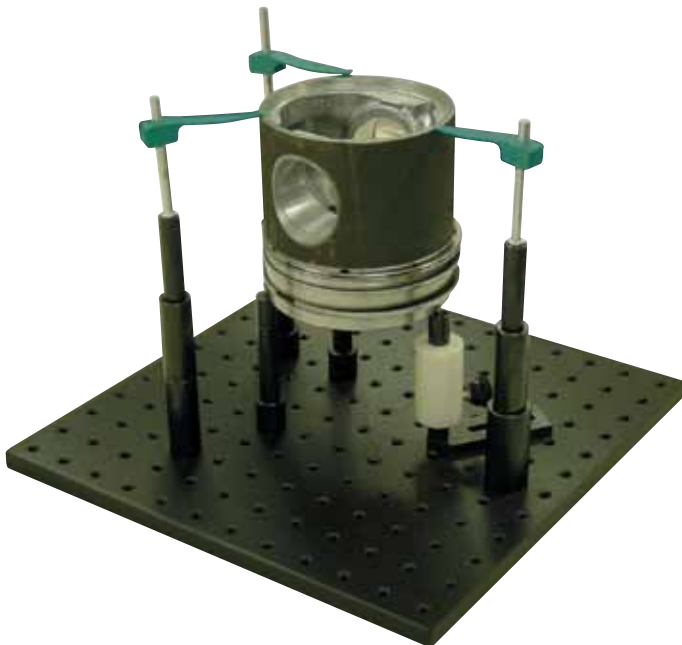
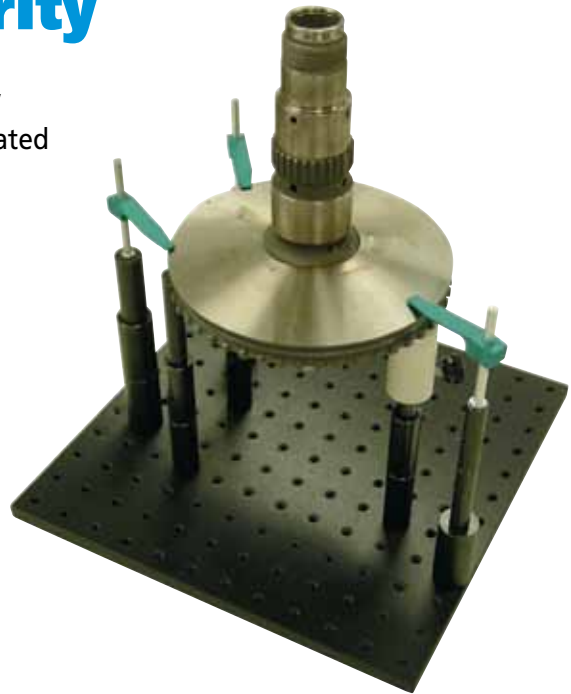
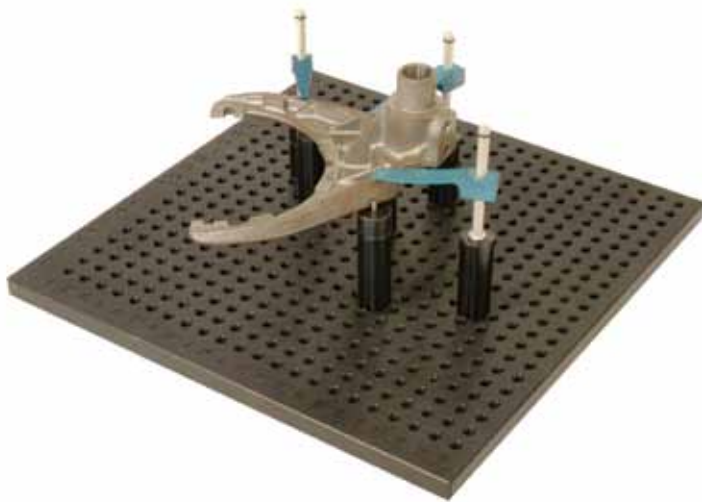

**Find out more at
www.te-co.com**

DON'T FORGET THE WORKHOLDING!

**TE-CO IS THE COMPLETE SOURCE FOR
ALL YOUR WORKHOLDING NEEDS!**

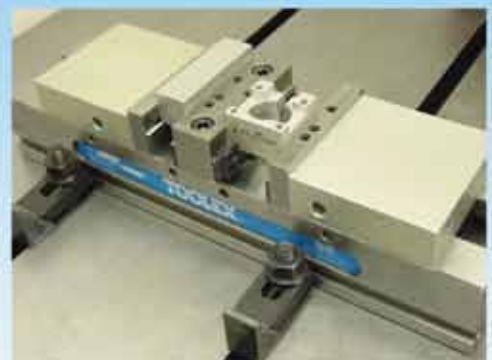
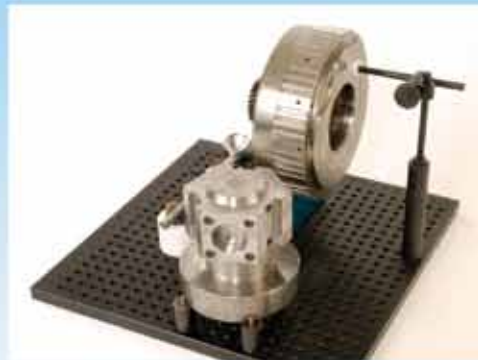
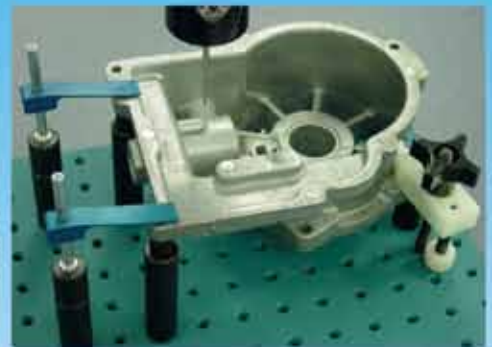

**Clamping Kits • Jig & Fixture Components
Vises & Accessories • CMM Fixturing**

TE·CO
WORKHOLDING

www.te-co.com

800-543-4071 www.te-co.com 109 Quinter Farm Rd. Union, OH 45322

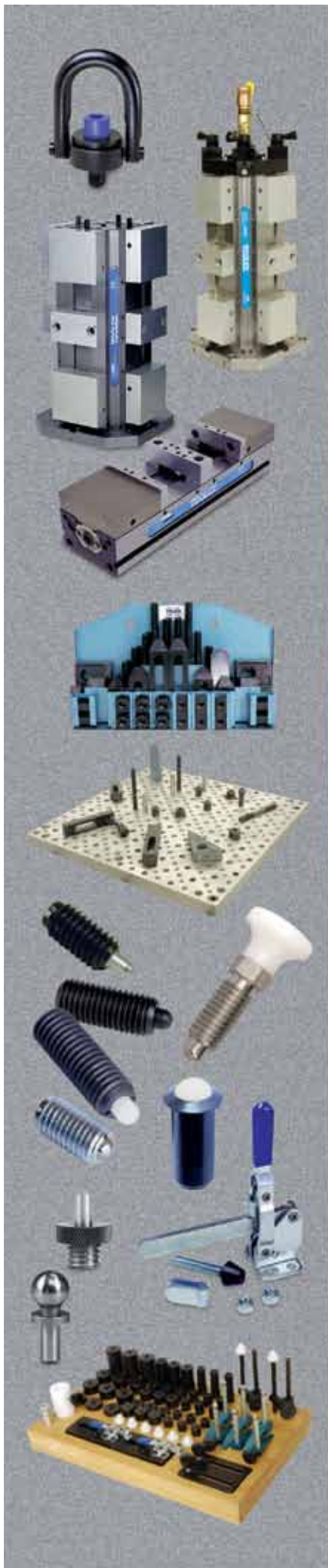

te-co.com

The COMPLETE SOURCE for Workholding Products



Featuring detailed product information, news and events, downloadable CAD models, representative locator tool, links to our available product literature, and much more!

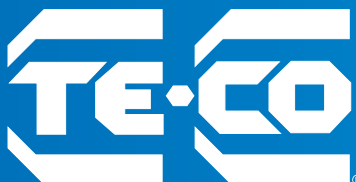

109 Quinter Farm Rd. Union, OH 45322
Phone: 800-543-4071 Fax: 937-832-1274
www.te-co.com

LIT0910CMM

**ISO 9001
CERTIFIED**