

SUPERO[®]

A+ SERVER
2122TG-H6IBQRF
2122TG-H6RF

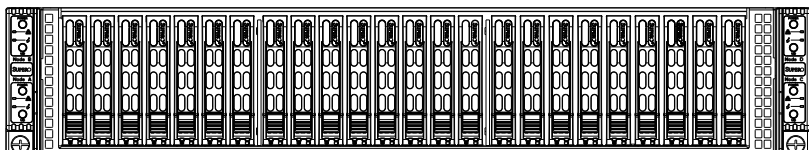

USER'S MANUAL
Revision 1.0c

The information in this User's Manual has been carefully reviewed and is believed to be accurate. The vendor assumes no responsibility for any inaccuracies that may be contained in this document, makes no commitment to update or to keep current the information in this manual, or to notify any person or organization of the updates. **Please Note: For the most up-to-date version of this manual, please see our web site at www.supermicro.com.**

Super Micro Computer, Inc. ("Supermicro") reserves the right to make changes to the product described in this manual at any time and without notice. This product, including software and documentation, is the property of Supermicro and/or its licensors, and is supplied only under a license. Any use or reproduction of this product is not allowed, except as expressly permitted by the terms of said license.

IN NO EVENT WILL SUPERMICRO BE LIABLE FOR DIRECT, INDIRECT, SPECIAL, INCIDENTAL, SPECULATIVE OR CONSEQUENTIAL DAMAGES ARISING FROM THE USE OR INABILITY TO USE THIS PRODUCT OR DOCUMENTATION, EVEN IF ADVISED OF THE POSSIBILITY OF SUCH DAMAGES. IN PARTICULAR, SUPERMICRO SHALL NOT HAVE LIABILITY FOR ANY HARDWARE, SOFTWARE, OR DATA STORED OR USED WITH THE PRODUCT, INCLUDING THE COSTS OF REPAIRING, REPLACING, INTEGRATING, INSTALLING OR RECOVERING SUCH HARDWARE, SOFTWARE, OR DATA.

Any disputes arising between manufacturer and customer shall be governed by the laws of Santa Clara County in the State of California, USA. The State of California, County of Santa Clara shall be the exclusive venue for the resolution of any such disputes. Super Micro's total liability for all claims will not exceed the price paid for the hardware product.

FCC Statement: This equipment has been tested and found to comply with the limits for a Class A digital device pursuant to Part 15 of the FCC Rules. These limits are designed to provide reasonable protection against harmful interference when the equipment is operated in a commercial environment. This equipment generates, uses, and can radiate radio frequency energy and, if not installed and used in accordance with the manufacturer's instruction manual, may cause harmful interference with radio communications. Operation of this equipment in a residential area is likely to cause harmful interference, in which case you will be required to correct the interference at your own expense.

California Best Management Practices Regulations for Perchlorate Materials: This Perchlorate warning applies only to products containing CR (Manganese Dioxide) Lithium coin cells. "Perchlorate Material-special handling may apply. See www.dtsc.ca.gov/hazardouswaste/perchlorate"

WARNING: Handling of lead solder materials used in this product may expose you to lead, a chemical known to the State of California to cause birth defects and other reproductive harm.

Manual Revision 1.0c
Release Date: March 11, 2014

Unless you request and receive written permission from Super Micro Computer, Inc., you may not copy any part of this document.

Information in this document is subject to change without notice. Other products and companies referred to herein are trademarks or registered trademarks of their respective companies or mark holders.

Copyright © 2014 by Super Micro Computer, Inc.
All rights reserved.

Printed in the United States of America

Preface

About This Manual

This manual is written for professional system integrators and PC technicians. It provides information for the installation and use of the A+ Server 2122TG-H6IBQRF/H6RF. Installation and maintenance should be performed by experienced technicians only.

The A+ Server 2122TG-H6IBQRF/H6RF is a high-end server based on the SC217HQ-R1620BP 2U rackmount chassis and the dual processor H8DGT-HLIBQF/HLF serverboards. The 2122TG-H6IBQRF server uses the H8DGT-HLIBQF serverboard, whereas the 2122TG-H6RF server uses the H8DGT-HLF serverboard. The only difference between the two serverboards is that the H8DGT-HLIBQF contains an InfiniBand™ connector and the H8DGT-HLF does not.

Manual Organization

Chapter 1: Introduction

The first chapter provides a checklist of the main components included with the server system and describes the main features of the H8DGT-HLIBQF/HLF serverboard and the SC217HQ-R1620BP chassis.

Chapter 2: Server Installation

This chapter describes the steps necessary to install the A+ Server 2122TG-H6IBQRF/H6RF into a rack and check out the server configuration prior to powering up the system. If your server was ordered without processor and memory components, this chapter will refer you to the appropriate sections of the manual for their installation.

Chapter 3: System Interface

Refer here for details on the system interface, which includes the functions and information provided by the control panel on the chassis as well as other LEDs located throughout the system.

Chapter 4: Warning Statements for AC Systems

You should thoroughly familiarize yourself with this chapter for a general overview of safety precautions that should be followed when installing and servicing the A+ Server 2122TG-H6IBQRF/H6RF.

Chapter 5: Advanced Serverboard Setup

Chapter 5 provides detailed information on the H8DGT-HLIBQF/HLF serverboard, including the locations and functions of connections, headers and jumpers. Refer to this chapter when adding or removing processors or main memory and when reconfiguring the serverboard.

Chapter 6: Advanced Chassis Setup

Refer to Chapter 6 for detailed information on the SC217HQ-R1620BP server chassis. You should follow the procedures given in this chapter when installing, removing or reconfiguring SAS/SATA or peripheral drives and when replacing system power supply units and cooling fans.

Chapter 7: BIOS

The BIOS chapter includes an introduction to BIOS and provides detailed information on running the CMOS Setup Utility.

Appendix A: BIOS Error Beep Codes

Appendix B: System Specifications

Table of Contents

Chapter 1 Introduction

1-1	Overview	1-1
1-2	Serverboard Features	1-2
	Processors	1-2
	Memory	1-2
	SAS	1-2
	PCI Expansion Slots	1-2
	Onboard Controllers/Ports	1-2
	Graphics Controller	1-3
	InfiniBand	1-3
	Other Features	1-3
1-3	Server Chassis Features	1-3
	System Power	1-3
	SAS Subsystem	1-3
	Front Control Panel	1-4
	Rear I/O	1-4
	Cooling System	1-4
	Air Shrouds	1-4
	Mounting Rails	1-4
1-4	Contacting Supermicro	1-6
1-5	2U Twin ² : System Notes	1-7
	Nodes	1-7
	System Power	1-7
	SAS/SATA Backplane/Drives	1-7

Chapter 2 Server Installation

2-1	Overview	2-1
2-2	Unpacking the System	2-1
2-3	Preparing for Setup	2-1
	Choosing a Setup Location	2-1
	Rack Precautions	2-2
	Server Precautions	2-2
	Rack Mounting Considerations	2-3
	Ambient Operating Temperature	2-3
	Reduced Airflow	2-3
	Mechanical Loading	2-3
	Circuit Overloading	2-3
	Reliable Ground	2-3

2-4	Installing the System into a Rack	2-4
	Identifying the Sections of the Rack Rails	2-4
	Locking Tabs	2-5
	Releasing the Inner Rail	2-5
	Installing The Inner Rails on the Chassis	2-6
	Installing the Outer Rails on the Rack	2-7
	Standard Chassis Installation	2-8
2-5	Checking the Serverboard Setup	2-9
2-6	Checking the Drive Bay Setup	2-10
2-7	Checking the Airflow	2-11
2-8	Installation Complete	2-11

Chapter 3 System Interface

3-1	Overview	3-1
3-2	Control Panel Button	3-2
3-3	Control Panel LEDs	3-2
3-4	Drive Carrier LEDs	3-3
	SAS/SATA Drives	3-3
	SCSI Drives	3-3

Chapter 4 System Safety

4-1	Electrical Safety Precautions	4-1
4-2	General Safety Precautions	4-2
4-3	ESD Precautions	4-3
4-4	Operating Precautions	4-4

Chapter 5 Advanced Serverboard Setup

5-1	Handling the Serverboard	5-1
	Precautions	5-1
	Unpacking	5-1
5-2	Connecting Cables	5-2
	Connecting Data Cables	5-2
5-3	I/O Port Connections	5-2
5-4	Processor and Heatsink Installation	5-3
	Installing a CPU Heatsink	5-5
	Removing the Heatsink	5-6
5-5	Installing Memory	5-7
	DIMM Module Population Configuration	5-8
5-6	PCI Expansion Cards	5-9
5-7	Serverboard Details	5-10
	H8DGT-HLIBQF/HLF Quick Reference	5-11

5-8	Connector Definitions	5-12
5-9	Jumper Settings	5-15
	Explanation of Jumpers	5-15
5-10	Onboard Indicators.....	5-17
5-11	Enabling SATA RAID.....	5-19
	Serial ATA (SATA).....	5-19
	Installing the OS/SATA Driver	5-19
	Building a Driver Diskette.....	5-19
	Enabling SATA RAID in the BIOS.....	5-20
	Using the Adaptec RAID Utility.....	5-21
	Installing the RAID Driver During OS Installation.....	5-21
5-12	Installing Drivers.....	5-22
	Supero Doctor III.....	5-23
5-13	Serverboard Battery	5-24
Chapter 6 Advanced Chassis Setup		
6-1	Static-Sensitive Devices.....	6-1
	Precautions	6-1
	Unpacking	6-1
6-2	Control Panel	6-2
6-3	Chassis Cover.....	6-3
6-4	Air Shrouds	6-4
6-6	System Fans	6-5
	Optional Fan Configurations	6-5
6-7	Removing and Installing the Backplane.....	6-8
	Removing the Backplane	6-8
	Installing the Backplane.....	6-10
6-8	Installing the Motherboard	6-11
	I/O Shield	6-11
	Permanent and Optional Standoffs.....	6-11
6-9	Adapter Card Replacement.....	6-13
	Add-on Card/Expansion Slot Setup	6-14
6-10	Drive Bay Installation/Removal.....	6-16
	Accessing the Drive Bays	6-16
6-11	Power Supply.....	6-20
	Power Supply Replacement.....	6-20
	Power Supply Replacement.....	6-20
	Installation Complete.....	6-21

Chapter 7 BIOS

7-1	Introduction.....	7-1
	Starting BIOS Setup Utility.....	7-1
	How To Change the Configuration Data.....	7-1
	Starting the Setup Utility.....	7-2
7-2	Main Setup.....	7-2
7-3	Advanced Setup Configurations.....	7-3
7-3	Security Menu.....	7-15
7-4	Boot Menu.....	7-15
7-5	Exit Menu.....	7-16

Appendix A BIOS Error Beep Codes

Appendix B System Specifications

Chapter 1

Introduction

1-1 Overview

The A+ SERVER 2122TG-H6IBQRF/H6RF is a high-end server comprised of the SC217HQ-R1620BP 2U server chassis and four distinct computing nodes each with the H8DGT-HLIBQF/HLF dual processor serverboard. Please refer to our web site for information on operating systems that have been certified for use with the system (www.supermicro.com).

In addition to the serverboard and chassis, various hardware components have been included with the 2122TG-H6IBQRF/H6RF, as listed below:

- Four (4) 80x80x38mm 4-pin PWM chassis fans (FAN-0129L4)
- Four (4) Air shrouds for H8DGT-HL serverboards (MCP-310-82713-0B)
- Eight (8) 1U Passive CPU heatsinks (SNK-P0037P)
- SAS/SATA
 - One (1) SAS hard disk drive (HDD) 2U twin backplane (BPN-SAS-217HQ)
 - Four (4) SAS2 adapter cards (BPN-ADP-SAS2-H6IR-0-P)
 - Twenty-four (24) 2.5" hot swap Hard Disk Drive trays (MCP-220-00047-0B)
- Four (4) Riser Cards (RSC-R1U-E16R-0-P)
- One (1) Rack mount rail kit (MCP-290-00053-0N)

Note: For your system to work properly, please follow the links below to download all necessary drivers/utilities and the user's manual for your server.

- Product manuals: <http://www.supermicro.com/support/manuals/>
- Product drivers and utilities: <ftp://ftp.supermicro.com>
- Product safety information:
http://supermicro.com/about/policies/safety_information.cfm

With questions, contact support@supermicro.com.

1-2 Serverboard Features

At the heart of the A+ Server 2122TG-H6IBQRF/H6RF lies the H8DGT-HLIBQF/HLF, a dual processor serverboard based on the AMD SR5690/SP5100 chipset and designed to provide maximum performance. Up to four of these serverboards can be mounted in the SC217 chassis.

The sections below cover the main features of the H8DGT-HLIBQF/HLF serverboard (see Figure 1-1 for a block diagram of the chipset).

Processors

The H8DGT-HLIBQF/HLF supports single or dual AMD Opteron 6000 series processors (AMD Socket G34 type). Please refer to the serverboard description pages on our web site for a complete listing of supported processors (www.supermicro.com).

Memory

Each H8DGT-HLIBQF/HLF serverboard has eight (8) single/dual/tri/quad channel DIMM slots that can support up to 64 GB of ECC/Non-ECC UDIMM or up to 256 GB of ECC RDIMM DDR3-1600/1333/1066 MHz speed SDRAM in 1 GB, 2 GB, 4 GB, 8 GB or 16 GB sizes of 1.5V or 1.35V voltages.

SAS

A LSI® SAS2108 SAS2 controller is integrated into the BPN-ADP-SAS2-H6IR-O-P backplane to provide an six port 6 Gb/s SAS2 (Serial Attached SCSI) subsystem, which is RAID 0, 1, 5, 6 and 10 supported. The SAS drives are hot-swappable units.

Note: The operating system you use must have RAID support to enable the hotswap capability and RAID function of the SAS drives

PCI Expansion Slots

Each H8DGT-HLIBQF/HLF serverboard has:

- One (1) PCI-Express x16 Gen. 2 slot
- One (1) PCI-Express x8 in x4 Gen. 2 slot (for SAS adapter cards)

Onboard Controllers/Ports

Onboard I/O back panel ports include one COM port, a VGA port, two Gb LAN ports, a dedicated IPMI LAN port, two USB ports and one single QSFP Mellanox Connect-X2 InfiniBand™ connector (2122TG-H6IBQRF only). Two USB headers and one USB Type-A port are also included on the motherboard.

Graphics Controller

The H8DGT-HLIBQF/HLF features an integrated Matrox® G200 graphics controller with 16 MB DDR2 memory.

InfiniBand

The 2122TG-H6IBQRF server includes a QDR (quad data rate) speed InfiniBand QSFP connector. InfiniBand is a scalable serial communications link intended for connecting processors with high-speed peripherals.

Other Features

Other onboard features that promote system health include voltage monitors, auto-switching voltage regulators, chassis and CPU overheat sensors and virus protection.

1-3 Server Chassis Features

The following is a general outline of the main features of the SC217 server chassis.

System Power

Each SC217 chassis model includes a high-efficiency 94-plus Platinum certified power supply, rated at 1620 Watts plus one redundant backup power supply. In the unlikely event your power supply fails, replacement is simple and can be accomplished without tools.

Note: Depending on the input power and certain workloads, configuration power supply redundancy may not always be available.

SAS Subsystem

The SC217 supports up to twenty-four (24) 2.5" hot-swap SAS/SATA drives in trays (6 for each node). These drives are hot-swappable units and are connected to a backplane that provides power and control.

Note: The operating system you use must have RAID support to enable the hot-swap capability of the drives.

Front Control Panel

SC217 models include four front panels on the handles of the chassis which control each of the systems. Each control panel on the A+ Server 2122TG-H6IBQRF/H6RF provides you with system monitoring and control for one server node. LEDs indicate system power, UID, HDD activity, network activity, system status and power supply failure. A main power button and a UID button are also included.

I/O Backplane

The SAS217HQ I/O backplane provides a total of 24 2.5" SATA/SAS HDDs, power button, UID button and LEDs for each node.

Rear I/O

Each computing node provides a low-profile add-on card slot, a COM port, a VGA port, two USB 2.0 ports, one IPMI Ethernet port, two gigabit Ethernet ports, and one Infiniband port per node (2122TG-H6IBQRF only).

Cooling System

The chassis accepts four system fans powered from the backplane. When Node A and/or Node B are powered on, both fans on the left of the chassis will run. When Node C and/or Node D are powered on, both fans on the right of the chassis will run.

Air Shrouds

The chassis includes four mylar air shrouds that direct the airflow where cooling is needed on each serverboard. Always use the air shroud included with your chassis on each serverboard.

Mounting Rails

The includes a set of quick-release rails, and can be placed in a rack for secure storage and use. To setup your rack, follow the instructions included in this manual.

**Figure 1-1. AMD SR5690/SP5100 Chipset:
System Block Diagram**

Note: This is a general block diagram. Please see Chapter 5 for details.

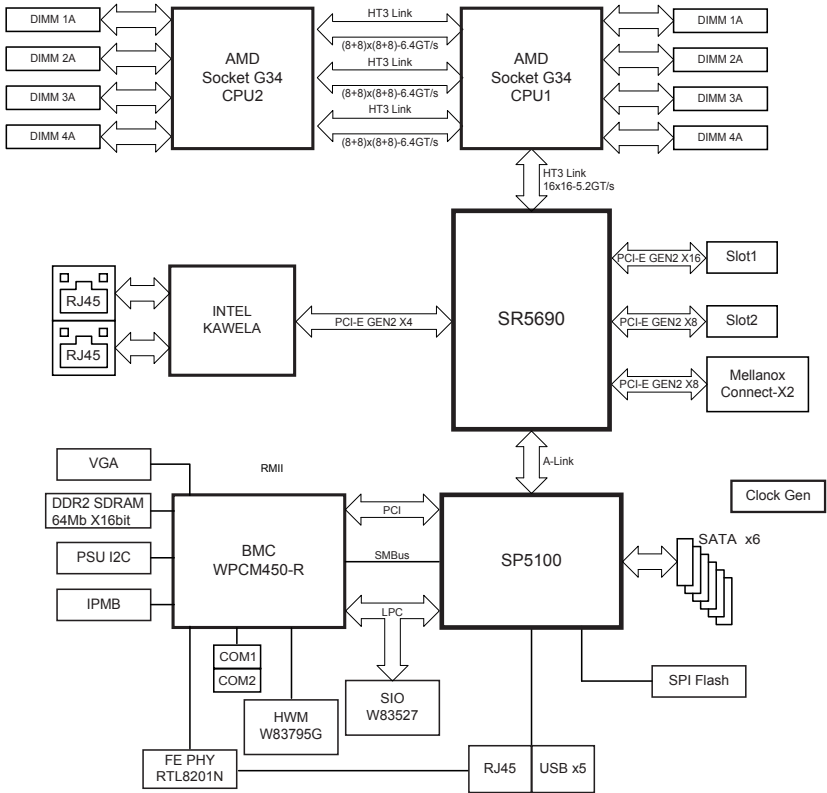

1-4 Contacting Supermicro

Headquarters

Address: Super Micro Computer, Inc.
980 Rock Ave.
San Jose, CA 95131 U.S.A.

Tel: +1 (408) 503-8000

Fax: +1 (408) 503-8008

Email: marketing@supermicro.com (General Information)
support@supermicro.com (Technical Support)

Web Site: www.supermicro.com

Europe

Address: Super Micro Computer B.V.
Het Sterrenbeeld 28, 5215 ML
's-Hertogenbosch, The Netherlands

Tel: +31 (0) 73-6400390

Fax: +31 (0) 73-6416525

Email: sales@supermicro.nl (General Information)
support@supermicro.nl (Technical Support)
rma@supermicro.nl (Customer Support)

Web Site: www.supermicro.com

Asia-Pacific

Address: Super Micro Computer, Inc.
3F, No. 150, Jian 1st Rd.
Zhonghe Dist., New Taipei City 235
Taiwan (R.O.C)

Tel: +886-(2) 8226-3990

Fax: +886-(2) 8226-3992

Email: support@supermicro.com.tw

Tel: +886-(2)-8226-3990

Web Site: www.supermicro.com.tw

1-5 2U Twin²: System Notes

As a 2U Twin² configuration, the 2122TG-H6IBQRF/H6RF is a unique server system. With four system boards incorporated into a single chassis acting as four separate nodes, there are several points you should keep in mind.

Nodes

Each of the four serverboards act as a separate node in the system. As independant nodes, each may be powered off and on without affecting the others. In addition, each node is a hot-swappable unit that may be removed from the rear of the chassis. The nodes are connected to the server backplane by means of an adapter card.

Note: A guide pin is located between the upper and lower nodes on the inner chassis wall. This guide pin also acts as a “stop” when a node is fully installed. If too much force is used when inserting a node this pin may break off. Take care to slowly slide a node in until you hear the “click” of the locking tab seating itself.

System Power

A single 1620 Watts power supply can be used to provide the power for all four serverboards. Each serverboard however, can be shut down independently of the other with the power button on its own control panel. As a default, the A+ Server 2122TG-H6IBQRF/H6RF comes with a second power supply module for power redundancy.

Note: Redundant power availability will vary by configuration.

SAS/SATA Backplane/Drives

As a system, the 2122TG-H6IBQRF/H6RF supports the use of twenty-four (24) SAS/SATA drives. A single SAS/SATA backplane works to apply system-based control for power and fan speed functions, yet at the same time logically connects a set of six SAS/SATA drives to each serverboard. Consequently, RAID setup is limited to a six-drive scheme (RAID cannot be spread across all twenty-four drives). See the *Drive Bay Installation/Removal* section in Chapter 6 for the logical hard drive and node configuration.

Notes

Chapter 2

Server Installation

2-1 Overview

This chapter provides a quick setup checklist to get your A+ Server 2122TG-H6IBQRF/H6RF up and running. Following these steps in the order given should enable you to have the system operational within a minimum amount of time. This quick setup assumes that your system has come to you with the processors and memory preinstalled. If your system is not already fully integrated with a serverboard, processors, system memory etc., please turn to the chapter or section noted in each step for details on installing specific components.

2-2 Unpacking the System

You should inspect the box the A+ Server 2122TG-H6IBQRF/H6RF was shipped in and note if it was damaged in any way. If the server itself shows damage you should file a damage claim with the carrier who delivered it.

Decide on a suitable location for the rack unit that will hold the A+ Server 2122TG-H6IBQRF/H6RF. It should be situated in a clean, dust-free area that is well ventilated. Avoid areas where heat, electrical noise and electromagnetic fields are generated. You will also need it placed near a grounded power outlet. Read the Rack and Server Precautions in the next section.

2-3 Preparing for Setup

The box the A+ Server 2122TG-H6IBQRF/H6RF was shipped in should include two sets of rail assemblies, two rail mounting brackets and the mounting screws you will need to install the system into the rack. Follow the steps in the order given to complete the installation process in a minimum amount of time. Please read this section in its entirety before you begin the installation procedure outlined in the sections that follow.

Choosing a Setup Location

- Leave enough clearance in front of the rack to enable you to open the front door completely (~25 inches) and approximately 30 inches of clearance in the back of the rack to allow for sufficient airflow and ease in servicing.

- This product is for installation only in a Restricted Access Location (dedicated equipment rooms, service closets and the like).
- This product is not suitable for use with visual display work place devices according to §2 of the the German Ordinance for Work with Visual Display Units.

Rack Precautions



Warning: To prevent bodily injury when mounting or servicing this unit in a rack, you must take special precautions to ensure that the system remains stable. The following guidelines are provided to ensure your safety:

- This unit should be mounted at the bottom of the rack if it is the only unit in the rack.
- When mounting this unit in a partially filled rack, load the rack from the bottom to the top with the heaviest component at the bottom of the rack.
- If the rack is provided with stabilizing devices, install the stabilizers before mounting or servicing the unit in the rack.
- Ensure that the leveling jacks on the bottom of the rack are fully extended to the floor with the full weight of the rack resting on them.
- In single rack installation, stabilizers should be attached to the rack. In multiple rack installations, the racks should be coupled together.
- Always make sure the rack is stable before extending a component from the rack.
- You should extend only one component at a time. Extending two or more simultaneously may cause the rack to become unstable.

Server Precautions

- Review the electrical and general safety precautions in Chapter 4.
- Determine the placement of each component in the rack *before* you install the rails.
- Install the heaviest server components on the bottom of the rack first, and then work up.
- Use a regulating uninterruptible power supply (UPS) to protect the server from power surges, voltage spikes and to keep your system operating in case of a power failure.
- Allow any hot plug drives and power supply modules to cool before touching them.
- Always keep the rack's front door and all panels and components on the servers closed when not servicing to maintain proper cooling.

Rack Mounting Considerations

Ambient Operating Temperature

If installed in a closed or multi-unit rack assembly, the ambient operating temperature of the rack environment may be greater than the ambient temperature of the room. Therefore, consideration should be given to installing the equipment in an environment compatible with the manufacturer's maximum rated ambient temperature (T_{mra}).

Reduced Airflow

Equipment should be mounted into a rack so that the amount of airflow required for safe operation is not compromised.

Mechanical Loading

Equipment should be mounted into a rack so that a hazardous condition does not arise due to uneven mechanical loading.

Circuit Overloading

Consideration should be given to the connection of the equipment to the power supply circuitry and the effect that any possible overloading of circuits might have on overcurrent protection and power supply wiring. Appropriate consideration of equipment nameplate ratings should be used when addressing this concern.

Reliable Ground

A reliable ground must be maintained at all times. To ensure this, the rack itself should be grounded. Particular attention should be given to power supply connections other than the direct connections to the branch circuit (i.e. the use of power strips, etc.).

2-5 Installing the System into a Rack

This section provides information on installing the chassis into a rack unit with the rails provided. There are a variety of rack units on the market, which may mean that the assembly procedure will differ slightly from the instructions provided. You should also refer to the installation instructions that came with the rack unit you are using. **Note:** This rail will fit a rack between 26.5" and 36.4" deep.

Identifying the Sections of the Rack Rails

The chassis package includes two rail assemblies in the rack mounting kit. Each assembly consists of three sections: An inner chassis rail which secures directly to the chassis, an outer rail that secures to the rack, and a middle rail which extends from the outer rail (see Figure 2-1). These assemblies are specifically designed for the left and right side of the chassis.

Figure 2-1. Identifying the Outer Rail, Middle Rail and Inner Rails (Left Rail Assembly Shown)

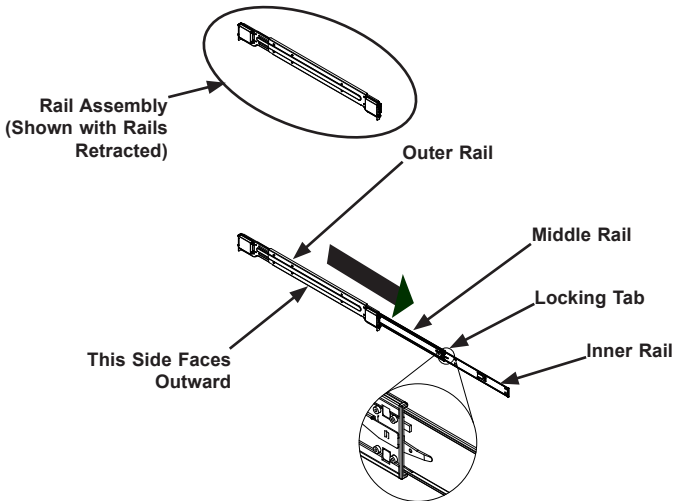

Locking Tabs

Each inner rail has a locking tab. This tab locks the chassis into place when installed and pushed fully into the rack. These tabs also lock the chassis in place when fully extended from the rack. This prevents the server from coming completely out of the rack when the chassis is pulled out for servicing.

Releasing the Inner Rail

Use the procedure below to release the inner rails from the outer rails.

Releasing Inner Rail from the Outer Rails (Figure 2-2)

1. Identify the left and right outer rail assemblies as described on page 2-4.
2. Pull the inner rail out of the outer rail until it is fully extended as illustrated below.
3. Press the locking tab down to release the inner rail.
4. Pull the inner rail all the way out.
5. Repeat steps 1-3 for the second outer rail.

Figure 2-2. Extending and Releasing the Inner Rail

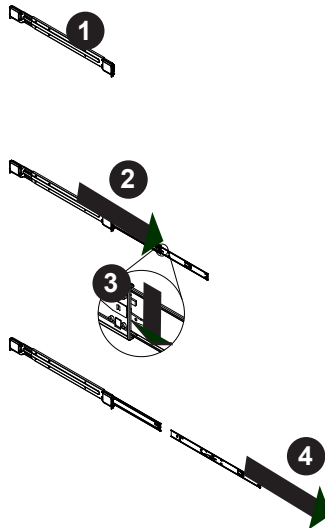

Installing The Inner Rails on the Chassis

To install the inner rails, use the procedure below.

Installing the Inner Rails (Figure 2-3 and Figure 2-4)

1. Confirm that the left and right inner rails have been correctly identified.
2. Place the inner rail firmly against the side of the chassis, aligning the hooks on the side of the chassis with the holes in the inner rail.
3. Slide the inner rail forward toward the front of the chassis until the rail clicks into the locked position, which secures the inner rail to the chassis.
4. Secure the inner rail to the chassis with the screws provided.
5. Repeat steps 1 through 4 above for the other inner rail

Figure 2-3. Installing the Inner Rails

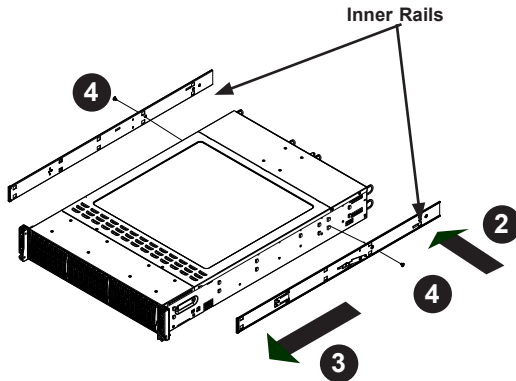
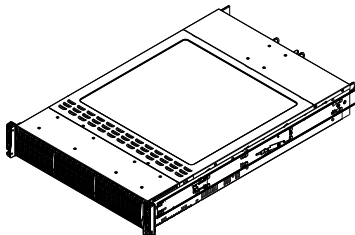

Figure 2-4. Inner Rails Installed on the Chassis

(The chassis above are an example only. Actual chassis may differ slightly)



Installing the Outer Rails on the Rack

Use the procedure below to install the outer rails onto the rack.

Installing the Outer Rails (Figure 2-5)

1. Press upward on the locking tab at the rear end of the middle rail.
2. Push the middle rail back into the outer rail.
3. Hang the hooks of the front of the outer rail onto the slots on the front of the rack. If necessary, use screws to secure the outer rails to the rack, as illustrated above.
4. Pull out the rear of the outer rail, adjusting the length until it fits within the posts of the rack.
5. Hang the hooks of the rear portion of the outer rail onto the slots on the rear of the rack. If necessary, use screws to secure the rear of the outer rail to the rear of the rack.
6. Repeat steps 1-5 for the remaining outer rail.

Figure 2-5. Extending and Releasing the Outer Rails

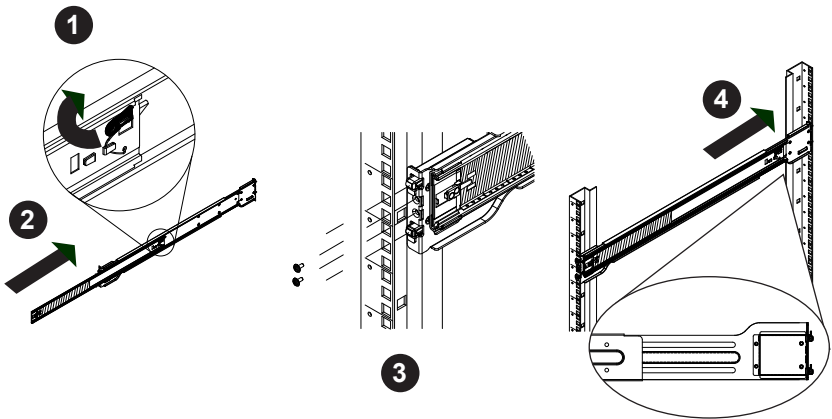

Standard Chassis Installation



Stability hazard. The rack stabilizing mechanism must be in place, or the rack must be bolted to the floor before you slide the unit out for servicing. Failure to stabilize the rack can cause the rack to tip over.

Installing the Chassis into a Rack (Figure 2-6)

1. Confirm that the inner rails are properly installed on the chassis.
2. Confirm that the outer rails are correctly installed on the rack.
3. Pull the middle rail out from the front of the outer rail and make sure that the ball-bearing shuttle is at the front locking position of the middle rail.
4. Align the chassis inner rails with the front of the middle rails.
5. Slide the inner rails on the chassis into the middle rails, keeping the pressure even on both sides, until the locking tab of the inner rail clicks into the front of the middle rail, locking the chassis into the fully extended position.
6. Depress the locking tabs of both sides at the same time and push the chassis all the way into the rear of the rack.
7. If necessary for security purposes, use screws to secure the chassis handles to the front of the rack.

Figure 2-6. Installing into a Rack
Ball-Bearing Shuttle

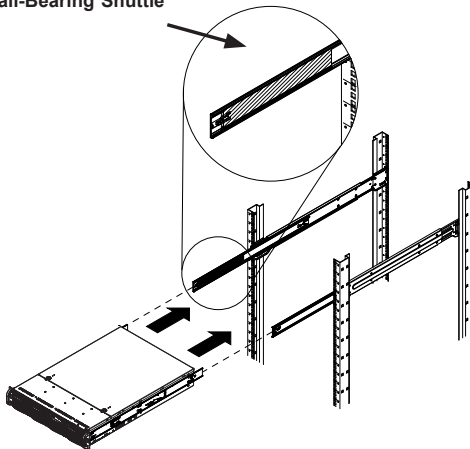

Warning: Do not pick up the server with the front handles. They are designed to pull the system from a rack only.

2-6 Checking the Serverboard Setup

After you install the A+ Server 2122TG-H6IBQRF/H6RF in the rack, you will need to open the unit to make sure the serverboard is properly installed and all the connections have been made.

Before operating the SC217 chassis for the first time, it is important to remove the protective film covering the top of the chassis, in order to allow for proper ventilation and cooling.

Removing the Chassis Cover and Protective Film (Figure 2-7)

1. Unplug the AC power cord from any external power source.
2. Remove the two screws which secure the top cover onto the chassis as shown above.
3. Lift the top cover up and off the chassis.
4. Peel off the protective film covering the top cover and the top of the chassis
5. Check that all ventilation openings on the top cover and the top of the chassis are clear and unobstructed.

Replace the chassis cover and reconnect the AC power cord.

Figure 2-7. Accessing the Inside of the System

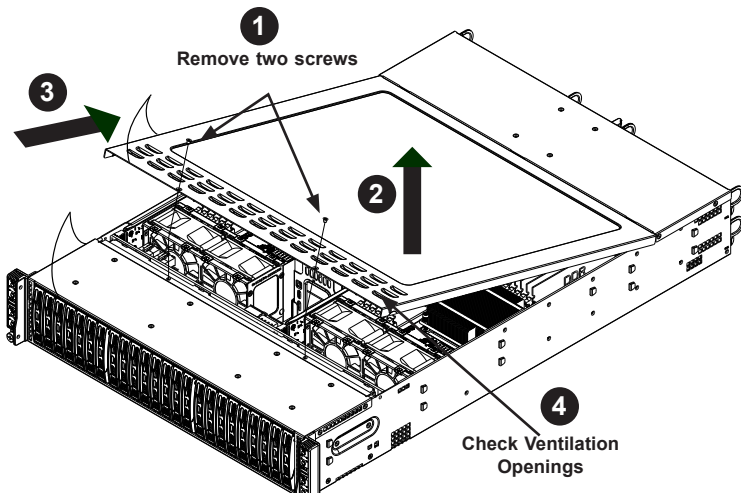

Caution: Except for short periods of time, do not operate the server without the cover in place. The chassis cover must be in place to allow proper airflow and prevent overheating.

Checking the Components and Setup

- You may have one or two processors already installed into the serverboard. Each processor needs its own heat sink. See Chapter 5 for instructions on processor and heat sink installation.
- Your A+ Server 2122TG-H6IBQRF/H6RF server system may have come with system memory already installed. Make sure all DIMMs are fully seated in their slots. For details on adding system memory, refer to Chapter 5.
- If desired, you can install add-on cards to the system. See Chapter 5 for details on installing PCI add-on cards.
- Make sure all power and data cables are properly connected and not blocking the chassis airflow. Also make sure that no cables are positioned in front of the fans. See Chapter 5 for details on cable connections.

2-7 Checking the Drive Bay Setup

Checking the Drives

Next, you should check to make sure the peripheral drives and the SATA drives have been properly installed and all connections have been made.

- All drives are accessible from the front of the server. A hard drive can be installed and removed from the front of the chassis without removing the top chassis cover.
- Depending upon your system's configuration, your system may have one or more drives already installed. If you need to install hard drives, please refer to Chapter 6.

Checking the Airflow

- Airflow is provided by four hot-swappable 8-cm cooling fans. The layout was carefully designed to direct sufficient cooling airflow to the components that generate the most heat.
- Note that all power and data cables have been routed in such a way that they do not block the airflow generated by the fans.

2-8 Providing Power

1. Plug the power cords from the power supply units into a high-quality power strip that offers protection from electrical noise and power surges. It is recommended that you use an uninterruptible power supply (UPS).
2. Depress the power on buttons on the front of the chassis.

Chapter 3

System Interface

3-1 Overview

There are several LEDs on the control panel and on the drive carriers to keep you constantly informed of the overall status of the system. SC217 chassis models include four front panels on the handles of the chassis which control each of the systems.

This chapter explains the meanings of all LED indicators and the appropriate response you may need to take.

Figure 3-1. Control Panel

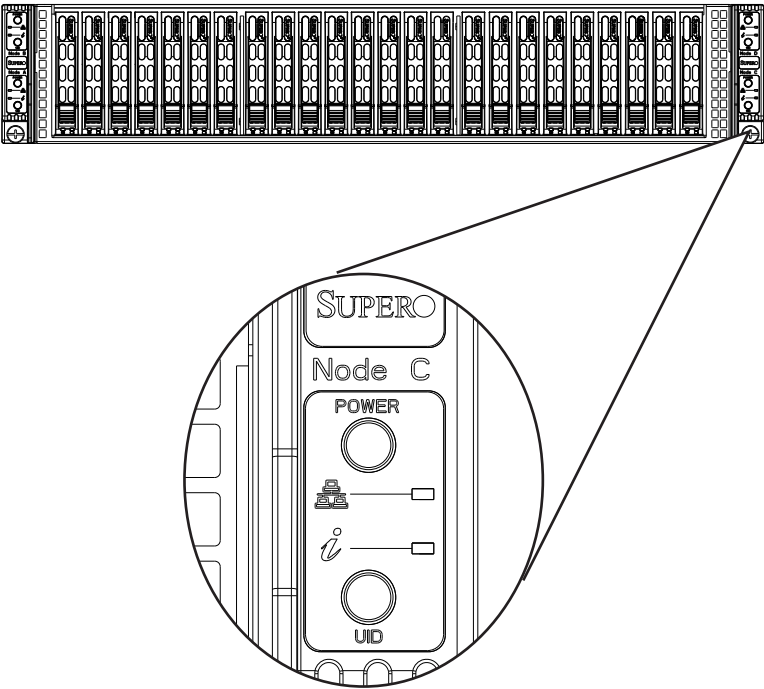

3-2 Control Panel Button

POWER



Power: The main power button on each of the four control panels is used to apply or remove power from the power supply to each of the four systems in the chassis. Turning power to the system off with this button removes the main power, but keeps standby power supplied to the system. Therefore, you must unplug the AC power cord from any external power source before servicing. The power button has a built-in LED which will turn green when the power is on.



UID: When used with a UID compatible motherboard, the UID button is used to turn on or off the blue light function of the LED. This is built into the front side of the UID button and at the rear end of each motherboard node, for those motherboards which support it. Once the blue light is activated, the unit can be easily located in very large racks and server banks.

3-3 Control Panel LEDs

The four control panels are located on the front handle of the SC217 chassis. Each control panel has two additional LEDs that provide status information about the system.



Information LED: Alerts operator of several states, as noted in the table below.

Information LED	
Status	Description
Continuously on and red	An overheat condition has occurred. (This may be caused by cable congestion.)
Blinking red (1Hz)	Fan failure, check for an inoperative fan.
Blinking red (0.25Hz)	Power failure, check for a non-operational power supply.
Solid blue	Local UID has been activated. Use this function to locate the server in a rack mount environment.
Blinking blue	Remote UID is on. Use this function to identify the server from a remote location.



NIC: Indicates network activity on either LAN1 or LAN2 when flashing..

3-4 Drive Carrier LEDs

The SC217 chassis uses SAS/SATA drives.

SAS/SATA Drives

Each drive carrier has two LEDs.

- **Green:** Each drive carrier has a green LED. When illuminated, this green LED (on the front of the SAS/SATA drive carrier) indicates drive activity. A connection to the SATA backplane enables this LED to blink on and off when that particular drive is being accessed.
- **Red:** The red LED to indicate an SAS/SATA drive failure. If one of the drives fails, you should be notified by your system management software.

SCSI Drives

This chassis does not support SCSI drives at this time.

Notes

Chapter 4

Standardized Warning Statements for AC Systems

4-1 About Standardized Warning Statements

The following statements are industry standard warnings, provided to warn the user of situations which have the potential for bodily injury. Should you have questions or experience difficulty, contact Supermicro's Technical Support department for assistance. Only certified technicians should attempt to install or configure components.

Read this appendix in its entirety before installing or configuring components in the Supermicro chassis.

These warnings may also be found on our web site at http://www.supermicro.com/about/policies/safety_information.cfm.

Warning Definition



Warning!

This warning symbol means danger. You are in a situation that could cause bodily injury. Before you work on any equipment, be aware of the hazards involved with electrical circuitry and be familiar with standard practices for preventing accidents.

警告の定義

この警告サインは危険を意味します。

人身事故につながる可能性がありますので、いずれの機器でも動作させる前に、電気回路に含まれる危険性に注意して、標準的な事故防止策に精通して下さい。

此警告符号代表危險。

您正处于可能受到严重伤害的工作环境中。在您使用设备开始工作之前，必须充分意识到触电的危险，并熟练掌握防止事故发生的标准工作程序。请根据每项警告结尾的声明号码找到此设备的安全性警告说明的翻译文本。

此警告符號代表危險。

您正處於可能身體可能會受損傷的工作環境中。在您使用任何設備之前，請注意觸電的危險，並且要熟悉預防事故發生的標準工作程序。請依照每一注意事項後的號碼找到相關的翻譯說明內容。

Warnung

WICHTIGE SICHERHEITSHINWEISE

Dieses Warnsymbol bedeutet Gefahr. Sie befinden sich in einer Situation, die zu Verletzungen führen kann. Machen Sie sich vor der Arbeit mit Geräten mit den Gefahren elektrischer Schaltungen und den üblichen Verfahren zur Vorbeugung vor Unfällen vertraut. Suchen Sie mit der am Ende jeder Warnung angegebenen Anweisungsnummer nach der jeweiligen Übersetzung in den übersetzten Sicherheitshinweisen, die zusammen mit diesem Gerät ausgeliefert wurden.

BEWAHREN SIE DIESE HINWEISE GUT AUF.

INSTRUCCIONES IMPORTANTES DE SEGURIDAD

Este símbolo de aviso indica peligro. Existe riesgo para su integridad física. Antes de manipular cualquier equipo, considere los riesgos de la corriente eléctrica y familiarícese con los procedimientos estándar de prevención de accidentes. Al final de cada advertencia encontrará el número que le ayudará a encontrar el texto traducido en el apartado de traducciones que acompaña a este dispositivo.

GUARDE ESTAS INSTRUCCIONES.

IMPORTANTES INFORMATIONS DE SÉCURITÉ

Ce symbole d'avertissement indique un danger. Vous vous trouvez dans une situation pouvant entraîner des blessures ou des dommages corporels. Avant de travailler sur un équipement, soyez conscient des dangers liés aux circuits électriques et familiarisez-vous avec les procédures couramment utilisées pour éviter les accidents. Pour prendre connaissance des traductions des avertissements figurant dans les consignes de sécurité traduites qui accompagnent cet appareil, référez-vous au numéro de l'instruction situé à la fin de chaque avertissement.

CONSERVEZ CES INFORMATIONS.

תקנת הצהרות אזהרה

הצהרות הבאות הן אזהרות על פי תקני התעשייה, על מנת להזהיר את המשתמש מפני חבלה פיזית אפשרית. במידה ויש שאלות או היתקלות בבעיה כלשהי, יש ליצור קשר עם מחלקת תמיכה טכנית של סופרמיקרו. טכנאים מוסמכים בלבד רשאים להתקין או להגדיר את הרכיבים.

יש לקרוא את הנספח במלואו לפני התקנת או הגדרת הרכיבים במארוי סופרמיקרו.

تحذير! هذا الرمز يعني خطر انك في حالة يمكن أن تتسبب في اصابة جسدية .
قبل أن تعمل على أي معدات، كن على علم بالمخاطر الناجمة عن الدوائر
الكهربائية
وكن على دراية بالممارسات الوقائية لمنع وقوع أي حوادث
استخدم رقم البيان المنصوص في نهاية كل تحذير للعثور ترجمتها

안전을 위한 주의사항

경고!

이 경고 기호는 위험이 있음을 알려 줍니다. 작업자의 신체에 부상을 야기 할 수 있는 상태에 있게 됩니다. 모든 장비에 대한 작업을 수행하기 전에 전기회로와 관련된 위험요소들을 확인하시고 사전에 사고를 방지할 수 있도록 표준 작업절차를 준수해 주시기 바랍니다.

해당 번역문을 찾기 위해 각 경고의 마지막 부분에 제공된 경고문 번호를 참조하십시오

BELANGRIJKE VEILIGHEIDSIINSTRUCTIES

Dit waarschuwings symbool betekent gevaar. U verkeert in een situatie die lichamelijk letsel kan veroorzaken. Voordat u aan enige apparatuur gaat werken, dient u zich bewust te zijn van de bij een elektrische installatie betrokken risico's en dient u op de hoogte te zijn van de standaard procedures om ongelukken te voorkomen. Gebruik de nummers aan het eind van elke waarschuwing om deze te herleiden naar de desbetreffende locatie.

BEWAAR DEZE INSTRUCTIES

Installation Instructions



Warning!

Read the installation instructions before connecting the system to the power source.

設置手順書

システムを電源に接続する前に、設置手順書をお読み下さい。

警告

将此系统连接电源前，请先阅读安装说明。

警告

將系統與電源連接前，請先閱讀安裝說明。

Warnung

Vor dem Anschließen des Systems an die Stromquelle die Installationsanweisungen lesen.

¡Advertencia!

Lea las instrucciones de instalación antes de conectar el sistema a la red de alimentación.

Attention

Avant de brancher le système sur la source d'alimentation, consulter les directives d'installation.

יש לקרוא את הוראות התקנה לפני חיבור המערכת למקור מתח.

اقرأ إرشادات التركيب قبل توصيل النظام إلى مصدر للطاقة

시스템을 전원에 연결하기 전에 설치 안내를 읽어주십시오.

Waarschuwing

Raadpleeg de installatie-instructies voordat u het systeem op de voedingsbron aansluit.

Circuit Breaker



Warning!

This product relies on the building's installation for short-circuit (overcurrent) protection. Ensure that the protective device is rated not greater than: 250 V, 20 A.

サーキット・ブレーカー

この製品は、短絡(過電流)保護装置がある建物での設置を前提としています。

保護装置の定格が250 V、20 Aを超えないことを確認下さい。

警告

此产品的短路(过载电流)保护由建筑物的供电系统提供,确保短路保护设备的额定电流不大于250V,20A。

警告

此产品的短路(過載電流)保護由建築物的供電系統提供,確保短路保護設備的額定電流不大於250V,20A。

Warnung

Dieses Produkt ist darauf angewiesen, dass im Gebäude ein Kurzschluss- bzw. Überstromschutz installiert ist. Stellen Sie sicher, dass der Nennwert der Schutzvorrichtung nicht mehr als: 250 V, 20 A beträgt.

¡Advertencia!

Este equipo utiliza el sistema de protección contra cortocircuitos (o sobrecorrientes) del edificio. Asegúrese de que el dispositivo de protección no sea superior a: 250 V, 20 A.

Attention

Pour ce qui est de la protection contre les courts-circuits (surtension), ce produit dépend de l'installation électrique du local. Vérifiez que le courant nominal du dispositif de protection n'est pas supérieur à :250 V, 20 A.

מוצר זה מסתמך על הגנה המותקנת במבנים למניעת קצר חשמלי. יש לוודא כי המכשיר המגן מפני הקצר החשמלי הוא לא יותר מ-250 V, 20 A

هذا المنتج يعتمد على معدات الحماية من الدوائر القصيرة التي تم تثبيتها في المبنى

تأكد من أن تقييم الجهاز الوقائي ليس أكثر من: 20A, 250V

경고!

이 제품은 전원의 단락(과전류)방지에 대해서 전적으로 건물의 관련 설비에 의존합니다. 보호장치의 정격이 반드시 250V(볼트), 20A(암페어)를 초과하지 않도록 해야 합니다.

Waarschuwing

Dit product is afhankelijk van de kortsluitbeveiliging (overspanning) van uw elektrische installatie. Controleer of het beveiligde apparaat niet groter gedimensioneerd is dan 220V, 20A.

Power Disconnection Warning



Warning!

The system must be disconnected from all sources of power and the power cord removed from the power supply module(s) before accessing the chassis interior to install or remove system components.

電源切斷の警告

システムコンポーネントの取り付けまたは取り外しのために、シャーシ内部にアクセスするには、

システムの電源はすべてのソースから切斷され、電源コードは電源モジュールから取り外す必要があります。

警告

在你打开机箱并安装或移除内部器件前，必须将系统完全断电，并移除电源线。

警告

在您打開機殼安裝或移除內部元件前，必須將系統完全斷電，並移除電源線。

Warnung

Das System muss von allen Quellen der Energie und vom Netzanschlusskabel getrennt sein, das von den Spg.Versorgungsteilmodulen entfernt wird, bevor es auf den Chassisinnenraum zurückgreift, um Systemsbestandteile anzubringen oder zu entfernen.

¡Advertencia!

El sistema debe ser disconnected de todas las fuentes de energía y del cable eléctrico quitado de los módulos de fuente de alimentación antes de tener acceso el interior del chasis para instalar o para quitar componentes de sistema.

Attention

Le système doit être débranché de toutes les sources de puissance ainsi que de son cordon d'alimentation secteur avant d'accéder à l'intérieur du châssis pour installer ou enlever des composants de système.

אזהרה!

יש לנתק את המערכת מכל מקורות החשמל ויש להסיר את כבל החשמלי מהספק לפני גישה לחלק הפנימי של המארז לצורך התקנת או הסרת רכיבים.

يجب فصل النظام من جميع مصادر الطاقة وإزالة سلك الكهرباء من وحدة امداد الطاقة قبل الوصول إلى المناطق الداخلية للهيكल لتثبيت أو إزالة مكونات الجهاز

경고!

시스템에 부품들을 장착하거나 제거하기 위해서는 새시 내부에 접근하기 전에 반드시 전원 공급장치로부터 연결되어있는 모든 전원과 전기코드를 분리해주어야 합니다.

Waarschuwing

Voordat u toegang neemt tot het binnenwerk van de behuizing voor het installeren of verwijderen van systeem onderdelen, dient u alle spanningsbronnen en alle stroomkabels aangesloten op de voeding(en) van de behuizing te verwijderen

Equipment Installation



Warning!

Only trained and qualified personnel should be allowed to install, replace, or service this equipment.

機器の設置

トレーニングを受け認定された人だけがこの装置の設置、交換、またはサービスを許可されています。

警告

只有经过培训且具有资格的人员才能进行此设备的安装、更换和维修。

警告

只有經過受訓且具資格人員才可安裝、更換與維修此設備。

Warnung

Das Installieren, Ersetzen oder Bedienen dieser Ausrüstung sollte nur geschultem, qualifiziertem Personal gestattet werden.

¡Advertencia!

Solamente el personal calificado debe instalar, reemplazar o utilizar este equipo.

Attention

Il est vivement recommandé de confier l'installation, le remplacement et la maintenance de ces équipements à des personnels qualifiés et expérimentés.

אזהרה!

צוות מוסמך בלבד רשאי להתקין, להחליף את הציוד או לתת שירות עבור הציוד.

يجب أن يسمح فقط للموظفين المؤهلين والمدربين لتثبيت واستبدال أو خدمة هذا الجهاز

경고!

훈련을 받고 공인된 기술자만이 이 장비의 설치, 교체 또는 서비스를 수행할 수 있습니다.

Waarschuwing

Deze apparatuur mag alleen worden geïnstalleerd, vervangen of hersteld door geschoold en gekwalificeerd personeel.

Restricted Area



Warning!

This unit is intended for installation in restricted access areas. A restricted access area can be accessed only through the use of a special tool, lock and key, or other means of security. (This warning does not apply to workstations).

アクセス制限区域

このユニットは、アクセス制限区域に設置されることを想定しています。

アクセス制限区域は、特別なツール、鍵と錠前、その他のセキュリティの手段を用いてのみ出入りが可能です。

警告

此部件应安装在限制进出的场所，限制进出的场所指只能通过使用特殊工具、锁和钥匙或其它安全手段进出的场所。

警告

此裝置僅限安裝於進出管制區域，進出管制區域係指僅能以特殊工具、鎖頭及鑰匙或其他安全方式才能進入的區域。

Warnung

Diese Einheit ist zur Installation in Bereichen mit beschränktem Zutritt vorgesehen. Der Zutritt zu derartigen Bereichen ist nur mit einem Spezialwerkzeug, Schloss und Schlüssel oder einer sonstigen Sicherheitsvorkehrung möglich.

¡Advertencia!

Esta unidad ha sido diseñada para instalación en áreas de acceso restringido. Sólo puede obtenerse acceso a una de estas áreas mediante la utilización de una herramienta especial, cerradura con llave u otro medio de seguridad.

Attention

Cet appareil doit être installée dans des zones d'accès réservés. L'accès à une zone d'accès réservé n'est possible qu'en utilisant un outil spécial, un mécanisme de verrouillage et une clé, ou tout autre moyen de sécurité.

אזור עם גישה מוגבלת

אזהרה!

יש להתקין את היחידה באזורים שיש בהם הגבלת גישה. הגישה ניתנת בעזרת כלי אבטחה בלבד (מפתח, מנעול וכד').

تم تخصيص هذه الوحدة لت تركيبها في مناطق محظورة .
يمكن الوصول إلى منطقة محظورة فقط من خلال استخدام أداة خاصة،
قفل ومفتاح أو أي وسيلة أخرى للالأمين

경고!

이 장치는 접근이 제한된 구역에 설치하도록 되어 있습니다. 특수도구, 잠금 장치 및 키, 또는 기타 보안 수단을 통해서만 접근 제한 구역에 들어갈 수 있습니다.

Waarschuwing

Dit apparaat is bedoeld voor installatie in gebieden met een beperkte toegang. Toegang tot dergelijke gebieden kunnen alleen verkregen worden door gebruik te maken van speciaal gereedschap, slot en sleutel of andere veiligheidsmaatregelen.

Battery Handling



Warning!

There is the danger of explosion if the battery is replaced incorrectly. Replace the battery only with the same or equivalent type recommended by the manufacturer. Dispose of used batteries according to the manufacturer's instructions

電池の取り扱い

電池交換が正しく行われなかった場合、破裂の危険性があります。交換する電池はメーカーが推奨する型、または同等のものを使用下さい。使用済電池は製造元の指示に従って処分して下さい。

警告

電池更換不當會有爆炸危險。請只使用同類電池或製造商推薦的功能相當的電池更換原有電池。請按製造商的說明處理廢舊電池。

警告

電池更換不當會有爆炸危險。請使用製造商建議之相同或功能相當的電池更換原有電池。請按照製造商的說明指示處理廢棄舊電池。

Warnung

Bei Einsetzen einer falschen Batterie besteht Explosionsgefahr. Ersetzen Sie die Batterie nur durch den gleichen oder vom Hersteller empfohlenen Batterietyp. Entsorgen Sie die benutzten Batterien nach den Anweisungen des Herstellers.

Attention

Danger d'explosion si la pile n'est pas remplacée correctement. Ne la remplacer que par une pile de type semblable ou équivalent, recommandée par le fabricant. Jeter les piles usagées conformément aux instructions du fabricant.

¡Advertencia!

Existe peligro de explosión si la batería se reemplaza de manera incorrecta. Reemplazar la batería exclusivamente con el mismo tipo o el equivalente recomendado por el fabricante. Desechar las baterías gastadas según las instrucciones del fabricante.

אזהרה!

קיימת סכנת פיצוץ של הסוללה במידה והוחלפה בדרך לא תקינה. יש להחליף את הסוללה בסוג התואם מחברת יצרן מומלצת.

סילוק הסוללות המשומשות יש לבצע לפי הוראות היצרן.

هناك خطر من انفجار في حالة استبدال البطارية بطريقة غير صحيحة فعليك استبدال البطارية فقط بنفس النوع أو ما يعادلها كما أوصت به الشركة المصنعة تخلص من البطاريات المستعملة وفقا لتعليمات الشركة الصانعة

경고!

배터리가 올바르게 교체되지 않으면 폭발의 위험이 있습니다. 기존 배터리와 동일하거나 제조사에서 권장하는 동등한 종류의 배터리로만 교체해야 합니다. 제조사의 안내에 따라 사용된 배터리를 처리하여 주십시오.

Waarschuwing

Er is ontploffingsgevaar indien de batterij verkeerd vervangen wordt. Vervang de batterij slechts met hetzelfde of een equivalent type die door de fabrikant aanbevolen wordt. Gebruikte batterijen dienen overeenkomstig fabrieksvoorschriften afgevoerd te worden.

Redundant Power Supplies



Warning!

This unit might have more than one power supply connection. All connections must be removed to de-energize the unit.

冗長電源装置

このユニットは複数の電源装置が接続されている場合があります。
ユニットの電源を切るためには、すべての接続を取り外さなければなりません。

警告

此部件连接的电源可能不止一个，必须将所有电源断开才能停止给该部件供电。

警告

此装置连接的电源可能不只一个，必须切断所有电源才能停止对该装置的供电。

Warnung

Dieses Gerät kann mehr als eine Stromzufuhr haben. Um sicherzustellen, dass der Einheit kein Strom zugeführt wird, müssen alle Verbindungen entfernt werden.

¡Advertencia!

Puede que esta unidad tenga más de una conexión para fuentes de alimentación. Para cortar por completo el suministro de energía, deben desconectarse todas las conexiones.

Attention

Cette unité peut avoir plus d'une connexion d'alimentation. Pour supprimer toute tension et tout courant électrique de l'unité, toutes les connexions d'alimentation doivent être débranchées.

אם קיים יותר מספק אחד

אזהרה!

ליחידה יש יותר מחיבור אחד של ספק. יש להסיר את כל החיבורים על מנת לרוקן את היחידה.

قد يكون لهذا الجهاز عدة اتصالات بوحدات امداد الطاقة.
يجب إزالة كافة الاتصالات لعزل الوحدة عن الكهرباء

경고!

이 장치에는 한 개 이상의 전원 공급 단자가 연결되어 있을 수 있습니다. 이 장치에 전원을 차단하기 위해서는 모든 연결 단자를 제거해야만 합니다.

Waarschuwing

Deze eenheid kan meer dan één stroomtoevoeraansluiting bevatten. Alle aansluitingen dienen verwijderd te worden om het apparaat stroomloos te maken.

Backplane Voltage



Warning!

Hazardous voltage or energy is present on the backplane when the system is operating. Use caution when servicing.

バックプレーンの電圧

システムの稼働中は危険な電圧または電力が、バックプレーン上にかかっています。

修理する際にはご注意ください。

警告

当系統正在进行时，背板上有很危险的电压或能量，进行维修时务必小心。

警告

當系統正在進行時，背板上有很危險的電壓或能量，進行維修時務必小心。

Warnung

Wenn das System in Betrieb ist, treten auf der Rückwandplatine gefährliche Spannungen oder Energien auf. Vorsicht bei der Wartung.

¡Advertencia!

Cuando el sistema está en funcionamiento, el voltaje del plano trasero es peligroso. Tenga cuidado cuando lo revise.

Attention

Lorsque le système est en fonctionnement, des tensions électriques circulent sur le fond de panier. Prendre des précautions lors de la maintenance.

מתח בפנל האחורי

אזהרה!
קיימת סכנת מתח בפנל האחורי בזמן תפעול המערכת. יש להיזהר במהלך
העבודה.

هناك خطر من التيار الكهربائي أو الطاقة الموجودة على اللوحة
عندما يكون النظام يعمل كن حذرا عند خدمة هذا الجهاز

경고!

시스템이 동작 중일 때 후면판 (Backplane)에는 위험한 전압이나 에너지가 발생
합니다. 서비스 작업 시 주의하십시오.

Waarschuwing

Een gevaarlijke spanning of energie is aanwezig op de backplane wanneer het
systeem in gebruik is. Voorzichtigheid is geboden tijdens het onderhoud.

Comply with Local and National Electrical Codes



Warning!

Installation of the equipment must comply with local and national electrical codes.

地方および国の電気規格に準拠

機器の取り付けはその地方および国の電気規格に準拠する必要があります。

警告

设备安装必须符合本地与本国电气法规。

警告

設備安裝必須符合本地與本國電氣法規。

Warnung

Die Installation der Geräte muss den Sicherheitsstandards entsprechen.

¡Advertencia!

La instalación del equipo debe cumplir con las normas de electricidad locales y
nacionales.

Attention

L'équipement doit être installé conformément aux normes électriques nationales et locales.

תיאום חוקי החשמל הארצי

אזהרה!

התקנת הציוד חייבת להיות תואמת לחוקי החשמל המקומיים והארציים.

تركيب المعدات الكهربائية يجب أن يمتثل للقوانين المحلية والوطنية المتعلقة بالكهرباء

경고!

현 지역 및 국가의 전기 규정에 따라 장비를 설치해야 합니다.

Waarschuwing

Bij installatie van de apparatuur moet worden voldaan aan de lokale en nationale elektriciteitsvoorschriften.

Product Disposal



Warning!

Ultimate disposal of this product should be handled according to all national laws and regulations.

製品の廃棄

この製品を廃棄処分する場合、国の関係する全ての法律・条例に従い処理する必要があります。

警告

本产品的废弃处理应根据所有国家的法律和规章进行。

警告

本產品的廢棄處理應根據所有國家的法律和規章進行。

Warnung

Die Entsorgung dieses Produkts sollte gemäß allen Bestimmungen und Gesetzen des Landes erfolgen.

¡Advertencia!

Al deshacerse por completo de este producto debe seguir todas las leyes y reglamentos nacionales.

Attention

La mise au rebut ou le recyclage de ce produit sont généralement soumis à des lois et/ou directives de respect de l'environnement. Renseignez-vous auprès de l'organisme compétent.

סילוק המוצר

אזהרה!

סילוק סופי של מוצר זה חייב להיות בהתאם להנחיות וחוקי המדינה.

عند التخلص النهائي من هذا المنتج ينبغي التعامل معه وفقا لجميع القوانين واللوائح الوطنية

경고!

이 제품은 해당 국가의 관련 법규 및 규정에 따라 폐기되어야 합니다.

Waarschuwing

De uiteindelijke verwijdering van dit product dient te geschieden in overeenstemming met alle nationale wetten en reglementen.

Hot Swap Fan Warning



Warning!

The fans might still be turning when you remove the fan assembly from the chassis. Keep fingers, screwdrivers, and other objects away from the openings in the fan assembly's housing.

ファン・ホットスワップの警告

シャーシから冷却ファン装置を取り外した際、ファンがまだ回転している可能性があります。ファンの開口部に、指、ドライバー、およびその他のものを近づけないで下さい。

警告

当您从机架移除风扇装置，风扇可能仍在转动。小心不要将手指、螺丝起子和其他物品太靠近风扇

警告

當您從機架移除風扇裝置，風扇可能仍在轉動。小心不要將手指、螺絲起子和其他物品太靠近風扇。

Warnung

Die Lüfter drehen sich u. U. noch, wenn die Lüfterbaugruppe aus dem Chassis genommen wird. Halten Sie Finger, Schraubendreher und andere Gegenstände von den Öffnungen des Lüftergehäuses entfernt.

¡Advertencia!

Los ventiladores podran dar vuelta cuando usted quite el montaje del ventilador del chasis. Mantenga los dedos, los destornilladores y todos los objetos lejos de las aberturas del ventilador

Attention

Il est possible que les ventilateurs soient toujours en rotation lorsque vous retirez le bloc ventilateur du châssis. Prenez garde à ce que doigts, tournevis et autres objets soient éloignés du logement du bloc ventilateur.

אזהרה!

כאשר מסירים את חלקי המאוורר מהמארז, יתכן והמאווררים עדיין עובדים. יש להרחיק למרחק בטוח את האצבעות וכלי עבודה שונים מהפתחים בתוך המאוורר

من الممكن أن المراوح لا تزال تدور عند إزالة كتلة المروحة من الهيكل يجب إبقاء الأصابع ومفكات البراغي وغيرها من الأشياء بعيدا عن الفتحات في كتلة المروحة.

경고!

새시로부터 팬 조립품을 제거할 때 팬은 여전히 회전하고 있을 수 있습니다. 팬 조립품 외관의 열려있는 부분들로부터 손가락 및 스크류드라이버, 다른 물체들이 가까이 하지 않도록 배치해 주십시오.

Waarschuwing

Het is mogelijk dat de ventilator nog draait tijdens het verwijderen van het ventilatorsamenstel uit het chassis. Houd uw vingers, schroevendraaiers en eventuele andere voorwerpen uit de buurt van de openingen in de ventilatorbehuizing.

Power Cable and AC Adapter



Warning!

When installing the product, use the provided or designated connection cables, power cables and AC adaptors. Using any other cables and adaptors could cause a malfunction or a fire. Electrical Appliance and Material Safety Law prohibits the use of UL or CSA -certified cables (that have UL/CSA shown on the code) for any other electrical devices than products designated by Supermicro only.

電源コードとACアダプター

製品を設置する場合、提供または指定された接続ケーブル、電源コードとACアダプターを使用下さい。他のケーブルやアダプタを使用すると故障や火災の原因になることがあります。電気用品安全法は、ULまたはCSA認定のケーブル(UL/CSEマークがコードに表記)をSupermicroが指定する製品以外に使用することを禁止しています。

警告

安装此产品时,请使用本身提供的或指定的连接线,电源线和电源适配器.使用其它线材或适配器可能会引起故障或火灾.除了Supermicro所指定的产品,电气用品和材料安全法律规定禁止使用未经UL或CSA认证的线材。(线材上会显示UL/CSA符号)。

警告

安装此產品時,請使用本身提供的或指定的連接線,電源線和電源適配器.使用其它線材或適配器可能會引起故障或火災.除了Supermicro所指定的產品,電氣用品和材料安全法律規定禁止使用未經UL或CSA認證的線材。(線材上會顯示UL/CSA符號)。

Warnung

Bei der Installation des Produkts, die zur Verfügung gestellten oder benannt Anschlusskabel, Stromkabel und Netzteile. Verwendung anderer Kabel und Adapter kann zu einer Fehlfunktion oder ein Brand entstehen. Elektrische Geräte und Material Safety Law verbietet die Verwendung von UL-oder CSA-zertifizierte Kabel, UL oder CSA auf der Code für alle anderen elektrischen Geräte als Produkte von Supermicro nur bezeichnet gezeigt haben.

¡Advertencia!

Al instalar el producto, utilice los cables de conexión previstos o designados, los cables y adaptadores de CA. La utilización de otros cables y adaptadores podría ocasionar un mal funcionamiento o un incendio. Aparatos Eléctricos y la Ley de Seguridad del Material prohíbe el uso de UL o CSA cables certificados que tienen UL o CSA se muestra en el código de otros dispositivos eléctricos que los productos designados por Supermicro solamente.

Attention

Lors de l'installation du produit, utilisez les bables de connection fournis ou désigné. L'utilisation d'autres cables et adaptateurs peut provoquer un dysfonctionnement ou un incendie. Appareils électroménagers et de loi sur la sécurité Matériel interdit l'utilisation de UL ou CSA cables certifiés qui ont UL ou CSA indiqué sur le code pour tous les autres appareils électriques que les produits désignés par Supermicro seulement.

חשמליים ומתאמי AC

!אזהרה

כאשר מתקינים את המוצר, יש להשתמש בכבלים, ספקים ומתאמים AC אשר נועדו וסופקו לשם כך. שימוש בכל כבל או מתאם אחר יכול לגרום לתקלה או קצר חשמלי. על פי חוקי שימוש במכשירי חשמל וחוקי בטיחות, קיים איסור להשתמש בכבלים המוסמכים ב- UL או ב- CSA (כשאר מופיע עליהם קוד של UL/CSA) עבור כל מוצר חשמלי אחר שלא צויין על ידי סופרמיקרו בלבד.

عند تركيب الجهاز يجب استخدام كابلات التوصيل، والكابلات الكهربائية ومحولات التيار المتردد التي . أن استخدام أي كابلات ومحولات أخرى يتسبب في حدوث عطل أو حريق. تم توفيرها لك مع المنتج الأجهزة الكهربائية ومواد قانون السلامة يحظر استخدام الكابلات CSA أو UL معتمدة من قبل لأي أجهزة كهربائية أخرى غير المنتجات المعينة من قبل Supermicro (التي تحمل علامة UL/CSA)

경고!

제품을 설치할 때에는 제공되거나 지정된 연결케이블과 전원케이블, AC 어댑터를 사용해야 합니다. 그 밖의 다른 케이블들이나 어댑터들은 고장 또는 화재의 원인이 될 수 있습니다. 전기용품안전법 (Electrical Appliance and Material Safety Law)은 슈퍼마이크로에서 지정한 제품들 외에는 그 밖의 다른 전기 장치들을 위한 UL 또는 CSA에서 인증한 케이블(전선 위에 UL/CSA가 표시)들의 사용을 금지합니다.

Waarschuwing

Bij het installeren van het product, gebruik de meegeleverde of aangewezen kabels, stroomkabels en adapters. Het gebruik van andere kabels en adapters kan leiden tot een storing of een brand. Elektrisch apparaat en veiligheidsinformatiebladen wet verbiedt het gebruik van UL of CSA gecertificeerde kabels die UL of CSA die op de code voor andere elektrische apparaten dan de producten die door Supermicro alleen.

Notes

Chapter 5

Advanced Serverboard Setup

This chapter covers the steps required to install the H8DGT-HLIBQF/HLF serverboard into the chassis, connect the data and power cables and install add-on cards. All serverboard jumpers and connections are also described. A layout and quick reference chart are included in this chapter for your reference. Remember to completely close the chassis when you have finished working with the serverboard to better cool and protect the system.

5-1 Handling the Serverboard

Electrostatic discharge (ESD) can damage electronic components. To prevent damage to any printed circuit boards (PCBs), it is important to handle them very carefully (see previous chapter). To prevent the serverboard from bending, keep one hand under the center of the board to support it when handling. The following measures are generally sufficient to protect your equipment from electric static discharge.

Precautions

- Use a grounded wrist strap designed to prevent Electrostatic Discharge (ESD).
- Touch a grounded metal object before removing any board from its antistatic bag.
- Handle a board by its edges only; do not touch its components, peripheral chips, memory modules or gold contacts.
- When handling chips or modules, avoid touching their pins.
- Put the serverboard, add-on cards and peripherals back into their antistatic bags when not in use.
- For grounding purposes, make sure your computer chassis provides excellent conductivity between the power supply, the case, the mounting fasteners and the serverboard.

Unpacking

The serverboard is shipped in antistatic packaging to avoid electrical static discharge. When unpacking the board, make sure the person handling it is static protected.

5-2 Motherboard Installation

This section explains the first step of physically mounting the H8DCT-HLN4F into the SC827 chassis. The 2122TG-H6IBQRF/H6RF is a highly complicated system. It is recommended that motherboard removal/installation be done by a Supermicro trained technician. In case of emergency, following the steps in the order given will eliminate the most common problems encountered in such an installation. To remove the motherboard, follow the procedure in reverse order.

Installing to the Chassis

1. Remove the motherboard tray from the SC827 Chassis body.
2. Make sure that the I/O ports on the motherboard align properly with their respective holes in the I/O shield at the back of the chassis.
3. Carefully mount the motherboard to the motherboard tray by aligning the board holes with the raised metal standoffs that are visible in the chassis.

Caution: Do not slide the motherboard into a tray as this will damage components on the bottom of the board.

4. Insert screws into all the mounting holes on your motherboard that line up with the standoffs and tighten until snug (if you screw them in too tight, you might strip the threads). Metal screws provide an electrical contact to the motherboard ground to provide a continuous ground for the system.
5. Install backplane adapter card into JP3 adapter card connector near the front of motherboard and attach to tray with included screws.
6. Install PCIE x16 Riser Card into PCIE slot & attach to tray with included screw.
7. Finish by replacing motherboard tray into chassis.

Caution: To avoid damaging the motherboard and its components, do not apply any force greater than 8 inch-lbs of torque when installing a screw into a mounting hole.

5-3 I/O Port Connections

The I/O ports are color coded to make setting up your system easier. See Figure 5-1 below for the colors and locations of the various I/O ports.

Figure 5-1. I/O Port Locations and Definitions

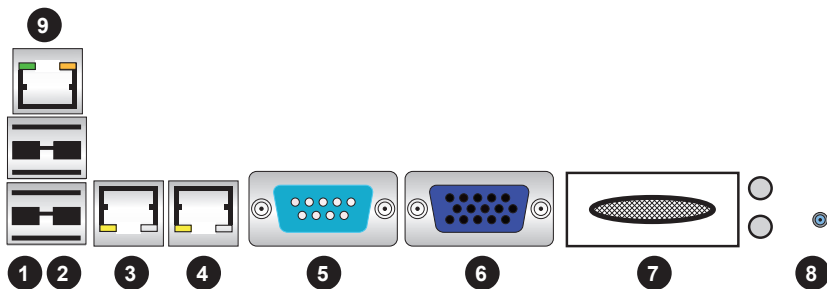

Rear I/O Ports	
1. USB0	6. VGA Port
2. USB1	7. InfiniBand Port (H8DGT-HLIBQF only)
3. LAN1	8. UID
4. LAN2	9. IPMI LAN
5. COM1	

5-4 Processor and Heatsink Installation

Notes:

- When handling the processor, avoid placing direct pressure on the label area of the fan. Also, do not place the serverboard on a conductive surface, which can damage the BIOS battery and prevent the system from booting up.
- Always connect the power cord last and always remove it before adding, removing or changing any hardware components. Make sure that you install the processor into the CPU socket before you install the CPU heatsink.
- If you buy a CPU separately, make sure that you use the heatsink included with the server only.
- Make sure to install the serverboard into the chassis before you install the CPU heatsinks.
- When receiving a serverboard without a processor pre-installed, make sure that the plastic CPU socket cap is in place and none of the socket pins are bent; otherwise, contact your retailer immediately.
- Refer to the Supermicro web site for updates on CPU support.

Installing the Processors

1. Begin by removing the cover plate that protects the CPU. Lift the lever on the CPU socket until it points straight up.



Important! Please save the plastic cap. The serverboard must be shipped with the plastic cap properly installed to protect the CPU socket pins. Shipment without the plastic cap properly installed may cause damage to the socket pins

2. With the lever raised, lift open the silver CPU retention plate. Align the CPU keys with the socket keys.

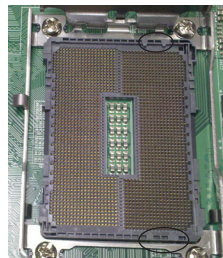

3. Use your thumb and your index finger to hold the CPU. Locate and align pin 1 of the CPU socket with pin 1 of the CPU. Both are marked with a triangle.
4. Align pin 1 of the CPU with pin 1 of the socket. Once aligned, carefully place the CPU into the socket. *Do not drop the CPU on the socket, move the CPU horizontally or vertically or rub the CPU against the socket or against any pins of the socket, which may damage the CPU and/or the socket.*
5. With the CPU inserted into the socket, inspect the four corners of the CPU to make sure that it is properly installed and flush with the socket. Then, gently lower the silver CPU retention plate into place.



Triangle



Caution: The CPU will only seat inside the socket in one direction. Make sure it is properly inserted before closing the load plate. If it doesn't close properly, do not force it as it may damage your CPU. Instead, open the load plate again and double-check that the CPU is aligned properly.

6. Carefully press the CPU socket lever down until it locks into its retention tab. For a dual-CPU system, repeat these steps to install another CPU into the CPU#2 socket.



Note: in single and dual-CPU configurations, memory must be installed in the DIMM slots associated with the installed CPU(s).

Note: see Chapter 6 for details on installing the air shroud.

Note: Supermicro recommends that you utilize a Processor Installation/Removal tool to install or remove the processor from the serverboard without causing the processor or serverboard damage.

Installing a CPU Heatsink

1. Remove power from the system and unplug the AC power cord from the power supply.
2. Do not apply any thermal grease to the heatsink or the CPU die; the required amount has already been applied.
3. Place the heatsink on top of the CPU so that the four mounting holes are aligned with those on the (preinstalled) heatsink retention mechanism.
4. Screw in two diagonal screws (i.e. the #1 and the #2 screws) until just snug. Do not fully tighten the screws or you may damage the CPU.)
5. Add the two remaining screws then finish the installation by fully tightening all four screws.

Note: Make sure the heatsink is placed so that the fins of the heatsink are in the direction of the airflow in your system.

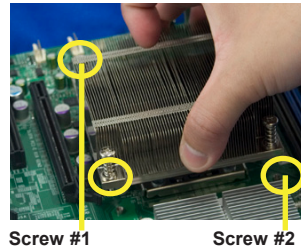
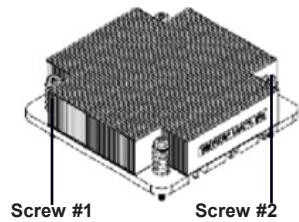

Install Screw #1

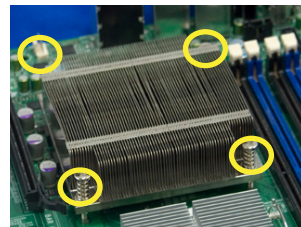
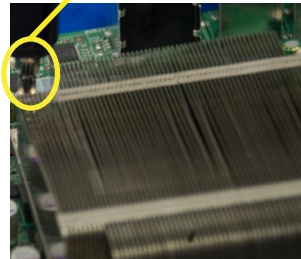

Removing the Heatsink

Caution: We do not recommend that the CPU or the heatsink be removed. However, if you do need to uninstall the heatsink, please follow the instructions below to prevent damage to the CPU or the CPU socket.

1. Remove power from the system and unplug the AC power cord from the power supply.
2. Disconnect the heatsink fan wires from the CPU fan header.
3. Using a screwdriver, loosen and remove the heatsink screws from the motherboard in the sequence as show in the picture on the right.
4. Hold the heatsink as shown in the picture on the right and gently wriggle the heatsink to loosen it from the CPU. (Do not use excessive force when wriggling the heatsink.)
5. Once the heatsink is loose, remove it from the CPU socket.
6. To reinstall the CPU and the heatsink, clean the surface of the CPU and the heatsink to get rid of the old thermal grease. Reapply the proper amount of thermal grease on the CPU surface before reinstalling the heatsink.

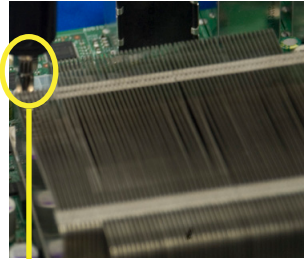

Remove Screw #1

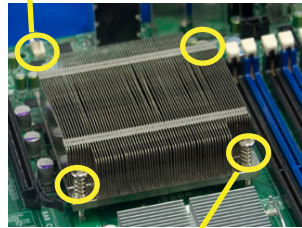

Remove Screw #2

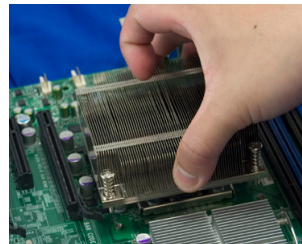

5-5 Installing Memory

Caution: Exercise extreme care when installing or removing DIMM modules to prevent any possible damage.

Installing Memory

1. Insert each memory module vertically into its slot, paying attention to the notch along the bottom of the module to prevent inserting the module incorrectly (see Figure 5-3).
2. Install to slots CPU1/DIMM1A and CPU1/DIMM1B first, then to CPU1/DIMM2A and CPU1/DIMM2B, etc. Always install in pairs and in the numerical order of the DIMM slots. See support information below.
3. Gently press down on the memory module until it snaps into place.
4. With two CPUs installed, repeat step 2 to populate the CPU2 DIMM slots. Always install pairs of DIMMs to both CPU DIMM slots for more efficient operation.

Note: 1 GB, 2 GB, 4 GB, 8 GB or 16 GB size memory modules are supported. It is highly recommended that you remove the power cord from the system before installing or changing memory modules. Please refer to our web site for memory that has been tested on the H8DGT-HLIBQF/HLF serverboard.

Memory Support

The H8DGT-HLIBQF/HLF serverboard supports single/dual/tri/quad channel, DDR3-1600/1333/1066 MHz speed registered ECC/Unbuffered ECC/non-ECC SDRAM.

Populating four adjacent slots at a time with memory modules of the same size and type will result in interleaved (128-bit) memory, which is faster than non-interleaved (64-bit) memory.

Maximum Memory

The H8DGT-HLIBQF/HLF serverboard supports up to 64 GB of ECC/Non-ECC UDIMM or up to 256 GB of ECC RDIMM in eight (8) DIMM slots.

Figure 5-3. DIMM Installation

To Install: Insert module vertically and press down until it snaps into place. Pay attention to the alignment notch at the bottom.

To Remove: Use your thumbs to gently push the release tabs near both ends of the module. This should release it from the slot.

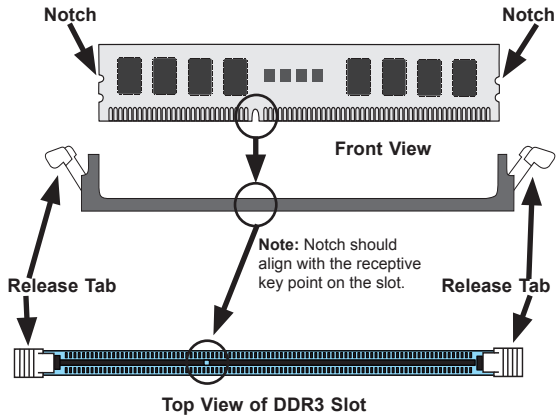

Memory Population for Optimal Performance -For a Motherboard with One CPU (CPU1) Installed					
# DIMMS	CPU	Channel 1	Channel 2	Channel 3	Channel 4
4 DIMMs	CPU1	P1-1A	P1-2A	P1-3A	P1-4A

Memory Population for Optimal Performance -For a Motherboard with Two CPUs (CPU1 & CPU2) Installed					
# DIMMS	CPU	Channel 1	Channel 2	Channel 3	Channel 4
8 DIMMs	CPU1	P1-1A	P1-2A	P1-3A	P1-4A
	CPU2	P2-1A	P2-2A	P2-3A	P2-4A

DIMM Module Population Configuration

For memory to work properly, follow the tables below for memory installation:

Per Channel DIMM Populations Options				
DIMM Type	DIMM A	Max. MHz, 1.5V DIMMs	Max. MHz, 1.35V DIMMs	Max. GB/ Channel
Unbuffered DIMM	SR or DR	1600 MHz	1600 MHz	4 GB
Registered DIMM	SR or DR	1600 MHz	1600 MHz	16 GB
	QR	1333 MHz	1333 MHz	16 GB

Note 1: Due to OS limitations, some operating systems may not show more than 4 GB of memory.

Note 2: Due to memory allocation to system devices, the amount of memory that remains available for operational use will be reduced when 4 GB of RAM is used. The reduction in memory availability is disproportional.

Possible System Memory Allocation & Availability		
System Device	Size	Physical Memory Available (4 GB Total System Memory)
Firmware Hub flash memory (System BIOS)	1 MB	3.99 GB
Local APIC	4 KB	3.99 GB
Area Reserved for the chipset	2 MB	3.99 GB
I/O APIC (4 Kbytes)	4 KB	3.99 GB
PCI Enumeration Area 1	256 MB	3.76 GB
PCI Express (256 MB)	256 MB	3.51 GB
PCI Enumeration Area 2 (if needed) -Aligned on 256-M boundary-	512 MB	3.01 GB
VGA Memory	16 MB	2.85 GB
TSEG	1 MB	2.84 GB
Memory available for the OS & other applications		2.84 GB

5-6 PCI Expansion Cards

The A+ Server 2122TG-H6IBQRF/H6RF includes a preinstalled riser card designed specifically for use in the SC217HQ-R1620BP 2U rackmount chassis for each H8DGT-HLIBQF/HLF serverboard. This riser card supports a low-profile PCI Express 2.0 x16 (up to 6.6") to fit inside the chassis

PCI Card Installation

1. Remove the PCI slot shield on the chassis by releasing the locking tab.
2. Insert the add-on card into the riser card slot.
3. Secure the add-on card with the locking tab.

H8DGT-HLIBQF/HLF Quick Reference

Jumper	Description	Default Setting
JBT1	CMOS Clear	(See Section 5-9)
JB1	InfiniBand Enable/Disable (H8DGT-HLIBQF only)	Pins 1-2 (Enabled)
J ² C1/JI ² C2	I ² C to PCI-E Slot Enable/Disable	Both Closed (Enabled)
JPB1	BMC Enable/Disable	Pins 1-2 (Enabled)
JPG1	VGA Enable/Disable	Pins 1-2 (Enabled)
JPL1	LAN 1/2 Enable/Disable	Pins 1-2 (Enabled)
JWD1	Watch Dog	Pins 1-2 (Reset)

LED	Description
LAN Ports	LEDs for the LAN Ethernet ports
Dedicated IPMI LAN	LEDs for the dedicated IPMI LAN Ethernet port
LE1	LED for UID Button
LE2	InfiniBand Physical Link LED (Green) (H8DGT-HLIBQF only)
LE3	InfiniBand Logical Link LED (Yellow) (H8DGT-HLIBQF only)
DP1	LED for IPMI activity
DP2	LED for Serverboard Power-On

Connector	Description
COM1/COM2	COM1 Serial Port/Header
IPMI LAN	Dedicated IPMI LAN Port
JB1	InfiniBand QSFP Connector (H8DGT-HLIBQF only)
JOH1	Overheat Warning Header
JTPM1	Trusted Platform Module Header
JP3	SMC Proprietary Slot for Power, FP Control & SATA connectors
LAN1/2	Gigabit Ethernet (RJ45) Ports
UID	Unit Identifier Button
USB0/1, USB2/3, USB4	Universal Serial Bus (USB) ports, headers and Type-A ports
VGA	VGA Connector

5-8 Connector Definitions

LAN1/2 (Ethernet Ports)

Two Gigabit Ethernet ports (designated LAN1 and LAN2) are located beside the Serial port. Additionally, there is a dedicated LAN port for IPMI above the two rear USB ports. These Ethernet ports accept RJ45 type cables.



Universal Serial Bus Ports

Two Universal Serial Bus ports (USB 2.0) and one additional Type A port (USB4) are included on the serverboard. See the table on the right for pin definitions.

Universal Serial Bus Ports Pin Definitions (USB0/1, USB4)			
USB0		USB1	
Pin #	Definition	Pin #	Definition
1	+5V	1	+5V
2	PO-	2	PO-
3	PO+	3	PO+
4	Ground	4	Ground

USB Headers

Two USB 2.0 headers (USB2/3) are also included on the motherboard. These may be connected to provide front side access. A USB cable (not included) is needed for the connection. See the table on the right for pin definitions.

Universal Serial Bus Headers Pin Definitions (USB2/3)			
USB2		USB3	
Pin #	Definition	Pin #	Definition
1	+5V	1	+5V
2	PO-	2	PO-
3	PO+	3	PO+
4	Ground	4	Ground
5	Key	5	NC

Note: NC indicates no connection.

Serial Ports

The COM1 serial port is located beside the VGA port. Refer to the motherboard layout for the location of the COM2 header. See the table on the right for pin definitions.

Serial Port Pin Definitions (COM1/COM2)			
Pin #		Definition	
1	DCD	6	DSR
2	RXD	7	RTS
3	TXD	8	CTS
4	DTR	9	RI
5	Ground	10	NC

Note: NC indicates no connection.

Overheat LED

Connect an LED to the JOH1 header to provide warning of chassis overheating. See the table on the right for pin definitions.

Overheat LED Pin Definitions (JOH1)	
Pin#	Definition
1	3.3V
2	OH Active

Unit Identifier Button

A Unit Identifier (UID) button is located on the rear of the board. There is another UID button located on the control panel. When you push either UID button, both Rear UID and Front Panel UID Indicators will illuminate. Push either button again to turn off both indicators. These UID indicators provide easy identification of a system unit that may be in need of service.

UID Button Pin Definitions	
Pin#	Definition
1	Ground
2	Ground
3	Button In
4	Ground

Video Connector

A Video (VGA) connector is located below the COM Port on the IO backplane. This connector is used to provide video and CRT display.

Trusted Platform Module Header

This header is used to connect a Trusted Platform Module (TPM), available separately from a third-party vendor. A TPM is a security device that allows encryption and authentication of hard drives, disallowing access if the TPM associated with it is not installed in the system. See the table on the right for pin definitions.

Trusted Platform Module Header Pin Definitions (JTPM1)			
Pin#	Definition	Pin#	Definition
1	LCLK		GND
3	LFRAME		No Pin
5	LRESET		VCC5
7	LAD3		LAD2
9	VCC3		LAD1
11	LAD0		GND
13	RSV0		RSV1
15	SB3V		SERIRQ
17	GND		CLKRUN
19	LPCPD		RSV2

JP3 Adapter Card Connector

JP3 Adapter card connector slot provides front access to the power supply, serial ATA and Front Panel Control connections for the H8DGT series motherboards. Plug an Adapter card into this connector to use the functions indicated above. This connector is designed specifically for a Supermicro-proprietary adapter card.

InfiniBand Connector (2122TG-H6IBQRF only)

The H8DGT-HLIBQF serverboard includes a single QDR (quad data rate) speed InfiniBand QSFP connector located at JB1 on the serverboard.

The JIB1 jumper must be enabled to use the InfiniBand connector on the serverboard (see section 5-10). LED indicators on the board indicate use and activity on the InfiniBand connector (see section 5-11 for details).

SXB1 Adapter Card Slot/Connector

A PCI-Express 2.0 x8 (in x4) slot (SXB1) is located at JPCIE2 on the motherboard. This slot is used for an SMC proprietary SAS adapter card.

5-9 Jumper Settings

Explanation of Jumpers

To modify the operation of the motherboard, jumpers can be used to choose between optional settings. Jumpers create shorts between two pins to change the function of the connector. Pin 1 is identified with a square solder pad on the printed circuit board. See the diagram at right for an example of jumping pins 1 and 2. Refer to the motherboard layout page for jumper locations.

Note: On two-pin jumpers, "Closed" means the jumper is on and "Open" means the jumper is off the pins.

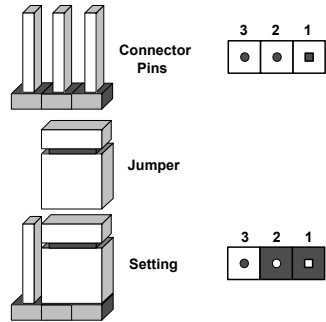

JBT1 contact pads

CMOS Clear

JBT1 is used to clear CMOS, which will also clear any passwords. Instead of pins, this jumper consists of contact pads to prevent accidentally clearing the contents of CMOS.

To Clear CMOS

1. First power down the system and unplug the power cord(s).
2. With the power disconnected, short the CMOS pads with a metal object such as a small screwdriver.
3. Remove the screwdriver (or shorting device).
4. Reconnect the power cord(s) and power on the system.

Note: Do not use the PW_ON connector to clear CMOS.

InfiniBand Enable/Disable (H8DGT-HLIBQF only)

The JIB1 jumper allows you to enable or disable the InfiniBand connector. The default position is on pins 1 and 2 to enable the InfiniBand connector. See the table on the right for jumper settings.

InfiniBand Connector Enable/Disable Jumper Settings (JPG1)	
Jumper Setting	Definition
Pins 1-2	Enabled
Pins 2-3	Disabled

I²C to PCI-Express Slot

J1²C1/J1²C2 allows you to enable the I²C bus to communicate with the PCI-Express slot. For the jumpers to work properly, please set both jumpers to the same setting. If enabled, both jumpers must be enabled. If disabled, both jumpers must be disabled. See the table on the right for jumper settings.

I ² C to PCI-Express Slot Jumper Settings (J1 ² C1/J1 ² C2)	
Jumper Setting	Definition
Closed	Enabled
Open	Disabled

Watch Dog Enable/Disable

JWD enables the Watch Dog function, a system monitor that takes action when a software application freezes the system. Jumping pins 1-2 will have WD reboot the system if a program freezes. Jumping pins 2-3 will generate a non-maskable interrupt for the program that has frozen. See the table on the right for jumper settings. Watch Dog must also be enabled in BIOS.

Watch Dog Jumper Settings (JWD)	
Jumper Setting	Definition
Pins 1-2	Reset
Pins 2-3	NMI
Open	Disabled

Note: when Watch Dog is enabled, the user must write their own application software to disable the Watch Dog Timer.

VGA Enable/Disable

JPG1 allows you to enable or disable the VGA port. The default position is on pins 1 and 2 to enable VGA. See the table on the right for jumper settings.

VGA Enable/Disable Jumper Settings (JPG1)	
Jumper Setting	Definition
Pins 1-2	Enabled
Pins 2-3	Disabled

BMC Jumper

JPB is used to enable or disable the BMC (Baseboard Management Control) Chip and the onboard IPMI connection. This jumper is used together with the IPMI settings in the BIOS. The default position is on pins 1 and 2 to Enable BMC. See the table on the right for jumper settings.

BMC Jumper Enable (JPB) Jumper Settings	
Jumper Setting	Definition
Pins 1-2	Enabled (default)
Pins 2-3	Disabled

LAN1/2 Enable/Disable

Change the setting of jumper JPL1 to enable to enable or disable the LAN1 and LAN2 Ethernet ports. See the table on the right for jumper settings. The default setting is enabled.

LAN1/2 En/Disable Jumper Settings (JPL1)	
Jumper Setting	Definition
Pins 1-2	Enabled
Pins 2-3	Disabled

5-10 Onboard Indicators

LAN LEDs

The Ethernet ports (located beside the VGA port) have two LEDs. On each Gb LAN port, one LED blinks to indicate activity while the other may be green, amber or off to indicate the speed of the connection. See the table on the right for the functions associated with the connection speed LED.

LAN LED (Connection Speed Indicator)	
LED Color	Definition
Off	10 MHz
Green	100 MHz
Amber	1 GHz

Dedicated IPMI LAN LEDs

A dedicated IPMI LAN is also included on the H8DGT-HLIBQF/HLF serverboard. The amber LED on the right of the IPMI LAN port indicates activity, while the green LED on the left indicates the speed of the connection. See the table at right for more information.

IPMI LAN Link LED (Left) & Activity LED (Right)		
Color	Status	Definition
Link (Left)	Green: Solid	100 Mb/s
Activity (Right)	Amber: Blinking	Active

IPMI LED

The serverboard contains an IPMI LED (DP1) located near the corner above the PCI-X slots. When this LED is lit, it means a connection is active for the built-in IPMI on the serverboard.

Note: This LED is not installed on non-IPMI boards.

IPMI LED (DP1)	
State	System Status
On	Active connection
Off	No connection

Power LED

DP2 is an Onboard Power LED. When this LED is lit, it means power is present on the serverboard. Be sure to turn off the system and unplug the power cord(s) before removing or installing components.

Power LED (DP2)	
State	System Status
On	Standby power present on motherboard
Off	No power connected

InfiniBand LED Indicators

Two InfiniBand LED indicators (LE2/LE3) are located near the InfiniBand port of the H8DGT-HLIBQF serverboard. The green LED (LE2) is the InfiniBand link LED while the yellow LED (LE3) indicates activity. Refer to the tables at the right for details.

InfiniBand LED (LE2) Activity LED		
Color	Status	Definition
Green	Solid	InfiniBand Connected
Off	Off	No Connection

InfiniBand LED (LE3) Activity LED		
Color	Status	Definition
Yellow	Solid	InfiniBand Active
Yellow	Dim	InfiniBand Connected, Activity Idle
Off	Off	No Connection

UID LED (LE1)

A rear UID LED Indicator, located at LE1, works in conjunction with the rear UID switch to provide easy identification for a unit that might be in need of service. Refer to Page 2-13 for further UID details.

5-11 Enabling SATA RAID

Now that the hardware is set up, you must install the operating system and the SATA RAID drivers, if you wish to use RAID with your SATA drives. The installation procedure differs depending on whether you wish to have the operating system installed on a RAID array or on a separate non-RAID drive. See the instructions below for details.

Serial ATA (SATA)

Serial ATA (SATA) is a physical storage interface that employs a single cable with a minimum of four wires to create a point-to-point connection between devices. This connection is a serial link that supports a SATA transfer rate from 300 MBps. The serial cables used in SATA are thinner than the traditional cables used in Parallel ATA (PATA) and can extend up to one meter in length, compared to only 40 cm for PATA cables. Overall, SATA provides better functionality than PATA.

Installing the OS/SATA Driver

Before installing the OS (operating system) and SATA RAID driver, you must decide if you wish to have the operating system installed as part of a bootable RAID array or installed to a separate non-RAID hard drive. If on a separate drive, you may install the driver either during or after the OS installation. If you wish to have the OS on a SATA RAID array, you must follow the procedure below and install the driver during the OS installation.

Building a Driver Diskette

You must first build a driver diskette from the Supermicro CD-ROM that was included with the system. (You will have to create this disk on a computer that is already running and with the OS installed.)

Note: Window's Vista, Windows 2008 or later Windows OS systems can use a USB stick instead of a floppy. For older systems, you must have an external USB floppy when building the driver diskette.

Building a Driver Diskette

1. Insert the CD into your CD-ROM drive and start the system. A display as shown in Figure 5-8 will appear.
2. Click on the icon labeled "Build Driver Diskettes and Manuals" and follow the instructions to create a floppy disk with the driver on it.
3. Once it's been created, remove the floppy and insert the installation CD for the Windows Operating System you wish to install into the CD-ROM drive of the new system you are about to configure.

Enabling SATA RAID in the BIOS

Before installing the Windows operating system, you must change some settings in the BIOS. Boot up the system and hit the <Delete> key to enter the BIOS Setup Utility. After the setup utility loads,

1. Use the arrow keys to move to the "Exit" menu. Scroll down using the arrow keys to "Load Optimal Defaults" and press <Enter>. Select "OK" to confirm, then <Enter> to load the default settings.
2. Use the arrow keys to move to the "Advanced" menu, then scroll down to "IDE configuration". On this submenu, scroll down to "OnChip SATA Type" and choose the "RAID" option (Figure 5-5). "RAID Codebase" submenu appears. This setting allows you to select the codebase for your RAID setup. Options are either Adaptec or DoHill.

Figure 5-5. BIOS Setup Screen



3. Press the <Esc> key twice and scroll to the "Exit" menu. Select "Save Changes and Exit" and press <Enter>, then press <Enter> again to verify.
4. After exiting the BIOS Setup Utility, the system reboots. When prompted during the startup, to use the DoHill RAID Utility program press <CTRL+R> (Figure 5-6), or to use the Adaptec RAID Utility program press <CTRL+A> (Figure 5-7).

Figure 5-6. DotHill RAID Utility Program Screen

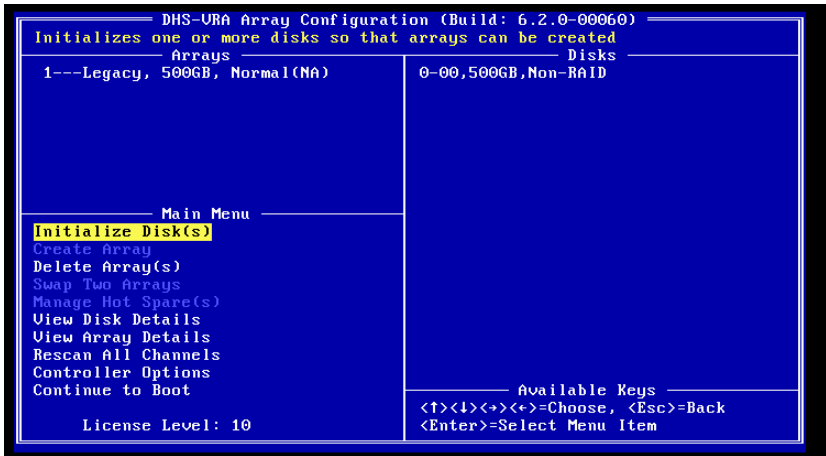
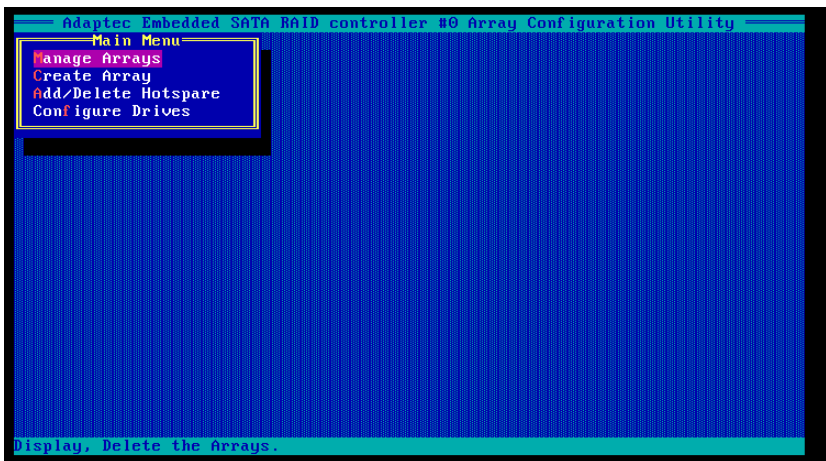

Figure 5-7. Adaptec RAID Utility Program Screen



Using the DotHill and Adaptec RAID Utility

The RAID Utility program allows you to define the drives you want to include in the RAID array and the mode and type of RAID.

Installing the RAID Driver During OS Installation

You may also use the procedure below to install the RAID driver during the Windows OS installation:

1. With the Windows OS installation CD-ROM in the CD drive, restart the system.
2. Press <Enter> again to continue with the Windows setup.
3. When you see the prompt, hit the <F6> key to enter Windows setup.
4. Eventually a blue screen will appear with a message that begins “Windows could not determine the type of one or more storage devices . . .” When you see the screen, hit the <S> key to “Specify Additional Device”, then insert the driver diskette you just created into the floppy drive.
5. Highlight “Manufacturer Supplied Hardware Support Disk” and hit the <Enter> key.
6. Highlight the first “Adaptec RAID” driver shown and press the <Enter> key to install it.

5-13 Installing Software

The Supermicro ftp site contains drivers and utilities for your system at <ftp://ftp.supermicro.com>. Some of these must be installed, such as the chipset driver.

After accessing the ftp site, go into the CDR_Images directory and locate the ISO file for your motherboard. Download this file to create a CD/DVD of the drivers and utilities it contains. (You may also use a utility to extract the ISO file if preferred.)

Another option is to go to the Supermicro Website at <http://www.supermicro.com/products/>. Find the product page for your motherboard here, where you may download individual drivers and utilities.

After creating a CD/DVD with the ISO files, insert the disk into the CD/DVD drive on your system and the display shown in Figure 5-8 should appear.

Figure 5-8. Driver/Tool Installation Display Screen

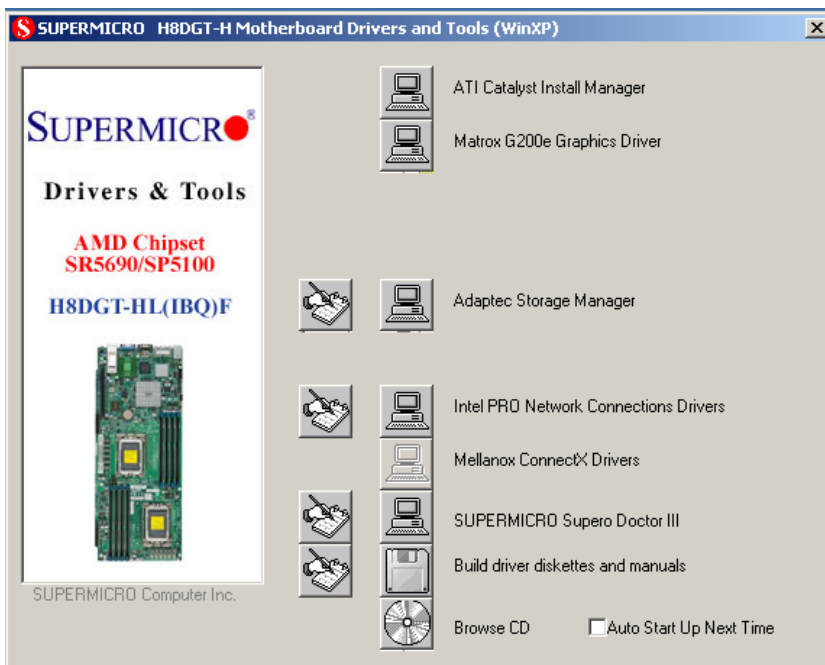

Note: Click the icons showing a hand writing on paper to view the readme files for each item. Click the computer icons to the right of these items to install each item (from top to the bottom) one at a time. After installing each item, you must reboot the system before moving on to the next item on the list. The bottom icon with a CD on it allows you to view the entire contents.

SuperDoctor III

The SuperDoctor® III program is a web-based management tool that supports remote management capability. It includes Remote and Local Management tools. The local management is called SD III Client. The SuperDoctor III program allows you to monitor the environment and operations of your system. SuperDoctor III displays crucial system information such as CPU temperature, system voltages and fan status. See the figures below for examples of the SuperDoctor III interface.

Note: The default User Name and Password for SuperDoctor III is ADMIN / ADMIN.

Note: When SuperDoctor III is first installed, it adopts the temperature threshold settings that have been set in BIOS. Any subsequent changes to these thresholds must be made within SuperDoctor III, as the SuperDoctor III settings override the BIOS settings. To set the BIOS temperature threshold settings again, you would first need to uninstall SuperDoctor III

Figure 5-9. SuperDoctor III Interface Display Screen (Health Information)



Figure 5-10. SuperDoctor III Interface Display Screen (Remote Control)



5-13 Serverboard Battery

Caution: There is a danger of explosion if the onboard battery is installed upside down, which will reverse its polarities (see Figure 5-11). This battery must be replaced only with the same or an equivalent type recommended by the manufacturer (CR2032). Dispose of used batteries according to the manufacturer's instructions.

Figure 5-11. Installing the Onboard Battery

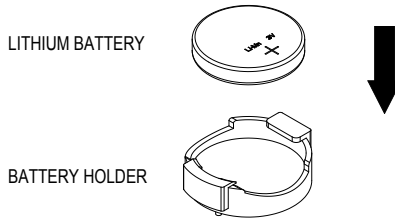

Please handle used batteries carefully. Do not damage the battery in any way; a damaged battery may release hazardous materials into the environment. Do not discard a used battery in the garbage or a public landfill. Please comply with the regulations set up by your local hazardous waste management agency to dispose of your used battery properly.

Chapter 6

Advanced Chassis Setup

This chapter covers the steps required to install components and perform maintenance on the SC217HQ-R1620BP chassis. For component installation, follow the steps in the order given to eliminate the most common problems encountered. If some steps are unnecessary, skip ahead to the step that follows.

Tools Required: The only tool you will need to install components and perform maintenance is a Philips screwdriver.

6-1 Static-Sensitive Devices

Electrostatic discharge (ESD) can damage electronic components. To prevent damage to any printed circuit boards (PCBs), it is important to handle them very carefully. The following measures are generally sufficient to protect your equipment from ESD damage.

Precautions

- Use a grounded wrist strap designed to prevent static discharge.
- Touch a grounded metal object before removing any board from its antistatic bag.
- Handle a board by its edges only; do not touch its components, peripheral chips, memory modules or gold contacts.
- When handling chips or modules, avoid touching their pins.
- Put the serverboard, add-on cards and peripherals back into their antistatic bags when not in use.
- For grounding purposes, make sure your computer chassis provides excellent conductivity between the power supply, the case, the mounting fasteners and the serverboard.

Unpacking

The serverboard is shipped in antistatic packaging to avoid static damage. When unpacking the board, make sure the person handling it is static protected.

Figure 6-1. Front and Rear Chassis Views

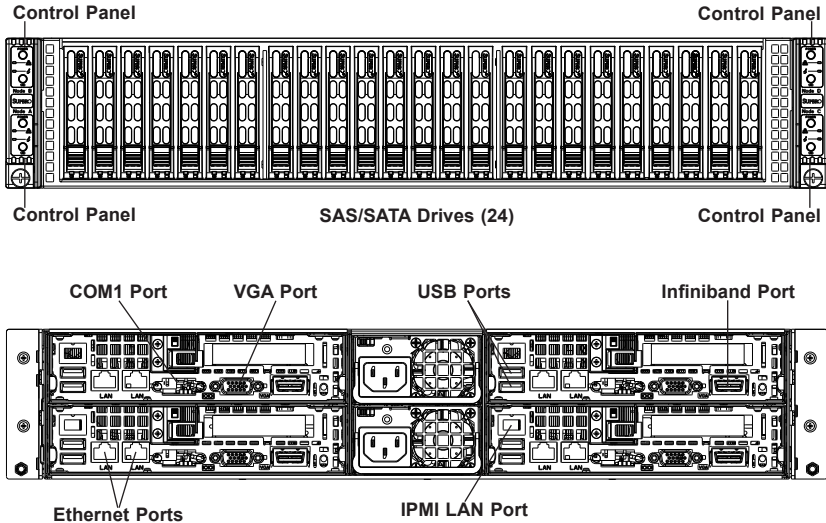

6-2 Control Panel

The control panel (located on the front of the chassis) must be connected to the chassis backplane connector on the serverboard to provide you with system status indications. A ribbon cable has bundled these wires together to simplify the connection. Connect the cable from the control panel to the chassis backplane. Pull all excess cabling out of the airflow path. The LEDs inform you of system status.

See Chapter 3 for details on the LEDs and the control panel buttons.

6-3 Chassis Cover

Before operating the SC217 chassis for the first time, it is important to remove the protective film covering the top of the chassis, in order to allow for proper ventilation and cooling.

Removing the Chassis Cover and Protective Film (Figure 6-2)

1. Unplug the AC power cord from any external power source.
2. Remove the two screws which secure the top cover onto the chassis as shown above.
3. Lift the top cover up and off the chassis.
4. Peel off the protective film covering the top cover and the top of the chassis
5. Check that all ventilation openings on the top cover and the top of the chassis are clear and unobstructed.
6. Replace the chassis cover and reconnect the AC power cord.

Figure 6-2. Removing the Chassis Cover

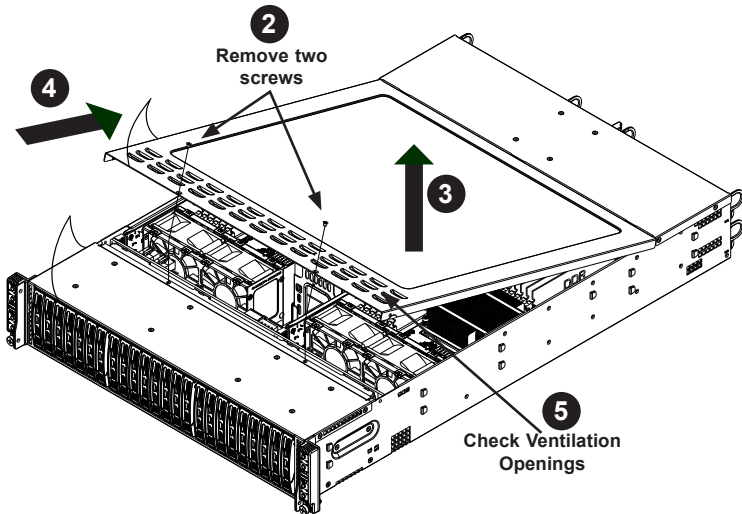

Caution: Except for short periods of time, do NOT operate the server without the cover in place. The chassis cover must be in place to allow proper airflow and prevent overheating.

6-4 Air Shrouds

Air shrouds concentrate airflow to maximize fan efficiency. The SC217 chassis requires air shrouds for each motherboard node. Air shrouds vary depending upon the motherboard used. See the illustrations below.

Installing an Air Shroud (Figure 6-3)

1. Make sure that the motherboard expansion card (if applicable) and all components are properly installed in each motherboard node.
2. Place the first air shroud over the motherboard, as shown below. The air shroud sits behind the system fans and goes over the top of the motherboard and its components.
3. Repeat the procedure for the remaining three motherboard nodes.

Figure 6-3. Installing the Air Shroud

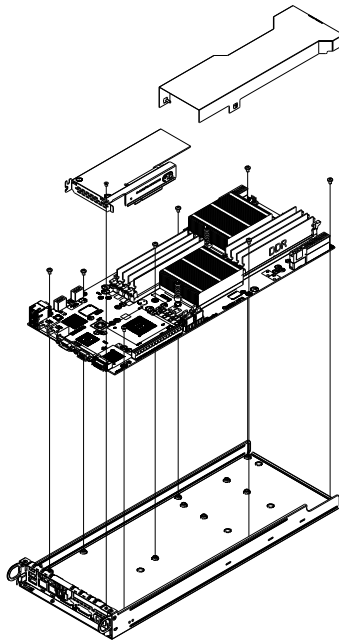

Installation Complete

In most cases, the chassis power supply and fans are pre-installed. If you need to install fans or power supplies, continue to the Systems Fan and Power Supply sections of this chapter. If the chassis will be installed into a rack, continue to the next chapter for rack installation instructions.

6-5 System Fans

Four fans provide cooling for the chassis. These fans circulate air through the chassis as a means of lowering the chassis internal temperature. They system fans are easy to change modules. There is no need to uninstall any other parts inside the system when replacing fans, and no tools are required for installation. They are *not* hot-swappable.

Optional Fan Configurations

The SC217H model chassis is designed so that the default configuration of the system is for each motherboard to control two fans. Each motherboard node in the chassis is connected to the backplane through the adapter card, mounted in the motherboard node drawer. In the event that one of the motherboard drawers is removed, then the remaining motherboard will operate both fans.

Fan Configurations Options
SC217H Hot-Swappable Default Configuration
Fans A and B connected to backplane, backplane connected to Node A and B by adapter card
Fans C and D connected to backplane, backplane connected to Nodes A and B by adapter card

Changing a System Fan

1. If necessary, open the chassis while the power is running to determine which fan has failed. (Never run the server for an extended period of time with the chassis cover open.)
2. Remove the failed fan's power cord from the backplane.
3. Lift the fan housing up and out of the chassis.
4. Push the fan up from the bottom and out of the top of the housing.

5. Place the replacement fan into the vacant space in the housing while making sure the arrows on the top of the fan (indicating air direction) point in the same direction as the arrows on the other fans (see Figure 6-4).

Figure 6-4. Replacing a System Fan in the Fan Housing

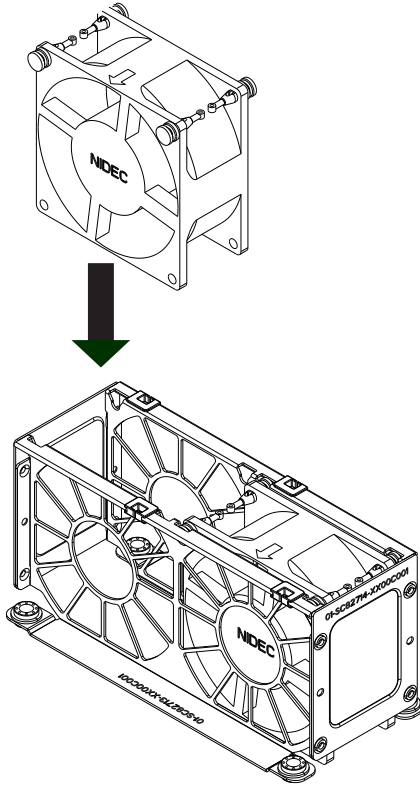

- Put the fan back into the chassis and reconnect the cable (Figure 6-5).

Figure 6-5. System Fan Placement

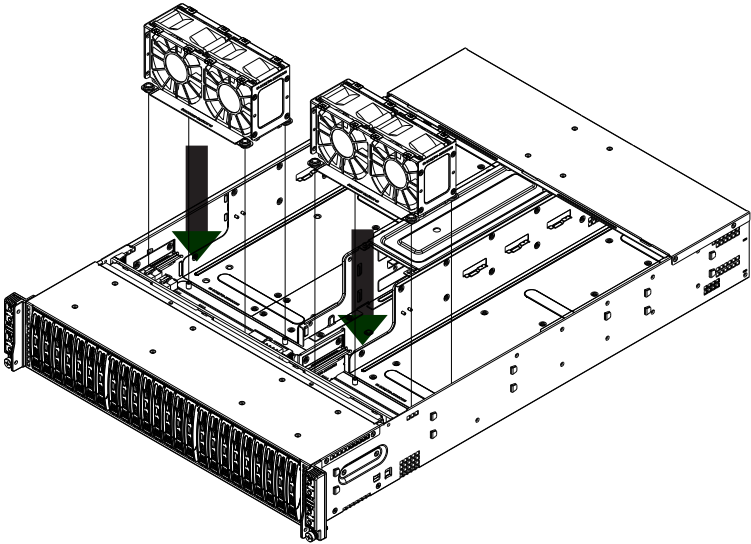

- Confirm that the fan is working properly before replacing the chassis cover.

6-6 Removing and Installing the Backplane

The SC217 chassis backplane is located behind the hard drives and in front of the front system fans. Although backplane failure rarely occurs, in the event of a backplane failure, follow the instructions below.

Removing the Backplane

Removing the Backplane from the Chassis

1. Power down and unplug the system from any power source.
2. Remove the chassis cover.
3. Disconnect the cabling to the backplane.
4. Remove all of the hard drive carriers from the front of the chassis.
5. Remove the upper screws at the top of the backplane and the screw from the side of the chassis, as indicated by the arrows below (Figure 6-6).

Figure 6-6. Removing the Screws at the Top of the Backplane

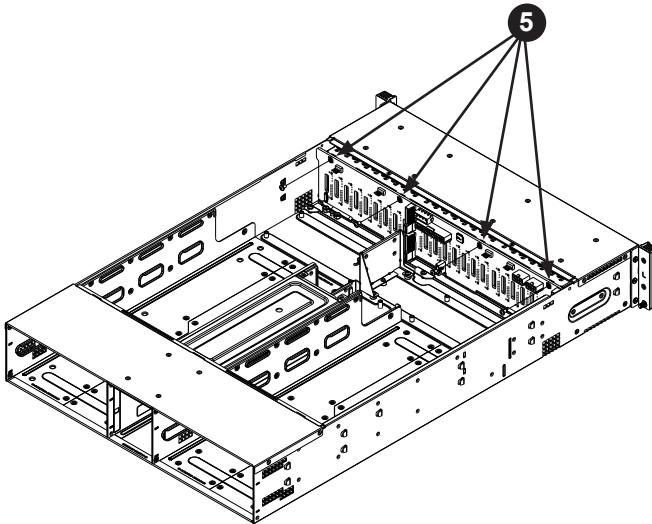

- Loosen the three screws in the spring bar, located on the floor of the chassis, indicated by the arrows below (Figure 6-7).
- Remove the side screw from the side of the chassis.

Figure 6-7. Loosening the Spring Bar Screws in the Floor of the Chassis

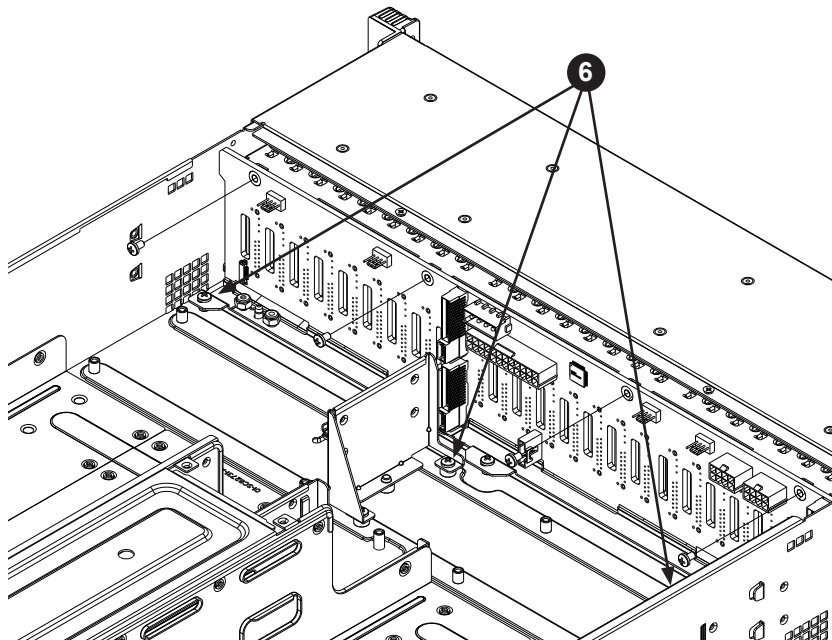

- Gently ease the backplane up and out of the chassis at a slight angle.

Figure 6-8. Removing the Backplane from the Chassis

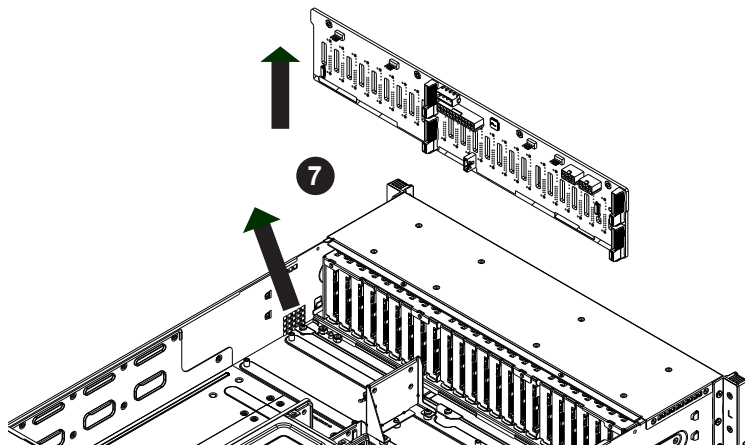

Installing the Backplane

Installing the Backplane into the Chassis (Figure 6-9)

1. Ensure that all of the hard drive carriers have been removed from the bays in the front of the chassis and that the spring bar has been loosened as directed in the previous section.
2. Secure the side mounting bracket to the backplane with the two screws provided.
3. Slide the backplane into the chassis at a slight angle, pushing it up against the side of the chassis.
4. Ease the backplane forward, against the front of the chassis. This will aid in the alignment of the mounting holes.
5. Align the mounting holes in the backplane with the holes in the chassis. Replace the four screws at the top of the backplane and the screw on the side of the chassis.
6. Adjust the spring bar, then tighten the spring bar screws in the floor of the chassis.
7. Replace the side screw in the side of the chassis.
8. Reconnect all cables and return the hard drive carriers to their bays in the front of the chassis.
9. Replace the chassis cover and power-up the system.

Figure 6-9. Installing the Backplane

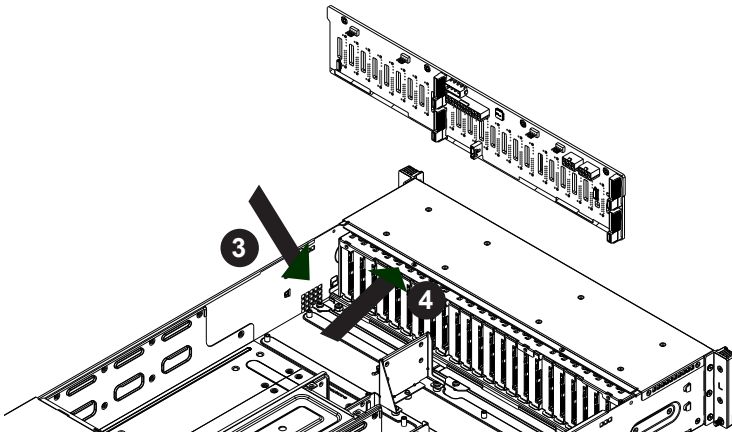

6-7 Installing the Motherboard

I/O Shield

The I/O shield holds the motherboard ports in place (Figure 6-10). The I/O shield does not require installation.

Figure 6-10. I/O Shield Placement

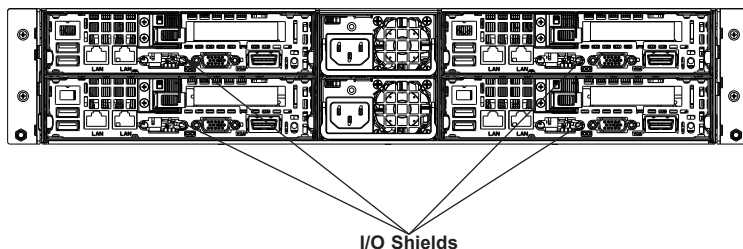

Permanent and Optional Standoffs

Standoffs prevent short circuits by creating space between the motherboard and the chassis surface. The SC217 chassis includes permanent standoffs in locations used by the motherboards. These standoffs accept the rounded Phillips head screws included in the SC217 accessories packaging.

Some motherboards require additional screws for heatsinks, general components and/or non-standard security. Optional standoffs are used for these motherboards.

To use an optional standoff, you must place a hexagonal screw through the bottom the chassis and secure the screw with the hexagonal nut (rounded side up).

Depending upon the configuration of the motherboard being used, it is also possible that some of the optional standoffs which are pre-installed in the chassis, may need to be removed.

Installing the Motherboard (Figure 6-11)

1. Review the documentation that came with your motherboard. Become familiar with component placement, requirements, precautions, and cable connections.
2. Disconnect the AC power cord from any power source.
3. Pull the motherboard node drawer out of the back of the chassis.
4. Remove the add-on card brackets:
 - a. Remove screw securing the add-on card bracket to the back of the node drawer.
 - b. Lift the bracket out of the node drawer.

5. Make sure that the I/O ports on the serverboard align properly with their respective holes in the I/O shield at the back of the chassis.
6. Lay the motherboard in the node drawer aligning the standoffs with the motherboard.

Caution: Do not slide serverboard into the tray as this will damage components on the bottom of the serverboard.

7. Secure the motherboard to the node drawer using the rounded, Phillips head screws included for this purpose. Line up with the standoffs and tighten until snug. Metal screws provide an electrical contact to the motherboard ground to provide a continuous ground for the system.

Caution: To avoid damaging the motherboard and its components, do not apply any force greater than 8 inch-lbs. of torque when installing a screw into a mounting hole.

8. Install the adapter card associated with the motherboard if the chassis is a hot-swappable version. Refer to the next section for instructions on installing the adapter card
9. Secure the CPU(s), heatsinks, and other components to the motherboard as described in the motherboard documentation.
10. Connect the cables between the motherboard, backplane, chassis, front panel, and power supply, as needed. Also, fans may be temporarily removed to allow access to the backplane ports.
11. Replace the add-on card bracket and secure the bracket with a screw.
12. Repeat steps 3 - 11 for the remaining nodes.
13. Connect the AC power cord and power up the system.

Figure 6-11. Installing the Motherboard in the Motherboard Node Drawer

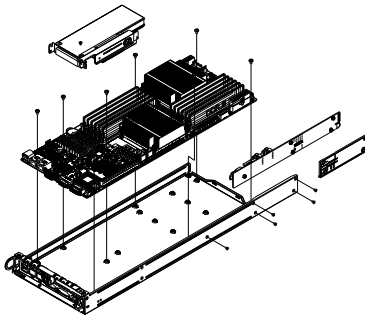

Note: The node drawing is an example only, actual layout differs slightly.

6-8 Adapter Card Replacement

Each motherboard drawer comes equipped with an adapter card which plugs into the backplane. In the unlikely event that the adapter card needs to be replaced, installation requires only a Phillips head screwdriver.

Removing the Adapter Card (Figure 6-12)

1. Disconnect the AC power cord from any power source.
2. Remove the motherboard drawer from the chassis.
3. Disconnect the wiring, connecting the adapter card to the motherboard if any is present.
4. Remove the five screws securing the adapter card and the spacer plate to the drawer and set them aside for later use.
5. Remove the adapter card and spacer plate from the motherboard drawer.
6. Set the spacer plate aside for later use.

Installing the Adapter Card (Figure 6-12)

1. Make sure the motherboard has been installed properly in the node drawer before installing the adapter card
2. Place the adapter card and spacer plate in the motherboard drawer, aligning the holes in the spacer and the adapter card with the holes in the motherboard drawer.
3. Secure the adapter card and spacer plate to the motherboard drawer, using the five M3 flathead screws which were previously set aside.
4. Reconnect the wiring from the motherboard to the adapter card if necessary.
5. Return the motherboard drawer to the closed position in the chassis.

Figure 6-12. Adapter Card Installation

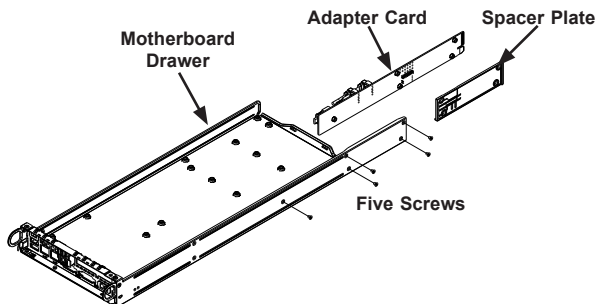

Add-on Card/Expansion Slot Setup

The SC217 chassis supports one low-profile expansion slot for each node, for a total of four slots in the chassis (Figure 6-13). To install a low-profile PCI card, follow the following instructions.

Figure 6-13. PCI Slot Shield and Add-on Card Slot Clip

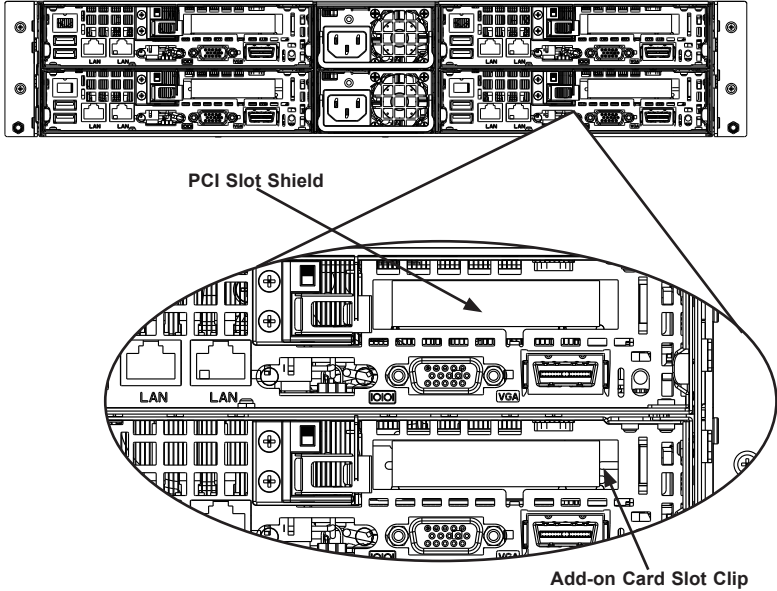

Installing Add-on Cards (Figure 6-14)

1. Disconnect the chassis from any power source, lay the chassis on a flat surface, and open the chassis cover.
2. Pull open the add-on card slot clip in the rear of the chassis.
3. Slide the temporary PCI slot shield toward the slot clip and remove the temporary slot shield from the chassis.
4. Connect the add-on card to the riser card.
5. Secure the riser card to the motherboard tray using the riser card screw.
6. Slide the add-on card bracket into the rear add-on card slot and secure it with the add-on card bracket screws
7. Close the add-on card slot clip.

Note: Under normal circumstances, the riser card and add-on card bracket are not separated.

Figure 6-14: Installing the Expansion Card

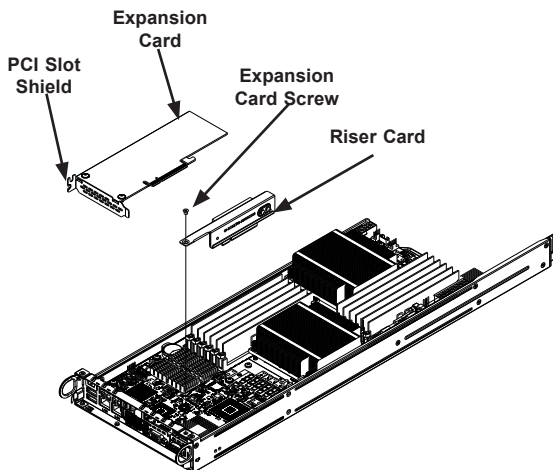

Important! The Motherboard Node Drawer only accepts add-on cards up to 6.6" (167.64 mm) in length.

6-9 Hard Disk Drives

The SC217 chassis features 24 drive bays that are accessible for drive replacement from the front of the chassis. The drives are mounted in drive carriers to simplify their installation and removal. These carriers also help promote proper airflow for the drive bays.

The chassis contains four individual motherboards in separate node drawers. Each motherboard node controls a set of six hard drives. Note that if a motherboard node drawer is pulled out of the chassis, the hard drives associated with that node will power down as well.

Motherboard Drawer Locations in the Chassis	
Motherboard B Controls HDDs B1-B6	Motherboard D Controls HDDs D1-D6
Motherboard A Controls HDDs A1-A6	Motherboard C Controls HDDs C1-C6

Figure 6-15. Hard Drives and the Corresponding Motherboards

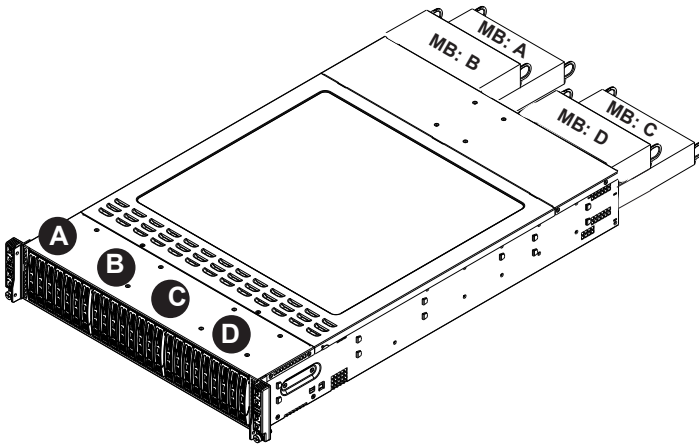

Note: Enterprise level hard disk drives are recommended for use in Supermicro chassis and servers. For information on recommended HDDs, visit the Supermicro Web site at <http://www.supermicro.com/products/nfo/files/storage/SAS-CompList.pdf>

Removing Hard Drive Carriers from the Chassis

1. Press the release button on the drive carrier. This extends the drive bay handle.
2. Use the handle to pull the drive out of the chassis (Figure 6-16).
3. Remove the dummy drive from the carrier (Figure 6-17).

Figure 6-16. Removing a Hard Drive

Figure 6-17. Removing a Dummy Drive from Carrier



Installing a Drive into the Carrier

1. Install a new drive into the carrier with the printed circuit board side facing down so that the mounting holes in the drive align with those in the carrier.
2. Secure the hard drive into the carrier with the screws.

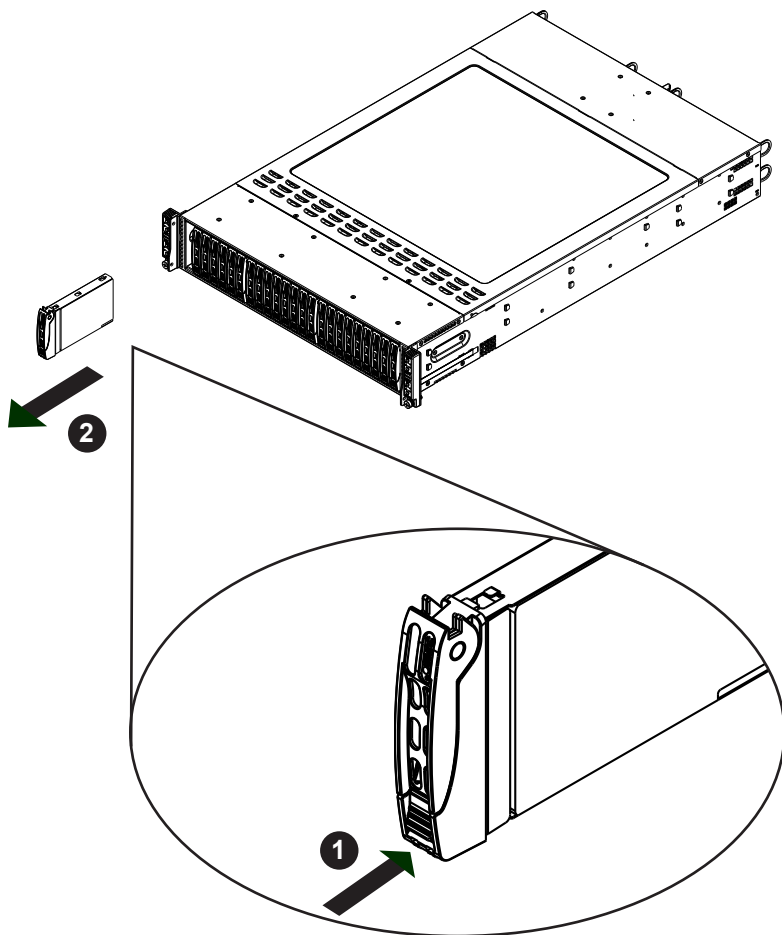
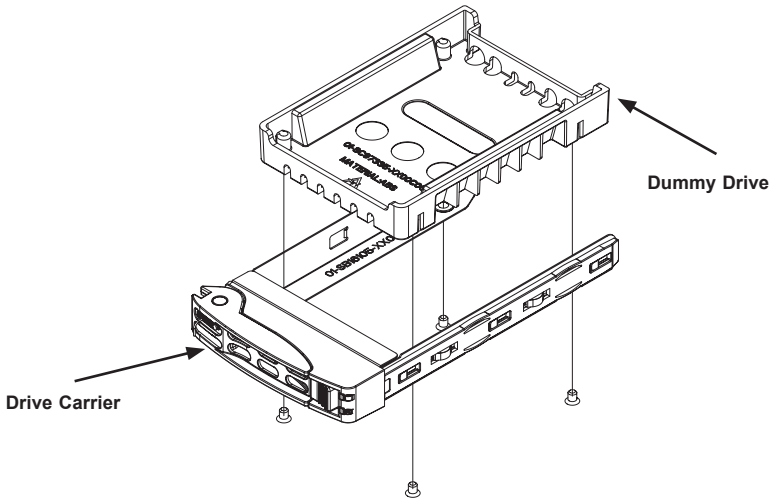
Figure 6-19. Installing a Drive into the Carrier

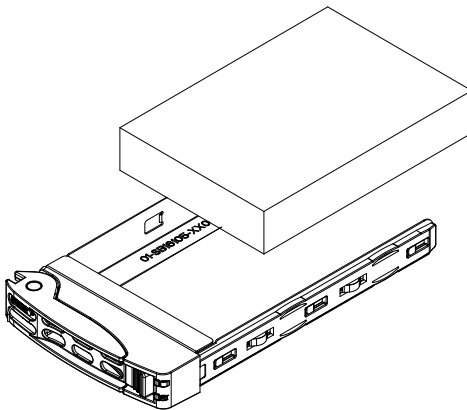

3. Use the open handle to replace the drive carrier into the chassis.
4. Gently close the drive carrier handle to secure the drive and carrier into the chassis drive bay.

6-10 Power Supply

The SC217 chassis includes a 1620 watt power supply. It automatically senses and operates at the proper voltage between 100v to 240v. An amber light on the power supply is illuminated when the system power is off. A green light indicates that the power supply is operating.

Power Supply Replacement

The SC217 chassis utilizes two redundant power supplies. In the unlikely event that the power supply unit needs to be replaced, one power supply can be removed, without powering down the system. Replacement units can be ordered directly from Supermicro (See the contact information in the Preface of this manual).

Changing the Power Supply

1. Push the release tab (on the back of the power supply) as illustrated.
2. Pull the power supply out using the handle provided.
3. Push the new power supply module into the power bay until it clicks into the locked position.

Figure 6-18. Changing the Power Supply

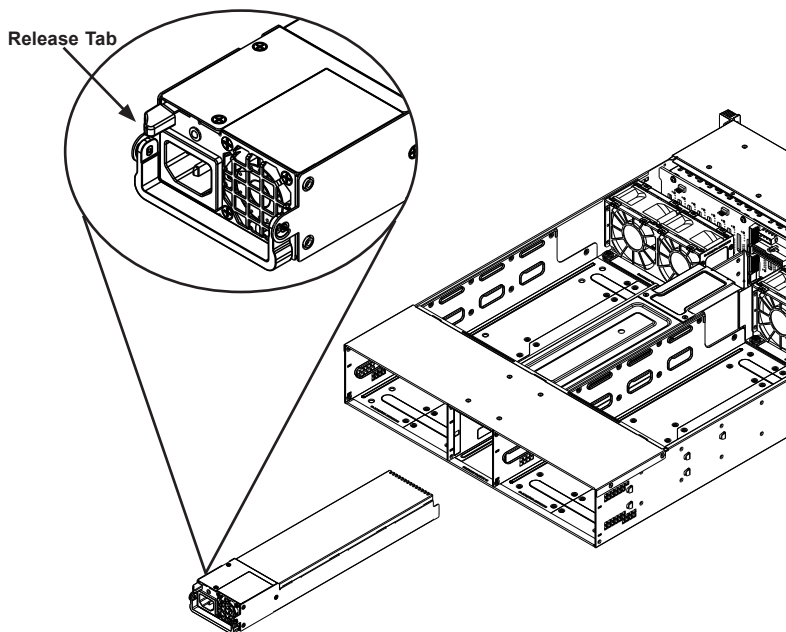

Notes

Chapter 7

BIOS

7-1 Introduction

This chapter describes the AMI BIOS Setup Utility for the H8DGT-HLIBQF/HLF-F. The 16 Mb AMI BIOS® is stored in a Flash EEPROM and can be easily updated. This chapter describes the basic navigation of the AMI BIOS Setup Utility setup screens.

Starting BIOS Setup Utility

To enter the AMI BIOS Setup Utility screens, press the <Delete> key while the system is booting up.

Note: In most cases, the <Delete> key is used to invoke the AMI BIOS setup screen. There are a few cases when other keys are used, such as <F1>, <F2>, etc.

Each main BIOS menu option is described in this manual. The Main BIOS setup menu screen has two main frames. The left frame displays all the options that can be configured. Grayed-out options cannot be configured. Options in blue can be configured by the user. The right frame displays the key legend. Above the key legend is an area reserved for a text message. When an option is selected in the left frame, it is highlighted in white. Often a text message will accompany it. (Note: the AMI BIOS has default text messages built in. Supermicro retains the option to include, omit, or change any of these text messages.)

The AMI BIOS Setup Utility uses a key-based navigation system called "hot keys". Most of the AMI BIOS setup utility "hot keys" can be used at any time during the setup navigation process. These keys include <F1>, <F10>, <Enter>, <ESC>, arrow keys, etc.

Note: Options printed in **Bold** are default settings.

How To Change the Configuration Data

The configuration data that determines the system parameters may be changed by entering the AMI BIOS Setup utility. This Setup utility can be accessed by pressing at the appropriate time during system boot.

Starting the Setup Utility

Normally, the only visible Power-On Self-Test (POST) routine is the memory test. As the memory is being tested, press the <Delete> key to enter the main menu of the AMI BIOS Setup Utility. From the main menu, you can access the other setup screens. An AMI BIOS identification string is displayed at the left bottom corner of the screen below the copyright message.

Warning! Do not upgrade the BIOS unless your system has a BIOS-related issue. Flashing the wrong BIOS can cause irreparable damage to the system. In no event shall Supermicro be liable for direct, indirect, special, incidental, or consequential damages arising from a BIOS update. If you have to update the BIOS, do not shut down or reset the system while the BIOS is updating. This is to avoid possible boot failure.

7-2 Main Setup

When you first enter the AMI BIOS Setup Utility, you will enter the Main setup screen. You can always return to the Main setup screen by selecting the Main tab on the top of the screen. The Main BIOS Setup screen is shown below.

System Overview: The following BIOS information will be displayed:

System Time/System Date

Use this option to change the system time and date. Highlight System Time or System Date using the arrow keys. Enter new values through the keyboard and press <Enter>. Press the <Tab> key to move between fields. The date must be entered in Day MM/DD/YY format. The time is entered in HH:MM:SS format. (Note: The time is in the 24-hour format. For example, 5:30 P.M. appears as 17:30:00.)

Supermicro H8DGT-HF (or H8DGT-HIBQF)

BIOS Build Version: This item displays the BIOS revision used in your system.

BIOS Build Date: This item displays the date when this BIOS was completed.

AMI BIOS Core Version: This item displays the revision number of the AMI BIOS Core upon which your BIOS was built.

Processor

The AMI BIOS will automatically display the status of the processor used in your system:

- **CPU Type:** This item displays the type of CPU used in the motherboard.
- **Speed:** This item displays the speed of the CPU detected by the BIOS.
- **Physical Count:** This item displays the number of processors installed in your system as detected by the BIOS.

- **Logical Count:** This item displays the number of CPU Cores installed in your system as detected by the BIOS.
- **Micro_code Revision:** This item displays the revision number of the BIOS Micro_code used in your system.

System Memory

This displays the size of memory available in the system:

- **Size:** This item displays the memory size detected by the BIOS.

Use this option to change the system time and date. Highlight System Time or System Date using the arrow keys. Enter new values through the keyboard. Press the <Tab> key or the arrow keys to move between fields. The date must be entered in Day MM/DD/YY format. The time is entered in HH:MM:SS format. (Note: The time is in the 24-hour format. For example, 5:30 P.M. appears as 17:30:00.)

AMIBIOS

Version

Build Date

Processor

The AMI BIOS will automatically display the status of processor as shown below:

Type of Processor

Speed

Physical Count

Logical Count

System Memory

This displays the size of memory available in the system:

Populated Size

Available Size

7-3 Advanced Setup Configurations

► Boot Feature Configuration

Quick Boot

If Enabled, this option will skip certain tests during POST to reduce the time needed for the system to boot up. The options are **Enabled** and Disabled.

Quiet Boot

If Disabled, normal POST messages will be displayed on boot-up. If **Enabled**, this display the OEM logo instead of POST messages.

Add On ROM Display Mode

This option sets the display mode for Option ROM. The options are **Force BIOS** or **Keep Current**.

Bootup Num Lock

This option selects the power-on state for the NUM lock to either **On** or **Off**.

Wait for F1 if Error

This setting controls the system response when an error is detected during the boot sequence. When enabled, BIOS will stop the boot sequence when an error is detected, at which point you will need to press the F1 button to re-enter the BIOS setup menu. The options are **Enabled** and **Disabled**.

Hit 'DEL' Message Display

Use this option to **Enable** or **Disable** the "Press DEL to run setup" message in POST.

Watch Dog Function

This option allows the system to restart when it isn't active for more than 5-minutes. Options include **Enabled** and **Disabled**.

Power Button Function

Use this option to select the mode for the power button when it is turned off. Options include **4 Seconds Override** or **Instant Off**.

Restore on AC Power Loss

This option sets the action the system will take if there is an AC power loss to the system. Options include **Power Off**, **Power On** or **Last State**.

Interrupt 19 Capture

Select **Enabled** to allow ROMs to trap Interrupt 19. The options are **Enabled** and **Disabled**.

► Processor & Clock Options Configuration

CPU Configuration

This displays static information on the Module Version, AGESA Version, Physical Count and Logical Count for the system's processor(s) and clock.

CPU Information

This setting is used to select which physical CPU's information to display. Options include **Processor 0** or Processor 1. The information for the selected processor includes Processor number, Revision, Cache L1/L2/L3, Speed, NB CLK, Able to Change Frequency and uCode Patch Level.

Note: Zero is always the "Boot Strap Processor" or main CPU with all others being "Application Processors".

GART Error Reporting

This option should remain disabled for normal operation. The driver developer may enable this option for testing purposes. Options are Enabled or **Disabled**.

Microcode Update

This setting **Enables** or Disables microcode updating.

Secure Virtual Machine Mode

This setting is used to **Enable** or Disable SVM.

Power Now

This setting is used to **Enable** or Disable the AMD Power Now feature.

Power Cap

This option can decide the highest P-state in the OS. Options include **P-state 0** through P-state 4.

ACPI SRAT Table

This option **Enables** or Disables the building of the ACPI SRAT Table.

CPU Down Core

This option sets down core support for the CPU. Options include **Disabled**, 2 Cores through 10 Cores in even numbered increments.

C1E Support

This option **Enables** or Disables C1E support.

Clock Speed Spectrum

This option enables or **disables** spread spectrum modulation.

▶ **Advanced Chipset Control Configuration**

▶ **NorthBridge Configuration**

▶ **Memory Configuration**

Bank Interleaving

Select Auto to automatically enable a bank-interleaving memory scheme when this function is supported by the processor. The options are **Auto** and Disabled.

Node Interleaving

This option enables node memory interleaving. Options include Auto or **Disabled**.

Channel Interleaving

This option enables channel memory interleaving. Options include **Auto** or Disabled.

CS Sparing

This setting will reserve a spare memory rank in each node when enabled. Options are Enabled and **Disabled**.

Bank Swizzle Mode

This setting **Enables** or Disables the bank swizzle mode.

▶ **ECC Configuration**

ECC Mode

This submenu sets the level of ECC protection. Options include Disabled, **Basic**, Good, Super, Max and User. Selecting User activates the other options for user setting.

Note: The "Super" ECC mode dynamically sets the DRAM scrub rate so all of memory is scrubbed in 8-hours.

DRAM ECC Enable

This setting allows hardware to report and correct memory errors automatically, maintaining system integrity. Options are **Enabled** or **Disabled**.

► DRAM Timing Configuration

DRAM Timing Config

This setting specifies the DRAM timing configuration. Options are **Auto** and **Manual**.

Memory Timing Parameters

This selects the which node's timing parameters to display. Options include **CPU Node 0**, CPU Node 1, CPU Node 2 or CPU Node 3.

IOMMU

This setting is used to enable or disable or set the GART size in systems without AGP. Options include **Enabled** and **Disabled**.

OHCI/EHCI HC Device Functions

These settings allow you to either **Enable** or **Disable** functions for OHCI or EHCI bus devices.

USB 2.0 Controller Mode

Use this setting to configure the USB 2.0 Controller in either Hi-Speed (480 Mps) or Full Speed (12 Mps) mode. Options include **Enabled** (Hi-Speed Mode) or **Disabled** (Full Speed Mode).

Legacy USB Support

Select "Enabled" to enable the support for USB Legacy. Disable Legacy support if there are no USB devices installed in the system. "Auto" disabled Legacy support if no USB devices are connected. The options are **Disabled**, **Enabled** and **Auto**.

► IDE Configuration

OnChip SATA Channel

This setting allows you to **Enable** or **Disable** the OnChip SATA channel.

OnChip SATA Type

Use this setting to set the OnChip SATA type. Options include Native IDE, RAID, **AMD_AHCI** and Legacy IDE.

RAID Codebase

This submenu appears when you choose "RAID" from the "OnChip SATA Type" setting above. This setting allows you to select the codebase for your RAID setup. Options are either Adaptec or **DotHill**.

SATA IDE Combined Mode

This setting allows you to **Enable** or Disable the SATA IDE combined mode.

PATA Channel Configuration

This allows you to set PATA channel configuration. Options include **SATA as Primary** or SATA as secondary.

► Primary/Secondary/Third/Fourth IDE Master/Slave

LBA/Large Mode

LBA (Logical Block Addressing) is a method of addressing data on a disk drive. The options are Disabled and **Auto**.

Block (Multi-Sector Transfer)

Block mode boosts IDE drive performance by increasing the amount of data transferred. Only 512 bytes of data can be transferred per interrupt if block mode is not used. Block mode allows transfers of up to 64 KB per interrupt.

Select "Disabled" to allow the data to be transferred from and to the device one sector at a time. Select "Auto" to allow the data transfer from and to the device occur multiple sectors at a time if the device supports it. The options are **Auto** and Disabled.

PIO Mode

PIO (Programmable I/O) mode programs timing cycles between the IDE drive and the programmable IDE controller. As the PIO mode increases, the cycle time decreases.

The options are **Auto**, 0, 1, 2, 3, and 4. Select Auto to allow BIOS to auto detect the PIO mode. Use this value if the IDE disk drive support cannot be determined. Select 0 to allow BIOS to use PIO mode 0, which has a data transfer rate of 3.3 MBs. Select 1 to allow BIOS to use PIO mode 1, which has a data transfer rate of 5.2 MBs. Select 2 to allow BIOS to use PIO mode 2, which has a data transfer rate of 8.3 MBs. Select 3 to allow BIOS to use PIO

mode 3, which has a data transfer rate of 11.1 MBs. Select 4 to allow BIOS to use PIO mode 4, which has a data transfer rate of 16.6 MBs. This setting generally works with all hard disk drives manufactured after 1999. For other disk drives, such as IDE CD-ROM drives, check the specifications of the drive.

DMA Mode

Selects the DMA Mode. Options are **Auto**, SWDMA0, SWDMA1, SWDMA2, MWDMA0, MDWDMA1, MWDMA2, UDMA0, UDMA1, UDMA2, UDMA3, UDMA4 and UDMA5. (SWDMA=Single Word DMA, MWDMA=Multi Word DMA, UDMA=UltraDMA.)

S.M.A.R.T.

Self-Monitoring Analysis and Reporting Technology (SMART) can help predict impending drive failures. Select "Auto" to allow BIOS to auto detect hard disk drive support. Select "Disabled" to prevent AMI BIOS from using the S.M.A.R.T. Select "Enabled" to allow AMI BIOS to use the S.M.A.R.T. to support hard drive disk. The options are Disabled, Enabled, and **Auto**.

32-Bit Data Transfer

Select "Enabled" to activate the function of 32-Bit data transfer. Select "Disabled" to deactivate the function. The options are **Enabled** and Disabled.

IDE Detect Timeout (Sec)

Use the +/- keys to adjust and select the time out for detecting ATA/ATAPI devices. The default value is **35**.

► PCI/PnP Configuration

Clear NVRAM

Select Yes to clear NVRAM during boot-up. The options are Yes and **No**.

Plug & Play O/S

Select Yes to allow the OS to configure Plug & Play devices. (This is not required for system boot if your system has an OS that supports Plug & Play.) Select **No** to allow AMIBIOS to configure all devices in the system.

PCI Latency Timer

This option sets the latency of all PCI devices on the PCI bus. Select a value to set the PCI latency in PCI clock cycles. Options are 32, **64**, 96, 128, 160, 192, 224 and 248.

PCI IDE Busmaster

Use this setting to **Enable** or Disable BIOS enabled uses of PCI Busmastering for reading or writing to IDE drives.

Onboard InfiniBand Controller

This option **Enables** or Disables the onboard InfiniBand controller.

Onboard VGA Controller

This option **Enables** or Disables the onboard VGA controller.

Onboard LAN Controller

This option **Enables** or Disables the onboard LAN controller.

ROM Scan Ordering

This setting determines which kind of option ROM activates prior to another. Options include **Onboard First** and Addon First.

PCIe X16 Slot 1

These settings **Enable** or Disable the specified PCIe slot in your system.

Onboard LAN Option ROM Select

This setting allows you to select the onboard LAN option ROM for iSCSI or **PXE**.

Note: You must enable **ONLY** LAN1 when the iSCSI support option is specified.

Load Onboard LAN 1 Option ROM

This option allows you to **enable** or disable the onboard LAN 1 option ROM.

Load Onboard LAN 2 Option ROM

This option allows you to **enable** or disable the onboard LAN 2 option ROM.

Primary Video Controller

This option specifies the primary video controller for **Onboard VGA** or Other.

► SuperIO Device Configuration

Serial 1 Address

This option specifies the base I/O port address and Interrupt Request address of serial port 1. Select "Disabled" to prevent the serial port from accessing any system resources. When this option is set to *Disabled*, the serial port physically becomes unavailable. Select "3F8/IRQ4" to allow the serial port to use 3F8 as its

I/O port address and IRQ 4 for the interrupt address. Options include Disabled, **3F8/IRQ4**, 3E8/IRQ4 and 2E8/IRQ3

Serial 2 Address

This option specifies the base I/O port address and Interrupt Request address of serial port 2. Select "Disabled" to prevent the serial port from accessing any system resources. When this option is set to "Disabled", the serial port physically becomes unavailable. Select "2F8/IRQ3" to allow the serial port to use 2F8 as its I/O port address and IRQ 3 for the interrupt address. Options include Disabled, **2F8/IRQ3**, 3E8/IRQ4 and 2F8/IRQ3.

Serial Port 2 Attribute

This option allows you to set COM2 as a normal serial port or as virtual COM for SOL. Options are **SOL** or COM.

► Remote Access Configuration

Remote Access

Use this option to **Enable** or Disable Remote Access in your system. If enabled, the settings below will appear.

Serial Port Number

Use this setting to select the serial port for console redirection. Options include COM1, **COM2***. The displayed base address and IRQ for the serial port changes to reflect the selection you make.

Note: Make sure the selected port is enabled.

Serial Port Mode

Selects the serial port settings to use. Options are (**115200 8, n, 1**), (57600 8, n, 1), (38400 8, n, 1), (19200 8, n, 1) and (09600 8, n, 1).

Flow Control

Selects the flow control to be used for console redirection. Options are **None**, Hardware and Software.

Redirection After BIOS POST

Options are Disable (no redirection after BIOS POST), Boot Loader (redirection during POST and during boot loader) and **Always** (redirection always active). Note that some OS's may not work with this set to Always.

Terminal Type

Selects the type of the target terminal. Options are **ANSI**, VT100 and VT-UTF8.

VT-UTF8 Combo Key Support

Allows you to **Enable** or Disable VT-UTF8 combination key support for ANSI/VT100 terminals.

Sredir Memory Display Delay

Use this setting to set the delay in seconds to display memory information. Options are **No Delay**, 1 sec, 2 secs and 4 secs.

► Hardware Health Configuration

CPU Overheat Alarm

This setting allows you to specify the type of alarm for CPU overheating. Options include The Early Alarm and **The Default Alarm**.

Fan Speed Control Modes

This feature allows the user to determine how the system will control the speed of the onboard fans. The options are Full Speed/FS (Max Cooling), Performance/PF (Better Cooling), **Balanced/BL** (Balance between performance and energy saving), Energy Saving/ES (Lower Power and Noise).

Other items in the submenu are systems monitor displays for the following information:

CPU 1 Temperature, CPU 2 Temperature, NB Temperature, VRD1 Temperature, VRD2 Temperature, System Temperature, Air Temperature, Fan 1 Reading, Fan 2 Reading, CPU1 Vcore, CPU2 Vcore, CPU1 Mem VTT, CPU2 Mem VTT, CPU1 Mem, CPU2 Mem, 1.1V, 1.8V, 5V +12V, 3.3 Vcc, 3.3 VSB, VBAT and HT Voltage.

► ACPI Configuration

ACPI Aware O/S

This setting Enables or Disables ACPI support for the system's operating system. Options include **Yes** (enabled) or No (disabled).

ACPI APIC Support

Determines whether to include the ACPI APIC table pointer in the RSDT pointer list. The available options are **Enabled** and Disabled.

Headless Mode

Use this setting to Enable or **Disable** headless operation mode through ACPI.

ACPI Version Features

Use this setting to determine which ACPI version to use. Options are ACPI v1.0, **ACPI v2.0** and ACPI v3.0.

▶ IPMI Configuration

This menu shows static information about the IPMI firmware revision and status of the BMC, as well as options for IPMI configuration.

▶ View BMC System Event Log

Pressing the Enter key will open the following settings. Use the "+" and "-" keys to navigate through the system event log.

Clear BMC System Event Log

Selecting this and pressing the Enter key will clear the BMC system event log.

▶ Set LAN Configuration

Use the "+" and "-" keys to choose the desired channel number. This displays Channel Number and Channel Number Status information.

This menu contains options for inputting settings for the SET LAN Configuration Command. See IPMI 1.5 Specification, table 11.1 for details. Use the "+" and "-" keys to choose the desired channel number.

Note: Each question in this group may take a considerable amount of time.

IP Address Source

Select the source of this machine's IP address. If Static is selected, you will need to know and enter manually the IP address of this machine below. If DHCP is selected, the BIOS will search for a DHCP (Dynamic Host Configuration Protocol) server in the network it is attached to, and request the next available IP address. The options are **DHCP** and Static.

The following items are assigned IP addresses automatically if DHCP is selected under IP Address Source above:

IP Address

This submenu sets the IP address source as either Static or DHCP. Selecting Static allows you to manually set the IP Address, Subnet Mask and Gateway Address.

In the field provided here enter the IP address in the decimal form of xxx.xxx.xxx.xxx with xxx having a value of less than 256 and in decimal form only. The IP address and current IP address in the BMC are shown.

Subnet Mask

In the field provided here enter the Subnet address in the decimal form of xxx.xxx.xxx.xxx with xxx having a value of less than 256 and in decimal form only. The current subnet address in the BMC is shown.

Gateway Address

In the field provided here enter the Gateway address in the decimal form of xxx.xxx.xxx.xxx with xxx having a value of less than 256 and in decimal form only. The current Gateway address in the BMC is shown.

MAC Address

In the field provided here enter the MAC address in the hex form of xx.xx.xx.xx.xx.xx with xx in hex form only. The current MAC address in the BMC is shown.

BMC Watch Dog Timer Action

This setting is used to set the Watch Dog function, which allows the BMC to reset or powerdown the system if the OS crashes or hangs. Options include **Disabled**, Reset System, Power Down and Power Cycle.

► Event Log Configuration

View Event Log

Pressing the Enter key will open the event log. Use the "↑" and "↓" keys to navigate through the system event log.

Mark All Events as Read

Selecting this and pressing the Enter key marks all events as read in the event log.

Clear Event Log

Selecting this and pressing the Enter key clears the system event log.

SR56x0 (RD890S) PCIE Error Log

This setting allows you set an error log ofr PCIE errors. Options include Yes or **No**.

7-3 Security Menu

AMI BIOS provides a Supervisor and a User password. If you use both passwords, the Supervisor password must be set first.

Change Supervisor Password

Select this option and press <Enter> to access the sub menu, and then type in the password.

Change User Password

Select this option and press <Enter> to access the sub menu, and then type in the password.

Boot Sector Virus Protection

This option is near the bottom of the Security Setup screen. Select "Disabled" to deactivate the Boot Sector Virus Protection. Select "Enabled" to enable boot sector protection. When "Enabled", AMI BIOS displays a warning when any program (or virus) issues a Disk Format command or attempts to write to the boot sector of the hard disk drive. The options are Enabled and **Disabled**.

7-4 Boot Menu

The Boot Menu is accessible only when the "Load Onboard LAN Option ROM" setting (in the PCI/PnP Configuration menu) is enabled.

► Boot Device Priority

This feature allows you to prioritize the boot sequence from the list of available devices. A device that is in parenthesis has been disabled in the corresponding type menu.

► Hard Disk Drives

This feature allows you to specify the boot sequence from the list of available hard disk drives. A device that is in parenthesis has been disabled in the corresponding type menu.

Retry Boot Devices

This option allows you to retry boot devices. Options include Enabled and **Disabled**.

7-5 Exit Menu

Select the Exit tab from AMI BIOS Setup Utility screen to enter the Exit BIOS Setup screen.

Save Changes and Exit

When you have completed the system configuration changes, select this option to leave BIOS Setup and reboot the computer, so the new system configuration parameters can take effect. Select Save Changes and Exit from the Exit menu and press <Enter>.

Discard Changes and Exit

Select this option to quit BIOS Setup without making any permanent changes to the system configuration and reboot the computer. Select Discard Changes and Exit from the Exit menu and press <Enter>.

Discard Changes

Select this option and press <Enter> to discard all the changes and return to AMI BIOS Utility Program.

Load Optimal Defaults

To set this feature, select Load Optimal Defaults from the Exit menu and press <Enter>. Then Select "OK" to allow BIOS to automatically load the Optimal Defaults as the BIOS Settings. The Optimal settings are designed for maximum system performance, but may not work best for all computer applications.

Load Fail-Safe Defaults

To set this feature, select Load Fail-Safe Defaults from the Exit menu and press <Enter>. The Fail-Safe settings are designed for maximum system stability, but not maximum performance.

Appendix A

BIOS Error Beep Codes

During the POST (Power-On Self-Test) routines, which are performed each time the system is powered on, errors may occur.

Non-fatal errors are those which, in most cases, allow the system to continue the boot-up process. The error messages normally appear on the screen.

Fatal errors are those which will not allow the system to continue the boot-up procedure. If a fatal error occurs, you should consult with your system manufacturer for possible repairs.

These fatal errors are usually communicated through a series of audible beeps. The numbers on the fatal error list (on the following page) correspond to the number of beeps for the corresponding error. All errors listed, with the exception of Beep Code 8, are fatal errors.

A-1 AMIBIOS Error Beep Codes

Beep Code	Error Message	Description
1 beep	Refresh	Circuits have been reset (Ready to power up)
5 short, 1 long	Memory error	No memory detected in system
1 long, 8 short	Video error	Video adapter disabled or missing

Notes

Appendix B

System Specifications

Note: Unless noted specifications apply to a complete system (all serverboards).

Processors

Dual AMD Opteron 6000 series processors (AMD Socket G34 type)

Note: Both CPUs must be of the same type.

Note: Please refer to our web site for a complete listing of supported processors.

Note: Supports 6000 processors with Max ACP 80W (TDP 115W).

Chipset

AMD SR5690/SP5100 Chipset

BIOS

16 Mb AMI BIOS® SPI Flash EPROM (each serverboard)

Memory Capacity

The H8DGT-HLIBQF/HLF serverboard has eight (8) single/dual/tri/quad channel DIMM slots supporting up to 256 GB of registered ECC or 64 GB of Unbuffered ECC/non-ECC DDR3-1600/1333/1066 MHz speed 1 GB, 2 GB, 4 GB, 8 GB or 16 GB size SDRAM

Note: Interleaved memory - requires memory must be installed four modules at a time. See Section 5-6 for details.

SAS Controller

LSI 2108 controller for 6 Gb/s SAS drives HW RAID (RAID 0, 1, 10, 5, 50, and 6 support)

Drive Bays

The A+ 2122TG-H6RF/H6IBQRF server supports twenty-four (24) hot-swap drive bays to house up to twenty-four SATA/SAS drives, six for each node

Expansion Slots

Total of four PCI-Express x16 low-profile slots on serverboards (one for each serverboard with preinstalled riser card)

Serverboard

Four H8DGT-HLIBQF/HLF (Extended ATX form factor)

Dimensions: (LxW) 6.78" x 16.64" (172 x 423 mm)

Chassis

SC217HQ-R1620BP (2U rackmount)

Dimensions: (WxHxD) 17.25 x 3.47 x 28.5 in. (438 x 88 x 724 mm)

Weight

Gross (Bare Bone): 85 lbs. (38.6 kg.)

System Cooling

The A+ Server 2122TG-H6IBQRF/H6RF contains four (4) 8-cm PWM system cooling fans

System Input Requirements

AC Input Voltage: 100-240V AC auto-range

Rated Input Current: 15A - 5A

Rated Input Frequency: 50 to 60 Hz

Efficiency: 94+ (Platinum Level)

Power Supply

The A+ Server 2122TG-H6IBQRF/H6RF has a 1620W high-efficiency redundant power supply w/PMBus (Part# PWS-1K62P-1R)

AC Input: 1000W Output @ 100-120V, 12-10A, 50-60Hz
 1200W Output @ 120-140V, 12-10A, 50-60Hz
 1620W Output @ 180-240V, 10.5-8A, 50-60Hz

DC Output 1000W: +12V/84A; +5Vsb/4A
 1200W: +12V/100A; +5Vsb/4A
 1620W: +12V/150A; +5Vsb/4A

Operating Environment

Operating Temperature: 10° to 30° C (50° to 86° F)

Non-operating Temperature: -40° to 70° C (-40° to 158° F)

Operating Relative Humidity: 20% to 95% (non-condensing)

Non-operating Relative Humidity: 5 to 95% (non-condensing)

Regulatory Compliance

Electromagnetic Emissions: FCC Class A, EN 55022 Class A, EN 61000-3-2/-3-3, CISPR 22 Class A

Electromagnetic Immunity: EN 55024/CISPR 24, (EN 61000-4-2, EN 61000-4-3, EN 61000-4-4, EN 61000-4-5, EN 61000-4-6, EN 61000-4-8, EN 61000-4-11)

Safety: CSA/EN/IEC/UL 60950-1 Compliant, UL or CSA Listed (USA and Canada), CE Marking (Europe)

California Best Management Practices Regulations for Perchlorate Materials: This Perchlorate warning applies only to products containing CR (Manganese Dioxide) Lithium coin cells. "Perchlorate Material-special handling may apply. See www.dtsc.ca.gov/hazardouswaste/perchlorate" for further details.

(continued from front)

The products sold by Supermicro are not intended for and will not be used in life support systems, medical equipment, nuclear facilities or systems, aircraft, aircraft devices, aircraft/emergency communication devices or other critical systems whose failure to perform be reasonably expected to result in significant injury or loss of life or catastrophic property damage. Accordingly, Supermicro disclaims any and all liability, and should buyer use or sell such products for use in such ultra-hazardous applications, it does so entirely at its own risk. Furthermore, buyer agrees to fully indemnify, defend and hold Supermicro harmless for and against any and all claims, demands, actions, litigation, and proceedings of any kind arising out of or related to such ultra-hazardous use or sale.