

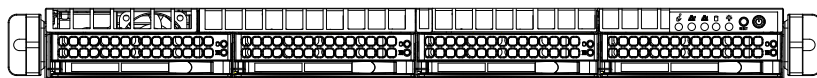

SUPERSERVER

6018R-TDTP  
6018R-TDTPR



USER'S MANUAL

1.0a

The information in this User's Manual has been carefully reviewed and is believed to be accurate. The vendor assumes no responsibility for any inaccuracies that may be contained in this document, makes no commitment to update or to keep current the information in this manual, or to notify any person or organization of the updates. **Please Note: For the most up-to-date version of this manual, please see our web site at [www.supermicro.com](http://www.supermicro.com).**

Super Micro Computer, Inc. ("Supermicro") reserves the right to make changes to the product described in this manual at any time and without notice. This product, including software and documentation, is the property of Supermicro and/or its licensors, and is supplied only under a license. Any use or reproduction of this product is not allowed, except as expressly permitted by the terms of said license.

IN NO EVENT WILL SUPERMICRO BE LIABLE FOR DIRECT, INDIRECT, SPECIAL, INCIDENTAL, SPECULATIVE OR CONSEQUENTIAL DAMAGES ARISING FROM THE USE OR INABILITY TO USE THIS PRODUCT OR DOCUMENTATION, EVEN IF ADVISED OF THE POSSIBILITY OF SUCH DAMAGES. IN PARTICULAR, SUPERMICRO SHALL NOT HAVE LIABILITY FOR ANY HARDWARE, SOFTWARE, OR DATA STORED OR USED WITH THE PRODUCT, INCLUDING THE COSTS OF REPAIRING, REPLACING, INTEGRATING, INSTALLING OR RECOVERING SUCH HARDWARE, SOFTWARE, OR DATA.

Any disputes arising between manufacturer and customer shall be governed by the laws of Santa Clara County in the State of California, USA. The State of California, County of Santa Clara shall be the exclusive venue for the resolution of any such disputes. Super Micro's total liability for all claims will not exceed the price paid for the hardware product.

FCC Statement: This equipment has been tested and found to comply with the limits for a Class A digital device pursuant to Part 15 of the FCC Rules. These limits are designed to provide reasonable protection against harmful interference when the equipment is operated in a commercial environment. This equipment generates, uses, and can radiate radio frequency energy and, if not installed and used in accordance with the manufacturer's instruction manual, may cause harmful interference with radio communications. Operation of this equipment in a residential area is likely to cause harmful interference, in which case you will be required to correct the interference at your own expense.

California Best Management Practices Regulations for Perchlorate Materials: This Perchlorate warning applies only to products containing CR (Manganese Dioxide) Lithium coin cells. "Perchlorate Material-special handling may apply. See [www.dtsc.ca.gov/hazardouswaste/perchlorate](http://www.dtsc.ca.gov/hazardouswaste/perchlorate)"

**WARNING: Handling of lead solder materials used in this product may expose you to lead, a chemical known to the State of California to cause birth defects and other reproductive harm.**

Manual Revision 1.0a  
Release Date: April 13, 2016

Unless you request and receive written permission from Super Micro Computer, Inc., you may not copy any part of this document.

Information in this document is subject to change without notice. Other products and companies referred to herein are trademarks or registered trademarks of their respective companies or mark holders.

Copyright © 2016 by Super Micro Computer, Inc.  
All rights reserved.  
**Printed in the United States of America**

---



---

## Preface

### About This Manual

This manual is written for professional system integrators and PC technicians. It provides information for the installation and use of the SuperServer 6018R-TDTP/TDTPR. Installation and maintenance should be performed by experienced technicians only.

The SuperServer 6018R-TDTP/TDTPR is a high-end server based on the SC-815TQ-600CB/SC815TQ-R500CB 1U rackmount chassis and the Super X10DRD-LTP serverboard.

### Manual Organization

#### Chapter 1: Introduction

The first chapter provides a checklist of the main components included with the server system and describes the main features of the X10DRD-LTP serverboard and the SC815TQ-600CB/SC815TQ-R500CB chassis.

#### Chapter 2: Server Installation

This chapter describes the steps necessary to install the SuperServer 6018R-TDTP/TDTPR into a rack and check out the server configuration prior to powering up the system. If your server was ordered without processor and memory components, this chapter will refer you to the appropriate sections of the manual for their installation.

#### Chapter 3: System Interface

Refer here for details on the system interface, which includes the functions and information provided by the control panel on the chassis as well as other LEDs located throughout the system.

#### Chapter 4: System Safety

You should thoroughly familiarize yourself with this chapter for a general overview of safety precautions that should be followed when installing and servicing the SuperServer 6018R-TDTP/TDTPR.

**Chapter 5: Advanced Serverboard Setup**

Chapter 5 provides detailed information on the X10DRD-LTP serverboard, including the locations and functions of connections, headers and jumpers. Refer to this chapter when adding or removing processors or main memory and when reconfiguring the serverboard.

**Chapter 6: Advanced Chassis Setup**

Refer to Chapter 6 for detailed information on the SC815TQ-600CB/SC815TQ-R500CB server chassis. You should follow the procedures given in this chapter when installing, removing or reconfiguring hard drives and when replacing system power supply modules and cooling fans.

**Chapter 7: BIOS**

The BIOS chapter includes an introduction to BIOS and provides detailed information on running the CMOS Setup Utility.

**Appendix A: BIOS Error Beep Codes****Appendix B: System Specifications****Notes**

# Table of Contents

## Chapter 1 Introduction

1-1	Overview .....	1-1
1-2	Serverboard Features .....	1-2
	Processors .....	1-2
	Memory .....	1-2
	SATA .....	1-2
	I/O Ports .....	1-2
1-3	Server Chassis Features .....	1-3
	System Power .....	1-3
	Hard Drive Subsystem .....	1-3
	Front Control Panel .....	1-3
	Cooling System .....	1-3
1-4	Contacting Supermicro .....	1-5

## Chapter 2 Server Installation

2-1	Overview .....	2-1
2-2	Unpacking the System .....	2-1
2-3	Preparing for Setup .....	2-1
	Choosing a Setup Location .....	2-1
2-4	Warnings and Precautions .....	2-2
	Rack Precautions .....	2-2
	Server Precautions .....	2-2
	Rack Mounting Considerations .....	2-3
	Ambient Operating Temperature .....	2-3
	Reduced Airflow .....	2-3
	Mechanical Loading .....	2-3
	Circuit Overloading .....	2-3
	Reliable Ground .....	2-3
2-5	Installing the System into a Rack .....	2-4
	Identifying the Sections of the Rack Rails .....	2-4
	Installing the Inner Rails .....	2-4
	Installing the Outer Rails .....	2-5
	Installing the Server into the Rack .....	2-6
	Installing the Server into a Telco Rack .....	2-7

## Chapter 3 System Interface

3-1	Overview .....	3-1
3-2	Control Panel Buttons .....	3-1
	Reset .....	3-1

	Power .....	3-1
3-3	Control Panel LEDs .....	3-2
	Information LED .....	3-2
	NIC1 .....	3-3
	NIC2 .....	3-3
	HDD .....	3-3
	Power .....	3-3
3-4	Drive Carrier LEDs .....	3-4
3-4	Hard Drive Carrier LEDs .....	3-4

## Chapter 4 Standardized Warning Statements for AC Systems

4-1	About Standardized Warning Statements .....	4-1
	Warning Definition .....	4-1
	Installation Instructions .....	4-4
	Circuit Breaker .....	4-5
	Power Disconnection Warning .....	4-6
	Equipment Installation .....	4-8
	Restricted Area .....	4-9
	Battery Handling .....	4-10
	Redundant Power Supplies .....	4-12
	Backplane Voltage .....	4-13
	Comply with Local and National Electrical Codes .....	4-14
	Product Disposal .....	4-15
	Hot Swap Fan Warning .....	4-16
	Power Cable and AC Adapter .....	4-18

## Chapter 5 Advanced Serverboard Setup

5-1	Handling the Serverboard .....	5-1
	Precautions .....	5-1
	Unpacking .....	5-1
5-2	Processor and Heatsink Installation .....	5-2
	Installing a Passive CPU Heatsink .....	5-5
	Removing the Heatsink .....	5-5
5-3	Connecting Cables .....	5-6
	Connecting Data Cables .....	5-6
	Connecting Power Cables .....	5-6
	Connecting the Control Panel .....	5-6
5-4	I/O Ports .....	5-7
5-5	Installing Memory .....	5-8
5-6	Adding PCI Cards .....	5-10
5-7	Serverboard Details .....	5-11

	X10DRD-LTP Quick Reference.....	5-12
5-8	Connector Definitions .....	5-13
5-9	Jumper Settings .....	5-19
5-10	Onboard Indicators.....	5-21
5-11	SATA Drive Ports.....	5-22
5-12	Installing Drivers.....	5-23
	SuperDoctor® 5 .....	5-24
5-13	Onboard Battery.....	5-25

**Chapter 6 Advanced Chassis Setup**

6-1	Static-Sensitive Devices.....	6-1
	Precautions .....	6-1
6-2	Control Panel .....	6-2
6-3	System Fans .....	6-3
	System Fan Failure.....	6-3
6-4	Drive Bay Installation/Removal .....	6-4
	Removing the Front Bezel .....	6-4
	Accessing the Drive Bays .....	6-5
	Hard Drive Installation.....	6-6
	DVD-ROM Drive Installation .....	6-8
6-5	Power Supply .....	6-9
	Power Supply Failure.....	6-9
	6018R-TDTP .....	6-9
	6018R-TDTPR.....	6-10
	Removing/Replacing the Power Supply.....	6-10

**Chapter 7 BIOS**

7-1	Introduction.....	7-1
	Starting BIOS Setup Utility.....	7-1
	How To Change the Configuration Data .....	7-1
	How to Start the Setup Utility .....	7-2
7-2	Main Setup.....	7-2
7-3	Advanced Setup Configurations.....	7-4
7-4	Event Logs .....	7-29
7-5	IPMI.....	7-31
7-6	Security Settings .....	7-34
7-7	Boot Settings.....	7-35
7-8	Save & Exit .....	7-38

**Appendix A BIOS Error Beep Codes**

**Appendix B System Specifications**

# Chapter 1

## Introduction

### 1-1 Overview

The SuperServer 6018R-TDTP/TDTPR is a high-end server comprised of two main subsystems: the SC815TQ-600CB/SC815TQ-R500CB 1U chassis and the X10DRD-LTP serverboard. Please refer to our website for information on operating systems that have been certified for use with the system ([www.supermicro.com](http://www.supermicro.com)).

In addition to the serverboard and chassis, various hardware components have been included with the 6018R-TDTP/TDTPR, as listed below:

- Five 4-cm counter-rotating fans (FAN-0086L4)
- Two passive CPU heatsinks (SNK-P0047PS)
- One RSC-RR1U-E8 riser card
- SATA Accessories
  - One SATA backplane (BPN-SAS-815TQ)
  - Four 3.5" hard drive carriers (MCP-220-00075-0B)
- One rail kit consisting of one set each of outer rails (MCP-290-00101-0N), inner rails (MCP-290-00105-0N) and inner rail extensions (MCP-290-00109-0N)

**Note:** For your system to work properly, please follow the links below to download all necessary drivers/utilities and the user's manual for your server.

- Supermicro product manuals: <http://www.supermicro.com/support/manuals/>
- Product drivers and utilities: <ftp://ftp.supermicro.com>
- Product safety info: [http://www.supermicro.com/about/policies/safety\\_information.cfm](http://www.supermicro.com/about/policies/safety_information.cfm)

---

## 1-2 Serverboard Features

At the heart of the SuperServer 6018R-TDTP/TDTPR lies the X10DRD-LTP, a dual processor serverboard based on the Intel PCH C612 chipset. Below are the main features of the X10DRD-LTP (see Figure 1-1 for a block diagram of the chipset).

### Processors

The X10DRD-LTP supports single or dual Intel® Xeon® E5-2600 v3/v4 series processors in R3-LGA2011 sockets. Please refer to the serverboard description pages on our website for a complete listing of supported processors.

### Memory

The X10DRD-LTP has eight DIMM sockets that can support up to 1 TB of LRDIMM (Load Reduced DIMM) or up to 512 GB of ECC RDIMM (Registered DIMM) DDR4-2400/2133/1866/1600 memory. Please refer to Chapter 5 for installing memory.

### SATA

Six SATA 3.0 ports are supported by the Intel PCH (I-SATA0-5). These ports are RAID 0, 1, 5 and 10 supported. The SATA drives are hot-swappable units.

**Note:** Documentation on RAID setup guidelines can be found on our website.

### I/O Ports

The rear I/O ports include one COM port, a VGA (monitor) port, four USB 2.0 ports and two 10 Gb Ethernet SFP+ ports. A dedicated IPMI LAN port is also included.

---

## 1-3 Server Chassis Features

The following is a general outline of the main features of the SC815TQ-600CB/SC815TQ-R500CB chassis.

### System Power

When configured as the SuperServer 6018R-TDTP/TDTPR, the SC815TQ-600CB includes a single high-efficiency 600W power supply and the SC815TQ-R500CB includes a redundant, 500W hot-plug, high-efficiency power supply, respectively.

### Hard Drive Subsystem

The SC815TQ-600CB/SC815TQ-R500CB chassis was designed to support four hot-swap SATA hard drives.

### Front Control Panel

The chassis' control panel provides you with system monitoring and control. LEDs indicate system power, HDD activity, network activity (two) and UID/overheat/fan fail/power fail. A main power button and system reset button is also included.

### Cooling System

The SC815TQ-600CB/SC815TQ-R500CB chassis has an innovative cooling design that features five 4-cm counter-rotating fans located in the middle section of the chassis. Fan speed may be controlled via IPMI. The power supply module also includes a cooling fan.

**Figure 1-1. Intel C612 Chipset:  
System Block Diagram**

Note: This is a general block diagram. Please see Chapter 5 for details.

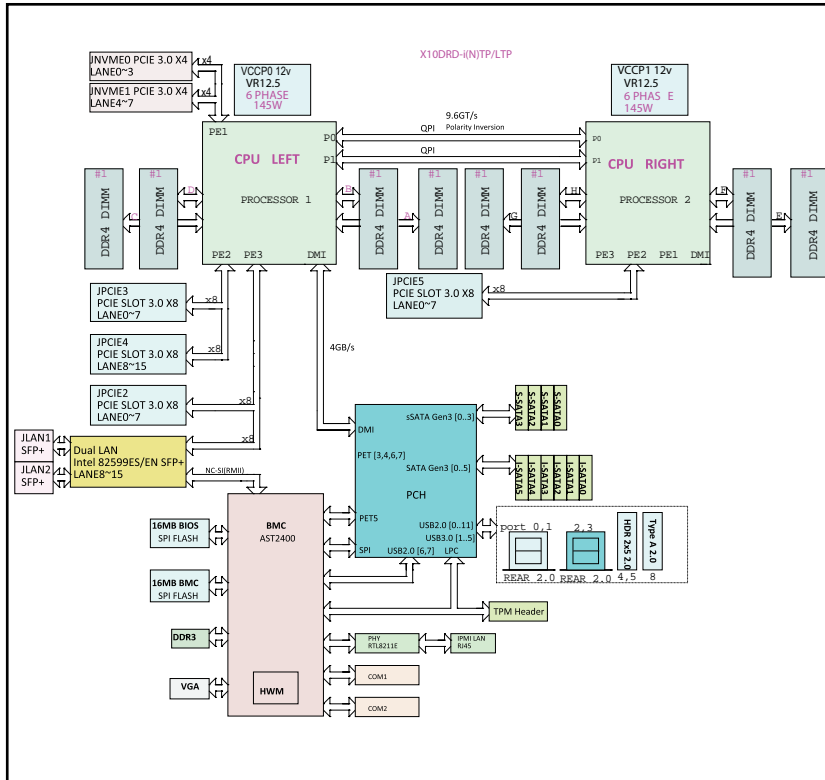

## 1-4 Contacting Supermicro

### Headquarters

Address: Super Micro Computer, Inc.  
980 Rock Ave.  
San Jose, CA 95131 U.S.A.  
Tel: +1 (408) 503-8000  
Fax: +1 (408) 503-8008  
Email: [marketing@supermicro.com](mailto:marketing@supermicro.com) (General Information)  
[support@supermicro.com](mailto:support@supermicro.com) (Technical Support)  
Website: [www.supermicro.com](http://www.supermicro.com)

### Europe

Address: Super Micro Computer B.V.  
Het Sterrenbeeld 28, 5215 ML  
's-Hertogenbosch, The Netherlands  
Tel: +31 (0) 73-6400390  
Fax: +31 (0) 73-6416525  
Email: [sales@supermicro.nl](mailto:sales@supermicro.nl) (General Information)  
[support@supermicro.nl](mailto:support@supermicro.nl) (Technical Support)  
[rma@supermicro.nl](mailto:rma@supermicro.nl) (Customer Support)  
Website: [www.supermicro.nl](http://www.supermicro.nl)

### Asia-Pacific

Address: Super Micro Computer, Inc.  
3F, No. 150, Jian 1st Rd.  
Zhonghe Dist., New Taipei City 235  
Taiwan (R.O.C)  
Tel: +886-(2) 8226-3990  
Fax: +886-(2) 8226-3992  
Email: [support@supermicro.com.tw](mailto:support@supermicro.com.tw)  
Website: [www.supermicro.com.tw](http://www.supermicro.com.tw)



## Notes

## Chapter 2

# Server Installation

### 2-1 Overview

This chapter provides a quick setup checklist to get your SuperServer 6018R-TDTP/TDTPR up and running. Following these steps in the order given should enable you to have the system operational within a minimum amount of time.

This quick setup assumes that your system has come to you with the processors and memory preinstalled. If your system is not already fully integrated with a motherboard, processors, system memory etc., please turn to the chapter or section noted in each step for details on installing specific components.

### 2-2 Unpacking the System

You should inspect the box the SuperServer 6018R-TDTP/TDTPR was shipped in and note if it was damaged in any way. If the server itself shows damage you should file a damage claim with the carrier who delivered it.

Decide on a suitable location for the rack unit that will hold the 6018R-TDTP/TDTPR. It should be situated in a clean, dust-free area that is well ventilated. Avoid areas where heat, electrical noise and electromagnetic fields are generated. You will also need it placed near a grounded power outlet. Be sure to read the Rack and Server Precautions in the next section.

### 2-3 Preparing for Setup

The box the SuperServer 6018R-TDTP/TDTPR was shipped in should include a rack mounting kit to install the system into the rack. Follow the steps in the order given to complete the installation process in a minimum amount of time. Please read this section in its entirety before you begin the installation procedure outlined in the sections that follow.

#### Choosing a Setup Location

- Leave enough clearance in front of the rack to enable you to open the front door completely (~25 inches) and approximately 30 inches of clearance in the back of the rack to allow for sufficient airflow and ease in servicing. This product is for installation only in a Restricted Access Location (dedicated equipment rooms, service closets and the like).

## 2-4 Warnings and Precautions

- This product is not suitable for use with visual display work place devices according to §2 of the the German Ordinance for Work with Visual Display Units.

### Rack Precautions

- Ensure that the leveling jacks on the bottom of the rack are fully extended to the floor with the full weight of the rack resting on them.
- In single rack installation, stabilizers should be attached to the rack. In multiple rack installations, the racks should be coupled together.
- Always make sure the rack is stable before extending a component from the rack.
- You should extend only one component at a time - extending two or more simultaneously may cause the rack to become unstable.

### Server Precautions

- Review the electrical and general safety precautions in Chapter 4.
- Determine the placement of each component in the rack *before* you install the rails.
- Install the heaviest server components on the bottom of the rack first, and then work up.
- Use a regulating uninterruptible power supply (UPS) to protect the server from power surges, voltage spikes and to keep your system operating in case of a power failure.
- Allow the hot plug SATA drives and power supply modules to cool before touching them.
- Always keep the rack's front door and all panels and components on the servers closed when not servicing to maintain proper cooling.

## Rack Mounting Considerations

### *Ambient Operating Temperature*

If installed in a closed or multi-unit rack assembly, the ambient operating temperature of the rack environment may be greater than the ambient temperature of the room. Therefore, consideration should be given to installing the equipment in an environment compatible with the manufacturer's maximum rated ambient temperature (T<sub>mra</sub>).

### *Reduced Airflow*

Equipment should be mounted into a rack so that the amount of airflow required for safe operation is not compromised.

### *Mechanical Loading*

Equipment should be mounted into a rack so that a hazardous condition does not arise due to uneven mechanical loading.

### *Circuit Overloading*

Consideration should be given to the connection of the equipment to the power supply circuitry and the effect that any possible overloading of circuits might have on overcurrent protection and power supply wiring. Appropriate consideration of equipment nameplate ratings should be used when addressing this concern.

### *Reliable Ground*

A reliable ground must be maintained at all times. To ensure this, the rack itself should be grounded. Particular attention should be given to power supply connections other than the direct connections to the branch circuit (i.e. the use of power strips, etc.).



**Warning!** To prevent bodily injury when mounting or servicing this unit in a rack, you must take special precautions to ensure that the system remains stable. The following guidelines are provided to ensure your safety:

- This unit should be mounted at the bottom of the rack if it is the only unit in the rack.
- When mounting this unit in a partially filled rack, load the rack from the bottom to the top with the heaviest component at the bottom of the rack.
- If the rack is provided with stabilizing devices, install the stabilizers before mounting or servicing the unit in the rack.

## 2-5 Installing the System into a Rack

This section provides information on installing the 6018R-TDTP/TDTPR into a rack unit with the rack rails provided. If the system has already been mounted into a rack, you can skip ahead to Sections 2-5 and 2-6.

There are a variety of rack units on the market, which may mean the assembly procedure will differ slightly. You should also refer to the installation instructions that came with the rack unit you are using.

### Identifying the Sections of the Rack Rails

You should have received two rack rail assemblies in the rack mounting kit. Each assembly consists of two sections: an inner fixed chassis rail that secures directly to the server chassis and an outer fixed rack rail that secures directly to the rack itself (see Figure 2-1). Two pairs of short brackets to be used on the front side of the outer rails are also included.

### Installing the Inner Rails

Both the left and right side inner rails have been pre-attached to the chassis. Proceed to the next step.

**Figure 2-1. Identifying the Sections of the Rack Rails (right side rail shown)**

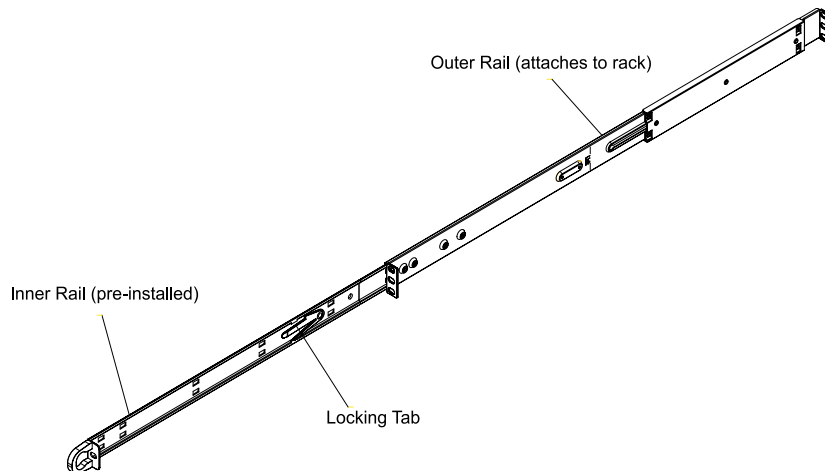

**Warning:** do not pick up the server with the front handles. They are designed to pull the system from a rack only.

### Installing the Outer Rails

Begin by measuring the distance from the front rail to the rear rail of the rack. Attach a short bracket to the front side of the right outer rail and a long bracket to the rear side of the right outer rail. Adjust both the short and long brackets to the proper distance so that the rail can fit snugly into the rack. Secure the short bracket to the front side of the outer rail with two screws and the long bracket to the rear side of the outer rail with three screws. Repeat these steps for the left outer rail.

**Locking Tabs:** Both chassis rails have a locking tab, which serves two functions. The first is to lock the server into place when installed and pushed fully into the rack, which is its normal position. Secondly, these tabs also lock the server in place when fully extended from the rack. This prevents the server from coming completely out of the rack when you pull it out for servicing.

**Figure 2-2. Installing the Rack Rails**

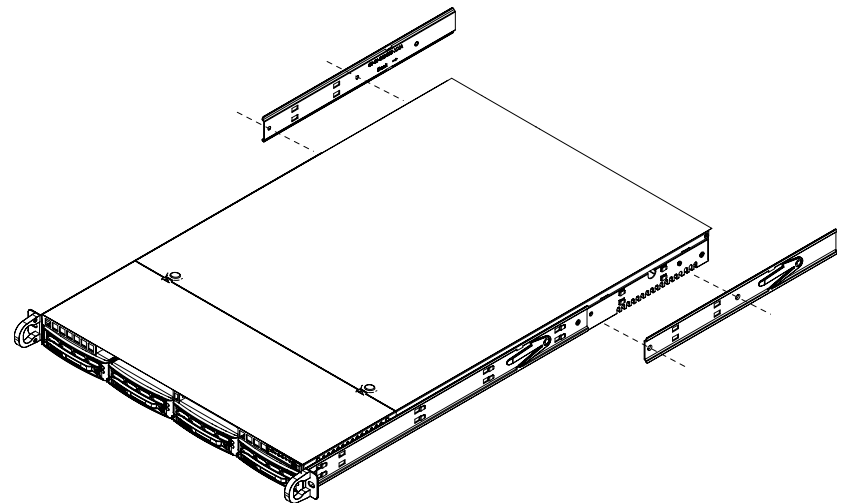

Slide rail mounted equipment is not to be used as a shelf or a work space.



Stability hazard. The rack stabilizing mechanism must be in place, or the rack must be bolted to the floor before you slide the unit out for servicing. Failure to stabilize the rack can cause the rack to tip over.

### Installing the Server into the Rack

You should now have rails attached to both the chassis and the rack unit. The next step is to install the server into the rack. Do this by lining up the rear of the chassis rails with the front of the rack rails. Slide the chassis rails into the rack rails, keeping the pressure even on both sides (you may have to depress the locking tabs when inserting). See Figure 2-3.

When the server has been pushed completely into the rack, you should hear the locking tabs "click".

Figure 2-3. Installing the Server into a Rack

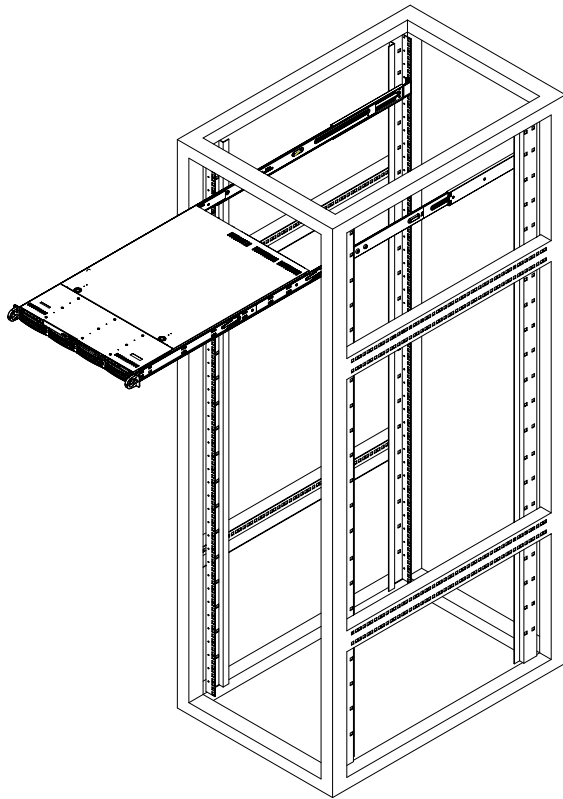

**Note:** The figure above is for illustration purposes only. Always install servers to the bottom of the rack first.

### Installing the Server into a Telco Rack

To install the 6018R-TDTP/TDTPR into a Telco type rack, use two L-shaped brackets on either side of the chassis (four total). First, determine how far from the server will extend out the front of the rack. Larger chassis should be positioned to balance the weight between front and back. If a bezel is included on your server, remove it. Then attach the two front brackets to each side of the chassis, then the two rear brackets positioned with just enough space to accommodate the width of the telco rack. Finish by sliding the chassis into the rack and tightening the brackets to the rack.

Figure 2-4. Installing the Server into a Telco Rack

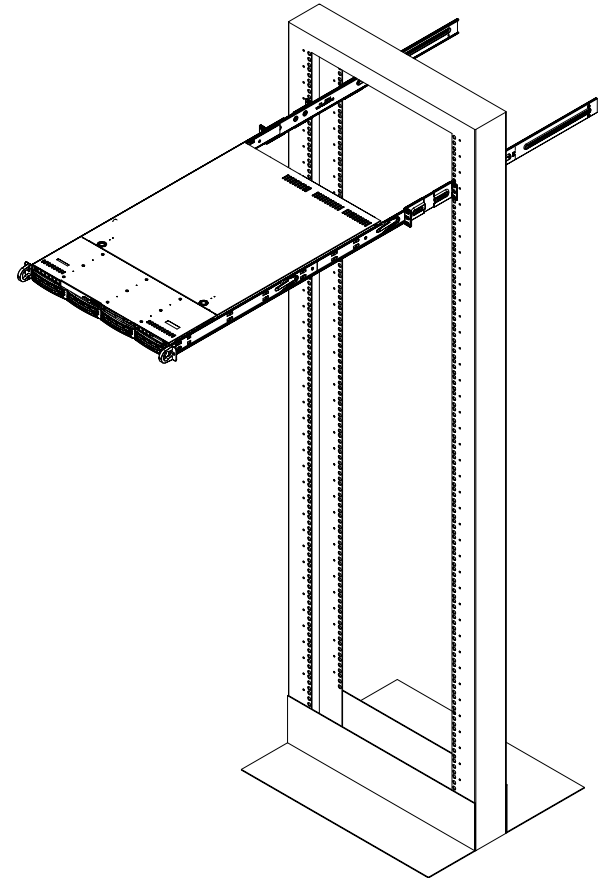

**Note:** The figure above is for illustration purposes only. Always install servers to the bottom of the rack first.

## Notes

## Chapter 3

# System Interface

### 3-1 Overview

There are several LEDs on the control panel as well as others on the hard drive carriers to keep you constantly informed of the overall status of the system as well as the activity and health of specific components. There are also two buttons on the chassis control panel and an on/off switch on the power supply. This chapter explains the meanings of all LED indicators and the appropriate response you may need to take.

### 3-2 Control Panel Buttons

There are two push-buttons located on the front of the chassis: a reset button and a power on/off button.

RESET



**Reset**

Use the reset button to reboot the system.



**Power**

The main power button is used to apply or remove power from the power supply to the server system. Turning off system power with this button removes the main power but keeps standby power supplied to the system.

### 3-3 Control Panel LEDs

The control panel located on the front of the SC815TQ chassis has five LEDs. These LEDs provide you with critical information related to different parts of the system. This section explains what each LED indicates when illuminated and any corrective action you may need to take.



#### Information LED

This LED will be solid blue when the UID function has been activated. When this LED flashes red, it indicates a fan failure. When red continuously it indicates an overheat condition, which may be caused by cables obstructing the airflow in the system or the ambient room temperature being too warm. Check the routing of the cables and make sure all fans are present and operating normally. You should also check to make sure that the chassis covers are installed. Finally, verify that the heatsinks are installed properly (see Chapter 5). This LED will remain flashing or on as long as the indicated condition exists.

**Figure 3-1. Information LED States**

Universal Information LED States	
State	Indication
Fast Blinking Red (1x/sec)	Fan Fail
Solid Red	CPU Overheat
Slow Blinking Red (1x/4 sec)	Power Fail
Solid Blue	Local UID Button Depressed
Blinking Blue	IPMI-Activated UID

**Note:** deactivating the UID LED must be performed in the same way it was activated. (If the UID LED was activated via IPMI, you can only turn the LED off via IPMI and not with the UID button.)



#### NIC1

Indicates network activity on LAN1 when flashing.



#### NIC2

Indicates network activity on LAN2 when flashing.



#### HDD

Indicates IDE channel activity. On the SuperServer 6018R-TDTP/TDTPR, this light indicates SATA and/or DVD-ROM drive activity when flashing.



#### Power

Indicates power is being supplied to the system's power supply units. This LED should normally be illuminated when the system is operating.



### 3-4 Hard Drive Carrier LEDs

Each hard drive carrier has two LEDs.

- **Green:** When illuminated, the green LED on the front of the drive carrier indicates drive activity. A connection to the SATA backplane enables this LED to blink on and off when that particular drive is being accessed.
- **Red:** The red LED indicates two states. When blinking, it indicates the drive is rebuilding. When solid, it indicates a drive failure. If a drive fails, you should be notified by your system management software. Please refer to Chapter 6 for instructions on replacing failed drives.

### 3-4 Drive Carrier LEDs

The chassis includes externally accessible SAS/SATA drives. Each drive carrier displays two status LEDs on the front of the carrier.

	LED Color	State	Status
<b>Activity LED</b>	Green	Solid On	SAS/SATA drive installed
	Green	Blinking	I/O activity
<b>Status LED</b>	Red	Solid On	Failed drive for SAS/SATA with RSTe support
	Red	Blinking at 1 Hz	Rebuild drive for SAS/SATA with RSTe support
	Red	Blinking with two blinks and one stop at 1 Hz	Hot spare for SAS/SATA with RSTe support
	Red	On for five seconds, then off	Power on for SAS/SATA with RSTe support
	Red	Blinking at 4 Hz	Identify drive for SAS/SATA with RSTe support

## Chapter 4

# Standardized Warning Statements for AC Systems

### 4-1 About Standardized Warning Statements

The following statements are industry standard warnings, provided to warn the user of situations which have the potential for bodily injury. Should you have questions or experience difficulty, contact Supermicro's Technical Support department for assistance. Only certified technicians should attempt to install or configure components.

Read this appendix in its entirety before installing or configuring components in the Supermicro chassis.

These warnings may also be found on our web site at [http://www.supermicro.com/about/policies/safety\\_information.cfm](http://www.supermicro.com/about/policies/safety_information.cfm).

#### Warning Definition



#### Warning!

This warning symbol means danger. You are in a situation that could cause bodily injury. Before you work on any equipment, be aware of the hazards involved with electrical circuitry and be familiar with standard practices for preventing accidents.

#### 警告の定義

この警告サインは危険を意味します。

人身事故につながる可能性がありますので、いずれの機器でも動作させる前に、電気回路に含まれる危険性に注意して、標準的な事故防止策に精通して下さい。

此警告符号代表危險。

您正處於可能受到嚴重傷害的工作環境中。在您使用設備開始工作之前，必須充分意識到觸電的危險，並熟练掌握防止事故發生的標準工作程序。請根據每項警告結尾的聲明號碼找到此設備的安全性警告說明的翻譯文本。

此警告符號代表危險。

您正處於可能身體可能會受損傷的工作環境中。在您使用任何設備之前，請注意觸電的危險，並且要熟悉預防事故發生的標準工作程序。請依照每一注意事項後的號碼找到相關的翻譯說明內容。

**Warnung****WICHTIGE SICHERHEITSHINWEISE**

Dieses Warnsymbol bedeutet Gefahr. Sie befinden sich in einer Situation, die zu Verletzungen führen kann. Machen Sie sich vor der Arbeit mit Geräten mit den Gefahren elektrischer Schaltungen und den üblichen Verfahren zur Vorbeugung vor Unfällen vertraut. Suchen Sie mit der am Ende jeder Warnung angegebenen Anweisungsnummer nach der jeweiligen Übersetzung in den übersetzten Sicherheitshinweisen, die zusammen mit diesem Gerät ausgeliefert wurden.

BEWAHREN SIE DIESE HINWEISE GUT AUF.

**INSTRUCCIONES IMPORTANTES DE SEGURIDAD**

Este símbolo de aviso indica peligro. Existe riesgo para su integridad física. Antes de manipular cualquier equipo, considere los riesgos de la corriente eléctrica y familiarícese con los procedimientos estándar de prevención de accidentes. Al final de cada advertencia encontrará el número que le ayudará a encontrar el texto traducido en el apartado de traducciones que acompaña a este dispositivo.

GUARDE ESTAS INSTRUCCIONES.

**IMPORTANTES INFORMATIONS DE SÉCURITÉ**

Ce symbole d'avertissement indique un danger. Vous vous trouvez dans une situation pouvant entraîner des blessures ou des dommages corporels. Avant de travailler sur un équipement, soyez conscient des dangers liés aux circuits électriques et familiarisez-vous avec les procédures couramment utilisées pour éviter les accidents. Pour prendre connaissance des traductions des avertissements figurant dans les consignes de sécurité traduites qui accompagnent cet appareil, référez-vous au numéro de l'instruction situé à la fin de chaque avertissement.

CONSERVEZ CES INFORMATIONS.

**תקנון הצהרות אזהרה**

הצהרות הבאות הן אזהרות על פי תקני התעשייה, על מנת להזהיר את המשתמש מפני חבלה פיזית אפשרית. במידה ויש שאלות או היתקלות בבעיה כלשהי, יש ליצור קשר עם מחלקת תמיכה טכנית של סופרמיקרו. טכנאים מוסמכים בלבד רשאים להתקין או להגדיר את הרכיבים.

יש לקרוא את הנספח במלואו לפני התקנת או הגדרת הרכיבים במאזי סופרמיקרו.

تحذير! هذا الرمز يعني خطر انك في حالة يمكن أن تتسبب في اصابة جسدية . قبل أن تعمل على أي معدات، كن على علم بالمخاطر الناجمة عن الدوائر الكهربائية  
وكن على دراية بالممارسات الوقائية لمنع وقوع أي حوادث  
استخدم رقم البيان المنصوص في نهاية كل تحذير للعثور ترجمتها

안전을 위한 주의사항

경고!

이 경고 기호는 위험이 있음을 알려 줍니다. 작업자의 신체에 부상을 야기 할 수 있는 상태에 있게 됩니다. 모든 장비에 대한 작업을 수행하기 전에 전기회로와 관련된 위험요소들을 확인하시고 사전에 사고를 방지할 수 있도록 표준 작업절차를 준수해 주시기 바랍니다.

해당 번역문을 찾기 위해 각 경고의 마지막 부분에 제공된 경고문 번호를 참조하십시오

**BELANGRIJKE VEILIGHEIDSINSTRUCTIES**

Dit waarschuwings symbool betekent gevaar. U verkeert in een situatie die lichamelijk letsel kan veroorzaken. Voordat u aan enige apparatuur gaat werken, dient u zich bewust te zijn van de bij een elektrische installatie betrokken risico's en dient u op de hoogte te zijn van de standaard procedures om ongelukken te voorkomen. Gebruik de nummers aan het eind van elke waarschuwing om deze te herleiden naar de desbetreffende locatie.

BEWAAR DEZE INSTRUCTIES

## Installation Instructions



### Warning!

Read the installation instructions before connecting the system to the power source.

設置手順書

システムを電源に接続する前に、設置手順書をお読み下さい。

警告

将此系统连接电源前，请先阅读安装说明。

警告

將系統與電源連接前，請先閱讀安裝說明。

Warnung

Vor dem Anschließen des Systems an die Stromquelle die Installationsanweisungen lesen.

¡Advertencia!

Lea las instrucciones de instalación antes de conectar el sistema a la red de alimentación.

Attention

Avant de brancher le système sur la source d'alimentation, consulter les directives d'installation.

יש לקרוא את הוראות התקנה לפני חיבור המערכת למקור מתח.

اقر إرشادات التركيب قبل توصيل النظام إلى مصدر للطاقة

시스템을 전원에 연결하기 전에 설치 안내를 읽어주시시오.

Waarschuwing

Raadpleeg de installatie-instructies voordat u het systeem op de voedingsbron aansluit.

## Circuit Breaker



### Warning!

This product relies on the building's installation for short-circuit (overcurrent) protection. Ensure that the protective device is rated not greater than: 250 V, 20 A.

サーキット・ブレーカー

この製品は、短絡(過電流)保護装置がある建物での設置を前提としています。

保護装置の定格が250 V、20 Aを超えないことを確認下さい。

警告

此产品的短路(过载电流)保护由建筑物的供电系统提供，确保短路保护设备的额定电流不大于250V,20A。

警告

此產品的短路(過載電流)保護由建築物的供電系統提供，確保短路保護設備的額定電流不大於250V,20A。

Warnung

Dieses Produkt ist darauf angewiesen, dass im Gebäude ein Kurzschluss- bzw. Überstromschutz installiert ist. Stellen Sie sicher, dass der Nennwert der Schutzvorrichtung nicht mehr als: 250 V, 20 A beträgt.

¡Advertencia!

Este equipo utiliza el sistema de protección contra cortocircuitos (o sobrecorrientes) del edificio. Asegúrese de que el dispositivo de protección no sea superior a: 250 V, 20 A.

Attention

Pour ce qui est de la protection contre les courts-circuits (surtension), ce produit dépend de l'installation électrique du local. Vérifiez que le courant nominal du dispositif de protection n'est pas supérieur à :250 V, 20 A.

מוצר זה מסתמך על הגנה המותקנת במבנים למניעת קצר חשמלי. יש לוודא כי המכשיר המגן מפני הקצר החשמלי הוא לא יותר מ-250 V, 20 A.

هذا المنتج يعتمد على معدات الحماية من الدوائر القصيرة التي تم تثبيتها في  
المبنى  
تأكد من أن تقييم الجهاز الوقائي ليس أكثر من: 20A, 250V

#### 경고!

이 제품은 전원의 단락(과전류)방지에 대해서 전적으로 건물의 관련 설비에 의존합니다. 보호장치의 정격이 반드시 250V(볼트), 20A(암페어)를 초과하지 않도록 해야 합니다.

#### Waarschuwing

Dit product is afhankelijk van de kortsluitbeveiliging (overspanning) van uw elektrische installatie. Controleer of het beveiligde apparaat niet groter gedimensioneerd is dan 220V, 20A.

### Power Disconnection Warning



#### Warning!

The system must be disconnected from all sources of power and the power cord removed from the power supply module(s) before accessing the chassis interior to install or remove system components.

#### 電源切斷の警告

システムコンポーネントの取り付けまたは取り外しのために、シャーシ内部にアクセスするには、

システムの電源はすべてのソースから切斷され、電源コードは電源モジュールから取り外す必要があります。

#### 警告

在你打开机箱并安装或移除内部器件前，必须将系统完全断电，并移除电源线。

#### 警告

在您打開機殼安裝或移除內部元件前，必須將系統完全斷電，並移除電源線。

#### Warnung

Das System muss von allen Quellen der Energie und vom Netzanschlusskabel getrennt sein, das von den Spg.Versorgungsteilmodulen entfernt wird, bevor es auf den Chassisinnenraum zurückgreift, um Systemsbestandteile anzubringen oder zu entfernen.

#### ¡Advertencia!

El sistema debe ser disconnected de todas las fuentes de energía y del cable eléctrico quitado de los módulos de fuente de alimentación antes de tener acceso el interior del chasis para instalar o para quitar componentes de sistema.

#### Attention

Le système doit être débranché de toutes les sources de puissance ainsi que de son cordon d'alimentation secteur avant d'accéder à l'intérieur du chasis pour installer ou enlever des composants de système.

### אזהרה מפני ניתוק חשמלי

#### אזהרה!

יש לנתק את המערכת מכל מקורות החשמל ויש להסיר את כבל החשמלי מהספק לפני גישה לחלק הפנימי של המארז לצורך התקנת או הסרת רכיבים.

يجب فصل النظام من جميع مصادر الطاقة وإزالة سلك الكهرباء من وحدة امداد الطاقة قبل الوصول إلى المناطق الداخلية للهيكल لتثبيت أو إزالة مكونات الجهاز

#### 경고!

시스템에 부품들을 장착하거나 제거하기 위해서는 새시 내부에 접근하기 전에 반드시 전원 공급장치로부터 연결되어있는 모든 전원과 전기코드를 분리해 주어야 합니다.

#### Waarschuwing

Voordat u toegang neemt tot het binnenwerk van de behuizing voor het installeren of verwijderen van systeem onderdelen, dient u alle spanningsbronnen en alle stroomkabels aangesloten op de voeding(en) van de behuizing te verwijderen

## Equipment Installation



### Warning!

Only trained and qualified personnel should be allowed to install, replace, or service this equipment.

#### 機器の設置

トレーニングを受け認定された人だけがこの装置の設置、交換、またはサービスを許可されています。

#### 警告

只有经过培训且具有资格的人员才能进行此设备的安装、更换和维修。

#### 警告

只有經過受訓且具資格人員才可安裝、更換與維修此設備。

#### Warnung

Das Installieren, Ersetzen oder Bedienen dieser Ausrüstung sollte nur geschultem, qualifiziertem Personal gestattet werden.

#### ¡Advertencia!

Solamente el personal calificado debe instalar, reemplazar o utilizar este equipo.

#### Attention

Il est vivement recommandé de confier l'installation, le remplacement et la maintenance de ces équipements à des personnels qualifiés et expérimentés.

#### אזהרה!

צוות מוסמך בלבד רשאי להתקין, להחליף את הציוד או לתת שירות עבור הציוד.

يجب أن يسمح فقط للموظفين المؤهلين والمدربين لتثبيت واستبدال أو خدمة هذا الجهاز

#### 경고!

훈련을 받고 공인된 기술자만이 이 장비의 설치, 교체 또는 서비스를 수행할 수 있습니다.

#### Waarschuwing

Deze apparatuur mag alleen worden geïnstalleerd, vervangen of hersteld door geschoold en gekwalificeerd personeel.

## Restricted Area



### Warning!

This unit is intended for installation in restricted access areas. A restricted access area can be accessed only through the use of a special tool, lock and key, or other means of security. (This warning does not apply to workstations).

#### アクセス制限区域

このユニットは、アクセス制限区域に設置されることを想定しています。

アクセス制限区域は、特別なツール、鍵と錠前、その他のセキュリティの手段を用いてのみ出入りが可能です。

#### 警告

此部件应安装在限制进出的场所，限制进出的场所指只能通过使用特殊工具、锁和钥匙或其它安全手段进出的场所。

#### 警告

此裝置僅限安裝於進出管制區域，進出管制區域係指僅能以特殊工具、鎖頭及鑰匙或其他安全方式才能進入的區域。

#### Warnung

Diese Einheit ist zur Installation in Bereichen mit beschränktem Zutritt vorgesehen. Der Zutritt zu derartigen Bereichen ist nur mit einem Spezialwerkzeug, Schloss und Schlüssel oder einer sonstigen Sicherheitsvorkehrung möglich.

#### ¡Advertencia!

Esta unidad ha sido diseñada para instalación en áreas de acceso restringido. Sólo puede obtenerse acceso a una de estas áreas mediante la utilización de una herramienta especial, cerradura con llave u otro medio de seguridad.

#### Attention

Cet appareil doit être installée dans des zones d'accès réservés. L'accès à une zone d'accès réservé n'est possible qu'en utilisant un outil spécial, un mécanisme de verrouillage et une clé, ou tout autre moyen de sécurité.

**אזור עם גישה מוגבלת****אזהרה!**

יש להתקין את היחידה באזורים שיש בהם הגבלת גישה. הגישה ניתנת בעזרת כלי אבטחה בלבד (מפתח, מנעול וכד').

تم تخصيص هذه الوحدة لتركيبها في مناطق محظورة .  
يمكن الوصول إلى منطقة محظورة فقط من خلال استخدام أداة خاصة،  
قفل ومفتاح أو أي وسيلة أخرى للأمان

**경고!**

이 장치는 접근이 제한된 구역에 설치하도록 되어 있습니다. 특수도구, 잠금 장치 및 키, 또는 기타 보안 수단을 통해서만 접근 제한 구역에 들어갈 수 있습니다.

**Waarschuwing**

Dit apparaat is bedoeld voor installatie in gebieden met een beperkte toegang. Toegang tot dergelijke gebieden kunnen alleen verkregen worden door gebruik te maken van speciaal gereedschap, slot en sleutel of andere veiligheidsmaatregelen.

**Battery Handling****Warning!**

There is the danger of explosion if the battery is replaced incorrectly. Replace the battery only with the same or equivalent type recommended by the manufacturer. Dispose of used batteries according to the manufacturer's instructions

**電池の取り扱い**

電池交換が正しく行われなかった場合、破裂の危険性があります。交換する電池はメーカーが推奨する型、または同等のものを使用下さい。使用済電池は製造元の指示に従って処分して下さい。

**警告**

電池更換不當會有爆炸危險。請只使用同類電池或製造商推薦的功能相當的電池更換原有電池。請按製造商的說明處理廢舊電池。

**警告**

電池更換不當會有爆炸危險。請使用製造商建議之相同或功能相當的電池更換原有電池。請按照製造商的說明指示處理廢棄舊電池。

**Warnung**

Bei Einsetzen einer falschen Batterie besteht Explosionsgefahr. Ersetzen Sie die Batterie nur durch den gleichen oder vom Hersteller empfohlenen Batterietyp. Entsorgen Sie die benutzten Batterien nach den Anweisungen des Herstellers.

**Attention**

Danger d'explosion si la pile n'est pas remplacée correctement. Ne la remplacer que par une pile de type semblable ou équivalent, recommandée par le fabricant. Jeter les piles usagées conformément aux instructions du fabricant.

**¡Advertencia!**

Existe peligro de explosión si la batería se reemplaza de manera incorrecta. Reemplazar la batería exclusivamente con el mismo tipo o el equivalente recomendado por el fabricante. Desechar las baterías gastadas según las instrucciones del fabricante.

**אזהרה!**

קיימת סכנת פיצוץ של הסוללה במידה והוחלפה בדרך לא תקינה. יש להחליף את הסוללה בסוג התואם מחברת יצרן מומלצת.

סילוק הסוללות המשומשות יש לבצע לפי הוראות היצרן.

هناك خطر من انفجار في حالة استبدال البطارية بطريقة غير صحيحة فعليك استبدال البطارية فقط بنفس النوع أو ما يعادلها كما أوصت به الشركة المصنعة تخلص من البطاريات المستعملة وفقا لتعليمات الشركة الصانعة

**경고!**

배터리가 올바르게 교체되지 않으면 폭발의 위험이 있습니다. 기존 배터리와 동일하거나 제조사에서 권장하는 동등한 종류의 배터리로만 교체해야 합니다. 제조사의 안내에 따라 사용된 배터리를 처리하여 주십시오.

**Waarschuwing**

Er is ontploffingsgevaar indien de batterij verkeerd vervangen wordt. Vervang de batterij slechts met hetzelfde of een equivalent type die door de fabrikant aanbevolen wordt. Gebruikte batterijen dienen overeenkomstig fabrieksvoorschriften afgevoerd te worden.

## Redundant Power Supplies



### Warning!

This unit might have more than one power supply connection. All connections must be removed to de-energize the unit.

### 冗長電源装置

このユニットは複数の電源装置が接続されている場合があります。  
ユニットの電源を切るためには、すべての接続を取り外さなければなりません。

### 警告

此部件连接的电源可能不止一个，必须将所有电源断开才能停止给该部件供电。

### 警告

此裝置連接的電源可能不只一個，必須切斷所有電源才能停止對該裝置的供電。

### Warnung

Dieses Gerät kann mehr als eine Stromzufuhr haben. Um sicherzustellen, dass der Einheit kein Strom zugeführt wird, müssen alle Verbindungen entfernt werden.

### ¡Advertencia!

Puede que esta unidad tenga más de una conexión para fuentes de alimentación. Para cortar por completo el suministro de energía, deben desconectarse todas las conexiones.

### Attention

Cette unité peut avoir plus d'une connexion d'alimentation. Pour supprimer toute tension et tout courant électrique de l'unité, toutes les connexions d'alimentation doivent être débranchées.

## אם קיים יותר מספק אחד

### אזהרה!

ליחידה יש יותר מחיבור אחד של ספק. יש להסיר את כל החיבורים על מנת לרוקן את היחידה.

قد يكون لهذا الجهاز عدة اتصالات بوحدات امداد الطاقة.  
يجب إزالة كافة الاتصالات لعزل الوحدة عن الكهرباء.

### 경고!

이 장치에는 한 개 이상의 전원 공급 단자가 연결되어 있을 수 있습니다. 이 장치에 전원을 차단하기 위해서는 모든 연결 단자를 제거해야만 합니다.

### Waarschuwing

Deze eenheid kan meer dan één stroomtoevoeraansluiting bevatten. Alle aansluitingen dienen verwijderd te worden om het apparaat stroomloos te maken.

## Backplane Voltage



### Warning!

Hazardous voltage or energy is present on the backplane when the system is operating. Use caution when servicing.

### バックプレーンの電圧

システムの稼働中は危険な電圧または電力が、バックプレーン上にかかっています。  
修理するにはご注意ください。

### 警告

当系统正在进行时，背板上有很危险的电压或能量，进行维修时务必小心。

### 警告

當系統正在進行時，背板上有危險的電壓或能量，進行維修時務必小心。

### Warnung

Wenn das System in Betrieb ist, treten auf der Rückwandplatine gefährliche Spannungen oder Energien auf. Vorsicht bei der Wartung.

### ¡Advertencia!

Quando el sistema está en funcionamiento, el voltaje del plano trasero es peligroso. Tenga cuidado cuando lo revise.



**Attention**

Lorsque le système est en fonctionnement, des tensions électriques circulent sur le fond de panier. Prendre des précautions lors de la maintenance.

**מתח בפנל האחורי**

אזהרה!

קיימת סכנת מתח בפנל האחורי בזמן תפעול המערכת. יש להיזהר במהלך העבודה.

هناك خطر من التيار الكهربائي أو الطاقة الموجودة على اللوحة عندما يكون النظام يعمل كن حذرا عند خدمة هذا الجهاز

경고!

시스템이 동작 중일 때 후면판 (Backplane)에는 위험한 전압이나 에너지가 발생 합니다. 서비스 작업 시 주의하십시오.

**Waarschuwing**

Een gevaarlijke spanning of energie is aanwezig op de backplane wanneer het systeem in gebruik is. Voorzichtigheid is geboden tijdens het onderhoud.

**Comply with Local and National Electrical Codes****Warning!**

Installation of the equipment must comply with local and national electrical codes.

地方および国の電気規格に準拠

機器の取り付けはその地方および国の電気規格に準拠する必要があります。

警告

设备安装必须符合本地与本国电气法规。

警告

設備安裝必須符合本地與本國電氣法規。

Warnung

Die Installation der Geräte muss den Sicherheitsstandards entsprechen.

¡Advertencia!

La instalación del equipo debe cumplir con las normas de electricidad locales y nacionales. Attention

L'équipement doit être installé conformément aux normes électriques nationales et locales.

**תיאום חוקי החשמל הארצי**

אזהרה!

התקנת הציוד חייבת להיות תואמת לחוקי החשמל המקומיים והארציים.

تركيب المعدات الكهربائية يجب أن يمتثل للقوانين المحلية والوطنية المتعلقة بالكهرباء

경고!

현 지역 및 국가의 전기 규정에 따라 장비를 설치해야 합니다.

**Waarschuwing**

Bij installatie van de apparatuur moet worden voldaan aan de lokale en nationale elektriciteitsvoorschriften.

**Product Disposal****Warning!**

Ultimate disposal of this product should be handled according to all national laws and regulations.

製品の廃棄

この製品を廃棄処分する場合、国の関係する全ての法律・条例に従い処理する必要があります。

警告

本产品的废弃处理应根据所有国家的法律和规章进行。

警告

本產品的廢棄處理應根據所有國家的法律和規章進行。

**Warnung**

Die Entsorgung dieses Produkts sollte gemäß allen Bestimmungen und Gesetzen des Landes erfolgen.

**¡Advertencia!**

Al deshacerse por completo de este producto debe seguir todas las leyes y reglamentos nacionales.

**Attention**

La mise au rebut ou le recyclage de ce produit sont généralement soumis à des lois et/ou directives de respect de l'environnement. Renseignez-vous auprès de l'organisme compétent.

**סילוק המוצר****אזהרה!**

סילוק סופי של מוצר זה חייב להיות בהתאם להנחיות וחוקי המדינה.

عند التخلص النهائي من هذا المنتج ينبغي التعامل معه وفقا لجميع القوانين واللوائح الوطنية

**경고!**

이 제품은 해당 국가의 관련 법규 및 규정에 따라 폐기되어야 합니다.

**Waarschuwing**

De uiteindelijke verwijdering van dit product dient te geschieden in overeenstemming met alle nationale wetten en reglementen.

**Hot Swap Fan Warning****Warning!**

The fans might still be turning when you remove the fan assembly from the chassis. Keep fingers, screwdrivers, and other objects away from the openings in the fan assembly's housing.

**ファン・ホットスワップの警告**

シャーシから冷却ファン装置を取り外した際、ファンがまだ回転している可能性があります。ファンの開口部に、指、ドライバー、およびその他のものを近づけないで下さい。

**警告**

当您从机架移除风扇装置，风扇可能仍在转动。小心不要将手指、螺丝起子和其他物品太靠近风扇

**警告**

當您從機架移除風扇裝置，風扇可能仍在轉動。小心不要將手指、螺絲起子和其他物品太靠近風扇。

**Warnung**

Die Lüfter drehen sich u. U. noch, wenn die Lüfterbaugruppe aus dem Chassis genommen wird. Halten Sie Finger, Schraubendreher und andere Gegenstände von den Öffnungen des Lüftergehäuses entfernt.

**¡Advertencia!**

Los ventiladores podran dar vuelta cuando usted quite el montaje del ventilador del chasis. Mantenga los dedos, los destornilladores y todos los objetos lejos de las aberturas del ventilador

**Attention**

Il est possible que les ventilateurs soient toujours en rotation lorsque vous retirerez le bloc ventilateur du châssis. Prenez garde à ce que doigts, tournevis et autres objets soient éloignés du logement du bloc ventilateur.

**אזהרה!**

כאשר מסירים את חלקי המאוורר מהמארז, יתכן והמאווררים עדיין עובדים. יש להרחיק למרחק בטוח את האצבעות וכלי עבודה שונים מהפתחים בתוך המאוורר

من الممكن أن المراوح لا تزال تدور عند إزالة كتلة المروحة من الهيكل يجب إبقاء الأصابع ومفكات البراغي وغيرها من الأشياء بعيدا عن الفتحات في كتلة المروحة.

**경고!**

새시로부터 팬 조립품을 제거할 때 팬은 여전히 회전하고 있을 수 있습니다. 팬 조립품 외관의 열려있는 부분들로부터 손가락 및 스크류드라이버, 다른 물체들이 가까이 하지 않도록 배치해 주십시오.

## Waarschuwing

Het is mogelijk dat de ventilator nog draait tijdens het verwijderen van het ventilatorsamenstel uit het chassis. Houd uw vingers, schroevendraaiers en eventuele andere voorwerpen uit de buurt van de openingen in de ventilatorbehuizing.

## Power Cable and AC Adapter



### Warning!

When installing the product, use the provided or designated connection cables, power cables and AC adaptors. Using any other cables and adaptors could cause a malfunction or a fire. Electrical Appliance and Material Safety Law prohibits the use of UL or CSA -certified cables (that have UL/CSA shown on the code) for any other electrical devices than products designated by Supermicro only.

### 電源コードとACアダプター

製品を設置する場合、提供または指定された接続ケーブル、電源コードとACアダプターを使用下さい。他のケーブルやアダプタを使用すると故障や火災の原因になることがあります。電気用品安全法は、ULまたはCSA認定のケーブル(UL/CSEマークがコードに表記)を Supermicroが指定する製品以外に使用することを禁止しています。

### 警告

安装此产品时,请使用本身提供的或指定的连接线,电源线和电源适配器.使用其它线材或适配器可能会引起故障或火灾.除了Supermicro所指定的产品,电气用品和材料安全法律规定禁止使用未经UL或CSA认证的线材。(线材上会显示UL/CSA符号)。

### 警告

安裝此產品時,請使用本身提供的或指定的連接線,電源線和電源適配器.使用其它線材或適配器可能會引起故障或火災.除了Supermicro所指定的產品,電氣用品和材料安全法律規定禁止使用未經UL或CSA認證的線材。(線材上會顯示UL/CSA符號)。

### Warnung

Bei der Installation des Produkts, die zur Verfügung gestellten oder benannt Anschlusskabel, Stromkabel und Netzteile. Verwendung anderer Kabel und Adapter kann zu einer Fehlfunktion oder ein Brand entstehen. Elektrische Geräte und Material Safety Law verbietet die Verwendung von UL-oder CSA-zertifizierte Kabel, UL oder CSA auf der Code für alle anderen elektrischen Geräte als Produkte von Supermicro nur bezeichnet gezeit haben.

## ¡Advertencia!

Al instalar el producto, utilice los cables de conexión previstos o designados, los cables y adaptadores de CA. La utilización de otros cables y adaptadores podría ocasionar un mal funcionamiento o un incendio. Aparatos Eléctricos y la Ley de Seguridad del Material prohíbe el uso de UL o CSA cables certificados que tienen UL o CSA se muestra en el código de otros dispositivos eléctricos que los productos designados por Supermicro solamente.

### Attention

Lors de l'installation du produit, utilisez les bables de connection fournis ou désigné. L'utilisation d'autres cables et adaptateurs peut provoquer un dysfonctionnement ou un incendie. Appareils électroménagers et de loi sur la sécurité Matériel interdit l'utilisation de UL ou CSA câbles certifiés qui ont UL ou CSA indiqué sur le code pour tous les autres appareils électriques que les produits désignés par Supermicro seulement.

## חשמלים ומתאמי AC

### אזהרה!

כאשר מתקינים את המוצר, יש להשתמש בכבלים, ספקים ומתאמים AC אשר נועדו וסופקו לשם כך. שימוש בכל כבל או מתאם אחר יכול לגרום לתקלה או קצר חשמלי. על פי חוקי שימוש במכשירי חשמל וחוקי בטיחות, קיים איסור להשתמש בכבלים המוסמכים ב- UL או ב- CSA (כשאר מופיע עליהם קוד של UL/CSA) עבור כל מוצר חשמלי אחר שלא צוין על ידי סופרמיקרו בלבד.

عند تركيب الجهاز يجب استخدام كابلات التوصيل، والكابلات الكهربائية ومحوالات التيار المتردد

التي . أن استخدام أي كابلات ومحوالات أخرى يتسبب في حدوث عطل أو حريق. تم توفيرها لك مع المنتج

الأجهزة الكهربائية ومواد قانون السلامة يحظر استخدام الكابلات UL أو CSA معتمدة من قبل

لأي أجهزة كهربائية أخرى غير المنتجات المعينة من قبل Supermicro (التي تحمل علامة UL/CSA)

### 경고!

제품을 설치할 때에는 제공되거나 지정된 연결케이블과 전원케이블, AC어댑터를 사용해야 합니다. 그 밖의 다른 케이블들이나 어댑터들은 고장 또는 화재의 원인이 될 수 있습니다. 전기용품안전법 (Electrical Appliance and Material Safety Law)은 슈퍼마이크로에서 지정한 제품들 외에는 그 밖의 다른 전기 장치들을 위한 UL 또는 CSA에서 인증한 케이블(전선 위에 UL/CSA가 표시)들의 사용을 금지합니다.

### Waarschuwing

Bij het installeren van het product, gebruik de meegeleverde of aangewezen kabels, stroomkabels en adapters. Het gebruik van andere kabels en adapters kan leiden tot een storing of een brand. Elektrisch apparaat en veiligheidsinformatiebladen wet verbiedt het gebruik van UL of CSA gecertificeerde kabels die UL of CSA die op de code voor andere elektrische apparaten dan de producten die door Supermicro alleen.

## Chapter 5

### Advanced Serverboard Setup

This chapter covers the steps required to install processors and heatsinks to the X10DRD-LTP serverboard, connect the data and power cables and install add-on cards. All serverboard jumpers and connections are described and a layout and quick reference chart are included in this chapter. Remember to close the chassis completely when you have finished working on the serverboard to protect and cool the system sufficiently.

#### 5-1 Handling the Serverboard

Static electrical discharge can damage electronic components. To prevent damage to printed circuit boards, it is important to handle them very carefully (see Chapter 4). Also note that the size and weight of the serverboard can cause it to bend if handled improperly, which may result in damage. To prevent the serverboard from bending, keep one hand under the center of the board to support it when handling.

The following measures are generally sufficient to protect your equipment from static discharge.

##### Precautions

- Use a grounded wrist strap designed to prevent static discharge.
- Touch a grounded metal object before removing any board from its antistatic bag.
- Handle a board by its edges only; do not touch its components, peripheral chips, memory modules or gold contacts.
- When handling chips or modules, avoid touching their pins.
- Put the serverboard, add-on cards and peripherals back into their antistatic bags when not in use.

##### Unpacking

The serverboard is shipped in antistatic packaging to avoid static damage. When unpacking the board, make sure the person handling it is static protected.

## 5-2 Processor and Heatsink Installation

### Notes

- Always connect the power cord last and always remove it before adding, removing or changing any hardware components. Make sure that you install the processor into the CPU socket before you install the CPU heatsink.
- If you buy a CPU separately, make sure that you use an Intel-certified multi-directional heatsink only.
- Make sure to install the serverboard into the chassis before you install the CPU heatsinks.
- When receiving a serverboard without a processor pre-installed, make sure that the plastic CPU socket cap is in place and none of the socket pins are bent; otherwise, contact your retailer immediately.
- Refer to the Supermicro website for updates on CPU support.

### Installing a CPU

1. There are two levers on the LGA 2011 socket. First press and release the load lever labeled "Open 1st".

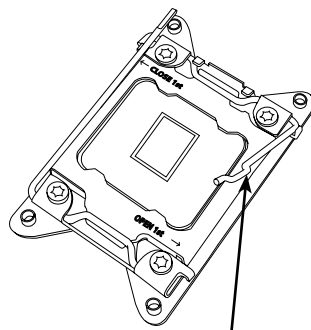

Release the lever labeled "Open 1st"

2. Press the second load lever labeled "Close 1st" to release the load plate from its locked position.

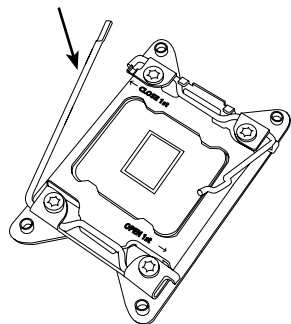

Release the lever labeled "Close 1st"

3. With the second lever fully retracted, gently push down on the "Open 1st" lever to loosen the load plate. Lift the load plate with your fingers to open it completely.

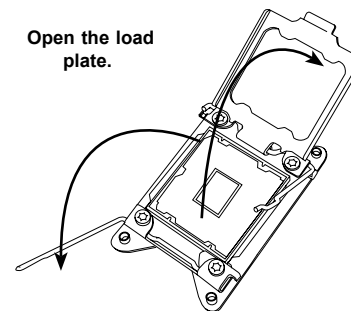

4. Pop the plastic cap marked "Warning" out of the load plate.
5. Holding the CPU carefully above the socket, orient the CPU so that all keys and edges will fit the socket.

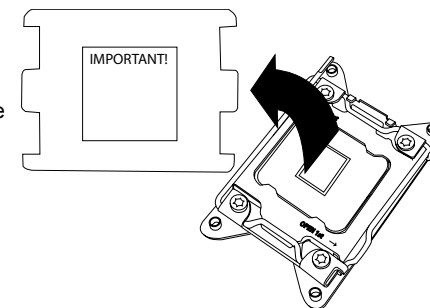

6. Carefully lower the CPU straight down into the socket. Do not move the CPU horizontally, and do not rub the pins of the socket. This may damage the CPU or the socket.

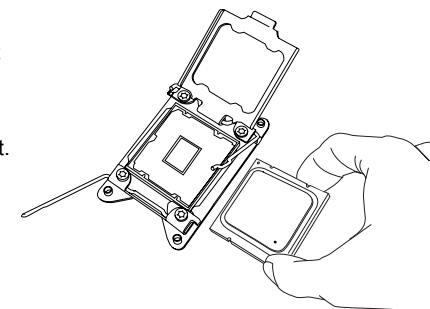

**Caution:** You can only install the CPU into the socket in one direction. Make sure that the CPU is properly inserted into the socket before closing the load plate. If it does not close properly, do not force it as it may damage your CPU. Instead, open the load plate again and double-check that the CPU is aligned properly.

7. With the "Close 1st" lever fully retracted, gently close the load plate.

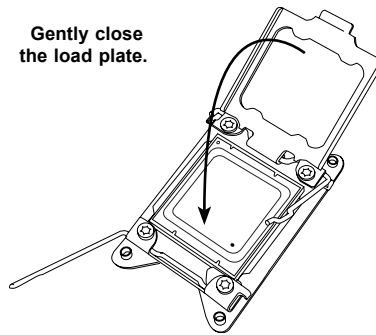

8. Make sure the locking mechanism on the "Close 1st" lever catches the lip of the load plate. Close and lock the "Close 1st" lever.

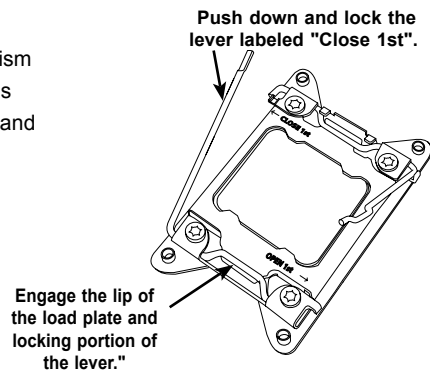

9. Close and lock the "Open 1st" lever.

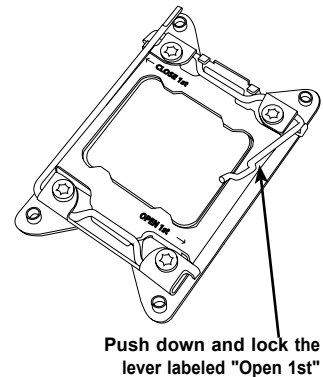

## Installing a Passive CPU Heatsink

1. Do not apply any thermal grease to the heatsink or the CPU die -- the required amount has already been applied.
2. Place the heatsink on top of the CPU so that the four mounting holes are aligned with those on the serverboard and the heatsink bracket underneath.
3. Screw in two diagonal screws (i.e., the #1 and the #2 screws) until just snug (do not over-tighten the screws to avoid possible damage to the CPU.)
4. Add the two remaining screws then fully tighten all four screws.

## Removing the Heatsink

**Warning:** We do not recommend removing the CPU or the heatsink. However, if you do need to remove it, please follow the instructions below to prevent damage to the CPU or other components.

1. Unscrew the heatsink screws from the serverboard in the sequence shown below.
2. Gently wriggle the heatsink to loosen it from the CPU (do not use excessive force). Once the heatsink is loose, remove it from the CPU.
3. Clean the surface of the CPU and the heatsink, removing the used thermal grease. Reapply the proper amount of thermal grease on the surface before re-installing.

Figure 5-1. Installing the Heatsink

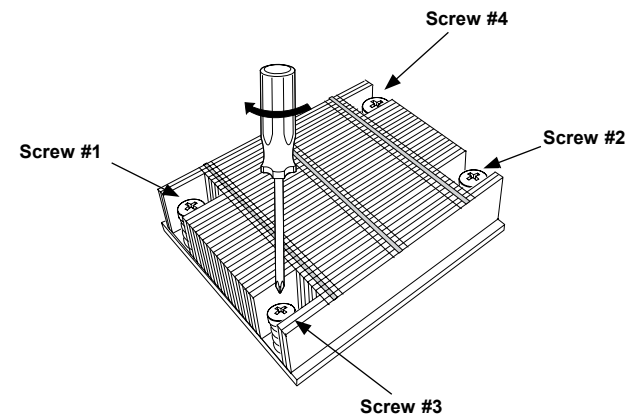

### 5-3 Connecting Cables

Now that the processors are installed, the next step is to connect the cables to the serverboard. These include the data (ribbon) cables for the peripherals and control panel and the power cables.

#### Connecting Data Cables

The cables used to transfer data from the peripheral devices have been carefully routed in preconfigured systems to prevent them from blocking the flow of cooling air that moves through the system from front to back.

If you need to disconnect any of these cables, you should take care to reroute them as they were originally after reconnecting them (be aware of the pin 1 locations). If you are configuring the system, keep the airflow in mind when routing the cables.

#### Connecting Power Cables

The X10DRD-LTP has a 24-pin primary power supply connector designated "JPWR1" for connection to the ATX power supply. Connect the appropriate connector from the power supply to JPW1 to supply power to the serverboard. See the Connector Definitions section in this chapter for power connector pin definitions.

In addition, your power supply must be connected to the 8-pin Processor Power connectors at JPWR2 and JPWR3.

#### Connecting the Control Panel

JF1 contains header pins for various front control panel connectors. See Figure 5-2 for the pin locations of the various front control panel buttons and LED indicators. Please note that even and odd numbered pins are on opposite sides of each header. All JF1 wires have been bundled into single keyed ribbon cable to simplify their connection. Connect one end of this cable to JF1 and the other end to the Control Panel printed circuit board, located just behind the system status LEDs in the chassis.

See the Connector Definitions section in this chapter for details and pin descriptions of JF1.

Figure 5-2. Front Control Panel Header Pins (JF1)

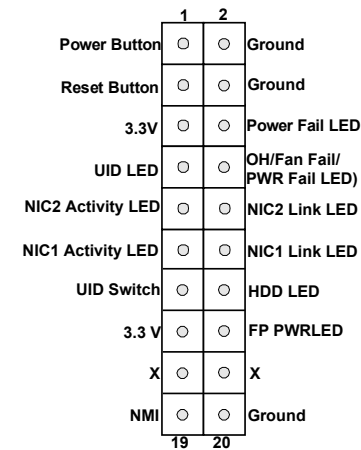

### 5-4 I/O Ports

See Figure 5-3 below for the descriptions of the various I/O ports.

Figure 5-3. Rear Panel I/O Ports

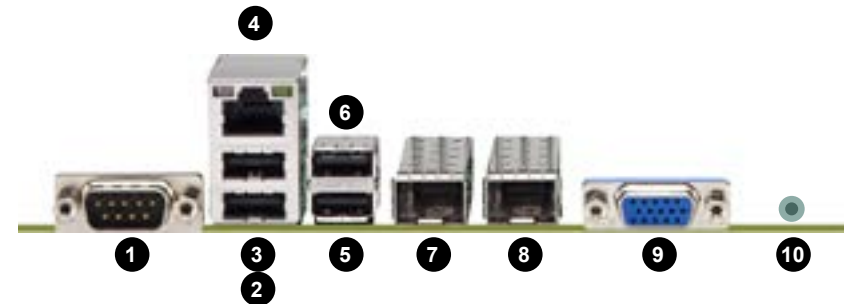

Backplane I/O Ports	
1. COM Port	6. USB 2.0 Port
2. USB 2.0 Port	7. 10 Gb SFP+ LAN Port 1
3. USB 2.0 Port	8. 10 Gb SFP+ LAN Port 2
4. Dedicated IPMI LAN Port	9. VGA Port
5. USB 2.0 Port	10. UID Button/LED



## 5-5 Installing Memory

Note: Check the Supermicro website for recommended memory modules.

### CAUTION

Exercise extreme care when installing or removing DIMM modules to prevent any possible damage.

#### Installing DIMMs

1. Insert the desired number of DIMMs into the memory slots, starting with slots DIMM1A. Pay attention to the notch along the bottom of the module to prevent inserting the DIMM module incorrectly. See Figure 5-4.
2. Gently press down on the DIMM module until it snaps into place in the slot. Repeat step 1 to install to DIMM1B if needed.

#### Memory Support

The X10DRD-LTP has eight DIMM sockets that can support up to 1 TB of LRDIMM (Load Reduced DIMM) or up to 512 GB of ECC RDIMM (Registered DIMM) DDR4-2400/2133/1866/1600 memory.

For the latest memory updates, please refer to our website. Please follow the tables below for correct installation.

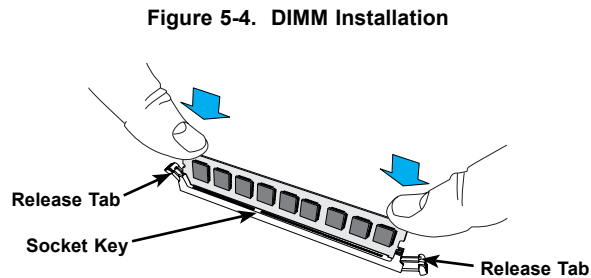

Figure 5-4. DIMM Installation

### Processor & Memory Module Population Configuration

For the memory to work properly, follow the tables below.

Processors and their Corresponding Memory Modules				
CPU#	Corresponding DIMM Modules			
CPU 1	P1-DIMMA1	P1-DIMMB1	P1-DIMMC1	P1-DIMMD1
CPU2	P2-DIMME1	P2-DIMMF1	P2-DIMMG1	P2-DIMMH1

Processor and Memory Module Population for Optimal Performance	
Number of CPUs+DIMMs	CPU and Memory Population Configuration Table
1 CPU & 2 DIMMs	CPU1 P1-DIMMA1/P1-DIMMB1
1 CPU & 4 DIMMs	CPU1 P1-DIMMA1/P1-DIMMB1, P1-DIMMC1/P1-DIMMD1
2 CPUs & 4 DIMMs	CPU1 + CPU2 P1-DIMMA1/P1-DIMMB1, P2-DIMME1/P2-DIMMF1
2 CPUs & 6 DIMMs	CPU1 + CPU2 P1-DIMMA1/P1-DIMMB1/P1-DIMMC1/P1-DIMMD1, P2-DIMME1/P2-DIMMF1
2 CPUs & 8 DIMMs	CPU1 + CPU2 P1-DIMMA1/P1-DIMMB1/P1-DIMMC1/P1-DIMMD1, P2-DIMME1/P2-DIMMF1/P2-DIMMG1/P2-DIMMH1

Populating RDIMM/LRDIMM DDR4 Memory Modules					
Type	Ranks Per DIMM and Data Width	DIMM Capacity (GB)		Speed (MT/s); Voltage (V); Slots per Channel (SPC) and DIMMs per Channel (DPC)	
				1 Slot per Channel	
		4 Gb   8 Gb		1 DPC	
				E5-2600 V3	E5-2600 V4
RDIMM	SRx4	8 GB	16 GB	2133	2400
RDIMM	SRx8	4 GB	8 GB	2133	2400
RDIMM	DRx8	8 GB	16 GB	2133	2400
RDIMM	DRx4	16 GB	32 GB	2133	2400
LRDIMM	QRx4	32 GB	64 GB	2133	2400
LRDIMM 3DS	8Rx4	64 GB	128 GB	2133	2400

## 5-6 Adding PCI Cards

### PCI Expansion Slots

One RSC-RR1U-E8 riser card is used to support a standard size expansion (add-on) card to the system.

### PCI Card Installation

Before installing a PCI add-on card, make sure it is supported by the riser card. Begin by releasing the locking tab that corresponds to the slot you wish to populate. Insert the expansion card into the riser card by pushing down with your thumbs evenly on both sides of the card.

### PCI Slot/Card Configurations

#### Riser Card

RSC-RR1U-E8 (pre-installed)

#### Expansion Card Supported

1x PCI-E 3.0 x8 card

## 5-7 Serverboard Details

Figure 5-5. SUPER X10DRD-LTP Layout

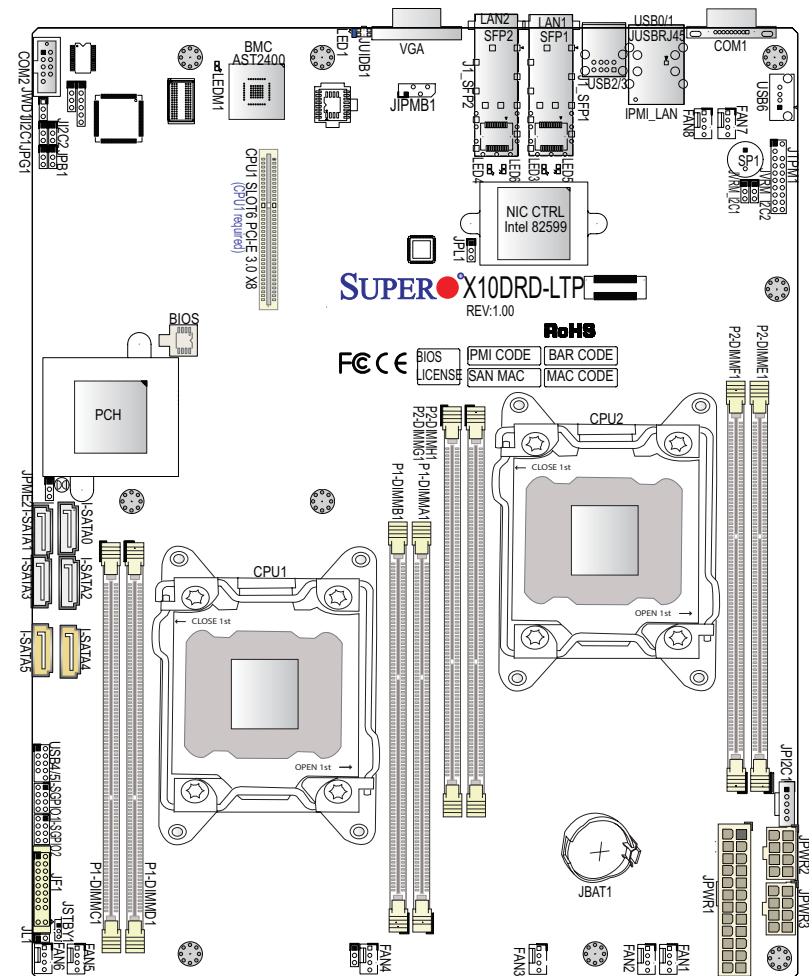

### Notes:

- "■" indicates the location of pin 1.
- Jumpers/LED indicators not indicated are used for testing purposes only.

## X10DRD-LTP Quick Reference

Jumper	Description	Default Setting
JBT1	Clear CMOS	See Section 5-9
J1 <sup>2</sup> C1/J1 <sup>2</sup> C2	SMB to PCI-E Slots	Pins 2-3 (Disabled)
JPB1	BMC Enable/Disable	Pins 1-2 (Enabled)
JPG1	VGA Enable/Disable	Pins 1-2 (Enabled)
JPL1	10Gb SFP+ LAN 1/2 Enable/Disable	Pins 1-2 (Enabled)
JPME2	Manufacturer (ME) Mode Select	Pins 1-2 (Normal)
JWD1	Watch Dog Timer	Pins 1-2 (Reset)

Connector	Description
COM1/COM2	Serial Port/Header
FAN 1- 8	CPU/System Fan Headers
IPMI_LAN	Dedicated IPMI LAN Port
JF1	Control Panel Header
JL1	Chassis Intrusion Header
J1 <sup>2</sup> C1	Power Supply SMBbus I <sup>2</sup> C Header
JPWR1	24-pin ATX main Power Connector
JPWR2/JPWR3	12V 8-pin Power Connectors
JSTBY1	Standby Power Connector
JTPM1	TPM (Trusted Platform Module)/Port 80 Header
I-SATA 0-5	SATA 3.0 Ports (supported by Intel PCH)
I-SGPIO1/2	Serial Link General Purpose I/O Headers for SATA Ports
S-SATA0-3	SATA 3.0 Ports (supported by Intel SCU)
SFP+/LAN1	10Gb SFP+ LAN Port 1
SFP+/LAN2	10Gb SFP+ LAN Port 2
USB 0/1/4/5	Backpanel USB 2.0 Ports
USB 2/3	Front Accessible USB 2.0 Headers
USB 6	Front Accessible Type A 2.0 USB Connector

LED	Description	State	Status
LED1	Rear UID LED	Blue: On	Unit Identified
LED3	SFP+/LAN1 Activity LED	Green: Blinking	SFP+/LAN1 Active
LED4	SFP+/LAN1 Heartbeat LED	Green: Blinking	SFP+/LAN1 Normal
LED5	SFP+/LAN2 Activity LED	Green: Blinking	SFP+/LAN2 Active
LED6	SFP+/LAN1 Heartbeat LED	Green: Blinking	SFP+/LAN2 Normal
LEDM1	BMC Heartbeat LED	Green: Blinking	BMC Normal

## 5-8 Connector Definitions

### Power Connectors

A 24-pin main ATX power supply connector (JPWR1) and two 8-pin CPU power connectors (JPWR2/3) are included on the serverboard. These power connectors meet the SSI EPS 12V specification and must be connected to your power supply to provide adequate power to the system. See the table on the right for pin definitions.

ATX Power 24-pin Connector Pin Definitions (JPW1)			
Pin#	Definition	Pin #	Definition
13	+3.3V	1	+3.3V
14	-12V	2	+3.3V
15	COM	3	COM
16	PS_ON	4	+5V
17	COM	5	COM
18	COM	6	+5V
19	COM	7	COM
20	Res (NC)	8	PWR_OK
21	+5V	9	5VSB
22	+5V	10	+12V
23	+5V	11	+12V
24	COM	12	+3.3V

### 8-Pin Power Connectors

In addition to the ATX main power, two 8-pin 12V power connector located at JPWR2 and JPWR3 are also required connections. See the table on the right for pin definitions.

8-pin Power Pin Definitions (JPW2, JPW3)	
Pins	Definition
1 through 4	Ground
5 through 8	+12V

### NMI Button

The non-maskable interrupt button header is located on pins 19 and 20 of JF1. Refer to the table on the right for pin definitions.

NMI Button Pin Definitions (JF1)	
Pin#	Definition
19	Control
20	Ground

### Power LED

The Power LED connection is located on pins 15 and 16 of JF1. Refer to the table on the right for pin definitions.

Power LED Pin Definitions (JF1)	
Pin#	Definition
15	3.3V
16	PWR LED

### HDD/UID LED

The HDD LED connection is located on pins 13 and 14 of JF1. Attach a cable to pin 14 to indicate HDD activity. Attach a cable to pin 13 to use the UID switch. See the table on the right for pin definitions.

HDD LED Pin Definitions (JF1)	
Pin#	Definition
13	3.3V Standby
14	HD Active

### NIC1/NIC2 LED Indicators

The NIC (Network Interface Controller) LED connection for LAN port 1 is located on pins 11 and 12 of JF1, and the LED connection for LAN Port 2 is on pins 9 and 10. Attach the NIC LED cables here to display network activity. Refer to the table on the right for pin definitions.

NIC1/2 LED Pin Definitions (JF1)	
Pin#	Definition
9	NIC 2 Activity LED
10	NIC 2 Link LED
11	NIC 1 Activity LED
12	NIC 1 Link LED

### Universal Information LED

Connect an LED cable to pins 7 and 8 of JF1 to use the Overheat/Fan Fail/Power Fail and UID LED connections. The red LED on pin 7 provides warnings of overheat, fan failure or power failure. The blue LED on pin 8 works as the front panel UID LED indicator. The red LED takes precedence over the blue LED by default. Refer to the tables on the right for pin definitions.

Universal Information LED Pin Definitions (JF1)	
Pin#	Definition
7	Blue UID LED
8	OH/Fan Fail/Power Fail

OH/Fan Fail/PWR Fail LED Status (Red LED)	
State	Definition
Off	Normal
On	Overheat
Flashing	Fan Fail

### Power Fail LED

The Power Fail LED connection is located on pins 5 and 6 of JF1. Refer to the table on the right for pin definitions.

PWR Fail LED Pin Definitions (JF1)	
Pin#	Definition
5	3.3V
6	PWR Supply Fail

### Reset Button

The Reset Button connection is located on pins 3 and 4 of JF1. Attach it to a hardware reset switch on the computer case. Refer to the table on the right for pin definitions.

Reset Button Pin Definitions (JF1)	
Pin#	Definition
3	Reset
4	Ground

### Power Button

The Power Button connection is located on pins 1 and 2 of JF1. Momentarily contacting both pins will power on/off the system. To turn off the power when the system is in suspend mode, press the button for four seconds or longer. Refer to the table on the right for pin definitions.

Power Button Pin Definitions (JF1)	
Pin#	Definition
1	Signal
2	Ground

### Serial Ports

Two COM connections (COM1 and COM2) are provided on the serverboard. COM1 is located on the I/O back panel. COM2, located close to Slot4 (PCI-E 3.0 x 8), provides front access support.

### Universal Serial Bus (USB)

Four Universal Serial Bus ports (USB 0/1, USB 2/3) are located on the rear I/O panel. In addition, an internal USB header provides two front-accessible USB connections (USB 4/5). One Type A connector (USB6) also supports front panel USB connection. (Cables are not included.)

### 10G SFP+/Ethernet LAN Ports

Two 10 Gigabit SFP+ (Small Form Factor Pluggable) Transceiver and Ethernet LAN ports, supported by the Intel 82599SE, are located on the rear I/O panel. SFP+/LAN ports 1/2 provide NC-SI network connections. In addition, a dedicated IPMI LAN port, supported by the AST2400 BMC (Baseboard Management Controller), is also located on rear I/O panel to provide LAN support for IPMI 2.0. Please refer to the LED Indicator section for SFP+/LAN LED information.

### Unit Identifier Switches/UID LED Indicators

A rear Unit Identifier (UID) switch and a rear UID LED (LED1) are located next to the VGA port. The front UID switch and the UID LED are both located on the front panel control (JF1), with the front UID switch on pin 13 of JF1 and the front LED on pin 7. Pressing either the front or rear UID switch, will turn on both front and rear UID LEDs. Press the UID switch again to turn off the LED indicators. The UID indicators provide easy identification of a system unit that may be in need of service.

**Note:** UID can also be triggered via IPMI on the serverboard. For more information on IPMI, please refer to the IPMI user's guide posted on our website @ <http://www.supermicro.com>.

### Fan Headers

The X10DRD-LTP has eight fan headers (Fan1 ~ Fan8). These are all 4-pin fan headers, however pins 1-3 are backward compatible with traditional 3-pin fans. However, fan speed control is available for 4-pin fans only by Thermal Management via the IPMI 2.0 interface. Refer to the table on the right for pin definitions.

**Note:** Please use all 3-pin fans or all 4-pin fans on a serverboard. Do not mix 3-pin fans and 4-pin fans on the same board.

### Chassis Intrusion

A Chassis Intrusion header is located at JL1 on the serverboard. Attach the appropriate cable from the chassis to inform you of a chassis intrusion when the chassis is opened.

UID Switch	
Pin#	Definition
1	Ground
2	Ground
3	Button In
4	Ground

UID LED (LED3) Status	
Color/State	Status
Blue: On	Unit Identified

Fan Header Pin Definitions	
Pin#	Definition
1	Ground
2	+12V
3	Tachometer
4	PWR Modulation

Chassis Intrusion Pin Definitions	
Pin#	Definition
1	Intrusion Input
2	Ground

### Internal Speaker

The Internal Speaker, located at SP1, can be used to provide audible indications for various beep codes. See the table on the right for pin definitions.

Internal Buzzer (SP1) Pin Definition		
Pin#	Definitions	
Pin 1	Pos. (+)	Beep In
Pin 2	Neg. (-)	Alarm Speaker



### Trusted Platform Module Header

The JTPM1 header is used to connect a Trusted Platform Module (TPM), available separately from a third-party vendor. A TPM is a security device that allows encryption and authentication of hard drives, disallowing access if the TPM associated with it is not installed in the system. See the table on the right for pin definitions.

TPM/Port 80 Header Pin Definitions			
Pin #	Definition	Pin #	Definition
1	LCLK	2	GND
3	LFRAME#	4	<(KEY)>
5	LRESET#	6	+5V (X)
7	LAD 3	8	LAD 2
9	+3.3V	10	LAD1
11	LAD0	12	GND
13	SMB_CLK4	14	SMB_DAT4
15	+3V_DUAL	16	SERIRQ
17	GND	18	CLKRUN# (X)
19	LPCPD#	20	LDRQ# (X)

### Power SMB (I<sup>2</sup>C) Connector

The Power System Management Bus (I<sup>2</sup>C) connector (JP1<sup>2</sup>C1) monitors power supply, fan and system temperatures. See the table on the right for pin definitions.

PWR SMB Pin Definitions	
Pin#	Definition
1	Clock
2	Data
3	PMBUS_Alert
4	Ground
5	+3.3V

### T-SGPIO 0/1 Headers

Two T-SGPIO (Serial-Link General Purpose Input/Output) headers are included to communicate with the enclosure management chip in the system. I-SGPIO1 supports onboard I-SATA 0-3 ports, while I-SGPIO2 supports I-SATA 4/5. See the table on the right for pin definitions.

Serial_Link-SGPIO Pin Definitions			
Pin#	Definition	Pin	Definition
1	NC	2	NC
3	Ground	4	DATA Out
5	Load	6	Ground
7	Clock	8	NC

NC = No connection

### Standby Power Header

The +5V Standby Power header is located at JSTBY1 on the serverboard. See the table on the right for pin definitions. (You must also have a card with a Standby Power connector and a cable to use this feature.)

Standby PWR Pin Definitions	
Pin#	Definition
1	+5V Standby
2	Ground
3	Wake-up

## 5-9 Jumper Settings

### Explanation of Jumpers

To modify the operation of the serverboard, jumpers can be used to choose between optional settings. Jumpers create shorts between two pins to change the function of the connector. Pin 1 is identified with a square solder pad on the printed circuit board. See the diagram at right for an example of jumping pins 1 and 2. Refer to the serverboard layout page for jumper locations.

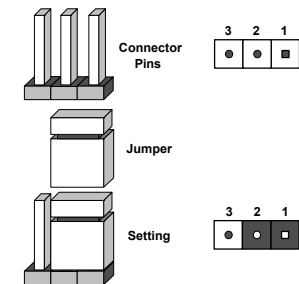

**Note:** Ontwo-pin jumpers, "Closed" means the jumper is on and "Open" means the jumper is off the pins.

### CMOS Clear

JBT1 is used to clear CMOS and will also clear any passwords. Instead of pins, this jumper consists of contact pads to prevent accidentally clearing the contents of CMOS.

#### To Clear CMOS

1. First power down the system and unplug the power cord(s).
2. With the power disconnected, short the CMOS pads with a metal object such as a small screwdriver.
3. Remove the screwdriver (or shorting device).
4. Reconnect the power cord(s) and power on the system.

**Note:** Do not use the PW\_ON connector to clear CMOS.

### VGA Enable/Disable

JPG1 allows you to enable or disable the VGA port. The default position is on pins 1 and 2 to enable VGA. See the table on the right for jumper settings.

VGA Enable/Disable Jumper Settings (JPG1)	
Jumper Setting	Definition
Pins 1-2	Enabled
Pins 2-3	Disabled

### I<sup>2</sup>C Bus to PCI-Express Slots

Use Jumpers JI<sup>2</sup>C1 and JI<sup>2</sup>C2 to connect the System Management Bus (I<sup>2</sup>C) to PCI-Express slots to improve PCI performance. These two jumpers should be set at the same time. See the table on the right for jumper settings.

I <sup>2</sup> C for PCI-E slots Jumper Settings	
Jumper Setting	Definition
Pins 1-2	Enabled
Pins 2-3	Disabled

### SFP+/LAN 1/2 Enable/Disable

JPL1 enables or disables the 10Gb SFP+/LAN ports. See the table on the right for jumper settings.

SFP+/LAN 1/2 Enable Jumper Settings	
Jumper Setting	Definition
Pins 1-2	Enabled
Pins 2-3	Disabled

### BMC Enable/Disable

Jumper JPB1 allows you to enable the embedded Aspeed AST2400 Baseboard Management Controller (BMC) to provide IPMI 2.0/KVM support on the serverboard. See the table on the right for jumper settings.

BMC IPMI Enable/Disable Jumper Settings	
Settings	Definition
Pins 1-2	Enabled
Pins 2-3	Disabled

### Watch Dog Enable

Watch Dog is a system monitor that can reboot the system when a software application hangs. Close pins 1-2 to reset the system if an application hangs. Close pins 2-3 to generate a non-maskable interrupt signal for the application that hangs. See the table on the right for jumper settings. Watch Dog must also be enabled in the BIOS.

Watch Dog Jumper Settings	
Jumper Setting	Definition
Pins 1-2	Reset (default)
Pins 2-3	NMI
Open	Disabled

### Manufacturer Mode Select

Close pins 2 and 3 of JPME2 to bypass SPI flash security and force the system to operate in the manufacturer mode, which will allow the user to flash the system firmware from a host server for system setting modifications.

ME Mode Select Jumper Settings	
Jumper Setting	Definition
Pins 1-2	Normal (Default)
Pins 2-3	Manufacture Mode

## 5-10 Onboard Indicators

### SFP+/LAN1/LAN2 LEDs

The SFP+/LAN 1 Activity LED is located at LED3, and SFP+/LAN 2 Activity LED is located at LED5. When LED3 is blinking, SFP+/LAN1 is active. When LED5 is blinking, SFP+/LAN2 is active. See the table on the right.

SFP+/LAN 1 & 2 Activity LEDs Status	
Color/State	Definition
LED3: Green: Blinking	SFP+/LAN1: Active
LED5: Green: Blinking	SFP+/LAN2: Active

### SFP+/LAN 1/2 Heartbeat LEDs

The SFP+/LAN 1 Heartbeat LED is located at LED4, and SFP+/LAN 2 Heartbeat LED is located at LED6 on the serverboard. When LED4 is blinking, SFP+/LAN1 is working properly. When LED6 is blinking, SFP+/LAN2 is working properly. See the table on the right for more information.

SFP+/LAN 1 & 2 Heartbeat LEDs Status	
Color/State	Definition
LED4: Green: Blinking	SFP+/LAN1: Normal
LED6: Green: Blinking	SFP+/LAN2: Normal

### IPMI Dedicated LAN

In addition to the LAN ports, a dedicated IPMI LAN port is also included on the X10DRD-LTP. The amber LED on the right indicates activity, while the green LED on the left indicates the speed of the connection. See the table at right for more information.

IPMI LAN Link LED (Left) & Activity LED (Right)		
	Color/State	Definition
Link (Left)	Green: Solid Amber: Solid	100 Mbps 1 Gbps
Activity (Right)	Amber: Blinking	Active

### BMC Heartbeat LED

A BMC Heartbeat LED is located at LEDM1 on the serverboard. When LEDM1 is blinking, the BMC is functioning normally. See the table at right for more information.

BMC Heartbeat LED Status	
Color/State	Definition
Green: Blinking	BMC: Normal

## 5-11 SATA Drive Ports

### SATA Ports

Six SATA 3.0 ports (I-SATA 0-5), supported by the Intel PCH C612, are located on the serverboard. Note that I-SATA 4/5 also support Supermicro SuperDOMs, which are yellow SATADOM (Device-On-Module) connectors with power pins built in, and do not require separate external power cables. SuperDOMs are backward-compatible with non-Supermicro SATADOMs that require the external power supply.

## 5-12 Installing Drivers

The Supermicro FTP site contains drivers and utilities for your system at <ftp://ftp.supermicro.com>. Some of these must be installed, such as the chipset driver.

After accessing the FTP site, go into the CDR\_Images directory and locate the ISO file for your serverboard. Download this file to create a CD/DVD of the drivers and utilities it contains. (You may also use a utility to extract the ISO file if preferred.)

Another option is to go to the Supermicro Website at <http://www.supermicro.com/products/>. Find the product page for your serverboard here, where you may download individual drivers and utilities.

After creating a CD/DVD with the ISO files, insert the disk into the CD/DVD drive on your system and the display shown in Figure 5-5 should appear.

Figure 5-5. Driver Installation Display Screen



**Note:** Click the icons showing a hand writing on paper to view the readme files for each item. Click the computer icons to the right of these items to install each item (from top to the bottom) one at a time. **After installing each item, you must re-boot the system before moving on to the next item on the list.** The bottom icon with a CD on it allows you to view the entire contents.



## SuperDoctor® 5

The Supermicro SuperDoctor 5 is a program that functions in a command-line or web-based interface in Windows and Linux operating systems. The program monitors system health information such as CPU temperature, system voltages, system power consumption, fan speed, and provides alerts via email or Simple Network Management Protocol (SNMP).

SuperDoctor 5 comes in local and remote management versions and can be used with Nagios to maximize your system monitoring needs. With SuperDoctor 5 Management Server (SSM Server), you can remotely control power on/off and reset chassis intrusion for multiple systems with SuperDoctor 5 or IPMI. SD5 Management Server monitors HTTP, FTP, and SMTP services to optimize the efficiency of your operation.

**Note:** The default User Name and Password for SuperDoctor 5 is admin / admin.

**Figure 5-6. SuperDoctor 5 Interface Display Screen (Health Information)**



**Note:** The SuperDoctor 5 program and User's Manual can be downloaded from the Supermicro web site at [http://www.supermicro.com/products/info/sms\\_sd5.cfm](http://www.supermicro.com/products/info/sms_sd5.cfm).

## 5-13 Onboard Battery

Care must be taken to assure that the chassis cover is in place when the system is operating to assure proper cooling. Out of warranty damage to the system can occur if this practice is not strictly followed.

**Figure 5-7. Installing the Onboard Battery**

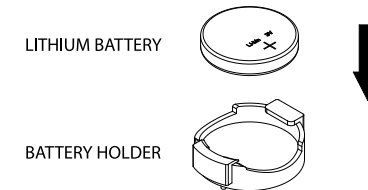

Please handle used batteries carefully. Do not damage the battery in any way; a damaged battery may release hazardous materials into the environment. Do not discard a used battery in the garbage or a public landfill. Please comply with the regulations set up by your local hazardous waste management agency to dispose of your used battery properly.

## Notes

## Chapter 6

### Advanced Chassis Setup

This chapter covers the steps required to install components and perform maintenance on the SC815TQ-600CB/SC815TQ-R500CB chassis. For component installation, follow the steps in the order given to eliminate the most common problems encountered. If some steps are unnecessary, skip ahead to the next step.

**Tools Required:** The only tool you will need to install components and perform maintenance is a Philips screwdriver.

#### 6-1 Static-Sensitive Devices

Electrostatic Discharge (ESD) can damage electronic components. To prevent damage to any printed circuit boards (PCBs), it is important to handle them very carefully. The following measures are generally sufficient to protect your equipment from ESD damage.

##### Precautions

- Use a grounded wrist strap designed to prevent static discharge.
- Touch a grounded metal object before removing any board from its antistatic bag.
- Handle a board by its edges only; do not touch its components, peripheral chips, memory modules or gold contacts.
- When handling chips or modules, avoid touching their pins.
- Put the serverboard, add-on cards and peripherals back into their antistatic bags when not in use.
- For grounding purposes, make sure your computer chassis provides excellent conductivity between the power supply, the case, the mounting fasteners and the serverboard.

Figure 6-1. Front and Rear Views

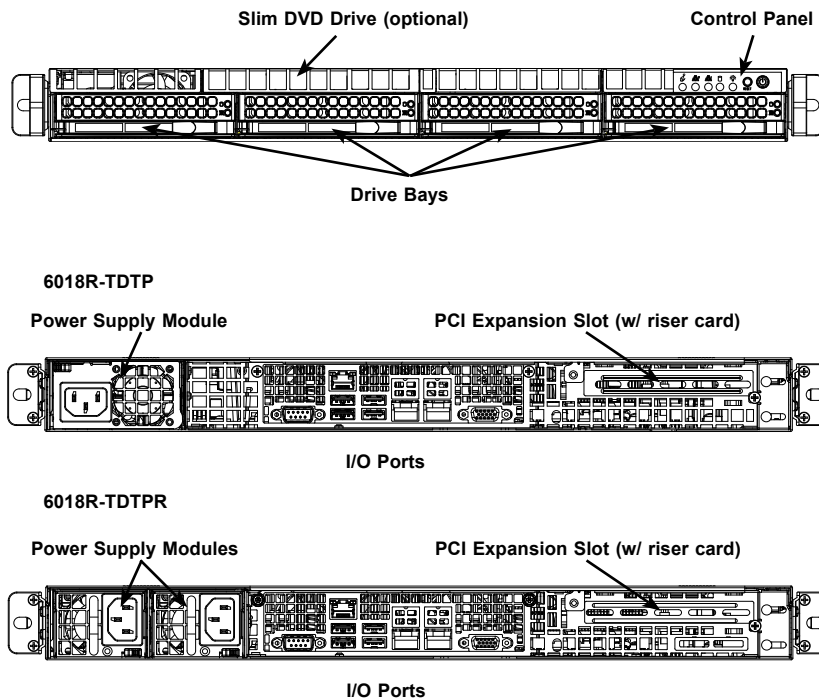

## 6-2 Control Panel

The control panel (located on the front of the chassis) must be connected to the JF1 connector on the serverboard to provide you with system status indications. These wires have been bundled together as a ribbon cable to simplify the connection.

Connect the cable from JF1 on the serverboard to the appropriate header on the Control Panel PCB (printed circuit board). Make sure the red wire plugs into pin 1 on both connectors. Pull all excess cabling out of the airflow path.

The control panel LEDs inform you of system status. See "Chapter 3: System Interface" for details on the LEDs and the control panel buttons. Details on JF1 can be found in "Chapter 5: Advanced Serverboard Setup."

## 6-3 System Fans

Five 4-cm heavy duty counter-rotating fans provide the cooling for the SuperServer 6018R-TDTP/TDTPR. Each fan unit is actually made up of two fans joined back-to-back, which rotate in opposite directions. This counter-rotating action generates exceptional airflow and works to dampen vibration levels. It is very important that the chassis top cover is properly installed and making a good seal in order for the cooling air to circulate properly through the chassis and cool the components. See Figure 6-2.

### System Fan Failure

Fan speed is controlled via IPMI. If a fan fails, the remaining fan will ramp up to full speed and the overheat/fan fail LED on the control panel will turn on. Replace any failed fan at your earliest convenience with the same type and model (the system can continue to run with a failed fan).

Remove the top chassis cover while the system is still running to determine which of the two fans has failed. Then power down the system before replacing a fan. Removing the power cords is also recommended as a safety precaution.

### Replacing System Fans

1. After determining which fan has failed, turn off the power to the system.
2. Unplug the fan cable from the serverboard and remove the failed blower fan from the chassis.
3. Replace the failed fan with an identical 4-cm fan (available from Supermicro).
4. Push the new fan into the vacant space in the housing while making sure the arrows on the top of the fan (indicating air direction) point in the same direction as the arrows on the other fans.
5. Reposition the fan housing back over the two mounting posts in the chassis, then reconnect the fan wires to the same chassis fan headers you removed them from.
6. Power up the system and check that the fan is working properly and that the LED on the control panel has turned off. Finish by replacing the chassis cover.

Figure 6-2. System Cooling Fans

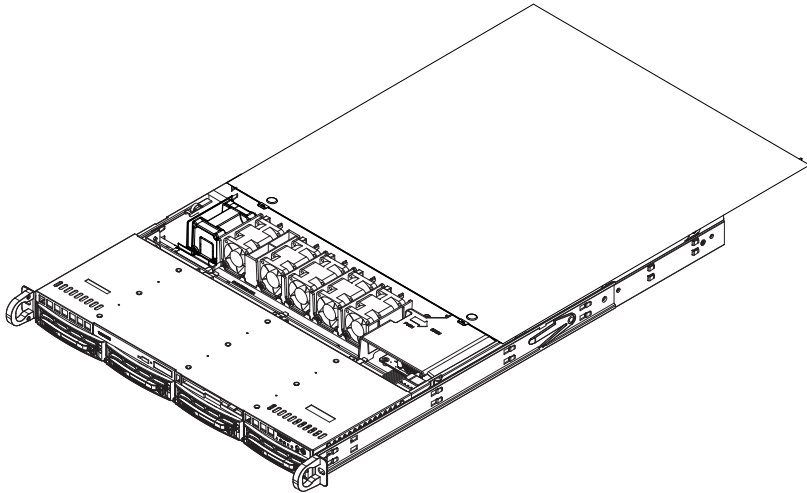

## 6-4 Drive Bay Installation/Removal

### Removing the Front Bezel

If your system has a front bezel (optional) attached to the chassis, you must first remove it to gain access to the drive bays. To remove the bezel, first unlock the front of the chassis then press the release knob (see Figure 6-3). Carefully remove the bezel with both hands. A filter located within the bezel can be removed for replacement/cleaning. It is recommended that you keep a maintenance log of filter cleaning/replacement, since its condition will affect the airflow throughout the whole system.

Figure 6-3. Removing the Front Bezel

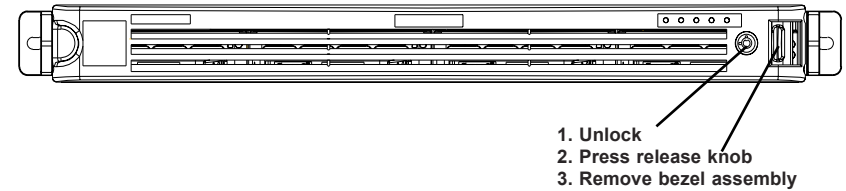

### Accessing the Drive Bays

**SATA Drives:** Because of their hotswap capability, you do not need to access the inside of the chassis or power down the system to install or replace SATA drives. Proceed to the next section for instructions.

**DVD-ROM Drive:** For installing/removing a DVD-ROM drive, you will need to gain access to the inside of the 6018R-TDTP/TDTPR by removing the top cover of the chassis. Proceed to the "DVD-ROM Drive Installation" section later in this chapter for instructions.

**Note:** Only a "slim" DVD-ROM drive will fit into the 6018R-TDTP/TDTPR.

## Hard Drive Installation

The hard drives are mounted in drive carriers to simplify their installation and removal from the chassis. These carriers also help promote proper airflow for the drive bays. For this reason, even empty carriers without drives installed must remain in the chassis.

### Mounting a Hard Drive in a Drive Carrier

1. Insert a drive into the carrier with the printed circuit board side facing down so that the mounting holes align with those in the carrier.
2. Secure the drive to the carrier with four screws, as shown in Figure 6-4.

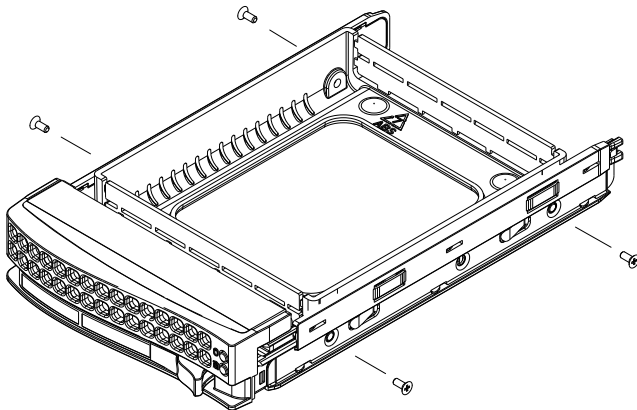

Figure 6-4. Mounting a Hard Drive in a Carrier

**Warning:** Use caution when working around the SATA backplane. Do not touch the backplane with any metal objects and make sure no ribbon cables touch the backplane or obstruct the holes, which aid in proper airflow.

**Warning:** Enterprise level hard disk drives are recommended for use in Supermicro chassis and servers. For information on recommended HDDs, visit the Supermicro website at <http://www.supermicro.com/products/info/storage.cfm>

### Installing/Removing a Hard Drive

1. To remove a carrier, push the release button located beside the drive LEDs.
2. Swing the colored handle fully out and use it to pull the unit straight out (see Figure 6-5).

**Note:** Your operating system must have RAID support to enable the hot-plug capability of the hard drives.

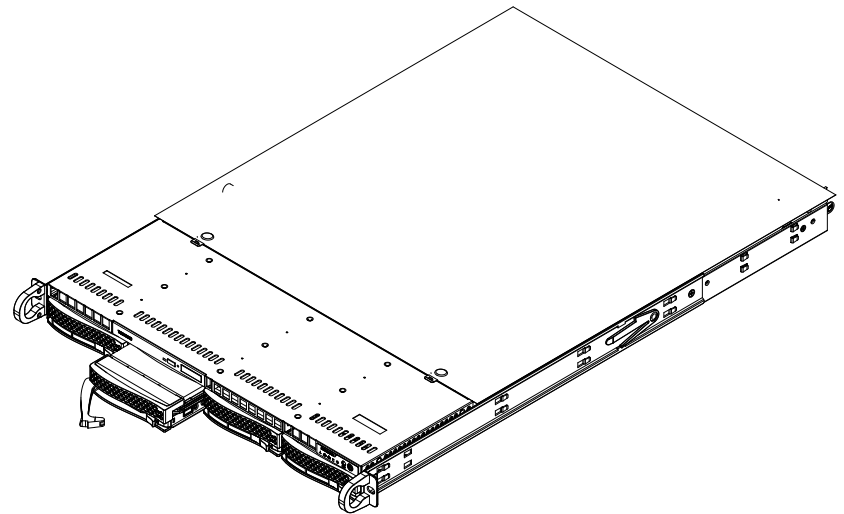

Figure 6-5. Removing a Hard Drive from the Server

**Warning:** Regardless of how many hard drives are installed, all drive carriers must remain in the drive bays to maintain proper airflow.

## DVD-ROM Drive Installation

The top cover of the chassis must be opened to gain full access to the DVD-ROM drive bay. The 6018R-TDTP/TDTPR accommodates only slim-line DVD-ROM drives. Side mounting brackets are needed to mount a slim-line DVD-ROM drive in the 6018R-TDTP/TDTPR server. You must power down the system before installing or removing a DVD-ROM drive.

### **Removing the Chassis Cover**

1. Grasp the two handles on either side and pull the unit straight out until it locks (you will hear a "click").
2. Depress the two buttons on the top of the chassis to release the top cover. At the same time, push the cover away from you until it stops. You can then lift the top cover from the chassis to gain full access to the inside of the server.

### **Removing/Installing a Drive**

1. With the chassis cover removed, unplug the power and data cables from the drive you want to remove.
2. Locate the locking tab at the rear of the drive. It will be on the left side of the drive when viewed from the front of the chassis.
3. Pull the tab away from the drive and push the drive unit out the front of the chassis.
4. Add a new drive by following this procedure in reverse order. You may hear a faint \*click\* of the locking tab when the drive is fully inserted.
5. Remember to reconnect the data and power cables to the drive before replacing the chassis cover and restoring power to the system.

## 6-5 Power Supply

The SuperServer 6018R-TDTP has a single 600 watt power supply while the 6018R-TDTPR features a redundant, 500W hot-plug power supply. Both are auto-switching capable, enabling the power modules to automatically sense and operate with a 100V - 240V input voltage.

### **Power Supply Failure**

#### **6018R-TDTP**

If the power supply module fails, the system will shut down and you will need to replace the module. Replacements can be ordered directly from Supermicro (see contact information in the Preface). As there is only one power supply module in the server, power must be completely removed before removing and replacing the power supply for whatever reason.

#### **Replacing the Power Supply**

1. With the power shut down, unplug the AC power cord from the power supply.
2. Extend the chassis from the rack if necessary, then remove the top chassis cover.
3. To remove the failed power unit, remove the two screws that secure the power module to its housing inside the chassis. You can then pull the unit straight out of the chassis.
4. Replace the failed unit with another unit of the same wattage. You must replace it with the exact same power supply (same model number).
5. Carefully insert the new unit into position into the chassis and secure it with the two screws you removed previously.
6. Reconnect the AC power cord, replace the top chassis cover and push the unit back into the rack.
7. Finish by powering up the server with the power button on the front control panel.

### 6018R-TDTPR

An amber light will be illuminated on the power supply when the power is off. An illuminated green light indicates that the power supply is operating. If either of the two power supply modules fail, the other module will take the full load and allow the system to continue operation without interruption. A power fail condition will be displayed on the front control panel until the failed unit has been replaced.

Replacement units can be ordered directly from Supermicro. The power supply units have a hot-swap capability, meaning you can replace the failed unit without powering down the system.

### Removing/Replacing the Power Supply

You do not need to shut down the system to replace a power supply unit. The backup power supply module will keep the system up and running while you replace the failed hot-swap unit. Replace with the same model (see part number in the Appendix), which can be ordered directly from Supermicro.

#### Removing the Power Supply

1. First unplug the AC power cord from the failed power supply module.
2. Depress the release tab on the power supply module.
3. Use the handle to pull it straight out with the rounded handle.

#### Installing a New Power Supply

1. Replace the failed hot-swap unit with another identical power supply unit.
2. Push the new power supply unit into the power bay until you hear a click.
3. Finish by plugging the AC power cord back into the new module.

Figure 6-6. Removing/Replacing the Power Supply

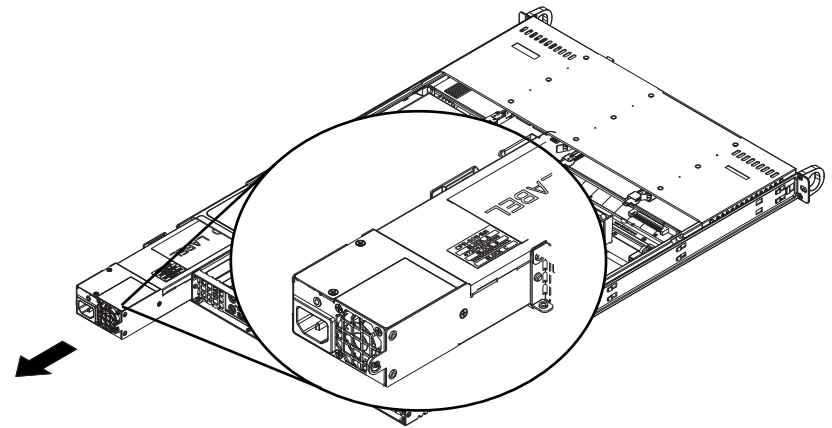



## Notes

# Chapter 7

## BIOS

### 7-1 Introduction

This chapter describes the AMI BIOS setup utility for the X10DRD-iTP/INTP/LTP. The ROM BIOS is stored in a Flash EEPROM and can be easily updated. This chapter describes the basic navigation of the AMI BIOS setup utility screens.

**Note:** For AMI BIOS recovery, please refer to the UEFI BIOS Recovery Instructions in Appendix C.

#### Starting BIOS Setup Utility

To enter the AMI BIOS setup utility screens, press the <Delete> key while the system is booting up.

**Note:** In most cases, the <Delete> key is used to invoke the AMI BIOS setup screen. There are a few cases when other keys are used, such as <F1>, <F2>, etc.

Each main BIOS menu option is described in this manual. The AMI BIOS setup menu screen has two main frames. The left frame displays all the options that can be configured. Grayed-out options cannot be configured. Options in blue can be configured by the user. The right frame displays the key legend. Above the key legend is an area reserved for a text message. When an option is selected in the left frame, it is highlighted in white. Often a text message will accompany it.

**Note:** the AMI BIOS has default text messages built in. Supermicro retains the option to include, omit, or change any of these text messages.

The AMI BIOS setup utility uses a key-based navigation system called "hot keys." Most of the AMI BIOS setup utility "hot keys" can be used at any time during the setup navigation process. These keys include <F1>, <F4>, <Enter>, <Esc>, arrow keys, etc.

**Note:** Options printed in **Bold** are default settings.

#### How To Change the Configuration Data

The configuration data that determines the system parameters may be changed by entering the AMI BIOS setup utility. This setup utility can be accessed by pressing <Del> at the appropriate time during system boot.

## How to Start the Setup Utility

Normally, the only visible Power-On Self-Test (POST) routine is the memory test. As the memory is being tested, press the <Delete> key to enter the main menu of the AMI BIOS setup utility. From the main menu, you can access the other setup screens. An AMI BIOS identification string is displayed at the left bottom corner of the screen, below the copyright message.

**Warning:** Do not upgrade the BIOS unless your system has a BIOS-related issue. Flashing the wrong BIOS can cause irreparable damage to the system. In no event shall Supermicro be liable for direct, indirect, special, incidental, or consequential damages arising from a BIOS update. If you have to update the BIOS, do not shut down or reset the system while the BIOS is updating. This is to avoid possible boot failure.

## 7-2 Main Setup

When you first enter the AMI BIOS setup utility, you will enter the Main setup screen. You can always return to the Main setup screen by selecting the Main tab on the top of the screen. The Main BIOS setup screen is shown below.

The following Main menu items will be displayed:



## System Date/System Time

Use this option to change the system date and time. Highlight *System Date* or *System Time* using the arrow keys. Enter new values using the keyboard. Press the <Tab> key or the arrow keys to move between fields. The date must be entered in Day MM/DD/YYYY format. The time is entered in HH:MM:SS format.

**Note:** The time is in the 24-hour format. For example, 5:30 P.M. appears as 17:30:00.

## Supermicro X10DRD-i

**BIOS Version:** This item displays the version of the BIOS ROM used in the system.

**Build Date:** This item displays the date when the version of the BIOS ROM used in the system was built.

## Memory Information

**Total Memory:** This item displays the total size of memory available in the system.

**Memory Speed:** This item displays the default speed of the memory modules installed in the system.

## 7-3 Advanced Setup Configurations

Use the arrow keys to select Advanced setup and press <Enter> to access the submenu items:

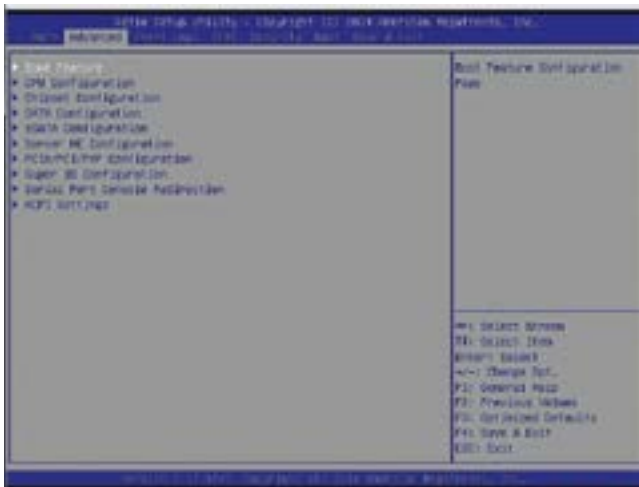

**Warning:** Take Caution when changing the Advanced settings. An incorrect value, a very high DRAM frequency or an incorrect timing setting may cause the system to malfunction. When this occurs, restore the setting to the manufacture default setting.

### ► Boot Feature

#### Quiet Boot

Use this feature to select the screen display between POST messages or the OEM logo at bootup. Select Disabled to display the POST messages. Select Enabled to display the OEM logo instead of the normal POST messages. The options are **Enabled** and **Disabled**.

#### AddOn ROM Display Mode

Use this item to set the display mode for the Option ROM. Select Keep Current to use the current AddOn ROM display setting. Select Force BIOS to use the Option ROM display mode set by the system BIOS. The options are **Force BIOS** and **Keep Current**.

#### Startup NumLock State

Use this feature to set the Power-on state for the NumLock key. The options are **Off** and **On**.

#### Wait For 'F1' If Error

Select Enabled to force the system to wait until the 'F1' key is pressed if an error occurs. The options are **Disabled** and **Enabled**.

#### INT19 (Interrupt 19) Trap Response

Interrupt 19 is the software interrupt that handles the boot disk function. When this item is set to Immediate, the ROM BIOS of the host adaptors will "capture" Interrupt 19 at bootup immediately and allow the drives that are attached to these host adaptors to function as bootable disks. If this item is set to Postponed, the ROM BIOS of the host adaptors will not capture Interrupt 19 immediately and allow the drives attached to these adaptors to function as bootable devices at bootup. The options are **Immediate** and **Postponed**.

#### Re-try Boot

When EFI Boot is selected, the system BIOS will automatically reboot the system from an EFI boot device after its initial boot failure. Select Legacy Boot to allow the BIOS to automatically reboot the system from a Legacy boot device after its initial boot failure. The options are **Disabled**, **Legacy Boot**, and **EFI Boot**.

## Power Configuration

#### Watch Dog Function

Select Enabled to allow the Watch Dog timer to reboot the system when it is inactive for more than 5 minutes. The options are **Enabled** and **Disabled**.

#### Power Button Function

This feature controls how the system shuts down when the power button is pressed. Select 4 Seconds Override for the user to power off the system after pressing and holding the power button for 4 seconds or longer. Select Instant Off to instantly power off the system as soon as the user presses the power button. The options are **4 Seconds Override** and **Instant Off**.

#### Restore on AC Power Loss

Use this feature to set the power state after a power outage. Select Power-Off for the system power to remain off after a power loss. Select Power-On for the system power to be turned on after a power loss. Select Last State to allow the system to resume its last power state before a power loss. The options are **Power On**, **Stay Off** and **Last State**.

## ►CPU Configuration

This submenu displays the information of the CPU as detected by the BIOS. It also allows the user to configuration CPU settings.

### Socket 1 CPU Information/Socket 2 CPU Information

This submenu displays the following information regarding the CPU installed in Socket 1 and (or) Socket 2 as detected by the BIOS.

- Processor Socket
- Processor ID
- Processor Frequency
- Processor Maximum Ratio
- Processor Minimum Ratio
- Microcode Revision
- L1 Cache RAM
- L2 Cache RAM
- L3 Cache RAM
- CPU 1 Version
- CPU 2 Version

### Clock Spread Spectrum

Select Enabled to enable Clock Spectrum support, which will allow the BIOS to monitor and attempt to reduce the level of Electromagnetic Interference caused by the components whenever needed. The options are **Disabled** and Enabled.

### Hyper-Threading (ALL)

Select Enabled to support Intel Hyper-threading Technology to enhance CPU performance. The options are **Enabled** and Disabled.

### Cores Enabled

Set a numeric value to enable the number of cores. (Please refer to Intel's website for more information.) Enter **0** to enable all cores.

### Execute Disable Bit (Available if supported by the OS & the CPU)

Select Enable to enable the Execute-Disable Bit technology which will allow the processor to designate areas in the system memory where an application code can execute and where it cannot, thus preventing a worm or a virus from flooding illegal codes to overwhelm the processor or damage the system during an attack. The options are **Enable** and Disable. (Refer to Intel and Microsoft Web sites for more information.)

### PPIN Control

Select Unlock/Enable to use the Protected-Processor Inventory Number (PPIN) in the system. The options are **Unlock/Enable** and Unlock/Disable.

### Hardware Prefetcher (Available when supported by the CPU)

If set to Enable, the hardware prefetcher will prefetch streams of data and instructions from the main memory to the L2 cache to improve CPU performance. The options are Disable and **Enable**.

### Adjacent Cache Prefetch (Available when supported by the CPU)

If this feature is set to Disable, the CPU prefetches the cache line for 64 bytes. If this feature is set to **Enable**, the CPU prefetches both cache lines for 128 bytes as comprised. The options are Disable and **Enable**.

### DCU Streamer Prefetcher (Available when supported by the CPU)

Select Enable to enable the DCU (Data Cache Unit) Streamer Prefetcher which will stream and prefetch data and send it to the Level 1 data cache to improve data processing and system performance. The options are Disable and **Enable**.

### DCU IP Prefetcher (Available when supported by the CPU)

Select Enable for DCU (Data Cache Unit) IP Prefetcher support, which will prefetch IP addresses to improve network connectivity and system performance. The options are Disable and **Enable**.

### Direct Cache Access (DCA)

Select Enable to use Intel's DCA (Direct Cache Access) Technology to improve data transfer efficiency. The options are Disable, Enable, and **Auto**.

### X2APIC

Select Enable to activate APIC (Advanced Programmable Interrupt Controller) support. The options are Enable and **Disable**.

### Intel Virtualization Technology (Available when supported by the CPU)

Select Enable to support Intel Virtualization Technology, which will allow one platform to run multiple operating systems and applications in independent parti-

tions, creating multiple "virtual" systems in one physical computer. The options are **Enable** and **Disable**.

 **Note:** If a change is made to this setting, you will need to reboot the system for the change to take effect. Refer to Intel's website for detailed information.

## ► Chipset Configuration

### ► North Bridge

This feature allows the user to configure the settings for the Intel North Bridge.

### ► I/O Configuration

#### EV DFX (Device Function On-Hide) Features

When this feature is set to **Enable**, the EV\_DFX Lock bits that are located on a processor will always remain clear during electric tuning. The options are **Disable** and **Enable**.

### ► I/O1 Configuration

#### CPU1 SLOT5 PCI-E 3.0 x8

Use this feature to set the PCI-Exp bus speed for the slot specified above. The options are Gen (Generation) 1 (2.5 GT/s), Gen (Generation) 2 (5 GT/s), and Gen (Generation) 3 (8 GT/s).

#### CPU1 SLOT6 PCI-E 3.0 x8

Use this feature to set the PCI-Exp bus speed for the slot specified above. The options are Gen (Generation) 1 (2.5 GT/s), Gen (Generation) 2 (5 GT/s), and Gen (Generation) 3 (8 GT/s).

#### CPU1 SLOT4 PCI-E 3.0 x8

Use this feature to set the PCI-Exp bus speed for the slot specified above. The options are Gen (Generation) 1 (2.5 GT/s), Gen (Generation) 2 (5 GT/s), and Gen (Generation) 3 (8 GT/s).

## ► I/O2 Configuration

### CPU2 SLOT7 PCI-E 3.0 x8

Use this feature to set the PCI-Exp bus speed for the slot specified above. The options are Gen (Generation) 1 (2.5 GT/s), Gen (Generation) 2 (5 GT/s), and Gen (Generation) 3 (8 GT/s).

## ► IOAT Configuration

### Enable IOAT (I/O Acceleration Technology)

Select **Enable** to enable Intel I/OAT (I/O Acceleration Technology), which significantly reduces CPU overhead by leveraging CPU architectural improvements and freeing the system resource for other tasks. The options are **Enable** and **Disable**.

### No Snoop

Select **Enable** to support no-snoop mode for each CB device. The options are **Disable** and **Enable**.

### Relaxed Ordering

Select **Enable** to enable Relaxed Ordering support which will allow certain transactions to violate the strict-ordering rules of PCI and to be completed prior to other transactions that have already been enqueued. The options are **Disable** and **Enable**.

## ► Intel VT for Directed I/O (VT-d)

### Intel VT for Direct I/O (VT-d)

#### Intel® VT for Directed I/O (VT-d)

Select **Enable** to enable Intel Virtualization Technology support for Direct I/O VT-d support by reporting the I/O device assignments to the VMM (Virtual Machine Monitor) through the DMAR ACPI tables. This feature offers fully-protected I/O resource sharing across Intel platforms, providing greater reliability, security and availability in networking and data-sharing. The options are **Enable** and **Disable**.

### Interrupt Remapping

Select **Enable** for Interrupt Remapping support to enhance system performance. The options are **Enable** and **Disable**.

## ► QPI (Quick Path Interconnect) Configuration

The following QPI information will be displayed:

- **Number of CPU**
- **Number of IIO**
- **Current QPI Link Speed:** This item displays the current QPI Link speed.
- **Current QPI Link Frequency:** This item displays the frequency of the QPI Link.
- **QPI Global MMIO Low Base / Limit**
- **QPI Global MMIO High Base / Limit**
- **QPI PCI-E Configuration Base / Size**

### Link Frequency Select

Use this feature to select the desired QPI link frequency. The options are 6.4 GT/s, 8.0 GT/s, 9.6 GT/s, **Auto**, and Auto Limited.

### Link L0p Enable

Select Enable for the QPI to enter the L0p state for power saving. The options are Disable and **Enable**.

### Link L1 Enable

Select Enable for the QPI to enter the L1 state for power saving. The options are Disable and **Enable**.

### COD Enable (Available when the OS and the CPU support this feature)

Select Enable for Cluster-On-Die support to enhance system performance in cloud computing. The options are Enable, Disable, and **Auto**.

### Early Snoop (Available when the OS and the CPU support this feature)

Select Enable for Early Snoop support to enhance system performance. The options are Enable, Disable, and **Auto**.

### Isoc Mode

Select Enable to enable Isochronous support to meet QoS (Quality of Service) requirements. This feature is especially important for Virtualization Technology. The options are Enable and **Disable**.

## ► Memory Configuration

### Integrated Memory Controller (IMC)

#### Enforce POR

Select Enable to enforce POR restrictions on DDR4 frequency and voltage programming. The options are **Enabled** and Disabled.

#### Memory Frequency

Use this feature to set the maximum memory frequency for onboard memory modules. The options are **Auto**, 1333, 1400, 1600, 1800, 1867, 2000, 2133, 2200, and 2400.

#### Data Scrambling

Select Enabled to enable data scrambling to enhance system performance and data integrity. The options are **Auto**, Disabled and Enabled.

#### DRAM RAPL (Running Average Power Limit) Baseline

Use this feature to set the run-time power-limit baseline for DRAM modules. The options are Disable, DRAM RAPL Mode 0, and **DRAM RAPL Mode 1**.

#### Set Throttling Mode

Throttling improves reliability and reduces power consumption in the processor via automatic voltage control during processor idle states. The options are Disabled and **CLTT** (Closed Loop Thermal Throttling).

#### Socket Interleave Below 4GB

Select Enable for the memory above the 4G Address space to be split between two sockets. The options are Enable and **Disable**.

#### A7 Mode

Select Enable to support A7 (Addressing) mode to improve memory performance. The options are **Enable** and Disable.

## ► DIMM Information

This item displays the status of a DIMM module specified by the user.

- P1-DIMMA1
- P1-DIMMB1
- P1-DIMMC1

- P1-DIMMD1
- P2-DIMME1
- P2-DIMMF1
- P2-DIMMG1
- P2-DIMMH1

### ►Memory RAS (Reliability\_Availability\_Serviceability) Configuration

Use this submenu to configure the following Memory RAS settings.

#### Memory RAS Configuration Setup

##### RAS Mode

When Disable is selected, RAS is not supported. When Mirror is selected, the motherboard maintains two identical copies of all data in memory for data backup. When Lockstep is selected, the motherboard uses two areas of memory to run the same set of operations in parallel to boost performance. The options are **Disable**, Mirror, and Lockstep Mode.

##### Memory Rank Sparing

Select Enabled to enable memory-sparing support for memory ranks to improve memory performance. The options are **Disabled** and Enabled.

##### Patrol Scrub

Patrol Scrubbing is a process that allows the CPU to correct correctable memory errors detected on a memory module and send the correction to the requestor (the original source). When this item is set to Enabled, read-and-write will be performed every 16K cycles per cache line if there is no delay caused by internal processing. The options are **Enable** and Disable.

##### Patrol Scrub Interval

This feature allows you to decide how many hours the system should wait before the next complete patrol scrub is performed. Use the keyboard to enter a value from 0-24.

##### Demand Scrub

Demand Scrubbing is a process that allows the CPU to correct correctable memory errors found on a memory module. When the CPU or I/O issues a demand-read command, and the read data from memory turns out to be a

correctable error, the error is corrected and sent to the requestor (the original source). Memory is updated as well. Select Enable to use Demand Scrubbing for ECC memory correction. The options are **Enable** and Disable.

##### Device Tagging

Select Enable to support device tagging. The options are **Disable** and Enable.

### ►South Bridge Configuration

The following South Bridge information will display:

#### ►USB Configuration

- USB Module Version
- USB Devices

#### Legacy USB Support

Select Enabled to support onboard legacy USB devices. Select Auto to disable legacy support if there are no legacy USB devices present. Select Disable to have all USB devices available for EFI applications only. The options are **Enabled**, Disabled and Auto.

#### EHCI Hand-Off

This item is for operating systems that do not support Enhanced Host Controller Interface (EHCI) hand-off. When this item is enabled, EHCI ownership change will be claimed by the EHCI driver. The settings are Enabled and **Disabled**.

#### Port 60/64 Emulation

Select Enabled for I/O port 60h/64h emulation support, which in turn, will provide complete legacy USB keyboard support for the operating systems that do not support legacy USB devices. The options are Disabled and **Enabled**.

#### EHCI1

Select Enabled to enable EHCI (Enhanced Host Controller Interface) support on USB 2.0 connector #1 (-at least one USB 2.0 connector should be enabled for EHCI support.) The options are Disabled and **Enabled**.

#### EHCI2

Select Enabled to enable EHCI (Enhanced Host Controller Interface) support on USB 2.0 connector #2 (-at least one USB 2.0 connector should be enabled for EHCI support.) The options are Disabled and **Enabled**.



## ►SATA Configuration

When this submenu is selected, AMI BIOS automatically detects the presence of the SATA devices that are supported by the Intel PCH chip and displays the following items:

### SATA Controller

This item enables or disables the onboard SATA controller supported by the Intel PCH chip. The options are **Enabled** and **Disabled**.

### Configure SATA as

Select IDE to configure a SATA drive specified by the user as an IDE drive. Select AHCI to configure a SATA drive specified by the user as an AHCI drive. Select RAID to configure a SATA drive specified by the user as a RAID drive. The options are IDE, **AHCI**, and **RAID**.

***\*If the item above "Configure SATA as" is set to AHCI, the following items will display:***

#### Support Aggressive Link Power Management

When this item is set to Enabled, the SATA AHCI controller manages the power usage of the SATA link. The controller will put the link to a low power state when the I/O is inactive for an extended period of time, and the power state will return to normal when the I/O becomes active. The options are **Enabled** and **Disabled**.

#### SATA Port 0~ Port 5

This item displays the information detected on the installed SATA drive on the particular SATA port.

- Model number of drive and capacity
- Software Preserve Support

#### Port 0~ Port 5

Select Enabled to enable a SATA port specified by the user. The options are **Disabled** and **Enabled**.

#### Port 0 ~ Port 5 Hot Plug

Select Enabled to enable hot-plugging support for a port specified by the user, which will allow the user to replace a SATA disk drive installed on this port without shutting down the system. The options are **Enabled** and **Disabled**.

#### Port 0 ~ Port 5 Spin Up Device

On an edge detect from 0 to 1, set this item to allow the PCH to initialize the device. The options are **Enabled** and **Disabled**.

#### Port 0 ~ Port 5 SATA Device Type

Use this item to specify if the SATA port specified by the user should be connected to a Solid State drive or a Hard Disk Drive. The options are **Hard Disk Drive** and **Solid State Drive**.

***\*If the item above "Configure SATA as" is set to IDE, the following items will display:***

#### Serial ATA Port 0~ Port 5

This item indicates that a SATA port specified by the user is not installed or not present.

#### Port 0 ~ Port 5 SATA Device Type (Available when a SATA port is detected)

Use this item to specify if the SATA port specified by the user should be connected to a Solid State drive or a Hard Disk Drive. The options are **Hard Disk Drive** and **Solid State Drive**.

***\*If the item above "Configure SATA as" is set to RAID, the following items will display:***

#### Support Aggressive Link Power Management

When this item is set to Enabled, the SATA AHCI controller manages the power usage of the SATA link. The controller will put the link to a low power state when the I/O is inactive for an extended period of time, and the power state will return to normal when the I/O becomes active. The options are **Enabled** and **Disabled**.

#### SATA RAID Option ROM/UEFI Driver

Select EFI to load the EFI driver for system boot. Select Legacy to load a legacy driver for system boot. The options are **Disabled**, **EFI**, and **Legacy**.

#### SATA/sSATA RAID Boot Select

Select SATA Controller to boot the system from a SATA RAID device. Select sSATA Controller to boot the system from a S-SATA RAID device. Select Both to boot the system either from a SATA RAID device or from an sSATA RAID device. Please note that the option-Both is not supported by the Windows Server 2012/R2 OS. The options are **Both**, **SATA Controller**, and **sSATA Controller**.

#### Serial ATA Port 0~ Port 5

This item displays the information detected on the installed SATA drives on the particular SATA port.

- Model number of drive and capacity

- Software Preserve Support

#### Port 0~ Port 5

Select Enabled to enable a SATA port specified by the user. The options are Disabled and Enabled.

#### Port 0 ~ Port 5 Hot Plug

Select Enabled to enable hot-plugging support for a port specified by the user, which will allow the user to replace a SATA disk drive installed on this port without shutting down the system. The options are Enabled and **Disabled**.

#### Port 0 ~ Port 5 Spin Up Device

On an edge detect from 0 to 1, set this item to allow the PCH to start a COMRESET initialization to the device. The options are Enabled and **Disabled**.

#### Port 0 ~ Port 5 SATA Device Type

Use this item to specify if the SATA port specified by the user should be connected to a Solid State drive or a Hard Disk Drive. The options are **Hard Disk Drive** and Solid State Drive.

### ►sSATA Configuration

When this submenu is selected, AMI BIOS automatically detects the presence of the SATA devices that are supported by the PCH-sSATA controller and displays the following items:

#### sSATA Controller

This item enables or disables the onboard SATA controller supported by the Intel PCH-sSATA controller. The options are **Enabled** and Disabled.

#### Configure sSATA as

Select IDE to configure an sSATA drive specified by the user as an IDE drive. Select AHCI to configure an sSATA drive specified by the user as an AHCI drive. Select RAID to configure an sSATA drive specified by the user as a RAID drive. The options are IDE, **AHCI**, and RAID.

***\*If the item above "Configure sSATA as" is set to AHCI, the following items will display:***

#### Support Aggressive Link Power Management

When this item is set to Enabled, the SATA AHCI controller manages the power usage of the SATA link. The controller will put the link to a low power state when the I/O is inactive for an extended period of time, and the power state will return to normal when the I/O becomes active. The options are **Enabled** and Disabled.

#### sSATA Port 0~ Port 3

This item displays the information detected on the installed on the sSATA port. specified by the user.

- Model number of drive and capacity
- Software Preserve Support

#### sSATA Port 0~ Port 3

Select Enabled to enable an sSATA port specified by the user. The options are Disabled and Enabled.

#### sSATA Port 0 ~ Port 3 Hot Plug

Select Enabled to enable hot-plugging support for a port specified by the user, which will allow the user to replace a sSATA disk drive installed on this port without shutting down the system. The options are **Enabled** and Disabled.

#### sSATA Port 0 ~ Port 3 Spin Up Device

On an edge detect from 0 to 1, set this item to allow the PCH to start a COMRESET initialization to the device. The options are Enabled and **Disabled**.

#### Port 0 ~ Port 3 sSATA Device Type

Use this item to specify if the sSATA port specified by the user should be connected to a Solid State drive or a Hard Disk Drive. The options are **Hard Disk Drive** and Solid State Drive.

***\*If the item above "Configure sSATA as" is set to IDE, the following items will display:***

#### sSATA Port 0~ Port 3

This item indicates that an sSATA port specified by the user is not installed or not detected.

#### Port 0 ~ Port 3 sSATA Device Type (Available when a SATA port is detected)

Use this item to specify if the sSATA port specified by the user should be connected to a Solid State drive or a Hard Disk Drive. The options are **Hard Disk Drive** and Solid State Drive.

*\*If the item above "Configure sSATA as" is set to RAID, the following items will display:*

#### Support Aggressive Link Power Management

When this item is set to Enabled, the SATA AHCI controller manages the power usage of the SATA link. The controller will put the link to a low power state when the I/O is inactive for an extended period of time, and the power state will return to normal when the I/O becomes active. The options are **Enabled** and Disabled.

#### sSATA RAID Option ROM/UEFI Driver

Select EFI to load the EFI driver for system boot. Select Legacy to load a legacy driver for system boot. The options are Disabled, EFI, and **Legacy**.

#### SATA/sSATA RAID Boot Select

Select SATA Controller to boot the system from a SATA RAID device. Select sSATA Controller to boot the system from a S-SATA RAID device. Select Both to boot the system either from a SATA RAID device or from an sSATA RAID device. Please note that the option-Both is not supported by the Windows Server 2012/R2 OS. The options are Both, SATA Controller, and **sSATA Controller**.

#### sSATA Port 0~ Port 3

This item displays the information detected on the installed sSATA drives on the particular sSATA port.

- Model number of drive and capacity
- Software Preserve Support

#### sSATA Port 0~ Port 3

Select Enabled to enable an sSATA port specified by the user. The options are Disabled and Enabled.

#### sSATA Port 0 ~ Port 3 Hot Plug

This feature designates this port for hot plugging. Set this item to Enabled for hot-plugging support, which will allow the user to replace an sSATA drive without shutting down the system. The options are Enabled and **Disabled**.

#### sSATA Port 0 ~ Port 3 Spin Up Device

On an edge detect from 0 to 1, set this item to allow the PCH to start a COMRESET initialization to the device. The options are Enabled and **Disabled**.

#### Port 0 ~ Port 3 sSATA Device Type

Use this item to specify if the sSATA port specified by the user should be connected to a Solid State drive or a Hard Disk Drive. The options are **Hard Disk Drive** and Solid State Drive.

### ► Server ME (Management Engine) Configuration

This feature displays the following system ME configuration settings.

- General ME Configuration
- Operational Firmware Version
- Recovery Firmware Version
- ME Firmware Features
- ME Firmware Status #1
- ME Firmware Status #2
  - Current State
  - Error Code

### ► PCIe/PCI/PnP Configuration

The following PCI information will be displayed:

- PCI Bus Driver Version

#### PCI Devices Common Settings:

##### PCI PERR/SERR Support

Select Enabled for the system to log an error event when a PERR (PCI/PCI-E Parity Error) or a SERR (System Error) occurs. The options are Enabled and **Disabled**.

##### SERR# Generation

Select Enabled to allow a PCI device to generate an SERR (System Error) number for a PCI bus error event. The options are Enabled and **Disabled**.

##### Above 4G Decoding (Available if the system supports 64-bit PCI decoding)

Select Enabled to decode a PCI device that supports 64-bit in the space above 4G Address. The options are Enabled and **Disabled**.

**SR-IOV (Available if the system supports Single-Root Virtualization)**

Select Enabled for Single-Root IO Virtualization support. The options are Enabled and **Disabled**.

**Maximum Payload**

Select Auto for the system BIOS to automatically set the maximum payload value for a PCI-E device to enhance system performance. The options are **Auto**, 128 Bytes, and 256 Bytes.

**Maximum Read Request**

Select Auto for the system BIOS to automatically set the maximum size for a read request for a PCI-E device to enhance system performance. The options are **Auto**, 128 Bytes, 256 Bytes, 512 Bytes, 1024 Bytes, 2048 Bytes, and 4096 Bytes.

**ASPM Support**

Use this item to set the Active State Power Management (ASPM) level for a PCI-E device. Select Auto for the system BIOS to automatically set the ASPM level based on the system configuration. Select Disabled to disable ASPM support. The options are Disabled, and **Auto**.

**Warning:** Enabling ASPM support may cause some PCI-E devices to fail!

**MMIOHBase**

Use this item to select the base memory size according to memory-address mapping for the IO hub. The base memory size must be between 4032G to 4078G. The options are **56T**, 48T, 24T, 512G, and 256G.

**MMIO High Size**

Use this item to select the high memory size according to memory-address mapping for the IO hub. The options are **256G**, 128G, 512G, and 1024G.

**CPU1 SLOT4 PCI-E x8 (OPROM)/CPU1 SLOT54 PCI-E x8 (OPROM)/CPU1 SLOT6 PCI-E x8 (OPROM)/CPU2 SLOT7 PCI-E x8 (OPROM)**

Select Enabled to enable Option ROM support to boot the computer using a device installed on the slot specified by the user. The options are Disabled, **Legacy** and EFI.

**Onboard LAN Option ROM Type**

Select Enabled to enable Option ROM support to boot the computer using a device installed on the slot specified by the user. The options are **Legacy** and EFI.

**Onboard LAN1 Option ROM/Onboard LAN2 Option ROM**

Use this option to select the type of device installed in LAN Port1 or LAN Port2 used for system boot. The default setting for LAN1 Option ROM is **PXE**, and the default setting for LAN2 Option ROM is **Disabled**.

**Onboard NVMe1 Option ROM/Onboard NVMe2 Option ROM**

Use this option to select the type of device installed in NVMe Connector 1 or NVMe Connector 2 used for system boot. The options are Disabled and **EFI**.

**Onboard Video OPROM**

This feature controls how the system executes UEFI (Unified Extensible Firmware Interface) and Legacy Video OPROM. Select Legacy to boot the system using a legacy video device installed on the motherboard. The options are Disabled, **Legacy** and EFI.

**VGA Priority**

Use this item to select the graphics device to be used as the primary video display for system boot. The options are **Onboard** and Offboard.

**►Super IO Configuration****Super IO Chip AST2400****►Serial Port 1 Configuration/Serial Port 2 Configuration****Serial Port 1/Serial Port 2**

Select Enabled to enable the onboard serial port specified by the user. The options are **Enabled** and Disabled.

**Device Settings**

This item displays the base I/O port address and the Interrupt Request address of a serial port specified by the user.

**Change Port 1 Settings/Change Port 2 Settings**

This feature specifies the base I/O port address and the Interrupt Request address of Serial Port 1 or Serial Port 2. Select **Auto** for the BIOS to automatically assign the base I/O and IRQ address to a serial port specified.

The options for Serial Port 1 are **Auto**, (IO=3F8h; IRQ=4), (IO=3F8h; IRQ=3, 4, 5, 6, 7, 9, 10, 11, 12), (IO=2F8h; IRQ=3, 4, 5, 6, 7, 9, 10, 11, 12); (IO=3E8h; IRQ=3, 4, 5, 6, 7, 9, 10, 11, 12), and (IO=2E8h; IRQ=3, 4, 5, 6, 7, 9, 10, 11, 12).

The options for Serial Port 2 are **Auto**, (IO=3F8h; IRQ=4), (IO=3F8h; IRQ=3, 4, 5, 6, 7, 9, 10, 11, 12), (IO=2F8h; IRQ=3, 4, 5, 6, 7, 9, 10, 11, 12); (IO=3E8h; IRQ=3, 4, 5, 6, 7, 9, 10, 11, 12), and (IO=2E8h; IRQ=3, 4, 5, 6, 7, 9, 10, 11, 12).

**Device Mode**

Use this feature to configure SUART clock source settings. The options are **24MHz/13** and 24MHz.

**Serial Port 2 Attribute**

Select SOL to use COM Port 2 as a Serial\_Over\_LAN (SOL) port for console redirection. The options are COM and **SOL**.

**►Serial Port Console Redirection****COM 1 Console Redirection****COM1 Console Redirection**

Select Enabled to enable COM Port 1 for Console Redirection, which will allow a client machine to be connected to a host machine at a remote site for networking. The options are Enabled and **Disabled**.

*\*If the item above is set to Enabled, the following items will become available:*

**►COM1 Console Redirection Settings****Terminal Type**

This feature allows the user to select the target terminal emulation type for Console Redirection. Select VT100 to use the ASCII Character set. Select VT100+ to add color and function key support. Select ANSI to use the Extended ASCII Character Set. Select VT-UTF8 to use UTF8 encoding to map Unicode characters into one or more bytes. The options are ANSI, VT100, **VT100+**, and VT-UTF8.

**Bits Per second**

Use this item to set the transmission speed for a serial port used in Console Redirection. Make sure that the same speed is used in the host computer and the client computer. A lower transmission speed may be required for long and busy lines. The options are 9600, 19200, 38400, 57600 and **115200** (bits per second).

**Data Bits**

Use this feature to set the data transmission size for Console Redirection. The options are 7 (Bits) and **8 (Bits)**.

**Parity**

A parity bit can be sent along with regular data bits to detect data transmission errors. Select Even if the parity bit is set to 0, and the number of 1's in data bits is even. Select Odd if the parity bit is set to 0, and the number of 1's in data bits

is odd. Select None if you do not want to send a parity bit with your data bits in transmission. Select Mark to add a mark as a parity bit to be sent along with the data bits. Select Space to add a Space as a parity bit to be sent with your data bits. The options are **None**, Even, Odd, Mark and Space.

**Stop Bits**

A stop bit indicates the end of a serial data packet. Select 1 Stop Bit for standard serial data communication. Select 2 Stop Bits if slower devices are used. The options are **1** and 2.

**Flow Control**

Use this item to set the flow control for Console Redirection to prevent data loss caused by buffer overflow. Send a "Stop" signal to stop sending data when the receiving buffer is full. Send a "Start" signal to start sending data when the receiving buffer is empty. The options are **None** and Hardware RTS/CTS.

**VT-UTF8 Combo Key Support**

Select Enabled to enable VT-UTF8 Combination Key support for ANSI/VT100 terminals. The options are **Enabled** and Disabled.

**Recorder Mode**

Select Enabled to capture the data displayed on a terminal and send it as text messages to a remote server. The options are **Disabled** and Enabled.

**Resolution 100x31**

Select Enabled for extended-terminal resolution support. The options are Disabled and **Enabled**.

**Legacy OS Redirection Resolution**

Use this item to select the number of rows and columns used in Console Redirection for legacy OS support. The options are 80x24 and **80x25**.

**Putty KeyPad**

This feature selects Function Keys and KeyPad settings for Putty, which is a terminal emulator designed for the Windows OS. The options are **VT100**, LINUX, XTERMR6, SCD, ESCN, and VT400.

**Redirection After BIOS Post**

Use this feature to enable or disable legacy Console Redirection after BIOS POST. When the option-Bootloader is selected, legacy Console Redirection is disabled before booting the OS. When the option- Always Enable is selected, legacy Console Redirection remains enabled upon OS bootup. The options are **Always Enable** and Bootloader.

**SOL/COM2****Console Redirection**

Select Enabled to use the SOL port for Console Redirection. The options are **Enabled** and Disabled.

*\*If the item above set to Enabled, the following items will become available for user's configuration:*

**► SOL/COM2 Console Redirection Settings**

Use this feature to specify how the host computer will exchange data with the client computer, which is the remote computer used by the user.

**Terminal Type**

Use this feature to select the target terminal emulation type for Console Redirection. Select VT100 to use the ASCII Character set. Select VT100+ to add color and function key support. Select ANSI to use the Extended ASCII Character Set. Select VT-UTF8 to use UTF8 encoding to map Unicode characters into one or more bytes. The options are ANSI, VT100, **VT100+**, and VT-UTF8.

**Bits Per second**

Use this feature to set the transmission speed for a serial port used in Console Redirection. Make sure that the same speed is used in the host computer and the client computer. A lower transmission speed may be required for long and busy lines. The options are 9600, 19200, 38400, 57600 and **115200** (bits per second).

**Data Bits**

Use this feature to set the data transmission size for Console Redirection. The options are 7 (Bits) and **8 (Bits)**.

**Parity**

A parity bit can be sent along with regular data bits to detect data transmission errors. Select Even if the parity bit is set to 0, and the number of 1's in data bits is even. Select Odd if the parity bit is set to 0, and the number of 1's in data bits is odd. Select None if you do not want to send a parity bit with your data bits in transmission. Select Mark to add a mark as a parity bit to be sent along with the data bits. Select Space to add a Space as a parity bit to be sent with your data bits. The options are **None**, Even, Odd, Mark and Space.

**Stop Bits**

A stop bit indicates the end of a serial data packet. Select 1 Stop Bit for standard serial data communication. Select 2 Stop Bits if slower devices are used. The options are **1** and 2.

**Flow Control**

Use this feature to set the flow control for Console Redirection to prevent data loss caused by buffer overflow. Send a "Stop" signal to stop sending data when the receiving buffer is full. Send a "Start" signal to start data-sending when the receiving buffer is empty. The options are **None** and Hardware RTS/CTS.

**VT-UTF8 Combo Key Support**

Select Enabled to enable VT-UTF8 Combination Key support for ANSI/VT100 terminals. The options are **Enabled** and Disabled.

**Recorder Mode**

Select Enabled to capture the data displayed on a terminal and send it as text messages to a remote server. The options are **Disabled** and Enabled.

**Resolution 100x31**

Select Enabled for extended-terminal resolution support. The options are Disabled and **Enabled**.

**Legacy OS Redirection Resolution**

Use this feature to select the number of rows and columns used in Console Redirection for legacy OS support. The options are 80x24 and **80x25**.

**Putty KeyPad**

This feature selects Function Keys and KeyPad settings for Putty, which is a terminal emulator designed for the Windows OS. The options are **VT100**, LINUX, XTERMR6, SCD, ESCN, and VT400.

**Redirection After BIOS Post**

Use this feature to enable or disable legacy Console Redirection after BIOS POST. When this feature is set to Bootloader, legacy Console Redirection is disabled before booting the OS. When this feature is set to Always Enable, legacy Console Redirection remains enabled upon OS boot. The options are **Always Enable** and Bootloader.

**► Legacy Console Redirection Settings****Legacy Serial Redirection Port**

Use this item to select a COM port to be used for Console Redirection to display Legacy OS and Legacy OPROM messages. The options are **COM1** and SOL/COM2.

### Serial Port for Out-of-Band Management/Windows Emergency Management Services (EMS)

The submenu allows the user to configure Console Redirection settings to support Out-of-Band Serial Port management.

#### EMS Console Redirection

Select Enabled to use a COM port selected by the user for EMS Console Redirection. The options are Enabled and **Disabled**.

*\*If the item above set to Enabled, the following items will become available for user's configuration:*

### ►EMS Console Redirection Settings (Available when EMS Console Redirection is enabled)

Use this feature to specify how the host computer will exchange data with the client computer, which is the remote computer used by the user.

#### Out-of-Band Management Port

The feature selects a serial port in a client server to be used by the Windows Emergency Management Services (EMS) to communicate with a remote host server. The options are **COM1** and COM2/SOL.

#### Terminal Type

Use this feature to select the target terminal emulation type for Console Redirection. Select VT100 to use the ASCII character set. Select VT100+ to add color and function key support. Select ANSI to use the extended ASCII character set. Select VT-UTF8 to use UTF8 encoding to map Unicode characters into one or more bytes. The options are ANSI, VT100, VT100+, and **VT-UTF8**.

#### Bits Per Second

This item sets the transmission speed for a serial port used in Console Redirection. Make sure that the same speed is used in both host computer and the client computer. A lower transmission speed may be required for long and busy lines. The options are 9600, 19200, 57600, and **115200** (bits per second).

#### Flow Control

Use this item to set the flow control for Console Redirection to prevent data loss caused by buffer overflow. Send a "Stop" signal to stop data-sending when the receiving buffer is full. Send a "Start" signal to start data-sending when the receiving buffer is empty. The options are **None**, Hardware RTS/CTS, and Software Xon/Xoff.

The setting for each these features is displayed:

### Data Bits, Parity, Stop Bits

### ►ACPI Settings

#### WHEA Support

Select Enabled to support the Windows Hardware Error Architecture (WHEA) platform and provide a common infrastructure for the system to handle hardware errors within the Windows OS environment to reduce system crashes and to enhance system recovery and health monitoring. The options are **Enabled** and Disabled.

#### High Precision Timer

Select Enabled to activate the High Precision Event Timer (HPET) that produces periodic interrupts at a much higher frequency than a Real-time Clock (RTC) does in synchronizing multimedia streams, providing smooth playback and reducing the dependency on other timestamp calculation devices, such as an x86 RDTSC Instruction embedded in the CPU. The High Performance Event Timer is used to replace the 8254 Programmable Interval Timer. The options are **Enabled** and Disabled.

#### NUMA Support (Available when the OS supports this feature)

Select Enabled to enable Non-Uniform Memory Access support to enhance system performance. The options are **Enabled** and Disabled.

#### PCI AER Support

Select Enabled to support Advanced Error Reporting for onboard PCI devices. The options are **Disabled** and Enabled.

### ►Trusted Computing (Available when a TPM device is installed and detected by the BIOS)

#### Configuration

#### Security Device Support

If this feature and the TPM jumper on the motherboard are both set to Enabled, onboard security devices will be enabled for TPM support to enhance data integrity and network security. Please reboot the system for a change on this setting to take effect. The options are Enabled and **Disabled**.

#### TPM State

Select Enabled to use TPM (Trusted Platform Module) settings to enhance system data security. Please reboot your system for any change on the TPM state to take effect. The options are Disabled and **Enabled**.

### Pending Operation

Use this item to schedule a TPM-related operation to be performed by a security device for system data integrity. Your system will reboot to carry out a pending TPM operation. The options are **None**, Enable Take Ownership, Disable Take Ownership, and TPM Clear.

**Note:** Your system will reboot to carry out a pending TPM operation.

### Current Status Information

This item displays the status of the TPM support on this motherboard:

- TPM Enabled Status
- TPM Active Status
- TPM Owner Status

### TXT Support

Select Enabled to enable TXT (Trusted Execution Technology) settings to improve data and network security. The options are **Disabled** and Enabled.

### ► iSCSI Configuration

This item displays iSCSI configuration information:

#### iSCSI Initiator Name

This item displays the name of the iSCSI Initiator, which is a unique name used in the world. The name must use the IQN format. The following actions can also be performed:

- Add an Attempt
- Delete Attempts
- Change Attempt Order

## 7-4 Event Logs

Use this feature to configure Event Log settings.

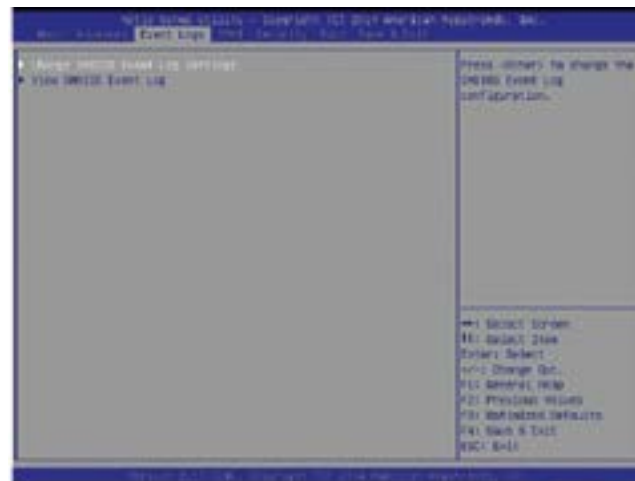

### ► Change SMBIOS Event Log Settings

This feature allows the user to configure SMBIOS Event settings.

#### Enabling/Disabling Options

##### SMBIOS Event Log

Select Enabled to enable SMBIOS (System Management BIOS) Event Logging during system boot. The options are **Enabled** and Disabled.

##### Runtime Error Logging Support

Select Enable to support Runtime Error Logging. The options are **Enable** and Disabled. If this item is set to Enable, the following item will be available for configuration:

##### Memory Corrected Error Enabling (Available when the item above-Runtime Error Logging Support is set to Enable)

Select Enable for the BIOS to correct a memory error if it is correctable. The options are Enable and **Disable**.

##### Memory Correctable Error Threshold

Use this item to enter the threshold value for correctable memory errors. The default setting is **10**.

##### PCI-Ex (PCI-Express) Error Enable

Select Yes for the BIOS to correct errors occurred in the PCI-E slots. The options are Yes and **No**.



## Erasing Settings

### Erase Event Log

Select Enabled to erase all error events in the SMBIOS (System Management BIOS) log before an event logging is initialized at bootup. The options are **No**, Yes, Next Reset and Yes, Every Reset.

### When Log is Full

Select Erase Immediately to immediately erase all errors in the SMBIOS event log when the event log is full. Select Do Nothing for the system to do nothing when the SMBIOS event log is full. The options are **Do Nothing** and Erase Immediately.

### SMBIOS Event Log Standard Settings

#### Log System Boot Event

Select Enabled to log system boot events. The options are **Disabled** and Enabled.

#### MECI (Multiple Event Count Increment)

Enter the increment value for the multiple event counter. Enter a number between 1 to 255. The default setting is **1**.

#### METW (Multiple Event Count Time Window)

This item is used to determine how long (in minutes) should the multiple event counter wait before generating a new event log. Enter a number between 0 to 99. The default setting is **60**.

**Note:** Please reboot the system for the changes to take effect.

### ►View SMBIOS Event Log

This item allows the user to view the event in the SMBIOS event log. Select this item and press <Enter> to view the status of an event in the log. The following categories are displayed:

- Date
- Time
- Error Code
- Severity

## 7-5 IPMI

Use this feature to configure Intelligent Platform Management Interface (IPMI) settings.



### IPMI Firmware Revision

This item indicates the IPMI firmware revision used in your system.

### IPMI Status

This item indicates the status of the IPMI firmware installed in your system.

### ►System Event Log

#### Enabling/Disabling Options

#### SEL Components

Select Enabled to enable all system event logging support at bootup. The options are **Enabled** and Disabled.

#### Erasing Settings

#### Erase SEL

Select Yes, On next reset to erase all system event logs upon next system reboot. Select Yes, On every reset to erase all system event logs upon each system reboot. Select No to keep all system event logs after each system reboot. The options are **No**, Yes, On next reset, and Yes, On every reset.

**When SEL is Full**

This feature allows the user to determine what the BIOS should do when the system event log is full. Select Erase Immediately to erase all events in the log when the system event log is full. The options are **Do Nothing** and Erase Immediately.

**Note:** Reboot the system for the changes to take effect.

**Log EFI Status Codes**

Select EFI (Extensible Firmware Interface) Status Codes to log EFI status codes. Select Error Codes to log EFI error codes. Select Progress Code to log the EFI progress code. Select both to log both EFI error codes and progress codes. The options are Disabled, Both, **Error code** and Progress code.

**Note:** Reboot the system for the changes to take effect.

**►BMC Network Configuration**

The following items will be displayed:

**IPMI LAN Selection**

Use this feature to select the type of the IPMI LAN. The default setting is **Failover**.

**IPMI Network Link Status**

This item indicates the status of the IPMI Network Link. The default setting is **Dedicated LAN**.

**Update IPMI LAN Configuration**

Select Yes for the system BIOS to automatically reset the following IPMI settings at next system boot. The options are Yes and **No**.

**Configuration Address Source**

Use this item to select the IP address source for this computer. If Static is selected, you will need to know the IP address of this computer and enter it to the system manually in the field. If DHCP is selected, AMI BIOS will search for a DHCP (Dynamic Host Configuration Protocol) server attached to the network and request the next available IP address for this computer. The options are **DHCP** Unspecified, and Static.

**Station IP Address**

This item displays the Station IP address for this computer. This should be in decimal and in dotted quad form (i.e., 192.168.10.253).

**Subnet Mask**

This item displays the sub-network that this computer belongs to. The value of each three-digit number is separated by dots and it should not exceed 255.

**Station MAC Address**

This item displays the Station MAC address for this computer. Mac addresses are 6 two-digit hexadecimal numbers.

**Router IP Address**

This item displays the Router IP address for this computer.

## 7-6 Security Settings

This menu allows the user to configure the following security settings for the system.



### Password Check

If this feature is set to Setup, a password is required for a user to enter the BIOS Setup utility. If Always selected, the user will need to enter a password when entering the Setup utility and upon each system boot. The options are **Setup** and **Always**.

### Administrator Password

Use this feature to set the administrator password which is required before entering the BIOS setup utility. The length of the password should be from 3 characters to 20 characters long.

### User Password

Use this feature to set the user password which is required to enter the BIOS setup utility. The length of the password should be from 3 characters to 20 characters long.

## 7-7 Boot Settings

Use this feature to configure Boot Settings:

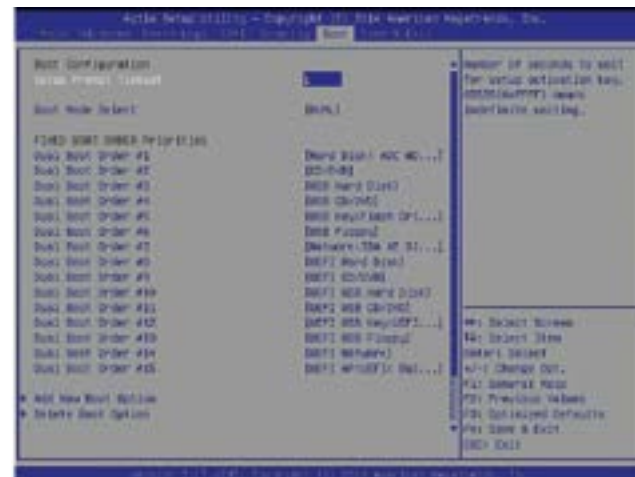

### Setup Prompt Timeout

This feature allows the user to determine how long the system should wait for the setup activation key before it boots up. The default setting is **1 (second)**.

### Boot Mode Select

Use this item to select the type of device to be used for system boot. The options are Legacy, UEFI, and **Dual**.

### Fixed Boot Order Priorities

This option prioritizes the order of bootable devices that the system to boot from. Press <Enter> on each entry from top to bottom to select devices.

- Dual Boot Order #1
- Dual Boot Order #2
- Dual Boot Order #3
- Dual Boot Order #4
- Dual Boot Order #5
- Dual Boot Order #6
- Dual Boot Order #7

- Dual Boot Order #8
- Dual Boot Order #9
- Dual Boot Order #10
- Dual Boot Order #11
- Dual Boot Order #12
- Dual Boot Order #13
- Dual Boot Order #14
- Dual Boot Order #15

► **Add New Boot Option**

Use this item to select a new boot device to add to the boot priority list.

**Add Boot Option**

Select the target boot device to add to the boot priority list.

**Path for Boot Option**

Select the device path (-the file system) for the new boot device to use.

**Create**

After selecting a boot device to add and the path for this new device, choose this feature and click OK to add the new device to the boot priority list.

► **Delete Boot Option**

Use this item to select a boot device to delete from the boot priority list.

**Delete Boot Option**

Select the target boot device to delete.

► **Delete Driver Option**

Use this item to select a driver to delete from the boot priority list.

**Delete Driver Option**

Select the target driver to delete.

► **Hard Disk Driver BBS Priorities**

- Legacy Boot Order #1 - Legacy Boot Order #4

► **NETWORK Disk Drive BBS Priorities**

- Legacy Boot Order #1

► **UEFI Application Boot Priorities**

- UEFI Boot Order #1

## 7-8 Save & Exit

Select the Save & Exit tab from the BIOS setup screen to configure the settings below.



### Discard Changes and Exit

Select this option to quit the BIOS setup without making any permanent changes to the system configuration, and reboot the computer. Select Discard Changes and Exit from the Exit menu and press <Enter>.

### Save Changes and Reset

After making system configuration changes, select this option to leave the BIOS setup utility and reboot the computer for the new system configuration parameters to take effect. Select Save Changes and Exit from the Exit menu and press <Enter>.

### Save Options

#### Save Changes

After making system configuration changes, select this option to save all changes made. This will not reset (reboot) the system.

#### Discard Changes

Select this option and press <Enter> to discard all the changes you've made and return to the AMI BIOS Utility Program.

#### Restore Optimized Defaults

To set this feature, select Restore Optimized Defaults from the Exit menu and press <Enter>. These are manufacture default settings designed for maximum system performance but not for maximum stability.

### Save As User Defaults

To set this feature, select Save as User Defaults from the Exit menu and press <Enter>. This enables the user to save any changes to the BIOS setup for future use.

### Restore User Defaults

To set this feature, select Restore User Defaults from the Exit menu and press <Enter>. Use this feature to retrieve user-defined settings that were saved previously.

### Boot Override

This feature allows the user to override the Boot priorities sequence in the Boot menu, and immediately boot the system with another device specified by the user. This is a one-time override.

## Notes

## Appendix A

### BIOS Error Beep Codes

During the POST (Power-On Self-Test) routines, which are performed upon each system boot, errors may occur.

**Non-fatal errors** are those which, in most cases, allow the system to continue to boot. These error messages normally appear on the screen.

**Fatal errors** will not allow the system to continue with bootup. If a fatal error occurs, you should consult with your system manufacturer for possible repairs.

These fatal errors are usually communicated through a series of audible beeps. The numbers on the fatal error list correspond to the number of beeps for the corresponding error.

BIOS Error Beep Codes		
Beep Code/LED	Error Message	Description
1 beep	Refresh	Ready to boot
5 short beeps + 1 long beep	Memory error	No memory detected in the system
5 beeps	No con-in or con-out devices	Con-in includes USB or PS/2 keyboard, PCI or serial console redirection, and IPMI KVM or SOL.  Con-out includes the video controller, PCI or serial console redirection, and IPMI SOL.
1 beep per device	Refresh	1 beep for each USB device detected
<b>IPMI Error Codes</b>		
1 Continuous beep	System OH	System overheat

# Notes



# Appendix B

## System Specifications

### Processors

Dual Intel® Xeon® E5-2600 v3 Series v3/v4 processors in R3 LGA 2011 sockets

**Note:** Please refer to our web site for a complete listing of supported processors.

### Chipset

Intel PCH C612

### Memory Capacity

Eight DIMM sockets that can support up to 1 TB of LRDIMM (Load Reduced DIMM) or up to 512 GB of ECC RDIMM (Registered DIMM) DDR4-2400/2133/1866/1600 memory

**Note:** See the memory section in Chapter 5 for details.

### SATA

Intel on-chip controller for six SATA 3.0 ports, RAID 0, 1 5 and 10 supported

### SATA Drive Bays

Four hot-swap drive bays to house four SATA hard drives

### Expansion Slots

Riser card for one PCI-E 3.0 x8 add-on card

### Serverboard

X10DRD-LTP

Dimensions: 13.05 x 10.5 in (331.5 x 266.7 mm)

### Chassis

SC815TQ-600CB/SC815TQ-R500CB

Form Factor: 1U rackmount

Dimensions: (WxHxD) 17.2 x 1.7 x 25.6 in. (437 x 43 x 650 mm)

**Weight**

6018R-TDTP: 36 lbs. (16.33 kg.)

6018R-TDTPR: 38 lbs. (17.24 kg.)

**System Cooling**

Five 4-cm heavy-duty counter-rotating fans

**System Input Requirements**

6018R-TDTP (single module)

AC Input Voltage: 100-240V AC auto-range

Rated Input Current: 7.5A (max)

Rated Input Frequency: 50 to 60 Hz

6018R-TDTPR (dual/redundant modules)

AC Input Voltage: 100-240V AC auto-range

Rated Input Current: 6.2-2.6A (max)

Rated Input Frequency: 50 to 60 Hz

**Power Supply**

6018R-TDTP (single module)

Rated Output Power: 600W (Part# PWS-605P-1H)

Rated Output Voltages: +3.3V (15A), +5V (18A), +12V (49A), -12V (0.5A), +5Vsb (3A)

6018R-TDTPR (dual/redundant modules)

Rated Output Power: 500W (Part# PWS-504P-1R)

Rated Output Voltages: +3.3V (12A), +5V (25A), +12V (42A), -12V (0.6A), +5Vsb (3A)

**Operating Environment**

Operating Temperature: 5° to 40° C (41° to 104° F)

Non-operating Temperature: -40° to 70° C (-40° to 158° F)

Operating Relative Humidity: 8% to 90% (non-condensing)

Non-operating Relative Humidity: 5% to 95% (non-condensing)

**Regulatory Compliance**

Electromagnetic Emissions:

FCC Class A, EN 55022 Class A, EN 61000-3-2/-3-3, CISPR 22 Class A

Electromagnetic Immunity:

EN 55024/CISPR 24, (EN 61000-4-2, EN 61000-4-3, EN 61000-4-4, EN 61000-4-5, EN 61000-4-6, EN 61000-4-8, EN 61000-4-11)

Safety:

EN 60950/IEC 60950-Compliant, UL Listed (USA), CUL Listed (Canada), TUV Certified (Germany), CE Marking (Europe)

California Best Management Practices Regulations for Perchlorate Materials: This Perchlorate warning applies only to products containing CR (Manganese Dioxide) Lithium coin cells. "Perchlorate Material-special handling may apply. See [www.dtsc.ca.gov/hazardouswaste/perchlorate](http://www.dtsc.ca.gov/hazardouswaste/perchlorate)"

Disclaimer (continued from front)

The products sold by Supermicro are not intended for and will not be used in life support systems, medical equipment, nuclear facilities or systems, aircraft, aircraft devices, aircraft/emergency communication devices or other critical systems whose failure to perform be reasonably expected to result in significant injury or loss of life or catastrophic property damage. Accordingly, Supermicro disclaims any and all liability, and should buyer use or sell such products for use in such ultra-hazardous applications, it does so entirely at its own risk. Furthermore, buyer agrees to fully indemnify, defend and hold Supermicro harmless for and against any and all claims, demands, actions, litigation, and proceedings of any kind arising out of or related to such ultra-hazardous use or sale.

## Notes