

INSTRUCTION MANUAL
TYPE 316B, 10 KW
AM BROADCAST TRANSMITTER
S/N 22 -- 740 KC / 640 KC
for
KCBS -- SAN FRANCISCO

Continental  *Electronics*

MANUFACTURING COMPANY

4212 S. Buckner Blvd.

Dallas 27, Texas

If You Didn't Get This From My Site,
Then It Was Stolen From...

www.SteamPoweredRadio.Com

INSTRUCTION MANUAL
TYPE 316B, 10 KW
AM BROADCAST TRANSMITTER
S/N 22 -- 740 KC / 640 KC
for
KCBS -- SAN FRANCISCO

Efficiency = 50.5

Continental  *Electronics*

MANUFACTURING COMPANY

4212 S. BUCKNER BLVD.

DALLAS 27, TEXAS

214-381-7161

If You Didn't Get This From My Site,
Then It Was Stolen From...

www.SteamPoweredRadio.Com

TABLE OF CONTENTS

	<u>Page</u>
SECTION 1. DESCRIPTION	
1-1. Introduction	1-2
1-2. General Description	1-2
1-3. Technical Summary	1-5
1-3. [REDACTED]	[REDACTED]
1-4. Tube Complement	1-6
1-5. R-F Amplifier and Modulator Circuits	1-6
1-6. Protective Circuits	1-11
1-7. Power Supplies	1-13
1-8. Test Metering, Scale Interpretation	1-14
1-9. Power Cutback	1-15
1-10. Conelrad Frequency Changing	1-16
1-11. 50 Cycle Operation	1-18
SECTION 2. INSTALLATION AND OPERATION	
2-1. Unpacking and Assembly	2-2
2-2. External Air Supply	2-4
2-3. Operational Check	2-4
2-4. Operation	2-8
2-5. Tuning	2-8
2-6. Adjustment of Hum Balance Control	2-9
2-7. Use of Overall Feedback	2-9
2-8. Tuning Charts	2-10
2-9. Factory Test Data on Serial No. 22	2-16

TABLE OF CONTENTS (CONTINUED)

	<u>Page</u>
SECTION 3. PREVENTIVE MAINTENANCE	
3-1. Cleaning of Air Filters	3-1
3-2. Cleaning of Vacuum Capacitors and Vacuum Switch	3-1
3-3. Cleaning of Vacuum Tubes	3-1
3-4. Lubrication of Blower Motors	3-2
3-5. Lubrication of Tuning Drives	3-2
3-6. General	3-2
 SECTION 4. TROUBLE-SHOOTING	
4-1. Rectifier Control Unit	4-1
4-2. Amplifier Unit	4-1
 SECTION 5. ILLUSTRATIONS	
1-1. 5/10 KW Broadcast Transmitter Type 315B/316B	1-1
1-2. Screen Modulator-Regulator Circuit, Simplified Schematic	1-10
2-1. Installation Diagram Type 315B/316B Transmitter	2-1
2-2. Location of Controls	2-5
5-1. Amplifier Unit, Front View	5-1
5-2. Amplifier Unit, Left Side	5-2
5-3. Amplifier Unit, Right Side	5-3
5-4. Amplifier Unit, Upper Portion	5-4

TABLE OF CONTENTS (CONTINUED)

		<u>Page</u>
5-5.	Amplifier Unit, Lower Portion	5-5
5-6.	Amplifier Unit, Underside of P-A Shelf	5-6
5-7.	Amplifier Unit, RF Driver Shelf, Top View	5-7
5-8.	Amplifier Unit, Underside of RF Driver Shelf	5-8
5-9.	Amplifier Unit, Modulator Shelf, Top View	5-9
5-10.	Amplifier Unit, Underside of Modulator Shelf	5-10
5-11.	Rectifier-Control Unit, Front View	5-11
5-12.	Rectifier-Control Unit, Upper Portion	5-12
5-13.	Rectifier-Control Unit, Lower Left Side	5-13
5-14.	Rectifier-Control Unit, Lower Right Side	5-14

SECTION 6. ELECTRICAL PARTS LISTS

7428	Rectifier-Control Unit
7429	Exciter-Amplifier Unit
1-(4841B)	30XT Crystal Oscillator

SECTION 7. DRAWINGS

11235-A	Block Diagram, Type 315B 5 KW Transmitter
11234-A	Block Diagram, Type 316B 10 KW Transmitter
19001-E	Rectifier-Control Unit, Schematic Diagram
19002-E	Exciter-Amplifier Unit, Schematic Diagram
4841-B	Type 30XT Crystal Oscillator, Schematic Diagram
19345-B	Modification Diagram for Power Change - 10 KW to 5 KW (Cutback)

TABLE OF CONTENTS (CONTINUED)

- 19030-B Interconnection Diagram for Remote Control
19947-B Control Circuit, Conelrad Frequency Changing
19948-B Contact Connections, Conelrad Frequency Changing

SECTION 8. TUBE DATA

- 4CX5000A Power Tetrode
4-65A Power Tetrode

WARNING

The voltages employed in this equipment are sufficiently high to endanger human life. Use extreme care when operating and servicing the transmitter.

Every reasonable precaution has been observed in the design of this transmitter to safeguard the operating personnel. Series-connected interlock switches disable all high-voltage supplies when any door which exposes dangerous voltages is opened. Do not, under any circumstances, tamper with these switches or incapacitate them.

For added safety, a mechanical grounding switch is associated with each cabinet door. This switch places a positive short circuit on all hazardous circuits within the cabinet when the door is opened.

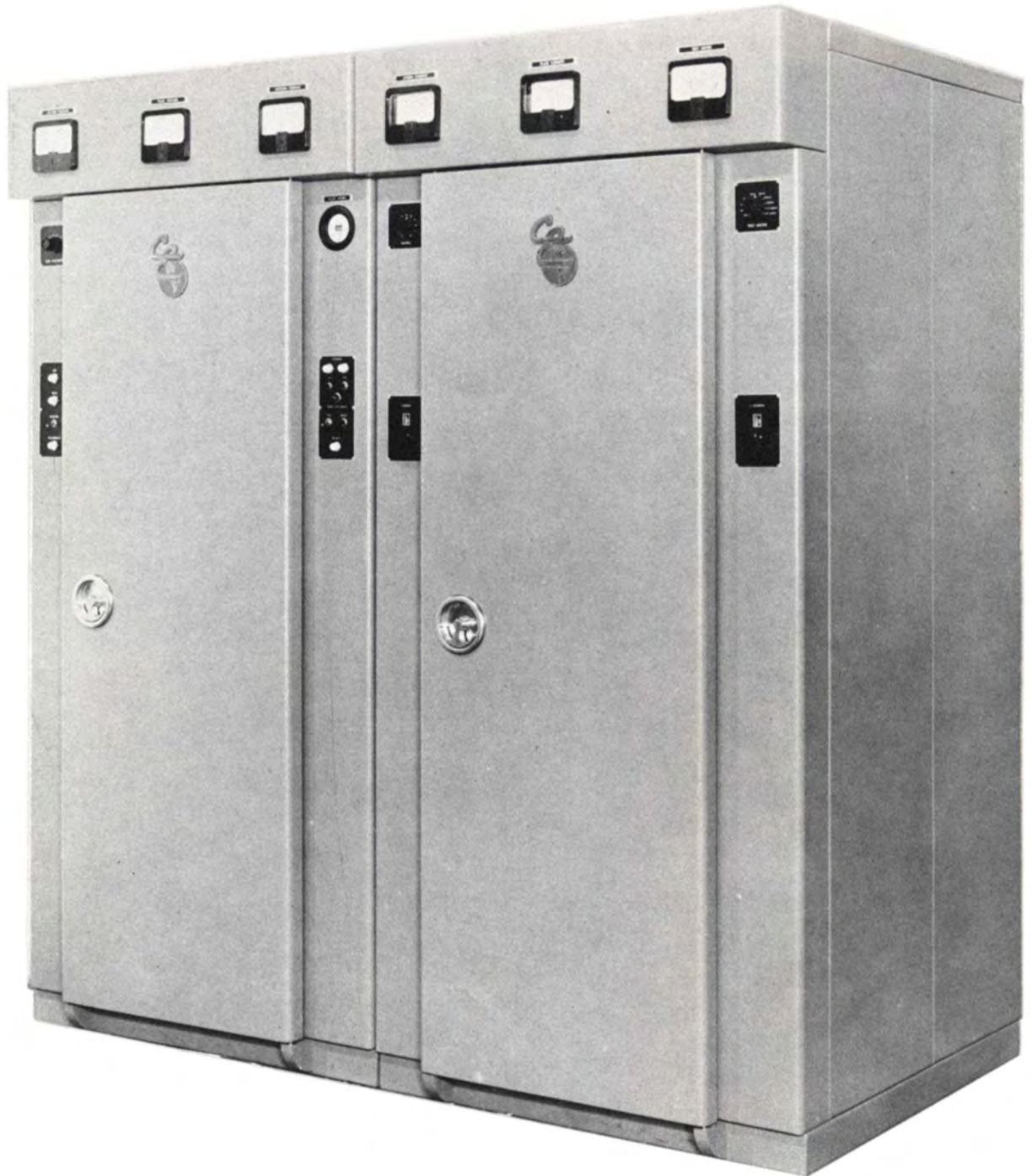

FIGURE 1-1

5/10 KW BROADCAST TRANSMITTER, TYPE 315B/316B

SECTION 1. DESCRIPTION

1-1. Introduction

The Continental Electronics Types 315B and 316B are standard broadcast band AM transmitters with 5,000 watts and 10,000 watts nominal r-f power output, respectively. The two are essentially identical, mechanically and electrically. At any time, the owner of a Type 315B transmitter may increase power to ten kilowatts by adding the necessary tubes and parts, for which space is provided in the equipment.

The circuitry of these transmitters is simple and straightforward. The r-f lineup consists of four stages: the crystal oscillator is followed by an untuned buffer, fixed-tuned driver and final amplifier. Modulation and carrier level regulation are accomplished at the screen grids of the final amplifier, using a direct-coupled cathode-follower system.

Overall r-f feedback is tapped from the output of the transmitter, rectified, and applied to the first audio stage to reduce noise and to improve linearity.

The transmitter is housed in two frameless aluminum cabinets which are designed for excellent shielding, light weight and easy access to components.

1-2. General DescriptionA. Screen Grid Modulation

Screen Grid Modulation, as used in Continental Electronics Standard Broadcast Transmitters, offers a number of features and advantages. Some of these are as follows:

1. Modulator power requirements are greatly reduced. A constant source of r-f excitation is applied to the control grid of a tetrode type tube, while audio modulation is applied to the screen grid. Since r-f output is controlled linearly by screen grid potential, with relatively low values of screen current, an excellent method of modulation is possible and very little power is consumed.
2. Tetrodes are inherently a high gain type of tube. Therefore, very little r-f driving power is required.

3. Since the screen grid is operated at ground potential insofar as r-f signal is concerned, it serves as a shield between the control grid and plate of the tube and thereby eliminates the necessity of neutralization.
4. Since the original modulation power is very low, small audio components may be used. The audio system is entirely of the resistance coupled type, with complete absence of large transformers or chokes. This makes possible a very fine degree of transmitter performance. RMS distortion and distortion due to inter-modulation are very low, because of the absence of iron core components.
5. The audio and modulation system may be designed with full control of phase shift characteristics, making possible the use of overall feedback in the transmitter. The performance of the transmitter is thereby further improved. Overall feedback cannot be used in high level plate modulated transmitters.
6. The power consumed by a screen modulated r-f amplifier is essentially constant regardless of the degree of modulation. Thus, problems of power line regulation and carrier shift during modulation are minimized. Without modulation, the efficiency of the screen grid modulated amplifier is somewhat less than that of a Class C plate modulated amplifier. However, as modulation is applied, the efficiency of the screen modulated amplifier improves until it becomes equal to that of the other system. If power consumption of large modulator tubes is given consideration, it may be found that the screen grid system offers better efficiency at high percentages of average modulation.

B. Modern Rectifier Circuits

Vacuum tubes have been eliminated in all high voltage, low voltage, and bias rectifier circuits of Continental Electronics transmitters in favor of semi-conductor units.

Mercury vapor tubes, ordinarily used for these services in the past, do not lend themselves as well to varying temperature conditions. They must be warmed prior to use and be kept warm to avoid "flash-back" during operation. They are bulky, somewhat less efficient than semi-conductor units, and contribute a considerable amount of heat that must be removed from the transmitter.

On the other hand, semi-conductor rectifier units do not require any warm up time; they may be operated efficiently at temperatures below zero; they contribute a minimum amount of heat

to be removed from the transmitter and provide a very compact physical package, with very long life characteristics.

If unattended or remote operation of the transmitter is contemplated, the semi-conductor characteristics become even more attractive.

Since semi-conductor rectifiers are used in the Continental Electronics broadcast transmitters, no damage will occur to the equipment if turned on from a cold start. This is true also for the vacuum tubes in the audio and radio frequency circuits.

The Continental Electronics AM broadcast transmitters are well suited to high ambient temperature operations and tropical climates. These transmitters have been environment tested under actual summertime ambient temperature conditions of well over 100° F.

C. Selenium Rectifier

Aside from instrument rectifiers, selenium units are the most widely used of all the semi-conductor types in the industry at the present time.

The special selenium rectifiers used in the Continental Electronics transmitters are rated by the Radio Receptor Company, Inc., their manufacturer, for continuous 100,000 hours estimated life at 35° C. ambient temperature. Their construction incorporates smaller size, lower voltage drop, less reverse leakage and higher current density than standard selenium units. An important processing technique has "pre-aged" the units during manufacture, thus eliminating output voltage fall-off throughout their life. Transformer "aging taps" are not required. This manufacturing innovation, called the "Petti-Sel" process, after the rectifier design developed in Western Germany by The Siemens Company, is now used exclusively in this country by Radio Receptor.

The operating life obtainable from a selenium rectifier unit is mainly a function of the temperature at which the rectifier operates. Moisture vapor is also a factor governing useful life. The rectifier construction and forced air cooling employed in the Continental Electronics transmitters take these factors into account, thus providing extremely reliable and long life operation in hot or cold climatic conditions.

1-3. Technical Summary

<u>Electrical</u>	<u>315B</u>	<u>316B</u>
Audio Input Impedance	150/600 ohms	150/600 ohms
Audio Input Level (100% Mod.)	± 10 ± 2 dbm	± 10 ± 2 dbm
Audio Frequency Response		
50-7500 cps	± 1 db	± 1 db
30-15,000 cps	± 1.5 db	± 1.5 db
Audio Distortion		
50-10,000 cps	2%	2%
Noise (Below 100% Mod.)	-60 db	-60 db
Carrier Shift (100% Mod.)	Less than 1%	Less than 1%
Type of Modulation	High-level Screen	High-level Screen
Frequency Range	535-1620 kc	535-1620 kc
Type of Emission	A3	A3
Frequency Stability	± 5 cps	± 5 cps
Type of Output	Unbalanced	Unbalanced
Output Impedance	50 ohms, or other specified	50 ohms, or other specified
Output Capability	5500 watts	10,600 watts
Max. Ambient Operating Temp.	$\pm 45^{\circ}$ C.	$\pm 45^{\circ}$ C.
Power Supply	208/230 V	208/230V
Line Frequency	60 cps (50 cps available)	60 cps (50 cps available)
Phase	3	3
Power Consumption	16 KW approx.	30 KW approx.
Power Factor	85%	90%
Permissible Combined Voltage Variation and Regulation	$\pm 5\%$	$\pm 5\%$
 <u>Mechanical</u>		
Transmitter Height	78"	78"
Transmitter Width	72"	72"
Transmitter Depth	41"	41"
Transmitter Floor Space	18 sq. ft.	18 sq. ft.
Transmitter Weight (unpacked)	2100 lbs.	2300 lbs.
Building Entrance Requirements	36" wide x 41" high	36" wide x 41" high

1-4. Tube Complement

<u>Function</u>	<u>315B</u>	<u>316B</u>
Two Oscillators	(2) 6AG7	(2) 6AG7
Two Oscillator Regulators	(2) 0B2	(2) 0B2
Buffer	(1) 807	(1) 807
R. F. Driver	(1) 4-65A	(1) 4-65A
Power Amplifier	(2) 4CX5000A	(3) 4CX5000A
1st Audio	(1) 807	(1) 807
2nd Audio	(1) 4-65A	(1) 4-65A
Modulator	(3) 4-65A	(3) 4-65A
Modulator Regulator	(1) 807	(1) 807
Regulator Reference	(1) 0B2	(1) 0B2
Feedback Rectifier	(1) 6X5	(1) 6X5
L. V. Rectifier	Selenium	Selenium
Bias Rectifier	Selenium	Selenium
H. V. Rectifier	Selenium	Selenium

1-5. R-F Amplifier and Modulator Circuits

As shown on Schematic Diagram No. 19002-E, the r-f tube lineup includes a crystal-controlled oscillator, untuned buffer, r-f driver stage and power amplifier.

The crystal oscillator stage is contained in a plug-in chassis designated as the Continental Electronics Type 30XT Oscillator. The plug-in feature facilitates easy removal for servicing. Two chassis sockets are included in the transmitter, and a selector switch is provided so that either of the oscillators may be chosen. The crystal used is the Type T-12A, which requires no temperature controlled oven. C201, on the front of each oscillator unit, is used for frequency adjustment. The oscillator tube is a Type 6AG7, with a Type 0B2 used as a screen voltage regulator. The cathode current of the oscillator tube is metered by TEST METER M203, in TEST METER Switch S201, position 1.

The buffer stage uses a Type 807 tube with untuned grid and plate circuits. Cathode bias resistor R209 is unbypassed and the cathode r-f voltage is coupled through coaxial cable to provide input voltage for the station frequency monitor. The cathode current of this stage is metered in position 2 of TEST METER Switch S201.

A Type 4-65A tetrode is used as the r-f driver. Its grid circuit is untuned, and its plate circuit is fixed-tuned and coupled to the power amplifier grid circuit through a low-pass network consisting of C214, L208, L221, and C216. A combination of fixed and grid leak bias is

used, the fixed bias being sufficient to protect the tube in the event of loss of excitation. Screen voltage is obtained through output control rheostat R224. This screen voltage adjustment varies the excitation to the power amplifier stage, and thereby controls the power output of the transmitter.

In the Type 315B, 5 KW Transmitter, two Type 4CX5000A tetrodes are used in the power amplifier stage, while the 10 KW Type 316B Transmitter uses three of these tubes. The 4CX5000A is a forced-air-cooled tetrode having a plate dissipation rating of 5000 watts. Cooling air is ducted from blower MB201 to the p-a tube shelf, which is a pressurized chamber. The air is forced through the anode cooling fins and thence through telescoping ducts above the tubes to the outside of the cubicle.

Amplitude modulation of the r-f carrier is accomplished by varying the screen voltage of the 4CX5000A tubes. Separate filament transformers are used for each 4CX5000A and primary taps are provided for adjustment of filament voltage. Individual cathode current metering is also provided for each p-a tube. The center tap of each filament transformer is connected, through the inter-cabinet connecting cable, to an overload relay in the rectifier unit to provide individual overload protection. The operation of the overload circuitry is described in Section 1-6.

A combination of fixed and grid leak bias is used in the p-a stage, the fixed bias being sufficient to protect the tubes in the event of loss of excitation. Grid current metering is provided at the test meter.

Screen voltage is fed to the stage from an electronically regulated source of d-c voltage which keeps screen voltage, and hence carrier output, constant regardless of screen current changes or line voltage fluctuations. The d-c amplifiers in the regulated screen supply serve also as modulator tubes. The description of this circuit is covered in following paragraphs.

Plate voltage for the p-a stage is obtained from the 7500-volt main rectifier. The output circuit, consisting of a "Pi" and a "Tee" network, is coupled to the plate circuit through blocking capacitor C229. This output circuit provides the necessary attenuation and, in addition, matches the antenna circuit resistance to the plate impedance of the p-a tubes. Sampling taps for the feedback rectifier are provided on static drain choke, L215. The station modulation monitor is driven from sampling coil L219. Another sampling coil, L222, provides an output sample which is rectified and presented at terminal TB202-7. This sample may be connected to the remote antenna current meter, M104, at TB102-12, as an indication of transmission line current. (Alternately, M104 is connected to a rectified sample of antenna current, as obtained from an external antenna base sampling unit.)

The power amplifier stage at 5 KW operates at a plate efficiency of from 35 to 40% with an unmodulated carrier. This figure increases to approximately 50 to 55% with 100% sine wave modulation. This is true since the power input to the tubes is constant, with or without modulation, although the total power output increases to 1.5 times the carrier power at 100% modulation. Since the efficiency of the stage is roughly proportional to the ratio of alternating plate voltage to d-c plate voltage, the efficiency will vary over the modulating cycle, reaching a maximum value at the positive peak of modulation. At 10 KW, the plate efficiency is kept above 41%, in order to limit plate dissipation to within the prescribed value.

The load impedance for the p-a tubes is such that the rated power output of the stage will be obtained when the alternating plate voltage is one-half its maximum value. Since the r-f plate voltage will double in magnitude at 100% sine wave modulation, large decreases in loading will cause positive peak flattening. By the same token, large increases in loading may over-dissipate the p-a tubes. For this reason, it is recommended that power output adjustments be made with the OUTPUT rheostat, rather than the LOADING control.

Proper loading of the stage can easily be ascertained by observing the p-a screen current, and by noting that the efficiency is within the limits stated previously. Tuning procedure is covered in Section 2.

The audio tube lineup consists of a pre-amplifier, a driver stage and a cathode-follower modulator stage. Also included are an overall feedback rectifier and a d-c amplifier regulator circuit.

The first audio stage uses a Type 807 tube in a tetrode, resistance coupled amplifier circuit. R299 is a balanced "H" pad which provides the necessary line loading and isolation. Input transformer T207 is a high-quality, wide-range unit which matches the grid circuit to the 600-ohm program line.

The modulator driver stage uses a Type 4-65A tetrode. Plate voltage for this stage is obtained from the bleeder resistor network connected across the 7500-volt power supply. Approximately 2500 volts d-c is supplied to plate load resistor R263. The high plate voltage on this stage is necessary in order that a large value of audio voltage can be obtained to drive the modulator with low distortion.

A filament hum-balancing potentiometer is included in this stage. Cathode current metering is provided in the test meter circuit.

The modulator tubes, connected in parallel, are operated as a conventional cathode follower and have a stage gain of about 0.75. The d-c voltage drop across cathode resistor R275 supplies screen voltage to the power amplifier. Since audio voltage also appears across R275, the screen voltage of the p-a stage is varied in accordance

with the audio input. Since it is the variations in p-a screen voltage that cause amplitude modulation of the r-f carrier, the average d-c value of screen voltage must remain constant over the modulating cycle if average carrier level is to be maintained. The screen current of the power amplifier stage will vary with modulation and, since this current flows through the modulator tubes, a corresponding variation in screen voltage could be expected if no correction were applied. In these transmitters, a regulator circuit provides a constant d-c voltage drop across the modulator tubes to stabilize the p-a screen voltage.

Figure 1-2 is a simplified representation of the modulator-regulator circuit. Tube V1 represents the modulator tubes. R_x is the varying load resistance presented by the screen circuit. Under conditions of no modulation, there is no screen current, and therefore the plate current of V1 is the current flowing through cathode resistor R1. The product of this cathode current and R1 is usually adjusted to be 430 volts d-c maximum. Tube V1 thus has a voltage drop equal to 1700-430, or 1270 volts. In order to hold the p-a screen voltage constant, the voltage drop across V1 must remain 1270 volts, regardless of plate current. Any increase in current must be accompanied by a decrease in resistance so that the product of resistance and current is always equal to 1270 volts. This is brought about by the action of tubes V2 and V3.

Caseous regulator tube V3 maintains ± 108 volts at the cathode of V2. Resistor R2 divides the ± 430 volts at the cathode of V1 down to approximately ± 93 volts at the grid of V2. Capacitor C1 removes the audio voltage. Resistor R3, which is the plate load for V2, drops the ± 1700 v dc to approximately ± 400 volts at the plate of V2. Since this is directly coupled to the grid of V1, through R4, V1 has a bias of 400-430, or -30 volts.

As modulation is applied, screen current is drawn by the p-a tubes, which flows through V1, causing an increased voltage drop. This means that the ± 430 volts must be decreasing. As the ± 430 volts decreases, the grid bias of V2 increases causing V2 to draw less current and hence decreases the drop across R3. Since the plate of V2 is going more positive, the bias of V1 is decreasing and therefore the resistance of V1 is decreasing. The voltage drop of V1 is in this way controllable by the action of V2 which is directed by the error voltage that appears at the cathode of V1.

The condenser C1 is used to prevent audio voltage changes from operating the regulator.

A sample of the output r-f envelope is taken from static drain choke L215 and applied to feedback rectifier tube V209. The modulation envelope is rectified, and the resulting audio voltage is fed back to the grid circuit of the first audio stage. Its magnitude is adjusted to cause 10 to 20 db of gain reduction.

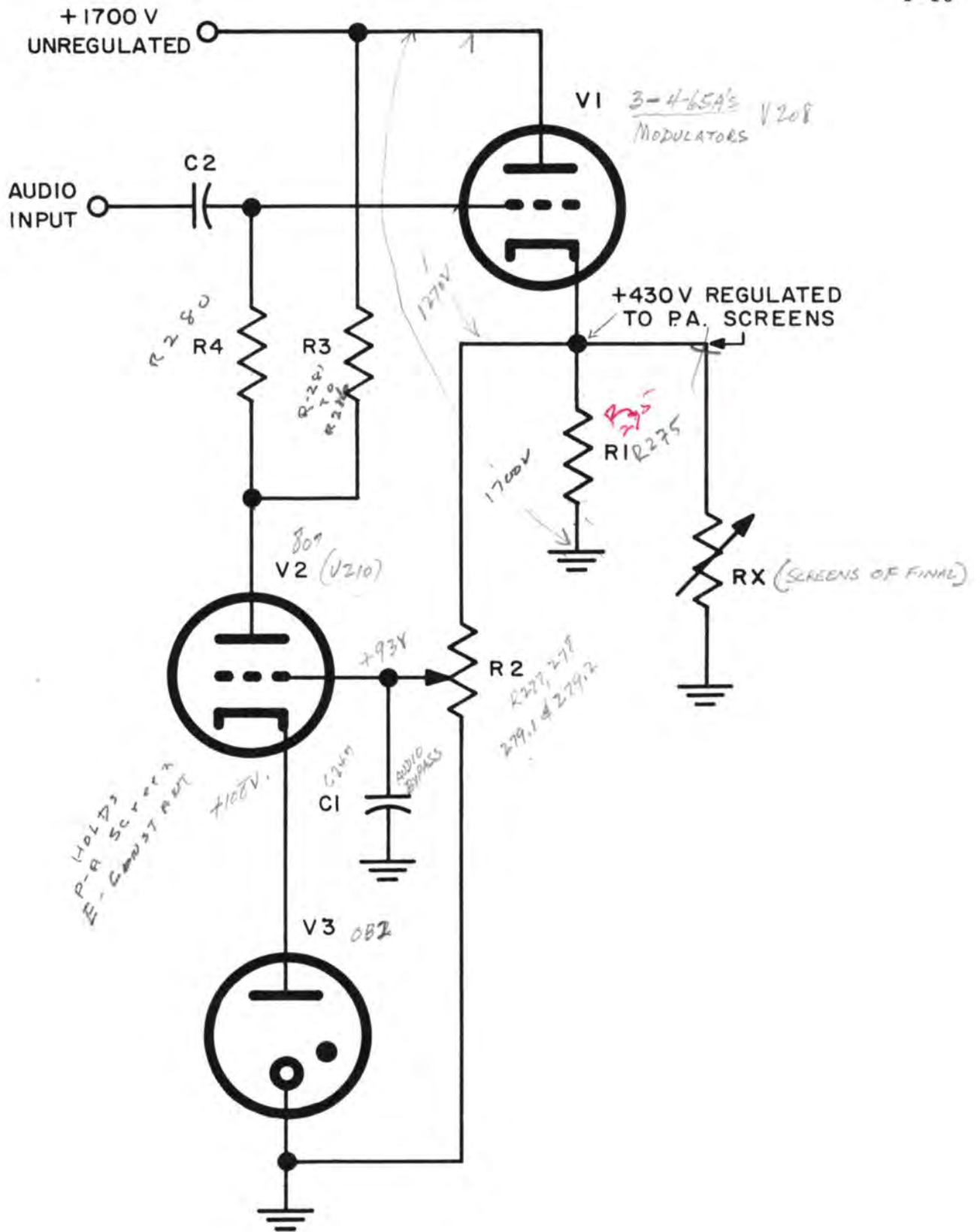

FIGURE 1-2
SCREEN MODULATOR-REGULATOR CIRCUIT, SIMPLIFIED SCHEMATIC

1-6. Protective Circuits

The protective circuits incorporated in these transmitters are of two basic types:

1. Fully magnetic circuit breakers that give a-c overload protection as well as d-c protection of the low voltage and bias supplies.
2. D-c overcurrent relays which protect the individual power amplifier tubes and the 2500-volt power supply.

The magnetic circuit breakers, when tripped by overload can be reset immediately by operating to the ON position. They require no time interval because they contain no thermal elements. Five of these breakers are used to protect the following:

CB101 - CONTROL - Protects the control circuit, relay coils, etc.

CB102 - BLOWER - Protects the two blower motors against overload.

CB103 - P.A. FILAMENTS - Protects the power amplifier filament transformers T201, T202, and T203.

CB104 - BIAS - Gives primary protection for the filament transformers T204, T205 and T206, and for bias transformers T101. It also gives d-c protection for the bias power supply.

CB105 - LOW VOLTAGE - Gives primary protection for plate transformer T102 and d-c protection for the low voltage power supply.

There are four d-c overcurrent relays: K108, K109 and K110 to protect the three power amplifier tubes, and K111 to protect the 7500 volt power supply. These relays function in an automatic reclosure circuit that operates in the following manner:

Relays K108, K109 and K110 are located in the cathode loads of the power amplifier tubes, and K111 is located in the negative return lead of the 7500 volt power supply. These are small, sensitive relays which have adjustable resistors in shunt with their operating solenoids. The normally closed contacts of the relays are wired in series with each other, and in series with the coil of plate contactor K102. The normally open contacts of these relays are wired in parallel and serve

to energize the stepping relay K107. If an overload should occur in any of the circuits associated with the four relays, the appropriate relay will operate and remove voltage from the plate contactor K102, thereby opening the 7500 volt power supply. At the same time, the normally open contacts of the relay will energize the step coil of K107. Simultaneous with removal of high voltage, the overload relay will return to its normal position and reclose the plate contactor. If the source of overload is no longer present, the plate voltage will stay on. If the overload persists, however, the relays will again function in the same manner. The stepping relay will count up to four of these reclosures and will then lock the circuit open. Depressing RESET switch S103 will return the stepping relay to its original position and at the same time will restore plate voltage.

One other form of protection is incorporated in the control circuit design. That is the protection to the power amplifier tubes afforded by vacuum switch K203. This switch, because of its spring loading and low mass, will pull up and drop out in a time interval of the order of 20 to 30 milliseconds. If a gas arc or any other overload should occur in the power amplifier circuit, the vacuum switch will quickly remove the 7500 volts from the tubes so that the stored energy in the filter capacitors will not discharge into the arc. The switch will interrupt large values of current quickly and safely, and can withstand extremely high voltages. Because of the transient nature of the interrupting wave, very high voltages can arise on the switch assembly. It is important, therefore, to observe the maintenance schedule in cleaning the glass bulb of this switch, to prevent breakdowns across the outside of the envelope.

For personnel safety, shorting switches, operated by the front doors, are incorporated in the transmitter. The switch in the rectifier-control unit short-circuits the /850, /1700, and /7500 volt wires. The switch in the amplifier short-circuits the /850 and /1700, and the /7500 volt circuits, the latter on the filter capacitor side and on the tube side of the vacuum switch, thereby discharging the plate blocking capacitor C229, and bypass capacitor C230.

NOTE: The -120 v dc bias is not removed when the doors are opened, and is therefore not shorted by the door grounding switches.

1-7. Power Supplies

Three d-c power supplies are used in the transmitter. The bias power supply provides grid bias for the r-f driver stage and the power amplifier stage. The low voltage rectifier supplies plate and screen voltage for all tubes except the plates of the audio driver and power amplifier. The 7500 volt rectifier supplies plate voltage for the p-a tubes and for the audio driver.

A. Bias Power Supply

The bias power supply provides -120 v dc at 150 ma, and uses four selenium rectifiers in a full-wave center-tapped configuration. The bias voltage is used to operate the low voltage contactor K106, as well as to provide grid bias in the r-f stages.

B. Low Voltage Power Supply

The low voltage rectifier is arranged in a bridge circuit and provides \pm 850 v dc at 150 ma, and \pm 1700 v dc at 200 ma. Eight selenium rectifiers are used. Four Type SE11S34H700 are used in the 850-volt load circuit, and four Type SE11U46H688 are used in the 1700-volt load circuit. These rectifiers are operated at roughly one-half their rating with respect to forward current and peak inverse voltage and, with the cooling provided by blower MB101, should give many years of trouble-free service. The low voltage supply is protected from a-c and d-c overloads by circuit breaker CB105.

C. 7500 Volt Power Supply

The high-voltage rectifier supplies 7500 v dc for the power amplifier tubes. In the Type 315B 5 KW transmitter, the supply is rated 7500 volts at 2 amperes; in the Type 316B 10 KW transmitter, the larger rectifier used is rated at 7500 v dc, 4 amperes. The rectifier arrangement is a conventional three-phase full-wave circuit using 60 selenium rectifiers. Ten units are connected in series in each leg of the rectifier. Forced-air cooling is provided by blower MB101 and this, along with conservative use, should result in years of rectifier service.

In the Type 315B transmitter, two plate transformers are open delta connected in the 7500-volt primary supply, and filter reactor L105 has its two separate windings connected in series. In the Type 316B 10 KW transmitter, a third transformer is added and the windings of filter reactor L105 are connected in parallel.

1-8. Test Metering, Scale Interpretation

The following table will be of benefit in interpreting the 315B/316B test meter readings, which are presented in "percent of normal." It should be noted that the indications are approximate only, and are intended as average readings in a normal situation. A chart of specific meter readings is recorded for each transmitter and is included in the instruction book furnished with that transmitter.

<u>Position</u>	<u>100% Reading</u>	<u>Normal Reading 5 KW</u>	<u>Normal Reading 10 KW</u>
Osc.-K	150 ma	10%	10%
Buff.-K	110 ma	25-35%	25-35%
Dvr. -G	20 ma	15-30%	15-30%
Dvr. -K	110 ma	45-65%	45-65%
PA-G	300 ma	35-60%	35-60%
PA1-K	2.9 a	30-35%	30-45%
PA2-K	2.9 a	30-35%	30-45%
PA3-K	2.9 a		30-45%
1st Audio-K	20 ma	35-45%	35-45%
2nd Audio-K	110 ma	25-30%	25-30%

1-9. Power Cutback (Optional)

Certain Type 316B transmitters are optionally equipped for instantaneous power switching from 10 KW to 5 KW, or vice-versa. Similarly, Type 315B units may be cut back from 5 KW to 1 KW. Power switching is accomplished by operating pushbutton switches marked "High" and "Low" on the right hand rectifier control panel. The following description illustrates cutback from 10 KW to 5 KW.

A. 5 KW to 10 KW Power Change

If the transmitter is operating on low power (5 KW) and the "High" pushbutton, S104.1, is pushed, the plate contactor, K102, opens, the latching relay, K103, locks in and the high voltage contactor, K115, is energized. K115, when energized, switches the necessary taps of the secondary of the plate transformers. When S104.1 is released, the plate contactor, K102, again closes and the power amplifier tubes then receive plate power at approximately 7500 volts, which is the power needed for 10 KW operation. Auxiliary contacts on plate contactor K102 prevent operation of the switching relays until plate voltage is removed.

With K103 in the locked-in (10 KW) position, the following relays are energized:

K115 - High voltage contactor closes, connecting the plate transformer secondaries for 7500 volts dc to the plates of power amplifier tubes.

K204 - Screen relay contact closes, increasing the power amplifier screen voltage.

K209 - R-f drive relay contact opens, increasing the r-f drive to the power amplifier grids.

K210 - Audio relay closes and attenuator R297 is removed from the audio feed line, increasing the audio signal to the modulator system.

B. 10 KW to 5 KW Power Change

If the transmitter is operating on high power (10 KW) and the "Low" pushbutton, S104.2, is pushed, the plate contactor, K102, opens, the latching relay, K103, is released, and the high voltage contactor, K115, is de-energized. K115, when

de-energized, switches the high voltage rectifiers to the necessary taps of the secondary of the plate transformers. When S104.2 is released, the plate contactor, K102, again closes, and the power amplifier tubes then receive plate power at approximately 6000 volts, which is the voltage needed for 5 KW operation.

With K103 in the released position, the following relays are de-energized:

K115 - High voltage contactor opens, connecting the plate transformer secondaries for 6000 volts dc to the plates of the power amplifier tubes.

K204 - Screen relay opens, reducing the power amplifier screen voltage.

K209 - R-f drive relay opens, reducing r-f drive to the power amplifier grids.

K210 - Audio relay opens and attenuator R297 is inserted in the audio feed line, decreasing the audio signal to the modulator system.

Drawing No. 19345-B shows the additional components and wiring required for 10KW/5KW cutback operation. Note that the standard Type 315B/316B transmitter, when provided for straight one-power operation, and unequipped for cutback, will contain all standard components except those shown as "Added" on Drawing No. 19345-B. That is, K103, K204, and the "High" and "Low" power pushbutton arrangement is a standard part of the transmitter. On non-cutback units, the power reduction feature may be used to reduce power somewhat for testing purposes.

The Type 315B 5 KW transmitter, when provided with power cutback from 5 KW to 1 KW, will operate essentially the same as described above, except that the operating voltages will be those required for 5 KW and 1 KW operation. Refer to drawing No. 19360-B for the proper connections for this mode of operation.

1-10. Conelrad Frequency Changing

The Type 315B/316B transmitter, when supplied with CONELRAD switching, is modified by the addition of the following parts:

Crystal oscillator selector switch S202 is removed and is replaced by two DPDT relays, K205.1 and K205.2.

The plate circuit of r-f driver tube 7104 is tuned by the addition of relay K206, which selects a fixed tap on driver plate coil L221.

The plate circuit of the final amplifier tubes is tuned and loaded by the addition of relay K207, which selects the proper tap on plate coil L216 and adjusts loading condenser C232.

Appropriate wiring changes are made, which include interlocking of plate voltage relay K102 through contacts on K207 so that plate voltage will be removed while the relays are operating. In most cases, the Type 315B 5 KW transmitter operates at its full output on the Conelrad frequency, and the Type 316B 10 KW transmitter is operated at either its full output, or is reduced in power to 5 KW, for Conelrad operation. For these reasons, the existing LOW-HIGH POWER pushbutton controls may be utilized for Conelrad/Regular frequency changing, and for simultaneous reduction of power, if required. Control circuit diagram No. 19947-B illustrates the manner in which this is accomplished.

The Conelrad switching relay, K207, in the output circuit of the transmitter is supplied with four auxiliary switches. Two of these are used to interrupt the coil operating voltage of this relay after it has closed, and two are used to cut off plate voltage while switching by opening the interlock circuit at TB108-1 and -2. These switches are adjusted so that K102 is dropped out before K207 opens and so that K102 is not restored until K207 is closed. This is done to prevent arcing at the r-f contacts of K207.

The Type 30XT oscillator containing the Conelrad crystal is inserted in J201.2, and the Regular oscillator in J201.1. The oscillator switching relays, K205.1 and K205.2 are de-energized in Regular operation, corresponding to the HIGH POWER position of the control circuit. These two relays switch the DC plate voltage, and the metering and RF output connections between the two oscillators.

The 807 buffer stage is untuned, therefore no switching is required at that point. Since the output of each oscillator is the same, the output of the buffer stage is constant at both frequencies.

The 4-65A RF driver tube is retuned by K206, which is de-energized in Regular operation. When energized to the Conelrad position, it changes the inductance of L221. This relay is located in the PA plenum. The output of the driver stage is relatively the same at both frequencies, so that readjustment of OUTPUT control R224 is not generally required.

The output network of the Type 315B/316B transmitter consists of a "Pi" followed by a "Tee". Since the Tee network is not retuned for Conelrad operation, its input impedance will change from the normal midpoint impedance to a value of R/jX , and the Pi network will be required to transform this impedance to the correct value on the Conelrad frequency. This is accomplished by relay K207, which selects the proper tap on L216 and the proper value of capacity on the output of the Pi network.

Conelrad carrier squelching may be accomplished by operating excitation release relay K201 by external means. A switch may be inserted in the coil voltage feed to excitation release relay K201, by removing the strap between TB201-21 and -23, and installing a normally closed switch across these terminals. For remote control operation, this switching is normally performed by the "EXTRA" relay function.

1-11. 50 Cycle Operation

When supplied for 50 cycle operation, the following changes are made in the Type 315B/316B components supplied:

1. Contactor K102 is supplied with a 50 cycle coil.
2. Motor blower MB101 is supplied as a Peerless utility standard blower, Model 1-3/4, with 3/4 HP motor, 950 RPM at 50 cycles, 208-220/440 volt, 50 cycle, 3 phase, Motor frame 803.
3. Motor blower MB201 is supplied as a Peerless utility blower, high speed, with 1 HP motor, 1450 RPM at 50 cycles, 208-220/440 volt, 50 cycle, 3 phase.

Additionally, it should be noted that the plate hours meter, M103, indication must be multiplied by 5/3, or 1.2, to obtain the correct reading at 50 cycles.

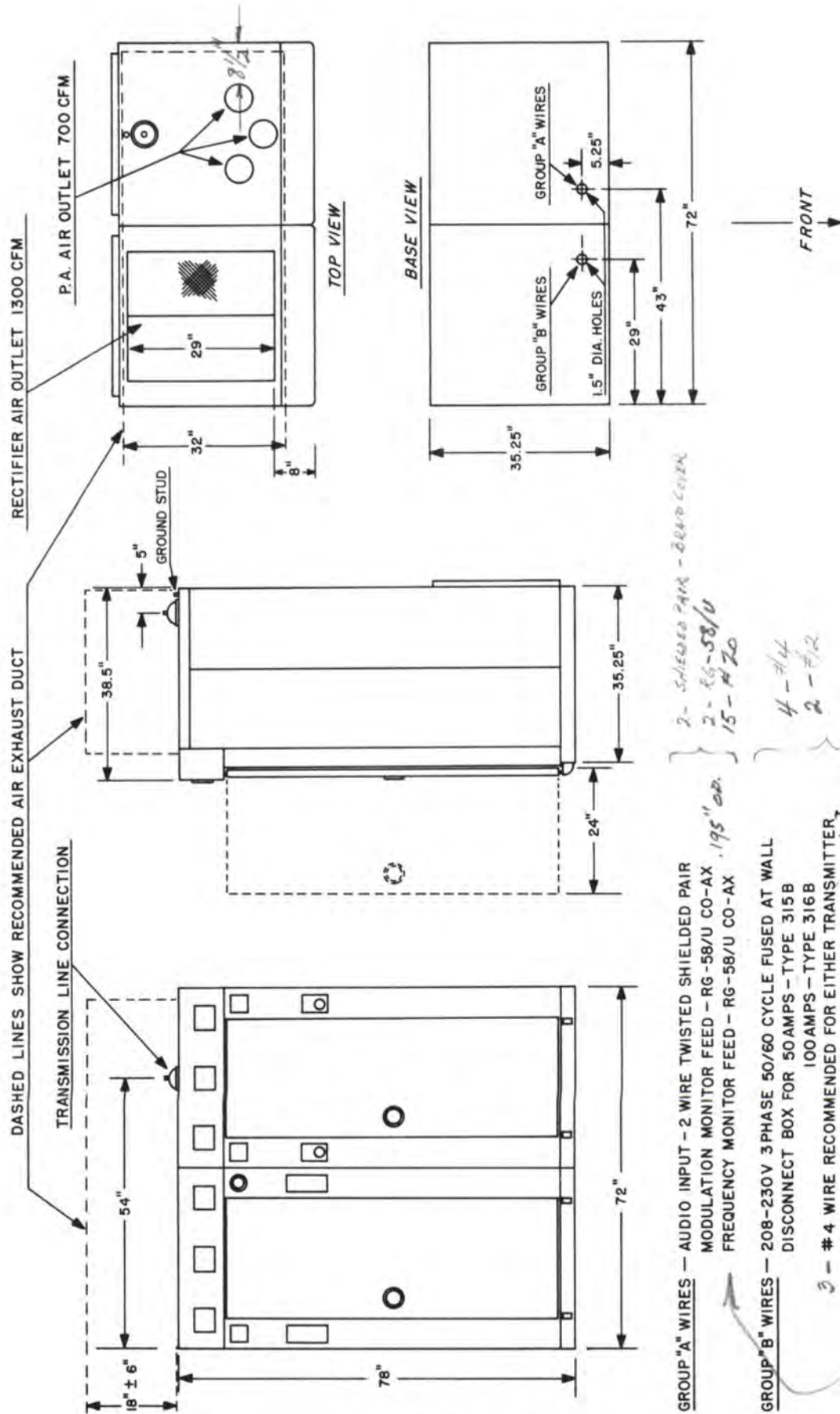

FIGURE 2-1
 INSTALLATION DIAGRAM TYPE 315B/316B TRANSMITTER

SECTION 2. INSTALLATION AND OPERATION

2-1. Unpacking and Assembly

All components which are fragile or might suffer damage in domestic shipment are removed from the cabinets at the factory and packed in separate boxes. Inspect all the crates and boxes included in the shipment. If there is evidence of damage to any part of the shipment, save the packing material and make a claim to the transportation company.

The following procedure may be used to assemble the transmitter and ready it for operation:

1. Set the two cabinets in position in the operating room. The rectifier and control cabinet is placed to the left of the amplifier cabinet, as viewed facing the front of the equipment. If the floor is not level, place shims under the corners of the cabinets as necessary. Check the operation of the front doors. If they do not close and latch properly, adjust the shims accordingly. Each door is fitted with hinge pins, the top socket for which may be adjusted to obtain proper closure and fitting of the door seal. Likewise, an adjustable socket is provided for the top latching rod.
2. Remove all shipping tape and packing material from the wiring and components inside the cabinet.
3. Install the h-v plate transformers, T103.2 and T103.3 (and T103.1 in the Type 316B). Place them on the racks provided for them with the terminals facing the center of the rectifier cabinet. In the 315B transmitter, install the two transformers on the right-hand rack. In the 316B transmitter, install the third transformer in the rear of the left-hand rack. Connect the wiring according to schematic diagram Drawing No. 19001-E.
4. Install filter reactor L105. This is placed in the front of the left-hand rack with terminals facing the center of the cabinet. Connect the wiring per Drawing No. 19001-E.
5. Install the two sections of high-voltage selenium rectifier assembly. Note that the two are not identical, but are mirror images of each other. The three high voltage ac connections are made at the front by means of the three 6-32 screws provided. Install the two rectifier assemblies through the hole in the top of the rectifier cabinet so that these connecting studs are at the front center of the cabinet.

CAUTION

Handle the rectifier assemblies by the metal channels. Never attempt to use the rectifier units or bakelite supports for handles.

Connect the three ac wires to the studs provided and at the same time connect the two assemblies together at these three places with the bus wire provided. The two dc wires are connected to the bottom rear of the assembly with the negative lead to the left and the positive high voltage wire to the right.

6. Install the larger of the two blower motors in the rectifier unit as shown in Figure 5-11. Connect the three wires to the terminal strip on the blower frame. The three wires can be connected in any order, and will need changing only if the motor rotation is backward. (See Section 2-2)
7. Install the cabinet inter-connecting cable. One end of the cable is already connected and packed in the rectifier unit. Feed the other end of the cable through the hole in the bottom right side of the rectifier and connect to TB201, S205, and ground block E201 in the amplifier unit.
8. Install the 1600 ohm globar resistor, R295, and the two 5 megohm resistors, R296 and R298, in the amplifier unit. (See Figure 5-3.)
9. Install the vacuum padding capacitors in the clips provided. (See Figure 5-4.) Consult the table of coil and capacitor settings for values used in various locations. To install C233, remove the cover from the "Tee" network compartment in the center rear portion of the cabinet.
10. Install the blower, MB201, in the amplifier unit. The canvas air duct is fastened into the p-a tube shelf. Fasten the other end onto the blower outlet with the clamp which is secured to the blower. Make sure that there are no twists or kinks in the canvas and tighten the clamp securely.
11. Install the vacuum tubes, crystals and crystal shield cans. Before installing the 4CX5000A tubes, loosen the anode connector straps so that the tube will drop through them. When installing the 4CX5000A's, use a straight up or down and twisting motion. Never use a rocking motion!

12. Connect the three-phase power line at TB105 in the rectifier cabinet. Connect the 115 V 60 cycle control voltage to terminals 23 and 24 on TB101, observing the proper ground polarity. Connect the earth ground lead to E101. Connect the program line, modulation monitor and frequency monitor wires to TB202. Connect the transmission line to E206 on top of the amplifier cabinet.
13. Install the air filters in the rear of each cabinet, making certain that the arrows on the sides of the filters point toward the inside of the cabinets.

2-2. External Air Supply

In order to prevent re-circulation of transmitter exhaust air into the air inlet passages, some means for separating inlet and outlet air flow should be provided.

It is suggested that the inlet air be ducted into the rear of the transmitter cubicles through a direct duct to the outside of the transmitter building. The exhaust air may then empty directly into the room. Alternately, an exhaust duct may be installed from atop the transmitter to the outside of the building. In the latter case, the duct should be of sufficient size to prevent back pressure and consequent re-circulation between the exhaust ports of the transmitter cubicles. (See Installation Diagram, Figure 2-1.)

It is desirable, particularly if the transmitter room is small, to install an external exhaust fan in the building outside wall, to help in removal of the heated transmitter air. If the transmitter is located behind a partition wall, the exhaust fan may be thermostatically controlled, and if desired, special ducting and damper arrangements may be used to utilize the transmitter air temperature rise for winter-time building heating.

2-3. Operational Check

With 208 or 230 volt, 3 phase, 60 cycle power connected to TB105, and with 115 volt, 60 cycle power connected to terminals 23 and 24 of TB101, the transmitter is ready to start in the following sequence. First, make sure all control switches and breakers are "off".

1. Operate circuit breakers CB101, CB102, CB103, CB104 and CB105 to the ON position. Close both cabinet doors.
2. Operate MASTER switch S101 to the ON position. This will energize contactor K101 which will in turn energize the blower contactor, K104. Both blowers should start.

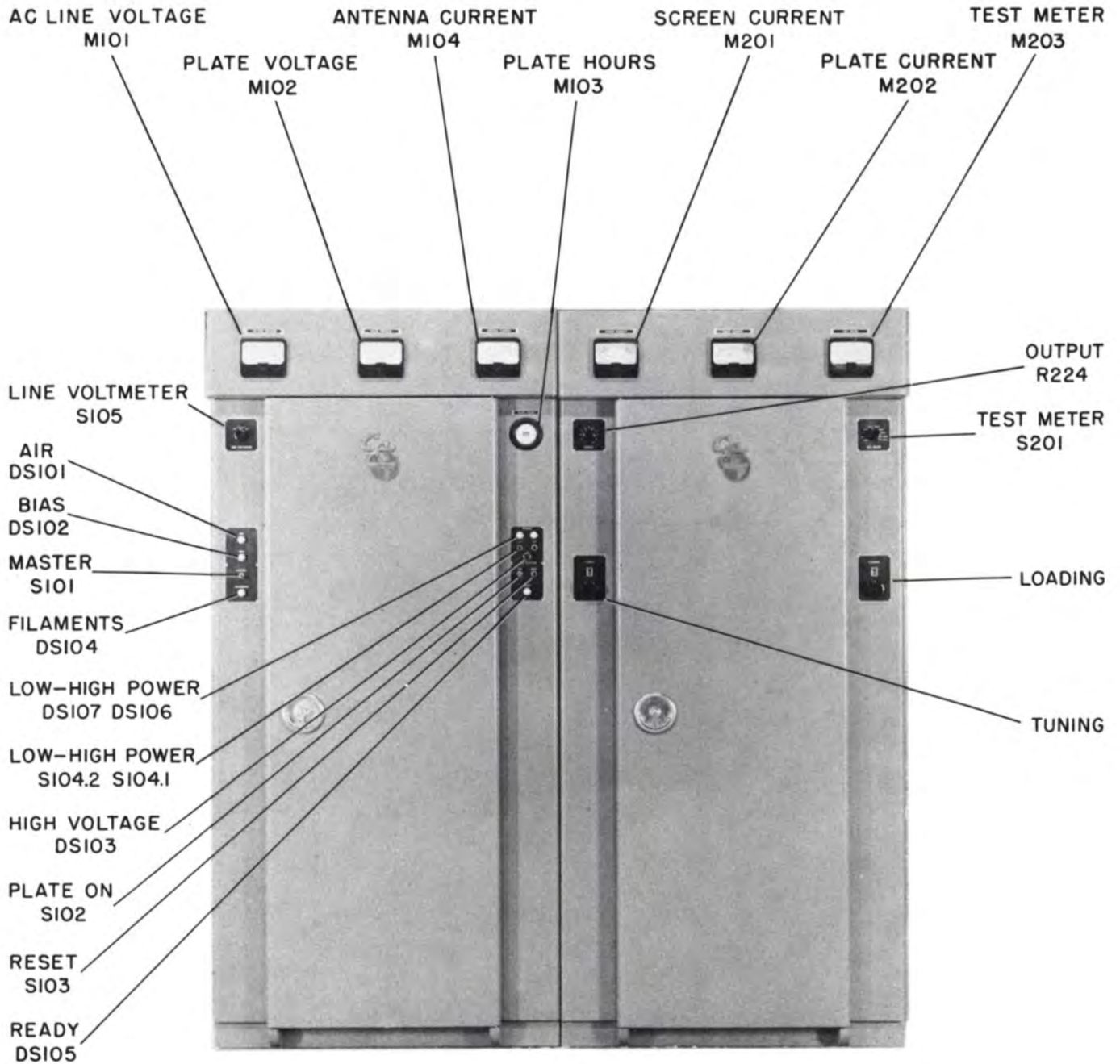

FIGURE 2-2
LOCATION OF CONTROLS

Turn off MASTER switch S101. Open the front door of the rectifier-control unit and note that the BLOWER HOLDOVER relay, K112, is running toward zero. The holdover time should be adjusted to at least 60 seconds. When the hand reaches zero, blower contactor K104 will drop out. As the blowers coast to a stop, note the direction of rotation of each. Looking from the motor end, the blower must rotate in a clockwise direction. If it is rotating counter-clockwise, interchange any two of the motor wires.

Important! If at any time the blowers are removed, check the rotation when replacing. Counter-clockwise rotation may operate the air switches but damage to components may result from decreased air flow. If ever the phase rotation of the power line is changed, a corresponding change must be made in the blower power feed.

3. Close both cabinet doors. Operate MASTER switch S101 to the ON position. The blowers will reach operating speed very quickly. Note that as the air flow switches close, AIR indicator lamp DS101 will light. Failure of this lamp to light means either that the lamp is defective or that there is insufficient air flow to operate the air switches. S107, located in the rectifier-control unit, operates in a large volume of air. S204, located in the amplifier unit, is more sensitive and will not operate if air flow is decreased by clogged air filters, clogged cooling fins on power amplifier tubes or stopped up air outlet. Observe the maintenance schedule on the air filters and clean according to instructions. Periodic inspection of the air system for leaks, clogged tube fins and large accumulations of dust will insure cool operation and increased tube life.

As AIR indicator lamp DS101 lights, filament contactor K105 will be energized, and FILAMENTS lamp DS104 will light. This will apply filament voltage to all of the vacuum tubes and at the same time will energize the bias power supply. A short time delay is provided by thermal relay K113, to allow for tube filament warm-up. Upon operation, K113 contacts connect the bias supply output to the door interlock circuit, and thence to the dc coil of the low voltage contactor.

If the door interlock switches, S108 and S203, are functioning properly, the BIAS indicator lamp, DS102, will light, and at the same time, the low voltage contactor, K106, will pull up, which will light the READY lamp, DS105, and apply 4850 volts dc and 41700 volts dc to the various circuits in the amplifier unit.

Check the operation of the door interlock switches by opening and closing each door separately, and noting that the READY lamp, DS105, and the BIAS lamp, DS102, are extinguished as the doors are opened.

4. The transmitter is now ready for the application of plate voltage to the power amplifier tubes. No modulation should be applied at this time.

Operate the HIGH VOLTAGE switch, S102, to the ON position. This will energize the plate contactor, K102, and apply power to the plate transformers, T103.1, T103.2 and T103.3. Observe PLATE VOLTAGE meter M102.

NOTE - If the "Power High-Low" circuit is in the LOW position, the P.A. screen voltage will be reduced. For full power output, always operate HIGH POWER pushbutton.

As the HIGH VOLTAGE switch, S102, is closed, two other functions are performed in addition to the closing of plate contactor K102. Vacuum switch K203 has its actuating solenoid wired in parallel with K102, and because of its higher speed, will be heard to close slightly before K102. Surge contactor K202 also has its actuating solenoid wired in parallel with K102. However, K202 is slightly delayed in closing. This is due to the action of thermistors RT201 and RT202, which are wired in series with the coil of K202. These thermistors have a high cold resistance. As voltage is applied to the circuit, the resulting current warms the thermistors and in so doing, decreases their resistance until their voltage drop is low enough to energize K202. The thermistors are then shorted out by contacts on K202 so that they will cool and be ready for subsequent reclosures. The other contacts on K202 short out resistor R295 which is in series with the filter condensers, C250.1, C250.2, and C250.3.

The presence of R295 in series with these condensers limits the inrush current in the main plate transformers which would otherwise be quite high, because of the charging current in the "resistanceless" condensers.

5. Check the readings of the meters, including all of the "Test Meter" positions against the typical readings given in the meter chart.

2-4. Operation

All functions of normal operation are performed using the controls and instruments on the transmitter front panels. Figure 2-2 illustrates the location of these controls.

To start the transmitter, place the MASTER switch in the ON position. It is customary to wait fifteen to thirty seconds for the tube cathodes to heat before turning HIGH VOLTAGE switch S102 on. However, if it is desired to get on the air as rapidly as possible, S102 may be operated at once and high voltage will be applied automatically upon operation of time delay relay K113.

To shut the transmitter down, turn the HIGH VOLTAGE and MASTER switches off.

2-5. Tuning

The elements comprising the output network of the transmitter are adjusted at the factory during testing so that very little, if any, tuning will be necessary after the transmitter is installed.

Two tuning controls are presented on the front panel for external adjustment. The TUNING control operates C231.1 for tuning the p-a plate circuit. The LOADING control operates C232.1 for loading adjustments in the p-a plate circuit. As stated previously, the loading control should not be used to adjust power output.

The p-a stage may be determined to be properly loaded by observing that the plate circuit efficiency is approximately 35-40% (5 KW; above 41% at 10 KW.) Excessive loading of the stage can be determined by poor efficiency. If this is evident, rotate the LOADING adjustment counter-clockwise, at the same time re-adjusting the TUNING and OUTPUT controls, until the proper efficiency is obtained.

One other means of checking for proper loading is to observe the carrier level meter on the station modulation monitor. If, when the transmitter is modulated 100%, the carrier level meter reading decreases by more than 2 or 3%, the loading is insufficient. In this case, rotate the LOADING control clockwise, at the same time re-adjusting the TUNING and OUTPUT controls until the carrier shift is 1% or less.

Screen current potentiometer R278 and P. A. bias adjust resistor R227 have been adjusted at the factory for minimum P. A. screen current consistent with proper operating efficiency. Should re-adjustment be necessary, a slight change in R278 should be all that is required. The screen current should not be increased more than 10 to 15 percent of its original zero modulation test value by this adjustment.

(46%)

2-6. Adjustment of Hum Balance Control

When the modulator driver tube, V207, is replaced, the residual noise level of the transmitter should be checked. If the noise level is less than 55 db below 95% modulation, hum balance potentiometer R258 should be readjusted. This is done in the following manner:

1. Calibrate the distortion and noise meter in the prescribed manner with the transmitter modulated 95% with a steady tone of 1000 cps.
2. Remove the tone and measure the noise level of the transmitter.
3. Make note of the noise level and adjust R258 to obtain a minimum reading on the noise meter.

2-7. Use of Overall Feedback

As explained previously, the use of overall feedback will improve the performance of the transmitter considerably. The feedback circuit is adjusted at the factory for optimum results. Feedback in excess of the optimum value may result in oscillation of the audio amplifier. Less than optimum value will, of course, fail to utilize the desirable features of the circuit.

It has been found that 10 to 20 db of overall feedback will give excellent results with good circuit stability. The amount of feedback in use can easily be determined by measuring the audio amplifier gain reduction caused by the feedback. This is done in the following manner:

1. Remove the overall feedback by adjusting control R245 to minimum setting, or by short-circuiting resistor R248 to ground.
2. Modulate the transmitter 100% with a 1000 cps tone. Note the audio level of the tone.
3. Remove the short from R248, or readjust R245 to its original position.
4. Feed the same audio level of 1000 cps tone into the transmitter and note the percentage modulation.

5. The reduction of percent modulation in db, noted in step 4, will be equal to the amount of feedback used, also in db. If the meter has no db scale, this can easily be computed, for example:

Suppose that feedback reduced the percent modulation to 50%, then the voltage ratio is 100:50, or 2:1. This is equal to 6 db.

Since feedback reduces the overall gain of the system, then operation without feedback will require a program input level less than that required with feedback by the amount of feedback used. For instance, the normal program level required for 100% modulation is $+10$ dbm $+2$ db. If 10 db of feedback is removed, then the program level will require reduction to 0 dbm $+2$ db.

2-8. Tuning Charts

The charts shown on the following pages are included as an approximate indication of the correct value for the components indicated. The charts are included for informational purposes only, since all components to which they refer have been correctly chosen and adjusted at the factory for the specific operating frequency.

Should a change in operating frequency be required, this information will aid in establishing new operating parameters. Except for these indicated changes, and, of course, the provision of new crystals, only the RF driver plate tuning circuit need be retuned.

TYPE 315B/316B TRANS.

REQUIRED CAPACITANCE

CP31

$$X_C = \frac{R_L}{Q} = \frac{1000}{6} = 168\Omega \text{ (5Kw)}$$

$$= \frac{500}{6} = 84\Omega \text{ (10Kw)}$$

$$R_L = \frac{(E_p \times 8 \times 707)^2}{20,000} \approx 1000\Omega \text{ (5Kw)}$$

$$= \frac{(E_p \times 8 \times 707)^2}{40,000} \approx 500\Omega \text{ (10Kw)}$$

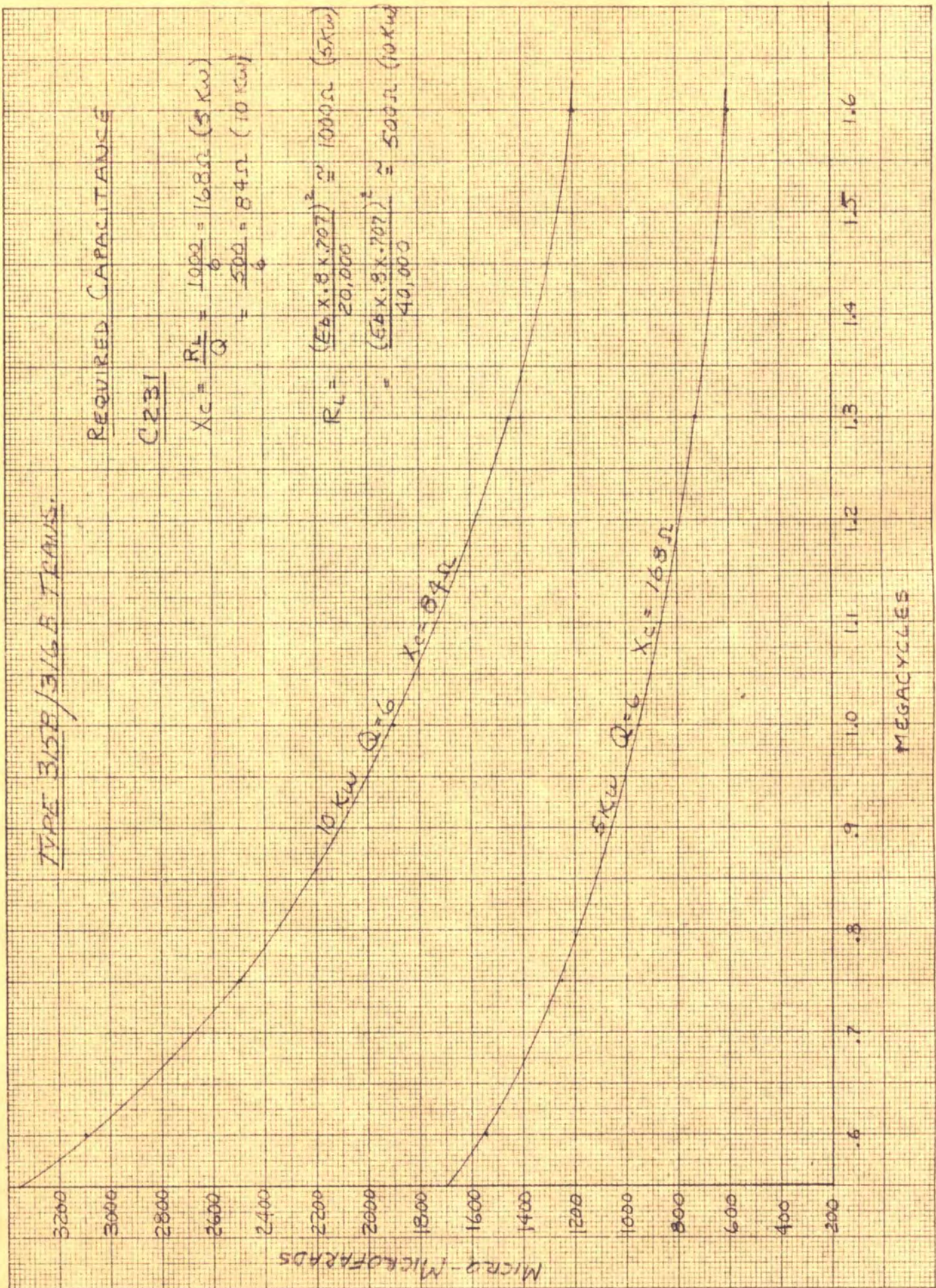

TYPE 315B/316A TRANS.

REQUIRED CAPACITANCE

C232

$$X_C = -R_L \sqrt{\frac{R_A}{R_L - R_A}} \quad R_A = \frac{X_{C231}}{Q}$$

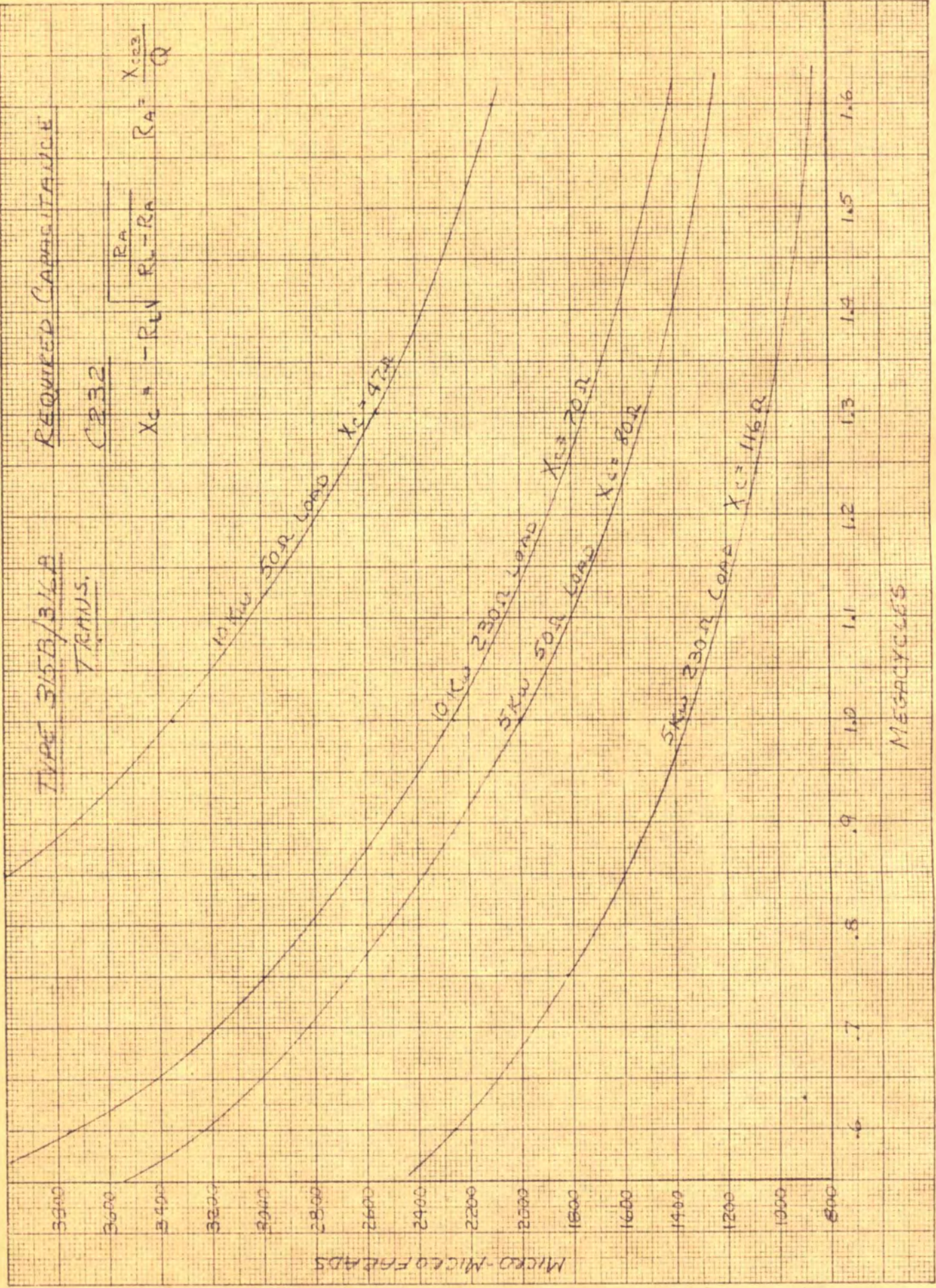

MEGACYCLES

TYPE 315B/316B TUBES. REQUIRED INDUCTANCE

L 216

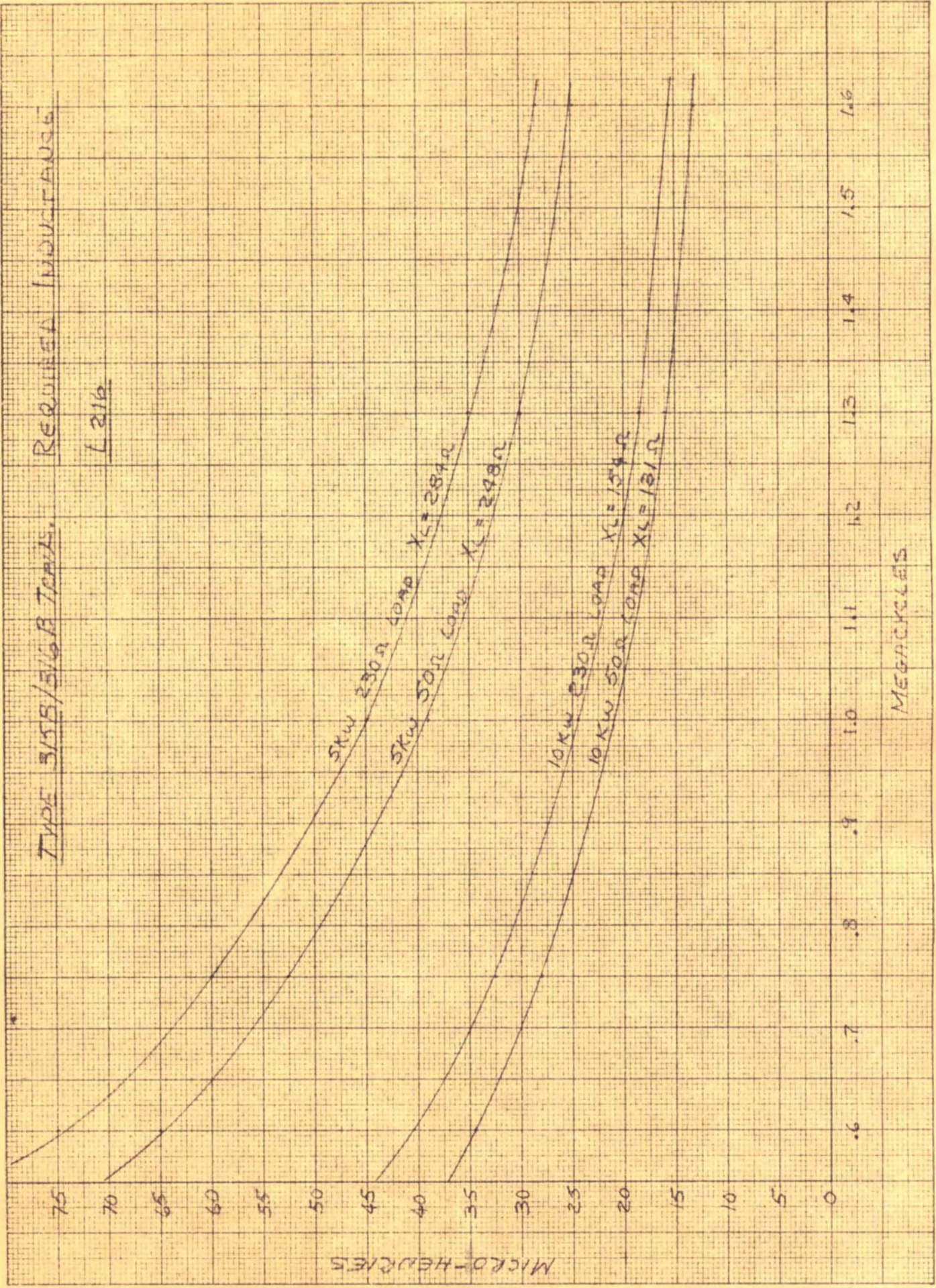

MEGACYCLES

MICRO-HENRIES

TYPE 315A/316B TRANS

REQUIRED CAPACITANCE
CZB3

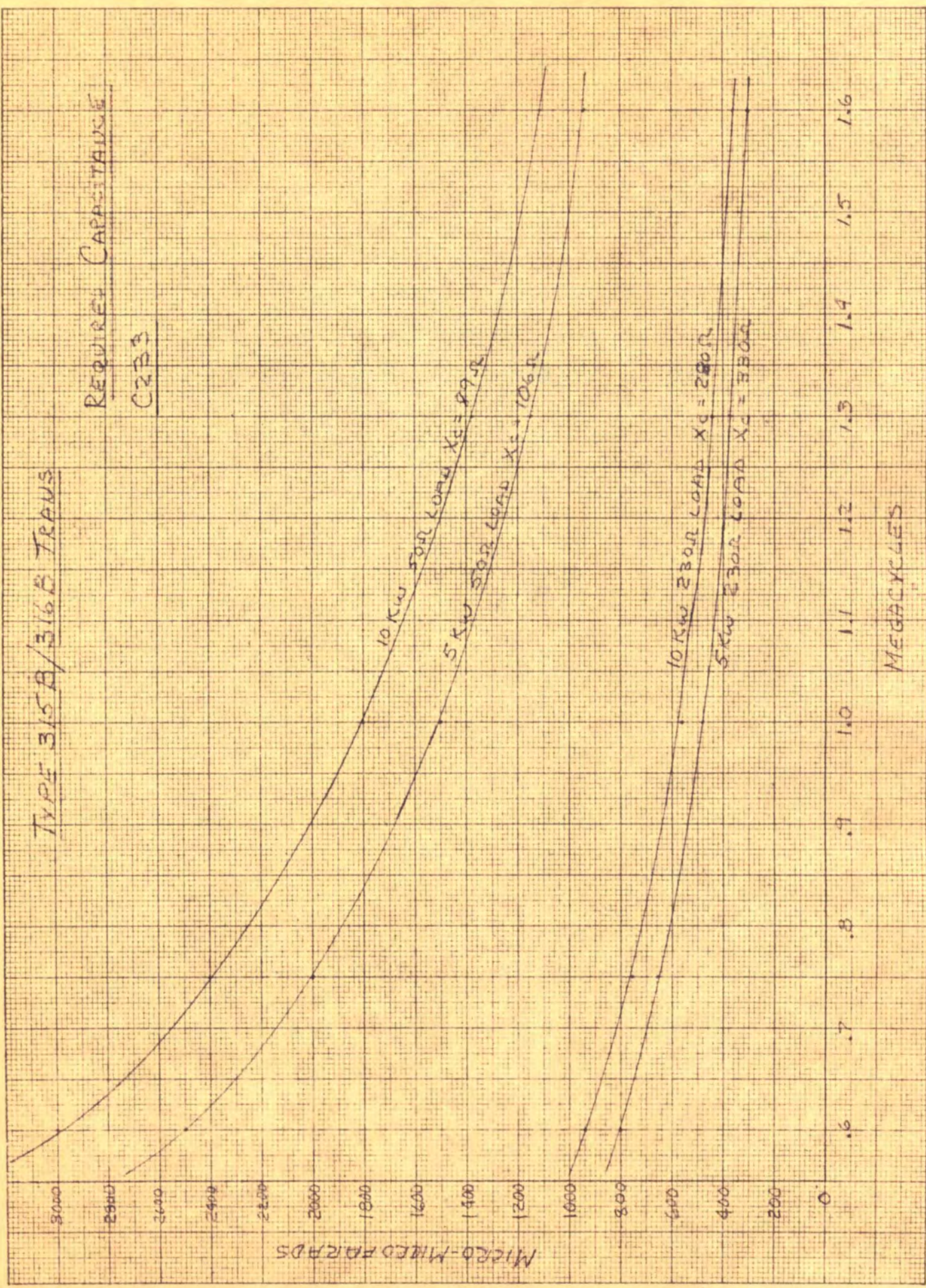

TYPE 315B/316B TRANS.

REQUIRED INDUCTANCES

L217 & L218

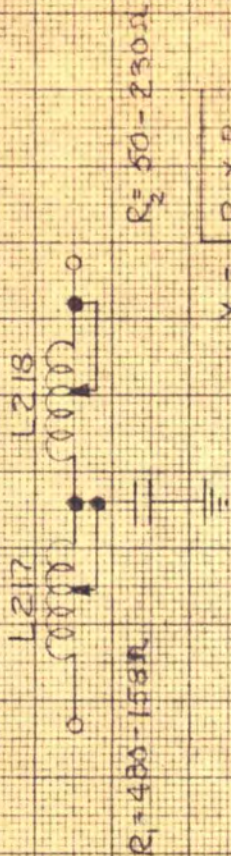

$$X_L = \sqrt{R_1 \times R_2}$$

$$X_{L217} = X_{L218}$$

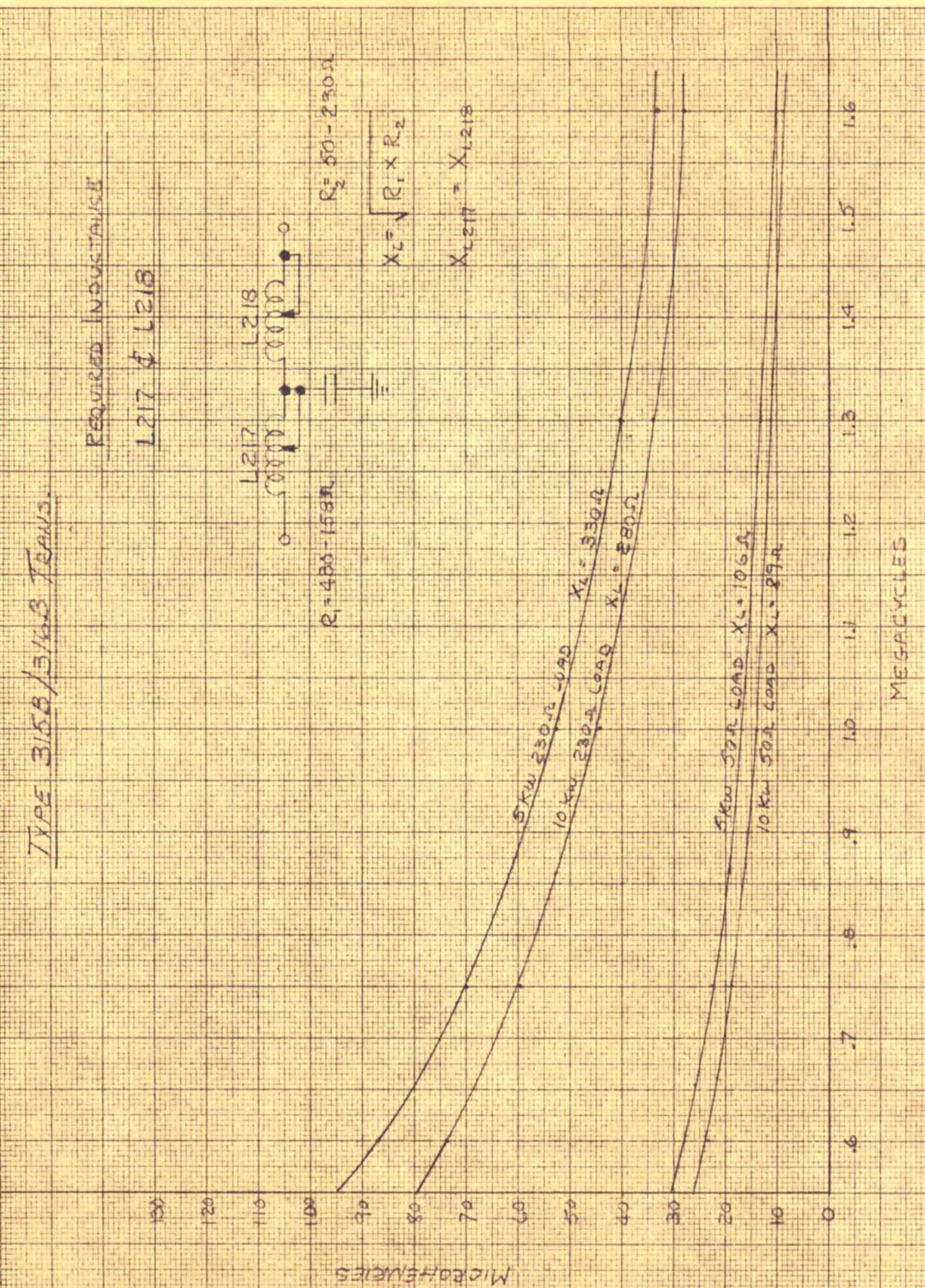

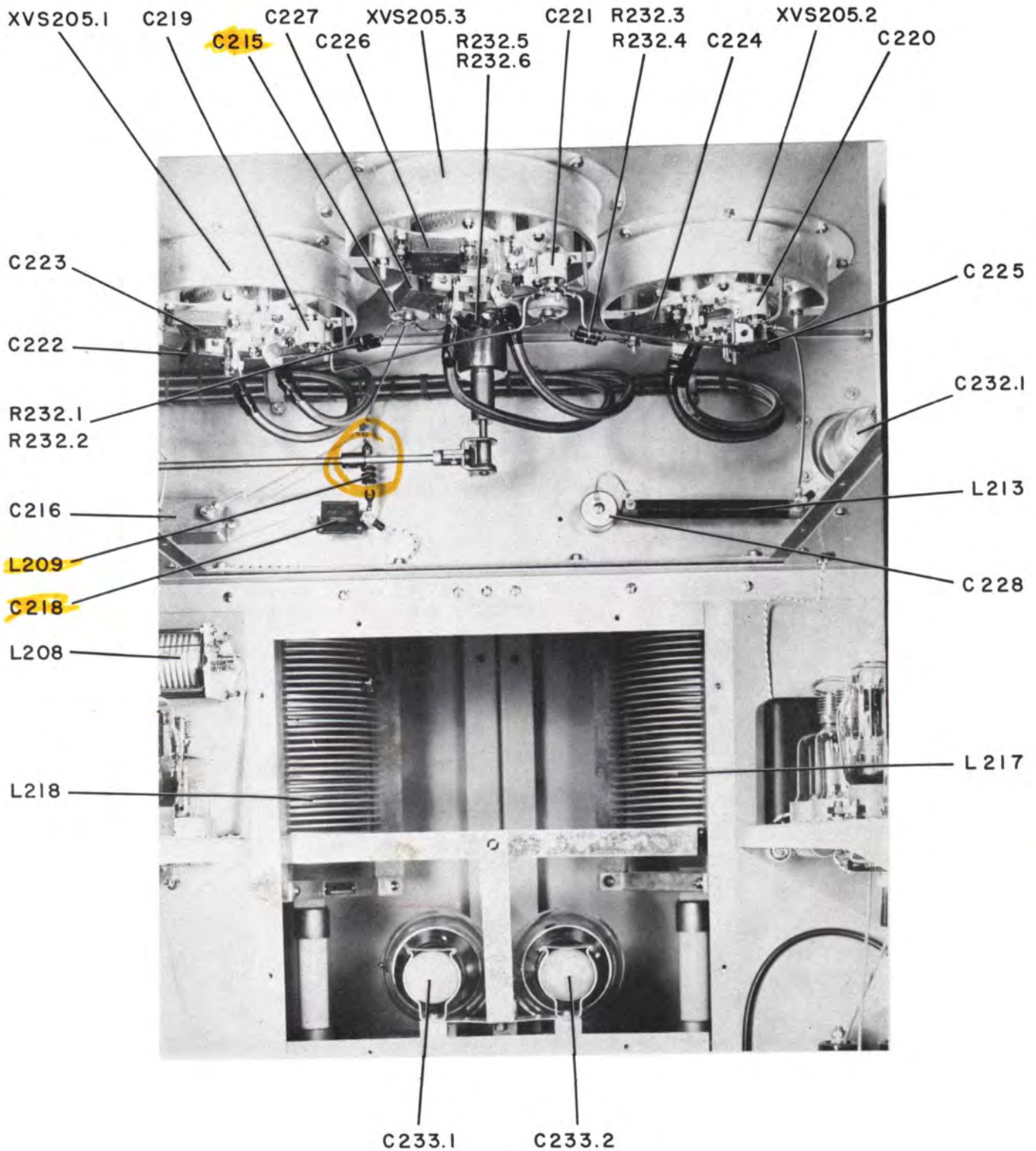

FIGURE 5-6
AMPLIFIER, UNDERSIDE OF P-A SHELF

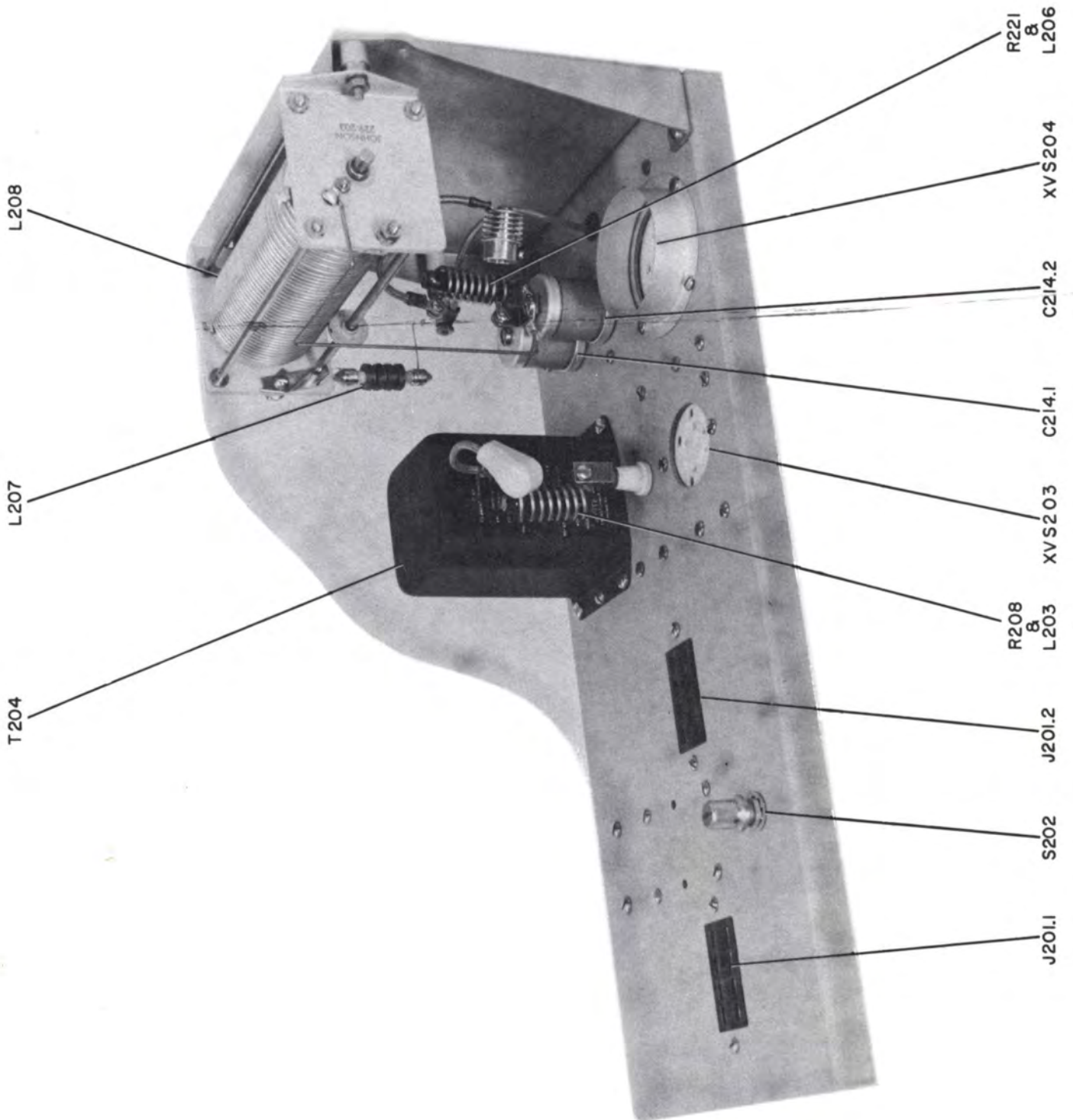

FIGURE 5-7
AMPLIFIER UNIT, RF DRIVER SHELF, TOP VIEW

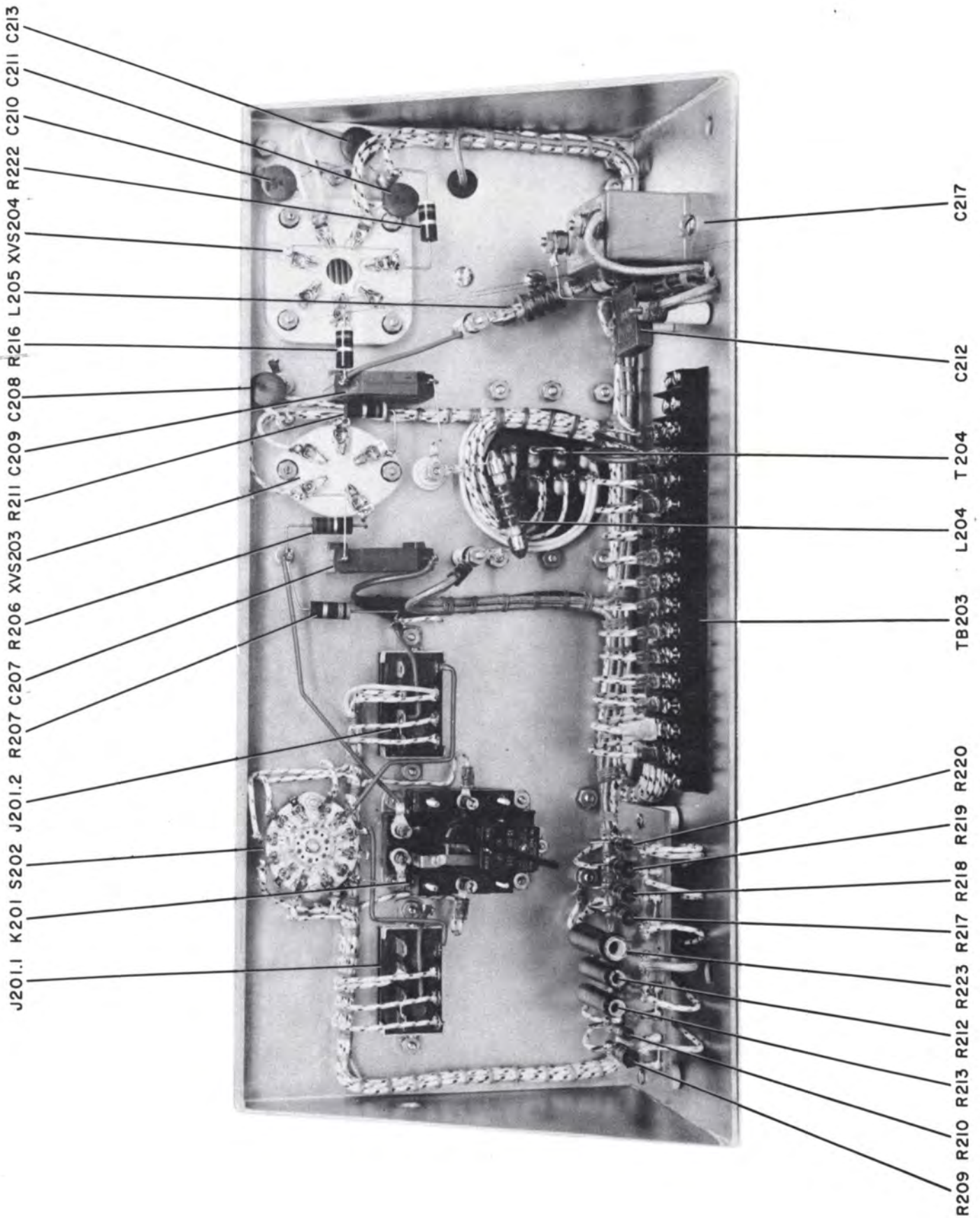

FIGURE 5-8
AMPLIFIER UNIT, UNDERSIDE OF RF DRIVER SHELF

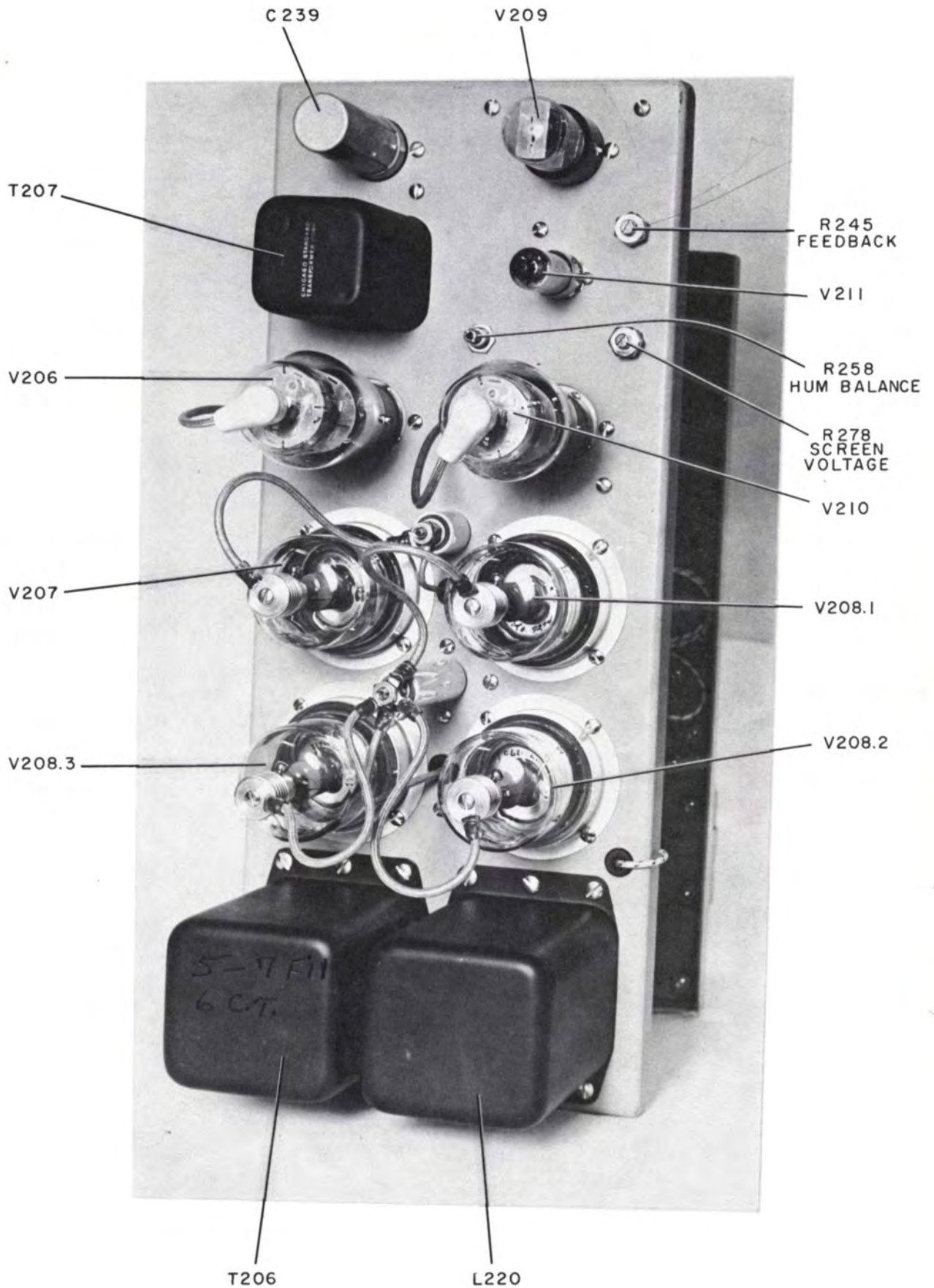

FIGURE 5-9
AMPLIFIER UNIT, MODULATOR SHELF, TOP VIEW

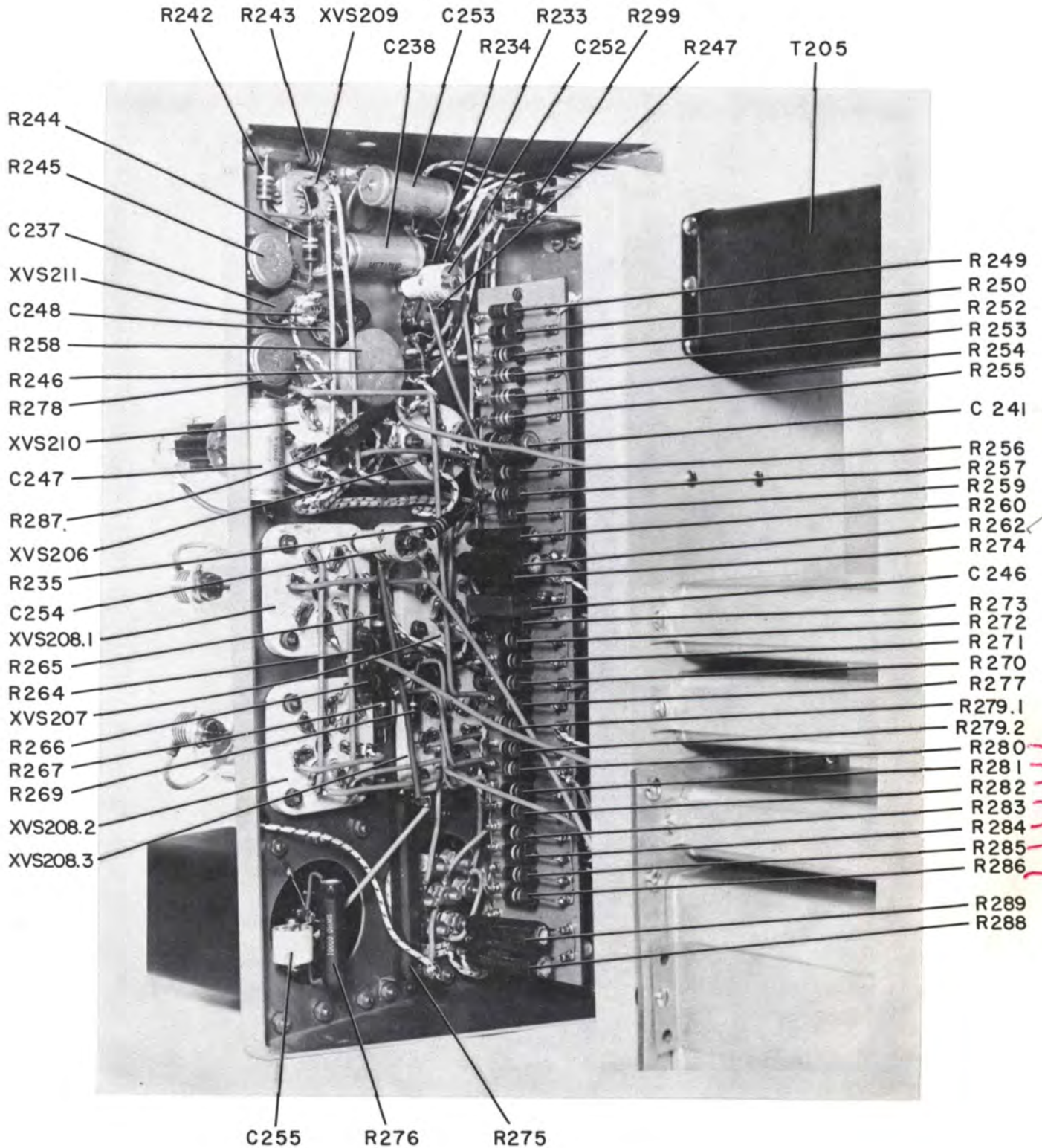

FIGURE 5-10
AMPLIFIER UNIT, UNDERSIDE OF MODULATOR SHELF

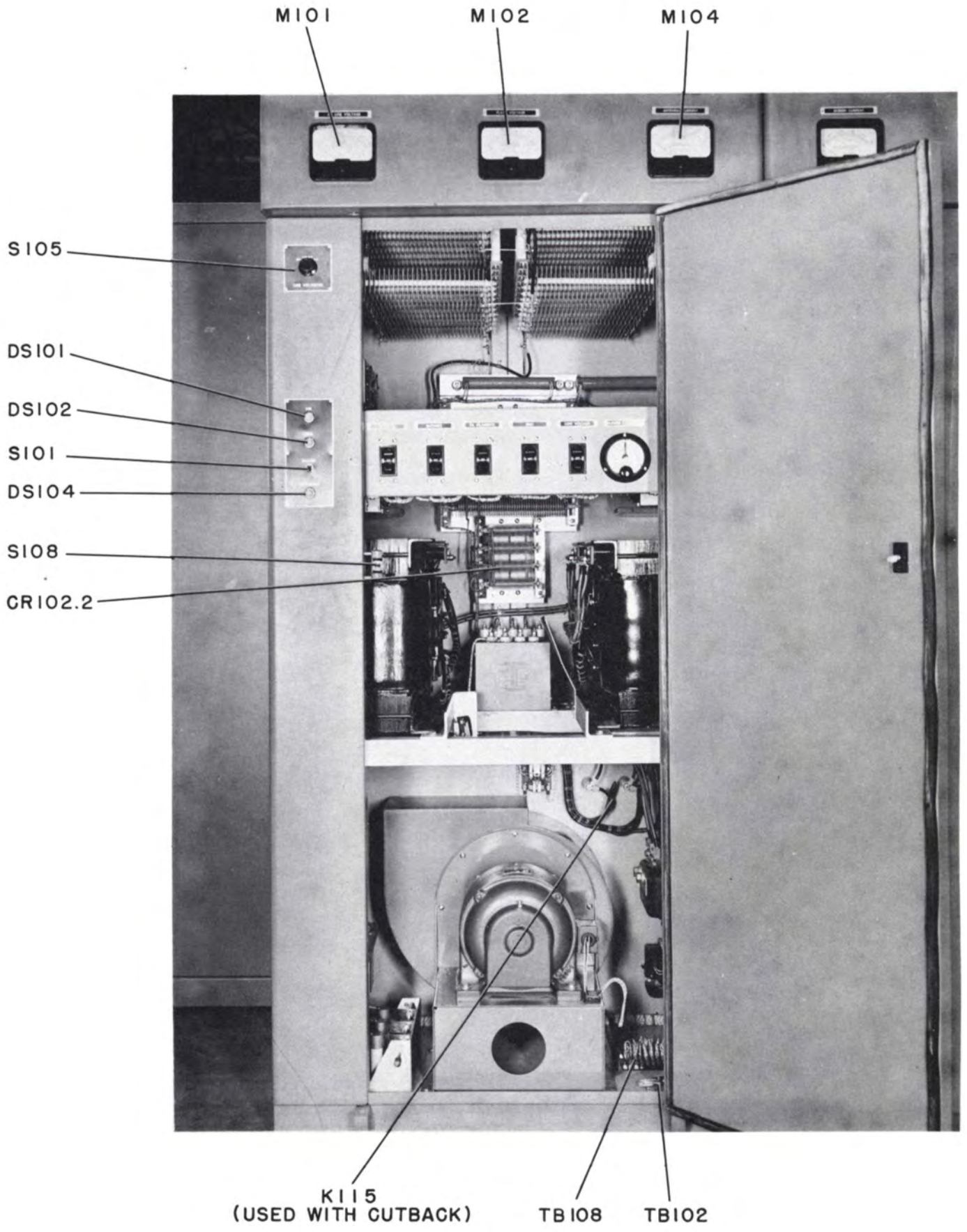

FIGURE 5-11
RECTIFIER-CONTROL UNIT, FRONT VIEW

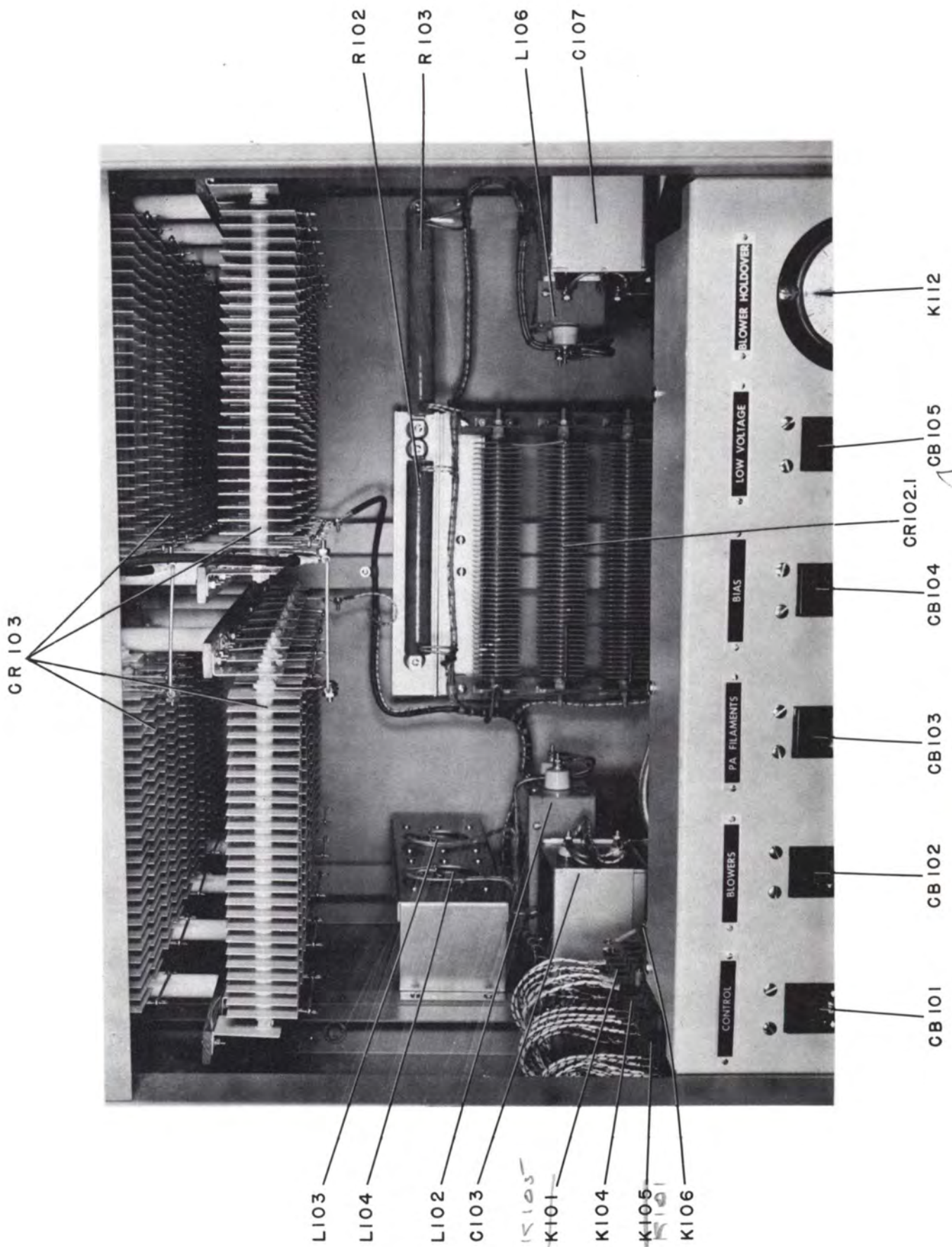

FIGURE 5-12
RECTIFIER-CONTROL UNIT, UPPER PORTION

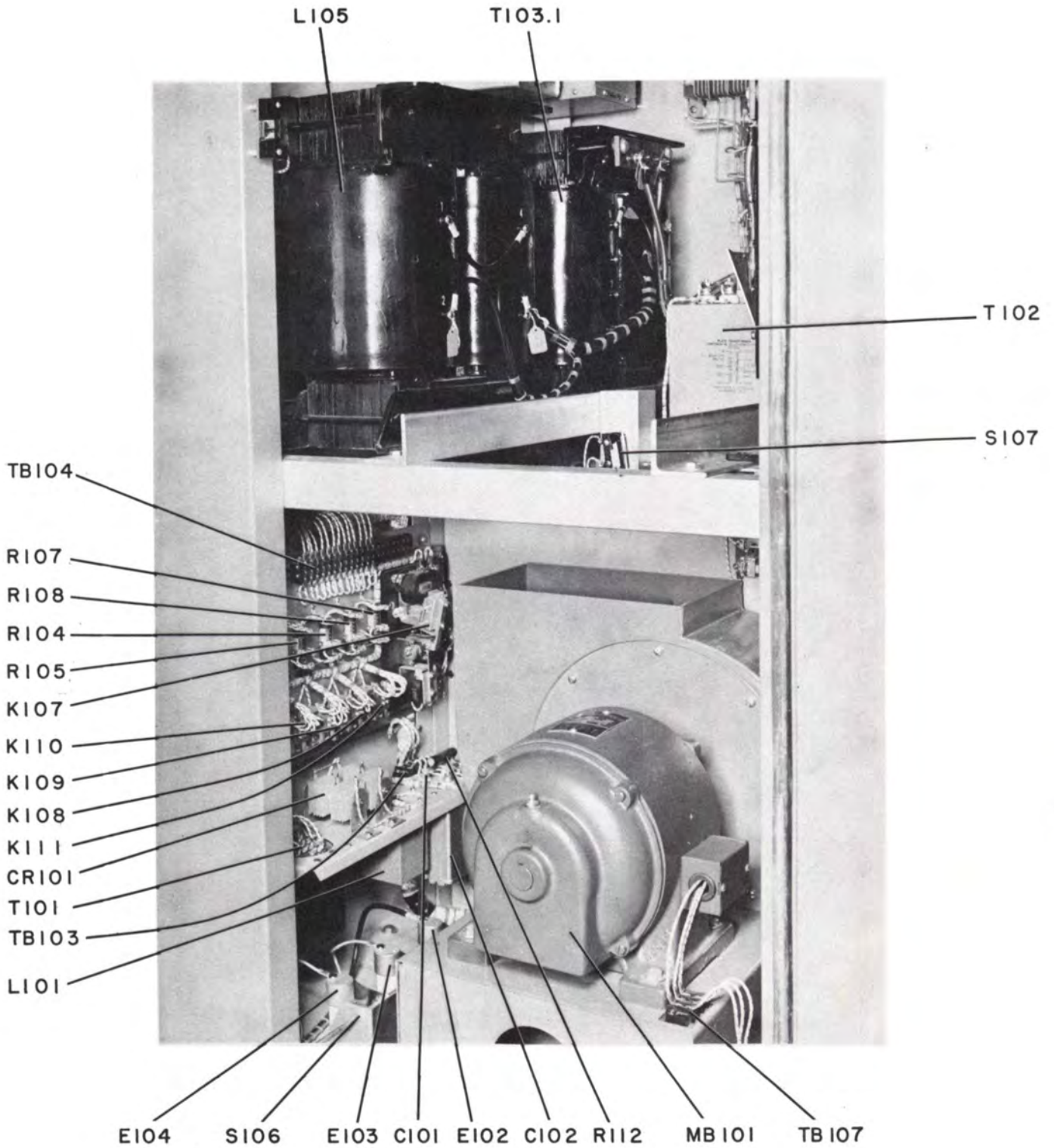

FIGURE 5-13
 RECTIFIER-CONTROL UNIT, LOWER LEFT SIDE

AIR DEFLECTOR

T103.2

T103.3

XF101
XF102
XF103
(HIDDEN)

K103

TP 1

TP 2

TP 3

TB105

K102

TB101

TB102

E101

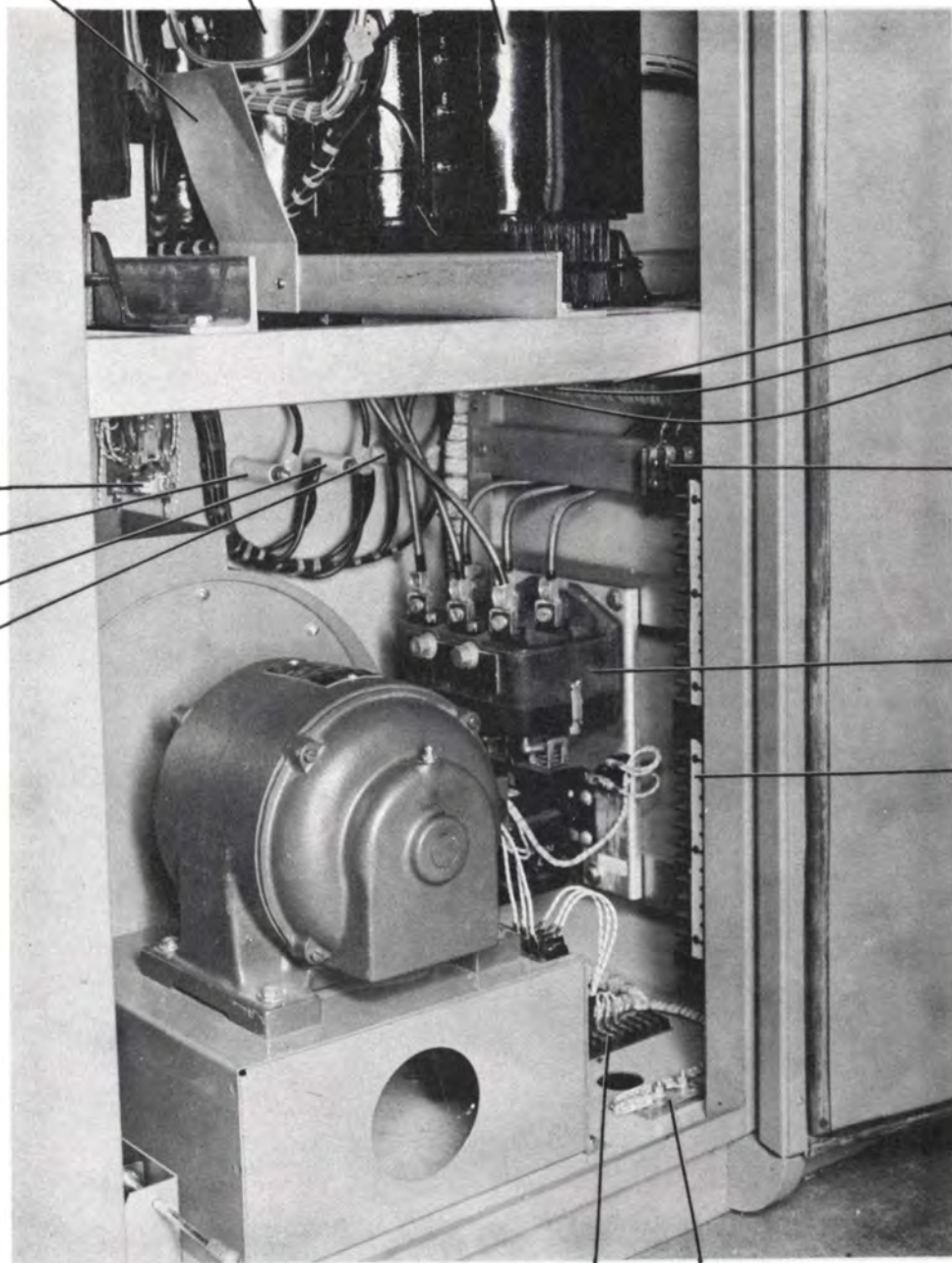
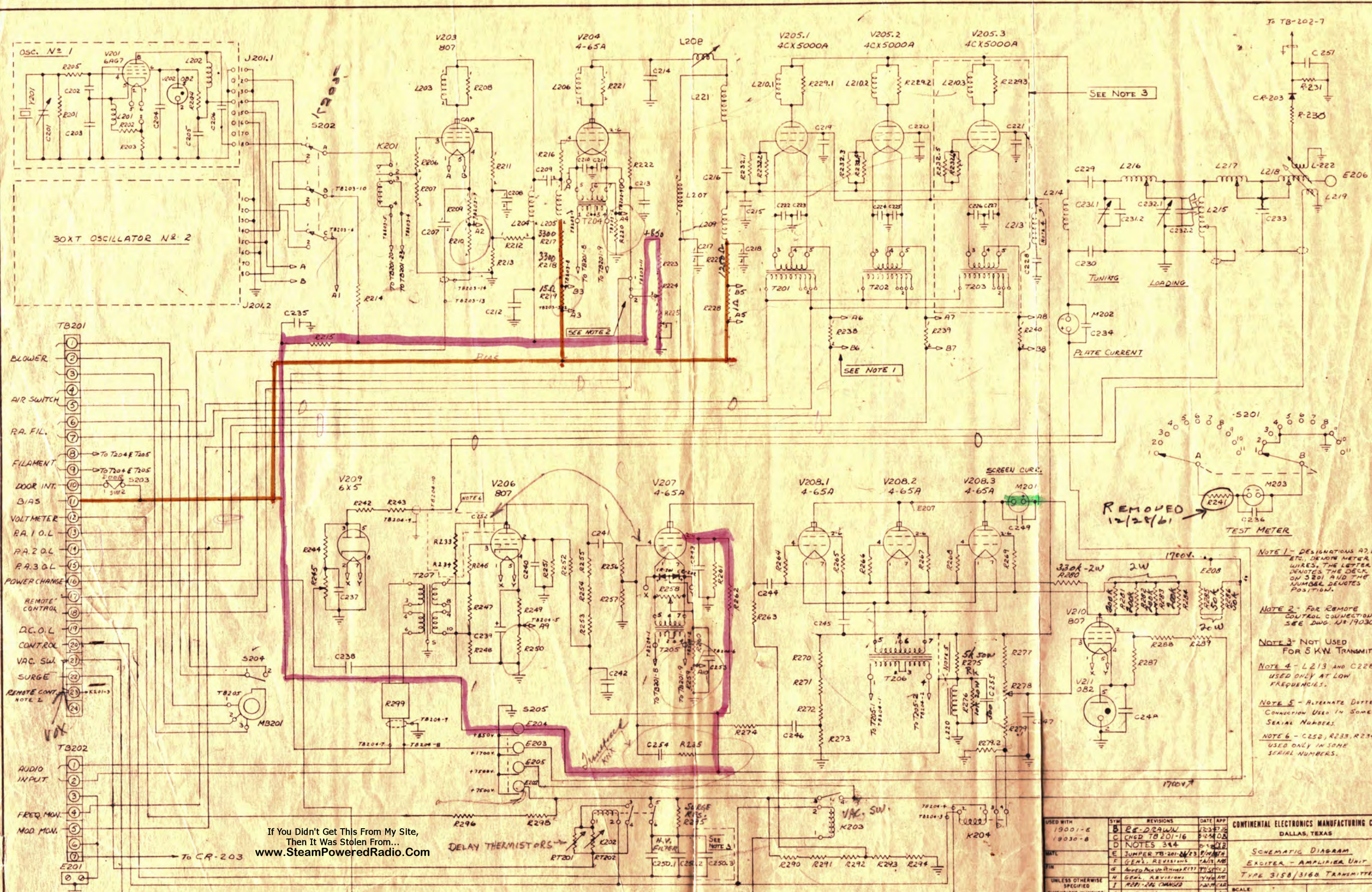

FIGURE 5-14
RECTIFIER-CONTROL UNIT, LOWER RIGHT SIDE



SEE NOTE 3

SEE NOTE 1

SEE NOTE 2

NOTE 1 - DESIGNATIONS A7, B7, ETC., DENOTE METER WIRES. THE LETTER DENOTES THE DECK ON 3801 AND THE NUMBER DENOTES POSITION.

NOTE 2 - FOR REMOTE CONTROL CONNECTIONS, SEE DWG. NR 19030-B

NOTE 3 - NOT USED FOR 5 KW TRANSMITTER

NOTE 4 - L213 AND C228 USED ONLY AT LOW FREQUENCIES.

NOTE 5 - ALTERNATE DOTTED CONNECTION USED IN SOME SERIAL NUMBERS.

NOTE 6 - C250, R233, R234 USED ONLY IN SOME SERIAL NUMBERS.

If You Didn't Get This From My Site, Then It Was Stolen From...
www.SteamPoweredRadio.Com

USED WITH		REVISIONS		DATE		APP	
19001-E	B	RE-DRAWN		12-28-61	J.S.		
19030-B	C	CHGD TB 201-16		5-24-62	J.S.		
	D	NOTES 3 & 4		5-24-62	J.S.		
	E	JUMPER TB-201-23		7-10-62	J.S.		
	F	GENL. REVISIONS		7-10-62	J.S.		
	G	ADDED METER WIRE		7-10-62	J.S.		
	H	GENL. REVISIONS		7-10-62	J.S.		
	I	R231-232 CHANGED		7-10-62	J.S.		
	J	GENL. CHG.		7-20-62	J.S.		

CONTINENTAL ELECTRONICS MANUFACTURING CO. DALLAS, TEXAS

SCHEMATIC DIAGRAM
EXCITER - AMPLIFIER UNIT
TYPE 315B/316A TRANSMITTER

SCALE: _____

APP'D: _____
ENR: MJB
J.S.
1902-E
12-3-57

These drawings and specifications are the property of CONTINENTAL ELECTRONICS MFG. CO., INC. of Dallas, Texas and shall not be reproduced, or copied or used as the basis for the manufacture or sale of apparatus without permission.

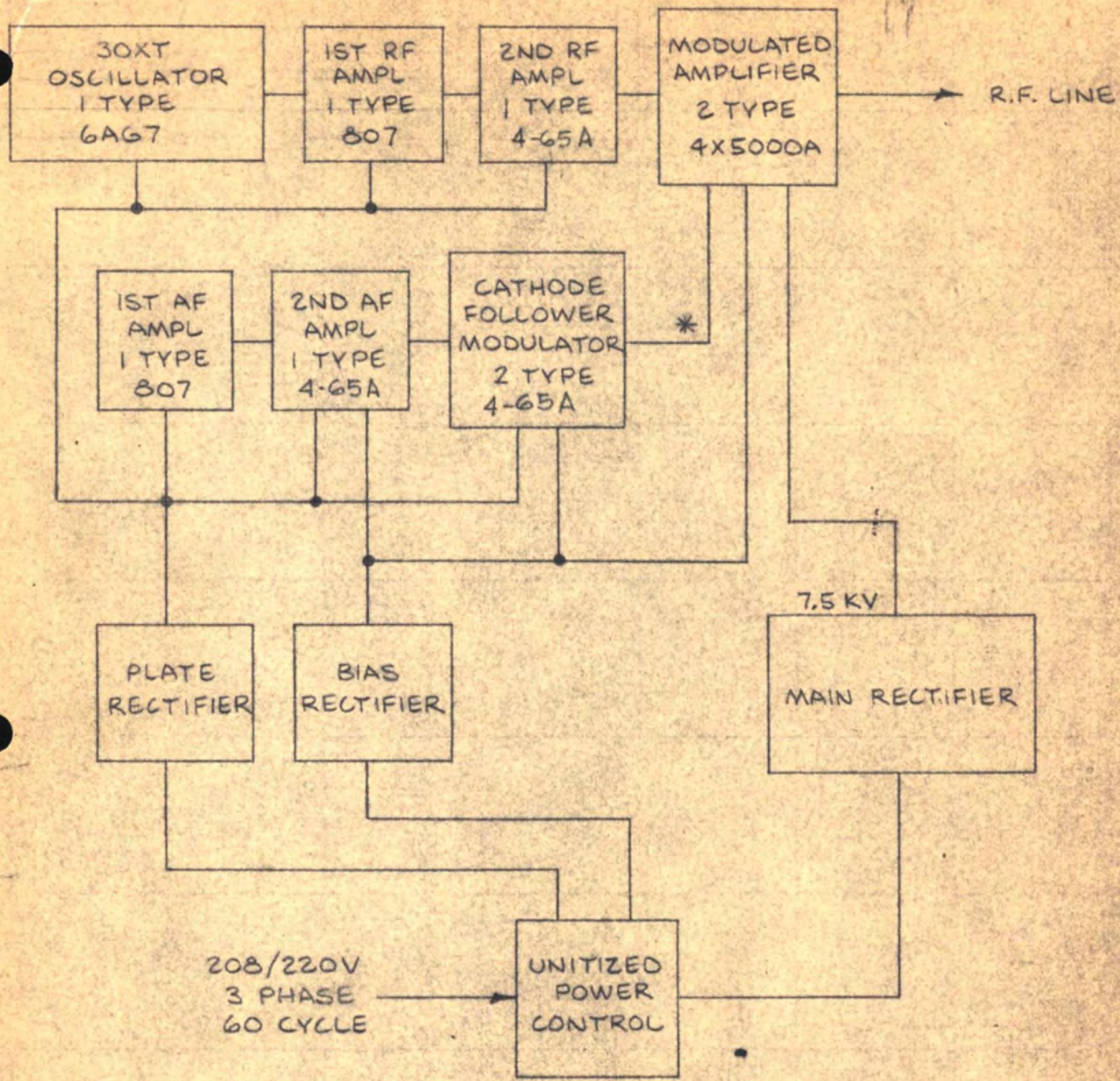

* -HIGH FIDELITY
(SCREEN MODULATION)

USED WITH:	ISSUE: 9-25-56	CONTINENTAL ELECTRONICS MANUFACTURING CO. DALLAS, TEXAS	
		BLOCK DIAGRAM TYPE 315B TRANSMITTER 5KW STANDARD BROADCAST	
		SCALE:	
	APP'D	ENG.	DRAWN BS 11235-A

CONTINENTAL ELECTRONICS MFG. CO.

SHEET 1
OF 10

TYPE 315B/316B Transmitter

ELECTRICAL PARTS LIST NO. 7428

UNIT Rectifier-Control Unit, Ser. Nos. 7, 15 & Above

REF. DWG. NO. 19001-E ENGR. JBS

SYMBOL	FUNCTION	NAME OF PART	DESCRIPTION	PART NO.	MANUFACTURER
C101	Bias Filter	Capacitor	10 mfd., 500 volts DC, dykanol filled, hermetically sealed with footed mounting brackets (2) No. 21535-14	TJL-6100	Cornell Dubilier
C102	Bias Filter	Capacitor	Same as C101		Cornell Dubilier
C103	4850V Filter	Capacitor	15 mfd., 1500 V DC (use 21535-29 brackets)	TJL-15150J	Cornell Dubilier
C104	4850V Filter	Capacitor	Same as C103		Cornell Dubilier
C105	Bypass	Capacitor	.01 mfd., 1000 DCWV, fixed, ceramic discap	DD-1032	Centralab
C106	Bypass	Capacitor	Same as C105		Centralab
C107	Filter	Capacitor	8 mfd., 2000 VDC, with footed mounting brackets (2) No. 21535-29	TJL-20080	Cornell Dubilier
C108	Filter	Capacitor	Same as C107		Cornell Dubilier

AUG 24 1959

www.SteamPoweredRadio.Com

CONTINENTAL ELECTRONICS MFG. CO.

www.SteamPoweredRadio.Com

SHEET 2
OF 10

TYPE 315B/316-B Transmitter

ELECTRICAL PARTS LIST NO. 7428

UNIT Rectifier-Control Unit, Ser. Nos. 7, 15 & Above

REF. DWG. NO. 19001-E

JBS

ENGR.

SYMBOL	FUNCTION	NAME OF PART	DESCRIPTION	PART NO.	MANUFACTURER
CB101	Control	Circuit Breaker	3 pole, curve 3, RC-5 amps., CC-5 amps., LC-0.5 ADC, Rated 240 volt AC	3096SK	Heinemann
CB102	Blower	Circuit Breaker	3 pole, curve 1, 7 amps. per pole rated 240 volts AC	3363S-7	Heinemann
CB103	P A Filament	Circuit Breaker	2 pole, curve 3, 20 amps. per pole, rated 240 volts AC	2263S-20	Heinemann
CB104	Bias	Circuit Breaker	Same as CB101		Heinemann
CB105	Low Voltage	Circuit Breaker	Same as CB101		Heinemann
CR101	Bias	Rectifier	Selenium rectifier (4 units)	RS-200	Bradley
CR102.1	Low Voltage	Rectifier	Selenium rectifier stack, 1.2 amps. DC, 1150 volts AC maximum (4 units)	SE11U46H688	Bradley
CR102.2	Low Voltage	Rectifier	Selenium rectifier (4 units)	SE11S34H700	Bradley
CR103	High Voltage	Rectifier	Selenium, HCD - Petti-Sel (60 units), per CEMC Spec. No. 10682, for Type 315B or Selenium, HCD - Petti-Sel (60 units), per CEMC Spec. No. 10683, for Type 316B	16F26H1H2G 25F26H1H2G	Radio Receptor Radio Receptor

AUG 24 1959

CONTINENTAL ELECTRONICS MFG. CO.

SHEET 3

OF 10

www.SteamPoweredRadio.Com

TYPE 315B/316B Transmitter

ELECTRICAL PARTS LIST NO. 7428

UNIT Rectifier-Control - Ser. Nos. 7, 15 & Above

REF. DWG. NO. 19001-E ENGR. JBS

SYMBOL	FUNCTION	NAME OF PART	DESCRIPTION	PART NO.	MANUFACTURER
DS101	Air	Lamp	Neon, T-3-1/4 miniature, bayonet base	NE-51	General Electric
DS102	Bias	Lamp	Same as DS101		General Electric
DS103	High Voltage Plate	Lamp	Same as DS101		General Electric
DS104	Filament	Lamp	Same as DS101		General Electric
DS105	Low Voltage	Lamp	Same as DS101		General Electric
DS106	High Power	Lamp	Same as DS101		General Electric
DS107	Low Power	Lamp	Same as DS101		General Electric
F101	Plate	Fuse	100 amperes, 250 V (for 316B) or 70 amperes, 250 V (for 315B)	FRN100 FRN 70	Buss Buss
F102	Plate	Fuse	Same as F101		Buss
F103	Plate	Fuse	Same as F101		Buss

AUG 24 1959

CONTINENTAL ELECTRONICS MFG. CO.

www.SteamPoweredRadio.Com

SHEET 4

OF 10

TYPE 315B/316B Transmitter

ELECTRICAL PARTS LIST NO. 7428

UNIT Rectifier-Control - Ser. Nos. 7, 15 & Above

REF. DWG. NO. 19001-E ENGR. JBS

SYMBOL	FUNCTION	NAME OF PART	DESCRIPTION	PART NO.	MANUFACTURER
K101	Main	Contactors	5 pole, 25 amperes, with 5 poles normally open, 115 volts, 60 cycle coil, with 10 amperes reversing contact kit	109110-101 45997-3	RBM RBM
K102	Plate	Contactors	Bulletin 7707, size 3, 3 pole, 100 amperes, 115 volts, 60 cycle coil, with 2 DPDT auxiliary contacts	77U33-16	Clark Controlle
K103	Power Change	Relay	Latching relay, mechanical lock in, electrical release, 115 VAC coils, DPDT, contacts rated at 15 A, 115 V	LE/2C/115VA	Advance
K104	Blower	Contactors	Same as K101		RBM
K105	P A Filament	Contactors	5 pole, 25 amperes, with all 5 poles normally open, 115 volts, 60 cycle coil	109119-101	RBM
K106	Low Voltage	Contactors	3 normally open contacts, rated 30 amperes AC, coil voltage 120 volts DC	A8CXX	Struthers Dunn
K107	Lockout	Relay	Electrical reset type sequence relay, step coil 115 volts, 60 cycle reset coil, 115 volts, 60 cycles, 2 load contacts normally closed	Type 99XXB101	Struthers Dunn
K108	Overload	Relay	1 normally open and 1 normally closed contact, 3 ohms, 250 ma DC coil	Type R-83-1904	Automatic Elec
K109	Overload	Relay	Same as K108		Automatic Elec
K110	Overload	Relay	Same as K108 (used in 316B only)		Automatic Ele
K111	Overload	Relay	Same as K108		Automatic Ele

AUG 24 1959

CONTINENTAL ELECTRONICS MFG. CO.

SHEET 5
OF 10

www.SteamPoweredRadio.Com

TYPE 315B/316B Transmitter ELECTRICAL PARTS LIST NO. 7428

UNIT Rectifier-Control - Ser. Nos. 7, 15 & Above REF. DWG. NO. 19001-E ENGR. JBS

SYMBOL	FUNCTION	NAME OF PART	DESCRIPTION	PART NO.	MANUFACTURER
K112	Hold-On	Relay	Delay relay, WD1123, 115 volts, 60 cycle coil	Type 412-120S	Cramer
K113	Time Delay	Relay	Plate supply, time delay (10 sec.)	B-2102	Edison
K114	Overload Reset	Relay	DPDT contacts, 110 volts DC coil (remote control only)	PS 11D	Potter Brumfield
K115	HV Transfer	Contactors	3 pole, double throw, 10 KV insulation, 115 V, 60 cy. coil, contacts rated at 10 amperes, 10 KV, AC (used in power cutback only)	CEMC Dwg. No. 19639-E	CEMC

CONTINENTAL ELECTRONICS MFG. CO.

www.SteamPoweredRadio.Com

SHEET 6
OF 10

TYPE 315B/316-B Transmitter

ELECTRICAL PARTS LIST NO. 7428

UNIT Rectifier-Control Unit, Ser. Nos. 7, 15 & Abdve

REF. DWG. NO. 19001-E ENGR. JBS

SYMBOL	FUNCTION	NAME OF PART	DESCRIPTION	PART NO.	MANUFACTURER
L101	Bias Filter	Inductor	8 henry at 160 ma DC, 1500 volts test	415K	ADC
L102	1700V Filter	Inductor	18 henry, 400 ma, 10 KV test	CS-15198	Thermador
L103	850V Filter	Inductor	12 henry at 200 ma., 2500 V. test	RS-12200	Chicago Trans.
L104	850V Filter	Inductor	Same as L103		Chicago Trans.
L105	High Voltage Filter	Inductor	Two reactors on common frame, each 7 henries at 1.8 amps., per CEMC Spec. No. 10696-B	CEMC Spec. No. 10696-B	Electro Engr.
L106	1700V Filter	Inductor	Same as L102		Thermador
M101	Line Voltage	Meter	AC voltmeter; 0-250 volts, 1000 ohms/volt	Series 55	Marion
M102	Plate Voltage	Meter	Milliamperemeter; 0-1 ma DC with scale marked 0-10 KVDC	Series 55	Marion
M103	Running Time	Meter	0 to 9,999.9 hours, 115 volts, 60 cycles AC	Type 631E	Cramer
M104	Rem. Ant. Curr.	Meter	0-200 microamps., with special scale marked in amperes, F.S. reading dependent upon customer antenna current	Series 55	Marion

AUG 24 1958

CONTINENTAL ELECTRONICS MFG. CO.

www.SteamPoweredRadio.Com

SHEET 7
OF 10

TYPE 315B/316B Transmitter

ELECTRICAL PARTS LIST NO. 7428

UNIT Rectifier-Control - Ser. Nos. 7, 15 & Above

REF. DWG. NO. 19001-E ENGR. JBS

SYMBOL	FUNCTION	NAME OF PART	D E S C R I P T I O N	PART NO	MANUFACTURER
MB101	Cooling	Blower	Model 1-3/4 utility fan, 1/2 hp, 208-220/440 volts, 3 phase, 60 cps., 2/1 ampere continuous duty, motor frame P203B, 850 RPM		Peerless
R101	Shunt	Resistor	10 ohms, 10 watts, fixed, wirewound	"Brown Devil"	Ohmite
R102	4850V Bleeder	Resistor	25,000 ohms, 160 watts, 8-1/2" L, D core, fixed, wirewound	160F	Ward Leonard
R103	4700V Bleeder	Resistor	50,000 ohms, 160 watts, 8-1/2" L, D core, fixed, wirewound	160F	Ward Leonard
R104	Shunt	Resistor	1 ohm, 25 watts, variable tap, wirewound, Dividohm	0360	Ohmite
R105	Shunt	Resistor	Same as R104		Ohmite
R106	Shunt	Resistor	Same as R104 (used in 316B only)		Ohmite
R107	Shunt	Resistor	1/2 ohm, consisting of two 1 ohm, 25 watt, variable tap, wirewound, Dividohm, connected in parallel		Ohmite
R108	R. C. Plate Curr.	Resistor	Same as R104		Ohmite
R109	R. C. Plate Volt.	Resistor	10,000 ohms, 2 watts, 10%, fixed, composition		Ohmite
R110	Calibrate	Resistor	3500 ohms, 1220A washer, 40K2 nut, 95T locknut	AR-8162	Chi. Tele.
R111	Time Delay Dropping	Resistor	1000 ohms, 10 watts, fixed		Ohmite
R112	Bias Bleeder	Resistor	1250 ohms, 20 watts, wirewound		Ohmite

AUG 24 1958

CONTINENTAL ELECTRONICS MFG. CO.

SHEET 8
OF 10

www.SteamPoweredRadio.Com

TYPE 315B/316B Transmitter

ELECTRICAL PARTS LIST NO. 7428

UNIT Rectifier-Control Unit, Ser. Nos. 7, 15 & Above

REF. DWG. NO. 19001-E ENGR. JBS

SYMBOL	FUNCTION	NAME OF PART	DESCRIPTION	PART NO.	MANUFACTURER
1101	Filament	Switch	DPDT, toggle, single hole mount	12TS11-3	Micro
1102	Plate	Switch	Same as S101		Micro
1103	O. L. Reset	Switch	Black button	2PB11	Micro
1104.1	High Power	Switch	Same as S103		Micro
1104.2	Low Power	Switch	Same as S103		Micro
1105	Meter	Switch	2 pole, 2-11 positions	2513	Centralab
1106	Grounding	Switch	Per CEMC Dwg. No.	19089-D	CEMC
1107	Air Interlock	Switch	Per CEMC Dwg. No.	5355-D BZ-2RW80	CEMC Micro
1108	Door Interlock	Switch	Two section door interlock	7460330-G4	General Electric
1109	Bias Supply	Transformer	Primary 115 volts; secondary #1: 120-140-160-180 at 150 ma DC; secondary #2, 5 volts at 3 amps.	1BS150	Chicago Trans.
11102	L. V. Plate	Transformer	Primary 220-230-240 volts, 50/60 cps; secondary, 1690-968-0-968-1690 volts at 750 ma DC	CEMC Spec. No. 10597 CS6461	Thermador
11103.1	H. V. Plate	Transformer	Primary 208/230 volts, 50/60 cps. AC; secondary 2950-4440-5900, 9.1 kva, per CEMC Spec. #10685-C (T103.1 used in 316B only)	CEMC Spec. No. 10685-C	Electro Engr.

AUG 24 1954

CONTINENTAL ELECTRONICS MFG. CO.

SHEET 9
OF 10

www.SteamPoweredRadio.Com

TYPE 315B/316-B Transmitter

ELECTRICAL PARTS LIST NO. 7428

UNIT Rectifier-Control Unit, Ser. Nos. 7, 15 & Above

REF. DWG. NO. 19001-E

ENGR. JBS

SYMBOL	FUNCTION	NAME OF PART	DESCRIPTION	PART NO.	MANUFACTURER
103.2	H.V. Plate	Transformer	Same as T103.1		Electro Engr.
103.3	H.V. Plate	Transformer	Same as T103.1		Electro Engr.
TB101	Terminal	Strip	12 terminal blocks (2 required)	6012-12	Burke
TB102	Terminal	Strip	Size 141 barrier, 15 terminals, with backing strip	15-141	Cinch Jones
TB103	Terminal	Strip	Size 141 barrier, 4 terminals, with backing strip	4-141	Cinch Jones
TB104	Terminal	Strip	Size 141 barrier, 20 terminals, with backing strip	20-141	Cinch Jones
TB105	Terminal	Strip	Size 151 barrier, 3 terminals, with backing strip	3-151	Cinch Jones
TB106	Terminal	Strip	12 terminal blocks (used with 317B trans. only)	6012-12	Burke
TB107	Terminal	Strip	Size 141 barrier, 3 terminals, with backing strip	3-141	Cinch Jones
TB108	Terminal	Strip	Same as TB102		Cinch Jones

AUG 24 1958

CONTINENTAL ELECTRONICS MFG. CO.

SHEET 10
OF 10

www.SteamPoweredRadio.Com

TYPE 315B/316-B Transmitter

ELECTRICAL PARTS LIST NO. 7428

UNIT

Rectifier-Control Unit, Ser. Nos. 7, 15 & Above

REF. DWG. NO. 19001-E ENGR.

JBS

SYMBOL	FUNCTION	NAME OF PART	DESCRIPTION	PART NO.	MANUFACTURER
XDS101	Air Indicator	Lamp Assembly	Pilot lamp assembly including 100,000 ohm resistor and white lens	147-408-6	E. F. Johnson
XDS102	Bias Indicator	Lamp Assembly	Same as XDS101		E. F. Johnson
XCS103	High Voltage Plate Indicator	Lamp Assembly	Pilot lamp assembly including 100,000 ohm resistor and red lens	147-408-2	E. F. Johnson
XDS104	Filament Indicator	Lamp Assembly	Same as XDS101 (except use 270 K ohm 1/2 watt resistor)		E. F. Johnson
XDS105	Low Voltage Indicator	Lamp Assembly	Same as XDS101 (except use 270 K ohm, 1/2 watt resistor)		E. F. Johnson
XXDS106	High Power Indicator	Lamp Assy	Same as XDS101		EF Johnson
XXDS107	Low Power Indicator	Lamp Assy	Same as XDS101		E. F. Johnson
XXKS101	Relay	Socket	8 pin octal	335 P H TS101P01	Elco
XF101	Plate	Fuseholder	61-100 amperes, 250 V, single pole	1931	Bryant
XF102	Plate	Fuseholder	Same as XF101		Bryant
XF103	Plate	Fuseholder	Same as XF101		Bryant

CONTINENTAL ELECTRONICS MFG. CO.

SHEET 1
OF 21

www.SteamPoweredRadio.Com

TYPE 315B/316B Transmitter ELECTRICAL PARTS LIST NO. 7429
 UNIT Exciter-Amplifier REF. DWG. NO. 19002-E ENGR. JBS

SYMBOL	FUNCTION	NAME OF PART	D E S C R I P T I O N	PART NO.	MANUFACTURER
C201 thru C206		Capacitor	In 30XT oscillator		
C207	Coupling	Capacitor	Faradon type NF, .0005 mfd., 2500 WVDC	Type NF	Cornell Dubilie
C208	Screen Bypass	Capacitor	.01 mfd., 1000 VDC, fixed, ceramic discap	DD-1032	Centralab
C209	Coupling	Capacitor	Faradon type NF, .0001 mfd., 2500 WVDC	Type NF	Cornell Dubilie
C210	Bypass	Capacitor	Same as C208		Centralab
C211	Bypass	Capacitor	Same as C208		Centralab
C212	Bypass	Capacitor	.01 mfd., 1200 WVDC, fixed, mica	4LS-11010	Cornell Dubilie
C213	Bypass	Capacitor	Same as C208		Centralab
C214	Tuning	Capacitor	200 mmfd., 7.5 kv, fixed, ceramic (depending on frequency)	851-200N	Centralab
C215	Loading	Capacitor	Same as C214		Centralab
C216	Blocking	Capacitor	.002 mfd., 5000 volts, fixed, mica	3381-6L	Cornell Dubilie
C217	Bypass	Capacitor	.01 mfd., 2000 volts, fixed, mica	151-6L	Cornell Dubilie
C218	Bypass	Capacitor	Same as C212		Cornell Dubilie
C219	Bypass	Capacitor	500 mmfd., 7500 VDC, fixed, ceramic (50 mmfd., 7500 VDC used when C228 & L213 are used)	858S-500 (850S-50N)	Centralab

CONTINENTAL ELECTRONICS MFG. CO.

www.SteamPoweredRadio.Com

SHEET 2
OF 21

TYPE 315B/316B Transmitter

ELECTRICAL PARTS LIST NO. 7429

UNIT Exciter-Amplifier Unit

REF. DWG. NO. 19002-E ENGR. JBS

SYMBOL	FUNCTION	NAME OF PART	D E S C R I P T I O N	PART NO.	MANUFACTURER
C220	Bypass	Capacitor	Same as C219		Centralab
C221	Bypass	Capacitor	Same as C219 (used in 316B only)		Cantralab
C222	Bypass	Capacitor	.01 mfd., 2500 WVDC, fixed, mica	4LS-21010	Cornell Dubilier
C223	Bypass	Capacitor	Same as C222		Cornell Dubilier
C224	Bypass	Capacitor	Same as C222		Cornell Dubilier
C225	Bypass	Capacitor	Same as C222		Cornell Dubilier
C226	Bypass	Capacitor	Same as C222 (used in 316B only)		Cornell Dubilier
C227	Bypass	Capacitor	Same as C222 (used in 316B only)		Cornell Dubilier
C228	Bypass	Capacitor	Same as C214 (depending on frequency) (Not used in Ser. Nos. 8, 9, 13, and above)		Centralab
C229	Blocking	Capacitor	.0043 mfd., 12 kv.	Type 2583-51	Cornell Dubilier
C230	Blocking	Capacitor	Same as C229		Cornell Dubilier
231.1	Tuning	Capacitor	25-1000 mmfd., 25 KV, vacuum, variable	UCSX 25-1000	Jennings
231.2	Padding	Capacitor	Type M-500, M-750, M-1000 or combinations, depending on frequency	UCSX	Jennings
C232.1	Loading	Capacitor	Same as C231.1		Jennings
C232.2	Padding	Capacitor	Same as C231.2		Jennings

CONTINENTAL ELECTRONICS MFG. CO.

www.SteamPoweredRadio.Com

SHEET 3
OF 21

TYPE 315B/316B Transmitter

ELECTRICAL PARTS LIST NO. 7429

UNIT Exciter-Amplifier Unit

REF. DWG. NO. 19002-E

JBS

ENGR.

SYMBOL	FUNCTION	NAME OF PART	DESCRIPTION	PART NO.	MANUFACTURER
C233.1	Network	Capacitor	Same as C231.2		Jennings
C233.2	Padding	Capacitor	Same as C231.2		Jennings
C234	Bypass	Capacitor	Same as C208		Centralab
C235	Bypass	Capacitor	Same as C222		Cornell Dubilie
C236	Bypass	Capacitor	Same as C208		Centralab
C237	Bypass	Capacitor	.0001 mfd., 500 volts, fixed, silver, mica	5R5-T1	Cornell Dubilie
C238	Coupling	Capacitor	4 mfd., 150 V DC, Meta-pup	MTM-1W4	Cornell Dubilie
C239	Bypass	Capacitor	11 mfd., 400 volts, type "FP"	850188	Magnavox
C240	Bypass	Capacitor	10 mfd., 600 V DC, dykanol-filled, with footed mounting brackets #21535-14 (2)	TJL-6100	Cornell Dubilie
C241	Coupling	Capacitor	.03 mfd., 600 V DC	CUB-6S3	Cornell Dubilie
C242	Bypass	Capacitor	Same as C222		Cornell Dubilie
C243	Bypass	Capacitor	Same as C240		Cornell Dubilie
C244	Coupling	Capacitor	.25 mfd., 7500 V \pm 10%, with footed mounting brackets CP07FE3	CP70DIFR254K	Cornell Dubilie
C245	Coupling	Capacitor	Same as C240		Cornell Dubilie
C246	Coupling	Capacitor	.005 mmfd., 2500 V DC, fixed, mica	4LS	Cornell Dubilie

CONTINENTAL ELECTRONICS MFG. CO.

SHEET 4
OF 21

www.SteamPoweredRadio.Com

TYPE 315B/316B Transmitter

ELECTRICAL PARTS LIST NO. 7429

UNIT Exciter-Amplifier Unit

REF. DWG. NO. 19002-E ENGR. JBS

SYMBOL	FUNCTION	NAME OF PART	DESCRIPTION	PART NO.	MANUFACTURER
C247	Bypass	Capacitor	Same as C238		Cornell Dubillie
C248	Bypass	Capacitor	.25 mfd., 600 V.	MP6P25	Cornell Dubillie
C249	Bypass	Capacitor	Same as C208		Centralab
C250.1	Filter	Capacitor	6 mfd., 7500 V DC	TK-70060G	Cornell Dubillie
C250.2	Filter	Capacitor	Same as C250.1		Cornell Dubillie
C250.3	Filter	Capacitor	Same as C250.1 (used in 316B ^o only)		Cornell Dubillie
C251	Remote Antenna Meter	Capacitor	Same as C208		Cornell Dubillie
C252	Feedback	Capacitor	500 mmfd., 5000 WVDC, fixed, ceramic (used only in some serial numbers)	858S-500	Centralab
C253	Bypass	Capacitor	2 mfd., 150 VDC, Meta-pup	MTM-1W2	Cornell Dubillie
C254	Coupling	Capacitor	25 mmfd., 7500 WVDC, fixed, ceramic	850S-25Z	Centralab
C255	Bypass	Capacitor	Same as C252 (used only in some serial numbers)		Centralab

CONTINENTAL ELECTRONICS MFG. CO.

www.SteamPoweredRadio.Com

SHEET 5
OF 21

TYPE 315B/316B Transmitter

ELECTRICAL PARTS LIST NO. 7429

UNIT Exciter - Amplifier Unit

REF. DWG. NO. 19002-E ENGR. JBS

SYMBOL	FUNCTION	NAME OF PART	DESCRIPTION	PART NO.	MANUFACTURER
CR201	Cathode	Rectifier	Selenium, 1/2 wave, rated 65 ma DC, 1300 volts RMS	RS65	Bradley
CR202	Cathode	Rectifier	Same as CR201		Bradley
CR203	Remote Antenna Meter	Rectifier	Crystal diode	1N48	General Electric
DS201	Regular	Lamp	Neon bulb (used only for Conelrad switching)	NE-51	General Electric
DS202	Conelrad	Lamp	Same as DS201 (used only for Conelrad switching)		General Electric
J201.1	Oscillator	Receptacle	8 pin		Cinch Jones
J201.2	Oscillator	Receptacle	Same as J201.1	S-408-AB	Cinch Jones

CONTINENTAL ELECTRONICS MFG. CO.

www.SteamPoweredRadio.Com

SHEET 6
OF 21

TYPE 315B/316B Transmitter

ELECTRICAL PARTS LIST NO. 7429

UNIT Exciter-Amplifier

REF. DWG. NO. 19002-E

JBS

ENGR.

SYMBOL	FUNCTION	NAME OF PART	DESCRIPTION	PART NO.	MANUFACTURER
K201	Excitation	Relay	Single pole, normally open, 115 volts, 60 cy.coil	B1AXX	Struthers Dunn
K202	Surge	Contactora	2 pole, double break, with 115 volts, 60 cy. coil	RC-5620	Monitor Control
K203	Vacuum Switch	Contactora	Switch with type EO solenoid, 115 volts, 60 cy.coil	RIG	Jennings
K204	Screen	Relay	Same as K201		Struthers Dunn
K205.1	Oscillator Switching	Relay	115 V, 60 cps. coil, DPDT contacts, RF (used only for Conelrad switching)	AM/2C/115VA	Advance
K205.2	Oscillator Switching	Relay	Same as K205.1		Advance
K206	Driver Tuning	Relay	115 V, 60 cps. coil, DPDT contacts, RF (used only for Conelrad switching)	AH/2C/115VA	Advance
K207	Output Tuning	Relay	RF contactor, DTD with 4 auxiliary switches, operating solenoids for 115 volts, 60 cps. (used only for Conelrad switching)	145-102-2	E. F. Johnson
K208	Not Used		Not Used		
K209	RF Drive	Relay	SPST, NC, 115 VAC coil (used only on power cutback)	B1XXA	Struthers Dunn
K210	Audio	Relay	DPDT, 2 NO and 2 NC contacts, 115 V AC coil (used only on power cutback)	R-83	Automatic Elec.
K211	Excitation	Relay	DPDT, 115 V AC coil (remote control special application only)	PS11A	Potter Brumfield

CONTINENTAL ELECTRONICS MFG. CO.

SHEET 7
OF 21

www.SteamPoweredRadio.Com

TYPE 315B/316B Transmitter

ELECTRICAL PARTS LIST NO. 7429

UNIT Exciter-Amplifier

REF. DWG. NO. 19002-E

JBS

ENGR.

SYMBOL	FUNCTION	NAME OF PART	DESCRIPTION	PART NO.	MANUFACTURER
L201 and L202		Inductor	In 30 XT oscillator		
L203	Trap	Inductor	Part of R208	R-100	Ohmite
L204	Plate RFC	Inductor	2.5 millihenry, 125 ma, RF choke		National
L205	Grid RFC	Inductor	Same as L204		National
L206	Trap	Inductor	Part of R221		Ohmite
L207	RFC	Inductor	Same as L204		National
L208	Plate	Inductor	25 microhenries, 3 amperes, variable	220-203	E. F. Johnson
L209	RFC	Inductor	Same as L204		National
L210.1	Trap	Inductor	Part of R229.1, per CEMC Dwg. No.	19222-B	CEMC
L210.2	Trap	Inductor	Part of R229.2, per CEMC Dwg. No.	19222-B	CEMC
L210.3	Trap	Inductor	Part of R229.3, per CEMC Dwg. No. (used in 316B only)	19222-B	CEMC
L211	Not Used		Not Used		
L212	Not Used		Not Used		
L213	Screen	Inductor	Per CEMC Dwg. No. (Not used in Ser. Nos. 8, 9, 13, and above)	19247-A	CEMC

CONTINENTAL ELECTRONICS MFG. CO.

www.SteamPoweredRadio.Com

SHEET 8
OF 21

TYPE 315B/316B Transmitter

ELECTRICAL PARTS LIST NO. 7429

UNIT Exciter-Amplifier

REF. DWG. NO. 19002-E ENGR. JBS

SYMBOL	FUNCTION	NAME OF PART	DESCRIPTION		PART NO.	MANUFACTURER
L214	Plate	Inductor	Per CEMC Dwg. No.		19197-D	CEMC
L215	Choke	Inductor	Per CEMC Dwg. No.		19199-D	CEMC
L216	Plate	Inductor	NOTE: Coil is to be determined by frequency used, 30 microhenries, 40 amperes, 1/2" tubing		202-602 41410NT14	E. F. Johnson
			Coil clip RC8-1/2"		235-828	E. F. Johnson
			64 microhenries, 30 amperes, 3/8" tubing		202-502 32410NT12	E. F. Johnson
			Coil clip RC6-3/8"		235-826	E. F. Johnson
L217	Network	Inductor	NOTE: Coil is to be determined by frequency used, 78 microhenries, 20 amperes, 1/2" x .09"		200-302 4346N5	E. F. Johnson
			Coil clip LC8-1/2" x .09"		235-808	E. F. Johnson
			50 microhenries, 20 amperes, 1/2" x .09"		200-303	E. F. Johnson
			Coil clip LC8-1/2" x .09"		235-808	E. F. Johnson
L218	Network	Inductor	Same as L217 (changes w/freq.)			E. F. Johnson
L219	Feedback	Inductor	Per CEMC Dwg. No.		19247-A	CEMC
L220	Cathode	Inductor	12 henries, 150 ma		RS12150	Chicago Trans.
L221	Plate	Inductor	Per CEMC Dwg. No.		19510-D	CEMC
L222	Remote Antenna Meter Pickup	Inductor	Per CEMC Dwg. No.		19226-A	CEMC

5-24/11

CONTINENTAL ELECTRONICS MFG. CO.

SHEET 9
OF 21

www.SteamPoweredRadio.Com

TYPE 315B/316B Transmitter

ELECTRICAL PARTS LIST NO. 7429

UNIT Exciter-Amplifier

REF. DWG. NO. 19002-E ENGR. JBS

SYMBOL	FUNCTION	NAME OF PART	DESCRIPTION	PART NO.	MANUFACTURER
M201	Screen Current	Meter	0-500 milliamperes DC, with extra meter case, face only	Series "55"	Marion
M202	Plate Current	Meter	0-5 amperes DC, with extra meter case, face only	Series "55"	Marion
M203	Test	Meter	0-200 microamperes, with scale marked 0-120% of normal SIMPSON MODEL 29 20048, 1000 μ V - 0-20 M A scale	Series "55"	Marion
MB201	Cooling	Blower	Model 1-1/2 high speed utility blower, 3/4 HP, 1450/1750 RPM, 208-220/440 volts, 50/60 cycles, 3-phase, 3/1.5 ampere frame PW66B		Peerless

CONTINENTAL ELECTRONICS MFG. CO.

SHEET 10
OF 21

www.SteamPoweredRadio.Com

TYPE315B/316B Transmitter

ELECTRICAL PARTS LIST NO. 7429

UNIT Exciter-Amplifier Unit

REF. DWG. NO. 19002-E ENGR. JBS

SYMBOL	FUNCTION	NAME OF PART	DESCRIPTION	PART NO.	MANUFACTURER
RR201 thru RR205		Resistor	In 30XT Oscillator		
RR206	Stabilizing	Resistor	120 ohms, 2 watts, $\pm 10\%$, fixed, composition		Ohmite
RR207	Grid Leak	Resistor	3300 ohms, 2 watts, $\pm 10\%$, fixed, composition		Ohmite
RR208	Trap	Resistor	Parasitic trap	P-300	Ohmite
RR209	Cathode	Resistor	330 ohms, 2 watts, $\pm 10\%$, fixed, composition		Ohmite
RR210	Meter	Resistor	1.2 $\pm 1\%$ - 1KC - TYPE WW4 2.7 ohms, 1 watt, $\pm 10\%$, fixed, composition		Ohmite
RR211	Stabilizing	Resistor	47 ohms, 2 watts, $\pm 10\%$, fixed, composition		Ohmite
RR212	Screen	Resistor	25,000 ohms, 10 watts, fixed, wirewound	"Brown Devil"	Ohmite
RR213	Screen	Resistor	Same as R212		Ohmite
RR214	Dropping	Resistor	7500 ohms, 20 watts, fixed, wirewound	"Brown Devil"	Ohmite
RR215	Dropping	Resistor	5000 ohms, 50 watts, fixed, wirewound	0411	Ohmite
RR216	Stabilizing	Resistor	Same as R211		Ohmite
RR217	Grid Leak	Resistor	Same as R207		Ohmite
RR218	Grid Leak	Resistor	Same as R207		Ohmite
RR219	Meter	Resistor	15 ohms, 2 watts, $\pm 10\%$, fixed, composition 10 ohms, 2 watts $\pm 5\%$		Ohmite

CONTINENTAL ELECTRONICS MFG. CO.

SHEET 11
OF 21

www.SteamPoweredRadio.Com

TYPE 315B/316B Transmitter ELECTRICAL PARTS LIST NO. 7429

UNIT Exciter-Amplifier Unit REF. DWG. NO. 19002-E ENGR. JBS

SYMBOL	FUNCTION	NAME OF PART	D E S C R I P T I O N	PART NO.	MANUFACTURER
R220	Meter	Resistor	Same as R210		Ohmite
R221	Trap	Resistor	Same as R208		Ohmite
R222	Stabilizing	Resistor	Same as R211		Ohmite
R223	Screen	Resistor	5000 ohms, 20 watts, fixed, wirewound	"Brown Devil"	Ohmite
R224	Screen	Resistor	Rheostat Model J, 50 watts, 5000 ohms, (use 10,000 ohms, #0332, for remote control)	0330	Ohmite
R225	Screen	Resistor	1500 ohms, 25 watts, variable, wirewound	0376	Ohmite
R226	Not Used		Not Used		
R227	Grid Leak	Resistor	1250 ohms, 50 watts, variable tap, wirewound	0572-B	Ohmite
R228	Meter	Resistor	1 ohm, $\pm 1\%$, wirewound	Type WW4	IRC
R229.1	Trap	Resistor	100 ohms, type "A" GLOBALAR, fixed	3/4" x 4"	Carborundum
R229.2	Trap	Resistor	Same as R229.1		Carborundum
R229.3	Trap	Resistor	Same as R229.1 (used in 316B only)		Carborundum
R230	Remote Antenna Meter Pickup	Resistor	12,000 ohms, 2 watts		Ohmite
R231	Remote Antenna Meter Pickup	Resistor	1000 ohms, 2 watts, $\pm 10\%$, fixed, composition		Ohmite
R232.1	Stabilizing	Resistor	56 ohms, 2 watts, $\pm 10\%$, fixed, composition		Ohmite

CONTINENTAL ELECTRONICS MFG. CO.

SHEET 12
OF 21

www.SteamPoweredRadio.Com

TYPE 315B/316B Transmitter

ELECTRICAL PARTS LIST NO. 7429

UNIT Exciter-Amplifier

REF. DWG. NO. 19002-E

ENGR. JBS

SYMBOL	FUNCTION	NAME OF PART	DESCRIPTION	PART NO.	MANUFACTURER
R232.2	Stabilizing	Resistor	Same as R232.1		Ohmite
R232.3	Stabilizing	Resistor	Same as R232.1		Ohmite
R232.4	Stabilizing	Resistor	Same as R232.1		Ohmite
R232.5	Stabilizing	Resistor	Same as R232.1 (used in 316B only)		Ohmite
R232.6	Saabilizing	Resistor	Same as R232.1 (used in 316B only)		Ohmite
R233	Feedback	Resistor	47,000 ohms, 2 watts, $\pm 10\%$, fixed, composition (used only in some serial numbers)		Ohmite
R234	Feedback	Resistor	10,000 ohms, 2 watts, $\pm 10\%$, fixed, composition (used only in some serial numbers)		Ohmite
R235	Feedback	Resistor	Same as R234		Ohmite
R236	Not Used		Not Used		
R237	Not Used		Not Used		
R238	Meter	Resistor	0.1 ohm, $\pm 1\%$, fixed, wirewound	Type WW4	IRC
R239	Meter	Resistor	Same as R238		IRC
R240	Meter	Resistor	Same as R238		IRC
R241	Meter	Resistor	Same as R231 - REMOVED (2-28-61)		Ohmite
R242	Feedback	Resistor	8200 ohms, 2 watts, $\pm 10\%$, fixed, composition (value different in some models)		Ohmite

CONTINENTAL ELECTRONICS MFG. CO.

SHEET 13
OF 21

www.SteamPoweredRadio.Com

TYPE 315B/316B Transmitter
UNIT Exciter-Amplifier

ELECTRICAL PARTS LIST NO. 7429
REF. DWG. NO. 19002-E ENGR. JBS

SYMBOL	FUNCTION	NAME OF PART	D E S C R I P T I O N	PART NO.	MANUFACTURER
R243	Feedback	Resistor	27,000 ohms, 2 watts, $\pm 10\%$, fixed, composition (10,000 ohms in some models Ser.N .14 and below)		Ohmite
R244	Feedback	Resistor	Same as R234		Ohmite
R245	Feedback Adjust	Resistor	5000 ohms, potentiometer, composition, with locking shaft device	CLU5021	Ohmite
R246	Stabilizing	Resistor	Same as R231		Ohmite
R247	Grid	Resistor	Same as R233		Ohmite
R248	F. B. Load	Resistor	Same as R234		Ohmite
R249	Cathode	Resistor	2200 ohms, 2 watts, $\pm 10\%$, fixed, composition		Ohmite
R250	Meter	Resistor	Same as R219		Ohmite
R251	Screen	Resistor	220,000 ohms, 2 watts, $\pm 10\%$, fixed, composition		Ohmite
R252	Screen	Resistor	680,000 ohms, 2 watts, $\pm 10\%$, fixed, composition		Ohmite
R253	Plate	Resistor	Same as R243		Ohmite
R254	Plate	Resistor	Same as R243		Ohmite
R255	Plate	Resistor	Same as R243		Ohmite
R256	Stabilizing	Resistor	100,000 ohms, 2 watts, $\pm 10\%$, fixed, composition		Ohmite

CONTINENTAL ELECTRONICS MFG. CO.

SHEET 14
OF 21

www.SteamPoweredRadio.Com

TYPE 315B/316B Transmitter

ELECTRICAL PARTS LIST NO. 7429

UNIT Exciter-Amplifier

REF. DWG. NO. 19002-E ENGR. JBS

SYMBOL	FUNCTION	NAME OF PART	DESCRIPTION	PART NO.	MANUFACTURER
R257	Grid	Resistor	Same as R233		Ohmite
R258	Hum	Resistor	25 ohms, 4 watts, potentiometer	M25PK	Mallory
R259	Meter	Resistor	Same as R210		Ohmite
R260	Cathode	Resistor	2500 ohms, 10 watts, fixed, wirewound	"Brown Devil"	Ohmite
R261	Screen	Resistor	35,000 ohms, 20 watts, fixed, wirewound	"Brown Devil"	Ohmite
R262	Screen	Resistor	25,000 ohms, ¹⁰⁰ 20 watts, fixed, wirewound	"Brown Devil"	Ohmite
R263	Plate	Resistor	50,000 ohms, 50 watts, fixed, wirewound	0420	Ohmite
R264	Stabilizing	Resistor	100 ohms, 2 watts, <u>±</u> 10%, fixed, composition		Ohmite
R265	Stabilizing	Resistor	Same as R264		Ohmite
R266	Stabilizing	Resistor	Same as R264		Ohmite
R267	Stabilizing	Resistor	Same as R264		Ohmite
R268	Stabilizing	Resistor	Same as R264		Ohmite
R269	Stabilizing	Resistor	Same as R264		Ohmite
R270	F. B. Divider	Resistor	Same as R256 100,000 Ω 2 WATTS		Ohmite
R271	F. B. Divider	Resistor	Same as R256 ✓		Ohmite
R272	F. B. Divider	Resistor	Same as R256 ✓		Ohmite

CONTINENTAL ELECTRONICS MFG. CO.

SHEET 15
OF 21

www.SteamPoweredRadio.Com

TYPE 315B/316B Transmitter

ELECTRICAL PARTS LIST NO. 7429

UNIT Exciter-Amplifier

REF. DWG. NO. 19002-E ENGR. JBS

SYMBOL	FUNCTION	NAME OF PART	DESCRIPTION	PART NO.	MANUFACTURER
R273	F. B. Divider	Resistor	Same as R249		Ohmite
R274	Feedback	Resistor	Same as R243		Ohmite
R275	Cathode	Resistor	Same as R215		Ohmite
R276	Cathode	Resistor	10,000 ohms, 20 watts, fixed, wirewound	"Brown Devil"	Ohmite
R277	Divider	Resistor	180,000 ohms, 2 watts, $\pm 10\%$, fixed, composition		Ohmite
R278	Divider	Resistor	100,000 ohms, potentiometer, composition, with shaft locking device	CLU-1041	Ohmite
R279.1	Divider	Resistor	Same as R233 <i>47k, 2w</i>		Ohmite
R279.2	Divider	Resistor	Same as R233		Ohmite
R280	Isolating	Resistor	330,000 ohms, 2 watts, $\pm 10\%$, fixed, composition		Ohmite
R281	Plate	Resistor	200,000 ohms, 2 ohms, $\pm 5\%$ fixed, composition		Ohmite

CONTINENTAL ELECTRONICS MFG. CO.

www.SteamPoweredRadio.Com

SHEET 16
OF 21

TYPE 315B/316-B Transmitter

ELECTRICAL PARTS LIST NO. 7429

UNIT Exciter-Amplifier Unit

REF. DWG. NO. 19002-E ENGR. JBS

SYMBOL	FUNCTION	NAME OF PART	DESCRIPTION	PART NO.	MANUFACTURER
R282	Plate	Resistor	Same as R281		Ohmite
R283	Plate	Resistor	Same as R281		Ohmite
R284	Plate	Resistor	Same as R281		Ohmite
R285	Plate	Resistor	50,000 ohms, 20 watts, wirewound		Ohmite
R286	Plate	Resistor	Same as R285		Ohmite
R287	Dropping	Resistor	5000 ohms, 10 watts	"Brown Devil"	Ohmite
R288	Dropping	Resistor	30,000 ohms, 20 watts, fixed, wirewound	"Brown Devil"	Ohmite
R289	Dropping	Resistor	Same as R288		Ohmite
R290	Dropping	Resistor	25,000 ohms, 160 watts, 8-1/2" L., D core	Type 160F	Ward Leonard
R291	Dropping	Resistor	Same as R290		Ward Leonard
R292	Dropping	Resistor	Same as R290		Ward Leonard
R293	Dropping	Resistor	50,000 ohms, 160 watts, 8-1/2" L., D core	Type 160F	Ward Leonard
R294	Dropping	Resistor	Same as R293		Ward Leonard
R295	Surge	Resistor	1600 ohms, type "B", GLOBAR, fixed	1" x 12"	Carborundum
R296	Meter	Resistor	5 megohms, precision	TM 7982	IRC
R297	Audio Attenuator	Resistor	600/600 ohms, 3 DB (power cutback only)	T-154	Daven

CONTINENTAL ELECTRONICS MFG. CO.

SHEET 17
OF 21

www.SteamPoweredRadio.Com

TYPE 315B/316B Transmitter ELECTRICAL PARTS LIST NO. 7429 ENGR. _____
 UNIT Exciter-Amplifier Unit REF. DWG. NO. _____

SYMBOL	FUNCTION	NAME OF PART	DESCRIPTION	PART NO.	MANUFACTURER
R298	Meter	Resistor	Same as R296		IRC
R299	Pad	Resistor	600/600 ohms, 6 db atten.	Type 154-H	Daven
RT201	Delay	Thermistor		Type D503	General Electric
RT202	Delay	Thermistor	Same as RT201		General Electric
S201	Meter	Switch	2 pole, 2-11 positions	2513	Centralab
S202	Oscillator	Switch	3 pole, 1 section, 2-3 positions	174-C	Mallory
S203	Door	Switch	Split "Vee" interlock	7460330-G4	General Electric
S204	Air	Switch	Per CEMC Dwg. No.	5355-D BZ-2RW80	CEMC Micro
S205	Grounding	Switch	Per CEMC Dwg. No.	19089-D	CEMC

CONTINENTAL ELECTRONICS MFG. CO.

SHEET 18
OF 21

www.SteamPoweredRadio.Com

TYPE 315B/316B Transmitter

ELECTRICAL PARTS LIST NO. 7429

UNIT Exciter-Amplifier Unit

REF. DWG. NO. 19002-E ENGR. JBS

SYMBOL	FUNCTION	NAME OF PART	D E S C R I P T I O N	PART NO.	MANUFACTURER
T201	Filament	Transformer	Primary 208/230 volts; secondary 7.7 volts at 75 amps., per CEMC Spec. No. 10686	CEMC Spec. No. 10686	Electro Engr.
T202	Filament	Transformer	Same as T201		Electro Engr.
T203	Filament	Transformer	Same as T201 (used in 316B only)		Electro Engr.
T204	Filament	Transformer	Primary 115/230 volts; secondary 6.3 volts at 5 amps.	F65	Chicago Trans.
T205	Filament	Transformer	Same as T204		Chicago Trans.
T206	Filament	Transformer	Primary 115/230 volts, secondary 6.3 volts at 10 amps.	F610	Chicago Trans.
T207	Input	Transformer	Primary 150/600 ohms; secondary 60,000 ohms	B1-2	Chicago Trans.
TB201	Interconnecting	Terminal Board	12 terminal block (2 required)	6012	Burke
TB202	Interconnecting	Terminal Board	Size 141 barrier strip, 8 terminals, with backing board	8-141	Cinch Jones
TB203	Interconnecting	Terminal Board	Size 141 barrier strip, 15 terminals, with backing strip	15-141	Cinch Jones

CONTINENTAL ELECTRONICS MFG. CO.

www.SteamPoweredRadio.Com

SHEET 19
OF 21

TYPE 315B/316-B Transmitter

ELECTRICAL PARTS LIST NO. 7429

UNIT Exciter-Amplifier Unit

REF. DWG. NO. 19002-E ENGR. JBS

SYMBOL	FUNCTION	NAME OF PART	DESCRIPTION	PART NO.	MANUFACTURER
TB204	Interconnecting	Terminal Board	Size 141 barrier strip, 12 terminals, with backing strip	12-141	Cinch Jones
TB205	Interconnecting	Terminal Board	Size 141 barrier strip, 3 terminals, with backing strip	3-141	Cinch Jones
V201	Oscillator	Tube	In 30XT Oscillator	6AG7	General Electric
V202	Volt. Reg.	Tube	In 30XT Oscillator	0B2	General Electric
V203	Buffer	Tube		Type 807	General Electric
V204	Driver	Tube		Type 4-65A	Eimac
V205.1	Power Amplifier	Tube	Tetrode power amplifier	Type 4CX5000A	Eimac
V205.2	Power Amplifier	Tube	Same as V205.1		Eimac
V205.3	Power Amplifier	Tube	Same as V205.1 (used in 316B only)		Eimac
V206	1st Audio	Tube	Same as V203		General Electric
V207	2nd Audio	Tube	Same as V204		Eimac
V208.1	Modulator	Tube	Same as V204		Eimac
V208.2	Modulator	Tube	Same as V204		Eimac

CONTINENTAL ELECTRONICS MFG. CO.

www.SteamPoweredRadio.Com

SHEET 20
OF 21

TYPE 315B/316B Transmitter

ELECTRICAL PARTS LIST NO. 7429

UNIT Exciter-Amplifier

REF. DWG. NO. 19002-E ENGR. JBS

SYMBOL	FUNCTION	NAME OF PART	DESCRIPTION	PART NO.	MANUFACTURER
V208.3	Modulator	Tube	Same as V204		Eimac
V209	F. B. Rectifier	Tube	Full-wave rectifier	Type 6X5	General Electric
V210	D. C. Amplifier	Tube	Same as V203		General Electric
V211	Regulator	Tube	Voltage regulator	OB2	General Electric
XDS201	Regular	Lamp Assembly	Holder with built-in resistor and white lens (used only for Conelrad switching)	147-408-6	E. F. Johnson
XDS202	Conelrad	Lamp Assembly	Same as XDS201 (Used only for Conelrad switching)		E. F. Johnson
XVS201 and XVS202		Socket	In 30XT oscillator		
XVS203	Tube	Socket	5 pin socket	122-225-1	E. F. Johnson
XVS204	Tube	Socket	7 pin socket	122-247-1	E. F. Johnson
XVS205.1	Tube	Socket	Air system socket with chimney	SK-300 SK-306	Eimac

CONTINENTAL ELECTRONICS MFG. CO.

SHEET 21
OF 21

www.SteamPoweredRadio.Com

TYPE 315B/316B Transmitter

ELECTRICAL PARTS LIST NO. 7429

UNIT Exciter-Amplifier

REF. DWG. NO. 19002-E

ENGR.

JBS

SYMBOL	FUNCTION	NAME OF PART	DESCRIPTION	PART NO.	MANUFACTURER
XVS205.2	Tube	Socket	Same as XVS205.1		Eimac
XVS205.3	Tube	Socket	Same as XVS205.1 (used in 316B only)		Eimac
XVS206	Tube	Socket	Same as XVS203		E. F. Johnson
XVS207	Tube	Socket	Same as XVS204		E. F. Johnson
XVS208.1	Tube	Socket	Same as XVS204		E. F. Johnson
XVS208.2	Tube	Socket	Same as XVS204		E. F. Johnson
XVS208.3	Tube	Socket	Same as XVS204		E. F. Johnson
XVS209	Tube	Socket	8 pin octal	335-PH TS101P01	Elco
XVS210	Tube	Socket	Same as XVS203		E. F. Johnson
XVS211	Tube	Socket	7 pin miniature	238-PH TS102C01	Elco
XCS201	Capacitor	Socket	Capacitor socket for 1" dia. type "FP" can	2C5	Jones

CONTINENTAL ELECTRONICS MFG. CO.

www.SteamPoweredRadio.Com

SHEET 1
OF 3

TYPE 30XT Crystal Oscillator

ELECTRICAL PARTS LIST NO. 1

UNIT

REF. DWG. NO. 4841-B

ENGR.

MWB

SYMBOL	FUNCTION	NAME OF PART	DESCRIPTION	PART NO.	MANUFACTURER
C1	Freq. Adjust.	Capacitor	2.6 to 19.7 mmfd.	20M11	E. F. Johnson
C2	Feedback	Capacitor	51 mmfd., $\pm 2\%$, 1200 V DC test, 600 DCWV	TCZ51	Centralab
C3	Feedback	Capacitor	1000 mmfd., $\pm 20\%$, 1000 V DC test, 600 DCWV	D6-102	Centralab
C4	V1S Screen Bypass	Capacitor	0.01 mfd., $\pm 20\%$, 1000 V DC test, 600 DCWV	DD-1032	Centralab
C5	Plate Supply Bypass	Capacitor	Same as C4		Centralab
C6	Output Coupling	Capacitor	Same as C4		Centralab
J1	Connector	Plug		P-408-AB	Cinch Jones

AUG 24 1959

CONTINENTAL ELECTRONICS MFG. CO.

www.SteamPoweredRadio.Com

SHEET 2
OF 3

TYPE 30XT Crystal Oscillator

ELECTRICAL PARTS LIST NO. 1

UNIT _____

REF. DWG. NO. 4841-B

ENGR. MWB

SYMBOL	FUNCTION	NAME OF PART	DESCRIPTION	PART NO.	MANUFACTURER
L1	V1 Cathode Choke	RF Choke	750 microhenry	R33	National
L2	V1 Plate Peaking	Peaking Coil	Video series, 120 microhenry	71529	RCA
R1	V1 Grid Leak	Resistor	47,000 ohms, $\pm 10\%$, 1 watt, composition		Ohmite
R2	V1 Cathode	Resistor	47 ohms, $\pm 10\%$, 1 watt, composition		Ohmite
R3	V1 Cathode Metering	Resistor	2 ohms, special precision wirewound, 1 watt, $\pm 1\%$	PT-4	Inresco
R4	V1 Screen Dropping	Resistor	10,000 ohms, $\pm 10\%$, 10 watts, 1-3/4" x 5/16", wirewound		Ohmite
R5	Suppressor	Resistor	10 ohms, $\pm 10\%$, 1 watt, composition		Ohmite

AUG 24 1959

CONTINENTAL ELECTRONICS MFG. CO.

www.SteamPoweredRadio.Com

SHEET 3
OF 3

TYPE 30XT Crystal Oscillator

ELECTRICAL PARTS LIST NO. 1

UNIT _____

REF. DWG. NO. 4841-B ENGR. MWB

SYMBOL	FUNCTION	NAME OF PART	DESCRIPTION	PART NO.	MANUFACTURER
V1	Oscillator	Tube		6AG7	General Electric
V2	V1 Screen Voltage Regulator	Tube		0B2	General Electric
VS1	Tube	Socket Turret	2" high, 12 terminals in 2 rings	8-0-12T	Vector
VS2	Tube	Socket	7 pin, RTMA saddle type, bottom mounting, mica filled	105	Elco
YS1	Crystal	Socket	Steatite octal socket, with mounting plate	49RSS8	Amphenol

MFG 2 4 1958

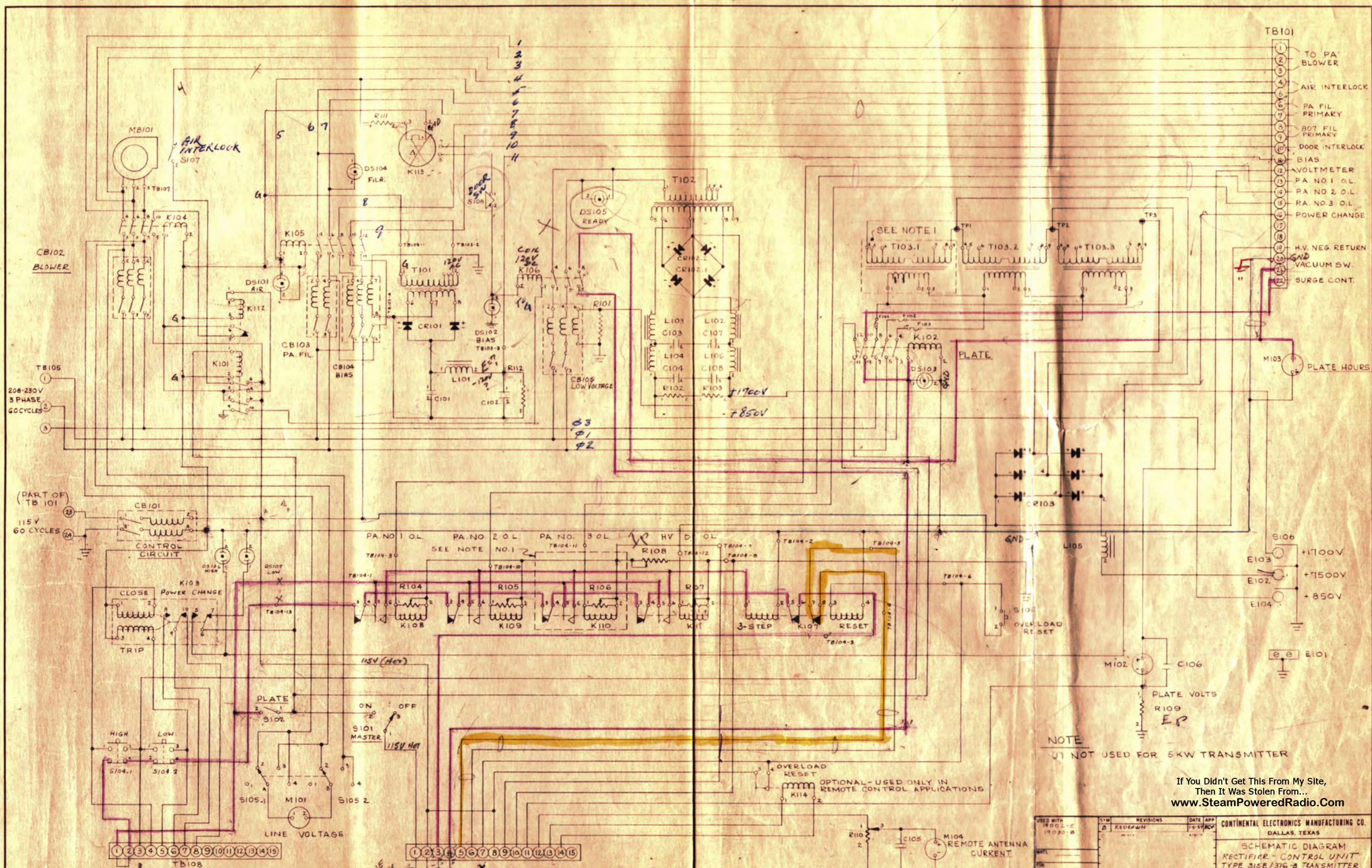

NOTE
 (1) NOT USED FOR 5KW TRANSMITTER

If You Didn't Get This From My Site,
 Then It Was Stolen From...
www.SteamPoweredRadio.Com

THESE DRAWINGS AND SPECIFICATIONS ARE THE PROPERTY OF CONTINENTAL ELECTRONICS MANUFACTURING COMPANY, INC., OF DALLAS, TEXAS AND SHALL NOT BE REPRODUCED OR COPIED OR USED AS THE BASIS FOR THE MANUFACTURE OR SALE OF APPARATUS WITHOUT PERMISSION.

USED WITH 19001-E 19030-B	SYMBOL REDEFINITION	REVISIONS DATE APP 15-5-57	DATE APP 15-5-57	CONTINENTAL ELECTRONICS MANUFACTURING CO. DALLAS, TEXAS
MATERIAL				SCHEMATIC DIAGRAM RECTIFIER-CONTROL UNIT TYPE 315B/316-B TRANSMITTER SERIAL NOS 715 & ABOVE
FINISH				
UNLESS OTHERWISE SPECIFIED DIMENSIONS IN INCHES TOLERANCES FRACT. DEC. ANG. 8764 8.015 3/78				SCALE
APP'D	ENG	DRWN	MDF	19001-E

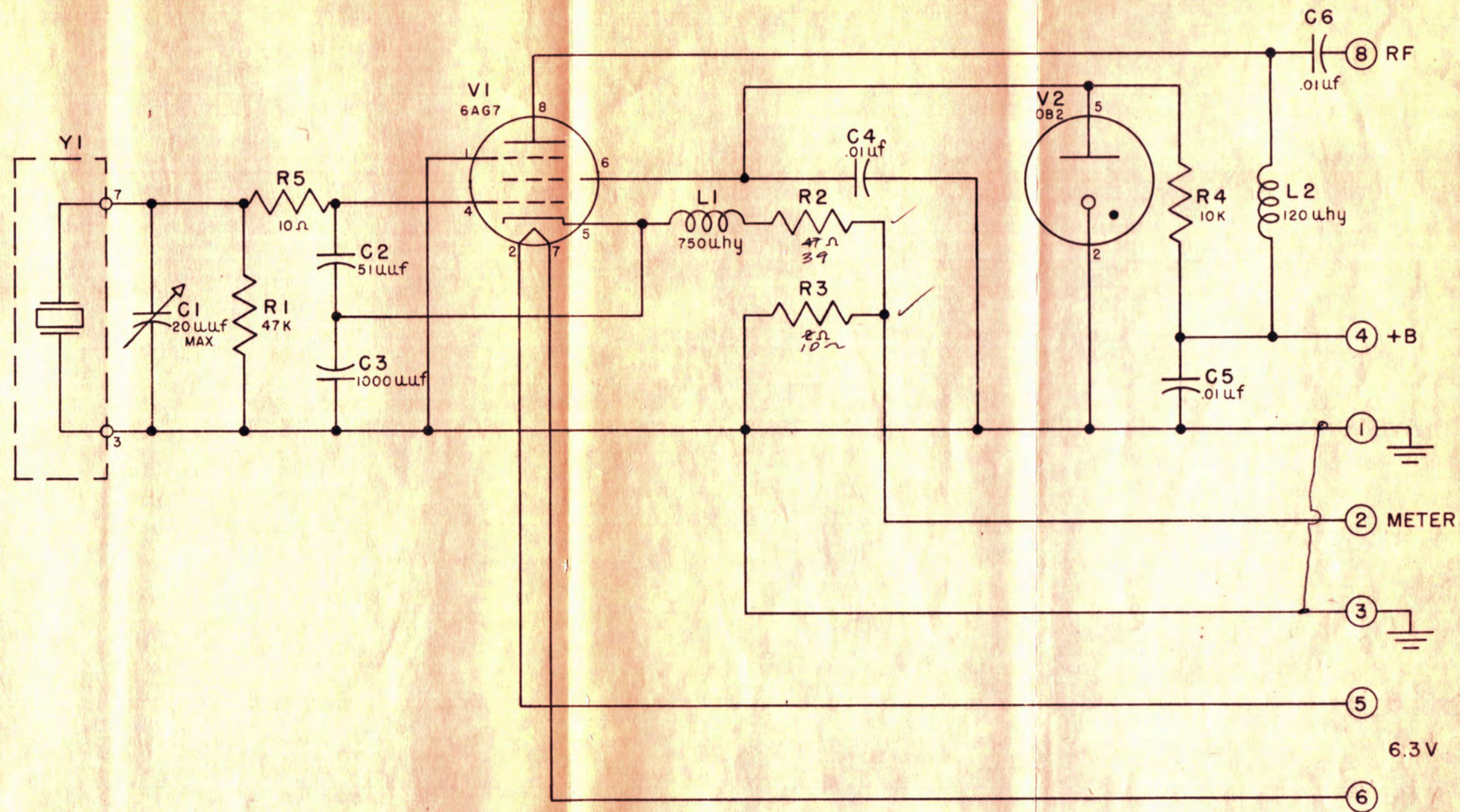

THESE DRAWINGS AND SPECIFICATIONS ARE THE PROPERTY OF CONTINENTAL ELECTRONICS MANUFACTURING COMPANY, INC., OF DALLAS, TEXAS AND SHALL NOT BE REPRODUCED, OR COPIED OR USED AS THE BASIS FOR THE MANUFACTURE OR SALE OF APPARATUS WITHOUT PERMISSION.

USED WITH:

ISSUE:

1 9-18-52
AB

CONTINENTAL ELECTRONICS MANUFACTURING CO.
DALLAS, TEXAS

TYPE 30 XT
CRYSTAL OSCILLATOR
550-1600 KC

SCALE:

APP'D	ENG.	DRAWN
		MB

4841-B

If You Didn't Get This From My Site,
Then It Was Stolen From...
www.SteamPoweredRadio.Com

H.V. TRANSFER CONTACTOR

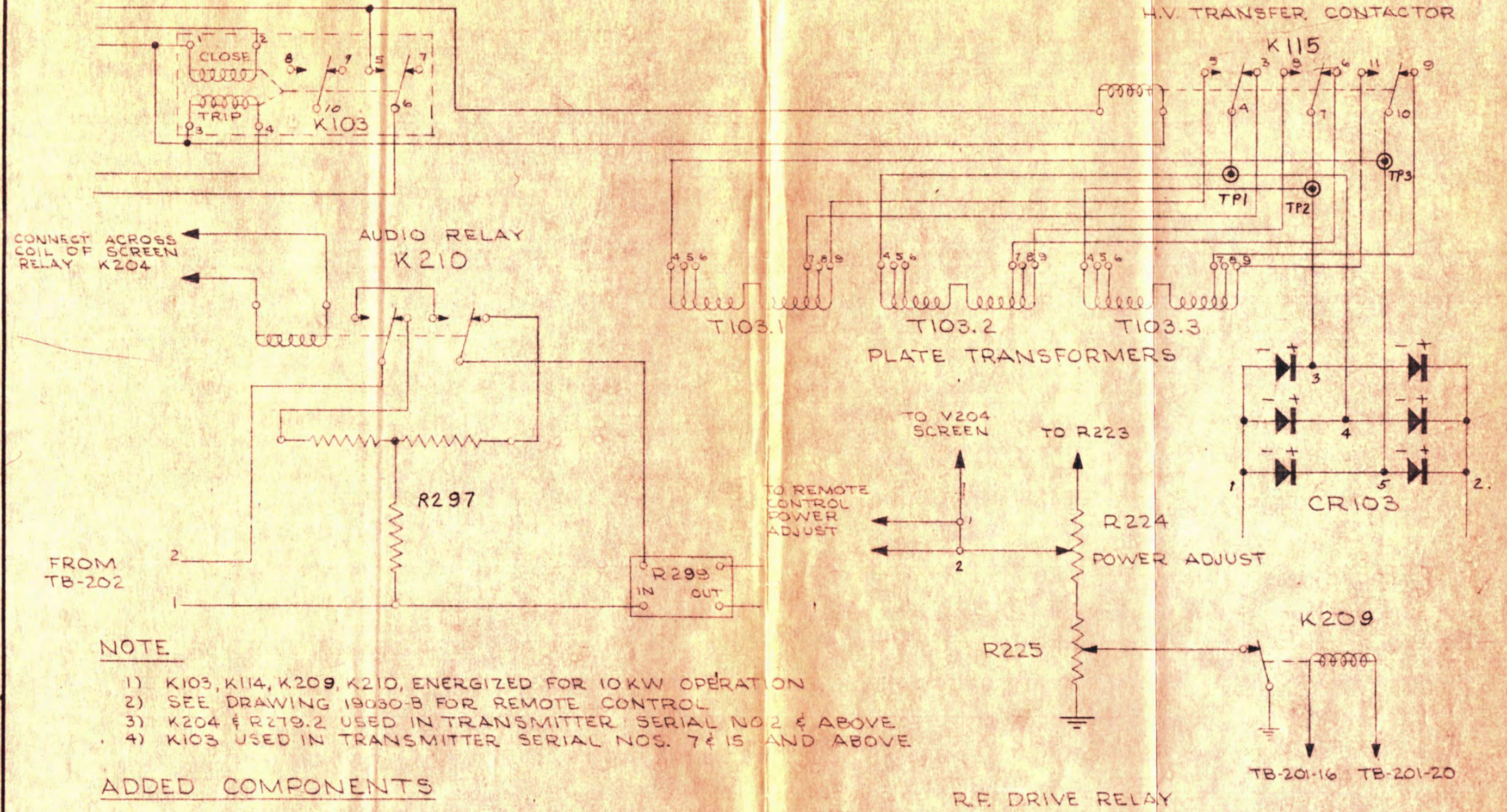

NOTE

- 1) K103, K114, K209, K210, ENERGIZED FOR 10KW OPERATION
- 2) SEE DRAWING 19030-B FOR REMOTE CONTROL
- 3) K204 & R279.2 USED IN TRANSMITTER SERIAL NO 2 & ABOVE
- 4) K103 USED IN TRANSMITTER SERIAL NOS. 7 & 15 AND ABOVE

ADDED COMPONENTS

- K115 3PDT H.V. CONTACTOR-10KV INSULATION, 115V A.C. COIL (CEMC)
- K209 SP. NORMALLY CLOSED RELAY - 115V A.C. COIL. STRUTHERS-DUNN BIXXA
- K210 DPDT RELAY-115V AC. COIL. AUTOMATIC ELECTRIC R-83
- R297 600/600 OHM TEE ATTENUATOR-3DB LOSS
- R225 1500 OHM, 25W, ADJUSTABLE RESISTOR- OHMITE NO. 0376

THESE DRAWINGS AND SPECIFICATIONS ARE THE PROPERTY OF CONTINENTAL ELECTRONICS MANUFACTURING COMPANY, INC., OF DALLAS, TEXAS AND SHALL NOT BE REPRODUCED, OR COPIED OR USED AS THE BASIS FOR THE MANUFACTURE OR SALE OF APPARATUS WITHOUT PERMISSION.

USED WITH	SYM	REVISIONS	DATE	APP
1900 -E	A	REDRAWN	9/2/54	DFA
	B	RE-NUMBERED AUDIO PAD	7/4/58	R-PB
	C	RE-NUMBERED K209	12/3/58	R-PB
MATL				
FIN				
UNLESS OTHERWISE SPECIFIED				
DIMENSIONS IN INCHES				
TOLERANCES				
FRACT.	DEC.	ANG.		
±1/64	±.015	±1/2°		

CONTINENTAL ELECTRONICS MANUFACTURING CO.
DALLAS, TEXAS

MODIFICATION DIAGRAM
10 TO 5KW POWER CUTBACK
TYPE 316B TRANSMITTER

SCALE:			
APP'D.	ENG.	DRAWN	19345-B
		DFA	
		9/2/58	

If You Didn't Get This From My Site,
Then It Was Stolen From...
www.SteamPoweredRadio.Com

NOTE:

2. FOR REMOTE CONTROL OPERATION,
REMOVE JUMPERS BETWEEN TB-102
1&2, AND 3&4, IN RECTIFIER AND
CONTROL UNIT

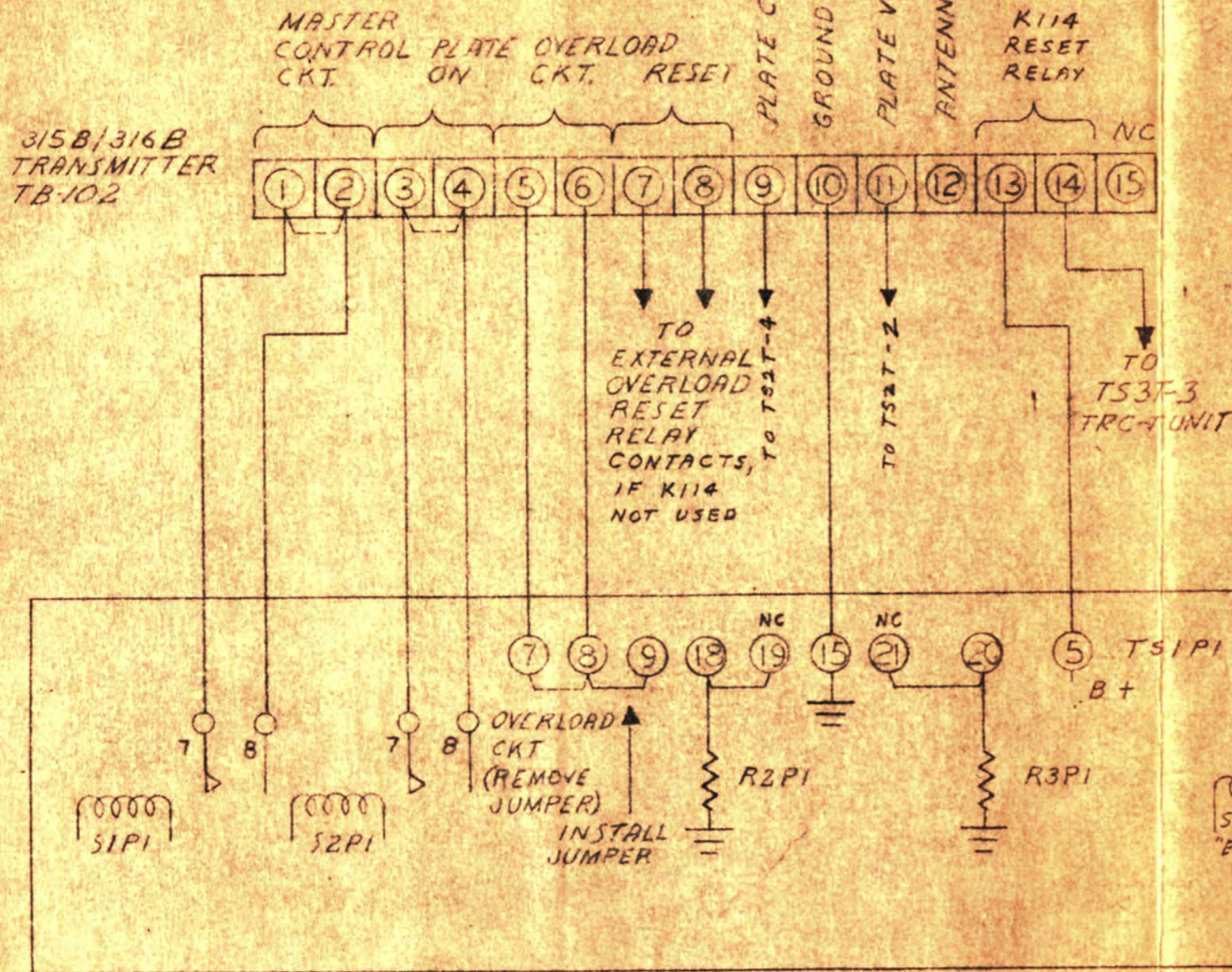

TRC-PI TRANSMITTER POWER PANEL

NOTE:

1. STRAP BETWEEN
1&2 REMOVED
FOR REMOTE POWER
ADJUST.

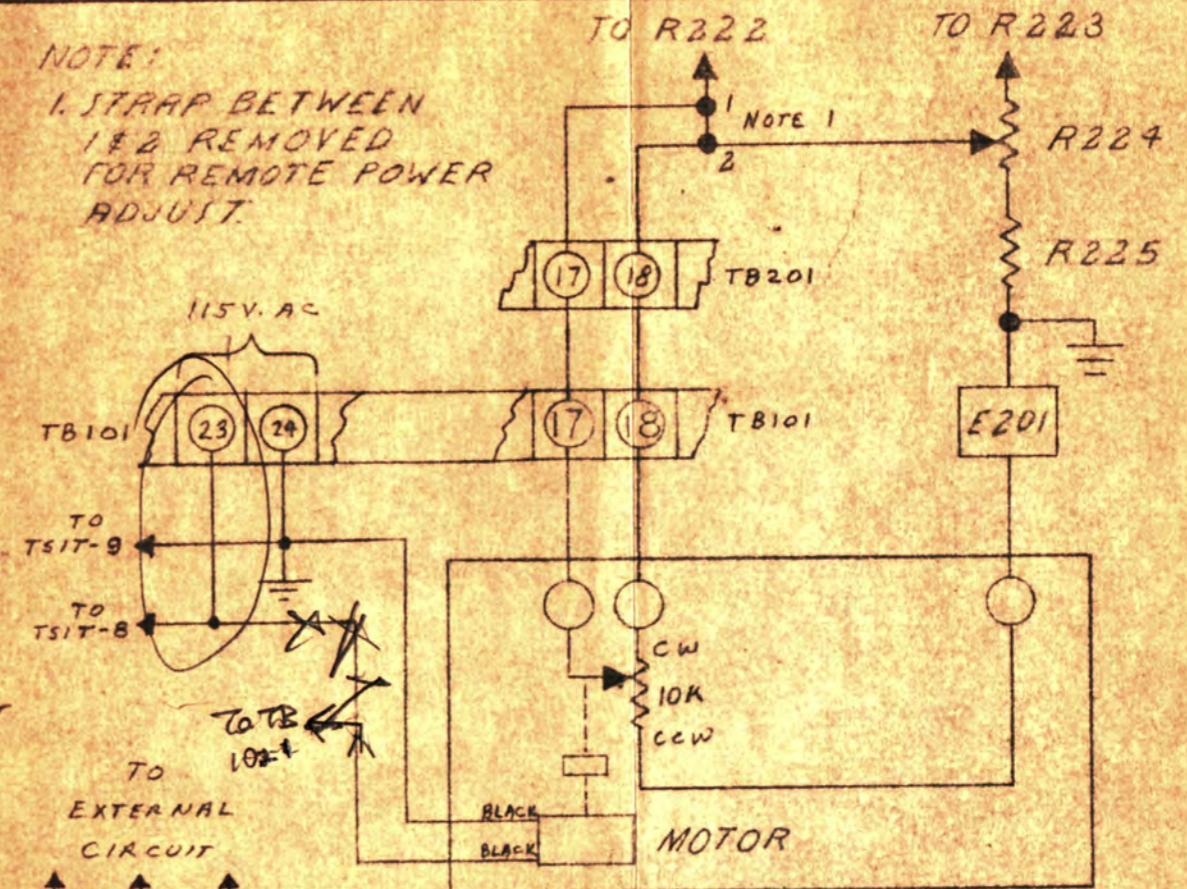

MC11
MOTOR CONTROL UNIT
POWER ADJUST.

NOTE:

3. R224 IS 10,000 OHMS WHEN
USED WITH REMOTE CONTROL.

SEE REVISED DWG.
NEXT PAGE

THESE DRAWINGS AND SPECIFICATIONS ARE THE PROPERTY OF CONTINENTAL ELECTRONICS MANUFACTURING COMPANY, INC., OF DALLAS, TEXAS AND SHALL NOT BE REPRODUCED, OR COPIED OR USED AS THE BASIS FOR THE MANUFACTURE OR SALE OF APPARATUS WITHOUT PERMISSION.

USED WITH	SYM	REVISIONS	DATE	APP
5799-E	A	REDRAWN	5-12-58	
5800-E	B	ADDED POWER CHG	5-11-58	
5844-B	C	DELETED POWER CHG.	9-5-58	APB
19001-E	D	CHG. DET. CONT. ADDED TB101-17-18	10-7-58	APB
MATL	E	ADDED NOTE 3, CHG. POT TO 10K	12-31-58	APB
FIN	F	CHG'ED. S1P1-S2P1 CONT. NOS.	8-3-59	APB

UNLESS OTHERWISE SPECIFIED
DIMENSIONS IN INCHES
TOLERANCES
FRACT. DEC. ANG.
±1/64 ±.015 ±1/2

If You Didn't Get This From My Site,
Then It Was Stolen From...
www.SteamPoweredRadio.Com

CONTINENTAL ELECTRONICS MANUFACTURING CO.
DALLAS, TEXAS

INTERCONNECTION DIA.
REMOTE CONTROL OPERATION
OF 315B/316B TRANSMITTER

SCALE:

APP'D. ENG. DRAWN
PFB HORTON
5-12-58

19030-B

NOTE:

2. FOR REMOTE CONTROL OPERATION,
REMOVE JUMPERS BETWEEN TB-102
1 & 2, AND 3 & 4, IN RECTIFIER AND
CONTROL UNIT

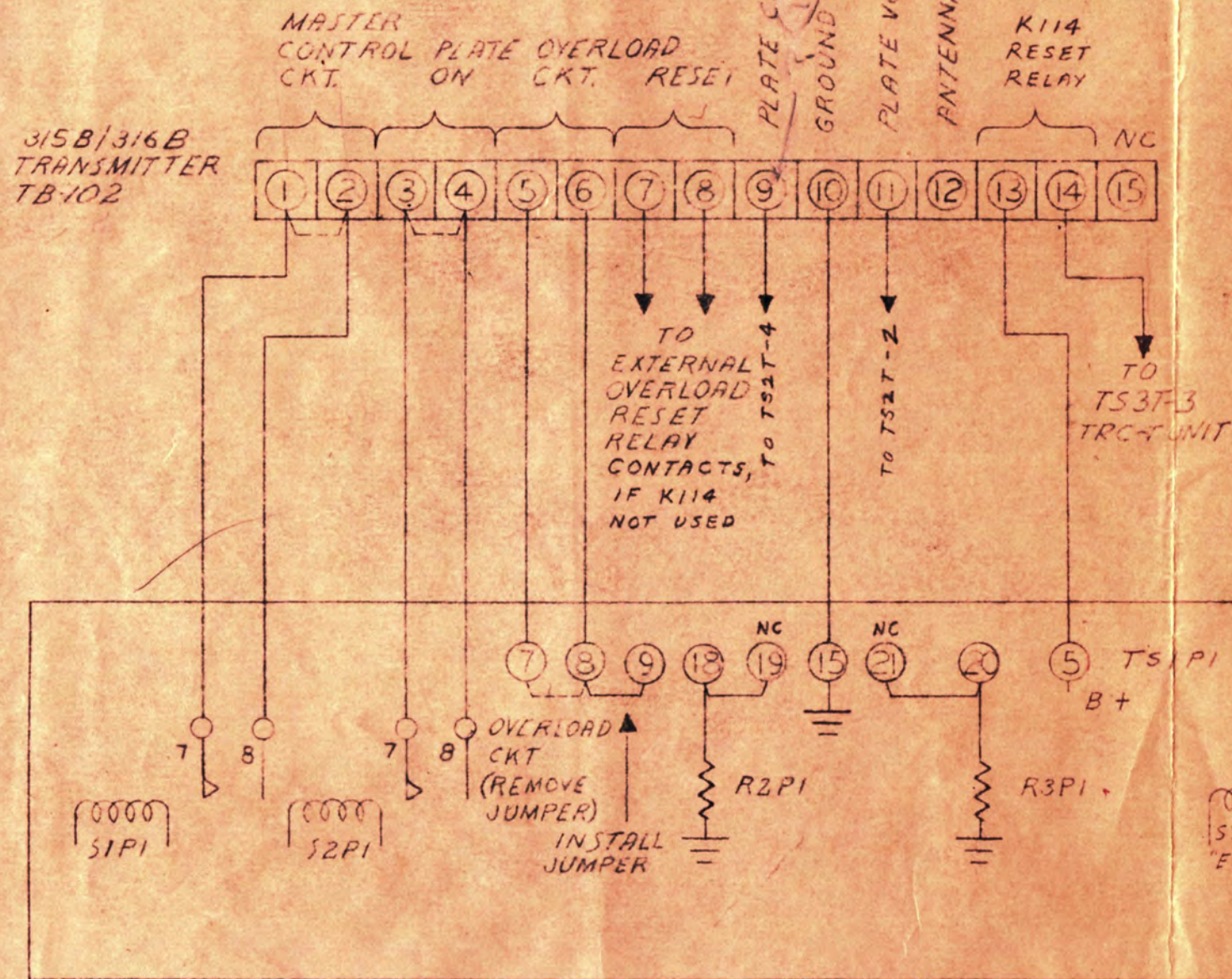

TRC-PI TRANSMITTER POWER PANEL

NOTE:

1. STRAP BETWEEN
1 & 2 REMOVED
FOR REMOTE POWER
ADJUST.

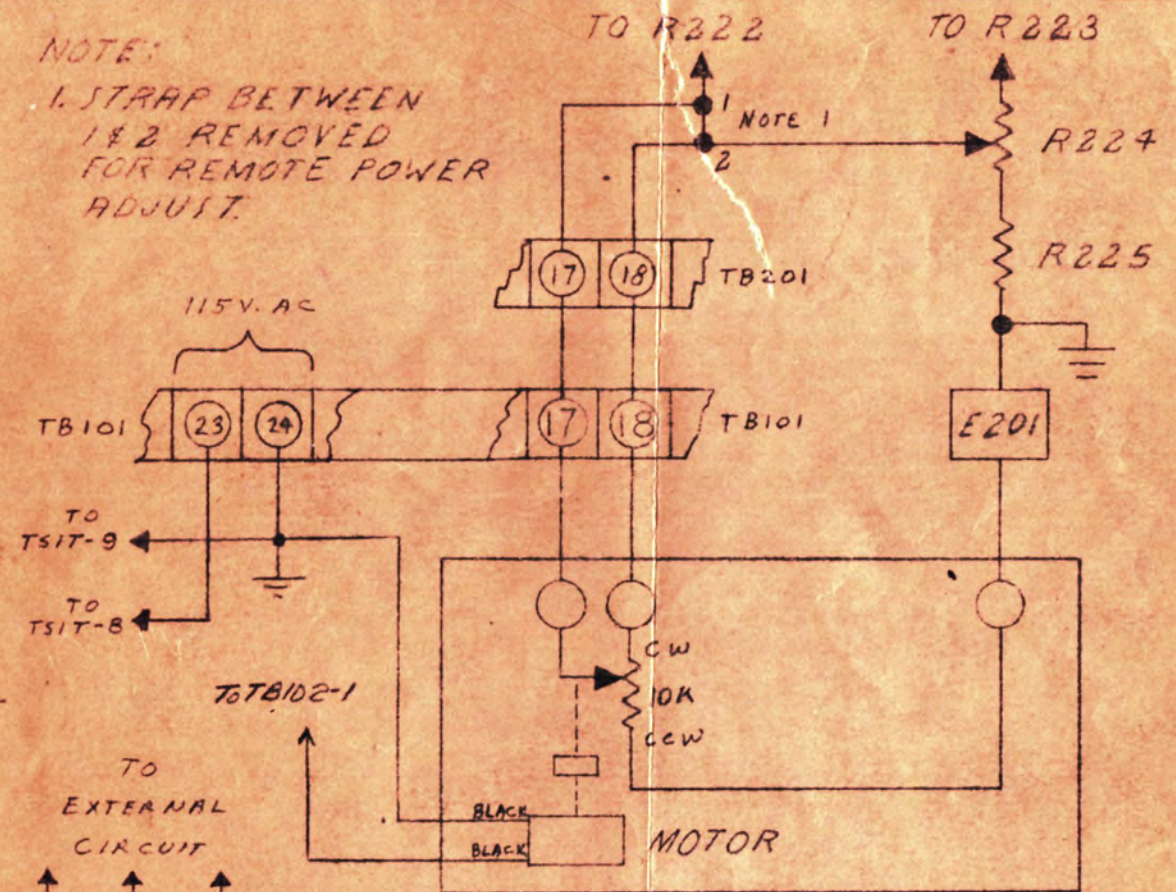

MC1T1
MOTOR CONTROL UNIT
POWER ADJUST.

NOTE:

3. R224 IS 10,000 OHMS WHEN
USED WITH REMOTE CONTROL.

THESE DRAWINGS AND SPECIFICATIONS ARE THE PROPERTY OF CONTINENTAL ELECTRONICS MANUFACTURING COMPANY, INC., OF DALLAS, TEXAS AND SHALL NOT BE REPRODUCED, OR COPIED OR USED AS THE BASIS FOR THE MANUFACTURE OR SALE OF APPARATUS WITHOUT PERMISSION.

USED WITH 5799-E 5800-E 5844-B 19001-E	SYM	REVISIONS	DATE	APP
MATL	A	REDRAWN	5-12-58	
FIN	B	ADDED POWER CHG.	5-21-58	
	C	DELETED POWER CHG.	7-5-58	AFB
	D	CHG. DET. CARM. ADDED TB101-17-18	10-7-58	210
	E	ADDED NOTE 3, CHG. MC1T1 TO 10K	12-31-58	113
	F	CHG'ED. S1P1-S2P1 CONT. NFB.	3-3-59	AFB
	G	MOTOR FIELD CORRECT	4-13-59	CT
UNLESS OTHERWISE SPECIFIED DIMENSIONS IN INCHES TOLERANCES FRACT. DEC. ANG. ±1/64 ±.015 ±1/2°				

If You Didn't Get This From My Site,
Then It Was Stolen From...
www.SteamPoweredRadio.Com

CONTINENTAL ELECTRONICS MANUFACTURING CO.
DALLAS, TEXAS

INTERCONNECTION DIA.
REMOTE CONTROL OPERATION
OF 315B/316B TRANSMITTER

SCALE: —		
APP'D.	ENG.	DRAWN
	AFB	WUT/11001
		5-12-58

19030-B

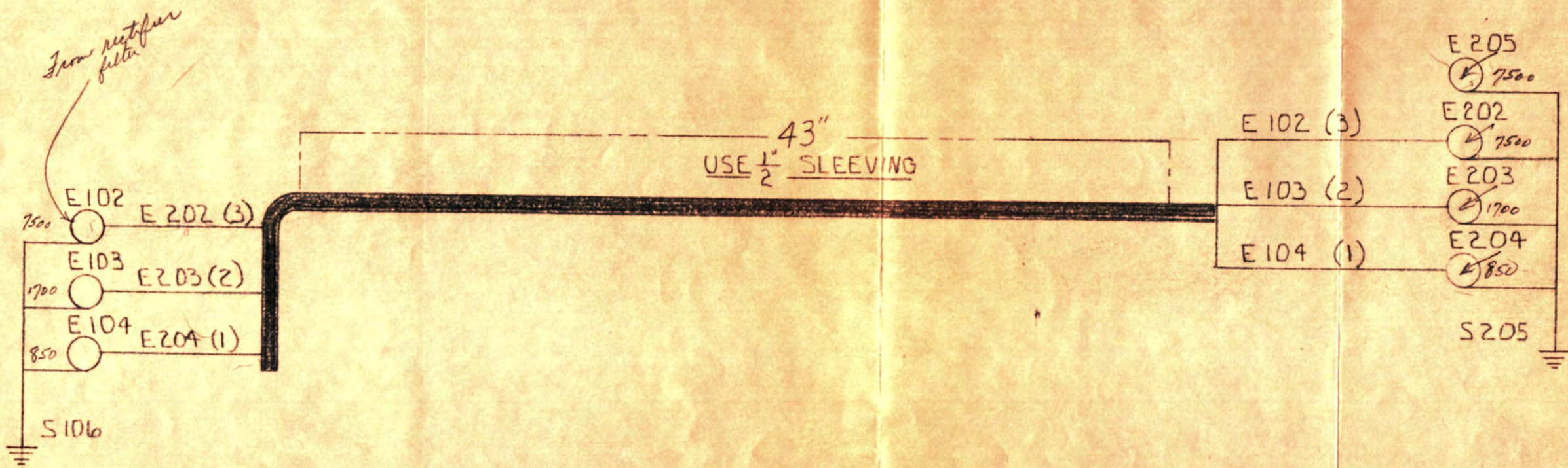

THESE DRAWINGS AND SPECIFICATIONS ARE THE PROPERTY OF CONTINENTAL ELECTRONICS MANUFACTURING COMPANY, INC., OF DALLAS, TEXAS AND SHALL NOT BE REPRODUCED, OR COPIED OR USED AS THE BASIS FOR THE MANUFACTURE OR SALE OF APPARATUS WITHOUT PERMISSION.

USED WITH 19001-E 19002-E	SYM	REVISIONS	DATE	APP
MATL				
FIN				
UNLESS OTHERWISE SPECIFIED				
DIMENSIONS IN INCHES				
TOLERANCES				
FRACT.	DEC.	ANG.		
±1/64	±.015	±1/2°		

If You Didn't Get This From My Site,
Then It Was Stolen From...
www.SteamPoweredRadio.Com

CONTINENTAL ELECTRONICS MANUFACTURING CO. DALLAS, TEXAS		
H.V. INTERCONNECTING CABLE		
RECT. UNIT TO PA. UNIT		
TYPE 315B/316B/317B TRANSMITTER		
SCALE: NONE		
APP'D.	ENG.	DRAWN
		RICH
		1-21-59
19855-B		

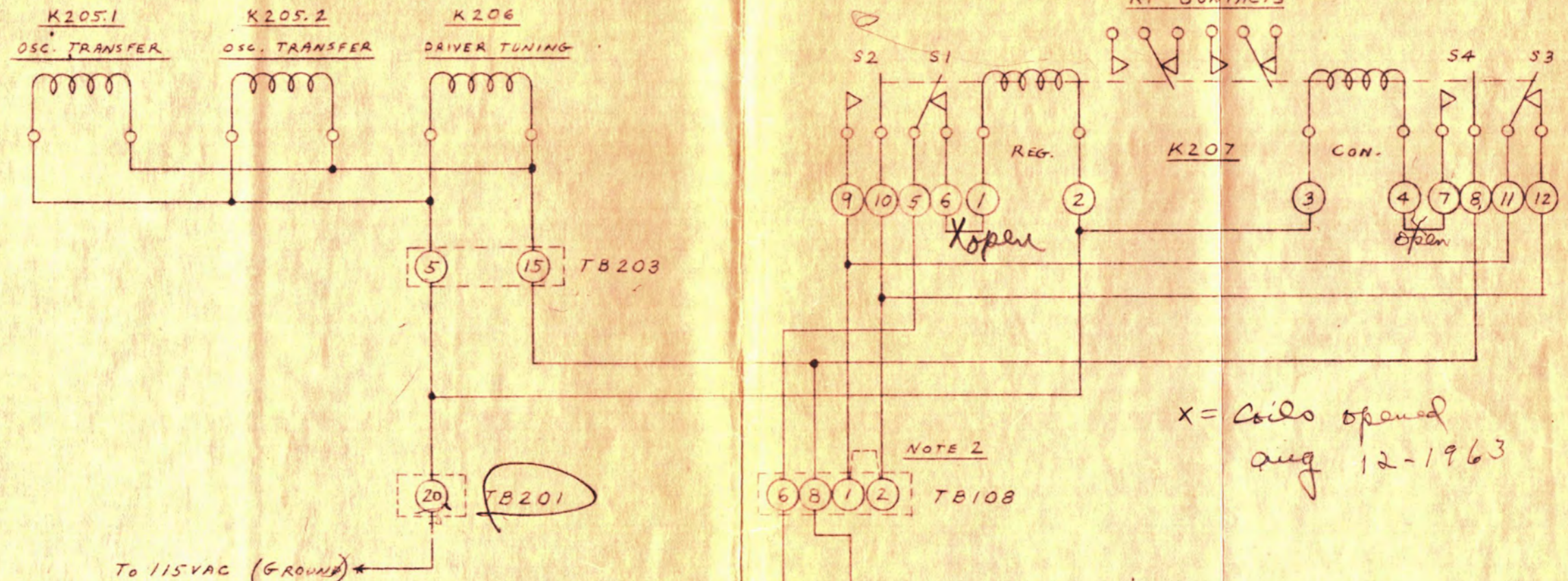

X = Coils opened
aug 12-1963

3 OR 4
DISCONNECTED
1/12/63

- NOTE:
1. ALL RELAYS SHOWN IN "CONELRAD" POSITION.
 2. STRAP REMOVED, TB108 -1 TO -2
 3. CONNECTION REMOVED, TB108-7 TO K103-9.
NEW CONNECTION, K103-6 TO K103-9.
 4. IN SOME CASES, K104 CONTACTS USED TO
ADJUST FEEDBACK LOOP GAIN ON CONELRAD.
IN NON-CUTBACK TRANSMITTERS, K104 CONTACTS
ACROSS R279.2, ARE NOT USED. (SEE 19002-E.)

THESE DRAWINGS AND SPECIFICATIONS ARE THE PROPERTY OF CONTINENTAL ELECTRONICS MANUFACTURING COMPANY, INC., OF DALLAS, TEXAS AND SHALL NOT BE REPRODUCED, OR COPIED OR USED AS THE BASIS FOR THE MANUFACTURE OR SALE OF APPARATUS WITHOUT PERMISSION.

USED WITH	SYM	REVISIONS	DATE	APP	CONTINENTAL ELECTRONICS MANUFACTURING CO. DALLAS, TEXAS
19001-E 19002-E 19043-A					
MATL					SCALE:
FIN					APP D
UNLESS OTHERWISE SPECIFIED DIMENSIONS IN INCHES TOLERANCES FRACT. DEC. ANG. ±1/64 ±0.5 ±1/2°					ENG.
					DRAWN APP 145817 SY
					19947-B

If You Didn't Get This From My Site,
Then It Was Stolen From...
www.SteamPoweredRadio.Com

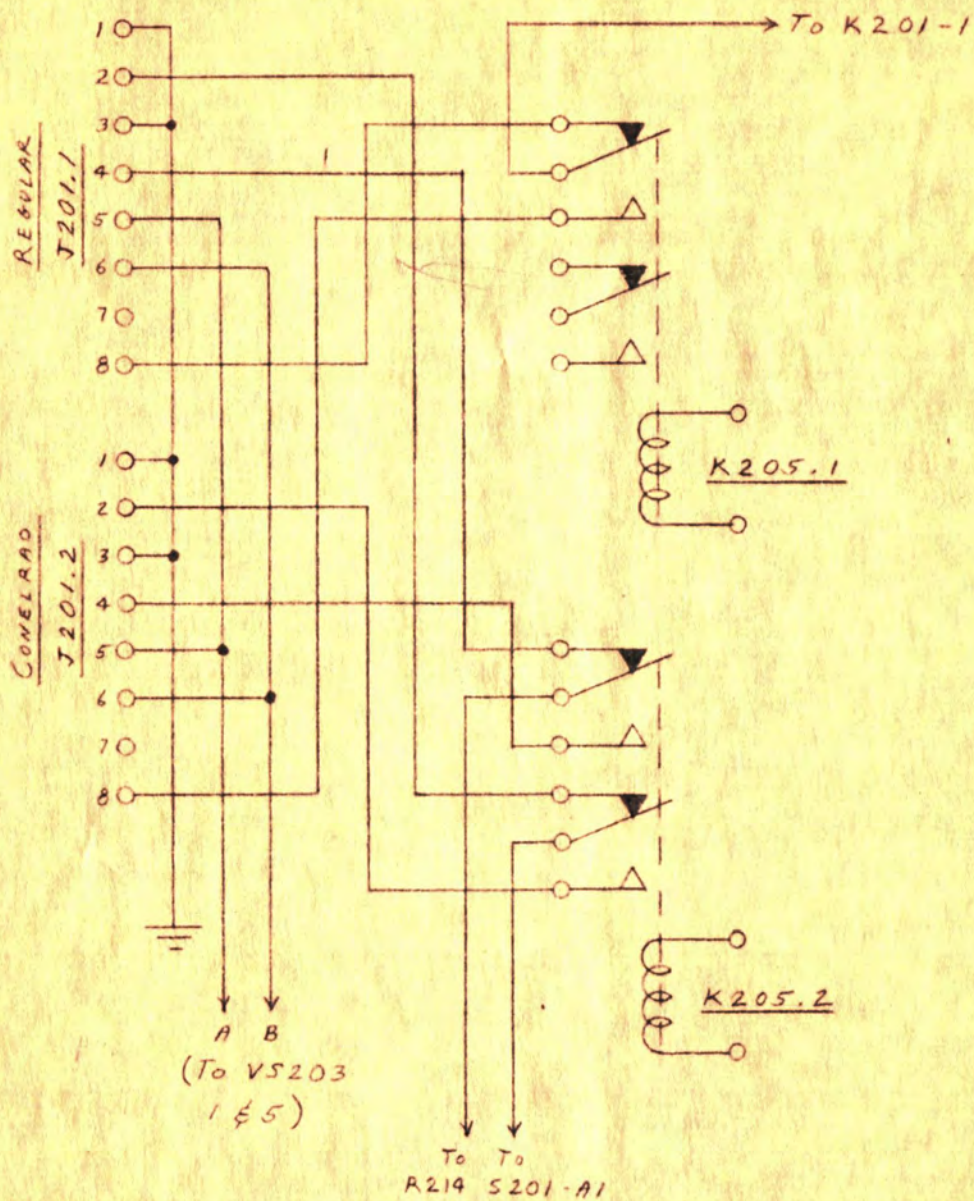

OSCILLATOR SWITCHING

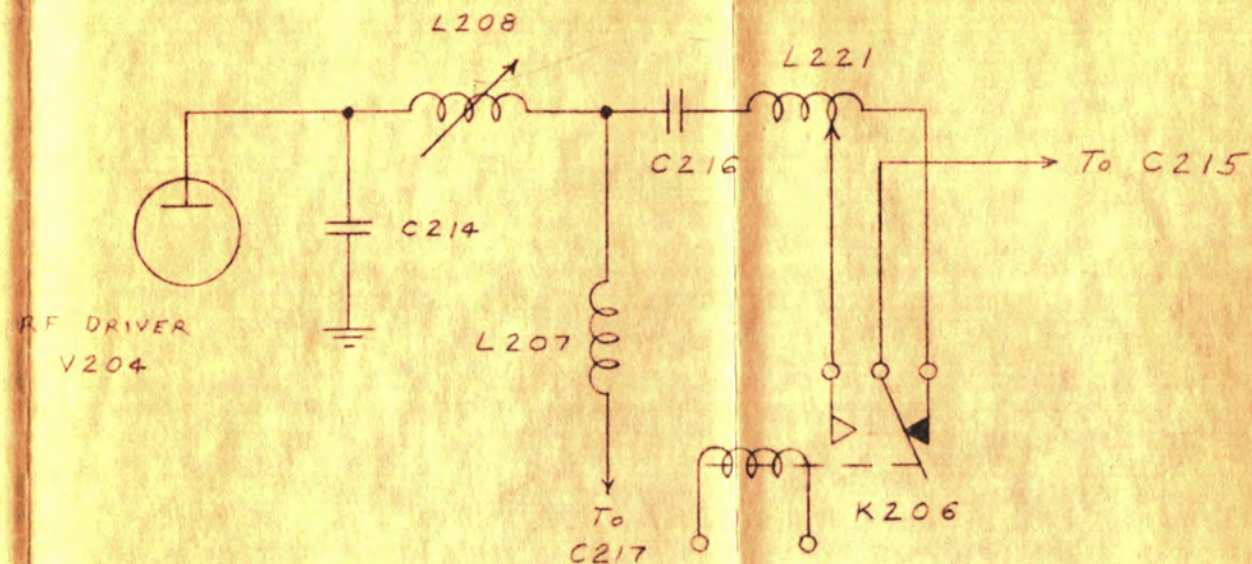

DRIVER PLATE CIRCUIT SWITCHING

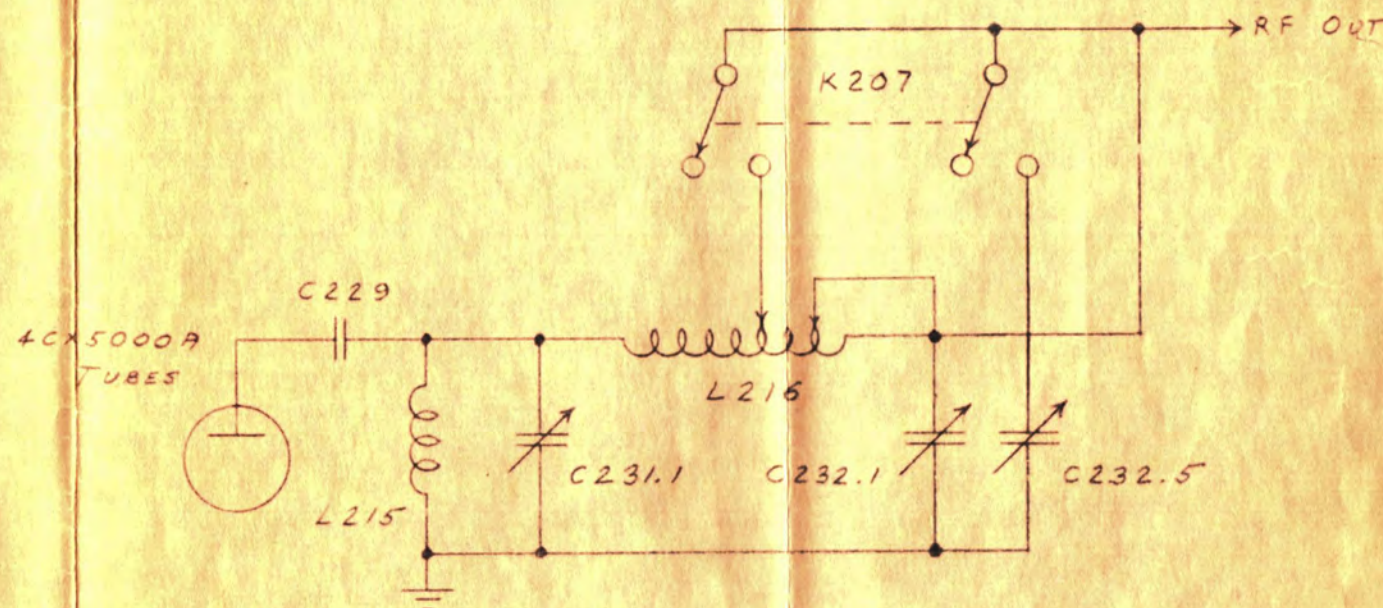

OUTPUT NETWORK SWITCHING

NOTE:

1. ALL RELAYS SHOWN IN "REGULAR" POSITION.
2. COIL TAPS, ETC. SHOWN FOR CASE WHEREIN CONELRAD FREQUENCY IS HIGHER THAN REGULAR FREQUENCY.

THESE DRAWINGS AND SPECIFICATIONS ARE THE PROPERTY OF CONTINENTAL ELECTRONICS MANUFACTURING COMPANY, INC., OF DALLAS, TEXAS AND SHALL NOT BE REPRODUCED, OR COPIED OR USED AS THE BASIS FOR THE MANUFACTURE OR SALE OF APPARATUS WITHOUT PERMISSION.

USED WITH
19001-E
19002-E
19947-B

MATL 2
FIN 2

UNLESS OTHERWISE SPECIFIED
DIMENSIONS IN INCHES
TOLERANCES
FRACT. DEC. ANG.
±1/64 ±.015 ±1/2°

SYM	REVISIONS	DATE	APP

CONTINENTAL ELECTRONICS MANUFACTURING CO.
DALLAS, TEXAS

CONTACT CONNECTIONS
CONELRAD FREQUENCY CHANGING
TYPE 315B/316B TRANSMITTER

SCALE: 1" = 1"

APP D.	ENG.	DRAWN

19948-B
14 SEP 59

If You Didn't Get This From My Site,
Then It Was Stolen From...
www.SteamPoweredRadio.Com

TENTATIVE DATA

4CX5000A

EITEL-McCULLOUGH, INC.
SAN BRUNO, CALIFORNIA

4X5000A

**RADIAL-BEAM
POWER TETRODE**

The Eimac 4X5000A is a compact high power forced-air-cooled tetrode of metal and ceramic construction. The 4X5000A is useful as an oscillator, amplifier or modulator at frequencies up to 30 megacycles at full ratings. Its characteristics make it particularly useful as a linear single-sideband amplifier, class AB₁ audio amplifier or as a screen-modulated radio-frequency amplifier.

A pair of these tubes will deliver 17.5 kilowatts of audio-frequency or radio-frequency power with zero driving power. The plate dissipation is rated at five kilowatts for most applications, and six kilowatts for Class-AB operation.

GENERAL CHARACTERISTICS

ELECTRICAL

Filament: Thoriated Tungsten			
Voltage	- - - - -	- - - - -	7.5 volts
Current	- - - - -	- - - - -	75 amperes
Grid-Screen Amplification Factor (Average)	- - - - -	- - - - -	5
Direct Interelectrode Capacitances (Average)		Grounded Cathode	Grounded Grid
Feedback	- - - - -	0.75 uuf	0.14 uuf
Input	- - - - -	106 uuf	47 uuf
Output	- - - - -	18 uuf	18 uuf
Highest Frequency for Maximum Ratings	- - - - -	- - - - -	30 mc



MECHANICAL

Base	- - - - -	- - - - -	- - - - -	Special, Concentric
Recommended Socket	- - - - -	- - - - -	- - - - -	Eimac SK-300
Mounting	- - - - -	- - - - -	- - - - -	Axis vertical, base down or up
Cooling	- - - - -	- - - - -	- - - - -	Forced Air
Maximum Over-all Dimensions:				
Length	- - - - -	- - - - -	- - - - -	9-1/8 inches
Diameter	- - - - -	- - - - -	- - - - -	4-15/16 inches
Net Weight	- - - - -	- - - - -	- - - - -	9 1/2 pounds
Shipping Weight (Approx.)	- - - - -	- - - - -	- - - - -	22 pounds

Note: Typical operation data are based on conditions of adjusting the r-f drive to a specified plate current, maintaining fixed conditions of grid bias and screen voltage. It will be found that if this procedure is followed, there will be little variation in power output between tubes even though there may be some variation in grid and screen currents. Where grid bias is obtained principally by means of a grid resistor, to control plate current it is necessary to make the resistor adjustable.

RADIO-FREQUENCY POWER AMPLIFIER AND OSCILLATOR

Class-C, Key-down conditions, per tube:

MAXIMUM RATINGS

D-C PLATE VOLTAGE	7500 MAX. VOLTS
D-C SCREEN VOLTAGE	1500 MAX. VOLTS
D-C PLATE CURRENT	3.0 MAX. AMPERES
PLATE DISSIPATION	5000 MAX. WATTS
SCREEN DISSIPATION	250 MAX. WATTS
GRID DISSIPATION	75 MAX. WATTS

TYPICAL OPERATION (Frequencies below 30 mc.)

D-C Plate Voltage	- - - - -	7500 volts
D-C Screen Voltage	- - - - -	500 volts
D-C Grid Voltage	- - - - -	-350 volts
D-C Plate Current	- - - - -	2.8 amperes
D-C Screen Current	- - - - -	0.5 amperes
D-C Grid Current	- - - - -	0.25 amperes
Peak R-F Grid Voltage	- - - - -	590 volts
Driving Power	- - - - -	150 watts
Grid Dissipation	- - - - -	60 watts
Screen Dissipation	- - - - -	250 watts
Plate Dissipation	- - - - -	5000 watts
Plate Power Output	- - - - -	16,000 watts

(Effective 6-1-56) Copyright, 1956 by Eitel-McCullough, Inc.

4CX5000A - \$450.00

PLATE-MODULATED RADIO-FREQUENCY POWER AMPLIFIER

Class-C Telephony, Carrier Conditions
unless otherwise specified, one tube:

MAXIMUM RATINGS

D-C PLATE VOLTAGE	5000 MAX. VOLTS
D-C SCREEN VOLTAGE	1000 MAX. VOLTS
D-C PLATE CURRENT	2.5 MAX. AMPERES
PLATE DISSIPATION*	3500 MAX. WATTS
SCREEN DISSIPATION	250 MAX. VOLTS
GRID DISSIPATION	75 MAX. WATTS

TYPICAL OPERATION, Frequencies below 30 mc.:

D-C Plate Voltage	-	-	-	-	-	-	-	-	5000 volts
D-C Screen Voltage	-	-	-	-	-	-	-	-	500 volts
D-C Grid Voltage	-	-	-	-	-	-	-	-	-400 volts
D-C Plate Current	-	-	-	-	-	-	-	-	1.4 amperes
D-C Screen Current	-	-	-	-	-	-	-	-	0.26 amperes
D-C Grid Current	-	-	-	-	-	-	-	-	0.050 amperes
Peak R-F Grid Voltage	-	-	-	-	-	-	-	-	520 volts
Grid Driving Power	-	-	-	-	-	-	-	-	25 watts
Grid Dissipation	-	-	-	-	-	-	-	-	6 watts
Screen Dissipation	-	-	-	-	-	-	-	-	130 watts
Plate Dissipation	-	-	-	-	-	-	-	-	1100 watts
Peak A-F Screen Voltage for 100% modulation	-	-	-	-	-	-	-	-	450 volts
Plate Power Output	-	-	-	-	-	-	-	-	5.8 kilowatts

*Corresponds to 5 kw at 100%, sine-wave modulation.

CLASS-AB RADIO-FREQUENCY OR AUDIO POWER AMPLIFIER

MAXIMUM RATINGS per tube:

D-C PLATE VOLTAGE	7500 MAX. VOLTS
D-C SCREEN VOLTAGE	1500 MAX. VOLTS
D-C PLATE CURRENT	4.0 MAX. AMPERES
PLATE DISSIPATION	6000 MAX. WATTS
SCREEN DISSIPATION	250 MAX. WATTS
GRID DISSIPATION	75 MAX. WATTS

TYPICAL OPERATION, Class-AB, R-F Linear Amplifier, one tube,

Peak Envelope or Modulation Crest Conditions,
Frequencies below 30 mc.:

D-C Plate Voltage	-	-	-	-	-	-	-	-	7500 volts
D-C Screen Voltage	-	-	-	-	-	-	-	-	1250 volts
D-C Grid Voltage*	-	-	-	-	-	-	-	-	-300 volts
D-C Plate Current	-	-	-	-	-	-	-	-	1.9 amperes
Zero-Signal Plate Current	-	-	-	-	-	-	-	-	0.50 amperes
D-C Screen Current	-	-	-	-	-	-	-	-	0.20 amperes
D-C Grid Current	-	-	-	-	-	-	-	-	0 amperes
Driving Power	-	-	-	-	-	-	-	-	0 watts
Peak R-F Grid Voltage	-	-	-	-	-	-	-	-	300 volts
Screen Dissipation	-	-	-	-	-	-	-	-	250 watts
Plate Dissipation	-	-	-	-	-	-	-	-	4200 watts
Plate Power Output**	-	-	-	-	-	-	-	-	10,000 watts

*Adjust grid voltage to obtain specified Zero-signal plate current.

**Peak envelope Power Output or R-F Power Output at crest of modulation envelope.

TYPICAL OPERATION, Class-AB, Audio Amplifier, two tubes unless otherwise specified:

D-C Plate Voltage	-	-	-	-	4000	5000	6000	7000	volts
D-C Screen Voltage	-	-	-	-	1250	1250	1250	1250	volts
D-C Grid Voltage	-	-	-	-	-270	-280	-310	-325	volts
D-C Zero-Signal Plate Current	-	-	-	-	1.25	1.00	0.83	0.70	amperes
D-C Max-Signal Plate Current	-	-	-	-	5.10	4.40	4.25	3.65	amperes
D-C Zero-Signal Screen Current	-	-	-	-	0	0	0	0	amperes
D-C Max-Signal Screen Current	-	-	-	-	0.35	0.33	0.30	0.24	amperes
Load Resistance, P-to-P	-	-	-	-	1500	2370	2940	4100	ohms
Peak A-F Driving Voltage	-	-	-	-	250	240	270	235	volts
Driving Power	-	-	-	-	0	0	0	0	watts
Max-Signal Plate Dissipation	-	-	-	-	4200	4200	4200	4200	watts
Max-Signal Power Output	-	-	-	-	11,500	13,500	17,000	17,500	watts

APPLICATION

MECHANICAL

Mounting—The 4X5000A must be mounted with its axis vertical. The base of the tube may be down or up at the convenience of the circuit designer.

Socket—The Eimac Air-System Socket Type SK-300 is designed especially for the concentric base terminals of the 4X5000A. The use of recommended air-flow rates through this socket provides effective forced-air cooling of the tube. Air forced into the bottom of the socket passes over the tube terminals, after which a duct guides it into the anode cooling fins.

Cooling—The maximum temperature rating for the external surfaces of the 4X5000A is 200°C. Sufficient forced air circulation must be provided to keep the temperature of the anode at the base of the cooling fins and the temperature of the ceramic stem surfaces below 200°C.

When the tube is mounted in the Eimac SK-300 Socket, plate dissipation power of 5,000 watts requires 175 CFM air flow, corresponding to a pressure differential across tube and socket of 1.5 inches water column. Cooling at the 6,000-watt dissipation power level requires 210 CFM air flow, corresponding to a pressure

differential of 2.25 inches water column across the tube and socket.

The flow rates and pressure differentials specified above apply to air at sea level pressure and at 20°C ambient temperature.

If the 4X5000A is operated in a socket of a design different from that of the SK-300, the air-flow rates must be determined independently for each design, using the maximum rated temperature as the criterion for satisfactory cooling.

A convenient method of measuring temperatures is the use of a temperature-sensitive paint, applied sparingly to the tube surfaces. When heavy coats are applied, the air-cooled surface of the paint may not reach the tube temperature because the paint conducts heat poorly and errors can occur. One type of temperature-sensitive paint can be obtained from the Tempil Corporation, 11 West 25th Street, New York, 10, N.Y.

The air inlet to the cooling system should be equipped with an effective air filter, which should be inspected periodically to assure adequate air flow into the system.

ELECTRICAL

Filament Operation—The rated filament voltage for the 4X5000A is 7.5 volts. The actual operating voltage should be maintained within the range from 7.15 to 7.85 volts, as measured at the base of the tube.

Electrode Dissipation Ratings—The maximum dissipation ratings for the 4X5000A must be respected to avoid damage to the tube. An exception is the plate dissipation, which may be permitted to rise above the maximum rating during brief periods, such as may occur during tuning.

Grid Dissipation—The grid dissipation can be determined approximately by use of the expression:

$$P_{gt} = e_{cmp} I_c$$

where: P_{gt} = Grid dissipation, watts;
 e_{cmp} = Peak grid-filament positive voltage, volts;
 I_c = D-C grid current, amperes.

The value of the peak positive grid voltage can be measured by means of a suitable peak-reading vacuum tube voltmeter.

Screen Dissipation—The screen dissipation, in cases where there is no a-c applied to the screen, is the simple product of the screen voltage and the screen current.

In case the screen voltage is modulated, the screen dissipation will depend strongly on the loading, driving power, and carrier screen voltage.

Plate Dissipation—The plate dissipation rating for the 4X5000A is 5000 watts for most applications, but for audio and SSB amplifier applications, the maximum dissipation rating is 6000 watts.

In class-AB and class-B amplifiers, the maximum plate dissipation does not coincide with maximum power output, but occurs at some lower power level determined jointly by the bias voltage and the driving voltage applied to the tube. Accordingly, it is advisable to limit the plate dissipation under full power conditions to approximately 70% of the maximum rated plate dissipation of the tubes used.

Screen modulated operation produces maximum plate dissipation under carrier conditions. The dissipation diminishes as the modulation increases.

When the 4X5000A is operated as a plate-modulated r-f power amplifier, the power input is limited by conditions not connected with the plate efficiency, which is quite high. Therefore, except during tuning there is little possibility that the 3500-watt maximum plate dissipation rating will be exceeded.

Special Applications—If it is desired to operate this tube under conditions widely different from those given here, write to Eitel-McCullough, Inc., San Bruno, California, for information and recommendations.

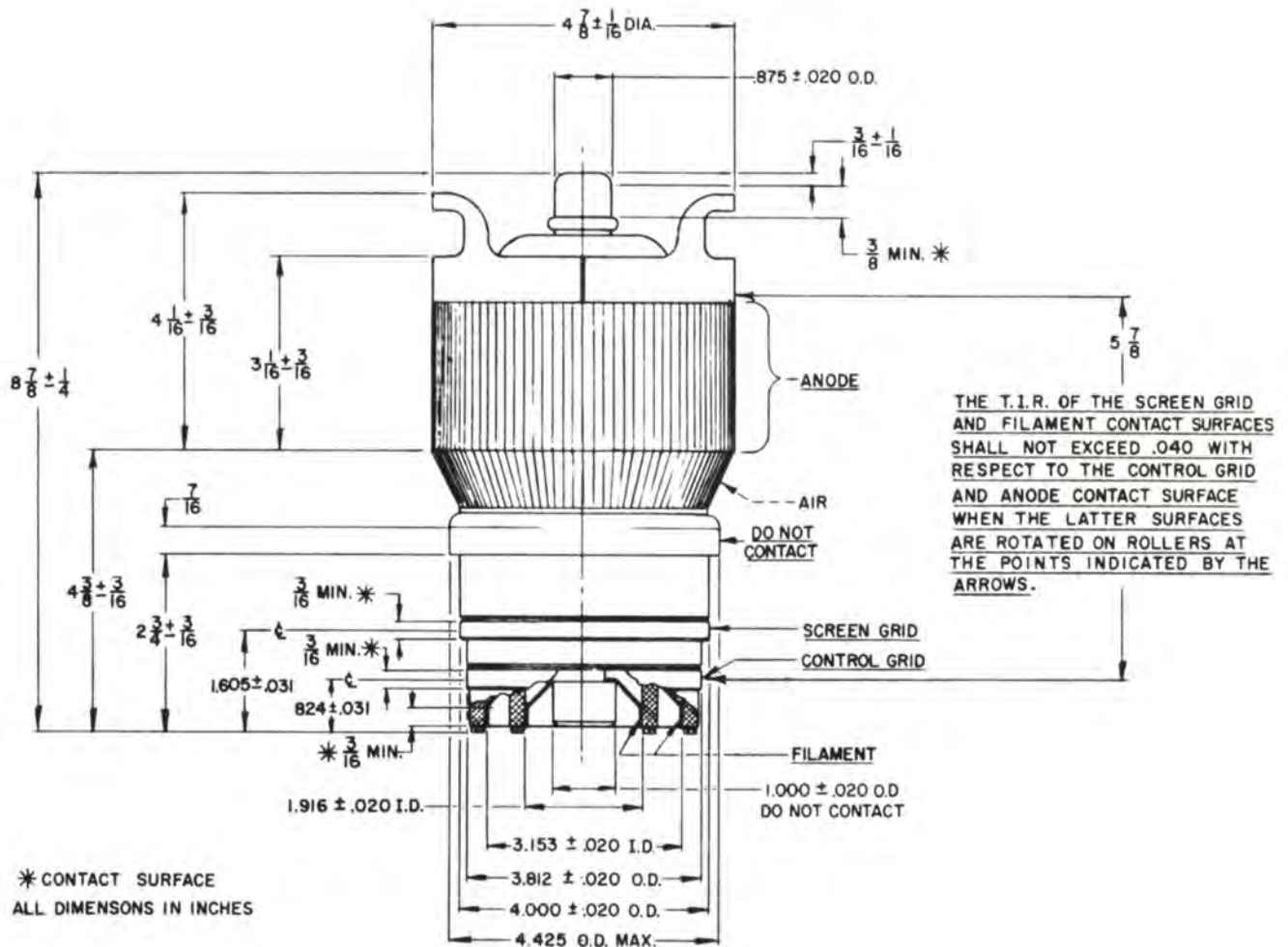

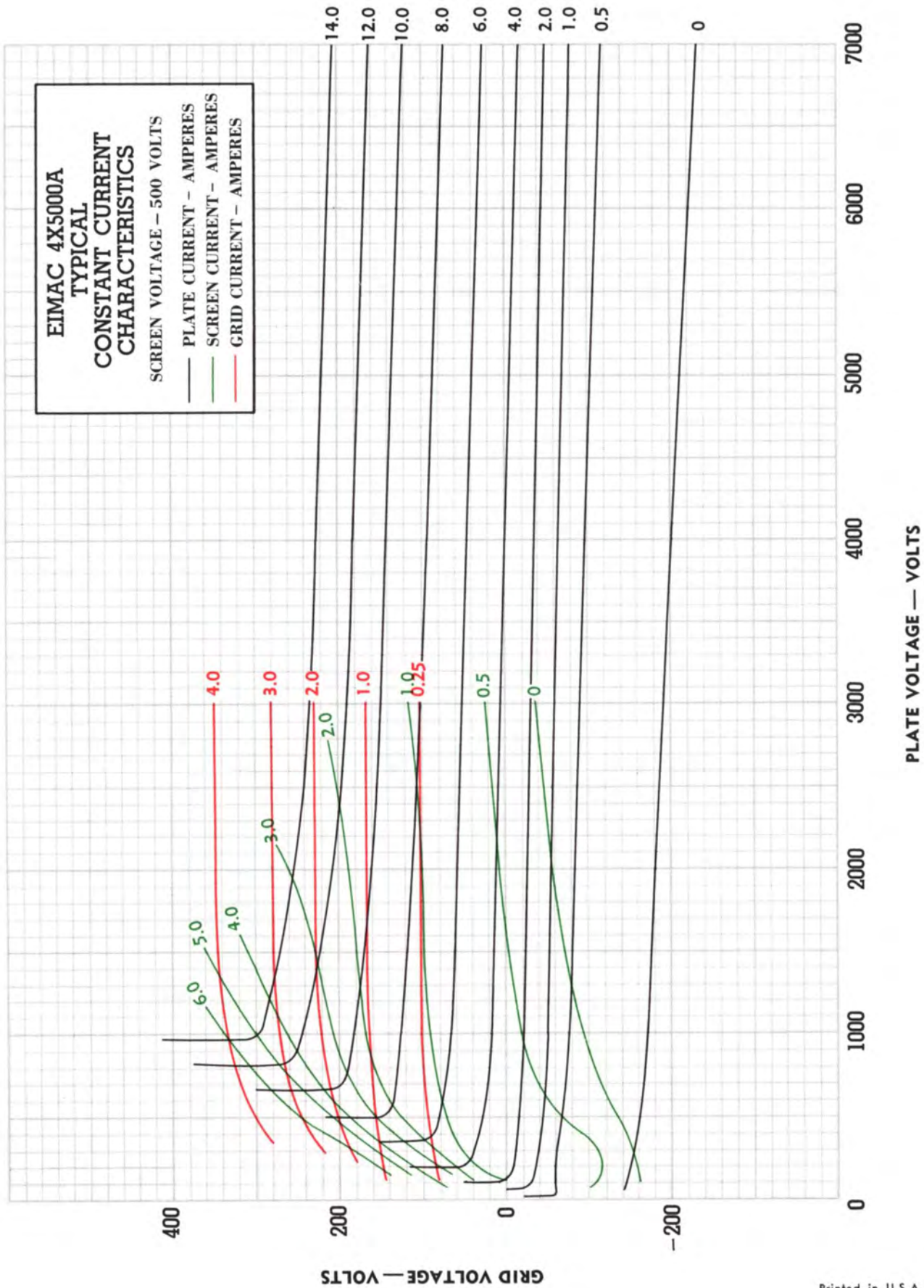



EITEL-McCULLOUGH, INC.
SAN BRUNO · CALIFORNIA

4-65A

RADIAL-BEAM
POWER TETRODE

MODULATOR
OSCILLATOR
AMPLIFIER

The Eimac 4-65A is a small radiation-cooled transmitting tetrode having a maximum plate-dissipation rating of 65 watts. The plate operates at a red color at maximum dissipation. Short, heavy leads and low interelectrode capacitances contribute to stable efficient operation at high frequencies.

Although it is capable of withstanding high plate voltages, the internal geometry of the 4-65A is such that it will deliver relatively high power output at a low plate voltage.

The quick-heating filament allows conservation of power during standby periods in mobile applications.

GENERAL CHARACTERISTICS

ELECTRICAL

Filament: Thoriated tungsten	
Voltage	6.0 volts
Current	3.5 amperes
Grid-Screen Amplification Factor (Average)	5
Direct Interelectrode Capacitances (Average)	
Grid-Plate	0.08 μf
Input	8.0 μf
Output	2.1 μf
Transconductance (Ib = 125 ma., Eb = 500 v., Ec ₂ = 250 v.)	4000 μmhos
Frequency for Maximum Ratings	150 Mc.

MECHANICAL

Base	5-pin—Fits	} National HX-29 Socket } Johnson 122-101 Socket
Mounting		
Cooling		} Vertical, base down or up
Recommended Heat Dissipating Connector		} Convection and Radiation
Maximum Over-all Dimensions		} Eimac HR-6
Length		4.38 inches
Diameter		2.38 inches
Net Weight		3 ounces
Shipping Weight		1.5 pounds



▶ **RADIO-FREQUENCY POWER AMPLIFIER AND OSCILLATOR**

Class-C Telegraphy or FM Telephony

MAXIMUM RATINGS (Key-down conditions, per tube)

D-C PLATE VOLTAGE	3000 MAX. VOLTS
D-C SCREEN VOLTAGE	400 MAX. VOLTS
D-C GRID VOLTAGE	-500 MAX. VOLTS
D-C PLATE CURRENT	150 MAX. MA
PLATE DISSIPATION	65 MAX. WATTS
SCREEN DISSIPATION	10 MAX. WATTS
GRID DISSIPATION	5 MAX. WATTS

TYPICAL OPERATION

D-C Plate Voltage	600	1000	1500	2000	3000	volts
D-C Screen Voltage	250	250	250	250	250	volts
D-C Grid Voltage	-75	-80	-85	-90	-100	volts
D-C Plate Current	150	150	150	140	115	ma
D-C Screen Current*	40	40	40	40	22	ma
D-C Grid Current*	18	17	18	11	10	ma
Peak R-F Grid Voltage	170	175	180	190	170	volts
Driving Power*	3.1	3.0	3.2	2.1	1.7	watts
Screen Dissipation*	10	10	10	10	5.5	watts
Plate Power Input	90	150	225	280	345	watts
Plate Dissipation	45	55	60	65	65	watts
Plate Power Output	45	95	165	215	280	watts

*Approximate values.

▶ **PLATE-MODULATED RADIO-FREQUENCY AMPLIFIER**

Class-C Telephony (Carrier conditions unless otherwise specified, 1 tube)

MAXIMUM RATINGS

D-C PLATE VOLTAGE	2500 MAX. VOLTS
D-C SCREEN VOLTAGE	400 MAX. VOLTS
D-C GRID VOLTAGE	-500 MAX. VOLTS
D-C PLATE CURRENT	120 MAX. MA
PLATE DISSIPATION	45 MAX. WATTS
SCREEN DISSIPATION	10 MAX. WATTS
GRID DISSIPATION	5 MAX. WATTS

TYPICAL OPERATION

D-C Plate Voltage	600	1000	1500	2000	2500	volts
D-C Screen Voltage	250	250	250	250	250	volts
D-C Grid Voltage	-120	-125	-125	-130	-135	volts
D-C Plate Current	120	120	120	120	110	ma
D-C Screen Current*	40	40	40	40	25	ma
D-C Grid Current*	15	16	16	16	12	ma
Screen Dissipation*	10	10	10	10	6.3	watts
Peak A-F Screen Voltage, 100% Modulation	250	250	250	250	250	volts
Peak R-F Grid Voltage	215	220	220	225	215	volts
Driving Power*	3.2	3.5	3.5	3.6	2.6	watts
Plate Power Input	72	120	180	240	275	watts
Plate Dissipation	27	30	40	45	45	watts
Plate Power Output	45	90	140	195	230	watts

*Approximate values.

Note: Typical operation data are based on conditions of adjusting the r-f grid drive to a specified plate current, maintaining fixed conditions of grid bias and screen voltage. It will be found that if this procedure is followed, there will be little variation in power output between tubes even though there may be some variation in grid and screen currents. Where grid bias is obtained principally by means of a grid resistor, to control plate current it is necessary to make the resistor adjustable.

AUDIO-FREQUENCY POWER AMPLIFIER AND MODULATOR

MAXIMUM RATINGS (PER TUBE)

D-C PLATE VOLTAGE	- - - - -	3000 MAX. VOLTS
D-C SCREEN VOLTAGE	- - - - -	600 MAX. VOLTS
MAX-SIGNAL D-C PLATE CURRENT, PER TUBE	- - - - -	150 MAX. MA
PLATE DISSIPATION, PER TUBE	- - - - -	65 MAX. WATTS
SCREEN DISSIPATION, PER TUBE	- - - - -	10 MAX. WATTS

TYPICAL OPERATION

Class-AB₁ (Sinusoidal wave, two tubes unless otherwise specified)

D-C Plate Voltage	- - - - -	1000	1500	1750	volts
D-C Screen Voltage	- - - - -	500	500	500	volts
D-C Grid Voltage ¹	- - - - -	-100	-110	-115	volts
Zero-Signal D-C Plate Current	- - - - -	60	60	40	ma
Max-Signal D-C Plate Current	- - - - -	170	180	170	ma
Max-Signal D-C Screen Current*	- - - - -	30	20	23	ma
Max-Signal D-C Grid Current	- - - - -	0	0	0	
Effective Plate-to-Plate Load	- - - - -	9000	15,000	20,000	ohms
Peak A-F Grid Voltage (per tube)	- - - - -	85	85	90	volts
Max-Signal Plate Power Input	- - - - -	170	270	300	watts
Max-Signal Plate Power Output	- - - - -	80	145	175	watts

*Approximate value.

¹Adjust to stated zero-signal D-C Plate Current.

The effective grid circuit resistance for each tube must not exceed 250,000 ohms.

TYPICAL OPERATION

Class-AB₂ (Sinusoidal wave, two tubes unless otherwise specified)

D-C Plate Voltage	- - - - -	600	1000	1500	1800	volts
D-C Screen Voltage	- - - - -	250	250	250	250	volts
D-C Grid Voltage**	- - - - -	-40	-40	-45	-50	volts
Zero-Signal D-C Plate Current	- - - - -	60	60	60	50	ma
Max-Signal D-C Plate Current	- - - - -	300	300	250	220	ma
Max-Signal D-C Screen Current*	- - - - -	80	60	40	30	ma
Effective Plate-to-Plate Load	- - - - -	3600	6800	14,000	20,000	ohms
Peak A-F Grid Voltage (per tube)	- - - - -	120	105	100	90	volts
Max-Signal Peak Driving Power*	- - - - -	7.4	6.0	3.8	2.6	watts
Max-Signal Nominal Driving Power*	- - - - -	3.7	3.0	1.9	1.3	watts
Max-Signal Plate Power Input	- - - - -	180	300	375	395	watts
Max-Signal Plate Power Output	- - - - -	90	170	250	270	watts

*Approximate values.

**Adjust to stated Zero-Signal D-C Plate Current.

RADIO-FREQUENCY LINEAR POWER AMPLIFIER SINGLE SIDE BAND SUPPRESSED CARRIER

Class-B (One tube)

MAXIMUM RATINGS

D-C PLATE VOLTAGE	- - - - -	3000 MAX. VOLTS
D-C SCREEN VOLTAGE	- - - - -	600 MAX. VOLTS
PLATE DISSIPATION	- - - - -	65 MAX. WATTS
SCREEN DISSIPATION	- - - - -	10 MAX. WATTS
GRID DISSIPATION	- - - - -	5 MAX. WATTS

*Adjust to stated Zero-Signal Plate Current.

**Approximate values.

***Due to the intermittent nature of voice, average dissipation is considerably less than Max-Signal Dissipation. If the amplifier is to be tested using a sine-wave signal source, arrangements must be made to lower the duty.

TYPICAL OPERATION

Class-AB₂ (Voice wave only, per tube)

D-C Plate Voltage	- - - - -	1500	2000	2500	volts
D-C Screen Voltage	- - - - -	300	400	500	volts
D-C Grid Voltage*	- - - - -	-55	-80	-105	volts
Zero-Signal D-C Plate Current	- - - - -	35	25	20	ma
Max-Signal D-C Plate Current	- - - - -	200	270	230	ma
Max-Signal D-C Screen Current**	- - - - -	45	65	45	ma
Max-Signal Peak R-F Grid Voltage	- - - - -	150	190	165	volts
Max-Signal D-C Grid Current**	- - - - -	15	20	8	ma
Max-Signal Driving Power**	- - - - -	2.3	3.8	1.3	watts
Max-Signal Plate Power Input	- - - - -	300	540	575	watts
Max-Signal Plate Dissipation***	- - - - -	105	190	225	watts
Average Plate Dissipation	- - - - -	60	65	65	watts
Max-Signal Useful Power Output	- - - - -	150	300	325	watts

IF IT IS DESIRED TO OPERATE THIS TUBE UNDER CONDITIONS WIDELY DIFFERENT FROM THOSE GIVEN UNDER "TYPICAL OPERATIONS," POSSIBLY EXCEEDING MAXIMUM RATINGS, WRITE EITEL-McCULLOUGH, INC., FOR INFORMATION AND RECOMMENDATIONS.

APPLICATION

MECHANICAL

Mounting—The 4-65A must be mounted vertically, base up or base down. The socket must provide clearance for the glass tip-off which extends from the center of the base. A flexible connecting strap should be provided between the plate terminal and the external plate circuit, and the Eimac HR-6 cooler (or equivalent) used on the tube plate lead. The socket must not apply lateral pressure against the base pins. The tube must be protected from severe vibration and shock.

Adequate ventilation must be provided so that the seals and envelope under operating conditions do not exceed 225°C. For operation above 50 Mc., the plate voltage should be reduced, or special attention should be given to seal cooling.

In intermittent-service applications where the "on" time does not exceed a total of five minutes in any ten minute period, plate seal temperatures as high as 250°C are permissible. When the ambient temperature does not exceed 30°C it will not ordinarily be necessary to provide forced cooling of the bulb and plate seal to hold the temperature below this maximum at frequencies below 50 Mc, provided that a heat-radiating plate connector is used, and the tube is so located that normal circulation of air past the envelope is not impeded.

ELECTRICAL

Filament Voltage—The filament voltage, as measured directly at the filament pins, should be between 5.7 volts and 6.3 volts.

Bias Voltage—D-C bias voltage for the 4-65A should not exceed -500 volts. If grid-leak bias is used, suitable protective means must be provided to prevent excessive plate or screen dissipation in the event of loss of excitation.

Grid Dissipation—Grid dissipation for the 4-65A should not be allowed to exceed five watts. Grid dissipation may be calculated from the following expression:

$$P_g = e_{cpl} I_c$$

where P_g = Grid dissipation,
 e_{cpl} = Peak positive grid voltage, and
 I_c = D-c grid current.

e_{cpl} may be measured by means of a suitable peak voltmeter connected between filament and grid.*

Screen Voltage—The D-C screen voltage for the 4-65A should not exceed 400 volts except in the case of class-AB audio operation and Single Side Band R-F amplifier operation where it should not exceed 600 volts.

Screen Dissipation—The power dissipated by the screen of the 4-65A must not exceed 10 watts. Screen dissipation is likely to rise to excessive values when the plate volt-

age, bias voltage or plate load is removed with filament and screen voltages applied. Suitable protective means must be provided to limit screen dissipation to 10 watts in the event of circuit failure.

Plate Voltage—The plate-supply voltage for the 4-65A should not exceed 3,000 volts. Above 50 Mc. it is advisable to use a lower plate voltage than the maximum, since the seal heating due to R-F charging currents in the screen leads increases with plate voltage and frequency. See instructions on seal cooling under "Mechanical" and "Shielding."

Plate Dissipation—Under normal operating conditions, the plate dissipation of the 4-65A should not be allowed to exceed 65 watts in unmodulated applications.

In high-level-modulated amplifier applications, the maximum allowable carrier-condition plate dissipation is 45 watts.

Plate dissipation in excess of maximum rating is permissible for short periods of time, such as during tuning procedures.

OPERATION

Class-C FM or Telegraphy—The 4-65A may be operated as a class-C FM or telegraph amplifier without neutralization up to 110 Mc. if reasonable precautions are taken to prevent coupling between input and output circuits external to the tube. In single ended circuits, plate, grid, filament and screen by-pass capacitors should be returned through the shortest possible leads to a common chassis point. In push-pull applications the filament and screen terminals of each tube should be by-passed to a common chassis point by the shortest possible leads, and short, heavy leads should be used to interconnect the screens and filaments of the two tubes. Care should be taken to prevent leakage of radio-frequency energy to leads entering the amplifier, in order to minimize grid-plate coupling between these leads external to the amplifier.

Where shielding is adequate, the feedback at frequencies above 110 Mc. is due principally to screen-lead-inductance effects, and it becomes necessary to introduce in-phase voltage from the plate circuit into the grid circuit. This can be done by adding capacitance between plate and grid external to the tube. Ordinarily, a small metal tab approximately 3/4" square and located adjacent to the envelope opposite the plate will suffice for neutralization. Means should be provided for adjusting the

*For suitable peak V.T.V.M. circuits see, for instance, Vacuum Tube Ratings," Eimac News, January 1945. This article is available in reprint form on request.

spacing between the neutralizing capacitor plate and the envelope. An alternate neutralization scheme for use above 110 Mc is illustrated in the diagram on page 4. In this circuit, feedback is eliminated by series-tuning the screen to ground with a small capacitor. The socket screen terminals should be strapped together as shown on the diagram, by the shortest possible lead, and the lead from the mid point of this screen strap to the capacitor, C, and from the capacitor to ground should be made as short as possible.

Driving power and power output under maximum output and plate voltage conditions are shown below. The power output shown is the actual plate power delivered by the tube; the power delivered to the load will depend upon the efficiency of the plate tank and output coupling system. The driving power is likewise the driving power required by the tube (includes bias loss). The driver output power should exceed the driving power requirements by a sufficient margin to allow for coupling-circuit losses. The use of silver-plated linear tank-circuit elements is recommended for all frequencies above 75 Mc.

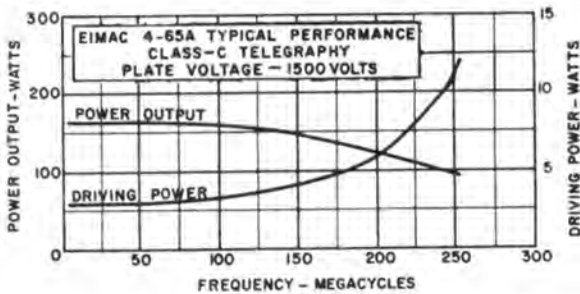

Class-C AM Telephony—The R-F circuit considerations discussed above under Class-C FM or Telegraphy also apply to amplitude-modulated operation of the 4-65A. When the 4-65A is used as a class-C high-level-modulated

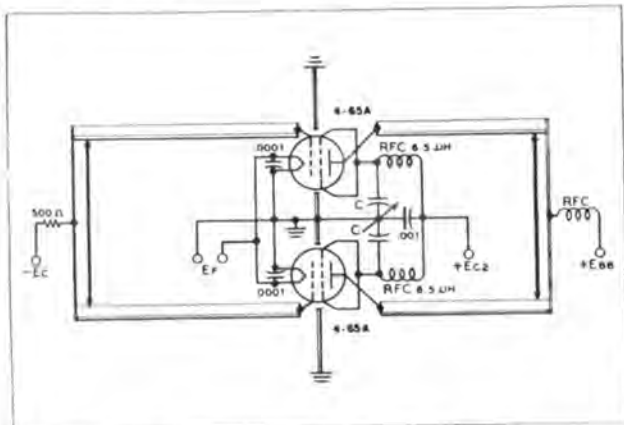

Screen-tuning neutralization circuit for use above 100 Mc. C is a small split-stator capacitor.

$$C(\mu\text{fd}) = \frac{640,000}{f^2 (\text{Mc.})}, \text{ approx.}$$

amplifier, both the plate and screen should be modulated. Modulation voltage for the screen is easily obtained by supplying the screen voltage via a series dropping resistor from the unmodulated plate supply, or by the use of an audio-frequency reactor in the positive screen-supply lead, or from a separate winding on the modulation transformer. When screen modulation is obtained by either the series-resistor or the audio-reactor methods, the audio-frequency variations in screen current which result from the variations in plate voltage as the plate is modulated automatically give the required screen modulation. Where a reactor is used, it should have a rated inductance of not less than 10 henries divided by the number of tubes in the modulated amplifier and a maximum current rating of two to three times the operating D-C screen current. To prevent phase-shift between the screen and plate modulation voltages at high audio frequencies, the screen by-pass capacitor should be no larger than necessary for adequate R-F by-passing.

For high-level modulated service, the use of partial grid-leak bias is recommended. Any by-pass capacitors placed across the grid-leak resistance should have a reactance at the highest modulation frequency equal to at least twice the grid-leak resistance.

Class-AB₁ and Class-AB₂ Audio—Two 4-65As may be used in a push-pull circuit to give relatively high audio output power at low distortion. Maximum ratings and typical operating conditions for class-AB₁ and class-AB₂ audio operation are given in the tabulated data.

Screen voltage should be obtained from a source having reasonably good regulation, to prevent variations in screen voltage from zero-signal to maximum-signal conditions. The use of voltage regulator tubes in a standard circuit should provide adequate regulation.

Grid bias voltage for class-AB₂ service may be obtained from batteries or from a small fixed-bias supply. When a bias supply is used, the D-C resistance of the bias source should not exceed 250 ohms. Under class-AB₁ conditions the effective grid-circuit resistance should not exceed 250,000 ohms.

The peak driving power figures given in the class-AB₂ tabulated data are included to make possible an accurate determination of the required driver output power. The driver amplifier must be capable of supplying the peak driving power without distortion. The driver stage should, therefore, be capable of providing an undistorted average output equal to half the peak driving power requirement. A small amount of additional driver output should be provided to allow for losses in the coupling transformer.

In some cases the maximum-signal plate dissipation shown under "Typical Operation" is less than the maximum rated plate dissipation of 4-65A. In these cases, with sine wave modulation, the plate dissipation reaches a maximum value, equal to the maximum rating, at a

point somewhat below maximum-signal conditions.

The power output figures given in the tabulated data refer to the total power output from the amplifier tubes. The useful power output will be from 5 to 15 per cent less than the figures shown, due to losses in the output transformer.

Because of the intermittent nature of the voice, and the low average power, it is possible in cases where size and weight are important to operate a class-AB stage at higher peak power values than those indicated for sine wave.

In order to obtain peak power above that shown for sine wave (peak is twice average for sine wave), the plate-to-plate load impedance must be made proportionately lower than the value shown for a particular plate voltage. Also, more peak driving power will be required. At no time should the average plate or grid dissipation exceed the maximum values shown.

KEYING THE TETRODE AMPLIFIER

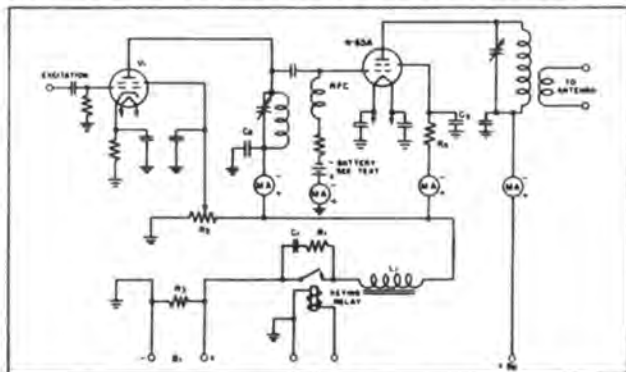

Tetrode Keying Circuit

The flow of plate current in an R-F tetrode amplifier depends not only on the control grid bias and excitation, but also on the voltage applied to the screen grid.

One easy method of keying is to remove the excitation and screen grid voltage simultaneously, while leaving the plate voltage still applied to the amplifier stage. This method also has an advantage in that the final tube can be made to draw a safe amount of current key-up position, maintaining a steadier drain on the power supply while keying. This tends to minimize "blinking lights" on weak AC supply lines when using moderate power. By properly choosing the values of L, C, and R, in the circuit, perfectly clean-cut highest speed hand keying can easily be obtained that is entirely devoid of clicks.

The keying circuit is shown in the diagram and V₁ is the driver tube, which may be any one of the small tetrodes such as an 807, 2E26, 6146, 6L6 or 6AG7, used either as a frequency multiplier or a straight-through amplifier. This tube should furnish about five watts of

output power which allows ample driving power for one 4-65A, including circuit losses. Capacitance coupling is shown in the diagram, but this, of course, could just as well be link coupling.

Steady driving power is fed to the grid of V₁ from the exciter. The keying circuit controls the plate and screen voltages on V₁, as well as the screen voltage on the 4-65A, all obtained from a common power supply B₁. This supply should furnish sufficient voltage to the plate of V₁ to obtain the necessary driving power. Normally this voltage will be about the correct voltage for the screen of the 4-65A and resistor R₄ may be omitted.

When the key is up there is no excitation to the 4-65A, and consequently no grid leak bias. At the same time, the screen voltage has also been removed so that very little current is drawn by the plate. With plate voltages up to 2000 volts, the amount of current drawn is not sufficient to heat the plate beyond its rated plate dissipation and a fixed bias is not required. However, with plate voltages over 2000 volts, a small fixed bias supply is needed to keep the plate dissipation within the rated limit. An ordinary 22½ volt C battery in the control grid circuit will furnish sufficient bias to completely cut the plate current off at 3000 volts, while some lower value of bias can be used to permit a safe amount of current to flow in key-up position, presenting a more constant load to the power supply.

A tapped resistor R₂ serves to supply screen voltage to V₁ and by adjusting this tap, the excitation to the 4-65A may be easily controlled. This method of controlling the output of a tetrode is not recommended in the larger tetrodes, however, as it is wasteful of power and the lowered power output obtained is due to a loss in efficiency. R₂ also serves as a means of keeping the screen of the 4-65A at ground potential under key-up conditions, stabilizing the circuit. R₃ is the normal power supply bleeder.

The keying relay must be insulated to withstand the driver plate voltage. Key clicks may be completely eliminated by the proper selection of L₁, R₁ and C₁ in series with and across the relay. In many applications values of 500 ohms for R₁ and 0.25 μfd for C₁ have been found entirely satisfactory. Choke L₁ is best selected by trial and usually is on the order of 5 henries. A satisfactory choke for this purpose can be made by using any small power-supply choke, capable of handling the combined current of the final screen grid and the driver stage, and adjusting the air gap to give the proper inductance. This may be checked by listening for clean keying on the "make" side of the signal or by observation in a 'scope.

R-F by-pass condensers C₂ and C₃ will have some effect on the required value of L₁ as well as C₁. These by-pass condensers should be kept at as small a value of capacity as is needed. In most cases .002 μfd is sufficient.



SHIELDING

The internal feedback of the tetrode has been substantially eliminated, and in order to fully utilize this advantage, it is essential that the design of the equipment completely eliminates any feedback external to the tube. This means complete shielding of the output circuit from the input circuit and earlier stages, proper reduction to low values of the inductance of the screen lead to the R-F ground, and elimination of R-F feedback in any common power supply leads.

Complete shielding is easily achieved by mounting the socket of the tube flush with the deck of the chassis as shown in the sketch on page 7.

The holes in the socket permit the flow of convection air currents from below the chassis up past the seals in the base of the tube. This flow of air is essential to cool the tube and in cases where the complete under part of the chassis is enclosed for electrical shielding, screened holes or louvers should be provided to permit air circulation. Note that shielding is completed by aligning the internal screen shield with the chassis deck and by proper R-F by-passing of the screen leads to R-F ground. The plate and output circuits should be kept above deck and the input circuit and circuits of earlier stages should be kept below deck or completely shielded.

DIFFERENT SCREEN VOLTAGES

The published characteristic curves of tetrodes are shown for the commonly used screen voltages. Occasionally it is desirable to operate the tetrode at some screen voltage other than that shown on the characteristic curves. It is a relatively simple matter to convert the published curves to corresponding curves at a different screen voltage by the method to be described.

This conversion method is based on the fact that if all inter-electrode voltages are either raised or lowered by the same relative amount, the shape of the voltage field pattern is not altered, nor will the current distribution be altered; the current lines will simply take on new proportionate values in accordance with the three-halves power law. This method fails only where insufficient cathode emission or high secondary emission affect the current values.

For instance, if the characteristic curves are shown at a screen voltage of 250 volts and it is desired to determine conditions at 500 screen volts, all voltage scales should be multiplied by the same factor that is applied to the screen voltage (in this case—2). The 1000 volt plate voltage point now becomes 2000 volts, the 50 volt grid voltage point, 100 volts, etc.

The current lines then all assume new values in accordance with the $3/2$ power law. Since the voltage was increased by a factor of 2, the current lines will all be increased in value by a factor of $2^{3/2}$ or 2.8. Then all the current values should be multiplied by the factor 2.8. The 100 ma. line becomes a 280 ma. line, etc.

Likewise, if the screen voltage given on the characteristic curve is higher than the conditions desired, the voltages should all be reduced by the same factor that is used to obtain the desired screen voltage. Correspond-

ingly, the current values will all be reduced by an amount equal to the $3/2$ power of this factor.

For convenience the $3/2$ power of commonly used factors is given below:

Voltage Factor	.25	.5	.75	1.0	1.25	1.50	1.75
Corresponding							
Current Factor	.125	.35	.65	1.0	1.4	1.84	2.3
Voltage Factor	2.0	2.25	2.5	2.75	3.0		
Corresponding							
Current Factor	2.8	3.4	4.0	4.6	5.2		

SINGLE SIDE BAND SUPPRESSED CARRIER OPERATION

The 4-65A may be operated as a class B linear amplifier in SSSC operation and peak power outputs of over 300 watts per tube may be readily obtained. This is made possible by the intermittent nature of the voice. If steady audio sine wave modulation is used, the single side band will be continuous and the stage will operate as a C-W class-B amplifier. With voice modulation the average power will run on the order of $1/5$ th of this continuous power.

The same precautions regarding shielding, coupling between input and output circuits, and proper R-F by-passing must be observed, as described under Class-C Telegraphy Operation.

Due to the widely varying nature of the load imposed on the power supplies by SSSC operation, it is essential that particular attention be given to obtaining good regulation in these supplies. The bias supply especially, should have excellent regulation, and the addition of a heavy bleeder to keep the supply well loaded will be found helpful.

Under conditions of zero speech signal, the operating bias is adjusted so as to give a plate dissipation of 50 watts at the desired plate and screen voltages. Due to the intermittent nature of voice, the average plate dissipation will rise only slightly under full speech modulation to approximately 65 watts. At the same time, however, the peak speech power output of over 300 watts is obtained.

SSSC TUNING PROCEDURE

Tuning the SSSC transmitter is best accomplished with the aid of an audio frequency oscillator and a cathode-ray oscilloscope. The audio oscillator should be capable of delivering a sine wave output of a frequency of around 800 to 1000 cycles so that the frequency will be somewhere near the middle of the pass-band of the audio system. Since successful operation of the class-B stage depends on good linearity and the capability of delivering full power at highest audio levels, the final tuning should be made under conditions simulating peak modulation conditions. If a continuous sine wave from the audio oscillator is used for tuning purposes, the average power at full modulation would be about five times that of speech under similar conditions of single side band operation and the final amplifier would be subjected to a heavy overload. One method of lowering the duty cycle of the audio oscillator to closer approxi-

mate speech conditions would be to modulate the oscillator with a low frequency.

An alternate method would be to use the continuous audio sine wave, making all adjustments at half voltages and half currents on the screen and plate, thus reducing the power to one quarter. The stand-by plate dissipation under these conditions should be set at about 10 watts. Following these adjustments, minor adjustments at full voltages and 50 watts of stand-by plate dissipation could then be made, but only allowing the full power to remain on for ten or fifteen second intervals.

The first step is to loosely couple the oscilloscope to the output of the exciter unit. The final amplifier with its filament and bias voltages turned on should also be coupled to the exciter at this time. With the audio oscillator running, adjust the exciter unit so that it delivers double side band signals. Using a linear sweep on the oscilloscope, the double side band pattern will appear on the screen the same as that obtained from a 100% sine wave modulated AM signal. Next vary the audio gain control so that the exciter can be checked for linearity. When the peaks of the envelope start to flatten out the upper limit of the exciter output has been reached and the maximum gain setting should be noted. The coupling to the final stage should be varied during this process and a point of optimum coupling determined by watching the oscilloscope pattern and the grid meter in the final stage.

Next, adjust the exciter for single side band operation and if it is working properly, the pattern on the oscilloscope will resemble an unmodulated AM carrier. The phasing controls should be adjusted so as to make the envelope as smooth on the top and bottom as possible. If the above conditions are satisfied, the exciter unit can be assumed to be operating satisfactorily.

Next, loosely couple the oscilloscope link to the output of the final amplifier and again adjust the exciter unit to give double side band output.

If the reduced duty cycle method is used, the following tuning procedure may be followed:

1. Cut the audio output to zero.
2. Apply 120 volts of bias to the 4-65A control grid.
3. Apply the operating plate voltage followed by the operating screen voltage.
4. Reduce bias voltage to obtain 50 watts of stand-by plate dissipation.
5. Increase audio gain, checking the oscilloscope pattern for linearity as in the case of the exciter, and adjust for optimum antenna coupling.
6. Re-adjust exciter unit for single side band operation.
7. Disconnect test signal and connect microphone.
8. Adjust the audio gain so that the voice peaks give the same deflection on the oscilloscope screen as was obtained from the test signal peaks.

If the alternate method is used with a 100% duty cycle from the audio oscillator, then step 3 should be to apply half voltages and the stand-by plate dissipation should be set at 10 watts.

After the audio oscillator is disconnected and step 8 completed at half voltages, the full voltages can then be applied and the stand-by plate dissipation adjusted for 50 watts.

It is essential that the microphone cable be well shielded and grounded to avoid R-F feedback that might not occur when the lower impedance audio oscillator is used as an audio source.

Typical operational data are given for SSSC in the first part of this data sheet.

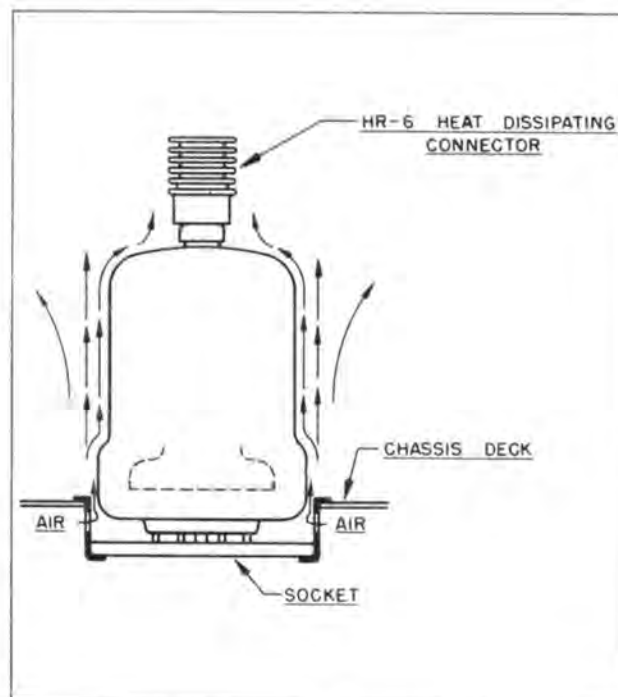

COMPONENTS FOR TYPICAL CIRCUITS

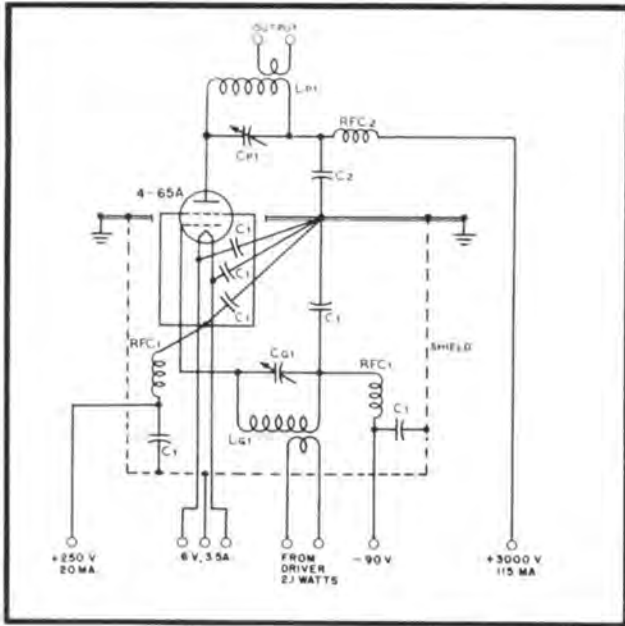

Typical radio-frequency power amplifier circuit, Class-C telegraphy, 345 watts input.

- L_{p1} - C_{p1} —Tank circuit appropriate for operating frequency; $Q=12$. Capacitor plate spacing=.200".
- L_{p2} - C_{p2} —Tank circuit appropriate for operating frequency; $Q=12$. Capacitor plate spacing=.200".
- L_{p3} - C_{p3} —Tank circuit appropriate for operating frequency; $Q=12$. Capacitor plate spacing=.375".
- L_{g1} - C_{g1} —Tuned circuit appropriate for operating frequency.
- L_{g2} - C_{g2} —Tuned circuit appropriate for operating frequency.
- C_1 —.002- μ fd. 500V Mica
- C_2 —.002- μ fd. 5000V Mica
- C_3 —.001- μ fd. 2500V Mica
- C_4 —.1- μ fd. 1000V paper
- C_5 —.1- μ fd. 600 V paper
- C_6 —16- μ fd. 450V Electrolytic
- C_7 —10- μ fd. 100V Electrolytic
- R_1 —53,000 ohms 200 watt—60,000 ohm adjustable
- R_2 —250,000 ohms 1 watt
- R_3 —5,000 ohms 5 watt
- R_4 —25,000 ohms 2 watts
- R_5 —26,500 ohms 200 watts—30,000 ohm adjustable
- R_6 —2,500 ohms 5 watts
- R_7 —750 ohms 5 watts
- RFC1—2.5 mhy. 125 ma. R-F choke
- RFC2—1 mhy. 500 ma. R-F choke
- T1—150 watt modulation transformer; ratio primary to secondary impedance approx. 1:1.1 Pri. impedance 15,000 ohms, sec. impedance 16,700 ohms.
- T2—5 watt driver transformer impedance ratio primary to 1/2 secondary 1.5:1.
- T3—300 watt modulation transformer; impedance ratio pri. to sec. approx. 2.4:1; Pri. impedance=20,000 ohms, sec. impedance=8,333 ohms.

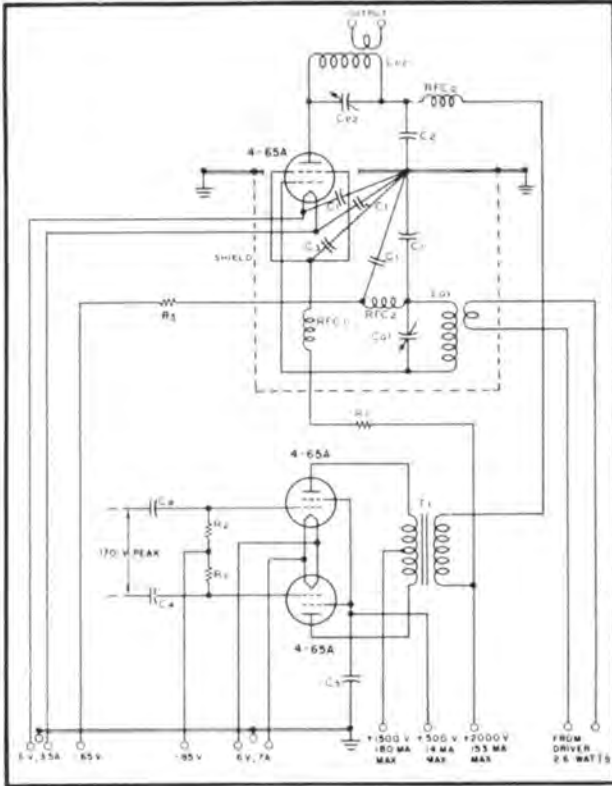

Typical high-level-modulated R-F amplifier, 240 watts plate input. Modulator requires zero driving power.

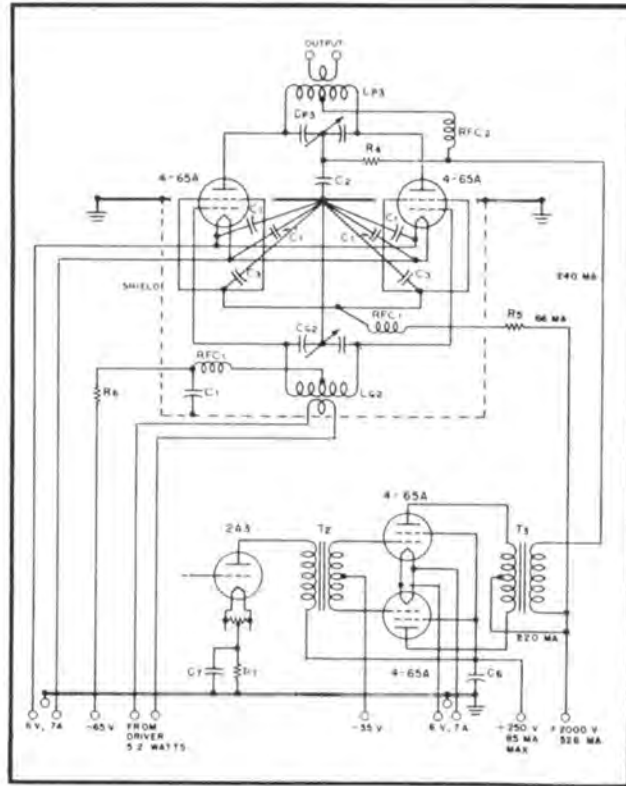

Typical high-level-modulated R-F amplifier circuit, with modulator and driver stages, 480 watts plate input.

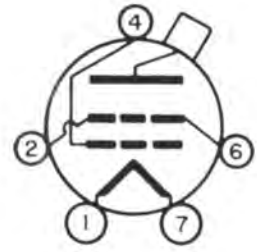
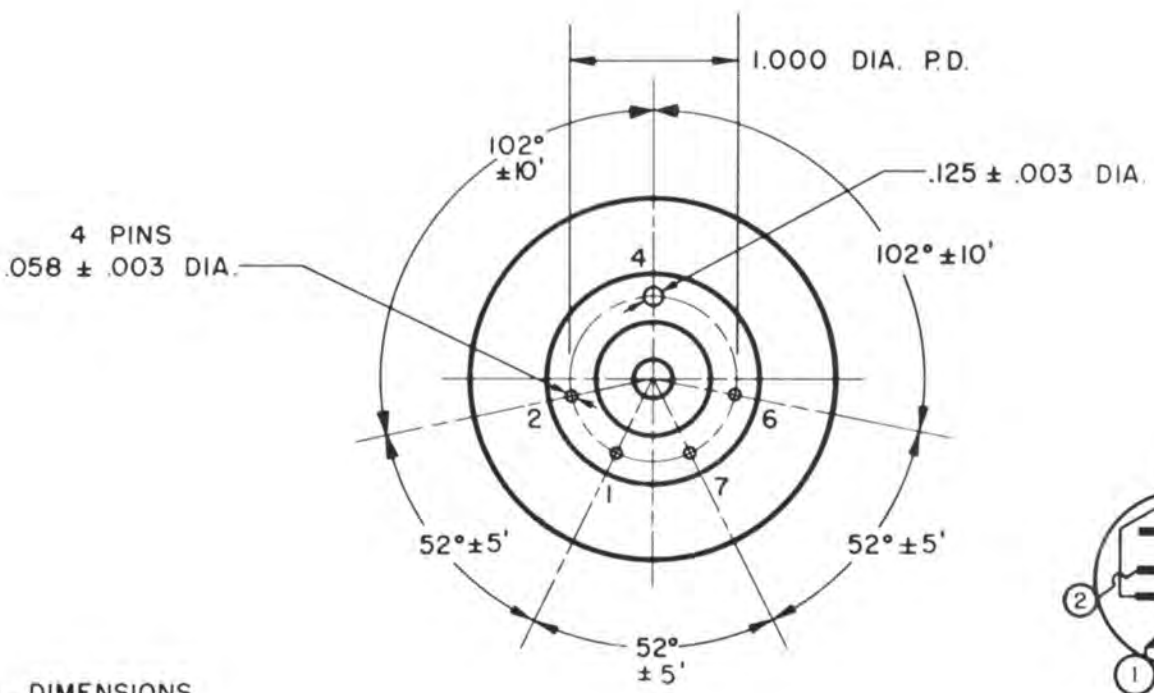
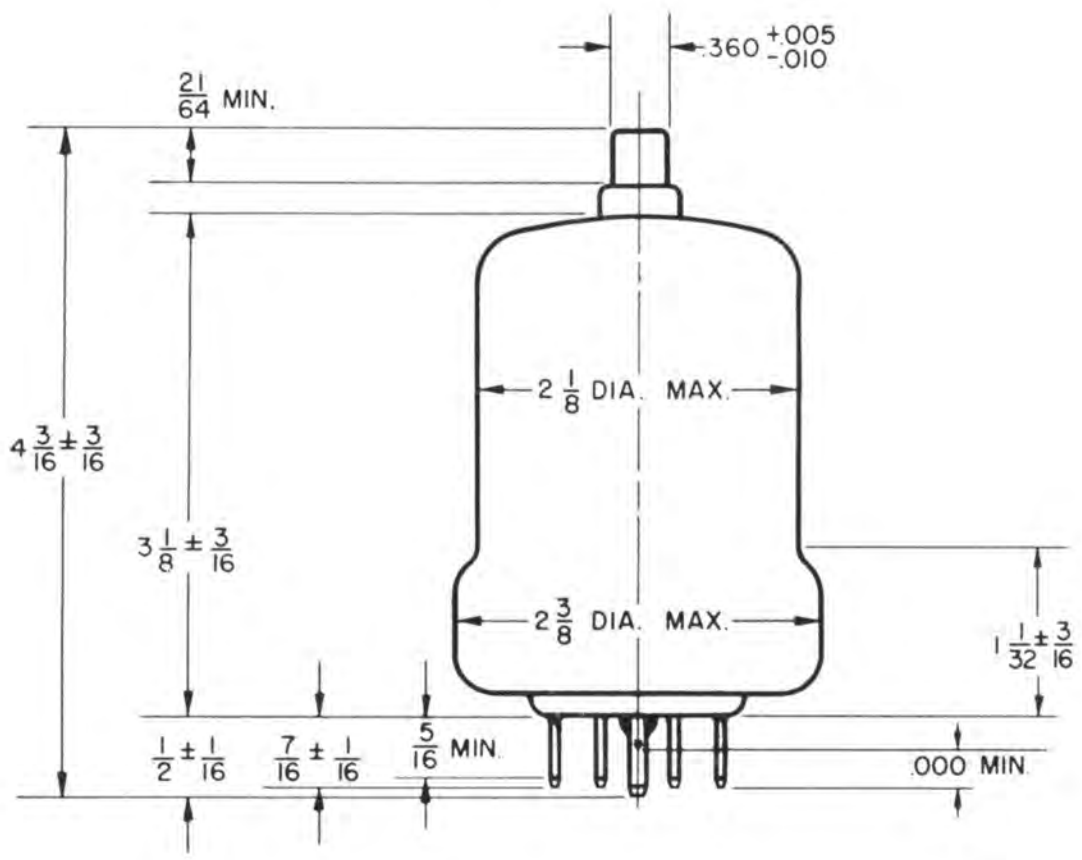

ALL DIMENSIONS
IN INCHES

BOTTOM VIEW

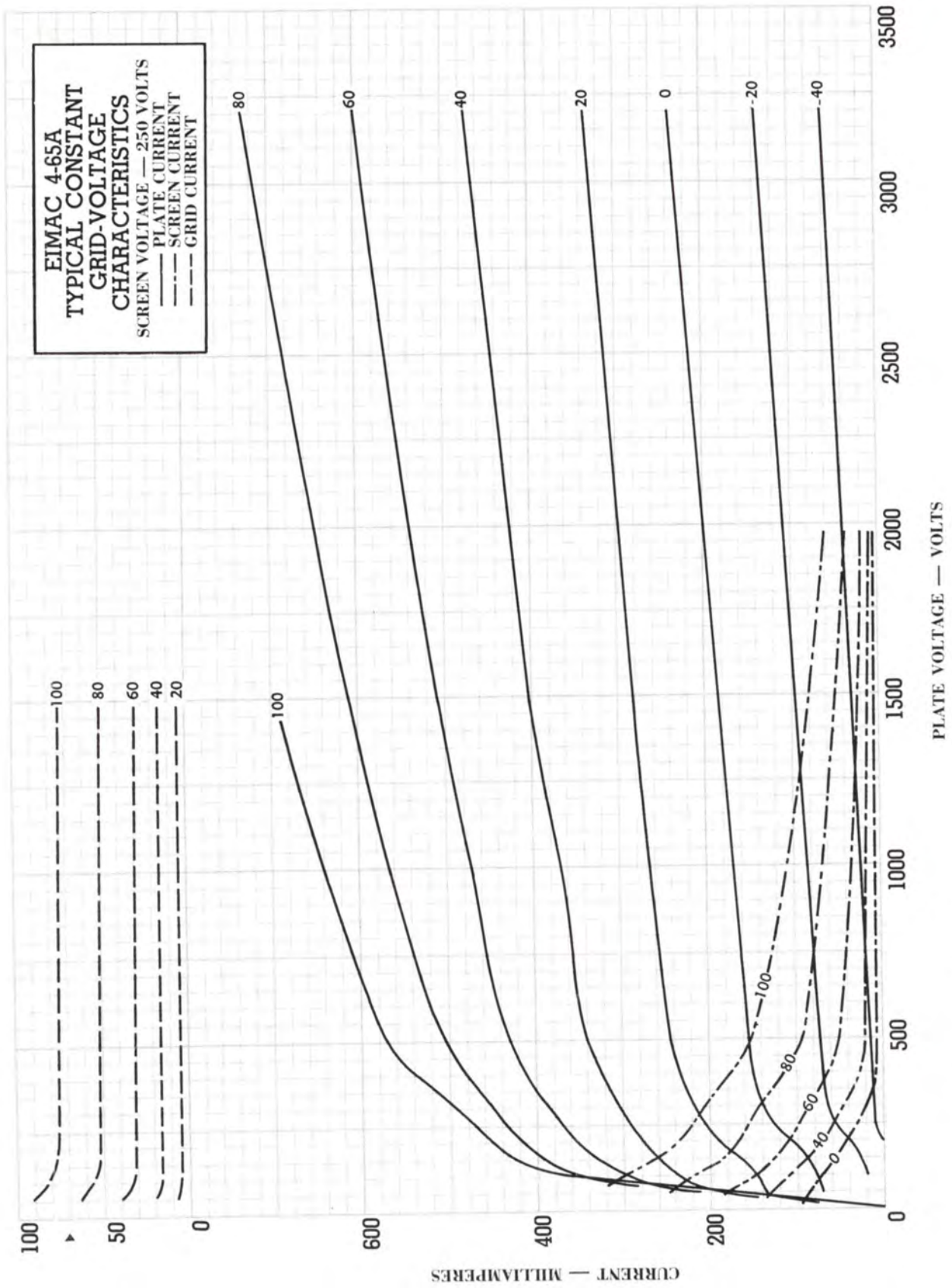



4-65A

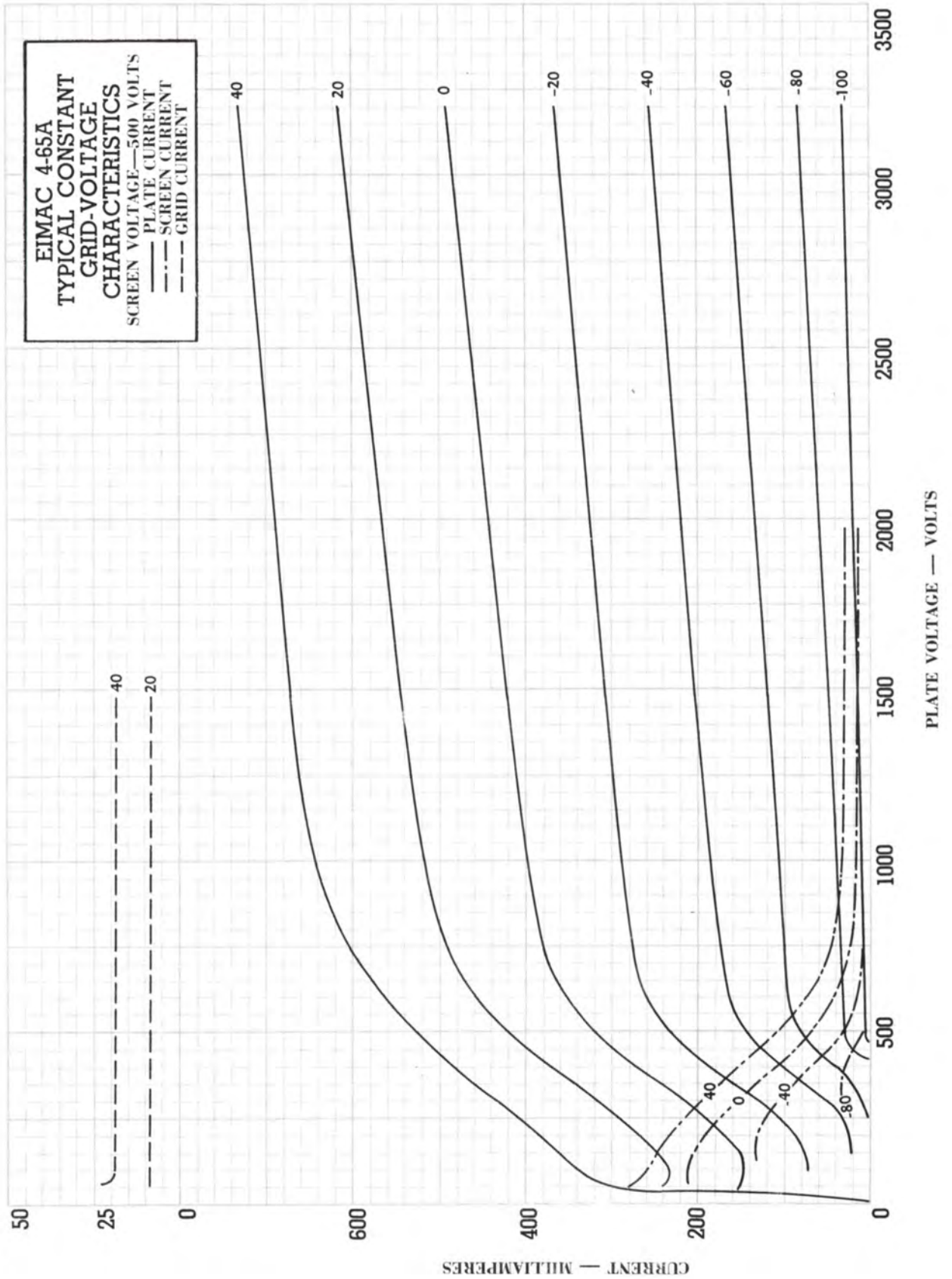

EIMAC 4-65A

TYPICAL

CONSTANT CURRENT CHARACTERISTICS

SCREEN VOLTAGE — 250 VOLTS

- PLATE CURRENT AMPERES
- · - · - SCREEN CURRENT AMPERES
- - - GRID CURRENT AMPERES

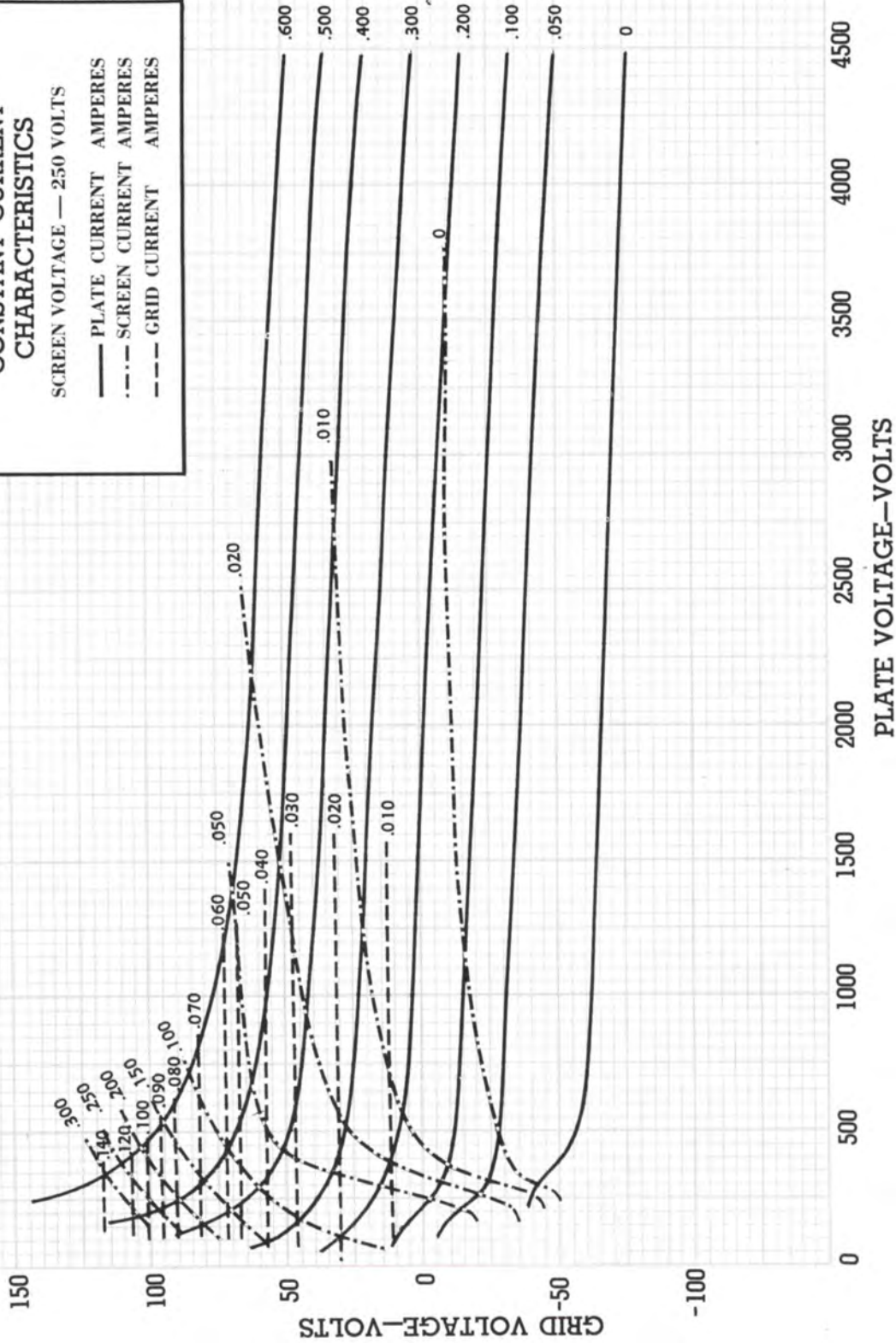

November 2, 1961

SERVICE MEMORANDUM NO. 11261

Subject: Test Meter
Type 315B/316B Transmitter

*Change made
in 316-B
12/28/61*

In Service Memorandum No. 102361 there are a few errors in listing the parts required for the test meter modification. A corrected parts list appears below:

315B/316B Transmitter Modifications

<u>Symbol</u>	<u>Previous Type</u>	<u>New Type</u>
✓ M203	Marion Series 55, 200 ua, 0-120 % scale	Simpson Model 29 200 ua, 1000 ohms/v. 0-20 MA scale
R210 <i>V207 -807</i>	2.7 ohm, 2 w, <u>±</u> 10%	1 ohm, <u>±</u> %, IRC ✓ Type WW4
<i>RF</i> ✓ R219 <i>V204 DRIVE 4-65A</i>	15 ohm, 2 w., <u>±</u> 10%	10 ohm, 2 w, <u>±</u> 5% —
✓ R220 <i>V204 CAT HODS 4-65A</i>	Same as R210 - 2.7Ω	Same as R210
R250 <i>V206</i>	Same as R219	Same as R219 — 10Ω
R259	Same as R210	Same as R210
Test Meter Switch	19031-2	19031-83
Nameplate		

Note: Remove R241, and connect directly to M203.

Orders for these modification parts which have been received prior to today's date will be corrected to include parts per the revised list. Pricing remains the same.

R. P. Buckner

Distribution: Serial #1 through 49

RPB/eb1

October 23, 1961

SERVICE MEMORANDUM NO. 102361

Subject: Test Meter
Type 315B/316B Transmitter

It has seemed desirable to change the test meter circuitry in the Type 315B/316B transmitter, to enable meter readings to be made directly in milliamperes. Previous readings permitted approximate indications only and were in "Percent".

Transmitter Serial Numbers 50 and above include this change as a factory modification. Those transmitters with lower Serial Numbers, which are now in the field, may be modified to utilize the new arrangement, if desired. The following list gives the required component changes. No wiring revisions are required.

30XT Oscillator Modifications

<u>Symbol</u>	<u>Previous Type</u>	<u>New Type</u>
✓R2	47 ohm, 1 w, $\pm 10\%$	RC 32 GF 390K 39 ohm, 1 w, $\pm 10\%$
✓R3	2 ohm, 1 w, I R C PT-4	10 ohm, 1 w, $\pm 5\%$ RC 32 GF 100 J

315B/316B Transmitter Modifications

<u>Symbol</u>	<u>Previous Type</u>	<u>New Type</u>
M203	Marion Series 55 200 ua, 0-120 % scale	Simpson Model 29 <i>211-32217</i> 200 ua, 1000 ohms/v. 0-20 mA scale
✓R210	2.7 ohm, 2w, $\pm 10\%$	1 ohm, $\pm 1\%$, 1 KC Type WW4
R219	15 ohm, 2 w., $\pm 10\%$	10 ohm RW. $\pm 5\%$ Same as R210
R250	Same as R219	Same as R219
R259	Same as R210	Same as R210
Test Meter Switch	19031-2	19031-2 ⁸³ (revised)
Nameplate		

Note: Remove R241, and connect directly to M203.

The above listed parts required for the modification are available from Continental Electronics at \$33.30, F.O.B. Dallas.

R. P. Buckner

Distribution: Serial #1 through 49

RPB/eb1

November 2, 1961

SERVICE MEMORANDUM NO. 11261

Subject: Test Meter
Type 315B/316B Transmitter

In Service Memorandum No. 102361 there are a few errors in listing the parts required for the test meter modification. A corrected parts list appears below:

315B/316B Transmitter Modifications

<u>Symbol</u>	<u>Previous Type</u>	<u>New Type</u>
M203	Marion Series 55, 200 ua, 0-120 % scale	Simpson Model 29 200 ua, 1000 ohms/v. 0-20 MA scale
R210	2.7 ohm, 2 w, $\pm 10\%$	1 ohm, $\pm 1\%$, IRC Type WW4
R219	15 ohm, 2 w., $\pm 10\%$	10 ohm, 2 w, $\pm 5\%$
R220	Same as R210	Same as R210
R250	Same as R219	Same as R219
R259	Same as R210	Same as R210
Test Meter Switch	19031-2	19031-83
Nameplate		

Note: Remove R241, and connect
directly to M203.

Orders for these modification parts which have been received prior to today's date will be corrected to include parts per the revised list. Pricing remains the same.

R. P. Buckner

Distribution: Serial #1 through 49

RPB/eb1



NOTES

KNT HAS LOST 2 OF THEIR
56 Ω 2 WATT RESISTORS IN GRID
OF THE 4CX5000A FINALS - LOCATED
IN CHAMBER JUST BELOW TUBES

March 21, 1960

SERVICE MEMORANDUM NO. 32160

Subject: Blower Holdover Relay Connections
Commercial Transmitting Equipment

In the Type 315B, 316B, 317B and 416B transmitters, it has been noted that imperfect blower holdover action sometimes obtains, due to contact bounce in the Cramer time delay relay, K112. It is suggested that a simple wiring change be made in existing transmitters to correct this problem.

Attached are two copies of schematic No. 19001-E, revised to show this circuit as corrected. These drawings should replace the older editions now in the transmitter instruction manuals.

Remove all AC line voltage from the transmitter and make the following wiring change (refer to transmitter intra-unit wiring list):

1. Determine that wire #60 connects between K101-5 and K104-1.
2. Determine that wire #14 connects between K104-10 and K112-7.
3. Remove wire #60 at K104-1, splice on additional length, and reconnect at K104-10. Note that the new connection is made at K104-10 together with wire #14, which was previously at that location.

Note that several other corrections have been made on schematic 19001-E, to conform to existing wiring. (These changes represent drawing corrections, not unit modifications.)

Also attached is a revised copy of Intra-wiring list, I-1, with error correction as shown.

RPB/tm
Enclosures

Distribution:

- 315B/316B, Serial Nos. 1 to 6 and 8 to 14 (schematic rev. I)
- 315B/316B, Serial Nos. 7 and 15 thru 23 (schematic rev. F)
- 315B/316B, Serial Nos. 24 and above (schematic rev. G)
- 317B, Serial Nos. 1 thru 4 (schematic rev. I)
- 416B, Serial No. 1 (schematic rev. A)

Completed
1/22/63

April 16, 1962

SERVICE MEMORANDUM NO. 041662
(315B/316B Memo No. 15)

Subject: Audio Squelch Relay
Type 315B/316B/317B Transmitters

For certain purposes, such as pattern changing and Conelrad alerting, it is required to remove transmitter rf excitation for brief periods. During these periods, under some conditions of continuing high modulation, tripping of the low voltage breaker, CB105 may occur.

To prevent this action, an additional relay designated "Audio Squelch" has been added in 315B/316B Transmitters, Serial Numbers 53 and above, and in 317B Transmitters, Serial Numbers 10, 12 and above. It is recommended that the audio squelch relay, K215, be added to all existing transmitters.

For the required circuit action, a new contact is added to excitation release relay K201, and is used to operate K215. The attached sheet lists the modification procedure and additional parts required. These parts may be procured locally or from the Continental factory, if desired.

Attached are two copies of drawing 19002-E, revision B, for 315B/316B transmitters, (or drawing 25781-E, revision B, for 317B transmitters, Serial Numbers 10, 12 and above) which show the change.

RPB/eb1

R. P. BUCKNER

Attachments

Distribution: 315B/316B, Serial Numbers 52 and below.
317B, Serial Numbers 1 - 9, and 11.
CBS, N. Y.
ABC, N. Y.

Modification Parts:

Parts required to change K201 from Single to Double Pole action:

<u>Item</u>	<u>Manufacturer</u>	<u>Part Number</u>
✓ Two Slotted Nuts	Struthers-Dunn	131
✓ One Movable Contact	Struthers-Dunn	20753
✓ One Compression Spring	Struthers-Dunn	2887
✓ One Cup Washer	Struthers-Dunn	21946
✓ Two Flat Hex Nuts	Struthers-Dunn	434
✓ One Stationary Contact	Struthers-Dunn	16332
✓ Squelch Relay - K 215	Ohmite	Type DOSX-59T
✓ Inter-connecting Terminal Board TB207	General Products	Type 5-441
✓ Inter-connecting Terminal Board TB208	General Products	Type 2-441

Procedure:

1. Mount K215 and TB207 on a 3" x 4" aluminum plate. This plate will be mounted inside the door frame of the amplifier cabinet, above the front edge of the modulator shelf. Position TB207 at the bottom edge of the plate.
2. Mount TB208 on the end lip of the RF shelf just to the right of the door frame.
3. Before mounting the plate containing K215 and TB207 in the transmitter, interconnecting wiring should be installed as follows:

- ✓ K215-2 (one side of coil) to TB207-2
- ✓ K215-1 (other side of coil) to K215-6 and to Chassis Ground.
- ✓ K215-4 to TB207-3
- ✓ K215-5 to TB207-4
- ✓ K215-7 to TB207-5

4. Add parts to K201 to produce 2 pole normally-open action.
5. In later production the numbering on K201 has been changed to conform to standard Relay numbering procedure. Terminals 1 and 2 are coil terminals. Refer to Drawing #19002-E, revision B, (or #25781-E, revision B), for new terminal numbering, as described below. To connect K201 per revised circuit, remove all connections at K201 and install as follows:
 - ✓ Connect wire from S202-A to K201-5
 - ✓ Connect wire from Junction of R206 and R207 to K201-6
 - ✓ Connect wire from TB203-4 to K201-1
 - ✓ Connect wire from TB203-5 to K201-2

Procedure (Continued)

6. Other interconnections are made as follows:

- * Connect K201-3 to TB208-1
- | Connect TB208-1 to TB207-1
- + Connect TB207-1 to Magniphase TB1-3 (if used)
- + Connect TB207-2 to Magniphase TB1-4 (if used)

Note: If Magniphase not used, install jumper connection TB207-1 to -2.

- * Connect TB207-3 to R299-~~4~~ 3
- * Connect TB207-4 to R299-~~3~~ 4
- * Connect TB207-5 to junction at R245 and C238.



RPB/eb1

Continental Electronics

MANUFACTURING COMPANY

4212 SOUTH BUCKNER BLVD.

DALLAS 10, TEXAS

ISSUE:

April 26, 1957

SPECIFICATION

No. 10686

FILAMENT TRANSFORMER

Application:

Filament supply for a single Eimac 4X5000A tube. 7.5 volts at 75 amperes.

Primary:

230/208 volts 50 or 60 cycle with $\pm 5\%$ and $\pm 10\%$ taps

Insulation: 2500 volts RMS test to core

Secondary:

7.7 volts at 75 amperes

Center-tap to handle 10 amps.

Insulation: 7500 volts RMS test to core and to primary.

Temperature Rise:

Not more than 40°C above a 55°C ambient for full load CCS service.

Construction:

Dry type fully enclosed with terminals on top OR open Electroseal.

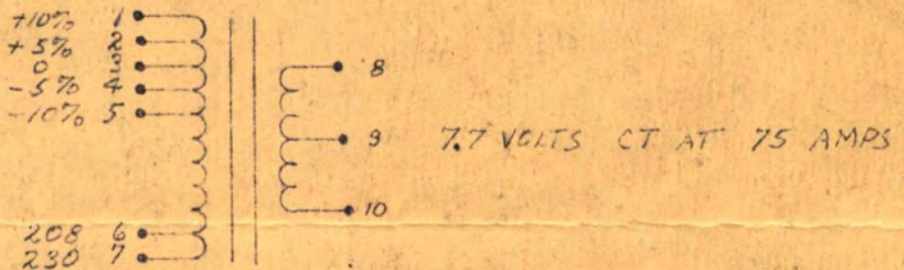

RECEIVED

FEB 24 1957

KCBS ENG. DEPT.

OUTLINE: PLEASE SUPPLY OUTLINE DRAWING SHOWING DIMENSIONS, MOUNTING, DETAILS, WEIGHT, ETC.
GUARANTEE: THE SUPPLIER SHALL GUARANTEE THE ITEM TO MEET THIS SPECIFICATION AND TO BE FREE FROM LATENT DEFECTS IN DESIGN AND CONSTRUCTION AND FROM FAULTY WORKMANSHIP AND MATERIALS.

WCAU RADIO

Office Communication

to: Jack Jones

October 27, 1965

from: Charles Miller

In reply to your request for information regarding difficulties with the Continental 316B transmitter since installation in 1960, failures have been entirely due to faulty parts. Items which were replaced or modified are as follows:

Item 263 - 65A audio driver plate resistor - failed due to insufficient power rating of resistor.

Item 215 - R.F. chassis dropping resistor - failed for same reason.

Item C-215 - PA grid capacitor - part of grid tuning network, end plate became unsoldered. Detuning exploded grid resistors Item R-232 on 1 tube.

Item R-229 - PA plate parasitic resistor network exploded, and blew out grid resistor R-232 on 1 tube

Item R232 - PA grid resistors opened 2 additional times not associated with other problems. These were replaced with a network of four resistors in parallel increasing the power rating from 2 to 8 watts.

All failures but one were discovered during test periods. The one case involving one of R-232 PA grid resistors did not cause dead air but resulted in 30% carrier shift and distortion until 50KW could be restored.

Transmitter is tested twice each week - Monday maintenance calibration air test, and Wednesday dummy load test.

CONTINENTAL ELECTRONICS MANUFACTURING COMPANY

December 14, 1959

SERVICE MEMORANDUM NO. 121459

Subject: Wiring Lists -- Type 315B/316B Transmitter

Several requests have been received for detailed wiring information on the Type 315B/316B Transmitter. Attached are two copies of our wiring lists, which will prove helpful in trouble-shooting.

Please note that, although the rectifier unit lists are for transmitter Serial Nos. 7, 15 and above, they will also serve as a useful guide for the lower serial numbers. Except for the power cutback circuitry, wiring differences are minor.

RPB/tm

INTRA-UNIT WIRING LIST

UNIT- 1

Date _____

File # I

Page 1

of 5

Title: Rectifier Unit -- Ser. 7, 15, & Above
Type 315B/316B Transmitter

Schematic # 19001-E

EPL # 7428

Assembly# _____

FO- _____

Wire #	Size	From	To	Route
1	14	CB2-2	K4-3	
2	14	CB2-4	K4-5	
3	14	CB2-6	K4-7	
4	14	K4-4	TB7-1	
5	14	K4-4	TB1-3	
6	14	K4-6	TB7-2	
7	14	K4-6	TB1-2	
8	14	K4-8	TB7-3	
9	14	K4-8	TB1-1	
10	16	CB2-2	S5.2-3	
11	16	CB2-4	S5.2-2	
12	16	CB2-6	S5.1-2	
13	16	K4-9	K1-6	
14	16	K4-10	K12-7	
15	12	CB3-2	K5-3	
16	12	CB3-4	K5-5	
17	12	CB3-4	CB4-5	
18	16	CB4-2	K5-7	
19	16	CB4-4	K5-9	
20	12	CB4-6	K5-11	
21	16	CB4-8	TB3-4	
22	16	CB4-7	E1-Gnd	
23	12	K5-4	TB1-6	
24	16	K5-4	DS4-1	
25	12	K5-6	TB1-7	
26	16	K5-6	DS4-2	
27	16	K5-8	TB1-8	
28	16	K5-10	TB3-2	
29	12	K5-12	TB1-9	
30	12	TB1-20	TB3-1	
31	14	CB5-2	K6-3	
32	14	CB5-4	K6-5	
33	16	CB5-6	C4-2	
34	16	CB5-5	E1-Gnd	
35	14	K6-4	T2-2	
36	16	K6-4	DS5-1	
37	14	K6-6	T2-1	
38	16	K6-6	DS5-2	
39	16	K6-7	TB2-4	
40	16	K6-8	DS3-1	
41	12	CB1-1	TB1-23	
42	12	CB1-3	TB1-24	

INTRA-UNIT WIRING LIST

UNIT- 1

Date _____

File # I

Page 2

of 5

Title: Rectifier Unit -- Ser. 7, 15, & Above
Type 315B/316B Transmitter

*Indicates wiring as was in Ser. 23 and below

Schematic # 19001-E EPL # 7428 Assembly# _____ FO- _____

Wire #	Size	From	To	Route
43	16	CB1-4	TB4-2	
44	16	K1-2	K4-2	
45	16	K4-2	K5-2	
46	16	CB1-4	K12-5	
47	16	CB4-3	CB1-2	
48	16	TB4-2	TB3-1	
49	16	TB1-20	K2-2	
50	16	K13-2	M3-2	
51	16	M3-2	DS3-2	
52	16	CB1-2	K1-8	
53	16	CB1-2	TB2-2	
54	16	TB2-2	TB2-8	
55	16	TB2-8	S3-2	
56	16	K1-1	S1-2	
57	16	K1-1	K3-6	
58	16	K3-6	K2-11	
59	16	K2-11	S2-1	
60	16	K1-5	K4-1	
61	16	K4-1	K12-6	
62	16	K1-4	K12-1	
63	16	K5-2	DS1-2	
64	16	K5-1	DS1-1	
65	16	K5-1	TB1-5	
66	16	TB1-4	S7-1	
67	16	K6-2	DS2-2	
68	16	K6-2 (*K6-1)	K1-10	
69	16	K1-9 (*K6-2)	S8-2	
70	16	K13-7	TB1-10	
71	16	K6-1 (*K1-9)	E1-Gnd	
72	16	K2-1	DS3-1	
73	16	K2-2	DS3-2	
74	16	DS3-1	M3-1	
75	16	TB1-21	K2-9	
76	16	K2-9	K2-1	
77	16	K2-10	TB1-22	
78	16	TB1-11	TB3-3	
79	16	TB1-12	M2-(/)	
80	16	TB1-13	TB4-9	
81	16	TB1-14	TB4-10	
82	16	TB1-15	TB4-11	
83	16	TB1-19	TB4-12	
84	16	TB1-19	CR3-1	

INTRA-UNIT WIRING LIST

UNIT- 1

Date _____

File # I

Page 3

of 5

Title: Rectifier Unit -- Ser. 7, 15, & Above
Type 315B/316B Transmitter

*Indicates wiring as
 was in Ser. 23 and
 below.

Schematic # 19001-E

EPL # 7428

Assembly# _____

FO- _____

Wire #	Size	From	To	Route
182	16	K6-1 (*K1-9)	DS2-1	
85	16 HV	E3	R3-2	
86	14 HV	E2	L5-2	
87	16	TB1-16	K3-5	
88	16 HV	E4	R2-1	
89	16	S1-1	TB2-1	
90	16	TB2-3	TB4-3	
91	16	TB2-5	TB4-4	
92	16	TB2-6	TB4-5	
93	16	TB2-7	TB4-6	
94	16	TB2-7	S3-1	
95	16	TB2-9	TB4-7	
96	16	TB4-8	E1-Gnd	
97	16	TB2-10	E1-Gnd	
98	16	TB2-11	M2-(-)	
99	16	R9-2	E1-Gnd	
100	16	TB2-12	R10-1	
101	16	R10-3 (*R10-2)	M4- (/)	
102	16	M4-(-)*	E1-Gnd	
103	14 HV	L5-1	CR3-2	
104	16	M1-1	S5-A	
105	16	M1-2	S5-B	
106	16	S8-1	K13-5	
107	16	TB1-5	R11-1	
108	16	K1-6	K1-8	
109	16	K1-3	K1-5	
110	16	K12-3	K12-1	
111	16	K12-5	K1-2	
112	16	K1-7	S7-2	
113	16	CB1-4	K3-1	
114	16	K3-1	K3-3	
115	16	TB8-3	K2-12	
116	16	TB8-3	S4.1-3 (*S4.1-2)	
117	16	S4.1-3 (*S4.1-2)	S4.2-1	
118	16	TB8-1	S2-2	
119	16	TB8-1	TB4-1	
120	16	TB8-1	TB8-2	
121	16	TB4-13	S4.2-4	
122	16	TB8-2	S4.1-2 (*S4.1-3)	
123	16	TB8-4	K3-2	
124	16	TB8-4	S4.1-1	
125	16	TB8-5	K3-4	

Date _____

INTRA-UNIT WIRING LIST

UNIT- 1File # IPage 4of 5

Title: Rectifier Unit -- Ser. 7, 15, & Above
Type 315B/316B Transmitter

*Indicates wiring as
 was in Ser. 23 and
 below.

Schematic # 19001-EEPL # 7428

Assembly# _____

FO- _____

Wire #	Size	From	To	Route
126	16	TB8-5	S4.2-3(*S4.2-2)	
127	16	S4.1-4	S4.2-2(*S4.2-3)	
128	16 HV	C4-1	L4-1	
129	16 HV	C4-1	R2-1	
130	16 HV	L6-2	C8-2	
131	16 HV	L6-2	R3-2	
132		C4-2	C3-2	
133	16	C3-2	CR2.2-(-)	
134	16	C3-2	R2-2	
135	16	R2-2	R3-1	
136	16	R3-1	C7-1	
137		C7-1	C8-1	
138	16 HV	T2-4(*T2-6)	CR2.2-(/)	
139	16 HV	T2-5(*T2-7)	L3-2	
140	16 HV	T2-6(*T2-8)	CR2.2-(/)	
141	16 HV	GR2.1-(/)	L2-1	
142	16 HV	L3-1	C3-1	
143	16 HV	C3-1	L4-2	
144	16 HV	L2-2	L6-1	
145	16 HV	L6-1	C7-2	
		R1-1 & 2	CB5-5 & 6	
		C5-1 & 2	M4-(/) & (-)	
		C6-1 & 2	M2-(/) & (-)	
146	16	K3-8	TB8-6	
147	16	K3-9	TB8-7	
148	16	K3-10	TB8-8	
149	16	TB1-20	DS6-2	
150	Bus	DS6-2	DS7-2	
151	16	DS6-1	K3-5	
152	16	DS7-1	K3-7	
153	14 HV	CR3-3	T3.1-4	
154	14 HV	T3.1-4	**K15-10 TP3	
155	14 HV	T3.1-7	**K15-3 TP1 (Tape)	
156	14 HV	T3.1-9	**K15-5 TP1	
157	14 HV	CR3-4	T3.3-4	
158	14 HV	T3.3-4	**K15-7 TP2	
159	14 HV	T3.3-7	**K15-9 TP3 (Tape)	
160	14 HV	T3.3-9	**K15-11 TP3	
161	14 HV	CR3-5	T3.2-4	
162	14 HV	T3.2-4	**K15-4 TP1	
163	14 HV	T3.2-7	**K15-6 TP2 (Tape)	
164	14 HV	T3.2-9	**K15-8 TP2	

**Connections made for power cutback only, when K15 is used. Alternate connections shown in "Route" column. "Tape" indicates wire is taped up near, but not connected

INTRA-UNIT WIRING LIST

UNIT- 1

Date _____

File # I

Page 5

of 5

Title: Rectifier Unit -- Ser. 7, 15, & Above
Type 316B/316B Transmitter

*Indicates wiring as
 was in Ser. 23 and
 below.

Schematic # 19001-E

EPL # 7428

Assembly# _____

FO- _____

Wire #	Size	From	To	Route
165	4	TB5-1	K2-3 (*K2-7)	
166	4	TB5-2	K2-5	
167	4	TB5-3	K2-7 (*K2-3)	
168	4	TB5-1	CB2-1	
169	10	CB2-1	CB3-1	
170	10	CB3-1	CB4-1	
171	10	CB4-1	CB5-1	
172	4	TB5-2	CB2-3	
173	10	CB2-3	CB3-3	
174	10	CB3-3	CB5-3	
175	4	TB5-3	CB2-5	
176	4	K2-8	T3.3-3	
177	4	T3.1-1	T3.3-3	
178	4	K2-6	T3.3-1	
179	4	T3.3-1	T3.2-3	
180	4	K2-4	T3.2-1	
181	4	T3.2-1	T3.1-3	
	10	TB1-24	E1-Gnd	
	16	TB2-1	TB2-2	
	16	TB2-3	TB2-4	
		R11-2	K13-3	
		R9-1	M2-(-)	
	16	R10-2	M4-(-)	
	16	S5.1-2	S5.1-4	
	16	S5.1-3	S5.2-2	
	16	S5.2-4	S5.2-3	
Additional for 50 KW Driver only:				
Delete the following:				
40	16	K6-8	DS3-1	
68	16	K1-10	K6-2	
Add the following:				
		K6-8	TB6-5	
		K2-1	TB6-6	
		K1-10	TB6-3	
		K6-2	TB6-4	
		TB1-5	TB6-2	
		S1-2	TB6-1	
		TB4-1	TB6-7	
		TB4-15	TB6-8	

INTRA-UNIT WIRING LIST

UNIT- 1

Date _____

File # III

Page 1

of 2

Title: Relay Panel, Rectifier Unit -- Ser. 7, 15, & Above
Type 315B/316B Transmitter

Schematic # 19001-E EPL # 7428 Assembly# _____ FO- _____

Wire #	Size	From	To	Route
1	16	TB4-1	K11-5	
2	16	K8-5	K9-5	
3	16	K9-5	K10-5	
4	16	K10-5	K11-5	
5	16	TB4-2	K7-2	
6	16	K7-2	K7-4	
7	16	TB4-3	K7-6	
8	16	TB4-4	K7-8	
9	16	TB4-5	K7-7	
10	16	TB4-6	K7-3	
11	16	TB4-7	R8-2	
12	Bus	R8-2	R4-2	
13	Bus	R4-2	R5-2	
14	Bus	R5-2	R6-2	
15	16	K8-2	R4-2	
16	16	R4-2	Slider	
17	16	R5-2	K9-2	
18	16	R5-2	Slider	
19	16	R6-2	K10-2	
20	16	R6-2	Slider	
21	16	R8-2	Slider	
22	16	TB4-8	R8-1	
23	16	R8-1	R7-2	
24	16	R7-2	K11-2	
25	16	R7-2	Slider	
26	16	TB4-9	R4-1	
27	16	R4-1	K8-1	
28	16	TB4-10	R5-1	
29	16	R5-1	K9-1	
30	16	TB4-11	R6-1	
31	16	R6-1	K10-1	
32	16	TB4-12	R7-1	
33	16	R7-1	K11-1	
34	16	TB4-13	K8-3	
35	16	K7-5	K11-4	
36	16	K7-1	K11-6	
37	16	K11-6	K8-6	
38	16	K8-6	K9-6	
39	16	K9-6	K10-6	
40	16	K10-4	K11-3	
41	16	K8-4	K9-3	
42	16	K9-4	K10-3	

INTRA-UNIT WIRING LIST

UNIT- 1

Date _____

File # III

Page 2

of 2

Title: Relay Panel, Rectifier Unit -- Ser. 7, 15, & Above
Type 315B/316B Transmitter

Schematic # 19001-E EPL # 7428 Assembly# _____ FO- _____

Wire #	Size	From	To	Route
NOTE: The following connections not used when supplied as a 5 KW Transmitter:				
3	16	K9-5	K10-5	
4	16	K10-5	K11-5	
14	Bus	R5-2	R6-2	
19	16	R6-2	K10-2	
20	16	R6-2	Slider	
30	16	TB4-11	R6-1	
31	16	R6-1	K10-1	
39	16	K9-6	K10-6	
40	16	K10-4	K11-3	
42	16	K9-4	K10-3	
		Add		
	16	K9-4	K11-3	
	16	K9-5	K11-5	
Additional for 50 KW Driver only:				
	16	K7-1	TB4-15	

INTRA-UNIT WIRING LIST

UNIT- 2

Date _____

File # IV

Page 1

of 3

Title: Amplifier Unit
Type 315B/316B Transmitter

*Indicates wiring as
 was in Ser. 23 and
 below.

Schematic # 19002E EPL # 7429 Assembly# _____ FO- _____

Wire #	Size	From	To	Route
1	14 (*16)	TB1-1	TB5-1	
2	14 (*16)	TB1-2	TB5-2	
3	14 (*16)	TB1-3	TB5-3	
4	16	TB1-4	S4-2	
5	16	TB1-5	S4-1	
6	12	TB1-6	T1-2	
7	12	TB1-7	T1-7	
8	16	TB1-8	TB3-1	
9	16	TB1-8	TB4-1	
10	12	TB1-9	TB3-2	
11	12	TB1-9	TB4-2	
12	16	TB1-10	S3-1	
13	16	TB1-11	S3-2	
14	16	TB1-11	TB3-3	
15	16	TB1-12	R96-1	
16	16	TB1-13	R38-2	
17	16	TB1-14	R39-2	
18	16	TB1-15	R40-2	
19	16	TB1-16	TB4-4	
20	16	TB1-17	TB3-11	
21	16	TB1-18	R24-3	
22	16	TB1-19	C50.1-2	
23	16	TB1-20	K2-2	
24	16	TB1-21	K3-1	
25	16	TB1-22	RT1-2	
26	16	TB1-23	TB3-4	
27	16	TB1-20	TB3-5	
28	20	S1-A1	TB3-6	
29	20	S1-A2	TB3-7	
30	20	S1-A3	TB3-3	
31	20	S1-A4	TB3-9	
32	20	S1-A5	R28-2	
33	20	S1-A6	R38-1	
34	20	S1-A7	R39-1	
35	20	S1-A8	R40-1	
36	20	S1-A9	TB4-5	
37	20	S1-A10	TB4-6	
38	20	S1-B1	E1-Gnd	
39	20	S1-B3	TB3-8	
40	20	S1-B5	R28-1	
41	20	S1-B6	R38-2	
42	20	S1-B7	R39-2	

INTRA-UNIT WIRING LIST

UNIT- 2

Date _____

File # IV

Page 2

of 3

Title: Amplifier Unit
315B/316B Transmitter

*Indicates wiring as was in Ser. 23 and below.

Schematic # 19002-E EPL # 7429 Assembly# _____ FO- _____

Wire #	Size	From	To	Route
43	20	S1-B8	R40-2	
44	16	RT1-1	K2-1	
45	16	RT1-2	K2-4	
46	16	K2-2	K3-2	
47	20 T. P. Sh	TB2-1 & 2	TB4-7 & 8	
48	RG59	TB2-4	TB3-13	
49	RG59	TB2-5	L19	
50	16	R38-1	T1-4	
51	16	R39-1	T2-4	
52	16	R40-1	T3-4	
53	16 HV	M1- (/)	E3	
54	16 HV	M1- (-)	E7	
55	14 HV	M2- (/)	E5	
56	14 HV	K3-3	R95-1	
57	14 HV	R95-1	E2	
58	14 HV	M2- (-)	L14-1	
59	14 HV	L14-1	C30	
60	12	T1-7	T2-7	
61	12	T2-7	T3-7	
62	12	T1-2	T2-2	
63	12	T2-2	T3-2	
64	16	TB3-3	R28-2	
65	16	TB2-3	TB2-6	
66	16	TB2-6	E1-Gnd	
67	16 HV	E3	C17-1	
68	16 HV	E4	C42-1	
69	16 HV	E4	R15-1	
70	16 HV	R15-2	C12-1	
71	14 HV	E5	K3-4	
72	RG59	TB4-10	L15-3	
73	16	R24-1	TB3-12	
74	16	R24-2	R25-1	
75	16	TB3-5	TB4-3	
76	16	R24-3	TB3-11	
77	16	R25-2	E1-Gnd	
78	16	R14-1	TB3-10	
79	16	R27-1	L9	
80	16	K2-1	K2-3	
81	16	R94-2	E1-Gnd	
82	20	R41-1(*M3 /)	S1-A	
83	20	M3 (-)	S1-B	
84	14 HV	K2-5	R95-1	

INTRA-UNIT WIRING LIST

UNIT- 2

Date _____

File # IV

Page 3

of 3

Title: Amplifier Unit
315B/316B Transmitter

Schematic # 19002-E EPL # 7429 Assembly# _____ FO- _____

Wire #	Size	From	To	Route
85	14 HV	K2-6	R95-2	
86	16 HV	E3	E8	
87	14 HV	K3-3	R98-2	
88	16	R15-2	R14-2	
89	16	R27-2	R28-1	
90	RG59	TB2-7	R31-1	
91	16	TB1-23	TB1-21	
	14 HV	R98-2	R90-1	
	Bus	R96-2	R98-1	
		C35-2	Gnd	
		R15-1	C35-1	
		C34 across	M2	
		C49 across	M1	
		C36 across	M3	
		R41-2	M3- (f)	
Additional for 50 KW Driver only:				
Delete the following:				
91	16	TB1-21	TB1-23	:
72	RG58	TB4-10	L15-3	
Add the following:				
	16	TB6-1	K411-1	
	16	TB6-2	K411-2	
	Sh of coax	TB6-3	Gnd	
	RG58	TB6-4	K411-3	
	16	TB6-5	TB201-21	
	16	TB6-6	TB201-23	
	RG58	TB4-10	K411-4	
	RG58	L15-3	K411-5	
MAGNIPHASE Unit only:				
	16	Magni-TB1-7	50 KW Meter	
	16	" TB1-8	50 KW Meter	
	16	" TB1-8	TB4-11	
	RG58	" TB1-6	TB3-16	
	16	" TB1-1	TB201-4	

INTRA-UNIT WIRING LIST

UNIT- 2

Date _____

File # V

Page 1

of 2

Title: Driver Shelf, Amplifier Unit
Type 315B/316B Transmitter

Schematic # 19002-E EPL # 7429 Assembly# _____ FO- _____

Wire #	Size	From	To	Route
1	16	TB3-1	T4-1	
2	12	TB3-2	T4-4	
3	20	TB3-3	R19-2	
4	20	TB3-4	K1-3	
5	20	TB3-5	K1-4	
6	20	TB3-6	S2-C	
7	20	TB3-7	R10-1	
8	20	TB3-8	R19-1	
9	20	TB3-9	R20-1	
10	16	TB3-10	S2-B	
11	16	TB3-11	C13-1	
12	16	TB3-12	R23-2	
13	RG58)	TB3-13	C7-2	
14	Sh.)	TB3-14	Gnd	
15	20	XV3-4	R9-1	
16	20	R10-2	Gnd	
17	20	L5-2	R17-1	
18	20	R11-2	R12-1	
19	Bus	R20-2	R10-2	
20	Bus	C12-2	C17-2	
22	16 HV	C12-1	R23-1	
23	16 HV	L4-2	C12-1	
24	16 HV	C17-1	L7-1	
25	16 HV	L4-2	R12-2	
26	16 HV	L3-2	V3-C	
27	16 HV	L6-2	V4-C	
28	16)	T4-5	V4-1	
29	T.P.)	T4-7	V4-7	
30	20)	V4-1	V3-1	
31	T.P.)	V4-7	V3-5	
32	Bus	K1-2	R7-1	
33	Bus	C7-1	V3-4	
34	Bus	S2-A	K1-1	
35	Bus	L5-1	C9-2	
36	Bus	C9-1	L4-1	
37	Bus	R10-2	R13-2	
38	Bus	S2-A1	J1.1-8	
39	Bus	S2-A2	J1.2-8	
40	Bus	J1.1-1	J1.1-3	
41	Bus	J1.1-3	Gnd	
42	Bus	J1.2-1	J1.2-3	

INTRA-UNIT WIRING LIST

UNIT- 2

Date _____

File # V

Page 2

of 2

Title: Driver Shelf, Amplifier Unit

Type 315B/316B Transmitter

Schematic # 19002-E

EPL # 7429

Assembly# _____

FO- _____

Wire #	Size	From	To	Route
43	Bus	J1.2-3	Gnd	
44	20	S2-B1	J1.1-4	
45	20	S2-B2	J1.2-4	
46	20	S2-C1	J1.1-2	
47	20	S2-C2	J1.2-2	
48	20))	T4-5	J1-2-5	
49	T.P.)	T4-7	J1.2-6	
50	20	T4-6	R20-1	
51	20	J1.1-5	J1.2-5	
52	20	J1.1-6	J1.2-6	
53	Bus	T4-2	T4-3	
		V3-3	R6-1	
		R7-2	Gnd	
		L3-1	Feed thru	
		Feed thru	L4-1	
		V3-2	R11-1	
		L6-1	C14-1	
	Bus	C14-1	L8-1	
		C14-2	Gnd	
	Bus	C14-1-1	C14.2-1 -- If used	
		L7-2	L8-2	
	Bus	V4-2	V4-6	
		V4-2	R22-1	
		R22-2	C13-1	
		V4-4	R16-1	
		R16-2	C9-2	
	Bus	R17-2	R18-1	
	Bus	R18-2	R19-1	
	Bus	R13-1	R12-1	
		R11-2	C8-1	
		C8-2	Gnd	
		C13-2	Gnd	
		C10-2	Gnd	
		C11-2	Gnd	
		V4-1	C10-1	
		V4-7	C11-1	
	Bus	R9-2	R10-1	
		R6-2	R7-1	

INTRA-UNIT WIRING LIST

UNIT- 2

Date _____

File # VI

Page 1

of 4

Title: Modulator Shelf, Amplifier Unit

Type 315B/316B Transmitter

*Indicates wiring as was in Ser. 23 and below.

Schematic # 19002-E

EPL # 7429

Assembly# _____

FO- _____

Wire #	Size	From	To	Route
1	16	TB4-1	T6-1	
2	12	TB4-2	T6-4	
3	16	TB4-3	K4-2	
4	16	TB4-4	K4-1	
5	20	TB4-5	R49-2	
6	20	TB4-6	R59-2	
7	20 T.P.)	TB4-7	R99-1	
8	Sh.)	TB4-8	R99-2	
9	20	TB4-9	Gnd & Shield	
10	RG58	TB4-10	R43-2	
11				
12	16 HV	E-7	V8 Cap	Insulator on top of shel
13	16 HV	E-8	R86-1 (*R85-1)	
14	16 HV	R53-2	C42-1	
15	16 HV	C42-1	R89-1	
16	16	T5-1	T6-1	
17	12	T5-4	T6-4	
18	16	T5-5	V7-1	
19	16	T5-7	V7-7	
20	20	R60-1	C53-1	
21	16	V7-2	C43-1	
22	20	R62-1	V7-2	
23	20	R78-2	R79.1-1	
24	20	K4-4	R79.1-2	
25	16	R88-1	V10-2	
26	16	V6-2	C40-1	
27	16	R52-1	C40-1	
28	20	R49-1	C39-(/)	
29	16 HV	V10-Cap	R80-2	Not in cable form
30	16 HV	C41-1	V6-Cap	Not in cable form
31	20	V11-5	V10-4	Not in cable form
	16 Bus	C39-(/)	V6-4	
	16 Bus	R99-3	T7-1	
	16 Bus	R99-4	T7-6	
		R57-2	Gnd	
	16 Bus	C40-2	Gnd	
	16 Bus	V7-1	V6-1	
	16 Bus	V7-7	V6-5	
	16 Bus	V6-1	V10-1	
	16 Bus	V6-5	V10-5	
	16 Bus	V10-1	V9-2	
	16 Bus	V10-5	V9-7	

INTRA-UNIT WIRING LIST

UNIT- 2

Date _____

File # VI

Page 2

of 4

Title: Modulator Shelf, Amplifier Unit
Type 315B/316B Transmitter

*Indicates wiring as
 was in Ser. 23 and
 below.

Schematic # 19002-E

EPL # 7429

Assembly# _____

FO- _____

Wire #	Size	From	To	Route
	16 Bus	C42-2	Gnd	
	16 Bus	R57-1	V7-4	
	14 Bus	C44-2	R64-2	
	14 Bus	C45-2	R65-1	
	16 Bus	R80-1	R64-2	
	16 Bus	R81-1	R65-1	
	16 Bus	R70-2	T6-6	
	16 Bus	R78-1	R77-1	
	16 Bus	K4-3	Gnd	
	14 Bus	C44-1	V7-Cap	To 1" insulator - Top of shelf
	16 Bus	T6-5	V8.3-1	
	16 Bus	T6-7	V8.3-7	
	16 Bus	V8.3-1	V8.2-1	
	16 Bus	V8.3-7	V8.2-7	
	16 Bus	V8.2-1	V8.1-7	
	16 Bus	V8.2-7	V8.1-1	
	20 Bus	R48-1	T7-10	
	20 Bus	T7-G	Gnd	
	16 Bus	T6-6	R75-1	
	16 Bus	R75-2	L20-1	
	16 Bus	L20-2	Gnd	
	20 Bus	R78-3	V10-3	
	20 Bus	R45-3	C38-1	
	20 Bus	R45-2	Gnd	
	20 Bus	V9-3	V9-5	
		R70-2 (*C44-2)	C45-1	
	20 Bus	R63-1	C44-1	
	20	V10-1	R58-1	
	20	V10-5	R58-2	
	20	R58-3	C53-1	
	16 Bus	T6-2	T6-3	
	16	R275-1	L213	On tube shelf
	16 Bus	CR1-(-)	CR2-(-)	
	14 Bus	CR1-(-)	R58-3	
	20	CR1-(-)	T5-5	
	20	CR2-(-)	T5-7	
	16 Bus	T7-3	T7-4	
	16 Bus	T7-8	T7-9	
	14 HV	R63-2	R92	
		R35-2 (*C55-2)	C54-2	
		R56-1	R35-1 (*C54-2)	
	14 Bus	R55-1	C52-1	
		R75-2	C54-1	

INTRA-UNIT WIRING LIST

UNIT- 2

Date _____

File # VI

Page 3

of 4

Title: Modulator Shelf, Amplifier Unit
Type 315B/316B Transmitter

Schematic # 19002-E EPL # 7429 Assembly# _____ FO- _____

Wire #	Size	From	To	Route
	Bus	R55-1	C41-1	
		R43-1	R42-1	
		R42-2	R44-2	
		R44-2	V9-3 & 5	
		R44-1	R45-1	
		R45-1	C37-1	
		C37-2	Gnd	
		C52-2	R33-2	
		R32-1	R34-1	
		R34-2	C38-2	
		C38-2	T7-10	
		R48-1	R47-1	
		R47-2	T7-7	
		T7-7	R46-2	
		R46-1	V6-3	
	Bus	R49-2	R50-2	
		C53-2	Gnd	
	Bus	C39-(-)	Gnd	
		R48-2	Gnd	
		R51-1	R52-1	
		R51-2	Gnd	
	Bus	R52-2	R53-2	
	Bus	R53-1	R54-1	
	Bus	R54-2	R55-2	
	Bus	C41-2	R56-2	
	Bus	R56-1	R57-1	
	Bus	R77-2	R70-2	
	Bus	R70-1	R71-1	
	Bus	R71-2	R72-2	
	Bus	R72-1	R73-1	
	Bus	R73-1	C46-1	
	Bus	C46-2	R74-2	
	Bus	R74-1	R57-1	
		R57-1	V7-4	
	Bus	R79.2-1	R73-2	
	Bus	R73-2	R59-1	
	Bus	R59-1	R57-2	
	Bus	R57-2	R50-1	
		R61-1	C43-1	
		R61-2	C43-2	
		C43-2	Gnd	
	Bus	R62-2	R53-2	

Title: Modulator Shelf, Amplifier UNIT
Type 315B/316B Transmitter

Schematic # 19002-E EPL # 7429 Assembly# _____ FO- _____

Wire #	Size	From	To	Route
	Bus	R59-2	R60-2	
	Bus	T5-2	T5-3	
		R641	V8.1-4	
		R64-2	R66-2	
		R66-1	V8.2-4	
		R66-2	R68-2	
		R68-1	V8.3-4	
		R65-2	V8.1-2 & 6	
		R65-1	R67-1	
		R67-2	V8.2-2 & 6	
		R67-1	R69-1	
		R69-2	V8.3-2 & 6	
		V8.1 - V8.2 & V8.3 Caps - Paralleled		
		C47-1	V10-3	
		C47-2	Gnd	
		R79.1-2	R79.2.2	
		R76-1	L20-1	
		R76-2	L20-2	
	Bus	R88-2	R89-2	
		R87-1	V10-2	
		R87-2	V11-5	
		C48-1	V11-5	
		C48-2	V11-2	
		V11-2	Gnd	
	Bus	R85-2	R66-2	
	Bus	R81-1 thru R85-1 - Paralleled		
	Bus	R80-2 thru R84-2 - Paralleled		
		V9-8	Gnd	

1-3 PERFORMANCE DATA

10-21-59

1-5a

Type: 316B Ser. No.: 22 Freq.: 740 kc / 640 kc

Power Output: 10.6 KW at 740 KC
6.7 KW at 640 KC

Phant. Ant. 49 / j 16
48.5 / j 15

MOD. MON. Gen. Radio 1931-A

OSCILLATOR Hewlett-Packard 206A

DISTORTION MTR. Gen. Radio 1932-A

AUDIO PERCENT DISTORTION AT
FREQ. 25% 50% 85% 95%
640 740 640 740 640 740 640 740

FREQ.	25%		50%		85%		95%	
	640	740	640	740	640	740	640	740
50	.5	.55	.5	.55	2.4	.7	4.5	.8
100	.3	.27	3.5	.25	.4	.4	1.2	.5
400	.22	.2	.23	.15	.35	.35	.8	.45
1000	.3	.23	.25	.17	.45	.4	.8	.55
5000	.5	.3	.55	.18	.85	.75	1.8	.9
7500	.5	.5	.55	.6	2.9	1.2	4.0	1.5
10,000	.6	.55	.6	.7	4.5	1.6	5.0	1.9

PROGRAM LEVEL (DBM)
95% MODULATION

CARRIER SHIFT AT 95% MOD. (400u)

30	+1.0
50	+2.0
100	+2.2
400	+2.9
1000	+3
5000	+3
7500	+3.1
10,000	+3.3

0 %

NOISE LEVEL -62 DB.
BELOW 100% MOD.

PLATE HOURS 7.3

TEST DATA - METER READINGS

DATE 10-21-59

TYPE 316B SER. NO 22

FREQ. 740 kc / 640 kc

POWER OUTPUT

METER	SWITCH POSITION	READING	
		740	640
AC LINE VOLTAGE	A-B	220	220
	B-C	225	225
	A-C	230	230
PLATE VOLTAGE		7150	7300
ANTENNA CURR.		14.5 Amp	11.7 A.
SCREEN CURR.	UNMOD.	120 ma	70 ma
	95% MOD.	135 ma	130 ma
PLATE CURR.		3.45 A.	1.95 A.
TEST METER	OSC - K #1	10	
	#2		8
	BUFF - K	18	28
	DVR - G	28	26
	DVR - K	66	52
	PA - G	52	46
	PA1 - K	42	24
	PA2 - K	40	22
	PA3 - K	40	22
	1st AUD - K	36	36
	2nd AUD - K	27	27

RF OUTPUT CURR. IN	AMPERES	RESISTANCE
PHANTOM ANT.	14.6 11.7	740kc - 49 + j 16 640kc - 48.5 + j 15
TOWER BASE		
COMMON POINT		

PLATE HOURS

TEST DATA — VOLTAGE MEASUREMENTS TYPE 316B SER. NO. 22 FREQ. 740 kc / 640 kc

TUBE & TYPE	FUNCTION	MEASURE FROM	TO	VOLTAGE
V201 6AG7	OSCILLATOR	PLATE (J201J-4 & J201.2-4)	GROUND	200
V203 807	BUFFER	PLATE (C212)	GROUND	350
		SCREEN (PIN 2)	GROUND	170
		CATHODE (PIN 4)	GROUND	11.5
		FILA. (PIN 1)	FILA. (PIN 5)	6.2 AC
V204 4-65A	RF DRIVER	SCREEN (PINS 2 & 6)	GROUND	143
		GRID (PIN 4)	GROUND	-125
V206 807	1st AUDIO	PLATE (C241)	GROUND	270
		SCREEN (PIN 2)	GROUND	160
		CATHODE (PIN 4)	GROUND	16
		FILA. (PIN 1)	FILA. (PIN 5)	6.2 AC
V207 4-65A	2nd AUDIO	SCREEN (PINS 2 & 6)	GROUND	280
		CATH. (R258 C.T.)	GROUND	34
V210 807	MOD. REG.	FOR PA SCREEN VOLTAGE OF		385 VDC
		CATHODE (PIN 4)	GROUND	108
		CATHODE (PIN 4)	GRID (PIN 3)	-4.4 <i>105</i>
		SCREEN (PIN 2)	CATHODE (PIN 4)	65 <i>175</i>
		PLATE (R280)	CATHODE (PIN 4)	235 <i>340</i>

KCBS

TUNED CIRCUIT DATA

DATE 10-21-59

TYPE 316B SER. NO 22 FREQ. 740 kc / 640 kc

3OXT OSC. SER. NOS #1 244 #2 245

DRIVER PLATE CIRCUIT

COMPONENT	DESCRIPTION
L208	19 TURNS SHORTED
L221	NO TURNS 75 AWG 20 for 740 kc with 37 18 for 640 kc
C214	QTY. 200 MMF. 2
C215	QTY. 200 MMF. 6

RA. PLATE CIRCUIT

L216	at 740 kc 9 at 640 kc 4	TURNS SHORTED
L217	10	TURNS SHORTED
L218	12	TURNS SHORTED
[TUNING] C231.1	DIAL RDG. 16.1	
C231.2	1000	MMF.
C231.3	500	MMF.
C231.4		MMF.
[LOADING] C232.1	DIAL RDG. 17.8	
C232.2	1000	MMF.
C232.3	1000	MMF.
C232.4	1000 Variable set approx. mid-range	MMF.
C233.1	1000	MMF.
C233.2	500	MMF.

ABOVE FOR IMPEDANCE
OF _____ OHMS AT

PHANT. ANT.
TRANS. LINE
COMM. POINT

L218 (F.B.) AT 3 TAP FROM GROUND

18 db Feedback

SECTION 3. PREVENTIVE MAINTENANCE

3-1. Cleaning of Air Filters

Normally, the transmitter air filters will require cleaning every 30 to 60 days. In abnormally dusty climates, they should be visually inspected every two weeks and cleaned if required. The filters are of the permanent, washable type. Do not discard! Never subject the filters to temperatures above 212° F. Observe the following cleaning instructions:

1. Always wash with cool, clean water. If coating remains, a detergent can be used, followed by a rinse.
2. If it is impossible to immerse the filter, accumulation may be washed out by using a fine spray of water passed through the filter in a direction opposite that of the air flow arrows. Direct the water flow from the cleaner side to the dirty side of the filter.

CAUTION

Do not direct a high velocity stream of water against the filter. Do not disturb the normal distribution of the shredded material in the filter.

3. Gently shake water out of the filter.
4. Replace, with the air flow arrows pointing in the direction of the air flow.

3-2. Cleaning of Vacuum Capacitors and Vacuum Switch

The glass envelopes of the vacuum capacitors and vacuum switch should be dusted with a clean rag every 30-60 days or more often if a visible coating of dust appears on them. None of these components will require removal for cleaning.

3-3. Cleaning of Vacuum Tubes

The glass envelopes of all vacuum tubes, except the Type 4CX5000A, should be dusted with a clean rag every 30-60 days.

The Type 4CX5000A tubes should be removed from their sockets every 30 days and inspected for clogged fins. If dust has accumulated in the cooling fins, it can be removed by dusting downward, opposite

to the direction of the air flow, at the base of the fins. The ceramic body of the tube can be dusted with a clean rag. If any film appears, it can be washed with a damp rag containing detergent. Never attempt damp cleaning of a hot tube, however.

Raise the telescoping air exhaust ducts over the power amplifier tubes once every week, and remove any particles that may have dropped through.

3-4. Lubrication of Blower Motors

The Peerless blower motors are fitted with two Alemite grease nipples each. Each motor should receive an application of No. 1 grade grease (Lubriplate or equal) at the rate of one ounce every six months. In extremely hot climates, the frequency of lubrication should be increased to one ounce every three months.

3-5. Lubrication of Tuning Drives

The drive mechanism for the p-a plate tuning capacitor, C231.1, contains two right angle drives which may accumulate dust. In general, these will not require any attention. However, a thorough maintenance schedule would include the cleaning and greasing of these drives whenever the power amplifier tube plenum cover is removed, which may be every 60 days for dusting and inspection.

3-6. General

Although the performance and reliability of the equipment may not suffer from dust that settles on shelves, coils, transformer cases and on the floors, a clean looking transmitter is more pleasant to work on and suggests dependability to most observers. A general dusting and cleaning, when needed, is therefore advised.

The transmitter finish used inside and out is baked enamel. It can be cleaned with any non-abrasive automobile cleaner.

SECTION 4. TROUBLE-SHOOTING

4-1. Rectifier-Control Unit

Trouble - AIR indicator lamp fails to light although blowers are rotating in the proper direction.

Remedy - Look for clogged air filters, clogged fins in the power amplifier tubes or clogged outlet. If these are free of dust, check the adjustment of air switches S107 and S204.

Trouble - Filaments of tubes fail to light.

Remedy - If the AIR lamp is lighted, see that "P. A. Filament" breaker CB103, and "Bias" breaker CB104, are in the "ON" position.

Trouble - 7500 volt supply will come on but p-a tubes draw no current.

Remedy - LOW VOLTAGE breaker CB105 has tripped out. Restore it to ON position.

Trouble - 360 cycle hum is audible on carrier.

Remedy - Surge contactor K202 has failed to operate. Check thermistors RT201 and RT202. Short them out as an emergency measure and replace them later.

Trouble - 7500 volt rectifier trips off at high percentages of modulation.

Remedy - Check the setting of resistors R104, R105, and R106. They should all be set alike and should have about half of the resistor shorted out. This will allow the power amplifier tubes to draw approximately two amperes each before tripping out the 7500 volt rectifier.

4-2. Amplifier Unit

Trouble - All plate voltages are on but p-a tubes draw very little current and there is no antenna current.

Remedy - Check the operation of relay K201. If it fails to close, the r-f excitation will be removed. Check to see that the crystal is oscillating. This can be easily done by observing the oscillator tube cathode current on position 1 of the TEST METER. If the crystal oscillator is

functioning properly, the meter will indicate 10. If not, it will indicate higher, from 15 to 20.

Check the oscillator tube, V201. If the crystal has decreased in activity, sometimes a light tap on the glass envelope will start it. If this fails, hold the crystal in the palm of the hand for about 5 minutes to warm it. Replace when convenient.

Trouble - Power output from transmitter is too high or too low although no adjustments have been made.

Remedy - Measure the p-a screen voltage. If it has deviated more than ± 30 volts, replace dc amplifier tube V210. If trouble persists, check the operating voltages against the chart of typical readings. Observe that regulator tube V211 has a visible lavender glow. Observe that the p-a grid current (test meter position 5) has not changed.

Trouble - Unmodulated carrier has audible 60 or 120 cycle hum.

Remedy - Look for maladjustment of hum balance potentiometer R258. It should be set with the moving arm approximately centered. Fine adjustment will have to be made with a noise and distortion meter. It is suggested that this adjustment be made whenever audio driver tube V207 is changed.

Trouble - Transmitter is overmodulated at normal input level.

Remedy - Look for burned out feedback rectifier tube V209. Loss of overall feedback will require an input level 10 to 20 db lower than normal for 100% modulation.

4-3. General

Any trouble that may occur can generally be found by comparing the meter readings with the chart of typical meter readings or by observation of the indicator lamps. As the operator becomes more familiar with the circuitry involved, the sources of trouble will become easier to locate.

If the preventive maintenance schedule is followed and a record kept of the tube operating time, very little trouble can be anticipated. Replacement time for tubes can be predicted from the day to day meter indications, which will reveal their gradual deterioration.

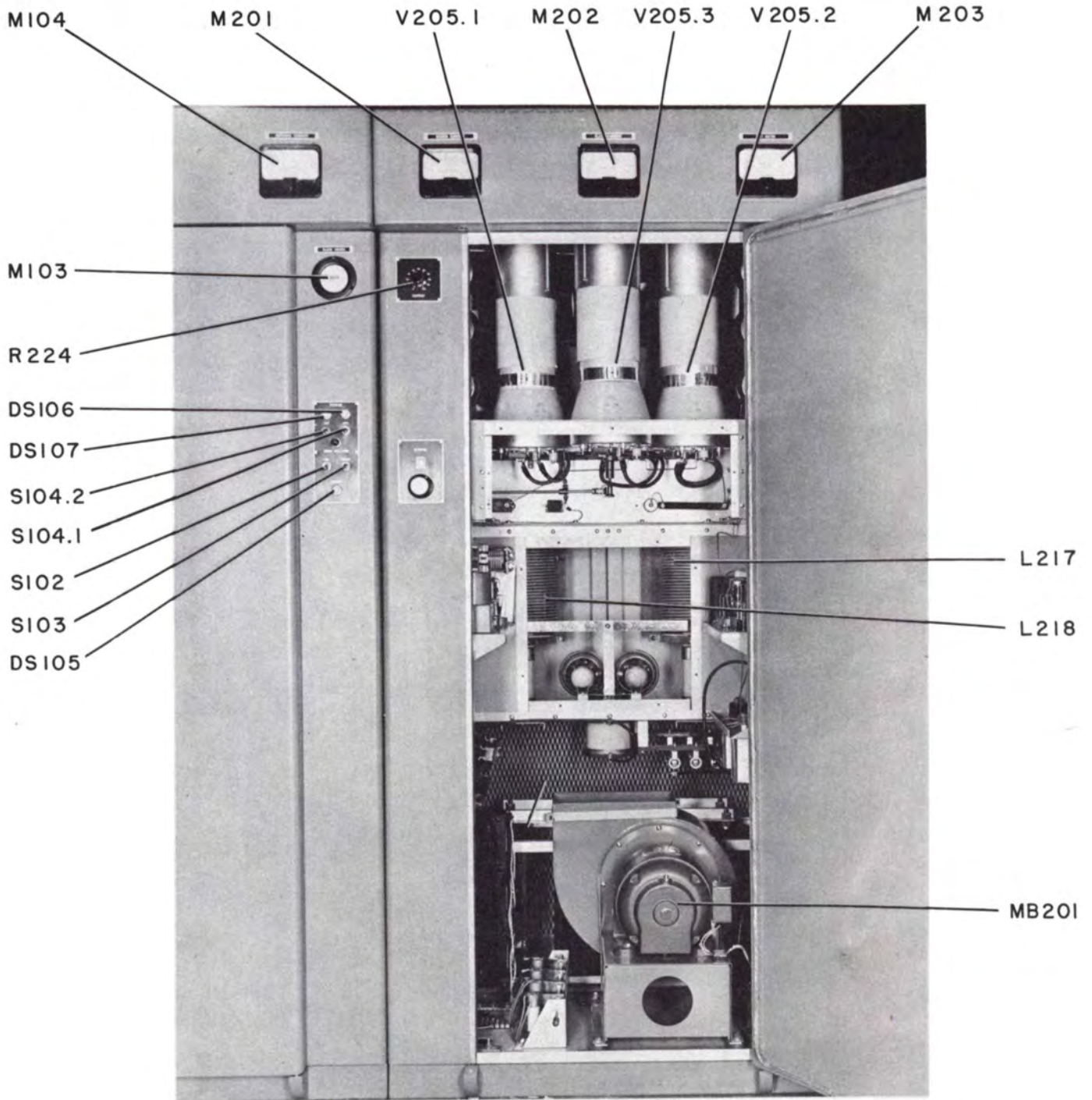

FIGURE 5-1
AMPLIFIER UNIT, FRONT VIEW

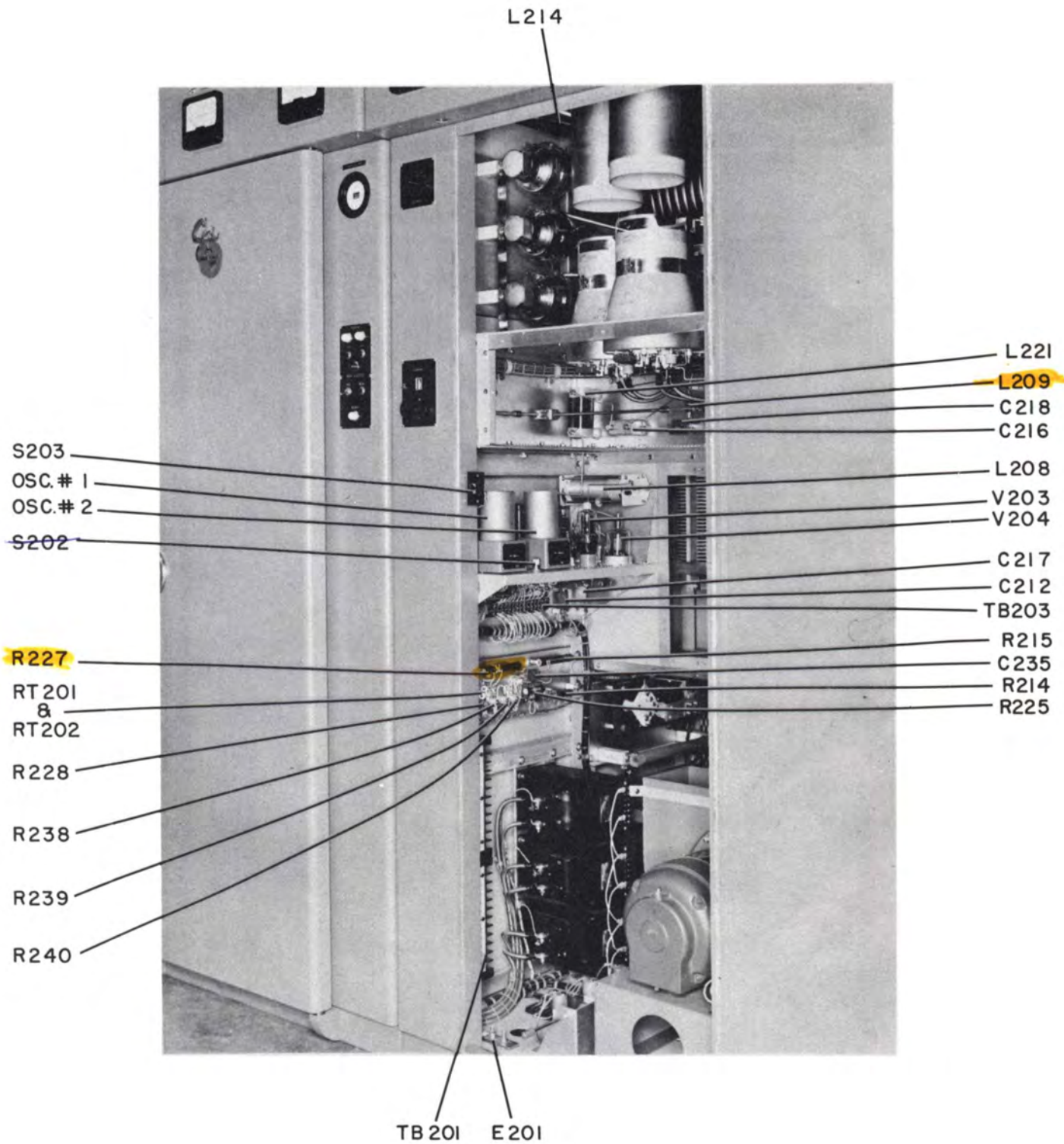

FIGURE 5-2
AMPLIFIER UNIT, LEFT SIDE

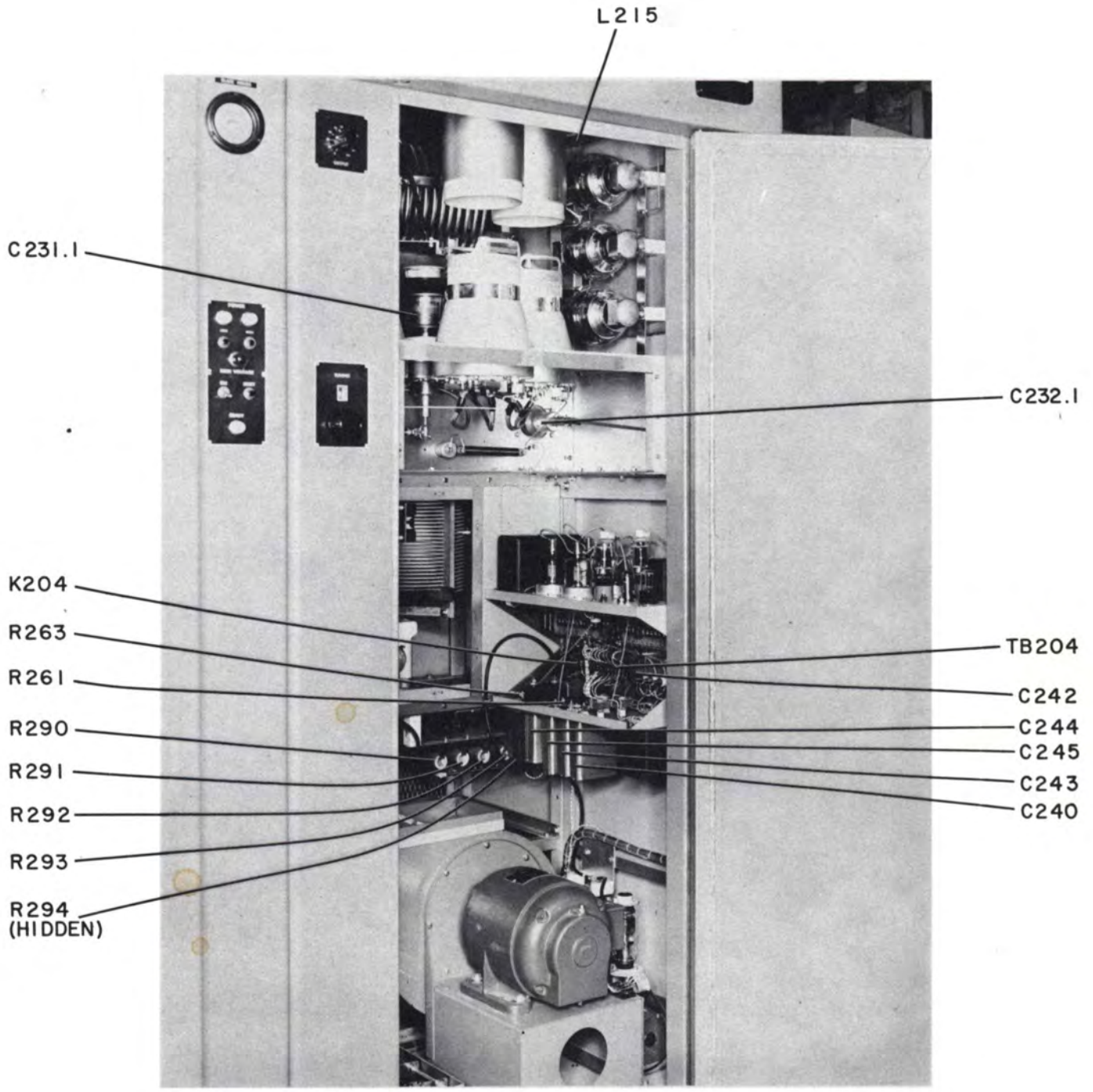

FIGURE 5-3
AMPLIFIER UNIT, RIGHT SIDE

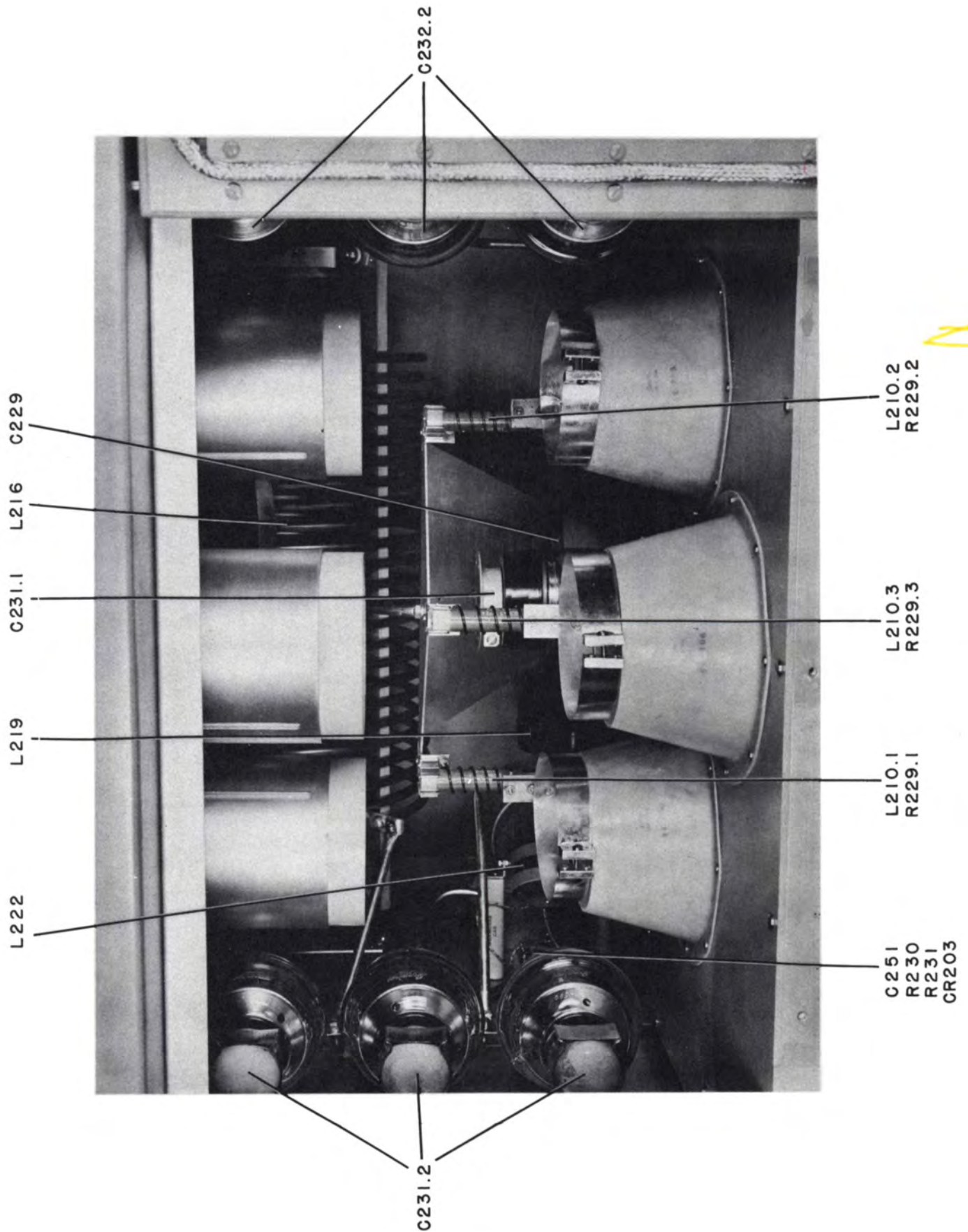

FIGURE 5-4
AMPLIFIER UNIT, UPPER PORTION

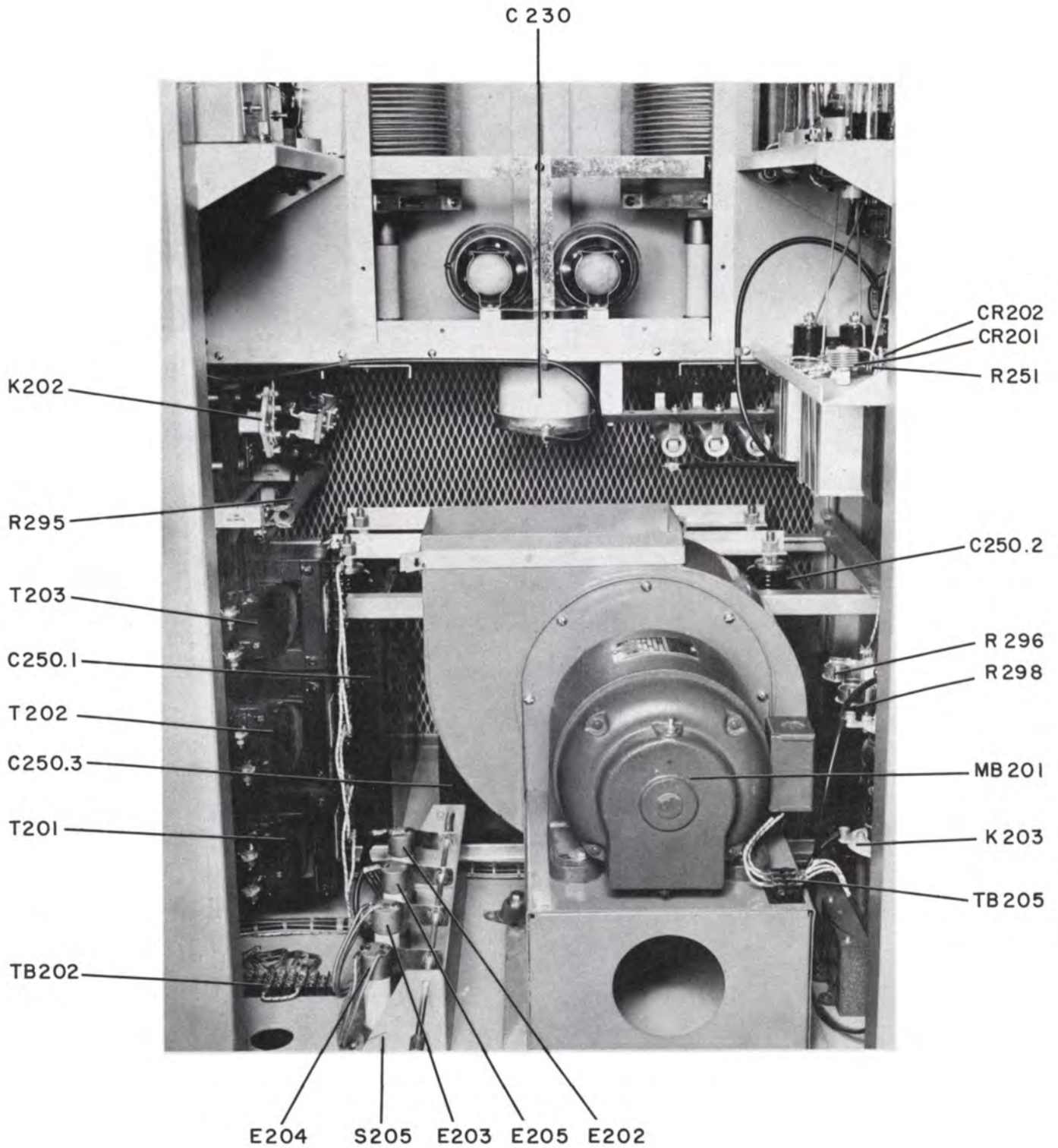

FIGURE 5-5
AMPLIFIER UNIT, LOWER PORTION

