



2019

Commercial Condensed Catalog



401 52 2205 19

September 2019

© 2019 International Comfort Products
Lewisburg, TN USA

MODEL NOMENCLATURE COMMERCIAL

SMALL PACKAGE UNITS

MODEL NOMENCLATURE											
MODEL SERIES	1	2	3	4	5,6	7,8,9	10	11,12	13	14	15
	P	G	D	4	36	090	K	00	0	E	1
<p>P = Package</p> <p>G = Gas/Electric</p> <p>D = Standard</p> <p>S = Mainline w/ SS HX</p> <p>3 = 13</p> <p>4 = 14</p> <p>5 = 15</p> <p>24 = 24,000 BTUH = 2 Tons</p> <p>30 = 30,000 BTUH = 2.5 Tons</p> <p>36 = 36,000 BTUH = 3 Tons</p> <p>42 = 42,000 BTUH = 3.5 Tons</p> <p>48 = 48,000 BTUH = 4 Tons</p> <p>60 = 60,000 BTUH = 5 Tons</p> <p>000 = no factory heat</p> <p>040 = 40,000 BTU/hr</p> <p>060 = 60,000 BTU/hr</p> <p>090 = 90,000 BTU/hr</p> <p>115 = 115,000 BTU/hr</p> <p>130 = 127,000 or 130,000 BTU/hr</p> <p>K = 208/230-1-60</p> <p>H = 208/230-3-60</p> <p>L = 460-3-60</p> <p>00 = No options</p> <p>TP = Tin Coated Copper Evap Main Tubes (single phase)</p> <p>GC = Low Cabinet Air Leakage plus Tin Coated Copper Evap Main Tubes (PGS4)</p> <p>GP = Tin Coated Copper Evap Main Tubes plus Stainless Steel Heat Exchanger (single phase)</p> <p>LC = Low Cabinet Air Leakage plus Tin Coated Copper Evap Main Tubes (PGD4)</p> <p>0 = Standard</p> <p>1 = Low NOx</p> <p>Sales Model Digit</p> <p>Engineering Digit</p>											
TYPE											
TIER											
SEER											
NOMINAL COOLING CAPACITY											
NOMINAL HEATING BTUH (input)											
VOLTAGE											
FACTORY INSTALLED OPTIONS											
FEATURE CODE											

COMMERCIAL SPLIT SYSTEM UNITS (3-5 Ton, Three-Phase)

OUTDOOR UNIT MODEL NUMBER IDENTIFICATION GUIDE (single phase)											
Digit Position:	1	2	3	4	5, 6	7	8	9	10	11	12
Example Part Number:	N	4	H	4	18	G	K	G	1	0	0
N = Entry Tier	TIER										
4 = R- 410A	REFRIGERANT										
H = Heat Pump	TYPE										
4 = 14 SEER	NOMINAL EFFICIENCY										
18 = 18,000 BTUH = 1½ tons 24 = 24,000 BTUH = 2 tons 30 = 30,000 BTUH = 2½ tons 36 = 36,000 BTUH = 3 tons 42 = 42,000 BTUH = 3½ tons 48 = 48,000 BTUH = 4 tons 60 = 60,000 BTUH = 5 tons											
		NOMINAL CAPACITY									
G = Coil Guard Grille, 3/8 (10mm) spacing						FEATURES					
K = 208/230- 1- 60 H = 208/230- 3- 60 L = 460- 3- 60						VOLTAGE					
Sales Code											
Engineering Revision											
Extra Digit											
Extra Digit											

RAS MODEL NUMBER NOMENCLATURE

MODEL SERIES	R	A	S	0	9	0	H	0	A	A	0	A	A	A
Position Number	1	2	3	4	5	6	7	8	9	10	11	12	13	14
R = Rooftop														
A = Electric/Electric, Cooling Only	Type													
S = Standard DOE/ASHRAE 90.1 Efficiency	Efficiency													
072 = 6 Tons (1 circuit/one stage cooling) 089 = 7.5 Tons (1 circuit/two stage cooling) 090 = 7.5 Tons (2 compressor/two stage cooling) 100 = 8.5 Tons (1 circuit/two stage cooling) 102 = 8.5 Tons (2 compressor/two stage cooling) 119 = 10 Tons (1 circuit/two stage cooling) 120 = 10 Tons (2 compressor/two stage cooling) 150 = 12.5 Tons (2 compressor/two stage cooling) 180 = 15 Tons (2 compressor/two stage cooling)														
Nominal Cooling Capacity														
H = 208/230-3-60 L = 460-3-60 S = 575-3-60														
Voltage														
0 = No Heat														
Heating Capacity														
A = Standard Motor/Drive B = High Static Motor/Drive ¹ C = Medium Static Motor/Drive E = High Static - High Efficiency Motor/Drive G = High Static Motor/Drive with Hot Gas Re-Heat (RAS180 only) H = High Static Motor/Drive with Hot Gas Re-Heat (not available on 089, 100, 119 models)														
Motor Option														
A = None B = Low Leak Economizer w/Barometric relief, OA Temperature Sensor E = Low Leak Economizer w/Barometric relief and CO ₂ Sensor, OA Temperature Sensor H = Low Leak Economizer w/Barometric relief, Enthalpy Sensor L = Low Leak Economizer w/Barometric relief and CO ₂ Sensor, Enthalpy Sensor P = 2-Position Damper (non U.S. models only) U = Temperature Ultra Low Leak Economizer w/Barometric relief W = Enthalpy Ultra Low Leak Economizer w/Barometric relief														
Outdoor Air Options														
0A = Standard (no options) AT = Un-Powered Convenience Outlet 4B = Non-Fused Disconnect Switch BB = Powered Convenience Outlet BR = Supply Air Smoke Detector BP = Return Air Smoke Detector AA = Easy Access Hinged Panels														
Factory Installed Options²														
A = Aluminum/Copper Condenser and Evaporator Coil B = Precoat Alum/Cu Condenser and Alum/Cu Evaporator C = E-Coated Alum/Cu Condenser and Alum/Cu Evaporator D = E-Coated Alum/Cu Condenser and Evaporator E = Cu/Cu Condenser and Alum/Cu Evaporator F = Copper/Copper Condenser and Evaporator														
Standard Condenser / Evaporator Coil Configuration														
A = Single-Speed Indoor Fan Motor, for W7212 controls B = Single-Speed Indoor Fan Motor, for W7220 controls T = Two-Speed Indoor Motor Controller (VFD) - Standard on U.S. models (except 089, 100, 119 models)														
Indoor Fan Motor														

¹ Not available for RAS089 units.

² Combinations of FIOPS are available. Contact your sales representative for details.

RHS 072-150 MODEL NUMBER NOMENCLATURE

MODEL SERIES	R	H	S	0	9	0	H	0	A	A	0	A	A	T
Position Number	1	2	3	4	5	6	7	8	9	10	11	12	13	14
R = Rooftop														
H = Heat Pump		Type												
S = Standard DOE/ASHRAE 90.1 Efficiency		Efficiency												
072 = 6 Tons (1 circuit/one stage cooling)														
090 = 7.5 Tons (2 compressor/two stage cooling)														
102 = 8.5 Tons (2 compressor/two stage cooling)														
120 = 10 Tons (2 compressor/two stage cooling)														
150 = 12.5 Tons (2 compressor/two stage cooling)		Nominal Cooling Capacity												
H = 208/230-3-60														
L = 460-3-60														
S = 575-3-60		Voltage												
0 = No Heat		Heating Capacity												
A = Standard Motor/Drive														
B = High Static Motor/Drive														
C = Medium Static Motor/Drive														
E = High Static - High Efficiency Motor/Drive		Motor Option												
A = None														
B = Low Leak Economizer w/Barometric relief, OA Temperature Sensor														
E = Low Leak Economizer w/Barometric relief and CO ₂ Sensor, OA Temperature Sensor														
H = Low Leak Economizer w/Barometric relief, Enthalpy Sensor														
L = Low Leak Economizer w/Barometric relief and CO ₂ Sensor, Enthalpy Sensor														
P = 2-Position Damper														
U = Temperature Ultra Low Leak Economizer w/Barometric relief														
W = Enthalpy Ultra Low Leak Economizer w/Barometric relief		Outdoor Air Options												
0A = Standard (no options)														
AT = Un-Powered Convenience Outlet														
4B = Non-Fused Disconnect Switch														
BB = Powered Convenience Outlet														
BR = Supply Air Smoke Detector														
BP = Return Air Smoke Detector														
AA = Easy Access Hinged Panels		Factory Installed Options¹												
A = Aluminum/Copper Condenser and Evaporator Coil														
B = Precoat Alum/Cu Condenser and Alum/Cu Evaporator														
C = E-Coated Alum/Cu Condenser and Alum/Cu Evaporator														
D = E-Coated Alum/Cu Condenser and Evaporator														
E = Cu/Cu Condenser and Alum/Cu Evaporator														
F = Copper/Copper Condenser and Evaporator		Standard Condenser / Evaporator Coil Configuration												
A = Single-Speed Indoor Fan Motor, for W7212 controls														
B = Single-Speed Indoor Fan Motor, for W7220 controls														
T = Two-Speed Indoor Motor Controller (VFD) - Standard on U.S. models		Indoor Fan Motor												

¹ Not all combinations of factory installed options are available. Contact your sales representative for details.

RHS 181-243 MODEL NOMENCLATURE

MODEL SERIES	R	H	S	1	8	1	H	0	A	B	0	A	A	A
Position Number	1	2	3	4	5	6	7	8	9	10	11	12	13	14
R = Rooftop H = Heat Pump A = Air Conditioning (Cooling Only) G = Gas/Electric														
Type														
S = Standard ASHRAE 90.1-2010 Efficiency														
Efficiency														
181 = 181,000 = 15 Tons Dedicated Vertical SA/RA (SA = Supply Air, RA = Return Air) 183 = 180,000 = 15 Tons Dedicated Horizontal SA/RA 240 = 240,000 = 20 Tons Dedicated Vertical SA/RA 243 = 240,000 = 20 Tons Dedicated Horizontal SA/RA														
Nominal Cooling Capacity														
H = 208/230-3-60 L = 460-3-60 S = 575-3-60														
Voltage														
0 = No Heat														
Heating Capacity														
A = Standard Option (not available on horizontal 243 unit) B = High Static Option (15 ton only w/ 1-Speed IFM, 15 & 20 Ton with 2-Speed IFM) E = High Static Option - High Efficiency Motor (20 ton only w/ 1-Speed IFM) C = Medium Static Motor (15 ton only w/ 1-Speed IFM, 15 & 20 Ton with 2-Speed IFM) F = Medium Static Option - High Efficiency Motor (20 ton only w/ 1-Speed IFM)														
Motor Option														
A = None B = Economizer w/Baro-relief, OA Temp sensor E = Economizer w/Baro-relief + CO ₂ sensor, OA Temp sensor H = Economizer w/Baro-relief, Enthalpy sensor L = Economizer w/Baro-relief + CO ₂ sensor, Enthalpy sensor U = Ultra Low Leak Temp Economizer w/Baro-relief W = Ultra Low Leak Enthalpy Economizer w/Baro-relief P = 2-Position damper w/Baro-relief														
Outdoor Air Options / Control														
0A = No Options 4B = Non-fused Disconnect AT = Non-powered 115v Convenience Outlet AA = Hinged Access Panels BR = Supply Air Smoke Detector														
Factory Installed Options														
A = Standard - Alum. Fin / Copper Tubes, Condenser & Evap B = Pre-coated Alum. Fin / Copper Tubes Condenser Coils, Standard Evap. Coil C = E-Coated Alum. Fin / Copper Tubes Condenser Coils, Standard Evap. Coil D = E-Coated Alum. Fin / Copper Tubes Condenser & Evap. Coils E = Copper Fin / Copper Tube Condenser Coils, Standard Evap. Coil F = Copper Fin / Copper Tube Condenser & Evap Coils														
Condenser / Evaporator Coil Configuration														
A = Standard Motor T = 2 Speed Indoor Fan VFD Controller (For 2-stage units only)														
Motor Type Option														

RGH 036-150 MODEL NUMBER NOMENCLATURE

MODEL SERIES	R	G	H	0	9	0	H	D	A	A	0	A	A	A
Position Number	1	2	3	4	5	6	7	8	9	10	11	12	13	14
R = Rooftop														
G = Gas/Electric	Type													
H = High-Efficiency	Efficiency													
036=3Tons	090=7.5Tons(DualCompressor)													
048=4Tons	102=8.5Tons(DualCompressor)													
060=5Tons	110=10Tons(DualCompressor)(12.0EER)													
072=6Tons(SingleCompressor/SingleStage)	120=10Tons(DualCompressor)(11.5EER)													
073=6Tons(SingleCompressor/2-Stage)	150=12.5Tons(DualCompressor)													
Nominal Cooling Capacity														
K=208/230-1-60	L=460-3-60													
H=208/230-3-60	S=575-3-60													
Voltage														
D=Low Heat	L=Low Heat, Low NOx*													
E=Medium Heat	M=Medium Heat, Low NOx*													
F=High Heat	N=High Heat, Low NOx*													
S=Low Heat, Stainless Steel Heat Exchanger														
R=Medium Heat, Stainless Steel Heat Exchanger														
T=High Heat, Stainless Steel Heat Exchanger														
Heating Capacity (See spec sheet for actual capacity)														
X = Direct drive ECM motor														
A = Standard Motor – (Belt Drive) (Not available on 3 – 5 ton)														
C = Medium Static Option (Belt Drive) (All 3 phase models)														
B = High Static Option (Belt Drive)(All 3 phase, 1 speed IFM except RGH150) (All 2 speed IFM models)														
E = High Static - High-Efficiency Motor (Belt Drive) (RGH150 with 1 speed IFM)														
G = High Static Motor with Hot Gas Re-Heat (Belt Drive) (1 speed IFM – RGH150 only)														
H = High Static Motor with Hot Gas Re-Heat (Belt Drive) (All sizes with 1 speed IFM except RGH110 & 150) (All sizes with 2 speed IFM except RGH110)														
Motor Option														
A = None														
B = Economizer w/Barometric relief, OA Temp sensor														
E = Economizer w/Barometric relief + CO ₂ Sensor, OA Temp sensor														
H = Enthalpy Economizer w/Barometric relief, enthalpy sensor	No factory - installed economizers for single phase													
L = Enthalpy Economizer w/Barometric relief + CO ₂ Sensor, enthalpy sensor														
U = Temp Ultra Low Leak Economizer w/Barometric relief														
W = Enthalpy Ultra Low Leak Economizer w/Barometric relief														
P = 2-Position damper w/Baro-relief only on 1-speed unit														
Outdoor Air Options/Control														
0A = Standard														
BB = Powered 115v Convenience Outlet														
AT = Non-powered 115v Convenience Outlet														
4B = Non-Fused Disconnect														
BR = Supply Air Smoke Detector														
AA = Easy Access Hinged Panels														
Factory Installed Options (Not available on 1 phase models)														
A = Aluminum / Copper Cond & Alum/Copper Evap Coil	D = E-Coated Alum/Cu Cond & Evap													
B = Pre-coat Alum/Copper Cond & Alum / Copper Evap (3 Phase only)	E = Cu/Cu Cond & Alum/Cu Evap													
C = E-Coated Alum/Copper Cond & Alum / Copper Evap (3 Phase only)	F = Copper/Copper Cond & Evap													
Condenser / Evaporator Coil Configuration														
A = Standard Single Speed Indoor Fan Motor For W7212 controls														
B = Standard Single Speed Indoor Fan Motor For W7220 controls														
T = 2 Speed Indoor Fan VFD Controller (For 2-stage units only)														
Motor Type Option														

*RGH 3 to 5 ton models only

NOTE: On single phase (K voltage code) models, the following are not available as factory installed options:

- Coated or copper fin coils
- Economizers or 2 position dampers
- Hot Gas Reheat

RGH 181-303 MODEL NUMBER NOMENCLATURE

MODEL SERIES	R	G	H	1	8	1	H	D	A	B	0	A	A	A
Position Number	1	2	3	4	5	6	7	8	9	10	11	12	13	14
R = Rooftop														
G = Gas/Electric Type														
H = High Efficiency Efficiency														
181 = 181,000 = 15 Tons Dedicated Vertical SA/RA (SA = Supply Air, RA = Return Air) 183 = 180,000 = 15 Tons Dedicated Horizontal SA/RA 210 = 210,000 = 17.5 Tons Dedicated Vertical SA/RA 213 = 210,000 = 17.5 Tons Dedicated Horizontal SA/RA 240 = 240,000 = 20 Tons Dedicated Vertical SA/RA 243 = 240,000 = 20 Tons Dedicated Horizontal SA/RA 300 = 300,000 = 25 Tons Dedicated Vertical SA/RA 303 = 300,000 = 25 Tons Dedicated Horizontal SA/RA Nominal Cooling Capacity														
H = 208/230-3-60 L = 460-3-60 S = 575-3-60 Voltage														
D = Low Heat E = Medium Heat F = High Heat S = Low Heat, Stainless Steel Heat Exchanger R = Medium Heat, Stainless Steel Heat Exchanger T = High Heat, Stainless Steel Heat Exchanger Heating Capacity														
A = Standard Motor (All sizes) C = Medium Static Motor (15 & 17.5 ton with 1 speed IFM, All sizes with 2 speed IFM) B = High Static Motor (15 ton with 1 speed IFM, All sizes with 2 speed IFM) E = High Static - High Efficiency Motor (17.5 to 25 ton with 1 speed IFM) F = Medium Static - High Efficiency Motor (20 & 25 ton with 1 speed IFM) G = High Static Motor/Drive with Hot Gas Reheat (All sizes with 1 speed IFM) Motor Option														
A = None B = Temp Economizer w/Baro-relief E = Temp Economizer w/Baro-relief + CO ₂ sensor H = Enthalpy Economizer w/Baro-relief L = Enthalpy Economizer w/Baro-relief + CO ₂ sensor U = Temp. Ultra Low Leak Economizer w/Baro-relief W = Enthalpy Ultra Low Leak Economizer w/Baro-relief P = 2-Position damper Outdoor Air Options / Control														
OA = No Options 4B = Non-Fused Disconnect AA = Hinged Access Panels AT = Non-powered 115v C.O. BB = Powered Convenience Outlet BP = Return-Air Smoke Detector BR = Supply-Air Smoke Detector Factory Installed Options														
A = Aluminum Fin /Copper Tubes Cond & Evap Coil B = Precoat Aluminum/Copper Cond Coil C = E-Coated Cond Coil Condenser / Evaporator Coil Configuration														
A = Standard Motor T = 2 Speed Indoor Fan VFD Controller (For 2-stage units only) Motor Type Option														

RAH 036-150 MODEL NUMBER NOMENCLATURE

MODEL SERIES	R	A	H	0	9	0	H	0	A	A	0	A	A	A
Position Number	1	2	3	4	5	6	7	8	9	10	11	12	13	14
R = Rooftop														
A = Air Conditioning (Cooling Only) Type														
H = High Efficiency Efficiency														
036 = 3 Tons 090 = 7.5 Tons (Dual Compressor) 048 = 4 Tons 102 = 8.5 Tons (Dual Compressor) 060 = 5 Tons 110 = 10 Tons (Dual Compressor) 12.0 EER* 072 = 6 Tons (Single Compressor/Single-Stage) 120 = 10 Tons (Dual Compressor) 11.7 EER* 073 = 6 Tons (Single Compressor/2-Stage) 150 = 12.5 Tons (Dual Compressor)														
Nominal Cooling Capacity														
K = 208/230-1-60 L = 460-3-60														
H = 208/230-3-60 S = 575-3-60 Voltage														
0 = No Heat Heating Capacity (See spec sheet for actual capacity)														
X = Direct drive ECM motor (3-5 Ton All voltages 1 & 3 phase) A = Standard Static Option - (Belt Drive) 6-12.5 Ton with 1 speed IFM, 3 phase only C = Medium Static Option (Belt Drive) (3-12.5 Ton with 1 speed IFM, 3 phase only) B = High Static Option (Belt Drive) (3-10 Ton with 1 speed IFM, 3 phase only) E = High Static High Efficiency Option (Belt Drive) (12.5 Ton with 1 speed IFM) G = High Static Motor / Drive with Hot Gas Re-heat (12.5 Ton with 1 speed IFM) H = High Static Motor / Drive with Hot Gas Re-heat (3-10 Ton with 1 speed IFM, 7.5 to 12.5 ton with 2 speed IFM)														
Motor Option														
A = None B = Economizer w/Barometric relief, OA Temp sensor E = Economizer w/Barometric relief + CO ₂ Sensor, OA Temp sensor H = Economizer w/Barometric relief, enthalpy sensor No more factory installed economizers for single phase L = Economizer w/Barometric relief + CO ₂ Sensor, enthalpy sensor P = 2-Position damper w/Baro-relief U = Temp Ultra Low Leak Economizer w/Barometric relief W = Enthalpy Ultra Low Leak Economizer w/Barometric relief														
Outdoor Air Options / Control (See spec sheet for details)														
OA = No Options 4B = Non-Fused Disconnect BB = Powered 115v Convenience Outlet AT = Non-powered 115v Convenience Outlet BR = Supply Air Smoke Detector AA = Easy Access Hinged Panels														
Factory Installed Options														
A = Aluminum / Copper Cond & Alum/Copper Evap Coil B = Pre-coat Alum/Copper Cond & Alum / Copper Evap C = E-Coated Alum/Copper Cond & Alum / Copper Evap D = E-Coated Alum / Copper Cond & E-Coated Alum/Copper Evap E = Copper/Copper Cond & Alum/Copper Evap F = Copper/Copper Cond & Copper/Copper Evap														
Condenser / Evaporator Coil Configuration														
A = Standard Single Speed Indoor Fan Motor For W7212 controls B = Standard Single Speed Indoor Fan Motor For W7220 controls T = 2-Speed Indoor Fan VFD Controller (For 2-stage units only)														
Motor Type Option														

NOTE: On single phase (K voltage code) models, the following are not available as factory installed options:

- Coated or copper fin coils
- Economizers or 2 position dampers
- Hot Gas Re-heat

* Two speed fan is required for sale in the U.S. or Canada.

RAH 181-303 MODEL NUMBER NOMENCLATURE

MODEL SERIES	R	A	H	1	8	1	H	0	A	A	0	A	A	A
Position Number	1	2	3	4	5	6	7	8	9	10	11	12	13	14
R = Rooftop														
A = Air Conditioning Type														
H = High Efficiency Efficiency														
181 = 181,000 = 15 Tons Dedicated Vertical SA/RA (SA = Supply Air, RA = Return Air) 183 = 180,000 = 15 Tons Dedicated Horizontal SA/RA 210 = 210,000 = 17.5 Tons Dedicated Vertical SA/RA 213 = 210,000 = 17.5 Tons Dedicated Horizontal SA/RA 240 = 240,000 = 20 Tons Dedicated Vertical SA/RA 243 = 240,000 = 20 Tons Dedicated Horizontal SA/RA 300 = 300,000 = 25 Tons Dedicated Vertical SA/RA 303 = 300,000 = 25 Tons Dedicated Horizontal SA/RA Nominal Cooling Capacity														
H = 208/230-3-60 L = 460-3-60 S = 575-3-60 Voltage														
0 = No Heat Heating Capacity														
A = Standard Motor (All sizes) C = Medium Static Motor (15 & 17.5 ton with 1 speed IFM, All sizes with 2 speed IFM) B = High Static Motor (15 ton with 1 speed IFM, All sizes with 2 speed IFM) E = High Static - High Efficiency Motor (17.5 to 25 ton with 1 speed IFM) F = Medium Static - High Efficiency Motor (20 & 25 ton with 1 speed IFM) G = High Static Motor with Hot Gas Reheat (17.5-25 ton) H = High Static Motor with Hot Gas Reheat (15 ton with 1 speed IFM, 15 to 25 ton with 2 speed IFM) Motor Option														
A = None B = Low Leak Economizer w/Baro-relief, OA Temp sensor (W7212 or W7220 available) E = Low Leak Economizer w/Baro-relief + CO ₂ sensor, OA Temp sensor (W7212 or W7220 available) H = Low Leak Economizer w/Baro-relief, Enthalpy sensor (W7212 or W7220 available) L = Low Leak Economizer w/Baro-relief + CO ₂ sensor, Enthalpy sensor (W7212 or W7220 available) U = Ultra Low Leak Temp Economizer w/Baro relief (W7220 only) W = Ultra Low Leak Enthalpy Economizer w/Baro relief (W7220 only) P = 2-Position damper w/Baro-relief Outdoor Air Options / Control*														
0A = No Options 4B = Non-Fused Disconnect AT = Non-powered 115v C.O. BR = Supply Air Smoke Detector AA = Easy Access Hinged Panels BB = Powered 115v C.O. BP = Return Air Smoke Detector Factory Installed Options														
A = Aluminum/Copper Cond & Evap Coil B = Precoat Aluminum/Copper Cond & Alum/Copper Evap Coil C = E-Coated Aluminum/Copper Cond & Alum/Copper Evap Coil D = E-Coated Aluminum/Copper Cond & E-Coated Aluminum/Copper Cond Evap Coil E = Copper/Copper Cond & Aluminum/Copper Evap F = Copper/Copper Cond & Copper/Copper Evap Condenser / Evaporator Coil Configuration														
A = Single Speed IFM set up for W7212 controller B = Single Speed IFM set up for W7220 controller T = Two Speed IFM set up for W7220 controller Motor Type Option														

* W7212 must have "A" in Motor Type Position; W7220 must have "B" in Motor Type Position.

RHH MODEL NUMBER NOMENCLATURE

Position	1	2	3	4	5	6	7	8	9	10	11	12	13	14							
Example	R	H	H	0	7	2	L	0	A	B	0	A	A	A							
R = Rooftop		H = Heat Pump Unit TYPE		H = High Efficiency EFFICIENCY ASHRAE 90.1 / Energy Star		036 = 36,000 BTUH = 3 Tons 048 = 48,000 BTUH = 4 Tons 060 = 60,000 BTUH = 5 Tons 072 = 72,000 BTUH = 6 Tons (1-Stage Cooling) 073 = 72,000 BTUH = 6 Tons (2-Stage Cooling) 090 = 90,000 BTUH = 7.5 Tons (2 Compressor) 102 = 102,000 BTUH = 8.5 Tons (2 Compressors) 120 = 120,000 BTUH = 10 Tons (2 Compressors) NOMINAL COOLING CAPACITY		H = 208/230-3-60 K = 208/230-1-60 L = 460-3-60 S = 575-3-60 VOLTAGE		0 = No Heat - Field Installed Only ELECTRIC HEATING CAPACITY (See Spec Sheet for Actual Capacity)		X = Direct Drive - X13 A = Standard Motor / Drive - Belt Drive B = High Static Motor / Drive - Belt Drive E = High Static - Efficient Motor / Drive - Belt Drive C = Medium Static Motor / Drive - Belt Drive MOTOR (Indoor Fan)		A = None B = Temp Economizer w/Baro-relief E = Temp Economizer w/Baro-relief + CO2 Sensor H = Enthalpy Economizer w/Baro-relief L = Enthalpy Economizer w/Baro-relief + CO2 Sensor U = Temp Ultra Low Leak Economizer w/Baro-relief W =Enthalpy Ultra Low Leak Economizer w/Baro-relief P = 2-Position damper OUTDOOR AIR OPTIONS / CONTROL (See Spec Sheet for Details)		0A = Standard AT = Un - Powered Convenience Outlet 4B = Non Fused Disconnect Switch BB = Powered Convenience Outlet BR = Supply Air Smoke Detector BP = Return Air Smoke Detector AA = Easy Access Hinged Panels OTHER FACTORY INSTALLED OPTIONS (See Spec Sheet for details)		A = Aluminum / Copper Cond & Evap Coil B = Precoat Alum/CU Cond & Alum / CU Evap C = E-Coated Alum/Cu Cond & Alum / CU Evap D = E-Coated Alum / Cu Cond & Evap E = Cu / Cu Cond & Alum/Cu Evap F = Copper/Copper Cond & Evap COIL FACTORY INSTALLED OPTIONS (See Spec Sheet for Details)		A = Standard Single Speed Indoor Fan Motor. For W7212 controls B = Standard Single Speed Indoor Fan Motor. For W7220 controls T = 2-Speed Indoor Motor Controller (VFD) INDOOR FAN MOTOR	

CAS MODEL NUMBER NOMENCLATURE

MODEL SERIES	C	A	S	0	9	1	H	A	A	0	A	0	0	A
Position Number	1	2	3	4	5	6	7	8	9	10	11	12	13	14
C = R-410A Condensing Unit														
A = Air Conditioning (Cooling Only) Type														
S = Standard ASHRAE 90.1-2010 Efficiency Efficiency														
072 = 71,000 BTUH = 6 Tons 091 = 92,000 BTUH = 7.5 Tons (1 circuit) 120 = 117,000 BTUH = 10 Tons (2 circuit) 121 = 117,000 BTUH = 10 Tons (1 circuit) 150 = 148,000 BTUH = 12.5 Tons (2 circuit) 151 = 148,000 BTUH = 12.5 Tons (1 circuit) 180 = 180,000 BTUH = 15 Tons (2 circuit) 181 = 180,000 BTUH = 15 Tons (1 circuit) 240 = 240,000 BTUH = 20 Tons (2 circuit) 241 = 240,000 BTUH = 20 Tons (1 circuit) Nominal Cooling Capacity														
H = 208/230-3-60 L = 460-3-60 S = 575-3-60 Voltage														
A = Single Circuit B = Single Circuit w/ Low Ambient Control D = Dual Circuit E = Dual Circuit w/ Low Ambient Control G = Single Circuit 2 Stage (072 & 091 models only) H = Single Circuit 2 Stage w/ Low Ambient Control (072 & 091 models only) Refrigerant System Options														
A = Cu/Al Cond. RTPF B = Precoat Al/Cu Cond. RTPF C = E-Coat Al/Cu Cond. RTPF E = Cu/Cu Cond. RTPF Outdoor Coil Options														
0 = None 1 = Non-powered 115v Convenience Outlet Service Options														
A = None C = Non-Fused Disconnect Switch Electrical Options														
0 = Standard Elec-Mechanical Control Base Unit Controls														
0 = No options, reserved for future Use Future Use														
A = Original Design Sales Digit														

CHS MODEL NUMBER NOMENCLATURE

MODEL SERIES	C	H	S	0	9	1	H	A	A	0	A	0	0	A
Position Number	1	2	3	4	5	6	7	8	9	10	11	12	13	14
C = R-410A Condensing Unit														
H = Heat Pump Type														
S = Standard ASHRAE 90.1-2010 Efficiency Efficiency														
072 = 6 Tons (Single Compressor) 091 = 7.5 Tons (Single Compressor) 121 = 10 Tons (Single Compressor) 180 = 15 Tons (Dual Compressor) 240 = 20 Tons (Dual Compressor) Nominal Cooling Capacity														
H = 208/230-3-60 L = 460-3-60 S = 575-3-60 Voltage														
A = Single Circuit B = Single Circuit w/ Low Ambient Control D = Dual Circuit E = Dual Circuit w/ Low Ambient Control G = Single Circuit, 2-stage (072, 091, 120 models only) H = Single Circuit, 2-stage w/ Low Ambient Control (072, 091, 120 models only) Refrigerant System Options														
A = Standard Al Fin / Copper Tube B = Pre-Coated Al Fin / Copper Tube C = E-Coat Al Fin / Copper Tube Outdoor Coil Options														
0 = None 1 = Non-powered 115v Convenience Outlet Service Options														
A = None C = Non-Fused Disconnect Electrical Options														
0 = Standard Electrical Mechanical Base Unit Controls														
0 = No Options Future Use														
A = Original Design														

FAS MODEL NUMBER NOMENCLATURE

MODEL SERIES	F	A	S	0	9	1	M	A	A	A	0	A	0	A
Position Number	1	2	3	4	5	6	7	8	9	10	11	12	13	14
F = R-410A Fan Coil Unit														
A = Air Conditioning (Cooling Only)														
Type														
S = Standard Efficiency														
Efficiency														
072 = 6 Tons (1 circuit) 091 = 7.5 Tons (1 circuit) 120 = 10 Tons (2 circuit) 150 = 12.5 Tons (2 circuit) 180 = 15 Tons (2 circuit) 240 = 20 Tons (2 circuit) 300 = 25 Tons (2 circuit) 336 = 30 Tons (2 circuit)														
Nominal Tonnage														
K = 208/230-1-60 H = 208/230-3-60 M = 460/208/230-3-60 L = 460-3-60 S = 575-3-60														
Voltage														
A = Standard Static Standard Efficiency Motor / Standard Drive • 6 to 15 ton 208/230v, 460v, 575v-3-60, 6 and 7.5 ton 208/230-1-60, 1-speed • all 2-speed B = High Static Standard Efficiency Motor / High Drive • 6 to 15 ton 208/230V, 460v, 6 to 10 ton 575v-3-60, 1-speed • all 2-speed D = Standard Static High Efficiency Motor / Standard Drive • 20, 25, 30 ton all 3 phase E = High Static High Efficiency Motor / High Drive • 15 to 30 ton all 3 phase														
Fan Motor Options														
A = Cu/Al														
Indoor Coil														
A = Future Use														
Future Use														
0 = Single Speed Indoor Fan Motor 2 = Two Speed Indoor Fan Motor Controller (VFD)														
Fan Speed Controller														
A = Standard - Unpainted B = Painted cabinet (Gray)														
Painted Cabinet Options														
0 = Future Use														
Future Use														
A = Standard														

NOTES:

1. All FAS072-150 units with a "M" voltage designation are triple voltage; i.e., 208/230/460-3-60. FAS 180 units are also triple voltage in the "M" configuration unless the High Static motor option is used. "M" voltage is not available on 2-speed indoor fan motor option.
2. Single-phase 072 and 091 units designate standard motor and high static drive.

FHS MODEL NUMBER NOMENCLATURE

MODEL SERIES	F	H	S	0	9	1	M	A	A	A	0	A	0	A
Position Number	1	2	3	4	5	6	7	8	9	10	11	12	13	14
F = R-410A Fan Coil Unit														
H = Heat Pump		Type												
S = Standard Efficiency			Efficiency											
072 = 6 Tons (1 circuit) 091 = 7.5 Tons (1 circuit) 120 = 10 Tons (2 circuit) 180 = 15 Tons (2 circuit) 240 = 20 Tons (2 circuit)														
													Nominal Tonnage	
K = 208/230-1-60 H = 208/230-3-60 M = 460/208/230-3-60 L = 460-3-60 S = 575-3-60														
													Voltage	
A = Standard Static Standard Efficiency Motor / Standard Drive B = High (Alternate) Static Standard Efficiency Motor / High Drive (072 & 091 Only) High (Alternate) Static High A Efficiency Motor/ High Drive (120, 180, 240 Only) D = Standard Static High Efficiency Motor / Standard Drive E = High Static High Efficiency Motor / High Drive														
													Fan Motor Options	
A = Al/Cu										Indoor Coil				
A = Future Use														
0 = Single Speed Indoor Fan Motor										Fan Speed Controller				
2 = Two Speed Indoor Fan Motor Controller (VFD)														
A = Standard – Unpainted										Painted Cabinet Options				
B = Painted cabinet (Gray)														
0 = Future use												Future Use		
A = Standard														

Single phase FHS072-091 units designate standard motor and high static drive.
 All FHS072-120 with a "M" voltage designation are triple voltage; i.e., 208/230/460-3-60.
 "M" voltage is not available on 2-speed indoor fan motor option.

RGX MODEL NUMBER NOMENCLATURE

MODEL SERIES	R	G	X	0	6	0	L	D	A	B	0	A	A	A
Position Number	1	2	3	4	5	6	7	8	9	10	11	12	13	14
R = Rooftop G = Gas/Electric Type														
X = ASHRAE 90.1 Standard Efficiency														
036 = 3 Tons 048 = 4 Tons 060 = 5 Tons Nominal Cooling Capacity														
K = 208/230-1-60 H = 208/230-3-60 L = 460-3-60 S = 575-3-60 Voltage														
D = Low Heat E = Medium Heat F = High Heat L = Low Heat, Low NOx M = Medium Heat, Low NOx N = High Heat, Low NOx S = Low Heat, Stainless Steel Heat Exchanger R = Medium Heat, Stainless Steel Heat Exchanger T = High Heat, Stainless Steel Heat Exchanger Heating Capacity														
X = Standard Motor Direct Drive B = High Static Motor / Drive - Belt Drive C = Medium Static Motor / Drive - Belt Drive H = High Static Motor / Drive - Belt Drive with Hot Gas ReHeat Motor Option (Indoor Fan)														
A = None B = Economizer w/Baro-relief, OA Temp sensor E = Economizer w/Baro-relief + CO ₂ Sensor, OA Temp sensor H = Economizer w/Baro-relief, enthalpy sensor L = Economizer w/Baro-relief + CO ₂ Sensor, enthalpy sensor U = Temp Ultra Low Leak Economizer w/Baro-relief W = Enthalpy Ultra Low Leak Economizer w/Baro-relief P = 2-Position damper Outdoor Air Options / Control¹														
OA = No Options AT = Non-powered 115v C.O. 4B = Non-Fused Disconnect BR = Supply Air Smoke Detector AA = Easy Access Hinged Panels Factory Installed Options														
A = Aluminum / Copper Cond & Evap Coil B = Precoat Alum/Copper Cond with Alum / Copper Evap(3 phase only) C = E-Coated Alum/Copper Cond with Alum / Copper Evap(3 phase only) D = E-Coated Alum / Copper Cond & Evap(3 phase only) E = Copper/Copper Cond & Alum/Copper Evap(3 phase only) F = Copper/Copper Cond & Evap(3 phase only) Condenser / Evaporator Coil Configuration														
A = Economizer controls for EconoMiZerIV B = Economizer controls for EconoMiZerX Motor Type Option														

NOTE: Factory installed options are NOT available on single phase models. This includes economizers and 2 position dampers.

¹ Combinations of FIOPs are available.

RAX MODEL NUMBER NOMENCLATURE

MODEL SERIES	R	A	X	0	6	0	L	O	A	B	0	A	A	A
Position Number	1	2	3	4	5	6	7	8	9	10	11	12	13	14
R = Rooftop														
A = Air Conditioning	Type													
X = ASHRAE 90.1 Standard	Efficiency													
036 = 3 Tons 048 = 4 Tons 060 = 5 Tons	Nominal Cooling Capacity													
K = 208/230-1-60 H = 208/230-3-60 L = 460-3-60 S = 575-3-60	Voltage													
O = No Heat	Heating Capacity													
X = Standard Motor Direct Drive B = High Static Motor / Drive - Belt Drive C = Medium Static Motor / Drive - Belt Drive H = High Static Motor / Drive - Belt Drive with Hot Gas ReHeat	Motor Option (Indoor Fan)													
A = None B = Economizer w/Baro-relief, OA Temp sensor E = Economizer w/Baro-relief + CO ₂ Sensor, OA Temp sensor H = Economizer w/Baro-relief, enthalpy sensor L = Economizer w/Baro-relief + CO ₂ Sensor, enthalpy sensor U = Temp Ultra Low Leak Economizer w/Baro-relief W = Enthalpy Ultra Low Leak Economizer w/Baro-relief P = 2-Position damper	Outdoor Air Options / Control ¹													
0A = No Options AT = Non-powered 115v C.O. 4B = Non-Fused Disconnect BR = Supply Air Smoke Detector AA = Easy Access Hinged Panels	Factory Installed Options													
A = Aluminum / Copper Cond & Evap Coil B = Precoat Alum/Copper Cond with Alum / Copper Evap (3 phase only) C = E-Coated Alum/Copper Cond with Alum / Copper Evap (3 phase only) D = E-Coated Alum / Copper Cond & Evap (3 phase only) E = Copper/Copper Cond & Alum/Copper Evap (3 phase only) F = Copper/Copper Cond & Evap (3 phase only)	Condenser / Evaporator Coil Configuration													
A = Economizer controls for EconoMiZer IV B = Economizer controls for EconoMiZer X	Motor Type Option													

NOTE: Factory installed options are NOT available on single phase models. This includes economizers and 2 position dampers.

¹ Combinations of FIOPs are available.

RHX MODEL NUMBER NOMENCLATURE

MODEL SERIES	R	H	X	0	6	0	L	O	A	B	0	A	A	A
Position Number	1	2	3	4	5	6	7	8	9	10	11	12	13	14
R = Rooftop														
H = Heat Pump	Type													
X = ASHRAE 62 Standard	Efficiency													
036 = 3 Tons 048 = 4 Tons 060 = 5 Tons	Nominal Cooling Capacity													
K = 208/230-1-60 H = 208/230-3-60 L = 460-3-60 S = 575-3-60	Voltage													
O = No Heat	Heating Capacity													
X = Standard Motor Direct Drive B = High Static Motor / Drive – Belt Drive C = Medium Static Motor / Drive – Belt Drive H = High Static Motor / Drive – Belt Drive with Hot Gas ReHeat	Motor Option (Indoor Fan)													
A = None B = Economizer w/Baro-relief, OA Temp sensor E = Economizer w/Baro-relief + CO ₂ Sensor, OA Temp sensor H = Economizer w/Baro-relief, enthalpy sensor L = Economizer w/Baro-relief + CO ₂ Sensor, enthalpy sensor U = Temp Ultra Low Leak Economizer w/Baro-relief W = Enthalpy Ultra Low Leak Economizer w/Baro-relief P = 2-Position damper	Outdoor Air Options / Control ¹													
0A = No Options AT = Non-Powered 115v C.O 4B = Non-Fused Disconnect BR = Supply Air Smoke Detector AA = Easy Access Hinged Panels	Factory Installed Options													
A = Aluminum / Copper Cond & Evap Coil B = Precoat Alum/Copper Cond with Alum / Copper Evap (3 phase only) C = E-Coated Alum/Copper Cond with Alum / Copper Evap (3 phase only) D = E-Coated Alum / Copper Cond & Evap (3 phase only) E = Copper/Copper Cond & Alum/Copper Evap (3 phase only) F = Copper/Copper Cond & Evap (3 phase only)	Condenser / Evaporator Coil Configuration													
A = Economizer controls for EconoMiZer IV B = Economizer controls for EconoMiZer X	Motor Type Option													

NOTE: Factory installed options are NOT available on single phase models. This includes economizers and 2 position dampers.

¹Combinations of FIOPs are available.

RGS 072-180 MODEL NUMBER NOMENCLATURE

MODEL SERIES	R	G	S	0	9	0	H	D	A	A	0	A	A	A
Position Number	1	2	3	4	5	6	7	8	9	10	11	12	13	14
R = Rooftop G = Gas/Electric Type S = Standard DOE/ASHRAE 90.1 Efficiency Efficiency 072 = 72,000 BTUH = 6 Tons (1 circuit/one stage cooling) 089 = 90,000 BTUH = 7.5 Tons (1 circuit/two stage cooling) 090 = 90,000 BTUH = 7.5 Tons (2 compressor) 100 = 102,000 BTUH = 8.5 Tons (1 circuit/two stage cooling) 102 = 102,000 BTUH = 8.5 Tons (2 compressor) 119 = 120,000 BTUH = 10 Tons (1 circuit/two stage cooling) 120 = 120,000 BTUH = 10 Tons (2 compressor) 150 = 150,000 BTUH = 12.5 Tons (2 compressor) 180 = 180,000 BTUH = 15 Tons (2 compressor) Nominal Cooling Capacity H = 208/230-3-60 L = 460-3-60 S = 575-3-60 Voltage D = Low Heat, Aluminum Heat Exchanger E = Medium Heat, Aluminum Heat Exchanger F = High Heat, Aluminum Heat Exchanger S = Low Heat, Stainless Steel Heat Exchanger R = Med Heat, Stainless Steel Heat Exchanger T = High Heat, Stainless Steel Heat Exchanger Heating Capacity A = Standard Motor/Drive B = High Static Motor/Drive ¹ C = Medium Static Motor/Drive E = High Static - High Efficiency Motor/Drive G = High Static Motor/Drive with Hot Gas Re-Heat (RGS180 only) H = High Static Motor/Drive with Hot Gas Re-Heat (not available on 089, 100, 119 models) Motor Option A = None B = Low Leak Economizer w/Barometric relief, OA Temperature Sensor E = Low Leak Economizer w/Barometric relief and CO ₂ Sensor, OA Temperature Sensor H = Low Leak Economizer w/Barometric relief, Enthalpy Sensor L = Low Leak Economizer w/Barometric relief and CO ₂ Sensor, Enthalpy Sensor P = 2-Position Damper (non U.S. models only) U = Temperature Ultra Low Leak Economizer w/Barometric relief W = Enthalpy Ultra Low Leak Economizer w/Barometric relief Outdoor Air Options 0A = No Options AT = Non-powered 115v Convenience Outlet 4B = Non-Fused Disconnect BB = Powered Convenience Outlet BR = Supply Air Smoke Detector BP = Return Air Smoke Detector AA = Easy Access Hinged Panels Factory Installed Options² A = Aluminum/Copper Condenser and Evaporator Coil B = Precoat Alum/Cu Condenser and Alum/CU Evaporator C = E-Coated Alum/Cu Condenser and Alum/CU Evaporator D = E-Coated Alum/Cu Condenser and Evaporator E = Cu/Cu Condenser and Alum/Cu Evaporator F = Copper/Copper Condenser and Evaporator Standard Condenser/Evaporator Coil Configuration A = Single-Speed Indoor Fan Motor, for W7212 controls B = Single-Speed Indoor Fan Motor, for W7220 controls T = Two-Speed Indoor Motor Controller (VFD) - Standard on U.S. models Indoor Fan Motor														

¹ Not available for RGS089 units.

² Combinations of FIOPS are available. Contact your representative for details.

RGS 210-336 MODEL NUMBER NOMENCLATURE

MODEL SERIES	R	G	S	2	1	0	H	D	A	B	0	A	A	A
Position Number	1	2	3	4	5	6	7	8	9	10	11	12	13	14
R = Rooftop														
G = Gas/Electric Type														
S = Standard ASHRAE 90.1-2010 Efficiency Efficiency														
210 = 210,000 = 17.5 Tons Dedicated Vertical SA/RA (SA = Supply Air, RA = Return Air) 240 = 240,000 = 20 Tons Dedicated Vertical SA/RA 300 = 300,000 = 25 Tons Dedicated Vertical SA/RA 336 = 330,000 = 27.5 Tons Dedicated Vertical SA/RA Nominal Cooling Capacity														
H = 208/230-3-60 L = 460-3-60 S = 575-3-60 Voltage														
D = Low Heat E = Medium Heat F = High Heat S = Low Heat, Stainless Steel Heat Exchanger R = Medium Heat, Stainless Steel Heat Exchanger T = High Heat, Stainless Steel Heat Exchanger Heating Capacity														
A = Standard Static Option (all sizes, with 1-speed and 2-speed indoor fan motor) B = High Static High Efficiency Option (all sizes, with 2-speed indoor fan motor) C = Medium Static Option (17.5 ton, with 1-speed indoor fan motor, all sizes with 2-speed indoor fan motor) E = High Static High Efficiency Option (all sizes, with 1-speed indoor fan motor) F = Medium Static High Efficiency Option (20, 25, 27.5 ton, with 1-speed indoor fan motor) G = High Static Motor with Hot Gas Re-heat (17.5, 20, and 25, with 1-speed indoor fan motor) H = High Static Motor with Hot Gas Re-heat (17.5, 20, and 25, with 2-speed indoor fan motor) Motor Option														
A = None B = Economizer w/Baro-relief, OA Temp sensor E = Economizer w/Baro-relief + CO ₂ sensor, OA Temp sensor H = Economizer w/Baro-relief, Enthalpy sensor L = Economizer w/Baro-relief + CO ₂ sensor, Enthalpy sensor U = Ultra Low Leak Temp Economizer w/Baro-relief (2-speed indoor fan motor only) W = Ultra Low Leak Temp Enthalpy Economizer w/Baro-relief (2-speed indoor fan motor only) P = 2-Position damper Outdoor Air Options / Control														
0A = No Options 4B = Non-fused Disconnect AA = Hinged Access Panels AT = Non-powered 115v Convenience Outlet. BR = Supply Air Smoke Detector Other Factory Installed Options¹														
A = Alum / Cu Cond and Alum / Cu Evap B = Pre coated Alum / Cu Cond and Alum / Cu Evap C = E-coated Alum / Cu Cond and Alum / Cu Evap D = E-coated Alum / E-coated Cu Cond and Alum / Cu Evap E = Cu / Cu Cond and Alum / Cu Evap F = Cu / Cu Cond and Cu / Cu Evap Coil Factory Installed Options														
A = Standard Motor T = 2 Speed Indoor Fan VFD Controller (For 2-stage units only) Motor Type Option														

¹Combination of FIOPs are available.

SMALL PACKAGE PRODUCTS THREE PHASE

Up to 16 SEER, Up to 12.5 EER, PACKAGE GAS / ELECTRIC UNIT, 2 to 5 TONS 208/230-1-60, Single Phase 208/230-3-60, Three Phase

REFRIGERATION CIRCUIT

- Environmentally balanced R-410A refrigerant
- Copper tube/aluminum fin condenser and evaporator coils
- Tin-plated copper evaporator coil standard (single-phase only)
- Two stage scroll compressors standard on all models
- Two stage gas valve and two speed inducer motor on all models

EASY TO INSTALL AND SERVICE

- Installs easily on a rooftop or at ground level
- Easy three-panel accessibility for maintenance and installation
- Easily converts to down discharge applications
- Combination two-stage gas heating and electric cooling
- Low NOx units are designed for California installations and meet 40 ng/J NOx emissions. Can be installed in air quality management districts with a 40 ng/J NOx emissions requirement.

BUILT TO LAST

- Hail guard (3/8" spacing) wire grilles standard
- Induced-draft combustion and venting
- High efficiency ECM blower motor on all models
- High efficiency two-speed inducer motor on single phase models
- Pre-painted steel cabinet
- Direct spark ignition
- Stainless Steel tubular heat exchanger standard
- Vertical condenser fan discharge
- Full perimeter steel base rails
- Crankcase heaters on select models
- High and low pressure switches provide added reliability for the compressor
- Cabinet air leakage of 2.0% or less at .5 in. W.C. when tested in accordance with ASHRAE standard 193
- Models with factory installed options are identified with letters in the 11th and 12th positions in the model number
- Factory installed tin-plated copper evaporator main tubes PGR5 (GP)
- Single and 3-phase models with factory installed option for low cabinet air leakage and tin-plated copper evaporator main tubes PGR5 (GC)

LIMITED WARRANTY*

- 1 Phase PGR5 Models
- 5 year No Hassle Replacement™ limited warranty
- 10 year parts limited warranty (including compressor and coils) and lifetime heat exchanger limited warranty with timely registration
- 5 year parts limited warranty and 20 year heat exchanger limited warranty if not registered within 90 days of original installation.
- 3 Phase PGR5 Models
- 10 year heat exchanger limited warranty
- 5 year compressor limited warranty
- 1 year parts limited warranty

* See warranty certificate for complete details and restrictions



Use of the AHRI Certified TM Mark indicates a manufacturer's participation in the program. For verification of certification for individual products, go to www.ahridirectory.org.



As an Energy Star Partner, International Comfort Products has determined that this product meets the ENERGY STAR® guidelines for energy efficiency.



UNIT PERFORMANCE DATA									
Model Number	COOLING			HEATING			Unit Dimensions Height x Width x Depth inches (mm)	Operating Weight lbs (kg)	
	Net Capacity BTU/h High Stage	SEER	EER	Input BTU/h High/Low	Efficiency AFUE %			1Ø	3Ø
					1Ø	3Ø			
PGR524040K**◆	23,000	15.0	12.0	40,000/26,000	81.0	-	44-1/8 x 47 x 31-7/16 (1121 x 1194 x 799)	342	-
PGR524060K**◆	23,000	15.0	12.0	60,000/39,000	81.0	-		(155)	-
PGR530040‡**◆	29,000	15.0	12.0	40,000/26,000	81.0	78.0		376	376
PGR530060‡**◆	29,000	15.0	12.0	60,000/39,000	81.0	78.6	(170)	(170)	
PGR536060‡**◆	35,400	16.0	12.5	60,000/39,000	81.0	78.6	44-3/4 x 47 x 42-15/16 (1137 x 1194 x 1091)	463 (210)	463 (210)
PGR536090‡**◆	35,400	16.0	12.5	90,000/58,500	81.0	79.2			
PGR542060‡**◆	42,000	16.0	12.5	60,000/39,000	81.0	78.6			
PGR542090‡**◆	42,000	16.0	12.5	90,000/58,500	81.0	79.2	50-3/4 x 47 x 42-15/16 (1289 x 1194 x 1091)	481 (218)	481 (218)
PGR548090‡**◆	47,500	16.0	12.3	90,000/58,500	81.0	79.2			
PGR548115‡**◆	47,500	16.0	12.3	115,000/75,000	81.0	80.1			
PGR548130K**◆	47,500	16.0	12.3	127,000/84,500	81.0	-	52-3/4 x 47 x 42-15/16 (1340 x 1194 x 1091)	509 (231)	509 (231)
PGR548130H**◆	47,500	16.0	12.3	130,000/84,500	-	80.0			
PGR560090‡**◆	57,000	16.0	12.3	90,000/58,500	81.0	79.2			
PGR560115‡**◆	57,000	16.0	12.3	115,000/75,000	81.0	80.1	52-3/4 x 47 x 42-15/16 (1340 x 1194 x 1091)	509 (231)	509 (231)
PGR560130K**◆	57,000	16.0	12.3	127,000/84,500	81.0	-			
PGR560130H**◆	57,000	16.0	12.3	130,000/84,500	-	80.0			

‡ K = 208/230-1-60H = 208/230-3-60

** GC = Low cabinet air leakage plus Tin-Plated Copper Evaporator Main Tubes, Stainless Steel Heat Exchanger GP = Tin-Plated Evaporator Main Tubes (single phase)

◆ 0 = Standard, 1 = Low NOx

Specifications subject to change without notice.

UP to 16 SEER, UP to 12.5 EER, PACKAGE AIR CONDITIONING UNITS, 2 – 5 TONS

208/230 Volt, 1-phase, 60 Hz

208/230 Volt, 3-phase, 60 Hz

REFRIGERATION CIRCUIT

- Environmentally balanced R-410A refrigerant
- Copper tube/aluminum fin condenser and evaporator coils
- Tin-coated copper evaporator coil standard (single-phase only)
- Enhanced dehumidification feature on high stage cooling with use of a dehumidistat
- Two stage scroll compressors standard on all models

EASY TO INSTALL AND SERVICE

- Installs easily on a rooftop or at ground level
- Easy three-panel accessibility for maintenance and installation
- Easily converts to down discharge applications

BUILT TO LAST

- Hail guard (3/8-in. spacing) wire grilles standard
- Multi-speed ECM blower motor standard on all models
- Pre-painted steel cabinet
- Vertical condenser fan discharge
- Full perimeter steel base rails
- High and low pressure switches provide added reliability for the compressor
- Cabinet air leakage of 2.0% or less at 0.5 in. W.C. when tested in accordance with ASHRAE standard 193
- Single and 3-phase models with factory installed option for low cabinet air leakage and tin-coated copper evaporator main tubes (LC)
- Single phase models with factory installed hail guard (3/8-in. spacing) wire grilles plus tin-coated copper evaporator coil (TP)
(Models with factory installed options are identified with letters in the 11th and 12th positions in the model number)

LIMITED WARRANTY*

Single Phase PAR5 Models

- 5 year No Hassle Replacement limited warranty
- 5 year parts limited warranty (including compressor and coils)
– With timely registration, an additional 5 year parts limited warranty (including compressor and coils)

3-Phase PAR5 Models

- 5 year parts limited warranty (including compressor and coils)

* For residential applications only. See warranty certificate for complete details and restrictions, including warranty coverage for other applications.



As an Energy Star® Partner, International Comfort Products has determined that this product meets the ENERGY STAR® guidelines for energy efficiency.



Use of the AHRI Certified TM Mark indicates a manufacturer's participation in the program. For verification of certification for individual products, go to www.ahridirectory.org.

UNIT PERFORMANCE DATA

Model Number	COOLING				Unit Dimensions Height x Width x Depth Inches (mm)	Operating Weight lbs / kg
	Net Capacity BTU/h High Stage	Standard CFM High / Low Stage	SEER	EER		
PAR524000K**0A	23000	800/600	15.0	12.0	44-1/8 x 46-13/16 x 31-3/16 (1121 x 1189 x 792)	327/148
PAR530000‡**0A	29000	1000/750	15.0	12.0	44-1/8 x 46-13/16 x 31-3/16 (1121 x 1189 x 792)	334/152
PAR536000‡**0A	35400	1200/900	16.0	12.5	44-3/4 x 46-13/16 x 42-15/16 (1137 x 1189 x 1091)	389/176
PAR542000‡**0A	42000	1400/1050	16.0	12.5	44-3/4 x 46-13/16 x 42-15/16 (1137 x 1189 x 1091)	392/178
PAR548000‡**0A	47500	1600/1200	16.0	12.3	50-3/4 x 46-13/16 x 42-15/16 (1269 x 1189 x 1091)	444/201
PAR560000‡**0A	57000	1750/1200	16.0	12.3	52-3/4 x 46-13/16 x 42-15/16 (1340 x 1189 x 1091)	464/211

‡ = K – 208/230–1–60, H –208/230–3–60

** = TP = Tin-coated copper coil, LC = Low Cabinet Air Leakage plus Tin Coated Copper Evaporator Main Tubes

Specifications subject to change without notice.

UP to 15.5 SEER, UP to 12.5 EER, PACKAGE HEAT PUMP UNITS, 2 - 5 TONS

208/230 Volt, 1-phase, 60 Hz

208/230 Volt, 3-phase, 60 Hz

REFRIGERATION CIRCUIT

- Environmentally balanced R-410A refrigerant
- Copper tube/aluminum fin condenser and evaporator coils
- Tin-plated copper evaporator coil standard (single-phase only)
- Dehumidification feature on high stage cooling with use of a dehumidistat
- Two stage scroll compressors standard on all models
- Advanced Dehumidification Feature – Offered as a FIOP only

EASY TO INSTALL AND SERVICE

- Installs easily on a rooftop or at ground level
- Easy three-panel accessibility for maintenance and installation
- Easily converts to down discharge applications

BUILT TO LAST

- Hail guard (3/8-in. spacing) wire grilles standard
 - Multi-speed ECM blower motor standard on all models
 - Pre-painted steel cabinet
 - Vertical condenser fan discharge
 - Full perimeter steel base rails
 - High and low pressure switches provide added reliability for the compressor
 - Cabinet air leakage of 2.0% or less at .5 in. W.C. when tested in accordance with ASHRAE standard 193 (Low cabinet air leakage FIOP models only)
- Models with factory installed options are identified with letters in the 11th and 12th positions in the model number

- Single and 3-phase models with factory installed option for low cabinet air leakage and tin-plated copper evaporator main tubes (LC)
- Single phase models with factory installed tin-plated copper evaporator main tubes (TP)

LIMITED WARRANTY*

- 5 year No Hassle Replacement limited warranty (Single-phase only)
- 5 year parts limited warranty (including compressor and coils)
 - With timely registration, an additional 5 year parts limited warranty, including compressor and coils (Single-phase only)

* For residential applications only. See warranty certificate for complete details and restrictions, including warranty coverage for other applications.



As an Energy Star® Partner, International Comfort Products has determined that this product meets the ENERGY STAR® guidelines for energy efficiency.



Use of the AHRI Certified TM Mark indicates a manufacturer's participation in the program. For verification of certification for individual products, go to www.ahridirectory.org.

UNIT PERFORMANCE DATA								
Model Number	COOLING				HSPF	COP	Unit Dimensions Height x Width x Depth Inches (mm)	Operating Weight lbs / kg
	Net Capacity BTU/h High Stage	Standard CFM High / Low Stage	SEER	EER				
PHR524000K**OB	22800	855/675	15.0	12.0	8.2	3.9	51-3/4 x 47 x 32-5/8 (1315 x 1194 x 829)	338/153
PHR530000‡**OB	29400	1000/775	15.0	12.0	8.2	3.7	51-3/4 x 47 x 32-5/8 (1315 x 1194 x 829)	384/174
PHR536000‡**OA	34000	1200/900	15.0	12.0	8.2	3.7	44-3/4 x 48-1/4 x 44-3/16 (1237 x 1226 x 1122)	413/187
PHR542000‡**OA	42000	1400/1050	15.0	12.0	8.2	3.6	50-3/4 x 48-1/4 x 44-3/16 (1289 x 1226 x 1122)	444/201
PHR548000‡**OA	47500	1600/1200	15.5	12.5	8.2	3.7	48-3/4 x 48-1/4 x 44-3/16 (1238 x 1226 x 1122)	447/203
PHR560000‡**OA	57000	1750/1400	15.0	12.0	8.5	3.5	54-3/4 x 48-1/4 x 44-3/16 (1391 x 1226 x 1122)	503/228

‡ K = 208/230-1-60, H = 208/230-3-60

** 00 = Standard (3-phase), AD = Advanced Dehumidification with Tin-Plated Copper Evaporator Main Tubes,

TP = Tin-Plated Evaporator Main Tubes plus Stainless Steel Heat Exchanger (single phase) LC = Low cabinet air leakage plus Tin-Plated Copper Evaporator Main Tubes,

Specifications subject to change without notice.

Up to 14.5 SEER PACKAGE DUAL FUEL HEAT PUMP

208/230-3-60, Three Phase, 3-5 Nominal Tons REFRIGERATION CIRCUIT

- Environmentally balanced R-410A refrigerant
- Scroll compressor standard on all models
- Copper tube/aluminum fin condenser and evaporator coils
- Dehumidification mode (airflow reduction) on all models

EASY TO INSTALL AND SERVICE

- Installs easily on a rooftop or at ground level
- Easy three-panel accessibility for maintenance and installation
- Easily converts to down discharge applications
- Combination gas heating, heat pump heating, and electric cooling
- Low NOx units are designed for California installations and meet 40 ng/J NOx emissions. Can be installed in air quality management districts with a 40 ng/J NOx emissions requirement.

BUILT TO LAST

- Induced-draft combustion and venting
- Pre-painted steel cabinet
- Direct spark ignition
- High efficiency ECM indoor blower motor on all models
- Vertical condenser fan discharge
- Full perimeter steel base rails
- High and low pressure switches provide added reliability for the compressor
- Aluminumized steel tubular heat exchanger and 2-in. spacing wire grilles on PDD4 models (00), Stainless Steel tubular heat exchanger and hail guard (3/8-in. spacing) wire grilles on PDS4 models
- PDS4 single phase models with factory installed tin-plated copper evaporator main tubes (GP)
PDS4 3-phase models with standard evaporator tubes (GP)
Models with factory installed options are identified with letters in the 11th and 12th positions in the model number

LIMITED WARRANTY*

- 1 Phase PDS4 "G" Models
 - 3 year No Hassle Replacement™ limited warranty
 - 10 year parts limited warranty (including compressor and coils) and lifetime heat exchanger limited warranty with timely registration
 - 5 year parts limited warranty and 20 year heat exchanger limited warranty if not registered within 90 days of original installation
 - 1 Phase PDD4 "G" Models
 - 15 year heat exchanger limited warranty
 - 10 year parts limited warranty (including compressor and coils) with timely registration
 - 5 year parts limited warranty if not registered within 90 days of original installation.
 - 3 Phase PDS4, PDD4 "E" Models
 - 10 year heat exchanger limited warranty
 - 5 year compressor limited warranty
 - 1 year parts limited warranty
- * See warranty certificate for complete details and restrictions



Use of the AHRI Certified TM Mark indicates a manufacturer's participation in the program. For verification of certification for individual products, go to www.ahridirectory.org.



UNIT PERFORMANCE DATA

Aluminumized Steel Heat Exchanger	Stainless Steel Heat Exchanger	COOLING			HEAT PUMP HEATING		GAS HEATING			Unit Dimensions Height x Width x Depth in (mm)	Operating Weight lbs (kg)
		Capacity BTU/h	SEER	EER	Capacity BTU/h	HSPF	Input BTU/h	Efficiency AFUE % 1Ø 3Ø			
PDD424040K00*#	PDS424040KG^*#	23,000	14.5	12.0	22,600	8.0	40,000	81.0	-	47-3/4 x 48-3/16 x 32-5/8 (1213 x 1224 x 829)	311 (141)
PDD424060K00*#	PDS424060KG^*#	23,000	14.5	12.0	22,600	8.0	60,000	81.0	-		311 (141)
PDD430040K00*#	PDS430040KG^*#	28,600	14.0	11.5	28,400	8.0	40,000	81.0	-	51-3/4 x 48-3/16 x 32-5/8 (1315 x 1224 x 829)	351 (159)
PDD430060K00*#	PDS430060KG^*#	28,600	14.0	11.5	28,400	8.0	60,000	81.0	-		351 (159)
PDD436060+00*#	PDS436060+G^*#	34,200	14.0	11.5	34,400	8.0	60,000	81.0	78.5	48-3/4 x 48-3/16 x 44-1/8 (1238 x 1224 x 1122)	387 (176)
PDD436090+00*#	PDS436090+G^*#	34,200	14.0	11.5	34,400	8.0	90,000	81.0	80.4		387 (176)
PDD442060+00*#	PDS442060+G^*#	41,000	14.0	11.5	40,000	8.0	60,000	81.0	78.5	54-3/4 x 48-3/16 x 44-1/8 (1391 x 1224 x 1122)	435 (197)
PDD442090+00*#	PDS442090+G^*#	41,000	14.0	11.5	40,000	8.0	90,000	81.0	80.4		435 (197)
PDD448090+00*#	PDS448090+G^*#	48,000	14.0	12.0	46,000	8.0	90,000	81.0	80.4		456 (207)
PDD448115+00*#	PDS448115+G^*#	48,000	14.0	12.0	46,000	8.0	115,000	81.0	80.3		456 (207)
PDD448130K00*#	PDS448130KG^*#	48,000	14.0	12.0	46,000	8.0	127,000	81.0	-		456 (207)
PDD448130H00*#	PDS448130HG^*#	48,000	14.0	12.0	46,000	8.0	130,000	-	78.9		456 (207)
PDD460090+00*#	PDS460090+G^*#	57,500	14.0	11.5	57,500	8.0	90,000	81.0	80.4		487 (221)
PDD460115+00*#	PDS460115+G^*#	57,500	14.0	11.5	57,500	8.0	115,000	81.0	80.3		487 (221)
PDD460130K00*#	PDS460130KG^*#	57,500	14.0	11.5	57,500	8.0	127,000	81.0	-		487 (221)
PDD460130H00*#	PDS460130HG^*#	57,500	14.0	11.5	57,500	8.0	130,000	-	78.9		487 (221)

‡ K = 208/230-1-60, H = 208/230-3-60

* 0 = Standard, 1 = Low NOx

00 = No Options

^ P = Tin-Plated Evaporator Main Tubes plus Stainless Steel Heat Exchanger (single-phase)

C = Low Cabinet Air Leakage plus Tin-Plated Evaporator Main Tubes plus Stainless Steel Heat Exchanger

G = 1-phase series, E = 3-phase series

Specifications subject to change without notice.

Up to 14.0 SEER, 11.5 EER, PACKAGE GAS / ELECTRIC UNIT 208/230-3-60 & 460-3-60, Three Phase, 3 - 5 Nominal Tons

REFRIGERATION CIRCUIT

- Environmentally balanced R-410A refrigerant
- Copper tube/aluminum fin condenser and evaporator coils
- Dehumidification mode (airflow reduction) on all models

EASY TO INSTALL AND SERVICE

- Installs easily on a rooftop or at ground level
- Easy three-panel accessibility for maintenance and installation
- Easily converts to down discharge applications
- Combination gas heating and electric cooling
- Low NOx units available

BUILT TO LAST

- Induced-draft combustion and venting
- Pre-painted steel cabinet
- Direct spark ignition
- High efficiency ECM indoor blower motor on all models
- Vertical condenser fan discharge
- Full perimeter steel base rails
- High pressure switch provides added reliability for the compressor
- Cabinet air leakage of 2.0% or less at 0.5 in. W.C. when tested in accordance with ASHRAE standard 193 (Low cabinet air leakage FLOP models only) Models with factory installed options are identified with letters in the 11th and 12th positions in the model number
- Aluminumized steel tubular heat exchanger and 2-in. spacing wire grilles on PGD4 models (00), Stainless Steel tubular heat exchanger and hail guard (3/8-in. spacing) wire grilles on PGS4 models
- Single phase models with factory installed tin-plated copper evaporator main tubes PGD4 (TP), PGS4 (GP), 3-phase models with standard evaporator tubes PGS4 (GP)
- Single and 3-phase models with factory installed option for low cabinet air leakage and tin-plated copper evaporator main tubes PGD4 (LC), PGS4 (GC)

LIMITED WARRANTY*

- 1 Phase PGS4 "G" Models
 - 3 year No Hassle Replacement™ limited warranty
 - 10 year parts limited warranty (including compressor and coils) with timely registration
 - 5 year parts limited warranty and 20 year heat exchanger limited warranty if not registered within 90 days of original installation.
 - 1-Phase PGD4 "G" Models
 - 15 year heat exchanger limited warranty
 - 10 year parts limited warranty (including compressor and coils) with timely registration
 - 5 year parts limited warranty and 15 year heat exchanger limited warranty if not registered within 90 days of original installation.
 - 3-Phase PGS4, PGD4 "E" Models
 - 10 year heat exchanger limited warranty
 - 5 year compressor limited warranty
 - 1 year parts limited warranty
- * See warranty certificate for complete details and restrictions



PGD4 – Representative model only, some models may vary in appearance.



Use of the AHRI Certified TM Mark indicates a manufacturer's participation in the program. For verification of certification for individual products, go to www.ahridirectory.org.

UNIT PERFORMANCE DATA								
Stainless Steel Heat Exchanger	COOLING			HEATING			Unit Dimensions Height x Width x Depth in (mm)	Operating Weight lbs (kg)
	Capacity BTU/h	SEER	EER	Input BTU/h	Efficiency			
					AFUE %	1Ø		
PGS424040K^^#	23,600	14.0	11.5	40,000	81.0	-	43-3/4 x 48-3/16 x 32-5/8 (1111 x 1224 x 829)	304 (138)
PGS424060K^^#	23,600	14.0	11.5	60,000	81.0	-		304 (138)
PGS430040K^^#	28,600	14.0	11.5	40,000	81.0	-	45-3/4 x 48-3/16 x 32-5/8 (1162 x 1224 x 829)	320 (145)
PGS430060K^^#	28,600	14.0	11.5	60,000	81.0	-		320 (145)
PGS436060‡^^#	34,800	14.0	11.5	60,000	81.0	80.0	51-3/4 x 48-3/16 x 32-5/8 (1315 x 1224 x 829)	349 (158)
PGS436090‡^^#	34,800	14.0	11.5	90,000	81.0	79.3		349 (158)
PGS442060‡^^#	40,000	14.0	11.5	60,000	81.0	78.5	44-3/4 x 48-3/16 x 44-1/8 (1137 x 1224 x 1123)	413 (187)
PGS442090‡^^#	40,000	14.0	11.5	90,000	81.0	80.4		413 (187)
PGS448090‡^^#	48,000	14.0	11.5	90,000	81.0	80.4	52-3/4 x 48-3/16 x 44-1/8 (1340 x 1224 x 1123)	438 (199)
PGS448115‡^^#	48,000	14.0	11.5	115,000	81.0	80.3		438 (199)
PGS448130‡^^#	48,000	14.0	11.5	127,000	81.0	-		438 (199)
PGS460090‡^^#	56,000	14.0	11.5	90,000	81.0	80.4	54-3/4 x 48-3/16 x 44-1/8 (1391 x 1224 x 1123)	455 (206)
PGS460115‡^^#	56,000	14.0	11.5	115,000	81.0	80.3		455 (206)
PGS460130‡^^#	56,000	14.0	11.5	127,000	81.0	-		455 (206)

‡ K = 208/230-1-60, H = 208/230-3-60, L = 460-3-60

** PGD4 - 00 = Standard, LC = Low cabinet air leakage plus Tin-Plated Copper Evaporator Main Tubes, TP=Tin-Plated Copper Evaporator Main Tubes (single phase)
PGS4 - GC = Low cabinet air leakage plus Tin-Plated Copper Evaporator Main Tubes plus Stainless Steel Heat Exchanger, GP (1-phase) or GP (3-phase) = Tin-Plated Evaporator Main Tubes plus Stainless Steel Heat Exchanger

^ 0 = Standard, 1 = Low Nox

G = 1-phase series, E = 3-phase series

Specifications subject to change without notice.

Up to 14.0 SEER, 11.5 EER, PACKAGE GAS / ELECTRIC UNIT

208/230-3-60 & 460-3-60, Three Phase, 3 - 5 Nominal Tons

REFRIGERATION CIRCUIT

- Environmentally balanced R-410A refrigerant
- Copper tube/aluminum fin condenser and evaporator coils
- Dehumidification mode (airflow reduction) on all models

EASY TO INSTALL AND SERVICE

- Installs easily on a rooftop or at ground level
- Easy three-panel accessibility for maintenance and installation
- Easily converts to down discharge applications
- Combination gas heating and electric cooling
- Low NOx units available

BUILT TO LAST

- Induced-draft combustion and venting
- Pre-painted steel cabinet
- Direct spark ignition
- High efficiency ECM indoor blower motor on all models
- Vertical condenser fan discharge
- Full perimeter steel base rails
- High pressure switch provides added reliability for the compressor
- Cabinet air leakage of 2.0% or less at 0.5 in. W.C. when tested in accordance with ASHRAE standard 193 (Low cabinet air leakage F10P models only) Models with factory installed options are identified with letters in the 11th and 12th positions in the model number
- Aluminumized steel tubular heat exchanger and 2-in. spacing wire grilles on PGD4 models (00), Stainless Steel tubular heat exchanger and hail guard (3/8-in. spacing) wire grilles on PGS4 models
- Single phase models with factory installed tin-plated copper evaporator main tubes PGD4 (TP), PGS4 (GP), 3-phase models with standard evaporator tubes PGS4 (GP)
- Single and 3-phase models with factory installed option for low cabinet air leakage and tin-plated copper evaporator main tubes PGD4 (LC), PGS4 (GC)

LIMITED WARRANTY*

- 1-Phase PGS4 "G" Models
 - 3 year No Hassle Replacement™ limited warranty
 - 10 year parts limited warranty (including compressor and coils) with timely registration
 - 5 year parts limited warranty and 20 year heat exchanger limited warranty if not registered within 90 days of original installation.
 - 1-Phase PGD4 "G" Models
 - 15 year heat exchanger limited warranty
 - 10 year parts limited warranty (including compressor and coils) with timely registration
 - 5 year parts limited warranty and 15 year heat exchanger limited warranty if not registered within 90 days of original installation.
 - 3-Phase PGS4, PGD4 "E" Models
 - 10 year heat exchanger limited warranty
 - 5 year compressor limited warranty
 - 1 year parts limited warranty
- * See warranty certificate for complete details and restrictions



PGD4 – Representative model only, some models may vary in appearance.



Use of the AHRI Certified TM Mark indicates a manufacturer's participation in the program. For verification of certification for individual products, go to www.ahridirectory.org.

UNIT PERFORMANCE DATA

Aluminumized Steel Heat Exchanger	COOLING			HEATING			Unit Dimensions Height x Width x Depth in (mm)	Operating Weight lbs (kg)
	Capacity BTU/h	SEER	EER	Input BTU/h	Efficiency AFUE %			
					1Ø	3Ø		
PGD424040K***#	23,600	14.0	11.5	40,000	81.0	-	43 ³ / ₄ x 48 ³ / ₁₆ x 32 ⁵ / ₈	304 (138)
PGD424060K***#	23,600	14.0	11.5	60,000	81.0	-	(1111 x 1224 x 829)	304 (138)
PGD430040K***#	28,600	14.0	11.5	40,000	81.0	-	45 ³ / ₄ x 48 ³ / ₁₆ x 32 ⁵ / ₈	320 (145)
PGD430060K***#	28,600	14.0	11.5	60,000	81.0	-	(1162 x 1224 x 829)	320 (145)
PGD436060±***#	34,800	14.0	11.5	60,000	81.0	80.0	51 ³ / ₄ x 48 ³ / ₁₆ x 32 ⁵ / ₈	349 (158)
PGD436090±***#	34,800	14.0	11.5	90,000	81.0	79.3	(1315 x 1224 x 829)	349 (158)
PGD442060±***#	40,000	14.0	11.5	60,000	81.0	78.5	44 ³ / ₄ x 48 ³ / ₁₆ x 44 ¹ / ₈	413 (187)
PGD442090±***#	40,000	14.0	11.5	90,000	81.0	80.4	(1137 x 1224 x 1123)	413 (187)
PGD448090±***#	48,000	14.0	11.5	90,000	81.0	80.4		438 (199)
PGD448115±***#	48,000	14.0	11.5	115,000	81.0	80.3	52 ³ / ₄ x 48 ³ / ₁₆ x 44 ¹ / ₈	438 (199)
PGD448130±***#	48,000	14.0	11.5	127,000	81.0	-	(1340 x 1224 x 1123)	438 (199)
PGD460090±***#	56,000	14.0	11.5	90,000	81.0	80.4		455 (206)
PGD460115±***#	56,000	14.0	11.5	115,000	81.0	80.3	54 ³ / ₄ x 48 ³ / ₁₆ x 44 ¹ / ₈	455 (206)
PGD460130±***#	56,000	14.0	11.5	127,000	81.0	-	(1391 x 1224 x 1123)	455 (206)

± K = 208/230-1-60, H = 208/230-3-60, L = 460-3-60

** PGD4 - 00 = Standard, LC = Low cabinet air leakage plus Tin-Plated Copper Evaporator Main Tubes, TP = Tin-Plated Copper Evaporator Main Tubes (single phase)

PGS4 - GC = Low cabinet air leakage plus Tin-Plated Copper Evaporator Main Tubes plus Stainless Steel Heat Exchanger, GP(1-phase) or GP (3-phase) = Tin-Plated Evaporator Main Tubes plus Stainless Steel Heat Exchanger

^ 0 = Standard, 1 = Low Nox

G = 1-phase series, E = 3-phase series

Specifications subject to change without notice.

Up to 14.5 SEER PACKAGE DUAL FUEL HEAT PUMP

208/230-3-60, Three Phase, 3-5 Nominal Tons

REFRIGERATION CIRCUIT

- Environmentally balanced R-410A refrigerant
- Scroll compressor standard on all models
- Copper tube/aluminum fin condenser and evaporator coils
- Dehumidification mode (airflow reduction) on all models

EASY TO INSTALL AND SERVICE

- Installs easily on a rooftop or at ground level
- Easy three-panel accessibility for maintenance and installation
- Easily converts to down discharge applications
- Combination gas heating, heat pump heating, and electric cooling
- Low NOx units are designed for California installations and meet 40 ng/J NOx emissions. Can be installed in air quality management districts with a 40 ng/J NOx emissions requirement.

BUILT TO LAST

- Induced-draft combustion and venting
- Pre-painted steel cabinet
- Direct spark ignition
- High efficiency ECM indoor blower motor on all models
- Vertical condenser fan discharge
- Full perimeter steel base rails
- High and low pressure switches provide added reliability for the compressor
- Aluminumized steel tubular heat exchanger and 2-in. spacing wire grilles on PDD4 models (00), Stainless Steel tubular heat exchanger and hail guard (3/8-in. spacing) wire grilles on PDS4 models
- PDS4 single phase models with factory installed tin-plated copper evaporator main tubes (GP)
- PDS4 3-phase models with standard evaporator tubes (GP)

Models with factory installed options are identified with letters in the 11th and 12th positions in the model number

LIMITED WARRANTY*

- 1 Phase PDS4 "G" Models
- 3 year No Hassle Replacement™ limited warranty
- 10 year parts limited warranty (including compressor and coils) and lifetime heat exchanger limited warranty with timely registration
- 5 year parts limited warranty and 20 year heat exchanger limited warranty if not registered within 90 days of original installation

1 Phase PDD4 "G" Models

- 15 year heat exchanger limited warranty
- 10 year parts limited warranty (including compressor and coils) with timely registration
- 5 year parts limited warranty if not registered within 90 days of original installation.

3 Phase PDS4, PDD4 "E" Models

- 10 year heat exchanger limited warranty
- 5 year compressor limited warranty
- 1 year parts limited warranty

* See warranty certificate for complete details and restrictions



Use of the AHRI Certified TM Mark indicates a manufacturer's participation in the program. For verification of certification for individual products, go to www.ahridirectory.org.



UNIT PERFORMANCE DATA

Aluminized Steel Heat Exchanger	COOLING			HEAT PUMP HEATING		GAS HEATING			Unit Dimensions Height x Width x Depth in (mm)	Operating Weight lbs (kg)
	Capacity BTU/h	SEER	EER	Capacity BTU/h	HSPF	Input BTU/h	Efficiency AFUE %			
							1Ø	3Ø		
PDD424040K00*#	23,000	14.5	12.0	22,600	8.0	40,000	81.0	-	47-3/4 x 48-3/16 x 32-5/8 (1213 x 1224 x 829)	311 (141)
PDD424060K00*#	23,000	14.5	12.0	22,600	8.0	60,000	81.0	-		311 (141)
PDD430040K00*#	28,600	14.0	11.5	28,400	8.0	40,000	81.0	-	51-3/4 x 48-3/16 x 32-5/8 (1315 x 1224 x 829)	351 (159)
PDD430060K00*#	28,600	14.0	11.5	28,400	8.0	60,000	81.0	-		351 (159)
PDD436060+00*#	34,200	14.0	11.5	34,400	8.0	60,000	81.0	78.5	48-3/4 x 48-3/16 x 44-1/8 (1238 x 1224 x 1122)	387 (176)
PDD436090+00*#	34,200	14.0	11.5	34,400	8.0	90,000	81.0	80.4		387 (176)
PDD442060+00*#	41,000	14.0	11.5	40,000	8.0	60,000	81.0	78.5	54-3/4 x 48-3/16 x 44-1/8 (1391 x 1224 x 1122)	435 (197)
PDD442090+00*#	41,000	14.0	11.5	40,000	8.0	90,000	81.0	80.4		435 (197)
PDD448090+00*#	48,000	14.0	12.0	46,000	8.0	90,000	81.0	80.4		456 (207)
PDD448115+00*#	48,000	14.0	12.0	46,000	8.0	115,000	81.0	80.3		456 (207)
PDD448130K00*#	48,000	14.0	12.0	46,000	8.0	127,000	81.0	-		456 (207)
PDD448130H00*#	48,000	14.0	12.0	46,000	8.0	130,000	-	78.9		456 (207)
PDD460090+00*#	57,500	14.0	11.5	57,500	8.0	90,000	81.0	80.4		487 (221)
PDD460115+00*#	57,500	14.0	11.5	57,500	8.0	115,000	81.0	80.3		487 (221)
PDD460130K00*#	57,500	14.0	11.5	57,500	8.0	127,000	81.0	-		487 (221)
PDD460130H00*#	57,500	14.0	11.5	57,500	8.0	130,000	-	78.9		487 (221)

‡ K = 208/230-1-60, H = 208/230-3-60

* 0 = Standard, 1 = Low NOx

00 = No Options

^ P = Tin-Plated Evaporator Main Tubes plus Stainless Steel Heat Exchanger (single-phase)

C = Low Cabinet Air Leakage plus Tin-Plated Evaporator Main Tubes plus Stainless Steel Heat Exchanger

G = 1-phase series, E = 3-phase series

Specifications subject to change without notice.

Up to 14.0 SEER, 11.5 EER PACKAGE AIR CONDITIONER 208/230-3-60 & 460-3-60 Three Phase, 3-5 Nominal Tons

REFRIGERATION CIRCUIT

- Environmentally balanced R-410A refrigerant
- Copper tube/aluminum fin condenser and evaporator coils
- Dehumidification mode (airflow reduction) on all models

EASY TO INSTALL AND SERVICE

- Installs easily on a rooftop or at ground level
- Easy three-panel accessibility for maintenance and installation
- Easily converts to down discharge applications

BUILT TO LAST

- High efficiency ECM indoor blower motor on all models
- Vertical condenser fan discharge
- Full perimeter steel base rails
- High pressure switch provides added reliability for the compressor
- 2-in. spacing wire grilles standard on single and 3-phase models (00)
- Cabinet air leakage of 2.0% or less at 0.5 in. W.C. when tested in accordance with ASHRAE standard 193 (Low cabinet air leakage F10P models only)
Models with factory installed options are identified with letters in the 11th and 12th positions in the model number
- Single and 3-phase models with factory installed option for low cabinet air leakage and tin-coated copper evaporator main tubes (LC)
- Single phase models with factory installed hail guard (3/8-in. spacing) wire grilles plus tin-coated copper evaporator coil (TP)

LIMITED WARRANTY*

- 1 Phase PAD4 "E/F" Models
 - 3 year No Hassle Replacement™ limited warranty for tin-coated "TP" models
 - 10 year parts limited warranty (including compressor and coils) with timely registration
 - 5 year parts limited warranty if not registered within 90 days of original installation
- 3 Phase PAD4 "E" Models
 - 5 year compressor limited warranty
 - 1 year parts limited warranty

* See warranty certificate for complete details and restrictions



Use of the AHRI Certified TM Mark indicates a manufacturer's participation in the program. For verification of certification for individual products, go to www.ahridirectory.org.



UNIT PERFORMANCE DATA					
Model Number	COOLING			Unit Dimensions Height x Width x Depth in (mm)	Operating Weight lbs (kg)
	Capacity BTU/h	SEER	EER		
208/230-1-60					
PAD424000†**0E	23,000	14.0	11.5	43 ³ / ₄ x 48 ³ / ₁₆ x 32 ⁵ / ₈ (1111 x 1224 x 829)	304 (138)
PAD430000†**0F	28,600	14.0	11.5	45 ³ / ₄ x 48 ³ / ₁₆ x 32 ⁵ / ₈ (1162 x 1224 x 829)	320 (145)
PAD436000†**0E	34,800	14.0	11.5	51 ³ / ₄ x 48 ³ / ₁₆ x 32 ⁵ / ₈ (1315 x 1224 x 829)	349 (158)
PAD442000†**0E	40,000	14.0	11.5	44 ³ / ₄ x 48 ¹ / ₄ x 44 ³ / ₁₆ (1137 x 1226 x 1123)	413 (187)
PAD448000†**0E	46,000	14.0	11.5	52 ³ / ₄ x 48 ¹ / ₄ x 44 ³ / ₁₆ (1340 x 1226 x 1123)	438 (199)
PAD460000†**0E	56,000	14.0	11.5	54 ³ / ₄ x 48 ¹ / ₄ x 44 ³ / ₁₆ (1391 x 1226 x 1123)	455 (206)
208/230-3-60					
PAD436000†**0E	34,800	14.0	11.5	51 ³ / ₄ x 48 ³ / ₁₆ x 32 ⁵ / ₈ (1315 x 1224 x 829)	349 (158)
PAD442000†**0E	41,000	14.0	11.5	44 ³ / ₄ x 48 ¹ / ₄ x 44 ³ / ₁₆ (1137 x 1226 x 1123)	413 (187)
PAD448000†**0E	47,000	14.0	11.5	52 ³ / ₄ x 48 ¹ / ₄ x 44 ³ / ₁₆ (1340 x 1226 x 1123)	438 (199)
PAD460000†**0E	57,000	14.0	11.5	54 ³ / ₄ x 48 ¹ / ₄ x 44 ³ / ₁₆ (1391 x 1226 x 1123)	455 (206)
460-3-60					
PAD436000†**0E	34,200	14.0	11.5	51 ³ / ₄ x 48 ³ / ₁₆ x 32 ⁵ / ₈ (1315 x 1224 x 829)	349 (158)
PAD442000†**0E	41,000	14.0	11.5	44 ³ / ₄ x 48 ¹ / ₄ x 44 ³ / ₁₆ (1137 x 1226 x 1123)	413 (187)
PAD448000†**0E	47,000	14.0	11.5	52 ³ / ₄ x 48 ¹ / ₄ x 44 ³ / ₁₆ (1340 x 1226 x 1123)	438 (199)
PAD460000†**0E	57,000	14.0	11.5	54 ³ / ₄ x 48 ¹ / ₄ x 44 ³ / ₁₆ (1391 x 1226 x 1123)	455 (206)

† K = 208-230/1/60, H = 208-230/3/60, L = 460/3/60

** 00 = No Options, TP = Tin-Plated Evaporator Main Tubes (Single Phase 24-60 sizes), LC = Low Cabinet Air Leakage plus Tin-Plated Copper Evaporator Main Tubes

Specifications subject to change without notice.

Up to 14.5 SEER, 12 EER, 8.0 HSPF, PACKAGE HEAT PUMP, 2 to 5 TONS 208/230-1-60 Single Phase

REFRIGERATION CIRCUIT

- Environmentally balanced R-410A refrigerant
- Copper tube/aluminum fin condenser and evaporator coils
- Scroll compressor standard on all models
- Short-cycling protection for the compressor is built into the defrost control board
- Dehumidification mode (airflow reduction) on all models

EASY TO INSTALL AND SERVICE

- Installs easily on a rooftop or at ground level
- Easy three-panel accessibility for maintenance and installation
- Easily converts to down discharge applications
- Combination electric heating and cooling

BUILT TO LAST

- Direct drive high efficiency ECM blower motor on all models
- Pre-painted steel cabinet
- Vertical condenser fan discharge
- Full perimeter steel base rails
- High and low pressure switches provide added reliability for the compressor
- Cabinet air leakage of 2.0% or less at .5 in. W.C. when tested in accordance with ASHRAE standard 193 (Low cabinet air leakage FIOP models only)
- Models with factory installed options are identified with letters in the 14th and 15th positions in the model number
- Hail guard (3/8-in. spacing) wire grilles standard on single phase models with optional factory installed tin-plated copper evaporator coil (TP). All other models have 2-in. spacing wire grilles including 3-phase models
- Single and 3-phase models with factory installed option for low cabinet air leakage and tin-plated copper evaporator main tubes PHD4 (LC)

LIMITED WARRANTY*

- 1 Phase PHD4 “F” Models
- 3 year No Hassle Replacement™ limited warranty for tin-plated “TP” models
- 10 year parts limited warranty (including compressor and coils) with timely registration
- 5 year parts limited warranty if not registered within 90 days of original installation
- 3 Phase PHD4 “F” Models
- 5 year compressor limited warranty
- 1 year parts limited warranty
- * See warranty certificate for details and restrictions



Use of the AHRI Certified TM Mark indicates a manufacturer's participation in the program. For verification of certification for individual products, go to www.ahrirectory.org.

UNIT PERFORMANCE DATA							
Model Number	COOLING			HEATING		Unit Dimensions Height x Width x Depth in (mm)	Operating Weight lbs (kg)
	Capacity BTU/h	SEER	EER	Capacity BTU/h	HSPF		
208/230-1-60							
PHD424000K**0F	23,000	14.5	12.0	22,600	8.0	47 ³ / ₄ x 48 ³ / ₁₆ x 32 ⁵ / ₈ (1213 x 1224 x 829)	311 (141)
PHD430000K**0F	28,600	14.0	11.5	28,400	8.0	51 ³ / ₄ x 48 ³ / ₁₆ x 32 ⁵ / ₈ (1315 x 1224 x 829)	351 (159)
PHD436000+**0F	34,200	14.0	11.5	34,400	8.0	48 ³ / ₄ x 48 ³ / ₁₆ x 44 ³ / ₁₆ (1238 x 1224 x 1122)	387 (176)
PHD442000†**0F	41,000	14.0	11.5	40,000	8.0	54 ³ / ₄ x 48 ³ / ₁₆ x 44 ³ / ₁₆ (1391 x 1224 x 1122)	435 (197)
PHD448000†**0F	48,000	14.0	12.0	46,000	8.0	54 ³ / ₄ x 48 ³ / ₁₆ x 44 ³ / ₁₆ (1391 x 1224 x 1122)	456 (207)
PHD460000†**0F	57,500	14.0	11.5	57,500	8.0	48 ³ / ₄ x 48 ³ / ₁₆ x 44 ³ / ₁₆ (1238 x 1224 x 1122)	487 (221)
208/230-3-60							
PHD436000†**0F	34,200	14.0	11.5	34,400	8.0	48 ³ / ₄ x 48 ³ / ₁₆ x 44 ³ / ₁₆ (1238 x 1224 x 1122)	387 (176)
PHD442000†**0F	41,000	14.0	11.5	40,000	8.0	54 ³ / ₄ x 48 ³ / ₁₆ x 44 ³ / ₁₆ (1391 x 1224 x 1122)	435 (197)
PHD448000†**0F	48,000	14.0	12.0	46,000	8.0	54 ³ / ₄ x 48 ³ / ₁₆ x 44 ³ / ₁₆ (1391 x 1224 x 1122)	456 (207)
PHD460000†**0F	57,500	14.0	11.5	57,500	8.0	48 ³ / ₄ x 48 ³ / ₁₆ x 44 ³ / ₁₆ (1238 x 1224 x 1122)	487 (221)
460-3-60							
PHD436000+**0F	34,200	14.0	11.5	34,400	8.0	48 ³ / ₄ x 48 ³ / ₁₆ x 44 ³ / ₁₆ (1238 x 1224 x 1122)	387 (176)
PHD442000+**0F	41,000	14.0	11.5	40,000	8.0	54 ³ / ₄ x 48 ³ / ₁₆ x 44 ³ / ₁₆ (1391 x 1224 x 1122)	435 (197)
PHD448000†**0F	48,000	14.0	12.0	46,000	8.0	54 ³ / ₄ x 48 ³ / ₁₆ x 44 ³ / ₁₆ (1391 x 1224 x 1122)	456 (207)
PHD460000†**0F	57,500	14.0	11.5	57,500	8.0	48 ³ / ₄ x 48 ³ / ₁₆ x 44 ³ / ₁₆ (1238 x 1224 x 1122)	487 (221)

† K = 208/230-1-60, H = 208/230-3-60, L = 460-3-60

** 00 = No Options, TP = Tin-Plated Evaporator Main Tubes (Single Stage), LC = Low Cabinet Air Leakage plus Tin-Plated Copper Evaporator Main Tubes

Specifications subject to change without notice.

EFFICIENT 13 SEER AIR CONDITIONER ENVIRONMENTALLY BALANCED R-410A REFRIGERANT 1-1/2 THRU 5 TONS SPLIT SYSTEM

208/230 Volt, 1-phase, 60 Hz

REFRIGERATION CIRCUIT

- Scroll compressors on all models
- Filter-Drier supplied with every unit for field installation
- Copper tube / aluminum fin coil

EASY TO INSTALL AND SERVICE

- Easy Access service valves on all models
- External high and low refrigerant service ports
- Only two screws to access control panel
- Factory charged with R-410A refrigerant

BUILT TO LAST

- Baked-on powder coat finish over galvanized steel
- Post-painted (black) coil fins
- Coated, weather-resistant cabinet screws
- Coated inlet grille with 2-in. (51mm) spacing standard, alternate models available with 3/8-in. (10mm) grille spacing for extra protection (hail guard)

LIMITED WARRANTY*

- 5 year compressor limited warranty
- 5 year parts limited warranty (including compressor and coil)
 - With timely registration, an additional 5 year parts limited warranty (including compressor and coil)

* For owner occupied, residential applications only. See warranty certificate for complete details and restrictions, including warranty coverage for other applications.



Use of the AHRI Certified TM Mark indicates a manufacturer's participation in the program. For verification of certification for individual products, go to www.ahridirectory.org.



Model Number	Size (tons)	Nominal BTU/hr	Min. Circuit Ampacity	Max. Fuse or Breaker	Operating Dimensions height x width/depth in. (mm)	Ship / Operating Weight lbs. (kg)
N4A318*KF	1-1/2	18,000	11.8	20	25-5/16 x 23-1/8 (643 x 587)	130 / 107 (59 / 49)
N4A324*KG	2	24,000	14.3	25	25-5/16 x 23-1/8 (643 x 587)	127 / 107 (58 / 49)
N4A330*KG	2-1/2	30,000	16.6	25	28-11/16 x 25-3/4 (729 x 654)	149 / 126 (68 / 57)
N4A336*KF	3	36,000	18.1	30	25-5/16 x 31-3/16 (642 x 792)	151 / 134 (68 / 61)
N4A342*KN	3-1/2	42,000	23.5	40	32-5/16 x 31-3/16 (821 x 792)	218 / 190 (99 / 86)
N4A348*KG	4	48,000	24.3	40	35-1/2 x 31-3/16 (901 x 792)	205 / 175 (93 / 79)
N4A360*KN	5	60,000	29.0	50	28-11/16 x 31-3/16 (729 x 792)	232 / 199 (106 / 91)

* **A** = 2" (51mm) spacing inlet grille or
G = 3/8" (10mm) spacing inlet grille

Specifications subject to change without notice.

14 SEER HORIZONTAL DISCHARGE AIR CONDITIONER FOR USE WITH DUCTED INDOOR UNIT ENVIRONMENTALLY SOUND R-410A REFRIGERANT

1-1/2 THRU 5 TONS, 208/230 Volt, 1-Phase

3 THRU 5 TONS, 208/230 Volt, 3-Phase

3 THRU 5 TONS, 460 Volt, 3-Phase

REFRIGERATION CIRCUIT

- 14 SEER/11.7 – 12.2 EER
- Scroll compressor
- Factory-supplied filter-drier
- High pressure switch
- Line lengths up to 250 feet (76.2 m)

EASY TO INSTALL AND SERVICE

- Small footprint
- Easy access service valves on all models
- Factory charged with R-410A refrigerant

BUILT TO LAST

- Low ambient operation (down to -0°F/-17.8°C)
- Ball-Bearing Fan Motor

WARRANTY*

- 5 year parts limited warranty (including compressor and coil)
 - With timely registration, an additional 5 year parts limited warranty (including compressor and coil)

* For residential applications only. See warranty certificate for complete details and restrictions, including warranty coverage for other applications.



Use of the AHRi Certified TM Mark indicates a manufacturer's participation in the program. For verification of certification for individual products, go to www.ahrirectory.org.



Model Number	Size (tons)	Nominal Btu/hr	Min Circuit Ampacity	Max Fuse or Breaker	Operating Dimensions height x width x depth inches (mm)	Operating/Ship Weight lbs. (kg)
208/230-1-60						
NH4A418AKA	1½	18,000	11.8	20	31-1/8 x 36-15/16 x 14-9/16 (790 x 938 x 370)	146/166 (66/75)
NH4A424AKA	2	24,000	14.1	25	31-1/8 x 36-15/16 x 14-9/16 (790 x 938 x 370)	148/168 (67/76)
NH4A430AKA	2½	30,000	18.3	30	37-1/8 x 44-1/2 x 17-1/16 (943 x 1130 x 433)	183/213 (83/97)
NH4A436AKA	3	36,000	18.8	30	37-1/8 x 44-1/2 x 17-1/16 (943 x 1130 x 433)	184/214 (84/97)
NH4A448AKA	4	48,000	24.3	40	37-1/8 x 44-1/2 x 17-1/16 (943 x 1130 x 433)	213/243 (97/110)
NH4A460AKA	5	60,000	31.1	50	43-1/8 x 44-1/2 x 17-1/16 (1095 x 1130 x 433)	245/275 (111/125)
208/230-3-60						
NH4A436AHA	3	36,000	12.5	20	37-1/8 x 44-1/2 x 17-1/16 (943 x 1130 x 433)	184/214 (84/97)
NH4A448AHA	4	48,000	18.3	30	37-1/8 x 44-1/2 x 17-1/16 (943 x 1130 x 433)	213/243 (97/110)
NH4A460AHA	5	60,000	21.4	35	43-1/8 x 44-1/2 x 17-1/16 (1095 x 1130 x 433)	245/275 (111/125)
460-3-60						
NH4A436ALA	3	36,000	7.6	15	37-1/8 x 44-1/2 x 17-1/16 (943 x 1130 x 433)	184/214 (84/97)
NH4A448ALA	4	48,000	8.7	15	37-1/8 x 44-1/2 x 17-1/16 (943 x 1130 x 433)	213/243 (97/110)
NH4A460ALA	5	60,000	9.7	15	43-1/8 x 44-1/2 x 17-1/16 (1095 x 1130 x 433)	245/275 (111/125)

Specifications subject to change without notice.

COMMERCIAL SPLIT SYSTEMS CONDENSING UNITS R-410A, 6 to 20 TONS

BUILT TO LAST, EASY TO INSTALL AND SERVICE

- Single stage cooling capacity control on all 072 to 150 models
 - Terminal board facilitating simple safety circuit troubleshooting and simplified control box
 - Outdoor temperature cooling operation range up to 125°F (52°C) and down to 35°F (2°C)
 - All models utilize copper tube / aluminum plate fin coils
 - Brass suction and liquid line service valves
 - Full perimeter base rail with built-in rigging adapters and fork truck slots
 - Pre-painted exterior panels and primer-coated interior panels tested to 500 hours salt spray protection
 - Compressors mounted on independent vibration isolators
 - High capacity filter drier is supplied for each circuit. Field installation is required
 - Comfort Alert™ Diagnostic Board
 - LED Go-N-Go and fault code
 - Built in time guard anti-short cycle
 - 3-phase fault protection
 - Fault code retention logic
 - Low volt compressor contactor protector
 - All units have high and low pressure switches
 - Direct drive permanently lubricated condenser fan motors
 - UL and UL, Canada apply to standard units; 575 volt units UL, Canada only
- LIMITED WARRANTY**
- 5 Year compressor limited warranty
 - 1 Year parts limited warranty



CAS072-121

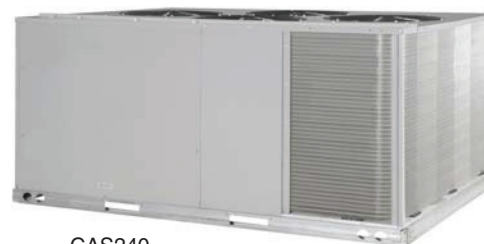

CAS240



Use of the AHRI Certified TM Mark indicates a manufacturer's participation in the program. For verification of certification for individual products, go to www.ahridirectory.org.



UNIT PERFORMANCE DATA ¹ – Single Circuit						
Model Number	COOLING			Total Power (kW)	Unit Dimensions H x W x L Inches [mm]	Ship Weight lb. / kg
	Nominal Capacity Ton	Net Capacity BTUH	EER			
CAS072*AA0A00A	6	71,000	11.5	6.2	42-3/8 x 59-3/8 x 45-7/8 [1077 x 1508 x 1164]	389 / 176
CAS091*AA0A00A	7.5	92,000	11.2	8.2	42-3/8 x 59-3/8 x 45-7/8 [1077 x 1508 x 1164]	391 / 177
CAS121*AA0A00A	10	117,000	11.2	10.4	50-3/8 x 59-3/8 x 45-7/8 [1279 x 1507 x 1164]	490 / 222
CAS151*AA0A00A	12.5	148,000	11.0	13.5	50-3/8 x 59-3/8 x 45-7/8 [1279 x 1507 x 1164]	598 / 271
CAS181*AA0A00A	15	184,000	11.2	16.4	50-3/8 x 86-3/8 x 45-1/8 [1279 x 2193 x 1148]	731 / 322
CAS241*AA0A00A	20	240,000	11.0	21.8	50-3/8 x 86-3/8 x 67-1/8 [1279 x 2193 x 1704]	978 / 444
UNIT PERFORMANCE DATA ¹ – Dual Circuit						
CAS120*DA0A00A	10	117,000	11.2	10.4	50-3/8 x 59-3/8 x 45-7/8 [1279 x 1507 x 1164]	516 / 234
CAS150*DA0A00A	12.5	148,000	11.0	13.5	50-3/8 x 59-3/8 x 45-7/8 [1279 x 1507 x 1164]	654 / 297
CAS180*DA0A00A	15	184,000	11.2	16.4	50-3/8 x 86-3/8 x 45-1/8 [1279 x 2193 x 1148]	731 / 322
CAS240*DA0A00A	20	240,000	11.0	21.8	50-3/8 x 86-3/8 x 67-1/8 [1279 x 2193 x 1704]	978 / 444

* – Indicates Unit voltage: H = 208/230-3-60, L = 460-3-60, S = 575-3-60

¹ – Above ratings are with matching size air handling unit

Specifications subject to change without notice.

14 SEER HEAT PUMP ENVIRONMENTALLY BALANCED R-410A REFRIGERANT

1½ THRU 5 TONS SPLIT SYSTEM
208/230 Volt 1-phase, 208/230 Volt 3-phase,
460 Volt 3-phase; 60 Hz

REFRIGERATION CIRCUIT

- Scroll compressors on all models
- Suction line accumulator factory installed
- Bi-flow filter-drier included for field installation
- Integrated solid state control with Time-Temperature Defrost
- High and Low pressure switches
- Copper tube / aluminum fin coil

EASY TO INSTALL AND SERVICE

- Easy Access service valves on all models
- External high and low refrigerant service ports
- Only two screws to access control panel
- Factory charged with R-410A refrigerant

BUILT TO LAST

- Baked-on powder coat finish over galvanized steel
- Post-painted (black) coil fins
- Coated, weather-resistant cabinet screws
- Coated inlet grille with 3/8-in. (10mm) grille spacing for extra protection

LIMITED WARRANTY*

- 5 year parts limited warranty (including compressor and coil)
 - With timely registration, an additional 5 year parts limited warranty (including compressor and coil)

* For residential applications only. See warranty certificate for complete details and restrictions, including warranty coverage for other applications.



Use of the AHRI Certified TM Mark indicates a manufacturer's participation in the program. For verification of certification for individual products, go to www.ahridirectory.org.



Model Number	Size (tons)	Nominal Btu/hr	Min. Circuit Ampacity	Max. Fuse or Breaker	Operating Dimensions length x width x height inches (mm)	Operating/Ship Weight lbs. (kg)
N4H418GKG	1½	18,000	11.8	20	23-1/8 x 23-1/8 x 35-1/2 (587 x 587 x 902)	136 / 166 (61 / 75)
N4H424GKG	2	24,000	14.2	25	25-3/4 x 25-3/4 x 35-1/2 (654 x 654 x 902)	144 / 175 (65 / 79)
N4H430GKG	2½	30,000	16.9	30	31-3/16 x 31-3/16 x 32-1/16 (792 x 792 x 815)	158 / 180 (72 / 82)
N4H436G*G	3	36,000	19.5	30	31-3/16 x 31-3/16 x 38-7/8 (792 x 792 x 988)	170 / 201 (77 / 91)
N4H442GKG	3½	42,000	24.0	40	31-3/16 x 31-3/16 x 38-7/8 (792 x 792 x 988)	201 / 235 (91 / 107)
N4H448G*G	4	48,000	25.2	40	31-3/16 x 31-3/16 x 28-11/16 (792 x 792 x 729)	197 / 232 (89 / 105)
N4H460G*G	5	60,000	32.0	50	31-3/16 x 31-3/16 x 32-1/16 (792 x 792 x 815)	212 / 248 (96 / 113)

* K = 208/230V Single-Phase; H = 208/230V Three-Phase; L = 460V Three-Phase

Specifications subject to change without notice.

COMMERCIAL SPLIT SYSTEMS HEAT PUMP UNITS R-410A, 6-20 TONS

BUILT TO LAST, EASY TO INSTALL AND SERVICE

- Single stage cooling capacity control on 072 to 121 models, two stage cooling capacity control on 180 to 240 models
- All models utilize round copper tube, aluminum plate fin condenser coils (RTPF)
- Brass suction and liquid line service valves
- Fully hermetic scroll compressors with crankcase heater and suction line accumulators
- Compressors include overload protection and vibration isolation for further enhancement of quiet operation
- Comfort Alert™ Diagnostic Board
 - LED Go-N-Go and fault code
 - Built in time guard anti-short cycle
 - Phase protection
 - Fault code retention logic
 - Low volt compressor contactor protector
- Full perimeter base rail with built-in rigging adapters and fork truck slots
- Pre-painted exterior panels and primer-coated interior panels tested to 500 hours salt spray protection
- Filter drier standard with each unit (shipped for field installation)
- Direct drive permanently lubricated condenser fan motors
- Newly designed terminal board facilitates simple safety circuit troubleshooting and simplified control box arrangement
- All units have high pressure and loss of charge protection
- Outdoor temperature cooling operation range up to 125°F (52°C) and down to 35°F (2°C)
- Models with optional low ambient control provide cooling operation down to -20°F (-29°C)
- UL and UL, Canada apply to standard units; 575-volt units UL, Canada only on 072 to 121 models
- High Capacity filter drier on each refrigerant circuit



CHS072-121



CHS240



Use of the AHRI Certified TM Mark indicates a manufacturer's participation in the program. For verification of certification for individual products, go to www.ahrirectory.org.



LIMITED WARRANTY

- 5 Year compressor limited warranty
- 1 Year parts limited warranty

UNIT PERFORMANCE DATA ¹ – Single Circuit							
Model Number	Cooling Circuits	COOLING			Total Power (KW)	Unit Dimensions H x W x L Inches [mm]	Ship Weight lb. / kg
		Nominal Capacity Ton	Net Capacity BTUH	EER			
CHS072*AA0A00A	1	6	70,000	11.0	6.4	42-3/8 x 59-3/8 x 45-7/8 [1077 x 1508 x 1164]	444 / 201
CHS091*AA0A00A	1	7.5	89,000	11.0	8.1	42-3/8 x 59-3/8 x 45-7/8 [1077 x 1508 x 1164]	483 / 219
CHS121*AA0A00A	1	10	112,000	11.0	10.2	50-3/8 x 59-3/8 x 45-7/8 [1279 x 1507 x 1164]	575 / 261
UNIT PERFORMANCE DATA ¹ – Dual Circuit							
CHS180*DA0A00A	2	15	178,000	10.6	16.8	50-3/8 x 86-3/8 x 45-1/8 [1279 x 2193 x 1148]	768 / 348
CHS240*DA0A00A	2	20	222,000	10.7	20.8	50-3/8 x 86-3/8 x 67-1/8 [1279 x 2193 x 1704]	1015 / 460

* – Indicates Unit voltage: H = 208/230-3-60, L = 460-3-60, S = 575-3-60

¹ – Above ratings are with matching size air handling unit

Specifications subject to change without notice.

DIRECT EXPANSION COMMERCIAL PACKAGED AIR HANDLING UNITS, 6 - 25 TONS BUILT TO LAST, EASY TO INSTALL AND SERVICE

- Multi-position design for horizontal or vertical installation without modification.
- Two sloped condensate pans on each unit for horizontal or vertical applications.
- Standard sloped drain pans and cleanable insulation treated with Environmental Protection Agency (EPA) registered antimicrobial agent improves indoor air quality.
- High-static design meets a wider range of applications than competitive packaged air handler lines
- Ultra low leak economizer accessory provides ventilation air and “free” cooling with built in Fault Detection and Diagnostic (FDD) capabilities
- Single refrigerant circuit on 072 and 091 sizes. Dual refrigerant circuit on 120-300 sizes. Dual circuit can be field modified for use on single circuit condensers.
- Cooling coils with mechanically bonded fins provide peak heat transfer.
- Optional 2-speed indoor fan with VFD controller
- Standard factory-installed thermo-static expansion valve (TXV) with removable power element.
- Easy maintenance – removal of single panel allows access to virtually all components.
- Die-formed galvanized steel casings provide durability and structural integrity. Optional paint is available.
- 24-volt terminal block for control wiring connection.
- Hot water coil, steam coil, and electric heat accessories are available.

WARRANTY

- 1 Year parts limited warranty

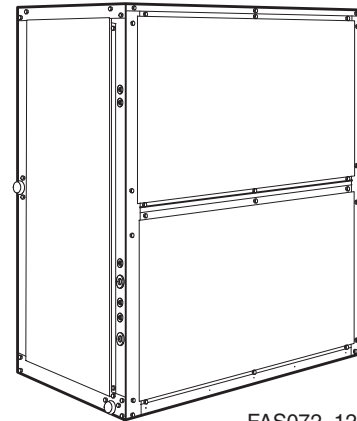

FAS072-120

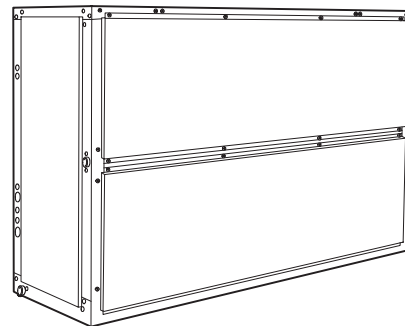

FAS150-300



Use of the AHRI Certified TM Mark indicates a manufacturer's participation in the program. For verification of certification for individual products, go to www.ahridirectory.org.

UNIT PERFORMANCE DATA

UNIT	Nominal Tons	Number of Circuits	Unit Dimensions H x W x L Inches [mm]	Unit Weight lb. [kg]
FAS072*AAA0A0A	6	1	56-1/16 x 49 x 28-3/16 [1424 x 1244 x 714]	399 [181]
FAS091*AAA0A0A	7 1/2	1	56-1/16 x 49 x 28-3/16 [1424 x 1244 x 714]	404 [183]
FAS120*AAA0A0A	10	2	56-1/16 x 49 x 28-3/16 [1424 x 1244 x 714]	425 [193]
FAS150*AAA0A0A	12 1/2	2	56-1/16 x 89 x 28-3/16 [1424 x 2261 x 714]	695 [315]
FAS180*AAA0A0A	15	2	56-1/16 x 89 x 28-3/16 [1424 x 2261 x 714]	713 [323]
FAS240*AAA0A0A	20	2	56-1/16 x 89 x 28-3/16 [1424 x 2261 x 714]	730 [331]
FAS300*AAA0A0A	25	2	65-9/16 x 100-1/2 x 32-5/8 [1665 x 2553 x 829]	1050 [477]

* Indicates Unit voltage: K = 208/230-1-60, H = 208/230-3-60, M = 208/230/460-3-60, L = 460-3-60, S = 575-3-60

NOTE: BASE MODEL NUMBERS LISTED. SEE MODEL NOMENCLATURE LISTING FOR ADDITIONAL OPTIONS

Specifications subject to change without notice.

COMMERCIAL PACKAGED HEAT PUMP AIR HANDLER UNITS, 6 – 25 TONS BUILT TO LAST, EASY TO INSTALL AND SERVICE

- Multi-position design for horizontal or vertical installation without modification
- Two sloped condensate pans on each unit for horizontal or vertical applications
- Standard sloped drain pans and cleanable insulation treated with Environmental Protection Agency (EPA) registered antimicrobial agent improves indoor air quality
- High-static design meets a wide range of applications than competitive package air handler lines
- Economizer accessory provides ventilations air and “free” cooling
- Single refrigerant circuit on 072 and 091 sizes. Dual refrigerant circuit on 120 to 240 sizes. Dual circuit can be field modified for use on single circuit condensers
- Single blower on 072 to 120 sizes, dual blower on FHS180 & 240 sizes
- Optional 2–speed indoor fan with VFD controller 072 to 240 ton sizes
- High efficiency copper tube / aluminum coils
- Standard factory-installed thermo-static expansion valve (TXV) with removable power element
- Easy maintenance – removal of single panel allows access to virtually all components
- Die-formed galvanized steel casings provide durability and structural integrity. Optional paint is available
- 24-volt terminal block for control wiring connection.
- Hot water coil, steam coil, and electric heat accessories are available.

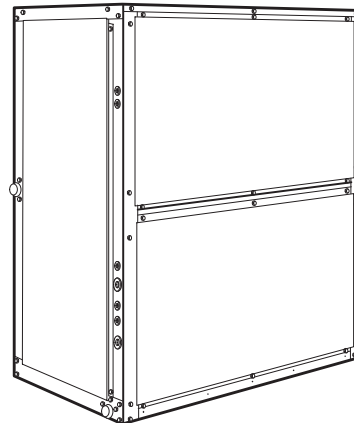

WARRANTY

- 1 Year parts limited warranty

UNIT PERFORMANCE DATA				
UNIT	Nominal Tons	Number of Circuits	Unit Dimensions H x W x L Inches [mm]	Unit Weight lb. [kg]
FHS072*AAA0A0A	6	1	56-1/16 x 49 x 28-3/16 [1424 x 1244 x 714]	381 [173]
FHS091*AAA0A0A	7 1/2	1	56-1/16 x 49 x 28-3/16 [1424 x 1244 x 714]	385 [175]
FHS120*AAA0A0A	10	2	56-1/16 x 49 x 28-3/16 [1424 x 1244 x 714]	427 [194]
FHS180*AAA0A0A	15	2	56-1/16 x 89 x 28-3/16 [1424 x 2261 x 714]	713 [323]
FHS240*AAA0A0A	20	2	56-1/16 x 89 x 283/16 [1424 x 2261 x 714]	720 [327]

* Indicates Unit voltage: K = 208/230–1–60, M = 208/230/460–3–60, H = 208/230–3–60, L = 460–3–60, S = 575–3–60

NOTE: BASE MODEL NUMBERS LISTED. SEE MODEL NOMENCLATURE LISTING FOR ADDITIONAL OPTIONS

Specifications subject to change without notice.

**COMMERCIAL RTU
3-27.5 TON**

SINGLE PACKAGE ROOFTOP UNITS WITH X-VANE™ FAN TECHNOLOGY: GAS HEATING/ELECTRIC COOLING (RGV) AND ELECTRIC COOLING/OPTIONAL ELECTRIC HEAT (RAV) 3 – 6 TON

The new 3 to 6 Ton RGV/RAV series rooftop units (RTU) with X-Vane™ Fan Technology provides value added benefits never seen in this type of equipment before. New major design features include:

- Patent pending, the industry's first beltless direct-drive vane axial fan for rooftop units with electric commutated variable speed motor.
- Reliable fixed speed scroll compressor on 3-5 ton sizes and 2 stage scroll technology on 6 ton sizes.
- Upgraded unit control board with intuitive indoor fan adjustment.
- Reliable copper tube / aluminum fin condenser coil with $\frac{5}{16}$ -in. tubing to help reduce refrigerant charge versus prior designs.
- New outdoor fan system with rugged, lightweight high impact composite fan blade.



RGV/RAV036-072

X-Vane™ Fan

Installation ease

All RGV/RAV units are field convertible to horizontal air flow, which makes it easy to adjust to unexpected job site complications. RGV/RAV rooftop units up to 6 tons are specifically designed to fit on our existing roof curbs dating back to 1989 for worry-free original fit. Also, our large control box gives you room to work and room to mount accessory controls. Intuitive controls make setting up the required fan speed simple and accurate. Access to the blower section is no longer needed with the new design.

Easy to maintain

With the new Vane Axial fan and direct drive ECM motor, there is no longer a need to adjust belts or pulleys as in past designs. This frees up maintenance and installation time.

Easy access handles provide quick and easy access to all normally serviced components. Our “no-strip” screw system has superior holding power and guides screws into position while preventing the screw from stripping the unit's metal.

Sloped, corrosion resistant composite drain pan sheds water and won't rust.

RGV units are designed with a naturally draining heat exchanger. Unlike positive pressure heat exchangers, this does not need to be periodically, manually drained. This saves labor and maintenance expense.

Easy to use

The newly re-designed Unit Control Board puts all connections and troubleshooting points in one convenient place. Most low voltage connections are made to the same board for easy access. Setting up the fan is made simple by an intuitive switch and rotary dial arrangement. RGV/RAV rooftops have high and low pressure switches, a filter drier, and 2-in. filters standard.

X-Vane Fan Technology

Direct drive X-Vane Fan Technology indoor fan system uses vane axial fan design and electrically commutated motors. This new Vane Axial design over past belt drive systems has 75% fewer moving parts, uses up to 40% less energy and has no fan belts, blower bearings, or shaft.

Design features include:

- Single-stage units deliver SEERs up to 14.0 and EERs up to 11.8. Two-stage units deliver IEERs up to 15.2 and EERs up to 11.2.
- All models are capable of either vertical or horizontal airflow.
- RGV/RAV rooftop units (RTU) were designed by customers for customers. With “no-strip” screw collars, handled access panels, and more the unit is easy to install, easy to maintain, and easy to use. Your new 3 to 6 ton RGV/RAV rooftop unit (RTU) provides optimum comfort and control from a packaged rooftop.

RGV/RAV (continued)

UNIT PERFORMANCE DATA — Single Stage Cooling /Single Circuit

UNIT	Nom. Tons	COOLING				GAS HEATING		Unit Dimensions H x W x L	Shipping Weight lb. [kg]
		Net. Cap (Btuh)	EER	SEER	IEER w/ 2-Speed Indoor Fan Motor	Input Cap. (Btuh) Stage 2	Thermal Efficiency (%)		
RGV036* [^] DA0AAA	3	34,400	11.5	14.0	N/A	65,000 - 90,000	80 - 82	33 3/8" x 46 5/8" x 74 3/8"	522 [237]
RGV048* [^] DA0AAA	4	47,000	11.6	14.0	N/A	65,000 - 130,000	80 - 82	33 3/8" x 46 5/8" x 74 3/8"	583 [265]
RGV060* [^] DA0AAA	5	58,500	11.0	14.0	N/A	65,000 - 130,000	80 - 82	33 3/8" x 46 5/8" x 74 3/8"	596 [271]

UNIT PERFORMANCE DATA — Two Stage Cooling /Single Circuit

UNIT	Nom. Tons	COOLING				GAS HEATING		Unit Dimensions H x W x L	Shipping Weight lb. [kg]
		Net. Cap (Btuh)	EER	SEER	IEER w/ 2-Speed Indoor Fan Motor	Input Cap. (Btuh) Stage 2	Thermal Efficiency (%)		
RGV072* [^] DA0AAA	6	70,000	11.0	N/A	15.0	67,000 - 150,000	80 - 81	41 3/8" x 46 5/8" x 74 3/8"	647 [294]

UNIT PERFORMANCE DATA — Single Stage Cooling /Single Circuit

UNIT	Nom. Tons	COOLING					Unit Dimensions H x W x L	Shipping Weight lb. [kg]
		Net. Cap (Btuh)	EER	SEER	Total Power (kW)	IEER w/ 2-Speed Indoor Fan Motor		
RAV036*0DA0AAA	3	34,400	11.7	14.0	2.9	N/A	33 3/8" x 46 5/8" x 74 3/8"	477 [217]
RAV048*0DA0AAA	4	47,000	11.8	14.0	4.0	N/A	33 3/8" x 46 5/8" x 74 3/8"	538 [244]
RAV060*0DA0AAA	5	58,500	11.2	14.0	5.2	N/A	33 3/8" x 46 5/8" x 74 3/8"	551 [250]

UNIT PERFORMANCE DATA — Two Stage Cooling /Single Circuit

UNIT	Nom. Tons	COOLING					Unit Dimensions H x W x L	Shipping Weight lb. [kg]
		Net. Cap (Btuh)	EER	SEER	Total Power (kW)	IEER w/ 2-Speed Indoor Fan Motor		
RAV072*0DA0AAA	6	70,000	11.2	N/A	5.7	15.2	41 3/8" x 46 5/8" x 74 3/8"	602 [273]

* Indicates Unit voltage: K = 208/230-1-60, H = 208/230-3-60, L = 460-3-60, S = 575-3-60

[^] See model nomenclature listing for gas heating options.

NOTE: BASE MODEL NUMBERS LISTED. SEE MODEL NOMENCLATURE LISTING FOR ADDITIONAL OPTIONS

Specifications subject to change without notice.

SINGLE PACKAGE ROOFTOP UNITS WITH X-VANE™ FAN TECHNOLOGY: GAS HEATING/ELECTRIC COOLING (RGW) AND ELECTRIC COOLING/OPTIONAL ELECTRIC HEAT (RAW) 3 – 5 TON

The new 3 to 5 Ton RGW/RAW series rooftop units (RTU) with X-Vane™ Fan Technology provide value added benefits never seen in this type of equipment before. New major design features include:

- Patent pending, the industry's first beltless direct-drive vane axial fan for rooftop units with electric commutated variable speed motor.
- Reliable 2 stage scroll compressor on all sizes.
- Upgraded unit control board with intuitive indoor fan adjustment.
- Reliable copper tube / aluminum fin condenser coil with $\frac{5}{16}$ -in. tubing to help reduce refrigerant charge versus prior designs.
- New outdoor fan system with rugged, lightweight high impact composite fan blade.



RGW/RAW036-060

X-Vane™ Fan

Installation ease

All RGW/RAW units are field convertible to horizontal air flow, which makes it easy to adjust to unexpected job site complications. RGW/RAW rooftop units up to 5 tons are specifically designed to fit on our existing roof curbs dating back to 1989 for worry-free original fit. Also, our large control box gives you room to work and room to mount accessory controls. Intuitive controls make setting up the required fan speed simple and accurate. Access to the blower section is no longer needed with the new design.

Easy to maintain

With the new Vane Axial fan and direct drive ECM motor, there is no longer a need to adjust belts or pulleys as in past designs. This frees up maintenance and installation time.

Easy access handles provide quick and easy access to all normally serviced components. Our “no-strip” screw system has superior holding power and guides screws into position while preventing the screw from stripping the unit's metal.

Sloped, corrosion resistant composite drain pan sheds water and won't rust.

RGW units are designed with a naturally draining heat exchanger, unlike positive pressure heat exchangers, does not need to be periodically, manually drained. This saves labor and maintenance expense.

Easy to use

The newly re-designed Unit Control Board puts all connections and troubleshooting points in one convenient place. Most low voltage connections are made to the same board for easy access. Setting up the fan is made simple by an intuitive switch and rotary dial arrangement. RGW/RAW rooftops have high and low pressure switches, a filter drier, and 2-in. filters standard.

X-Vane Fan Technology

Direct drive X-Vane Fan Technology indoor fan system uses vane axial fan design and electrically commutated motors. This new Vane Axial design over past belt drive systems has 75% fewer moving parts, uses up to 40% less energy and has no fan belts, blower bearings and shaft.

Design features include:

- Two-stage cooling capacity control delivers SEERs up to 16.0.
- All models are capable of either vertical or horizontal airflow.
- RGW/RAW rooftop units (RTU) were designed by customers for customers. With “no-strip” screw collars, handled access panels, and more the unit is easy to install, easy to maintain, and easy to use. Your new 3 to 5 ton RGW/RAW rooftop unit (RTU) provides optimum comfort and control from a packaged rooftop.

RGV/RAV (continued)

UNIT PERFORMANCE DATA — Two Stage Cooling /Single Circuit

UNIT	Nom. Tons	COOLING			GAS HEATING		Unit Dimensions H x W x L	Shipping Weight lb. [kg]
		Net Cap. (Btuh)	EER	SEER	Input Cap. (Btuh) Stage 2	Thermal Efficiency (%)		
RGW036**^DD0AAB	3	35,200	12.0	16.0	65,000 - 90,000	80 - 82	33 3/8" x 46 5/8" x 74 3/8"	553 [251]
RGW048**^DD0AAB	4	47,000	12.0	16.0	65,000 - 130,000	80 - 82	33 3/8" x 46 5/8" x 74 3/8"	595 [270]
RGW060**^DD0AAB	5	60,000	12.0	16.0	65,000 - 130,000	80 - 82	41 3/8" x 46 5/8" x 74 3/8"	640 [291]

UNIT PERFORMANCE DATA — Two Stage Cooling /Single Circuit

UNIT	Nom. Tons	COOLING				Unit Dimensions H x W x L	Shipping Weight lb. [kg]
		Net Cap. (Btuh)	EER	SEER	Total Power (kW)		
RAW036*0DD0AAB	3	35,200	12.2	16.0	2.9	33 3/8" x 46 5/8" x 74 3/8"	508 [231]
RAW048*0DD0AAB	4	47,000	12.2	16.0	3.9	33 3/8" x 46 5/8" x 74 3/8"	550 [250]
RAW060*0DD0AAB	5	60,000	12.2	16.0	4.09	41 3/8" x 46 5/8" x 74 3/8"	595 [270]

* Indicates Unit voltage: K = 208/230-1-60, H = 208/230-3-60, L = 460-3-60, S = 575-3-60

^ See model nomenclature listing for gas heating options.

NOTE: BASE MODEL NUMBERS LISTED. SEE MODEL NOMENCLATURE LISTING FOR ADDITIONAL OPTIONS

Specifications subject to change without notice.

HIGH-EFFICIENCY PACKAGE GAS HEATING/ ELECTRIC COOLING, R-410A SINGLE PACK- AGE ROOFTOP 3 TO 12.5 TONS [1 and 3-Phase]

BUILT TO LAST, EASY TO INSTALL AND SERVICE

- R-410A HFC refrigerant
- ASHRAE 90.1-2013 compliant and ENERGY STAR* qualified
- Single-stage cooling capacity control on all 036-072 models
- Two-stage cooling capacity control on 073-150 models
- Rated in accordance with AHRI Standard 210/240 [036-060 sizes] and 340/360 [072-150 sizes]
- Designed in accordance with Underwriters' Laboratories Standard 1995
- Listed by UL and UL, Canada or ETL, ETL Canada
- Exclusive non-corrosive composite condensate pan in accordance with ASHRAE 62 Standard, sloping design; side or center drain
- Gas efficiencies up to 82%†
- Induced draft combustion
- Redundant gas valve, with 1 or 2 stages of heating
- Pre-painted exterior panels and primer-coated interior panels tested to 500 hours salt spray protection
- TXV refrigerant metering device on each circuit.
- Exclusive IGC (Integrated Gas Controller) solid-state control for on-board diagnostics with LED error code designation, burner control logic, energy saving indoor fan motor delay, and anti-cycle protection for gas heat operation
- "Low NOx" models available that meet California Air Quality Management NOx requirements and include stainless steel heat exchangers
- Cooling operating range from 35°F up to 125°F. 110 size model standard cooling operation down to 0°F [-18°C]
- Access panels with easy grip handles and no-strip screw feature
- Two-inch disposable return air filters
- Tool-less filter access door
- Belt drive evaporator-fan motor and pulley combinations available on all three-phase models
- Direct Drive x13 (5 speed/torque) motor on 036 to 060 models
- Central terminal board for simple safety circuit troubleshooting and control box arrangement
- Field convertible from vertical to horizontal airflow on all models. No special kit required on 036-120 models. Supply duct kit required for 150 size model only.
- Provisions for thru-the-bottom power entry capability single point gas and electric connections
- Full perimeter base rail with built-in rigging adapters and fork truck slots
- Scroll compressors with internal line-break overload protection
- Copper tube, aluminum fin coils
- 24-volt control circuit protected with resettable circuit breaker
- Permanently lubricated evaporator-fan motor
- Permanently lubricated, totally enclosed, shaft down condenser motors
- Low-pressure, freeze protection, and high-pressure switches
- Solid-state electronic direct spark ignition system
- Liquid line filter drier

WARRANTY

- 15 Year limited warranty on optional stainless steel heat exchanger
- 10 Year limited warranty on aluminized heat exchanger
- 5 Year compressor limited warranty
- 1 Year parts limited warranty

*ENERGY STAR is a registered trademark of the U.S. Environmental Protection Agency.

† Gas efficiencies up to 82% achieved by all units except size 150 of standard units and all sizes of low NOx units.



RGH036-060



RGH072-150



OR



Intertek



Use of the AHRI Certified TM Mark indicates a manufacturer's participation in the program. For verification of certification for individual products, go to www.ahridirectory.org.

RGH 036-150 (continued)

SINGLE STAGE COOLING (SINGLE PHASE UNITS)								
UNIT	NOM. TONS	COOLING			GAS HEATING		UNIT DIMENSIONS H x W x L in (mm)	UNIT WEIGHT lb. (kg)
		NET CAP. (Btuh)	SEER	EER	INPUT CAP. (BTUH)	THERMAL EFFICIENCY (%)		
RGH036K*†XA0AAA	3	36,000	15.0	12.50	65,000-90,000	82	33 ³ / ₈ x 46 ³ / ₄ x 74 ³ / ₈ (847 x 1187 x 1888)	505 (229)
RGH048K*†XA0AAA	4	48,500	15.6	13.00	65,000-130,000	80-82	41 ³ / ₈ x 46 ³ / ₄ x 74 ³ / ₈ (1051 x 1187 x 1888)	590 (268)
RGH060K*†XA0AAA	5	57,500	15.2	12.45	65,000-130,000	80-82	41 ³ / ₈ x 46 ³ / ₄ x 74 ³ / ₈ (1051 x 1187 x 1888)	600 (271)
SINGLE STAGE COOLING (THREE PHASE UNITS)								
UNIT	NOM. TONS	COOLING			GAS HEATING		UNIT DIMENSIONS H x W x L in (mm)	UNIT WEIGHT lb. (kg)
		NET CAP. (Btuh)	SEER	EER	INPUT CAP. (BTUH)	THERMAL EFFICIENCY (%)		
RGH036*†XA0AAA	3	36,000	15.0	12.50	72,000-115,000	81-82	33 ³ / ₈ x 46 ³ / ₄ x 74 ³ / ₈ (847 x 1187 x 1888)	505 (229)
RGH048*†XA0AAA	4	48,500	15.6	13.00	72,000-150,000	80-82	41 ³ / ₈ x 46 ³ / ₄ x 74 ³ / ₈ (1051 x 1187 x 1888)	590 (268)
RGH060*†XA0AAA	5	57,500	15.2	12.45	72,000-150,000	80-82	41 ³ / ₈ x 46 ³ / ₄ x 74 ³ / ₈ (1051 x 1187 x 1888)	600 (271)
RGH072*†XA0AAA	6	73,000	N/A	12.00	72,000-150,000	80-82	41 ¹ / ₄ x 59 ¹ / ₂ x 88 ¹ / ₈ (1048 x 1510 x 2238)	765 (347)
TWO STAGE COOLING								
UNIT	NOM. TONS	COOLING			GAS HEATING		UNIT DIMENSIONS H x W x L in (mm)	UNIT WEIGHT lb. (kg)
		NET CAP. (Btuh)	SEER	EER	INPUT CAP. (BTUH)	THERMAL EFFICIENCY (%)		
RGH073*†XA0AAA	6	72,000	N/A	12.00	72,000-150,000	80-82	41 ¹ / ₄ x 59 ¹ / ₂ x 88 ¹ / ₈ (1048 x 1510 x 2238)	765 (347)
RGH090*†XA0AAA	7.5	89,000	N/A	12.00	125,00-224,000	82	49 ³ / ₈ x 59 ¹ / ₂ x 88 ¹ / ₈ (1253 x 1510 x 2238)	925 (420)
RGH102*†XA0AAA	8.5	97,000	N/A	12.00	125,00-224,000	82	49 ³ / ₈ x 59 ¹ / ₂ x 88 ¹ / ₈ (1253 x 1510 x 2238)	925 (420)
RGH110*†XA0AAA	10	111,000	N/A	12.00	180,000-250,000	80-82	49 ³ / ₈ x 59 ¹ / ₂ x 88 ¹ / ₈ (1253 x 1510 x 2238)	1090 (495)
RGH120*†XA0AAA	10	115,000	N/A	11.50	180,000-250,000	80-82	49 ³ / ₈ x 59 ¹ / ₂ x 88 ¹ / ₈ (1253 x 1510 x 2238)	1090 (495)
RGH150*†XA0AAA	12.5	146,000	N/A	12.20	150,000-240,000	80-81	57 ³ / ₈ x 63 ³ / ₈ x 115 ⁷ / ₈ (1456 x 1609 x 2942)	1430 (649)
LOW NO _x MODELS								
UNIT	NOM. TONS	COOLING			GAS HEATING		UNIT DIMENSIONS H x W x L in (mm)	UNIT WEIGHT lb. (kg)
		NET CAP. (Btuh)	SEER	EER	INPUT CAP. (BTUH)	THERMAL EFFICIENCY (%)		
RGH036*†XA0AAA	3	36,000	15.0	12.50	60,000-90,000	81	33 ³ / ₈ x 46 ³ / ₄ x 74 ³ / ₈ (847 x 1187 x 1888)	505 (229)
RGH048*†XA0AAA	4	48,500	15.6	13.00	60,000-120,000	81	41 ³ / ₈ x 46 ³ / ₄ x 74 ³ / ₈ (1051 x 1187 x 1888)	590 (268)
RGH060*†XA0AAA	5	57,500	15.2	12.45	60,000-120,000	80-81	41 ³ / ₈ x 46 ³ / ₄ x 74 ³ / ₈ (1051 x 1187 x 1888)	602 (273)

*Indicates unit voltage (Nom. V-Ph-Hz): K=208/230-1-60, H=208/230-3-60, L = 460-3-60, S= 575-3-60.

†See model number nomenclature for gas heating options.

Specifications subject to change without notice.

RGH 181-303

HIGH-EFFICIENCY GAS HEAT/ELECTRIC COOLING PACKAGED ROOFTOP 15 TO 25 NOMINAL TONS

BUILT TO LAST, EASY TO INSTALL AND SERVICE

- One-piece, high efficiency gas heating and electric cooling with a low profile, prewired, tested, and charged at the factory
- Dedicated vertical or horizontal air flow duct configuration models. No field kits required.
- Full perimeter base rail with built-in rigging adapters and fork truck slots
- Pre-painted exterior panels and primer-coated interior panels tested to 500 hours salt spray protection
- Fully insulated cabinet
- Two-stage cooling with independent circuits and control on all models
- Redundant gas valve for two stage gas heating capacity control
- Exclusive IGC solid-state control for on-board diagnostics with LED error code designation, burner control logic and energy saving indoor fan motor delay
- High efficiency, gas heat with induced draft flue exhaust design
- Scroll compressors on all models
- All units have high and low pressure switches
- Two inch disposable fiberglass type return air filters in dedicated rack with tool-less filter access door
- Refrigerant circuits contain a liquid line filter drier to trap dirt and moisture
- Exclusive non-corrosive composite condensate pan in accordance with ASHRAE 62 Standard, sloping design; end drain
- Belt drive evaporator-fan motor and pulley combinations available to meet most applications
- Access panels with easy grip handles provide quick and easy access to the blower and blower motor, control box, and compressors.
- “No-strip” screw system has superior holding power and guides screws into position while preventing the screw from stripping the unit’s metal.
- Newly designed terminal board facilitates simple safety circuit troubleshooting and simplified control box arrangement
- Standard outdoor temperature cooling operation range up to 125°F (52°C) and down to 35°F (2°C)
- TXV metering devices on all models to precisely control refrigerant flow
- Large, laminated control wiring and power wiring drawings are affixed to unit to make troubleshooting easy
- Capable of thru-the-base or thru-the-curb gas line routing
- Single point gas and electrical connections



15 Ton



WARRANTY

- 15 Year limited warranty on optional stainless steel heat exchanger.
- 10 Year limited warranty on aluminized stainless steel heat exchanger
- 5 Year compressor limited warranty
- 1 Year parts limited warranty

Unit Performance Data — Two Stage Cooling

UNIT	DEDICATED AIRFLOW	NOMINAL TONS	COOLING		GAS HEATING		UNIT DIMENSIONS (H x W x L)	UNIT WEIGHT lb. (kg)
			Net Cap. (Btuh)	EER	Input Cap. (Btuh) Stage 2	Thermal Efficiency %		
RGH181**AA0AAA	Vertical	15	174,000	12.0	220,000-400,000	81	49 3/8 x 86 3/8 x 127 7/8	1892 (860)
RGH183**AA0AAA	Horizontal	15	174,000	11.5	220,000-400,000	81	49 3/8 x 86 3/8 x 127 7/8	1892 (860)
RGH210**AA0AAA	Vertical	17.5	202,000	12.0	220,000-400,000	81	49 3/8 x 86 3/8 x 141 1/2	2102 (956)
RGH213**AA0AAA	Horizontal	17.5	202,000	11.3	220,000-400,000	81	49 3/8 x 86 3/8 x 141 1/2	2102 (956)
RGH240**AA0AAA	Vertical	20	232,000	12.0	220,000-400,000	81	57 3/8 x 86 3/8 x 141 1/2	2247 (1021)
RGH243**AA0AAA	Horizontal	20	232,000	11.4	220,000-400,000	81	57 3/8 x 86 3/8 x 141 1/2	2247 (1021)
RGH300**AA0AAA	Vertical	25	282,000	11.2	220,000-400,000	81	57 3/8 x 86 3/8 x 157 3/4	2292 (1042)
RGH303**AA0AAA	Horizontal	25	282,000	10.5	220,000-400,000	81	57 3/8 x 86 3/8 x 157 3/4	2292 (1042)

* Indicates Unit voltage: H = 208/230-3-60, L = 460-3-60, S = 575-3-60

† See model number nomenclature listing for gas heating options

RGS 072-180

ASHRAE 90.1 COMPLIANT PACKAGE GAS HEATING/ELECTRIC COOLING, R-410A SINGLE PACKAGE ROOFTOP 6 – 15 TONS

BUILT TO LAST, EASY TO INSTALL and SERVICE

- R-410A HFC refrigerant
- ASHRAE 90.1 energy compliant efficiency levels
- Single-stage cooling capacity control on 072 models.
- Two stage / two circuit cooling capacity control on 090-180 models
- Two stage /single circuit cooling capacity control on 089, 100, 199 models
- Rated in accordance with AHRI Standard 340/360
- Designed in accordance with Underwriters' Laboratories Standard 1995
- Listed by UL and UL, Canada or ETL and ETL, Canada
- Exclusive non-corrosive composite condensate pan in accordance with ASHRAE 62 Standard, sloping design; side or center drain
- Gas efficiencies up to 82%
- Induced draft combustion
- Redundant gas valve, with 1 or 2 stages of heating
- Pre-painted exterior panels and tested to 500 hours salt spray protection
- Fixed refrigerant metering system
- Fully insulated cabinet
- Exclusive IGC solid-state control for on-board diagnostics with LED error code designation, burner control logic.
- Cooling operating range from 40°F up to 115°F.
- Access panels with easy grip handles and no-strip screw feature
- Two-inch disposable return air filters
- Tool-less filter access door
- Standard belt drive, constant torque motor
- Advanced terminal board for simple safety circuit troubleshooting and control box arrangement
- Field Convertible from vertical to horizontal airflow on all models. No special kit required on 072-150 models. Field accessory supply duct kit required for 180 size model only
- Provisions for thru-the-bottom power entry capability
- Single point gas and electric connections
- Full perimeter base rail with built-in rigging adapters and fork truck slots
- Scroll compressors with internal line-break overload protection
- Copper tube, aluminum fin coils
- 24-volt control circuit protected with resettable circuit breaker
- Permanently lubricated evaporator-fan motor
- Permanently lubricated, totally enclosed, shaft down condenser motors
- Low pressure, freeze protection, and high pressure switches
- Exclusive IGC anti-cycle protection for gas heat operation
- Solid-state electronic direct spark ignition system
- Flame roll-out safety protector
- Liquid line filter drier

WARRANTY

- 15 Year limited warranty on stainless steel heat exchanger
- 10 Year limited warranty on aluminized heat exchanger
- 5 Year limited warranty on compressor
- 1 Year limited warranty on parts



RGS-072



RGS089-120



RGS180



RGS 072-180 (continued)

UNIT PERFORMANCE DATA — Single Stage Cooling /Single Circuit

UNIT	Nominal Tons	COOLING		GAS HEATING		Unit Dimensions H x W x L	Shipping Weight lb. [kg]
		Net. Cap (Btuh)	EER	Input Cap. (Btuh) Stage 2	Thermal Efficiency (%)		
RGS072**AA0AAA	6	70,000	11.0	72,000 - 150,000	80 - 82	41 3/8" x 46 3/4" x 74 3/8"	652 [296]

UNIT PERFORMANCE DATA — Dual Stage Cooling /Single Circuit

UNIT	Nominal Tons	COOLING		GAS HEATING		Unit Dimensions H x W x L	Shipping Weight lb. [kg]
		Net. Cap (Btuh)	EER	Input Cap. (Btuh) Stage 2	Thermal Efficiency (%)		
RGS089**AA0AAA	7 1/2	88,000	11.0	125,000 - 224,000	80 - 82	41 1/4" x 59 1/2" x 88 1/8"	810 [367]
RGS100**AA0AAA	8 1/2	97,000	11.0	125,000 - 224,000	82	49 3/8" x 59 1/2" x 88 1/8"	910 [413]
RGS119**AA0AAA	10	117,000	11.0	180,000 - 250,000	80 - 82	49 3/8" x 59 1/2" x 88 1/8"	965 [438]

UNIT PERFORMANCE DATA — Dual Stage Cooling / Two Circuits

UNIT	Nominal Tons	COOLING		GAS HEATING		Unit Dimensions H x W x L	Shipping Weight lb. [kg]
		Net. Cap (Btuh)	EER	Input Cap. (Btuh) Stage 2	Thermal Efficiency (%)		
RGS090**AA0AAA	7 1/2	83,000	11.0	125,000 - 224,000	82	41 1/4" x 59 1/2" x 88 1/8"	810 [367]
RGS102**AA0AAA	8 1/2	99,000	11.0	125,000 - 224,000	80 - 82	49 3/8" x 59 1/2" x 88 1/8"	910 [413]
RGS120**AA0AAA	10	114,000	11.1	180,000 - 250,000	80 - 82	49 3/8" x 59 1/2" x 88 1/8"	965 [438]
RGS150**AA0AAA	12 1/2	140,000	10.8	180,000 - 250,000	80 - 82	49 3/8" x 59 1/2" x 88 1/8"	1116 [506]
RGS180**AA0AAA	15	174,000	10.8	180,000 - 350,000	80 - 81	57 3/8" x 63 3/8" x 115 7/8"	1380 [627]

* Indicates Unit voltage: H = 208/230-3-60, L = 460-3-60, S = 575-3-60

^ See model nomenclature listing for gas heating options.

NOTE: BASE MODEL NUMBERS LISTED. SEE MODEL NOMENCLATURE LISTING FOR ADDITIONAL OPTIONS

RGS 210-336

ASHRAE 90.1 COMPLIANT PACKAGE GAS HEATING/ELECTRIC COOLING, VERTICAL SUPPLY/RETURN AIR CONFIGURATION ONLY R-410A SINGLE PACKAGE ROOFTOP 17.5 – 27.5 TONS

BUILT TO LAST, EASY TO INSTALL and SERVICE

- One-piece, standard efficiency gas heating and electric cooling with a low profile, prewired, tested, and charged at the factory
- Dedicated vertical air flow duct configuration models
- Full perimeter base rail with built-in rigging adapters and fork truck slots
- Pre-painted exterior panels and primer-coated interior panels tested to 500 hours salt spray protection
- Fully insulated cabinet
- Two-stage cooling with independent circuits and control on all models
- Redundant gas valve for two stage gas heating capacity control
- Exclusive IGC solid-state control for on-board diagnostics with LED error code designation, burner control logic and energy saving indoor fan motor delay
- High efficiency, gas heat with induced draft flue exhaust design
- Scroll compressors with internal line-break connections on all models
- All units have high and low pressure switches
- Two inch disposable fiberglass type return air filters in dedicated rack
- Refrigerant circuits contain a liquid line filter drier to trap dirt and moisture
- Round tube plate fin evaporator and condenser coil design
- Exclusive non-corrosive composite condensate pan in accordance with ASHRAE 62 Standard, sloping design; end drain
- Belt drive evaporator-fan motor and pulley combinations available to meet most applications
- Access panels with easy grip handles provide quick and easy access to the blower and blower motor, control box, and compressors
- “No-strip” screw system has superior holding power and guides screws into position while preventing the screw from stripping the unit’s metal.
- Newly designed terminal board facilitates simple safety circuit troubleshooting and simplified control box arrangement
- Standard outdoor temperature cooling operation range up to 115°F (46°C) and down to 30°F (-1°C)
- Fixed orifice metering devices on all models to precisely control refrigerant flow
- Large, laminated control wiring and power wiring drawings are affixed to unit to make troubleshooting easy
- Single point gas and electrical connections



17.5 Ton



20 and 25 Ton



WARRANTY

- 15 Year limited warranty on optional stainless steel heat exchanger
- 10 Year limited warranty on aluminized steel heat exchanger
- 5 Year compressor limited warranty
- 1 Year parts limited warranty



UNIT PERFORMANCE DATA — Two Stage Cooling								
UNIT	Dedicated Airflow	Nominal Tons	COOLING		GAS HEATING		Unit Dimensions H x W x L	Shipping Weight lb. [kg]
			Net. Cap (Btuh)	EER	Input Cap. (Btuh) Stage 2	Thermal Efficiency (%)		
RGS210*^AA0AAA	Vertical	17.5	208,000	10.8	220,000 - 400,000	81.0	49 3/8" x 86 5/8" x 127 7/8"	1948 [884]
RGS240*^AA0AAA	Vertical	20.0	242,000	9.8	220,000 - 400,000	81.0	49 3/8" x 86 5/8" x 141 1/2"	2098 [952]
RGS300*^AA0AAA	Vertical	25.0	280,000	9.8	220,000 - 400,000	81.0	57 3/8" x 86 5/8" x 141 1/2"	2234 [1013]
RGS336*^AA0AAA	Vertical	27.5	330,000	10.2	220,000 - 400,000	81.0	57 3/8" x 86 5/8" x 157 3/4"	2668 [1210]

* Indicates Unit voltage: H = 208/230-3-60, L = 460-3-60, S = 575-3-60

^ See model nomenclature listing for gas heating options.

NOTE: BASE MODEL NUMBERS LISTED. SEE MODEL NOMENCLATURE LISTING FOR ADDITIONAL OPTIONS

PACKAGE GAS HEATING/ELECTRIC COOLING, R-410A SINGLE PACKAGE ROOFTOP 3 - 5 TONS (1 & 3 Phase)

BUILT TO LAST, EASY TO INSTALL AND SERVICE

- R-410A HFC refrigerant
- Meets or exceeds ASHRAE 90.1 energy compliant efficiency levels
- Single-stage cooling capacity control
- Rated in accordance with ARI Standard 210/240
- Designed in accordance with Underwriters' Laboratories Standard 1995
- Listed by UL and UL, Canada
- Exclusive non-corrosive composite condensate pan in accordance with ASHRAE 62 Standard, sloping design; side or center drain
- Gas efficiencies up to 82%
- Induced draft combustion
- Redundant gas valve, with 1 or 2 stages of heating
- Pre-painted exterior panels and tested to 500 hours salt spray protection
- Fixed refrigerant metering system
- Fully insulated cabinet
- Exclusive IGC solid-state control for on-board diagnostics with LED error code designation, burner control logic.
- "Low NOx" models available that meet California Air Quality Management NOx requirements and include stainless steel heat exchangers
- Cooling operating range from 40 F up to 115 F.
- Access panels with easy grip handles and no-strip screw feature
- Two-inch disposable return air filters
- Tool-less filter access door
- Direct Drive ECM - indoor fan motor is standard with optional belt drive systems
- Advanced terminal board for simple safety circuit troubleshooting and control box arrangement
- Field Convertible from vertical to horizontal airflow on all models. No special kit required
- Provisions for thru-the-bottom power entry capability
- Single point gas and electric connections
- Full perimeter base rail with built-in rigging adapters and fork truck slots
- Scroll compressors with internal line-break overload protection
- Copper tube, aluminum fin coils
- 24-volt control circuit protected with resettable circuit breaker
- Permanently lubricated evaporator-fan motor
- Permanently lubricated, totally enclosed, shaft down condenser motors
- Low pressure, freeze protection, and high pressure switches
- Exclusive IGC anti-cycle protection for gas heat operation
- Solid-state electronic direct spark ignition system
- Flame roll-out safety protector
- Liquid line filter drier



Use of the AHRI Certified TM Mark indicates a manufacturer's participation in the program. For verification of certification for individual products, go to www.ahrirectory.org.



FACTORY OPTIONS INCLUDING BUT NOT LIMITED TO:

- Two position damper options
- Disconnect and convenience outlet options
- Supply air smoke detector and CO2 sensor options
- Multiple indoor fan motors for expanded airflow capability(3ph)
- Corrosion resistant coil options for evaporator and condenser
- Integrated economizer system. Standard and Ultra Low leak versions available.

LIMITED WARRANTY*

- 15 Year limited warranty on stainless steel heat exchanger
- 10 Year limited warranty on aluminized heat exchanger
- 5 Year limited warranty on compressor
- 1 Year limited warranty on parts

* See warranty certificate for details and restrictions

UNIT PERFORMANCE DATA - Single Stage Cooling								
UNIT	Nominal Tons	COOLING			GAS HEATING		Unit Dimensions H x W x L in(mm)	Unit Weight lb. [kg]
		Net Cap. (Btuh)	SEER	EER	Input Cap. (Btuh)	Thermal Eff. %		
RGX036**^XA0AAA	3	35,400	14.0	12.0	50,000 - 89,000	80-82	33-3/8 x 46-3/4 x 74-3/8 (847 x 1187 x 1888)	490 [222]
RGX048**^XA0AAA	4	47,500	14.0	12.0	50,000 - 117,000	80-82	33-3/8 x 46-3/4 x 74-3/8 (847 x 1187 x 1888)	544 [246]
RGX060**^XA0AAA	5	58,500	14.1	12.0	50,000 - 117,000	80-82	41-3/8 x 46-3/4 x 74-3/8 (1051 x 1187 x 1888)	597 [270]

* Indicates Unit voltage: K = 208/230-1-60, H = 208/230-3-60, L = 460-3-60, S = 575-3-60

^ See model nomenclature listing for gas heating options.

NOTE: BASE MODEL NUMBERS LISTED. SEE MODEL NOMENCLATURE LISTING FOR ADDITIONAL OPTIONS

Specifications subject to change without notice.

RAH 036-150

HIGH-EFFICIENCY PACKAGE ELECTRIC COOLING, R-410A SINGLE PACKAGE ROOFTOP 3 - 12.5 TONS [1 & 3-Phase]

BUILT TO LAST, EASY TO INSTALL AND SERVICE

- One-piece, high efficiency electric cooling with a low profile, prewired, tested, and charged at the factory.
- Field convertible from vertical to horizontal airflow on all models. No special kit required on 036-120 models. Field accessory supply duct kit required for 150 size model only.
- Full perimeter base rail with built-in rigging adapters and fork truck slots.
- Pre-painted exterior panels and primer-coated interior panels tested to 500 hours salt spray protection.
- Fully insulated cabinet.
- Single-stage cooling capacity control on 036-072 models.
- Two-stage cooling capacity control on 073-150 models.
- Single scroll compressor on 036-073 models, dual scroll compressors on 090-150 models with internal line-break overload protection.
- Two inch disposable fiberglass type return air filters in dedicated rack with tool-less filter access door.
- All units have a high and low pressure switches.
- Refrigerant circuits contain a liquid line filter drier to trap dirt and moisture.
- Indoor and outdoor coils constructed of aluminum fins mechanically bonded to seamless copper tubes.
- Newly designed indoor refrigerant header for easier maintenance and replacement.
- Exclusive non-corrosive composite condensate pan in accordance with ASHRAE 62 Standard, sloping design; side or center drain.
- Direct drive high-efficiency ECM blower motors on 036-060 single phase models.
- Belt drive evaporator-fan motor and pulley combinations available on all three phase models.
- Access panels with easy grip handles provide quick and easy access to the blower and blower motor, control box, and compressor.
- “No-strip” screw system has superior holding power and guides screws into position while preventing the screw from stripping the unit’s metal.
- Central terminal board facilitates simple safety circuit troubleshooting and simplified control box arrangement.
- Outdoor temperature cooling operation range up to 125°F [52°C] and down to 35°F [-2°C] using winter start kit.
- TXV refrigerant metering devices on all models to precisely control refrigerant flow.
- Large, laminated control wiring and power wiring drawings are affixed to unit to make troubleshooting easy.
- Standard, medium, and high static fan motor options available.
- Provisions for thru-the-bottom power entry capabilities.
- Single point electrical connection.



RAH036-060



RAH072-120



OR



Intertek

WARRANTY

- 5 year compressor limited warranty
- 1 year standard parts limited warranty



RAH 036-150 (continued)

SINGLE STAGE COOLING

UNIT	NOM. TONS	COOLING			UNIT DIMENSIONS H x W x L in (mm)	UNIT WEIGHT lb. (kg)
		NET CAP. (Btuh)	SEER	EER		
RAH036*0XA0AAA	3	35,400	15.0	12.50	33 ³ / ₈ x 46 ³ / ₄ x 74 ³ / ₈ (847 x 1187 x 1888)	458 (208)
RAH048*0XA0AAA	4	48,500	15.6	13.00	41 ³ / ₈ x 46 ³ / ₄ x 74 ³ / ₈ (1051 x 1187 x 1888)	545 (207)
RAH060*0XA0AAA	5	57,500	15.2	12.45	41 ³ / ₈ x 46 ³ / ₄ x 74 ³ / ₈ (1051 x 1187 x 1888)	550 (249)
RAH072*0XA0AAA	6	73,000	N/A	12.20	41 ¹ / ₄ x 59 ¹ / ₂ x 88 ¹ / ₈ (1048 x 1510 x 2238)	715 (324)

TWO STAGE COOLING

UNIT	NOM. TONS	COOLING			UNIT DIMENSIONS H x W x L in (mm)	UNIT WEIGHT lb. (kg)
		NET CAP. (Btuh)	SEER	EER		
RAH073*0AA0AAA	6.0	72,000	N/A	12.20	41 ¹ / ₄ x 59 ¹ / ₂ x 88 ¹ / ₈ (1048 x 1510 x 2238)	765 (347)
RAH090*0AA0AAA	7.5	89,000	N/A	12.20	49 ³ / ₈ x 59 ¹ / ₂ x 88 ¹ / ₈ (1253 x 1510 x 2238)	925 (420)
RAH102*0AA0AAA	8.5	97,000	N/A	12.20	49 ³ / ₈ x 59 ¹ / ₂ x 88 ¹ / ₈ (1253 x 1510 x 2238)	925 (420)
RAH110*0AA0AAA	10.0	111,000	N/A	12.00	49 ³ / ₈ x 59 ¹ / ₂ x 88 ¹ / ₈ (1253 x 1510 x 2238)	1090 (495)
RAH120*0AA0AAA	10.0	115,000	N/A	11.70	49 ³ / ₈ x 59 ¹ / ₂ x 88 ¹ / ₈ (1253 x 1510 x 2238)	1090 (495)
RAH150*0AA0AAA	12.5	146,000	N/A	12.40	57 ³ / ₈ x 63 ³ / ₈ x 115 ⁷ / ₈ (1456 x 1609 x 2942)	1430 (649)

Specifications subject to change without notice.

HIGH-EFFICIENCY PACKAGE ELECTRIC COOLING, R-410A SINGLE PACKAGE ROOFTOP 15-25 TONS [3-Phase]

BUILT TO LAST, EASY TO INSTALL AND SERVICE

- One-piece, high efficiency electric cooling with a low profile, prewired, tested, and charged at the factory
- Dedicated vertical and horizontal air flow duct configuration models. No field kits required
- Two stage cooling capacity with independent circuits and control
- Pre-painted exterior panels and primer-coated interior panels tested to 500 hours salt spray protection
- Fully insulated cabinet
- Full perimeter base rail with built-in rigging adapters and fork truck slots
- Scroll compressors on all models
- All units have high and low pressure switches
- Two inch disposable fiberglass type return air filters in dedicated rack with tool-less filter access door
- Refrigerant circuits contain a liquid line filter drier to trap dirt and moisture
- Exclusive non-corrosive composite condensate pan in accordance with ASHRAE 62 Standard, sloping design; end drain
- Belt drive evaporator-fan motor and pulley combinations available to meet most applications
- Access panels with easy grip handles provide quick and easy access to the blower and blower motor, control box, and compressors
- "No-strip" screw system has superior holding power and guides screws into position while preventing the screw from stripping the unit's metal.
- Newly designed terminal board facilitates simple safety circuit troubleshooting and simplified control box arrangement
- Standard outdoor temperature cooling operation range up to 125°F (52°C) and down to 35°F to (2°C)
- TXV metering device on all models to precisely control refrigerant flow
- Large, laminated wiring and power wiring drawings which are affixed to unit make troubleshooting easy
- Capable of thru-the-base or thru-the-curb electrical routing
- Full range of electric heaters and single point electrical connections

WARRANTY

- 5 year compressor limited warranty
- 1 year standard parts limited warranty



15 Ton



OR



Intertek



RAH 181-303 (continued)

UNIT	DEDICATED AIRFLOW	NOMINAL TONS	COOLING			TOTAL POWER (kW)	UNIT DIMENSIONS (H x W x L)	UNIT WEIGHT lb [kg]
			Net Cap. (Btuh)	EER	IEER			
RAH181*0AA0AAA	Vertical	15.0	174,000	12.2	13.2	14.3	48 ³ / ₈ x 86 ³ / ₈ x 127 ⁷ / ₈	1793 [815]
RAH183*0AA0AAA	Horizontal	15.0	174,000	11.8	12.4	14.3	48 ³ / ₈ x 86 ³ / ₈ x 127 ⁷ / ₈	1793 [815]
RAH210*0AA0AAA	Vertical	17.5	202,000	12.2	13.2	16.6	48 ³ / ₈ x 86 ³ / ₈ x 141 ¹ / ₂	2003 [911]
RAH213*0AA0AAA	Horizontal	17.5	202,000	11.7	12.5	16.6	48 ³ / ₈ x 86 ³ / ₈ x 141 ¹ / ₂	2003 [911]
RAH240*0AA0AAA	Vertical	20.0	232,000	12.2	13.4	19.3	48 ³ / ₈ x 86 ³ / ₈ x 141 ¹ / ₂	2148 [976]
RAH243*0AA0AAA	Horizontal	20.0	232,000	11.8	12.9	19.3	48 ³ / ₈ x 86 ³ / ₈ x 141 ¹ / ₂	2148 [976]
RAH300*0AA0AAA	Vertical	25.0	282,000	11.4	12.2	25.2	48 ³ / ₈ x 86 ³ / ₈ x 157 ³ / ₄	2193 [997]
RAH303*0AA0AAA	Horizontal	25.0	282,000	10.9	11.3	25.2	48 ³ / ₈ x 86 ³ / ₈ x 157 ³ / ₄	2193 [997]

Specifications subject to change without notice.

ELECTRIC COOLING, R-410A SINGLE PACKAGE ROOFTOP 6 - 15 TONS (3-PHASE)

BUILT TO LAST, EASY TO INSTALL and SERVICE

- Single-stage cooling capacity control on 072 models
- Two-stage/two circuit cooling capacity control on 090-180 models
- Two-stage/single circuit cooling capacity control on 089, 100, 119 models
- Rated in accordance with AHRI Standard 340/360
- EERs up to 11.3
- IEERs up to 12.2 with single speed indoor fan motor
- IEERs up to 13.0 with 2-speed/VFD indoor fan motor
- Designed in accordance with Underwriters' Laboratories Standard 1995
- Listed by UL and UL, Canada or ETL and ETL, Canada
- Exclusive non-corrosive composite condensate pan in accordance with ASHRAE 62 Standard, sloping design; side or center drain
- Pre-painted exterior panels and primer-coated interior panels tested to 500 hours salt spray protection
- Fixed refrigerant metering system
- Fully insulated cabinet
- Cooling operating range from 40°F up to 115°F
- Access panels with easy grip handles and no-strip screw feature
- Two-inch disposable return air filters
- Tool-less filter access door
- Standard belt drive, constant torque motor
- Advanced terminal board for simple safety circuit troubleshooting and control box arrangement
- Field Convertible from vertical to horizontal airflow configuration on all models. No special kit required on 072-150 models. Field accessory supply duct kit required for 180 size models only.
- Provisions for thru-the-bottom power entry capability
- Single point electric connections
- Full perimeter base rail with built-in rigging adapters and fork truck slots
- Scroll compressors with internal line-break overload protection Copper tube, aluminum fin coils
- 24-volt control circuit protected with resettable circuit breaker
- Permanently lubricated evaporator-fan motor
- Permanently lubricated, totally enclosed condenser-fan motors
- Low pressure, freeze protection, and high-pressure switches
- Liquid line filter drier standard

FACTORY OPTIONS INCLUDING BUT NOT LIMITED TO:

- Economizer and two position damper options
- Disconnect and convenience outlet options
- Multiple optional motor and pulley combinations
- Corrosion resistant options for evaporator and condenser coils
- 2 speed indoor fan motor on 2 stage cooling models
- Integrated economizer system. Standard and Ultra Low Leak versions available

WARRANTY

- 5 Year limited warranty on compressor
- 5 Year limited warranty on electric heater parts
- 1 Year limited warranty on parts



RAS-072



RAS089-120



RAS180



RAS 072-180 (continued)

UNIT PERFORMANCE DATA — Single Stage Cooling/Single Circuit

UNIT	COOLING				Unit Dimensions H x W x L Inches (mm)	Unit Weight lb. [kg]
	Nominal Tons	Net. Cap (Btuh)	EER	Total Power (kW)		
RAS072*0AA0AAA	6	70,000	11.2	6.4	41-3/8" x 46-3/4" x 74-3/8" (1051 x 1187 x 1888)	607 [275]

UNIT PERFORMANCE DATA — Two Stage Cooling/Single Circuit

UNIT	COOLING				Unit Dimensions H x W x L Inches (mm)	Unit Weight lb. [kg]
	Nominal Tons	Net. Cap (Btuh)	EER	Total Power (kW)		
RAS089*0AA0AAA	7-1/2	88,000	11.0	8.0	41-3/8" x 59-1/2" x 88-1/8" (1051 x 1510 x 2238)	705 [320]
RAS100*0AA0AAA	8-1/2	97,000	11.2	8.8	49-3/8" x 59-1/2" x 88-1/8" (1253 x 1510 x 2238)	845 [384]
RAS119*0AA0AAA	10	117,000	11.2	10.6	49-3/8" x 59-1/2" x 88-1/8" (1253 x 1510 x 2238)	855 [388]

UNIT PERFORMANCE DATA — Dual Stage Cooling/Two Circuits

UNIT	COOLING				Unit Dimensions H x W x L Inches (mm)	Unit Weight lb. [kg]
	Nominal Tons	Net. Cap (Btuh)	EER	Total Power (kW)		
RAS090*0AA0AAA	7-1/2	83,000	11.2	7.4	41-3/8" x 59-1/2" x 88-1/8" (1051 x 1510 x 2238)	760 [345]
RAS102*0AA0AAA	8-1/2	97,000	11.2	9.0	49-3/8" x 59-1/2" x 88-1/8" (1253 x 1510 x 2238)	855 [388]
RAS120*0AA0AAA	10	114,000	11.3	10.1	49-3/8" x 59-1/2" x 88-1/8" (1253 x 1510 x 2238)	865 [393]
RAS150*0AA0AAA	12-1/2	140,000	11.0	12.7	49-3/8" x 59-1/2" x 88-1/8" (1253 x 1510 x 2238)	1075 [489]
RAS180*0AA0AAA	15	174,000	11.0	15.8	57-3/8" x 63-3/8" x 115-7/8" (1456 x 1609 x 2942)	1305 [593]

* Indicates Unit voltage: H = 208/230-3-60, L = 460-3-60, S = 575-3-60

NOTE: BASE MODEL NUMBERS LISTED. SEE MODEL NOMENCLATURE LISTING FOR ADDITIONAL OPTIONS

Specifications subject to change without notice.

RAS 210-336

ASHRAE 90.1 COMPLIANT PACKAGED ROOFTOP ELECTRIC COOLING UNITS, VERTICAL SUPPLY AND RETURN CONFIGURATION ONLY R-410A, 17.5 - 27.5 TONS

BUILT TO LAST, EASY TO INSTALL AND SERVICE

- One-piece, standard efficiency electric cooling with a low profile, prewired, tested, and charged at the factory
- Dedicated vertical air flow duct configuration models.
- Full perimeter base rail with built-in rigging adapters and fork truck slots
- Pre-painted exterior panels and primer-coated interior panels tested to 500 hours salt spray protection
- Fully insulated cabinet
- Two-stage cooling with independent circuits and control on all models
- Scroll compressors with internal line-break connections on all models
- All units have high and low pressure switches
- Two inch disposable fiberglass type return air filters in dedicated rack
- Refrigerant circuits contain a liquid line filter drier to trap dirt and moisture
- Round tube plate fin evaporator and condenser coil design
- Exclusive non-corrosive composite condensate pan in accordance with ASHRAE 62 Standard, sloping design; end drain
- Belt drive evaporator-fan motor and pulley combinations available to meet most applications
- Access panels with easy grip handles provide quick and easy access to the blower and blower motor, control box, and compressors.
- “No-strip” screw system has superior holding power and guides screws into position while preventing the screw from stripping the unit’s metal.
- Newly designed terminal board facilitates simple safety circuit troubleshooting and simplified control box arrangement
- Standard outdoor temperature cooling operation range up to 115°F (46°C) and down to 35°F (2°C)
- Fixed orifice metering devices on all models to precisely control refrigerant flow
- Large, laminated control wiring and power wiring drawings are affixed to unit to make troubleshooting easy
- Single point electrical connections

WARRANTY

- 5 Year compressor limited warranty
- 1 Year parts limited warranty



17.5 Ton



20 & 25 Ton



Use of the AHRI Certified TM Mark indicates a manufacturer’s participation in the program. For verification of certification for individual products, go to www.ahrirectory.org.



UNIT PERFORMANCE DATA – Two Stage Cooling							
UNIT	Dedicated Airflow	Nominal Tons	COOLING		Total Power (kW)	Unit Dimensions H x W x L	Unit Weight lb. [kg]
			Net Cap. (Btuh)	EER			
RAS210*0AA0AAA	Vertical	17.5	208,000	11.0	18.9	49-3/8" x 86-5/8" x 127-7/8"	2243 [1017]
RAS240*0AA0AAA	Vertical	20	242,000	10.0	24.2	49-3/8" x 86-5/8" x 141-1/2"	2277 [1033]
RAS300*0AA0AAA	Vertical	25	280,000	10.0	28.0	57-3/8" x 86-5/8" x 141-1/2"	2525 [1145]
RAS336*0AA0AAA	Vertical	27.5	330,000	10.4	31.7	57-3/8" x 86-5/8" x 157-3/4"	2513 [1142]

* Indicates Unit voltage: H = 208/230–3–60, L = 460–3–60, S = 575–3–60

NOTE: BASE MODEL NUMBERS LISTED. SEE MODEL NOMENCLATURE LISTING FOR ADDITIONAL OPTIONS

Specifications subject to change without notice.

PACKAGE ELECTRIC COOLING UNIT R-410A SINGLE PACKAGE ROOFTOP 3 - 5 TONS (1 & 3-Phase)

BUILT TO LAST, EASY TO INSTALL AND SERVICE

- ASHRAE 90.1 energy compliant efficiency levels
- Single-stage cooling capacity control on all models
- Rated in accordance with AHRI Standard 210/240 (036-060 sizes)
- SEER's up to 14.1, EER's up to 12.0
- Exclusive non-corrosive composite condensate pan in accordance with ASHRAE 62 Standard, sloping design; side or center drain
- Convertible from vertical to horizontal airflow for slab mounting
- Copper tube aluminum fin coils with optional corrosion resistant coils
- Pre-painted exterior panels and tested to 500 hours salt spray protection
- Fixed orifice refrigerant metering system
- Cooling operating range up to 115°F (46°C) and down to 25°F (-4°C)
- Solid-state control board and easy access terminal board
- Refrigerant filter drier and accumulator on each refrigerant circuit
- Automatic changeover when used with auto-changeover thermostat
- Rated in accordance with AHRI Standards 210/240 (036-060)
- Designed in accordance with Underwriters' Laboratories Std 1995
- Listed by UL and UL, Canada



Use of the AHRI Certified TM Mark indicates a manufacturer's participation in the program. For verification of certification for individual products, go to www.ahrirectory.org.



MAINTENANCE FEATURES

- Access panels with easy grip handles
- Innovative, easy starting, no strip screw features on unit access panels.
- Two-inch disposable return air filters with tool-less filter access door
- Belt drive evaporator-fan motor and pulley combinations available on all sizes to meet any application
- Direct Drive ECM - indoor motor is standard with optional belt drive systems
- Advanced terminal board facilitating simple safety circuit troubleshooting and simplified control box arrangement

INSTALLATION FEATURES

- Thru-the-bottom power entry capability standard
- Single point electric connections
- Full perimeter base rail with built-in rigging adapters & fork truck slots

RELIABILITY FEATURES

- Scroll compressors with internal line break overload protection
- 24-volt control circuit protected with resettable circuit breaker
- Permanently lubricated evaporator-fan motor
- Totally enclosed condenser motors with permanently lubricated bearings
- Low pressure, freeze protection, and high-pressure switches

FACTORY OPTIONS INCLUDING BUT NOT LIMITED TO:

- Two position damper options
- Disconnect and convenience outlet options
- Supply air smoke detector and CO₂ sensor options
- Multiple indoor fan motors for expanded airflow capability (3ph)
- Corrosion resistant coil options for evaporator and condenser
- Accessory electric heat (field-installed option only)
- Integrated economizer system. Standard and Ultra Low leak versions available.

LIMITED WARRANTY *

- 5 year electric heater parts
- 5 year compressor limited warranty
- 1 year parts limited warranty

* See warranty certificate for complete details and restrictions

UNIT PERFORMANCE DATA							
BASE MODEL	Nominal Tons	Net Cap. (Btuh)	SEER	EER	Total Power (kW)	Unit Dimensions H x W x L	Unit Weight lbs (kg)
RAX036*0XA0AAA	3	35,400	14.00	12.00	3.0	33-3/8 x 46-3/4 x 74-3/8 (847 x 1187 x 1888)	445 (201)
RAX048*0XA0AAA	4	47,500	14.00	12.00	4.0	33-3/8 x 46-3/4 x 74-3/8 (847 x 1187 x 1888)	499 (226)
RAX060*0XA0AAA	5	58,500	14.10	12.00	4.9	41-3/8 x 46-3/4 x 74-3/8 (1051 x 1187 x 1888)	552 (250)

* Indicates Unit voltage: K = 208/230-1-60, H = 208/230-3-60, L = 460-3-60, S = 575-3-60

NOTE: BASE MODEL NUMBERS LISTED. SEE MODEL NOMENCLATURE LISTING FOR ADDITIONAL OPTIONS

Specifications subject to change without notice.

HIGH-EFFICIENCY PACKAGE HEAT PUMPS, R-410A SINGLE PACKAGE ROOFTOP 3 - 10 TONS [1 & 3-Phase]

BUILT TO LAST, EASY TO INSTALL AND SERVICE

- ASHRAE 90.1-2013 compliant and ENERGY STAR* certified
- SEERs up to 15.8, EERs up to 12.8
- IEERs up to 14.0 with single speed indoor fan motor
- IEERs up to 15.6 with 2-speed/VFD indoor fan motor
- Exclusive non-corrosive composite condensate pan in accordance with ASHRAE 62 Standard, sloping design; side or center drain
- Convertible from vertical to horizontal airflow for slab mounting. Supply duct kit required for 120 size models.
- Copper tube aluminum fin coils with optional corrosion resistant coils
- Pre-painted exterior panels and primer coated interior panels tested to 500 hours salt spray protection
- TXV refrigerant metering system on each circuit
- Cooling operating range up to 125°F (52°C) and down to 30°F (-1°C)
- Solid-state control board and easy access terminal board
- Refrigerant filter drier and accumulator on each refrigerant circuit
- Automatic changeover when used with auto-changeover thermostat
- Rated in accordance with AHRI Standards 210/240 (036-060) and 340/360 (072-120)
- Designed in accordance with Underwriters' Laboratories Std 1995
- Listed by UL and UL, Canada or ETL, ETL Canada
- Access panels with easy grip handles
- Innovative, easy starting, no strip screw features on unit access panels.
- Two-inch disposable return air filters
- Tool-less filter access door
- Belt drive evaporator-fan motor and pulley combinations available on all three phase sizes to meet any application
- Direct Drive X13 (5 speed/torque) indoor motor on 036-060 models
- Central terminal board facilitating simple safety circuit troubleshooting and simplified control box arrangement
- Thru-the-bottom power entry capability standard
- Single point electric connections
- Full perimeter base rail with built-in rigging adapters & fork truck slots
- Scroll compressors with internal line break overload protection
- Dependable Time / Temperature defrost board and logic
- 24-volt control circuit protected with resettable circuit breaker
- Permanently lubricated evaporator-fan motor
- Totally enclosed condenser motors with permanently lubricated bearings
- Loss of charge, freeze protection, and high-pressure switches

OPTIONS AND ACCESSORIES INCLUDING BUT NOT LIMITED TO:

- 115-volt convenience outlet (powered and unpowered)
- Non-fused disconnect switch
- Economizer with db, enthalpy or CO₂ control options
- Corrosion resistant coil options for evaporator and condenser
- Multiple indoor fan motors for expanded airflow capability (3ph)
- Accessory electric heat (field-installed option only)
- Smoke detectors – Supply and Return air
- Hinged access panels
- 2-Speed indoor fan motor with VFD controller on 073 to 120 size models
- Standard and Ultra low leak economizers available

LIMITED WARRANTY

- 5 Year compressor limited warranty
- 1 Year parts limited warranty

* ENERGY STAR is a registered trademark of the U.S. Environmental Protection Agency.



RHH036-060



RHH072-120



OR



Intertek



Use of the AHRI Certified TM Mark indicates a manufacturer's participation in the program. For verification of certification for individual products, go to www.ahridirectory.org.

RHH 036-120 (continued)

UNIT PERFORMANCE DATA									
BASE MODEL	Nom Tons	COOLING			HEATING			Unit Dimensions H x W x L in. (mm)	Unit Weight lbs (kg)
		Net Cap. (Btuh)	SEER	EER	High Cap. (Btuh)	HSPF	COP		
RHH036*0XA0AAA	3	36,400	15.6	12.7	34,000	8.0	N/A	33 ³ / ₈ x 46 ³ / ₄ x 74 ³ / ₈ (847 x 1187 x 1888)	495 (225)
RHH048*0XA0AAA	4	47,000	15.8	12.8	46,000	8.1	N/A	41 ³ / ₈ x 46 ³ / ₄ x 74 ³ / ₈ (1051 x 1187 x 1888)	580 (263)
RHH060*0XA0AAA	5	58,500	15.0	11.7	55,000	8.2	N/A	41 ³ / ₈ x 46 ³ / ₄ x 74 ³ / ₈ (1051 x 1187 x 1888)	610 (277)
RHH072*0AA0AAA	6	72,000	N/A	12.0	70,000	N/A	3.4	41 ³ / ₈ x 59 ¹ / ₂ x 88 ¹ / ₈ (1051 x 1510 x 2238)	710 (322)
RHH073*0AA0AAA	6	70,000	N/A	12.0	69,000	N/A	3.4	41 ³ / ₈ x 59 ¹ / ₂ x 88 ¹ / ₈ (1051 x 1510 x 2238)	710 (322)
RHH090*0AA0AAA	7 ¹ / ₂	90,000	N/A	12.1	84,000	N/A	3.5	49 ³ / ₈ x 59 ¹ / ₂ x 88 ¹ / ₈ (1253 x 1510 x 2238)	875 (397)
RHH102*0AA0AAA	8 ¹ / ₂	100,000	N/A	12.0	100,000	N/A	3.4	49 ³ / ₈ x 59 ¹ / ₂ x 88 ¹ / ₈ (1253 x 1510 x 2238)	1020 (463)
RHH120*0AA0AAA	10	119,000	N/A	12.3	116,000	N/A	3.5	57 ³ / ₈ x 63 ³ / ₈ x 115 ⁷ / ₈ (1456 x 1609 x 2942)	1390 (632)

* Indicates Unit voltage: K = 208/230-1-60, H = 208/230-3-60, L = 460-3-60, S = 575-3-60

Specifications subject to change without notice

PACKAGED HEAT PUMP UNIT R-410A SINGLE PACKAGE ROOFTOP 6 - 12.5 TONS

BUILT TO LAST, EASY TO INSTALL AND SERVICE

- R-410A HFC refrigerant
- ASHRAE 90.1 Energy Compliant
- EER up to 11.2
- IEER up to 12.5 with single speed indoor fan motor and up to 12.7 with 2-speed /VFD indoor fan motor
- COP up to 3.5
- Single stage cooling capacity control on 072 models
- Two-stage cooling capacity control on 090 to 150 models
- Exclusive non-corrosive composite condensate pan in accordance with ASHRAE 62 Standard, sloping design; side or center drain
- Convertible from vertical to horizontal airflow for slab mounting
- Copper tube aluminum fin coils with optional corrosion resistant coils
- Pre-painted exterior panels and tested to 500 hours salt spray protection
- Fixed orifice refrigerant metering system
- Cooling operating range up to 115°F (46°C) and down to 25°F (-4°C)
- Solid-state control board and easy access terminal board
- Refrigerant filter drier and accumulator on each refrigerant circuit
- Automatic changeover when used with auto-changeover thermostat
- Rated in accordance with AHRI Standards 340/360
- Designed in accordance with Underwriters' Laboratories Std 1995
- Listed by UL and UL, Canada or ETL and ETL, Canada

MAINTENANCE FEATURES

- Access panels with easy grip handles
- Innovative, easy starting, no strip screw features on unit access panels.
- Two-inch disposable return air filters with tool-less filter access door
- Belt drive evaporator-fan motor and pulley combinations available on all sizes to meet any application
- Central terminal board facilitating simple safety circuit troubleshooting and simplified control box arrangement

INSTALLATION FEATURES

- Thru-the-bottom power entry capability standard
- Single point electric connections

- Full perimeter base rail with built-in rigging adapters and fork truck slots

RELIABILITY FEATURES

- Scroll compressors with internal line break overload protection
- Dependable Time / Temperature defrost board and logic
- 24-volt control circuit protected with resettable circuit breaker
- Permanently lubricated evaporator-fan motor
- Totally enclosed condenser motors with permanently lubricated bearings
- Loss of charge, freeze protection, and high-pressure switches

FACTORY OPTIONS INCLUDING BUT NOT LIMITED TO:

- 115-volt convenience outlet (Non-powered)
- Non-fused disconnect switch
- Economizer with db, enthalpy or CO₂ control options
- Corrosion resistant coil options for evaporator and condenser
- Multiple indoor fan motors for expanded airflow capability (3ph)
- Accessory electric heat (field-installed option only)
- 2 speed indoor fan motor on 2 stage cooling models.
- Integrated economizer system. Standard and Ultra Low leak versions available.

WARRANTY

- 5 Year compressor limited warranty
- 1 Year parts limited warranty



RHS072



RHS090-102



UNIT PERFORMANCE DATA							
BASE MODEL	Nominal Tons	COOLING		HEATING		Unit Dimensions H x W x L	Unit Weight lbs (kg)
		Net Cap. (Btuh)	EER	High Cap. (Btuh)	COP		
RHS072*0AA0AAAT	6	69,000	11.10	66,000	3.5	41-3/8" x 46-3/4" x 74-3/8"	630 (286)
RHS090*0AA0AAAT	7.5	88,000	11.20	86,000	3.4	49-3/8" x 59-1/2" x 88-1/8"	885 (401)
RHS102*0AA0AAAT	8.5	99,000	11.20	96,000	3.3	49-3/8" x 59-1/2" x 88-1/8"	910 (413)
RHS120*0AA0AAAT	10	117,000	11.00	116,000	3.3	49-3/8" x 59-1/2" x 88-1/8"	1050 (476)
RHS150*0AA0AAAT	12.5	142,000	10.60	142,000	3.2	57-3/8" x 63-3/8" x 115-7/8"	1370 (623)

* Indicates Unit voltage: H = 208/230-3-60, L = 460-3-60, S = 575-3-60

Specifications subject to change without notice

ASHRAE 90.1 COMPLIANT PACKAGED ROOFTOP HEAT PUMP UNITS, R-410A, 15 - 20 TONS

BUILT TO LAST, EASY TO INSTALL AND SERVICE

- IEERs up to 11.5 with single speed indoor fan motor and up to 12.0 with 2-speed/VFD indoor fan motor
- One-piece electric heating and electric cooling units with a low profile, prewired, tested, and charged at the factory
- Dedicated vertical or horizontal air flow duct configuration models. No field kits required.
- Full perimeter base rail with built-in rigging adapters and fork truck slots
- Pre-painted exterior panels and primer-coated interior panels tested to 500 hours salt spray protection
- Fully insulated cabinet
- Two-stage cooling with independent circuits and control on all models
- Scroll compressors with internal line-break overload protection on all models
- All units have loss of charge, freeze protection and high pressure switches
- Two inch disposable fiberglass type return air filters in dedicated rack with tool-less filter access door
- Liquid line filter drier and refrigerant accumulator on each circuit
- Dependable time/temperature defrost logic provides a defrost cycle, if needed, every 30, 60, 90, or 120 minutes and is adjustable
- Copper round tube and aluminum plate fin condenser and evaporator coils
- Exclusive non-corrosive composite condensate pan in accordance with ASHRAE 62 Standard, sloping design; end drain
- Belt drive evaporator-fan motor and pulley combinations available to meet most applications
- Access panels with easy grip handles provide quick and easy access to the blower and blower motor, control box, and compressors.
- “No-strip” screw system has superior holding power and guides screws into position while preventing the screw from stripping the unit’s metal.
- Newly designed terminal board facilitates simple safety circuit troubleshooting and simplified control box arrangement
- Outdoor temperature cooling operation range up to 115°F (46°C) and down to 30°F (-15°C). Low ambient controls are available for cooling operation down to -20°F (-29°C).
- TXV metering devices on all models to precisely control refrigerant flow
- Large, laminated control wiring and power wiring drawings are affixed to unit to make troubleshooting easy
- Standard, medium and high static fan motor options available (Standard static not available on horizontal 20 ton models)
- Optional 2-Speed Indoor Fan Motor System utilizes a Variable Frequency Drive (VFD) to automatically adjust the indoor fan motor speed between cooling stages. Available on 2-stage cooling models
- Provisions for thru-the-bottom or side power entry capability
- Single point electrical connections



15 Ton



Use of the AHRI Certified TM Mark indicates a manufacturer's participation in the program. For verification of certification for individual products, go to www.ahrirectory.org.



WARRANTY

- 5 Year compressor limited warranty
- 1 Year parts limited warranty

UNIT PERFORMANCE DATA – Two Stage Cooling									
UNIT	Dedicated Airflow	Nom. Tons	COOLING		HEATING		Total Power (kW)	Unit Dimensions H x W x L Inches (mm)	Unit Weight lb. [kg]
			Net Cap. (Btuh)	EER	HighCap. (Btuh)	COP			
RHS181*0AA0AAA	Vertical	15	172,000	10.8	166,000	3.3	15.9	49-3/8 x 86-3/8 x 127-7/8 (1253 x 2194 x 3249)	1775 [807]
RHS183*0AA0AAA	Horizontal	15	172,000	10.8	166,000	3.3	15.9	49-3/8 x 86-3/8 x 127-7/8 (1253 x 2194 x 3249)	1775 [807]
RHS240*0AA0AAA	Vertical	20	232,000	10.6	220,000	3.3	21.9	49-3/8 x 86-3/8 x 141-1/2 (1253 x 2194 x 3595)	2100 [955]
RHS243*0AA0AAA	Horizontal	20	232,000	10.6	220,000	3.3	21.9	49-3/8 x 86-3/8 x 141-1/2 (1253 x 2194 x 3595)	2100 [955]

* Indicates Unit voltage: H = 208/230-3-60, L = 460-3-60, S = 575-3-60

NOTE: BASE MODEL NUMBERS LISTED. SEE MODEL NOMENCLATURE LISTING FOR ADDITIONAL OPTIONS

Specifications subject to change without notice

PACKAGE HEAT PUMP UNIT R-410A SINGLE PACKAGE ROOFTOP 3 - 5 TONS (1 & 3-Phase)

BUILT TO LAST, EASY TO INSTALL AND SERVICE

- Meets or exceeds ASHRAE 90.1 energy compliant efficiency levels
- SEERs up to 14.3, EERs up to 12.2
- HSPF's up to 8.2
- Single stage cooling capacity control
- Exclusive non-corrosive composite condensate pan in accordance with ASHRAE 62 Standard, sloping design; side or center drain
- Convertible from vertical to horizontal airflow for slab mounting
- Copper tube aluminum fin coils with optional corrosion resistant coils
- Pre-painted exterior panels and tested to 500 hours salt spray protection
- Fixed orifice refrigerant metering system
- Cooling operating range up to 115°F (46°C) and down to 25°F (-4°C)
- Solid-state control board and easy access terminal board
- Refrigerant filter drier and accumulator on each refrigerant circuit
- Automatic changeover when used with auto-changeover thermostat
- Rated in accordance with AHRI Standards 210/240 (036-060)
- Designed in accordance with Underwriters' Laboratories Std 1995
- Listed by UL and UL, Canada

MAINTENANCE FEATURES

- Access panels with easy grip handles
- Innovative, easy starting, no strip screw features on unit access panels.
- Two-inch disposable return air filters with tool-less filter access door
- Belt drive evaporator-fan motor and pulley combinations available on all sizes to meet any application
- Direct Drive ECM - indoor motor is standard with optional belt drive systems
- New terminal board facilitating simple safety circuit troubleshooting and simplified control box arrangement

INSTALLATION FEATURES

- Thru-the-bottom power entry capability standard
- Single point electric connections
- Full perimeter base rail with built-in rigging adapters & fork truck slots



Use of the AHRI Certified TM Mark indicates a manufacturer's participation in the program. For verification of certification for individual products, go to www.ahridirectory.org.



RELIABILITY FEATURES

- Scroll compressors with internal line break overload protection
- Dependable Time / Temperature defrost board and logic
- 24-volt control circuit protected with resettable circuit breaker
- Permanently lubricated evaporator-fan motor
- Totally enclosed condenser motors with permanently lubricated bearings
- Loss of charge, freeze protection, and high-pressure switches

FACTORY OPTIONS INCLUDING BUT NOT LIMITED TO:

- 115-volt convenience outlet (Non-powered)
- Non-fused disconnect switch
- Supply air smoke detector
- Economizer with db, enthalpy or CO₂ control options
- Corrosion resistant coil options for evaporator and condenser
- Multiple indoor fan motors for expanded airflow capability (3 ph)
- Accessory electric heat (field-installed option only)
- Integrated economizer system. Standard and Ultra Low leak versions available.

LIMITED WARRANTY *

- 5 year compressor limited warranty
- 1 year parts limited warranty

* See warranty certificate for complete details and restrictions

UNIT PERFORMANCE DATA									
BASE MODEL	Nominal Tons	COOLING			HEATING			Unit Dimensions H x W x L in. (mm)	Unit Weight lbs (kg)
		Net Cap. (Btuh)	SEER	EER	High Cap. (Btuh)	HSPF	COP		
RHX036*0XA0AAA	3	35,600	14.00	12.10	35,600	8.10	N/A	33-3/8 x 46-3/4 x 74-3/8 (847 x 1187 x 1888)	495 (224)
RHX048*0XA0AAA	4	49,000	14.00	12.10	45,500	8.00	N/A	41-3/8 x 46-3/4 x 74-3/8 (1051 x 1187 x 1888)	580 (263)
RHX060*0XA0AAA	5	58,000	14.30	12.20	58,000	8.20	N/A	41-3/8 x 46-3/4 x 74-3/8 (1051 x 1187 x 1888)	610 (276)

* Indicates Unit voltage: K = 208/230-1-60, H = 208/230-3-60, L = 460-3-60, S = 575-3-60

Specifications subject to change without notice.

**SEE PRODUCT SPECIFICATIONS OR
ACCESSORY USAGE GUIDE
FOR COMPLETE LIST OF
ACCESSORIES AVAILABLE BY MODEL**