

TSM Integrated Step-Servo



- **Multi-axis field bus control**
- **Intelligent built-in controller**
- **Compact all-in-one solution**
- **Efficient, smooth, accurate & fast**
- **Enhanced motor optimized design**



Sold & Serviced By:



Toll Free Phone (877) SERV098

Toll Free Fax (877) SERV099

www.electromate.com

sales@electromate.com



The **Step-Servo** is an innovative revolution for the world of motion control; it enhances the stepper motors with servo technology to create a product with exceptional features and broad capabilities.

TSM is Applied Motion Products' integrated **Step-Servo** compact motor+drive+encoder+controller all-in-one solution.

Multi-functional Capability

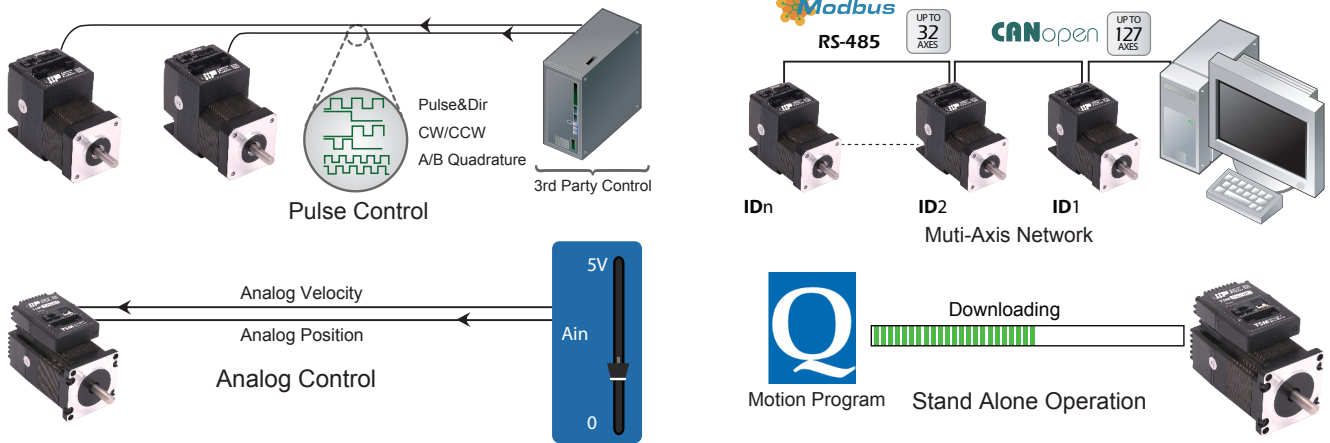

Closed Loop

- High accuracy position and velocity control for the most demanding applications.
- Robust servo loops that tolerate wide fluctuation in load inertia and frictional loading.
- Precise positioning to within ± 1 count (0.018°) using high resolution (20,000 counts/rev) encoder.

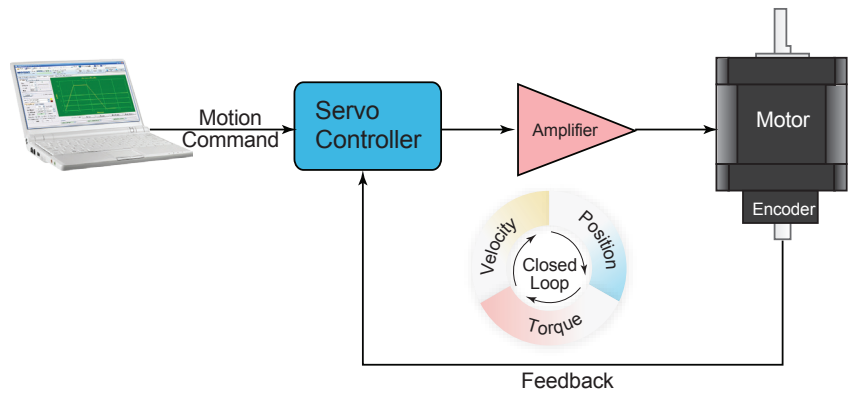

Low Heating/High Efficiency

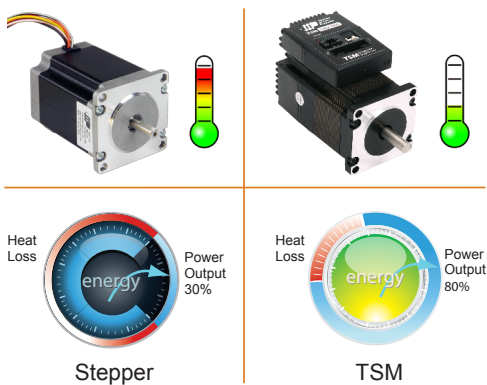

- Uses only the current required by the application, generating minimum heat output.
- When at stand-still, the current can reach nearly zero for extremely low heat output.
- Being able to use all available torque allows for more efficient and compact motor usage.

Smooth & Accurate

- Space vector current control with 5000 line high resolution encoder gives smooth and quiet operation, especially at low speeds
 - A feature never found with traditional stepping motors
- High stiffness due to the nature of the stepping motor combined with the highly responsive servo control
 - Accurate position control both while running and static positioning

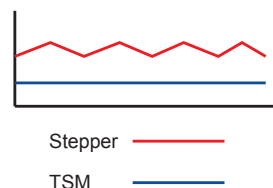

Sold & Serviced By:
ELECTROMATE
 Toll Free Phone (877) SERV098
 Toll Free Fax (877) SERV099
 www.electromate.com
 sales@electromate.com

Fast Response

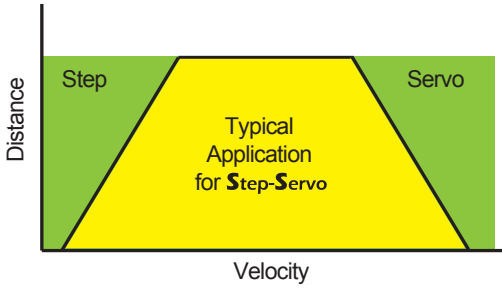

- When performing fast point-to-point moves, the high torque output and advanced servo control provides a very responsive system far exceeding what can be done with a conventional stepper system.

High Torque

- Because the TSM operates in full servo mode, all the available torque of the motor can be used. The motor can provide as much as 50% more torque in many applications. High torque capability often eliminates the need for gear reduction.
- Boost torque capability can provide as much as 50% more torque for short, quick moves.

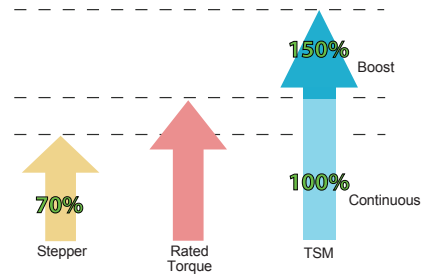

Motion Monitoring

- For difficult control situations where performing a precise move is necessary, the **Step-Servo Quick Tuner** provides an easy to use interface for performing and monitoring the motion profile.
- Many common parameters such as Actual Speed or Position Error can be monitored to evaluate system performance.
- The monitoring is interactive with the servo tuning capability so that optimum performance can be achieved.

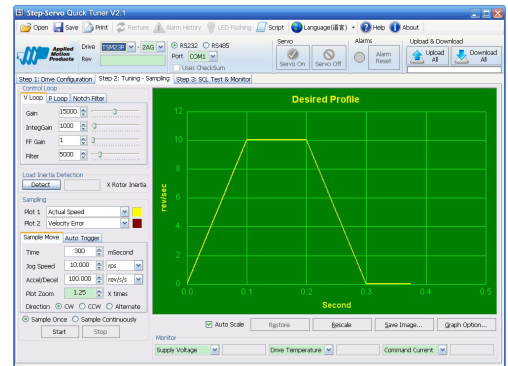

Easy Tuning

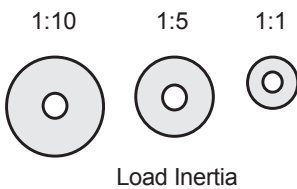

- Pre-defined tuning parameters for maximum control performance and stability.
- Easy selection list provides the level of control desired.
- In most cases NO extra manual tuning is required.

Key Enhancements Based on the SSM Family

- Up to 8 digital inputs, 4 digital outputs and 1 analog inputs for S/Q/C type
- A/B/Z differential encoder signal output supported for P type
- Automatic load inertia detection
- On board daisy chain connection for field bus control(RS-485, **Modbus/RTU, CANopen**)
- Multiple homing features for S/Q type
- Software limit for S/Q type
- Built-in position table up to 63 points for S type

Sold & Serviced By:



Toll Free Phone (877) SERV098
 Toll Free Fax (877) SERV099
 www.electromate.com
 sales@electromate.com

Step-Servo Quick Tuner

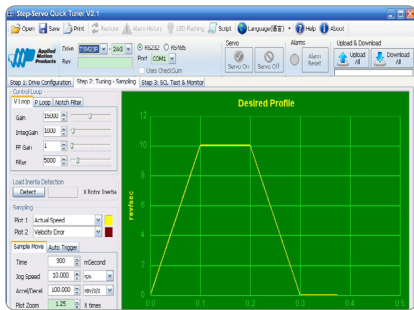

Features

- Friendly interface
- Easy setup in just three steps
- Drive setup and configuration
- Servo tuning and sampling
- Motion testing and monitoring
- Write and save SCL command scripts
- Integrated online help

Built-in Q Programming

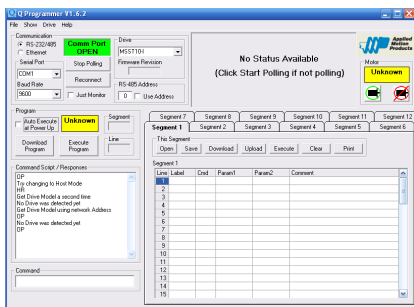

Features

- Single-axis motion control
- Stored program execution
- Multi-tasking
- Conditional processing
- Math functions
- Data registers
- Motion profile simulation
- Integrated online help

RS485 Bus Utility

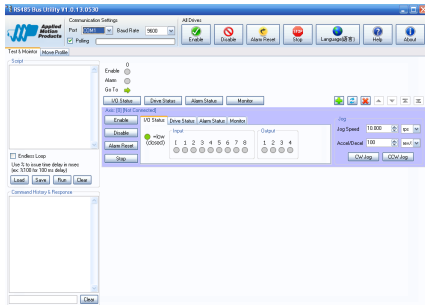

Features

- Stream SCL commands from the command line
- Simple interface with powerful capability
- Easy setup with RS-485 for 32 axis network motion control
- Monitoring status of I/O, drive, alarm and the other parameters
- Useful motion parameters
- Write and save SCL command scripts
- Integrated online help
- Supports all RS-485 drives

CANopen Test Tool

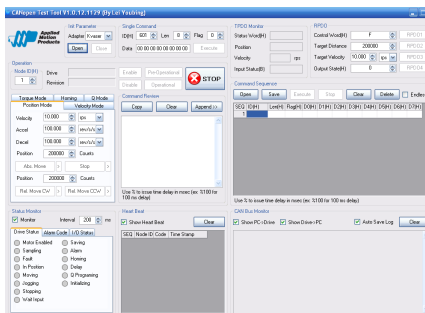

Features

- Friendly User Interface
- Multiple operation mode support
- Multi-thread, high performance
- CAN bus monitor and log history function
- Kvaser/PEAK/ZLG adapter support

FREE DOWNLOAD
 Our software and user manual can be downloaded from our website:
www.applied-motion.com

All software applications run on Windows 7 or 8, Vista, XP, 32-bit or 64-bit



Toll Free Phone (877) SERV098
 Toll Free Fax (877) SERV099
www.electromate.com
sales@electromate.com

◇ **-P Pulse Input Type**

Controlled via pulse generator, indexer or motion controller.

Main Features

- Accepts three types of pulse signal input as Pulse&Direction, CW/CCW and A/B Quadrature
- Encoder signal output, A/B/Z differential

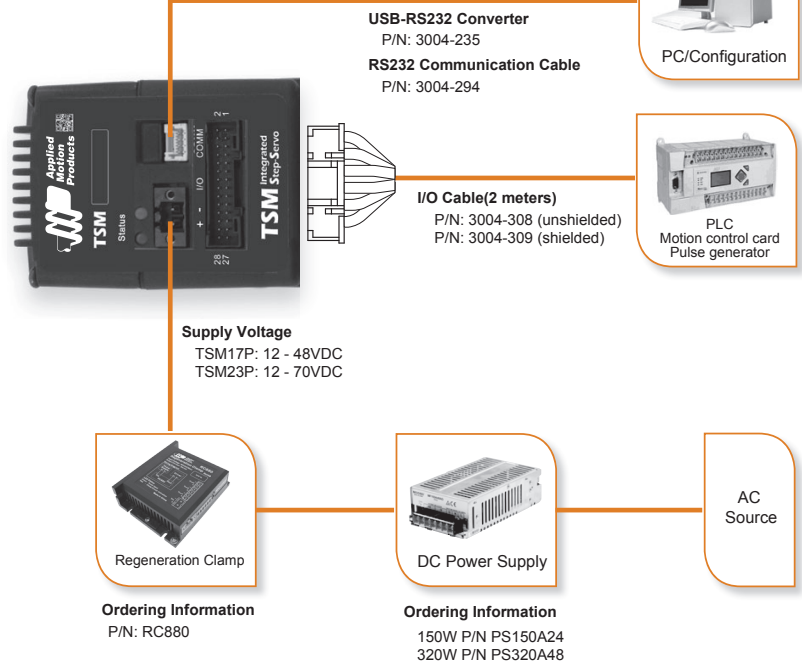

◇ **-S Basic Type with Serial Communication**

Controlled via pulse signals, analog signal or Applied Motion Products SCL streaming serial commands.

Main Features

- Pulse control
- Analog control
- Host real time control using SCL via RS-232/RS-485
- Up to 32 axes per channel for RS-485
- Position Table (up to 63 points selected by digital inputs)

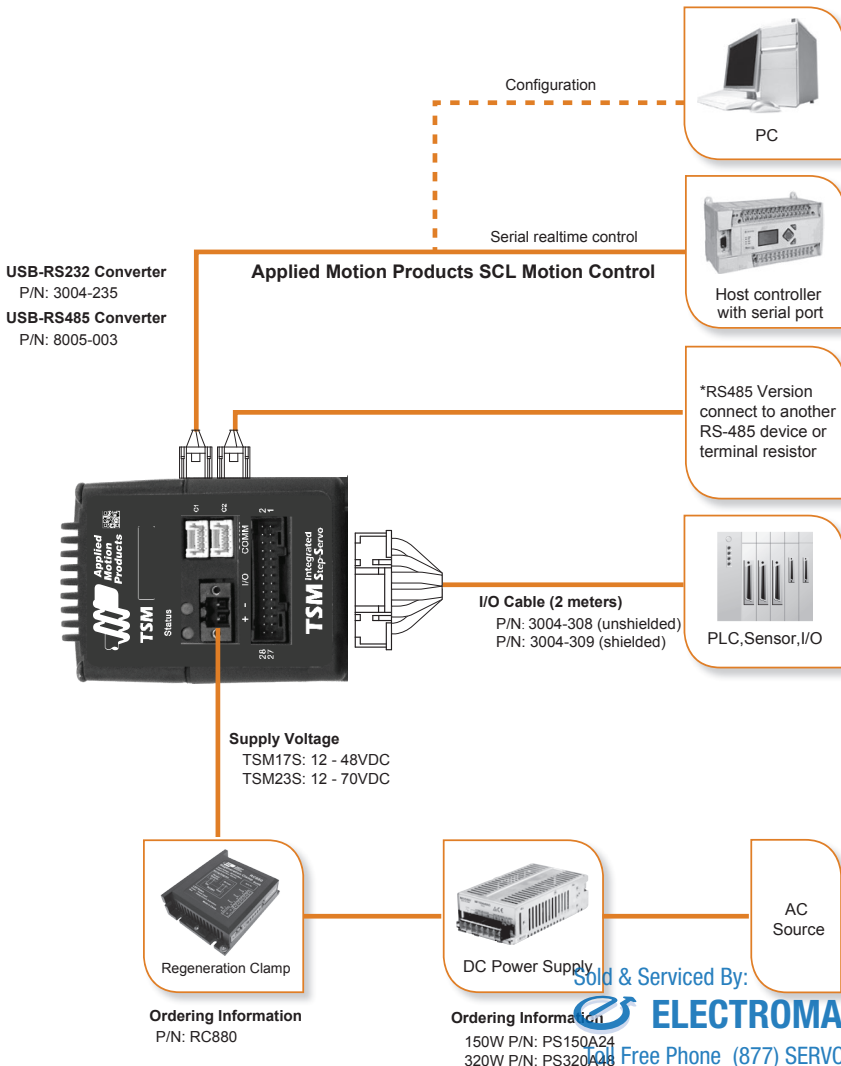

◇ **-Q Built-in Programmable Motion Controller (Includes Modbus/RTU Type)**

Run stand-alone, stored programs. Commands for controlling motion, inputs & outputs, drive configuration and status, as well as math operations, register manipulation, and multi-tasking.

Main Features

- Stand-alone operation plus Serial host control
- Math operations
- Register manipulation
- Multi-tasking
- With all features in S type
- **Modbus/RTU** network, up to 32 axes per channel

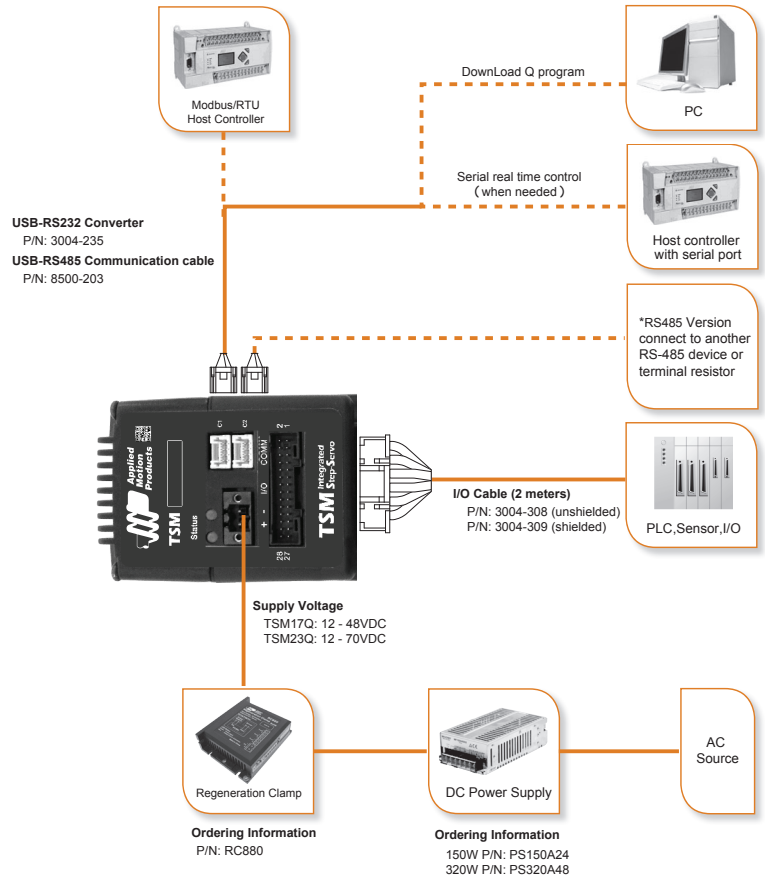

Ordering Information
P/N: RC880



Ordering Information
150W P/N: PS150A24
320W P/N: PS320A48



AC Source

Supply Voltage
TSM17C: 12 - 48VDC
TSM23C: 12 - 70VDC
TSM24C: 12 - 70VDC



I/O Cable (2 meters)
P/N: 3004-308 (unshielded)
P/N: 3004-309 (shielded)



PLC, Sensor, I/O

Connect to another CANopen slave node or terminal resistor



Download Q program via RS-232



CIA301 CANopen

USB-CAN Converter
P/N: MS-USB-CAN Couverter

◇ **-CANopen Type**

Operates on a **CANopen** communication network and conforms to CiA301 and CiA402. It supports running stored Q programs via Applied Motion Products-specific **CANopen** objects.

Main Features

- **CANopen** network
- Up to 127 axes per channel
- Objects for Q programming

■ **Frame size 42mm**

Model	Pulse input type	TSM17P-1AG	TSM17P-2AG	TSM17P-3AG
	Basic type	TSM17S-1□G	TSM17S-2□G	TSM17S-3□G
	Q program type (Includes Modbus/RTU type)	TSM17Q-1□G	TSM17Q-2□G	TSM17Q-3□G
	CANopen type	TSM17C-1CG	TSM17C-2CG	TSM17C-3CG
Holding Torque	N·m	0.28	0.42	0.52
Rotor Inertia	g·cm ²	38	57	82
Supply Voltage	VDC	12-48		
Encoder Resolution	counts/rev	20000	20000	20000
Maximum Speed	RPM	3600	3600	3600
Mass	g	280	360	440

Enter A(RS232) or R(RS485) in the box(□) within the model name

◇ **Torque Curves**

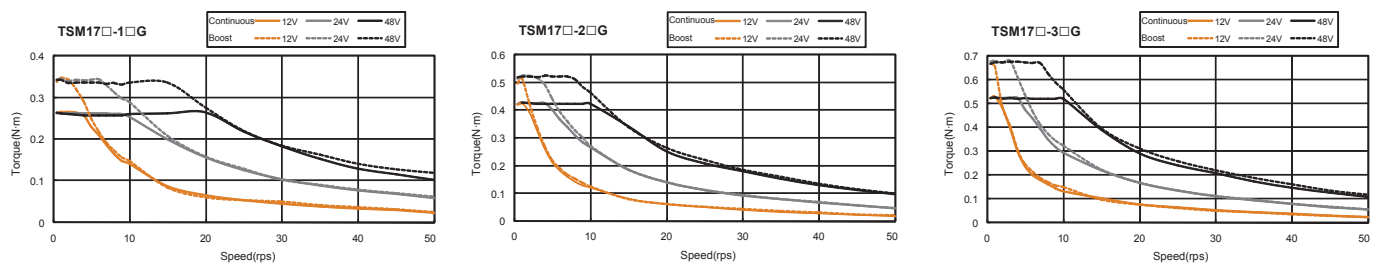

◇ **Electrical Specifications**

	Pulse input type TSM17P-■AG	Basic type TSM17S-■□G	Q program type TSM17Q-■□G	CANopen type TSM17C-■CG
Control Command	Pulse input	Pulse input Analog signal Position table SCL	Pulse input Analog signal SCL Q Program Modbus/RTU	Q program CANopen
Pulse signal type	Pulse+Direction CW/CCW Pulse A/B Quadrature	Pulse+Direction CW/CCW Pulse A/B Quadrature	Pulse+Direction CW/CCW Pulse A/B Quadrature	-
Maximum Input Pulse Frequency	2MHz, Minimum Pulse Width=250ns	2MHz, Minimum Pulse Width=250ns	2MHz, Minimum Pulse Width=250ns	-
Digital Input	4	8	8	8
Digital Output	3	4	4	4
Analog Input	-	1	1	1
Encoder Output	20,000 counts/rev A/B/Z Differential	-	-	-
Digital Input Specification	Optical Isolated 5-24VDC			
Digital Onput Specification	Optical Isolated 30VDC/100mA			
Analog Input Specification	AIN referenced to GND, Range 0-5VDC, Resolution:12bits			
Supply Voltage	12-48VDC			
Protection	Over-voltage, under-voltage, over-temp, motor/wiring shorts (phase-to-phase, phase-toground)			
Comunication	RS-232	RS-232 or RS-485	RS-232 or RS-485	RS-232&CANopen
Protocol	-	SCL	Modbus/RTU or SCL	CANopen

Enter motor length 1,2,3 in the box(■) within the model name

Enter A(RS232) or R(RS485) in the box(□) within the model name

Sold & Serviced By:



Toll Free Phone (877) SERV098

Toll Free Fax (877) SERV099

www.electromate.com

sales@electromate.com

■ **Frame size 56mm**

Model	Pulse input type	TSM23P-2AG	TSM23P-3AG	TSM23P-4AG
	Basic type	TSM23S-2□G	TSM23S-3□G	TSM23S-4□G
	Q program type (Includes Modbus/RTU type)	TSM23Q-2□G	TSM23Q-3□G	TSM23Q-4□G
	CANopen type	TSM23C-2CG	TSM23C-3CG	TSM23C-4CG
Holding Torque	N·m	1.0	1.5	2.4
Rotor Inertia	g·cm ²	260	460	490
Supply Voltage	VDC	12-70		
Encoder Resolution	counts/rev	20000	20000	20000
Maximum Speed	RPM	3600	3600	3600
Mass	g	850	1200	1400

Enter A(RS232) or R(RS485) in the box(□) within the model name

◇ **Torque Curves**

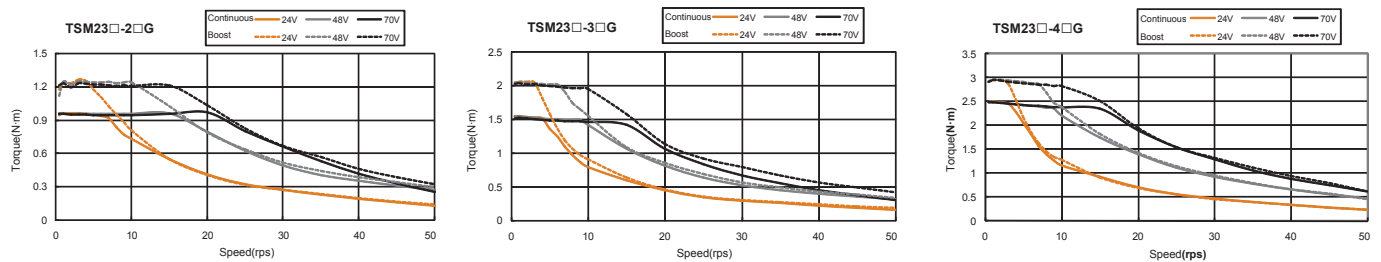

◇ **Electrical Specifications**

	Pulse input type TSM23P-■AG	Basic type TSM23S-■□G	Q program type TSM23Q-■□G	CANopen type TSM23C-□CG
Control Command	Pulse input	Pulse input Analog signal Position table SCL	Pulse input Analog signal SCL Q Program Modbus/RTU	Q program CANopen
Pulse signal type	Pulse+Direction CW/CCW Pulse A/B Quadrature	Pulse+Direction CW/CCW Pulse A/B Quadrature	Pulse+Direction CW/CCW Pulse A/B Quadrature	-
Maximum Input Pulse Frequency	2MHz, Minimum Pulse Width=250ns	2MHz, Minimum Pulse Width=250ns	2MHz, Minimum Pulse Width=250ns	-
Digital Input	4	8	8	8
Digital Output	3	4	4	4
Analog Input	-	1	1	1
Encoder Output	20,000 counts/rev A/B/Z Differential	20,000 counts/rev A/B/Z Differential	20,000 counts/rev A/B/Z Differential	-
Digital Input Specification	Optical Isolated 5-24VDC			
Digital Onput Specification	Optical Isolated 30VDC/100mA			
Analog Input Specification	AIN referenced to GND, Range 0-5VDC, Resolution: 12bits			
Supply Voltage	12-70VDC			
Protection	Over-voltage, under-voltage, over-temp, motor/wiring shorts (phase-to-phase, phase-toground)			
Communication	RS-232	RS-232 or RS-485	RS-232 or RS-485	RS-232&CANopen
Protocol	-	SCL	Modbus/RTU or SCL	CANopen

Enter motor length 2,3 or 4 in the box(■) within the model name

Enter A(RS232) or R(RS485) in the box(□) within the model name

Sold & Serviced By:



Toll Free Phone (877) SERV098

Toll Free Fax (877) SERV099

www.electromate.com

sales@electromate.com

■ RS485 or Modbus/RTU Specifications

Interface	RS485 or Modbus/RTU
Baud Rate(bps)	9600/19200/38400/57600/115200
Maximum Distance	Due to transmission baud rate
Maximum Connections	32 axes per channel
Communication Cable	Twisted Shielded Cable
Address Setting	Via Step-Servo Quick Tuner

■ CANopen Specifications

Interface	CANopen CiA301 CiA402
Bit Rate(bps)	1M/800K/500K/250K/125K/50K/20K/12.5K
Maximum Distance	Due to transmission bit rate
Maximum Slave Nodes	127 axes per channel
Communication Cable	Twisted Shielded Cable
Node ID Setting	On Board Rotary Switch: Lower 4 bits 0H-FH Step-Servo Quick Tuner: Upper 3 bits 00H-7FH

■ General Specifications

		TSM Integrated Step-Servo
Insulation Class		Class B(130°C)
Insulation Resistance		100MΩ/DC500V
Dielectric Strength		500VAC 1 minute
Operating Environment	Ambient Temperature	0~+40°C(non-freezing)
	Ambient Humidity	90% or less(non-condensing)
	Atmosphere	No corrosive gases, dust, water or oil
Degree of Protection		IP20

■ Permissible Overhung Load and Permissible Thrust Load (Unit:N)

Frame Size	Model	Permissible Overhung Load Distance(L) from Shaft End(mm)					Permissible Thrust Load
		0	5	10	15	20	
42mm	TSM17□-1□G	35	44	58	85	-	Less than the motor mass
	TSM17□-2□G						
	TSM17□-3□G						
56mm	TSM23□-2□G	63	75	95	130	190	
	TSM23□-3□G						
	TSM23□-4□G						

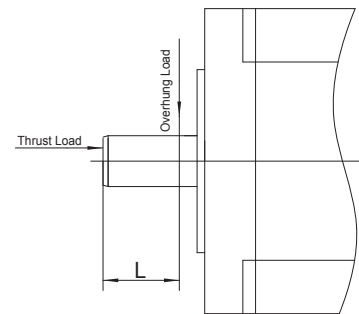

■ Dimensions (Unit:mm)

TSM17

Model	"L"	"M"
TSM17□-1□G	69.5	26.6
TSM17□-2□G	75	32.1
TSM17□-3□G	83.5	40.6

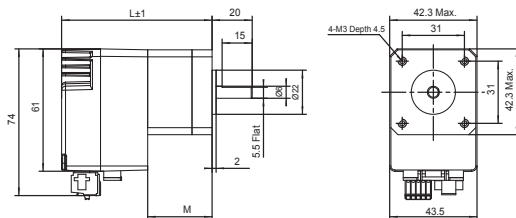

* 5 mm diameter shaft available per request.

TSM23

Model	"L"	"M"
TSM23□-2□G	95.6	24.6
TSM23□-3□G	117.6	46.6
TSM23□-4□G	120.6	49.9

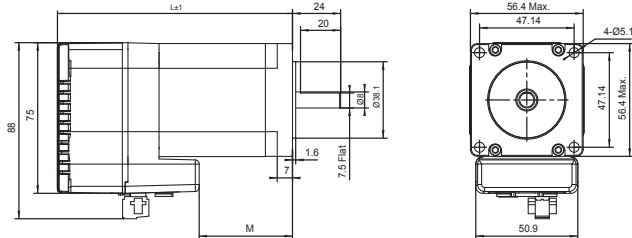

* 6.35 mm diameter shaft available per request.

Sold & Serviced By:



Toll Free Phone (877) SERV098

Toll Free Fax (877) SERV099

www.electromate.com

sales@electromate.com

Optional Accessories

P/N	Category	Technical Specification
PS150A24	Switching power supplier	150W, 24V
PS320A48	Switching power supplier	320W, 48V
RC880	Regeneration Clamp	80VDC Max. 50W
3004-235	USB Converter	USB-RS232
8005-003	USB Converter	USB-RS485
3004-308-□M	Cable	I/O cable, unshielded
3004-309-□M	Cable	I/O cable, shielded
3004-294	Cable	RS232 communication cable
3004-310-□M	Cable	RS485 Daisy Chain
3004-311-□M	Cable	CANopen Daisy Chain

* □□□ stands for length, unit:cm, ex.1M stands for 1 meter

Switching Power Supplies

Applied Motion Products recommends the following switching power supplies

P/N:PS150A24 150W, 24VDC

P/N:PS320A48 320W, 48VDC

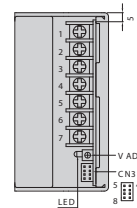
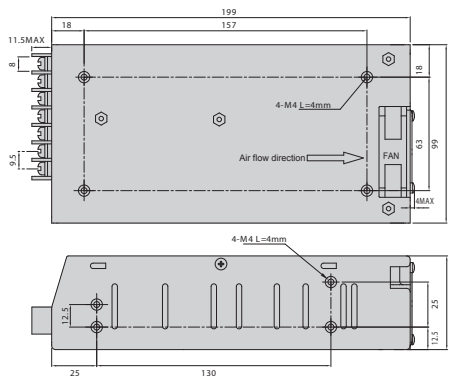
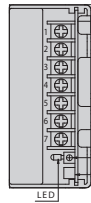
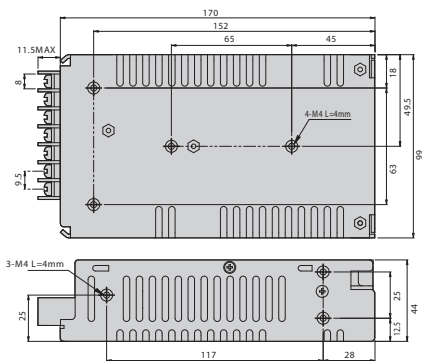

Regeneration Clamp

P/N: RC880

When using a regulated power supply you may encounter a problem with regeneration. Regeneration occurs when the kinetic energy of the motor and load is transferred back to the power supply during deceleration. This can trip the overvoltage protection of a switching power supply, causing it to shut down.

Applied Motion Products offers the RC880 “regeneration clamp” to solve this problem. If in doubt, use an RC880 for your first installation. If the “regen” LED on the RC880 never flashes, you don’t need the clamp.

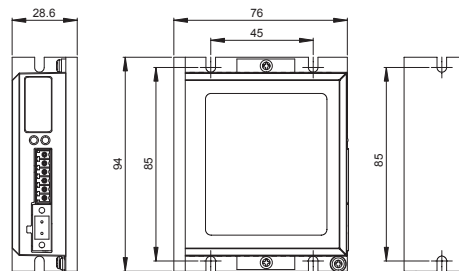

USB Converter

Model: 3004-235
Description: USB-RS232 converter

Model: 8005-003
Description: USB-RS485 converter

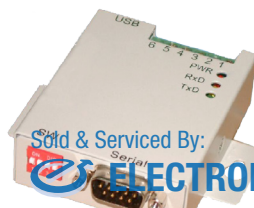

Sold & Serviced By:
ELECTROMATE
Toll Free Phone (877) SERV098
Toll Free Fax (877) SERV099
www.electromate.com
sales@electromate.com

◇ General Purpose I/O Cable (unshielded)

P/N	Length
3004-308-1M	1m
3004-308-2M	2m
3004-308-5M	5m

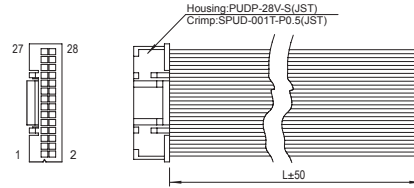

Pin No.	Assignment	Description	Color	Pin No.	Assignment	Description	Color
1	X1+	High Speed Digital Input	BLU	15	X8+	X8 Digital Input	GRN
2	X1-		BLU/WHT	16	X8-		GRN/WHT
3	X2+	High Speed Digital Input	YEL	17	Y1	Y1 Digital Input	BLU
4	X2-		YEL/WHT	18	Y2	Y2 Digital Input	YEL
5	X3	X3 Digital Input	GRN	19	Y3	Y3 Digital Input	BRN
6	X4	X4 Digital Input	ORG	20	YCOM	Y Output COM	BLK
7	X5	X5 Digital Input	GRY	21	Y4+	Y4 Digital COM	RED
8	X6	X6 Digital Input	PPL	22	Y4-		RED/WHT
9	XCOM	X Digital Input COM	WHT	23	Z+	Encoder Output Z (if applicable)	BLK
10	+5V	+5V Analog Voltage	RED	24	Z-		BLK/WHT
11	AIN	Analog Input	BLU	25	B+	Encoder Output B (if applicable)	GRN
12	GND	Analog Input Ground	BLK	26	B-		GRN/WHT
13	X7+	X7 Digital Input	ORG	27	A+	Encoder Output A (if applicable)	ORG
14	X7-		ORG/WHT	28	A-		ORG/WHT

◇ General Purpose I/O Cable (shielded)

P/N	Length
3004-309-1M	1m
3004-309-2M	2m
3004-309-5M	5m

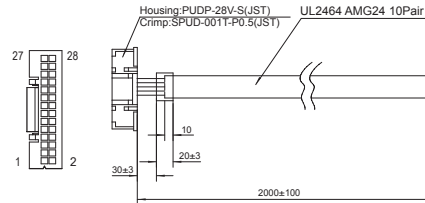

Pin No.	Assignment	Description	Color	Pin No.	Assignment	Description	Color
1	X1+	High Speed Digital Input	BLK	15	NC		
2	X1-		RED	16	NC		
3	X2+	High Speed Digital Input	BLK	17	Y1	Y1 Digital Output	BLK
4	X2-		WHT	18	Y2	Y2 Digital Output	BRN
5	X3	X3 Digital Input	BLK	19	Y3	Y3 Digital Output	BLK
6	X4	X4 Digital Input	GRN	20	YCOM	Y Output COM	ORG
7	NC			21	NC		
8	NC			22	NC		
9	XCOM	X Input COM	BLK	23	Z+	Encoder Output Z (if applicable)	RED
10	+5V	+5V Analog Voltage	BLU	24	Z-		WHT
11	AIN	Analog Input	BLK	25	B+	Encoder Output B (if applicable)	RED
12	GND	Analog Input Ground	YEL	26	B-		GRN
13	NC			27	A+	Encoder Output A (if applicable)	RED
14	NC			28	A-		BLU

◇ RS485 Daisy Chain Communication Cable

P/N	Length
3004-310-0.5M	0.5m
3004-310-1M	1m
3004-310-3M	3m
3004-310-5M	5m

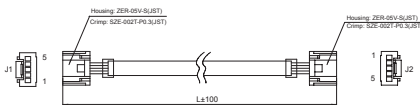

◇ CANopen Daisy Chain Communication Cable

P/N	Length
3004-311-0.5M	0.5m
3004-311-1M	1m
3004-311-3M	3m
3004-311-5M	5m

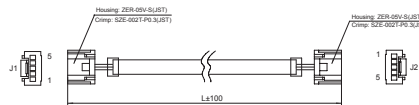

◇ RS232 Communication Cable (P/S/Q Type)

P/N	Length
3004-294	1.5m

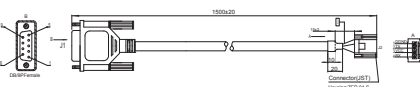

◇ RS232 Communication Cable (C Type)

P/N	Length
3004-296	1.5m

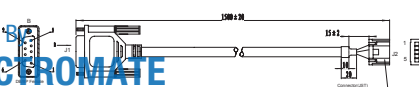

Toll Free Phone (877) SERV098
 Toll Free Fax (877) SERV099
 www.electromate.com
 sales@electromate.com

■ Numbering System



TSM 17 S-2 A G

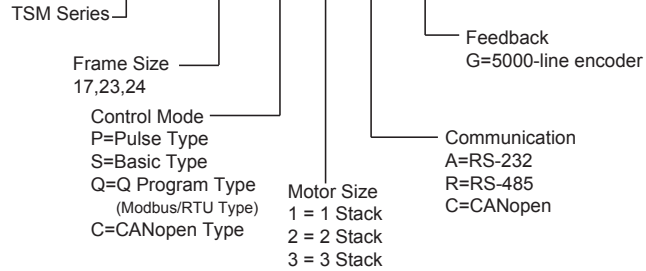

■ Ordering Information

Model	Torque	Control	I/O(*)	RS-232	RS-485	Modbus/RTU	CANopen	Model	Torque	Control	I/O(*)	RS-232	RS-485	Modbus/RTU	CANopen	
TSM17P-1AG	0.28N-m	P	4DI,3DO,EO	✓				TSM23P-2AG	1.0N-m	P	4DI,3DO,EO	✓				
TSM17S-1AG		S	8DI,4DO,1AI	✓				TSM23S-2AG		S	8DI,4DO 1AI,EO	✓				
TSM17S-1RG					✓			TSM23S-2RG						✓		
TSM17Q-1AG		Q	8DI,4DO,1AI	✓		✓		TSM23Q-2AG		Q			✓		✓	
TSM17Q-1RG						✓	✓	TSM23Q-2RG					✓	✓		
TSM17C-1CG		C	8DI,4DO,1AI	✓				✓		TSM23C-2CG	C	8DI,4DO,1AI	✓			✓
TSM17P-2AG	0.42N-m	P	4DI,3DO,EO	✓				TSM23P-3AG	1.5N-m	P	4DI,3DO,EO	✓				
TSM17S-2AG		S	8DI,4DO,1AI	✓				TSM23S-3AG		S	8DI,4DO 1AI,EO	✓				
TSM17S-2RG					✓			TSM23S-3RG						✓		
TSM17Q-2AG		Q	8DI,4DO,1AI	✓		✓		TSM23Q-3AG		Q			✓		✓	
TSM17Q-2RG						✓	✓	TSM23Q-3RG					✓	✓		
TSM17C-2CG		C	8DI,4DO,1AI	✓				✓		TSM23C-3CG	C	8DI,4DO,1AI	✓			✓
TSM17P-3AG	0.52N-m	P	4DI,3DO,EO	✓				TSM23P-4AG	2.4N-m	P	4DI,3DO,EO	✓				
TSM17S-3AG		S	8DI,4DO,1AI	✓				TSM23S-4AG		S	8DI,4DO 1AI,EO	✓				
TSM17S-3RG					✓			TSM23S-4RG						✓		
TSM17Q-3AG		Q	8DI,4DO,1AI	✓		✓		TSM23Q-4AG		Q			✓		✓	
TSM17Q-3RG						✓	✓	TSM23Q-4RG					✓	✓		
TSM17C-3CG		C	8DI,4DO,1AI	✓				✓		TSM23C-4CG	C	8DI,4DO,1AI	✓			✓

Sold & Serviced By

 Toll Free Phone: (877) SERV098
 Toll Free Fax: (877) SERV099

* DI: Digital Input; DO: Digital Output; EO: Encoder Output; AI: Analog Input

www.electromate.com
sales@electromate.com