

Electric Lift, Mobile Stand

DESIGNED FOR 55" WEBEX® BOARD PRO

FPS SERIES



55" Cisco Webex Pro Electric Lift – Graphite
FPS1/EL/CSP55/GG



55" Cisco Webex Pro Electric Lift – White
FPS1/EL/CSP55/VW

Take control of creative, presentation and collaboration work spaces. Salamander's beautiful and highly functional FPS Series Mobile Stands offer superior ergonomics complimenting any touch screen display with improved productivity, unrivaled flexibility and lifetime value.

A stylish, sleek and compact design moves easily between spaces. A thoughtful range of accessories provides even more utility and an improved user experience.

- Mobile stand for interactive display / touchscreen panel
- Motorized Electric Lift and wired remote
- ADA Compliant
- Ergonomic design. Adjustable height positioning provides best possible ergonomics and viewing
- Superior mobility. High quality commercial grade locking casters and integrated handles provide easy maneuverability and transport
- Fully concealed cable management allows clean and uncluttered installation
- Range of travel, Center of screen : Min- 36.83" (935.5 mm) and Max 62.42" (1585.5 mm)
- Storage for electronic components, peripherals and accessories
- Telescopic design allows compact position for transport and storage
- Durable construction. Made in USA of powder coated steel, Linak Motor components, Powder coated and/or veneered MDF panels
- Options available for peripheral equipment mounting, retractable cable reel, secure equipment storage cover, keyboard tray and more
- Limited Lifetime Warranty

Electric Lift, Mobile Stand

DESIGNED FOR 55" WEBEX® BOARD PRO

FPS SERIES
FPS1/EL/CSP55/GG

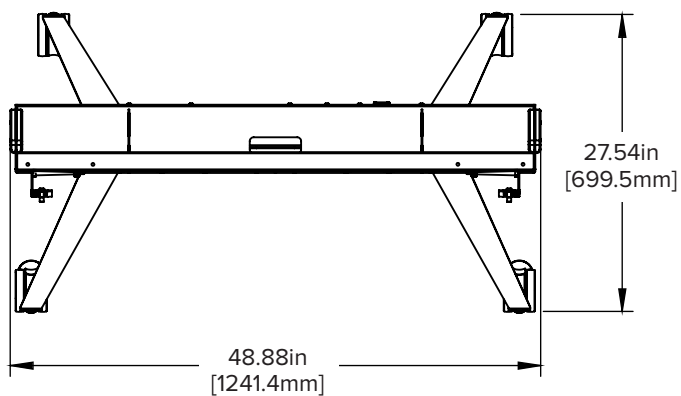
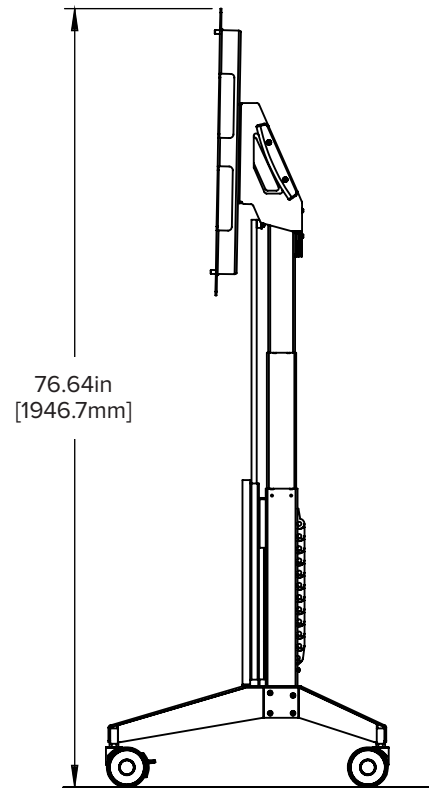
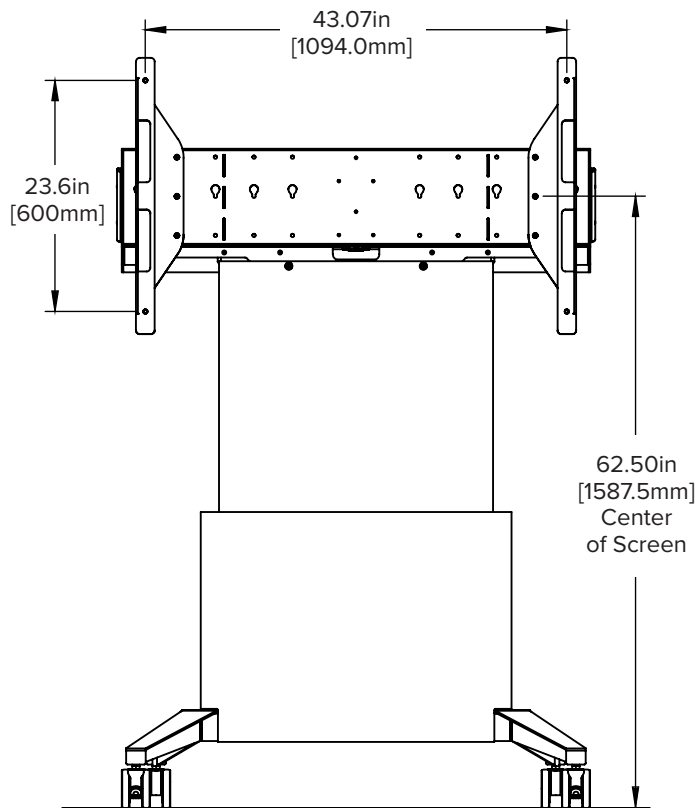

Electric Lift, Mobile Stand

DESIGNED FOR 55" WEBEX® BOARD PRO

FPS SERIES
FPS1/EL/CSP55/GG

PRODUCT SPECIFICATIONS	Metric (mm)	US/Imperial Inches	SHIPPING DIMENSIONS	
	Length	1215.2	47.84	1,219 mm
Overall Height Range	1146.6 - 1796.6	45.14 - 70.7	1,016 mm	40 inch
Center of Screen Range of Travel	935.83 - 1585.5	36.83 - 62.42		
Depth	695.4	27.38	406 mm	16 inch
Weight	61.23 kg	135 lbs	72.57 kg	160 lbs
Max Load Capacity	79.38 kg	175 lbs		
UPC Number	634878507110			

Caster Wheels

4" (100mm) HD, Non Marking, Brakes on 2

Electrical Information

Input: 90V - 240V ~, 48 Hz - 63HZ
Duty Cycle: 10% Max 2min / 18min

Cable Manager Chain

1" x .75" x 34" (25 x 19 x 865mm)

Power Cable

IEC - Type Class 2, 2-prong
USA Included: (PN 400-590)

International Power Cables Available:

EU (PN 400-591)
UK (PN 400-592)
New Zealand, Australia and others (PN 400-593)

Electric Lift, Mobile Stand

DESIGNED FOR 55" WEBEX® BOARD PRO

FPS SERIES
ACCESSORIES

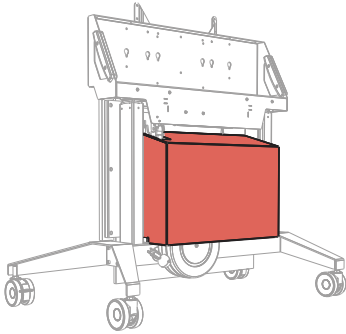

**Equipment Storage
Cover- Graphite**
FPSA/SC/GT

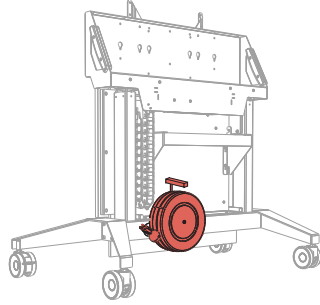

Cable Reel 30' Payout, 24"
Tri-Tap Female End
FPSA/CR

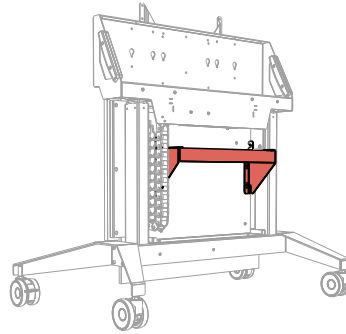

19" Rack Mounting 3 RU
RM/VR/3U

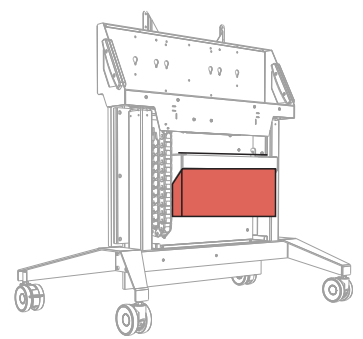

Power Distribution Unit
SA/RM/PDU

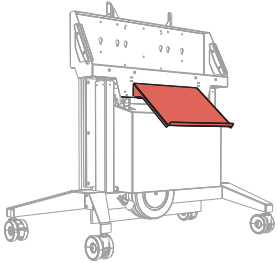

**Keyboard Storage
Shelf- Graphite**
FPSA/KS/GT

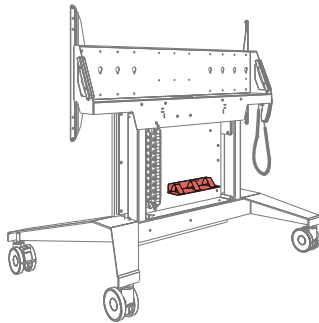

**Accessory Shelf
with Straps**
FPSA/AS1

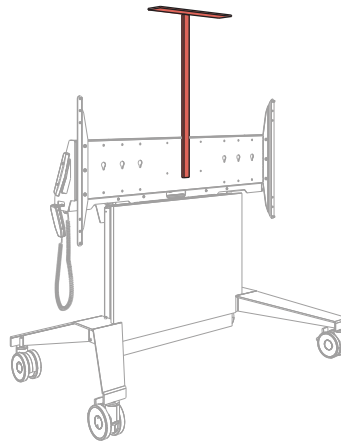

Tech Shelf
FPSA/CS

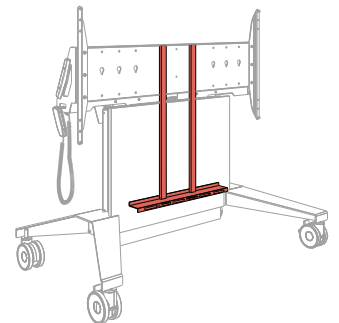

Tech Bracket Kit
FPSA/SBK

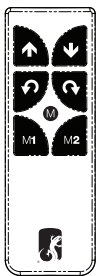

**Wireless RF Remote
Control with Memory**
FPSA/RF1

ROAD CASE

FOR EASY DEPLOYMENT

Combine a mobile stand with a road case to provide secure and convenient transport of your display.

Accommodates Stand & Display

FPSA/RC/EL

