

Overview

Introduction

HP Notebook Stands include a range of convenient solutions and space-saving designs that easily connect to your HP Business Notebook and enable easy viewing and an ideal desktop computing environment.

Models

HP Adjustable Dual Display Stand	AW664AA
HP Display and Notebook Stand	AW662AA
HP Dual Hinge Notebook Stand	AW661AA
HP Adjustable Display Stand	AW663AA
HP LCD Monitor Stand	QM196AA
HP Single Monitor Arm	BT861AA

HP Adjustable Dual Display Stand (AW664AA)

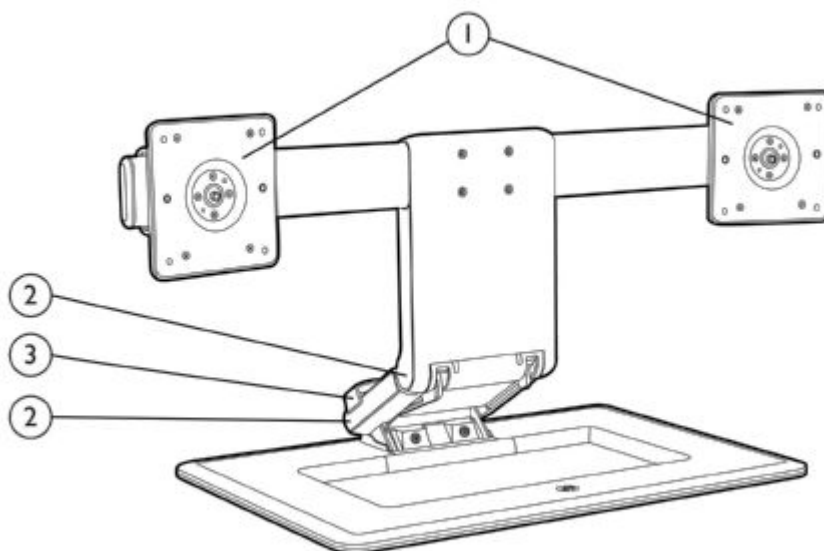

1. VESA display mounts
2. Dual-hinged display stand
3. Cable management channel

HP Display and Notebook Stand (AW662AA)

Overview

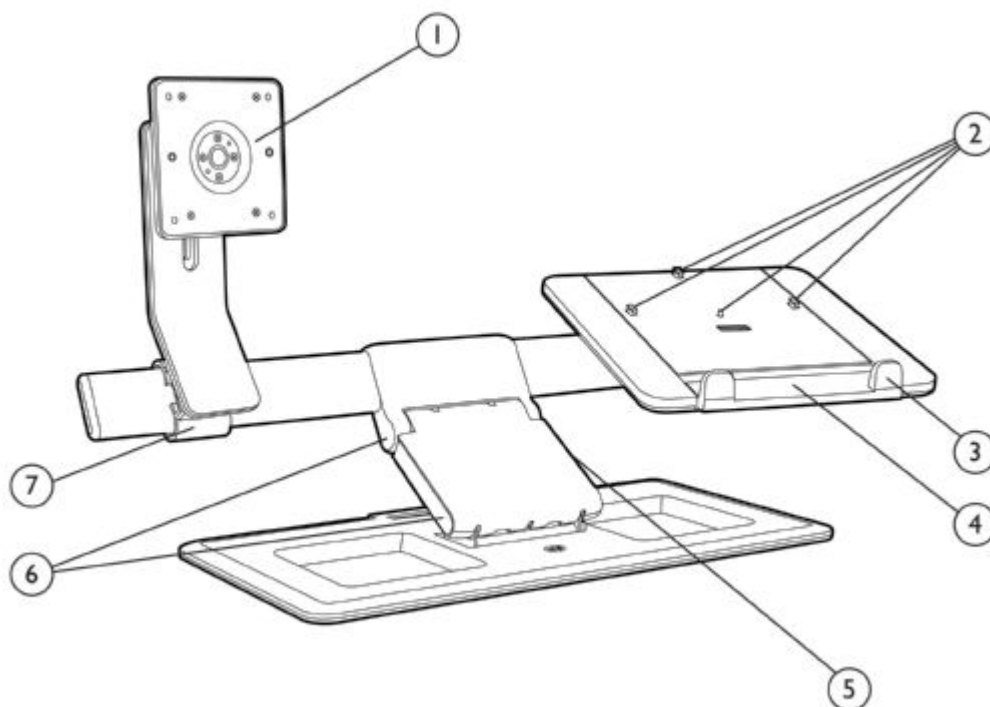

- 1. VESA display mounts
- 2. Docking posts
- 3. Adjustable shelf
- 4. Notebook platform
- 5. Cable management channel (not shown)
- 6. Dual-hinged display stand
- 7. Horizontal adjustment bracket

HP Dual Hinge Notebook Stand (AW661AA)

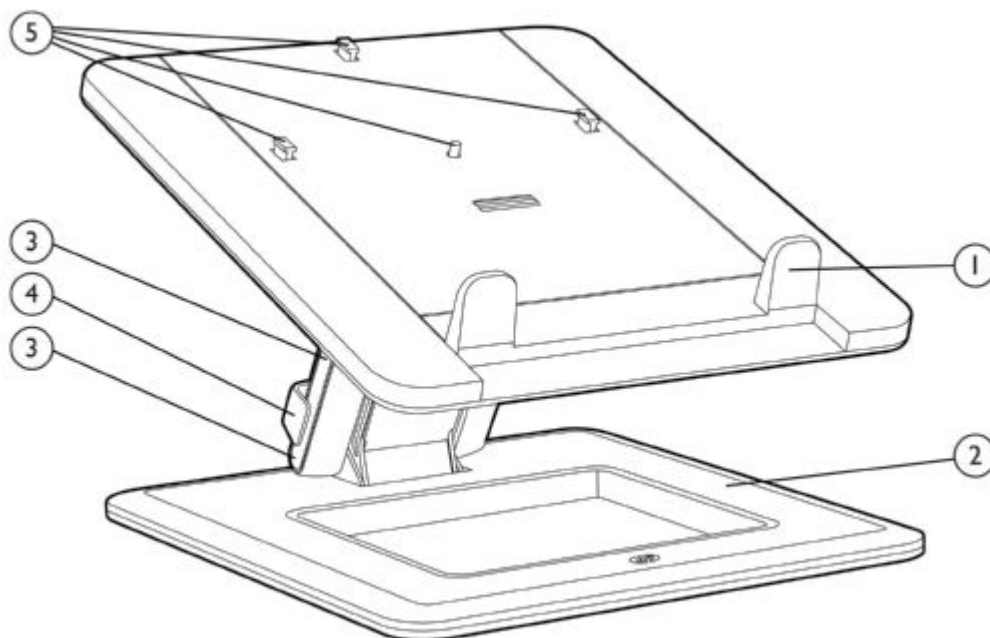

- 1. Adjustable shelf
- 2. Cable management channel
- 3. Adjustable shelf
- 4. Cable management channel
- 5. Cable management channel

Overview

- 2. Base
- 3. Dual-hinged display stand
- 5. Docking posts

HP Adjustable Display Stand (AW663AA)

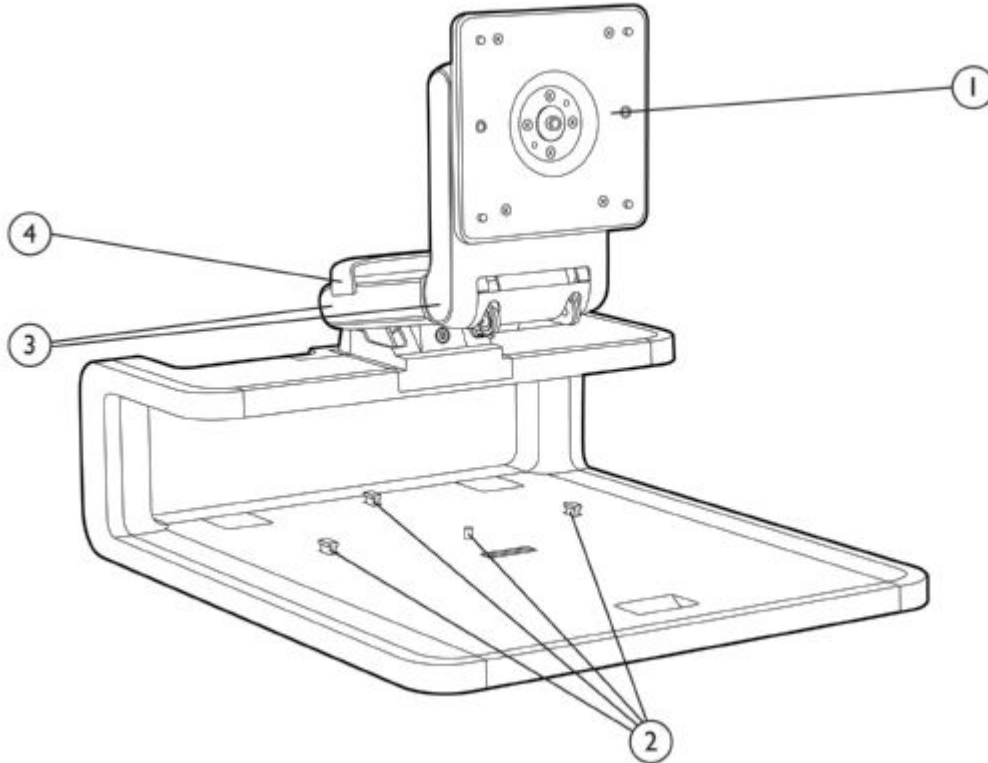

- 1. VESA display mount
- 2. Docking posts
- 3. Dual-hinged display stand
- 4. Cable management channel

HP LCD Monitor Stand (QM196AA)

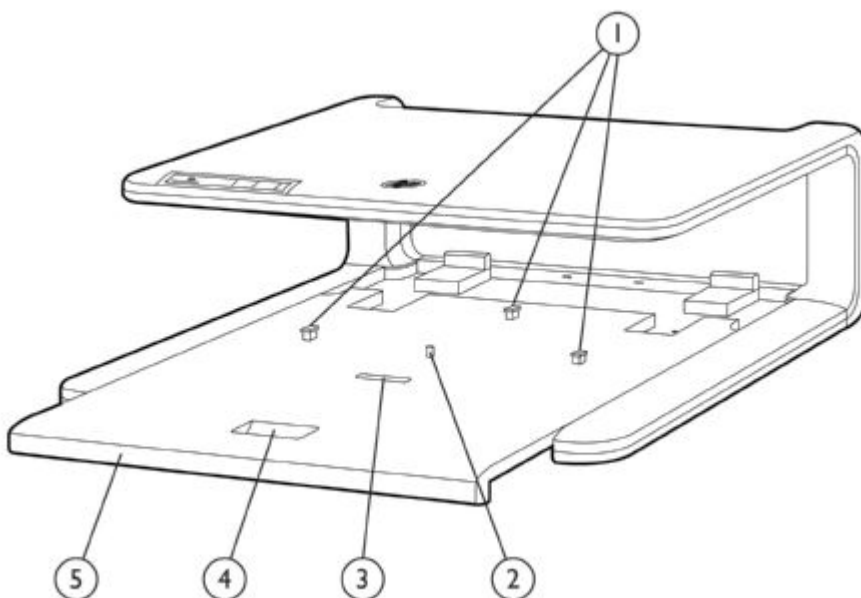

- 1. Docking posts
- 2. Docking release post
- 4. Sliding tray button
- 5. Sliding tray

Overview

3. Eject button
-

Technical Specifications

HP Adjustable Dual Display Stand (AW664AA)

Dimensions (H x W x D)	15.7 x 19.7 x 14.0 in (40.0 x 50.0 x 35.5 cm)
Weight	12.3 lb (5.6 kg)
Option Kit contents	HP Adjustable Dual Display Stand, documentation
VESA display mounts	Each display mount supports up to 15.4-lb (7.0-kg) VESA mounting interface displays and accessories.
Dual-hinged display stand	The dual-hinged, smooth-motion display stand allows for greater distance, height, and tilt adjustment for maximum comfort.
Adjustable shelf	Adjusts for different-sized notebook PCs.
Docking posts	Aligns and secures the docking station to the stand and helps secure a connected dock station.
Cable management channels	Organizes and hides accessory cables in a central location to help reduce clutter when connecting multiple devices.
Service and support	One-year limited warranty. Additional support is available 24 hours a day, seven days a week by phone as well as online support forums. NOTE: Certain restrictions and exclusions apply. Consult the HP Customer Support Center for details.
Weight Capacity	Each display mount supports up to 15.4-lb (7.0-kg) VESA mounting interface displays and accessories.
Compatibility	The HP Adjustable Dual Display Stand is compatible with all HP Notebook PCs and LCD displays up to 24 diagonal inches with a 100-mm VESA mounting pattern.

HP Display and Notebook Stand (AW662AA)

Dimensions (H x W x D)	19.0 x 27.2 x 18.5 in (48.0 x 69.0 x 47.0 cm)
Weight	14.6 lb (6.6 kg)
Option Kit contents	HP Display and Notebook Stand, monitor stand spacer, documentation
VESA display mounts	Supports up to 15.4-lb (7.0-kg) VESA mounting interface displays and accessories.
Dual-hinged display stand	The dual-hinged, smooth-motion display stand allows for greater distance, height, and tilt adjustment for maximum comfort.
Horizontal adjustment bracket	Adjusts the horizontal position of your display.
Adjustable shelf	Adjusts for different-sized notebook PCs.
Docking posts	Aligns and secures the docking station to the stand.
Cable management channels	Organizes and hides accessory cables in a central location to help reduce clutter when connecting multiple devices.
Service and support	One-year limited warranty. Additional support is available 24 hours a day, seven days a week by phone as well as online support forums. NOTE: Certain restrictions and exclusions apply. Consult the HP Customer Support Center for details.
Weight Capacity	Up to 15.4-lb (7.0-kg) VESA mounting interface displays and accessories.
Compatibility	The HP Display and Notebook Stand is compatible with all HP Notebook PCs and LCD displays up to 24 diagonal inches with a 100-mm VESA mounting pattern.

Technical Specifications

HP Dual Hinge Notebook Stand (AW661AA)

Dimensions (H x W x D)	8.7 x 11.8 x 14.2 in (22.0 x 30.0 x 36.0 cm)
Weight	7.5 lb (3.4 kg)
Option Kit contents	HP Dual Hinge Notebook Stand, monitor stand spacer, documentation
Dual-hinged display stand	The dual-hinged, smooth-motion display stand allows for greater distance, height, and tilt adjustment for maximum comfort.
Docking posts	Aligns and secures the docking station to the stand and helps secure a connected dockir station.
Adjustable shelf	Adjusts for different-sized notebook PCs.
Cable management channels	Organizes and hides accessory cables in a central location to help reduce clutter when connecting multiple devices.
Service and support	One-year limited warranty. Additional support is available 24 hours a day, seven days a week by phone as well as online support forums. NOTE: Certain restrictions and exclusions apply. Consult the HP Customer Support Center for details.
Weight Capacity	Supports 3.7 - 13.7- lbs (1.7-6.2 -kg) notebook or notebook and docking station
Compatibility	The HP Dual Hinge Notebook Stand is compatible with all HP Notebook PCs and LCD displays up to 24 diagonal inches with a 100-mm VESA mounting pattern.

HP Adjustable Display Stand (AW663AA)

Dimensions (H x W x D)	16.9 x 13.8 x 15.7 in (43.0 x 35.0 x 40.0 cm)
Weight	8.4 lb (3.8 kg)
Option Kit contents	HP Adjustable Display Stand, monitor stand spacer, documentation
VESA display mounts	Supports up to 15.4-lb (7.0-kg) VESA mounting interface displays and accessories.
Dual-hinged display stand	The dual-hinged, smooth-motion display stand allows for greater distance, height, and tilt adjustment for maximum comfort.
Docking posts	Aligns and secures the docking station to the stand and helps secure a connected dockir station.
Cable management channels	Organizes and hides accessory cables in a central location to help reduce clutter when connecting multiple devices.
Service and support	One-year limited warranty. Additional support is available 24 hours a day, seven days a week by phone as well as online support forums. NOTE: Certain restrictions and exclusions apply. Consult the HP Customer Support Center for details.
Weight Capacity	Supports up to 15.4-lb (7.0-kg) VESA mounting interface displays and accessories.
Compatibility	The HP Adjustable Display Stand is compatible with all HP Notebook PCs and LCD displays up to 24 diagonal inches with a 100-mm VESA mounting pattern. Note that this product is not compatible with the HP 2560p Docking Station (LE877AA).

Technical Specifications

HP LCD Monitor Stand (QM196AA)

Notebook bay dimensions (H x W x D)	5 x 13.8 x 16 in (12.7 x 35.1 x 40.7cm)
Upper platform dimensions (W x D)	13.8 x 10.8 in (35 x 27.5 cm)
Weight	8.6 lb (3.05 kg)
Option Kit contents	HP LCD Monitor Stand, monitor stand spacer, documentation
Power button	Turns on power to the system. The light is turned on when the docked computer is turned on.
AC power light	Lights up when the docking station is connected to the AC power.
Dock light	Lights up when the computer is successfully docked to the docking station.
MultiBay II activity light	Indicates MultiBay II drive activity (on Advanced Docking Station only).
Docking posts	Aligns and secures the docking station to the stand.
Docking release post	Secures a connected docking station.
Release button	Releases the docking station from the stand.
Tray slide button	Adjusts the position of the docking station and notebook PC.
Docking station cable	Connects the docking station so you can use the monitor stand power button and activity light.
Service and support	One-year limited warranty. Additional support is available 24 hours a day, seven days a week by phone as well as online support forums. NOTE: Certain restrictions and exclusions apply. Consult the HP Customer Support Center for details.
Compatibility	The HP LCD Monitor Stand is compatible with HP notebooks up to 17.3 diagonal inches, HP Basic and Advanced Docking Stations, and LCD displays up to 25 pounds with a base not exceeding the upper platform dimensions noted above. Note that this product is not compatible with the HP 2560p Docking Station (LE877AA).

HP Single Monitor Arm (BT861AA)

Dimensions (H x W x D)	N/A
Weight	7.91 lb (3.59 kg)
Option Kit contents	
Vertical height adjustment knob	
Cable management channels	
Service and support	
Compatibility	Supports displays weighing 7-20 lbs (3.1-9.1 kg)

© Copyright 2013 Hewlett-Packard Development Company, L.P. The information contained herein is subject to change without notice. The only warranties for HP products and services are set forth in the express warranty statements accompanying such products and services. Nothing herein should be construed as constituting an additional warranty. HP shall not be liable for technical or editorial errors or omissions contained herein.
March 2013