

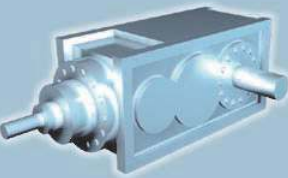

SEW
EURODRIVE

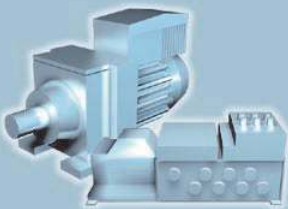
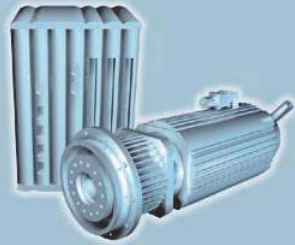

MOVIDRIVE[®] compact

DA410000

Edition 11/2006

11493011 / EN

Catalog

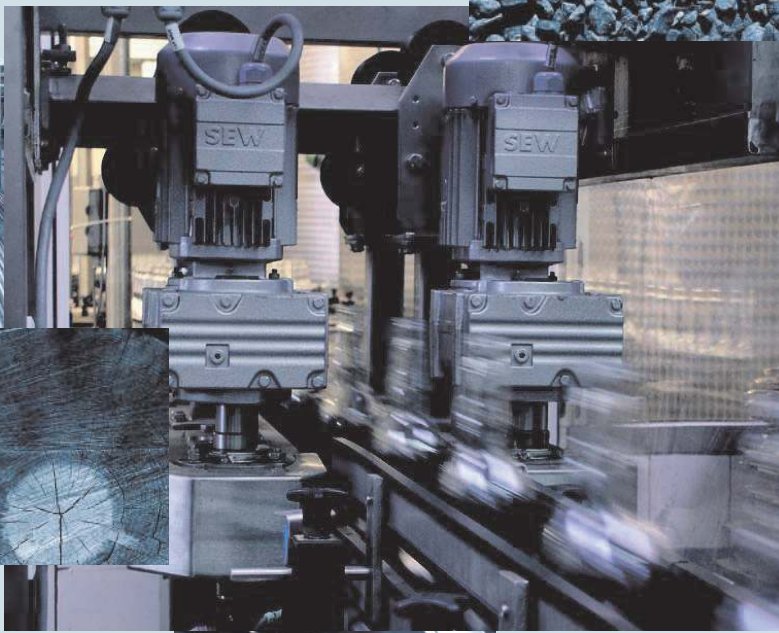
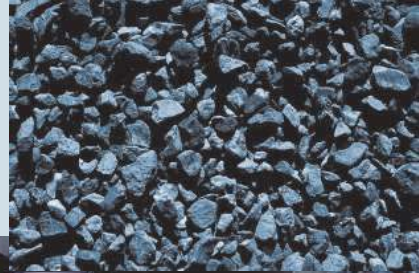



1 System Description	4
1.1 System overview	4
1.2 Functions / properties	10
1.3 Additional functions of the application version	12
1.4 Application modules for MOVIDRIVE® <i>compact</i>	16
1.5 MOVITOOLS® operating software	24
2 Technical Data and Dimension Drawings	25
2.1 CE marking, UL approval and unit designation.....	25
2.2 General technical data	27
2.3 MOVIDRIVE® <i>compact</i> MC_4_A...-5_3 (AC 400/500 V units).....	28
2.4 MOVIDRIVE® <i>compact</i> MC_4_A...-2_3 (AC 230 V units).....	38
2.5 MOVIDRIVE® <i>compact</i> MCF/MCV/MCS electronics data	46
2.6 MOVIDRIVE® <i>compact</i> MCH electronics data.....	50
2.7 MOVIDRIVE® <i>compact</i> dimension drawings	53
2.8 MOVIDRIVE® MDR60A regenerative power supply unit	58
2.9 IPOS ^{plus} ®	63
2.10 Optional DBG11B keypad.....	64
2.11 Serial interface option type USS21A (RS232 and RS485)	65
2.12 Interface adapter type USB11A / option DKG11A	66
2.13 DC 5 V encoder supply type DWI11A.....	67
2.14 Braking resistors type BW... / BW...-T / BW...-P	68
2.15 Line choke type ND.....	76
2.16 Line filter NF...-...	78
2.17 Output choke HD...	80
2.18 Output filter HF.....	81
2.19 Prefabricated cables	85
3 Motor Selection	98
3.1 Motor selection for asynchronous AC motors (VFC).....	98
3.2 Motor selection for asynchronous servomotors (CFC).....	106
3.3 Motor Selection for Synchronous Servomotors (SERVO).....	123
4 Index of Changes	129
4.1 Changes compared to the previous version.....	129
5 Index	130



1 System Description

1.1 System overview

Power components

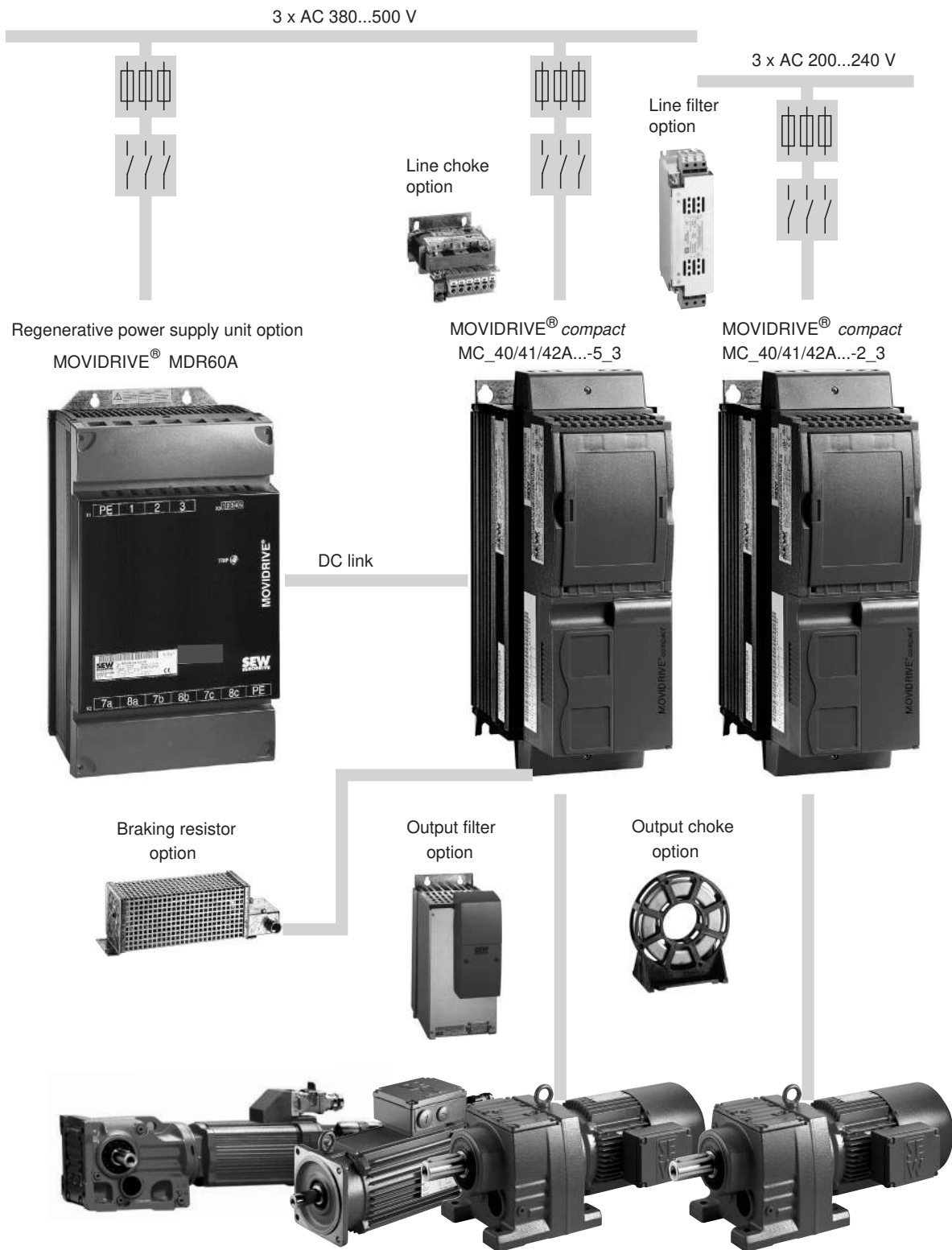

Figure 1: System overview of the power components for MOVIDRIVE® compact MC_4_A

59831AEN



Communication components

MOVIDRIVE® compact standard version IPOS plus® as standard



Interface adapter option

Keypad option



USS21A

USB11A

DBG11B

MOVIDRIVE® compact application version for using "Electronic cam", "Internal synchronous operation" or the application modules.

MOVITOOLS® operating software

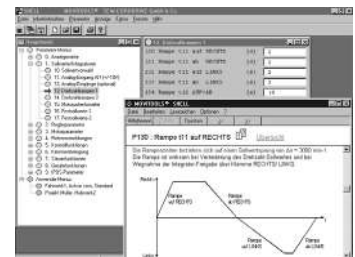
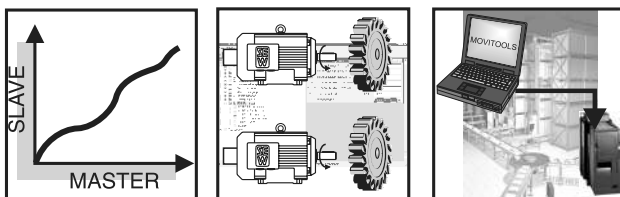

59832AEN

Figure 2: System overview of the communication components for MOVIDRIVE® compact MC_4_A



General description

MOVIDRIVE[®] compact is the term used to describe compact and powerful drive inverters from SEW-EURODRIVE. Perfectly matched to your requirements, you can use **MOVIDRIVE[®] compact** to realize AC drives in the power range from 1.5 to 90 kW. Thanks to tried and tested inverter technology and SEW control modes, you can meet the highest demands in terms of both dynamics and control quality.

Unit series

The **MOVIDRIVE[®] compact** range includes four series:

- **MOVIDRIVE[®] compact MCF:** Drive inverter for asynchronous AC motors without encoder feedback, VFC control mode.
- **MOVIDRIVE[®] compact MCV:** Drive inverter for asynchronous AC motors with encoder feedback, either VFC or CFC control mode.
- **MOVIDRIVE[®] compact MCS:** Drive inverter for synchronous servomotors with encoder (resolver), SERVO control mode.
- **MOVIDRIVE[®] compact MCH:** Drive inverter for either asynchronous AC motors, asynchronous servomotors or synchronous servomotors. Encoder feedback with either a Hiperface encoder, sin/cos encoder or TTL sensor.

Unit variants

The MCF, MCV and MCS series are available in 2 variants:

- **MCF/MCV/MCS40A:** Control via binary inputs and setpoint selection via analog setpoint input.
- **MCF/MCV/MCS41A:** Control via either PROFIBUS-DP interface or binary inputs. Setpoint selection via PROFIBUS-DP interface.

The MCH series is available in 3 variants:

- **MCH40A:** Control via binary inputs and setpoint selection via analog setpoint input.
- **MCH41A:** Control via either PROFIBUS-DP interface, binary inputs or analog outputs. Setpoint selection via PROFIBUS-DP interface.
- **MCH42A:** Control via either INTERBUS-LWL (FO) interface or binary inputs. Setpoint selection via INTERBUS-LWL (FO) interface.

Unit versions

MOVIDRIVE[®] compact drive inverters are each available in two versions, namely the standard version and the application version.

Standard version

Units are equipped with the integrated IPOS^{plus}[®] positioning and sequence control system as standard and can be extended with the available options.

The standard version is indicated by the characters "00" at the end of the unit designation.

Application version

In addition to the features of the standard version, these units include the technology functions "electronic cam" and "internal synchronous operation." You can also use all the application modules available in the MOVITOOLS[®] software package with the application versions.

The application version is indicated by the characters "0T" at the end of the unit designation.



Overview of series and variants

The following table gives an overview of the series and variants:

	Without encoder input	With encoder input for sin/cos and incremental encoders	With resolver input	With encoder input for Hiperface, sin/cos and incremental encoders
Without fieldbus	MCF40A	MCV40A	MCS40A	MCH40A
With PROFIBUS-DP	MCF41A	MCV41A	MCS41A	MCH41A
With INTERBUS-LWL	-	-	-	MCH42A

Control modes

The VFC (Voltage Mode Flux Control) and CFC (Current Mode Flux Control) control modes are features of MOVIDRIVE® compact drive inverters. The continuous calculation of the complete motor model forms the basis for both control modes.

VFC (Voltage Mode Flux Control) control mode	CFC (Current Mode Flux Control)/SERVO control mode
Voltage-controlled control mode for AC asynchronous motors with and without encoder feedback. <ul style="list-style-type: none"> • With encoder feedback <ul style="list-style-type: none"> – at least 150 % torque, even with motor at standstill – characteristics similar to servo operation • Without encoder feedback <ul style="list-style-type: none"> – at least 150 % torque up to 0.5 Hz 	Current-controlled control mode for AC asynchronous motors and permanent-field AC servomotors. Encoder feedback is always required. <ul style="list-style-type: none"> • at least 160 % torque, even with motor at standstill • maximum precision and concentric running characteristics right down to standstill • servo characteristics and torque control even for asynchronous AC motors • reacts to load changes within a few milliseconds

System bus (SBus)

The system bus (SBus), which is available as standard, allows several MOVIDRIVE® drive inverters to be networked together. This system bus enables fast data exchange between the units. The SEW standard unit profile MOVILINK® is used for communication via SBus.

MOVILINK®

The same message format is always used with MOVILINK® independent of the selected interface (SBus, RS232, RS485, fieldbus interfaces). As a result, the control software is independent of the selected interface.

IPOS^{plus}®

A key feature of MOVIDRIVE® drive inverters is that the IPOS^{plus}® positioning and sequence control system is integrated as standard. IPOS^{plus}® enables you to control sequences of motion directly in the inverter close to the machine. This way, load is taken off the higher-level controller and modular concepts can be implemented more easily.



An overview of the units

MOVIDRIVE[®] compact for 3 × AC 380 ... 500 V supply voltage (AC 400/500 V units):

Recommended motor power (VFC) (at $V_{\text{mains}} = 3 \times \text{AC } 400 \text{ V}$)		Continuous output current (CFC)	MOVIDRIVE [®] compact type				Size (technical data)
			MCF4_A asynchronous without encoder	MCV4_A asynchronous with encoder	MCS4_A synchronous with resolver	MCH42A asynchronous/ synchronous with encoder	
1.5 kW	2.2 kW	AC 4.0 A	0015-5A3-4..	0015-5A3-4..	0015-5A3-4..	0015-5A3-4..	1 (→ page 28)
2.2 kW	3.0 kW	AC 5.5 A	0022-5A3-4..	0022-5A3-4..	0022-5A3-4..	0022-5A3-4..	
3.0 kW	4.0 kW	AC 7.0 A	0030-5A3-4..	0030-5A3-4..	0030-5A3-4..	0030-5A3-4..	
4.0 kW	5.5 kW	AC 9.5 A	0040-5A3-4..	0040-5A3-4..	0040-5A3-4..	0040-5A3-4..	
5.5 kW	7.5 kW	AC 12.5 A	0055-5A3-4..	0055-5A3-4..	0055-5A3-4..	0055-5A3-4..	2 (→ page 30)
7.5 kW	11 kW	AC 16 A	0075-5A3-4..	0075-5A3-4..	0075-5A3-4..	0075-5A3-4..	
11 kW	15 kW	AC 24 A	0110-5A3-4..	0110-5A3-4..	0110-5A3-4..	0110-5A3-4..	3 (→ page 32)
15 kW	22 kW	AC 32 A	0150-503-4..	0150-503-4..	0150-503-4..	0150-503-4..	
22 kW	30 kW	AC 46 A	0220-503-4..	0220-503-4..	0220-503-4..	0220-503-4..	
30 kW	37 kW	AC 60 A	0300-503-4..	0300-503-4..	0300-503-4..	0300-503-4..	4 (→ page 34)
37 kW	45 kW	AC 73 A	0370-503-4..	0370-503-4..	0370-503-4..	0370-503-4..	
45 kW	55 kW	AC 89 A	0450-503-4..	0450-503-4..	0450-503-4..	0450-503-4..	5 (→ page 36)
55 kW	75 kW	AC 105 A	0550-503-4..	0550-503-4..	0550-503-4..	0550-503-4..	
75 kW	90 kW	AC 130 A	0750-503-4..	0750-503-4..	0750-503-4..	0750-503-4..	

MOVIDRIVE[®] compact for 3 × AC 200 ... 240 V supply voltage (AC 230 V units):

Recommended motor power (VFC) (at $V_{\text{mains}} = 3 \times \text{AC } 230 \text{ V}$)		Continuous output current (CFC)	MOVIDRIVE [®] compact type				Size (technical data)
			MCF4_A asynchronous without encoder	MCV4_A asynchronous with encoder	MCS4_A synchronous with resolver	MCH42A asynchronous/ synchronous with encoder	
1.5 kW	2.2 kW	AC 7.3 A	0015-2A3-4..	0015-2A3-4..	0015-2A3-4..	0015-2A3-4..	1 (→ page 38)
2.2 kW	3.7 kW	AC 8.6 A	0022-2A3-4..	0022-2A3-4..	0022-2A3-4..	0022-2A3-4..	
3.7 kW	5.0 kW	AC 14.5 A	0037-2A3-4..	0037-2A3-4..	0037-2A3-4..	0037-2A3-4..	
5.5 kW	7.5 kW	AC 22 A	0055-2A3-4..	0055-2A3-4..	0055-2A3-4..	0055-2A3-4..	2 (→ page 40)
7.5 kW	11 kW	AC 29 A	0075-2A3-4..	0075-2A3-4..	0075-2A3-4..	0075-2A3-4..	
11 kW	15 kW	AC 42 A	0110-203-4..	0110-203-4..	0110-203-4..	0110-203-4..	3 (→ page 42)
15 kW	22 kW	AC 54 A	0150-203-4..	0150-203-4..	0150-203-4..	0150-203-4..	
22 kW	30 kW	AC 80 A	0220-203-4..	0220-203-4..	0220-203-4..	0220-203-4..	4 (→ page 44)
30 kW	37 kW	AC 95 A	0300-203-4..	0300-203-4..	0300-203-4..	0300-203-4..	

MOVIDRIVE[®] MDR60A regenerative power supply units for AC 400/500 V units:

MOVIDRIVE [®] MDR60A regenerative power supply units		Size	MOVIDRIVE [®] compact
0370-503-00	$I_{\text{mains}} = \text{AC } 66 \text{ A}, I_{\text{DC link}} = \text{DC } 70 \text{ A}$	3	1.5 ... 37 kW
0750-503-00	$I_{\text{mains}} = \text{AC } 117 \text{ A}, I_{\text{DC link}} = \text{DC } 141 \text{ A}$	4	1.5 ... 75 kW
1320-503-00	$I_{\text{mains}} = \text{AC } 260 \text{ A}, I_{\text{DC link}} = \text{DC } 340 \text{ A}$	6	



Block circuit diagram

The following block circuit diagram shows the basic structure and theory of operation of MOVIDRIVE[®] compact drive inverters using the example of MOVIDRIVE[®] compact MCV41A.

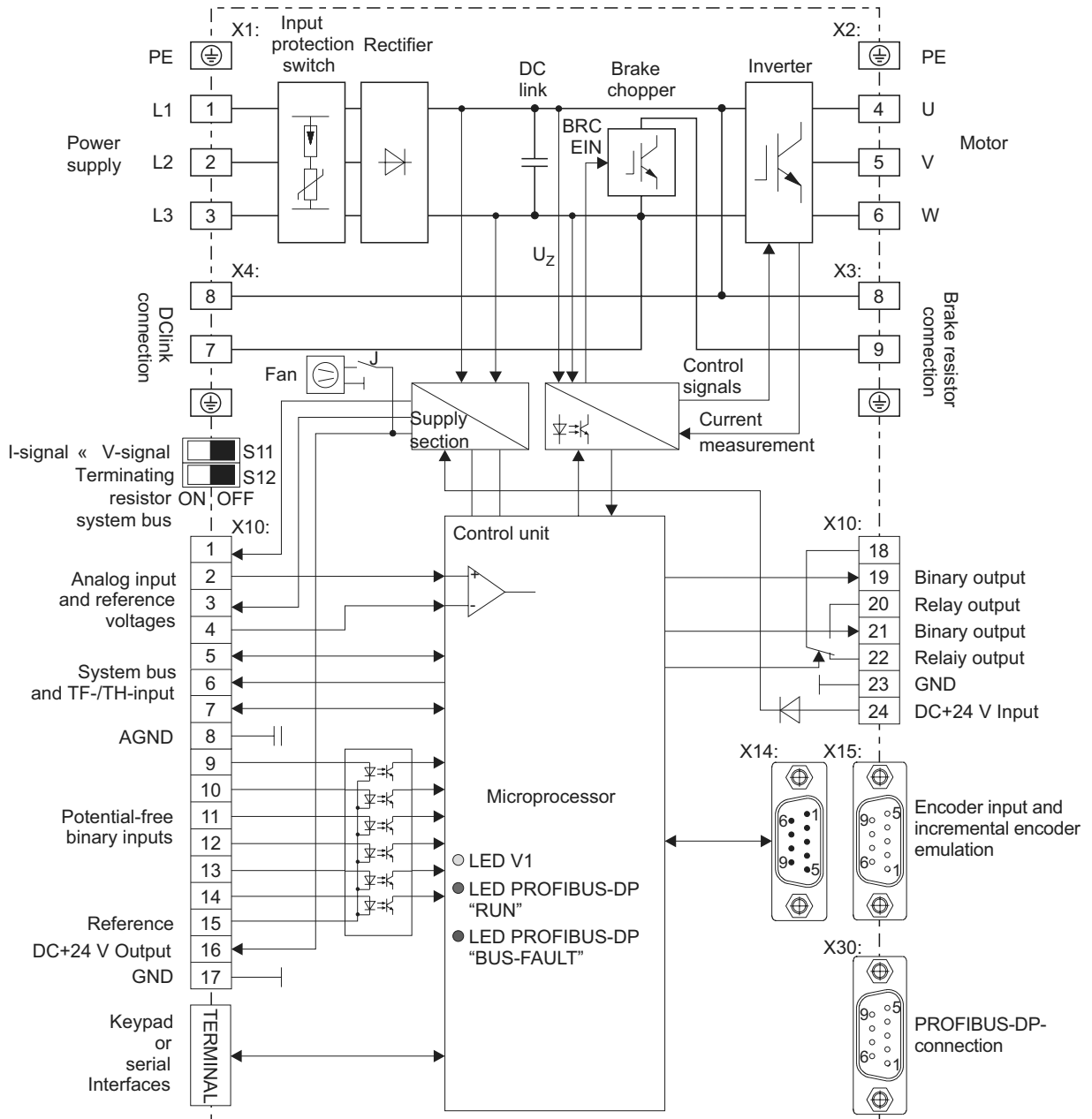

59823AEN

Figure 3: Block circuit diagram for MOVIDRIVE[®] compact MCV41A



1.2 Functions / properties

Unit properties

- Wide voltage range
 - AC 400/500 V units for the voltage range $3 \times AC 380 \dots 500 V$
 - AC 230 V units for the voltage range $3 \times AC 200 \dots 240 V$
- High overload capacity
 - 150 % I_N , short-term
 - 125 % I_N , sustained operation without overload (pumps, fans)
- With 4 kHz switching frequency, I_N is permitted for an ambient temperature $\vartheta = 50 \text{ }^\circ\text{C}$
- 4Q capability due to integrated brake chopper installed as standard
- Compact unit design for minimum control cabinet space requirement and optimum utilization of control cabinet volume
- Integrated line filter fitted as standard in sizes 1 and 2, complies with class A limit on the input side without any additional measures
- 6 isolated binary inputs and 3 binary outputs, one of which is a relay output, programmable inputs/outputs
- 1 TF/TH input for motor protection via PTC thermistor or thermocontact
- 3-color LED for displaying operating and error states
- Separate DC 24 V voltage input for powering the inverter electronics (parameter setting, diagnostics and data backup even when the supply system is switched off)
- Removable connection unit and, with MOVIDRIVE[®] compact MCH4_A, separable electronics terminals
- Separable power terminals for size 1 units

Control functionality

- VFC or CFC control modes for field-oriented operation (asynchronous servo)
- With MCH4_A: Either asynchronous or synchronous AC motors can be operated
- IPOS^{plus}[®] positioning and sequence control system integrated as standard
- 2 complete parameter sets
- Automatic motor calibration
- Automatic brake control by the inverter
- DC braking to decelerate the motor even in 1Q mode
- Slip compensation for high static speed accuracy even without encoder feedback
- Flying restart circuit for synchronizing the inverter to an already rotating motor
- Hoist capability with all motor systems that can be connected
- Motor pull-out protection through sliding current limitation in the field weakening range
- Function to hide speed window to avoid mechanical resonances
- Heating current to avoid condensation build-up in the motor
- Factory settings can be restored
- Parameter lock for protection against changes to parameters
- Speed controller and encoder input for types MCV (either sin/cos, TTL or HTL encoder), MCS (resolver) and MCH (either Hiperface, sin/cos or TTL encoder). Intuitive controller setting tool in the user interface



- Protective functions for complete protection of the inverter and motor (short-circuit, overload, overvoltage/undervoltage, low-impedance ground fault, overtemperature in the inverter, motor stall prevention, overtemperature in the motor)
- Speed monitoring and monitoring of the motor and regenerative limit power
- Programmable signal range monitoring (speed, current, maximum current)
- Memory for displaying x/t diagrams using SCOPE process data visualization (4 channels, real-time capability)
- Fault memory (5 memory locations) with relevant operating data at the time the fault occurs
- Elapsed-time counter for hours of operation (unit connected to supply system or DC 24 V) and enable hours (output stage energized)
- Uniform operation, identical parameter setting and the same unit connection technology for the entire MOVIDRIVE® unit series

Setpoint technology

- Ramp switchover (total of 4 ramps)
- Motor potentiometer, can be combined with analog setpoint and internal fixed setpoints
- External setpoint selections: DC 0 ... +10 V, ±10 V, 0 ... 20 mA, 4 ... 20 mA (except with MOVIDRIVE® compact MCF41A) or fieldbus (only with MC_41A/42A)
- S pattern for jerk-free speed changes
- Programmable input characteristic curve for flexible setpoint processing
- Six bipolar fixed setpoints that can be combined with external setpoints and motor potentiometer function

Communication / operation

- System bus for networking max. 64 MOVIDRIVE® units
- PROFIBUS-DP interface (max. 12 MBaud) with MC_41A and INTERBUS-LWL interface with MCH42A
- Simple startup and parameter setting using keypad or PC

System expansion

- Extensive expansion options, for example:
 - Removable plain text keypad with parameter memory
 - USB11A interface adapter
 - RS232 and RS485 serial interfaces
 - Braking resistors, line filters, line chokes, output chokes, output filters
- MOVITOOLS® operating software with SCOPE process data visualization
- Application version with access to technology functions and application modules to solve drive tasks quickly and easily
- MOVIDRIVE® MDR60A regenerative power supply unit
 - Regenerative energy is fed back into the supply system
 - Reduces the thermal load in the control cabinet and helps cut costs

Standards / certificates

- UL, cUL and C-Tick approval
- Safe disconnection of power and electronic connections according to EN 61800-5-1
- Complies with all the requirements for CE certification of machines and plants equipped with MOVIDRIVE® units on the basis of the EC Low Voltage Directive 73/23/EEC and the EMC Directive 89/336/EEC. Complies with the EMC product standard EN 61800-3.



1.3 Additional functions of the application version

SEW-EURODRIVE offers additional functions for special applications. You can use these additional functions with MOVIDRIVE® units in the application version (...-0T).

The following additional functions are available:

- Electronic cam
- Internal synchronous operation

Refer to the "Electronic Cam" and "Internal Synchronous Operation" manuals for detailed information on the additional functions.

Electronic cam



You can use the MOVIDRIVE® range of units with "electronic cam" whenever you need to harmonize complex sequences of motion in cyclical machines. This solution gives you much greater flexibility compared to the mechanical cam. As a result, it meets the needs of modern production and processing lines.

A user-friendly cam editor assists you during startup. You also have the option of importing existing cam data. You can also set application-specific parameters for the engagement and disengagement phases using the cam editor.

Note the following points:

- The "electronic cam" can only be implemented with MOVIDRIVE® units in application version (...-0T).
- Encoder feedback is mandatory. "Electronic cam" can be implemented using the following operating modes:
 - MOVIDRIVE® *compact* MCV in CFC operating modes
 - MOVIDRIVE® *compact* MCS in SERVO operating modes
 - MOVIDRIVE® *compact* MCH in CFC or SERVO operating modes
- "Electronic cam" **cannot** be implemented with:
 - MOVIDRIVE® *compact* MCV/MCH in VFC and VFC-n CTRL modes
 - MOVIDRIVE® *compact* MCF
- "Electronic cam" is only available in parameter set 1.

Motors and encoders

Use the following motor types:

- For operation with MOVIDRIVE® *compact* MCV4_A...-5_3-4-0T:
 - CT/CV asynchronous servomotors with high-resolution sin/cos encoder
 - DT/DV AC motor with incremental encoder, preferably with a high-resolution sin/cos encoder
- For operation with MOVIDRIVE® *compact* MCS4_A...-5_3-4-0T:
 - DS/CM synchronous servomotor with resolver



- For operation with MOVIDRIVE® compact MCH4_A...-5_3-4-0T:
 - CT/CV asynchronous servomotors with sin/cos encoder or AV1H (HIPERFACE® encoder)
 - DT/DV AC motors with sin/cos encoder, AV1H (HIPERFACE® encoder) or RS422 encoder
 - CM synchronous servomotors with AS1H/ES1H (HIPERFACE® encoder)

High-resolution speed measurement is required for optimum operation of the electronic cam. The encoders installed as standard in CT/CV and DS/CM motors fulfill these requirements. SEW-EURODRIVE recommends using high-resolution sin/cos encoders as incremental encoders if DT/DV motors are used.

Example

The figure below shows a typical application for the "electronic cam." Filled yoghurt pots are being transported for further processing. The "electronic cam" allows for smooth movement, which is an important requirement for this application.

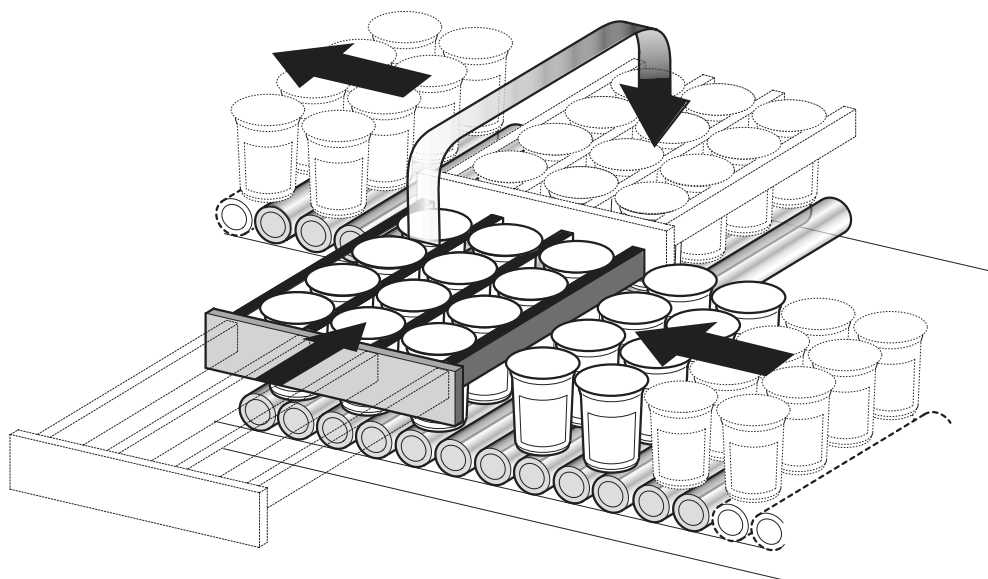

Figure 4: Typical application for the "electronic cam"

03672AXX



System Description

Additional functions of the application version

Internal synchronous operation

You can always use the MOVIDRIVE® range of units with "internal synchronous operation" whenever a group of motors has to be operated at a synchronous angle in relation to one another or with an adjustable proportional ratio (electronic gear). A user-friendly editor guides you through the startup procedure.

Note the following points:

- "Internal synchronous operation" can only be implemented with MOVIDRIVE® units in application version (...-0T).
- Encoder feedback is mandatory. "Internal synchronous operation" can be implemented using the following operating modes:
 - MOVIDRIVE® *compact* MCV in CFC operating modes
 - MOVIDRIVE® *compact* MCS in SERVO operating modes
 - MOVIDRIVE® *compact* MCH in CFC or SERVO operating modes
- "Internal synchronous operation" **cannot** be implemented with:
 - MOVIDRIVE® *compact* MCV/MCH in VFC and VFC-n-CRTL operating modes
 - MOVIDRIVE® *compact* MCF
- "Internal synchronous operation" is only available in parameter set 1.

Motors and encoders

Use the following motor types:

- For operation with MOVIDRIVE® *compact* MCV4_A...-5_3-4-0T:
 - CT/CV asynchronous servomotors with high-resolution sin/cos encoder
 - DT/DV AC motor with incremental encoder, preferably with a high-resolution sin/cos encoder
- For operation with MOVIDRIVE® *compact* MCS4_A...-5_3-4-0T:
 - DS/CM synchronous servomotor with resolver
- For operation with MOVIDRIVE® *compact* MCH4_A...-5_3-4-0T:
 - CT/CV asynchronous servomotors with sin/cos encoder or AV1H (HIPERFACE® encoder)
 - DT/DV AC motors with sin/cos encoder, AV1H (HIPERFACE® encoder) or RS422 encoder
 - CM synchronous servomotors with AS1H/ES1H (HIPERFACE® encoder)

High-resolution speed measurement is required for optimum operation of the "internal synchronous operation." The encoders installed as standard in CT/CV and DS/CM motors fulfill these requirements. SEW-EURODRIVE recommends using high-resolution sin/cos encoders as incremental encoders if DT/DV motors are used.



Example

The figure below shows a typical application for "internal synchronous operation." Extruder material must be cut to length. The saw receives a start signal and synchronizes with the material. During the sawing process, the saw moves synchronously with the material. At the end of the sawing process the saw moves back to its starting position.

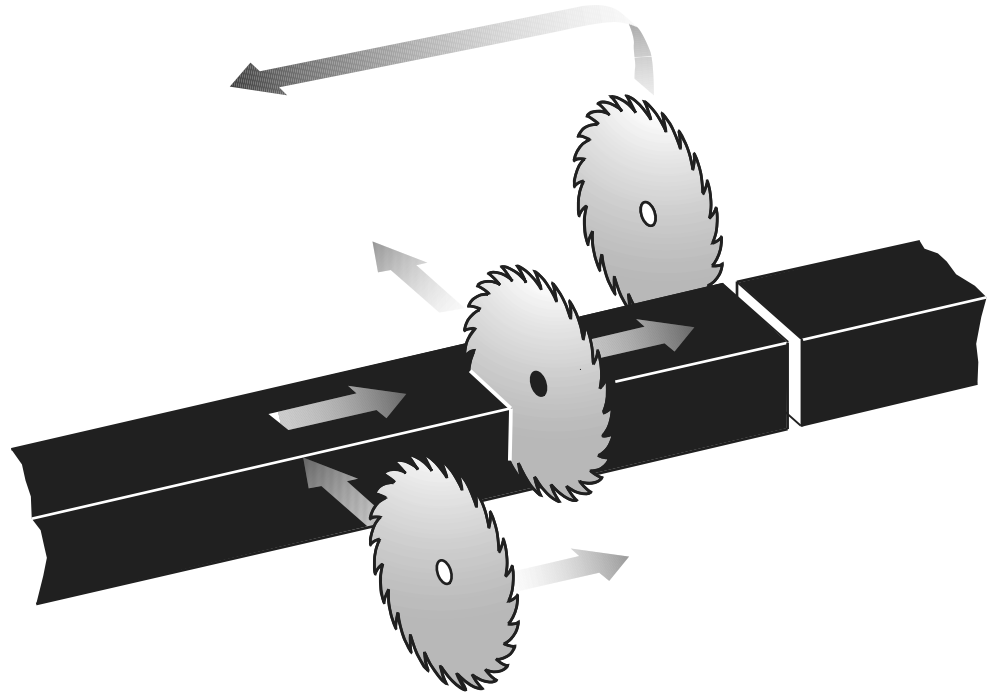

Figure 5: Typical application for the "internal synchronous operation" function

03866AXX



1.4 Application modules for MOVIDRIVE® compact

The drive application

The drive application often involves more than just adjusting the speed of a motor. The inverter often has to control motion sequences and take on typical PLC tasks. Increasingly complex drive applications have to be solved, without this resulting in lengthy project planning and startup processes.

The solution with MOVIDRIVE®

SEW-EURODRIVE offers various standardized control programs specifically for "positioning," "winding" and "controlling" applications. These programs are called application modules. The application modules are part of the MOVITOOLS® operating software and can be used with units in application version.

A user-friendly user interface guides you through the process of setting the parameters. All you have to do is enter the parameters you need for your application. The application module uses this information to create the control program and loads it into the inverter. MOVIDRIVE® takes over complete control of the motion processes, the load is taken off the machine control and decentralized concepts are easier to implement.

The advantages at a glance

- Wide range of functions
- User-friendly user interface
- You only have to enter the parameters needed for the application
- Guided parameter setting process instead of complicated programming
- No programming know-how required
- No lengthy training, therefore quick project planning and startup
- All movement functions are controlled directly in MOVIDRIVE®
- Decentralized concepts can be implemented more easily

Scope of delivery and documentation

The application modules are part of the MOVITOOLS® software and can be used with MOVIDRIVE® compact in application version (...-0T). The individual application manuals can also be downloaded as PDFs from the SEW homepage.

Available application modules

The application modules currently available are listed below. These application modules are explained in the following pages.

Positioning

Linear movement; the inverter manages the movement records:

- Table positioning via terminal or fieldbus

Linear movement; the PLC manages the movement records:

- Positioning via bus
- Extended positioning via bus
- Absolute positioning (rapid / creep speed positioning)

Rotary movement:

- Module positioning via terminals: The inverter manages the movement records
- Module positioning via fieldbus: The PLC manages the movement records

Winding

- Center winder

Controlling

- Flying saw
- DriveSync via fieldbus
- Sensor-based positioning



Use

The following illustration shows an example of how the various SEW application modules are used in a high-bay warehouse.

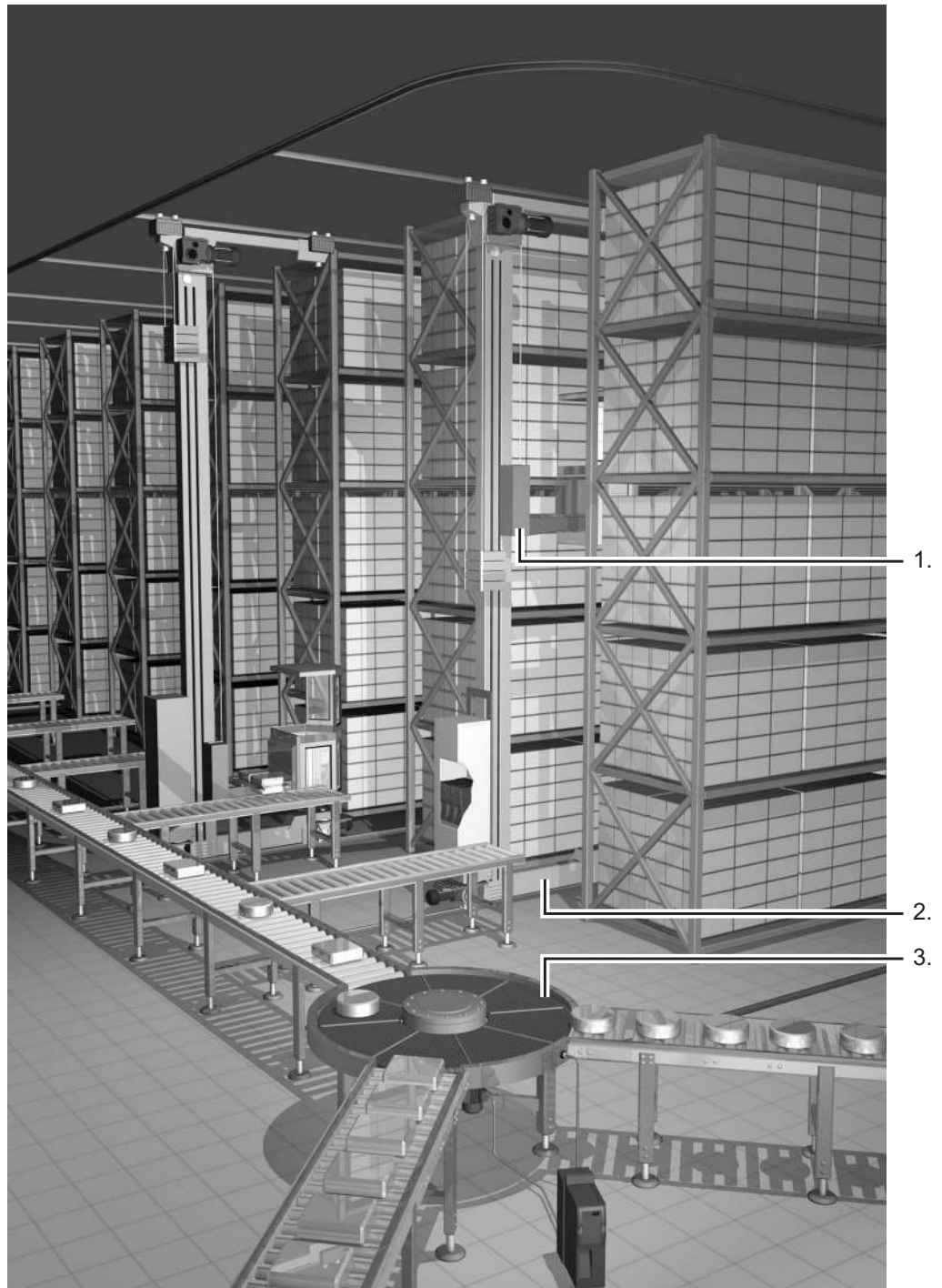

Figure 6: Application in a high-bay warehouse

04008AXX

1. Hoist: table positioning
2. Travel axis: absolute or bus positioning
3. Rotary distributor: Modulo positioning



System Description

Application modules for MOVIDRIVE® compact

Positioning

The application modules for the "Positioning" application are suited to all applications where target positions are specified and movement then takes place to those positions. Movement can either be linear or rotatory.

For example, trolleys, hoists, gantries, rotary tables, swiveling devices and storage and retrieval units.

Linear positioning

In the case of application modules for linear positioning, SEW-EURODRIVE distinguishes between whether the movement records are managed in the inverter or the higher-level PLC.

Movement records in the inverter

- **Table positioning via terminals**
- **Table positioning via fieldbus**

These application modules are suited to applications in which movement only has to take place to a limited number of target positions and in which the highest possible degree of independence from the machine control is required.

Up to 32 movement records can be managed in the inverter in these application modules. A movement record comprises target position, speed and ramp. The target position to which movement is to take place is selected using binary code, by means of the binary inputs of the inverter or via the virtual terminals (fieldbus, system bus). These application modules come with the following features:

- Up to 32 table positions can be defined and selected.
- The travel speed can be selected for each positioning movement.
- The ramp can be set separately for each positioning movement.
- Software limit switches can be defined and evaluated.
- Either incremental or absolute encoders can be evaluated.
- Guided startup and diagnosis.

Four operating modes are available for controlling the machine:

- Jog mode: The machine can be moved manually.
- Reference travel: The machine zero is determined automatically for incremental position measurement.
- Teach-In: The saved position can be corrected without a programming device.
- Automatic mode: Higher-level PLC controls the process automatically.

Movement records in the PLC

- **Positioning via bus**
- **Extended positioning via bus**

These application modules are suited to applications with a high number of different target positions.

The movement records are managed in the PLC for these application modules. The target position and travel speed are specified via the fieldbus or system bus. These application modules have the following features:

- Any number of target positions can be defined and selected via fieldbus / system bus.
- The travel speed can be selected as required via the fieldbus / system bus for each positioning movement.
- Software limit switches can be defined and evaluated.
- Either incremental or absolute encoders can be evaluated.
- Straightforward connection to the higher-level controller.



- Guided startup and diagnosis.

Three operating modes are available for controlling the machine:

- Jog mode: The machine can be moved manually.
- Reference travel: The machine zero is determined automatically for incremental position measurement.
- Automatic mode: The higher-level PLC controls the process automatically.

- **Absolute positioning (rapid / creep speed positioning)**

This application module is suitable for applications in which there is a high tendency to vibrate, for example storage and retrieval units for high-bay warehouses or heavy trolleys.

In this application module, the movement records are also managed in the PLC and specified via the fieldbus or system bus. No motor encoder is required. The absolute encoder mounted on the travel path is used for positioning. This application module has the following features:

- Any number of target positions can be defined and selected via fieldbus / system bus.
- Software limit switches can be defined and evaluated.
- Only absolute encoders are used for position measurement.
- No motor encoder is required.
- Straightforward connection to the higher-level controller.
- Guided startup and diagnosis.

The following operating modes are available for controlling the machine:

- Jog mode: The machine can be moved manually.
- Automatic mode: The higher-level PLC controls the process automatically.

**Rotational positioning****• Modulo positioning**

A large number of movements have to be controlled in automated conveyor and logistics applications to transport the material. Linear movements in the form of trolleys or hoists, and rotary movements via rotary tables play a key role in these applications.

Rotary movements are often synchronized (circular transfer tables); the material is fed at a specific degree. However, there are also many rotational applications in which the material should be moved to its destination by the shortest possible route (distance-optimized positioning) or in which it is only permitted to move to the target position in a defined direction of rotation (positioning with fixed direction of rotation).

The position axis is represented on a numbered circle from 0 ° to 360 ° to meet these requirements. The actual position is always in this range.

The "modulo positioning" application module accomplishes these tasks using various operating modes which are selected via binary inputs (16 table positions) or virtual terminals (control via fieldbus, variable positions).

The following operating modes are available for controlling the machine:

- Jog mode
- Teach mode (terminal control only)
- Referencing mode
- Automatic mode with position optimization
- Automatic mode with direction of rotation inhibit (clockwise - counterclockwise)
- Synchronous automatic mode

The "modulo positioning" module offers the following advantages:

- User-friendly user interface
- Only the parameters required for Modulo positioning (number of teeth in the gear unit, speed) have to be entered
- Guided parameter setting instead of complicated programming
- Monitor mode for optimum diagnosis
- Users do not need any programming experience
- Rapid familiarization with the system



Winding

- **Center winder**

The "center winder" application module is suitable for applications in which endless material, such as paper, plastic, fabrics, sheet metal or wire, must be wound, unwound or rewound continuously.

Control takes place either via the binary inputs of the inverter or via the virtual terminals (fieldbus, system bus).

The "center winder" application module has the following features:

- Constant tensile force or web speed independent of the diameter.
- Automatic calculation of the speed-dependent friction factors via a teach-in run.
- Winding characteristics to prevent the winding material from becoming loose.
- Binary selection of 4 different winding cores.
- Diameter can be determined using a diameter calculator (master encoder required) or an analog input (distance sensor required).
- Free-running function (jog).
- CW / CCW winding, winding / unwinding.
- Simple connection to the higher-level controller (PLC).
- Guided startup and diagnosis.

Four operating modes are available for controlling the machine:

- Jog mode: The machine can be moved to the right or the left manually.
- Teach-in run: The speed-dependent friction factors are determined automatically.
- Automatic mode with constant tension.
- Automatic mode with constant velocity.



System Description

Application modules for MOVIDRIVE® compact

Controlling

- **Flying saw**

The "flying saw" application module is suited to applications in which endless material has to be cut, sawn or pressed, for example in diagonal saws or flying punches.

This application module is used to control the sequence of motion according to specific values. This application module has the following features:

- Choice of fieldbus or terminal control.
- Cut edge protection or sorting using the "pulling a gap" function.
- Immediate cut function by manual interrupt.
- Counter for material length.
- Straightforward connection to the higher-level controller.
- Guided startup and diagnosis.

Four operating modes are available for controlling the machine:

- Jog mode: The machine can be moved manually.
- Reference travel: The system reference point is determined.
- Positioning mode
- Automatic operation

- **DriveSync via fieldbus**

The "DriveSync via fieldbus" application module makes it possible to implement conveyor systems and machinery with drives that have to move at a synchronous angle occasionally or permanently.

The program can be used for the master drive and the slave drive. The master works in the "jog" and "positioning" operating modes, while the slave drives are operated in "synchronous operation" mode.

If the "synchronous operation" mode is deselected for the slave drives, they can be operated with free-running in "jog" and "positioning" operating modes.

The "DriveSync via fieldbus" application module has the following features:

- Guided startup and extensive diagnostic functions.
- Very similar to "extended positioning via bus."
- One program module for the master and slave drive.
- The selected IPOS^{plus}® encoder source is also effective in synchronous operation.
- The master value for the "synchronous operation" mode can be adjusted.
- A mechanical vertical shaft can be replaced by transferring the virtual master value via an SBus connection.
- Endless rotation is supported by the modulo function.



Four operating modes are available for controlling the application:

- Jog mode
- Reference travel
- Positioning mode
- Synchronous operation
 - The electrical connection of the master/slave can be made using the X14 encoder connection or an SBus connection.
 - If the SBus connection is used, the content of the send object can be adjusted.
 - Time or position-related sequence of motion for synchronization processes.
 - The startup cycle process can also be started with interrupt control.

- **Sensor-based positioning**

This application module is used to position the drive using an external sensor signal plus an adjustable remaining distance. This application module is especially suitable for applications in the following industrial sectors:

- Materials handling
 - Trolleys
 - Hoists
 - Rail vehicles
- Logistics
 - Storage and retrieval units
 - Transverse carriages



1.5 MOVITOOLS® operating software

Description

MOVITOOLS® is a program package comprising SHELL, SCOPE and the IPOS^{plus}® compiler. You can use MOVITOOLS® to address the MOVIDRIVE® MDX60B/61B and MOVIDRIVE® compact unit series.

- SHELL can be used to start up the drive and set its parameters quickly and easily.
- SCOPE provides extensive oscilloscope functions for drive diagnostics.
- IPOS^{plus}® compiler provides a user-friendly way of writing programs for applications in a high-level language.
- The assembler enables you to write programs directly on the machine.
- The device status shows you the status of the connected unit.

Various application modules, such as table positioning, are already stored in MOVITOOLS® as IPOS^{plus}® programs and can be activated using the application version units.

MOVITOOLS® is supplied on a CD-ROM and can also be downloaded from the SEW homepage (<http://www.sew-eurodrive.de>). MOVITOOLS® can be operated with the following operating systems:

- Windows® 95
- Windows® 98
- Windows NT® 4.0
- Windows® 2000
- Windows® Me
- Windows® XP

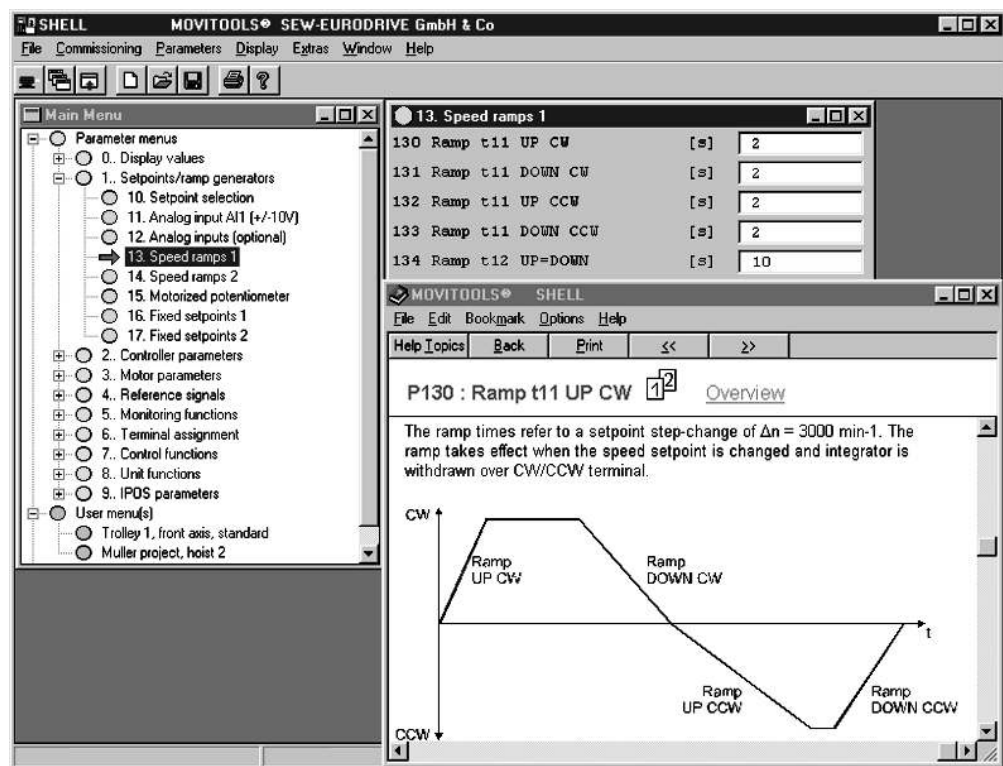
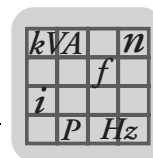

Figure 7: MOVITOOLS® window

02719AEN



2 Technical Data and Dimension Drawings

2.1 CE marking, UL approval and unit designation

CE marking

- Low voltage directive
MOVIDRIVE® *compact* drive inverters comply with the regulations of the Low Voltage Directive 73/23/EEC.
- Electromagnetic compatibility (EMC)
MOVIDRIVE® *compact* drive inverters are designed for use as components for installation in machines and systems. They comply with the EMC product standard EN 61800-3 "Variable-speed electrical drives." Provided the installation instructions are complied with, they satisfy the appropriate requirements for CE marking of the entire machine/system in which they are installed, on the basis of the EMC Directive 89/336/EEC.
MOVIDRIVE® *compact* drive inverters size 1 and 2 are equipped with a line filter as standard. These units comply with class A limit to EN 55011 and EN 55014 on the line side without further measures.



The CE mark on the nameplate indicates conformity with the Low Voltage Directive 73/23/EEC and the EMC Directive 89/336/EEC. We can provide a copy of the declaration of conformity on request.

UL / cUL / GOST-R

UL, cUL approval (USA) and the GOST-R certificate (Russia) have been approved for the MOVIDRIVE® *compact* unit series. cUL is equivalent to CSA approval.

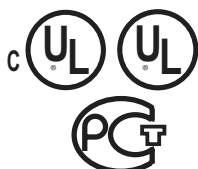

C-Tick



C-Tick approval has been granted for the entire MOVIDRIVE® *compact* unit series. C-Tick certifies conformity with ACA (Australian Communications Authority) standards.

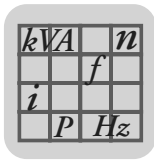

Sample unit designation

MCV 41 A 0055 - 5 A 3 - 4 - 00

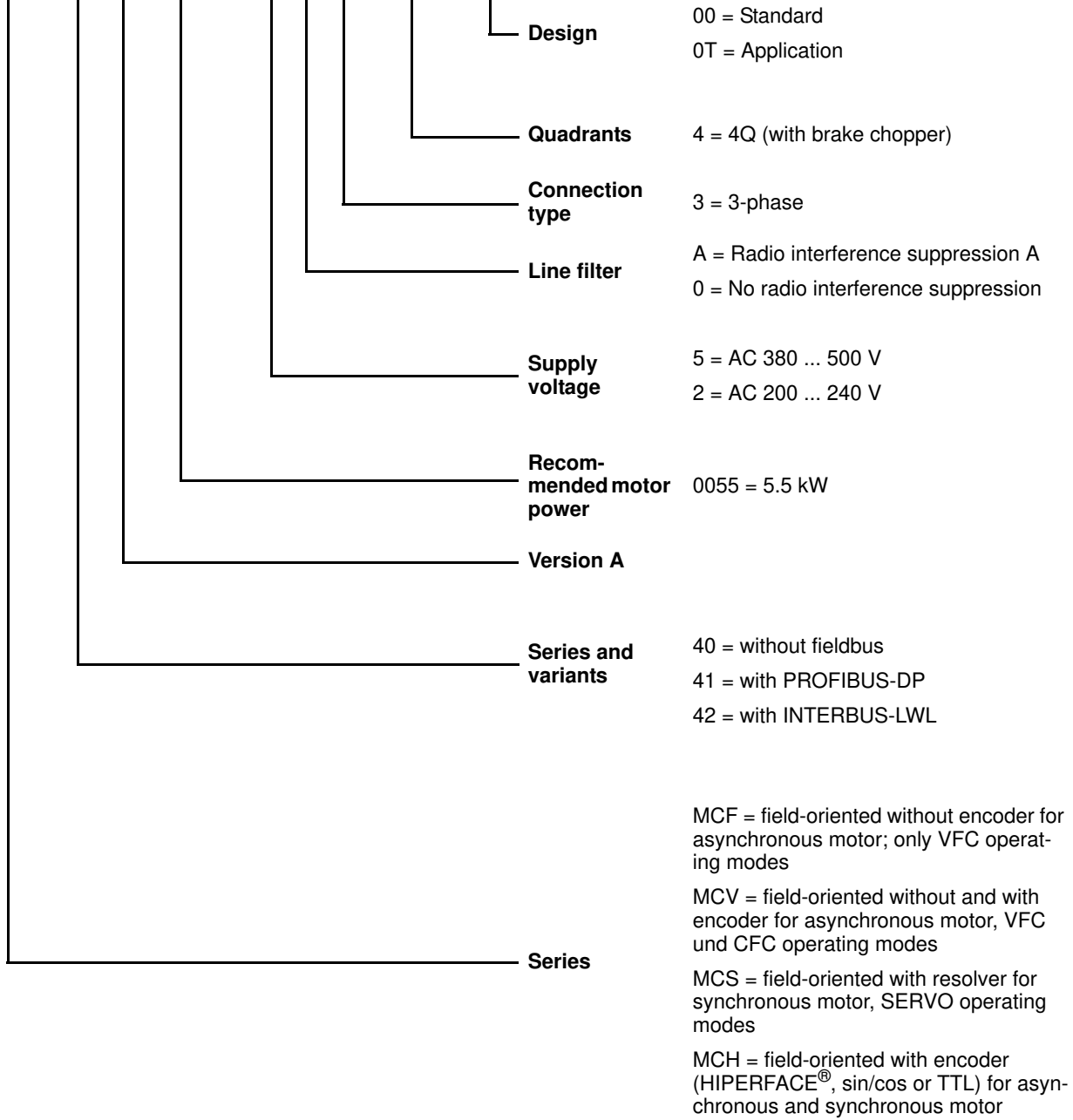

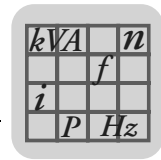

2.2 General technical data

The following table lists the technical data applicable to all MOVIDRIVE® compact drive inverters, regardless of their type, version, size and power rating.

MOVIDRIVE® compact	All sizes
Interference immunity	Complies with EN 61800-3
Interference emission with EMC-compliant installation	Sizes 1 to 5: <ul style="list-style-type: none"> • Comply with EN 61800-3 • According to class B limit to EN 55011 and EN 55014 Sizes 1 and 2: <ul style="list-style-type: none"> • Comply with class A limit to EN 55011 and EN 55014 on the line side without further measures
Ambient temperature ϑ_U Derating ambient temperature Climate class	0 °C...+50 °C when $I_D = 100\% I_N$ and $f_{PWM} = 4$ kHz 0 °C...+40 °C when $I_D = 125\% I_N$ and $f_{PWM} = 4$ kHz 0 °C...+40 °C when $I_D = 100\% I_N$ and $f_{PWM} = 8$ kHz Derating: <ul style="list-style-type: none"> • 2.5 % I_N per K between 40 °C - 50 °C • 3.5 % I_N per K between 50 °C - 60 °C EN 60721-3-3, class 3K3
Storage temperature¹⁾ ϑ_L	-25 °C...+70 °C (EN 60721-3-3, class 3K3) DBG keypad: -20 °C...+60 °C
Cooling type (DIN 51751)	Forced cooling Temperature-controlled fan, response threshold at $\vartheta = 45$ °C
Enclosure Sizes 1 to 3 EN 60529 Sizes 4 and 5 (NEMA 1)	IP20 IP00 (power connections); IP10 with mounted plexiglas cover supplied as standard
Operating mode	Continuous operation with 50 % overload capacity
Overvoltage category	III according to IEC 60664-1 (VDE 0110-1)
Pollution class	2 according to IEC 60664-1 (VDE 0110-1)
Installation altitude	Up to $h \leq 1,000$ m there are no restrictions. At $h \geq 1,000$ m and above the following restrictions apply: <ul style="list-style-type: none"> • From 1,000 m to max. 4,000 m: <ul style="list-style-type: none"> – I_N reduction by 1% per 100 m (330 ft) • From 2,000 m to max. 4,000 m: <ul style="list-style-type: none"> – AC 230 V units: V_N reduction by AC 3 V per 100 m – AC 500 V units: V_N reduction by AC 6 V per 100 m Over 2,000 m only overvoltage class 2; external measures required for overvoltage class 3. Overvoltage classes according to DIN VDE 0110-1.

1) In case of long-term storage, the unit must be connected to the mains voltage for at least 5 minutes every two years, otherwise the unit's service life may be reduced.

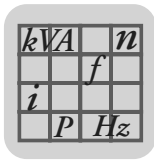

2.3 MOVIDRIVE® compact MC_4_A...-5_3 (AC 400/500 V units)

Size 1



02570AXX

MOVIDRIVE® compact		0015-5A3-4-0_	0022-5A3-4-0_	0030-5A3-4-0_	0040-5A3-4-0_
INPUT					
Supply voltage	V_{mains}	3 × AC 380 V –10 % ... 3 × AC 500 V +10 %			
Supply frequency	f_{mains}	50 Hz ... 60 Hz ±5 %			
Rated mains current ¹⁾ I_{mains}	100 % (when $V_{\text{mains}} = 3 \times \text{AC } 400 \text{ V}$) 125%	AC 3.6 A AC 4.5 A	AC 5.0 A AC 6.2 A	AC 6.3 A AC 7.9 A	AC 8.6 A AC 10.7 A
OUTPUT					
Apparent output power ²⁾ S_{N}	(when $V_{\text{mains}} = 3 \times \text{AC } 400...500 \text{ V}$)	2.8 kVA	3.8 kVA	4.9 kVA	6.6 kVA
Rated output current ¹⁾ I_{N}	(when $V_{\text{mains}} = 3 \times \text{AC } 400 \text{ V}$)	AC 4 A	AC 5.5 A	AC 7 A	AC 9.5 A
Current limitation	I_{max}	Motor and regenerative 150 % I_{N} , duration depending on the capacity utilization			
Internal current limitation		$I_{\text{max}} = 0...150 \%$ can be set in menu (P303 / P313)			
Minimum permitted braking resistance value (4Q operation)	R_{BRmin}	68 Ω			
Output voltage	V_{A}	Max. V_{mains}			
PWM frequency	f_{PWM}	Following values can be set: 4/8/12/16 kHz			
Speed range / resolution	$n_{\text{A}} / \Delta n_{\text{A}}$	–5500 ... 0 ... +5500 min ⁻¹ / 0.2 min ⁻¹ across the entire range			
GENERAL INFORMATION					
Power loss at P_{N}	P_{Vmax}	85 W	105 W	130 W	180 W
Cooling air consumption		40 m ³ /h			
Weight		2.8 kg			
Dimensions	$W \times H \times D$	MCF/MCV/MCS: 105 × 315 × 155 mm MCH: 105 × 315 × 161 mm			

1) When $V_{\text{mains}} = 3 \times \text{AC } 500 \text{ V}$, the mains currents and output currents must be reduced by 20 % compared to the rated data.

2) The power data applies to $f_{\text{PWM}} = 4 \text{ kHz}$ (factory setting for VFC operating modes).

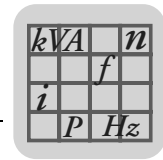

MCF4_A standard version (VFC)	0015-5A3-4-00	0022-5A3-4-00	0030-5A3-4-00	0040-5A3-4-00
Part number MCF40A (without fieldbus)	826 738 3	826 739 1	826 740 5	826 741 3
Part number MCF41A (with PROFIBUS-DP)	826 835 5	826 836 3	826 837 1	826 838 X
MCF4_A application version (VFC)	0015-5A3-4-0T	0022-5A3-4-0T	0030-5A3-4-0T	0040-5A3-4-0T
Part number MCF40A (without fieldbus)	827 426 6	827 427 4	827 428 2	827 429 0
Part number MCF41A (with PROFIBUS-DP)	827 449 5	827 450 9	827 451 7	827 452 5
Constant load Recommended motor power P_{Mot}	1.5 kW	2.2 kW	3.0 kW	4.0 kW
Variable torque load or constant load without overload Recommended motor power P_{Mot}	2.2 kW	3.0 kW	4.0 kW	5.5 kW
Continuous output current = 125% I_N I_D (when $V_{mains} = 3 \times AC\ 400\ V$ and $f_{PWM} = 4\ kHz$)	AC 5 A	AC 6.9 A	AC 8.8 A	AC 11.9 A

MCV4_A standard version (VFC/CFC)	0015-5A3-4-00	0022-5A3-4-00	0030-5A3-4-00	0040-5A3-4-00
Part number MCV40A (without fieldbus)	826 908 4	826 909 2	826 910 6	826 911 4
Part number MCV41A (with PROFIBUS-DP)	826 928 9	826 929 7	826 930 0	826 931 9
MCV4_A application version (VFC/CFC)	0015-5A3-4-0T	0022-5A3-4-0T	0030-5A3-4-0T	0040-5A3-4-0T
Part number MCV40A (without fieldbus)	827 472 X	827 473 8	827 474 6	827 475 4
Part number MCV41A (with PROFIBUS-DP)	827 495 9	827 496 7	827 497 5	827 498 3
VFC operating mode	Recommended motor power → MCF4_A			
CFC operating mode ($f_{PWM} = 8\ kHz$) Continuous output current = 100% I_N I_D Recommended motor power	AC 4 A → section CFC motor selection	AC 5.5 A	AC 7 A	AC 9.5 A

MCS4_A standard version (SERVO)	0015-5A3-4-00	0022-5A3-4-00	0030-5A3-4-00	0040-5A3-4-00
Part number MCS40A (without fieldbus)	827 060 0	827 061 9	827 062 7	827 063 5
Part number MCS41A (with PROFIBUS-DP)	827 077 5	827 078 3	827 079 1	827 080 5
MCS4_A application version (SERVO)	0015-5A3-4-0T	0022-5A3-4-0T	0030-5A3-4-0T	0040-5A3-4-0T
Part number MCS40A (without fieldbus)	827 518 1	827 519 X	827 520 3	827 521 1
Part number MCS41A (with PROFIBUS-DP)	827 541 6	827 542 4	827 543 2	827 544 0
SERVO operating mode ($f_{PWM} = 8\ kHz$) Continuous output current = 100% I_N I_D Recommended motor power	AC 4 A → section SERVO motor selection	AC 5.5 A	AC 7 A	AC 9.5 A

MCH4_A standard version (VFC/CFC/SERVO)	0015-5A3-4-00	0022-5A3-4-00	0030-5A3-4-00	0040-5A3-4-00
Part number MCH40A (without fieldbus)	827 603 X	827 604 8	827 605 6	827 606 4
Part number MCH41A (with PROFIBUS-DP)	827 649 8	827 650 1	827 651 X	827 652 8
Part number MCH42A (with INTERBUS-LWL)	827 565 3	827 566 1	827 567 X	827 568 8
MCH4_A application version (VFC/CFC/SERVO)	0015-5A3-4-0T	0022-5A3-4-0T	0030-5A3-4-0T	0040-5A3-4-0T
Part number MCH40A (without fieldbus)	827 626 9	827 627 7	827 628 5	827 629 3
Part number MCH41A (with PROFIBUS-DP)	827 672 2	827 673 0	827 674 9	827 675 7
Part number MCH42A (with INTERBUS-LWL)	827 158 5	827 159 3	827 160 7	827 161 5
VFC operating mode	Recommended motor power → MCF4_A			
CFC/SERVO operating mode ($f_{PWM} = 8\ kHz$) Continuous output current = 100% I_N I_D Recommended motor power	AC 4 A → section CFC/SERVO motor selection	AC 5.5 A	AC 7 A	AC 9.5 A

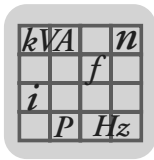

Size 2



02571AXX

MOVIDRIVE® compact		0055-5A3-4-0_	0075-5A3-4-0_	0110-5A3-4-0_
INPUT				
Supply voltage	V_{mains}	3 × AC 380 V –10 % ... 3 × AC 500 V +10 %		
Supply frequency	f_{mains}	50 Hz ... 60 Hz ±5 %		
Rated mains current ¹⁾ I_{mains} (when $V_{\text{mains}} = 3 \times \text{AC } 400 \text{ V}$)	100 %	AC 11.3 A	AC 14.4 A	AC 21.6 A
	125 %	AC 14.1 A	AC 18.0 A	AC 27.0 A
OUTPUT				
Apparent output power ²⁾ S_N (when $V_{\text{mains}} = 3 \times \text{AC } 400\text{...}500 \text{ V}$)		8.7 kVA	11.2 kVA	16.8 kVA
Rated output current ¹⁾ I_N (when $V_{\text{mains}} = 3 \times \text{AC } 400 \text{ V}$)		AC 12.5 A	AC 16 A	AC 24 A
Current limitation	I_{max}	Motor and regenerative 150 % I_N , duration depending on the capacity utilization		
Internal current limitation		$I_{\text{max}} = 0\text{...}150 \%$ can be set in menu (P303 / P313)		
Minimum permitted braking resistance value (4Q operation)	R_{BRmin}	47 Ω		22 Ω
Output voltage	V_A	Max. V_{mains}		
PWM frequency	f_{PWM}	Following values can be set: 4/8/12/16 kHz		
Speed range / resolution	$n_A / \Delta n_A$	–5500 ... 0 ... +5500 min^{-1} / 0.2 min^{-1} across the entire range		
GENERAL INFORMATION				
Power loss at P_N	$P_{V\text{max}}$	220 W	290 W	400 W
Cooling air consumption		80 m^3/h		
Weight		5.9 kg		
Dimensions	$W \times H \times D$	MCF/MCV/MCS: 130 × 335 × 207 mm MCH: 130 × 335 × 213 mm		

1) When $V_{\text{mains}} = 3 \times \text{AC } 500 \text{ V}$, the mains currents and output currents must be reduced by 20 % compared to the rated data.

2) The power data applies to $f_{\text{PWM}} = 4 \text{ kHz}$ (factory setting for VFC operating modes).

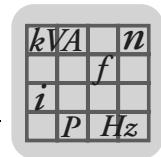

MCF4_A standard version (VFC)	0055-5A3-4-00	0075-5A3-4-00	0110-5A3-4-00
Part number MCF40A (without fieldbus)	826 742 1	826 743 X	826 744 8
Part number MCF41A (with PROFIBUS-DP)	826 839 8	826 840 1	826 841 X
MCF4_A application version (VFC)	0055-5A3-4-0T	0075-5A3-4-0T	0110-5A3-4-0T
Part number MCF40A (without fieldbus)	827 430 4	827 431 2	827 432 0
Part number MCF41A (with PROFIBUS-DP)	827 453 3	827 454 1	827 455 X
<p>Constant load Recommended motor power P_{Mot}</p>	5.5 kW	7.5 kW	11 kW
<p>Variable torque load or constant load without overload Recommended motor power P_{Mot}</p>	7.5 kW	11 kW	15 kW
Continuous output current = 125% I_N I_D (when $V_{mains} = 3 \times AC\ 400\ V$ and $f_{PWM} = 4\ kHz$)	AC 15.6 A	AC 20.0 A	AC 30.0 A

MCV4_A standard version (VFC/CFC)	0055-5A3-4-00	0075-5A3-4-00	0110-5A3-4-00
Part number MCV40A (without fieldbus)	826 912 2	826 913 0	826 914 9
Part number MCV41A (with PROFIBUS-DP)	826 932 7	826 933 5	826 934 3
MCV4_A application version (VFC/CFC)	0055-5A3-4-0T	0075-5A3-4-0T	0110-5A3-4-0T
Part number MCV40A (without fieldbus)	827 476 2	827 477 0	827 478 9
Part number MCV41A (with PROFIBUS-DP)	827 499 1	827 500 9	827 501 7
VFC operating mode	Recommended motor power → MCF4_A		
CFC operating mode ($f_{PWM} = 8\ kHz$) Continuous output current = 100% I_N I_D Recommended motor power	AC 12.5 A → section CFC motor selection	AC 16 A	AC 24 A

MCS4_A standard version (SERVO)	0055-5A3-4-00	0075-5A3-4-00	0110-5A3-4-00
Part number MCS40A (without fieldbus)	827 064 3	827 065 1	827 066 X
Part number MCS41A (with PROFIBUS-DP)	827 081 3	827 082 1	827 083 X
MCS4_A application version (SERVO)	0055-5A3-4-0T	0075-5A3-4-0T	0110-5A3-4-0T
Part number MCS40A (without fieldbus)	827 522 X	827 523 8	827 524 6
Part number MCS41A (with PROFIBUS-DP)	827 545 9	827 546 7	827 547 5
SERVO operating mode ($f_{PWM} = 8\ kHz$) Continuous output current = 100% I_N I_D Recommended motor power	AC 12.5 A → section SERVO motor selection	AC 16 A	AC 24 A

MCH4_A standard version (VFC/CFC/SERVO)	0055-5A3-4-00	0075-5A3-4-00	0110-5A3-4-00
Part number MCH40A (without fieldbus)	827 607 2	827 608 0	827 609 9
Part number MCH41A (with PROFIBUS-DP)	827 653 6	827 654 4	827 655 2
Part number MCH42A (with INTERBUS-LWL)	827 569 6	827 570 X	827 571 8
MCH4_A application version (VFC/CFC/SERVO)	0055-5A3-4-0T	0075-5A3-4-0T	0110-5A3-4-0T
Part number (withot fieldbus)	827 630 7	827 631 5	827 632 3
Part number (with PROFIBUS-DP)	827 676 5	827 677 3	827 678 1
Part number (with INTERBUS-LWL)	827 162 3	827 163 1	827 164 X
VFC operating mode	Recommended motor power → MCF4_A		
CFC/SERVO operating mode ($f_{PWM} = 8\ kHz$) Continuous output current = 100% I_N I_D Recommended motor power	AC 12.5 A → section CFC/SERVO motor selection	AC 16 A	AC 24 A

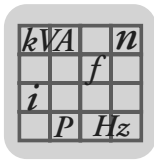

Size 3



02572AXX

MOVIDRIVE® compact		0150-503-4-0_	0220-503-4-0_	0300-503-4-0_
INPUT				
Supply voltage	V_{mains}	3 × AC 380 V –10 % ... 3 × AC 500 V +10 %		
Supply frequency	f_{mains}	50 Hz ... 60 Hz ±5 %		
Rated mains current ¹⁾	I_{mains}	100 % AC 28.8 A	AC 41.4 A	AC 54 A
(when $V_{\text{mains}} = 3 \times \text{AC } 400 \text{ V}$)	125%	AC 36 A	AC 51.7 A	AC 67.5 A
OUTPUT				
Apparent output power ²⁾	S_{N}	22.2 kVA	31.9 kVA	41.6 kVA
(when $V_{\text{mains}} = 3 \times \text{AC } 400 \dots 500 \text{ V}$)				
Rated output current ¹⁾	I_{N}	AC 32 A	AC 46 A	AC 60 A
(when $V_{\text{mains}} = 3 \times \text{AC } 400 \text{ V}$)				
Current limitation	I_{max}	Motor and regenerative 150 % I_{N} , duration depending on the capacity utilization		
Internal current limitation		$I_{\text{max}} = 0 \dots 150 \%$ can be set in menu (P303 / P313)		
Minimum permitted braking resistance value (4Q operation)	R_{BRmin}	15 Ω		12 Ω
Output voltage	V_{A}	Max. V_{mains}		
PWM frequency	f_{PWM}	Following values can be set: 4/8/12/16 kHz		
Speed range / resolution	$n_{\text{A}} / \Delta n_{\text{A}}$	–5500 ... 0 ... +5500 min ^{–1} / 0.2 min ^{–1} across the entire range		
GENERAL INFORMATION				
Power loss at P_{N}	P_{Vmax}	550 W	750 W	950 W
Cooling air consumption		180 m ³ /h		
Weight		14.3 kg		
Dimensions	$W \times H \times D$	MCF/MCV/MCS:	200 × 465 × 227 mm	MCH:
			200 × 465 × 233 mm	

1) When $V_{\text{mains}} = 3 \times \text{AC } 500 \text{ V}$, the mains currents and output currents must be reduced by 20 % compared to the rated data.

2) The power data applies to $f_{\text{PWM}} = 4 \text{ kHz}$ (factory setting for VFC operating modes).

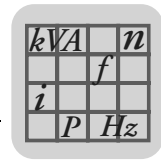

MCF4_A standard version (VFC)	0150-503-4-00	0220-503-4-00	0300-503-4-00
Part number MCF40A (without fieldbus)	826 745 6	826 746 4	826 747 2
Part number MCF41A (with PROFIBUS-DP)	826 842 8	826 843 6	826 844 4
MCF4_A application version (VFC)	0150-503-4-0T	0220-503-4-0T	0300-503-4-0T
Part number MCF40A (without fieldbus)	827 433 9	827 434 7	827 435 5
Part number MCF41A (with PROFIBUS-DP)	827 456 8	827 457 6	827 458 4
 Constant load Recommended motor power P_{Mot}	15 kW	22 kW	30 kW
 Variable torque load or constant load without overload Recommended motor power P_{Mot}	22 kW	30 kW	37 kW
Continuous output current = 125% I_N I_D (when $V_{mains} = 3 \times AC\ 400\ V$ and $f_{PWM} = 4\ kHz$)	AC 40.0 A	AC 57.5 A	AC 75.0 A

MCV4_A standard version (VFC/CFC)	0150-503-4-00	0220-503-4-00	0300-503-4-00
Part number MCV40A (without fieldbus)	826 915 7	826 916 5	826 917 3
Part number MCV41A (with PROFIBUS-DP)	826 935 1	826 936 X	826 937 8
MCV4_A application version (VFC/CFC)	0150-503-4-0T	0220-503-4-0T	0300-503-4-0T
Part number MCV40A (without fieldbus)	827 479 7	827 480 0	827 481 9
Part number MCV41A (with PROFIBUS-DP)	827 502 5	827 503 3	827 504 1
VFC operating mode	Recommended motor power → MCF4_A		
CFC operating mode ($f_{PWM} = 8\ kHz$) Continuous output current = 100% I_N I_D Recommended motor power	AC 32 A → section CFC motor selection	AC 46 A	AC 60 A

MCS4_A standard version (SERVO)	0150-503-4-00	0220-503-4-00	0300-503-4-00
Part number MCS40A (without fieldbus)	827 067 8	827 068 6	827 069 4
Part number MCS41A (with PROFIBUS-DP)	827 084 8	827 085 6	827 086 4
MCS4_A application version (SERVO)	0150-503-4-0T	0220-503-4-0T	0300-503-4-0T
Part number MCS40A (without fieldbus)	827 525 4	827 526 2	827 527 0
Part number MCS41A (with PROFIBUS-DP)	827 548 3	827 549 1	827 550 5
SERVO operating mode ($f_{PWM} = 8\ kHz$) Continuous output current = 100% I_N I_D Recommended motor power	AC 32 A → section SERVO motor selection	AC 46 A	AC 60 A

MCH4_A standard version (VFC/CFC/SERVO)	0150-503-4-00	0220-503-4-00	0300-503-4-00
Part number MCH40A (without fieldbus)	827 610 2	827 611 0	827 612 9
Part number MCH41A (with PROFIBUS-DP)	827 656 0	827 657 9	827 658 7
Part number MCH42A (with INTERBUS-LWL)	827 572 6	827 573 4	827 574 2
MCH4_A application version (VFC/CFC/SERVO)	0150-503-4-0T	0220-503-4-0T	0300-503-4-0T
Part number MCH40A (without fieldbus)	827 633 1	827 634 X	827 635 8
Part number MCH41A (with PROFIBUS-DP)	827 679 X	827 680 3	827 681 1
Part number MCH42A (with INTERBUS-LWL)	827 165 8	827 166 6	827 167 4
VFC operating mode	Recommended motor power → MCF4_A		
CFC/SERVO operating mode ($f_{PWM} = 8\ kHz$) Continuous output current = 100% I_N I_D Recommended motor power	AC 32 A → section CFC/SERVO motor selection	AC 46 A	AC 60 A

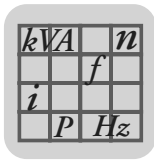

Technical Data and Dimension Drawings

MOVIDRIVE® compact MC_4_A...-5_3 (AC 400/500 V units)

Size 4



02573AXX

MOVIDRIVE® compact		0370-503-4-0_	0450-503-4-0_
INPUT			
Supply voltage	V_{mains}	3 × AC 380 V -10 % ... 3 × AC 500 V +10 %	
Supply frequency	f_{mains}	50 Hz ... 60 Hz ±5 %	
Rated mains current ¹⁾ I_{mains}	100 % (when $V_{\text{mains}} = 3 \times \text{AC } 400 \text{ V}$) 125%	AC 65.7 A AC 81.9 A	AC 80.1 A AC 100.1 A
OUTPUT			
Apparent output power ²⁾ S_N	(when $V_{\text{mains}} = 3 \times \text{AC } 400...500 \text{ V}$)	51.1 kVA	62.3 kVA
Rated output current ¹⁾ I_N	(when $V_{\text{mains}} = 3 \times \text{AC } 400 \text{ V}$)	AC 73 A	AC 89 A
Current limitation	I_{max}	Motor and regenerative 150 % I_N , duration depending on the capacity utilization	
Internal current limitation		$I_{\text{max}} = 0...150 \%$ can be set in menu (P303 / P313)	
Minimum permitted braking resistance value (4Q operation)	R_{BRmin}	6 Ω	
Output voltage	V_A	Max. V_{mains}	
PWM frequency	f_{PWM}	Following values can be set: 4/8/12/16 kHz	
Speed range / resolution	$n_A / \Delta n_A$	-5500 ... 0 ... +5500 min ⁻¹ / 0.2 min ⁻¹ across the entire range	
GENERAL INFORMATION			
Power loss at P_N	$P_{V\text{max}}$	1200 W	1450 W
Cooling air consumption		180 m ³ /h	
Weight		26.3 kg	
Dimensions	$W \times H \times D$	MCF/MCV/MCS: 280 × 522 × 227 mm MCH: 280 × 522 × 233 mm	

1) When $V_{\text{mains}} = 3 \times \text{AC } 500 \text{ V}$, the mains currents and output currents must be reduced by 20 % compared to the rated data.

2) The power data applies to $f_{\text{PWM}} = 4 \text{ kHz}$ (factory setting for VFC operating modes).

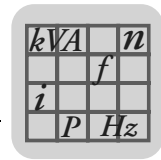

MCF4_A standard version (VFC)	0370-503-4-00	0450-503-4-00
Part number MCF40A (without fieldbus)	826 748 0	826 749 9
Part number MCF41A (with PROFIBUS-DP)	826 845 2	826 846 0
MCF4_A application version (VFC)	0370-503-4-0T	0450-503-4-0T
Part number MCF40A (without fieldbus)	827 436 3	827 437 1
Part number MCF41A (with PROFIBUS-DP)	827 459 2	827 460 6
<p>Constant load Recommended motor power P_{Mot}</p>	37 kW	45 kW
<p>Variable torque load or constant load without overload Recommended motor power P_{Mot}</p>	45 kW	55 kW
Continuous output current = 125% I_N I_D (when $V_{mains} = 3 \times AC\ 400\ V$ and $f_{PWM} = 4\ kHz$)	AC 91 A	AC 111 A

MCV4_A standard version (VFC/CFC)	0370-503-4-00	0450-503-4-00
Part number MCV40A (without fieldbus)	826 918 1	826 919 X
Part number MCV41A (with PROFIBUS-DP)	826 938 6	826 939 4
MCV4_A application version (VFC/CFC)	0370-503-4-0T	0450-503-4-0T
Part number MCV40A (without fieldbus)	827 482 7	827 483 5
Part number MCV41A (with PROFIBUS-DP)	827 505 X	827 506 8
VFC operating mode	Recommended motor power → MCF4_A	
CFC operating mode ($f_{PWM} = 8\ kHz$) Continuous output current = 100% I_N I_D	AC 73 A	AC 89 A
Recommended motor power	→ section CFC motor selection	

MCS4_A standard version (SERVO)	0370-503-4-00	0450-503-4-00
Part number MCS40A (without fieldbus)	827 070 8	
Part number MCS41A (with PROFIBUS-DP)	827 087 2	
MCS4_A application version (SERVO)	0370-503-4-0T	0450-503-4-0T
Part number MCS40A (without fieldbus)	827 528 9	827 529 7
Part number MCS41A (with PROFIBUS-DP)	827 551 3	827 552 1
SERVO operating mode ($f_{PWM} = 8\ kHz$) Continuous output current = 100% I_N I_D	AC 73 A	AC 89 A
Recommended motor power	→ section SERVO motor selection	

MCH4_A standard version (VFC/CFC/SERVO)	0370-503-4-00	0450-503-4-00
Part number MCH40A (without fieldbus)	827 613 7	827 614 5
Part number MCH41A (with PROFIBUS-DP)	827 659 5	827 660 9
Part number MCH42A (with INTERBUS-LWL)	827 575 0	827 576 9
MCH4_A application version (VFC/CFC/SERVO)	0370-503-4-0T	0450-503-4-0T
Part number MCH40A (without fieldbus)	827 636 6	827 637 4
Part number MCH41A (with PROFIBUS-DP)	827 682 X	827 683 8
Part number MCH42A (with INTERBUS-LWL)	827 168 2	827 169 0
VFC operating mode	Recommended motor power → MCF4_A	
CFC/SERVO operating mode ($f_{PWM} = 8\ kHz$) Continuous output current = 100% I_N I_D	AC 73 A	AC 89 A
Recommended motor power	→ section CFC/SERVO motor selection	

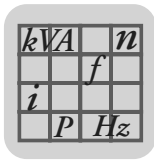

Size 5



02574AXX

MOVIDRIVE® compact		0550-503-4-0_	0750-503-4-0_
INPUT			
Supply voltage	V_{mains}	3 × AC 380 V -10 % ... 3 × AC 500 V +10 %	
Supply frequency	f_{mains}	50 Hz ... 60 Hz ±5 %	
Rated mains current ¹⁾	I_{mains}	100 % AC 94.5 A	AC 117.0 A
(when $V_{\text{mains}} = 3 \times \text{AC } 400 \text{ V}$)	125%	AC 118.1 A	AC 146.3 A
OUTPUT			
Apparent output power ²⁾	S_N	73.5 kVA	91.0 kVA
(when $V_{\text{mains}} = 3 \times \text{AC } 400...500 \text{ V}$)			
Rated output current ¹⁾	I_N	AC 105 A	AC 130 A
(when $V_{\text{mains}} = 3 \times \text{AC } 400 \text{ V}$)			
Current limitation	I_{max}	Motor and regenerative 150% I_N , duration depending on capacity utilization	
Internal current limitation		$I_{\text{max}} = 0...150 \%$ can be set in menu (P303 / P313)	
Minimum permitted braking resistance value (4Q operation)	R_{BRmin}	6 Ω	4 Ω
Output voltage	V_A	Max. V_{mains}	
PWM frequency	f_{PWM}	Following values can be set: 4/8/12/16 kHz	
Speed range / resolution	$n_A / \Delta n_A$	-5500 ... 0 ... +5500 min ⁻¹ / 0.2 min ⁻¹ across the entire range	
GENERAL INFORMATION			
Power loss at P_N	P_{Vmax}	1700 W	2000 W
Cooling air consumption		360 m ³ /h	
Weight		34.3 kg	
Dimensions	$W \times H \times D$	280 × 610 × 330 mm	

1) When $V_{\text{mains}} = 3 \times \text{AC } 500 \text{ V}$, the mains currents and output currents must be reduced by 20 % compared to the rated data.

2) The power data applies to $f_{\text{PWM}} = 4 \text{ kHz}$ (factory setting for VFC operating modes).

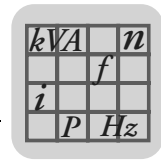

MCF4_A standard version (VFC)	0550-503-4-00	0750-503-4-00
Part number MCF40A (without fieldbus)	826 750 2	826 751 0
Part number MCF41A (with PROFIBUS-DP)	826 847 9	826 848 7
MCF4_A application version (VFC)	0550-503-4-0T	0750-503-4-0T
Part number MCF40A (without fieldbus)	827 438 X	827 439 8
Part number MCF41A (with PROFIBUS-DP)	827 461 4	827 462 2
<p>Constant load Recommended motor power P_{Mot}</p>	55 kW	75 kW
<p>Variable torque load or constant load without overload Recommended motor power P_{Mot}</p>	75 kW	90 kW
Continuous output current = 125% I_N I_D (when $V_{ains} = 3 \times AC\ 400\ V$ and $f_{PWM} = 4\ kHz$)	AC 131 A	AC 162 A

MCV4_A standard version (VFC/CFC)	0550-503-4-00	0750-503-4-00
Part number MCV40A (without fieldbus)	826 920 3	826 921 1
Part number MCV41A (with PROFIBUS-DP)	826 940 8	826 941 6
MCV4_A application version (VFC/CFC)	0550-503-4-0T	0750-503-4-0T
Part number MCV40A (without fieldbus)	827 484 3	827 485 1
Part number MCV41A (with PROFIBUS-DP)	827 507 6	827 508 4
VFC operating mode	Recommended motor power → MCF4_A	
CFC operating mode ($f_{PWM} = 8\ kHz$) Continuous output current = 100% I_N I_D Recommended motor power	AC 105 A → section CFC motor selection	AC 130 A

MCS4_A standard version (SERVO)	0550-503-4-00	0750-503-4-00
Part number MCS40A (without fieldbus)		
Part number MCS41A (with PROFIBUS-DP)		
MCS4_A application version (SERVO)	0550-503-4-0T	0750-503-4-0T
Part number MCS40A (without fieldbus)	827 530 0	827 531 9
Part number MCS41A (with PROFIBUS-DP)	827 553 X	827 554 8
SERVO operating mode ($f_{PWM} = 8\ kHz$) Continuous output current = 100% I_N I_D Recommended motor power	AC 105 A → section SERVO motor selection	AC 130 A

MCH4_A standard version (VFC/CFC/SERVO)	0550-503-4-00	0750-503-4-00
Part number MCH40A (without fieldbus)	827 615 3	827 616 1
Part number MCH41A (with PROFIBUS-DP)	827 661 7	827 662 5
Part number MCH42A (with INTERBUS-LWL)	827 577 7	827 578 5
MCH4_A application version (VFC/CFC/SERVO)	0550-503-4-0T	0750-503-4-0T
Part number MCH40A (without fieldbus)	827 638 2	827 639 0
Part number MCH41A (with PROFIBUS-DP)	827 684 6	827 685 4
Part number MCH42A (with INTERBUS-LWL)	827 170 4	827 171 2
VFC operating mode	Recommended motor power → MCF4_A	
CFC/SERVO operating mode ($f_{PWM} = 8\ kHz$) Continuous output current = 100% I_N I_D Recommended motor power	AC 105 A → section CFC/SERVO motor selection	AC 130 A

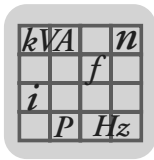
2.4 MOVIDRIVE® compact MC_4_A...-2_3 (AC 230 V units)
Size 1

02570AXX

MOVIDRIVE® compact		0015-2A3-4-0_	0022-2A3-4-0_	0037-2A3-4-0_
INPUT				
Supply voltage	V_{mains}	3 × AC 200 V –10 % ... 3 × AC 240 V +10 %		
Supply frequency	f_{mains}	50 Hz ... 60 Hz ±5 %		
Rated mains current I_{mains} (when $V_{\text{mains}} = 3 \times \text{AC } 230 \text{ V}$)	100 % 125%	AC 6.7 A AC 8.4 A	AC 7.8 A AC 9.8 A	AC 12.9 A AC 16.1 A
OUTPUT				
Apparent output power ¹⁾ (when $V_{\text{mains}} = 3 \times \text{AC } 230..240 \text{ V}$)	S_N	2.7 kVA	3.4 kVA	5.8 kVA
Rated output current (when $V_{\text{mains}} = 3 \times \text{AC } 230 \text{ V}$)	I_N	AC 7.3 A	AC 8.6 A	AC 14.5 A
Current limitation	I_{max}	Motor and regenerative 150 % I_N , duration depending on the capacity utilization		
Internal current limitation		$I_{\text{max}} = 0...150 \%$ can be set in menu (P303 / P313)		
Minimum permitted braking resistance value (4Q operation)	R_{BRmin}	27 Ω		
Output voltage	V_A	Max. V_{mains}		
PWM frequency	f_{PWM}	Following values can be set: 4/8/12/16 kHz		
Speed range / resolution	$n_A / \Delta n_A$	–5500 ... 0 ... +5500 min^{-1} / 0.2 min^{-1} across the entire range		
GENERAL INFORMATION				
Power loss at P_N	$P_{V\text{max}}$	110 W	126 W	210 W
Cooling air consumption		40 m^3/h		
Weight		2.8 kg		
Dimensions	$W \times H \times D$	MCF/MCV/MCS:105 × 315 × 155 mm MCH:105 × 315 × 161 mm		

1) The power data applies to $f_{\text{PWM}} = 4 \text{ kHz}$ (factory setting for VFC operating modes).

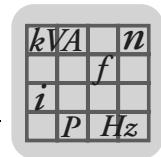

MCF4_A standard version (VFC)	0015-2A3-4-00	0022-2A3-4-00	0037-2A3-4-00
Part number MCF40A (without fieldbus)	826 752 9	826 753 7	826 754 5
Part number MCF41A (with PROFIBUS-DP)	826 853 3	826 854 1	826 855 X
MCF4_A application version (VFC)	0015-2A3-4-0T	0022-2A3-4-0T	0037-2A3-4-0T
Part number MCF40A (without fieldbus)	827 440 1	827 441 X	827 442 8
Part number MCF41A (with PROFIBUS-DP)	827 463 0	827 464 9	827 465 7
Constant load Recommended motor power P_{Mot}	1.5 kW	2.2 kW	3.7 kW
Variable torque load or constant load without overload Recommended motor power P_{Mot}	2.2 kW	3.7 kW	5.0 kW
Continuous output current = 125% I_N I_D (when $U_{mains} = 3 \times AC\ 230\ V$ and $f_{PWM} = 4\ kHz$)	AC 9.1 A	AC 10.8 A	AC 18.1 A

MCV4_A standard version (VFC/CFC)	0015-2A3-4-00	0022-2A3-4-00	0037-2A3-4-00
Part number MCV40A (without fieldbus)	826 922 X	826 923 8	826 924 6
Part number MCV41A (with PROFIBUS-DP)	826 942 4	826 943 2	826 944 0
MCV4_A application version (VFC/CFC)	0015-2A3-4-0T	0022-2A3-4-0T	0037-2A3-4-0T
Part number MCV40A (without fieldbus)	827 486 X	827 487 8	827 488 6
Part number MCV41A (with PROFIBUS-DP)	827 509 2	827 510 6	827 511 4
VFC operating mode	Recommended motor power → MCF4_A		
CFC operating mode ($f_{PWM} = 8\ kHz$) Continuous output current = 100% I_N I_D Recommended motor power	AC 7.3 A → section CFC motor selection	AC 8.6 A	AC 14.5 A

MCS4_A standard version (SERVO)	0015-2A3-4-00	0022-2A3-4-00	0037-2A3-4-00
Part number MCS40A (without fieldbus)	827 071 6	827 0724	827 073 2
Part number MCS41A (with PROFIBUS-DP)	827 088 0	827 089 9	827 090 2
MCS4_A application version (SERVO)	0015-2A3-4-0T	0022-2A3-4-0T	0037-2A3-4-0T
Part number MCS40A (without fieldbus)	827 532 7	827 533 5	827 534 3
Part number MCS41A (with PROFIBUS-DP)	827 555 6	827 556 4	827 557 2
SERVO operating mode	Recommended motor power → MCS4_A		
SERVO operating mode ($f_{PWM} = 8\ kHz$) Continuous output current = 100% I_N I_D Recommended motor power	AC 7.3 A → section SERVO motor selection	AC 8.6 A	AC 14.5 A

MCH4_A standard version (VFC/CFC)	0015-2A3-4-00	0022-2A3-4-00	0037-2A3-4-00
Part number MCH40A (without fieldbus)	827 617 X	827 618 8	827 619 6
Part number MCH41A (with PROFIBUS-DP)	827 663 3	827 664 1	827 665 X
Part number MCH42A (with INTERBUS-LWL)	827 588 2	827 589 0	827 590 4
MCH4_A application version (VFC/CFC)	0015-2A3-4-0T	0022-2A3-4-0T	0037-2A3-4-0T
Part number MCH40A (without fieldbus)	827 640 4	827 641 2	827 642 0
Part number MCH41A (with PROFIBUS-DP)	827 686 2	827 687 0	827 688 9
Part number MCH42A (with INTERBUS-LWL)	827 579 3	827 580 7	827 581 5
VFC operating mode	Recommended motor power → MCF4_A		
CFC/SERVO operating mode ($f_{PWM} = 8\ kHz$) Continuous output current = 100% I_N I_D Recommended motor power	AC 7.3 A → section CFC/SERVO motor selection	AC 8.6 A	AC 14.5 A

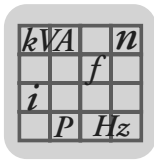

Size 2



02571AXX

MOVIDRIVE® compact	0055-2A3-4-0_	0075-2A3-4-0_
INPUT		
Supply voltage	V_{mains}	$3 \times \text{AC } 200 \text{ V} -10 \% \dots 3 \times \text{AC } 240 \text{ V} +10 \%$
Supply frequency	f_{mains}	$50 \text{ Hz} \dots 60 \text{ Hz} \pm 5 \%$
Rated mains current I_{mains} (when $V_{\text{mains}} = 3 \times \text{AC } 230 \text{ V}$)	100 % 125%	AC 19.5 A AC 24.4 A
OUTPUT		
Apparent output power ¹⁾ (when $V_{\text{mains}} = 3 \times \text{AC } 230..240 \text{ V}$)	S_N	8.8 kVA
Rated output current (when $V_{\text{mains}} = 3 \times \text{AC } 230 \text{ V}$)	I_N	AC 22 A
Current limitation	I_{max}	Motor and regenerative 150 % I_N , duration depending on the capacity utilization
Internal current limitation		$I_{\text{max}} = 0\dots 150 \%$ can be set in menu (P303 / P313)
Minimum permitted braking resistance value (4Q operation)	R_{BRmin}	12 Ω
Output voltage	V_A	Max. V_{mains}
PWM frequency	f_{PWM}	Following values can be set: 4/8/12/16 kHz
Speed range / resolution	$n_A / \Delta n_A$	$-5500 \dots 0 \dots +5500 \text{ min}^{-1} / 0.2 \text{ min}^{-1}$ across the entire range
GENERAL INFORMATION		
Power loss at P_N	$P_{V\text{max}}$	300 W
Cooling air consumption		80 m ³ /h
Weight		5.9 kg
Dimensions	$W \times H \times D$	MCF/MCV/MCS:130 × 335 × 207 mm MCH:130 × 335 × 213 mm

1) The power data applies to $f_{\text{PWM}} = 4 \text{ kHz}$ (factory setting for VFC operating modes).

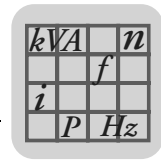

MCF4_A standard version (VFC)	0055-2A3-4-00	0075-2A3-4-00
Part number MCF40A (without fieldbus)	826 755 3	826 756 1
Part number MCF41A (with PROFIBUS-DP)	826 856 8	826 857 6
MCF4_A application version (VFC)	0055-2A3-4-0T	0075-2A3-4-0T
Part number MCF40A (without fieldbus)	827 443 6	827 444 4
Part number MCF41A (with PROFIBUS-DP)	827 466 5	827 467 3
Constant load Recommended motor power P_{Mot}	5.5 kW	7.5 kW
Variable torque load or constant load without overload Recommended motor power P_{Mot}	7.5 kW	11 kW
Continuous output current = 125% I_N I_D (when $V_{mains} = 3 \times AC\ 230\ V$ and $f_{PWM} = 4\ kHz$)	AC 27.5 A	AC 36.3 A

MCV4_A standard version (VFC/CFC)	0055-2A3-4-00	0075-2A3-4-00
Part number MCV40A (without fieldbus)	826 925 4	826 926 2
Part number MCV41A (with PROFIBUS-DP)	826 945 9	826 946 7
MCV4_A application version (VFC/CFC)	0055-2A3-4-0T	0075-2A3-4-0T
Part number MCV40A (without fieldbus)	827 489 4	827 490 8
Part number MCV41A (with PROFIBUS-DP)	827 512 2	827 513 0
VFC operating mode	Recommended motor power → MCF4_A	
CFC operating mode ($f_{PWM} = 8\ kHz$)		
Continuous output current = 100% I_N I_D	AC 22 A	AC 29 A
Recommended motor power	→ section CFC motor selection	

MCS4_A standard version (SERVO)	0055-2A3-4-00	0075-2A3-4-00
Part number MCS40A (without fieldbus)	827 074 0	827 075 9
Part number MCS41A (with PROFIBUS-DP)	827 091 0	827 092 9
MCS4_A application version (SERVO)	0055-2A3-4-0T	0075-2A3-4-0T
Part number MCS40A (without fieldbus)	827 535 1	827 536 X
Part number MCS41A (with PROFIBUS-DP)	827 558 0	827 559 9
SERVO operating mode	Recommended motor power → MCS4_A	
SERVO operating mode ($f_{PWM} = 8\ kHz$)		
Continuous output current = 100% I_N I_D	AC 22 A	AC 29 A
Recommended motor power	→ section SERVO motor selection	

MCH4_A standard version (VFC/CFC)	0055-2A3-4-00	0075-2A3-4-00
Part number MCH40A (without fieldbus)	827 620 X	827 621 8
Part number MCH41A (with PROFIBUS-DP)	827 666 8	827 667 6
Part number MCH42A (with INTERBUS-LWL)	827 591 2	827 592 0
MCH4_A application version (VFC/CFC)	0055-2A3-4-0T	0075-2A3-4-0T
Part number MCH40A (without fieldbus)	827 643 9	827 644 7
Part number MCH41A (with PROFIBUS-DP)	827 689 7	827 690 0
Part number MCH42A (with INTERBUS-LWL)	827 582 3	827 583 1
VFC operating mode	Recommended motor power → MCF4_A	
CFC/SERVO operating mode ($f_{PWM} = 8\ kHz$)		
Continuous output current = 100% I_N I_D	AC 22 A	AC 29 A
Recommended motor power	→ section CFC/SERVO motor selection	

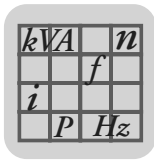
Size 3

02572AXX

MOVIDRIVE® compact		0110-203-4-0_	0150-203-4-0_
INPUT			
Supply voltage	V_{mains}	3 × AC 200 V −10 % ... 3 × AC 240 V +10 %	
Supply frequency	f_{mains}	50 Hz ... 60 Hz ±5 %	
Rated mains current I_{mains}	100 % (when $V_{\text{mains}} = 3 \times \text{AC } 230 \text{ V}$) 125%	AC 40 A AC 50 A	AC 49 A AC 61 A
OUTPUT			
Apparent output power ¹⁾	S_{N} (when $V_{\text{mains}} = 3 \times \text{AC } 230...240 \text{ V}$)	17.1 kVA	21.5 kVA
Rated output current	I_{N} (when $V_{\text{mains}} = 3 \times \text{AC } 230 \text{ V}$)	AC 42 A	AC 54 A
Current limitation	I_{max}	Motor and regenerative 150 % I_{N} , duration depending on the capacity utilization	
Internal current limitation		$I_{\text{max}} = 0...150 \%$ can be set in menu (P303 / P313)	
Minimum permitted braking resistance value (4Q operation)	R_{BRmin}	7.5 Ω	5.6 Ω
Output voltage	V_{A}	Max. V_{mains}	
PWM frequency	f_{PWM}	Following values can be set: 4/8/12/16 kHz	
Speed range / resolution	$n_{\text{A}} / \Delta n_{\text{A}}$	−5500 ... 0 ... +5500 min ^{−1} / 0.2 min ^{−1} across the entire range	
GENERAL INFORMATION			
Power loss at P_{N}	P_{Vmax}	580 W	720 W
Cooling air consumption		180 m ³ /h	
Weight		14.3 kg	
Dimensions	$W \times H \times D$	MCF/MCV/MCS: 200 × 465 × 227 mm MCH: 200 × 465 × 233 mm	

1) The power data applies to $f_{\text{PWM}} = 4 \text{ kHz}$ (factory setting for VFC operating modes).

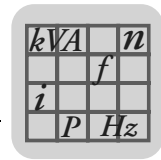

MCF4_A standard version (VFC)	0110-203-4-00	0150-203-4-00
Part number MCF40A (without fieldbus)	826 757 X	827 263 8
Part number MCF41A (with PROFIBUS-DP)	826 858 4	827 266 2
MCF4_A application version (VFC)	0110-203-4-0T	0150-203-4-0T
Part number MCF40A (without fieldbus)	827 445 2	827 446 0
Part number MCF41A (with PROFIBUS-DP)	827 468 1	827 469 X
<p>Constant load Recommended motor power P_{Mot}</p>	11 kW	15 kW
<p>Variable torque load or constant load without overload Recommended motor power P_{Mot}</p>	15 kW	22 kW
Continuous output current = 125% I_N I_D (when $U_{mains} = 3 \times AC\ 230\ V$ and $f_{PWM} = 4\ kHz$)	AC 52.5 A	AC 67.5 A

MCV4_A standard version (VFC/CFC)	0110-203-4-00	0150-203-4-00
Part number MCV40A (without fieldbus)	826 927 0	827 269 7
Part number MCV41A (with PROFIBUS-DP)	826 947 5	827 272 7
MCV4_A application version (VFC/CFC)	0110-203-4-0T	0150-203-4-0T
Part number MCV40A (without fieldbus)	827 491 6	827 492 4
Part number MCV41A (with PROFIBUS-DP)	827 514 9	827 515 7
VFC operating mode	Recommended motor power → MCF4_A	
CFC operating mode ($f_{PWM} = 8\ kHz$) Continuous output current = 100% I_N I_D	AC 42 A	AC 54 A
Recommended motor power	→ section CFC motor selection	

MCS4_A standard version (SERVO)	0110-203-4-00	0150-203-4-00
Part number MCS40A (without fieldbus)	827 076 7	827 305 7
Part number MCS41A (with PROFIBUS-DP)	827 093 7	827 308 1
MCS4_A application version (SERVO)	0110-203-4-0T	0150-203-4-0T
Part number MCS40A (without fieldbus)	827 537 8	827 538 6
Part number MCS41A (with PROFIBUS-DP)	827 560 2	827 561 0
SERVO operating mode	Recommended motor power → MCS4_A	
SERVO operating mode ($f_{PWM} = 8\ kHz$) Continuous output current = 100% I_N I_D	AC 42 A	AC 54 A
Recommended motor power	→ section SERVO motor selection	

MCH4_A standard version (VFC/CFC)	0110-203-4-00	0150-203-4-00
Part number MCH40A (without fieldbus)	827 622 6	827 623 4
Part number MCH41A (with PROFIBUS-DP)	827 668 4	827 669 2
Part number MCH42A (with INTERBUS-LWL)	827 593 9	827 594 7
MCH4_A application version (VFC/CFC)	0110-203-4-0T	0150-203-4-0T
Part number MCH40A (without fieldbus)	827 645 5	827 646 3
Part number MCH41A (with PROFIBUS-DP)	827 691 9	827 692 7
Part number MCH42A (with INTERBUS-LWL)	827 584 X	827 585 8
VFC operating mode	Recommended motor power → MCF4_A	
CFC/SERVO operating mode ($f_{PWM} = 8\ kHz$) Continuous output current = 100% I_N I_D	AC 42 A	AC 54 A
Recommended motor power	→ section CFC/SERVO motor selection	

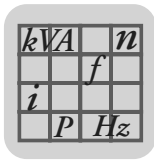

Size 4



02573AXX

MOVIDRIVE® compact		0220-203-4-0_	0300-203-4-0_
INPUT			
Supply voltage	V_{mains}	3 × AC 200 V –10 % ... 3 × AC 240 V +10 %	
Supply frequency	f_{mains}	50 Hz ... 60 Hz ±5 %	
Rated mains current (when $V_{\text{mains}} = 3 \times \text{AC } 230 \text{ V}$)	I_{mains} 100 % 125%	AC 72 A AC 90 A	AC 86 A AC 107 A
OUTPUT			
Apparent output power ¹⁾ (when $V_{\text{mains}} = 3 \times \text{AC } 230...240 \text{ V}$)	S_N	31.8 kVA	37.8 kVA
Rated output current (when $V_{\text{mains}} = 3 \times \text{AC } 230 \text{ V}$)	I_N	AC 80 A	AC 95 A
Current limitation	I_{max}	Motor and regenerative 150 % I_N , duration depending on the capacity utilization	
Internal current limitation		$I_{\text{max}} = 0...150 \%$ can be set in menu (P303 / P313)	
Minimum permitted braking resistance value (4Q operation)	R_{BRmin}	3 Ω	
Output voltage	V_A	Max. V_{mains}	
PWM frequency	f_{PWM}	Following values can be set: 4/8/12/16 kHz	
Speed range / resolution	$n_A / \Delta n_A$	–5500 ... 0 ... +5500 min ^{–1} / 0.2 min ^{–1} across the entire range	
GENERAL INFORMATION			
Power loss at P_N	$P_{V\text{max}}$	1100 W	1300 W
Cooling air consumption		180 m ³ /h	
Weight		26.3 kg	
Dimensions	$W \times H \times D$	MCF/MCV/MCS: 280 × 522 × 227 mm MCH: 280 × 522 × 233 mm	

1) The power data applies to $f_{\text{PWM}} = 4 \text{ kHz}$ (factory setting for VFC operating modes).

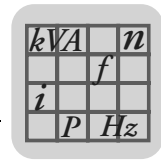

MCF4_A standard version (VFC)	0220-203-4-00	0300-203-4-00
Part number MCF40A (without fieldbus)	827 264 6	827 265 4
Part number MCF41A (with PROFIBUS-DP)	827 267 0	827 268 9
MCF4_A application version (VFC)	0220-203-4-0T	0300-203-4-0T
Part number MCF40A (without fieldbus)	827 447 9	827 448 7
Part number MCF41A (with PROFIBUS-DP)	827 470 3	827 471 1
<p>Constant load Recommended motor power P_{Mot}</p>	22 kW	30 kW
<p>Variable torque load or constant load without overload Recommended motor power P_{Mot}</p>	30 kW	37 kW
Continuous output current = 125% I_N I_D (when $V_{mains} = 3 \times AC\ 230\ V$ and $f_{PWM} = 4\ kHz$)	AC 100 A	AC 118 A

MCV4_A standard version (VFC/CFC)	0220-203-4-00	0300-203-4-00
Part number MCV40A (without fieldbus)	827 270 0	827 271 9
Part number MCV41A (with PROFIBUS-DP)	827 273 5	827 274 3
MCV4_A application version (VFC/CFC)	0220-203-4-0T	0300-203-4-0T
Part number MCV40A (without fieldbus)	827 493 2	827 494 0
Part number MCV41A (with PROFIBUS-DP)	827 516 5	827 517 3
VFC operating mode	Recommended motor power → MCF4_A	
CFC operating mode ($f_{PWM} = 8\ kHz$) Continuous output current = 100% I_N I_D	AC 80 A	AC 95 A
Recommended motor power	→ section CFC motor selection	

MCS4_A standard version (SERVO)	0220-203-4-00	0300-203-4-00
Part number MCS40A (without fieldbus)	827 306 5	827 307 3
Part number MCS41A (with PROFIBUS-DP)	827 309 X	827 310 3
MCS4_A application version (SERVO)	0220-203-4-0T	0300-203-4-0T
Part number MCS40A (without fieldbus)	827 539 4	827 540 8
Part number MCS41A (with PROFIBUS-DP)	827 562 9	827 563 7
SERVO operating mode	Recommended motor power → MCS4_A	
SERVO operating mode ($f_{PWM} = 8\ kHz$) Continuous output current = 100% I_N I_D	AC 80 A	AC 95 A
Recommended motor power	→ section SERVO motor selection	

MCH4_A standard version (VFC/CFC)	0220-203-4-00	0300-203-4-00
Part number MCH40A (without fieldbus)	827 624 2	827 625 0
Part number MCH41A (with PROFIBUS-DP)	827 670 6	827 671 4
Part number MCH42A (with INTERBUS-LWL)	827 595 5	827 596 3
MCH4_A application version (VFC/CFC)	0220-203-4-0T	0300-203-4-0T
Part number MCH40A (without fieldbus)	827 647 1	827 648 X
Part number MCH41A (with PROFIBUS-DP)	827 693 5	827 694 3
Part number MCH42A (with INTERBUS-LWL)	827 586 6	827 587 4
VFC operating mode	Recommended motor power → MCF4_A	
CFC/SERVO operating mode ($f_{PWM} = 8\ kHz$) Continuous output current = 100% I_N I_D	AC 80 A	AC 95 A
Recommended motor power	→ section CFC/SERVO motor selection	

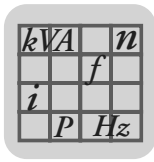

2.5 MOVIDRIVE® compact MCF/MCV/MCS electronics data

MOVIDRIVE® compact		Setpoint processing and speed ramps	
MCF/MCV/MCS40A and MCV/MCS41A		Version with analog setpoint input	
Voltage supply for setpoint input	X10:1 X10:3	REF1: DC+10 V +5 % / -0 %, $I_{\max} = \text{DC } 3 \text{ mA}$ REF2: DC-10 V +0 % / -5 %, $I_{\max} = \text{DC } 3 \text{ mA}$	Reference voltages for setpoint potentiometer
Setpoint input n1 (Differential input) Operating mode AI11/AI12 Resolution Internal resistance	X10:2/X10:4	AI11/AI12: Voltage or current input, can be set with S11 and P11_, sampling interval 1 ms Voltage input: n1 = DC (0...+10 V) or DC (-10 V...0...+10 V) 12 bit $R_i = 40 \text{ k}\Omega$ (external voltage supply) $R_i = 20 \text{ k}\Omega$ (supply from REF1/REF2)	Current input: n1 = DC (0...20 mA) or DC (4...20 mA) 11 bit $R_i = 250 \Omega$
MCF/MCV/MCS41A (X10:2 and X10:4 inactive for MCF41A)		Version with PROFIBUS-DP interface. No analog setpoint input n1 (AI11/AI12) available for MCF41A; setpoint selection only via PROFIBUS-DP interface.	
Protocol variant Baud rate Connection technology Bus terminator Station address Name of the GSD file DP ident. number		PROFIBUS DP to IEC 61158 Automatic baud rate detection from 9.6 kbaud to 12 Mbaud 9-pole sub D connector, pin assignment to IEC 61158 Can be activated for cable type A to IEC 61158 0 ... 125, adjustable via DIP switches SEW_6002.GSD 6002 _{hex} (24578 _{dec})	
Valid for all versions			
Setpoint input n2 TF/TH input Resolution	X10:6	Analog input DC (0 ... 10 V) or optionally (→ P120) TF/TH input with response threshold at $R_{TF} \geq 2.9 \text{ k}\Omega \pm 10 \%$ 10 bit	
Internal setpoints		Parameter set 1: n11/n12/n13 = -5000...0...+5000 min ⁻¹ Parameter set 2: n21/n22/n23 = -5000...0...+5000 min ⁻¹	
Time ranges of the speed ramps at $\Delta n = 3000 \text{ min}^{-1}$		1st ramp t11/t21 2nd ramp t12/t22 Stop ramp t13/t23 Emergency ramp t14/t24 Motor potentiometer t3	Up: 0.0...2000 s Down: 0.0...2000 s Up = down: 0.0...2000 s Down: 0...20 s Down: 0...20 s Up: 0.2...50 s Down: 0.2...50 s

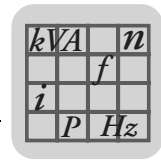

MOVIDRIVE® compact		Additional electronics data	
Auxiliary voltage output ¹⁾	X10:16	VO24: V _{OUT} = DC 24 V, maximum current carrying capacity I _{max} = DC 200 mA	
Ext. voltage supply ¹⁾	X10:24	VI24: V _{IN} = DC 24 V -15 % / +20 % according to EN 61131-2	
Binary inputs	X10:9...X10:14	DIØØ...DIØ5: Isolated (optocoupler), PLC-compatible (EN 61131), sampling interval 5 ms R _i ≈ 3 kΩ, I _E ≈ 10 mA	
Internal resistance			
Signal level		DC (+13 V...+30 V) = "1" = Contact closed DC (-3 V...+5 V) = "0" = Contact open	Complies with EN 61131
Function	X10:9 X10:10...X10:14	DIØØ: fixed assignment with "/Controller inhibit" DIØ1...DIØ5: Selection option → Parameter menu P60_	
Binary outputs ¹⁾	X10:21/X10:19	DBØØ/DOØ2: PLC-compatible (EN 61131-2), response time 5 ms	
Signal level		"0" = 0 V "1" = +24 V Important: Do not apply external voltage!	
Function	X10:21 X10:19	DBØØ: With fixed assignment "/Brake", I _{max} = DC 150 mA (short-circuit proof, protected against external voltage up to DC 30 V) DOØ2: Selection option → Parameter menu P62_, I _{max} = 50 mA (short-circuit proof and protected against external voltage up to DC 30 V)	
Only for MCF/MCV/MCS40A	X10:19	AOØ1: → Menu P64_, resolution 8 bit, I _{max} = DC 20 mA (short-circuit proof)	
Analog output			
Relay output	X10:18/20/22	DOØ1: Load capacity of the relay contacts V _{max} = DC 30 V, I _{max} = DC 800 mA	
Function	X10:18 X10:20 X10:22	DOØ1-C: Shared relay contact DOØ1-NO: Normally open contact DOØ1-NC: Normally closed contact	Selection option → parameter menu P62_
Systembus (SBus)	X10:5 X10:7	SC11: SBus high SC12: SBus low	CAN bus to CAN specification 2.0, parts A and B, transmission technology to ISO 11898, max. 64 stations, terminating resistor (120Ω) can be activated using DIP switch.
Input motor encoder ¹⁾	X15:	Incremental encoder for MCV4_A Permitted encoder types: • sin/cos encoder AC 1 V _{SS} • DC 5 V TTL sensor • DC 24 V HTL sensor Encoder power supply: DC+24 V, I _{max} = DC 180 mA	Resolver for MCS4_A 2-pole, AC 7 V _{eff} , 7 kHz
Not for MCF4_A			
Output for incremental encoder	X14:	Output for incremental encoder simulation: Signal level to RS422 Number of pulses as for X15: (MCV4_A) or fixed 1024 pulses/revolution (MCS4_A)	External encoder input (max. 200 kHz): Only connect encoders with signal level to RS422. Encoder power supply: DC+24 V, I _{max} = DC180 mA
simulation or external encoder input ¹⁾			
Not for MCF4_A			
Reference terminals	X10:8 X10:17/X10:23 X10:15	AGND: Reference potential for analog signals n1 and n2 and terminals X10:1 and X10:3. DGND: Reference potential for binary signals, system bus (SBus), encoder and resolver. DCOM: Reference potential for binary inputs X10:9...X10:14 (DIØØ...DIØ5).	
Permitted cable cross section		One core per terminal: 0.20...2.5 mm ² (AWG 24...12) Two cores per terminal: 0.20...1 mm ² (AWG 24...17)	

1) **MCF/MCV/MCS40A (without fieldbus):** The unit provides a current of I_{max} = DC 400 mA for the DC+24 V outputs (VO24, DBØØ, DOØ2, encoder supply). If this value is insufficient, a DC 24 V voltage supply must be connected to X10:24 (VI24). This external DC 24 V voltage supply must be able to provide 50 W continuous power and 100 W peak power (1 s).

MCF/MCV/MCS41A (with PROFIBUS-DP): SEW-EURODRIVE recommends that you always supply these units with DC 24 V at terminal X10:24 (VI24). This external DC 24 V voltage supply must be able to provide 50 W continuous power and 100 W peak power (1 s).
 The DC 24 V outputs X10:16 (VO24), X10:21 (DBØØ) and X10:19 (DOØ2) may be supplied with a total maximum current of I_{max} = DC 400 mA.

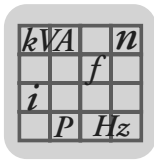

Front view of the MCF40A, MCF41A control unit

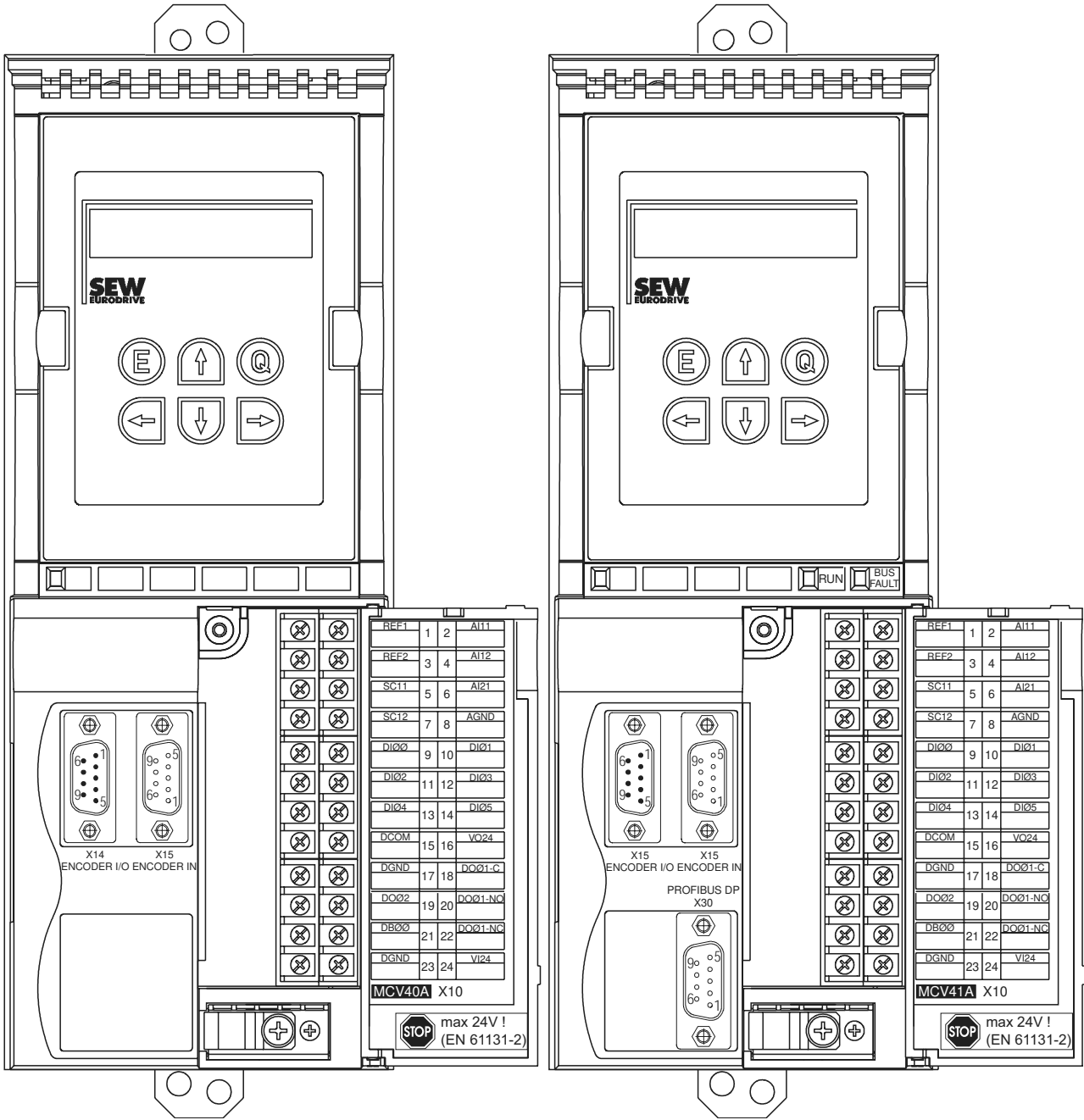
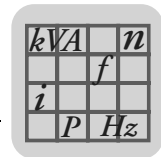
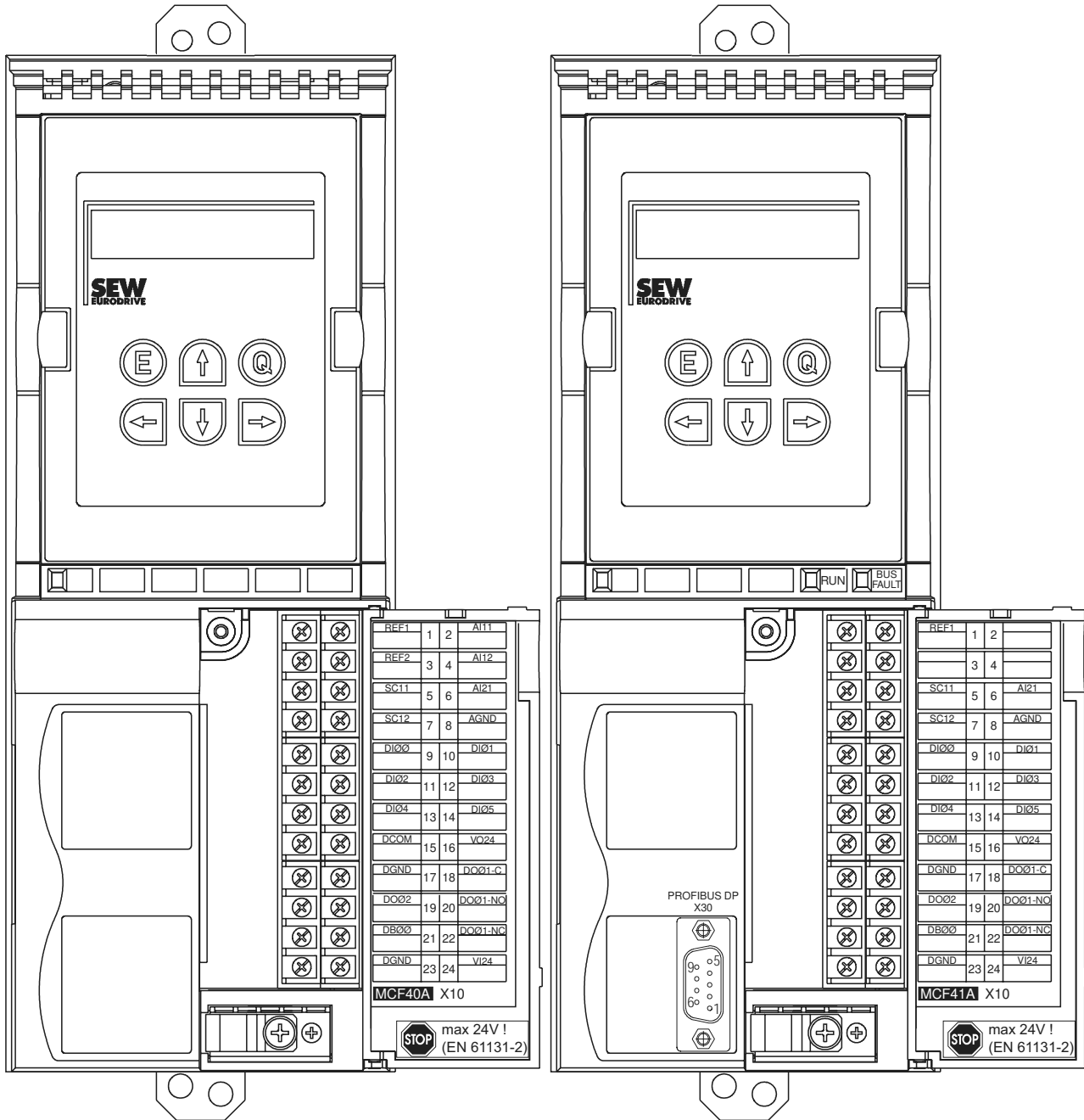

Figure 8: Front view of the MCF40A, MCF41A control unit

59894AXX



Front view of the MCV/MCS40A, MCV/MCS41A control unit



59898AXX

Figure 9: Front view of the MCV/MCS40A, MCV/MCS41A control unit

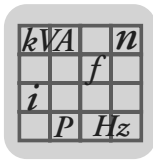
2.6 MOVIDRIVE® compact MCH electronics data

MOVIDRIVE® compact		Setpoint processing and speed ramps	
MCH40A		Version without fieldbus interface.	
MCH41A		Version with PROFIBUS-DP interface.	
Protocol variant Baud rate Connection technology Bus terminator Station address Name of the GSD file DP ident. number		PROFIBUS DP to IEC 61158 Automatic baud rate detection from 9.6 kbaud to 12 Mbaud 9-pole sub D connector, pin assignment to IEC 61158 Not integrated; connect using suitable PROFIBUS connector with terminating resistors that can be activated 0 ... 125, adjustable via DIP switches SEW_6003.GSD 6003 _{hex} (24579 _{dec})	
MCH42A		Version with INTERBUS fiber optic cable (LWL) interface.	
Protocol variant Baud rate Connection technology		INTERBUS to EN 61158-2 with optically controlled LWL interface 500 kBaud and 2 MBaud, can be selected via DIP switch 4 F-SMA connectors (2 × remote bus input and 2 × remote bus output)	
Valid for all versions			
Voltage supply for setpoint input	X10:1 X10:6	REF1: DC+10 V +5 % / -0 %, I _{max} = DC 3 mA REF2: DC-10 V +0 % / -5 %, I _{max} = DC 3 mA	Reference voltages for setpoint potentiometer
Setpoint input n1 (Differential input) Operating mode AI11/AI12 Resolution Internal resistance	X10:2/X10:3	AI11/AI12: Voltage or current input, can be set with S11 and P11_, sampling interval 1 ms Voltage input: n1 = DC (0...+10 V) or DC (-10 V...0...+10 V) 12 bit R _i = 40 kΩ (external voltage supply) R _i = 20 kΩ (supply from REF1/REF2)	Current input: n1 = DC (0...20 mA or 4...20 mA) 11 bit R _i = 250 Ω
Setpoint input n2 TF/TH input Resolution	X10:4	Analog input DC (0 ... 10 V) or optionally (→ P120) TF/TH input with response threshold at R _{TF} ≥ 2.9 kΩ ± 10 % 10 bit	
Internal setpoints		Parameter set 1: n11/n12/n13 = -5000...0...+5000 min ⁻¹ Parameter set 2: n21/n22/n23 = -5000...0...+5000 min ⁻¹	
Time ranges of the speed ramps at Δn = 3000 min ⁻¹		1st ramp t11/t21 Up: 0.0...2000 s Down: 0.0...2000 s 2nd ramp t12/t22 Up = down: 0.0...2000 s Stop ramp t13/t23 Down: 0...20 s Emergency ramp t14/t24 Down: 0...20 s Motor potentiometer t3 Up: 0.2...50 s Down: 0.2...50 s	

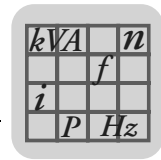

MOVIDRIVE® compact		Additional electronics data	
Auxiliary voltage output ¹⁾	X11:8	VO24: V _{OUT} = DC 24 V, maximum current carrying capacity I _{max} = DC 200 mA	
Ext. voltage supply ¹⁾ X12:6		VI24: V _{IN} = DC 24 V -15 % / +20 % to EN 61131-2	
Binary inputs Internal resistance	X11:1...X11:6	DIØØ...DIØ5: Isolated (optocoupler), PLC-compatible (EN 61131), sampling interval 5 ms R _i ≈ 3 kΩ, I _E ≈ 10 mA	
Signal level		DC (+13 V...+30 V) = "1" = Contact closed DC (-3 V...+5 V) = "0" = Contact open	Complies with EN 61131
Function	X11:1 X11:2...X11:6	DIØØ: fixed assignment with "/Controller inhibit" DIØ1...DIØ5: Selection option → parameter menu P60_	
Binary outputs ¹⁾	X12:1/X12:5	DBØØ/DOØ2: PLC-compatible (EN 61131-2), response time 5 ms	
Signal level		"0" = 0 V "1" = +24 V Important: Do not apply external voltage!	
Function	X12:1 X12:5	DBØØ: With fixed assignment "/Brake", I _{max} = DC 150 mA (short-circuit proof, protected against external voltage up to DC 30 V) DOØ2: Selection option → parameter menu P62_, I _{max} = DC 50 mA (short-circuit proof and protected against external voltage up to DC 30 V)	
Analog output	X12:5	AOØ1: → Menu P64_, resolution 8 bit, I _{max} = DC 20 mA (short-circuit proof)	
Relay output	X12:2/3/4	DOØ1: Load capacity of the relay contacts V _{max} = DC 30 V, I _{max} = DC 800 mA	
Function	X12:2 X12:3 X12:4	DOØ1-C: Shared relay contact DOØ1-NO: Normally open contact DOØ1-NC: Normally closed contact	Selection option → parameter menu P62_
System bus (SBus)	X10:7/10 X10:8/11	SC11/21: SBus high SC12/22: SBus low	CAN bus to CAN specification 2.0, parts A and B, transmission technology to ISO 11898, max. 64 stations, terminating resistor (120Ω) can be activated using DIP switch.
Input motor encoder ¹⁾	X15:	Permitted encoder types: <ul style="list-style-type: none"> • Hiperface encoder • sin/cos encoder AC 1 V_{SS} • TTL sensor Encoder power supply: DC + 12 V, I _{max} = DC 180 mA	
Output for incremental encoder simulation or external encoder input ¹⁾	X14:	Output for incremental encoder simulation: Signal level to RS422 The number of pulses is: <ul style="list-style-type: none"> • 1024 pulses/revolution (Hiperface® encoder on X15) • as at X15: Motor encoder input (sin/cos encoder or TTL sensor on X15) 	External encoder input (max. 200 kHz): Permitted encoder types: <ul style="list-style-type: none"> • Hiperface encoder • sin/cos encoder AC 1 V_{SS} • TTL sensor Encoder power supply: DC+12 V, I _{max} = DC 180 mA
Reference terminals	X10:5 X10:9/X11:9/X12:7 X11:7	AGND: Reference potential for analog signals n1 and n2 and terminals X10:1 and X10:6. DGND: Reference potential for binary signals, system bus (SBus), encoder and resolver. DCOM: Reference potential for binary inputs X10:9...X10:14 (DIØØ...DIØ5).	
Permitted line cross section		Only one core per terminal: 0.20...1.5 mm ² (AWG 24...16) Use right-angled crimping pliers with 1.5 mm ² (AWG 16)	

1) **MCH40A (without fieldbus):** The unit provides a current of I_{max} = DC 400 mA for the DC+24 V outputs (VO24, DBØØ, DOØ2, encoder supply). If this value is insufficient, a DC 24 V voltage supply must be connected to X10:24 (VI24). This external DC 24 V voltage supply must be able to provide 50 W continuous power and 100 W peak power (1 s).

MCH41A (with PROFIBUS-DP) or MCH42A (with INTERBUS-LWL): SEW-EURODRIVE recommends that you always supply these units with DC 24 V at terminal X10:24 (VI24). This external DC 24 V voltage supply must be able to provide 50 W continuous power and 100 W peak power (1 s).
The DC 24 V outputs X10:16 (VO24), X10:21 (DBØØ) and X10:19 (DOØ2) may be supplied with a total maximum current of I_{max} = DC 400 mA.

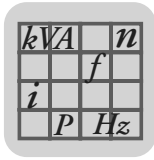

Front view of MCH42A control unit

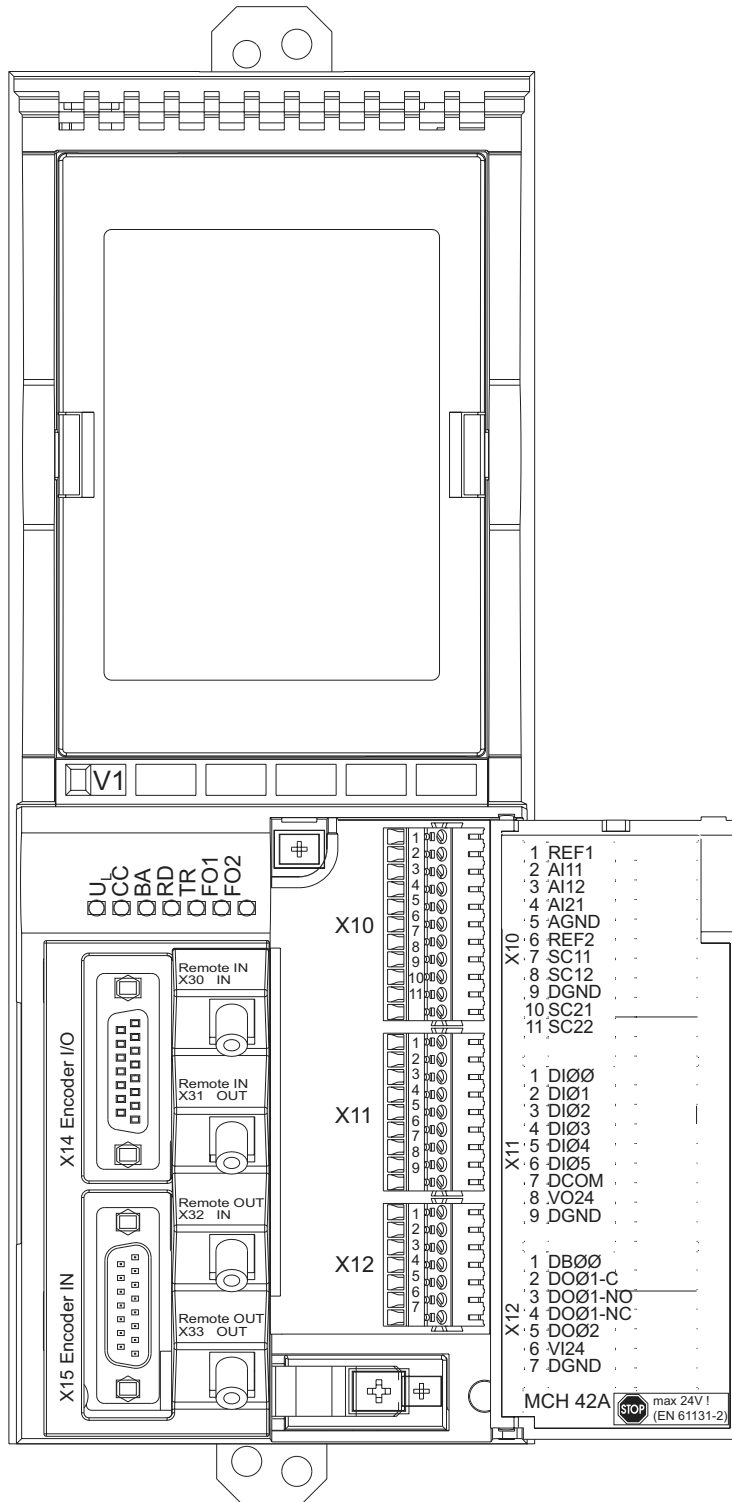
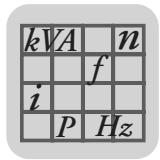

Figure 10: Front view of MCH42A control unit

59900AXX



2.7 MOVIDRIVE® compact dimension drawings

Dimension drawing for size 1 (0015 ... 0040-5A3 and 0015 ... 0037-2A3)

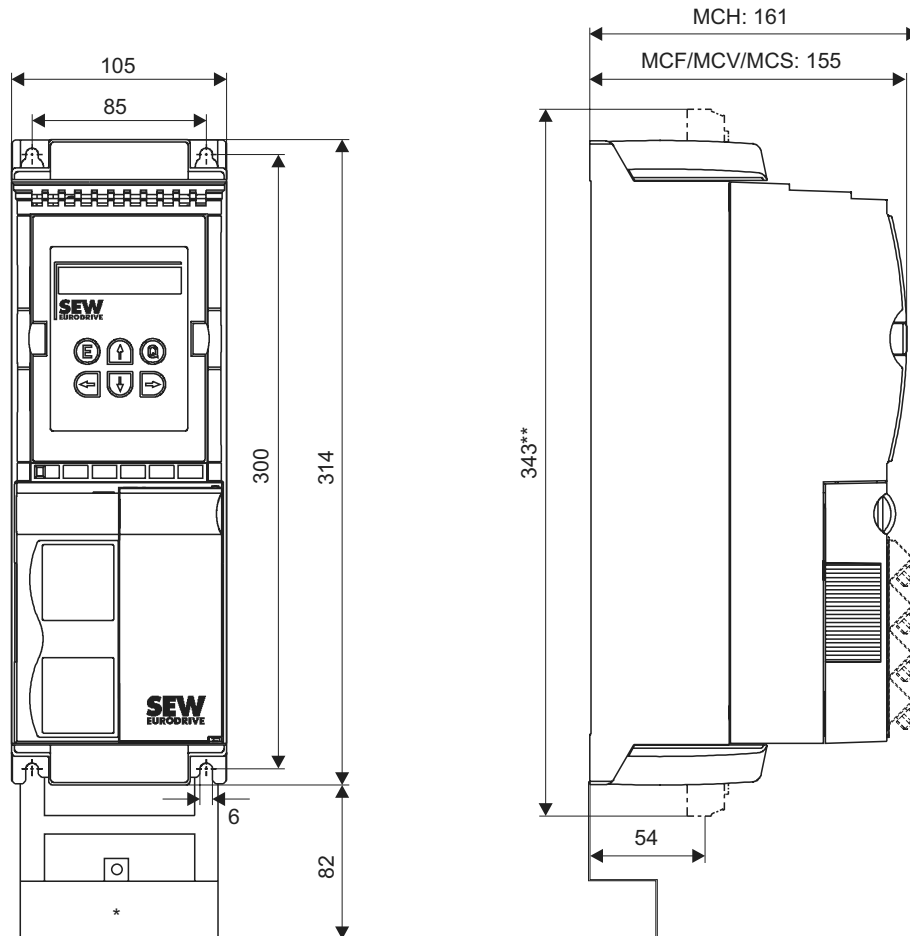

59816AXX

All dimensions in mm

* Power shield clamp

** Unit dimensions including connected power terminals



NOTE

Leave at least 100 mm clearance above and below the unit to ensure optimum cooling. There is no need for clearance at the sides. You can line up the units directly next to one another.

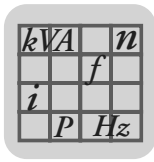

Dimension drawing for size 2 (0055 ... 0110-5A3 and 0055 / 0075-2A3)

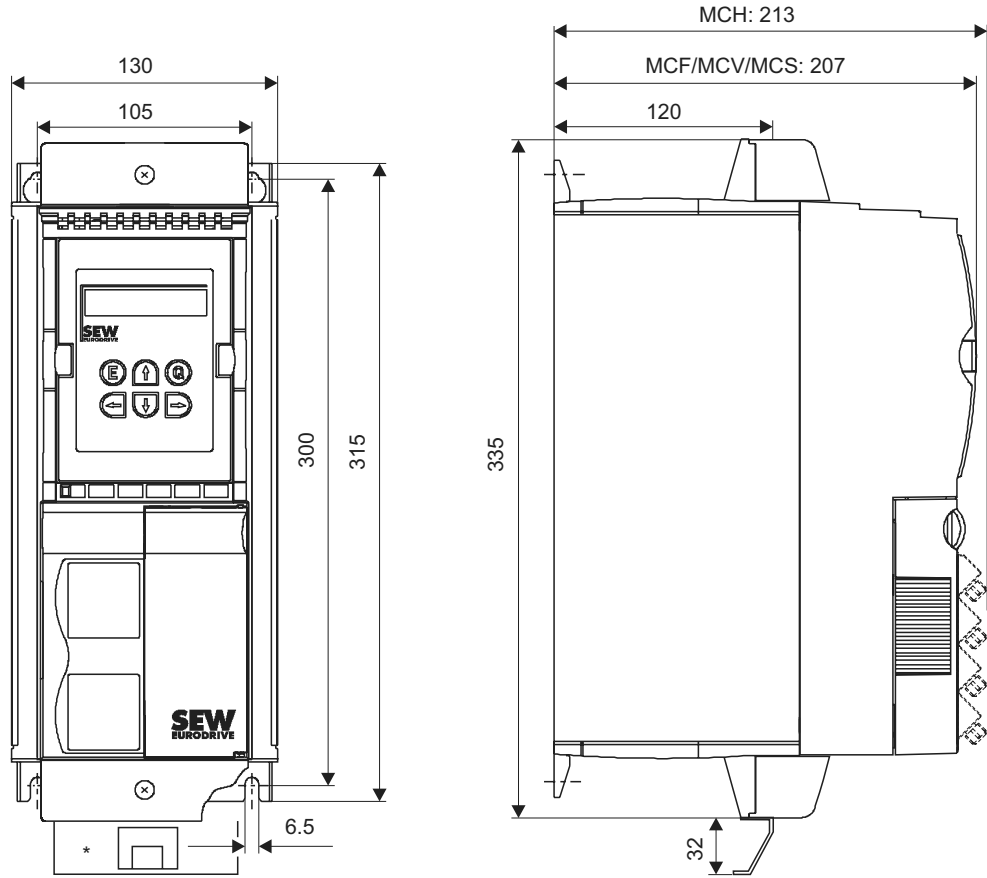

59817AXX

All dimensions in mm
 * Power shield clamp

	<p>NOTE</p> <p>Leave at least 100 mm clearance above and below the unit to ensure optimum cooling. There is no need for clearance at the sides. You can line up the units directly next to one another.</p>
--	--

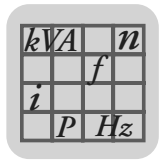

Dimension drawing for size 3 (0150 ... 0300-503 and 0110 / 0150-203)

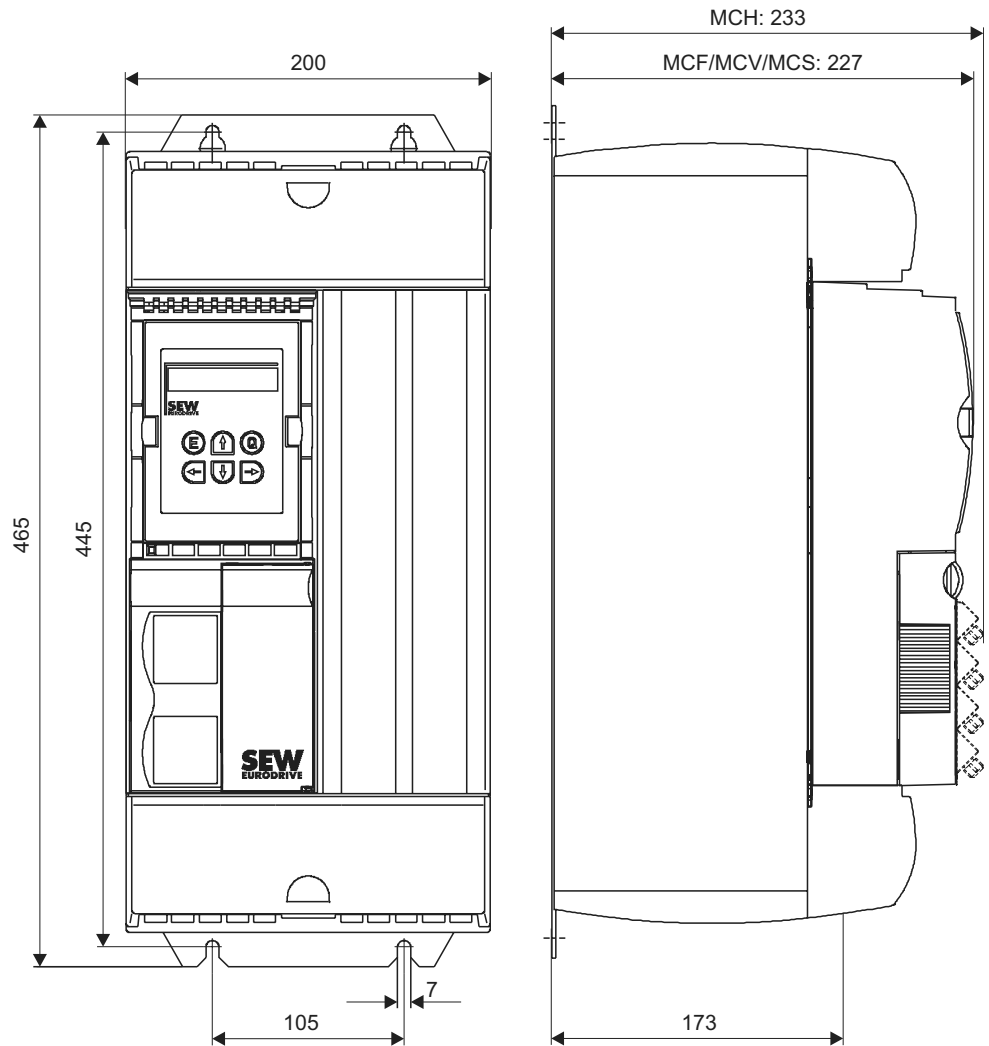

59818AXX

All dimensions in mm



NOTE

Leave at least 100 mm clearance above and below the unit to ensure optimum cooling. There is no need for clearance at the sides. You can line up the units directly next to one another.

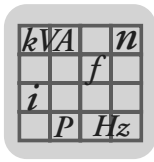

Dimension drawing for size 4 (0370 / 0450-503 and 0220 / 0300-203)

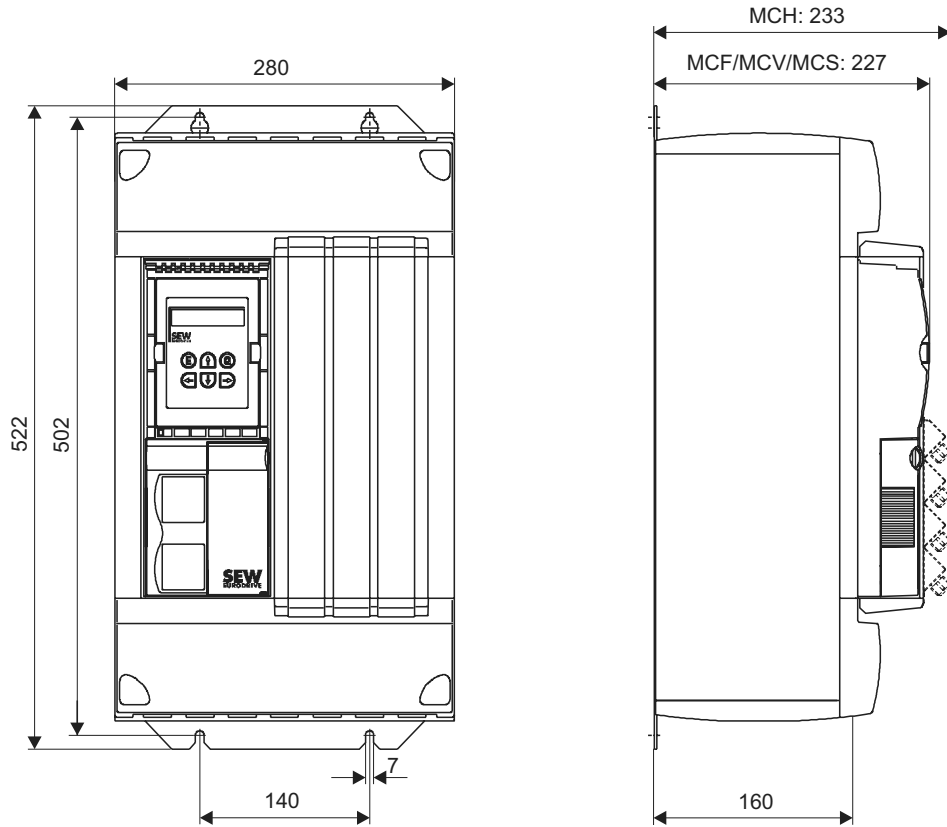

59819AXX

All dimensions in mm

NOTE



Leave at least 100 mm clearance above and below the unit to ensure optimum cooling. There is no need for clearance at the sides. You can line up the units directly next to one another.

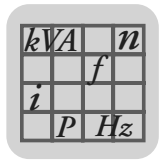

Dimension drawing for size 5 (0550 / 0750-503)

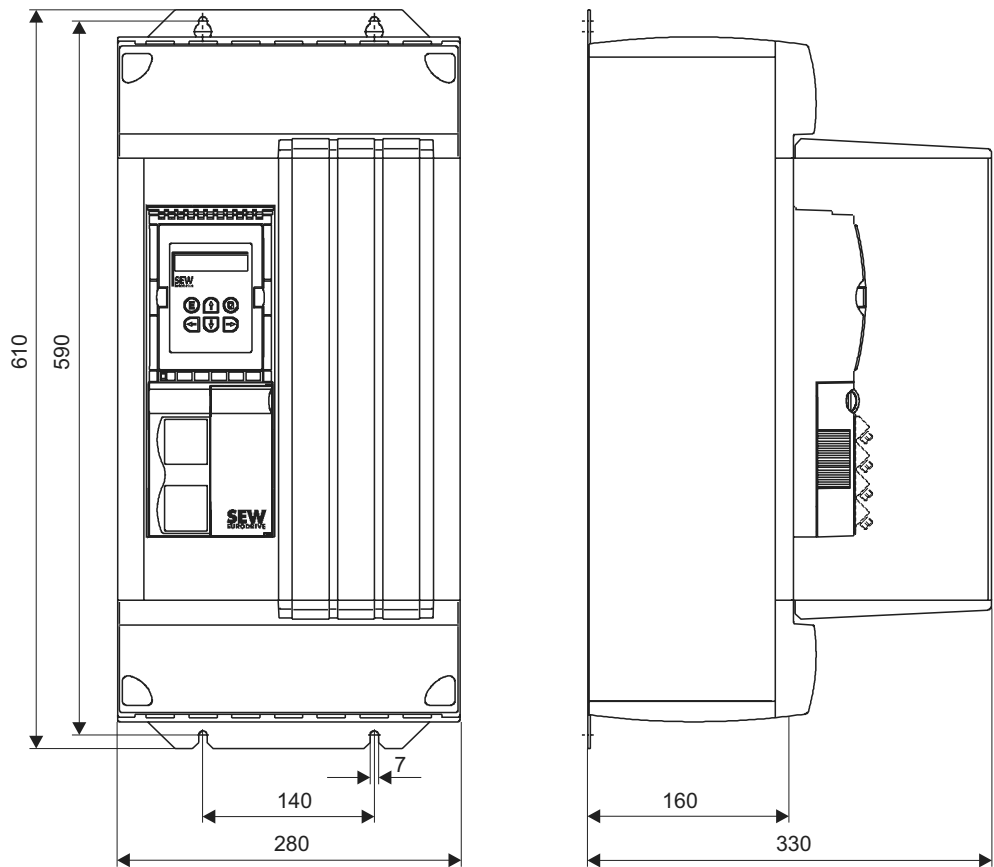

59820AXX

All dimensions in mm



NOTE

Provide at least 100 mm clearance above and below the unit. There is no need for clearance at the sides. You can line up the units directly next to one another.

Do not install any components that are sensitive to high temperatures within 300 mm of the top of the unit, for example contactors or fuses.

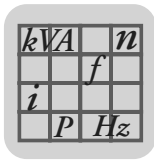

2.8 MOVIDRIVE® MDR60A regenerative power supply unit

In MOVIDRIVE® drive inverters operating in regenerative mode (4Q operation), the MOVIDRIVE® MDR60A regenerative power supply unit can be used as an alternative to braking resistors. The prerequisite is a powerful supply system. For more detailed information, refer to the "MOVIDRIVE® MDR60A Regenerative Power Supply Unit" system manual. This system manual can be ordered from SEW-EURODRIVE.

MOVIDRIVE® MDR60A supplies the DC link circuit of the connected MOVIDRIVE® drive inverter with electrical power from the supply system in motor operation and returns regenerative power to the supply system in regenerative operation.

UL approval



UL and cUL approval has been granted for the entire MOVIDRIVE® MDR60A0370-503-00 and MDR60A0750-503-00 range of units. cUL is equivalent to CSA approval. The MOVIDRIVE® MDR60A1320-503-00 unit does not have UL or cUL approval.

Protection and monitoring functions

- Monitoring and protection against thermal overload.
- Detection of power failure within one supply system half-wave.
- Overvoltage protection.



Figure 11: MOVIDRIVE® MDR60A regenerative power supply units

54512AXX

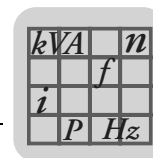

Features of the regenerative power supply unit compared to an inverter with braking resistors

- Energy balance: Regenerative power is fed back into the supply system instead of being converted into waste heat.
- Less installation work with several inverters (network and braking resistor connections). However, a braking resistor is required to bring the drive to a controlled stop even when there is a disruption in the supply system.
- Reduction in use of control cabinet space and fan power if the braking resistor was previously installed in the control cabinet.

General technical data

MOVIDRIVE® MDR60A	0370-503-00 (size 3) 0750-503-00 (size 4)	1320-503-00 (size 6)
Interference immunity	Complies with EN 61800-3	Meets EN 61000-6-1 and EN 61000-6-2
Interference emission with EMC-compliant installation	Complies with EN 61800-3 <ul style="list-style-type: none"> • With NF085-503 line filter (size 3) • With NF150-503 line filter (size 4) 	Meets EN 61000-6-4 with line filter NF300-503
Ambient temperature ϑ_U Derating ambient temperature	0 °C...+40 °C I_N reduction: 3 % I_N per K to max. 60 °C	0 °C...+40 °C I_N reduction: 3 % I_N per K to max. 55 °C
Climate class	EN 60721-3-3, class 3K3	
Storage temperature ¹⁾ ϑ_L	-25 °C...+70 °C (EN 60721-3-3, class 3K3)	-25 °C...+55 °C (EN 60721-3-3, class 3K3)
Cooling type (DIN 51751)	Forced cooling (temperature-controlled fan, response threshold 50 °C)	Forced cooling (temperature-controlled fan, response threshold 45 °C)
Enclosure EN 60529 (NEMA 1) Size 3 Size 4	IP20 IP00 (power connections) IP10 (power connections) <ul style="list-style-type: none"> • With fitted plexiglass cover supplied as standard • With shrink tubing (not included in scope of delivery) 	IP20
Operating mode	Continuous operation with 50 % overload capacity	
Overvoltage category	III according to IEC 60664-1 (VDE 0110-1)	
Pollution class	2 according to IEC 60664-1 (VDE 0110-1)	
Installation altitude	There are no restrictions for heights $\leq 1,000$ m. The following restrictions apply at heights $\geq 1,000$ m: <ul style="list-style-type: none"> • From 1,000 m to max. 4,000 m: <ul style="list-style-type: none"> - I_N reduction by 1% per 100 m (330 ft) • From 2,000 m to max. 4,000 m: <ul style="list-style-type: none"> - V_N reduction by AC 6 V per 100 m Over 2,000 m only overvoltage class 2; external measures are required for overvoltage class 3. Overvoltage classes according to DIN VDE 0110-1.	$h \leq 1,000$ m: No limitation From 1,000 m to max. 4,000 m: I_N reduction: 0.5 % per 100 m

1) In case of long-term storage, the unit must be connected to the mains voltage for at least 5 minutes every two years, otherwise the unit's service life may be reduced.

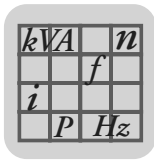

Technical data of the MOVIDRIVE® MDR60A regenerative power supply unit

MOVIDRIVE® MDR60A	0370-503-00 (size 3)	0750-503-00 (size 4)	1320-503-00 (size 6)
Part number	826 658 1	826 556 9	827 952 7
INPUT			
Supply voltage	V_{mains}	3 × AC 380 V –10 % ... 3 × AC 500 V +10 %	
Supply frequency	f_{mains}	50 Hz ... 60 Hz ±5 %	40 Hz ... 60 Hz ±10 %
Rated connected load	P_N	37 kW	AC 66 A
Rated supply current (at $V_{\text{mains}} = 3 \times \text{AC } 400 \text{ V}$)	I_{mains}	AC 66 A	AC 117 A
DC LINK			
Apparent output power (at $V_{\text{mains}} = 3 \times \text{AC } 380 \dots 500 \text{ V}$)	S_A	50 kVA	90 kVA
DC link voltage	V_{DClink}	DC 560 V ... 780 V	
Rated DC link current	I_{DClink}	DC 70 A	DC 141 A
Max. DC link current	$I_{\text{DC_max}}$	DC 105 A	DC 212 A
GENERAL INFORMATION			
Power loss at P_N	$P_{V_{\text{max}}}$	950 W	1,700 W
Cooling air consumption		180 m ³ /h	360 m ³ /h
Connection for power terminals X1, X2 (L1, L2, L3 for size 6) Permitted tightening torque Permitted cable cross section		M6 screw with washer 3.5 Nm 25 mm ² (AWG4)	M10 terminal studs 14 Nm 70 mm ² (AWG2/0) 3.5 Nm 25 mm ² (AWG4)
Connection for DC link connection ±UG Permitted cable cross section Permitted tightening torque		-	150 mm ² (power supply connection) / 30 Nm ¹ 185 mm ² (DC link connection) / 32 Nm ¹
Connection for electronics terminals X3 (X2 for size 6)		Permitted cable cross section: • One core per terminal: 0.20...2.5 mm ² (AWG24...13) • Two cores per terminal: 0.25...1 mm ² (AWG23...17)	Permitted cable cross section: • 0.8...4 mm ² (AWG18...12)
Weight		16 kg	24 kg
Dimensions	$W \times H \times D$	200 × 465 × 221 mm	280 × 522 × 205 mm
Line choke (always required)		ND085-013 $L_N = 0.1 \text{ mH}$ Part number 826 014 1	ND200-0033 $L_N = 0.03 \text{ mH}$ Part number 826 579 8
Line filter (optional)		NF085-503, part number 827 415 0	NF150-503, part number 827 417 7
For MOVIDRIVE® compact ...-5_3		0015 ... 0370	0015 ... 0750

1) Important: Do not apply tightening torque directly at terminals L1, L2, L3 and ±UG; use a second wrench.

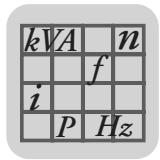

MDR60A dimension drawings

Provide at least 100 mm clearance above and below the unit. There is no need for clearance at the sides. You can line up the units directly next to one another. With sizes 4 and 6, do not install any components that are sensitive to high temperatures within 300 mm of the top of the unit, for example contactors or fuses.

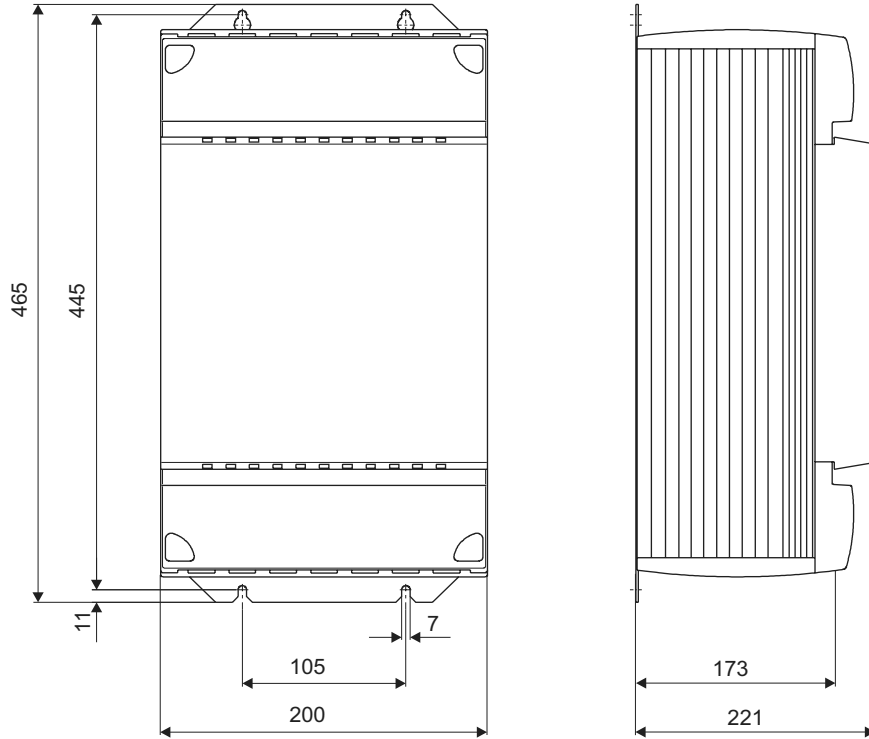

Figure 12: Dimension drawing for MDR60A size 3, dimensions in mm

54260BXX

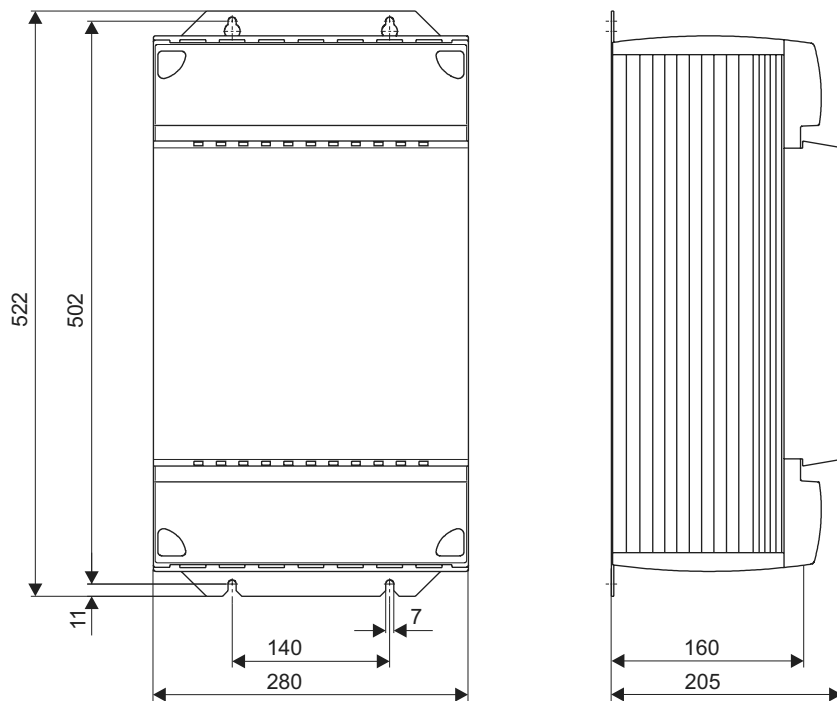
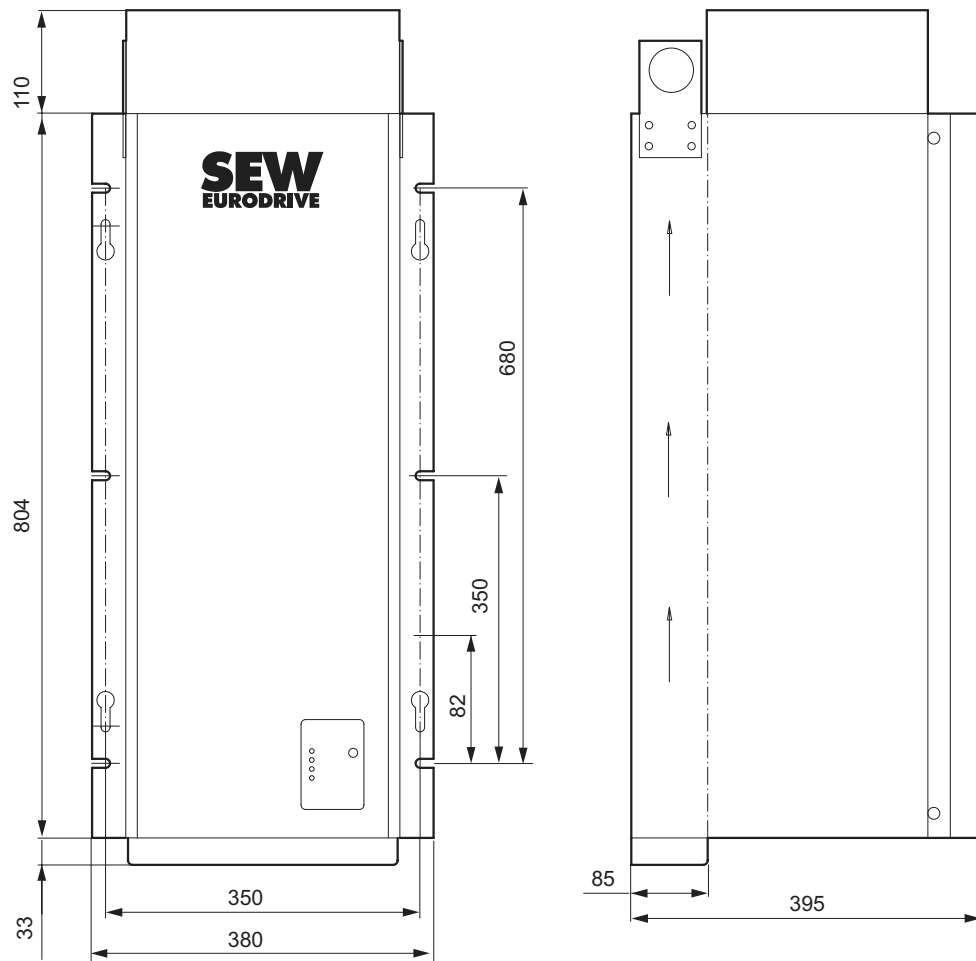
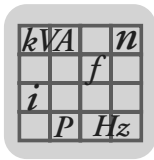

Figure 13: Dimension drawing for MDR60A size 4, dimensions in mm

54261BXX



54282BXX

Figure 14: Dimension drawing for MDR60A size 6, dimensions in mm

DC link connection

SEW-EURODRIVE recommends using the following cable sets for the DC link connection. These cable sets offer the appropriate dielectric strength and are also color-coded. Color coding is necessary because cross-polarity and ground faults could cause irreparable damage to the connected equipment.

The length of the cables restricts the DC link connection to the permitted length of 5 m. They can also be cut to length by the customer for connecting several units. The lugs for connection to the regenerative power supply unit and an inverter are supplied with the cable set. Use commercially available lugs for connecting additional inverters. The inverters must then be connected to the regenerative power supply unit in star configuration.

Cable set type	DCP12A	DCP13A	DCP15A
Part number	814 567 9	814 250 5	814 251 3
For connecting MOVIDRIVE®	0015 ... 0110	0150 ... 0370	0450 ... 0750



NOTE

Refer to the "MOVIDRIVE® MDR60A Regenerative Power Supply Unit" system manual for information on the DC link connection. This system manual can be ordered from SEW-EURODRIVE.

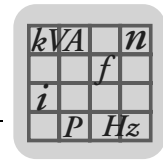

2.9 IPOSplus®

Description

IPOSplus® positioning and sequence control is integrated into every MOVIDRIVE® inverter as standard. IPOSplus® can be used to execute control functions and positioning tasks either simultaneously or independently of one another.

IPOSplus® sequence control makes it possible to run a user program, regardless of the encoder feedback or the selected control mode (VFC, CFC, SERVO). In conjunction with encoder feedback (MCV, MCS, MCH), IPOSplus® positioning provides high-performance point-to-point positioning. The IPOSplus® program is written using the MOVITOOLS® software. The operating software or DBG11B keypad (startup in VFC mode only) can be used to start up the inverter, access parameters and change variables.

Features

- Program execution independent of encoder feedback and operating mode.
- The user program is continued even if a unit malfunction occurs (troubleshooting is possible in the user program).
- Two user programs can be run in parallel and independently of one another (task 1, interrupt-capable, and task 2).
- The user programs programmed in the assembler can contain up to 800 program lines.
- User-friendly and comprehensive control options for the inverter.
- Extensive options for communication via system bus (SBus), RS-485, RS-232 and fieldbus (direct communication with MOVIMOT® is possible).
- Processing of digital and analog input/output signals.
- Positioning with adjustable travel speed and positioning ramps.
- Feedforward for position, speed and torque control loops with minimized lag error.
- Two touch probe inputs.
- Ramp types LINEAR, SINE and SQUARE.
- Status and monitoring functions: Lag error monitoring, position signal, software and hardware limit switches.
- Eight reference travel types.
- Possibility of changing the target position, travel speed, positioning ramp and torque when movement is in progress.
- Possibility of "endless positioning."
- Override function.

Only with
MCV/MCS/MCH

Technical data

Max. program length of tasks 1 and 2	In total about 800 program lines (programmed in assembler)
Command processing time per program line	Task 1: 1.0 ms; Task 2: 0.5 ms
Variables	512, of which 128 (0 ... 127) can be stored to non-volatile memory; range of values: $-2^{31} \dots + (2^{31}-1)$
Touch probe inputs	2 inputs, processing time < 100 µs
Sampling interval of digital and analog inputs	1...5 ms
Digital inputs/outputs	6 inputs / 3 outputs
Analog inputs/outputs	1 input (0...10 V, ±10 V, 0...20 mA, 4...20 mA) ¹⁾ 1 input (0...10 V) 1 output (0...20 mA, 4...20 mA)

1) Not for MCF41A

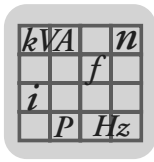

2.10 Optional DBG11B keypad

Description

The keypad is needed for startup and service. The basic version of MOVIDRIVE® does not have a keypad and can be upgraded to include the keypad as an option.

Keypad	Language	Part number
DBG11B-08	DE/EN/FR/ES/PT (German/English/French/Spanish/Portuguese)	824 154 6
DBG11B-09	EN/IT/SV/DA/FI (English/Italian/Swedish/Danish/Finnish)	824 155 4
DBG11B-11	ES/DE/EN/FR/PT (Spanish/German/English/French/Portuguese)	824 156 2
DBG11B-12	SV/EN/IT/DA/FI (Swedish/English/Italian/Danish/Finnish)	824 157 0
DBG11B-13	EN/ES/DE/FR/PT (English/Spanish/German/French/Portuguese)	824 158 9
DBG11B-14	FR/IT/ES/PT/EN (French/Italian/Spansih/Portuguese/English)	824 248 8
DBG11B-15	DE/EN/IT/ES/PT (German/English/Italian/Spanish/Portuguese)	824 423 5

Features

- Illuminated plain text display, five languages can be set.
- Membrane keypad with 6 keys.
- Choice of quick menu, detailed parameter menu and startup menu in VFC mode (CFC and SERVO startup is not possible with the DBG11B).
- Can be plugged onto the inverter (TERMINAL slot).
- Connection via extension cable FKG11A (part number 822 101 4) possible.
- Enclosure IP40 (EN 60529)

Note

The DBG11B keypad option and the USS21A/USB11A serial interface options are plugged into the same inverter slot (TERMINAL) and therefore cannot be used at the same time.

Functions

- Display process values and status.
- Status of binary inputs and outputs.
- Query error memory and error reset.
- Option to display and set the operating parameters and service parameters.
- Data backup and transfer of parameter sets to other MOVIDRIVE® units.
- User-friendly startup menu for VFC mode.
- Option to save a curve with electronic cam.

Dimension drawing for DBG11B and FKG11A

All dimensions in mm.

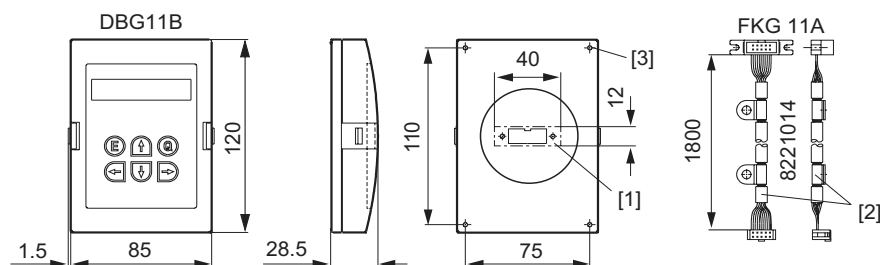

59821AXX

- [1] Cut-out for connector in mounting panel
- [2] Communication cable for DBG11B - MOVIDRIVE®
- [3] Holes for tapping screws 3.5 × 9.5 mm

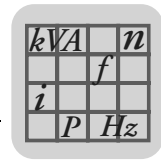

2.11 Serial interface option type USS21A (RS232 and RS485)

Part number 822 914 7

Description MOVIDRIVE® can be equipped with isolated interfaces RS232 and RS485. The RS232 interface is designed as a 9-pole sub-D socket (EIA standard) and the RS485 interface as a terminal connection. The interfaces are accommodated in a housing to be plugged into the inverter (TERMINAL option slot). The option can be plugged in during operation. The transmission rate of both interfaces is 9,600 Baud.

Startup, operation and service can be performed from the PC via the serial interface. Use the SEW software MOVITOOLS® for this purpose. Set parameters can also be transferred to several MOVIDRIVE® drive inverters via the PC.

Note The DBG11B, USS21A and USB11A options are plugged into the same inverter slot (TERMINAL) and therefore cannot be used at the same time.

RS232 interface To connect a PC to the MOVIDRIVE® option USS21A, use a commercially available, serial, shielded interface cable with a 1:1 connection assignment.

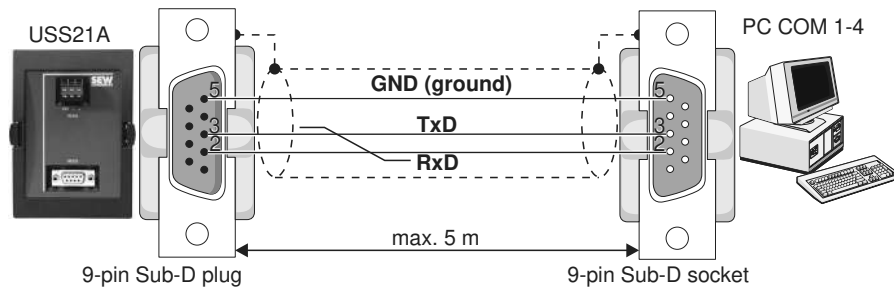

59829AEN

Figure 15: USS21A - PC connection cable (1:1 connection assignment)

RS485 interface

A maximum of 16 MOVIDRIVE® units can be connected for communication (max. cable length 200 m) via the RS485 interface of the USS21A. Do not connect external terminating resistors as dynamic terminating resistors are already installed!

The unit addresses 0...99 are permitted for multipoint connections. In this case, do not select the point-to-point connection option in MOVITOOLS®. The communication address in MOVITOOLS® must match the RS485 address of MOVIDRIVE® (P810).

Dimension drawing for USS21A

All dimensions in mm.

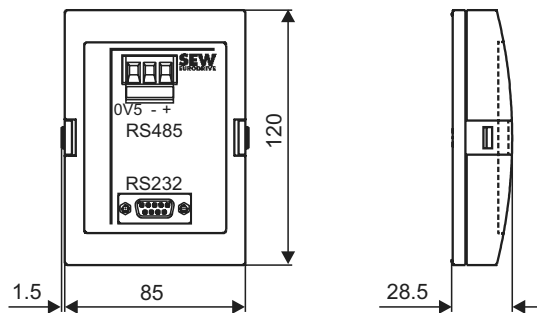

59822AXX

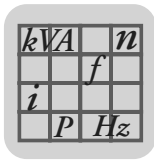

2.12 Interface adapter type USB11A / option DKG11A

- Part number**
- 824 831 1 Interface adapter USB11A
 - 819 558 7 Serial interface cable DKG11A

Description Option USB11A enables a PC or laptop with a USB interface to be connected to the TERMINAL slot of MOVIDRIVE[®] compact. The USB11A interface adapter supports USB1.1 and USB2.0.

- Scope of delivery**
- The scope of delivery for the USB11A includes:
 - USB11A interface adapter
 - USB connection cable PC - USB11A (type USB A-B)
 - CD-ROM with drivers and MOVITOOLS[®]
 - The USB11A interface adapter supports USB 1.1 and USB 2.0.
 - The scope of delivery for the USB11A **does not** include:
 - DKG11A connection cable (length 3 m, part number 819 558 7) for connecting MOVIDRIVE[®] compact - USB11A.

Connecting MOVIDRIVE[®] - USB11A - PC

- MOVIDRIVE[®] compact is connected to USB11A (cable RJ10-TERMINAL) using the serial interface cable type DKG11A (length 3 m, part number 819 558 7).
- USB11A is connected to the PC using a commercially available, shielded USB connection cable type USB A-B.

Dimension drawing

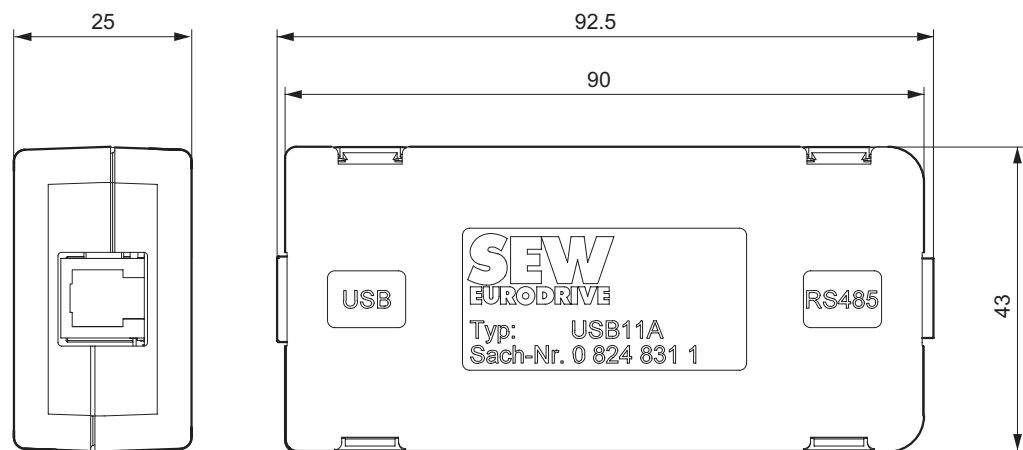

55732BXX

Figure 16: USB11A dimension drawing, dimensions in mm

Technical data

USB11A	
Part number	824 831 1
Ambient temperature	0 °C... 40 °C
Storage temperature	-25 °C ... +70 °C (according to EN 60721-3-3, class 3K3)
Enclosure	IP20
Weight	300 g
Dimensions	92.5 x 43 x 25 mm

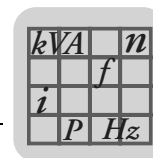

2.13 DC 5 V encoder supply type DWI11A

Part number 822 759 4

Description

If you are using an incremental encoder with a DC 5 V encoder power supply, install the DC 5 V encoder power supply option type DWI11A between the inverter and the incremental encoder. This option provides a regulated DC 5 V power supply for the encoder. For this purpose, the DC 12 V power supply for the encoder inputs is converted to DC 5 V by means of a voltage controller. A sensor line is used to measure the supply voltage at the encoder and compensate the voltage drop along the encoder cable.

Incremental encoders with DC 5 V encoder power supply may not be connected directly to the encoder inputs X14: and X15:.. This would cause irreparable damage to the encoder.

	NOTE
	If a short circuit occurs in the sensor cable, the connected encoder may be exposed to a voltage higher than permitted.

Recommendation Use prefabricated cables from SEW for the encoder connection.

Dimension drawing

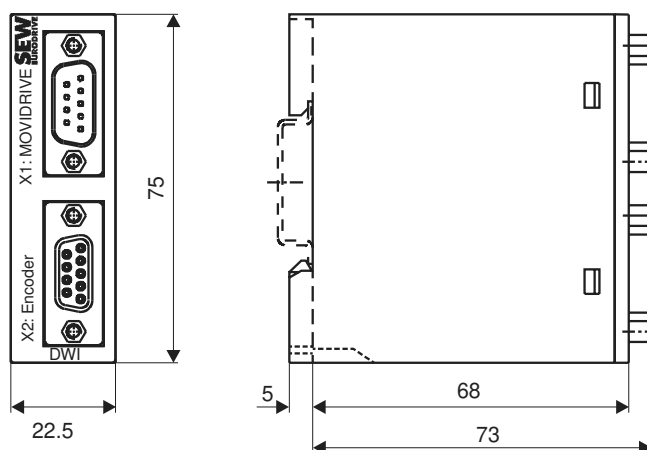

Figure 17: DWI11A dimension drawing, dimensions in mm

01315CXX

The DWI11A option is mounted on a support rail (EN 50022-35 × 7.5) in the control cabinet.

Technical data

DC 5 V encoder power supply option type DWI11A	
Part number	822 759 4
Voltage input	DC 10...30 V, $I_{max} = DC 120\text{ mA}$
Encoder power supply	DC +5 V (up to $V_{max} \approx +10\text{ V}$), $I_{max} = DC 300\text{ mA}$
Max. line length that can be connected	100 m total Use a shielded twisted-pair cable (A and \bar{A} , B and \bar{B} , C and \bar{C}) for connecting the encoder to the DWI11A and the DWI11A to MOVIDRIVE®.

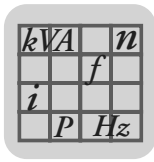

2.14 Braking resistors type BW... / BW...-T / BW...-P

General information

- Braking resistors BW... / BW...-T and BW...-P are adapted to the technical characteristics of MOVIDRIVE® drive inverters.
- Plan for a reduction of power of 4 % per 10 K below an ambient temperature of 45 °C. Do not exceed a maximum ambient temperature of 80 °C.

Flat-type braking resistors

- Protection against contact (IP54)
- Internal thermal overload protection (non-replaceable fuse)
- Touch guard and mounting rail attachment available from SEW as accessories

Wire and grid resistors

- Perforated sheet cover (IP20) open to mounting surface
- The short-term load capacity of the wire and grid resistors is higher than in the flat-type braking resistors (→ MOVIDRIVE® compact system manual, section "Selecting the braking resistor")
- A temperature switch is integrated in the BW...-T braking resistor
- A thermal overcurrent relay is integrated in the BW...-P braking resistor

SEW-EURODRIVE recommends implementing additional protection against overload for the wire and grid resistors by using a bimetallic relay with trip characteristics of trip class 10 or 10A (in accordance with EN 60947-4-1). Set the trip current to the value I_F (→ following tables). Do not use electronic or electromagnetic fuses because these can be triggered even in case of short-term excess currents that are still within the tolerance range.

For braking resistors in the BW...-T / BW...-P series, you can connect the integrated temperature sensor using a 2-core, shielded cable as an alternative to a bimetallic relay. The BW...-T and BW...-P braking resistors can be connected from the front or the back (→ dimension drawing for BW... / BW...-T / BW...-P braking resistors). Use filler plugs for tapped holes that are not connected.

The resistor surfaces will get very hot under a load of P_N . Make sure that you select an installation site that will accommodate these high temperatures. Braking resistors are usually mounted on the control cabinet roof.

The performance data listed in the tables below shows the load capacity of the braking resistors according to their cyclic duration factor (cyclic duration factor = cdf of the braking resistor in % in relation to a cycle duration ≤ 120 s).

UL and cUL approval

Type BW... braking resistors are UL and cUL approved in conjunction with MOVIDRIVE® compact drive inverters. SEW-EURODRIVE can provide proof of approval on request. The BW...-T and BW...-P braking resistors have cRUus approval independent of the MOVIDRIVE® inverters.

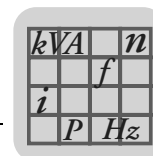

Parallel connection

Two braking resistors with the same value must be connected in parallel for some inverter/resistor combinations. In this case, the trip current must be set on the bimetallic relay to twice the value of I_F entered in the table. For the BW...-T / BW...-P braking resistors, the temperature switch / overcurrent relay must be connected in series.

Assignment to AC 400/500 V units (...-5_3)

Braking resistor type BW...	BW100-005	BW100-006	BW168	BW268
Part number	826 269 1	821 701 7	820 604 X	820 715 1
Braking resistor type BW...-T		BW100-006-T	BW168-T	BW268-T
Part number		1 820 419 8	1 820 133 4	1 820 417 1
Cont. braking power (= 100 % cdf)	0.45 kW	0.6 kW	0.8 kW	1.2 kW
Load capacity 50 % cdf ¹⁾	0.60 kW	1.1 kW	1.4 kW	2.2 kW
at 25 % cdf	0.83 kW	1.9 kW	2.6 kW	3.8 kW
12 % cdf	1.11 kW	3.6 kW	4.8 kW	7.2 kW
6 % cdf	2.00 kW	5.7 kW	7.6 kW	11 kW
Observe the regenerative power limit of the inverter! (= 150 % of the recommended motor power → Technical Data)				
Resistance value R_{BW}	100 Ω \pm 10 %		68 Ω \pm 10 %	
Trip current (of F16) I_F	0.8 A _{RMS}	2.4 A _{RMS}	3.4 A _{RMS}	4.2 A _{RMS}
Design	Flat design	Wire resistor on ceramic core	Wire resistor on ceramic core	
Connections/ tightening torque	Cable	Ceramic terminals 2.5 mm ² (AWG13) 0.5 Nm	Ceramic terminals 2.5 mm ² (AWG13) 0.5 Nm	
Enclosure	IP54	IP20 (when installed)	IP20 (when installed)	
Ambient temperature ϑ_U	-20 °C ... +40 °C			
Type of cooling	KS = self-cooling			
For MOVIDRIVE®	0015 ... 0022	0015 ... 0040	0015 ... 0040	0015 ... 0040

1) cdf = cyclic duration factor of the braking resistor based on a cycle duration $T_D \leq 120$ s.

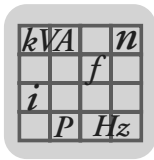

Technical Data and Dimension Drawings

Braking resistors type BW... / BW...-T / BW...-P

Braking resistor type BW...	BW147	BW247	BW347	BW039-012		
Part number	820 713 5	820 714 3	820 798 4	821 689 4		
Braking resistor type BW...-T	BW147-T	BW247-T	BW347-T	BW039-012-T	BW039-026-T	BW039-050-T
Part number	1 820 134 2	1 820 084 2	1 820 135 0	1 820 136 9	1 820 415 5	1 820 137 7
Cont. braking power (= 100 % cdf)	1.2 kW	2.0 kW	4.0 kW	1.2 kW	2.6 kW	5.0 kW
Load capacity at 50 % cdf ¹⁾	2.2 kW	3.6 kW	7.2 kW	2.1 kW	4.7 kW	8.5 kW
at 25 % cdf	3.8 kW	6.4 kW	12.8 kW	3.8 kW	8.3 kW	15.0 kW
12 % cdf	7.2 kW	12 kW	20 kW ²⁾	7.2 kW	15.6 kW	24.0 kW ²⁾
6 % cdf	11 kW	19 kW	20 kW ²⁾	11.4 kW	24.0 kW ²⁾	24.0 kW ²⁾
Observe the regenerative power limit of the inverter! (= 150 % of the recommended motor power → Technical Data)						
Resistance value R_{BW}	47 Ω \pm 10 %			39 Ω \pm 10 %		
Trip current (of F16) I_F	5 A _{RMS}	6.5 A _{RMS}	9.2 A _{RMS}	5.5 A _{RMS}	8.1 A _{RMS}	11.3 A _{RMS}
Design	Wire resistor on ceramic core					Grid resistor
Connections/ tightening torque	Ceramic terminals 2.5 mm ² (AWG13) / 0.5 Nm BW347-T: Ceramic terminals 10 mm ² (AWG8) / 1.6 Nm					M8 stud / 6 Nm
Enclosure	IP20 (when installed)					
Ambient temperature ϑ_U	-20 °C ... +40 °C					
Type of cooling	KS = self-cooling					
For MOVIDRIVE®	0055/0075			0110		

- 1) cdf = cyclic duration factor of the braking resistor based on a cycle duration $T_D \leq 120$ s.
- 2) Physical power limit due to DC link voltage and resistance value.

Braking resistor type BW...	BW018-015			
Part number	821 684 3			
Braking resistor type BW...-T/-P	BW018-015-P	BW018-035-T	BW018-075-T	BW915-T
Part number	1 820 416 3	1 820 138 5	1 820 139 3	1 820 413 9
Cont. braking power (= 100 % cdf)	1.5 kW	3.5 kW	7.5 kW	16 kW
Load capacity at 50 % cdf ¹⁾	2.5 kW	5.9 kW	12.7 kW	27.2 kW
at 25 % cdf	4.5 kW	10.5 kW	22.5 kW	48 kW
12 % cdf	6.7 kW	15.7 kW	33.7 kW	62.7 kW ²⁾
6 % cdf	11.4 kW	26.6 kW	52.2 kW ²⁾	62.7 kW ²⁾
Observe the regenerative power limit of the inverter! (= 150 % of the recommended motor power → Technical Data)				
Resistance value R_{BW}	18 Ω \pm 10 %			15 Ω \pm 10 %
Trip current (of F16) I_F	9.1 A _{RMS}	13.9 A _{RMS}	20.4 A _{RMS}	32.6 A _{RMS}
Design	Wire resistor on ceramic core	Steel-grid resistor		
Connections/ tightening torque	BW018-015: Ceramic terminals 2.5 mm ² (AWG13) / 0.5 Nm BW018-015-P: Terminal 2.5 mm ² (AWG13) / 1 Nm	M8 bolt / 6 Nm		
Enclosure	IP20 (when installed)			
Ambient temperature ϑ_U	-20 °C ... +40 °C			
Type of cooling	KS = self-cooling			
For MOVIDRIVE®	0150/0220 and 2 × parallel for 0370/0450 ³⁾			0220

- 1) cdf = cyclic duration factor of the braking resistor based on a cycle duration $T_D \leq 120$ s.
- 2) Physical power limit due to DC link voltage and resistance value.
- 3) When connected in parallel, the load capacity and trip current are doubled.

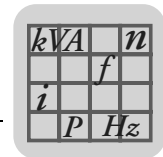

Braking resistor type BW...-	BW012-025				
Part number	821 680 0				
Braking resistor type BW...-T/-P	BW012-025-P	BW012-050T	BW012-100-T	BW106-T	BW206-T
Part number	1 820 414 7	1 820 140 7	1 820 141 5	1 820 083 4	1 820 412 0
Cont. braking power (= 100 % cdf)	2.5 kW	5.0 kW	10 kW	13.5 kW	18 kW
Load capacity	4.2 kW	8.5 kW	17 kW	23 kW	30.6 kW
at					
25 % cdf	7.5 kW	15.0 kW	30 kW	40 kW	54 kW
12 % cdf	11.2 kW	22.5 kW	45 kW	61 kW	81 kW
6 % cdf	19.0 kW	38.0 kW	76 kW	102 kW	136.8 kW
Observe the regenerative power limit of the inverter! (= 150 % of the recommended motor power → Technical Data)					
Resistance value R_{BW}	12 Ω \pm 10 %			6 Ω \pm 10 %	
Trip current (of F16) I_F	14.4 A _{RMS}	20.4 A _{RMS}	28.8 A _{RMS}	47.4 A _{RMS}	54.7 A _{RMS}
Design	Steel-grid resistor				
Connections/ tightening torque	Ceramic terminals 2.5 mm ² (AWG13) / 0.5 Nm BW012-025-P: Terminals 4 mm ² (AWG12) / 1 Nm			M8 bolt / 6 Nm	
Enclosure	IP20 (when installed)				
Ambient temperature ϑ_U	-20 °C ... +40 °C				
Type of cooling	KS = self-cooling				
For MOVIDRIVE®	0300			0370...0750	

1) cdf = cyclic duration factor of the braking resistor based on a cycle duration $T_D \leq 120$ s.

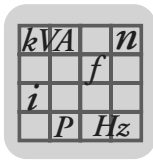

Assignment to AC 230 V units (...-2_3)

Braking resistor type BW...	BW039-003	BW039-006	BW039-012		BW027-006	BW027-012		
Part number	821 687 8	821 688 6	821 689 4		822 422 6	822 423 4		
Braking resistor type BW...T/...P			BW039-012-T	BW039-026-T			BW018-015-P	BW018-035-T
Part number			1 820 136 9	1 820 415 5			1 820 416 3	1 820 138 5
Cont. braking power (= 100 % cdf)	0.3 kW	0.6 kW	1.2 kW	2.6 kW	0.6 kW	1.2 kW	1.5 kW	3.5 kW
Load capacity at 50 % cdf ¹⁾	0.5 kW	1.1 kW	2.1 kW	4.6 kW	1.1 kW	2.1 kW	2.5 kW	5.9 kW
at 25 % cdf	1.0 kW	1.9 kW	3.8 kW	6.0 kW ²⁾	1.9 kW	3.8 kW	4.5 kW	10.5 kW
12 % cdf	1.8 kW	3.6 kW	6.0 kW ²⁾	6.0 kW ²⁾	3.6 kW	7.2 kW	6.7 kW	13.0 kW ²⁾
6 % cdf	2.8 kW	5.7 kW	6.0 kW ²⁾	6.0 kW ²⁾	5.7 kW	8.7 kW ²⁾	11.4 kW	13.0 kW ²⁾
Observe the regenerative power limit of the inverter! (= 150 % of the recommended motor power → Technical Data)								
Resistance value R_{BW}	39 Ω \pm 10 %				27 Ω \pm 10 %		18 Ω \pm 10 %	
Trip current (of F16) I_F	2.7 A _{RMS}	3.9 A _{RMS}	5.5 A _{RMS}	8.1 A _{RMS}	4.7 A _{RMS}	6.6 A _{RMS}	9.1 A _{RMS}	13.9 A _{RMS}
Design	Wire resistor						Steel-grid resistor	
Connections/tightening torque	Ceramic terminals 2.5 mm ² (AWG12) / 0.5 Nm						M8 stud / 6 Nm	
Enclosure	IP20 (when installed)							
Ambient temperature ϑ_U	-20 °C ... +40 °C							
Type of cooling	KS = self-cooling							
For MOVIDRIVE®	0015/0022				0015...0037		2 × parallel with 0110 ³⁾	

- 1) cdf = cyclic duration factor of the braking resistor based on a cycle duration $T_D \leq 120$ s.
- 2) Physical power limit due to DC link voltage and resistance value.
- 3) When connected in parallel, the load capacity and trip current are doubled.

Braking resistor type BW...T	BW018-075-T	BW915-T	BW012-025-T	BW012-050-T	BW012-100-T	BW106-T	BW206-T
Part number	1 820 139 3	1 820 413 9	1 820 414 7	1 820 140 7	1 820141 5	1 820 083 4	1 820 4120
Cont. braking power (= 100 % cdf)	7.5 kW	15.6 kW ²⁾	2.5 kW	5.0 kW	10 kW	13.5 kW	18 kW
Load capacity at 50 % cdf ¹⁾	12.7 kW	15.6 kW ²⁾	4.2 kW	8.5 kW	17 kW	23 kW	30.6 kW
at 25 % cdf	13.0 kW ²⁾	15.6 kW ²⁾	7.5 kW	15.0 kW	19.6 kW ²⁾	39.2 kW ²⁾	39.2 kW ²⁾
12 % cdf	13.0 kW ²⁾	15.6 kW ²⁾	11.2 kW	19.6 kW ²⁾	19.6 kW ²⁾	39.2 kW ²⁾	39.2 kW ²⁾
6 % cdf	13.0 kW ²⁾	15.6 kW ²⁾	19.0 kW	19.6 kW ²⁾	19.6 kW ²⁾	39.2 kW ²⁾	39.2 kW ²⁾
Observe the regenerative power limit of the inverter! (= 150 % of the recommended motor power → Technical Data)							
Resistance value R_{BW}	18 Ω \pm 10 %	15 Ω \pm 10 %	12 Ω \pm 10 %			6 Ω \pm 10 %	
Trip current (of F16) I_F	20.4 A _{RMS}	32.6 A _{RMS}	14.4 A _{RMS}	20.4 A _{RMS}	28.8 A _{RMS}	47.4 A _{RMS}	54.7 A _{RMS}
Design	Steel-grid resistor						
Connections/tightening torque	M8 stud / 6 Nm						
Enclosure	IP20 (when installed)						
Ambient temperature ϑ_U	-20 °C ... +40 °C						
Type of cooling	KS = self-cooling						
For MOVIDRIVE®	2 × parallel with 0110 ³⁾		0055/0075			0150 and 2 × parallel with 0220/0300 ³⁾	

- 1) cdf = cyclic duration factor of the braking resistor based on a cycle duration $T_D \leq 120$ s.
- 2) Physical power limit due to DC link voltage and resistance value.
- 3) When connected in parallel, the load capacity and trip current are doubled.

Technical data for braking resistors BW...-T / BW...-P

BW...-T / BW...-P	
Connection cross section for signal contact	1 x 2.5 mm ²
Switching capability of the thermostat's signal contact	<ul style="list-style-type: none"> • DC 2 A / DC 24 V (DC11) • AC 2 A / AC 230V (AC11)
Switch contact (NC)	according to EN 61800-5-1

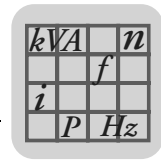

Dimension drawings for braking resistors BW... / BW...-T / BW...-P

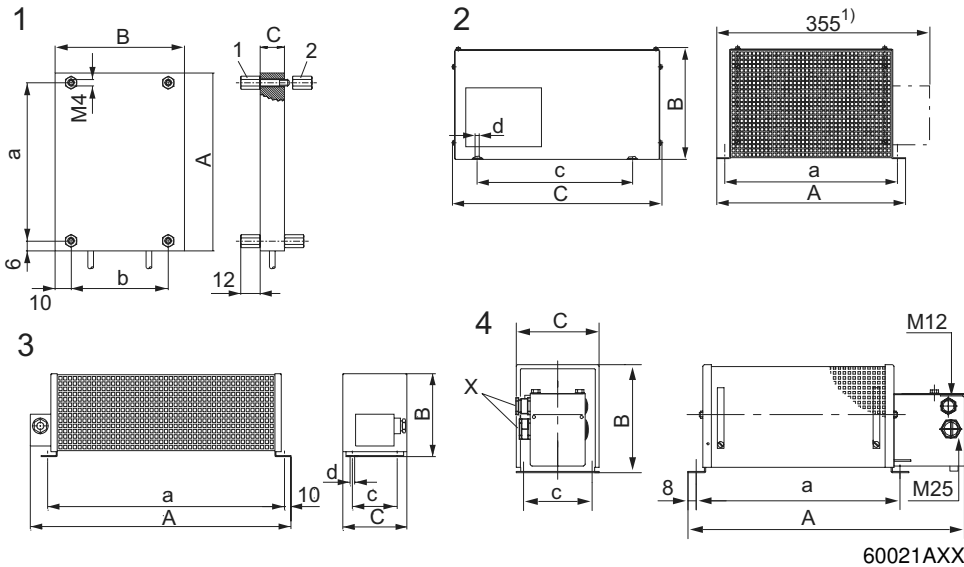

BW... :

- 1 = Flat design
The connecting lead is 500 mm long. The scope of delivery includes four M4 stud bolts each of type 1 and 2.
- 2 = Grid resistor
- 3 = Wire resistor
- 4 = Wire resistor with temperature switch (-T/-P)
Cable entry (X) is possible from both sides.

60021AXX

Type BW...	Mounting position	Main dimensions [mm]			Fastening parts [mm]			Cable gland	Weight [kg]
		A	B	C	a	b/c	d		
BW...-T / BW...-P									
BW106-T	2	795	270	490	770	380	10.5	-	32
BW206-T	2	995	270	490	970	380	10.5	-	40
BW012-025	2	295	260	490	270	380	10.5	-	8.0
BW012-025-P ¹⁾	2	295	260	490	270	380	10.5	M12 + M25	8.0
BW012-050-T	2	395	260	490	370	380	10.5	-	12
BW012-100-T	2	595	270	490	570	380	10.5	-	21
BW915-T	2	795	270	490	770	380	10.5	-	30
BW018-015	3	620	120	92	544	64	6.5	PG11	4.0
BW018-015-P	4	649	120	185	530	150	6.5	M12 + M25	5.8
BW018-035-T	2	295	270	490	270	380	10.5	-	9.0
BW018-075-T	2	595	270	490	570	380	10.5	-	18.5
BW027-006	3	486	120	92	430	64	6.5	PG11	2.2
BW027-012	3	486	120	185	426	150	6.5	PG11	4.3
BW039-003	3	286	120	92	230	64	6.5	PG11	1.5
BW039-006	3	486	120	92	430	64	6.5	PG11	2.2
BW039-012	3	486	120	185	426	150	6.5	PG11	4.3
BW039-012-T	4	549	120	185	426	150	6.5	M12 + M25	4.9
BW039-026-T	4	649	120	275	530	240	6.5	M12 + M25	7.5
BW039-050-T	2	395	260	490	370	380	10.5	-	12
BW147	3	465	120	185	426	150	6.5	PG13.5	4.3
BW147-T	4	549	120	185	426	150	6.5	M12 + M25	4.9
BW247	3	665	120	185	626	150	6.5	PG13.5	6.1
BW247-T	4	749	120	185	626	150	6.5	M12 + M25	9.2
BW347	3	670	145	340	630	300	6.5	PG13.5	13.2
BW347-T	4	749	210	185	630	150	6.5	M12 + M25	12.4
BW168	3	365	120	185	326	150	6.5	PG13.5	3.5
BW168-T	4	449	120	185	326	150	6.5	M12 + M25	3.6
BW268	3	465	120	185	426	150	6.5	PG13.5	4.3
BW268-T	4	549	120	185	426	150	6.5	M12 + M25	4.9
BW100-005	1	216	80	15	204	60	-	-	0.6
BW100-006	4	486	120	92	430	64	6.5	PG11	2.2
BW100-006-T	4	549	120	92	430	80	6.5	M12 + M25	3.0

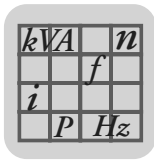

BS... touch guard Touch guards are available for braking resistors in flat design.

Touch guard	BS003	BS005
Part number	813 151 1	813 152 X
for braking resistor	BW027-003 BW072-003	BW027-005 BW072-005 BW100-005

Dimension drawing for touch guard BS...

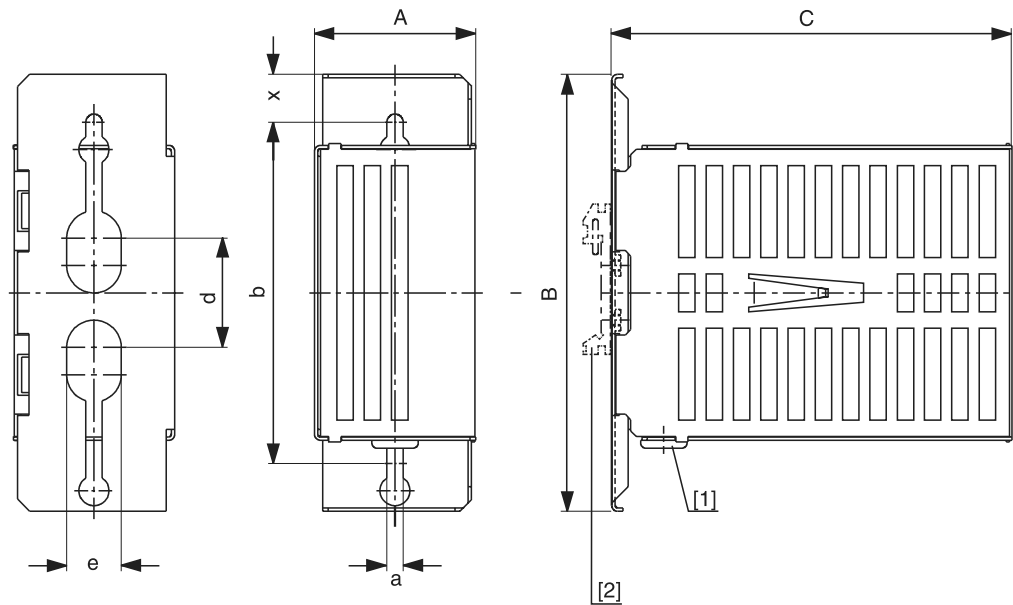

05247AXX

Figure 18: Dimension drawing for BS touch guard with grommet [1] and mounting rail attachment [2]

Type	Main dimensions [mm]			Mounting dimensions [mm]					Mass [kg]
	A	B	C	b	d	e	a	x	
BS-003	60	160	146	125	40	20	6	17.5	0.35
BS-005	60	160	252	125	40	20	6	17.5	0.5

Mounting rail installation

A mounting rail attachment HS001, part number 822 194 4, is available from SEW-EURODRIVE as an accessory for mounting the touch guard on a mounting rail.

DKB11A heat sink for brake resistors in flatpack design

Part number 814 345 5

Description

The DKB11A heat sink provides a space-saving means of mounting braking resistors in flatpack design (BW072-005, BW100-005) under MOVIDRIVE® size 1 (400/500 V units: 0015...0040; 230 V units: 0015...0037). The resistor is inserted into the heat sink and attached using the screws supplied (M4 × 20).

Dimension drawing

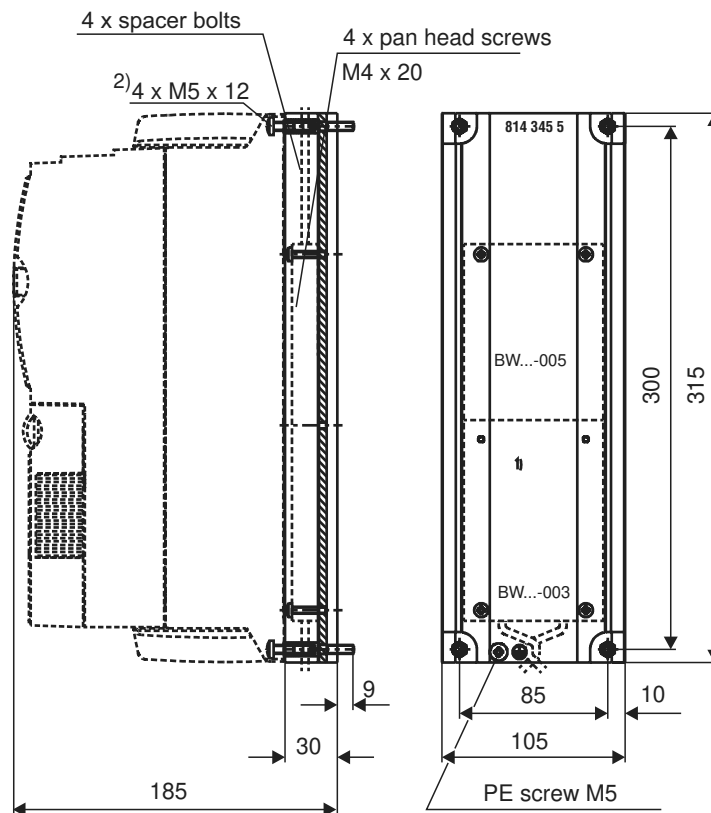
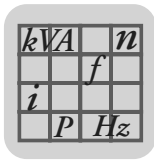

Figure 19: Dimension drawing for DKB11A heat sink, all dimensions in mm

60063AEN

- 1) Mounting surface for the braking resistor
- 2) Retaining screws are not included in the delivery scope



2.15 Line choke type ND..

- To increase overvoltage protection.
- To limit the charging current when several inverters are connected together in parallel on the input end with shared mains contactors (rated current of line choke = total of inverter currents).
- ND.. line filters have cRUus approval independent of the MOVDRIVE® drive inverters.

Line choke type	ND020-013	ND030-023 ¹⁾	ND045-013	ND085-013	ND150-013	ND200-0033
Part number	826 012 5	827 151 8	826 013 3	826 014 1	825 548 2	826 579 8
Rated voltage V_N	3 × AC 380 V -10 % ... 3 × AC 500 V +10 %, 50/60 Hz					
Rated current ²⁾ I_N	AC 20 A	AC 30 A	AC 45 A	AC 85 A	AC 150 A	AC 200 A
Power loss at I_N P_V	10 W	30 W	15 W	25 W	65 W	100 W
Inductance L_N	0.1 mH	0.2 mH	0.1 mH	0.1 mH	0.1 mH	0.03 mH
Ambient temperature ϑ_U	-25 °C ... +45 °C					
Enclosure	IP 00 (EN 60529)					
Connections	Terminal strips 4 mm ² (AWG12)	Terminal strips 2.5 mm ² ... 10 mm ² (AWG13 ... AWG8)	Terminal blocks 10 mm ² (AWG8)	Terminal blocks 35 mm ² (AWG2)	M10 stud PI: M8 stud	
Tightening torque	0.6 ... 0.8 Nm	max. 2.5 Nm		3.2 ... 3.7 Nm	M10 stud: 10 Nm PI: 6 Nm	
Assignment to AC 400/500 V units (...-5_3)						
Rated operation (100 %)	0015...0075	0110...0220		0300...0450 and MDR60A0370	0550/0750	MDR60A0750
Increased power (125 %)	0015...0075	0110/0150		0220...0370	0450...0750	
Assignment to AC 230 V units (...-2_3)						
Rated operation (100 %)	0015...0055	-	0075/0110	0150/0220	0300	-
Increased power (125 %)	0015...0037	-	0055/0075	0110/0150	0220/0300	-

- 1) You can implement ND030-023 for DC link connection without a regenerative power supply unit using connection type A or B (→ 'MOVDRIVE® MDR60A Regenerative Power Supply Unit' system manual)
- 2) If more than one MOVDRIVE® unit is connected to a line choke, the **total value of the rated currents** of the connected units **must not exceed the rated current of the line choke**.

Dimension drawings for ND...

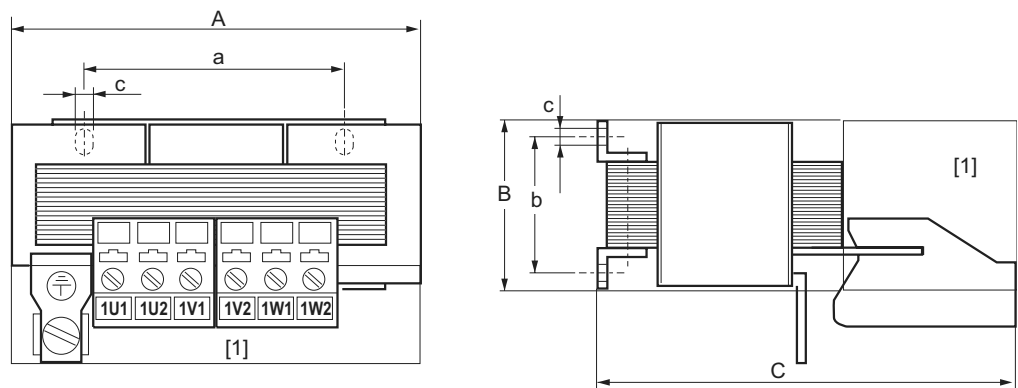

58699AXX

Figure 20: Dimension drawing for line chokes ND020.. / ND030.. / ND045.. / ND085..

(1) Space for installation terminals

Input: 1U1, 1V1, 1W1

Output: 1U2, 1V2, 1W2

Any mounting position

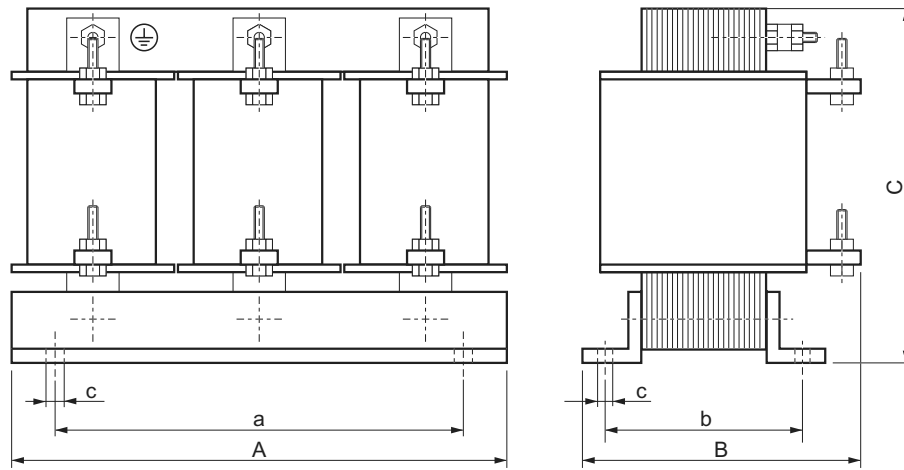
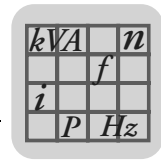

58315AXX

Figure 21: Dimension drawing for line chokes ND150.. / ND200..

All dimensions in mm:

Line choke type	Main dimensions			Mounting dimensions		Hole dimension c	Weight kg
	A	B	C	a	b		
ND020-013	85	60	120	50	31-42	5-10	0.5
ND030-023 ND045-013	125	95	170	84	55-75	6	2.5
ND085-013	185	115	235	136	56-88	7	8
ND150-013	255	140	230	170	77	8	17
ND200-0033	250	160	230	180	98	8	15

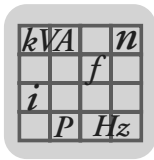

2.16 Line filter NF...-....

- To suppress interference emission on the line side of inverters.
- Do not switch between the NF... line filter and MOVDRIVE®.
- NF.. line filters have cRUus approval independent of the MOVDRIVE® drive inverters.

Line filter type	NF009-503	NF014-503	NF018-503	NF035-503	NF048-503
Part number	827 412 6	827,116 X	827 413 4	827 128 3	827 117 8
Rated voltage V_N	3 × AC 380 V –10 % ... AC 500 V +10 %, 50/60 Hz				
Rated current I_N	AC 9 A	AC 14 A	AC 18 A	AC 35 A	AC 48 A
Power loss at I_N P_V	6 W	9 W	12 W	15 W	22 W
Earth-leakage current at V_N	< 25 mA	< 25 mA	< 25 mA	< 25 mA	< 40 mA
Ambient temperature ϑ_U	–25 °C ... +40 °C				
Degree of protection	IP20 (EN 60529)				
Connections L1-L3/L1'-L3' PE	4 mm ² (AWG 10) M5 stud 0.8 Nm			10 mm ² (AWG 8) M5/M6 stud 1.8 Nm	
Tightening torque					
Assignment to AC 400/500 V units (...-5_3)					
Rated operation (100 %)	0015...0040	0055/0075	-	0110/0150	0220
Increased power (125 %)	0015...0030	0040/0055	0075	0110	0150
Assignment to AC 230 V units (...-2_3)					
Rated operation (100 %)	0015/0022	0037	-	0055/0075	0110
Increased power (125 %)	0015	0022	0037	0055/0075	-

Line filter type	NF063-503	NF085-503	NF115-503	NF150-503
Part number	827 414 2	827 415 0	827 416 9	827 417 7
Rated voltage V_N	3 × AC 380 V –10 % ... AC 500 V +10 %, 50/60 Hz			
Rated current I_N	AC 63 A	AC 85 A	AC 115 A	AC 150 A
Power loss at I_N P_V	30 W	35 W	60 W	90 W
Earth-leakage current at V_N	< 30 mA	< 30 mA	< 30 mA	< 30 mA
Ambient temperature ϑ_U	–25 °C ... +40 °C			
Degree of protection	IP20 (EN 60529)			
Connections L1-L3/L1'-L3' PE	16 mm ² (AWG 6) M6 3 Nm	35 mm ² (AWG 2) M8 3.7 Nm	50 mm ² (AWG1/0) M10 3.7 Nm	95 mm ² (AWG4/0) M10 3.7 Nm
Tightening torque				
Assignment to AC 400/500 V units (...-5_3)				
Rated operation (100 %)	0300	0370/0450	0550	0750
Increased power (125 %)	0220	0300/0370	0450	0550/0750
Assignment to AC 230 V units (...-2_3)				
Rated operation (100 %)	0150	0220	0300	-
Increased power (125 %)	0110/0150	-	0220/0300	-

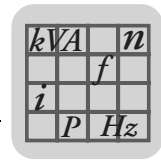

Dimension drawing for NF...

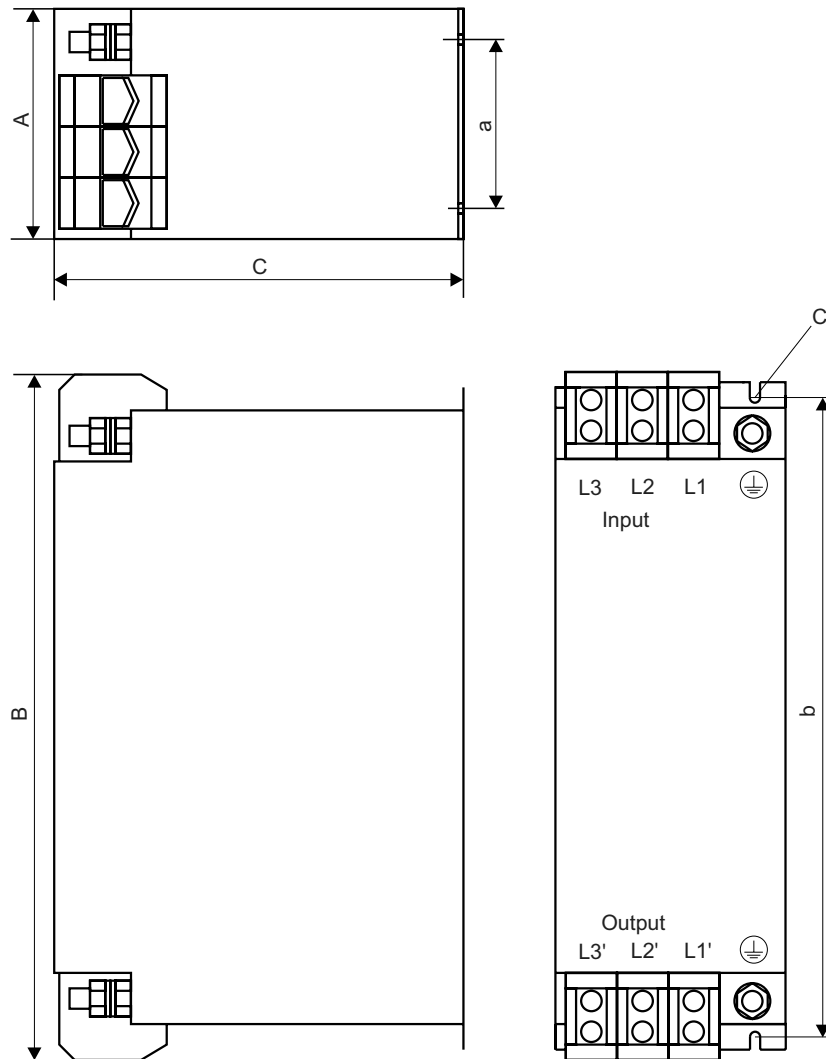

55862AEN

Any mounting position

All dimensions in mm:

Line filter type	Main dimensions			Mounting dimensions		Hole dimension c	PE connection	Weight kg
	A	B	C	a	b			
NF009-503	55	195	80	20	180	5.5	M5	0.8
NF014-503		225			210			0.9
NF018-503		255			240			1.1
NF035-503	60	275	100	30	255			M6
NF048-503		315			295	2.1		
NF063-503	90	260	140	60	235	6.5	M8	2.4
NF085-503		320						255
NF115-503	100	330	155	65	255			M10
NF150-503						5.6		

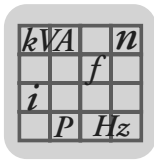

2.17 Output choke HD...

- For suppression of interference from the unshielded motor cable. We recommend routing the motor cable through the output choke with 5 loops. You can use less than 5 loops if the cable has a large diameter. Instead, connect 2 or 3 output chokes in series. If you use 4 loops, connect two output chokes in series, and if you use 3 loops, connect three output chokes.
- The output chokes are assigned to the motor cables using the cable cross sections. Consequently, there is no separate assignment table for AC 230 V units.

Output choke type	HD001 ¹⁾	HD002 ¹⁾	HD003 ¹⁾
Part number	813 325 5	813 557 6	813 558 4
Max. power loss P_{Vmax}	15 W	8 W	30 W
For cable cross sections/connections/ tightening torque	1.5...16 mm ² (AWG 16...6)	≤ 1.5 mm ² (AWG 16)	≥ 16 mm ² (AWG 6)

1) The HD... output choke is not a UL/cUL-relevant component.

Dimension drawing for HD...

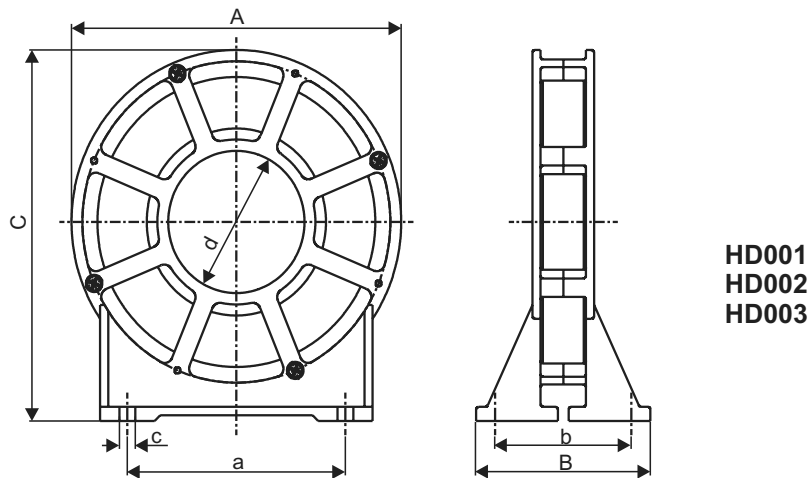

58419AXX

All dimensions in mm:

Output choke type	Main dimensions			Mounting dimensions		Inside \varnothing	Hole dimension c	Weight kg
	A	B	C	a	b			
HD001	121	64	131	80	50	50	5.8	0.5
HD002	66	49	73	44	38	23		0.2
HD003	170	64	185	120	50	88	7.0	1.1

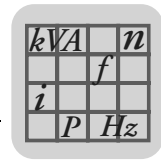

2.18 Output filter HF...

HF... output filters are sine filters used to smooth output voltage from inverters. HF... output filters (with the exception of HF450-503) are approved to UL/cUL in combination with MOVIDRIVE® drive inverters. HF... output filters are used in the following cases:

- In group drives (several motor cables in parallel); the discharge currents in the motor cables are suppressed.
- To protect the motor winding insulation of non-SEW motors which are not suitable for inverters
- For protection against overvoltage peaks in long motor cables (> 100 m).

NOTES	
	<ul style="list-style-type: none"> • Output filters can only be operated in V/f and VFC operating modes. Do not use output filters in CFC / SERVO operating modes. • Do not use output filters in hoist applications. • During project planning of the drive, take the voltage drop in the output filter into account and the reduced motor torque that results. This applies particularly to AC 230 V units with output filters.

Output filter type	HF015-503 ¹⁾	HF022-503 ¹⁾	HF030-503 ¹⁾	HF040-503 ¹⁾	HF055-503 ¹⁾
Part number	826 030 3	826 031 1	826 032 X	826 311 6	826 312 4
Rated voltage V_N	3 × AC 380 V –10 % ... 3 × AC 500 V +10 %, 50/60 Hz ²⁾				
Earth-leakage current at $V_N \Delta I$	0 mA				
Power loss at I_N P_V	35 W	55 W	65 W	90 W	115 W
Interference emission via unshielded motor cable	According to class B limit to EN 55011 and EN 55014 complies with EN 50081, parts 1 and 2				
Ambient temperature ϑ_U	0 °C ... +45 °C (reduction: 3 % I_N per K to max. 60 °C)				
Enclosure (EN 60529)	IP20				
Connections/tightening torque	M4 terminal studs 1.6 Nm ± 20 %				
Weight	4.4 kg			10.8 kg	
Assignment to AC 400/500 V units (...-5_3)					
Voltage drop at I_N ΔV	< 6.5 % (7.5 %) at AC 400 V / < 4 % (5 %) at AC 500 V and $f_{Amax} = 50$ Hz (60 Hz)				
Rated through current ³⁾ $I_{N 400 V}$ (at $V_{mains} = 3 \times AC 400 V$)	AC 4 A	AC 6 A	AC 8 A	AC 10 A	AC 12 A
Rated through current ³⁾ $I_{N 500 V}$ (at $V_{mains} = 3 \times AC 500 V$)	AC 3 A	AC 5 A	AC 6 A	AC 8 A	AC 10 A
Rated operation (100 %) ³⁾	0015	0022	0030	0040	0055
Increased power (125 %) ³⁾	-	0015	0022	0030	0040
Assignment to AC 230 V units (...-2_3)					
Voltage drop at I_N ΔV	< 18.5 % (19 %) at AC 230 V with $f_{Amax} = 50$ Hz (60 Hz)				
Rated through current ³⁾ $I_{N 230 V}$ (at $V_{mains} = 3 \times AC 230 V$)	AC 6.5 A	AC 10.8 A	AC 13 A	AC 17.3 A	AC 22 A
Rated operation (100 %) ³⁾	-	0015/0022	-	0037	0055
Increased power (125 %) ³⁾	-	0015/0022	-	-	0037

1) UL/cUL approval in combination with MOVIDRIVE® drive inverters. SEW-EURODRIVE will provide certification on request.

2) A reduction of 6 % I_N per 10 Hz applies above $f_{AN} = 60$ Hz for the rated through current I_N .

3) Only applies for operation without $V_{DC link}$ connection. For operation with $V_{DC link}$ connection, observe the project planning instructions in the MOVIDRIVE® compact system manual, section "Project Planning/Connecting the optional power components."

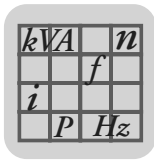

Output filter type	HF075-503 ¹⁾	HF023-403 ¹⁾	HF033-403 ¹⁾	HF047-403 ¹⁾	HF450-503
Part number	826 313 2	825 784 1	825 785 X	825 786 8	826 948 3
Rated voltage V_N	3 × AC 380 V -10 % ... 3 × AC 500 V +10 %, 50/60 Hz ²⁾				
Earth-leakage current at $V_N \Delta I$	0 mA				
Power loss at I_N P_V	135 W	90 W	120 W	200 W	400 W
Interference emission via unshielded motor cable	According to class B limit to EN 55011 and EN 55014 complies with EN 50081, parts 1 and 2				
Ambient temperature ϑ_U	0 °C ... +45 °C (reduction: 3 % I_N per K to max. 60 °C)				
Enclosure (EN 60529)	IP 20	IP20			IP 10
Connections/ tightening torque	M4 terminal studs 1.6 Nm ± 20 %	35 mm ² (AWG 2) 3.2 Nm			
Weight	10.8 kg	15.9 kg	16.5 kg	23 kg	32 kg
Assignment to AC 400/500 V units (...-5_3)					
Voltage drop at I_N ΔV	< 6.5 % (7.5 %) at AC 400 V / < 4 % (5 %) at AC 500 V and $f_{Amax} = 50$ Hz (60 Hz)				
Rated through current ³⁾ $I_{N 400 V}$ (at $V_{mains} = 3 \times AC 400 V$)	AC 16 A	AC 23 A	AC 33 A	AC 47 A	AC 90 A
Rated through current ³⁾ $I_{N 500 V}$ (at $V_{mains} = 3 \times AC 500 V$)	AC 13 A	AC 19 A	AC 26 A	AC 38 A	AC 72 A
Rated operation (100 %) ³⁾	0075	0110	0150/0300 ⁴⁾	0220	0370/0450/ 0550 ⁴⁾ /0750 ⁴⁾
Increased power (125 %) ³⁾	0055	0075	0110/0220 ⁴⁾	0150	0300/0370/0450/ 0550 ⁴⁾ /0750 ⁴⁾
Assignment to AC 230 V units (...-2_3)					
Voltage drop at I_N ΔV	< 18.5 % (19 %) at AC 230 V with $f_{Amax} = 50$ Hz (60 Hz)				
Rated through current ³⁾ $I_{N 230 V}$ (at $V_{mains} = 3 \times AC 230 V$)	AC 29 A	AC 42 A	AC 56.5 A	AC 82.6 A	AC 156 A
Rated operation (100 %) ³⁾	0075	0110	0150/0300 ⁴⁾	0220	0300
Increased power (125 %) ³⁾	0055	0075	0110/0220 ⁴⁾	0150	0220/0300

- 1) UL/cUL approval in combination with MOVIDRIVE® drive inverters. SEW-EURODRIVE will provide certification on request.
- 2) A reduction of 6 % I_N per 10 Hz applies above $f_{AN} = 60$ Hz for the rated through current I_N .
- 3) Only applies for operation without $V_{DC link}$ connection. For operation with $V_{DC link}$ connection, observe the project planning instructions in the MOVIDRIVE® compact system manual, section "Project Planning/Connecting the optional power components."
- 4) Connect **two HF.... output filters in parallel** for operation with these MOVIDRIVE® units.

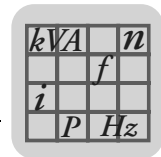

Dimension drawings for output filter HF...-503, all dimensions in mm

HF008/015/022/030-503

HF040/055/075-503

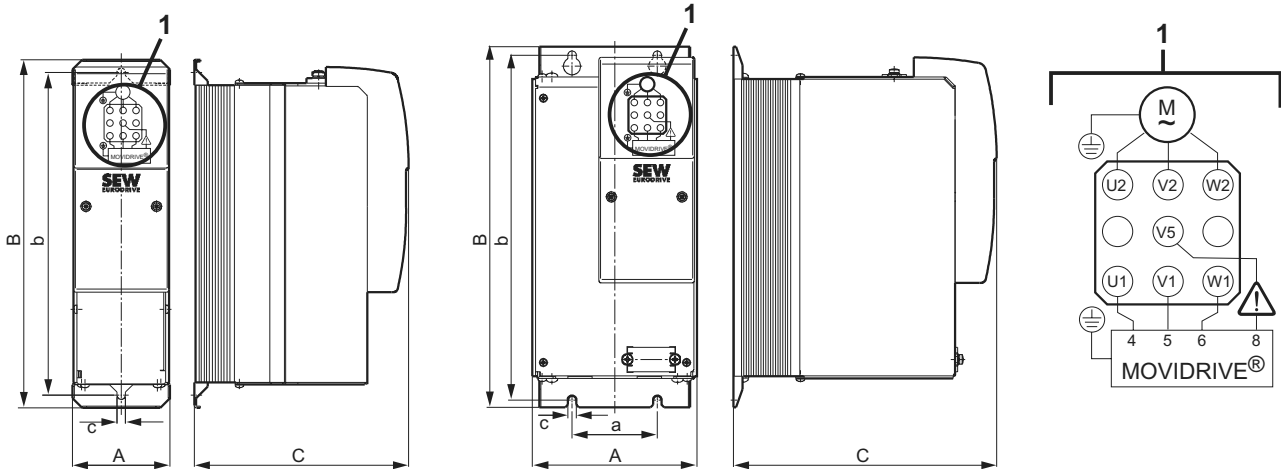

58418AXX

Figure 22: Dimension drawings for output filters HF008...075-503

Only the mounting position shown in the dimension drawing is permitted.

Output filter type	Main dimensions			Mounting dimensions		Hole dimension c	Ventilation clearances ¹⁾	
	A	B	C	a	b		Above	Below
HF008/015/022/030-503	80	286	176	-	265	7	100	100
HF040/055/075-503	135	296	216	70	283			

1) There is no need for clearance at the sides. You can line up the units next to one another.

HF450-503

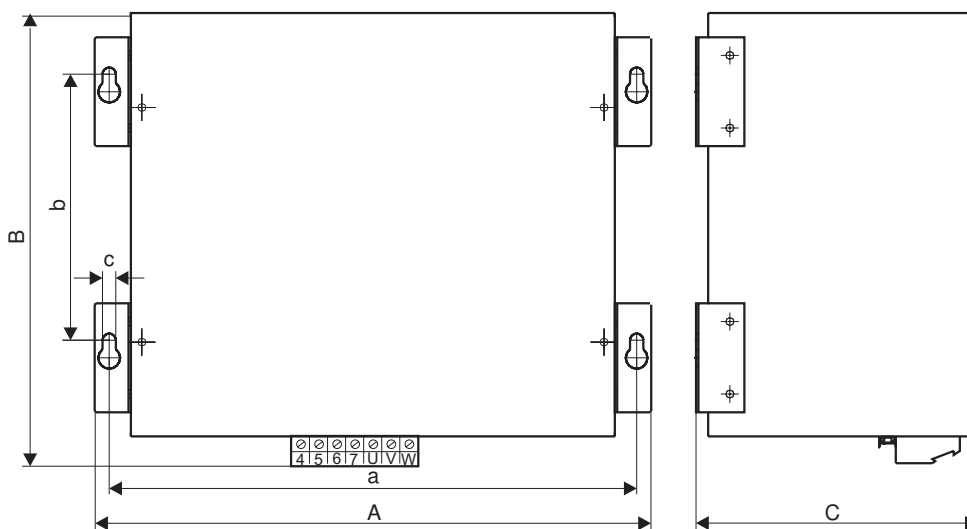

58417AXX

Figure 23: Dimension drawing for output filter HF450-503

Only the mounting position shown in the dimension diagram is permitted

Output filter type	Main dimensions			Mounting dimensions		Hole dimension c	Ventilation clearances	
	A	B	C	a	b		Above	Below
HF450-503	465	385	240	436	220	8.5	100	100

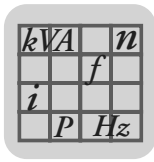

Dimension drawing for HF...-403 output filter, dimensions in mm

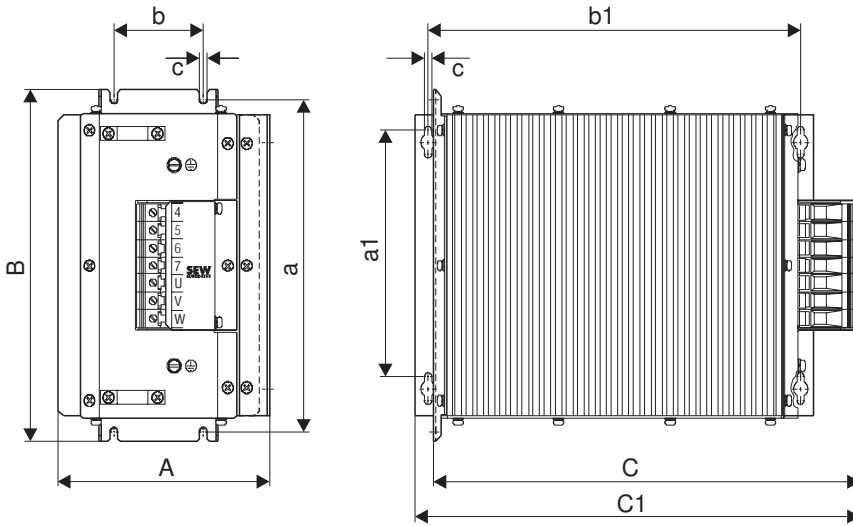
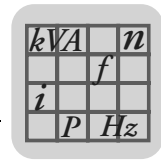

Figure 24: Dimension drawing for HF...-403 output filter

58996AXX

Type	Main dimensions			Mounting dimensions				Hole dimension c	Ventilation clearances		
				Standard mounting position		Horizontal mounting position					
	A	B	C/C1	a	b	a1	a2		Side	Above	Below
HF023-403	145	284	365/390	268	60	210	334	6.5	30 each	150	150
HF033-403											
HF047-403	190	300	385/400	284	80						



2.19 Prefabricated cables

Overview

SEW-EURODRIVE offers cable sets and prefabricated cables for straightforward and fault-free connection of various system components to MOVIDRIVE®. The cables are prefabricated in 1 m steps to the required length. It is necessary to differentiate between whether the cables are intended for fixed routing or for cable carrier applications.

1. Cable sets for DC link connection MDR → MCF/MCV/MCS/MCH
2. Motor cables and extension cables for connecting CM motors to MCS and MCH
3. Motor cables for connecting DS motors to MCS
4. VR forced cooling fan cable and extension cable
5. Connection to X14/X15 of the MCV / MCS / MCH basic unit: Encoder cables and extension cables (Hiperface, incremental encoder), resolver cables and extension cables in connector and terminal box design for motors for connecting the motor encoder to encoder input X15 of the MCV basic unit or to "X2: Encoder" of the 5 V encoder supply type DWI11A.

1. Cable sets for DC link connection MDR → MCF/MCV/MCS/MCH

Description

SEW-EURODRIVE strongly recommends using the cable sets listed in the table below. These cable sets offer the appropriate dielectric strength and are also color-coded. Color coding is necessary because cross-polarity and ground faults could cause irreparable damage to the connected equipment.

The length of the cables restricts the DC link connection to the permitted length of 5 m. They can also be cut to length by the customer for connecting several units. The lugs for connection to the regenerative power supply unit and an inverter are supplied with the cable set. Use commercially available cable lugs to connect other inverters. In this case, connect inverters in star configuration to the regenerative power supply unit. Use a busbar subdistributor if the DC link terminals of the regenerative power supply unit are not sufficient.

Installation type

Only fixed routing is possible.

Cable set type	DCP12A	DCP13A	DCP15A
Part number	814 567 9	814 250 5	814 251 3
For connecting MOVIDRIVE®	0015...0110	0150...0370	0450...0750

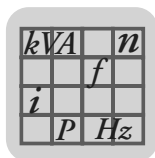

2. Motor cables for connecting CM motors to MCS and MCH and extension cables

Motor cables

The cables are equipped with a connector for motor connection and conductor end sleeves for inverter connection.

Number of cores and line cross section	Part number	Installation type	For motor
4×1.5 mm ²	199 179 5	Fixed installation	CM..SM51
4×1.5 mm ² + 3×1.0 mm ²	199 189 2		CM..BR SB51
4×2.5 mm ²	199 181 7		CM..SM52
4×2.5 mm ² + 3×1.0 mm ²	199 191 4		CM..BR SB52
4×4 mm ²	199 183 3		CM..SM54
4×4 mm ² + 3×1.0 mm ²	199 193 0		CM..BR SB54
4×6 mm ²	199 185 X		CM..SM56
4×6 mm ² + 3×1.5 mm ²	199 195 7		CM..BR SB56
4×10 mm ²	199 187 6		CM..SM59
4×10 mm ² + 3×1.5 mm ²	199 197 3		CM..BR SB59

Number of cores and line cross section	Part number	Installation type	For motor
4×1.5 mm ²	1 333 114 0	Cable carrier installation	CM..SM51
4×1.5 mm ² + 3×1.0 mm ²	1 333 116 7		CM..BR SB51
4×2.5 mm ²	1 333 115 9		CM..SM52
4×2.5 mm ² + 3×1.0 mm ²	1 333 117 5		CM..BR SB52
4×4 mm ²	199 184 1		CM..SM54
4×4 mm ² + 3×1.0 mm ²	199 194 9		CM..BR SB54
4×6 mm ²	199 186 8		CM..SM56
4×6 mm ² + 3×1.5 mm ²	199 196 5		CM..BR SB56
4×10 mm ²	199 188 4		CM..SM59
4×10 mm ² + 3×1.5 mm ²	199 198 1		CM..BR SB59

Extension cables

The cables are equipped with a connector and adapter for extending the CM motor cable.

Number of cores and line cross section	Part number	Installation type	For motor
4×1.5 mm ²	199 549 9	Fixed installation	CM..SM51
4×1.5 mm ² + 3×1.0 mm ²	199 199 X		CM..BR SB51
4×2.5 mm ²	199 551 0		CM..SM52
4×2.5 mm ² + 3×1.0 mm ²	199 201 5		CM..BR SB52
4×4 mm ²	199 553 7		CM..SM54
4×4 mm ² + 3×1.0 mm ²	199 203 1		CM..BR SB54
4×6 mm ²	199 555 3		CM..SM56
4×6 mm ² + 3×1.5 mm ²	199 205 8		CM..BR SB56
4×10 mm ²	199 557 X		CM..SM59
4×10 mm ² + 3×1.5 mm ²	199 207 4		CM..BR SB59

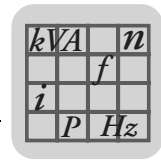

Number of cores and line cross section	Part number	Installation type	For motor
4×1.5 mm ²	1 333 118 3	Cable carrier installation	CM..SM51
4×1.5 mm ² + 3×1.0 mm ²	1 333 120 5		CM..BR SB51
4×2.5 mm ²	1 333 119 1		CM..SM52
4×2.5 mm ² + 3×1.0 mm ²	1 333 121 3		CM..BR SB52
4×4 mm ²	199 554 5		CM..SM54
4×4 mm ² + 3×1.0 mm ²	199 204 X		CM..BR SB54
4×6 mm ²	199 556 1		CM..SM56
4×6 mm ² + 3×1.5 mm ²	199 206 6		CM..BR SB56
4×10 mm ²	199 558 8		CM..SM59
4×10 mm ² + 3×1.5 mm ²	199 208 2	CM..BR SB59	

3. Motor cables for connecting DS motors to MCS

Description The cables are equipped with a connector for motor connection and conductor end sleeves for inverter connection.

Number of cores and line cross section	Part number	Installation type	For motor
4×1.5 mm ²	590 454 4	Fixed installation	DS56 / SM11
4×1.5 mm ² + 2×1 mm ²	1 332 485 3		DS56..B / SB11
4×2.5 mm ²	590 455 2		DS56 / SM12
4×2.5 mm ² + 2×1 mm ²	1 333 213 9		DS56..B / SB12
4×4 mm ²	590 456 0		DS56 / SM14
4×4 mm ² + 2×1 mm ²	1 333 214 7		DS56..B / SB14

Number of cores and line cross section	Part number	Installation type	For motor
4×1.5 mm ²	590 624 5	Cable carrier installation	DS56 / SM11
4×1.5 mm ² + 2×1 mm ²	1 333 122 1		DS56..B / SB11
4×2.5 mm ²	590 625 3		DS56 / SM12
4×2.5 mm ² + 2×1 mm ²	1 333 215 5		DS56..B / SB12
4×4 mm ²	590 480 3		DS56 / SM14
4×4 mm ² + 2×1 mm ²	1 333 216 3		DS56..B / SB14

4. VR forced cooling fan cables and extension cables

VR forced cooling fan cables:

Number of cores and line cross section	Part number	Installation type
3×1 mm ²	198 634 1	Fixed installation
3×1 mm ²	199 560 X	Cable carrier installation

Extension cables for the VR forced cooling fan cable:

Number of cores and line cross section	Part number	Installation type
3×1 mm ²	199 561 8	Fixed installation
3×1 mm ²	199 562 6	Cable carrier installation

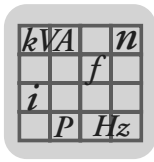





5. Prefabricated cables for connection to X14/X15 on MCV / MCS / MCH basic units

The overviews on the following pages show all the connection options for X14/X15 on MCV / MCS / MCH basic units.

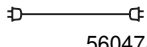
Meaning of the symbols

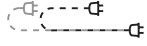
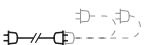
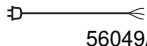
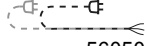
The connection cables are assigned a part number and a symbol. The symbols have the following meaning:

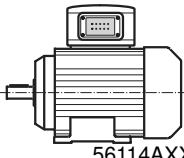
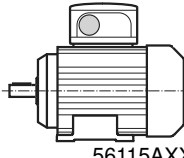
Symbol	Meaning
 56047AXX	Connection cable connector → connector for fixed installation
 56051AXX	Extension connection cable connector → connector for fixed installation
 56048AXX	Connection cable connector → connector for cable carrier installation
 56052AXX	Extension connection cable connector → connector for cable carrier installation
 56049AXX	Connection cable connector → terminal box for fixed installation
 56050AXX	Connection cable connector → terminal box for cable carrier installation
 56112AXX	Encoder connection via plug connector
 56113AXX	Encoder connection via encoder terminal strip
 56114AXX	Connection via plug connector on the motor side
 56115AXX	Connection via terminal box on the motor side

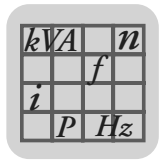

Connection options for X15 on the MCV basic unit

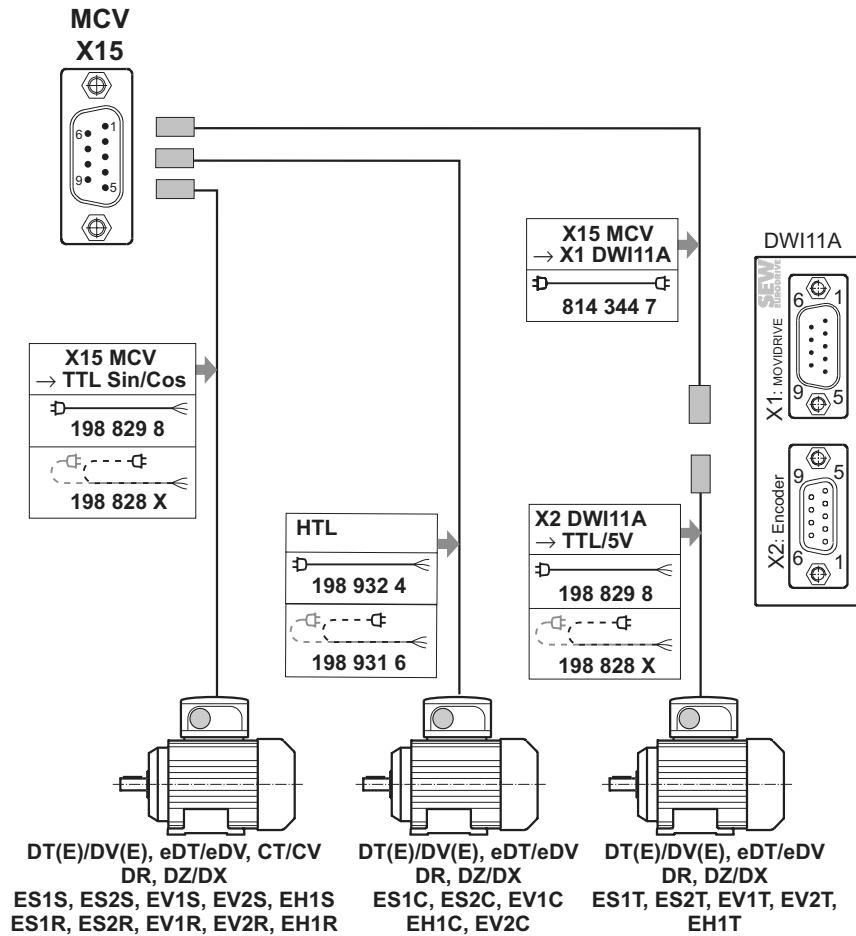

60069AXX



NOTE

For individual wiring diagrams, refer to the section "Installation" in the MOVIDRIVE® compact operating instructions.

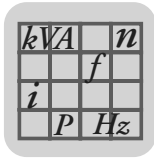

Technical Data and Dimension Drawings
Prefabricated cables

- Cable to connect sin/cos encoders ES1S, ES2S, EV1S, EV2S, EH1S, ES1R, ES2R, EV1R, EV2R, EH1R with terminal box connection on the motor side to CT, CV, DT(E), DV(E), eDT, eDV, DR, DZ and DX motors.

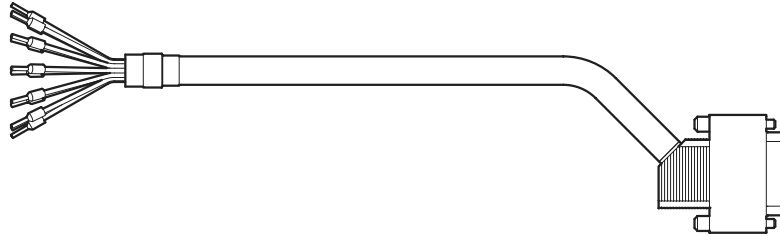

56132AXX

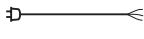
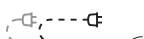
Type	Installation	Part number
MCV X15 → DT(E)/DV(E)/eDT/eDV/CT/CV/DR/DZ/DX motors with sin/cos encoders ES1S, ES2S, EV1S, EV2S, EH1S, ES1R, ES2R, EV1R, EV2R, EH1R	 56049AXX	198 829 8
	 56050AXX	198 828 X

- Cable to connect single-ended HTL encoders ES1C, ES2C, EV1C, EV2C, EH1C with terminal box connection on the motor side to DT(E), DV(E), eDT, eDV, DR, DZ and DX motors.

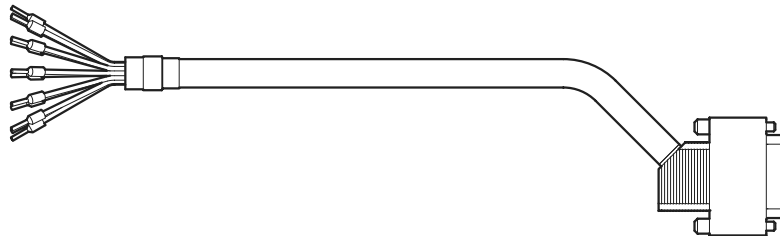

56132AXX

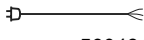
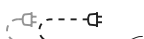
Type	Installation	Part number
HTL encoders ES1C, ES2C, EV1C, EV2C, EH1C → DT(E)/DV(E)/eDT/eDV/DR/DZ/DX motors	 56049AXX	198 932 4
	 56050AXX	198 931 6

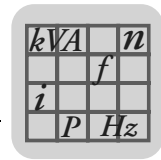

- Cable to connect DC 5 V TTL sensors ES1T, ES2T, EV1T, EV2T, EH1T with terminal box connection on the motor side (DT(E), DV(E), eDT, eDV, DR, DZ or DX motors) to DC 5 V encoder power supply type DWI11A.

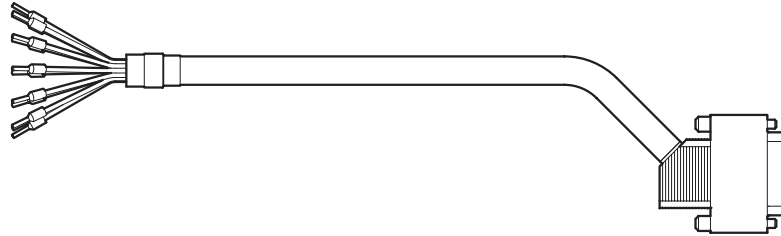

56132AXX

Type	Installation	Part number
DC 5 V TTL sensors ES1T, ES2T, EV1T, EV2T, EH1T → DWI11A X2	 56049AXX	198 829 8
	 56050AXX	198 828 X

- Cable to connect the DC 5 V encoder power supply type DWI11A via plug connector.

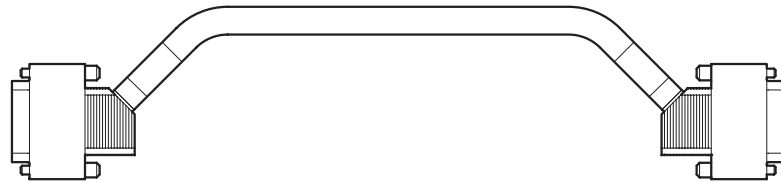

56109AXX

Type	Installation	Part number
MCV X15 → DWI11A X1	 56047AXX	814 344 7

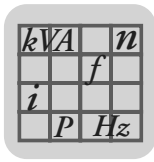

Connection options for X15 on the MCS basic unit

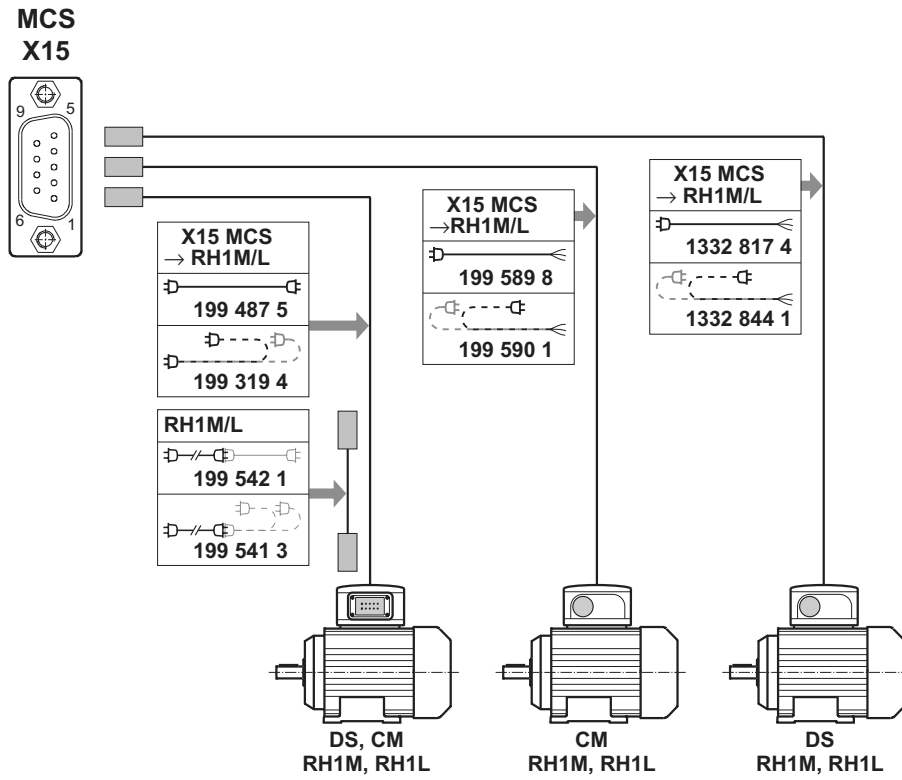

60072AXX

	NOTE
	For individual wiring diagrams, refer to the section "Installation" in the MOVIDRIVE® compact operating instructions.

- Cable to connect resolvers RH1M / RH1L with plug connector connection on the motor side to DS, CM, CMD or CMP motors.



56138AXX

Type	Installation	Part number
MCS X15 → DS/CM motors with RH1M/RH1L	56047AXX	199 487 5
	56048AXX	199 319 4

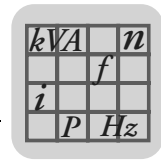

- Extension cable to connect RH1M / RH1L resolvers with plug connector connection on the motor side to DS or CM motors.

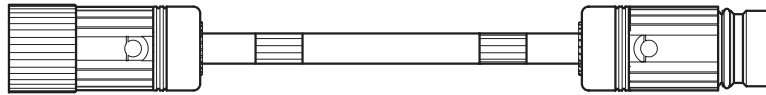

56139AXX

Type	Installation	Part number
MCS X15 → DS/CM motors with RH1M/RH1L	 56051AXX	199 542 1
	 56052AXX	199 541 3

- Cable to connect resolvers RH1M / RH1L with terminal box connection on the motor side to CM and DS motors.

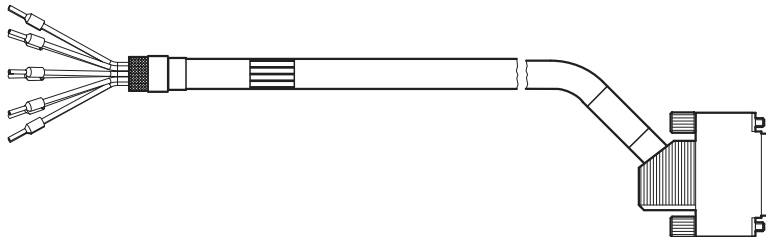

56142AXX

Type	Installation	Part number
MCS X15 → CM motors with RH1M/RH1L	 56049AXX	199 589 8
	 56050AXX	199 590 1
MCS X15 → DS motors with RH1M/RH1L	 56049AXX	1332 817 4
	 56050AXX	1332 844 1

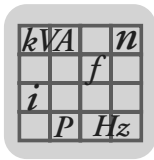

Connection options for X15 on the MCH basic unit

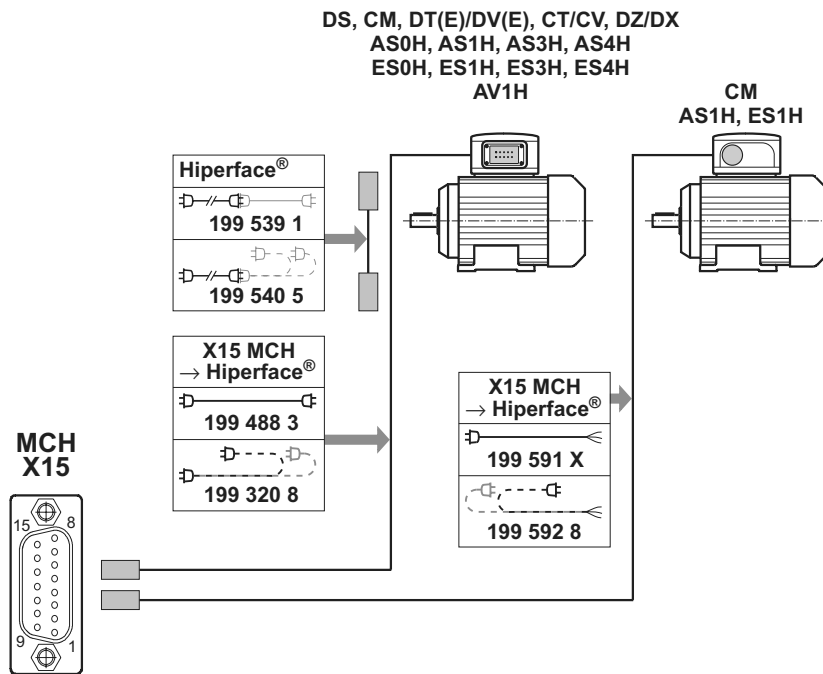

60070AXX

	NOTE
	For individual wiring diagrams, refer to the section "Installation" in the MOVIDRIVE® compact operating instructions.

- Cable to connect HIPERFACE® encoders AK0H, AS1H, AS3H, AS4H, EK0H, ES1H, ES3H, ES4H, EV1H, AV1H with plug connector connection on the motor side to DS, CM, DT, DV, DT(E), DV(E), CT, CV, DZ or DX motors.

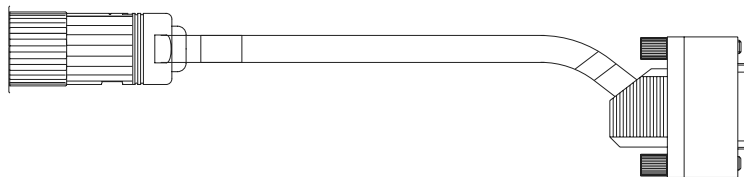

56135AXX

Type	Installation	Part number
MCH X15 → DS/CM/DT/DV/DT(E)/DV(E)/CT/CV/DZ/DX motors with AK0H, AS1H, AS3H, AS4H, EK0H, ES1H, ES3H, ES4H, EV1H, AV1H	56047AXX	199 488 3
	56048AXX	199 320 8

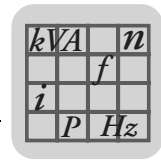

- Extension cable to connect HIPERFACE® encoders AK0H, AS1H, AS3H, AS4H, EK0H, ES1H, ES3H, ES4H, EV1H, AV1H with plug connector connection on the motor side to DS, CM, DT, DV, DT(E), DV(E), CT, CV, DZ or DX motors.

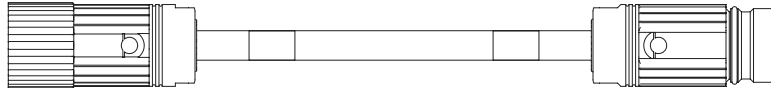

56136AXX

Type	Installation	Part number
MCH X15 → DS/CM/DT/DV/DT(E)/DV(E)/CT/CV/DZ/DX motors with AK0H, AS1H, AS3H, AS4H, EK0H, ES1H, ES3H, ES4H, EV1H, AV1H	 56051AXX	199 539 1
	 56052AXX	199 540 5

- Cable to connect HIPERFACE® encoders AS1H, ES1H with terminal box connection on the motor side to CM motors.

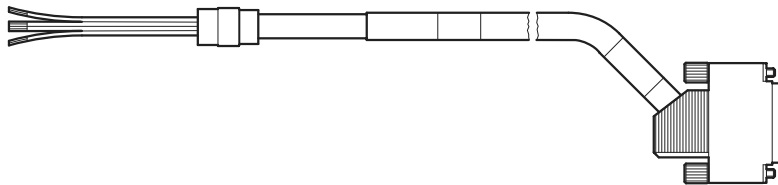

56137AXX

Type	Installation	Part number
MCH X15 → CM motors with AS1H, ES1H	 56049AXX	199 591 X
	 56050AXX	199 592 8

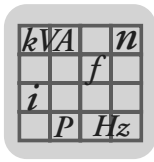

Connection options for X14 on MCV/MCS basic unit

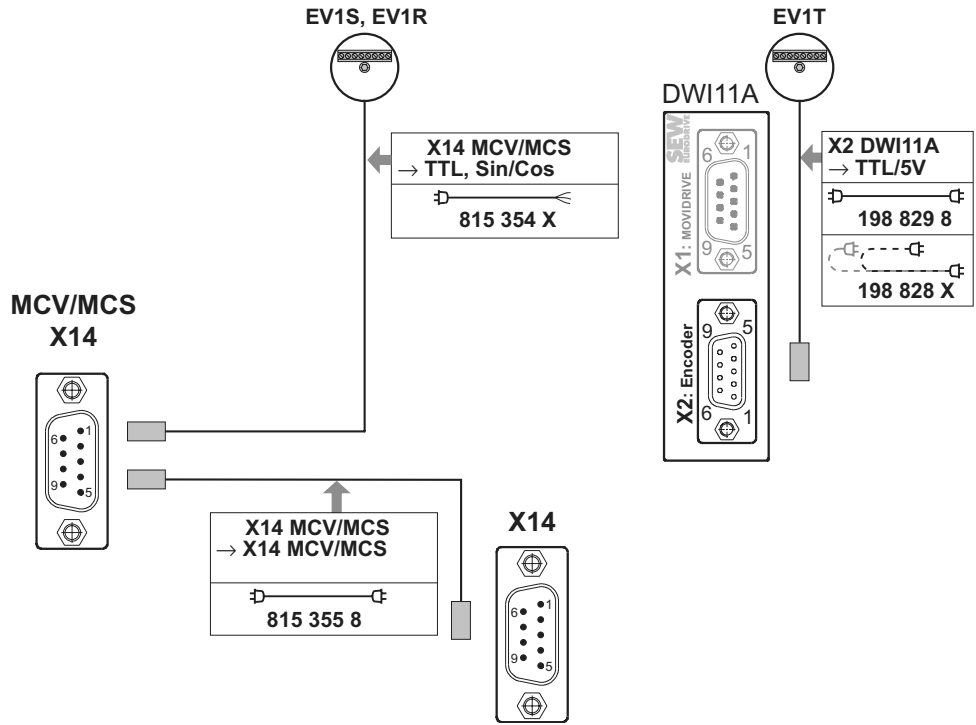

60071AXX

	NOTE
	For individual wiring diagrams, refer to the section "Installation" in the MOVIDRIVE® compact operating instructions.

- Cable to connect external sin/cos encoders via encoder terminal strip.

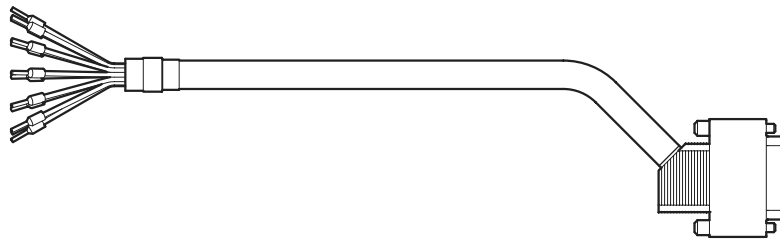

56132AXX

Type	Installation	Part number
MCV / MCS X14 → TTL-, sin/cos encoder	 56049AXX	815 354 X

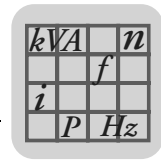

- Cable to connect an external DC 5 V TTL sensor to the DC 5 V encoder power supply type DWI11A via encoder terminal strip.

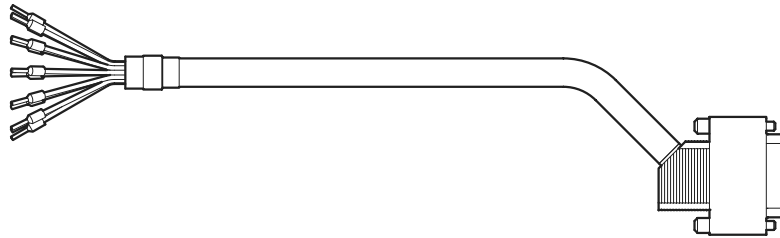

56132AXX

Type	Installation	Part number
DC 5 V TTL sensor → DWI11A X2	 56049AXX	198 829 8
	 56050AXX	198 828 X

- Cable to connect a master/slave connection.

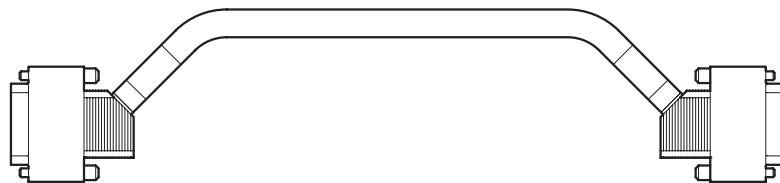

56109AXX

Type	Installation	Part number
MCV/MCS X14 → MCV/MCS X14	 56047AXX	815 355 8



3 Motor Selection

3.1 Motor selection for asynchronous AC motors (VFC)

Basic recommendations

- Only use motors with at least thermal class F.
- Use TF thermistors or TH winding thermostats. TH should be preferred for group drives on one inverter. The series connection of the TH contacts (normally closed) is not subject to limitation when both monitoring functions are used.
- For group drives, we recommend that the motors should not differ from one another by more than 3 motor types.
- Use 4-pole motors if possible. This recommendation applies particularly to gear-motors operated with a high oil filling level due to their vertical mounting position.
- Generally speaking, the motor can be operated at its listed power without forced cooling if the operating conditions differ from S1 operation, e.g. positioning drive with 1:20 speed range in S3 operation.
- Do not select a motor that is too big, particularly for delta connection. Otherwise, the inverter may trigger a short circuit fault.
- A MOVIDRIVE® compact MCV4_A or MCH4_A drive inverter is required for speed control. In this case, the motor must be equipped with an incremental encoder, preferably with 1024 increments/revolution or with a Hiperface encoder.

Voltage/frequency characteristic curve

The VFC operating mode runs the asynchronous motor on a load-dependent voltage/frequency curve. The continuous calculation of the motor model enables the full motor torque to be utilized right down to the lowest speeds. This characteristic curve is set by entering the rated motor voltage and the rated motor frequency in the startup function. The setting determines the speed-dependent torque and power characteristics of the asynchronous motor.

The following figure shows an example of the voltage/frequency characteristic curve of an asynchronous AC motor 230/400 V, 50 Hz.

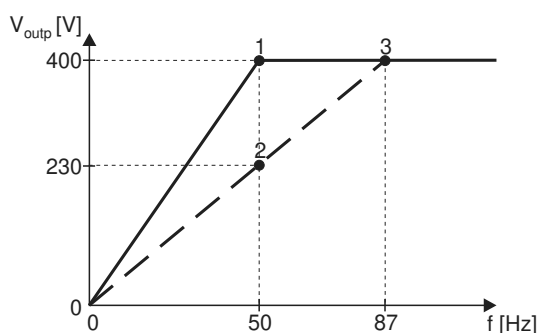

Figure 25: Voltage/frequency characteristics of the asynchronous motor

01650BEN

- 1 Star connection; 400 V, 50 Hz
- 2 Delta connection: 230 V, 50 Hz
- 3 Delta connection: 400 V, 87 Hz

The inverter output voltage V_{out} is limited by the connected supply voltage. The "rated supply voltage" input value in the startup function limits the effective value of the maximum output voltage. This restriction is used whenever the connected motor has a lower rated voltage than the power supply of the inverter. Enter the maximum permitted motor voltage. Furthermore, make sure that the "rated supply voltage" input value is less than or equal to the supply voltage of the inverter.



Speed/torque characteristic curve

The field weakening range starts when the set maximum output voltage of the inverter is reached. Consequently, the speed range of the motor is divided into two ranges:

- Basic speed range → constant torque with increasing power.
- Field weakening range → constant power with an inversely proportionate decrease in torque.

When determining the maximum speed in the field weakening range, note that the rated torque M_N (in relation to the rated speed, e.g. $n_N = 1,500$ 1/min) falls in inverse proportion and the breakdown torque M_K is reduced in an inverse quadratic relationship. The M_K/M_N ratio is a motor-specific parameter. The MOVIDRIVE® breakdown protection limits the speed when the maximum possible torque is reached.

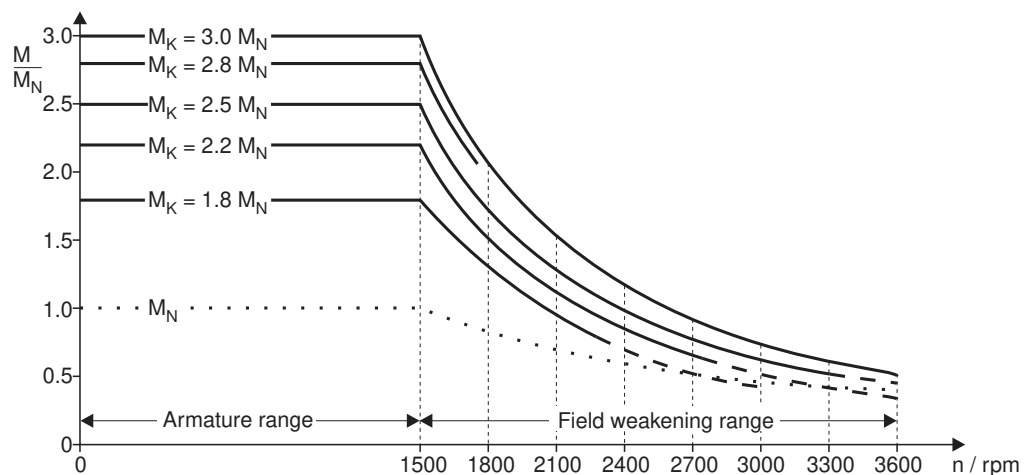

01729BEN

Figure 26: Quadratically falling breakdown torque

With gearmotors, the maximum motor speed depends on the size and mounting position of the gear unit. The speed should not exceed 3,000 1/min due to the resulting noise and oil churning losses.

Dynamic applications ($P_{inverter}$ greater than P_{motor})

- The startup function sets the current limit of the inverter (P303/P313) to 150 % of the rated motor current. The value of the current limit is based on the rated inverter current. 150% of the rated motor current is, therefore, less than 150 % of the rated inverter current (value of P303 P313). For dynamic applications, this parameter must be set manually to a higher value.
- The startup function sets the slip compensation parameter (P324/P334) to the rated slip of the motor. In the case of VFC-n-CONTROL, the internal slip limiting function allows the slip to reach max. 150 % of this setting. Consequently, the motor develops at most 150 % of the rated motor torque. For higher torque ratings, the slip compensation parameter (P324) must be increased accordingly.

	NOTE
	Set parameter P324 "Slip compensation" to max. 130 % of the rated slip of the motor for stable operation.



Motor Selection

Motor selection for asynchronous AC motors (VFC)

**Combinations
with $P_{inverter}$
greater than $4 \times$
 P_{motor}**

Due to the great difference between the rated inverter and rated motor currents, this combination cannot be started without additional measures:

- Perform project planning for connecting the motor in a delta connection. This increases the motor current by a factor of $\sqrt{3}$ and lowers the unfavorable ratio.
- If this measure does not suffice, start up the motor in VFC & GROUP operating mode. In this operating mode, the inverter operates without slip compensation and simulates a constant-voltage/ constant-frequency system (system with a constant V/f ratio).



Motor selection in connection type delta/star (AC 230/400 V / 50 Hz)

Motors for AC 380 V / 60 Hz can also be allocated on the basis of this selection table.

P _{max} [kW] for operation on MOVIDRIVE® compact MCF/MCV/MCH 4_A...-5_3 (AC 400/500 V units)							
Connection		Δ / AC 400 V ¹⁾			Δ / AC 230 V ²⁾		
Cooling		Own	Forced		Own	Forced	
f _{min} - f _{max} [Hz]		10 - 50 6 - 60 5 - 70 / 5.5 - 80	≤ 2.5 - 50 / ≤ 3 - 60 ³⁾		9 - 87	≤ 2.5 - 87 ³⁾	
n _{min} - n _{max} [1/min]		300 - 1500 180 - 1800 150 - 2100 / 165 - 2400	≤ 75 - 1500 / ≤ 90 - 1800		270 - 2610	≤ 75 - 2610	
Setting range		1:5 1:10 1:15	≥ 1:20		1:10	≥ 1:20	
Motor type	Rated power P _n [kW]	P = P _{reduced}		P = P _n		P = P _{increased} ⁴⁾	
		[kW]	MCF/MCV/MCH ⁵⁾ 4_A...-5_3	[kW]	MCF/MCV/MCH ⁵⁾ 4_A...-5_3	[kW]	MCF/MCV/MCH ⁵⁾ 4_A...-5_3
DT71D4	0.37	0.25	0015	0.37	0015	0.55	0015
DT80K4	0.55	0.37		0.55			
DT80N4	0.75	0.55		0.75			
DT90S4	1.1	0.75		1.1			
DT90L4	1.5	1.1		1.5			
DV100M4	2.2	1.5		2.2	0022	3.0	0030
DV100L4	3.0	2.2	0022	3.0	0030	4.0	0040
DV112M4	4.0	3.0	0030	4.0	0040	5.5	0055
DV132S4	5.5	4.0	0040	5.5	0055	7.5	0075
DV132M4	7.5	5.5	0055	7.5	0075	9.2	0110
DV132ML4	9.2	7.5	0075	9.2	0110	11	
DV160M4	11	9.2	0110	11		0150	15
DV160L4	15	11		15	18.5		0220
DV180M4	18.5	15	0150	18.5	0220	22	0300
DV180L4	22	18.5	0220	22		30	0370
DV200L4	30	22		30	0300	37	
DV225S4	37	30	0300	37	0370	45	0450
DV225M4	45	37	0370	45	0450	55	0550
DV250M4	55	45	0450	55	0550	75	0750
DV280S4	75	55	0550	75	0750		
DV280M4	90	75	0750				

- 1) Also applies to motors with rated voltage 460 V or 500 V and for motors 400/690 V with Δ connection.
- 2) Also applies to motors with 266 V or 290 V rated voltage.
- 3) The following applies to MCF, MCV and MCH without speed control: f_{min} = 0.5 Hz
- 4) P_{increased} means that the motor is operated at the power of the next larger motor (one frame size), rather than with √3-fold power.
- 5) The units listed here permit intermittent loads of up to 1.5 times the rated load in the specific application. With variable torque load and constant load without overload, each inverter can also be operated with increased continuous output power (→ Sec. Technical Data). The continuous output current of 125% of the rated unit current is only available at f_{PWM} = 4 kHz.



Motor Selection

Motor selection for asynchronous AC motors (VFC)

Examples for motor selection for delta/star AC 230/400 V

Trolley drive



Constant load with overload (acceleration) and low load during travel:

- $P_{\text{travel}} = 1.3 \text{ kW}$
- $P_{\text{max}} = 13 \text{ kW}$
- $n_{\text{min}} = 270 \text{ 1/min}$, setting range 1:10
- $n_{\text{max}} = 2610 \text{ 1/min}$

In inverter mode with adapted power ($P = P_n$), the motor can output 150 % of its listed power during the acceleration phase. The following applies:

$$P_{\text{Mot}} = P_{\text{max}} : 1.5 = 13 \text{ kW} : 1.5 = 8.67 \text{ kW}$$

A DV132M4 motor with delta connection ($P_n = 9.2 \text{ kW}$) is selected.

The selection table (→ page 101) allocates a MOVIDRIVE[®] compact MCF60A0110 ($P = P_n$).

Hoist drive



High constant load with short-term overload (acceleration):

- $P_{\text{max}} = 26 \text{ kW}$
- $P_{\text{const.}} = 20 \text{ kW}$
- Setting range 1:15, low speed only for positioning
- Brake applied when the drive is at a standstill
- Load type S3 (40 % cdf)

The inverter can yield 150 % of its rated current during acceleration. Consequently, a MOVIDRIVE[®] compact MCF60A0220 is selected.

In view of the load type (S3, 40 % cdf), the selection table allocates motor type DV180L4 ($P_n = 22 \text{ kW}$) in a star connection.

For further information → section "Project planning" in the MOVIDRIVE[®] compact system manual.

Fan/pump



Variable torque load with the following power values:

- $P_{\text{max}} = 4.8 \text{ kW}$
- $n_{\text{max}} = 1,400 \text{ 1/min}$, continuous duty with n_{max}

The motor can be operated at its listed power ($P = P_n$) even without forced cooling due to the quadratically falling torque. Therefore, the motor type DV132S4 in star connection ($P_n = 5.5 \text{ kW}$) is sufficient.

The selection table allocates a MOVIDRIVE[®] compact MCF60A0055 ($P = P_n$). However, as there is a variable torque load without overload, the inverter can be operated with increased output power. Consequently, a MOVIDRIVE[®] compact MCF60A0040 is sufficient.



Motor selection in connection type double-star/star (AC 230/460 V / 60 Hz)

P_{max} [kW] for operation on MOVIDRIVE® compact MCF/MCV/MCH 4_A...-5_3 (AC 400/500 V units)							
Connection		△ / AC 460 V			△△ / AC 230 V		
Cooling		Own	Own	Forced	Own	Forced	
f _{min} - f _{max} [Hz]		6 - 90	10 - 60	0 - 60 ¹⁾	10 - 120	0 - 120 ¹⁾	
n _{min} - n _{max} [1/min]		180 - 2700	200 - 1800	0 - 1800	200 - 3600	0 - 3600	
Setting range		1:15	1:6	≥ 1:15	1:12	≥ 1:20	
Motor type	Rated power P _n [kW]	P = P _{reduced}		P = P _n		P = P _{increased} ²⁾	
		[kW]	MCF/MCV/MCH ³⁾ 4_A...-5_3	[kW]	MCF/MCV/MCH ³⁾ 4_A...-5_3	[kW]	MCF/MCV/MCH ³⁾ 4_A...-5_3
DT71D4	0.37	0.25	0015	0.37	0015	0.75	0015
DT80K4	0.55	0.37		1.1			
DT80N4	0.75	0.55		1.5			
DT90S4	1.1	0.75		2.2			
DT90L4	1.5	1.1		3.0			
DV100M4	2.2	1.5		4.0			
DV100L4	3.7	2.2	0022	3.0	0030	5.5	0055
DV112M4	4.0	3.0	0030	4.0	0040	7.5	0075
DV132S4	5.5	4.0	0040	5.5	0055	9.2	0110
DV132M4	7.5	5.5	0055	7.5	0075	11	
DV132ML4	9.2	7.5	0075	9.2	0110	15	0150
DV160M4	11	9.2	0110	11		18.5	0220
DV160L4	15	11		15	0150	22	
DV180M4	18.5	15	0150	18.5	0220	30	0300
DV180L4	22	18.5	0220	22		37	0370
DV200L4	30	22		30	0300	45	0450
DV225S4	37	30	0300	37	0370	55	0550
DV225M4	45	37	0370	45	0450	75	0750
DV250M4	55	45	0450	55	0550		
DV280S4	75	55	0550	75	0750		
DV280M4	90	75	0750				

- 1) The following applies to MCF, MCV and MCH without speed control: f_{min} = 0.5 Hz
- 2) P_{increased} means that the motor is operated at the power of the next larger motor (one frame size), rather than with $\sqrt{3}$ -fold power.
- 3) The units listed here permit intermittent loads of up to 1.5 times the rated load in the specific application. With variable torque load and constant load without overload, each inverter can also be operated with increased continuous output power (→ Sec. Technical Data). The continuous output current of 125 % of the rated unit current is only available at f_{PWM} = 4 kHz.



Motor Selection

Motor selection for asynchronous AC motors (VFC)

Motor selection for delta connection (AC 230 V / 50 Hz)

P _{max} [kW] for operation on MOVIDRIVE® compact MCF/MCV/MCH 4_A...-2_3 (AC 230 V units)					
Connection		Δ / AC 230 V			
Cooling		Own		Forced	
f _{min} - f _{max} [Hz]		10 - 50 6 - 60 5 - 70 / 5.5 - 80		≤ 2.5 - 50 / ≤ 3 - 60 ¹⁾	
n _{min} - n _{max} [1/min]		300 - 1500 180 - 1800 150 - 2100 / 165 - 2400		≤ 75 - 1500 / ≤ 90 - 1800	
Setting range		1:5 1:10 1:15		≥ 1:20	
Motor type ²⁾	Rated power P _n [kW]	P = P _{reduced} MCF/MCV/MCH ³⁾ 4_A...-2_3		P = P _n MCF/MCV/MCH ³⁾ 4_A...-2_3	
		[kW]		[kW]	
DT71D4	0.37	0.25	0015	0.37	0015
DT80K4	0.55	0.37		0.55	
DT80N4	0.75	0.55		0.75	
DT90S4	1.1	0.75		1.1	
DT90L4	1.5	1.1		1.5	
DV100M4	2.2	1.5		2.2	
DV100L4	3.0	2.2	0022	3.0	0030
DV112M4	4.0	3.0	0030	4.0	0040
DV132S4	5.5	4.0	0040	5.5	0055
DV132M4	7.5	5.5	0055	7.5	0075
DV132ML4	9.2	7.5	0075	9.2	0110
DV160M4	11	9.2	0110	11	
DV160L4	15	11		15	0150
DV180M4	18.5	15	0150	18.5	0220
DV180L4	22	18.5	0220	22	0300
DV200L4	30	22		30	
DV225S4	37	30	0300		-

1) The following applies to MCF, MCV and MCH without speed control: f_{min} = 0.5 Hz

2) In load type S3 (40 % cdf), the motor can be operated at its listed power (P = P_n) without forced cooling. Example: P_{stat} = 2 kW, P_{dyn} = 2.5 kW → selected motor DV100M4 (P_n = 2.2 kW).

3) The units listed here permit intermittent loads of up to 1.5 times the rated load in the specific application. With variable torque load and constant load without overload, each inverter can also be operated with increased continuous output power (→ Sec. Technical Data). The continuous output current of 125 % of the rated unit current is only available at f_{PWM} = 4 kHz.



Motor selection for connection type double-star (AC 230 V / 60 Hz)

P _{max} [kW] for operation on MOVIDRIVE® compact MCF/MCV/MCH 4_A...-2_3 (AC 230 V units)				
Connection		/ AC 230 V		
Cooling		Own	Own	Forced
f _{min} - f _{max} [Hz]		6 - 90	10 - 60	0 - 60 ¹⁾
n _{min} - n _{max} [1/min]		180 - 2700	200 - 1800	0 - 1800
Setting range		1:15	1:6	≥ 1:15
Motor type	Rated power P _n [kW]	P = P _{reduced}		P = P _n
		[kW]	MCF/MCV/MCH ²⁾ 4_A...-2_3	[kW]
DT71D4	0.37	0.25	0015	0.37
DT80K4	0.55	0.37		0.55
DT80N4	0.75	0.55		0.75
DT90S4	1.1	0.75		1.1
DT90L4	1.5	1.1		1.5
DV100M4	2.2	1.5	0022	2.2
DV100L4	3.7	2.2		3.0
DV112M4	4.0	3.0	0030	4.0
DV132S4	5.5	4.0	0040	5.5
DV132M4	7.5	5.5	0055	7.5
DV132ML4	9.2	7.5	0075	9.2
DV160M4	11	9.2		11
DV160L4	15	11	0110	15
DV180M4	18.5	15	0150	18.5
DV180L4	22	18.5	0220	22
DV200L4	30	22		30
DV225S4	37	30	0300	-

- 1) The following applies to MCF, MCV and MCH without speed control: f_{min} = 0.5 Hz
- 2) The units listed here permit intermittent loads of up to 1.5 times the rated load in the specific application. With variable torque load and constant load without overload, each inverter can also be operated with increased continuous output power (→ Sec. Technical Data). The continuous output current of 125% of the rated unit current is only available at f_{PWM} = 4 kHz.



Motor Selection

Motor selection for asynchronous servomotors (CFC)

3.2 Motor selection for asynchronous servomotors (CFC)

Basic recommendations

Observe the following recommendations for selecting the motor:

- Only use motors with at least thermal class F.
- Use TF thermistors or TH winding thermostats.

NOTE	
	<p>The torque limit (M limit) is set automatically by the startup function of the MOVITOOLS® operating software. Do not increase this automatically set value!</p> <p>SEW-EURODRIVE recommends always using the latest version of MOVITOOLS® for startup. The latest MOVITOOLS® version can be downloaded from our homepage (www.sew-eurodrive.com).</p>

Motor characteristics

Drives in CFC operating modes are characterized by their ability to control torque directly and quickly. This means they achieve a highly dynamic overload capacity (up to $3 \times M_N$) and a very high speed and control range (up to 1:5000). Stable speed and positioning accuracy meet the high requirements of servo technology. These characteristics are made possible through field-oriented control. The current components for magnetization (I_d) and torque generation (I_q) are controlled separately. A prerequisite for the CFC operating modes is that the motor must always be equipped with an encoder.

The inverter needs to know exact data about the connected motor to calculate the motor model. This data is made available by the MOVITOOLS® operating software with the startup function. CFC operating modes are only possible with 4-pole SEW-motors (CT/CV or DT/DV), not with other SEW motors or non-SEW motors. For 4-pole SEW motors, the motor data required for the CFC operating modes is stored in MOVIDRIVE®.

Typical speed/torque characteristic curve

M_N is determined by the motor. M_{max} and n_{trans} depend on the motor/inverter combination. Refer to the motor selection tables for the CFC mode for the values of n_{trans} , M_N and M_{max} .

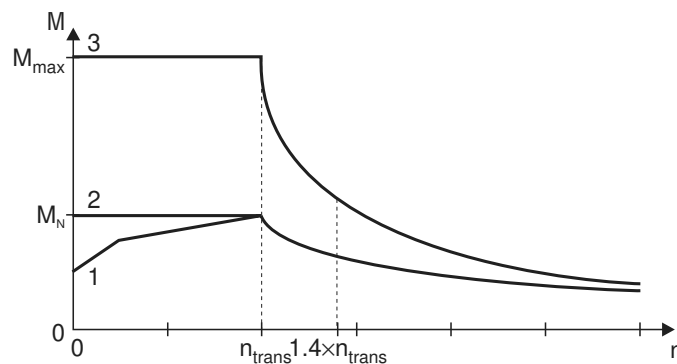

Figure 27: Speed/torque characteristic curve in CFC operating mode

01651BEN

- 1 With self-cooling
- 2 With forced cooling
- 3 Maximum torque



Magnetizing current

Dynamic drives that have to accelerate without a delay are also energized at standstill without load. The magnetizing current I_d flows at standstill. The inverter must be able to supply this current constantly in applications in which the output stage is permanently enabled, for example in CFC & M-CONTROL mode. In particular in the case of large motors with a slip frequency ≤ 2 Hz, you have to refer to the diagrams in the section "Overload capacity of the inverters" to check whether the inverter can supply the current. Also check whether the thermal characteristics of the motor are suitable (forced cooling fan) for this. For the magnetizing current I_d , refer to the motor tables (CT/CV → page 110, DT/DV → page 115).

CFC mode with speed control

There is no need to differentiate between the load types quadratic, dynamic and static when performing project planning for the CFC operating mode. Project planning for an asynchronous motor in CFC mode is carried out in accordance with the following requirements:

1. Effective torque requirement at average application speed.

$$M_{\text{eff}} < M_{N_Mot}$$

The operating point must lie below the characteristic curve for the continuous torque (Figure 27, curve 2). If this operating point lies below the characteristic curve for forced cooling (Figure 27, curve 1), then no forced cooling is required.

2. Maximum torque needed across the speed curve.

$$M_{\text{max}} < M_{\text{dyn_Mot}}$$

This operating point must lie below the characteristic curve for the maximum torque of the motor/MOVIDRIVE® combination (Figure 27, curve 3).

3. Maximum speed

Do not configure the maximum speed of the motor higher than 1.4 times the transition speed. The maximum torque available will then still be approximately 110 % of the continuous rated torque of the motor; also, the input speed for the gear unit connected to the motor output will still be less than 3,000 1/min with delta connection.

$$n_{\text{max}} < 1.4 \times n_{\text{trans}} < 3000 \text{ 1/min}$$

Cooling the motor

Self-cooling of asynchronous motors is based on the integrated fan, which means self-cooling depends on the speed. The integrated fan does not provide cooling for the motor at low speeds and standstill. Forced cooling may be necessary in case of a high static load or a high effective torque.



Motor Selection

Motor selection for asynchronous servomotors (CFC)

CFC operation with torque control (CFC & M-CONTROL)

This operating mode permits direct torque control of the asynchronous motor in the basic speed range ($n \leq n_{\text{trans}}$). The setpoint sources of the speed-controlled CFC mode can also be used for torque control. All speed setpoint sources (except for bus setpoints) are interpreted as current setpoint sources. Assign "Current" to a process data word for fieldbus control. The settings for evaluating the analog input (\rightarrow P11_, parameter description) also remain in effect. The fixed setpoints (P16_, P17_) can be entered in the units [1/min] or [%I_{N_inverter}] as required (\rightarrow MOVITOOLS®).

The following relationship exists between the units:

3000 1/min = 150 % rated inverter current

The torque on the output shaft of the motor can be calculated for the basic speed range ($n \leq n_{\text{trans}}$) using the following formulae:

Specification of a setpoint for the motor torque in %I_{N_inverter}:

$$M = k_T \times I_{n_inverter} \times \text{Setpoint}$$

04972AEN

Specification of a setpoint for the motor torque in 1/min:

$$M = k_T \times 1.5 \times I_{n_inverter} \times \frac{\text{Setpoint}}{3000 \text{ rpm}}$$

04973AEN

$I_{N_inverter}$ = Rated output current of the inverter

k_T = Torque constant = M_n / I_{q_n}

M_n and I_{q_n} are motor-specific values. For the values of the torque constants k_T and the motor-specific values M_n and I_{q_n} , refer to the motor tables (DT/DV \rightarrow page 115, CT/CV \rightarrow page 109).

In addition to the current I_q for creating the torque, the inverter also needs to supply the magnetizing current I_d . The actual inverter output current I_{tot} can be calculated using the following formulae:

Specification of a setpoint for the motor torque in %I_{N_inverter}:

$$I_{\text{tot}} = \sqrt{(\text{Setpoint} \times I_{n_inverter})^2 + I_{d_N}^2}$$

04974AEN

Specification of a setpoint for the motor torque in 1/min:

$$I_{\text{tot}} = \sqrt{\left(\text{Setpoint} \times 1.5 \times I_{n_inverter} \times \frac{1}{3000 \text{ rpm}}\right)^2 + I_{d_N}^2}$$

04975AEN

I_{q_n} = Nominal value of the torque-generating current according to the motor table

I_{d_n} = Nominal value of the magnetizing current according to the motor table



Asynchronous servomotors CT/CV

SEW-EURODRIVE offers CT/CV asynchronous servomotors specifically for operation with MOVIDRIVE® in the CFC operating modes. These motors have the following characteristics:

- High power yield* The optimum winding of CT/CV motors permits a high power yield.

- Division into speed classes* CT/CV motors are available in four speed classes. This division ensures optimum utilization of torque and speed.

- Sin/cos encoder as standard* CT/CV motors are equipped as standard with a high-resolution sin/cos encoder (ES1S, ES2S, EV1S).

- TF or TH motor protection as standard* The winding temperature of the three motor phases is monitored using thermistors (TF). The thermistor can be connected to the TF/TH input of MOVIDRIVE®. The temperature is then monitored by MOVIDRIVE®; no additional monitoring unit is required.
 Bimetallic switches (TH) can also be used instead of thermistors. The bimetallic switches are also connected to the TF/TH input.

- Thermal classification F as standard* CT/CV motors are designed with thermal classification F materials.

- Reinforced pinion shaft ends* CT/CV motors can generate up to three times their rated motor torque in dynamic operation. For this reason, these motors are equipped with reinforced pinion shaft ends for direct mounting to gear units to enable them to transmit the high torque levels reliably.

Either DT/DV/ motors or CT/CV motors can be used in CFC mode. SEW-EURODRIVE recommends using CT/CV motors to achieve optimum benefit from the CFC mode.

	Advantage	Disadvantage
CFC mode with DT/DV motor Motor selection → page 119	Standard motor version	Lower transition speed than the CT/CV motor.
		The power yield of the motor is less than the rated motor power.
		In terms of the power yield, the mass inertia is greater than that of the CT/CV motors.
		The maximum torque is limited for some of the inverter/motor combinations due to mechanical rigidity.
CFC mode with CT/CV motor Motor selection → page 111	Higher transition speed than DT/DV motor.	No IEC standard motor
	Usually with a power yield one motor type higher.	
	Based on the power yield of a lower mass moment of inertia.	Higher current demand due to higher power yield; therefore a larger inverter has to be assigned.
	Motor is designed for dynamic operation.	



Motor Selection

Motor selection for asynchronous servomotors (CFC)

CT/CV motor table

n_N [1/min]	Motor	M_N [Nm]	I_N [A]	$I_{q,n}$ [A]	$I_{d,n}$ [A]	k_T [Nm/A]	U_N [V]	J_{Mot} [10 ⁻⁴ kgm ²]	J_{BMot}
1200	CT71D4	3	1.4	1.21	0.69	2.48	360	4.6	5.5
	CT80N4	5	2.1	1.65	1.30	3.0	350	8.7	9.6
	CT90L4	10	3.65	3.13	1.89	3.2	345	34	39.5
	CV100M4	15	4.7	4.15	2.25	3.61	345	53	59
	CV100L4	26	8.5	7.9	3.21	3.29	320	65	71
	CV132S4	37	11.5	10.4	4.83	3.56	340	146	158
	CV132M4	50	15.5	14.2	6.18	3.52	340	280	324
	CV132ML4	61	18.2	16.7	7.43	3.66	345	330	374
	CV160M4	73	22.5	20.3	9.73	3.60	335	400	440
	CV160L4	95	30	26.7	14.2	3.56	330	925	1030
	CV180M4	110	36	30.2	19.7	3.65	330	1120	1226
	CV180L4	125	39.5	33.8	20.5	3.7	345	1290	1396
	CV200L4	200	58	53.2	23.7	3.76	330	2340	2475
1700	CT71D4	3	1.9	1.67	0.95	2.48	355	4.6	5.5
	CT80N4	5	2.9	2.28	1.79	3.03	350	8.7	9.6
	CT90L4	10	5	4.32	2.61	3.2	345	34	39.5
	CV100M4	15	6.5	5.73	3.10	3.61	345	53	59
	CV100L4	26	11.7	10.86	4.41	3.29	320	65	71
	CV132S4	37	15.8	14.35	6.67	3.56	340	146	158
	CV132M4	48	21	19.2	8.7	3.52	335	280	324
	CV132ML4	58	26.5	23.8	11.2	3.66	320	330	374
	CV160M4	71	30.5	27.2	13.4	3.6	340	400	440
	CV160L4	89	39.5	34.5	19.53	3.56	335	925	1030
	CV180M4	105	48	39.7	27.2	3.65	335	1120	1226
	CV180L4	115	56	46.6	30.7	3.7	325	1290	1396
	CV200L4	190	79	71.2	33.4	3.76	325	2340	2475
2100	CT71D4	3	2.4	2.1	1.20	1.43	345	4.6	5.5
	CT80N4	5	3.65	2.87	2.26	1.74	340	8.7	9.6
	CT90L4	10	6.4	5.44	3.29	1.84	335	34	39.5
	CV100M4	15	8.2	7.23	3.91	2.07	335	53	59
	CV100L4	25	14.3	13.2	5.56	1.9	310	65	71
	CV132S4	37	19.9	18.1	8.41	2.05	335	146	158
	CV132M4	48	26	23.7	10.75	2.03	330	280	324
	CV132ML4	58	30.5	27.5	12.9	2.1	340	330	374
	CV160M4	70	38	33.9	16.9	2.07	330	400	440
	CV160L4	88	49.5	43	24.6	2.05	330	925	1030
	CV180M4	100	59	47.7	34.2	2.1	325	1120	1226
	CV180L4	115	64	53.7	35.4	2.14	345	1290	1396
	CV200L4	175	91	80.1	41.2	2.16	325	2340	2475
3000	CT71D4	3	3.35	2.9	1.65	1.04	350	4.6	5.5
	CT80N4	4.5	4.75	3.6	3.11	1.26	345	8.7	9.6
	CT90L4	9.5	8.4	7.12	4.54	1.33	345	34	39.5
	CV100M4	15	11.3	9.95	5.39	1.51	345	53	59
	CV100L4	21	17	15.2	7.65	1.38	310	65	71
	CV132S4	35	26.5	23.6	11.6	1.49	340	146	158
	CV132M4	45	34.5	31.2	15.1	1.44	335	280	324
	CV132ML4	52	41.5	36.9	19.3	1.41	320	330	374
	CV160M4	64	48.5	42.6	23.3	1.50	340	400	440
	CV160L4	85	67	57.2	33.9	1.49	340	925	1030
	CV180M4	93	77	61.1	47.2	1.52	335	1120	1226
	CV180L4	110	94	77	53.1	1.43	325	1290	1396
	CV200L4	145	110	94.1	57.8	1.54	330	2340	2475



CT/CV motor selection

	<p>NOTE</p> <p>CT/CV motors in the 4 speed classes are designed for operation with AC 400/500 V units. If you plan to install AC 230 V units, please contact SEW-EURODRIVE.</p>
--	--

1. Rated speed $n_N = 1200$ 1/min:

Assignment table for **MOVIDRIVE® compact MCV/MCH4_A...-5_3** (sizes 1 ... 5):

Motor		MOVIDRIVE® compact MCV/MCH4_A...-5_3 (AC 400/500 V units) in CFC operating modes (P700)												
		0015	0022	00300	0040	0055	0075	0110	0150	0220	0300	0370	0450	0550
CT80N4	M_{max} [Nm]	16.0												
	n_{trans} [1/min]	550												
CT90L4	M_{max} [Nm]	18.0	26.0	31.0										
	n_{trans} [1/min]	928	781	678										
CV100M4	M_{max} [Nm]		29.0	37.0	45.0									
	n_{trans} [1/min]		883	781	678									
CV100L4	M_{max} [Nm]			33.0	46.0	61.0	75.0							
	n_{trans} [1/min]			1050	934	800	666							
CV132S4	M_{max} [Nm]					64.0	84.0	110						
	n_{trans} [1/min]					992	915	826						
CV132M4	M_{max} [Nm]						82.0	125	150					
	n_{trans} [1/min]						1010	877	806					
CV132ML4	M_{max} [Nm]							129	174	183				
	n_{trans} [1/min]							890	781	774				
CV160M4	M_{max} [Nm]							125	169	220				
	n_{trans} [1/min]							986	909	838				
CV160L4	M_{max} [Nm]								163	240	295			
	n_{trans} [1/min]								1045	954	922			
CV180M4	M_{max} [Nm]									240	320	360		
	n_{trans} [1/min]									1050	986	1005		
CV180L4	M_{max} [Nm]									245	325	360	360	
	n_{trans} [1/min]									960	909	947	1035	
CV200L4	M_{max} [Nm]										325	400	495	565
	n_{trans} [1/min]										1010	986	947	941



Motor Selection

Motor selection for asynchronous servomotors (CFC)

2. Rated speed $n_N = 1700$ 1/min:

Assignment table for **MOVIDRIVE® compact MCV/MCH4_A...-5_3** (sizes 1 ... 5):

Motor		MOVIDRIVE® compact MCV/MCH4_A...-5_3 (AC 400/500 V units) in CFC operating modes (P700)													
		0015	0022	0030	0040	0055	0075	0110	0150	0220	0300	0370	0450	0550	0750
CT80N4	M_{max} [Nm]	13.0	16.0												
	n_{trans} [1/min]	1150	992												
CT90L4	M_{max} [Nm]		18.0	24.0	31.0										
	n_{trans} [1/min]		1400	1285	1150										
CV100M4	M_{max} [Nm]			26.0	36.0	45.0									
	n_{trans} [1/min]			1365	1230	1145									
CV100L4	M_{max} [Nm]				32.0	44.0	57.0	75.0							
	n_{trans} [1/min]				1535	1425	1300	1115							
CV132S4	M_{max} [Nm]						60.0	91.0	110						
	n_{trans} [1/min]						1470	1330	1295						
CV132M4	M_{max} [Nm]							87.4	118	150					
	n_{trans} [1/min]							1484	1370	1295					
CV132ML4	M_{max} [Nm]							83.0	114	166	183				
	n_{trans} [1/min]							1560	1485	1330	1345				
CV160M4	M_{max} [Nm]								120	176	220				
	n_{trans} [1/min]								1420	1310	1255				
CV160L4	M_{max} [Nm]									171	225	280	295		
	n_{trans} [1/min]									1470	1400	1330	1395		
CV180M4	M_{max} [Nm]									168	225	280	345	360	
	n_{trans} [1/min]									1555	1510	1460	1400	1505	
CV180L4	M_{max} [Nm]										210	260	320	360	360
	n_{trans} [1/min]										1510	1480	1435	1470	1665
CV200L4	M_{max} [Nm]												345	410	515
	n_{trans} [1/min]												1460	1425	1380



3. Rated speed $n_N = 2100$ 1/min:

Assignment table for **MOVIDRIVE® compact MCV/MCH4_A...5_3** (sizes 1 ... 5):

Motor		MOVIDRIVE® compact MCV/MCH4_A...5_3 (AC 400/500 V units) in CFC operating modes (P700)													
		0015	0022	0030	0040	0055	0075	0110	0150	0220	0300	0370	0450	0550	0750
CT71D4	M_{max} [Nm]	7.7													
	n_{trans} [1/min]	1320													
CT80N4	M_{max} [Nm]	9.7	14	16											
	n_{trans} [1/min]	1755	1510	1420											
CT90L4	M_{max} [Nm]			18	26	31									
	n_{trans} [1/min]			1845	1675	1620									
CV100M4	M_{max} [Nm]				28	38	45								
	n_{trans} [1/min]				1760	1625	1580								
CV100L4	M_{max} [Nm]					34	44	68	75.0						
	n_{trans} [1/min]					1980	1870	1615	1555						
CV132S4	M_{max} [Nm]							72	97	110					
	n_{trans} [1/min]							1850	1720	1785					
CV132M4	M_{max} [Nm]								95	138	150				
	n_{trans} [1/min]								1850	1670	1695				
CV132ML4	M_{max} [Nm]								97	143	183				
	n_{trans} [1/min]								1790	1660	1550				
CV160M4	M_{max} [Nm]									138	183	220			
	n_{trans} [1/min]									1790	1690	1625			
CV160L4	M_{max} [Nm]										177	220	270	295	
	n_{trans} [1/min]										1880	1825	1740	1780	
CV180M4	M_{max} [Nm]											220	270	320	360
	n_{trans} [1/min]											1940	1895	1835	1935
CV180L4	M_{max} [Nm]												275	330	360
	n_{trans} [1/min]												1710	1670	1805
CV200L4	M_{max} [Nm]													330	410
	n_{trans} [1/min]													1830	1790



Motor Selection

Motor selection for asynchronous servomotors (CFC)

4. Rated speed $n_N = 3000$ 1/min:

Assignment table for **MOVIDRIVE® compact MCV/MCH4_A...-5_3** (sizes 1 ... 5):

Motor		MOVIDRIVE® compact MCV/MCH4_A...-5_3 (AC 400/500 V units) in CFC operating modes (P700)													
		0015	0022	0030	0040	0055	0075	0110	0150	0220	0300	0370	0450	0550	0750
CT71D4	M_{max} [Nm]	6	7.7												
	n_{trans} [1/min]	2380	2095												
CT80N4	M_{max} [Nm]		9.7	13	16										
	n_{trans} [1/min]		2565	2360	2200										
CT90L4	M_{max} [Nm]				18	24	31								
	n_{trans} [1/min]				2660	2495	2370								
CV100M4	M_{max} [Nm]					27	35	45							
	n_{trans} [1/min]					2555	2430	2460							
CV100L4	M_{max} [Nm]						31	49	65	75					
	n_{trans} [1/min]						2850	2645	2425	2370					
CV132S4	M_{max} [Nm]							51	69	101	110				
	n_{trans} [1/min]							2745	2650	2460	2610				
CV132M4	M_{max} [Nm]								66	97	101	110			
	n_{trans} [1/min]								2810	2670	2515	2450			
CV132ML4	M_{max} [Nm]									94	124	152	183		
	n_{trans} [1/min]									2765	2655	2545	2445		
CV160M4	M_{max} [Nm]									98	131	161	197	220	
	n_{trans} [1/min]									2630	2555	2470	2370	2385	
CV160L4	M_{max} [Nm]											155	192	230	285
	n_{trans} [1/min]											2680	2620	2555	2440
CV180M4	M_{max} [Nm]												190	230	290
	n_{trans} [1/min]												2750	2705	2635
CV180L4	M_{max} [Nm]													210	270
	n_{trans} [1/min]													2680	2630
CV200L4	M_{max} [Nm]														285
	n_{trans} [1/min]														2625



Motor tables DT/DV

Characteristic values for delta/star AC 230/400 V / 50 Hz

Motor	M_N [Nm]	Mass moment of inertia J_M [10 ⁻⁴ kgm ²]		Star \star (AC 400 V)				Delta Δ (AC 230 V)			
		without brake	with brake	I_n [A]	$I_{q_n}^{1)}$ [A]	$I_{d_n}^{1)}$ [A]	$k_T^{1)}$ [Nm/A]	I_n [A]	$I_{q_n}^{1)}$ [A]	$I_{d_n}^{1)}$ [A]	$k_T^{1)}$ [Nm/A]
DT71D4	2.6	4.6	5.5	1.15	0.95	0.65	2.69	1.99	1.64	1.13	1.56
DT80K4	3.9	6.6	7.5	1.75	1.44	1	2.68	3.03	2.49	1.73	1.55
DT80N4	5.2	8.7	9.6	2.1	1.67	1.27	3.11	3.64	2.89	2.2	1.79
DT90S4	7.5	25	31	2.80	2.39	1.46	3.13	4.85	4.14	2.53	1.81
DT90L4	10.2	34	40	3.55	2.93	2	3.48	6.15	5.07	3.46	2.01
DV100M4	15.0	53	59	4.7	4.12	2.24	3.61	8.14	7.14	3.88	2.09
DV100L4	20.5	65	71	6.3	5.6	2.98	3.66	10.91	9.70	5	2.11
DV112M4	26.9	98	110	8.7	7.85	3.75	3.43	15.1	13.6	6.5	1.98
DV132S4	36.7	146	158	11	9.9	4.7	3.69	19.1	17.2	8.14	2.13
DV132M4	50.1	280	330	15.5	14.2	6.15	3.53	26.9	24.6	10.65	2.04
DV132ML4	61.0	330	380	18.1	16.5	7.46	3.7	31.35	28.6	12.9	2.13
DV160M4	72.9	398	448	22.5	20.3	9.70	3.59	39.0	35.2	16.8	2.07
DV160L4	98.1	925	1060	29.5	26.1	13.7	3.75	51.1	45.28	23.7	2.17
DV180M4	121	1120	1255/1350 ²⁾	37	21.7	19.1	3.82	64.1	54.9	33.1	2.2
DV180L4	143	1290	1425/1520 ¹⁾	42.5	37.4	20.3	3.83	73.6	64.71	35.1	2.21
DV200L4	195	2340	2475/2570 ²⁾	55	49.9	23.1	3.91	95.3	86.5	39.9	2.25
DV225S4	240	3010	3145/3240 ²⁾	67	61.6	26.4	3.9	116	106.7	45.7	2.25
DV225M4	292	3570	3705/3800 ²⁾	83	74.8	36.1	3.9	143.8	129.5	62.4	2.26
DV250M4	356	6300	6600/6730 ²⁾	102	91.7	44.7	3.88	176.7	158.8	77.4	2.24
DV280S4	484	8925	9225/9355 ²⁾	138	120.4	67.5	4.02	239	208.5	116.8	2.32
DV280M4	581	8925	9225/9355 ²⁾	170	148.9	68.9	3.9	294.5	257.9	119.3	2.25

- 1) Applies in the basic speed range up to n_{trans} .
- 2) Double disc brake



Motor Selection

Motor selection for asynchronous servomotors (CFC)

Characteristic values for double-star/star AC 230/460 V / 60 Hz

(according to MG1, NEMA Design B to DT80K4, NEMA Design C from DT80N4)

Motor	M_N [Nm]	Mass moment of inertia J_M		Star (AC 460 V)				Double-star (AC 230 V)			
		without brake	with brake	I_n [A]	$I_{q_n^{(1)}}$ [A]	$I_{d_n^{(1)}}$ [A]	$k_T^{(1)}$ [Nm/A]	I_n [A]	$I_{q_n^{(1)}}$ [A]	$I_{d_n^{(1)}}$ [A]	$k_T^{(1)}$ [Nm/A]
DT71D4	2.1	4.6	5.5	1	0.76	0.65	2.74	2	1.52	1.30	1.37
DT80K4	3.1	6.6	7.5	1.45	1.06	0.98	2.92	2.9	2.12	1.96	1.46
DT80N4	4.2	8.7	9.6	1.85	1.39	1.21	3.03	3.7	2.78	2.42	1.51
DT90S4	6.1	25	31	2.6	1.87	1.79	3.25	5.2	3.74	3.58	1.62
DT90L4	8.3	34	40	3.1	2.49	1.84	3.34	6.2	4.98	3.68	1.67
DT100M4	12.1	53	59	4.1	3.59	1.97	3.37	8.2	7.18	3.94	1.69
DT100L4	21	65	71	6.6	5.98	2.78	3.51	13.2	11.96	5.56	1.76
DV112M4	22.1	98	110	7	6.13	3.37	3.61	14	12.26	6.74	1.80
DV132S4	30.5	146	158	9.4	8.61	3.76	3.54	18.8	17.22	7.52	1.77
DV132M4	41.2	280	330	13.7	11.85	6.87	3.48	27.4	23.7	13.74	1.74
DV132ML4	50.5	330	380	16.4	14.41	7.83	3.50	32.8	28.82	15.66	1.75
DV160M4	60.4	398	448	20	17.36	9.92	3.48	40	34.72	19.84	1.74
DV160L4	81.4	925	1060	27	23.24	13.73	3.50	54	46.48	27.46	1.75
DV180M4	100	1120	1255/1350 ²⁾	31.5	28.06	14.29	3.56	63	56.1	28.58	1.78
DV180L4	119	1290	1425/1520 ²⁾	40	34.5	20.22	3.45	80	69	40.44	1.72
DV200L4	163	2340	2475/2570 ²⁾	47.5	44.63	16.25	3.65	95	89.26	32.5	1.83
DV225S4	201	3010	3145/3240 ²⁾	59	55.14	21	3.65	118	110.3	42	1.82
DV225M4	244	3570	3705/3800 ²⁾	70	64.6	27	3.78	140	129.2	54	1.89
DV250M4	296	6300	6600/6730 ²⁾	87	78.45	37.6	3.77	174	156.9	75.2	1.89
DV280S4	402	8925	9225/9355 ²⁾	118	106.5	50.8	3.77	236	213	101.6	1.89
DV280M4	580	14500	³⁾	162	153	51.7	3.79	324	306	103.4	1.89

1) Applies in the basic speed range up to n_{trans} .

2) Double disc brake

3) On request



DT/DV motor selection in connection type delta/star (AC 230/400 V / 50 Hz)

1. Star connection Δ 400 V / 50 Hz or AC 400/690 V / 50 Hz motors in Δ connection:

Motor		MOVIDRIVE® compact MCV/MCH4_A...-5_3 (AC 400/500 V units) in CFC operating modes													
Δ AC 400 V / 50 Hz		0015	0022	0030	0040	0055	0075	0110	0150	0220	0300	0370	0450	0550	0750
DT80N4	M _{max} [Nm]	9.3													
	n _{trans} [1/min]	922													
DT90S4	M _{max} [Nm]	13.5													
	n _{trans} [1/min]	1011													
DT90L4	M _{max} [Nm]	18.3	18.3												
	n _{trans} [1/min]	973	1088												
DV100M4	M _{max} [Nm]		26.8	26.8	26.8										
	n _{trans} [1/min]		941	1043	1056										
DV100L4	M _{max} [Nm]			36.8	36.8	36.8									
	n _{trans} [1/min]			890	1005	1011									
DV112M4	M _{max} [Nm]				47.1	48.4	48.4								
	n _{trans} [1/min]				915	1030	1062								
DV132S4	M _{max} [Nm]					66.1	66.1	66.1							
	n _{trans} [1/min]					1011	1171	1222							
DV132M4	M _{max} [Nm]						81.7	90.2	90.2						
	n _{trans} [1/min]						1011	1145	1152						
DV132ML4	M _{max} [Nm]							110	110						
	n _{trans} [1/min]							1082	1165						
DV160M4	M _{max} [Nm]							125	131	131					
	n _{trans} [1/min]							986	1133	1197					
DV160L4	M _{max} [Nm]								172	177	177				
	n _{trans} [1/min]								1050	1306	1350				
DV180M4	M _{max} [Nm]									217	217	217			
	n _{trans} [1/min]									1222	1453	1517			
DV180L4	M _{max} [Nm]									231.2	258	258	258		
	n _{trans} [1/min]									1018	1152	1299	1370		
DV200L4	M _{max} [Nm]										339.5	351	351	351	
	n _{trans} [1/min]										1018	1171	1350	1466	
DV225S4	M _{max} [Nm]											414.7	433	433	433
	n _{trans} [1/min]											954	1082	1222	1363
DV225M4	M _{max} [Nm]												502.6	526	526
	n _{trans} [1/min]												1037	1146	1344
DV250M4	M _{max} [Nm]													586.5	641
	n _{trans} [1/min]													1018	1133
DV280S4	M _{max} [Nm]														735.4
	n _{trans} [1/min]														1082

Note: The maximum torque M_{max} is limited to 180 % of the rated motor torque M_N. The data is based on a supply voltage of AC 400 V.



Motor Selection

Motor selection for asynchronous servomotors (CFC)

2. Motor AC 230/400 V / 50 Hz in delta connection:

Assignment table for MOVIDRIVE® compact MCV/MCH4_A...-5_3 (sizes 1 ... 5):

Motor		MOVIDRIVE® compact MCV/MCH4_A...-5_3 (AC 400/500 V units) in CFC operating modes													
Δ AC 230 V / 50 Hz		0015	0022	0030	0040	0055	0075	0110	0150	0220	0300	0370	0450	0550	0750
DT71D4	M _{max} [Nm]	4.6													
	n _{trans} [1/min]	2054													
DT80K4	M _{max} [Nm]	6.9	6.9												
	n _{trans} [1/min]	1850	1869												
DT80N4	M _{max} [Nm]	9.3	9.3												
	n _{trans} [1/min]	1869	2080												
DT90S4	M _{max} [Nm]		13.5	13.5	13.5										
	n _{trans} [1/min]		1971	2246	2304										
DT90L4	M _{max} [Nm]			18.3	18.3	18.3									
	n _{trans} [1/min]			1946	2342	2387									
DV100M4	M _{max} [Nm]				26.8	26.8	26.8								
	n _{trans} [1/min]				1862	2214	2298								
DV100L4	M _{max} [Nm]					36.8	36.8	36.8							
	n _{trans} [1/min]					1779	2080	2188							
DV112M4	M _{max} [Nm]						45.5	48.4	48.4						
	n _{trans} [1/min]						1779	2163	2195						
DV132S4	M _{max} [Nm]							66.1	66.1	66.1					
	n _{trans} [1/min]							2086	2458	2496					
DV132M4	M _{max} [Nm]								90.2	90.2					
	n _{trans} [1/min]								1939	2310					
DV132ML4	M _{max} [Nm]									110	110				
	n _{trans} [1/min]									2176	2291				
DV160M4	M _{max} [Nm]									131	131	131			
	n _{trans} [1/min]									1894	2246	2348			
DV160L4	M _{max} [Nm]										177	177	177		
	n _{trans} [1/min]										2010	2336	2560		
DV180M4	M _{max} [Nm]											217	217	217	
	n _{trans} [1/min]											2061	2445	2720	
DV180L4	M _{max} [Nm]												258	258	258
	n _{trans} [1/min]												1837	2131	2458
DV200L4	M _{max} [Nm]													341.8	351
	n _{trans} [1/min]													1843	2182
DV225S4	M _{max} [Nm]														425
	n _{trans} [1/min]														1715

Note: The maximum torque M_{max} is limited to 180 % of the rated motor torque M_N. The data is based on a supply voltage of AC 400 V.



DT/DV motor selection in double-star/star connection type (AC 230/460 V / 60 Hz)

Assignment table for **MOVIDRIVE® compact MCV/MCH4_A...-5_3** (sizes 1 ... 5):

Motor		MOVIDRIVE® compact MCV/MCH4_A...-5_3 (AC 400/500 V units) in CFC operating modes													
AC 460 V / 60 Hz		0015	0022	0030	0040	0055	0075	0110	0150	0220	0300	0370	0450	0550	0750
DT80N4	M _{max} [Nm]	9.3													
	n _{trans} [1/min]	1146													
DT90S4	M _{max} [Nm]	13.5													
	n _{trans} [1/min]	1312													
DT90L4	M _{max} [Nm]	18.3	18.3												
	n _{trans} [1/min]	1152	1318												
DV100M4	M _{max} [Nm]		26.8	26.8											
	n _{trans} [1/min]		1363	1510											
DV100L4	M _{max} [Nm]			35.6	36.8	36.8									
	n _{trans} [1/min]			1069	1197	1210									
DV112M4	M _{max} [Nm]			35.8	48.4	48.4									
	n _{trans} [1/min]			1197	1139	1312									
DV132S4	M _{max} [Nm]				48.7	65	66								
	n _{trans} [1/min]				1069	992	1101								
DV132M4	M _{max} [Nm]					60.8	80	90							
	n _{trans} [1/min]					1152	1088	1222							
DV132ML4	M _{max} [Nm]							110	110						
	n _{trans} [1/min]							1171	1267						
DV160M4	M _{max} [Nm]							120	131	131					
	n _{trans} [1/min]							1133	1261	1319					
DV160L4	M _{max} [Nm]								161	177					
	n _{trans} [1/min]								1158	1370					
DV180M4	M _{max} [Nm]								164	217	217				
	n _{trans} [1/min]								1139	1177	1350				
DV180L4	M _{max} [Nm]									228	258	258			
	n _{trans} [1/min]									1082	1197	1325			
DV200L4	M _{max} [Nm]										323	351	351		
	n _{trans} [1/min]										1024	1107	1248		
DV225S4	M _{max} [Nm]										318	391	433	433	
	n _{trans} [1/min]										1101	1075	1146	1286	
DV225M4	M _{max} [Nm]											401	494	526	526
	n _{trans} [1/min]											1082	1056	1139	1325
DV250M4	M _{max} [Nm]													576	641
	n _{trans} [1/min]													1261	1370
DV280S4	M _{max} [Nm]														711
	n _{trans} [1/min]														1421
DV280M4	M _{max} [Nm]														712
	n _{trans} [1/min]														1338

Note: The maximum torque M_{max} is limited to 180 % of the rated motor torque M_N. The data is based on a supply voltage of AC 400 V.



Motor Selection

Motor selection for asynchronous servomotors (CFC)

2. Motors AC 230/460 V / 60 Hz in double-star connection:

Assignment table for MOVIDRIVE® compact MCV/MCH4_A...-5_3 (sizes 1 ... 5):

Motor		MOVIDRIVE® compact MCV/MCH4_A...-5_3 (AC 400/500 V units) in CFC operating modes													
AC 230 V / 60 Hz		0015	0022	0030	0040	0055	0075	0110	0150	0220	0300	0370	0450	0550	0750
DT71D4	M _{max} [Nm]	4.6													
	n _{trans} [1/min]	2989													
DT80K4	M _{max} [Nm]	7	7												
	n _{trans} [1/min]	2688	2822												
DT80N4	M _{max} [Nm]	8.3	9.3	9.3											
	n _{trans} [1/min]	2586	2874	2970											
DT90S4	M _{max} [Nm]		11.9	13.5	13.5										
	n _{trans} [1/min]		2637	2931	3462										
DT90L4	M _{max} [Nm]			16.4	18.3	18.3									
	n _{trans} [1/min]			2605	3014	3354									
DV100M4	M _{max} [Nm]				23.1	26	26.8								
	n _{trans} [1/min]				3142	3360	3680								
DV100L4	M _{max} [Nm]					31.5	36.8	36.8							
	n _{trans} [1/min]					2470	2605	3014							
DV112M4	M _{max} [Nm]						41.4	48.4							
	n _{trans} [1/min]						2534	2989							
DV132S4	M _{max} [Nm]							62.4	66						
	n _{trans} [1/min]							2234	2573						
DV132M4	M _{max} [Nm]								80	90.2					
	n _{trans} [1/min]								2349	2707					
DV132ML4	M _{max} [Nm]									110	110				
	n _{trans} [1/min]									2496	2880				
DV160M4	M _{max} [Nm]									115	131	131			
	n _{trans} [1/min]									2451	2688	2963			
DV160L4	M _{max} [Nm]										150	177	177		
	n _{trans} [1/min]										2458	2515	2918		
DV180M4	M _{max} [Nm]											189	217	217	
	n _{trans} [1/min]											2355	2458	2771	
DV180L4	M _{max} [Nm]												220	258	258
	n _{trans} [1/min]												2285	2291	2720
DV200L4	M _{max} [Nm]													281	350
	n _{trans} [1/min]													2208	2163
DV225S4	M _{max} [Nm]														346
	n _{trans} [1/min]														2291
DV225M4	M _{max} [Nm]														354
	n _{trans} [1/min]														2278

Note: The maximum torque M_{max} is limited to 180 % of the rated motor torque M_N. The data is based on a supply voltage of AC 400 V.



DT/DV motor selection in connection type delta (AC 230 V / 50 Hz)

Motor		MOVIDRIVE® compact MCV/MCH4_A...-2_3 (AC 230 V units) in CFC operating modes (P700)								
Δ AC 230 V / 50 Hz		0015	0022	0037	0055	0075	0110	0150	0220	0300
DT80K4	M _{max} [Nm]	6.9								
	n _{trans} [1/min]	813								
DT80N4	M _{max} [Nm]	9.3								
	n _{trans} [1/min]	922								
DT90S4	M _{max} [Nm]	13.5	13.5							
	n _{trans} [1/min]	1011	1011							
DT90L4	M _{max} [Nm]	18.3	18.3	18.3						
	n _{trans} [1/min]	998	1068	1088						
DV100M4	M _{max} [Nm]		25.5	26.8						
	n _{trans} [1/min]		922	1056						
DV100L4	M _{max} [Nm]			36.8	36.8					
	n _{trans} [1/min]			973	1011					
DV112M4	M _{max} [Nm]				48.4	48.4				
	n _{trans} [1/min]				1037	1062				
DV132S4	M _{max} [Nm]				66.1	66.1	66.1			
	n _{trans} [1/min]				1024	1190	1222			
DV132M4	M _{max} [Nm]					85.4	90.2	90.2		
	n _{trans} [1/min]					998	1152	1152		
DV132ML4	M _{max} [Nm]						110	110	110	
	n _{trans} [1/min]						1082	1165	1165	
DV160M4	M _{max} [Nm]						126	131	131	
	n _{trans} [1/min]						979	1120	1197	
DV160L4	M _{max} [Nm]							167	177	177
	n _{trans} [1/min]							1056	1306	1350
DV180M4	M _{max} [Nm]								217	217
	n _{trans} [1/min]								1222	1382
DV180L4	M _{max} [Nm]								231	258
	n _{trans} [1/min]								1017	1069
DV200L4	M _{max} [Nm]									307
	n _{trans} [1/min]									1030

Note: The maximum torque M_{max} is limited to 180 % of the rated motor torque M_N. The data is based on a supply voltage of AC 230 V.



Motor Selection

Motor selection for asynchronous servomotors (CFC)

DT/DV motor selection in connection type double-star (AC 230 V / 60 Hz)

Motors AC 230/460 V / 60 Hz in double-star connection:

Motor		MOVIDRIVE® compact MCV/MCH4_A...-2_3 (AC 230 V units) in CFC operating modes (P700)								
AC 230 V / 60 Hz		0015	0022	0037	0055	0075	0110	0150	0220	0300
DT80N4	M _{max} [Nm]	9.3								
	n _{trans} [1/min]	1146								
DT90S4	M _{max} [Nm]	13.5	13.5							
	n _{trans} [1/min]	1267	1338							
DT90L4	M _{max} [Nm]	17.2	18.3	18.3						
	n _{trans} [1/min]	1146	1210	1325						
DV100M4	M _{max} [Nm]		20.7	26.8						
	n _{trans} [1/min]		1459	1517						
DV100L4	M _{max} [Nm]			36.8	36.8					
	n _{trans} [1/min]			1056	1210					
DV112M4	M _{max} [Nm]			37.2	48.4	48.4				
	n _{trans} [1/min]			1190	1248	1338				
DV132S4	M _{max} [Nm]				57	66.1	66.1			
	n _{trans} [1/min]				1030	1062	1120			
DV132M4	M _{max} [Nm]					71.7	90.2	90.2		
	n _{trans} [1/min]					1114	1165	1222		
DV132ML4	M _{max} [Nm]						106	110		
	n _{trans} [1/min]						1101	1235		
DV160M4	M _{max} [Nm]						104	131	131	
	n _{trans} [1/min]						1165	1146	1318	
DV160L4	M _{max} [Nm]							133	177	177
	n _{trans} [1/min]							1190	1267	1395
DV180M4	M _{max} [Nm]								208	217
	n _{trans} [1/min]								1101	1203
DV180L4	M _{max} [Nm]								195	236
	n _{trans} [1/min]								1107	1075
DV200L4	M _{max} [Nm]								210	253
	n _{trans} [1/min]								1082	1062
DV225S4	M _{max} [Nm]									247
	n _{trans} [1/min]									1133

Note: The maximum torque M_{max} is limited to 180 % of the rated motor torque M_N. The data is based on a supply voltage of AC 230 V.



3.3 Motor Selection for Synchronous Servomotors (SERVO)

	NOTE
	<p>The torque limit (M limit) is set automatically by the startup function of the MOVITOOLS® operating software. Do not increase this automatically set value!</p> <p>We recommend always using the latest version of MOVITOOLS® for startup. The latest MOVITOOLS® version can be downloaded from our homepage (www.sew-euro-drive.de).</p>

Motor characteristics

The demands made on a servo drive include speed dynamics, stable speed and positioning accuracy. CM/DS motors with MOVIDRIVE® meet these requirements.

Technically speaking, these are synchronous motors with permanent magnets on the rotor and a mounted resolver. The required characteristics, namely constant torque over a wide speed range (up to 5500 1/min), a high speed and control range (up to 1:3000) and a high overload capacity (more than $3 \times M_0$), are achieved using control by MOVIDRIVE®. The mass moment of inertia of the servomotor is lower than that of the asynchronous motor. This means it is ideally suited to applications requiring dynamic speeds.

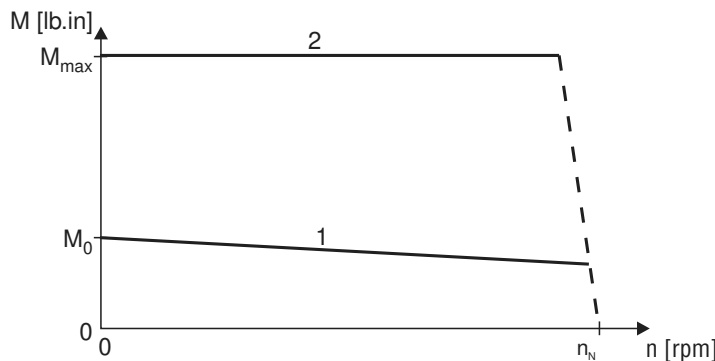

Figure 28: Speed/torque characteristic curve of the CM/DS servomotor

01652CEN

- 1 Continuous torque
- 2 Maximum torque

M_0 and M_{max} are determined by the motor. The attainable M_{max} can also be less, depending on the inverter.

Refer to the DS/CM motor tables for the values for M_0 .

Refer to the DS/CM motor selection tables for the values for M_{max} .



Motor Selection

Motor Selection for Synchronous Servomotors (SERVO)

Basic recommendations

For the SEW motors, the motor data required for the SERVO operating modes is stored in MOVIDRIVE®.

Speed is the correcting variable in the SERVO operating modes with speed control. Torque is the correcting variable in the SERVO operating modes with torque control (SERVO & M-CONTROL).

SERVO mode with speed control

There is no need to differentiate between the load types quadratic, dynamic and static when performing project planning for the SERVO operating mode. Project planning for a synchronous motor is carried out in accordance with the following requirements:

1. Effective torque requirement at average application speed.

$$M_{\text{eff}} < M_0$$

The operating point must lie below the characteristic curve for the continuous torque (Figure 28, curve 1). If this operating point lies above the characteristic curve for self-cooling, the continuous torque of the DFY series can be increased by 60 % by forced cooling.

2. Maximum torque needed across the speed curve.

$$M_{\text{max}} < M_{\text{dyn_Mot}}$$

This operating point must lie below the characteristic curve for the maximum torque of the motor/MOVIDRIVE® combination (Figure 28, curve 2).

3. Maximum speed

The maximum speed must not be configured higher than the rated speed of the motor. Planetary gear units should be used for speeds greater than 3000 1/min due to the high input speed.

$$n_{\text{max}} \leq n_N$$

SERVO operation with torque control (SERVO & M-CTRL)

This operating mode allows the servomotor to be controlled directly with torque control. The setpoint sources of the speed-controlled SERVO mode can also be used for torque control. All speed setpoint sources (except for bus setpoints) are interpreted as current setpoint sources. The settings for evaluating the analog input (→ P11_, parameter description) also remain in effect. The fixed setpoints (P16_, P17_) can be entered in the units [1/min] or [%I_{N_inverter}] as required (→ MOVITOOLS®).

The following relationship exists between the units:

$$3000 \text{ 1/min} = 150 \% \text{ rated inverter current}$$

The torque at the output shaft of the servomotor can be calculated using the following formula:

$$M = \frac{M_0}{I_0} \times \frac{150 \% \times I_{n_inverter} \times n_{\text{setp}}}{3000 \text{ 1/min}}$$

04976AEN

M_0 Continuous static torque according to the motor table DS/CM

I_0 Continuous static current according to motor table DS/CM



DS/CM motor table

Characteristic values at $V_{max} = AC 230 V / AC 400 V$

n_N [1/min]	Motor	Without forced cooling fan			With forced cooling fan VR			$I_{max}^{1)}$ [A]	$I_{max}^{2)}$ [A]	Mass moment of inertia J_M	
		M_0 [Nm]	$I_0^{1)}$ [A]	$I_0^{2)}$ [A]	M_{0_VR} [Nm]	$I_{0_VR}^{1)}$ [A]	$I_{0_VR}^{2)}$ [A]			without brake [10 ⁻⁴ kgm ²]	with brake
2000	CM71S	5.0	2.2	3.95	7.3	3.2	5.7	8.8	15.8	4.85	6.89
	CM71M	6.5	3.0	5.3	9.4	4.2	7.7	12.0	21.0	6.27	8.31
	CM71L	9.5	4.2	7.4	13.8	6.1	10.7	16.8	29.5	9.1	11.1
	CM90S	11.0	4.9	8.7	16.0	7.1	12.6	19.6	35.0	14.3	19.8
	CM90M	14.5	6.9	12.1	21.0	10.0	17.5	28.0	48.5	18.6	24.1
	CM90L	21.0	9.9	17.1	30.5	14.4	25.0	40.0	68.0	27.1	32.6
	CM112S	23.5	10.0	18.0	34.0	14.5	26.0	40.0	72	67.4	87.5
	CM112M	31.0	13.5	24.5	45.0	19.6	35.5	54.0	98	87.4	108
	CM112L	45.0	20.0	35.5	65.0	29.0	51.0	80.0	142	128	148
	CM112H	68.0	30.5	52.0	95.0	42.5	73.0	122	208	189	209
3000	DS56M	1.0	1.65	1.65	-	-	-	6.6	6.6	0.47	0.85
	DS56L	2.0	2.4	2.4	-	-	-	9.6	9.6	0.82	1.2
	DS56H	4.0	2.8	4.7	-	-	-	11.2	19	1.53	1.88
	CM71S	5.0	3.3	5.9	7.3	4.8	8.6	13.2	23.5	4.85	6.89
	CM71M	6.5	4.3	7.6	9.4	6.2	11.0	17.2	30.5	6.27	8.31
	CM71L	9.5	6.2	11.1	13.8	9.0	16.1	25.0	44.5	9.1	11.1
	CM90S	11.0	7.3	12.7	16.0	10.6	18.4	30.0	51	14.3	19.8
	CM90M	14.5	10.1	17.4	21.0	14.6	25.0	40.0	70	18.6	24.1
	CM90L	21.0	14.4	25.5	30.5	21.0	37.0	58.0	102	27.1	32.6
	CM112S	23.5	15.0	27.0	34.0	22.0	39.0	60.0	108	67.4	87.5
	CM112M	31.0	20.5	35.0	45.0	30.0	51.0	82.0	140	87.4	108
	CM112L	45.0	30.0	48.0	65.0	44.0	70.0	120	192	128	148
	CM112H	68.0	43.0	73.0	95.0	60.0	102	172	292	189	209
4500	DS56M	1.0	1.65	1.65	-	-	-	6.6	6.6	0.47	0.85
	DS56L	2.0	2.4	-	-	-	-	9.6	-	0.82	1.2
	DS56H	4.0	4.0	-	-	-	-	16.0	-	1.53	1.88
	CM71S	5.0	4.9	8.5	7.3	7.2	12.3	20.0	34	4.85	6.89
	CM71M	6.5	6.6	11.3	9.4	9.6	16.4	26.0	45	6.27	8.31
	CM71L	9.5	9.6	17.1	13.8	14.0	25.0	38.0	68	9.1	11.1
	CM90S	11.0	11.1	18.9	16.0	16.2	27.5	44.0	76	14.3	19.8
	CM90M	14.5	14.7	26.0	21.0	21.5	37.5	59.0	104	18.6	24.1
	CM90L	21.0	21.6	39.0	30.5	31.5	57	86.0	156	27.1	32.6
	CM112S	23.5	22.5	38.5	34.0	32.5	56	90.0	154	67.4	87.5
	CM112M	31.0	30.0	54.0	45.0	44.0	78	120	216	87.4	108
	CM112L	45.0	46.0	78.0	65.0	67.0	113	184	312	128	148
	CM112H	68.0	66.0	-	95.0	92.0	-	264	-	189	209
6000	DS56M	1.0	1.65	-	-	-	-	6.6	-	0.47	0.85
	DS56L	2.0	2.75	-	-	-	-	11.0	-	0.82	1.2
	DS56H	4.0	5.3	-	-	-	-	21.0	-	1.53	1.88
	CM71S	5.0	6.5	11.6	7.3	7.2	16.8	26.0	46.5	4.85	6.89
	CM71M	6.5	8.6	14.1	9.4	9.6	20.5	34.0	56	6.27	8.31
	CM71L	9.5	12.5	21.5	13.8	14.0	31.0	50.0	86	9.1	11.1
	CM90S	11.0	14.5	23.5	16.0	16.2	34.0	58.0	94	14.3	19.8
	CM90M	14.5	19.8	37.0	21.0	21.5	54	79.0	148	18.6	24.1
	CM90L	21.0	29.5	51.0	30.5	31.5	74	118.0	204	27.1	32.6

- 1) For DS/CM synchronous servomotors with AC 400 V system voltage
 2) For DS/CM synchronous servomotors with AC 230 V system voltage



Motor Selection

Motor Selection for Synchronous Servomotors (SERVO)



NOTE

Additional project planning instructions and information on the DS/CM synchronous servomotors can be found in the "Servo Gearmotors" catalog, which can be ordered from SEW-EURODRIVE.

DS/CM motor selection (AC 400 V system voltage)

1. Rated speed $n_N = 2000$ 1/min:

Motor		MOVIDRIVE® compact MCS/MCH4_A...-5_3 (AC 400/500 V units) in SERVO operating modes (P700)											
		0015	0022	0030	0040	0055	0075	0110	0150	0220	0300	0370	0450
CM71S	M_{max} [Nm]	12.7	15.9	16.5									
CM71M	M_{max} [Nm]	12.7	16.7	19.8	21.5								
CM71L	M_{max} [Nm]	13.5	18.2	22.5	28.4	31.4							
CM90S	M_{max} [Nm]	13.4	18.4	23.2	30.6	38.2	39.4						
CM90M	M_{max} [Nm]	12.6	17.3	21.9	29.5	38.0	46.9	52.5					
CM90L	M_{max} [Nm]		17.5	22.2	30.1	39.3	49.6	70.3	75.8				
CM112S	M_{max} [Nm]		19.3	24.6	33.4	43.6	54.8	76.2	81.9				
CM112M	M_{max} [Nm]			23.9	32.6	42.9	54.7	79.3	99.6	108.0			
CM112L	M_{max} [Nm]					42.0	53.9	80.3	104.9	141.5	156.8		
CM112H	M_{max} [Nm]						53.2	80.1	106.5	150.3	189.2	220.1	237.0

2. Rated speed $n_N = 3000$ 1/min:

Motor		MOVIDRIVE® compact MCS/MCH4_A...-5_3 (AC 400/500 V units) in SERVO operating modes (P700)				
		0015	0022	0030	0040	0055
DS56M	M_{max} [Nm]	3.5	3.8			
DS56L	M_{max} [Nm]	4.9	6.6	7.6		
DS56H	M_{max} [Nm]	8.5	11.5	14.3	15.0	
CM71S	M_{max} [Nm]	8.9	11.9	14.3	16.5	
CM71M	M_{max} [Nm]	9.0	12.2	15.1	19.1	21.5
CM71L	M_{max} [Nm]	9.2	12.6	15.9	21.0	26.2
CM90S	M_{max} [Nm]	9.0	12.4	15.7	21.2	27.4
CM90M	M_{max} [Nm]		11.8	15.0	20.4	26.6
CM90L	M_{max} [Nm]				20.7	27.3
CM112S	M_{max} [Nm]				22.2	29.3
CM112M	M_{max} [Nm]					28.2

Motor		MOVIDRIVE® compact MCS/MCH4_A...-5_3 (AC 400/500 V units) in SERVO operating modes (P700)									
		0075	0110	0150	0220	0300	0370	0450	0550	0750	
CM71L	M_{max} [Nm]	30.8	31.5								
CM90S	M_{max} [Nm]	34.0	39.2								
CM90M	M_{max} [Nm]	33.7	47.8	51.6							
CM90L	M_{max} [Nm]	34.7	51.1	65.6	75.6						
CM112S	M_{max} [Nm]	37.4	54.8	69.8	81.9						
CM112M	M_{max} [Nm]	36.2	54.0	70.7	95.7	108.0					
CM112L	M_{max} [Nm]	35.8	53.9	71.6	101.0	126.9	147.4	156.8			
CM112H	M_{max} [Nm]		56.6	75.7	108.6	139.9	167.0	197.1	223.2	237.0	



3. Rated speed $n_N = 4500$ 1/min:

Motor		MOVIDRIVE® compact MCS/MCH4_A...-5_3 (AC 400/500 V units) in SERVO operating modes (P700)			
		0015	0022	0030	0040
DS56M	M_{max} [Nm]	3.5	3.8		
DS56L	M_{max} [Nm]	4.9	6.6	7.6	
DS56H	M_{max} [Nm]	6.0	8.2	10.3	13.7
CM71S	M_{max} [Nm]	6.1	8.3	10.4	13.4
CM71M	M_{max} [Nm]	5.9	8.1	10.2	13.6
CM71L	M_{max} [Nm]		8.2	10.4	14.0
CM90S	M_{max} [Nm]			10.4	14.1
CM90M	M_{max} [Nm]				14.0

Motor		MOVIDRIVE® compact MCS/MCH4_A...-5_3 (AC 400/500 V units) in SERVO operating modes (P700)											
		0055	0075	0110	0150	0220	0300	0370	0450	0550	0750	0900	1100
DS56H	M_{max} [Nm]	15.2											
CM71S	M_{max} [Nm]	16.1	16.5										
CM71M	M_{max} [Nm]	17.1	20.3	21.3									
CM71L	M_{max} [Nm]	18.1	22.5	30.3	31.2								
CM90S	M_{max} [Nm]	18.4	23.4	33.6	39.2								
CM90M	M_{max} [Nm]	18.4	23.5	34.6	44.5	52.1							
CM90L	M_{max} [Nm]	18.2	23.3	34.7	45.8	63.4	75.0						
CM112S	M_{max} [Nm]	19.5	25.0	37.4	49.2	67.5	81.9						
CM112M	M_{max} [Nm]		24.6	37.1	49.4	69.6	87.4	101.5	108.0				
CM112L	M_{max} [Nm]			35	46.8	67.2	86.9	104.1	123.5	140.7	156.8		
CM112H	M_{max} [Nm]					70.9	92.5	112.1	135.5	157.7	189.4	231.6	237.0

4. Rated speed $n_N = 6000$ 1/min:

Motor		MOVIDRIVE® compact MCS/MCH4_A...-5_3 (AC 400/500 V units) in SERVO operating modes (P700)											
		0015	0022	0030	0040	0055	0075	0110	0150	0220	0300	0370	0450
DS56M	M_{max} [Nm]	3.5	3.8										
DS56L	M_{max} [Nm]	4.3	5.8	7.3	7.6								
DS56H	M_{max} [Nm]	4.5	6.2	7.9	10.5	13.6	15.1						
CM71S	M_{max} [Nm]	4.6	6.3	8.0	10.6	13.3	15.8	16.5					
CM71M	M_{max} [Nm]		6.2	7.9	10.6	13.7	16.8	21.3					
CM71L	M_{max} [Nm]			8.0	10.8	14.1	17.9	25.2	30.7	31.4			
CM90S	M_{max} [Nm]				10.8	14.2	18.1	26.6	34.2	39.4			
CM90M	M_{max} [Nm]					13.7	17.5	26.1	34.3	46.9	51.9		
CM90L	M_{max} [Nm]						17.1	25.6	33.9	48.0	60.9	71.3	75.2



Motor Selection

Motor Selection for Synchronous Servomotors (SERVO)

DS/CM motor selection (AC 230 V system voltage)

1. Rated speed $n_N = 2000$ 1/min:

Motor		MOVIDRIVE® compact MCS/MCH4_A...-5_3 (AC 400/500 V units) in SERVO operating modes (P700)								
		0015	0022	0037	0055	0075	0110	0150	0220	0300
CM71S	M_{max} [Nm]	12.9	14.6	16.5						
CM71M	M_{max} [Nm]	13.1	15.1	21.4						
CM71L	M_{max} [Nm]	14.0	16.3	25.6	31.3					
CM90S	M_{max} [Nm]	13.8	16.2	26.8	38.0	39.6				
CM90M	M_{max} [Nm]	13.1	15.4	25.8	38.2	48.1	52.0			
CM90L	M_{max} [Nm]		15.8	26.6	40.0	51.9	70.9	74.9		
CM112S	M_{max} [Nm]			28.3	42.7	55.1	74.7	81.9		
CM112M	M_{max} [Nm]			27.4	41.6	54.6	76.8	94.4	108.0	
CM112L	M_{max} [Nm]				41.7	55.0	79.2	100.2	139.3	156.8
CM112H	M_{max} [Nm]					56.6	82.2	105.5	153	177.9

2. Rated speed $n_N = 3000$ 1/min:

Motor		MOVIDRIVE® compact MCS/MCH4_A...-5_3 (AC 400/500 V units) in SERVO operating modes (P700)								
		0015	0022	0037	0055	0075	0110	0150	0220	0300
DS56M	M_{max} [Nm]	3.8								
DS56L	M_{max} [Nm]	7.6								
DS56H	M_{max} [Nm]	9.2	10.7	15.3						
CM71S	M_{max} [Nm]	9.1	10.6	15.8	16.5					
CM71M	M_{max} [Nm]	9.3	10.9	17.2	21.5					
CM71L	M_{max} [Nm]	9.4	11.0	18.2	25.8	31.0	31.4			
CM90S	M_{max} [Nm]	9.5	11.2	18.7	27.7	35.1	39.5			
CM90M	M_{max} [Nm]			18.1	27.2	35.3	48.4	52.2		
CM90L	M_{max} [Nm]			17.9	27.1	35.5	50.5	63.1	75.2	
CM112S	M_{max} [Nm]			18.8	28.7	37.7	53.4	66.3	81.9	
CM112M	M_{max} [Nm]				29.1	38.4	55.3	69.9	97.0	108.0
CM112L	M_{max} [Nm]					40.6	58.9	75.4	108.8	125.9
CM112H	M_{max} [Nm]						58.4	75.3	111.1	131.1

3. Rated speed $n_N = 4500$ 1/min:

Motor		MOVIDRIVE® compact MCS/MCH4_A...-5_3 (AC 400/500 V units) in SERVO operating modes (P700)								
		0015	0022	0037	0055	0075	0110	0150	0220	0300
DS56M	M_{max} [Nm]	3.8								
CM71S	M_{max} [Nm]	6.4	7.5	12.1	16.3	16.5				
CM71M	M_{max} [Nm]	6.3	7.4	12.2	17.4	21.0	21.4			
CM71L	M_{max} [Nm]		7.2	12.1	17.9	22.8	29.9	31.3		
CM90S	M_{max} [Nm]			12.6	19.0	24.8	34.4	39.6		
CM90M	M_{max} [Nm]			12.1	18.3	24.1	34.3	42.8	52.0	
CM90L	M_{max} [Nm]				17.7	23.4	33.7	42.9	61.4	70.5
CM112S	M_{max} [Nm]				20.0	26.5	38.2	48.6	68.3	77.7
CM112M	M_{max} [Nm]					24.8	36.1	46.3	67.4	78.5

4. Rated speed $n_N = 6000$ 1/min:

Motor		MOVIDRIVE® compact MCS/MCH4_A...-5_3 (AC 400/500 V units) in SERVO operating modes (P700)								
		0015	0022	0037	0055	0075	0110	0150	0220	0300
CM71S	M_{max} [Nm]	4.7	5.6	9.2	13.2	15.9	16.6			
CM71M	M_{max} [Nm]	5.0	5.9	9.9	14.6	18.2	21.4			
CM71L	M_{max} [Nm]			9.6	14.5	18.7	25.6	30.3	31.4	
CM90S	M_{max} [Nm]			10.2	15.4	20.1	28.5	35.3	39.4	
CM90M	M_{max} [Nm]				12.9	17.0	24.5	31.2	44.3	50.6
CM90L	M_{max} [Nm]					17.9	25.9	33.1	48.3	56.5



4 Index of Changes

4.1 Changes compared to the previous version

The following section lists the changes made to the individual sections from edition 04/2002, publication number 10538313 (EN).

System description

- The new option USB11A has been included in the subsection "System overview."

Technical data and dimension drawings

- All the tightening torques according to EN 61800-5-1 have been included in the catalog.
- The subsection "Interface adapter type USB11A / option DKG11A" has been added.
- The subsection "MOVIDRIVE[®] MDR60A regenerative power supply units" has been completely revised.
- The DBG11B-15 version has been included in the subsection "DBG11B keypad."
- The trip currents I_F have been updated in the subsection "BW.. braking resistors." The braking resistors BW...-T and BW...-P have been added.
- Type ND030-023 has been included in the subsection "ND.. line chokes." The dimension drawings for the line chokes have been revised.
- The dimension drawings have been revised in the subsection "HF.. output filters."
- The subsection "Prefabricated cables" has been completely revised.

Motor selection

- The motor tables have been revised in the subsection "Motor selection for asynchronous servomotors (CFC)." The motor/inverter assignments have been updated.



5 Index

Numerics

5 V encoder supply DWI11A67

A

Application modules

Overview16

Application version

Additional functions12

B

Block circuit diagram for MOVIDRIVE® compact .9

Braking resistors BW... / BW...-T / BW...-P68

Assignment to AC 230 V units72

Assignment to AC 400/500 V units69

Flat design68

Parallel connection69

Technical data for braking resistors BW...-T /

BW...-P72

UL and cUL approval68

Wire and grid resistors68

BS touch guard74

C

C-Tick approval25

CE marking25

Control modes, general description7

D

DBG11B keypad64

Dimension drawing

Line filter NF...79

Dimension drawings

Basic unit size 153

Basic unit size 254

Basic unit size 355

Basic unit size 456

Basic unit size 557

Braking resistors BW... / BW...-T / BW...-P ..73

DBG11B keypad64

DKB11A heat sink for braking resistors in

flatpack design75

HD... output choke80

HF... output filters83

Line choke ND..76

Serial interface USS21A65

Touch guard BS74

DKB11A75

DWI11A67

E

Electronic cam12

G

General description7

GOST-R certificate25

I

Index of changes 129

Changes compared to the

previous version 129

Interface adapter

USB11A 66

Internal synchronous operation

Description 14

IPOSplus® 63

General description 7

L

Line choke ND.. 76

Line filter NF...-... 78

M

Motor selection for asynchronous AC motors

(VFC)

Basic recommendations 98, 106

Dynamic applications 99

Examples for delta/star

AC 230/400 V / 50 Hz 102

Motor selection for delta AC 230 V / 50 Hz 104

Motor selection for

delta/star AC 230/400 V / 50 Hz ... 101

Motor selection for

double-star 230 V / 60 Hz 105

Motor selection for double-star/star

AC 230/460 V / 60 Hz 103

Speed/torque characteristic curve 99

Voltage/frequency characteristic curve 98

Motor selection for asynchronous

servomotors (CFC)

CT/CV motor selection 111

CT/CV motor selection for rated speed

1200 1/min 111

CT/CV motor selection for rated speed

1700 1/min 112

CT/CV motor selection for rated speed

2100 1/min 113

CT/CV motor selection for rated speed

3000 1/min 114

CT/CV motor table 110

DT/DV motor selection for delta

AC 230 V / 50 Hz 121

DT/DV motor selection for delta/star

AC 230/400 V / 50 Hz 117

DT/DV motor selection in double star

AC 230 V / 60 Hz 122

DT/DV/D motor selection in double-star/star

AC 230/460 V / 60 Hz 119

Magnetizing current 107

Motor characteristics 106

Motor tables DT/DV 115

Notes for CT/CV motors 109



Torque control	108	General description	7
Motor selection for synchronous servomotors (SERVO)		System overview	
Basic recommendations	124	Communication and technology components	5
DS/CM motor selection AC 230 V, rated speed 2000 1/min	128	Power components	4
DS/CM motor selection AC 230 V, rated speed 3000 1/min	128	System bus (SBus)	
DS/CM motor selection AC 230 V, rated speed 4500 1/min	128	Technical data	47, 51
DS/CM motor selection AC 230 V, rated speed 6000 1/min	128	T	
DS/CM motor selection AC 400 V, rated speed 2000 1/min	126	Technical data	
DS/CM motor selection AC 400 V, rated speed 3000 1/min	126	Prefabricated cables	85
DS/CM motor selection AC 400 V, rated speed 4500 1/min	127	Technical data	
DS/CM motor selection AC 400 V, rated speed 6000 1/min	127	5 V encoder supply DWI11A	67
DS/CM motor table	125	AC 230 V units	
Motor characteristics	123	Size 1	38
Torque control	124	Size 2	40
MOVIDRIVE® MDR60A regenerative power supply unit		Size 3	42
Cable sets for the DC link connection	62	Size 4	44
Description	58	AC 400/500 V units	
Dimension drawings	61	Size 1	28
General technical data	59	Size 2	30
Technical data for sizes 3, 4, 6	60	Size 3	32
UL approval	58	Size 4	34
MOVILINK®	7	Size 5	36
MOVITOOLS® operating software	24	BS touch guard	74
O		BW... braking resistors / BW...-T / BW...-P ..	68
Option DKG11A	66	DBG11B keypad	64
Output choke HD...	80	DKB11A heat sink for brake resistors in flatpack design	75
Output filter HF...	81	Electronics data for MCH4_A basic units	50
Overview of MOVIDRIVE® compact units	8	Electronics data for MCF/MCV/MCS4_A basic units	46
Overview of series and variants	7	General technical data	27
P		Interface adapter USB11A	66
Prefabricated cables	85	IPOSplus®	63
Cable sets for connection to X14/X15 on MCV / MCS / MCH basic units	88	Line choke ND.. option	76
Meaning of the symbols	88	Line filter NF...-...	78
Overview of the cable sets for connection at X14 on MCV/MCS basic unit	96	Output choke HD...	80
Overview of the cable sets for connection at X15 on the MCH basic unit	94	Output filter HF...	81
Overview of the cable sets for connection at X15 on the MCS basic unit	92	Serial interface USS21A	65
Overview of the cable sets for connection at X15 on the MCV basic unit	89	Systembus (SBus)	47, 51
S		Technology function	
Serial interface USS21A	65	Electronic cam	12
System bus (SBus)		U	
		UL/cUL approval	25
		Unit designation	26
		Unit functions and properties	10
		Unit variants MCF/MCV/MCS/MCH	6
		Unit versions	
		Application version	6
		Standard version	6
		USB11A	66



Address Directory

Germany				
Headquarters Production Sales	Bruchsal	SEW-EURODRIVE GmbH & Co KG Ernst-Blickle-Straße 42 D-76646 Bruchsal P.O. Box Postfach 3023 • D-76642 Bruchsal	Tel. +49 7251 75-0 Fax +49 7251 75-1970 http://www.sew-eurodrive.de sew@sew-eurodrive.de	
	Production	Graben	SEW-EURODRIVE GmbH & Co KG Ernst-Blickle-Straße 1 D-76676 Graben-Neudorf P.O. Box Postfach 1220 • D-76671 Graben-Neudorf	
		Östringen	SEW-EURODRIVE Östringen GmbH Franz-Gurk-Straße 2 D-76684 Östringen P.O. Box Postfach 1174 • D-76677 Östringen	
Service Competence Center	Central Gear units / Motors	SEW-EURODRIVE GmbH & Co KG Ernst-Blickle-Straße 1 D-76676 Graben-Neudorf	Tel. +49 7251 75-1710 Fax +49 7251 75-1711 sc-mitte-gm@sew-eurodrive.de	
	Central Electronics	SEW-EURODRIVE GmbH & Co KG Ernst-Blickle-Straße 42 D-76646 Bruchsal	Tel. +49 7251 75-1780 Fax +49 7251 75-1769 sc-mitte-e@sew-eurodrive.de	
	North	SEW-EURODRIVE GmbH & Co KG Alte Ricklinger Straße 40-42 D-30823 Garbsen (near Hannover)	Tel. +49 5137 8798-30 Fax +49 5137 8798-55 sc-nord@sew-eurodrive.de	
	East	SEW-EURODRIVE GmbH & Co KG Dänkritzer Weg 1 D-08393 Meerane (near Zwickau)	Tel. +49 3764 7606-0 Fax +49 3764 7606-30 sc-ost@sew-eurodrive.de	
	South	SEW-EURODRIVE GmbH & Co KG Domagkstraße 5 D-85551 Kirchheim (near München)	Tel. +49 89 909552-10 Fax +49 89 909552-50 sc-sued@sew-eurodrive.de	
	West	SEW-EURODRIVE GmbH & Co KG Siemensstraße 1 D-40764 Langenfeld (near Düsseldorf)	Tel. +49 2173 8507-30 Fax +49 2173 8507-55 sc-west@sew-eurodrive.de	
	Drive Service Hotline / 24 Hour Service		+49 180 5 SEWHELP +49 180 5 7394357	
	Technical Offices	Augsburg	SEW-EURODRIVE GmbH & Co KG August-Wessels-Straße 29 D-86156 Augsburg	Tel. +49 821 22779-10 Fax +49 821 22779-50 tb-augsburg@sew-eurodrive.de
Berlin		SEW-EURODRIVE GmbH & Co KG Lilienthalstraße 3a D-12529 Schönefeld	Tel. +49 33762 2266-30 Fax +49 33762 2266-36 tb-berlin@sew-eurodrive.de	
Bodensee		SEW-EURODRIVE GmbH & Co KG Burgbergring 91 D-88662 Überlingen	Tel. +49 7551 9226-30 Fax +49 7551 9226-56 tb-bodensee@sew-eurodrive.de	
Bremen		SEW-EURODRIVE GmbH & Co KG Bornstr.19 ... 22 D-28195 Bremen	Tel. +49 421 33918-10 Fax +49 421 33918-22 tb-bremen@sew-eurodrive.de	
Dortmund		SEW-EURODRIVE GmbH & Co KG Hildastraße 10 D-44145 Dortmund	Tel. +49 231 912050-10 Fax +49 231 912050-20 tb-dortmund@sew-eurodrive.de	
Dresden		SEW-EURODRIVE GmbH & Co KG Hauptstraße 32 D-01445 Radebeul	Tel. +49 351 26338-0 Fax +49 351 26338-38 tb-dresden@sew-eurodrive.de	
Erfurt		SEW-EURODRIVE GmbH & Co KG Blumenstraße 70 D-99092 Erfurt	Tel. +49 361 21709-70 Fax +49 361 21709-79 tb-erfurt@sew-eurodrive.de	
Güstrow		SEW-EURODRIVE GmbH & Co KG Thünenweg 19 D-18273 Güstrow P.O. Box Postfach 1216 • D-18262 Güstrow	Tel. +49 3843 8557-80 Fax +49 3843 8557-88 tb-guestrow@sew-eurodrive.de	



Germany		
Hamburg	SEW-EURODRIVE GmbH & Co KG Bramfelder Straße 119 D-23305 Hamburg	Tel. +49 40 298109-60 Fax +49 40 298109-70 tb-hamburg@sew-eurodrive.de
Hannover/ Garbsen	SEW-EURODRIVE GmbH & Co KG Alte Ricklinger Str.40-42 D-30823 Garbsen P.O. Box Postfach 1104 53 • D-30804 Garbsen	Tel. +49 5137 8798-10 Fax +49 5137 8798-50 tb-hannover@sew-eurodrive.de
Heilbronn	SEW-EURODRIVE GmbH & Co KG Zeppelinstraße 7 D-74357 Bönnigheim P.O. Box Postfach 68 • D-74355 Bönnigheim	Tel. +49 7143 8738-0 Fax +49 7143 8738-25 tb-heilbronn@sew-eurodrive.de
Herford	SEW-EURODRIVE GmbH & Co KG Radewiger Straße 21 D-32052 Herford P.O. Box Postfach 4108 • D-32025 Herford	Tel. +49 5221 9141-0 Fax +49 5221 9141-20 tb-herford@sew-eurodrive.de
Karlsruhe	SEW-EURODRIVE GmbH & Co KG Ettlinger Weg 2 D-76467 Bietigheim P.O. Box Postfach 43 • D-76463 Bietigheim	Tel. +49 7245 9190-10 Fax +49 7245 9190-20 tb-karlsruhe@sew-eurodrive.de
Kassel	SEW-EURODRIVE GmbH & Co KG Lange Straße 14 D-34253 Lohfelden	Tel. +49 561 95144-80 Fax +49 561 95144-90 tb-kassel@sew-eurodrive.de
Koblenz	SEW-EURODRIVE GmbH & Co KG Bahnstraße 17a D-56743 Mendig	Tel. +49 2652 9713-30 Fax +49 2652 9713-40 tb-koblenz@sew-eurodrive.de
Laahr	SEW-EURODRIVE GmbH & Co KG Europastraße 3 D-77933 Laahr / Schwarzwald	Tel. +49 7821 90999-60 Fax +49 7821 90999-79 tb-laahr@sew-eurodrive.de
Langenfeld	SEW-EURODRIVE GmbH & Co KG Siemensstraße 1 D-40764 Langenfeld	Tel. +49 2173 8507-10 Fax +49 2173 8507-50 tb-langenfeld@sew-eurodrive.de
Magdeburg	SEW-EURODRIVE GmbH & Co KG Burgstraße 7 D-39326 Wolmirstedt	Tel. +49 39201 7004-1 Fax +49 39201 7004-9 tb-magdeburg@sew-eurodrive.de
Mannheim	SEW-EURODRIVE GmbH & Co KG Radeberger Straße 2 D-68309 Mannheim	Tel. +49 621 71683-10 Fax +49 621 71683-22 tb-mannheim@sew-eurodrive.de
München	SEW-EURODRIVE GmbH & Co KG Domagkstraße 5 D-85551 Kirchheim	Tel. +49 89 90955-110 Fax +49 89 90955-150 tb-muenchen@sew-eurodrive.de
Münster	SEW-EURODRIVE GmbH & Co KG Von-Vincke-Straße 14 D-48143 Münster	Tel. +49 251 41475-11 Fax +49 251 41475-50 tb-muenster@sew-eurodrive.de
Nürnberg	SEW-EURODRIVE GmbH & Co KG Plattenäckerweg 6 D-90455 Nürnberg	Tel. +49 911 98884-50 Fax +49 911 98884-60 tb-nuernberg@sew-eurodrive.de
Regensburg	SEW-EURODRIVE GmbH & Co KG Im Gewerbepark A15 D-93059 Regensburg	Tel. +49 941 46668-68 Fax +49 941 46668-66 tb-regensburg@sew-eurodrive.de
Rhein-Main	SEW-EURODRIVE GmbH & Co KG Niederstedter Weg 5 D-61348 Bad Homburg	Tel. +49 6172 9617-0 Fax +49 6172 9617-50 tb-rheinmain@sew-eurodrive.de
Stuttgart	SEW-EURODRIVE GmbH & Co KG Friedrich-List-Straße 46 D-70771 Leinfelden-Echterdingen	Tel. +49 711 16072-0 Fax +49 711 16072-72 tb-stuttgart@sew-eurodrive.de
Ulm	SEW-EURODRIVE GmbH & Co KG Dieselstraße 14 D-89160 Dornstadt	Tel. +49 7348 9885-0 Fax +49 7348 9885-90 tb-ulm@sew-eurodrive.de



Address Directory

Germany			
	Würzburg	SEW-EURODRIVE GmbH & Co KG Nürnbergerstraße 118 D-97076 Würzburg-Lengfeld	Tel. +49 931 27886-60 Fax +49 931 27886-66 tb-wuerzburg@sew-eurodrive.de
	Zwickau / Meerane	SEW-EURODRIVE GmbH & Co KG Dänkritzer Weg1 D-08393 Meerane	Tel. +49 3764 7606-0 Fax +49 3764 7606-20 tb-zwickau@sew-eurodrive.de
France			
Production Sales Service	Hagenau	SEW-USOCOME 48-54, route de Soufflenheim B. P. 20185 F-67506 Hagenau Cedex	Tel. +33 3 88 73 67 00 Fax +33 3 88 73 66 00 http://www.usocome.com sew@usocome.com
Production	Forbach	SEW-EUROCOME Zone Industrielle Technopole Forbach Sud – B. P. 30269 F-57604 Forbach Cedex	Tel. +33 3 87 29 38 00
Assembly Sales Service	Bordeaux	SEW-USOCOME Parc d'activités de Magellan 62, avenue de Magellan - B. P. 182 F-33607 Pessac Cedex	Tel. +33 5 57 26 39 00 Fax +33 5 57 26 39 09
	Lyon	SEW-USOCOME Parc d'Affaires Roosevelt Rue Jacques Tati F-69120 Vaulx en Velin	Tel. +33 4 72 15 37 00 Fax +33 4 72 15 37 15
	Paris	SEW-USOCOME Zone industrielle 2, rue Denis Papin F-77390 Verneuil l'Etang	Tel. +33 1 64 42 40 80 Fax +33 1 64 42 40 88
Technical Offices	Alsace Franche-Comté	SEW-USOCOME 1, rue Auguste Gasser F-68360 Soultz	Tel. +33 3 89 74 51 62 Fax +33 3 89 76 58 71
	Alsace Nord	SEW-USOCOME 15, rue Mambourg F-68240 Sigolsheim	Tel. +33 3 89 78 45 11 Fax +33 3 89 78 45 12
	Aquitaine	SEW-USOCOME Parc d'activités de Magellan 62, avenue de Magellan B.P.182 F-33607 Pessac Cedex	Tel. +33 5 57 26 39 00 Fax +33 5 57 26 39 09
	Ardennes Lorraine	SEW-USOCOME 7, rue de Prény F-54000 Nancy	Tel. +33 3 83 96 28 04 Fax +33 3 83 96 28 07
	Bourgogne	SEW-USOCOME 10, rue de la Poste F-71350 Saint Loup Géanges	Tel. +33 3 85 49 92 18 Fax +33 3 85 49 92 19
	Bretagne Ouest	SEW-USOCOME 4, rue des Châtaigniers F-44830 Brains	Tel. +33 2 51 70 54 04 Fax +33 2 51 70 54 05
	Centre Auvergne	SEW-USOCOME 27, avenue du Colombier F-19150 Laguenne	Tel. +33 5 55 20 12 10 Fax +33 5 55 20 12 11
	Centre Pays de Loire	SEW-USOCOME 9, rue des Erables F-37540 Saint Cyr sur Loire	Tel. +33 2 47 41 33 23 Fax +33 2 47 41 34 03
	Champagne	SEW-USOCOME 2, chemin des Suivots F-10120 Saint André les Vergers	Tel. +33 3 25 79 63 24 Fax +33 3 25 79 63 25
	Lyon Nord-Est	SEW-USOCOME Parc d'Affaires Roosevelt Rue Jacques Tati F-69120 Vaulx en Velin	Tel. +33 4 72 15 37 03 Fax +33 4 72 15 37 15



France			
	Lyon Ouest	SEW-USOCOME Parc d'Affaires Roosevelt Rue Jacques Tati F-69120 Vaulx en Velin	Tel. +33 4 72 15 37 04 Fax +33 4 72 15 37 15
	Lyon Sud-Est	SEW-USOCOME Montée de la Garenne F-26750 Génissieux	Tel. +33 4 75 05 65 95 Fax +33 4 75 05 65 96
	Nord	SEW-USOCOME 348, rue du Calvaire F-59213 Bermerain Cidex 102	Tel. +33 3 27 27 07 88 Fax +33 3 27 27 24 41
	Normandie	SEW-USOCOME 5 rue de la Limare F-14250 Brouay	Tel. +33 2 31 37 92 86 Fax +33 2 31 74 68 15
	Paris Est	SEW-USOCOME Résidence Le Bois de Grâce 2, allée des Souches Vertes F-77420 Champs sur Marne	Tel. +33 1 64 68 40 50 Fax +33 1 64 68 45 00
	Paris Ouest	SEW-USOCOME 42 avenue Jean Jaurès F-78580 Maule	Tel. +33 1 30 90 89 86 Fax +33 1 30 90 93 15
	Paris Picardie	SEW-USOCOME 25 bis, rue Kléber F-92300 Levallois Perret	Tel. +33 1 41 05 92 74 Fax +33 1 41 05 92 75
	Paris Sud	SEW-USOCOME 6. chemin des Bergers Lieu-dit Marchais F-91410 Roinville sous Dourdan	Tel. +33 1 60 81 10 56 Fax +33 1 60 81 10 57
	Provence	SEW-USOCOME Résidence Les Hespérides Bât. B2 67, boulevard des Alpes F-13012 Marseille	Tel. +33 4 91 18 00 11 Fax +33 4 91 18 00 12
	Pyrénées	SEW-USOCOME 271, Lieu-dit Ninaut F-31190 Caujac	Tel. +33 5 61 08 15 85 Fax +33 5 61 08 16 44
	Sud-Atlantique	SEW-USOCOME 12, rue des Pinsons F-44120 Vertou	Tel. +33 2 40 80 32 23 Fax +33 2 40 80 32 13
Algeria			
Sales	Alger	Réducom 16, rue des Frères Zagnoun Bellevue El-Harrach 16200 Alger	Tel. +213 21 8222-84 Fax +213 21 8222-84
Argentina			
Assembly Sales Service	Buenos Aires	SEW EURODRIVE ARGENTINA S.A. Centro Industrial Garin, Lote 35 Ruta Panamericana Km 37,5 1619 Garin	Tel. +54 3327 4572-84 Fax +54 3327 4572-21 sewar@sew-eurodrive.com.ar
Australia			
Assembly Sales Service	Melbourne	SEW-EURODRIVE PTY. LTD. 27 Beverage Drive Tullamarine, Victoria 3043	Tel. +61 3 9933-1000 Fax +61 3 9933-1003 http://www.sew-eurodrive.com.au enquires@sew-eurodrive.com.au
	Sydney	SEW-EURODRIVE PTY. LTD. 9, Sleigh Place, Wetherill Park New South Wales, 2164	Tel. +61 2 9725-9900 Fax +61 2 9725-9905 enquires@sew-eurodrive.com.au
	Perth	SEW-EURODRIVE PTY. LTD. 105 Robinson Avenue Belmont, W.A. 6104	Tel. +61 8 9478-2688 Fax +61 8 9277-7572 enquires@sew-eurodrive.com.au
	Brisbane	SEW-EURODRIVE PTY.LTD. 1 /34 Collinsvale St Rocklea, Queensland, 4106	Tel. +61 7 3272-7900 Fax +61 7 3272-7901 enquires@sew-eurodrive.com.au



Address Directory

Australia			
Technical Offices	Adelaide	SEW-EURODRIVE PTY. LTD. Unit 1/601 Anzac Highway Glenelg, S.A. 5045	Tel. +61 8 8294-8277 Fax +61 8 8294-2893 enquires@sew-eurodrive.com.au
	Townsville	SEW-EURODRIVE PTY. LTD. 12 Leyland Street Garbutt, QLD 4814	Tel. +61 7 4779 4333 Fax +61 7 4779 5333 enquires@sew-eurodrive.com.au
Austria			
Assembly Sales Service	Wien	SEW-EURODRIVE Ges.m.b.H. Richard-Strauss-Strasse 24 A-1230 Wien	Tel. +43 1 617 55 00-0 Fax +43 1 617 55 00-30 http://sew-eurodrive.at sew@sew-eurodrive.at
Technical Offices	Linz	SEW-EURODRIVE Ges.m.b.H. Reuchlinstr. 6/3 A-4020 Linz	Tel. +43 732 655 109-0 Fax +43 732 655 109-20 tb-linz@sew-eurodrive.at
	Graz	SEW-EURODRIVE Ges.m.b.H. Grabenstraße 231 A-8045 Graz	Tel. +43 316 685 756-0 Fax +43 316 685 755 tb-graz@sew-eurodrive.at
	Dornbirn	SEW-EURODRIVE Ges.m.b.H. Lustenauerstraße 27/1 A-6850 Dornbirn	Tel. +43 5572 3725 99-0 Fax +43 5572 3725 99-20 tb-dornbirn@sew-eurodrive.at
Bangladesh			
Sales	Dhaka	Triangle Trade International Bldg-5, Road-2, Sec-3, Uttara Model Town Dhaka-1230 Bangladesh	Tel. +880 2 8912246 Fax +880 2 8913344
Belgium			
Assembly Sales Service	Brüssel	SEW Caron-Vector S.A. Avenue Eiffel 5 B-1300 Wavre	Tel. +32 10 231-311 Fax +32 10 231-336 http://www.caron-vector.be info@caron-vector.be
Technical Office	Vlaanderen	SEW Caron-Vector S.A. Industrieweg 112-114 B-9032 Gent (Wondelgem)	Tel. +32 92 273-452 Fax +32 92 274-155
Brazil			
Production Sales Service	Sao Paulo	SEW-EURODRIVE Brasil Ltda. Avenida Amâncio Gaiolli, 50 Caixa Postal: 201-07111-970 Guarulhos/SP - Cep.: 07251-250	Tel. +55 11 6489-9133 Fax +55 11 6480-3328 http://www.sew.com.br sew@sew.com.br
Additional addresses for service in Brazil provided on request!			
Bulgaria			
Sales	Sofia	BEVER-DRIVE GmbH Bogdanovetz Str.1 BG-1606 Sofia	Tel. +359 2 9151160 Fax +359 2 9151166 bever@fastbg.net
Cameroon			
Sales	Douala	Electro-Services Rue Drouot Akwa B.P. 2024 Douala	Tel. +237 4322-99 Fax +237 4277-03
Canada			
Assembly Sales Service	Toronto	SEW-EURODRIVE CO. OF CANADA LTD. 210 Walker Drive Bramalea, Ontario L6T3W1	Tel. +1 905 791-1553 Fax +1 905 791-2999 http://www.sew-eurodrive.ca l.reynolds@sew-eurodrive.ca
	Vancouver	SEW-EURODRIVE CO. OF CANADA LTD. 7188 Honeyman Street Delta. B.C. V4G 1 E2	Tel. +1 604 946-5535 Fax +1 604 946-2513 b.wake@sew-eurodrive.ca



Canada			
	Montreal	SEW-EURODRIVE CO. OF CANADA LTD. 2555 Rue Leger LaSalle, Quebec H8N 2V9	Tel. +1 514 367-1124 Fax +1 514 367-3677 a.peluso@sew-eurodrive.ca
Additional addresses for service in Canada provided on request!			
Chile			
Assembly Sales Service	Santiago de Chile	SEW-EURODRIVE CHILE LTDA. Las Encinas 1295 Parque Industrial Valle Grande LAMPA RCH-Santiago de Chile P.O. Box Casilla 23 Correo Quilicura - Santiago - Chile	Tel. +56 2 75770-00 Fax +56 2 75770-01 http://www.sew-eurodrive.cl ventas@sew-eurodrive.cl
China			
Production Assembly Sales Service	Tianjin	SEW-EURODRIVE (Tianjin) Co., Ltd. No. 46, 7th Avenue, TEDA Tianjin 300457	Tel. +86 22 25322612 Fax +86 22 25322611 gm-tianjin@sew-eurodrive.cn http://www.sew-eurodrive.com.cn
Assembly Sales Service	Suzhou	SEW-EURODRIVE (Suzhou) Co., Ltd. 333, Suhong Middle Road Suzhou Industrial Park Jiangsu Province, 215021 P. R. China	Tel. +86 512 62581781 Fax +86 512 62581783 suzhou@sew.com.cn
	Guangzhou	SEW-EURODRIVE (Guangzhou) Co., Ltd. No. 9, JunDa Road East Section of GETDD Guangzhou 510530 P. R. China	Tel. +86 20 82267890 Fax +86 20 82267891 sewguangzhou@sew.com.cn
	Shenyang	SEW-EURODRIVE (Shenyang) Co., Ltd. 10A-2, 6th Road Shenyang Economic Technological -Development Area Shenyang, 110141 P. R. China	Tel. +86 24 22521596 Fax +86 24 22521579 shenyang@sew.com.cn
Colombia			
Assembly Sales Service	Bogotá	SEW-EURODRIVE COLOMBIA LTDA. Calle 22 No. 132-60 Bodega 6, Manzana B Santafé de Bogotá	Tel. +57 1 54750-50 Fax +57 1 54750-44 http://www.sew-eurodrive.com.co sewcol@sew-eurodrive.com.co
Croatia			
Sales Service	Zagreb	KOMPEKS d. o. o. PIT Erdödy 4 II HR 10 000 Zagreb	Tel. +385 1 4613-158 Fax +385 1 4613-158 kompeks@net.hr
Czech Republic			
Sales	Praha	SEW-EURODRIVE CZ S.R.O. Business Centrum Praha Luzna 591 CZ-16000 Praha 6 - Vokovice	Tel. +420 220121234 Fax +420 220121237 http://www.sew-eurodrive.cz sew@sew-eurodrive.cz
Technical Offices	Brno	SEW-EURODRIVE CZ S.R.O. Krenova 52 CZ -60200 Brno	Tel. +420 543256151 + 543256163 Fax +420 543256845
	Hradec Kralove	SEW-EURODRIVE CZ S.R.O. Technicka Kancelar - vychodni Cechy Svermova CZ-53374 Horni Jeleni	Tel. +420 466673711 Fax +420 466673634
	Klatovy	SEW-EURODRIVE CZ S.R.O. Technical Office Klatovy Kollarova 528 CZ-33901 Klatovy 3	Tel. +420 376310729 Fax +420 376310725



Address Directory

Denmark			
Assembly Sales Service	Kopenhagen	SEW-EURODRIVE A/S Geminivej 28-30 DK-2670 Greve	Tel. +45 43 9585-00 Fax +45 43 9585-09 http://www.sew-eurodrive.dk sew@sew-eurodrive.dk
Egypt			
Sales Service	Cairo	Copam Egypt for Engineering & Agencies 33 El Hegaz ST, Heliopolis, Cairo	Tel. +20 2 2566-299 + 1 23143088 Fax +20 2 2594-757 http://www.copam-egypt.com/ copam@datum.com.eg
Estonia			
Sales	Tallin	ALAS-KUUL AS Reti tee 4 EE-75301 Peetri küla, Rae vald, Harjumaa	Tel. +372 6593230 Fax +372 6593231 veiko.soots@alas-kuul.ee
Finland			
Assembly Sales Service	Lahti	SEW-EURODRIVE OY Vesimäentie 4 FIN-15860 Hollola 2	Tel. +358 201 589-300 Fax +358 3 780-6211 sew@sew.fi http://www.sew-eurodrive.fi
Technical Offices	Helsinki	SEW-EURODRIVE OY Luutnantinaukio 5C LT2 FIN-00410 Helsinki	Tel. +358 201 589-300 Fax + 358 9 5666-311 sew@sew.fi
	Vaasa	SEW-EURODRIVE OY Kauppapuistikko 11 E FIN-65100 Vaasa	Tel. +358 3 589-300 Fax +358 6 3127-470
Gabon			
Sales	Libreville	Electro-Services B.P. 1889 Libreville	Tel. +241 7340-11 Fax +241 7340-12
Great Britain			
Assembly Sales Service	Normanton	SEW-EURODRIVE Ltd. Beckbridge Industrial Estate P.O. Box No.1 GB-Normanton, West- Yorkshire WF6 1QR	Tel. +44 1924 893-855 Fax +44 1924 893-702 http://www.sew-eurodrive.co.uk info@sew-eurodrive.co.uk
Technical Offices	London	SEW-EURODRIVE Ltd. 764 Finchely Road, Temple Fortune GB-London N.W.11 7TH	Tel. +44 20 8458-8949 Fax +44 20 8458-7417
	Midlands	SEW-EURODRIVE Ltd. 5 Sugar Brook court, Aston Road, Bromsgrove, Worcs B60 3EX	Tel. +44 1527 877-319 Fax +44 1527 575-245
	Scotland	SEW-EURODRIVE Ltd. Scottish Office No 37 Enterprise House Springkerse Business Park GB-Stirling FK7 7UF Scotland	Tel. +44 17 8647-8730 Fax +44 17 8645-0223
Greece			
Sales Service	Athen	Christ. Boznos & Son S.A. 12, Mavromichali Street P.O. Box 80136, GR-18545 Piraeus	Tel. +30 2 1042 251-34 Fax +30 2 1042 251-59 http://www.boznos.gr info@boznos.gr
Technical Office	Thessaloniki	Christ. Boznos & Son S.A. Maiandrou 15 562 24 Evosmos, Thessaloniki	Tel. +30 2 310 7054-00 Fax +30 2 310 7055-15 info@boznos.gr



Hong Kong			
Assembly Sales Service	Hong Kong	SEW-EURODRIVE LTD. Unit No. 801-806, 8th Floor Hong Leong Industrial Complex No. 4, Wang Kwong Road Kowloon, Hong Kong	Tel. +852 2 7960477 + 79604654 Fax +852 2 7959129 sew@sewhk.com
Hungary			
Sales Service	Budapest	SEW-EURODRIVE Kft. H-1037 Budapest Kunigunda u. 18	Tel. +36 1 437 06-58 Fax +36 1 437 06-50 office@sew-eurodrive.hu
Iceland			
Sales	Reykjavik	Vélaverk ehf. Bolholti 8, 3h. IS - 105 Reykjavik	Tel. +354 568 3536 Fax +354 568 3537 velaverk@velaverk.is
India			
Assembly Sales Service	Baroda	SEW-EURODRIVE India Pvt. Ltd. Plot No. 4, Gidc Por Ramangamdi • Baroda - 391 243 Gujarat	Tel. +91 265 2831086 Fax +91 265 2831087 http://www.seweurodriveindia.com mdoffice@seweurodriveindia.com
Technical Offices	Bangalore	SEW-EURODRIVE India Private Limited 308, Prestige Centre Point 7, Edward Road Bangalore	Tel. +91 80 22266565 Fax +91 80 22266569 salesbang@seweurodriveinindia.com
	Calcutta	SEW EURODRIVE INDIA PVT. LTD. Juthika Apartment, Flat No. B1 11/1, Sunny Park Calcutta - 700 019	Tel. +91 33 24615820 Fax +91 33 24615826 sewcal@cal.vsnl.net.in
	Chennai	SEW-EURODRIVE India Private Limited F2, 1st Floor, Sarvamangala Indira New No. 67, Bazullah Road Chennai - 600 017	Tel. +91 44 28144461 Fax +91 44 28144463 saleschen@seweurodriveindia.com
	Hyderabad	SEW-EURODRIVE India Pvt. Limited 408, 4th Floor, Meridian Place Green Park Road Amerpeet Hyderabad	Tel. +91 40 23414698 Fax +91 40 23413884 saleshyd@seweurodriveindia.com
	Mumbai	SEW-EURODRIVE India Private Limited 312 A, 3rd Floor, Acme Plaza Andheri Kurla Road, Andheri (E) Mumbai	Tel. +91 22 28348440 Fax +91 22 28217858 salesmumbai@seweurodriveindia.com
	New Delhi	SEW-EURODRIVE India Private Limited 303 Kirti Deep, 2-Nangal Raya Business Centre New Delhi 110 046	Tel. +91 11 28521566 Fax +91 11 28521577 salesdelhi@seweurodriveindia.com
	Pune	SEW-EURODRIVE India Private Limited 206, Metro House 7 Mangaldas Road Pune 411001, Maharashtra	Tel. +91 20 26111054 Fax +91 20 26132337 salespune@seweurodriveindia.com
Indonesia			
Technical Office	Jakarta	SEW-EURODRIVE Pte Ltd. Jakarta Liaison Office, Menara Graha Kencana Jl. Perjuangan No. 88, LT 3 B, Kebun Jeruk, Jakarta 11530	Tel. +62 21 5359066 Fax +62 21 5363686
Ireland			
Sales Service	Dublin	Alperton Engineering Ltd. 48 Moyle Road Dublin Industrial Estate Glasnevin, Dublin 11	Tel. +353 1 830-6277 Fax +353 1 830-6458 info@alperton.ie



Address Directory

Israel			
Sales	Tel-Aviv	Liraz Handasa Ltd. Ahofer Str 34B / 228 58858 Holon	Tel. +972 3 5599511 Fax +972 3 5599512 lirazhandasa@barak-online.net
Italy			
Assembly Sales Service	Milano	SEW-EURODRIVE di R. Blickle & Co.s.a.s. Via Bernini,14 I-20020 Solaro (Milano)	Tel. +39 02 96 9801 Fax +39 02 96 799781 http://www.sew-eurodrive.it sewit@sew-eurodrive.it
Technical Offices	Bologna	SEW-EURODRIVE di R. Blickle & Co.s.a.s. Via Emilia,172 I-40064 Ozzano dell'Emilia (Bo)	Tel. +39 051 796-660 Fax +39 051 796-595
	Caserta	SEW-EURODRIVE di R. Blickle & Co.s.a.s. Viale Carlo III Km. 23,300 I-81020 S. Nicola la Strada (Caserta)	Tel. +39 0823 219011 Fax +39 0823 421414
	Firenze	RIMA Via Einstein, 14 I-50013 Campi Bisenzio (Firenze)	Tel. +39 055 898 58-21 Fax +39 055 898 58-30
	Pescara	SEW-EURODRIVE di R. Blickle & Co.s.a.s. Via Emilia,172 I-40064 Ozzano dell'Emilia (Bo)	Tel. +39 051 796-660 Fax +39 051 796-595
	Torino	SEW-EURODRIVE di R. Blickle & Co.s.a.s. Filiale Torino c.so Unione Sovietica 612/15 - int. C I-11035 Torino	Tel. +39 011 3473780 Fax +39 011 3473783
	Verona	SEW-EURODRIVE di R. Blickle & Co.s.a.s. Via P. Sgulmero, 27/A I-37132 Verona	Tel. +39 045 97-7722 Fax +39 045 97-6079
Ivory Coast			
Sales	Abidjan	SICA Ste industrielle et commerciale pour l'Afrique 165, Bld de Marseille B.P. 2323, Abidjan 08	Tel. +225 2579-44 Fax +225 2584-36
Japan			
Assembly Sales Service	Toyoda-cho	SEW-EURODRIVE JAPAN CO., LTD 250-1, Shimoman-no, Iwata Shizuoka 438-0818	Tel. +81 538 373811 Fax +81 538 373814 http://www.sew-eurodrive.co.jp sewjapan@sew-eurodrive.co.jp
Technical Offices	Fukuoka	SEW-EURODRIVE JAPAN CO., LTD. C-go, 5th-floor, Yakuin-Hiruzu-Bldg. 1-5-11, Yakuin, Chuo-ku Fukuoka, 810-0022	Tel. +81 92 713-6955 Fax +81 92 713-6860 sewkyushu@jasmine.ocn.ne.jp
	Osaka	SEW-EURODRIVE JAPAN CO., LTD. B-Space EIRAI Bldg., 3rd Floor 1-6-9 Kyoumachibori, Nishi-ku, Osaka, 550-0003	Tel. +81 6 6444--8330 Fax +81 6 6444--8338 sewosaka@crocus.ocn.ne.jp
	Tokyo	SEW-EURODRIVE JAPAN CO., LTD. Izumi-Bldg. 5 F 3-2-15 Misaki-cho Chiyoda-ku, Tokyo 101-0061	Tel. +81 3 3239-0469 Fax +81 3 3239-0943 sewtokyo@basil.ocn.ne.jp
Korea			
Assembly Sales Service	Ansan-City	SEW-EURODRIVE KOREA CO., LTD. B 601-4, Banweol Industrial Estate Unit 1048-4, Shingil-Dong Ansan 425-120	Tel. +82 31 492-8051 Fax +82 31 492-8056 http://www.sew-korea.co.kr master@sew-korea.co.kr
	Busan	SEW-EURODRIVE KOREA Co., Ltd. No. 1720 - 11, Songjeong - dong Gangseo-ku Busan 618-270	Tel. +82 51 832-0204 Fax +82 51 832-0230 master@sew-korea.co.kr



Korea			
Technical Offices	Daegu	SEW-EURODRIVE KOREA Co., Ltd. No.1108 Sungan officetel l 87-36, Duryu 2-dong, Dalseo-ku Daegu 704-712	Tel. +82 53 650-7111 Fax +82 53 650-7112 sewdaegu@netsgo.com
	DaeJeon	SEW-EURODRIVE KOREA Co., Ltd. No. 2017, Hongin officitel 536-9, Bongmyung-dong, Yusung-ku Daejeon 305-301	Tel. +82 42 828-6461 Fax +82 42 828-6463 sewdaejeon@netsgo.com
	Kwangju	SEW-EURODRIVE KOREA Co., Ltd. 4fl., Shinhyun B/D 96-16 Unam-dong, Buk-ku Kwangju 500-170	Tel. +82 62 511-9172 Fax +82 62 511-9174 sewkwangju@netsgo.com
	Seoul	SEW-EURODRIVE KOREA Co., Ltd. No.1104 Sunkyung officetel 106-4 Kuro 6-dong, Kuro-ku Seoul 152-054	Tel. +82 2 862-8051 Fax +82 2 862-8199 sewseoul@netsgo.com
Latvia			
Sales	Riga	SIA Alas-Kuul Katlakalna 11C LV-1073 Riga	Tel. +371 7139253 Fax +371 7139386 http://www.alas-kuul.com info@alas-kuul.com
Lebanon			
Sales	Beirut	Gabriel Acar & Fils sarl B. P. 80484 Bourj Hammoud, Beirut	Tel. +961 1 4947-86 +961 1 4982-72 +961 3 2745-39 Fax +961 1 4949-71 gacar@beirut.com
Lithuania			
Sales	Alytus	UAB Irseva Naujoji 19 LT-62175 Alytus	Tel. +370 315 79204 Fax +370 315 56175 info@irseva.lt http://www.sew-eurodrive.lt
Luxembourg			
Assembly Sales Service	Brüssel	CARON-VECTOR S.A. Avenue Eiffel 5 B-1300 Wavre	Tel. +32 10 231-311 Fax +32 10 231-336 http://www.caron-vector.be info@caron-vector.be
Malaysia			
Assembly Sales Service	Johore	SEW-EURODRIVE SDN BHD No. 95, Jalan Seroja 39, Taman Johor Jaya 81000 Johor Bahru, Johor West Malaysia	Tel. +60 7 3549409 Fax +60 7 3541404 sales@sew-eurodrive.com.my
Technical Offices	Kota Kinabalu	SEW-EURODRIVE Sdn Bhd (Kota Kinabalu Branch) Lot No. 2, 1st Floor, Inanam Baru Phase III, Miles 5.1 /2, Jalan Tuaran, Inanam 89350 Kota Kinabalu Sabah, Malaysia	Tel. +60 88 424792 Fax +60 88 424807
	Kuala Lumpur	SEW-EURODRIVE Sdn. Bhd. No. 2, Jalan Anggerik Mokara 31/46 Kota Kemuning Seksyen 31 40460 Shah Alam Selangor Darul Ehsan	Tel. +60 3 5229633 Fax +60 3 5229622 sewpjy@po.jaring.my
	Kuching	SEW-EURODRIVE Sdn. Bhd. Lot 268, Section 9 KTL D Lorong 9, Jalan Satok 93400 Kuching, Sarawak East Malaysia	Tel. +60 82 232380 Fax +60 82 242380



Address Directory

Malaysia			
	Penang	SEW-EURODRIVE Sdn. Bhd. No. 38, Jalan Bawal Kimsar Garden 13700 Prai, Penang	Tel. +60 4 3999349 Fax +60 4 3999348 seweurodrive@po.jaring.my
Mexico			
Assembly Sales Service	Queretaro	SEW-EURODRIVE MEXIKO SA DE CV SEM-981118-M93 Tequisquiapan No. 102 Parque Industrial Queretaro C.P. 76220 Queretaro, Mexico	Tel. +52 442 1030-300 Fax +52 442 1030-301 http://www.sew-eurodrive.com.mx scmexico@seweurodrive.com.mx
Morocco			
Sales	Casablanca	Afit 5, rue Emir Abdelkader MA 20300 Casablanca	Tel. +212 22618372 Fax +212 22618351 richard.miekisiak@premium.net.ma
Netherlands			
Assembly Sales Service	Rotterdam	VECTOR Aandrijftechniek B.V. Industrieweg 175 NL-3044 AS Rotterdam Postbus 10085 NL-3004 AB Rotterdam	Tel. +31 10 4463-700 Fax +31 10 4155-552 http://www.vector.nu info@vector.nu
New Zealand			
Assembly Sales Service	Auckland	SEW-EURODRIVE NEW ZEALAND LTD. P.O. Box 58-428 82 Greenmount drive East Tamaki Auckland	Tel. +64 9 2745627 Fax +64 9 2740165 http://www.sew-eurodrive.co.nz sales@sew-eurodrive.co.nz
	Christchurch	SEW-EURODRIVE NEW ZEALAND LTD. 10 Settlers Crescent, Ferrymead Christchurch	Tel. +64 3 384-6251 Fax +64 3 384-6455 sales@sew-eurodrive.co.nz
Technical Office	Palmerston North	SEW-EURODRIVE NEW ZEALAND LTD. C/-Grant Shearman, RD 5, Aronui Road Palmerston North	Tel. +64 6 355-2165 Fax +64 6 355-2316 sales@sew-eurodrive.co.nz
Norway			
Assembly Sales Service	Moss	SEW-EURODRIVE A/S Solgaard skog 71 N-1599 Moss	Tel. +47 69 241-020 Fax +47 69 241-040 http://www.sew-eurodrive.no sew@sew-eurodrive.no
Pakistan			
Technical Office	Karachi	SEW-EURODRIVE Pte. Ltd. Karachi Liaison Office A/3, 1st Floor, Central Commercial Area Sultan Ahmed Shah Road Block 7/8, K.C.H.S. Union Ltd., Karachi	Tel. +92 21 4529369 Fax +92 21 4547365 seweurodrive@cyber.net.pk
Peru			
Assembly Sales Service	Lima	SEW DEL PERU MOTORES REDUCTORES S.A.C. Los Calderos, 120-124 Urbanizacion Industrial Vulcano, ATE, Lima	Tel. +51 1 3495280 Fax +51 1 3493002 http://www.sew-eurodrive.com.pe sewperu@sew-eurodrive.com.pe
Philippines			
Technical Office	Manila	SEW-EURODRIVE Pte Ltd Manila Liaison Office Suite 110, Ground Floor Comfoods Building Senator Gil Puyat Avenue 1200 Makati City	Tel. +63 2 894275254 Fax +63 2 8942744 sewmla@i-next.net



Poland			
Assembly Sales Service	Lodz	SEW-EURODRIVE Polska Sp.z.o.o. ul. Techniczna 5 PL-92-518 Lodz	Tel. +48 42 67710-90 Fax +48 42 67710-99 http://www.sew-eurodrive.pl sew@sew-eurodrive.pl
Technical Office	Katowice	SEW-EURODRIVE Polska Sp.z.o.o. ul. Nad Jeziorem 87 PL-43-100 Tychy	Tel. +48 32 2175026 + 32 2175027 Fax +48 32 2277910
	Bydgoszcz	SEW-EURODRIVE Polska Sp.z.o.o. ul. Fordonska 246 PL-85-959 Bydgoszcz	Tel. +48 52 3606590 Fax +48 52 3606591
	Szczecinek	SEW-EURODRIVE Polska Sp.z.o.o. ul. Mickiewicza 2 pok. 36 PL-78-400 Szczecinek	Tel. +48 94 3728820 Fax +48 94 3728821
Portugal			
Assembly Sales Service	Coimbra	SEW-EURODRIVE, LDA. Apartado 15 P-3050-901 Mealhada	Tel. +351 231 20 9670 Fax +351 231 20 3685 http://www.sew-eurodrive.pt infosew@sew-eurodrive.pt
Technical Offices	Lisboa	Tertir Edifício Lisboa Gabinete 119 P-2615 Alverca do Ribatejo	Tel. +351 21 958-0198 Fax +351 21 958-0245 esc.lisboa@sew-eurodrive.pt
	Porto	Av. D. Afonso Henriques, 1196 - 1º - sala 102 Edifício ACIA P- 4450-016 Matosinhos	Tel. +351 229 350 383 Fax +351 229 350 384 MobilTel. +351 9 332559110 esc.porto@sew-eurodrive.pt
Romania			
Sales Service	Bucuresti	Sialco Trading SRL str. Madrid nr.4 011785 Bucuresti	Tel. +40 21 230-1328 Fax +40 21 230-7170 sialco@sialco.ro
Russia			
Assembly Sales Service	St. Petersburg	ZAO SEW-EURODRIVE P.O. Box 36 195220 St. Petersburg Russia	Tel. +7 812 3332522 +7 812 5357142 Fax +7 812 3332523 http://www.sew-eurodrive.ru sew@sew-eurodrive.ru
Technical Office	Moskau	ZAO SEW-EURODRIVE RUS-107023 Moskau	Tel. +7 495 9337090 Fax +7 495 9337094 mso@sew-eurodrive.ru
	Novosibirsk	ZAO SEW-EURODRIVE pr. K Marksa, d.30 RUS-630087 Novosibirsk	Tel. +7 383 3350200 Fax +7 383 3462544 nso@sew-eurodrive.ru
	Togliatti	ZAO SEW-EURODRIVE Sportivnaya Str. 4B, office 2 Samarskaya obl. RUS-445057 Togliatti	Tel. +7 8482 710529 Fax +7 8482 810590
Senegal			
Sales	Dakar	SENEMECA Mécanique Générale Km 8, Route de Rufisque B.P. 3251, Dakar	Tel. +221 849 47-70 Fax +221 849 47-71 senemeca@sentoo.sn
Serbia and Montenegro			
Sales	Beograd	DIPAR d.o.o. Ustanicka 128a PC Košum, IV floor SCG-11000 Beograd	Tel. +381 11 347 3244 / +381 11 288 0393 Fax +381 11 347 1337 dipar@yubc.net



Address Directory

Singapore			
Assembly Sales Service	Singapore	SEW-EURODRIVE PTE. LTD. No 9, Tuas Drive 2 Jurong Industrial Estate Singapore 638644	Tel. +65 68621701 Fax +65 68612827 http://www.sew-eurodrive.com.sg sewsingapore@sew-eurodrive.com
Slovakia			
Sales	Bratislava	SEW-Eurodrive SK s.r.o. Rybnicna 40 SK-83107 Bratislava	Tel. +421 2 49595201 Fax +421 2 49595200 http://www.sew.sk sew@sew-eurodrive.sk
	Zilina	SEW-Eurodrive SK s.r.o. ul. Vojtecha Spanyola 33 SK-010 01 Zilina	Tel. +421 41 700 2513 Fax +421 41 700 2514 sew@sew-eurodrive.sk
	Banská Bystrica	SEW-Eurodrive SK s.r.o. Rudlovska cesta 85 SK-97411 Banská Bystrica	Tel. +421 48 414 6564 Fax +421 48 414 6566 sew@sew-eurodrive.sk
Slovenia			
Sales Service	Celje	Pakman - Pogonska Tehnika d.o.o. Ul. XIV. divizije 14 SLO - 3000 Celje	Tel. +386 3 490 83-20 Fax +386 3 490 83-21 pakman@siol.net
South Africa			
Assembly Sales Service	Johannesburg	SEW-EURODRIVE (PROPRIETARY) LIMITED Eurodrive House Cnr. Adcock Ingram and Aerodrome Roads Aeroton Ext. 2 Johannesburg 2013 P.O.Box 90004 Bertsham 2013	Tel. +27 11 248-7000 Fax +27 11 494-3104 http://www.sew.co.za dross@sew.co.za
	Capetown	SEW-EURODRIVE (PROPRIETARY) LIMITED Rainbow Park Cnr. Racecourse & Omuramba Road Montague Gardens Cape Town P.O.Box 36556 Chempet 7442 Cape Town	Tel. +27 21 552-9820 Fax +27 21 552-9830 Telex 576 062 dswanepoel@sew.co.za
	Durban	SEW-EURODRIVE (PROPRIETARY) LIMITED 2 Monaceo Place Pinetown Durban P.O. Box 10433, Ashwood 3605	Tel. +27 31 700-3451 Fax +27 31 700-3847 dtait@sew.co.za
	Nelspruit	SEW-EURODRIVE (PTY) LTD. 7 Christie Crescent Vintonia P.O.Box 1942 Nelspruit 1200	Tel. +27 13 752-8007 Fax +27 13 752-8008 robermeyer@sew.co.za
	Technical Offices	Port Elizabeth	SEW-EURODRIVE PTY LTD. 5 b Linsay Road Neave Township 6000 Port Elizabeth
Richards Bay		SEW-EURODRIVE PTY LTD. 25 Eagle Industrial Park Alton Richards Bay P.O. Box 458 Richards Bay 3900	Tel. +27 35 797-3805 Fax +27 35 797-3819 dtait@sew.co.za
Spain			
Assembly Sales Service	Bilbao	SEW-EURODRIVE ESPAÑA, S.L. Parque Tecnológico, Edificio, 302 E-48170 Zamudio (Vizcaya)	Tel. +34 94 43184-70 Fax +34 94 43184-71 http://www.sew-eurodrive.es sew.spain@sew-eurodrive.es
Technical Offices	Barcelona	Delegación Barcelona Avenida Francesc Maciá 40-44 Oficina 3.1 E-08206 Sabadell (Barcelona)	Tel. +34 93 7162200 Fax +34 93 7233007



Spain			
	Lugo	Delegación Noroeste Apartado, 1003 E-27080 Lugo	Tel. +34 639 403348 Fax +34 982 202934
	Madrid	Delegación Madrid Gran Vía. 48-2° A-D E-28220 Majadahonda (Madrid)	Tel. +34 91 6342250 Fax +34 91 6340899
Sri Lanka			
Sales	Colombo	SM International (Pte) Ltd 254, Galle Raod Colombo 4, Sri Lanka	Tel. +94 1 2584887 Fax +94 1 2582981
Sweden			
Assembly Sales Service	Jönköping	SEW-EURODRIVE AB Gnejsvägen 6-8 S-55303 Jönköping Box 3100 S-55003 Jönköping	Tel. +46 36 3442-00 Fax +46 36 3442-80 http://www.sew-eurodrive.se info@sew-eurodrive.se
Technical Offices	Göteborg	SEW-EURODRIVE AB Gustaf Werners gata 8 S-42131 Västra Frölunda	Tel. +46 31 70968-80 Fax +46 31 70968-93
	Malmö	SEW-EURODRIVE AB Borrgatan 5 S-21124 Malmö	Tel. +46 40 68064-80 Fax +46 40 68064-93
	Stockholm	SEW-EURODRIVE AB Björkholmsvägen 10 S-14125 Huddinge	Tel. +46 8 44986-80 Fax +46 8 44986-93
	Skellefteå	SEW-EURODRIVE AB Trädgårdsgatan 8 S-93131 Skellefteå	Tel. +46 910 7153-80 Fax +46 910 7153-93
Switzerland			
Assembly Sales Service	Basel	Alfred Imhof A.G. Jurastrasse 10 CH-4142 Münchenstein bei Basel	Tel. +41 61 417 1717 Fax +41 61 417 1700 http://www.imhof-sew.ch info@imhof-sew.ch
Technical Offices	Rhaetian Switzerland	André Gerber Es Perreyres CH-1436 Chamblon	Tel. +41 24 445 3850 Fax +41 24 445 4887
	Bern / Solothurn	Rudolf Bühler Muntersweg 5 CH-2540 Grenchen	Tel. +41 32 652 2339 Fax +41 32 652 2331
	Central Switzerland and Ticino	Beat Lütolf Baumacher 11 CH-6244 Nebikon	Tel. +41 62 756 4780 Fax +41 62 756 4786
	Zürich	René Rothenbühler Nörgelbach 7 CH-8493 Saland	Tel. +41 52 386 3150 Fax +41 52 386 3213
	Bodensee and East Switzerland	Markus Künzle Eichweg 4 CH-9403 Goldbach	Tel. +41 71 845 2808 Fax +41 71 845 2809
Taiwan (R.O.C.)			
Sales	Nan Tou	Ting Shou Trading Co., Ltd. No. 55 Kung Yeh N. Road Industrial District Nan Tou 540	Tel. +886 49 255353 Fax +886 49 257878
	Taipei	Ting Shou Trading Co., Ltd. 6F-3, No. 267, Sec. 2 Tung Hwa South Road, Taipei	Tel. +886 2 27383535 Fax +886 2 27368268 Telex 27 245 sewtwn@ms63.hinet.net



Address Directory

Thailand			
Assembly Sales Service	Chonburi	SEW-EURODRIVE (Thailand) Ltd. 700/456, Moo.7, Donhuaroh Muang Chonburi 20000	Tel. +66 38 454281 Fax +66 38 454288 sewthailand@sew-eurodrive.com
Technical Offices	Bangkok	SEW-EURODRIVE PTE LTD Bangkok Liaison Office 6th floor, TPS Building 1023, Phattanakarn Road Klongtan, Phrakanong, Bangkok,10110	Tel. +66 2 7178149 Fax +66 2 7178152 sewthailand@sew-eurodrive.com
	Hadyai	SEW-EURODRIVE (Thailand) Ltd. Hadyai Country Home Condominium 59/101 Soi.17/1 Rachas-Utid Road. Hadyai, Songkhla 90110	Tel. +66 74 359441 Fax +66 74 359442 sewhdy@ksc.th.com
	Khonkaen	SEW-EURODRIVE (Thailand) Ltd. 4th Floor, Kaow-U-HA MOTOR Bldg, 359/2, Mitraphab Road. Muang District Khonkaen 40000	Tel. +66 43 225745 Fax +66 43 324871 sewkk@cscoms.com
	Lampang	SEW-EURODRIVE (Thailand) Ltd. 264 Chatchai Road, sob-tuy, Muang, Lampang 52100	Tel. +66 54 310241 Fax +66 54 310242 sewthailand@sew-eurodrive.com
Tunisia			
Sales	Tunis	T. M.S. Technic Marketing Service 5, Rue El Houdaibiah 1000 Tunis	Tel. +216 71 4340-64 + 71 4320-29 Fax +216 71 4329-76 tms@tms.com.tn
Turkey			
Assembly Sales Service	Istanbul	SEW-EURODRIVE Hareket Sistemleri San. ve Tic. Ltd. Sti. Bagdat Cad. Koruma Cikmazi No. 3 TR-34846 Maltepe ISTANBUL	Tel. +90 216 4419163 / 164 3838014/15 Fax +90 216 3055867 http://www.sew-eurodrive.com.tr sew@sew-eurodrive.com.tr
Technical Offices	Ankara	SEW-EURODRIVE Hareket Sistemleri San. ve Tic. Ltd. Sti. Özcelik Is Merkezi, 14. Sok, No. 4/42 TR-06370 Ostim/Ankara	Tel. +90 312 3853390 / +90 312 3544715 / +90 312 3546109 Fax +90 312 3853258
	Bursa	SEW-EURODRIVE Hareket Sistemleri San. ve Tic. Ltd. Sti. Besevler Küçük Sanayi Parkoop Parçacilar Sitesi 48. Sokak No. 47 TR Nilüfer/Bursa	Tel. +90 224 443 4556 Fax +90 224 443 4558
	Izmir	SEW-EURODRIVE Hareket Sistemleri San. ve Tic. Ltd. Sti. 1203/11 Sok. No. 4/613 Hasan Atli Is Merkezi TR-35110 Yenisehir-Izmir	Tel. +90 232 4696264 Fax +90 232 4336105
Ukraine			
Sales Service	Dnepropetrovsk	SEW-EURODRIVE Str. Rabochaja 23-B, Office 409 49008 Dnepropetrovsk	Tel. +380 56 370 3211 Fax +380 56 372 2078 http://www.sew-eurodrive.ua sew@sew-eurodrive.ua
Sales	Kiev	SEW-EURODRIVE GmbH S. Oleynika str. 21 02068 Kiev	Tel. +380 44 503 95 77 Fax +380 44 503 95 78 kso@sew-eurodrive.ua
Uruguay			
Sales	Montevideo	SEW-EURODRIVE Uruguay, S. A. German Barbato 1526 CP 11200 Montevideo	Tel. +598 2 90181-89 Fax +598 2 90181-88 sewuy@sew-eurodrive.com.uy



USA			
Production Assembly Sales Service	Greenville	SEW-EURODRIVE INC. 1295 Old Spartanburg Highway P.O. Box 518 Lyman, S.C. 29365	Tel. +1 864 439-7537 Fax Sales +1 864 439-7830 Fax Manuf. +1 864 439-9948 Fax Ass. +1 864 439-0566 Telex 805 550 http://www.seweurodrive.com cslyman@seweurodrive.com
Assembly Sales Service	San Francisco	SEW-EURODRIVE INC. 30599 San Antonio St. Hayward, California 94544-7101	Tel. +1 510 487-3560 Fax +1 510 487-6381 cshayward@seweurodrive.com
	Philadelphia/PA	SEW-EURODRIVE INC. Pureland Ind. Complex 2107 High Hill Road, P.O. Box 481 Bridgeport, New Jersey 08014	Tel. +1 856 467-2277 Fax +1 856 845-3179 csbridgeport@seweurodrive.com
	Dayton	SEW-EURODRIVE INC. 2001 West Main Street Troy, Ohio 45373	Tel. +1 937 335-0036 Fax +1 937 440-3799 cstroy@seweurodrive.com
	Dallas	SEW-EURODRIVE INC. 3950 Platinum Way Dallas, Texas 75237	Tel. +1 214 330-4824 Fax +1 214 330-4724 csdallas@seweurodrive.com
Additional addresses for service in the USA provided on request!			
Venezuela			
Assembly Sales Service	Valencia	SEW-EURODRIVE Venezuela S.A. Av. Norte Sur No. 3, Galpon 84-319 Zona Industrial Municipal Norte Valencia, Estado Carabobo	Tel. +58 241 832-9804 Fax +58 241 838-6275 http://www.sew-eurodrive.com.ve sewventas@cantv.net sewfinanzas@cantv.net

How we're driving the world

With people who think fast and develop the future with you.



With a global presence that offers responsive and reliable solutions. Anywhere.

With a worldwide service network that is always close at hand.

With drives and controls that automatically improve your productivity.

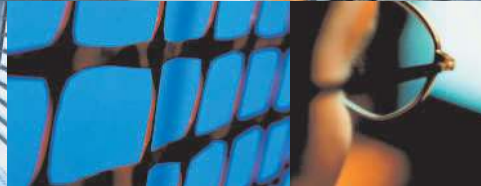

With innovative technology that solves tomorrow's problems today.

With comprehensive knowledge in virtually every branch of industry today.



With online information and software updates, via the Internet, available around the clock.

With uncompromising quality that reduces the cost and complexity of daily operations.



SEW-EURODRIVE
Driving the world



SEW
EURODRIVE

SEW-EURODRIVE GmbH & Co KG
P.O. Box 3023 · D-76642 Bruchsal / Germany
Phone +49 7251 75-0 · Fax +49 7251 75-1970
sew@sew-eurodrive.com

→ www.sew-eurodrive.com