

THIS COPY IS PROVIDED ON A RESTRICTED BASIS AND IS NOT TO BE USED IN ANY WAY DETRIMENTAL TO THE INTERESTS OF PANDUIT CORP.

NOTES:

1. TERMINATED AT EACH END WITH HDMI™ TYPE A MALE CONNECTOR WITH 30AWG AWM CABLE WITH ETHERNET
2. MATERIAL:  
CONNECTOR: PVC  
CONNECTOR: GOLD FLASH OVER NICKEL

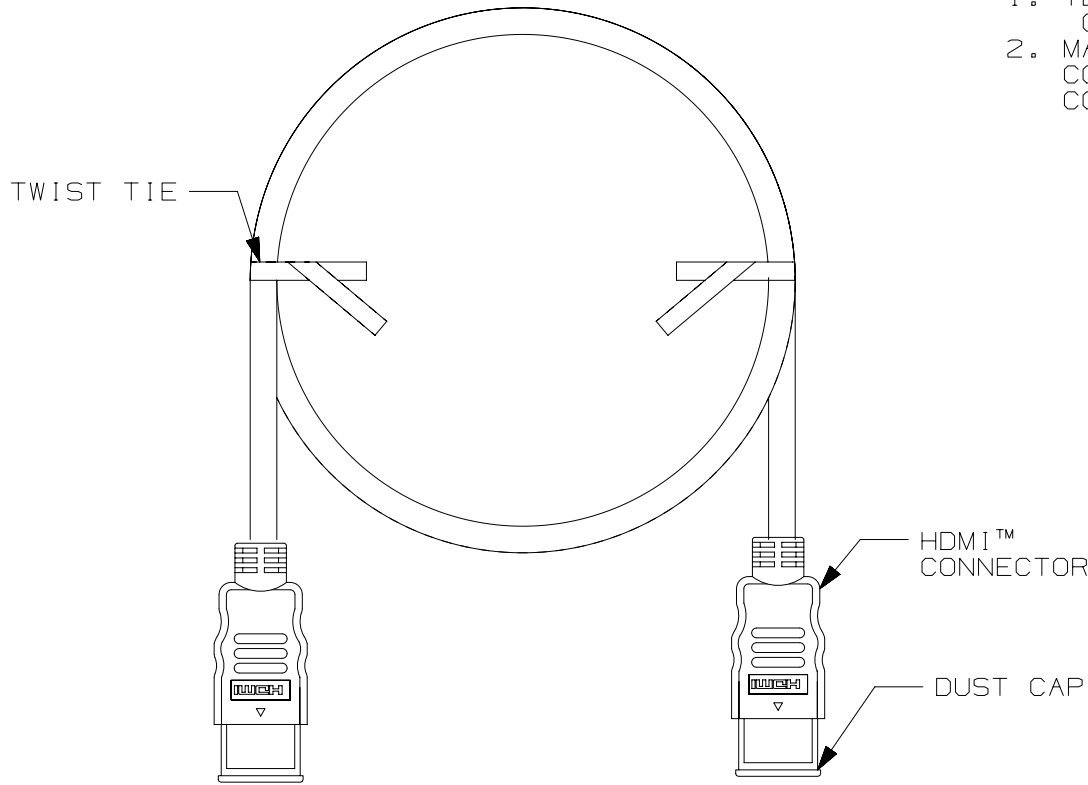

TABLE 1

PART NUMBER	LENGTH	TOLERANCE	CABLE SIZE	CABLE SIZE
HDMI1MBL	1M	±30	30AWG	30AWG
HDMI2MBL	2M	±50	28AWG	28AWG
HDMI4MBL	4M	±100	28AWG	28AWG
HDMI1MWH	1M	±30	30AWG	30AWG
HDMI2MWH	2M	±50	28AWG	28AWG
HDMI4MWH	4M	±100	28AWG	28AWG

PART NUMBER		SEE TABLE 1						
TITLE								
<b>PREMIUM HIGH SPEED HDMI™ CABLE WITH ETHERNET TYPE A MALE TO TYPE A MALE</b>								
CUSTOMER DRAWING								
ITEM REVISION NAME		00039EBA/00.PRT						
DATASET FILE NAME		00039EBA_DC01/00A.PRT						
			MATERIAL:					
			SEE NOTE 2					
			DRAWING NUMBER:					
			00039EBA-01					
DRAWN BY		DATE	CHK	SCALE	 THIRD ANGLE PROJECTION			
TA		2-19-18	ROJC	NONE				
REV		DATE	BY	CHK	APR	DESCRIPTION	ECN	00039EBA-01
SHT 1 OF 1		A						