

Service
Service
Service



Service Manual

TABLE OF CONTENTS

	Page
Location of PCBs & Version Variations	1-2
Technical Specifications	1-3
Measurement setup	1-4
Service Aids, Safety Instruction, etc	1-5
Preparations & Controls	1-7
Disassembly Instructions & Service positions	2
Service Test Programs & DEMO mode	3
Set Block diagram	4
Set Wiring diagram	5
Front Board	6
Mains Board	8
ECO-MTF Module	9
3CDC-LC-MB Module	10
Combi Board	11
Set Mechanical Exploded View & Parts List	12



© Copyright 2002 Philips Consumer Electronics B.V. Eindhoven, The Netherlands
All rights reserved. No part of this publication may be reproduced, stored in a retrieval system or transmitted, in any form or by any means, electronic, mechanical, photocopying, or otherwise without the prior permission of Philips.

Published by SL 0345 Service Audio Printed in The Netherlands Subject to modification



3140 785 32780

Version 1.0



PHILIPS

SPECIFICATIONS

GENERAL:

Mains voltage	: 110-127V/220-240V Switchable
Mains frequency	: 50/60Hz
Power consumption	: < 70W Active < 20W at Standby
Clock accuracy	: < 4 seconds per day
Dimension centre unit	: 265 x 310 x 365mm

TUNER:

FM

Tuning range	: 87.5-108MHz
Grid	: 100kHz
IF frequency	: 10.7MHz \pm 20kHz
Aerial input	: 75 Ω coaxial
Sensitivity at 26dB S/N	: < 7 μ V
Selectivity at 600kHz bandwidth	: > 25dB
IF rejection	: > 60dB
Image rejection	: > 25dB
Distortion at RF=1mV, dev. 75kHz	: < 3%
-3dB Limiting point	: < 8 μ V
Crosstalk at RF=1mV, dev. 40kHz	: > 18dB

MW

Tuning range	: 531-1602kHz or 530-1700kHz
Grid	: 9kHz or 10kHz
IF frequency	: 450kHz \pm 1kHz
Aerial input	: Frame aerial
Sensitivity at 26dB S/N	: < 4.4mV/M
Selectivity at 18kHz bandwidth	: > 18dB
IF rejection	: > 45dB
Image rejection	: > 28dB
Distortion at RF=50mV, m=80%	: < 5%

AMPLIFIER:

Output power	: 2 x 40W ¹⁾ RMS
Frequency response within -3dB	: 50Hz-15kHz
Dynamic Bass Boost	: DBB ON, DBB 1, DBB 2, DBB 3 ²⁾
Digital Sound Control	: Jazz, Techno, Optimal, Rock ²⁾
Headphone output at 32 Ω	: 15mW \pm 2dB
Input sensitivity, R _s = 600 Ω	
Aux / CDR	: 500mV / 1.0V
Mic	: {3.5mV}

CASSETTE RECORDER:

Number of track	: 2 x 2 stereo
Tape speed	: 4.76 cm/sec +2.5/-1.5%
Wow and flutter	: < 0.35% DIN
Fast-wind/rewind time C60	: 130 sec
Bias system	: 75kHz \pm 5kHz
Rec/Pb frequency response within 8dB	: 80Hz - 12.5kHz
Signal to noise ratio	Type I : > 48dBA

COMPACT DISC:

Measurement done at output conn. of the CDC module.	
Frequency response within \pm 1.5dB	: 20Hz - 20kHz
Output level (in V _{rms})	: 550mV \pm 2dB, R _{out} = 100 Ω
Signal/Noise ratio (A-weighted)	: > 80dBA
Distortion at 1kHz	: < 0.003%
Channel unbalance at 1kHz	: \pm 1dB
Channel separation at 1kHz	: > 60dB
De-emphasis	: 0 or 15/50 mS (Switched by subcode on the disc)

¹⁾ 6 Ω , 1kHz, 10% THD

²⁾ Frequency response in each setting is software controlled.

MEASUREMENT SETUP

Tuner FM

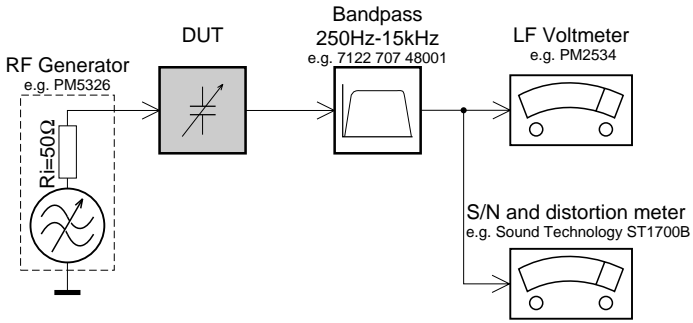

Use a bandpass filter to eliminate hum (50Hz, 100Hz) and disturbance from the pilotone (19kHz, 38kHz).

Tuner AM (MW,LW)

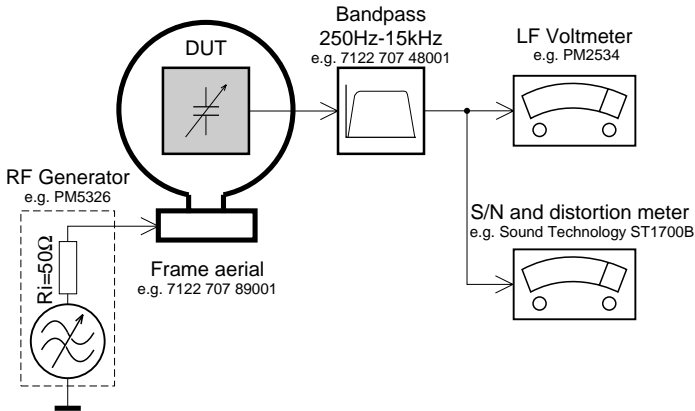

To avoid atmospheric interference all AM-measurements have to be carried out in a Faraday's cage. Use a bandpass filter (or at least a high pass filter with 250Hz) to eliminate hum (50Hz, 100Hz).

CD

Use Audio Signal Disc SBC429 4822 397 30184 (replaces test disc 3)

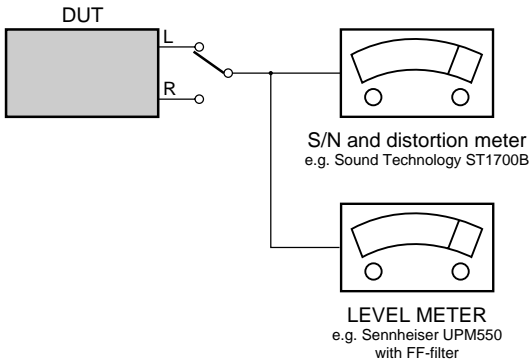

Recorder

Use Universal Test Cassette **CrO2** SBC419 4822 397 30069 or Universal Test Cassette **Fe** SBC420 4822 397 30071

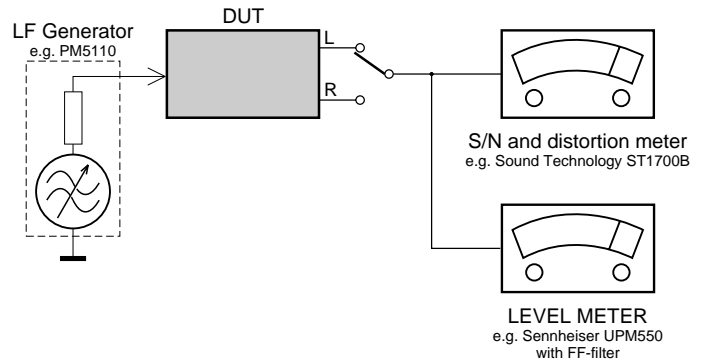

SERVICE AIDS

Service Tools:

Universal Torx driver holder	4822 395 91019
Torx bit T10 150mm	4822 395 50456
Torx driver set T6 - T20	4822 395 50145
Torx driver T10 extended	4822 395 50423

Cassette:

SBC419 Test cassette CrO2	4822 397 30069
SBC420 Test cassette Fe	4822 397 30071
MTT150 Dolby level 200nWb/M	4822 397 30271

Compact Disc:

SBC426/426A Test disc 5 + 5A	4822 397 30096
SBC442 Audio Burn-in Test disc 1kHz	4822 397 30155
SBC429 Audio Signals disc	4822 397 30184
Dolby Pro-logic Test Disc	4822 395 10216

ESD Equipment:

Anti-static table mat - large 1200x650x1.25mm ...	4822 466 10953
Anti-static table mat - small 600x650x1.25mm	4822 466 10958
Anti-static wristband	4822 395 10223
Connector box (1M Ω)	4822 320 11307
Extension cable (to connect wristband to conn. box)	4822 320 11305
Connecting cable (to connect table mat to conn. box)	4822 320 11306
Earth cable (to connect product to mat or box)	4822 320 11308
Complete kit ESD3 (combining all above products)	4822 320 10671
Wristband tester	4822 344 13999

HANDLING CHIP COMPONENTS

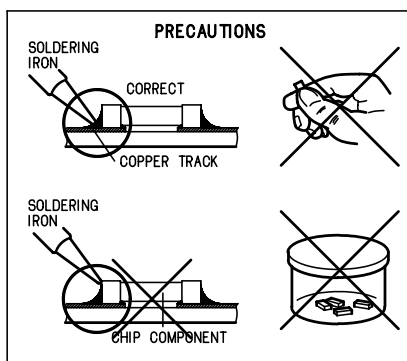
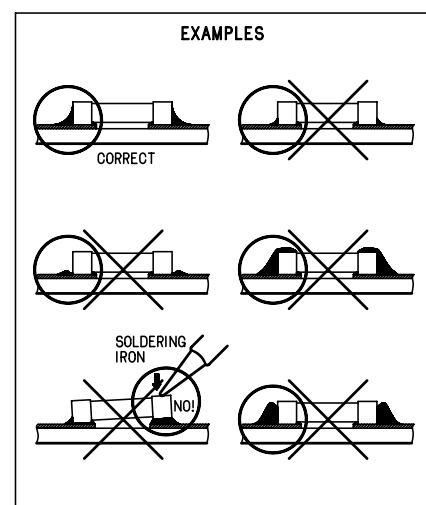
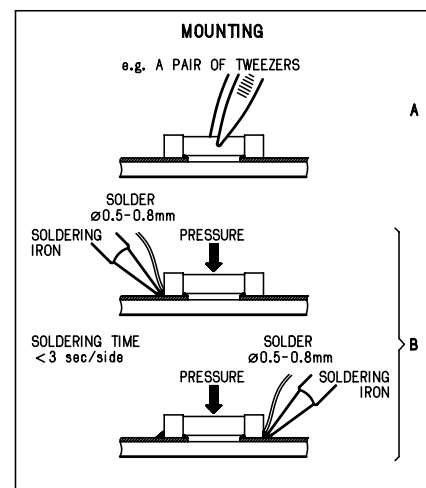
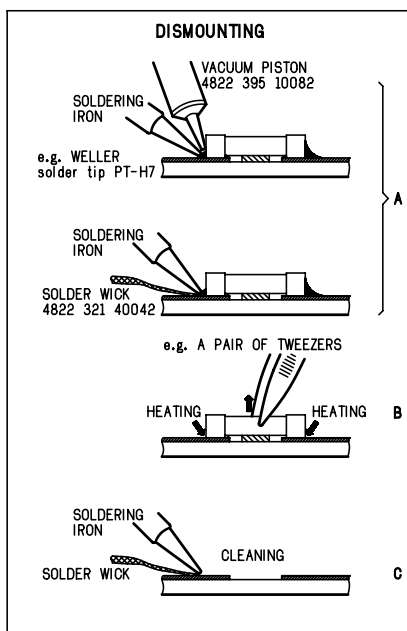
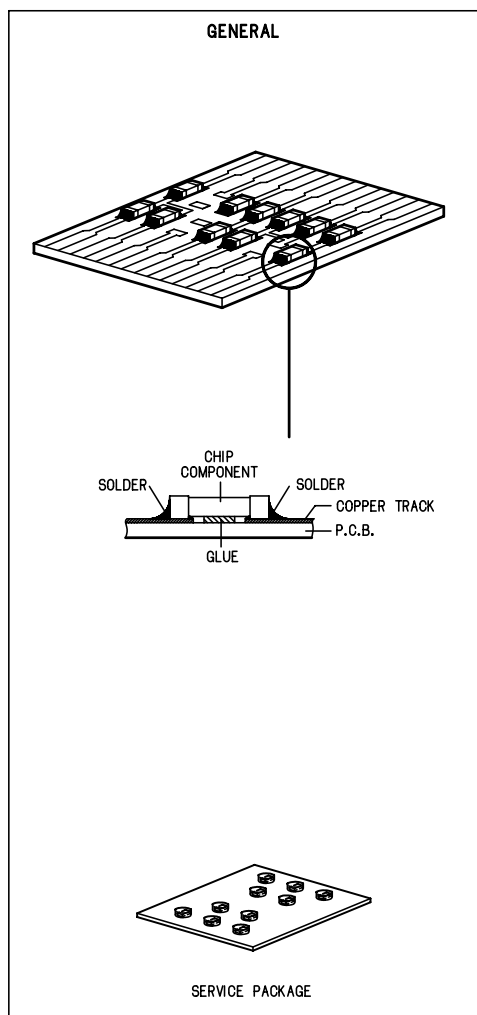

(GB) WARNING

All ICs and many other semi-conductors are susceptible to electrostatic discharges (ESD). Careless handling during repair can reduce life drastically.

When repairing, make sure that you are connected with the same potential as the mass of the set via a wrist wrap with resistance. Keep components and tools also at this potential.

ESD**(NL) WAARSCHUWING**

Alle IC's en vele andere halfgeleiders zijn gevoelig voor electrostatische ontladingen (ESD).

Onzorgvuldig behandelen tijdens reparatie kan de levensduur drastisch doen verminderen.

Zorg ervoor dat u tijdens reparatie via een polsband met weerstand verbonden bent met hetzelfde potentiaal als de massa van het apparaat.

Houd componenten en hulpmiddelen ook op ditzelfde potentiaal.

(F) ATTENTION

Tous les IC et beaucoup d'autres semi-conducteurs sont sensibles aux décharges statiques (ESD).

Leur longévité pourrait être considérablement écourtée par le fait qu'aucune précaution n'est prise à leur manipulation.

Lors de réparations, s'assurer de bien être relié au même potentiel que la masse de l'appareil et enfilez le bracelet serti d'une résistance de sécurité.

Veiller à ce que les composants ainsi que les outils que l'on utilise soient également à ce potentiel.

(D) WARNUNG

Alle ICs und viele andere Halbleiter sind empfindlich gegenüber elektrostatischen Entladungen (ESD).

Unvorsichtige Behandlung im Reparaturfall kann die Lebensdauer drastisch reduzieren.

Veranlassen Sie, dass Sie im Reparaturfall über ein Pulsarmband mit Widerstand verbunden sind mit dem gleichen Potential wie die Masse des Gerätes.

Bauteile und Hilfsmittel auch auf dieses gleiche Potential halten.

(I) AVVERTIMENTO

Tutti IC e parecchi semi-conduttori sono sensibili alle scariche statiche (ESD).

La loro longevità potrebbe essere fortemente ridotta in caso di non osservazione della più grande cauzione alla loro manipolazione.

Durante le riparazioni occorre quindi essere collegato allo stesso potenziale che quello della massa dell'apparecchio tramite un braccialetto a resistenza.

Assicurarsi che i componenti e anche gli utensili con quali si lavora siano anche a questo potenziale.

(GB)

Safety regulations require that the set be restored to its original condition and that parts which are identical with those specified, be used.

"Pour votre sécurité, ces documents doivent être utilisés par des spécialistes agréés, seuls habilités à réparer votre appareil en panne".

(NL)

Veiligheidsbepalingen vereisen, dat het apparaat bij reparatie in zijn oorspronkelijke toestand wordt teruggebracht en dat onderdelen, identiek aan de gespecificeerde, worden toegepast.

**(F)**

Les normes de sécurité exigent que l'appareil soit remis à l'état d'origine et que soient utilisées les pièces de rechange identiques à celles spécifiées.

(GB) Warning !

Invisible laser radiation when open.
Avoid direct exposure to beam.

(D)

Bei jeder Reparatur sind die geltenden Sicherheitsvorschriften zu beachten. Der Originalzustand des Geräts darf nicht verändert werden; für Reparaturen sind Original-Ersatzteile zu verwenden.

(S) Varning !

Osynlig laserstrålning när apparaten är öppnad och spärren är urkopplad. Betrakta ej strålen.

(I)

Le norme di sicurezza esigono che l'apparecchio venga rimesso nelle condizioni originali e che siano utilizzati i pezzi di ricambio identici a quelli specificati.

(SF) Varoitus !

Avatussa laitteessa ja suojalukituksen ohitettaessa olet alltiina näkymättömälle laserisäteilylle. Älä katso säteeseen!

(DK) Advarse !

Usynlig laserstrålning ved åbning når sikkerhedsafbrydere er ude af funktion. Undgå udsættelse for stråling.

"After servicing and before returning set to customer perform a leakage current measurement test from all exposed metal parts to earth ground to assure no shock hazard exist. The leakage current must not exceed 0.5mA."

PREPARATIONS AND CONTROLS

Preparations

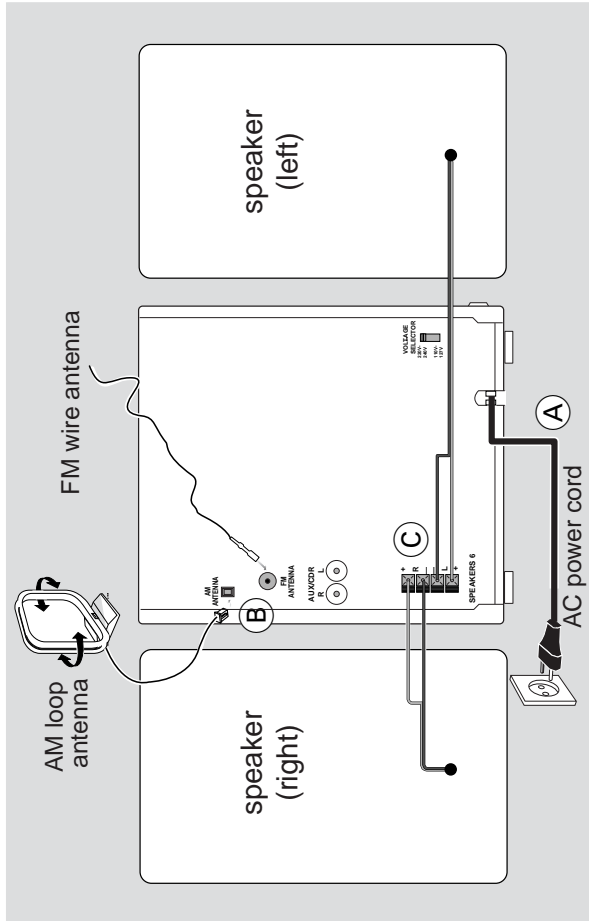

FM Antenna



For better FM stereo reception, connect an outdoor FM antenna to the FM ANTENNA terminal.

Speakers Connection

Connect the speaker wires to the SPEAKERS terminals, right speaker to "R" and left speaker to "L", coloured (marked) wire to "+" and black (unmarked) wire to "-".

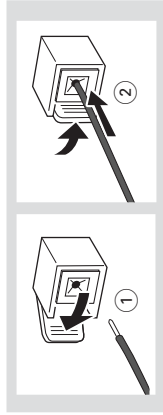

Rear connections

The type plate is located at the rear of the system.

A Power

- Before connecting the AC power cord to the wall outlet, ensure that the following are done:
 - If your system is equipped with a Voltage Selector, set the VOLTAGE SELECTOR to the local power line voltage.
 - All other connections have been made.

WARNING!

- For optimal performance, use only the original power cable.
- Never make or change any connections with the power switched on.

To avoid overheating of the system, a safety circuit has been built in. Therefore, your system may switch to Standby mode automatically under extreme conditions. If this happens, let the system cool down before reusing it (not available for all versions).

B Antennas Connection

Connect the supplied AM loop antenna and FM antenna to the respective terminals. Adjust the position of the antenna for optimal reception.

AM Antenna

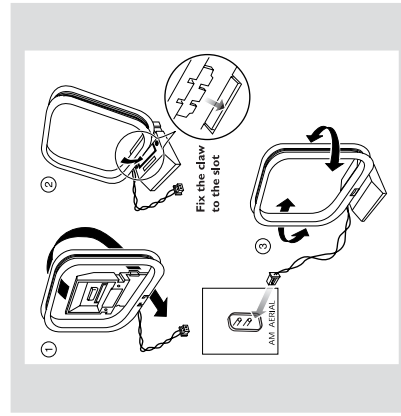

Position the antenna as far as possible from a TV, VCR or other radiation source.

Preparations

Optional connection

The optional equipment and connecting cords are not supplied. Refer to the operating instructions of the connected equipment for details.

Connecting other equipment to your system

Use a cinch cable to connect **AUX/CDR IN** to the analogue audio out terminals of an external equipment (TV/VCR, Laser Disc player, DVD player or CD Recorder).

Note:

- If you are connecting equipment with a mono output (a single audio out terminal), connect it to the AUX/CDR IN left terminal. Alternatively, you can use a "single to double" cinch cable (the output sound still remain mono).

Inserting batteries into the remote control

Insert two batteries type R03 or AAA (not supplied) into the remote control with the correct polarity as indicated by the "+" and "-" symbols inside the battery compartment.

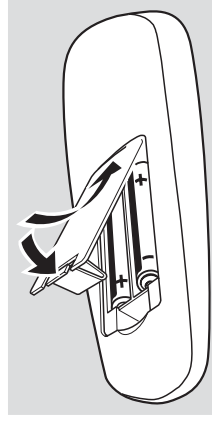



CAUTION!

- Remove batteries if they are exhausted or will not be used for a long time.
- Do not use old and new or different types of batteries in combination.
- Batteries contain chemical substances, so they should be disposed off properly.

PREPARATIONS AND CONTROLS

Controls

- (16) **Mode Selection**
PLAY•PAUSE ▶ II
 for CD to start or interrupt playback.
 for Plug & Play... (on the system only) to initiate and start plug & play mode.
- SEARCH•TUNING ◀◀ ▶▶**
 for CD to search backward/forward.
 for Tuner to tune to a lower or higher radio frequency.
 for Clock (on the system only) to set the hour.
- STOP•CLEAR / DEMO STOP ■**
 for CD to stop playback or to clear a programme.
 for Tuner (on the system only) to stop programming or to erase a selected preset.
 for Demo (on the system only) to activate/deactivate the demonstration.
 for Clock (on the system only) to exit clock setting or cancel timer.
 for Plug & Play... (on the system only) to exit plug & play mode.
- PREV ◀ / PRESET ▼**
NEXT ▶ / PRESET ▲
 for CD to skip to the beginning of the current, previous, or next track.
 for Tuner to select a preset radio station.
 for Clock (on the system only) to set the minute.
- (17)  to connect headphones.
- (18) **MASTER VOLUME (VOL + / -)**
 - to increase or decrease the volume.
- (19) **Display screen**
 - to view the current status of the system.
- (20) **Disc tray**
- (21) **REPEAT**
 - to playback track(s)/disc(s)/programme repeatedly.
- (22) **SHUFFLE**
 - to playback all available discs and their tracks/programme in random order.
- (23) **MUTE**
 - to interrupt or resume sound reproduction.
 to switch the system to standby mode.
- Notes for remote control:**
 - First, select the source you wish to control by pressing one of the source select keys on the remote control (CD 1/2/3 or TUNER, for example).
 - Then select the desired function (▶, ◀, ▲, ▼, for example).

MAINTENANCE AND TROUBLESHOOTING

Troubleshooting

RADIO RECEPTION

Radio reception is poor.

- If the signal is too weak, adjust the antenna or connect an external antenna for better reception.
- Increase the distance between the Mini HiFi System and your TV or VCR.

TAPE OPERATION/RECORDING

Recording or playback cannot be made.

- Clean deck parts, see "Maintenance".
- Use only NORMAL (IEC I) tape.
- Apply a piece of adhesive tape over the missing tab space.

GENERAL

The system does not react when buttons are pressed.

- Remove and reconnect the AC power plug and switch on the system again.

Sound cannot be heard or is of poor quality.

- Adjust the volume.
- Disconnect the headphones.
- Check that the speakers are connected correctly.
- Check if the stripped speaker wire is clamped.
- Check the speaker connections and location.

The left and right sound outputs are reversed.

- Check the speaker connections and location.

The remote control does not function properly.

- Select the source (CD 1/2/3 or TUNER, for example) before pressing the function button (▲, ◀, ▶, ▼).
- Reduce the distance between the remote control and the system.
- Insert the batteries with their polarities (+/- signs) aligned as indicated.
- Replace the batteries.
- Point the remote control directly towards the IR sensor.

The timer is not working.

- Set the clock correctly.
- Press and hold CLOCK/TIMER to switch on the timer.
- If recording or tape dubbing is in progress, stop recording.

The Clock/Timer setting is erased.

- Power has been interrupted or the power cord has been disconnected. Reset the clock/timer.

The system displays features automatically.

- Press and hold ■ on the system to switch off the demonstration.

Maintenance

Cleaning the Heads and the Tape Paths

To ensure good recording and playback quality, clean the heads (A) and (B), the capstan(s) (C), and pressure roller(s) (D) after every 50 hours of tape operation.

Use a cotton swab slightly moistened with cleaning fluid or alcohol. You also can clean the heads by playing a cleaning tape once.

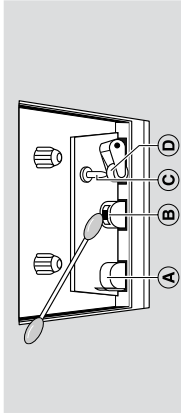

Demagnetising the heads

Use a demagnetising tape available at your dealer.

Cleaning the Cabinet

Use a soft cloth slightly moistened with a mild detergent solution. Do not use a solution containing alcohol, spirits, ammonia or abrasives.

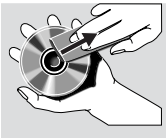

Cleaning Discs

When a disc becomes dirty, clean it with a cleaning cloth. Wipe the disc from the centre out. Do not wipe in circular motion. Do not use solvents such as benzene, thinner, commercially available cleaners, or antistatic spray intended for analogue records.

Cleaning the disc lens

After prolonged use, dirt or dust may accumulate at the disc lens. To ensure good playback quality, clean the disc lens with Philips CD Lens Cleaner or any commercially available cleaner. Follow the instructions supplied with cleaner.

Troubleshooting

WARNING

Under no circumstances should you try to repair the system yourself, as this will invalidate the warranty. Do not open the system as there is a risk of electric shock.

If a fault occurs, first check the points listed below before taking the system for repair. If you are unable to solve a problem by following these hints, consult your dealer or service centre.

Problem

Solution

- | | |
|------------------------------------|--|
| "NO DISC" is displayed. | <ul style="list-style-type: none"> - Insert a disc. - Check if the disc is inserted upside down. - Wait until the moisture condensation at the lens has cleared. - Replace or clean the disc, see "Maintenance". |
| "DISC NOT FINALIZED" is displayed. | <ul style="list-style-type: none"> - Use a finalised CD-RW or CD-R. |

DISMANTLING INSTRUCTIONS

Dismantling the 3CDC Module

- 1) Loosen the 4 screws, slide Cover top (pos 253) towards the rear and remove it upwards.
- 2) Loosen 3 screws slide the Panel right (pos 252) towards the rear and remove it outwards. Do likewise for the Panel left (pos 251).
- 3) Push the gear slowly towards the front as shown in figure 2 until the CDC tray starts to move out of the Front Cabinet (pos 101). The CDC tray is now disengage and can be pulled out completely.

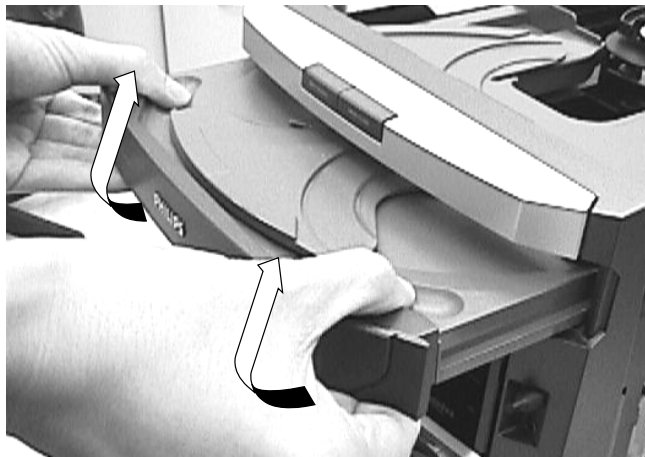

Figure 1

- 4) Remove the Cover Tray (pos 105) as shown in figure 2.
- 5) Loosen 4 screws A to remove the CDC Module (pos 1104) as shown in figure 2.

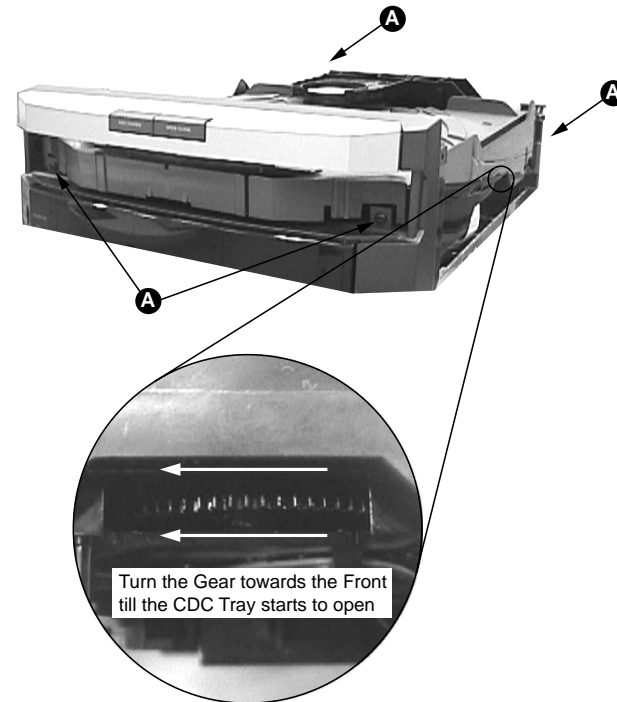

Figure 2

Dismantling of the Volume & Jog Rotary knobs

- 1) Cut a piece of packaging tape approximately 5cm width by 12cm length and tape its narrow side on to the top and bottom side of the Volume knob (pos 132) as shown in figure 3.
- 2) Place a small screw driver in between the tape & knob (see figure 3) to give more leverage in pulling out the knob as shown in figure 4.
- 3) Do likewise for the Jog Rotary knob (pos 131). You may have to rotate the knob to provide the most exposed area during application of the packaging tape.



Figure 3

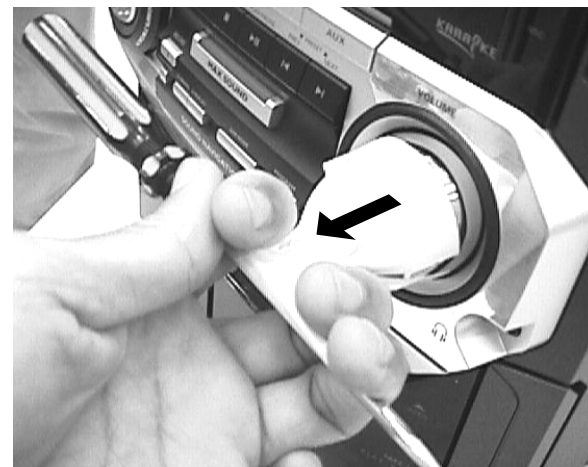

Figure 4

Dismantling of the Front Panel assembly

- 1) Loosen 2 screws below the Front Panel (pos 101) mounting it to the Bottom plate (pos 227).
- 2) Release the 2 catches on the sides of the Front Panel to separate it from the Bottom plate.
- 3) Remove the Volume and Jog Rotary knob if the Front board needs to be dismantled. For Karaoke versions, the Karaoke knob (pos 133) also need to be removed.
- 4) Loosen 8 screws B to remove the Front board as shown in Figure 5.
- 5) Loosen 6 screws C and eject both cassette doors to remove the Tape mechanism (pos 1103) as shown in figure 6.

Note: The Cassette door can be removed only after the removal of the Tape mechanism and buttons.

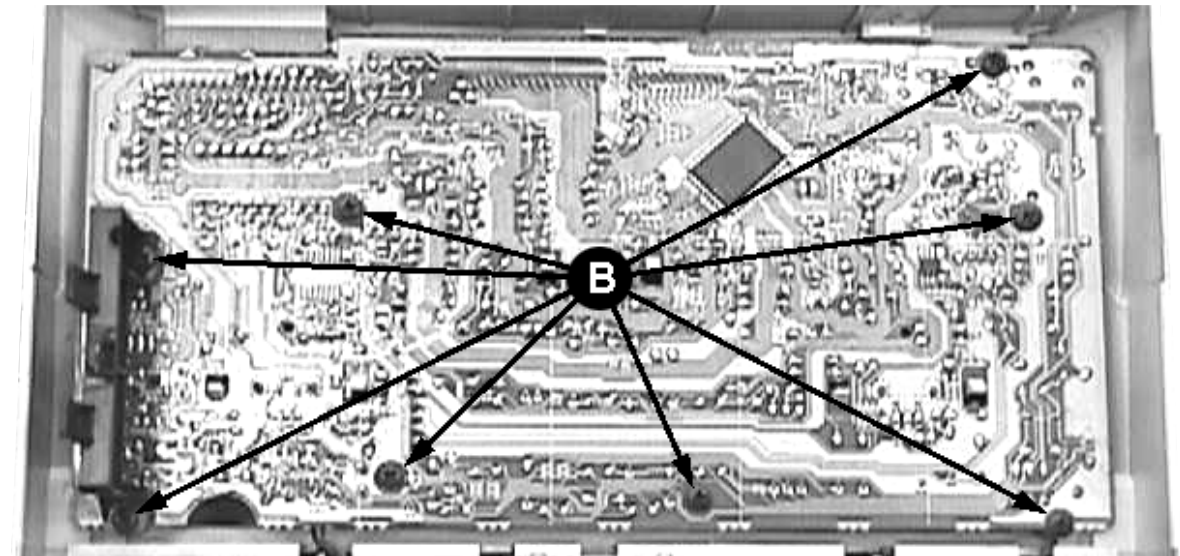

Figure 5

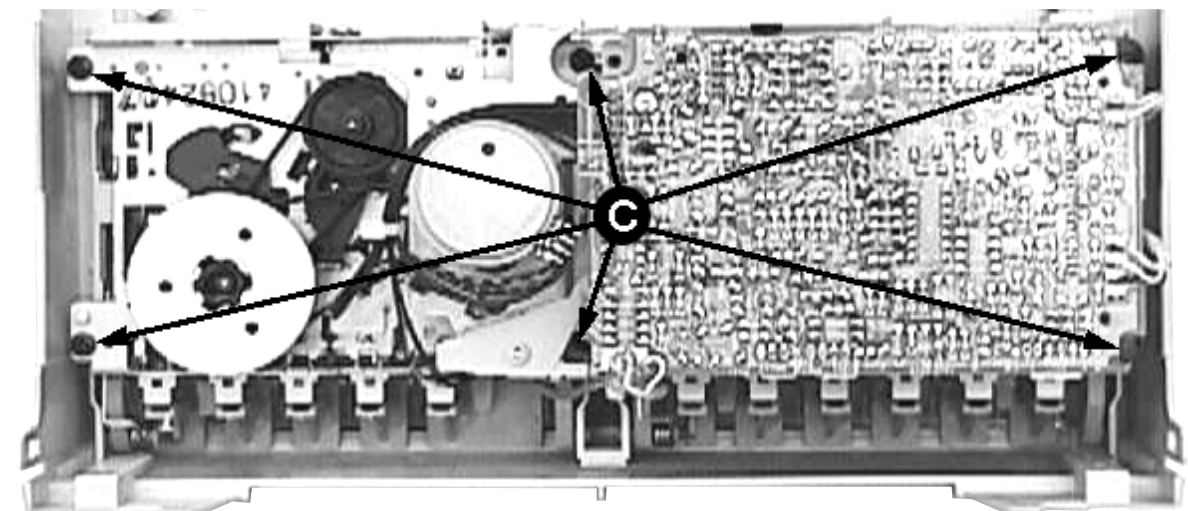

Figure 6

Dismantling of the Cassette door Lenses

- 1) Loosen the Lens Cassette Strip Left Top (pos 163) by pushing it towards the inside as indicated in Figure 7 and remove it by using a minus screw driver force it out as indicated in Figure 8.
- 2) Remove the Lens Cassette Left (pos 161) by pushing it towards the inside as indicated in Figure 7. Be careful not to damage or break the catch A.
- 3) Do likewise for the right Cassette Door Lens (pos 160 and 162).

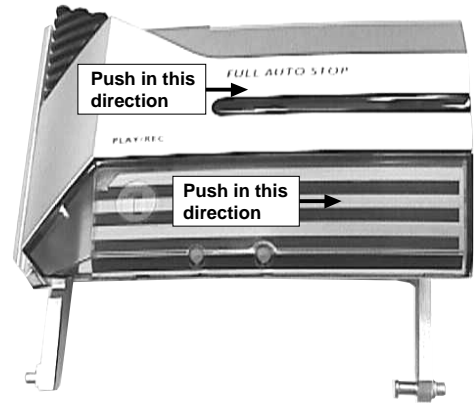

Figure 7

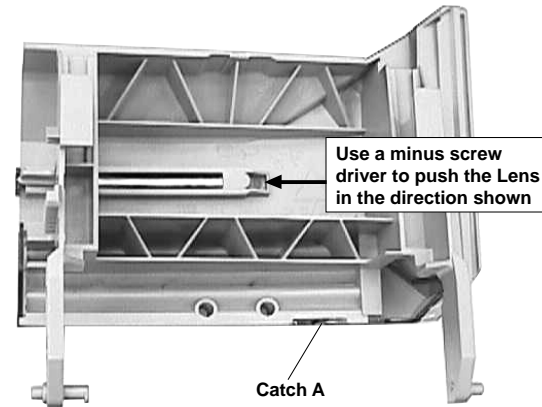

Figure 8

Dismantling of the Bottom & Rear Panel assembly

- 1) Loosen 5 screws D mounting the Combi board to the Rear Panel (pos 254) as shown in figure 9.
- 2) Loosen 3 screws E and release the 2 catches on the sides of the Rear Panel to separate it from the Bottom plate (pos 227).
- 3) Loosen 4 screws G to remove the Mains Transformer.
- 5) Loosen 2 screws F to remove the Combi Board.

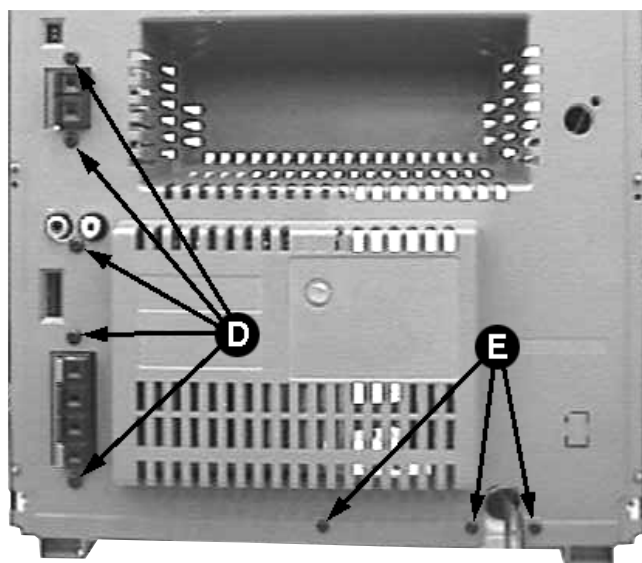

Figure 9

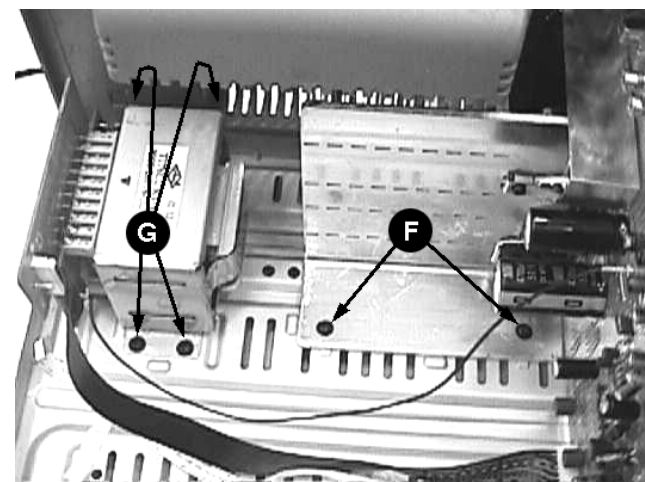
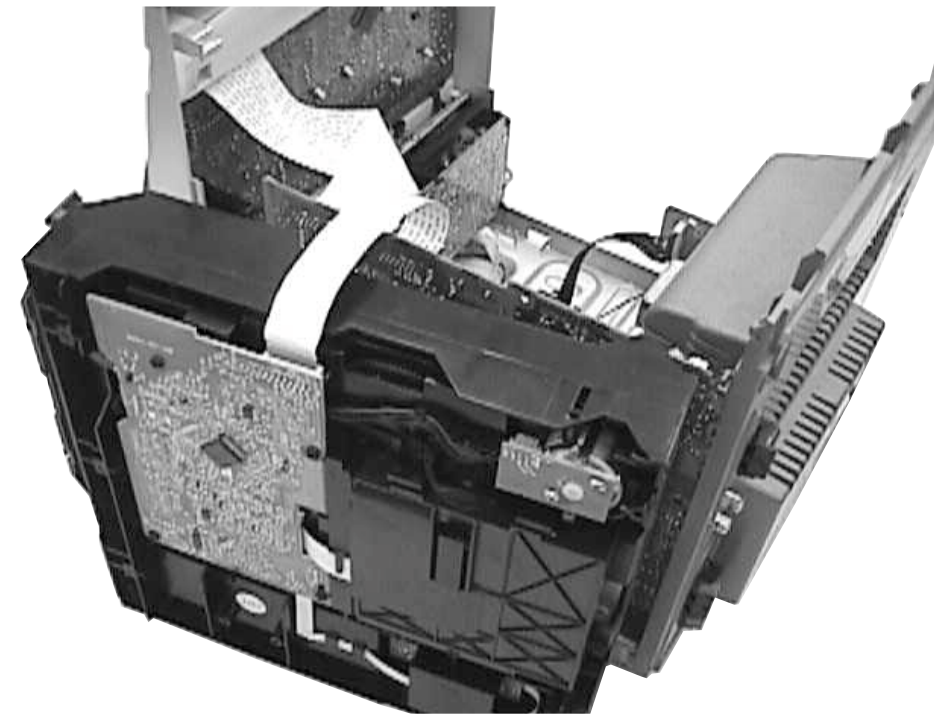

Figure 10

Service pos A



Note: After re-assembly, it is very important to ensure all wires are routed properly to ensure that they do not touch/obstruct all moving parts.

Service pos B

The 3CDC Module can be complete detached while repair the other portion of the set.

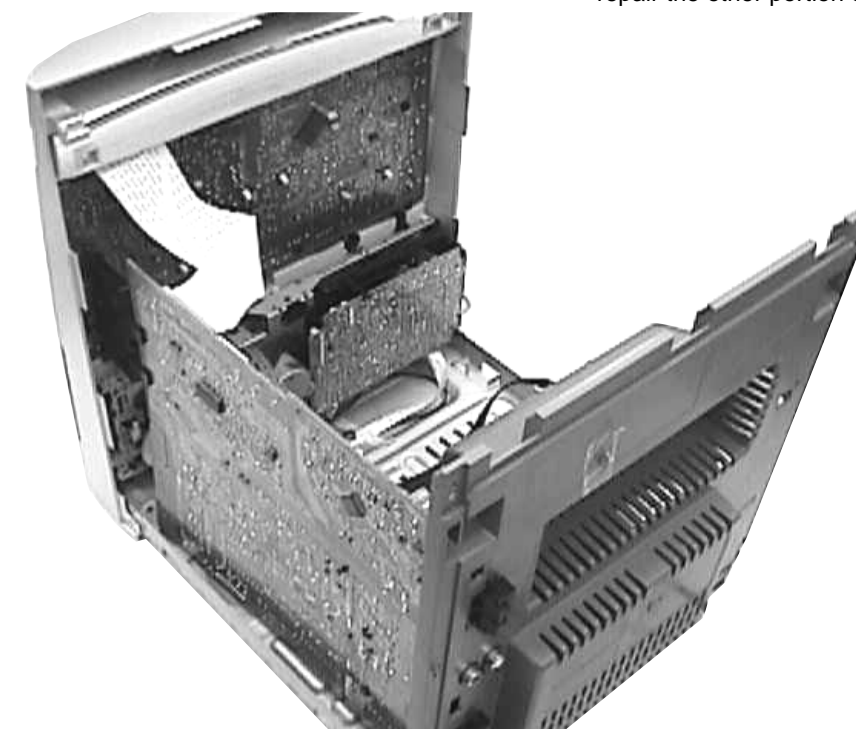

SERVICE TEST PROGRAM

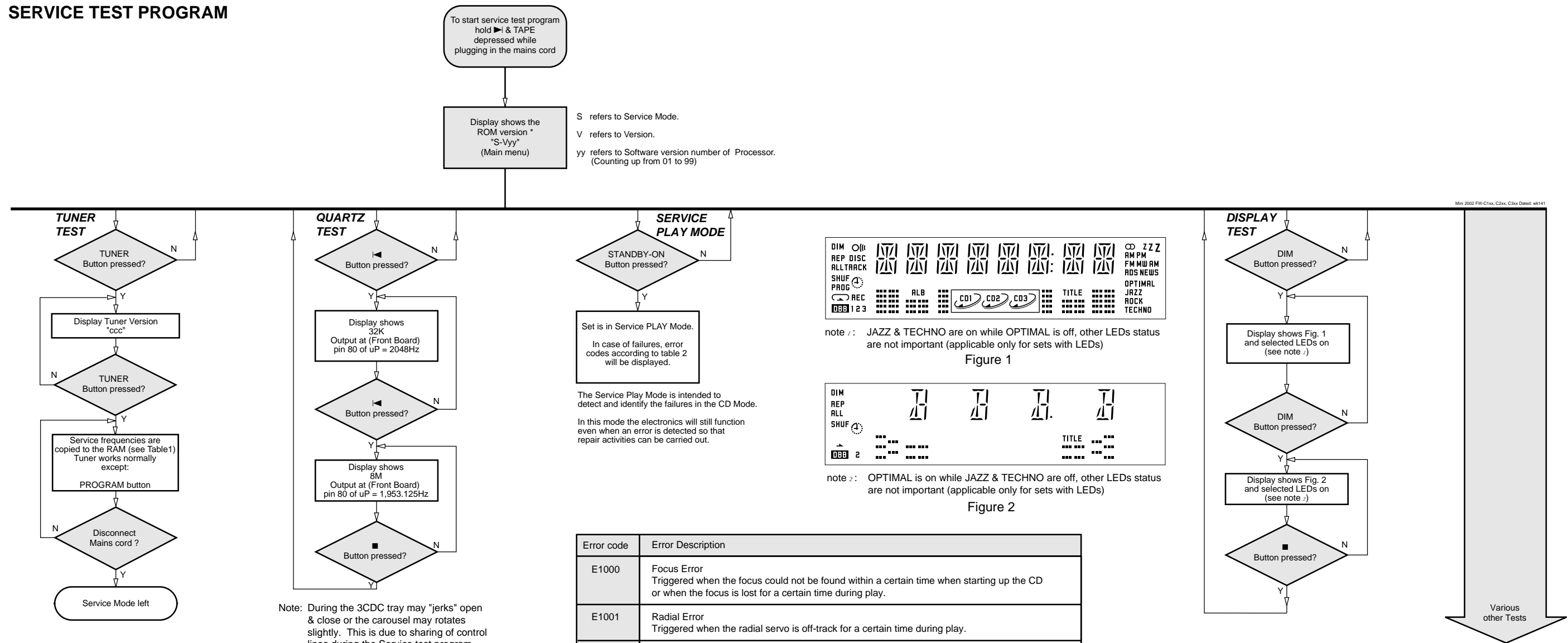

Note: During the 3CDC tray may "jerk" open & close or the carousel may rotate slightly. This is due to sharing of control lines during the Service test program.

PRESET	Europe "EUR"	East Eur. Extended-band "EAS"	East Eur. "EAS"	USA "USA"	Oversea "OSE"
1	87.5MHz	65.81MHz	87.5MHz	87.5MHz	87.5MHz
2	108MHz	108MHz	108MHz	108MHz	108MHz
3	531kHz	74MHz	531kHz	530kHz	530/531kHz*
4	1602kHz	87.5MHz	1602kHz	1700kHz	1700/1602kHz*
5	558kHz	531kHz	558kHz	560kHz	560/558kHz*
6	1494kHz	1602kHz	1494kHz	1500kHz	1500/1494kHz*
7	87.5MHz	558kHz	87.5MHz	98MHz	98/87.5MHz*
8	87.5MHz	1494kHz	87.5MHz	87.5MHz	87.5MHz
9	87.5MHz	98MHz	87.5MHz	87.5MHz	87.5MHz
10	87.5MHz	70.01MHz	87.5MHz	87.5MHz	87.5MHz
11	98MHz	65.81MHz	98MHz	87.5MHz	87.5/98MHz*

Table 1

Note: * Depending on the selected grid frequency (9 or 10kHz)
 By holding the TUNER and <TUNER> buttons depressed while switching on the Mains supply, one of the undermentioned features will be activated:
 - the tuning grid frequency is toggled between 9kHz and 10kHz for the Oversea (/21) version.
 - the extended FM1 (65.81MHz - 74MHz) is toggled on and off for East Eur. (/34) version.

Error code	Error Description
E1000	Focus Error Triggered when the focus could not be found within a certain time when starting up the CD or when the focus is lost for a certain time during play.
E1001	Radial Error Triggered when the radial servo is off-track for a certain time during play.
E1002	Sledge In Error The sledge did not reach its inner position (inner-switch is still close) before approximately 6 Sec. have passed by. Inner-switch or sledge motor problem.
E1003	Sledge Out Error The sledge did not come out of its inner position (inner-switch is still open) before approximately 250 mSec. have passed by. Inner-switch or sledge motor problem.
E1005	Jump-offtrack error Triggered in normal play when the jump destination could not be found within a certain time. When this error occurred, software will try to recover by initiating the jump command again. If it is recoverable, the disc will continue to play.
E1006	Subcode Error Triggered when a new subcode was missing for a certain time during play.
E1007	PLL Error The Phase Lock Loop could not lock within a certain time.
E1008	Turntable Motor Error Generated when the CD could not reached 75% of speed during startup within a certain time. Discmotor problem.
E1020	Focus Search Error The focus point has not been found within a certain time.
E1070	This happens when the carousel switch is defective and closed all the time, or when the carousel is blocked when it is located exactly at a disc position.
E1071	This happens when the carousel switch is defective and does not closed electrically, or when the carousel is blocked in between two disc positions. The time-out is approximately 5 Sec.
E1079	The drawer could not open or enter the inside position and is opening again. This happen when the drawer is blocked and cannot go fully inside or when the drawer switch is defective and does not close.

Table 2

TEST	Activated with	ACTION
EEPROM TEST	<TUNER> ■ to Exit	A test pattern will be sent to the EEPROM. "PASS" is displayed if the uProcessor read back the test pattern correctly, otherwise "FAIL" will be displayed.
EEPROM FORMAT	<TUNER>	Load default data. Display shows "NEW" for 1 second. Caution! All presets from the customer will be lost!!
ROTARY ENCODER TEST	Volume Knob or Jog Shuttle knob	Display shows value for 2 seconds. Values increases or decreases in steps of 1 until 0 (Min.) or 40 (Max.) is reached.
DEMO	DBB	DEMO will toggle on or off. The message: "DEMO ON" or "DEMO OFF" will scroll across the display to show the new status of the set.
LEAVE SERVICE TESTPROGRAM	Disconnect mains cord	

SET BLOCK DIAGRAM

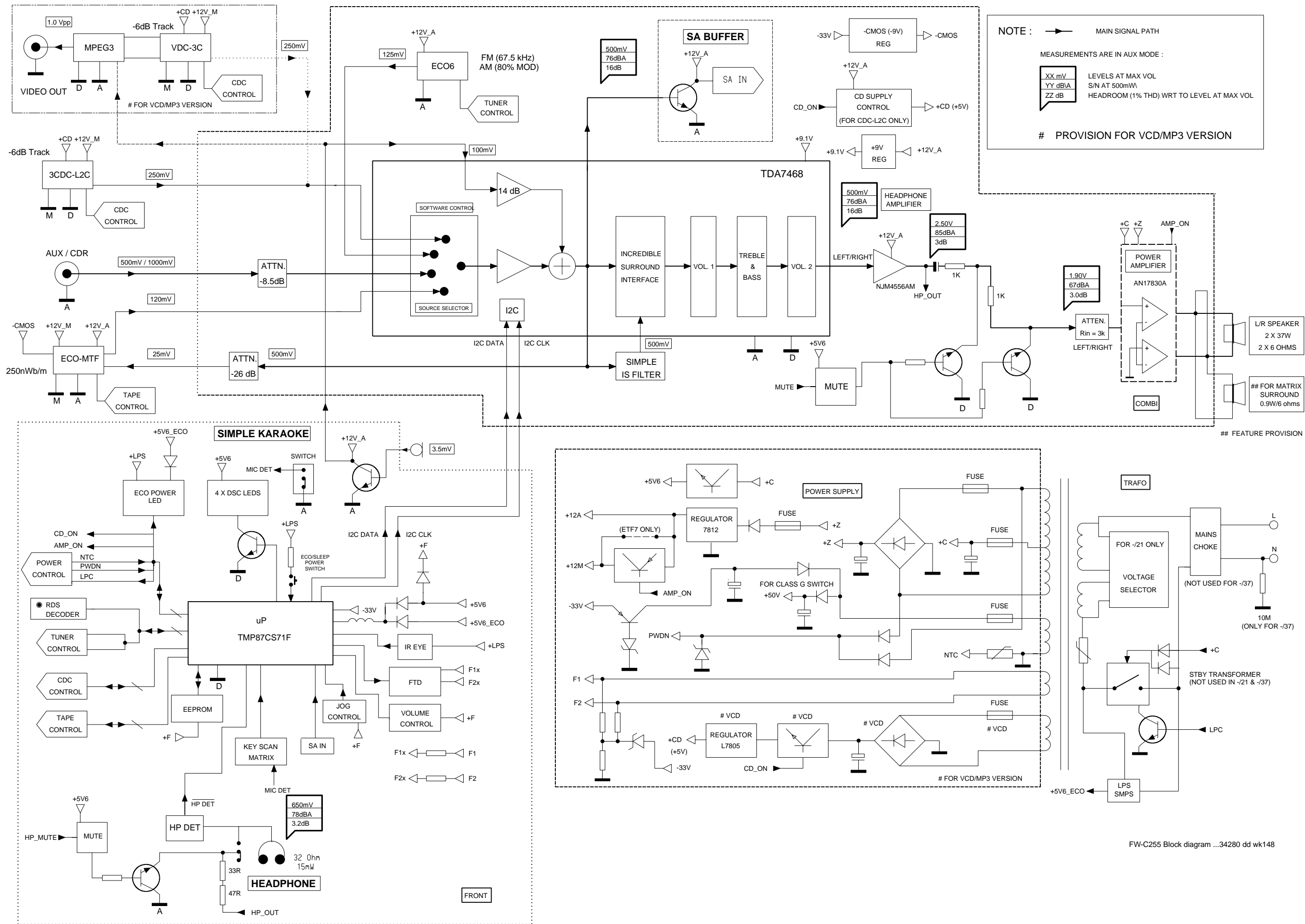

SET WIRING DIAGRAM

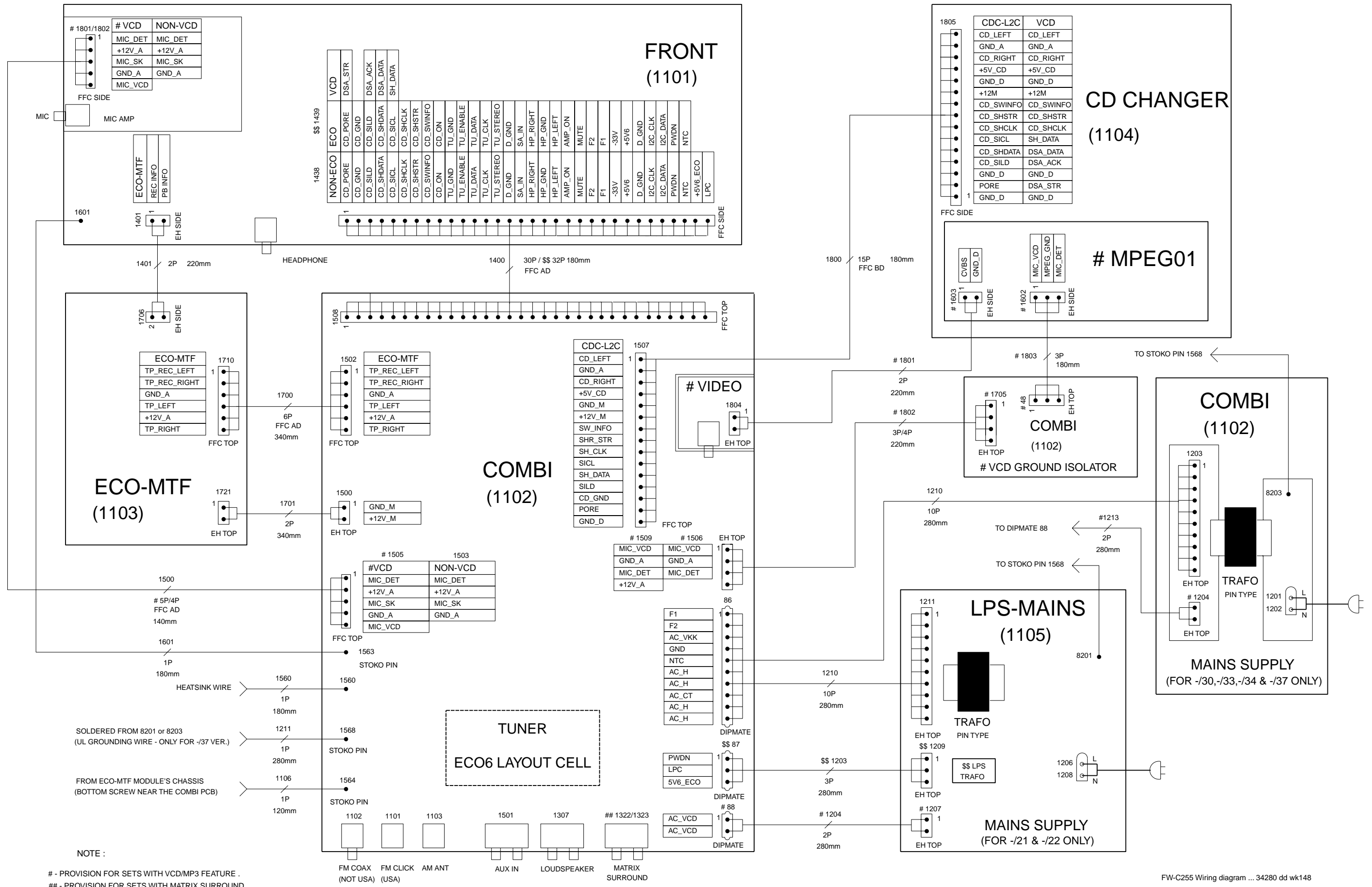

FRONT BOARD

TABLE OF CONTENTS

Variation Table and FTD Display pin connection 6-1
 Chip Layout 6-2
 Component Layout 6-3
 Circuit Diagram - Microprocessor part 6-4
 Circuit Diagram - Headphone / Miscellaneous part 6-5
 Electrical Parts List 6-7

Features / Item no.	Stroke Versions		Remarks
	/21/21M/33	/30/37	
Simple Karaoke	x	-	
Mic Detect	x	-	
RDS	-	-	
ECO Power LED	-	-	
1800	x	-	Mic Socket
1802	-	-	Karaoke
3492	820R	820R	NTC
3565	4R7	2R2	FTD Filament
3566	-	2R2	FTD Filament
3567	4R7	2R2	FTD Filament
3568	-	2R2	FTD Filament
4411	-	-	Karaoke
6429	-	-	Karaoke
9401	x	-	FTD Filament
9402	x	-	FTD Filament

FTD DISPLAY PIN CONNECTIONS

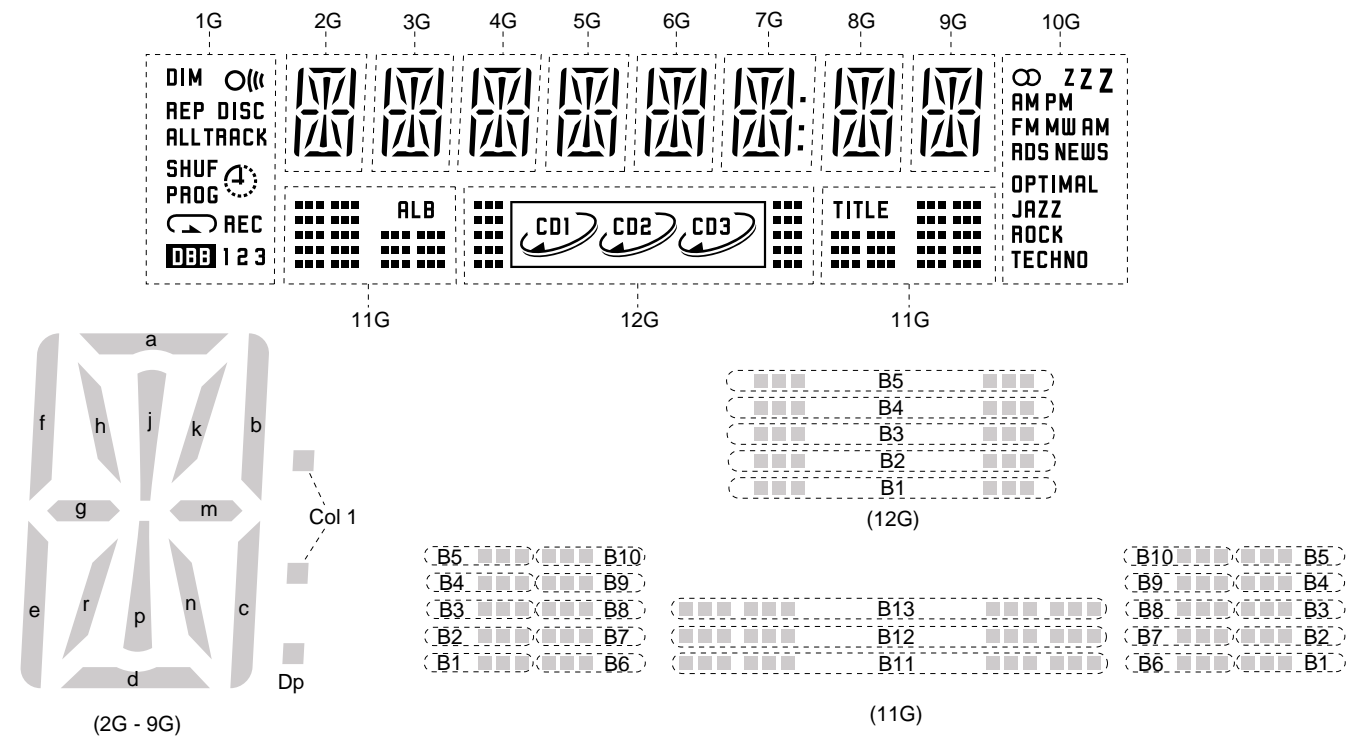

	12G	11G	10G	9G	8G	7G	6G	5G	4G	3G	2G	1G
P1	B1	B1	⊙	a	a	a	a	a	a	a	a	DIM
P2	B2	B2	Z (Left)	h	h	h	h	h	h	h	h	⊕
P3	B3	B3	Z (Middle)	j, p	j, p	j, p	j, p	j, p	j, p	j, p	j, p	REP
P4	B4	B4	Z (Right)	k	k	k	k	k	k	k	k	DISC
P5	B5	B5	AM (Up)	b	b	b	b	b	b	b	b	ALL
P6	CD1	B6	PM	f	f	f	f	f	f	f	f	TRACK
P7	CD2	B7	FM	m	m	m	m	m	m	m	m	SHUF
P8	CD3	B8	MW	g	g	g	g	g	g	g	g	PROG
P9	(1)	B9	AM (Low)	c	c	c	c	c	c	c	c	⌚
P10	(2)	B10	RDS	e	e	e	e	e	e	e	e	↪
P11	(3)	B11	NEWS	r	r	r	r	r	r	r	r	▶
P12	□	B12	OPTIMAL	n	n	n	n	n	n	n	n	REC
P13	-	B13	JAZZ	d	d	d	d	d	d	d	d	DBB
P14	-	ALB	ROCK	-	-	Col	-	-	-	-	-	1
P15	-	TITLE	TECHNO	-	-	Dp	-	-	-	-	-	2
P16	-	-	-	-	-	-	-	-	-	-	-	3

FTD DISPLAY PIN NO.	3	3	3	3	3	3	3	3	3	2	2	2	2	2	2	2	2	1	1	1	1	1	1	1	1	1	1	1	1	9	8	7	6	5	4	3	2	1
FUNCTION	F	-	-	-	1	2	3	4	5	6	7	8	9	10	11	12	-	-	P	P	P	P	P	P	P	P	P	P	P	P	P	P	P	P	-	-	-	F
	2				G	G	G	G	G	G	G	G	G	G	G	G			1	2	3	4	5	6	7	8	9	10	11	12	13	14	15	16				1

CIRCUIT DIAGRAM - MICROPROCESSOR PART

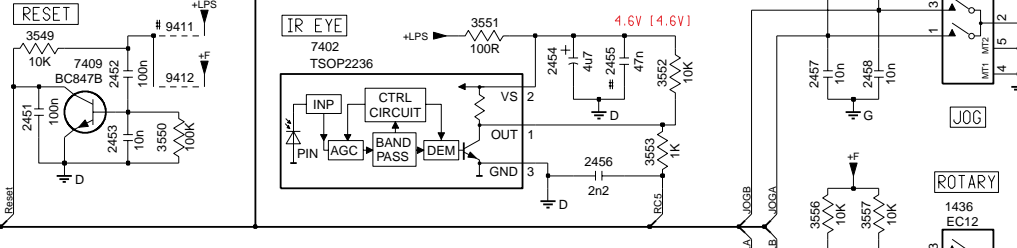
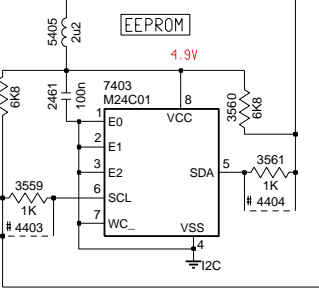
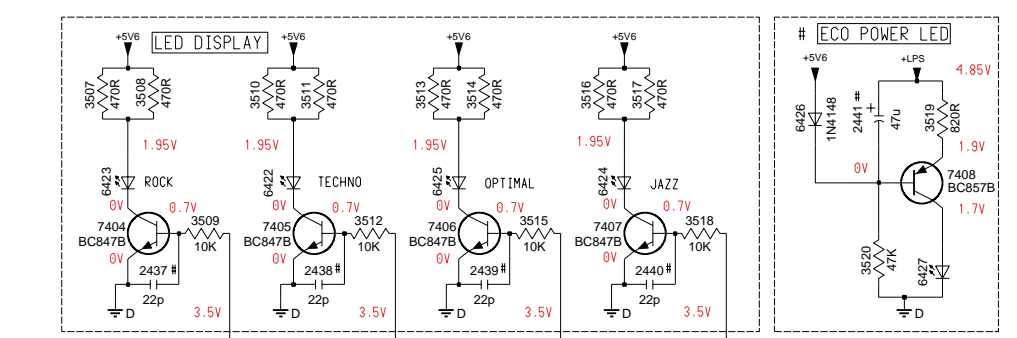
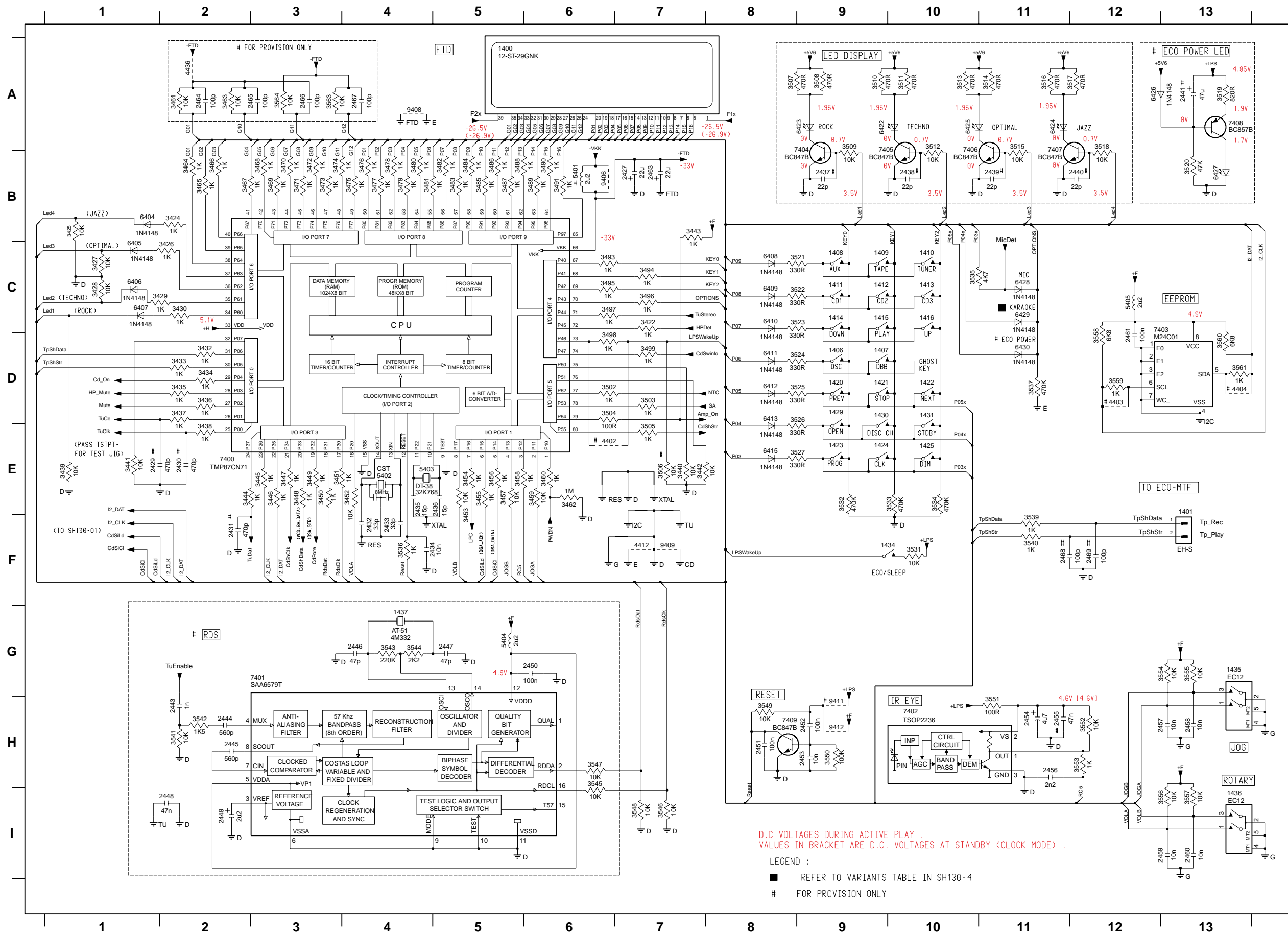

D.C VOLTAGES DURING ACTIVE PLAY .
 VALUES IN BRACKET ARE D.C. VOLTAGES AT STANDBY (CLOCK MODE) .

- LEGEND :
- REFER TO VARIANTS TABLE IN SH130-4
 - # FOR PROVISION ONLY

1400 A5	3474 B3	7405 B10
1401 E13	3475 B4	7406 B11
1406 D9	3476 B4	7407 B11
1407 D9	3477 B4	7408 A13
1408 C9	3478 B4	7409 H9
1409 C9	3479 B4	9408 B6
1410 C10	3480 B4	9408 A4
1411 C9	3481 B4	9409 F7
1412 C9	3482 B5	9411 H9
1413 C10	3483 B5	
1414 C9	3484 B5	
1415 C9	3485 B5	
1416 C10	3486 B5	
1420 D9	3487 B5	
1421 D9	3488 B5	
1422 D10	3489 B6	
1423 E9	3490 B6	
1424 E9	3491 B6	
1425 E10	3493 C6	
1429 D9	3494 C7	
1430 D9	3495 C6	
1431 D10	3496 C7	
1434 F10	3497 C6	
1435 G13	3498 D6	
1436 H13	3499 D7	
1437 G4	3502 D6	
2427 B7	3503 D7	
2429 E1	3504 D6	
2430 E2	3505 E7	
2431 F2	3506 E7	
2432 F4	3507 A8	
2433 F4	3508 A9	
2434 F4	3509 A9	
2435 E4	3510 A9	
2436 E5	3511 A10	
2437 B9	3512 A10	
2438 B10	3513 A10	
2439 B11	3514 A11	
2440 B12	3515 A11	
2441 A13	3516 A11	
2443 H2	3517 A12	
2444 H2	3518 A12	
2445 H2	3519 A13	
2446 G4	3520 B13	
2447 G5	3521 C9	
2448 I2	3522 C9	
2449 I2	3523 C9	
2450 G6	3524 D9	
2451 H8	3525 D9	
2452 H9	3526 D9	
2453 H9	3527 E9	
2454 H11	3528 F10	
2455 H11	3529 E9	
2456 H11	3530 E10	
2457 H13	3531 E10	
2458 H13	3532 C10	
2459 H13	3533 F4	
2460 H13	3534 D11	
2461 D12	3535 F11	
2463 B7	3540 F11	
2464 A2	3541 H2	
2465 A3	3542 H2	
2466 A3	3543 G4	
2467 A4	3544 G4	
2468 F11	3545 H6	
2469 F12	3546 I7	
3422 C7	3547 H6	
3424 B2	3548 I7	
3425 B1	3549 H8	
3426 C1	3550 H9	
3427 C1	3551 H11	
3428 C1	3552 H12	
3429 C2	3553 H12	
3430 C2	3554 G13	
3432 D2	3555 G13	
3433 D2	3556 H3	
3434 D2	3557 H3	
3435 D2	3558 D12	
3436 D2	3559 D12	
3437 D2	3560 D13	
3438 E2	3561 D13	
3439 E1	3563 A3	
3440 E1	3564 A3	
3441 E1	4402 E6	
3442 E7	4403 D12	
3443 B7	4404 D13	
3444 E2	4412 F7	
3445 E3	4436 A2	
3446 E3	5401 B6	
3447 E3	5402 E4	
3448 E3	5403 E4	
3449 E3	5404 G5	
3450 E3	5405 C12	
3451 E3	6404 B1	
3452 E4	6405 C1	
3453 F5	6406 C1	
3454 E5	6407 C1	
3455 E5	6408 C8	
3456 E5	6409 C8	
3457 E5	6410 C8	
3458 E5	6411 D8	
3459 E6	6412 D8	
3460 E6	6413 D8	
3461 A2	6415 E8	
3462 E6	6422 A9	
3463 A2	6423 A9	
3464 B2	6424 A11	
3465 B2	6425 A10	
3466 B2	6426 A12	
3467 B2	6427 B13	
3468 B3	6428 C11	
3469 B3	6429 C11	
3470 B3	6430 D11	
3471 B3	7402 H10	
3472 B3	7403 C12	
3473 B3	7404 B9	

CIRCUIT DIAGRAM - HEADPHONE / MISCELLANEOUS PART

1438 A1	2400 E3	2404 B7	2408 B9	2412 B4	2416 A4	2420 A5	2424 F3	2600 D8	2604 E7	3402 B9	3408 F5	3413 A3	3417 C3	3421 C8	3565 A8	3569 B6	3603 D8	4401 E5	4408 C4	4413 E4	5400 B7	6400 A7	6600 F7	9401 A9	9487 F5
1439 A1	2401 A7	2405 B7	2409 B9	2413 C3	2417 A4	2421 F2	2425 C7	2601 E8	2605 E7	3405 F5	3410 A2	3414 C2	3418 C7	3492 F4	3566 A9	3600 E6	3604 F7	4405 F5	4409 E4	4414 E5	5600 D7	6401 A7	7600 E7	9402 A9	9506 F3
1600 E9	2402 A7	2406 A9	2410 F5	2414 A4	2418 A4	2422 F2	2426 C8	2602 F8	2606 F8	3406 E5	3411 A2	3415 C2	3419 C7	3528 E5	3567 B8	3601 E6	3605 F7	4406 F4	4410 B5	4415 A5	5601 E7	6402 B7	7601 E7	9404 D5	9514 F3
1601 F8	2403 A7	2407 A9	2411 F5	2415 A4	2419 A5	2423 F3	2470 B6	2603 F7	3400 A9	3407 E4	3412 A3	3416 C3	3420 C7	3562 F4	3568 B9	3602 D8	4400 E4	4407 B5	4411 D5	4460 F2	5602 E8	6420 C7	7602 F6	9410 C5	

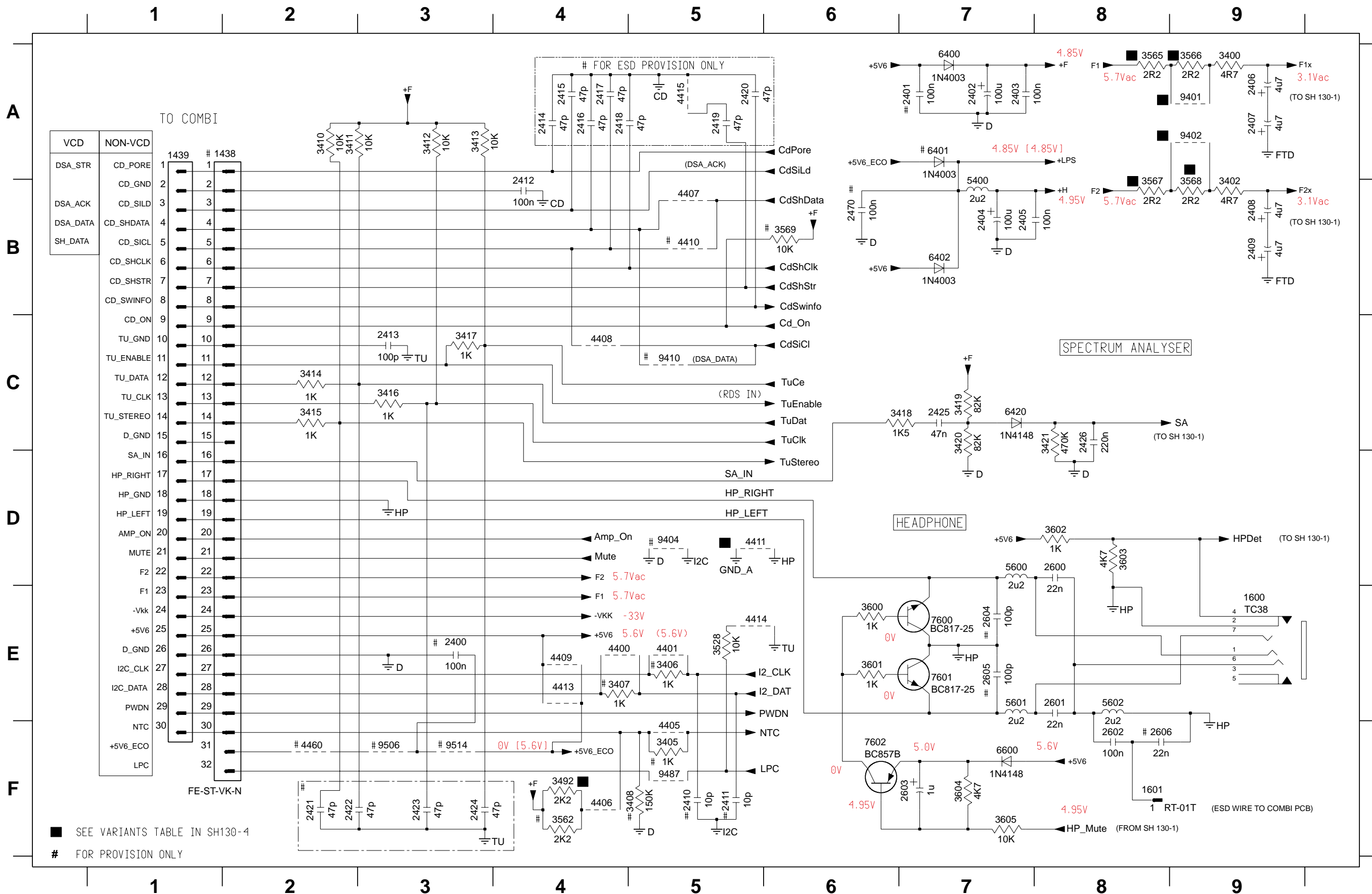

ELECTRICAL PARTS LIST - FRONT BOARD

MISCELLANEOUS

1400	3139 110 52850	FTD Display 12-ST-29GNK
1406	2422 128 02917	Tact Switch
1407	2422 128 02917	Tact Switch
1408	2422 128 02917	Tact Switch
1409	2422 128 02917	Tact Switch
1410	2422 128 02917	Tact Switch
1411	2422 128 02917	Tact Switch
1412	2422 128 02917	Tact Switch
1413	2422 128 02917	Tact Switch
1414	2422 128 02917	Tact Switch
1415	2422 128 02917	Tact Switch
1416	2422 128 02917	Tact Switch
1420	2422 128 02917	Tact Switch
1421	2422 128 02917	Tact Switch
1422	2422 128 02917	Tact Switch
1423	2422 128 02917	Tact Switch
1424	2422 128 02917	Tact Switch
1425	2422 128 02917	Tact Switch
1429	2422 128 02917	Tact Switch
1430	2422 128 02917	Tact Switch
1431	2422 128 02917	Tact Switch
1434	2422 128 02917	Tact Switch
1435	2422 129 16707	Rotary Encoder 24P
1436	2422 129 16708	Rotary Encoder 24P
1439	2422 025 17414	Flex Socket 30pin Hort.
1600	2422 026 05059	Headphone Socket
1800	2422 026 05059	Mic Socket /21/21M
1802	4822 265 11183	Flex Socket 4pin Hort. /21/21M

CAPACITORS

2402	4822 124 23432	100µF 20% 10V
2403	4822 126 14305	100nF 10% 16V
2404	4822 124 23432	100µF 20% 10V
2405	4822 126 14305	100nF 10% 16V
2406	4822 124 12032	4,7µF 20% 50V
2407	4822 124 12032	4,7µF 20% 50V
2408	4822 124 12032	4,7µF 20% 50V
2409	4822 124 12032	4,7µF 20% 50V
2412	4822 126 14305	100nF 10% 16V
2413	4822 122 31765	100pF 2% 63V
2425	3198 017 34730	47nF 16V
2426	4822 126 13879	220nF +80/-20% 16V
2427	3198 028 52290	22µF 20% 50V
2428	3198 017 41050	1µF 10V /21/21M
2432	2222 867 15339	33pF 50V
2433	2222 867 15339	33pF 50V
2434	5322 126 11583	10nF 10% 50V
2435	4822 122 33752	15pF 5% 50V
2436	4822 122 33752	15pF 5% 50V
2451	4822 126 14305	100nF 10% 16V
2452	4822 126 14305	100nF 10% 16V
2453	5322 126 11583	10nF 10% 50V

2454	4822 124 12032	4,7µF 20% 50V
2456	4822 126 14238	2,2nF 50V
2457	5322 126 11583	10nF 10% 50V
2458	5322 126 11583	10nF 10% 50V
2459	5322 126 11583	10nF 10% 50V
2460	5322 126 11583	10nF 10% 50V
2461	4822 126 14305	100nF 10% 16V
2463	3198 028 52290	22µF 20% 50V
2600	4822 126 14494	22nF 10% 25V
2601	4822 126 14494	22nF 10% 25V
2602	4822 126 14305	100nF 10% 16V
2603	4822 124 22651	1µF 20% 50V
2801	4822 126 13193	4,7nF 10% 63V /21/21M
2802	4822 126 14305	100nF 10% 16V /21/21M
2803	5322 126 11578	1nF 10% 50V /21/21M
2804	3198 017 44740	470nF 10V /21/21M
2805	3198 017 44740	470nF 10V /21/21M
2806	4822 126 13909	680pF 10% 50V /21/21M
2807	4822 124 81286	47µF 20% 16V /21/21M
2808	3198 017 41050	1µF 10V /21/21M

RESISTORS

3400	4822 050 24708	4R7 1% 0,6W
3402	4822 050 24708	4R7 1% 0,6W
3410	4822 051 30103	10k 5% 0,062W
3411	4822 051 30103	10k 5% 0,062W
3412	4822 051 30103	10k 5% 0,062W
3413	4822 051 30103	10k 5% 0,062W
3414	4822 051 30102	1k 5% 0,062W
3415	4822 050 11002	1k 1% 0,4W
3416	4822 051 30102	1k 5% 0,062W
3417	4822 051 30102	1k 5% 0,062W
3418	4822 116 52243	1k5 5% 0,5W
3419	4822 117 12864	82k 5% 0,6W
3420	4822 117 12864	82k 5% 0,6W
3421	4822 051 30474	470k 5% 0,062W
3422	4822 051 30102	1k 5% 0,062W
3423	4822 051 30103	10k 5% 0,062W /21/21M
3424	4822 051 30102	1k 5% 0,062W
3425	4822 051 30103	10k 5% 0,062W
3426	4822 051 30102	1k 5% 0,062W
3427	4822 051 30103	10k 5% 0,062W
3428	4822 051 30103	10k 5% 0,062W
3429	4822 051 30102	1k 5% 0,062W
3430	4822 051 30102	1k 5% 0,062W
3432	4822 051 30102	1k 5% 0,062W
3433	4822 051 30102	1k 5% 0,062W
3434	4822 051 30102	1k 5% 0,062W
3435	4822 051 30102	1k 5% 0,062W
3436	4822 051 30102	1k 5% 0,062W
3437	4822 051 30102	1k 5% 0,062W
3438	4822 051 30102	1k 5% 0,062W

ELECTRICAL PARTS LIST - FRONT BOARD

3439	4822 051 30103	10k 5% 0,062W
3440	4822 051 30103	10k 5% 0,062W
3441	4822 050 21003	10k 1% 0,6W
3442	4822 051 30103	10k 5% 0,062W
3443	4822 051 30102	1k 5% 0,062W
3444	4822 051 30102	1k 5% 0,062W
3445	4822 051 30102	1k 5% 0,062W
3446	4822 051 30102	1k 5% 0,062W
3447	4822 051 30102	1k 5% 0,062W
3448	4822 051 30102	1k 5% 0,062W
3449	4822 050 11002	1k 1% 0,4W
3450	4822 051 30102	1k 5% 0,062W
3451	4822 051 30102	1k 5% 0,062W
3452	4822 050 21003	10k 1% 0,6W
3453	4822 051 30103	10k 5% 0,062W
3454	4822 051 30102	1k 5% 0,062W
3455	4822 051 30102	1k 5% 0,062W
3456	4822 051 30102	1k 5% 0,062W
3457	4822 050 21003	10k 1% 0,6W
3458	4822 051 30102	1k 5% 0,062W
3459	4822 050 21003	10k 1% 0,6W
3460	4822 051 30102	1k 5% 0,062W
3462	4822 051 30105	1M 5% 0,062W
3464	4822 051 30102	1k 5% 0,062W
3465	4822 051 30102	1k 5% 0,062W
3466	4822 051 30102	1k 5% 0,062W
3467	4822 051 30102	1k 5% 0,062W
3468	4822 051 30102	1k 5% 0,062W
3469	4822 051 30102	1k 5% 0,062W
3470	4822 051 30102	1k 5% 0,062W
3471	4822 051 30102	1k 5% 0,062W
3472	4822 051 30102	1k 5% 0,062W
3473	4822 051 30102	1k 5% 0,062W
3474	4822 051 30102	1k 5% 0,062W
3475	4822 051 30102	1k 5% 0,062W
3476	4822 051 30102	1k 5% 0,062W
3477	4822 051 30102	1k 5% 0,062W
3478	4822 051 30102	1k 5% 0,062W
3479	4822 051 30102	1k 5% 0,062W
3480	4822 051 30102	1k 5% 0,062W
3481	4822 051 30102	1k 5% 0,062W
3482	4822 051 30102	1k 5% 0,062W
3483	4822 051 30102	1k 5% 0,062W
3484	4822 051 30102	1k 5% 0,062W
3485	4822 051 30102	1k 5% 0,062W
3486	4822 051 30102	1k 5% 0,062W
3487	4822 051 30102	1k 5% 0,062W
3488	4822 051 30102	1k 5% 0,062W
3489	4822 051 30102	1k 5% 0,062W
3490	4822 051 30102	1k 5% 0,062W
3491	4822 051 30102	1k 5% 0,062W
3492	4822 117 12968	820R 5% 0,62W

3493	4822 051 30102	1k 5% 0,062W
3494	4822 051 30102	1k 5% 0,062W
3495	4822 051 30102	1k 5% 0,062W
3496	4822 051 30102	1k 5% 0,062W
3497	4822 051 30102	1k 5% 0,062W
3498	4822 051 30102	1k 5% 0,062W
3499	4822 051 30102	1k 5% 0,062W
3502	4822 051 30102	1k 5% 0,062W
3503	4822 051 30102	1k 5% 0,062W
3504	4822 051 30101	100R 5% 0,062W
3505	4822 051 30102	1k 5% 0,062W
3507	4822 051 30471	470R 5% 0,062W
3508	4822 051 30471	470R 5% 0,062W
3509	4822 051 30103	10k 5% 0,062W
3510	4822 051 30471	470R 5% 0,062W
3511	4822 051 30471	470R 5% 0,062W
3512	4822 051 30103	10k 5% 0,062W
3513	4822 051 30471	470R 5% 0,062W
3514	4822 051 30471	470R 5% 0,062W
3515	4822 051 30103	10k 5% 0,062W
3516	4822 051 30471	470R 5% 0,062W
3517	4822 051 30471	470R 5% 0,062W
3518	4822 051 30103	10k 5% 0,062W
3521	4822 051 30331	330R 5% 0,062W
3522	4822 116 52219	330R 5% 0,5W
3523	4822 116 52219	330R 5% 0,5W
3524	4822 116 52219	330R 5% 0,5W
3525	4822 116 52219	330R 5% 0,5W
3526	4822 116 52219	330R 5% 0,5W
3527	4822 116 52219	330R 5% 0,5W
3528	4822 051 30103	10k 5% 0,062W
3531	4822 051 30103	10k 5% 0,062W
3532	4822 051 30474	470k 5% 0,062W
3533	4822 051 30474	470k 5% 0,062W
3534	4822 051 30474	470k 5% 0,062W
3535	4822 051 30472	4k7 5% 0,062W
3536	4822 050 11002	1k 1% 0,4W
3537	4822 051 30474	470k 5% 0,062W
3539	4822 050 11002	1k 1% 0,4W
3540	4822 050 11002	1k 1% 0,4W
3546	4822 051 30103	10k 5% 0,062W
3548	4822 051 30103	10k 5% 0,062W
3549	4822 051 30103	10k 5% 0,062W
3550	4822 117 13632	100k 1% 0,062W
3551	4822 051 30101	100R 5% 0,062W
3552	4822 051 30103	10k 5% 0,062W
3553	4822 051 30102	1k 5% 0,062W
3554	4822 051 30103	10k 5% 0,062W
3555	4822 051 30103	10k 5% 0,062W
3556	4822 051 30103	10k 5% 0,062W
3557	4822 051 30103	10k 5% 0,062W
3558	4822 051 30682	6k8 5% 0,062W

ELECTRICAL PARTS LIST - FRONT BOARD**RESISTORS**

3559	4822 051 30102	1k 5% 0,062W	4432	4822 051 30008	0R Jumper 0603
3560	4822 051 30682	6k8 5% 0,062W	4433	4822 051 30008	0R Jumper 0603
3561	4822 051 30102	1k 5% 0,062W	4434	4822 051 30008	0R Jumper 0603
3565	4822 050 24708	4R7 5% 0,5W /21/21M	4435	4822 051 30008	0R Jumper 0603
3565	4822 116 81154	2R2 5% 0,5W /30/37	4436	4822 051 30008	0R Jumper 0603 /30/37
3566	4822 116 81154	2R2 5% 0,5W /30/37	4437	4822 051 30008	0R Jumper 0603
3567	4822 050 24708	4R7 5% 0,5W /21/21M	4438	4822 051 30008	0R Jumper 0603
3567	4822 116 81154	2R2 5% 0,5W /30/37	4439	4822 051 30008	0R Jumper 0603
3568	4822 116 81154	2R2 5% 0,5W /30/37	4440	4822 051 30008	0R Jumper 0603
3600	4822 051 30102	1k 5% 0,062W	4441	4822 051 30008	0R Jumper 0603
3601	4822 051 30102	1k 5% 0,062W	4442	4822 051 30008	0R Jumper 0603
3602	4822 050 11002	1k 1% 0,4W	4443	4822 051 30008	0R Jumper 0603
3603	4822 051 30472	4k7 5% 0,062W	4444	4822 051 30008	0R Jumper 0603
3604	4822 051 30472	4k7 5% 0,062W	4445	4822 051 30008	0R Jumper 0603
3605	4822 051 30103	10k 5% 0,062W	4446	4822 051 30008	0R Jumper 0603
3800	4822 116 52283	4k7 5% 0,5W /21/21M	4447	4822 051 30008	0R Jumper 0603
3801	4822 051 30682	6k8 5% 0,062W /21/21M	4448	4822 051 30008	0R Jumper 0603
3802	4822 051 30103	10k 5% 0,062W /21/21M	4449	4822 051 30008	0R Jumper 0603
3803	4822 051 30103	10k 5% 0,062W /21/21M	4450	4822 051 30008	0R Jumper 0603
3804	4822 051 30272	2k7 5% 0,062W /21/21M	4451	4822 051 30008	0R Jumper 0603
3805	4822 051 30105	1M 5% 0,062W /21/21M	4452	4822 051 30008	0R Jumper 0603
3806	4822 051 30339	33R 5% 0,062W /21/21M	4453	4822 051 30008	0R Jumper 0603
3807	2120 366 90292	Potm Rotary 20K /21/21M	4454	4822 051 30008	0R Jumper 0603
3808	4822 051 30471	470R 5% 0,062W /21/21M	4455	4822 051 30008	0R Jumper 0603
3809	4822 051 30561	560R 5% 0,062W /21/21M	4456	4822 051 30008	0R Jumper 0603
3810	4822 051 30105	1M 5% 0,062W /21/21M	4457	4822 051 30008	0R Jumper 0603
3811	4822 051 30331	330R 5% 0,062W /21/21M	4458	4822 051 30008	0R Jumper 0603
3812	4822 051 30103	10k 5% 0,062W /21/21M	4459	4822 051 30008	0R Jumper 0603
3813	4822 051 30471	470R 5% 0,062W /21/21M	4461	4822 051 30008	0R Jumper 0603
4400	4822 051 30008	0R Jumper 0603	4462	4822 051 30008	0R Jumper 0603
4401	4822 051 30008	0R Jumper 0603	4463	4822 051 30008	0R Jumper 0603
4405	4822 051 30008	0R Jumper 0603	4464	4822 051 30008	0R Jumper 0603
4406	4822 051 30008	0R Jumper 0603	4465	4822 051 30008	0R Jumper 0603
4407	4822 051 30008	0R Jumper 0603	4466	4822 051 30008	0R Jumper 0603
4408	4822 051 30008	0R Jumper 0603	4467	4822 051 30008	0R Jumper 0603
4409	4822 051 30008	0R Jumper 0603	4468	4822 051 30008	0R Jumper 0603
4411	4822 051 30008	0R Jumper 0603 /21/21M	4469	4822 051 30008	0R Jumper 0603
4412	4822 051 30008	0R Jumper 0603	4470	4822 051 30008	0R Jumper 0603
4413	4822 051 30008	0R Jumper 0603	4471	4822 051 30008	0R Jumper 0603
4414	4822 051 30008	0R Jumper 0603	4472	4822 051 30008	0R Jumper 0603
4420	4822 051 30008	0R Jumper 0603	4473	4822 051 30008	0R Jumper 0603
4421	4822 051 30008	0R Jumper 0603	4474	4822 051 30008	0R Jumper 0603
4422	4822 051 30008	0R Jumper 0603	4475	4822 051 30008	0R Jumper 0603
4423	4822 051 30008	0R Jumper 0603	4476	4822 051 30008	0R Jumper 0603
4424	4822 051 30008	0R Jumper 0603	4477	4822 051 30008	0R Jumper 0603
4425	4822 051 30008	0R Jumper 0603	4478	4822 051 30008	0R Jumper 0603
4426	4822 051 30008	0R Jumper 0603	4479	4822 051 30008	0R Jumper 0603
4427	4822 051 30008	0R Jumper 0603	4480	4822 051 30008	0R Jumper 0603
4428	4822 051 30008	0R Jumper 0603	4481	4822 051 30008	0R Jumper 0603
4429	4822 051 30008	0R Jumper 0603	4601	4822 051 30008	0R Jumper 0603
4430	4822 051 30008	0R Jumper 0603	4801	4822 051 30008	0R Jumper 0603 /21/21M
4431	4822 051 30008	0R Jumper 0603	4802	4822 051 30008	0R Jumper 0603 /21/21M

ELECTRICAL PARTS LIST - FRONT BOARD

4803	4822 051 30008	0R Jumper 0603 /21/21M	7800	4822 130 60511	BC847B /21/21M
4804	4822 051 30008	0R Jumper 0603 /21/21M	7801	4822 130 60511	BC847B /21/21M
4805	4822 051 30008	0R Jumper 0603 /21/21M			
4808	4822 051 30008	0R Jumper 0603			Note: Only the parts mentioned in this list are normal service spare parts.
4810	4822 051 30008	0R Jumper 0603			

COILS & FILTERS

5400	4822 157 62552	Coil 2,2μH 5%
5402	4822 242 72066	Ceram Resonator 8MHz
5403	2422 543 01069	X'tal Resonator 32,768kHz
5405	4822 157 62552	Coil 2,2μH 5%
5600	4822 157 62552	Coil 2,2μH 5%
5601	4822 157 62552	Coil 2,2μH 5%
5602	4822 157 62552	Coil 2,2μH 5%
5800	4822 157 11235	Coil 22μH 5% /21/21M

DIODES

6400	4822 130 31878	1N4003G
6402	4822 130 31878	1N4003G
6404	4822 130 30621	1N4148
6405	4822 130 30621	1N4148
6406	4822 130 30621	1N4148
6407	4822 130 30621	1N4148
6408	4822 130 30621	1N4148
6409	4822 130 30621	1N4148
6410	4822 130 30621	1N4148
6411	4822 130 30621	1N4148
6412	4822 130 30621	1N4148
6413	4822 130 30621	1N4148
6415	4822 130 30621	1N4148
6420	4822 130 30621	1N4148
6422	9322 178 15676	LTL-8166FTNN
6423	9322 178 15676	LTL-8166FTNN
6424	9322 178 15676	LTL-8166FTNN
6425	9322 178 15676	LTL-8166FTNN
6428	4822 130 30621	1N4148
6429	4822 130 30621	1N4148 /21/21M
6600	4822 130 30621	1N4148

TRANSISTORS & INTEGRATED CIRCUITS

7400	3139 110 52941	TMP87CS71F "C255S52941"
7402	9322 155 22667	IR Receiver TSOP2236ZC1
7403	9965 000 04931	M24C01-WMN6
7404	4822 130 60511	BC847B
7405	4822 130 60511	BC847B
7406	4822 130 60511	BC847B
7407	4822 130 60511	BC847B
7409	4822 130 60511	BC847B
7411	4822 130 60511	BC847B /21/21M
7600	4822 130 42804	BC817-25
7601	4822 130 42804	BC817-25
7602	4822 130 60373	BC857B

MAINS BOARD

TABLE OF CONTENTS

Component Layout	8-1
Circuit Diagram	8-2
Electrical parts list	8-1

COMPONENT LAYOUT

1201	A5 1211	C1 2207	A2 2215	A1 3209	B1 3221	B2 5006	D4 5014	C3 5206	A5 6208	A2 6216	A3 7205	A3 9206	C5 9216	C3 9224	D4
1204	B4 1212	D1 2208	B4 3202	A2 3212	C1 3222	B1 5007	D4 5015	C3 6201	A3 6209	B1 6217	B2 7206	C1 9207	A5 9217	C4 9225	D4
1205	A5 2201	A1 2209	B3 3203	A2 3214	A3 3224	B4 5008	C4 5016	C3 6202	A3 6210	B4 6218	B2 8201	D1 9210	A3 9218	C4 9226	D4
1206	B5 2202	A4 2210	A2 3204	A2 3215	A2 5001	D3 5009	C4 5017	C2 6203	B1 6211	A3 6219	B2 9201	A5 9211	C2 9219	C4 9227	D4
1207	D1 2203	A2 2211	B1 3205	B1 3216	C1 5002	D3 5010	C4 5201	A4 6204	B1 6212	B1 7201	A2 9202	B5 9212	C3 9220	C4 9228	D5
1208	B5 2204	A1 2212	B2 3206	B2 3217	D2 5003	D3 5011	C4 5202	A1 6205	A2 6213	B1 7202	A2 9203	A5 9213	C3 9221	D3 9229	A5
1209	B1 2205	A2 2213	B4 3207	B3 3218	C2 5004	D3 5012	C3 5203	A4 6206	A3 6214	A3 7203	C2 9204	B5 9214	C3 9222	D3 9230	B2
1210	B5 2206	A4 2214	A2 3208	A2 3220	B2 5005	D4 5013	C3 5204	A3 6207	B2 6215	C1 7204	A3 9205	C5 9215	C3 9223	D3	

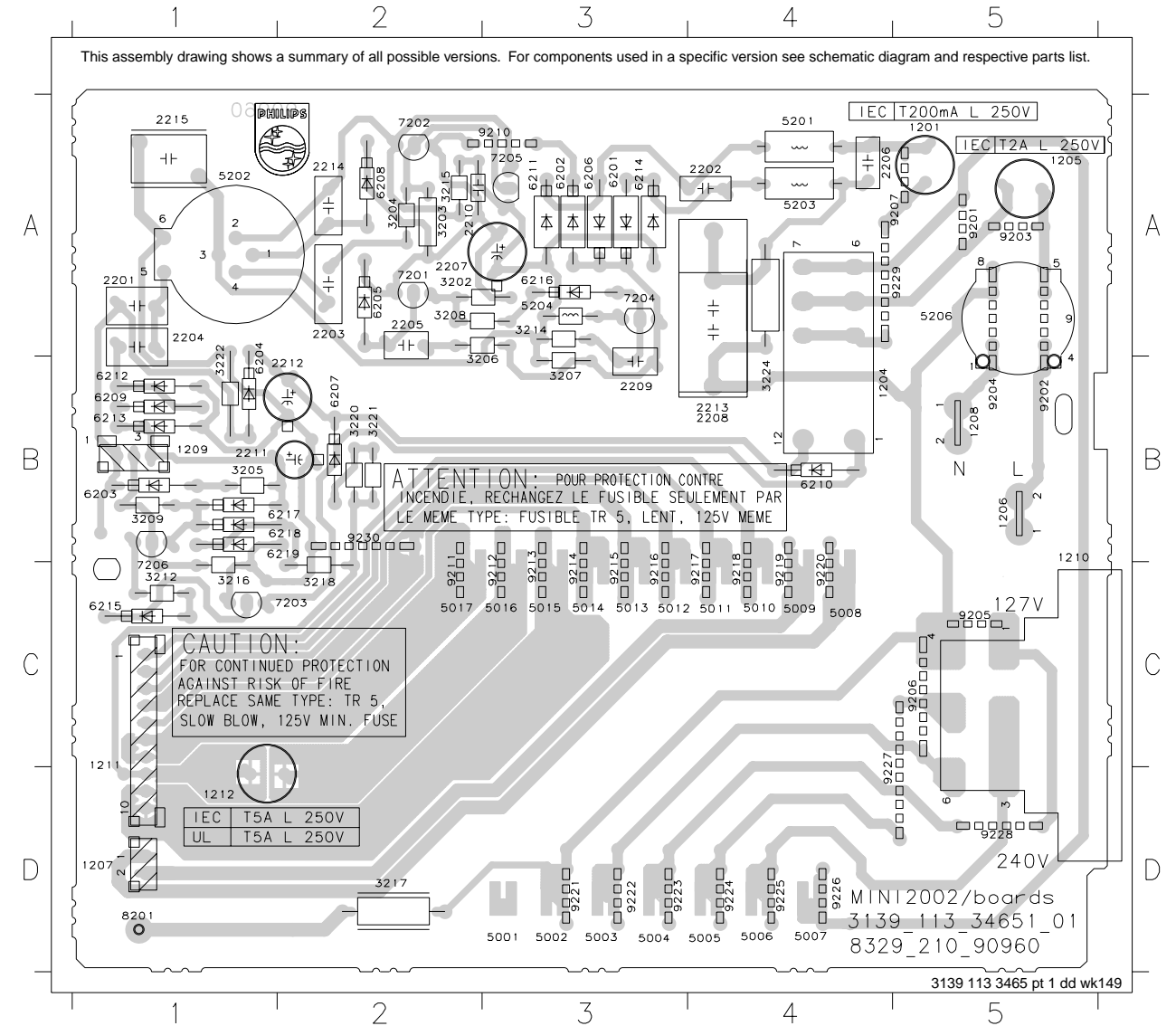

ELECTRICAL PARTS LIST - MAINS BOARD

MISCELLANEOUS

1205	9965 000 07788	△	Fuse T2A 250V
1210	2422 129 16478	△	Voltage Selector 5A
1212	4822 071 55002	△	Fuse T5A 250V

COILS & FILTERS

5206	4822 157 11832	△	Mains Filter 400µH 3A
------	----------------	---	-----------------------

Note: Only the parts mentioned in this list are normal service spare parts.

MAINS CIRCUIT

- | | | | | | | | | | | | | | | | | | | | | |
|---------|---------|---------|---------|---------|----------|---------|---------|---------|---------|----------|----------|----------|---------|---------|----------|---------|---------|---------|---------|---------|
| 1201 A3 | 1207 C5 | 1211 E6 | 2203 A8 | 2207 A6 | 2211 B9 | 2215 B9 | 3205 A9 | 3209 B1 | 3216 B1 | 3221 A2 | 5202 A8 | 6201 A5 | 6205 A6 | 6209 A9 | 6213 B10 | 6217 A1 | 7202 A7 | 7206 B1 | 9203 C2 | 9207 A3 |
| 1204 C3 | 1208 D1 | 1212 E5 | 2204 A9 | 2208 A3 | 2212 B10 | 3202 A6 | 3206 A5 | 3212 B2 | 3217 D1 | 3222 A10 | 5203 A4 | 6202 A5 | 6206 A5 | 6210 A3 | 6214 B5 | 6218 A1 | 7203 B2 | 8201 E1 | 9204 D1 | |
| 1205 C2 | 1209 C6 | 2201 A9 | 2205 A6 | 2209 A6 | 2213 B3 | 3203 A7 | 3207 A5 | 3214 B6 | 3218 A2 | 3224 B3 | 5204 B5 | 6203 A10 | 6207 A3 | 6211 A5 | 6215 B2 | 6219 A2 | 7204 B5 | 9201 C3 | 9205 E2 | |
| 1206 C1 | 1210 E2 | 2202 A4 | 2206 A4 | 2210 A8 | 2214 B8 | 3204 A7 | 3208 B6 | 3215 B8 | 3220 A2 | 5201 A4 | 6204 A10 | 6208 A8 | 6212 B9 | 6216 B6 | 7201 A6 | 7205 B7 | 9202 C1 | 9206 E2 | | |

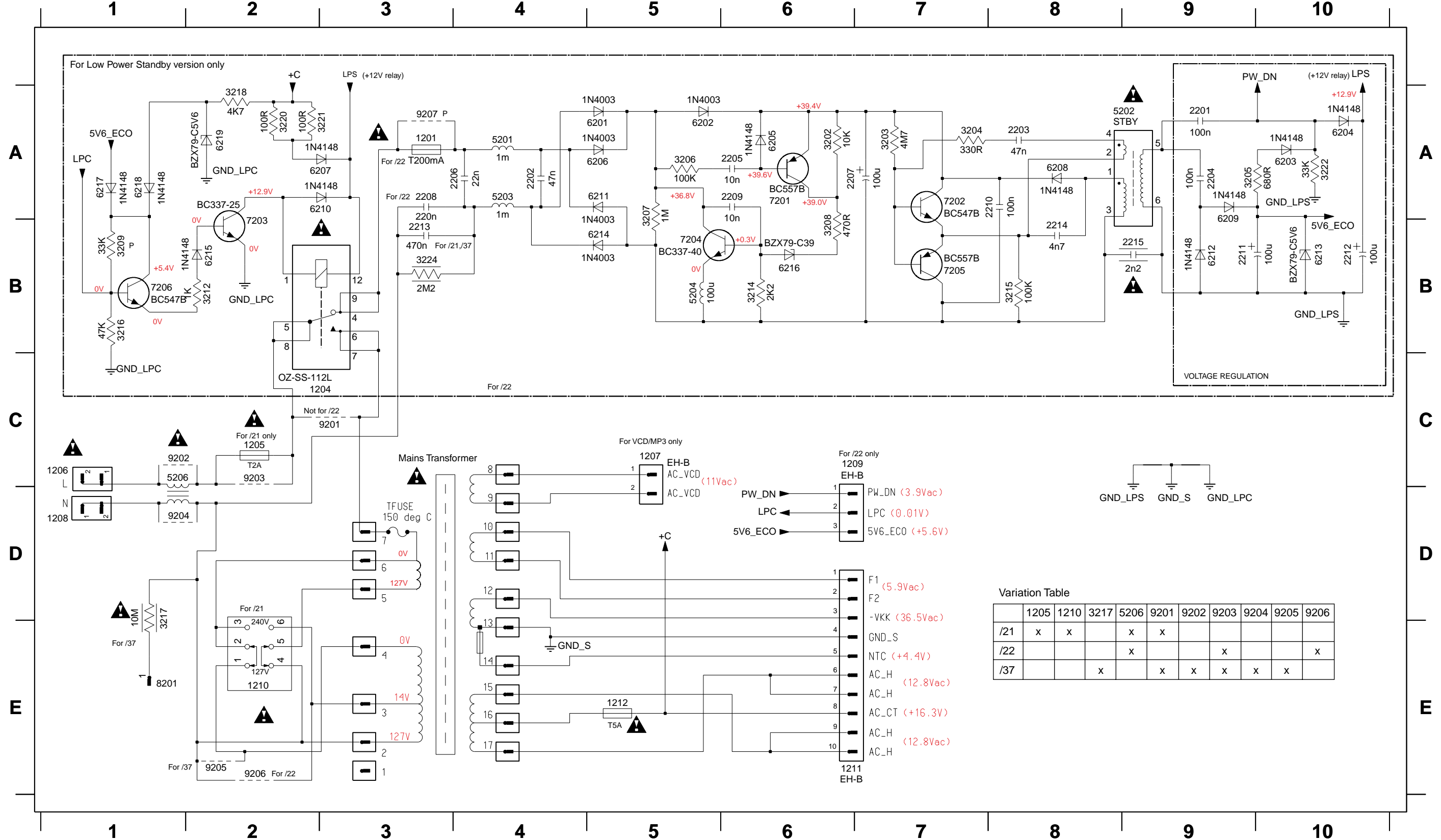

ECO MTF MODULE

TABLE OF CONTENTS

Block Diagram	9-1
Circuit Diagram	9-2
Component Layout	9-3
Adjustment Table	9-3
Exploded Views & Mechanical Parts Lists	9-4
Electrical parts list	9-5

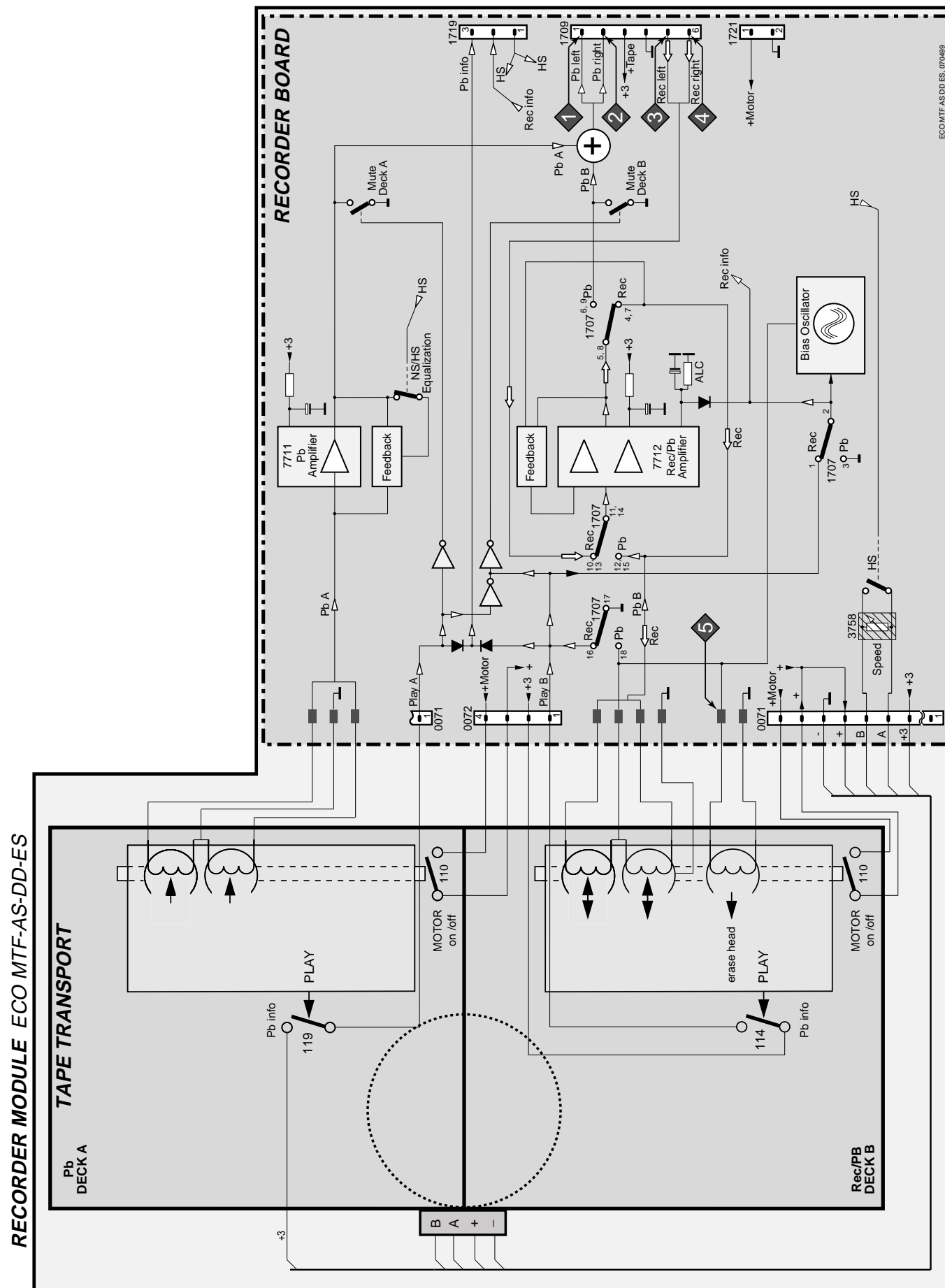

0071 E14	1707-F E7	2702 G8	2709 A5	2716 D6	2724 G8	2732 F5	2741 B6	2749 H3	2759 D2	3704 F13	3712 H7	3719 F6	3727 H6	3734 D5	3742 B4	3750 H3	3758 F13	3766 D8	3773 C10	3780 B4	3789 E2	6707 E12	7710 C6	7715 C8
0072 F14	1709 A14	2703 G13	2710 C4	2718 H5	2725 E6	2733 F3	2742 B5	2751 E4	2760 D2	3705 G13	3713 D2	3720 F6	3728 I7	3735 C6	3743 B3	3752 I3	3759 F10	3767 E8	3774 C10	3781 F6	3790 D9	6708 D12	7711-A B4	7716 E8
1707-A F9	1710 B14	2704 I4	2711 C3	2719 F5	2726 H7	2735 H7	2743 D3	2752 H5	2761 G4	3706 I4	3714 D2	3721 F4	3729 H6	3736 B6	3745 C4	3753 E5	3760 F11	3768 B8	3775 D11	3782 H6	3791 D9	6709 D11	7711-B F4	7717 B9
1707-B E5	1719 D14	2705 I10	2712 I3	2720 F9	2727 G5	2737 H6	2744 C4	2753 C8	2762 I4	3707 I11	3715 G4	3722 F3	3730 H6	3737 E4	3746 C3	3754 C7	3761 G12	3769 C9	3776 D12	3785 G10	3792 E9	6710 F12	7712-A B4	7718 C10
1707-C G6	1721 G14	2706 G3	2713 E4	2721 I10	2728 F7	2738 H5	2745 B3	2754 C9	2763 I4	3708 H10	3716 F5	3724 G3	3731 F4	3738 D3	3747 B5	3755 B7	3763 H12	3770 B10	3777 C12	3786 H11	3793 G9	6711 F12	7712-B F4	7719 C12
1707-D G2	1780 D14	2707 E8	2714 H4	2722 H10	2730 F6	2739 D5	2747 C5	2755 C10	2764 I4	3709 G10	3717 F6	3725 G5	3732 D6	3740 E4	3748 A5	3756 C7	3764 B8	3771 E12	3778 G11	3787 H10	3794 I5	6712 G12	7713 B8	7722 D9
1707-E E2	2701 G8	2708 E3	2715 B6	2723 G10	2731 F5	2740 D6	2748 H5	2756 C11	2765 F12	3711 E7	3718 F7	3726 G4	3733 C6	3741 E3	3749 I4	3757 D7	3765 C8	3772 F12	3779 F11	3788 E2	6706 F12	6709 D6	7714 C8	9730 G9

RECORDER BOARD

ECO MTF AS

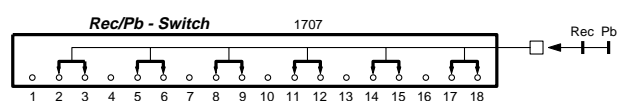
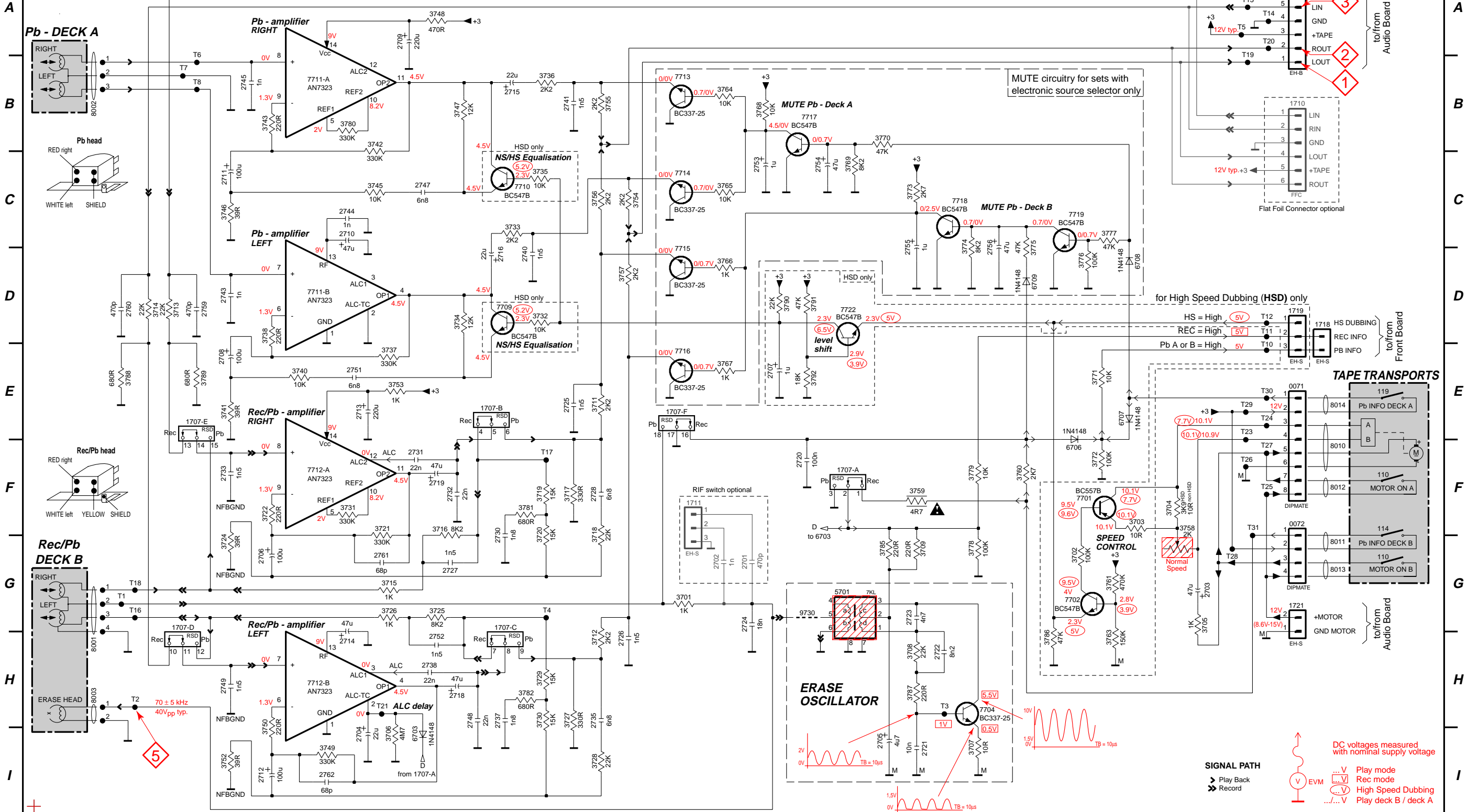

SIGNAL PATH

- ▶ Play Back
- Record

DC voltages measured with nominal supply voltage

- ...V Play mode
- ...V Rec mode
- ...V High Speed Dubbing
- ...V Play deck B / deck A

EXPLODED VIEW / RECORDER MODULE

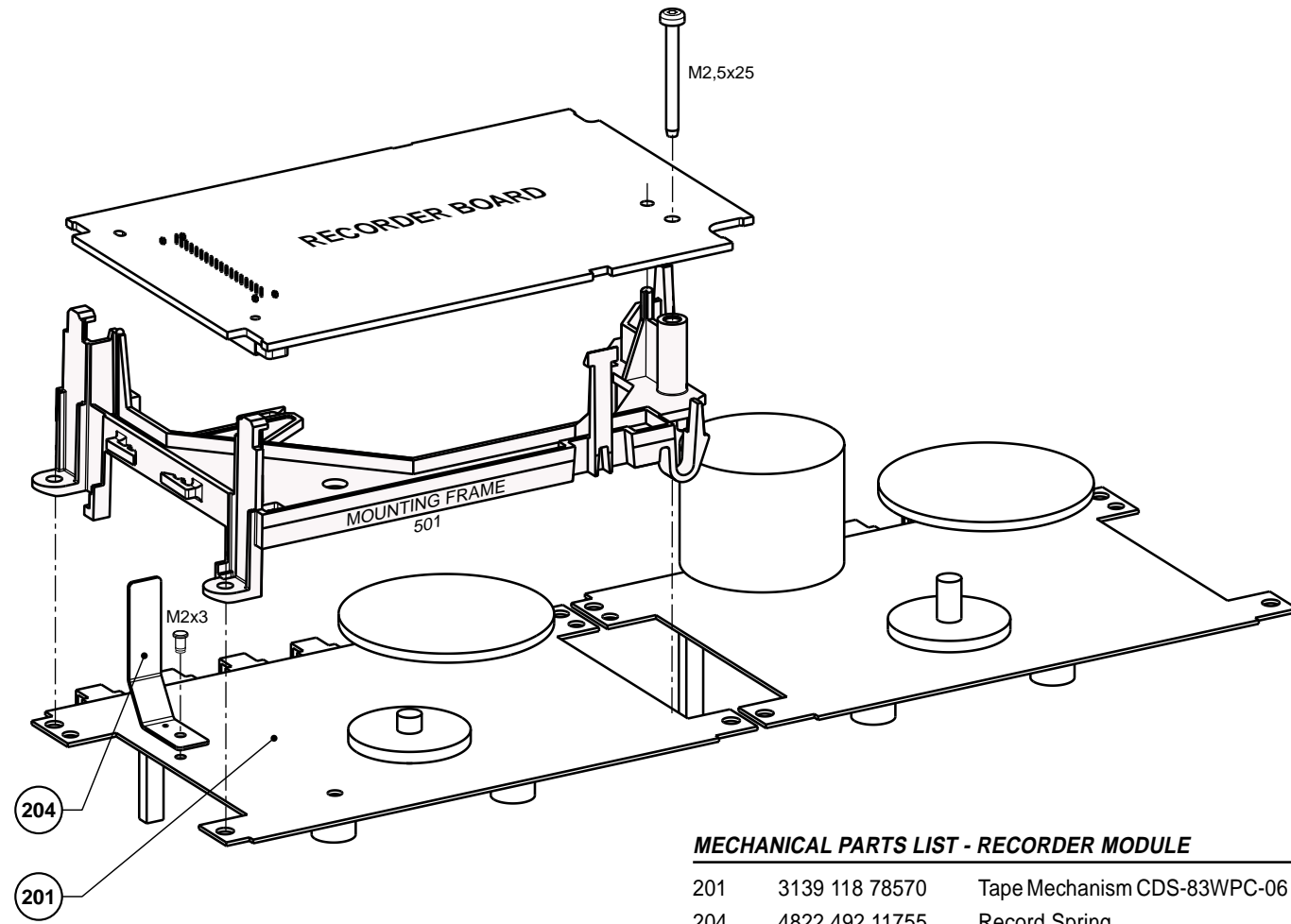

MECHANICAL PARTS LIST - RECORDER MODULE

201	3139 118 78570	Tape Mechanism CDS-83WPC-06
204	4822 492 11755	Record Spring

Note: Only the parts mentioned in this list are normal service spare parts.

MECHANICAL PARTS LIST - TAPE TRANSPORT

10-12	4822 528 11189	Pinch Roller Assembly	118	4822 466 11787	Motor Cushion
106	4822 358 31225	Main Belt	119	4822 277 11753	Leaf Switch
107	4822 358 31124	Sub Belt	122	4822 532 12937	Washer PSW-S 1.6X3.5X0.4
110	4822 278 90663	Leaf Switch, Motor On/Off	17-24	4822 402 10966	FR Arm Assembly
111	4822 249 10565	Rec/PB Head, TC951-B	38-41	9965 000 08765	Flywheel Assembly, Play Deck
112	9965 000 02600	Erase Head	39-41	9965 000 08766	Flywheel Assembly, Rec/PB Deck
113	4822 249 10565	Rec/PB HEAD, TC951-B			
114	4822 276 13712	Leaf Switch LSA1115B			
115-116	4822 361 11053	Motor Assembly			

Note: Only the parts mentioned in this list are normal service spare parts.

EXPLODED VIEW TAPE TRANSPORT

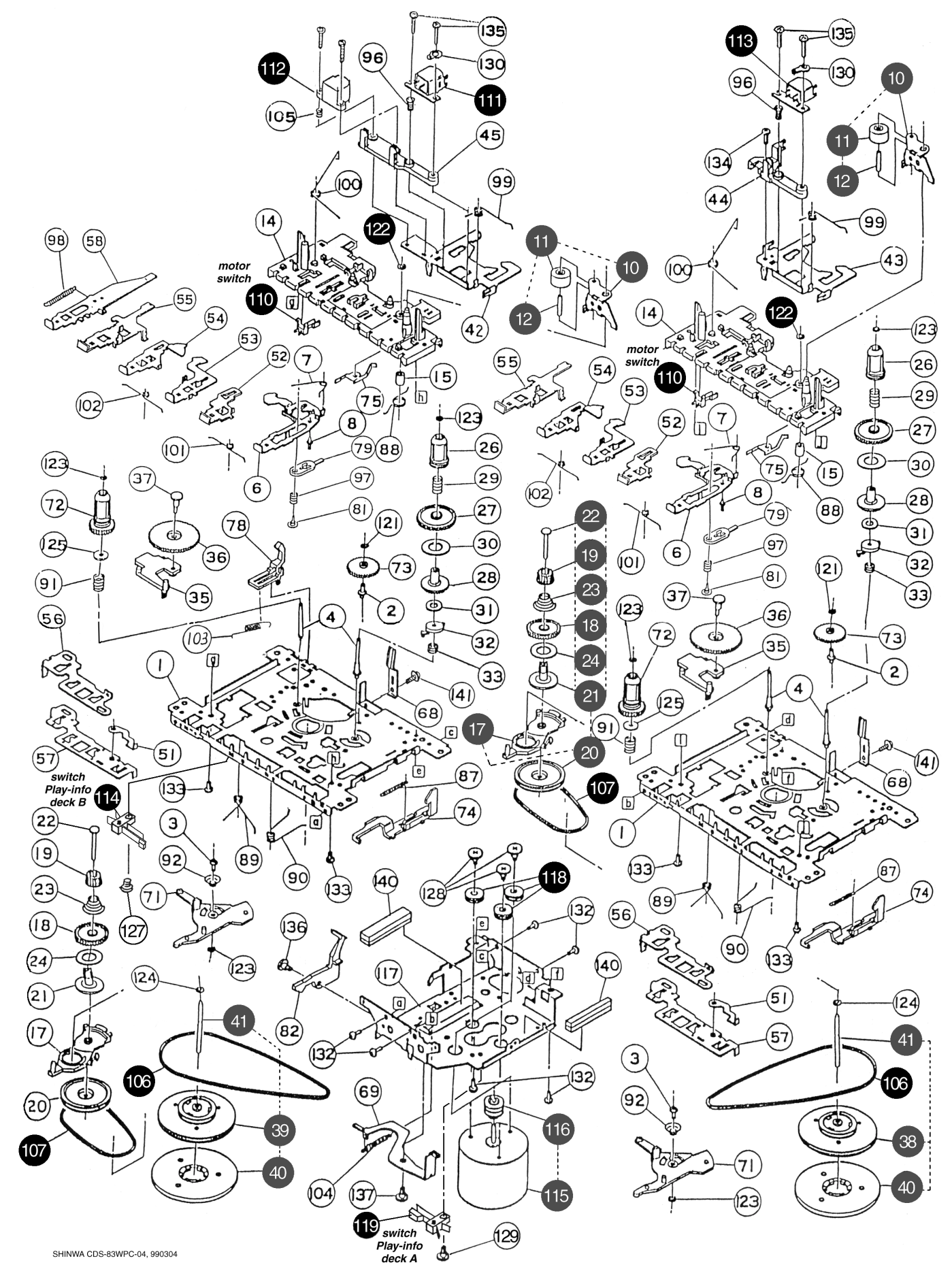

ELECTRICAL PARTS LIST - ECO MTF BOARD**MISCELLANEOUS**

1707	4822 277 11504	Rec/PB Slide Switch	2761	4822 126 10329	68pF 5%
1710	4822 265 11207	Flex Socket 6pin Hort.	2762	4822 126 10329	68pF 5%

CAPACITORS

2703	4822 124 40433	47µF 20% 25V
2704	4822 124 81151	22µF 50V
2705	4822 124 40769	4,7µF 20% 100V
2706	4822 124 41584	100µF 20% 10V
2707	4822 124 21913	1µF 20% 63V HSD only
2708	4822 124 41584	100µF 20% 10V
2709	4822 124 40196	220µF 20% 16V
2710	4822 124 40433	47µF 20% 25V
2711	4822 124 23432	100µF 20% 10V
2712	4822 124 41584	100µF 20% 10V
2713	4822 124 40196	220µF 20% 16V
2714	4822 124 40433	47µF 20% 25V
2715	4822 124 81151	22µF 50V
2716	4822 124 81151	22µF 50V
2718	4822 124 40433	47µF 20% 25V
2719	4822 124 40433	47µF 20% 25V
2720	4822 126 12882	100nF +80/-20% 50V
2721	4822 121 41857	10nF 5% 250V
2722	4822 126 13307	8,2nF 10% 16V
2723	4822 121 10686	4,7nF 10% 50V
2724	4822 121 43179	18nF 5% 100V
2725	4822 126 12878	1,5nF 10% 16V
2726	4822 126 12878	1,5nF 10% 16V
2727	4822 126 12878	1,5nF 10% 16V
2728	4822 121 10746	6,8nF 10% 50V
2730	4822 121 10685	1,8nF 10% 50V
2731	4822 126 11585	22nF +80/-20% 25V
2732	4822 126 11585	22nF +80/-20% 25V
2733	4822 126 12878	1,5nF 10% 16V
2735	4822 121 10746	6,8nF 10% 50V
2737	4822 121 10685	1,8nF 10% 50V
2738	4822 126 11585	22nF +80/-20% 25V
2740	4822 126 12878	1,5nF 10% 16V
2741	4822 126 12878	1,5nF 10% 16V
2743	4822 122 33197	1nF 10% 50V
2744	4822 122 33197	1nF 10% 50V
2745	4822 122 33197	1nF 10% 50V
2747	4822 121 10746	6,8nF 10% 50V
2748	4822 126 11585	22nF +80/-20% 25V
2749	4822 126 12878	1,5nF 10% 16V
2751	4822 121 10746	6,8nF 10% 50V
2752	4822 126 12878	1,5nF 10% 16V
2753	4822 124 21913	1µF 20% 63V
2754	4822 124 40433	47µF 20% 25V
2755	4822 124 21913	1µF 20% 63V
2756	4822 124 40433	47µF 20% 25V
2759	4822 122 33519	470pF 10% 50V
2760	4822 122 33519	470pF 10% 50V

RESISTORS

3701	4822 050 11002	1k 1% 0,4W
3702	4822 116 52234	100k 5% 0,5W HSD only
3703	4822 116 52176	10R 5% 0,5W HSD only
3704	4822 116 52176	10R 5% 0,5W non-HSD only
3704	4822 116 52276	3k9 5% 0,5W HSD only
3705	4822 050 11002	1k 1% 0,4W
3706	4822 050 24705	4M7 1% 0,6W
3707	4822 116 52176	10R 5% 0,5W
3708	4822 116 52257	22k 5% 0,5W
3709	4822 116 83872	220R 5% 0,5W
3711	4822 116 52256	2k2 5% 0,5W
3712	4822 116 52256	2k2 5% 0,5W
3713	4822 116 52257	22k 5% 0,5W
3714	4822 116 52257	22k 5% 0,5W
3715	4822 050 11002	1k 1% 0,4W
3716	4822 116 52303	8k2 5% 0,5W
3717	4822 116 52219	330R 5% 0,5W
3718	4822 116 52257	22k 5% 0,5W
3719	4822 116 52244	15k 5% 0,5W
3720	4822 116 52244	15k 5% 0,5W
3721	4822 116 52272	330k 5% 0,5W
3722	4822 116 83872	220R 5% 0,5W
3724	4822 116 52193	39R 5% 0,5W
3725	4822 116 52303	8k2 5% 0,5W
3726	4822 050 11002	1k 1% 0,4W
3727	4822 116 52219	330R 5% 0,5W
3728	4822 116 52257	22k 5% 0,5W
3729	4822 116 52244	15k 5% 0,5W
3730	4822 116 52244	15k 5% 0,5W
3731	4822 116 52272	330k 5% 0,5W
3732	4822 050 21003	10k 1% 0,6W HSD only
3733	4822 116 52256	2k2 5% 0,5W
3734	4822 116 52238	12k 5% 0,5W
3735	4822 050 21003	10k 1% 0,6W HSD only
3736	4822 116 52256	2k2 5% 0,5W
3737	4822 116 52272	330k 5% 0,5W
3738	4822 116 83872	220R 5% 0,5W
3740	4822 050 21003	10k 1% 0,6W
3741	4822 116 52193	39R 5% 0,5W
3742	4822 116 52272	330k 5% 0,5W
3743	4822 116 83872	220R 5% 0,5W
3745	4822 050 21003	10k 1% 0,6W
3746	4822 116 52193	39R 5% 0,5W
3747	4822 116 52238	12k 5% 0,5W
3748	4822 116 83883	470R 5% 0,5W
3749	4822 116 52272	330k 5% 0,5W
3750	4822 116 83872	220R 5% 0,5W
3752	4822 116 52193	39R 5% 0,5W

ELECTRICAL PARTS LIST - ECO MTF BOARD**RESISTORS**

3753	4822 050 11002	1k 1% 0,4W	7709	4822 130 40959	BC547B	HSD only
3754	4822 116 52256	2k2 5% 0,5W	7710	4822 130 40959	BC547B	HSD only
3755	4822 116 52256	2k2 5% 0,5W	7711	4822 209 17498	AN7323	
3756	4822 116 52256	2k2 5% 0,5W	7712	4822 209 17498	AN7323	
3757	4822 116 52256	2k2 5% 0,5W	7713	4822 130 40981	BC337-25	
3758	4822 100 11368	Potm Trim 2K 30%	7714	4822 130 40981	BC337-25	
3759	4822 052 10478	4R7 5% 0,33W	7715	4822 130 40981	BC337-25	
3760	4822 116 52263	2k7 5% 0,5W	7716	4822 130 40981	BC337-25	
3761	4822 116 52285	470k 5% 0,5W HSD only	7717	4822 130 40959	BC547B	
3763	4822 116 52245	150k 5% 0,5W HSD only	7718	4822 130 40959	BC547B	
3764	4822 050 21003	10k 1% 0,6W	7719	4822 130 40959	BC547B	
3765	4822 050 21003	10k 1% 0,6W	7722	4822 130 40959	BC547B	HSD only
3766	4822 050 11002	1k 1% 0,4W				
3767	4822 050 11002	1k 1% 0,4W				
3768	4822 050 21003	10k 1% 0,6W				
3769	4822 116 52303	8k2 5% 0,5W				
3770	4822 116 83884	47k 5% 0,5W				
3771	4822 050 21003	10k 1% 0,6W				
3772	4822 116 52234	100k 5% 0,5W				
3773	4822 116 52263	2k7 5% 0,5W				
3774	4822 116 52303	8k2 5% 0,5W				
3775	4822 116 83884	47k 5% 0,5W				
3776	4822 116 52234	100k 5% 0,5W				
3777	4822 116 83884	47k 5% 0,5W				
3778	4822 116 52234	100k 5% 0,5W				
3779	4822 050 21003	10k 1% 0,6W				
3780	4822 116 52272	330k 5% 0,5W				
3781	4822 116 52228	680R 5% 0,5W				
3782	4822 116 52228	680R 5% 0,5W				
3785	4822 116 83872	220R 5% 0,5W				
3786	4822 116 83884	47k 5% 0,5W HSD only				
3787	4822 116 83872	220R 5% 0,5W				
3788	4822 116 52228	680R 5% 0,5W				
3789	4822 116 52228	680R 5% 0,5W				
3790	4822 116 52257	22k 5% 0,5W HSD only				
3791	4822 116 83884	47k 5% 0,5W HSD only				
3792	4822 116 52251	18k 5% 0,5W HSD only				

Note: Only the parts mentioned in this list are normal service spare parts.

COILS & FILTERS

5701	4822 157 10371	Oscillator coil
------	----------------	-----------------

DIODES

6703	4822 130 30621	1N4148
6706	4822 130 30621	1N4148
6707	4822 130 30621	1N4148
6708	4822 130 30621	1N4148
6709	4822 130 30621	1N4148

TRANSISTORS & INTEGRATED CIRCUITS

7701	4822 130 44568	BC557B	HSD only
7702	4822 130 44568	BC557B	HSD only
7704	4822 130 40981	BC337-25	



3CDC-LLC-MCD1

(3 Disc Carousel Changer)

Layout stage .3

TABLE OF CONTENTS

Service Hints	10-2
Blockdiagram	10-5
Component Layout Main Board	10-6
Circuit Diagram part1	10-7
Component Layout Main Board	10-8
Circuit Diagram part2	10-9
Exploded View	10-10
Partslist	10-12



Service hints

CAUTION

CHARGED CAPACITORS ON THE SERVO BOARD MAY DAMAGE THE CD DRIVE ELECTRONICS WHEN CONNECTING A NEW CD MECHANISM. THAT'S WHY, BESIDES THE SAFETY MEASURES LIKE

- **SWITCH OFF POWER SUPPLY**
- **ESD PROTECTION**

ADDITIONAL ACTIONS MUST BE TAKEN BY THE REPAIR TECHNICIAN.

The following steps have to be done when replacing the CD mechanism:

1. Disconnect flexfoil cable from the old CD drive
2. Put a paperclip on the flexfoil to short-circuit the contacts (fig.1)
3. Remove the old CD drive
4. Remove paperclip from the flexfoil and connect it to the new drive
5. Position the new CD drive in its studs
6. Remove solder joint from the Laserunit

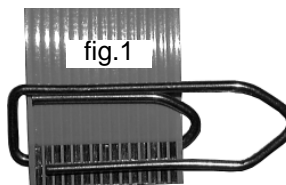

Attention: The laser diode of this CD drive is protected against ESD by a solder joint which shortcircuits the laserdiode to ground.

For proper functionality of the CD drive this solder joint must be removed **after** connection the drive to the set.

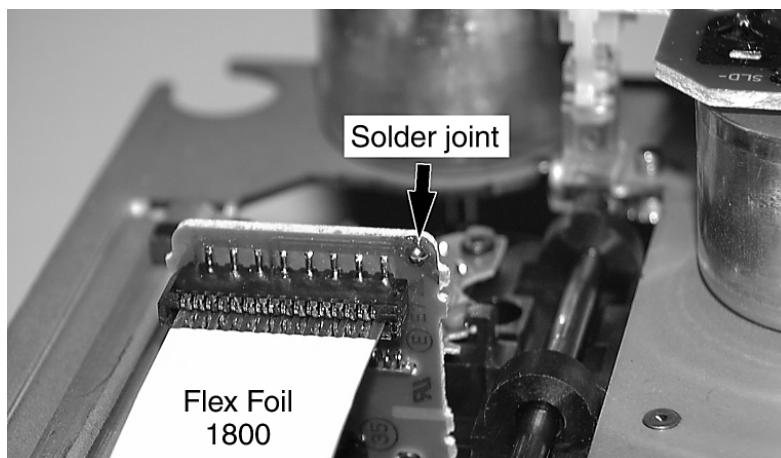

Emergency open

In case of a Supply fault, the tray can be opened manually.

1. Remove the top cover of the set to get access to the Changer Module.
2. Turn gearwheel clockwise (as shown in picture below).

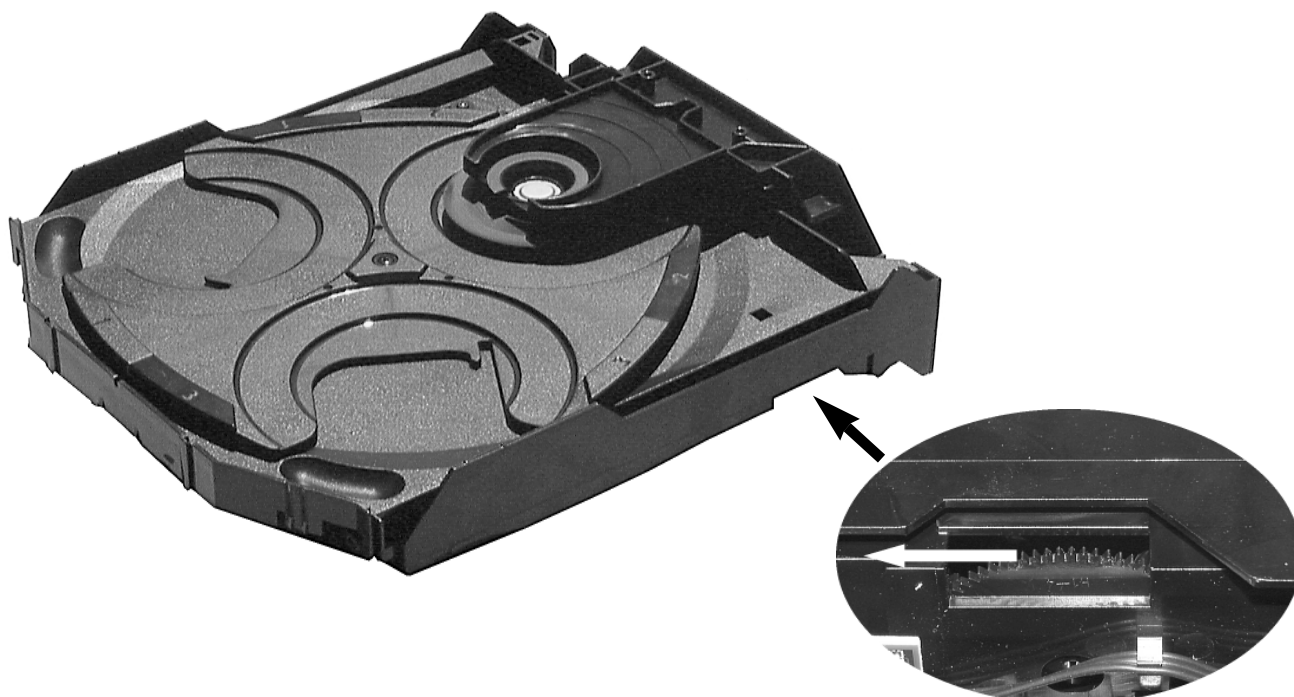

Service hints

Dismantling of Tray

1. Open the tray.
2. Release 2x catch as shown in fig. 2 and Detail A
3. Pull tray out.

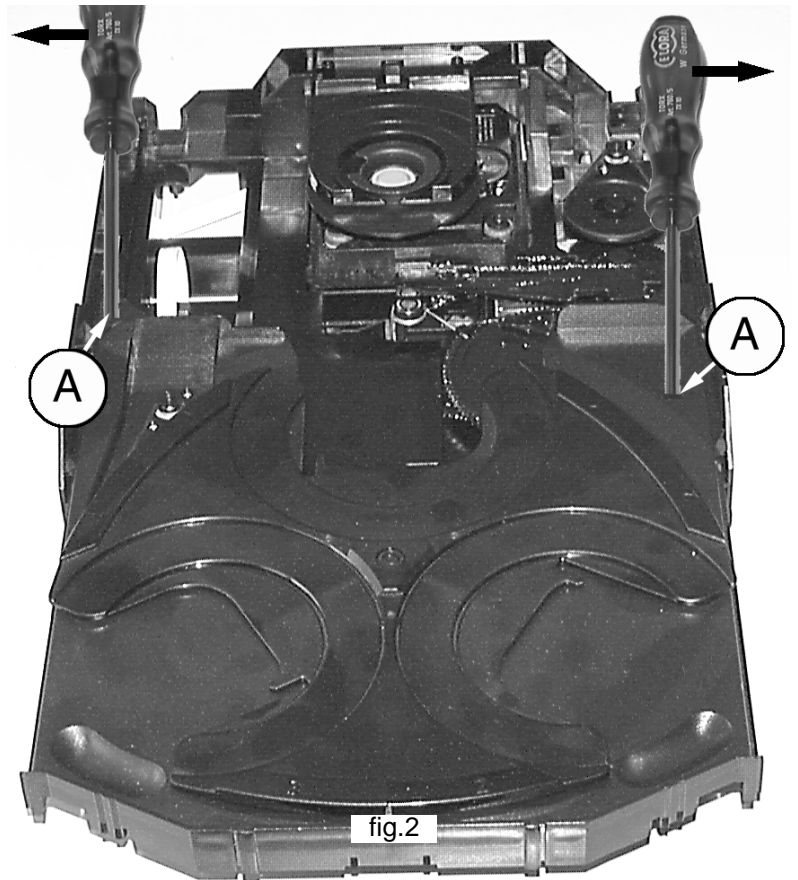
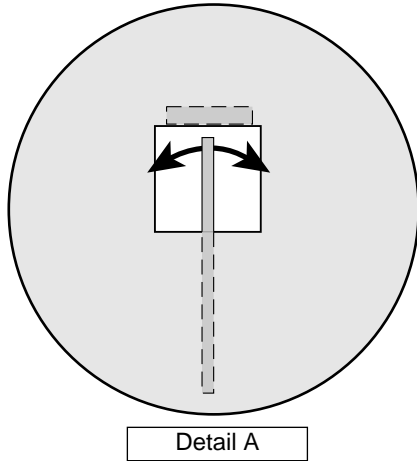

Assembling of Tray

1. Turn Cam (pos. 48) clockwise to end position.
2. If necessary - move Guiding (pos. 49) to the right end position.
3. Insert the Tray.

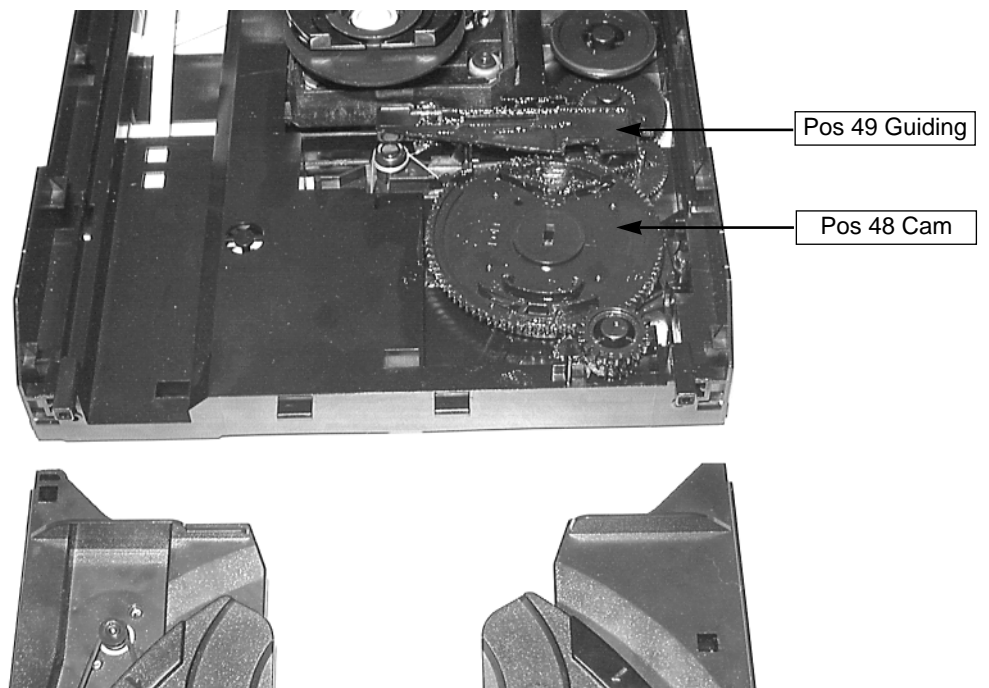

Service Position

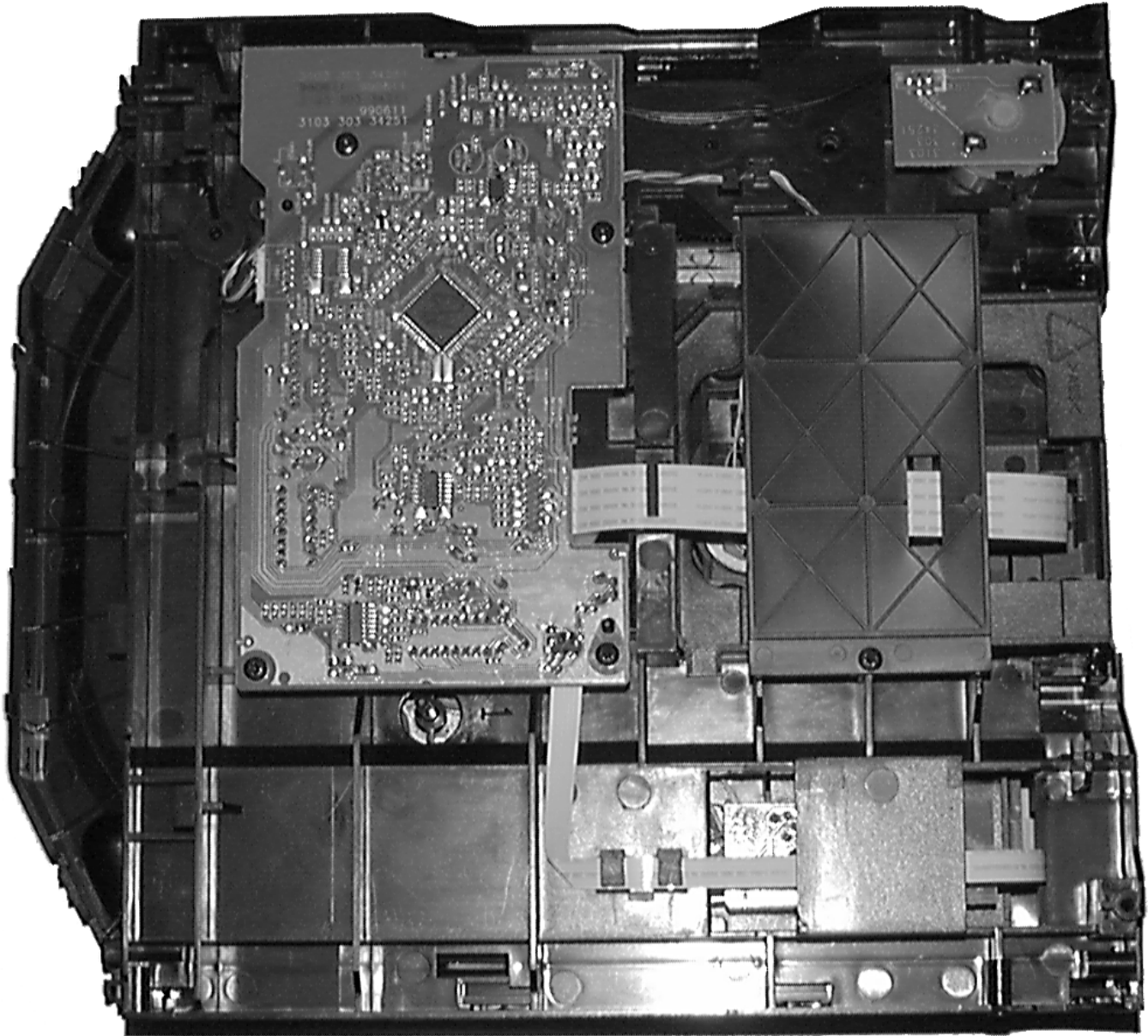

BLOCK DIAGRAM 3CDC-LLC-MCD1

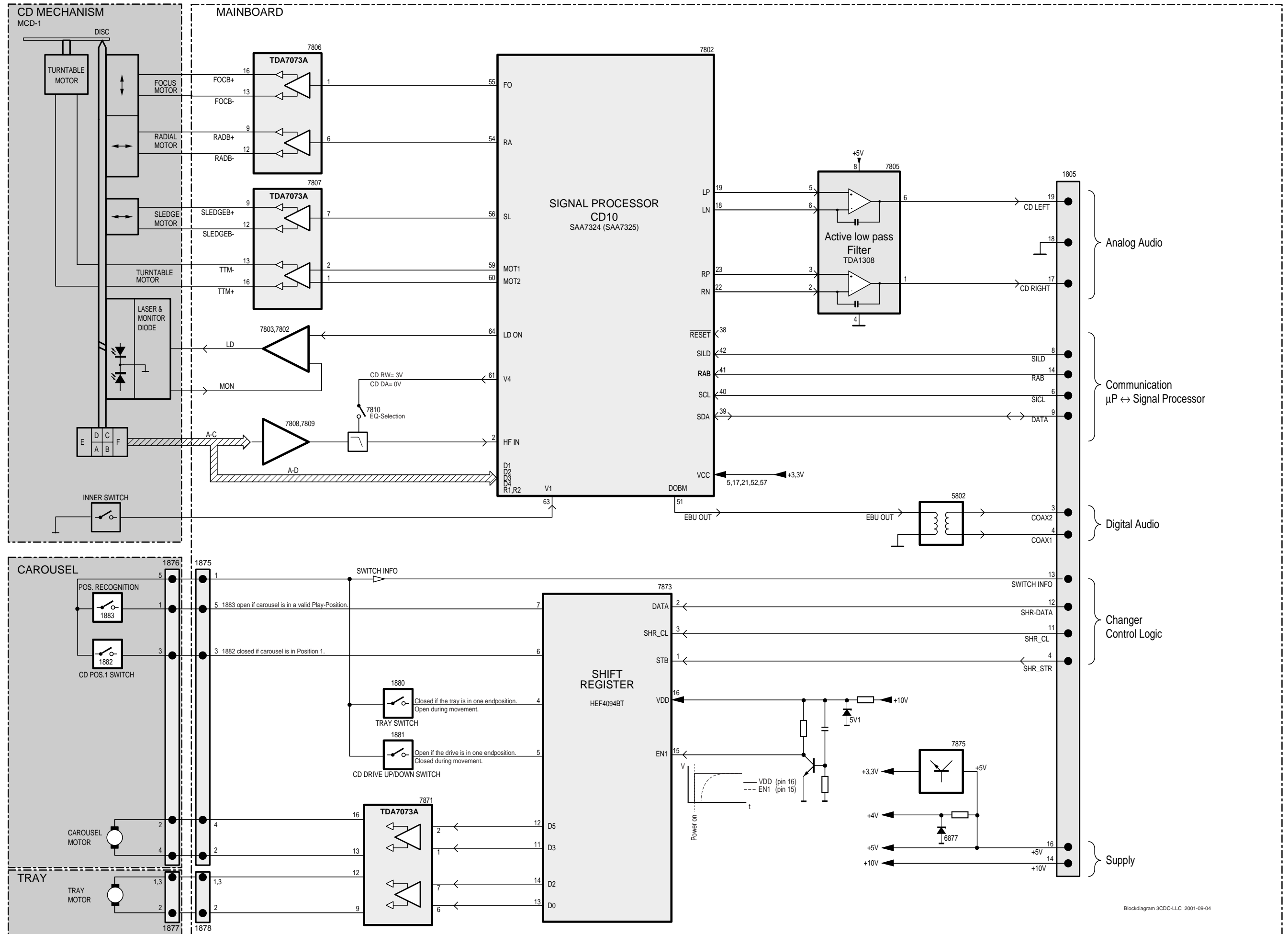

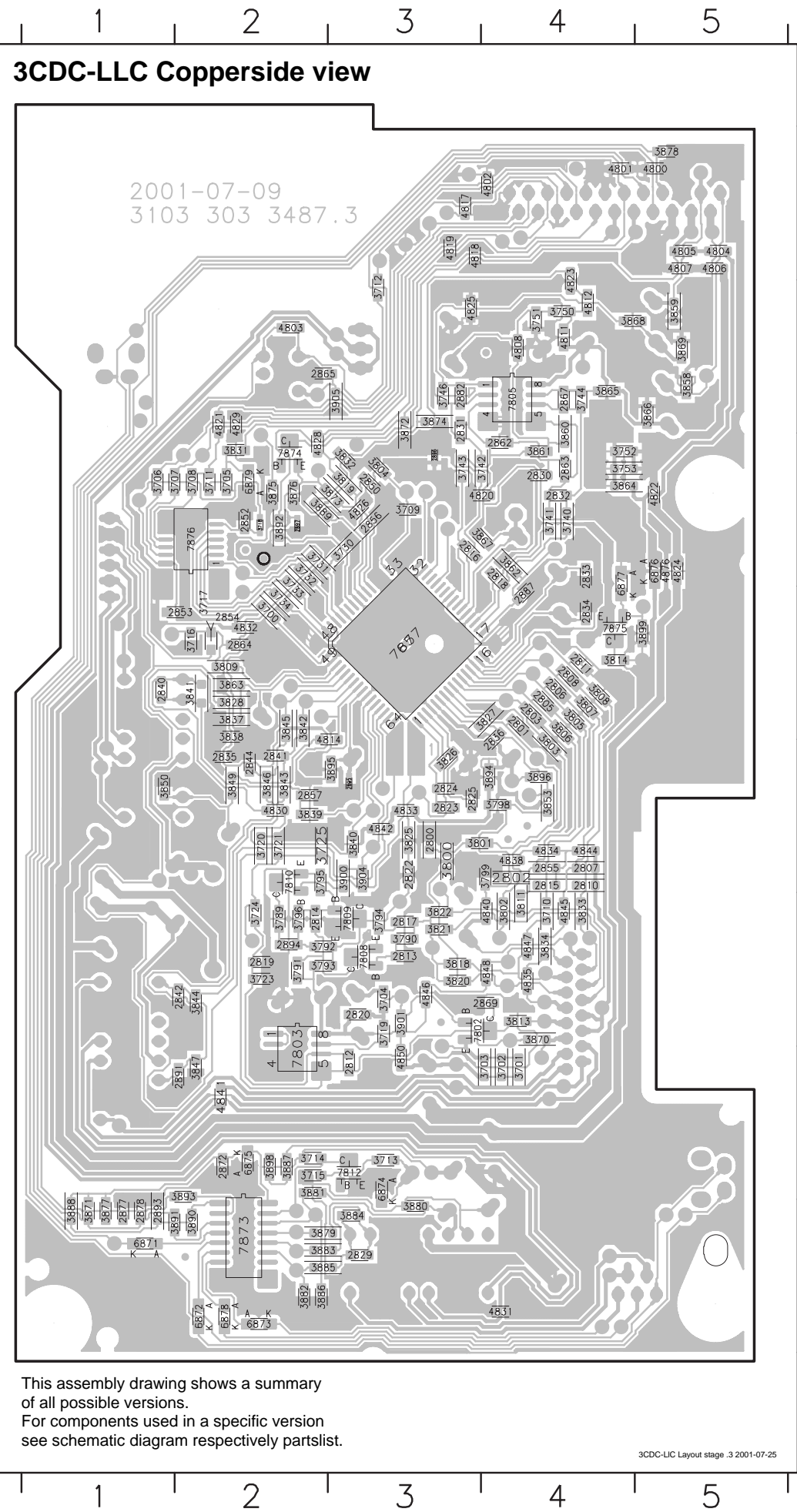

Mapping

Copperside		Componentside	
2800 E3	3741 C4	3889 C2	1800 F2
2801 D4	3742 C4	3890 H2	1801 C5
2802 E4	3743 C3	3891 H2	1805 A2
2803 D4	3744 B4	3892 C2	1810 C2
2805 D4	3746 B3	3893 G2	1875 H1
2806 D4	3750 B4	3894 E4	1878 B3
2807 E4	3751 B4	3895 E3	1880 B5
2808 D4	3752 C4	3896 E4	1881 G1
2810 E4	3753 C4	3898 G2	2804 F3
2811 D4	3789 F2	3899 D5	2809 E4
2812 G3	3790 F3	3900 E3	2826 D3
2813 F3	3791 F2	3901 F3	2828 D4
2814 F2	3792 F3	3904 E3	2837 E5
2815 E4	3793 F3	3905 B3	2838 F2
2816 C3	3794 F3	4800 A5	2839 E5
2817 F3	3795 E2	4801 A4	2851 C2
2818 C4	3796 F2	4802 A4	2858 B2
2819 F2	3798 E4	4803 B2	2860 B1
2820 F3	3799 E4	4804 A5	2861 B1
2822 E3	3800 E3	4805 A5	2873 H2
2823 E3	3801 E4	4806 A5	2875 G3
2824 E3	3802 F4	4807 A5	2876 B2
2825 E3	3803 D4	4808 B4	2881 G3
2829 H3	3804 C3	4811 B4	2885 D2
2830 C4	3805 D4	4812 B4	2888 F4
2831 B3	3806 D4	4814 D3	3812 F4
2832 C4	3807 D4	4817 A3	3815 G3
2833 C4	3808 D4	4818 A3	3835 F5
2834 D4	3809 D2	4819 A3	3851 G2
2835 E2	3811 F4	4820 C4	3852 E5
2836 D4	3813 F4	4821 B2	5802 B4
2840 D1	3814 D4	4822 C5	7806 F5
2841 E2	3818 F3	4823 A4	7807 D5
2842 F2	3819 C3	4824 C5	7871 H3
2844 E2	3820 F3	4825 B3	
2850 C3	3821 F3	4826 C3	
2852 C2	3822 F3	4828 C2	
2853 D2	3825 E3	4829 B2	
2854 D2	3826 E3	4830 E2	
2855 E4	3827 D4	4831 H4	
2856 C3	3828 D2	4832 D2	
2857 E2	3831 C2	4833 E3	
2862 C4	3832 C3	4834 E4	
2863 C4	3833 F4	4835 F4	
2864 D2	3834 F4	4838 E4	
2865 B3	3837 D2	4840 F4	
2867 B4	3838 D2	4841 G2	
2869 F4	3839 E2	4842 E3	
2872 G2	3840 E3	4844 E4	
2877 H1	3841 D2	4845 F4	
2878 H1	3842 D2	4846 F3	
2882 B3	3843 E2	4847 F4	
2887 C4	3844 F2	4848 F4	
2891 G2	3845 D2	4850 G3	
2893 H1	3846 E2	4876 C5	
2894 F2	3847 G2	6871 H1	
2895 E3	3849 E2	6872 H2	
2896 C3	3850 E1	6873 H2	
2897 C2	3853 E4	6874 G3	
3700 D2	3858 B5	6875 G2	
3701 G4	3859 B5	6876 C5	
3702 G4	3860 B4	6877 C4	
3703 G4	3861 C4	6878 H2	
3704 F3	3862 C4	6879 C2	
3705 C2	3863 D2	7802 F4	
3706 C1	3864 C4	7803 F2	
3707 C2	3865 B4	7805 B4	
3708 C2	3866 B5	7808 F3	
3709 C3	3867 C4	7809 F3	
3710 F4	3868 B5	7810 E2	
3711 C2	3869 B5	7812 G3	
3712 A3	3870 F4	7873 H2	
3713 G3	3871 H1	7874 C2	
3714 G2	3872 B3	7875 D4	
3715 G2	3873 C3	7876 C2	
3716 D2	3874 B3	7877 D3	
3717 D2	3875 C2		
3718 C2	3876 C2		
3719 F3	3877 H1		
3720 E2	3878 A5		
3721 E2	3879 H3		
3723 F2	3880 G3		
3724 F2	3881 G2		
3725 E2	3882 H2		
3730 C3	3883 H3		
3731 C2	3884 H3		
3732 C2	3885 H3		
3733 C2	3886 H2		
3734 D2	3887 G2		
3740 C4	3888 H1		

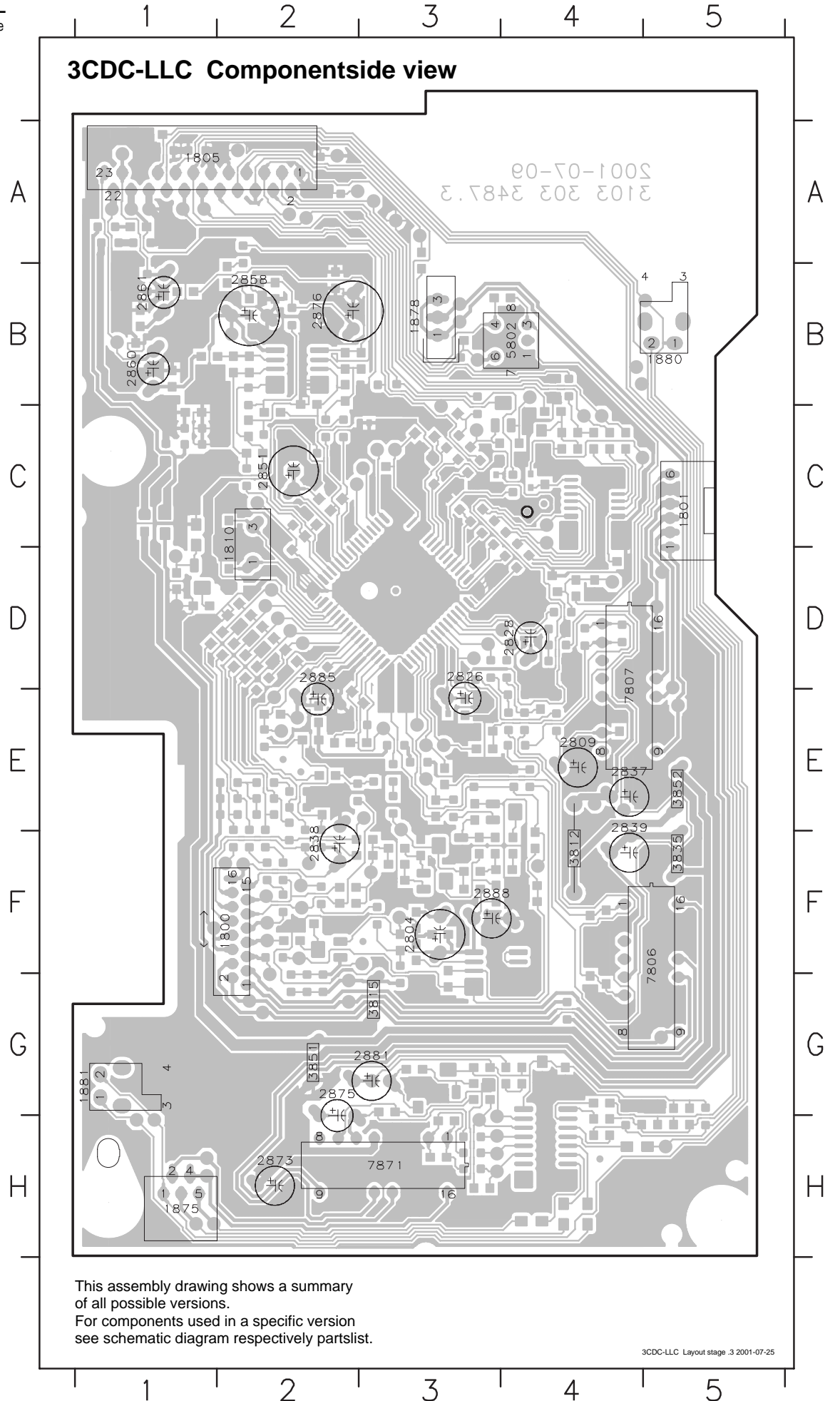

1800 F1	2804 D4	2811 A9	2818 B11	2826 G12	2838 D8	2851 B11	2888 C4	3702 D3	3721 D6	3792 F8	3800 D8	3807 B9	3819 D14	3828 G11	3839 H6	3846 F5	3863 G13	3895 G12	7803-B D5	MP713 C9	MP743 D2	MP813 B3	MP820 F8	MP837 D4	MP844 E9	MP851 E2	MP873 H4	MP884 C5
1801 G1	2805 C8	2812 D5	2819 E5	2828 G13	2839 F4	2855 C8	2891 F4	3703 D3	3723 E6	3793 E8	3801 D8	3808 A9	3820 C3	3832 C15	3840 G5	3847 F5	3867 A11	3896 E9	7806 G3	MP715 D9	MP744 C2	MP814 G2	MP821 C15	MP838 G6	MP845 F4	MP852 G2	MP875 F13	MP893 F10
1810 B10	2806 B8	2813 F7	2820 D4	2833 B10	2840 G4	2856 D15	2894 F8	3704 D4	3724 D6	3794 F7	3802 C8	3811 C8	3821 B3	3833 A8	3841 G5	3849 H5	3870 E2	3900 F9	7807 H3	MP716 B9	MP745 E2	MP815 B3	MP827 B10	MP839 G6	MP846 H2	MP853 G2	MP876 E2	
2800 D8	2807 B8	2814 F7	2822 F9	2834 B10	2841 F5	2857 H5	2895 G12	3709 C14	3725 D6	3795 F8	3803 C8	3812 H4	3822 B3	3834 B8	3842 E6	3850 H5	3873 D14	3901 D4	7808 F7	MP717 A9	MP800 E2	MP816 A3	MP828 G11	MP840 E6	MP847 H2	MP858 G8	MP877 E3	
2801 D8	2808 B9	2815 B8	2823 F10	2835 H7	2842 E5	2869 D3	2896 H12	3710 B8	3789 F8	3796 F8	3804 C14	3813 E2	3825 F9	3835 F5	3843 E5	3852 H5	3889 D15	3904 G10	7809 G8	MP729 B9	MP802 B15	MP817 A3	MP829 A3	MP841 F6	MP848 E2	MP859 E10	MP878 B13	
2802 C8	2809 H4	2816 B12	2824 F10	2836 E10	2844 F5	2885 E9	2897 H12	3719 D4	3790 F7	3798 D8	3805 B8	3815 C4	3826 F9	3837 G7	3844 E5	3853 E9	3892 E15	7802 D3	7810 F9	MP730 C9	MP809 D10	MP818 C4	MP831 A4	MP842 H6	MP849 E2	MP860 C2	MP879 B11	
2803 C8	2810 A8	2817 F7	2825 E9	2837 H4	2850 C14	2887 B10	3701 D3	3720 D5	3791 E7	3799 D8	3806 C8	3818 B3	3827 E10	3838 H7	3845 F6	3862 A10	3894 E9	7803-A B5	7877 D12	MP731 B13	MP812 G2	MP819 F10	MP836 D3	MP843 G7	MP850 E2	MP872 C15	MP883 C4	

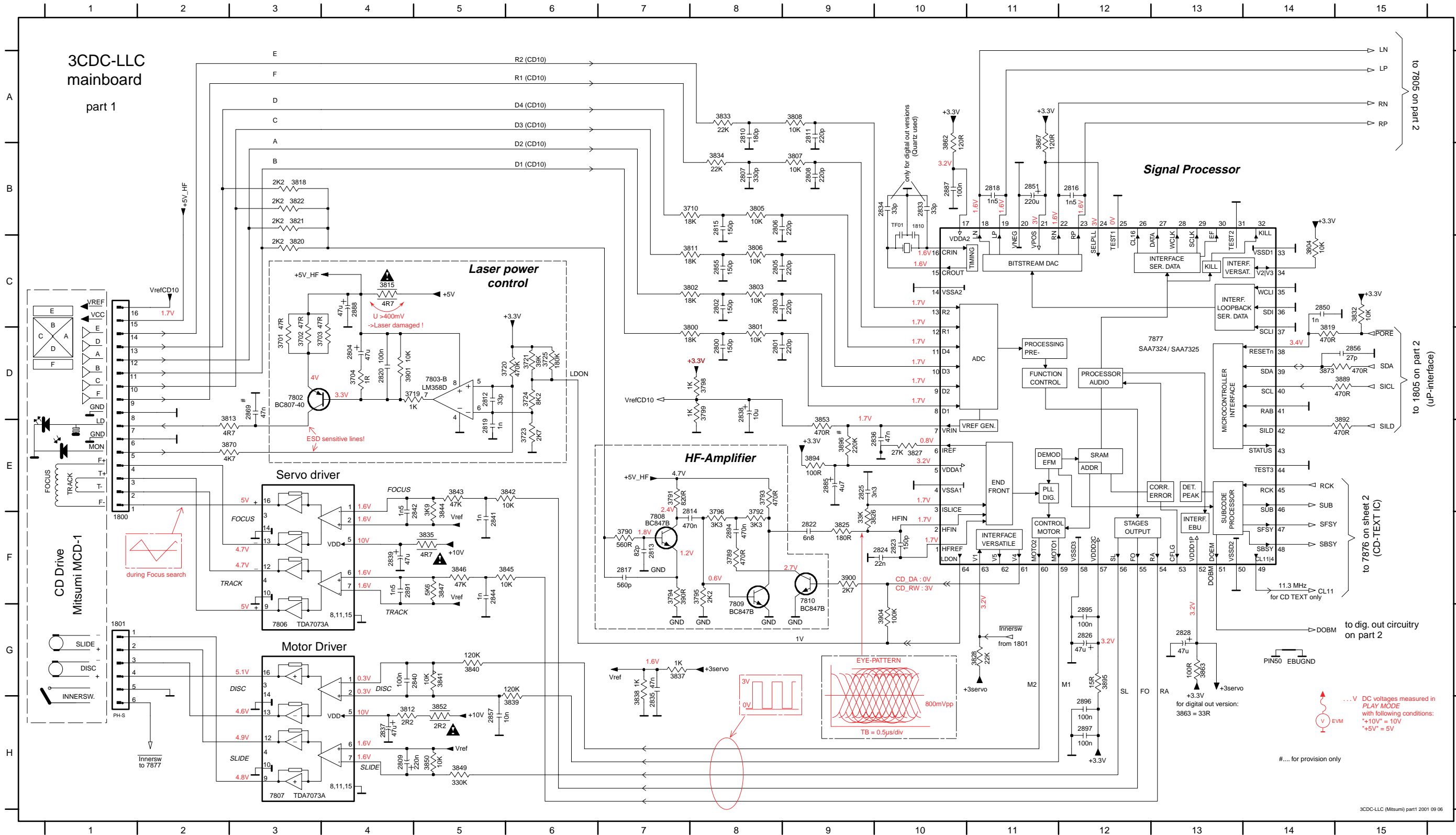

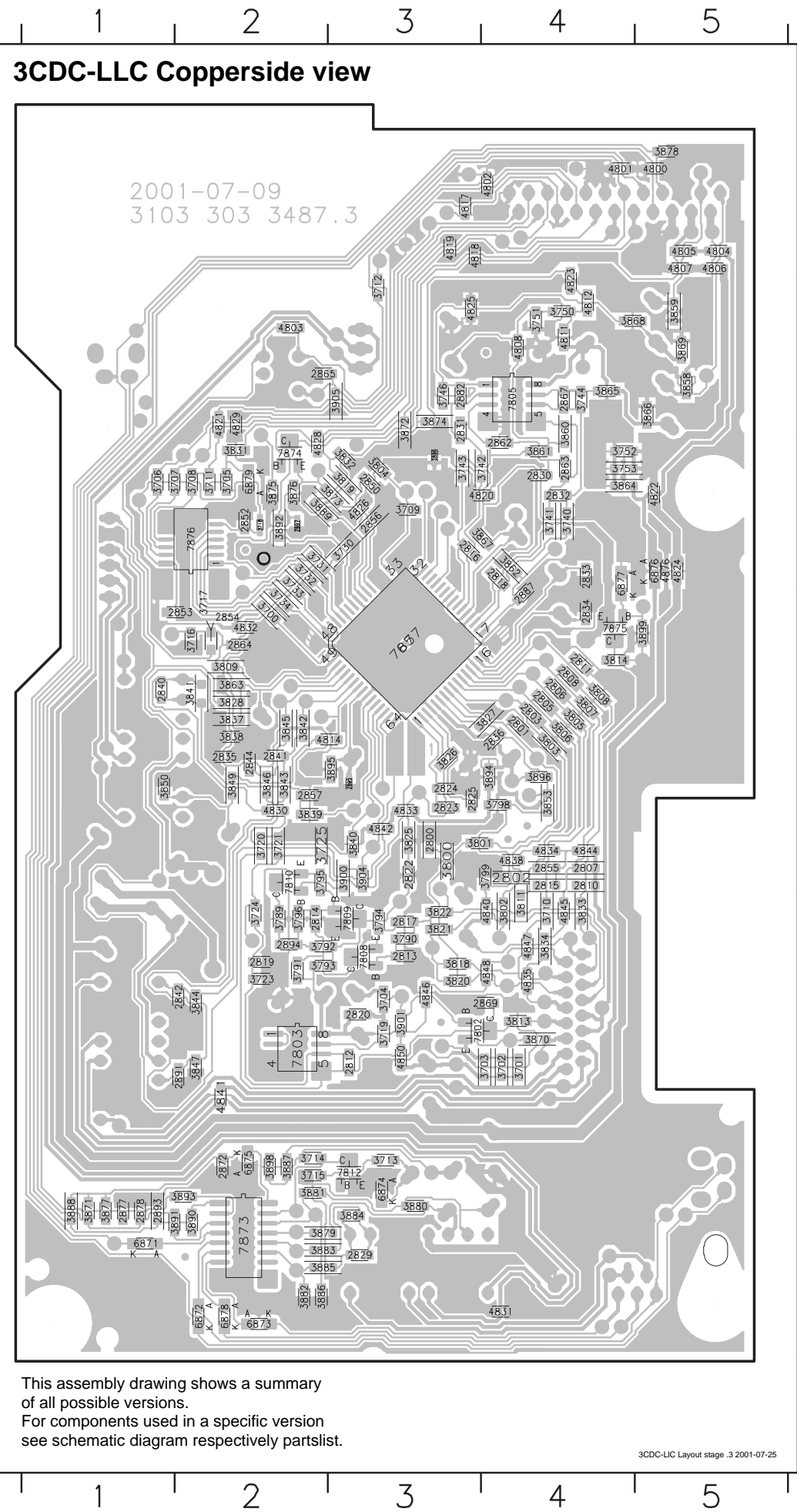

This assembly drawing shows a summary of all possible versions. For components used in a specific version see schematic diagram respectively partlist.

Mapping

Copperside		Componentside	
2800 E3	3741 C4	3889 C2	1800 F2
2801 D4	3742 C4	3890 H2	1801 C5
2802 E4	3743 C3	3891 H2	1805 A2
2803 D4	3744 B4	3892 C2	1810 C2
2805 D4	3746 B3	3893 G2	1875 H1
2806 D4	3750 B4	3894 E4	1878 B3
2807 E4	3751 B4	3895 E3	1880 B5
2808 D4	3752 C4	3896 E4	1881 G1
2810 E4	3753 C4	3898 G2	2804 F3
2811 D4	3789 F2	3899 D5	2809 E4
2812 G3	3790 F3	3900 E3	2826 D3
2813 F3	3791 F2	3901 F3	2828 D4
2814 F2	3792 F3	3904 E3	2837 E5
2815 E4	3793 F3	3905 B3	2838 F2
2816 C3	3794 F3	4800 A5	2839 E5
2817 F3	3795 E2	4801 A4	2851 C2
2818 C4	3796 F2	4802 A4	2858 B2
2819 F2	3798 E4	4803 B2	2860 B1
2820 F3	3799 E4	4804 A5	2861 B1
2822 E3	3800 E3	4805 A5	2873 H2
2823 E3	3801 E4	4806 A5	2875 G3
2824 E3	3802 F4	4807 A5	2876 B2
2825 E3	3803 D4	4808 B4	2881 G3
2829 H3	3804 C3	4811 B4	2885 D2
2830 C4	3805 D4	4812 B4	2888 F4
2831 B3	3806 D4	4814 D3	3812 F4
2832 C4	3807 D4	4817 A3	3815 G3
2833 C4	3808 D4	4818 A3	3835 F5
2834 D4	3809 D2	4819 A3	3851 G2
2835 E2	3811 F4	4820 C4	3852 E5
2836 D4	3813 F4	4821 B2	5802 B4
2840 D1	3814 D4	4822 C5	7806 F5
2841 E2	3818 F3	4823 A4	7807 D5
2842 F2	3819 C3	4824 C5	7871 H3
2844 E2	3820 F3	4825 B3	
2850 C3	3821 F3	4826 C3	
2852 C2	3822 F3	4828 C2	
2853 D2	3825 E3	4829 B2	
2854 D2	3826 E3	4830 E2	
2855 E4	3827 D4	4831 H4	
2856 C3	3828 D2	4832 D2	
2857 E2	3831 C2	4833 E3	
2862 C4	3832 C3	4834 E4	
2863 C4	3833 F4	4835 F4	
2864 D2	3834 F4	4838 E4	
2865 B3	3837 D2	4840 F4	
2867 B4	3838 D2	4841 G2	
2869 F4	3839 E2	4842 E3	
2872 G2	3840 E3	4844 E4	
2877 H1	3841 D2	4845 F4	
2878 H1	3842 D2	4846 F3	
2882 B3	3843 E2	4847 F4	
2887 C4	3844 F2	4848 F4	
2891 G2	3845 D2	4850 G3	
2893 H1	3846 E2	4876 C5	
2894 F2	3847 G2	6871 H1	
2895 E3	3849 E2	6872 H2	
2896 C3	3850 E1	6873 H2	
2897 C2	3853 E4	6874 G3	
3700 D2	3858 B5	6875 G2	
3701 G4	3859 B5	6876 C5	
3702 G4	3860 B4	6877 C4	
3703 G4	3861 C4	6878 H2	
3704 F3	3862 C4	6879 C2	
3705 C2	3863 D2	7802 F4	
3706 C1	3864 C4	7803 F2	
3707 C2	3865 B4	7805 B4	
3708 C2	3866 B5	7808 F3	
3709 C3	3867 C4	7809 F3	
3710 F4	3868 B5	7810 E2	
3711 C2	3869 B5	7812 G3	
3712 A3	3870 F4	7873 H2	
3713 G3	3871 H1	7874 C2	
3714 G2	3872 B3	7875 D4	
3715 G2	3873 C3	7876 C2	
3716 D2	3874 B3	7877 D3	
3717 D2	3875 C2		
3718 C2	3876 C2		
3719 F3	3877 H1		
3720 E2	3878 A5		
3721 E2	3879 H3		
3723 F2	3880 G3		
3724 F2	3881 G2		
3725 E2	3882 H2		
3730 C3	3883 H3		
3731 C2	3884 H3		
3732 C2	3885 H3		
3733 C2	3886 H2		
3734 D2	3887 G2		
3740 C4	3888 H1		

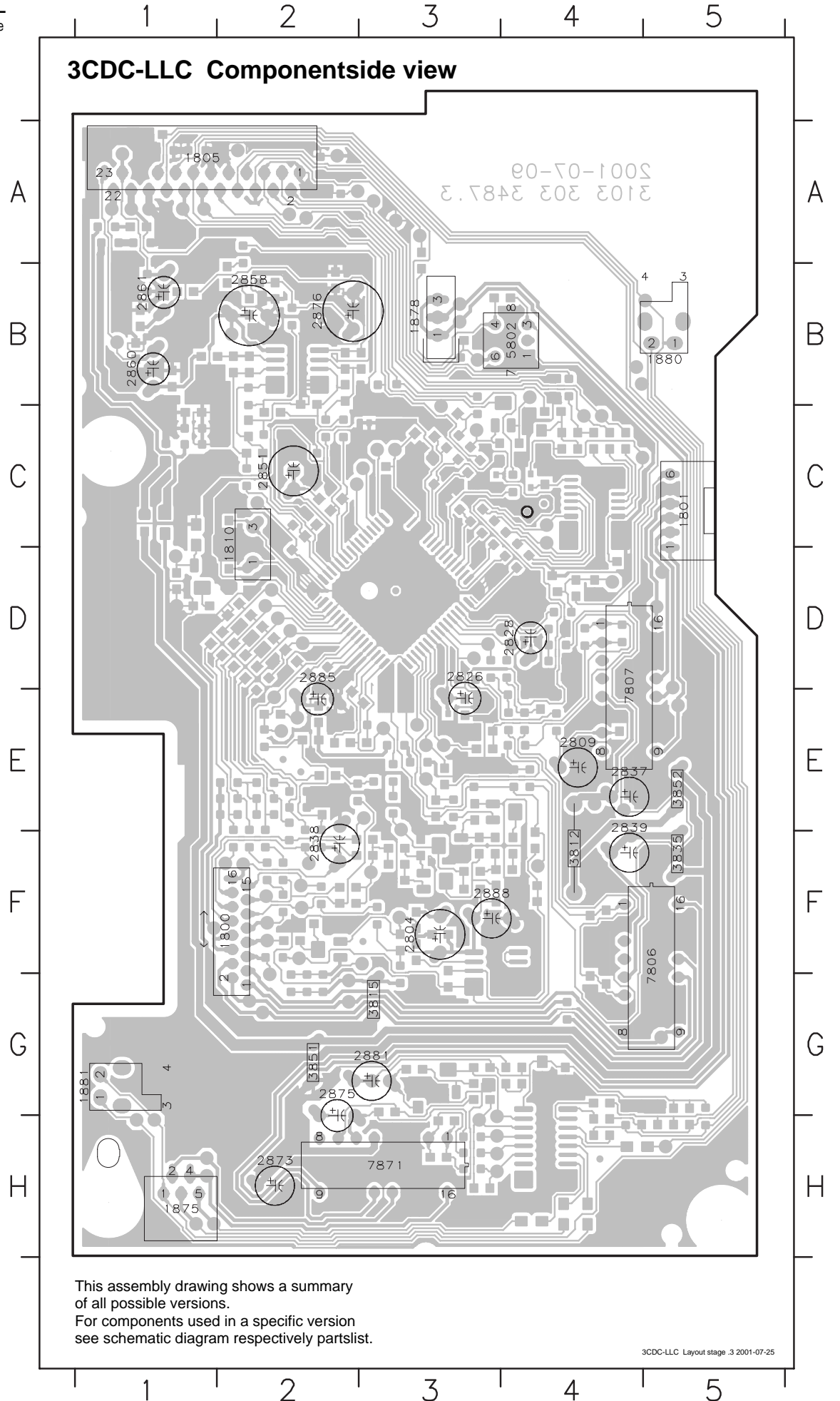

This assembly drawing shows a summary of all possible versions. For components used in a specific version see schematic diagram respectively partlist.

1805 E15	2830 C9	2858 A9	2865 C4	2877 F11	3705 G4	3713 G8	3730 G2	3741 A7	3751 C7	3851 D7	3865 A10	3874 C13	3880 E6	3886 E7	3898 F7	4876 D13	6875 F7	7805-B A8	7876 G3	MP726 D8	MP804 G14	MP811 F14	MP832 G9	MP863 C11	MP871 D6	MP888 G5	MP898 E13	
1875 D2	2831 B9	2860 A11	2867 A8	2878 F11	3706 G4	3714 F8	3731 G2	3742 B7	3752 A6	3858 A11	3866 A10	3875 C12	3881 E7	3887 D6	3899 D12	5802 B4	6876 D13	7812 G8	7812 G8	MP721 C8	MP740 H14	MP805 F13	MP822 E3	MP865 D11	MP874 D12	MP889 G5	MP899 E14	
1878 E2	2832 A8	2861 B11	2872 G10	2881 F8	3707 G4	3715 G8	3732 G2	3743 B7	3753 A6	3859 B11	3868 B10	3876 C11	3882 D7	3888 F12	3905 C5	6871 F8	6877 D12	7871 C5	7871 C5	MP722 E8	MP742 G14	MP806 F13	MP823 E3	MP835 F14	MP866 E8	MP881 G2	MP890 B3	
1880 F8	2852 H2	2862 B8	2873 D6	2882 B10	3708 H4	3716 B3	3733 G2	3744 A9	3809 B2	3860 B7	3869 B10	3877 F12	3883 D6	3890 F11	4803 B4	6872 E8	6878 E8	6878 E8	7873 D10	7873 D8	MP723 D8	MP742 G14	MP807 F14	MP824 D4	MP854 A13	MP867 E8	MP882 G2	MP891 B5
1881 E8	2853 G4	2863 B8	2875 E6	2883 F12	3711 G5	3717 B3	3734 H2	3746 B10	3814 D12	3861 B8	3871 F12	3878 E12	3884 D6	3891 F11	4811 A7	6873 E8	6879 G4	7874 C12	7874 C12	MP724 D8	MP801 E12	MP808 F13	MP825 D4	MP856 E14	MP868 F8	MP886 G3	MP892 B5	
2829 D6	2854 B3	2864 B3	2876 C7	3700 H2	3712 B4	3718 G3	3740 A7	3750 B7	3831 G4	3864 A7	3872 C13	3879 D7	3885 D6	3893 F11	4812 B7	6874 G7	7805-A B9	7875 D12	7875 D12	MP725 D8	MP803 F10	MP810 F13	MP830 A7	MP857 B13	MP869 C12	MP887 H5	MP897 E13	

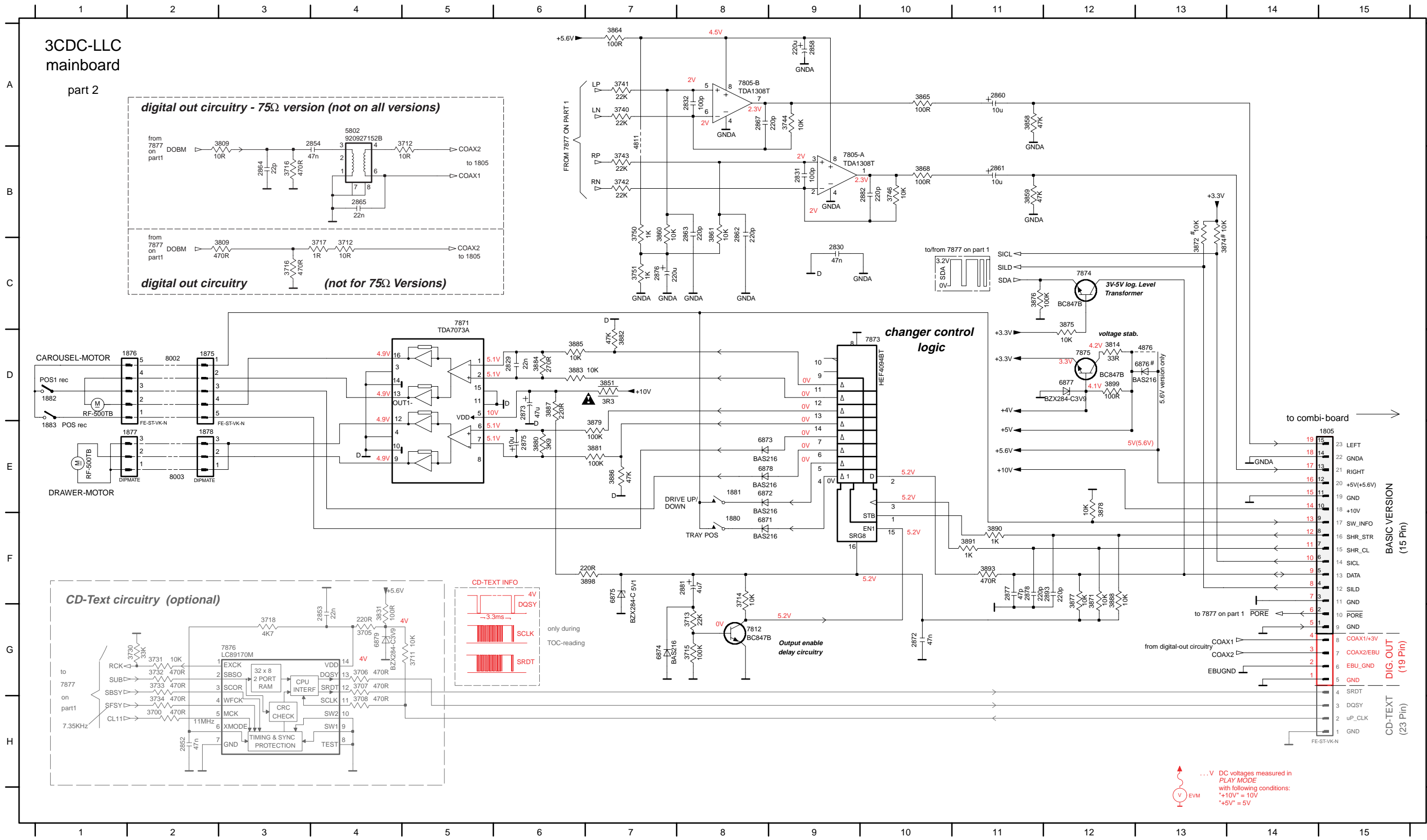

EXPLODED VIEW (3CDC-LC MODULE)

MECHANICAL PARTS Loader → this page

20	3103 304 66500	DRAWER
21	3140 114 29070	PRESSURE RING-MCD1
23	3140 111 21270	METAL RING-MCD1
30	3103 304 66560	SUPPORT
31	4822 529 10386	RUBBER DAMPER CD DRIVE, REAR
32	4822 529 10387	RUBBER DAMPER CD DRIVE, FRONT
33	3103 304 06970	WASHER
35	3103 309 05350	CD DRIVE MCD1B
41	3103 304 66480	FRAME
42	3103 304 66540	BRACKET-GUIDING
43	3103 301 06460	SPRING-GUIDING
44	3103 304 06890	GEAR-3
45	3103 304 06980	NAIL FIXATION
46	3103 304 06880	GEAR-2
47	3103 304 66530	BRACKET-LOAD
48	3103 304 06910	CAM
49	3103 304 66510	GUIDING
51	3103 304 06900	GEAR-4
52	3103 304 06870	GEAR-1
53	3103 304 06960	PULLEY-FRAME
54	3103 304 66910	DRIVING-BELT-DRAWER
55	4822 361 10753	TRAY MOTOR
56	4822 502 12548	SCREW M2,6X3,5
57	3103 304 69880	COVER-MCD1
59	4822 466 12146	RUBBER

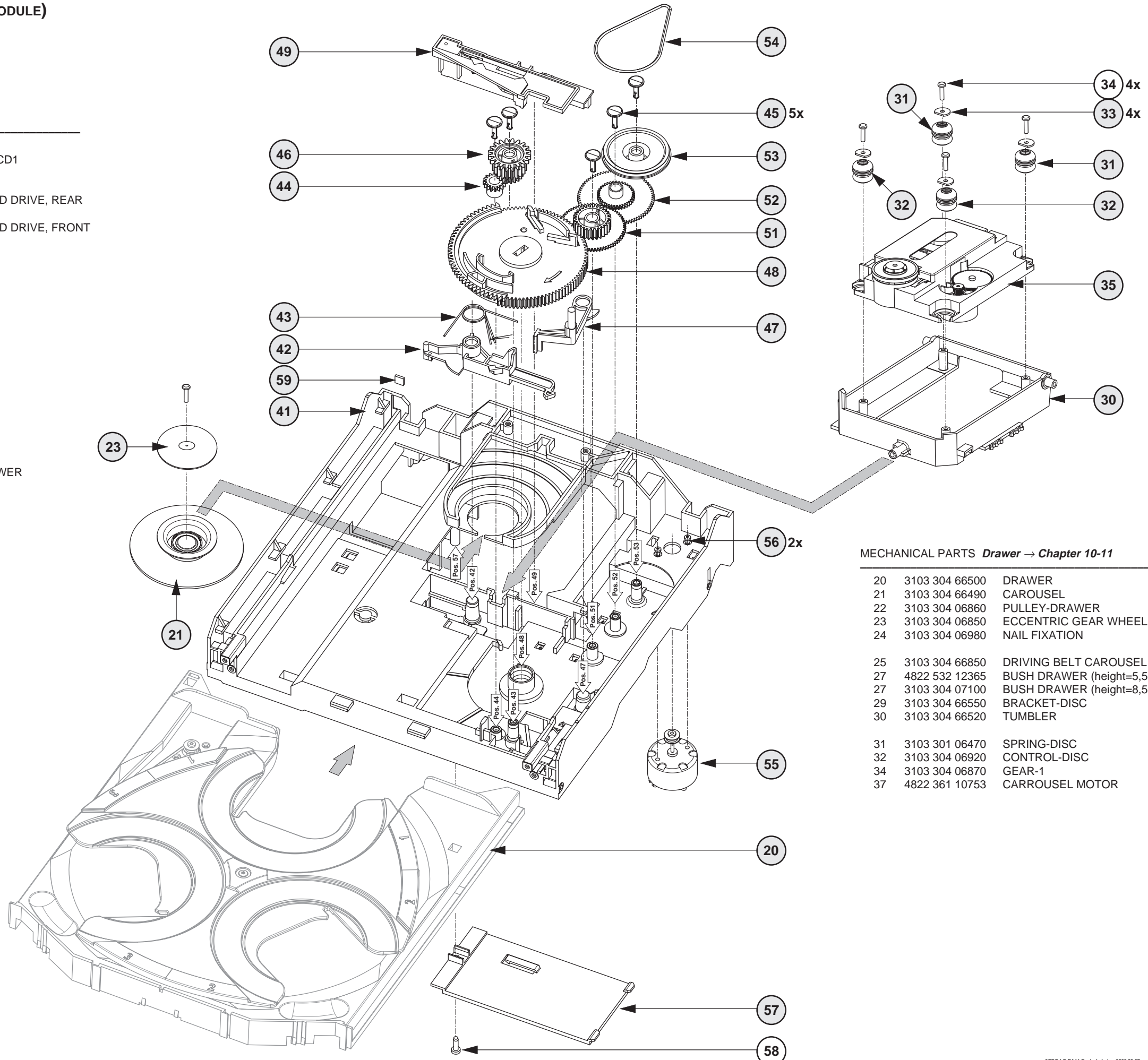

MECHANICAL PARTS Drawer → Chapter 10-11

20	3103 304 66500	DRAWER
21	3103 304 66490	CAROUSEL
22	3103 304 06860	PULLEY-DRAWER
23	3103 304 06850	ECCENTRIC GEAR WHEEL
24	3103 304 06980	NAIL FIXATION
25	3103 304 66850	DRIVING BELT CAROUSEL
27	4822 532 12365	BUSH DRAWER (height=5,5mm,d=9,4mm)
27	3103 304 07100	BUSH DRAWER (height=8,5mm,d=16mm)
29	3103 304 66550	BRACKET-DISC
30	3103 304 66520	TUMBLER
31	3103 301 06470	SPRING-DISC
32	3103 304 06920	CONTROL-DISC
34	3103 304 06870	GEAR-1
37	4822 361 10753	CARROUSEL MOTOR

- X** spare part
- Y** non spare part

Drawer bottom view

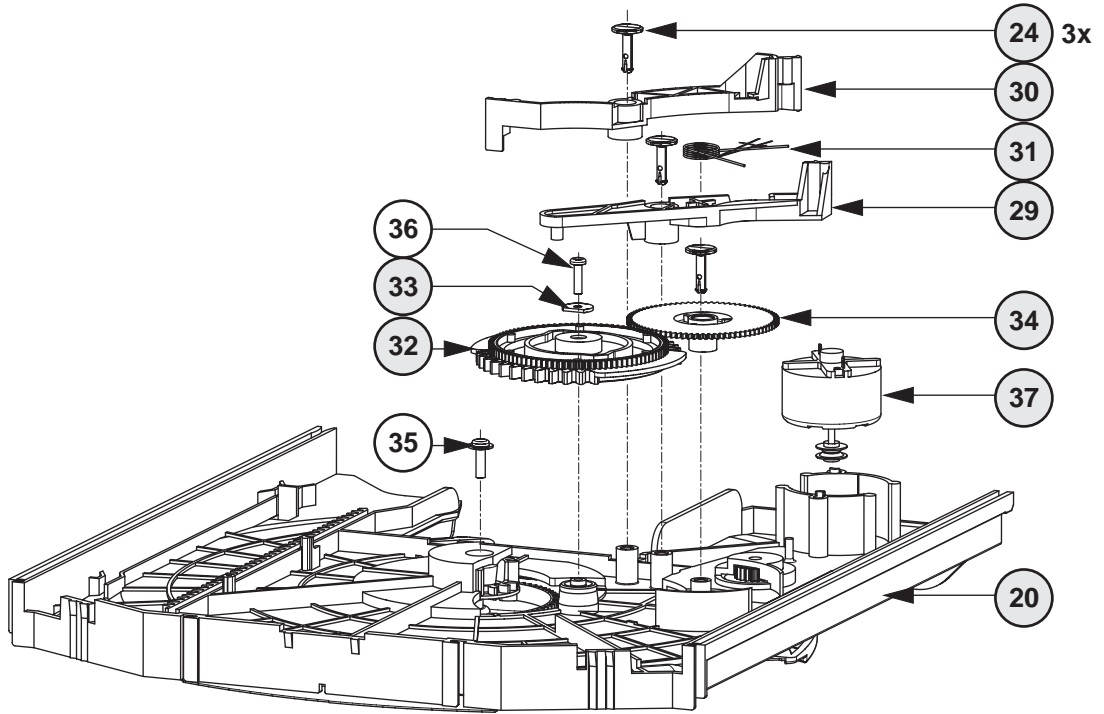

Drawer top view

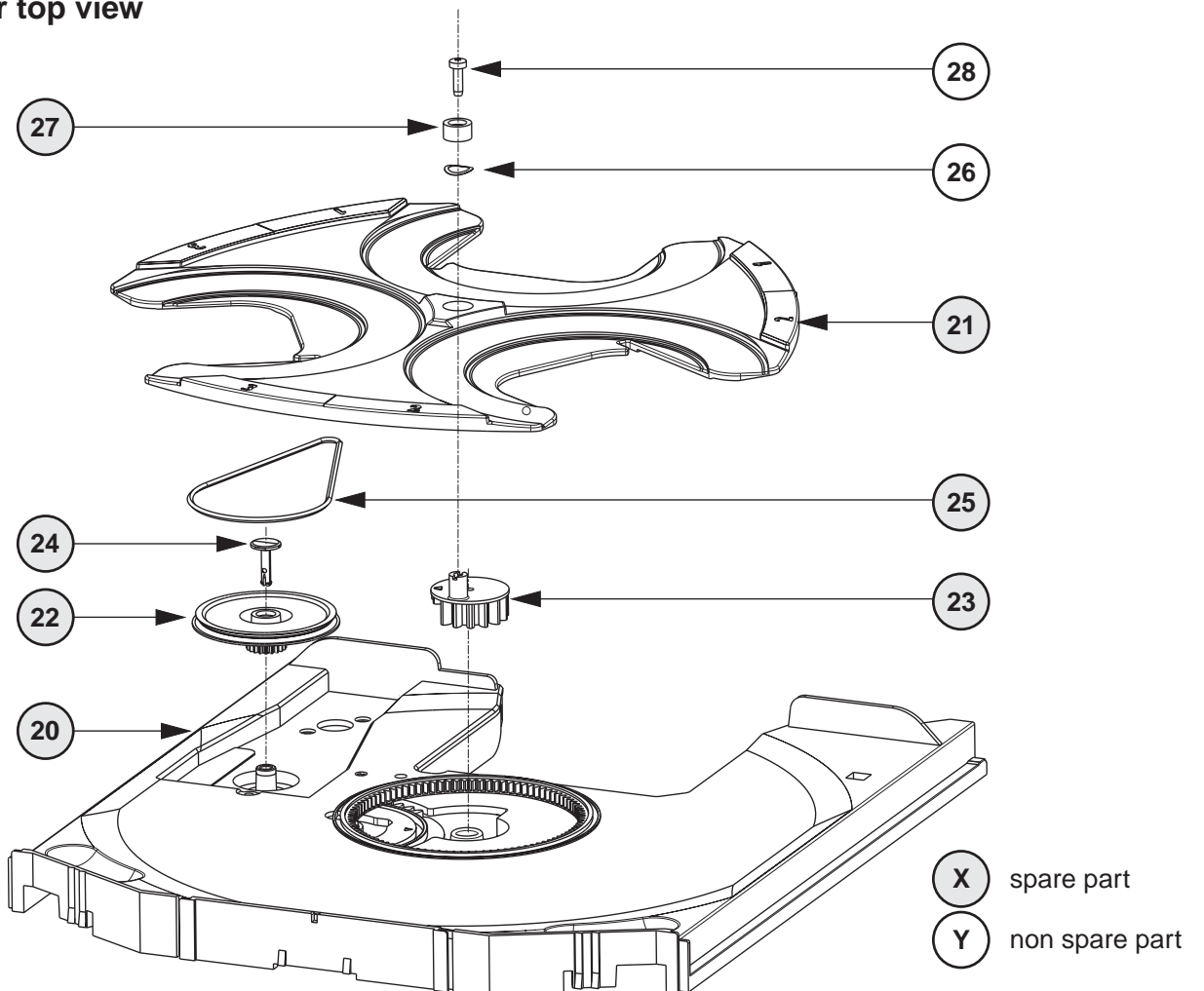

ELECTRICAL PARTSLIST 3CDC-LLC-MCD1 MODULE**MISCELLANEOUS**

35	3103 309 05350	CD DRIVE MCD1B
37	4822 361 10753	CAROUSEL MOTOR
55	4822 361 10753	TRAY MOTOR
1800	2422 025 17389	FLEX FOIL CONNECTOR 16Pin
1805	4822 265 10979	FLEX FOIL CONNECTOR 15Pin
1805	4822 265 11545	FLEX FOIL CONNECTOR 19Pin
1875	4822 267 10958	FLEX FOIL CONNECTOR 5Pin
1876	2422 025 08332	FLEX FOIL CONNECTOR 5Pin
1880	4822 276 13503	SWITCH, Tray switch
1881	4822 276 13503	SWITCH, Drive UP/DOWN
1882	4822 276 13503	SWITCH, CD Pos.1 recognized
1883	4822 276 13503	SWITCH, valid CD Play position
8002	3103 308 91990	FLEX FOIL CABLE 5P, 200mm 1:n
8005	3103 308 92930	FLEX FOIL CABLE 16P 170mm 1:n

CAPACITORS

2800	4822 122 33172	390pF	5%	50V
2801	4822 126 13883	220pF	5%	50V
2802	4822 122 33172	390pF	5%	50V
2803	4822 126 13883	220pF	5%	50V
2804	4822 124 41751	47μF	20%	16V
2805	4822 126 13883	220pF	5%	50V
2806	4822 126 13883	220pF	5%	50V
2807	5322 122 31863	330pF	5%	50V
2808	4822 126 13883	220pF	5%	50V
2809	4822 124 40746	0,22μF	20%	63V
2810	4822 126 10326	180pF	5%	
2811	4822 126 13883	220pF	5%	50V
2812	2222 867 15339	33pF	5%	50V
2813	4822 126 14226	82pF		50V
2814	2238 246 59858	450nF	20%	10V
2815	4822 122 33172	390pF	5%	50V
2816	4822 126 14247	1,5nF	10%	50V
2817	4822 126 14249	560pF	10%	50V
2818	4822 126 13344	1,5nF	5%	63V
2819	5322 126 11578	1nF	10%	63V
2820	4822 126 14305	100nF	10%	16V
2822	5322 122 31866	6,8nF	10%	63V
2823	3198 016 31510	150pF	10%	50V
2824	5322 122 32654	22nF	10%	63V
2825	4822 122 33891	3,3nF	10%	63V
2826	4822 124 12362	47μF	20%	4V
2828	4822 124 12362	47μF	20%	4V
2829	3198 017 42230	22nF	10%	50V
2830	4822 126 13751	47nF	10%	50V
2831	4822 122 31765	100pF	5%	50V
2832	4822 122 31765	100pF	5%	50V
2835	3198 024 44730	47nF	5%	50V
2836	3198 024 44730	47nF	5%	50V
2837	4822 124 40433	47μF	20%	25V
2838	4822 124 40248	10μF	20%	63V
2839	4822 124 40433	47μF	20%	25V
2840	4822 126 14585	100nF	10%	50V
2841	5322 126 10511	1nF	5%	50V
2842	4822 126 14247	1,5nF	10%	50V
2844	3198 016 31020	1nF	5%	25V
2850	5322 126 11578	1nF	10%	63V
2851	4822 124 42383	220μF	20%	4V
2855	4822 122 33172	390pF	5%	50V
2856	4822 126 13691	27pF	1%	63V
2857	5322 126 11583	10nF	10%	63V
2858	4822 124 12245	220μF	20%	16V

CAPACITORS

2860	4822 124 11947	10μF	20%	16V
2861	4822 124 11947	10μF	20%	16V
2862	4822 126 13883	220pF	5%	50V
2863	4822 126 13883	220pF	5%	50V
2865	4822 126 14494	22nF	10%	25V
2867	4822 126 13883	220pF	5%	50V
2872	3198 024 44730	47nF	5%	50V
2873	4822 124 80231	47μF	20%	16V
2875	4822 124 11947	10μF	20%	16V
2876	4822 124 12245	220μF	20%	16V
2877	4822 122 33777	47pF	5%	63V
2878	4822 126 13883	220pF	5%	50V
2881	4822 124 40769	4,7μF	20%	100V
2882	4822 126 13883	220pF	5%	50V
2885	4822 124 40769	4,7μF	20%	100V
2887	4822 126 14585	100nF	10%	50V
2888	4822 124 80231	47μF	20%	16V
2891	4822 126 14247	1,5nF	10%	50V
2893	4822 122 33575	220pF	5%	50V
2894	3198 017 44740	470nF	20%	10V
2895	4822 126 14305	100nF	10%	16V
2896	4822 126 14305	100nF	10%	16V
2897	4822 126 14305	100nF	10%	16V

RESISTORS

3701	4822 051 20479	47Ω	5%	0,1W
3702	4822 051 20479	47Ω	5%	0,1W
3703	4822 051 20479	47Ω	5%	0,1W
3704	4822 117 12917	1Ω	5%	0,06W
3710	4822 051 51831	18kΩ	5%	0,1W
3712	4822 051 30109	10Ω	5%	0,06W
3713	4822 051 30223	22kΩ	5%	0,06W
3714	4822 051 30103	10kΩ	5%	0,06W
3715	4822 117 13632	100kΩ	1%	0,06W
3716	4822 051 30471	470Ω	5%	0,06W
3717	4822 117 12917	1Ω	5%	0,06W
3719	4822 051 30102	1kΩ	5%	0,06W
3720	4822 051 20474	470kΩ	5%	0,1W
3721	4822 051 20393	39kΩ	5%	0,1W
3723	4822 051 30272	2,7kΩ	5%	0,06W
3724	4822 117 12902	8,2kΩ	1%	0,06W
3725	4822 051 30184	180kΩ	5%	0,06W
3730	4822 051 20333	33kΩ	5%	0,1W
3740	4822 051 20223	22kΩ	5%	0,1W
3741	4822 051 20223	22kΩ	5%	0,1W
3742	4822 051 20223	22kΩ	5%	0,1W
3743	4822 051 20223	22kΩ	5%	0,1W
3744	4822 051 30103	10kΩ	5%	0,06W
3746	4822 051 30103	10kΩ	5%	0,06W
3750	4822 051 30102	1kΩ	5%	0,06W
3751	4822 051 30102	1kΩ	5%	0,06W
3789	4822 051 30471	470Ω	5%	0,06W
3790	4822 051 30561	560Ω	5%	0,06W
3791	4822 117 12968	820Ω	5%	0,06W
3792	4822 051 30332	3,3kΩ	5%	0,06W
3793	4822 051 20471	470Ω	5%	0,1W
3794	4822 051 30391	390Ω	5%	0,06W
3795	4822 051 30222	2,2kΩ	5%	0,06W
3796	4822 051 30332	3,3kΩ	5%	0,06W
3798	4822 051 30102	1kΩ	5%	0,06W
3799	4822 051 30102	1kΩ	5%	0,06W
3800	4822 051 51831	18kΩ	5%	0,1W

ELECTRICAL PARTSLIST 3CDC-LLC-MCD1 MODULE

RESISTORS

3801	© 4822 051 30103	10kΩ	5%	0,06W
3802	© 4822 051 51831	18kΩ	5%	0,1W
3803	© 4822 117 10833	10kΩ	1%	0,1W
3804	© 4822 051 30103	10kΩ	5%	0,06W
3805	© 4822 051 30103	10kΩ	5%	0,06W
3806	© 4822 051 30103	10kΩ	5%	0,06W
3807	© 4822 051 30103	10kΩ	5%	0,06W
3808	© 4822 051 30103	10kΩ	5%	0,06W
3809	© 4822 051 20471	470Ω	5%	0,1W
3811	© 4822 051 51831	18kΩ	5%	0,1W
3812	4822 053 10228	2,2Ω	5%	1W
3813	© 4822 117 13608	4,7Ω	5%	0,06W
3814	© 4822 051 30339	33Ω	5%	0,06W
3815	4822 052 10478	4,7Ω	5%	NFR
3818	© 4822 051 30222	2,2kΩ	5%	0,06W
3819	© 4822 051 20471	470Ω	5%	0,1W
3820	© 4822 051 30222	2,2kΩ	5%	0,06W
3821	© 4822 051 30222	2,2kΩ	5%	0,06W
3822	© 4822 051 30222	2,2kΩ	5%	0,06W
3825	© 4822 051 20181	180Ω	5%	0,1W
3826	© 4822 051 30333	33kΩ	5%	0,06W
3827	© 4822 051 20273	27kΩ	5%	0,1W
3828	© 4822 051 20223	22kΩ	5%	0,1W
3831	© 4822 051 30101	100Ω	5%	0,06W
3832	© 4822 051 30103	10kΩ	5%	0,06W
3833	© 4822 051 30223	22kΩ	5%	0,06W
3834	© 4822 051 20223	22kΩ	5%	0,1W
3835	4822 052 10478	4,7Ω	5%	NFR
3837	© 4822 051 10102	1kΩ	2%	0,25W
3838	© 4822 051 30102	1kΩ	5%	0,06W
3839	© 4822 051 20124	120kΩ	5%	0,1W
3840	© 4822 051 30124	120kΩ	5%	0,06W
3841	© 4822 117 10833	10kΩ	1%	0,1W
3842	© 4822 117 10833	10kΩ	1%	0,1W
3843	© 4822 117 10834	47kΩ	1%	0,1W
3844	© 4822 051 20392	3,9kΩ	5%	0,1W
3845	© 4822 117 10833	10kΩ	1%	0,1W
3846	© 4822 117 10834	47kΩ	1%	0,1W
3847	© 4822 051 20562	5,6kΩ	5%	0,1W
3849	© 4822 051 20334	330kΩ	5%	0,1W
3850	© 4822 051 30103	10kΩ	5%	0,06W
3851	4822 052 10338	3,3Ω		NFR25
3852	4822 052 10228	2,2Ω	5%	0,33W
3853	© 4822 051 20471	470Ω	5%	0,1W
3858	© 4822 117 12925	47kΩ	1%	0,06W
3859	© 4822 117 10834	47kΩ	1%	0,1W
3860	© 4822 117 10833	10kΩ	1%	0,1W
3861	© 4822 051 30103	10kΩ	5%	0,06W
3862	© 4822 051 20121	120Ω	5%	0,1W
3863	© 4822 117 11373	100Ω	1%	0,1W
3864	© 4822 117 11373	100Ω	1%	0,1W
3865	© 4822 051 30101	100Ω	5%	0,06W
3867	© 4822 051 30121	120Ω	5%	0,06W
3868	© 4822 051 30101	100Ω	5%	0,06W
3870	© 4822 051 20472	4,7kΩ	5%	0,1W
3871	© 4822 051 30103	10kΩ	5%	0,06W
3873	© 4822 051 20471	470Ω	5%	0,1W
3875	© 4822 051 30103	10kΩ	5%	0,06W
3876	© 4822 117 13632	100kΩ	1%	0,06W
3877	© 4822 051 30103	10kΩ	5%	0,06W
3878	© 4822 051 30103	10kΩ	5%	0,06W
3879	© 4822 117 10837	100kΩ	1%	0,1W

RESISTORS

3880	© 4822 051 30392	3,9kΩ	5%	0,06W
3881	© 4822 117 13632	100kΩ	1%	0,06W
3882	© 4822 117 12925	47kΩ	1%	0,06W
3883	© 4822 117 10833	10kΩ	1%	0,1W
3884	© 4822 051 30271	270Ω	5%	0,06W
3885	© 4822 117 10833	10kΩ	1%	0,1W
3886	© 4822 117 12925	47kΩ	1%	0,06W
3887	© 4822 051 30221	220Ω	5%	0,06W
3888	© 4822 117 10833	10kΩ	1%	0,1W
3889	© 4822 051 20471	470Ω	5%	0,1W
3890	© 4822 051 30102	1kΩ	5%	0,06W
3891	© 4822 051 30102	1kΩ	5%	0,06W
3892	© 4822 051 20471	470Ω	5%	0,1W
3893	© 4822 051 30471	470Ω	5%	0,06W
3894	© 4822 051 30101	100Ω	5%	0,06W
3895	© 4822 117 12971	15Ω	5%	0,06W
3898	© 4822 051 30221	220Ω	5%	0,06W
3899	© 4822 051 30101	100Ω	5%	0,06W
3900	© 4822 117 12955	2,7kΩ	1%	0,1W
3901	© 4822 117 10833	10kΩ	1%	0,1W
3904	© 4822 117 13632	100kΩ	1%	0,06W
4800	© 4822 051 20008			CHIP JUMPER 0805
4801	© 4822 051 20008			CHIP JUMPER 0805
4802	© 4822 051 20008			CHIP JUMPER 0805
4803	© 4822 051 30008			CHIP JUMPER 0603
4804	© 4822 051 20008			CHIP JUMPER 0805
4805	© 4822 051 30008			CHIP JUMPER 0603
4806	© 4822 051 20008			CHIP JUMPER 0805
4807	© 4822 051 20008			CHIP JUMPER 0805
4808	© 4822 051 20008			CHIP JUMPER 0805
4811	© 4822 051 20008			CHIP JUMPER 0805
4814	© 4822 051 20008			CHIP JUMPER 0805
4817	© 4822 051 20008			CHIP JUMPER 0805
4818	© 4822 051 20008			CHIP JUMPER 0805
4819	© 4822 051 20008			CHIP JUMPER 0805
4820	© 4822 051 20008			CHIP JUMPER 0805
4821	© 4822 051 20008			CHIP JUMPER 0805
4822	© 4822 051 20008			CHIP JUMPER 0805
4823	© 4822 051 20008			CHIP JUMPER 0805
4824	© 4822 051 30008			CHIP JUMPER 0603
4825	© 4822 051 30008			CHIP JUMPER 0603
4826	© 4822 051 20008			CHIP JUMPER 0805
4828	© 4822 051 20008			CHIP JUMPER 0805
4829	© 4822 051 20008			CHIP JUMPER 0805
4830	© 4822 051 20008			CHIP JUMPER 0805
4831	© 4822 051 20008			CHIP JUMPER 0805
4832	© 4822 051 30008			CHIP JUMPER 0603
4833	© 4822 051 20008			CHIP JUMPER 0805
4834	© 4822 051 20008			CHIP JUMPER 0805
4835	© 4822 051 20008			CHIP JUMPER 0805
4838	© 4822 051 30008			CHIP JUMPER 0603
4840	© 4822 051 20008			CHIP JUMPER 0805
4841	© 4822 051 30008			CHIP JUMPER 0603
4842	© 4822 051 20008			CHIP JUMPER 0805
4844	© 4822 051 20008			CHIP JUMPER 0805
4845	© 4822 051 20008			CHIP JUMPER 0805
4846	© 4822 051 20008			CHIP JUMPER 0805
4847	© 4822 051 20008			CHIP JUMPER 0805
4848	© 4822 051 20008			CHIP JUMPER 0805
4850	© 4822 051 20008			CHIP JUMPER 0805
4876	© 4822 051 20008			CHIP JUMPER 0805

ELECTRICAL PARTSLIST 3CDC-LLC-MCD1 MODULE**COILS**

 1810 4822 242 73557 CERAMIC RES. 8,46MHz
DIODES

 6871 © 4822 130 11397 BAS316
 6872 © 4822 130 11397 BAS316
 6873 © 4822 130 11397 BAS316
 6874 © 4822 130 11397 BAS316
 6875 © 9340 548 52115 BZX284-C5V1

 6877 © 9322 129 34685 BZX284-C3V9
 6878 © 4822 130 11397 BAS316
 6879 © 9322 129 34685 BZX284-C3V9
TRANSISTORS

 7802 © 5322 130 60123 BC807-40
 7808 © 4822 130 60511 BC847B
 7809 © 4822 130 60511 BC847B
 7810 © 4822 130 60511 BC847B
 7812 © 4822 130 60511 BC847B

 7874 © 4822 130 60511 BC847B
 7875 © 4822 130 60511 BC847B
INTEGRATED CIRCUITS

 7803 © 5322 209 82941 LM358D, Dual Opamp
 7805 © 4822 209 33165 TDA1308T/N1
 7806 4822 209 32852 TDA7073A/N2
 7807 4822 209 32852 TDA7073A/N2
 7871 4822 209 32852 TDA7073A/N2

 7873 © 5322 209 11306 HEF4094BT, SHIFT REGISTER
 7877 © 9352 641 80557 SAA7324H/M2B,"CD10" SIGN.PROC.

COMBI BOARD

TABLE OF CONTENTS

Brief Introduction	11-1
Component Layout - Main part (excluding Tuner portion)	11-2
Chip Layout - Main part (excluding Tuner portion)	11-3
Power Supply Circuit	11-4
Source Selection Circuit	11-5
Pre- and Power Amplifier Circuit	11-6
Circuit & Component diagrams - Trafo Pr. and Sec. parts	11-7
Non-Cenelec Tuner portions & Adjustment Table	11-8
Non-Cenelec Tuner Circuit	11-9
Electrical parts list	11-10

Brief introduction of the Combi Board

A. TRANSFORMER PRIMARY PART

Transformer Primary Circuit provide connection for AC mains supply and primary wires of transformer.

B. POWER SUPPLY PART

Power Supply Circuit consists of rectifiers, capacitive filters and voltage regulators. Regulated voltage include +5V6, +LED, +12A, +12M, -32V, PWDN. The +C supply to the power amplifier is not regulated. F1-F2 is the ac supply voltage to the FTD Display filament.

C. SOURCE SELECT & AMPLIFIER PART

a) SHIFT REGISTER (AF CONTROL)

This shift register deliver commands from the μ P to control the AF functions which include source selection (A0 & A1 control lines), DSC modes , DBB, IS and CD_STBY. Other control lines such as MUTE, AMPON, STBY and PWM are coming directly from the μ P on the Front board.

b) SOURCE SELECTION

One of the 4 sources, namely AUX, TAPE, TUNER, CD, can be selected via A0 & A1 lines which control the IC 7501 (HEF4052BT). Karaoke mic. mixing is connected to th e selected source before the signal is amplified with a buffer amplifier (Tr 7503 & 7504). The source signal is then split into recording path (for recording on tape) and main signal path (to the PWM volume control).

c) PWM VOLUME CONTROL

The discrete volume control makes use of 4 Transistors 7505, 7506, 7507 & 7508 (ON4986 or selected BC557B) and PWM control signal from μ P. For good performance transistors for the left and right channels should be paired for gain characteristics.

d) SOUND FEATURES

Sound Features include the DBB, IS and 4 DSC modes. The sound features are realised with a hex-inverter IC 7530 (HEF4069UBT) as analog buffer/amplifier and transistors as electronic switches controlled by the shift registers (AF control).

e) POWER AMPLIFIER

IC 7391 (AN7125) is used as power amplifier.

f) CD_STBY CONTROL

This Transistor 7401 (BC337-25) switches on the supply +CD supply (derived from +12A) to CD servo control, HF circuit and the laser light pen on the CD Module during the CD mode only.

g) MATRIX SURROUND OUTPUT

The matrix surround feature is provided on board. This feature is only optional on certain type version.

D. KARAOKE PART

This simple Karaoke consists of a 1-mic. mono amplifier using discrete components. It has a level control using a rotary potmeter. This feature is available for some version only.

E. HEADPHONE PART

The headphone output is derived from the power amplifier output after the attenuation resistors which are tailored to deliver 18mW output power into a 32 ohm headphone.

F. CDC KEY PART

The CDC key buttons and LEDs are provided on this board.

SOURCE SELECTION CIRCUIT

C3 E15	C10 C14	1501 D1	1507 C13	2504 B4	2510 D4	2516 G8	2522 G7	2528 F7	2534 H10	2540 G11	2549 E15	2568 D15	2665 G5	3505 B3	3511 D3	3517 E2	3523 C6	3534 H9	3540 H11	3563 E12	3605 A8	6502 D6	7601 B8	9602 D15
C4 E15	C11 A3	1502 D2	1508 E14	2505 B4	2511 F2	2517 G6	2523 E7	2529 D9	2535 C10	2541 C11	2560 F12	2570 C1	2666 G8	3506 B3	3512 D3	3518 F2	3524 F7	3535 D9	3541 D11	3564 F12	3606 B8	6503 D12	7609 B9	9603 E15
C5 D15	C13 A3	1503 G1	1509 H1	2506 B4	2512 F2	2518 G7	2524 C6	2530 G9	2536 H10	2542 G11	2561 F12	2571 F1	3507 B3	3508 C3	3513 E3	3519 E3	3525 F7	3536 G9	3542 H11	3601 A7	3607 A8	6504 D13	9557 B15	TU_LEFT A3
C6 C15	C14 C15	1504 F1	2501 A4	2507 C4	2513 E4	2519 G6	2525 D6	2531 C9	2537 D10	2543 D15	2563 E12	2601 A8	3502 A3	3508 C3	3514 D3	3520 F3	3531 C8	3537 C9	3543 B2	3602 B7	4501 G5	6509 C1	9599 A3	TU_LEFT A3
C7 C15	T_E D14	1505 G2	2502 G4	2508 D4	2514 F3	2520 G7	2526 C7	2532 H9	2538 G10	2547 E12	2564 G12	2602 B7	3509 C3	3509 C3	3515 E3	3521 F3	3532 H8	3538 H9	3560 E12	3603 A9	5305 D15	7501 D8	9600 A3	T_E1 D14
C8 C15	1500 A1	1506 H1	2503 B4	2509 E4	2515 G6	2521 G6	2527 E7	2533 C10	2539 C11	2548 H2	2567 C8	2603 A8	3504 A4	3510 D3	3516 E4	3522 F3	3533 C9	3539 D11	3561 F12	3604 A8	5501 A2	7502 C7	9601 D15	

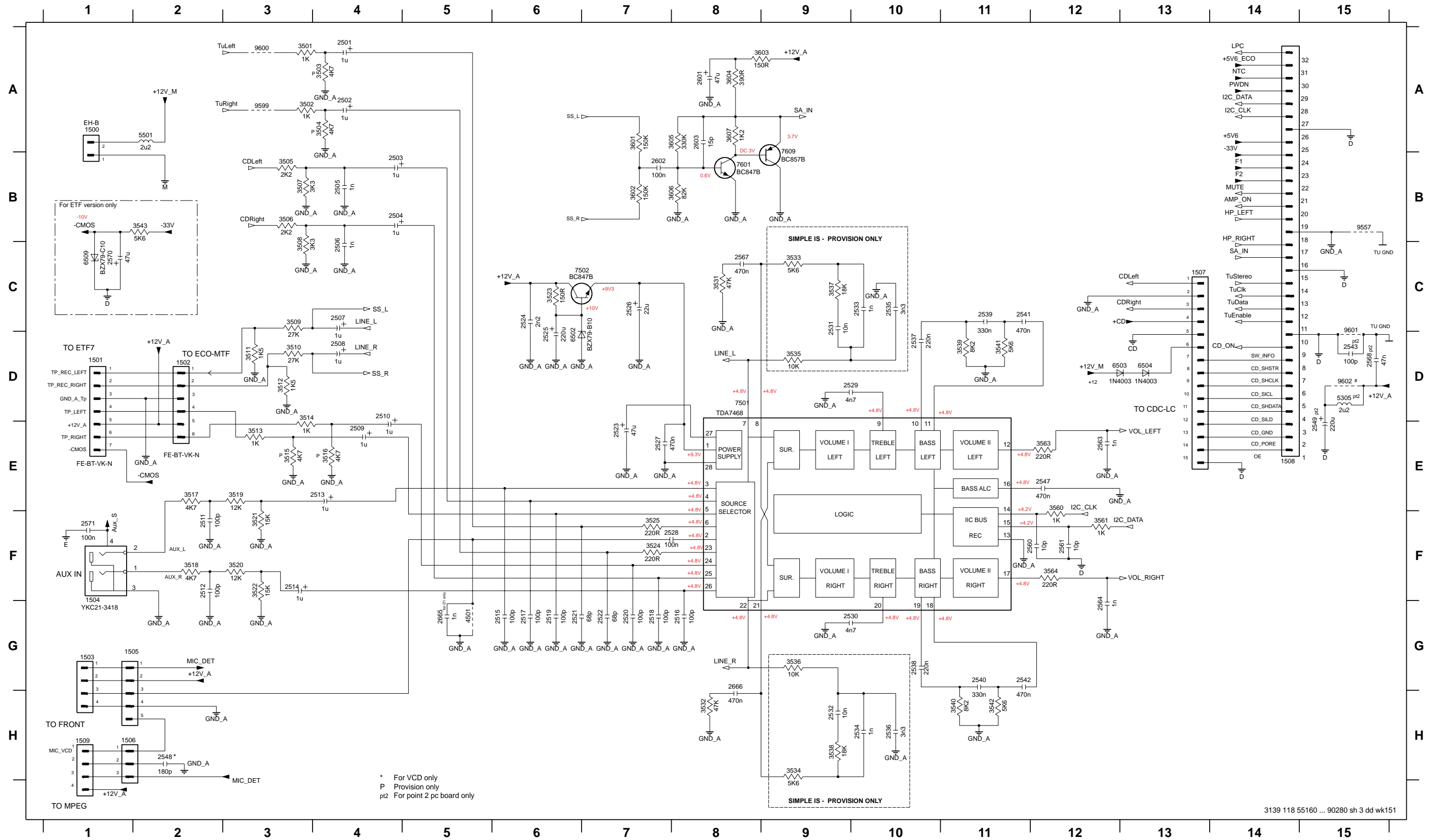

PRE- & POWER AMPLIFIER CIRCUIT

0888 E13	1323 E14	2365 E12	2370 F13	2378 E12	2608 D2	2613 G1	2618 E4	3356 E14	3361 E7	3366 F12	3371 E12	3377 B10	3386 C13	3392 C8	3612 D4	3617 B5	3622 G1	3627 E4	3632 A1	5301 D12	6371 B9	6376 E11	7301 E9	7600-B D3	7606 E4
0889 G13	2351 D14	2366 F12	2371 C7	2604 C2	2609 A3	2614 G2	2662 A1	3357 E14	3362 F7	3367 D12	3372 E12	3378 B10	3387 D10	3608 E2	3613 B5	3618 C5	3623 E1	3628 E4	3633 D1	5302 G12	6372 B8	6377 E11	7302 C9	7602 D4	7607 E5
1300-A F13	2352 F14	2367 D12	2372 D8	2605 A2	2610 D3	2615 E2	2663 D1	3358 F14	3363 E7	3368 G12	3373 E12	3379 D10	3388 D10	3609 A4	3614 D5	3619 B5	3624 F3	3629 F5	3634 B2	5303 E12	6373 C8	6378 F12	7303 C10	7603 B5	7608 B4
1300-B E13	2361 E7	2368 F13	2373 C10	2606 C2	2611 B6	2616 E2	2664 A2	3359 E14	3364 E7	3369 D12	3374 E11	3384 B13	3389 C9	3610 D4	3615 A5	3620 C5	3625 F3	3630 A1	3635 B2	5304 F12	6374 C10	6379 E12	7304 C10	7604 D5	9508 G14
1322 E14	2362 E7	2369 E12	2377 C14	2607 B2	2612 D6	2617 F4	3355 D14	3360 F14	3365 D12	3370 F12	3376 C9	3385 C14	3390 C9	3611 B4	3616 D5	3621 F1	3626 E4	3631 C1	3636 E2	5601 E2	6375 C11	6380 D11	7600-A A2	7605 F4	9510 D14

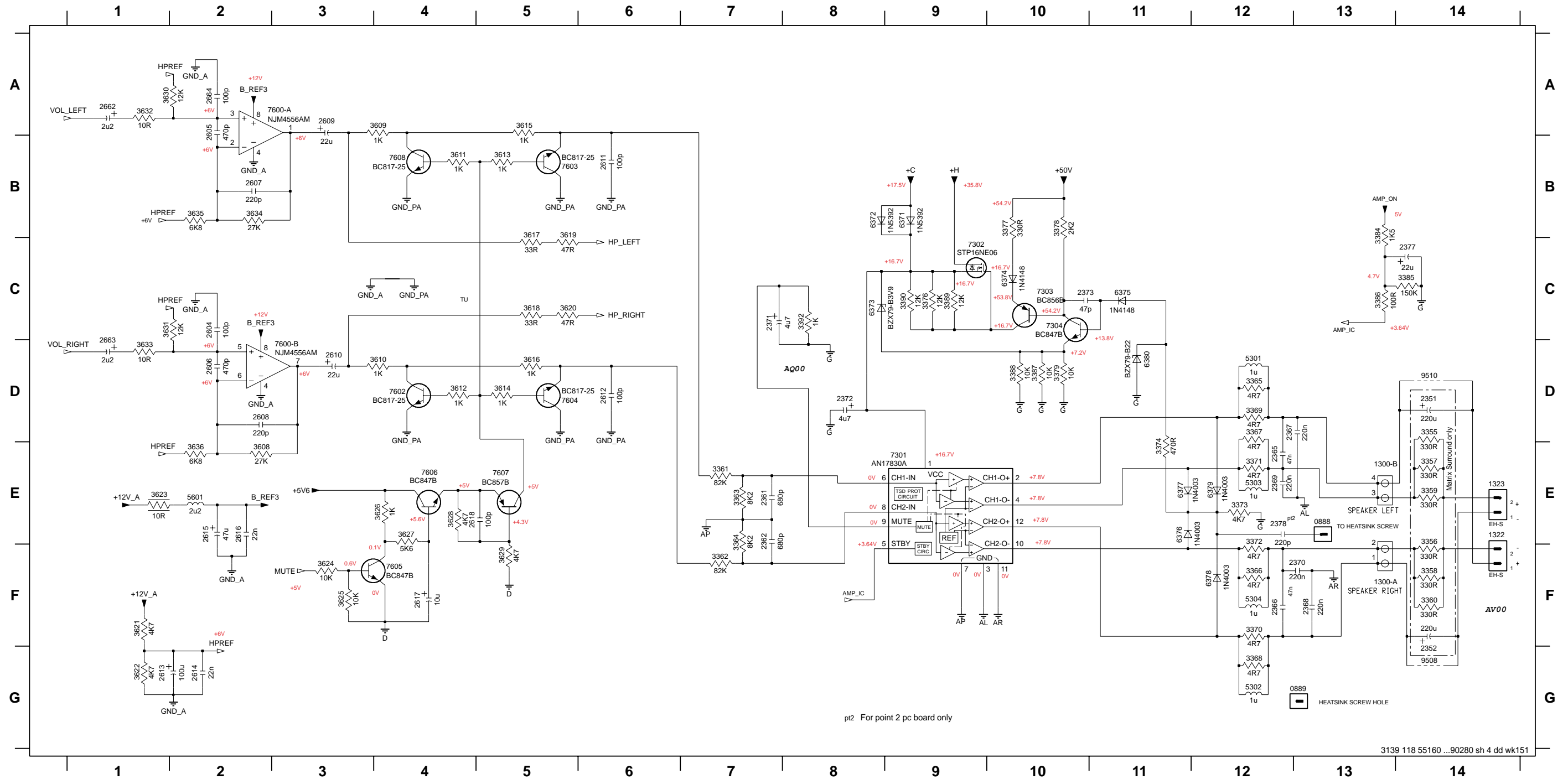

TRANSFORMER PRIMARY PART - CIRCUIT & LAYOUT (except /21/22 version)

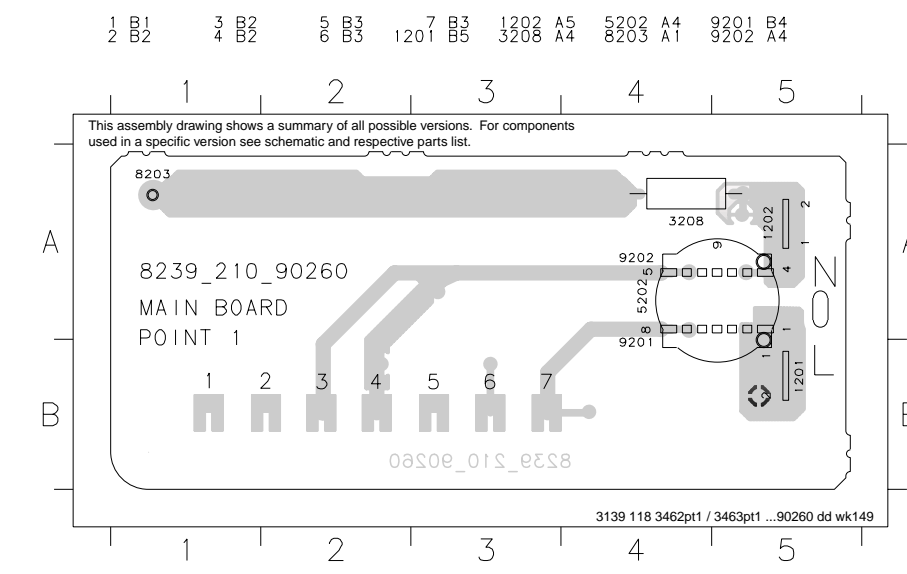
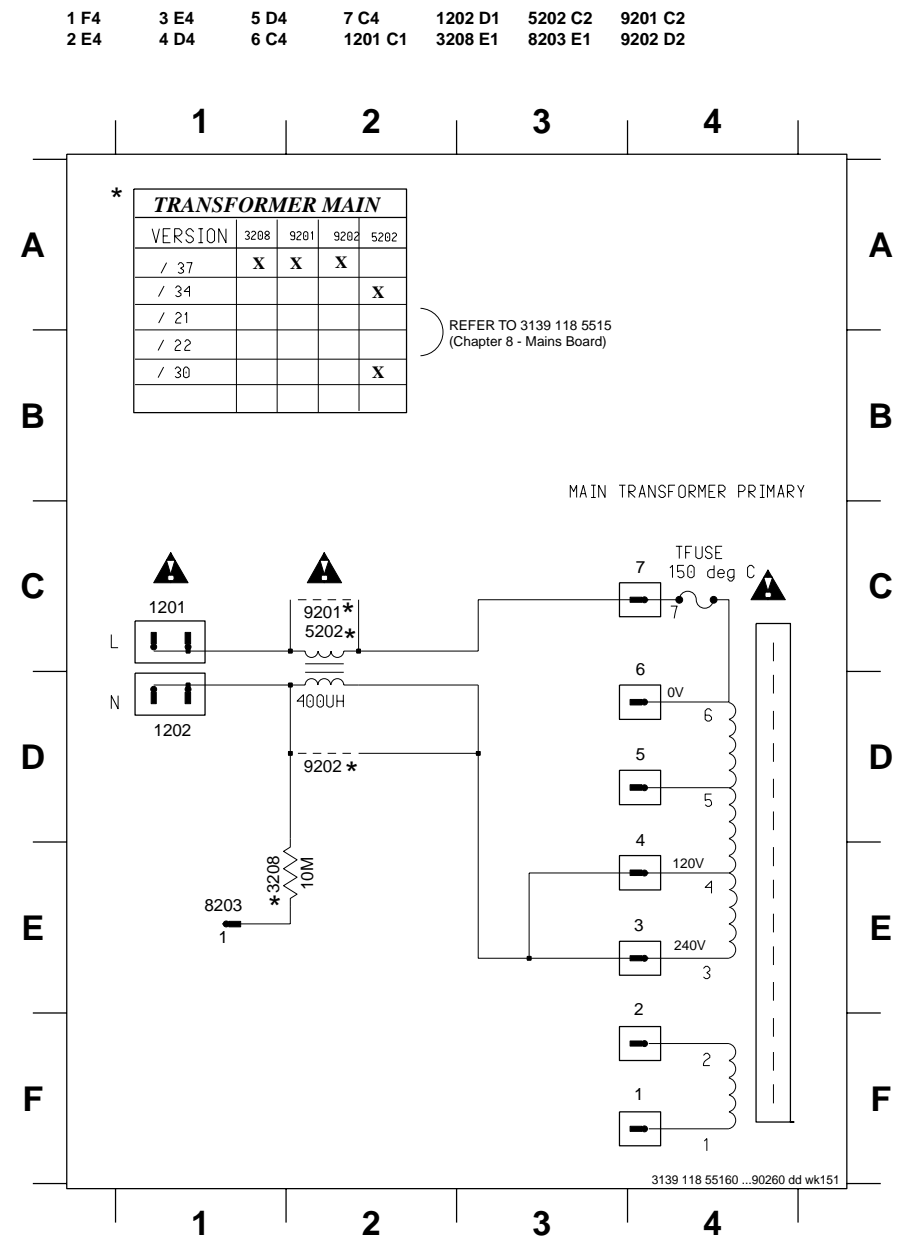

Note: This layout drawing is applicable for both pt 1 and pt 2 pc board.

TRANSFORMER SECONDARY PART - CIRCUIT & LAYOUT (except /21/22 version)

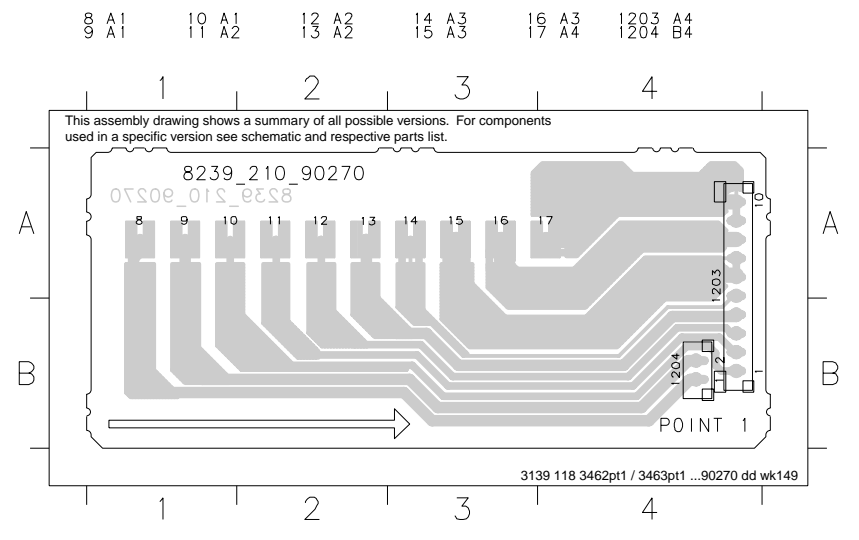
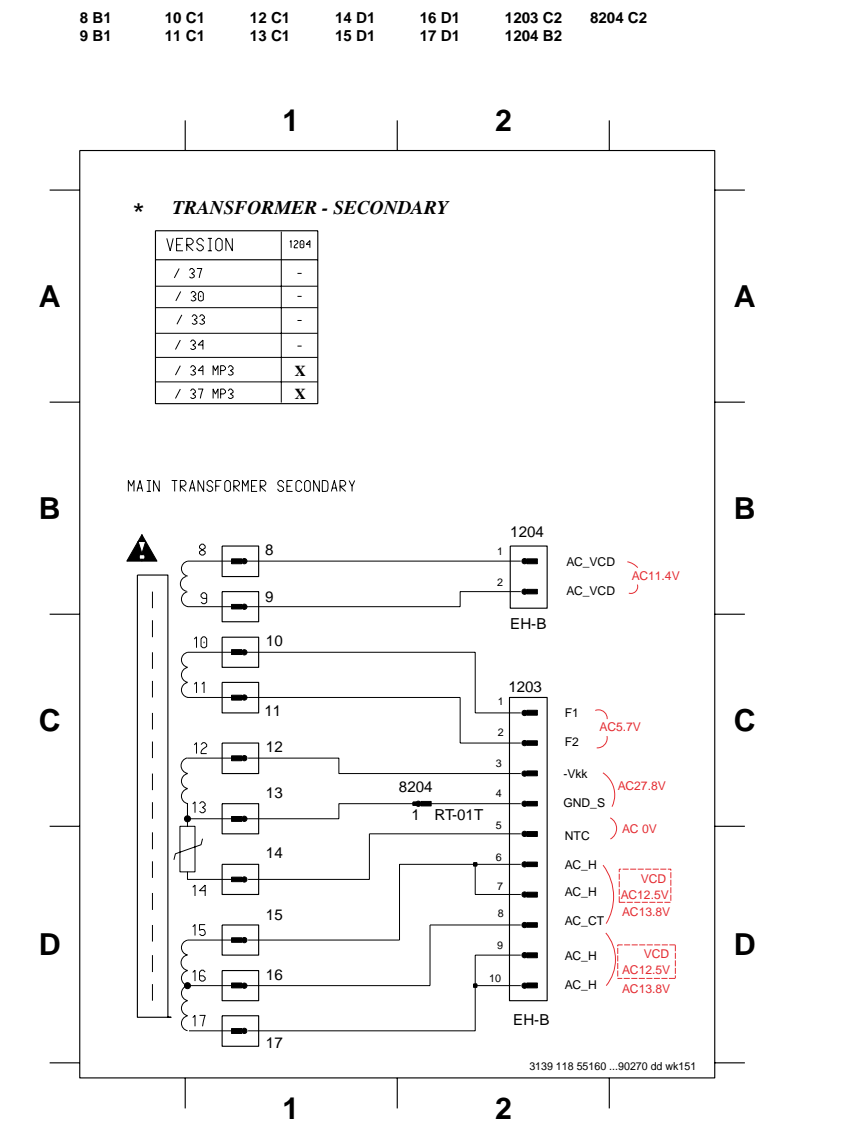

Note: This layout drawing is applicable for both pt 1 and pt 2 pc board.

NON-CENELEC TUNER PORTION - COMPONENT & CHIP LAYOUTS

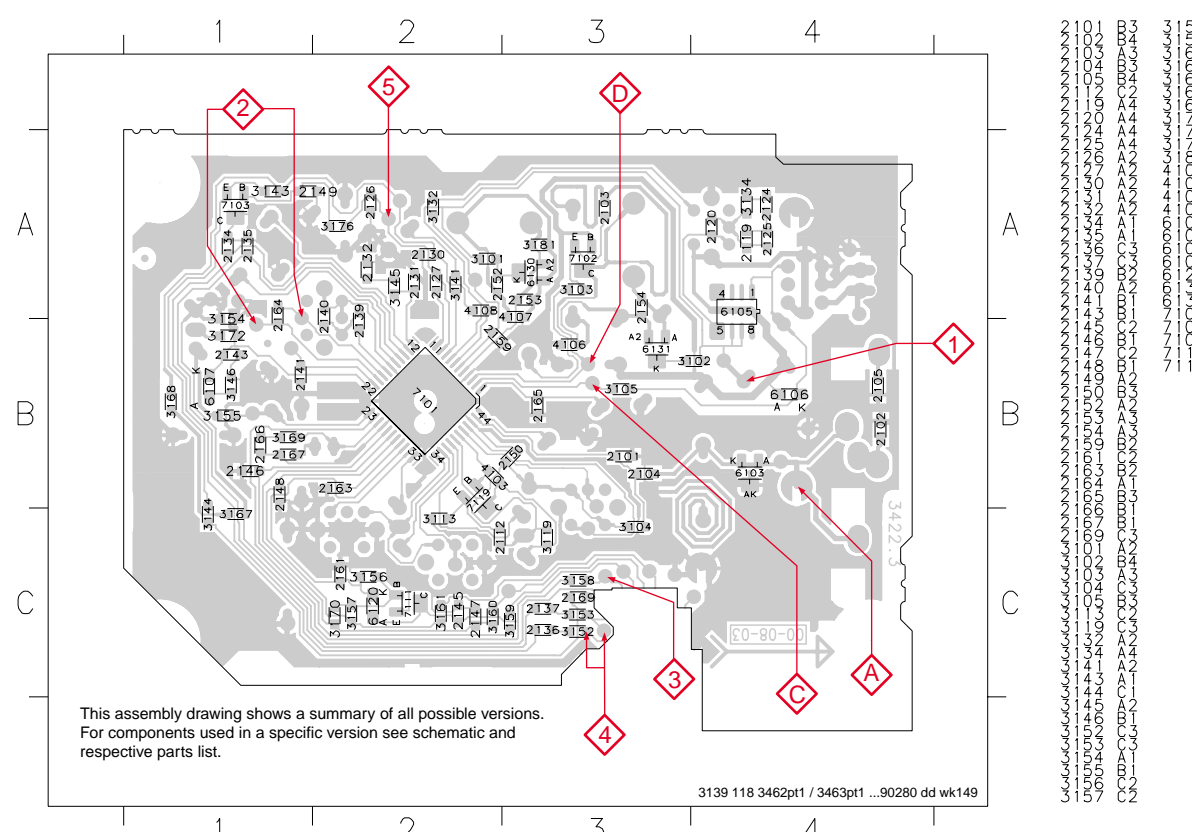
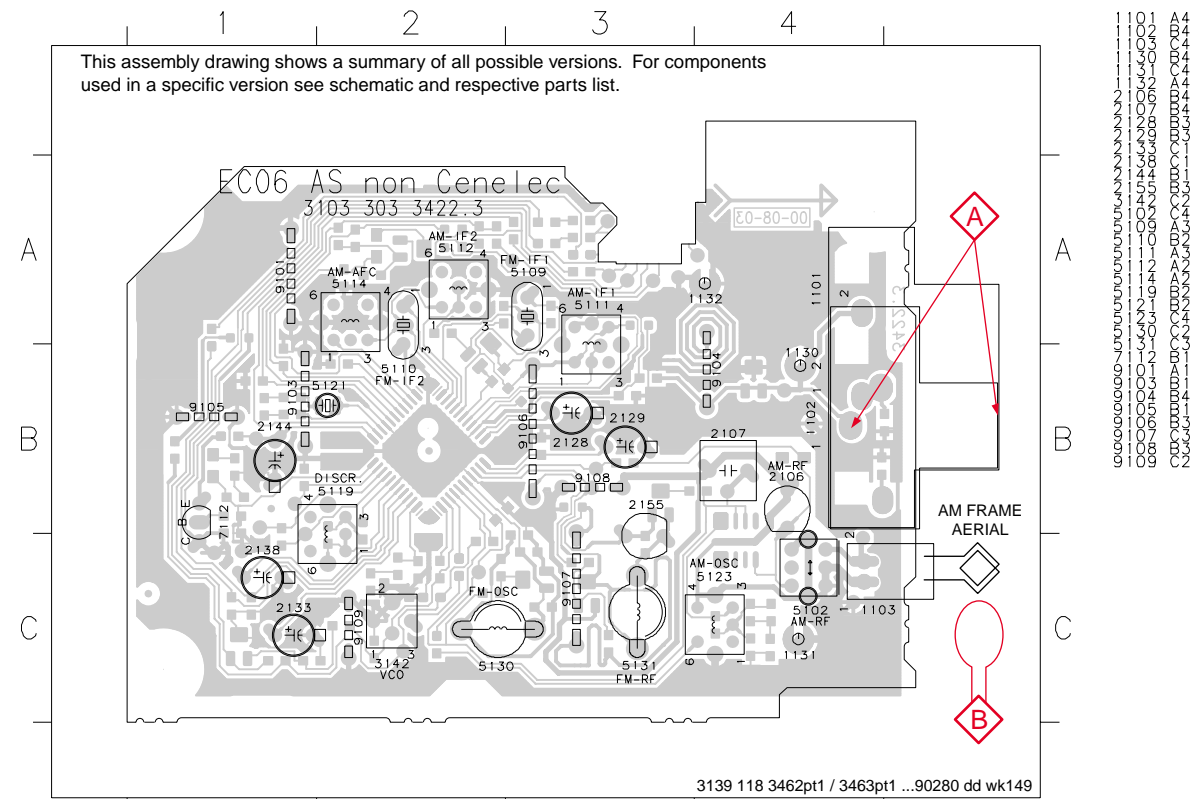

Note: This layout drawings are applicable for both pt 1 and pt 2 pc board.

TUNER ADJUSTMENT TABLE (ECO6 FM/MW- and FM/MW/LW - versions with AM-frame aerial)

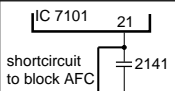
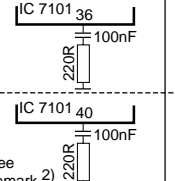
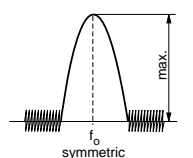
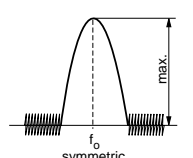
Waverange	Input frequency	Input	Tuned to	Adjust	Output	Scope/Voltmeter
VARICAP ALIGNMENT						
FM 87.5 - 108MHz (65.81 - 74, 87.5 - 108MHz)			108MHz	5130		8V ±0.2V
			87.5MHz (65.81MHz)	check		4.3V ±0.5V (1.2V ±0.5V)
MW FM/AM-version, 10kHz grid 530 - 1700kHz			1700kHz	5123		8V ±0.2V
			530kHz	check	1	1.1V ±0.4V
FM/MW-version, 9kHz grid 531 - 1602kHz			1602kHz	5123		6.9V ±0.2V
			531kHz	check		1.1V ±0.4V
LW 153 - 279kHz			279kHz	5122		8V ±0.2V
			153kHz	check		1.1V ±0.4V
MW FM/MW/LW- version, 9kHz grid 531 - 1602kHz			1602kHz	5123		8V ±0.2V
			531kHz	check		1.1V ±0.4V
FM IF						
FM	10.7MHz, 45mV continuous wave	D		5119	2	0 ± 3 mV DC
FM RF						
FM 87.5 - 108MHz (65.81 - 74, 87.5 - 108MHz)	108MHz	A	108MHz	2155	4	MAX
	87.5MHz (65.81MHz)	mod=1kHz Δf=±22.5kHz	87.5MHz (65.81MHz)	5131		
VCO						
FM	98MHz, 1mV continuous wave	A	98MHz	3142	3	152kHz ±1kHz ¹⁾
AM IF						
MW	450kHz connect pin 6 of IC 7101 (AM Osc.) with 3.3kΩ to Vcc	C Δf=±10kHz V _{RF} = 0.5mV (as low as possible)		5111	5	
				5112		
AM AFC		C		5114	2	0 ± 2 mV DC
AM RF ³⁾						
MW ⁴⁾ FM/MW/LW- and FM/MW-version (9kHz grid) 531 - 1602kHz	1494kHz	B	1494kHz	2106	5	
	558kHz		558kHz	5102		
LW	198kHz		198kHz	5103		
MW FM/AM-version, 10kHz grid 530 - 1700kHz	1500kHz	Δf = ±30kHz V _{RF} as low as possible	1500kHz	2106		
	560kHz		560kHz	5102		

Use Service Testprogram. By selecting the TUNER TEST test frequencies will be stored as preset frequencies automatically.

¹⁾ If sensitivity of frequency counter is too low adjust to max. channel separation (input signal: stereo left 90% + 9%, adjust output on right channel to minimum)

²⁾ RC network serves for damping the IF-filter while adjusting the other one.

³⁾ For AM RF adjustments the original frame antenna has to be used !

⁴⁾ MW has to be aligned before LW.

↑ Repeat

NON-CENELEC TUNER CIRCUIT

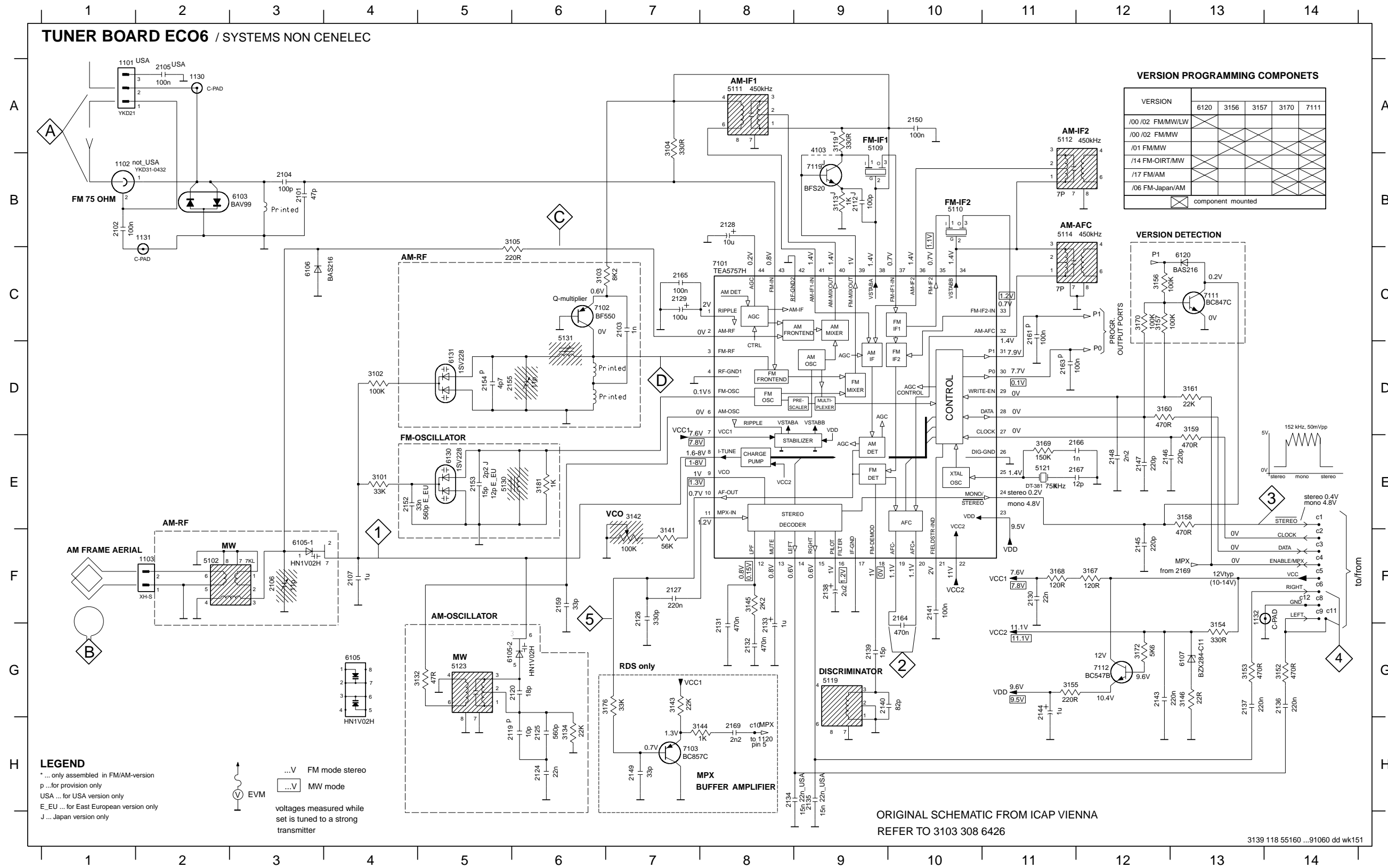

- c1 E14
- c2 F14
- c3 F14
- c4 F14
- c5 F14
- c6 F14
- c8 F14
- c10 H8
- c11 F14
- c12 F14
- c101 A1
- c102 B1
- c103 F2
- c104 A2
- c105 B2
- c106 F3
- c107 G3
- c108 B3
- c109 B1
- c110 C7
- c111 A3
- c112 B3
- c113 G3
- c114 B3
- c115 A2
- c116 B2
- c117 G6
- c118 B8
- c119 C8
- c120 C6
- c121 B2
- c122 G6
- c123 B1
- c124 C7
- c125 B3
- c126 A2
- c127 F4
- c128 B9
- c129 H6
- c130 G6
- c131 H6
- c132 H6
- c133 H6
- c134 F7
- c135 B8
- c136 C7
- c137 F1
- c138 G8
- c139 G8
- c140 G8
- c141 F10
- c142 G12
- c143 G11
- c144 F12
- c145 E12
- c146 E12
- c147 E12
- c148 E12
- c149 H7
- c150 A10
- c151 E4
- c152 E5
- c153 E5
- c154 D5
- c155 D6
- c156 F6
- c157 C11
- c158 D11
- c159 F10
- c160 C7
- c161 E12
- c162 E12
- c163 H8
- c164 E4
- c165 D4
- c166 C6
- c167 A7
- c168 B6
- c169 B9
- c170 A9
- c171 G5
- c172 G5
- c173 H6
- c174 F7
- c175 G7
- c176 G7
- c177 H8
- c178 F8
- c179 G13
- c180 G14
- c181 G13
- c182 G13
- c183 G11
- c184 G11
- c185 G11
- c186 C12
- c187 C12
- c188 E13
- c189 D13
- c190 D12
- c191 D10
- c192 F10
- c193 F11
- c194 E11
- c195 C12
- c196 C12
- c197 G12
- c198 G7
- c199 E6
- c200 A9
- c201 F2
- c202 A9
- c203 B10
- c204 A8
- c205 A11
- c206 B11
- c207 B11
- c208 G9
- c209 E11
- c210 G5
- c211 E5
- c212 E5
- c213 C6
- c214 F3
- c215 G6
- c216 F3
- c217 C8
- c218 C6
- c219 E5
- c220 D5
- c221 C8
- c222 C6
- c223 H7
- c224 G12
- c225 G12
- c226 B9
- c227 G9
- c228 G9
- c229 F10
- c230 G12
- c231 G11
- c232 F12
- c233 E12
- c234 E12
- c235 H7
- c236 A10
- c237 G8
- c238 G8
- c239 G8
- c240 G8
- c241 F10
- c242 G12
- c243 G11
- c244 F12
- c245 E12
- c246 E12
- c247 E12
- c248 E12
- c249 H7
- c250 A10
- c251 E4
- c252 E5
- c253 E5
- c254 D5
- c255 D6
- c256 F6
- c257 C11
- c258 D11
- c259 F10
- c260 C7
- c261 E12
- c262 E12
- c263 H8
- c264 E4
- c265 D4
- c266 C6
- c267 A7
- c268 B6
- c269 B9
- c270 A9
- c271 G5
- c272 G5
- c273 H6
- c274 F7
- c275 G7
- c276 G7
- c277 H8
- c278 F8
- c279 G13
- c280 G14
- c281 G13
- c282 G13
- c283 G11
- c284 G11
- c285 G11
- c286 C12
- c287 C12
- c288 E13
- c289 D13
- c290 D12
- c291 D10
- c292 F10
- c293 F11
- c294 E11
- c295 C12
- c296 C12
- c297 G12
- c298 G7
- c299 E6
- c300 A9
- c301 F2
- c302 A9
- c303 B10
- c304 A8
- c305 A11
- c306 B11

ELECTRICAL PARTS LIST - COMBI BOARD

MISCELLANEOUS

1101	2422 015 19376	Socket 2P Clickfit /37	2150	4822 126 14585	100nF 10% 50V
1102	4822 267 10283	Socket Coaxial 75R /21/21M/30	2152	4822 126 14549	33nF 16V
1103	4822 265 31184	JST Connector 2P	2153	4822 122 33752	15pF 5% 50V
1214	4822 071 55002	△ Fuse T5A 250V /30/37	2155	2020 800 00191	Trimmer 3-11pF 100V
1215	4822 071 55002	△ Fuse T5A 250V /21/21M/30	2159	2222 867 15339	33pF 50V
1215	4822 252 51123	△ Fuse T5A 250V /37	2164	3198 017 44740	470nF 10V
1216	9965 000 07788	Fuse T2A 250V /21/21M/30	2165	4822 126 14305	100nF 10% 16V
1216	4822 253 10128	Fuse T2A 250V /37	2166	5322 126 11578	1nF 10% 50V
1217	4822 071 53151	Fuse T315mA 250V /21/21M/30	2167	4822 126 11663	12pF 50V
1217	4822 252 51151	Fuse T315mA 250V /37	2201	4822 124 40248	10µF 20% 63V
1300	4822 267 31176	Loudspeaker Socket	2207	4822 121 43526	47nF 10% 63V
1502	4822 267 10731	Flex Socket 6pin Vert.	2208	3198 017 34730	47nF 16V
1503	4822 267 10733	Flex Socket 4pin Vert. /21/21M	2209	5322 126 11578	1nF 50V /37
1504	4822 265 20553	Cinch Socket, Aux-in	2211	4822 124 42367	3300µF 20% 35V
1507	4822 265 10981	Flex Socket 15pin Vert.	2213	5322 121 42386	100nF 5% 63V
1508	2422 025 17411	Flex Socket 30pin Vert.	2214	5322 121 42386	100nF 5% 63V

CAPACITORS

2101	4822 122 33777	47pF 5% 63V	2216	4822 124 80415	4700µF 20% 50V
2102	4822 126 14305	100nF 10% 16V	2218	4822 124 80144	220µF 20% 25V
2103	5322 126 11578	1nF 10% 50V	2220	4822 124 80144	220µF 20% 25V
2104	4822 122 31765	100pF 2% 63V	2221	5322 121 42386	100nF 5% 63V
2105	2238 586 59812	100nF +80/-20% 50V /37	2222	2020 012 93547	100µF 20% 63V
2106	2020 800 00191	Trimmer 3-11pF 100V	2224	4822 124 21913	1µF 20% 63V
2107	4822 121 51319	1µF 10% 63V	2225	4822 124 21913	1µF 20% 63V
2120	4822 126 14507	18pF 5% 50V	2226	4822 121 43526	47nF 5% 250V
2124	4822 126 14494	22nF 10% 25V	2231	5322 126 11583	10nF 10% 50V
2125	2238 861 18561	560pF 1% 50V	2232	4822 126 14494	22nF 25V /30/37
2126	4822 126 14241	330pF 50V	2233	4822 124 41751	47µF 20% 50V
2127	4822 126 13879	220nF +80/-20% 16V	2249	4822 121 43526	47nF 5% 250V .1 pc board only
2128	4822 124 40248	10µF 20% 63V	2361	3198 016 36810	680pF 25V
2129	4822 124 41584	100µF 20% 10V	2362	3198 016 36810	680pF 25V
2130	4822 126 14494	22nF 10% 25V	2365	4822 121 43526	47nF 5% 250V
2131	3198 017 44740	470nF 10V	2366	4822 121 43526	47nF 5% 250V
2132	3198 017 44740	470nF 10V	2367	4822 121 42408	220nF 5% 63V
2133	4822 124 21913	1µF 20% 63V	2368	4822 121 42408	220nF 5% 63V
2134	3198 017 31530	15nF 50V /21/21M/30	2369	4822 121 42408	220nF 5% 63V
2134	4822 126 14494	22nF 25V /37	2370	4822 121 42408	220nF 5% 63V
2135	3198 017 31530	15nF 50V /21/21M/30	2371	4822 124 40769	4,7µF 20% 100V
2135	4822 126 14494	22nF 25V /37	2372	4822 124 40769	4,7µF 20% 100V
2136	4822 126 13879	220nF +80/-20% 16V	2373	4822 122 33777	47pF 5% 63V
2137	4822 126 13879	220nF +80/-20% 16V	2377	4822 124 81151	22µF 50V
2138	4822 124 22652	2,2µF 20% 50V	2378	4822 126 13883	220pF 5% 50V .2 pcb onwards
2139	4822 122 33752	15pF 5% 50V	2501	4822 124 22466	1µF 20% 50V
2140	4822 126 14226	82pF 5% 50V	2502	4822 124 22466	1µF 20% 50V
2141	4822 126 14305	100nF 10% 16V	2503	4822 124 22466	1µF 20% 50V
2143	4822 126 13879	220nF +80/-20% 16V	2504	4822 124 22466	1µF 20% 50V
2144	4822 124 21913	1µF 20% 63V	2505	3198 016 31020	1nF 25V
2145	4822 126 13883	220pF 5% 50V	2506	3198 016 31020	1nF 25V
2146	4822 126 13883	220pF 5% 50V	2507	4822 124 22466	1µF 20% 50V
2147	4822 126 13883	220pF 5% 50V	2508	4822 124 22466	1µF 20% 50V
2148	4822 126 14238	2,2nF 50V	2509	4822 124 22466	1µF 20% 50V
			2510	4822 124 22466	1µF 20% 50V
			2511	4822 122 31765	100pF 2% 63V

ELECTRICAL PARTS LIST - COMBI BOARD

2512	4822 122 31765	100pF 2% 63V	2617	4822 124 40248	10µF 20% 63V
2513	4822 124 22466	1µF 20% 50V	2618	4822 122 31765	100pF 2% 63V
2514	4822 124 22466	1µF 20% 50V	2662	4822 124 22652	2,2µF 20% 50V
2515	4822 122 31765	100pF 2% 63V	2663	4822 124 22652	2,2µF 20% 50V
2516	4822 122 31765	100pF 2% 63V	2664	4822 122 31765	100pF 2% 63V
2517	4822 122 31765	100pF 2% 63V	2665	5322 126 11578	1nF 10% 50V /21/21M
2518	4822 122 31765	100pF 2% 63V	2666	3198 017 44740	470nF 10V
2519	4822 122 31765	100pF 2% 63V	2667	2020 012 93547	100µF 20% 63V
2520	4822 122 31765	100pF 2% 63V			
2521	4822 126 13956	68pF 5% 63V			
2522	4822 126 13956	68pF 5% 63V			
2523	4822 124 40433	47µF 20% 25V			
2524	4822 126 14238	2,2nF 50V			
2525	4822 124 40196	220µF 20% 16V			
2526	4822 124 81151	22µF 50V			
2527	3198 017 44740	470nF 10V			
2528	4822 126 14305	100nF 10% 16V			
2529	4822 126 13193	4,7nF 10% 63V			
2530	4822 126 13193	4,7nF 10% 63V			
2537	4822 121 42408	220nF 5% 63V			
2538	4822 121 42408	220nF 5% 63V			
2539	5322 121 42661	330nF 5% 63V			
2540	5322 121 42661	330nF 5% 63V			
2541	4822 121 51252	470nF 5% 63V			
2542	4822 121 51252	470nF 5% 63V			
2543	4822 122 31765	100pF 2% 63V .2 pcb onwards			
2546	4822 126 14305	100nF 10% 16V			
2547	3198 017 44740	470nF 10V			
2549	4822 124 80144	220µF 20% 25V .2 pcb onwards			
2560	4822 122 33741	10pF 10% 50V			
2561	4822 122 33741	10pF 10% 50V			
2563	3198 016 31020	1nF 25V			
2564	3198 016 31020	1nF 25V			
2567	3198 017 44740	470nF 10V			
2568	3198 017 34730	47nF 16V /37 ?			
2571	4822 126 14305	100nF 10% 16V .1 pc board only			
2601	4822 124 40433	47µF 20% 25V			
2602	4822 126 14305	100nF 10% 16V			
2603	4822 122 33752	15pF 5% 50V			
2604	4822 122 31765	100pF 2% 63V			
2605	4822 126 13881	470pF 5% 50V			
2606	4822 126 13881	470pF 5% 50V			
2607	4822 126 13883	220pF 5% 50V			
2608	4822 126 13883	220pF 5% 50V			
2609	4822 124 81151	22µF 50V			
2610	4822 124 81151	22µF 50V			
2611	4822 122 31765	100pF 2% 63V			
2612	4822 122 31765	100pF 2% 63V			
2613	4822 124 41584	100µF 20% 10V			
2614	4822 126 14494	22nF 10% 25V			
2615	4822 124 41751	47µF 20% 50V			
2616	4822 126 14494	22nF 10% 25V			

RESISTORS

3101	4822 051 30333	33k 5% 0,062W
3102	4822 117 13632	100k 1% 0,062W
3103	4822 117 12902	8k2 1% 0,063W
3104	4822 117 13577	330R 1% 0,1W
3105	4822 051 30221	220R 5% 0,062W
3132	4822 051 30479	47R 5% 0,062W
3134	4822 051 30223	22k 5% 0,062W
3141	4822 051 30563	56k 5% 0,062W
3142	4822 100 12159	Trimpot 100k 30%
3145	4822 051 30222	2k2 5% 0,062W
3146	4822 117 12139	22R 5% 0,062W
3152	4822 051 30471	470R 5% 0,062W
3153	4822 051 30471	470R 5% 0,062W
3154	4822 051 30331	330R 5% 0,062W
3155	4822 051 30221	220R 5% 0,062W
3156	4822 117 13632	100k 1% 0,062W /21/21M/30
3158	4822 051 30471	470R 5% 0,062W
3159	4822 051 30471	470R 5% 0,062W
3160	4822 051 30471	470R 5% 0,062W
3161	4822 051 20223	22k 5% 0,1W
3167	4822 051 20121	120R 5% 0,1W
3168	4822 051 30121	120R 5% 0,062W
3169	4822 051 30154	150k 5% 0,062W
3170	4822 117 13632	100k 1% 0,062W
3172	4822 051 30562	5k6 5% 0,063W
3181	4822 051 30102	1k 5% 0,062W
3208	4822 053 21106	10M 5% 0,5W /37
3210	4822 050 24708	4R7 1% 0,6W
3211	4822 050 24708	4R7 1% 0,6W
3212	4822 116 52175	100R 5% 0,5W
3213	4822 116 52175	100R 5% 0,5W
3214	4822 116 83872	220R 5% 0,5W
3215	4822 116 83872	220R 5% 0,5W
3216	4822 116 52175	100R 5% 0,5W
3218	4822 116 52199	68R 5% 0,5W
3219	4822 116 83872	220R 5% 0,5W
3220	4822 116 83872	220R 5% 0,5W
3221	4822 116 52176	10R 5% 0,5W
3222	4822 051 30102	1k 5% 0,062W
3223	4822 050 24708	4R7 1% 0,6W
3224	4822 050 24708	4R7 1% 0,6W
3225	4822 051 30101	100R 5% 0,062W

ELECTRICAL PARTS LIST - COMBI BOARD**DIODES**

6107	9340 386 90115	BZX284-C11	7303	4822 130 60373	BC856B
6120	4822 130 83757	BAS216 /37	7304	4822 130 60511	BC847B
6130	4822 130 82833	1SV228	7501	9322 150 74668	TDA7468D
6131	4822 130 82833	1SV228	7502	4822 130 60511	BC847B
6207	4822 130 34173	BZX79-B5V6	7504	4822 130 41246	BC327-25
6210	4822 130 10944	GBU6D	7600	4822 209 31378	NJM4556MB
6245	4822 130 31878	1N4003G	7601	4822 130 60511	BC847B
6246	4822 130 31878	1N4003G	7602	4822 130 42804	BC817-25
6247	4822 130 31878	1N4003G	7603	4822 130 42804	BC817-25
6248	4822 130 31878	1N4003G	7604	4822 130 42804	BC817-25
6249	4822 130 31878	1N4003G	7605	4822 130 60511	BC847B
6250	4822 130 31878	1N4003G	7606	4822 130 60511	BC847B
6251	4822 130 34174	BZX79-B4V7	7607	4822 130 60373	BC857B
6252	4822 130 30621	1N4148	7608	4822 130 42804	BC817-25
6255	4822 130 31878	1N4003G	7609	4822 130 60373	BC857B
6256	4822 130 31878	1N4003G			
6257	4822 130 34142	BZX79-B33			
6258	4822 130 30621	1N4148			
6259	4822 130 30621	1N4148			
6260	4822 130 34173	BZX79-B5V6			
6267	4822 130 34173	BZX79-B5V6			
6371	4822 130 31878	1N5392			
6372	4822 130 31878	1N5392			
6373	3198 010 53980	BZX79-B3V9			
6374	4822 130 30621	1N4148			
6375	4822 130 30621	1N4148			
6376	4822 130 31878	1N4003G			
6377	4822 130 31878	1N4003G			
6378	4822 130 31878	1N4003G			
6379	4822 130 31878	1N4003G			
6380	3198 010 52290	BZX79-B22			
6502	4822 130 61219	BZX79-B10			
6503	4822 130 31878	1N4003G			
6504	4822 130 31878	1N4003G			

Note: Only the parts mentioned in this list are normal service spare parts.

TRANSISTORS & INTEGRATED CIRCUITS

7101	9351 740 80557	TEA5757H/V1
7102	4822 130 42131	BF550
7111	5322 130 42755	BC847C
7112	4822 130 40959	BC547B
7209	4822 130 40981	BC337-25
7210	4822 130 40981	BC337-25
7211	4822 130 40981	BC337-25
7212	4822 130 40981	BC337-25
7213	4822 130 40981	BC337-25
7214	4822 209 33575	L7812CP
7215	5322 130 44593	BC369
7216	4822 130 40981	BC337-25
7217	4822 130 41246	BC327-25
7219	4822 130 60511	BC847B
7301	9322 174 32682	AN17830A
7302	4822 130 11578	STP16NE06

EXPLODED VIEW - MAIN UNIT

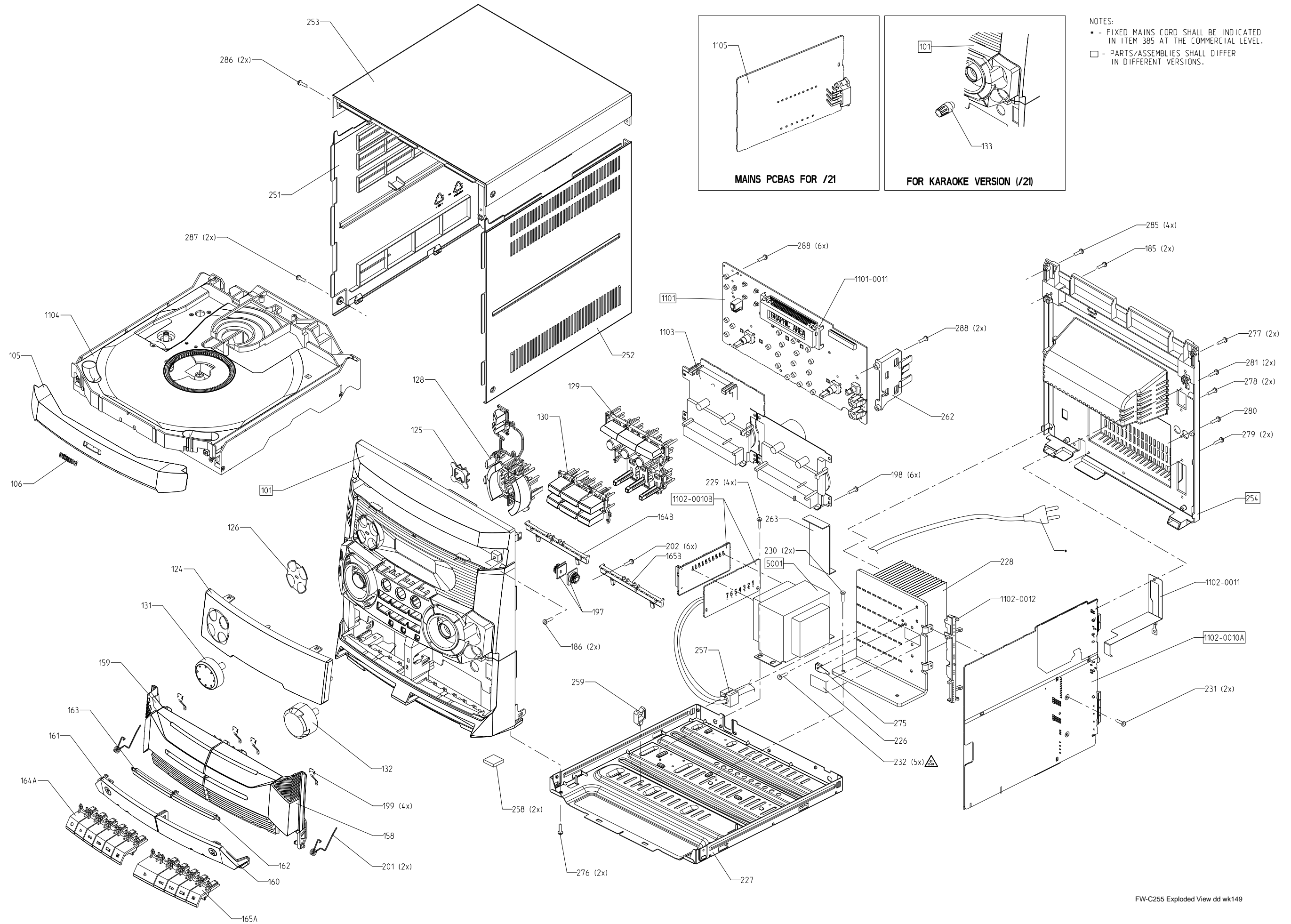

NOTES:
 * - FIXED MAINS CORD SHALL BE INDICATED IN ITEM 385 AT THE COMMERCIAL LEVEL.
 □ - PARTS/ASSEMBLIES SHALL DIFFER IN DIFFERENT VERSIONS.

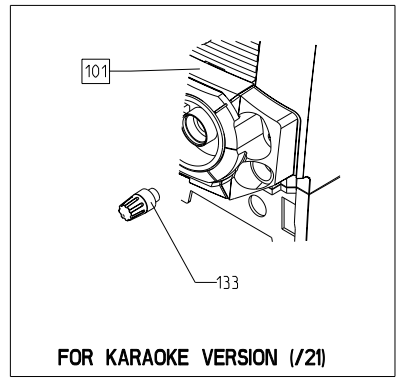
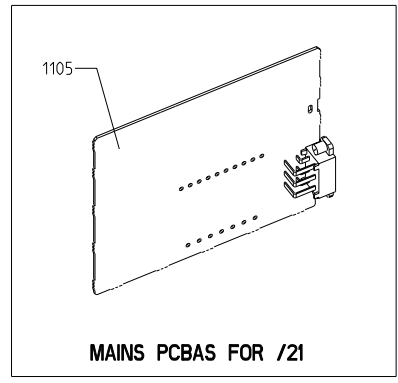

MECHANICAL & ACCESSORIES PARTSLIST

101	9965 000 22414	CAB FRT FW-C270/21
105	9965 000 22415	COVER TRAY CDC
106	4822 454 13408	BADGE PHILIPS
125	9965 000 22416	LIGHTGUIDE SOUND DSC/DBB
128	9965 000 22418	BUTTON SET PWR
129	9965 000 22419	BUTTON SET SRCE
130	9965 000 22420	BUTTON SET CONTROL
131	9965 000 22422	KNOB JOG ROTARY
132	9965 000 22421	KNOB VOL ROTARY
133	9965 000 22423	KNOB KARAOKE
158	9965 000 22424	COVER CASS RT
159	9965 000 22425	COVER CASS LT
160	9965 000 22426	LENS CASS RIGHT
161	9965 000 22427	LENS CASS LEFT
162	9965 000 22428	LENS CASS TOP RIGHT
163	9965 000 22429	LENS CASS TOP LEFT
164	9965 000 22431	BUTTON CASS LT
165	9965 000 22432	BUTTON CASS RT
199	4822 492 70231	SPRING LEAF
201	3139 111 01440	SPRING TORSION CASS MTF
251	9965 000 22382	PANEL LEFT
252	9965 000 22383	PANEL RIGHT
253	9965 000 22384	COVER-TOP
254	9965 000 22430	PANEL REAR2
257	9965 000 18352	BUSHING (2104) CORD
258	9965 000 22433	FOOT RUBBER-1
385	△ 9965 000 14712	MAINS CORD IEC
1103	3139 118 78570	TAPE DECK CDS-83WPC-06
1104	3103 308 54360	3CDC ASSY
1400	9965 000 22407	FFC 30P 150MM 1.25
1500	3139 110 35920	FFC FOIL 04P/140/04P AD
1700	9965 000 22408	FFC 06P 340MM 1.25
1800	9965 000 22409	FFC 15P 180MM 1.25
5001	△ 9965 000 22410	TRANSFORMER 127V/240V
	9965 000 22411	IFU FW-C270/21
	9965 000 11157	FM ANTENNA WIRE
	4822 303 50082	AM LOOP ANTENNA
	△ 9965 000 22395	ADAPTOR CONVERSION 2P
	9965 000 22412	IRT ASSY
	9965 000 22413	SPK BOX FW-C270/21

Note: Only these parts mentioned in the list are normal service parts.

SCREW LISTS - MAIN UNIT

185	D3 x 12
186	D3 x 12
198	D3 x 12
202	D3 x 12
229	M3 x 6
230	M3 x 10
231	M3 x 10
232	M3 x 10
276	M3 x 6
277	M3 x 10
278	M3 x 10
279	D3 x 12
280	D3 x 12
281	D3 x 12
285	D3 x 12
286	D3 x 12
287	M3 x 6
288	D3 x 12