



MISSISSIPPI POWER & LIGHT COMPANY

Helping Build Mississippi

P. O. BOX 1640, JACKSON, MISSISSIPPI 39205

NUCLEAR PRODUCTION DEPARTMENT

May 8, 1984

Office of Nuclear Reactor Regulation
U. S. Nuclear Regulatory Commission
Washington, D. C. 20555

Attention: Mr. Harold R. Denton, Director

Dear Mr. Denton:

SUBJECT: Grand Gulf Nuclear Station
Units 1 and 2
Docket Nos. 50-416 and 50-417
License No. NPF-13
File 0260/L-860.0
Technical Specification
Terminology, ICSB Concerns
AECM-84/0093

- References:
- 1) NRC letter requesting additional information on isolation instrumentation Technical Specification, dated September 12, 1983, from Mr. A. Schwencer to Mr. J. P. McGaughy
 - 2) AECM-83/0519, Letter from Mr. L. F. Dale to Mr. Harold R. Denton, dated September 12, 1983, concerning Technical Specification Terminology, ICSB Concerns
 - 3) AECM-83/0764, Letter from Mr. L. F. Dale to Mr. Harold R. Denton, dated December 15, 1983, concerning Technical Specification Terminology, ICSB Concerns
 - 4) AECM-84/0102, Letter from Mr. L. F. Dale to Mr. Harold R. Denton, dated February 15, 1984, concerning Technical Specification Terminology, ICSB Concerns
 - 5) NRC letter on Technical Specifications Review, dated April 25, 1984, from Elinor G. Adensam to J. P. McGaughy

The Nuclear Regulatory Commission (NRC) requested in Reference 1 and Mississippi Power & Light (MP&L) committed in Reference 2 to provide the NRC with Technical Specification definitions for the terms "channel," "trip system," and "trip function." These definitions were provided in Reference 3 for the instrumentation in Technical Specification Table 3.3.2-1, Isolation Actuation Instrumentation. The attachment to this letter provides these definitions for the remaining instrumentation in Section 3/4.3 of the Technical Specifications, incorporates secondary containment isolation, and makes certain corrections to the submittal from Reference 3. These corrections are to certain instrumentation numbers and to certain actuated equipment, but the basic conclusions of the review are not affected.

8405100038 840508
PDR ADDCK 05000416
P PDR

Boo!
11/80

MISSISSIPPI POWER & LIGHT COMPANY

AECM-84/0093
May 8, 1984
Page 2

The material in the attachment depicts the logic for instrumentation presently in the GGNS Technical Specifications in terms of the definitions. The logic for Suppression Pool Makeup Instrumentation (Page 89) and Division III Undervoltage Breaker Trip Instrumentation (Page 26), although not in the current Technical Specifications, are included since they are associated with several enhancements being considered from the Technical Specification Review Program.

This package was scheduled for submittal on March 15, 1984 as documented in Reference 4. Subsequent discussions with the NRC staff resulted in an informal agreement to allow deferral of the submittal. It was further agreed that the submittal would be made prior to full power licensing and on a schedule consistent with ICSB review of associated changes resulting from this report simultaneously with their review of changes resulting from the Technical Specification Review Program (TSRP).

The review which resulted in the attached report was initiated prior to the TSRP, however, because of the relationship to Technical Specifications, this review was tracked as a part of the TSRP as Technical Specification Problem Sheet (TSPS) 034. All Technical Specification changes resulting from this review have been incorporated into the results of the TSRP and assigned a TSPS number.

This submittal, in conjunction with the TSRP (as discussed above), completes the MP&L response to Reference 1. In addition, Reference 5 formally requested submittal of the report resulting from this review. This letter, therefore, also serves as the formal response to that part of Reference 5 which requested the submittal of the "Generic Instrumentation Review" report associated with TSPS 034.

Please contact this office if additional information is required.

Yours truly,

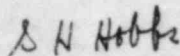

L. F. Dale
Manager of Nuclear Services

WJH/JOF/SHH:mm

Attachments

cc: See Page 3

MISSISSIPPI POWER & LIGHT COMPANY

AECM-84/0093

May 8, 1984

Page 3

cc: Mr. J. B. Richard, (w/a)
Mr. R. B. McGehee (w/o)
Mr. N. S. Reynolds (w/o)
Mr. G. B. Taylor (w/o)

Mr. Richard C. DeYoung, Director (w/a)
Office of Inspection and Enforcement
U. S. Nuclear Regulatory Commission
Washington, D. C. 20555

Mr. J. P. O'Reilly, Regional Administrator (w/a)
U. S. Nuclear Regulatory Commission
Region II
101 Marietta Street, N.W., Suite 2900
Atlanta, Georgia 30303

DEFINITIONS FOR THE TERMS
"CHANNEL", "TRIP SYSTEM", AND "TRIP FUNCTION"
FOR INSTRUMENTATION IN TECHNICAL SPECIFICATION SECTION 3/4.3

The definitions presented in this attachment are provided as both generic and instrumentation specific definitions. The generic definitions apply to all cases where the terms "Channel", "Trip System" and "Trip Functions" are used in the Technical Specifications. Specific definitions are provided in tabular form for each Specification in Technical Specification Section 3/4.3, except those which were provided in a previous submittal.

Generic Definitions

- 1) Channel - A group of devices which is sufficient to produce only one trip signal for only one parameter. A channel consists of all components from sensor through trip unit (or trip relay, when provided).
- 2) Trip System - A group of devices including instrument channels and logic components, which is required to produce a trip of an actuation device or group of actuation devices. The tripping of a trip system may or may not produce a trip function.
- 3) Trip Function - The initiation of actuation devices and equipment necessary to produce the system response required by plant conditions

DEFINITIONS FOR
 "CHANNELS", "TRIP SYSTEMS", AND "TRIP FUNCTIONS"
 FOR REACTOR PROTECTION SYSTEM INSTRUMENTATION TABLE 3.3.1-1 (Continued)

Trip Unit	Parameter	Logic	
C51-K601C	(3)IRM-Neutron Flux High		
C51-K601G	(3)IRM-Neutron Flux High		
C51-K601C	(3)IRM-Inoperative		
C51-K601G	(3)IRM-Inoperative		
C51-Z405C	(3)APRM-Neutron Flux High, Setdown		
C51-Z405G	(3)APRM-Neutron Flux High, Setdown		
C51-Z409C	APRM-Flow Biased Thermal Power-Hi		
C51-Z409G	APRM-Flow Biased Thermal Power-Hi		
C51-Z401C	APRM-Neutron Flux High		
C51-Z401G	APRM-Neutron Flux High		
C51-Z401C	APRM-Inoperative		
C51-Z401G	APRM-Inoperative		
B21-PIS-N678C	*Rx Steam Dome Pressure High		
B21-LIS-N680C	RPV Level 3		
B21-LS-N683C	(1)RPV Level 8		
B21-ZS-N101C	(1)MSIV Closure		Either
B21-ZS-N102C	(1)MSIV Closure		
B21-ZS-N101B	(1)MSIV Closure	Either	
B21-ZS-N102B	(1)MSIV Closure		
D17-RITS-K610C	MSL Radiation High	Both	
C71-PIS-N650C	Drywell Pressure High		
C11-LIS-N601C	SDV Water Level High	Both	
C71-PIS-N606C	(2)Turb Stop Valve Closure		
C71-PIS-N606G	(2)Turb Stop Valve Closure		
C71-PIS-N605C	(2)Turb Control Valve Fast Closure		
C71-HSS-M602	**Rx Mode Switch Shutdown		
C71-HS-M600C	Manual Scram		

TO PAGE 2

(1)

"C" Channels of
TRIP SYSTEM A

- (1) This CHANNEL is automatically bypassed when the Reactor Mode Switch is not in the RUN position.
- (2) This CHANNEL is automatically bypassed when turbine first stage pressure is less than 30% of the value of turbine first stage pressure at valves wide open steam flow, equivalent to less than 40% rated thermal power.
- (3) This CHANNEL is automatically bypassed when the Reactor Mode Switch is in the RUN position.

* One Channel (Typical of 27 shown on this page)

** There is only one Reactor Mode Switch which operates relays in both Trip Systems A and B. The Reactor Mode Switch and its associated contacts constitute one Channel.

DEFINITIONS FOR
 "CHANNELS", "TRIP SYSTEMS", AND "TRIP FUNCTIONS"
 FOR REACTOR PROTECTION SYSTEM INSTRUMENTATION TABLE 3.3.1-1 (Continued)

Trip Unit	Parameter	Logic	
C51-K601B	(3)IRM-Neutron Flux High		
C51-K601F	(3)IRM-Neutron Flux High		
C51-K601B	(3)IRM-Inoperative		
C51-K601F	(3)IRM-Inoperative		
C51-Z405B	(3)APRM-Neutron Flux High, Setdown		
C51-Z405F	(3)APRM-Neutron Flux High, Setdown		
C51-Z409B	APRM-Flow Biased Thermal Power-Hi		
C51-Z409F	APRM-Flow Biased Thermal Power-Hi		
C51-Z401B	APRM-Neutron Flux High		
C51-Z401F	APRM-Neutron Flux High		
C51-Z401B	APRM-Inoperative		
C51-Z401F	APRM-Inoperative		
B21-PIS-N678B	*Rx Steam dome pressure high		
B21-LIS-N680B	RPV Level 3		
B21-LS-N683B	(1)RPV Level 8		
B21-ZS-N101A	(1)MSIV Closure		Either Both Either
B21-ZS-N102A	(1)MSIV Closure		
B21-ZS-N101B	(1)MSIV Closure		
B21-ZS-N102B	(1)MSIV Closure		
ID17-RITS-K610B	MSL Radiation High	Both	
C71-PIS-N650B	Drywell Pressure High		
C11-LIS-N601B	SDV Water Level High	Both	
C71-PIS-N606B	(2)Turb Stop Valve Closure		
C71-PIS-N606F	(2)Turb Stop Valve Closure		
C71-PIS-N605B	(2)Turb Control Valve Fast Closure		
C71-HSS-M602 **	Rx Mode Switch Shutdown		
C71-HS-M600B	Manual Scram	"B" Channels of TRIP SYSTEM B	

Either One
 De-energizes
 Scram Pilot
 Solenoids
 in Trip
 System B

2
 FROM PAGE 5

- (1) This CHANNEL is automatically bypassed when the Reactor Mode Switch is not in the RUN position.
- (2) This CHANNEL is automatically bypassed when turbine first stage pressure is less than 30% of the value of turbine first stage pressure at valves wide open steam flow, equivalent to less than 40% rated thermal power.
- (3) This CHANNEL is automatically bypassed when the Reactor Mode Switch is in the RUN position.

* One Channel (Typical of 27 shown on this page)
 ** There is only one Reactor Mode Switch which operates relays in both trip systems A and B. The Reactor Mode Switch and its associated contacts constitute one Channel.

DEFINITIONS FOR
"CHANNELS", "TRIP SYSTEMS", AND "TRIP FUNCTIONS"
FOR REACTOR PROTECTION SYSTEM INSTRUMENTATION TABLE 3.3.1-1 (Continued)

<u>Trip Unit</u>	<u>Parameter</u>	<u>Logic</u>		
C51-K601D	(3)IRM-Neutron Flux High	} TO PAGE 4 ②		
C51-K601H	(3)IRM-Neutron Flux High			
C51-K601D	(3)IRM-Inoperative			
C51-K601H	(3)IRM-Inoperative			
C51-Z405D	(3)APRM-Neutron Flux High, Setdown			
C51-Z405H	(3)APRM-Neutron Flux High, Setdown			
C51-Z409D	APRM-Flow Biased Thermal Power-Hi			
C51-Z409H	APRM-Flow Biased Thermal Power-Hi			
C51-Z401D	APRM-Neutron Flux High			
C51-Z401H	APRM-Neutron Flux High			
C51-Z401D	APRM-Inoperative			
C51-Z401H	APRM-Inoperative			
B21-PIS-N678D	*Rx Steam Dome Pressure High		} Any One	
B21-LIS-N680D	RPV Level 3			
B21-LS-N683D	(1)RPV Level 8			
B21-ZS-N101D	(1)MSIV Closure			} Either
B21-ZS-N102D	(1)MSIV Closure			
B21-ZS-N101C	(1)MSIV Closure	} Either		
B21-ZS-N102C	(1)MSIV Closure			
D17-RITS-K610D	MSL Radiation High	} Both		
C71-PIS-N650D	Drywell Pressure High			
C11-LIS-N601D	SDV Water Level High	} Both		
C71-PIS-N606D	(2)Turb Stop Valve Closure			
C71-PIS-N606H	(2)Turb Stop Valve Closure			
C71-PIS-N605D	(2)Turb Control Valve Fast Closure	} Both		
C71-HSS-M602	**Rx Mode Switch Shutdown			
C71-HS-M600D	Manual Scram			

"D" Channels of TRIP SYSTEM B

The TRIP FUNCTION (Reactor Scram) is shown below for the Reactor Protection System Instrumentation

<u>Parameter</u>	<u>Channel Logic</u>	<u>Trip System</u>	<u>Logic</u>	<u>Trip Function</u>
"A" Channels	} Either One	SYSTEM A	} Both	REACTOR SCRAM
"C" Channels		SYSTEM B		
"B" Channels	} Either One	SYSTEM B		
"D" Channels		SYSTEM B		

- (1) This CHANNEL is automatically bypassed when the Reactor Mode Switch is not in the RUN position.
- (2) This CHANNEL is automatically bypassed when turbine first stage pressure is less than 30% of the value of turbine first stage pressure at valves wide open steam flow, equivalent to less than 40% rated thermal power.
- (3) This CHANNEL is automatically bypassed when the Reactor Mode Switch is in the RUN position.

* One Channel (Typical of 27 shown on this page)

** There is only one Reactor Mode Switch which operates relays in both trip systems A and B. The Reactor Mode Switch and its associated contacts constitute one Channel.
Llstd20

DEFINITIONS FOR
 "CHANNELS", "TRIP SYSTEMS", AND "TRIP FUNCTIONS"
 FOR ISOLATION ACTUATION INSTRUMENTATION TABLE 3.3.2-1
 GROUP 1 ISOLATION (MSIV CLOSURE)

Trip Unit	Parameter	Logic	
B21-LIS-N681A	RPV Level 1	Any One	
D17-RITS-K610A	MSL radiation-high		
B21-PIS-N676A	MSL pressure-low		
E31-PDIS-N686A	MSL A flow-high		
E31-PDIS-N687A	MSL B flow-high		
E31-PDIS-N688A	MSL C flow-high		
E31-PDIS-N689A	*MSL D flow-high	Either One	
B21-PIS-N675A(1)	Condenser vacuum-low		
E31-TS-N604A	MSL tunnel temp-high		
E31-TDS-N605A	MSL tunnel Δ temp-high		
B21-HS-M630A	Manual initiation		
B21-LIS-N681C	RPV Level 1		
D17-RITS-K610C	MSL radiation-high		
B21-PIS-N676C	MSL pressure-low		
E31-PDIS-N686C	MSL A flow-high		
E31-PDIS-N687C	MSL B flow-high		
E31-PDIS-N688C	MSL C flow-high		
E31-PDIS-N689C	MSL D flow-high		
B21-PIS-N675C(1)	Condenser vacuum-low	TRIP SYSTEM	
E31-TS-N604C	MSL tunnel temp-high		
E31-TDS-N605C	MSL tunnel Δ temp-high		
B21-HS-M630C	Manual initiation		
B21-LIS-N681B	RPV Level 1		Any One
D17-RITS-K610B	MSL radiation-high		
B21-PIS-N676B	MSL pressure-low		
E31-PDIS-N686B	MSL A flow-high		
E31-PDIS-N687B	MSL B flow-high		
E31-PDIS-N688B	MSL C flow-high		
E31-PDIS-N689B	MSL D flow-high		Either One
B21-PIS-N675B(1)	Condenser vacuum-low		
E31-TS-N604B	MSL tunnel temp-high		
E31-TDS-N605B	MSL tunnel Δ temp-high		
B21-HS-M630B	Manual initiation		
B21-LIS-N681D	RPV Level 1		
D17-RITS-K610D	MSL radiation-high		
B21-PIS-N676D	MSL pressure-low		
E31-PDIS-N686D	MSL A flow-high		
E31-PDIS-N687D	MSL B flow-high		
E31-PDIS-N688D	MSL C flow-high		
E31-PDIS-N689D	MSL D flow-high		
B21-PIS-N675D(1)	Condenser vacuum-low	TRIP SYSTEM	
E31-TS-N604D	MSL tunnel temp-high		
E31-TDS-N605D	MSL tunnel Δ temp-high		
B21-HS-M630D	Manual Initiation		

Both - Close MSIV's TRIP FUNCTION

* One Channel (typical of 44 shown on this page)

(1) May be manually bypassed when condenser vacuum is below the trip setpoint in Operational Conditions 2, 3, 4, or 5.

DEFINITIONS FOR
 "CHANNELS", "TRIP SYSTEMS", AND "TRIP FUNCTIONS"
 FOR ISOLATION ACTUATION INSTRUMENTATION TABLE 3.3.2-1 (Continued)
 GROUP 1 ISOLATION (MSL DRAIN CLOSURE)

Trip Unit	Parameter	Logic	
B21-LIS-N681A	RPV Level 1	Any One	
D17-RITS-K610A	MSL radiation-high		
B21-PIS-N676A	MSL pressure-low		
E31-PDIS-N686A	MSL A flow-high		
E31-PDIS-N687A	MSL B flow-high		
E31-PDIS-N688A	MSL C flow-high		
E31-PDIS-N689A	*MSL D flow-high		
B21-PIS-N675A(1)	Condenser vacuum-low	Both	Close outboard MSL drain valves TRIP FUNCTION
E31-TS-N604A	MSL tunnel temp-high		
E31-TDS-N605A	MSL tunnel Δ temp-high		
B21-HS-M630A	Manual initiation		
B21-LIS-N681D	RPV Level 1		
D17-RITS-K610D	MSL radiation-high	Any One	
B21-PIS-N676D	MSL pressure-low		
E31-PDIS-N686D	MSL A flow-high		
E31-PDIS-N687D	MSL B flow-high		
E31-PDIS-N688D	MSL C flow-high		
E31-PDIS-N689D	MSL D flow-high		
B21-PIS-N675D(1)	Condenser vacuum-low	Both	TRIP SYSTEM
E31-TS-N604D	MSL tunnel temp-high		
E31-TDS-N605D	MSL tunnel Δ temp-high		
B21-HS-M630D	Manual initiation		
B21-LIS-N681B	RPV Level 1	Any One	
D17-RITS-K610B	MSL radiation-high		
B21-PIS-N676B	MSL pressure-low		
E31-PDIS-N686B	MSL A flow-high		
E31-PDIS-N687B	MSL B flow-high		
E31-PDIS-N688B	MSL C flow-high		
E31-PDIS-N689B	MSL D flow-high		
B21-PIS-N675B(1)	Condenser vacuum-low	Both	Close inboard MSL drain valves TRIP FUNCTION
E31-TS-N604B	MSL tunnel temp-high		
E31-TDS-N605B	MSL tunnel Δ temp-high		
B21-HS-M630B	Manual initiation		
B21-LIS-N681C	RPV Level 1		
D17-RITS-K610C	MSL radiation-high	Any One	
B21-PIS-N676C	MSL pressure-low		
E31-PDIS-N686C	MSL A flow-high		
E31-PDIS-N687C	MSL B flow-high		
E31-PDIS-N688C	MSL C flow-high		
E31-PDIS-N689C	MSL D flow-high		
B21-PIS-N675C(1)	Condenser vacuum-low	Both	TRIP SYSTEM
E31-TS-N604C	MSL tunnel temp-high		
E31-TDS-N605C	MSL tunnel Δ temp-high		
B21-HS-M630C	Manual Initiation		

* One Channel (typical of 44 shown on this page)

(1) May be manually bypassed when condenser vacuum is below the trip setpoint in Operational Conditions 2, 3, 4, or 5.

DEFINITIONS FOR
 "CHANNELS", "TRIP SYSTEMS", AND "TRIP FUNCTIONS"
 FOR ISOLATION ACTUATION INSTRUMENTATION TABLE 3.3.2-1 (Continued)
 GROUP 3 ISOLATION (EXCEPT E12-F037A AND B)

Trip Unit	Parameter	Logic			
E31-TS-N608A	RHR Equipment Area #1 ambient temp-high	}			
E31-TS-N610A	RHR Equipment Area #2 ambient temp-high				
E31-TDS-N600A	RHR Equipment Area #1 Δ temp-high				
E31-TDS-N611A	RHR Equipment Area #2 Δ temp-high				
B21-PS-N679A	*Reactor Pressure-high	}	Any One		
B21-PS-N679D	Reactor Pressure-high				
B21-LIS-N680A	RPV Level 3			} Either	Both
B21-HS-M630A	Manual initiation				
B21-LIS-N680D	RPV Level 3			} Either	
B21-HS-M630D	Manual initiation				
			TRIP SYSTEM		
E31-TS-N608B	RHR Equipment Area #1 ambient temp-high	}			
E31-TS-N610B	RHR Equipment Area #2 ambient temp-high				
E31-TDS-N600B	RHR Equipment Area #1 Δ temp-high				
E31-TDS-N611B	RHR Equipment Area #2 Δ temp-high				
B21-PS-N679B	Reactor Pressure-high	}	Any One		
B21-PS-N679C	Reactor Pressure-high				
B21-PS-N680B	RPV Level 3			} Either	Both
B21-HS-M630B	Manual initiation				
B21-LIS-N630C	RPV Level 3			} Either	
B21-HS-M630C	Manual initiation				
			TRIP SYSTEM		
			Close inboard Group 3 valve (E12-F009) TRIP FUNCTION		

* One Channel (typical of 20 shown on this page)

DEFINITIONS FOR
 "CHANNELS", "TRIP SYSTEMS", AND "TRIP FUNCTIONS"
 FOR ISOLATION ACTUATION INSTRUMENTATION TABLE 3.3.2-1 (Continued)
 GROUP 3 ISOLATION (E12-F037A AND B ONLY)

<u>Trip Unit</u>	<u>Parameter</u>	<u>Logic</u>	
E31-TS-N608A	RHR Equipment Area #1 ambient temp-high	}	}
E31-TS-N610A	RHR Equipment Area #2 ambient temp-high		
E31-TD ^c -N600A	RHR Equipment Area #1 Δ temp-high		
E31-TD ^c -N611A	RHR Equipment Area #2 Δ temp-high		
B21-LIS-N680A	*RPV Level 3	} Any One	} Any One
C71-PIS-N650A	Drywell pressure-high		
B21-HS-M630A	Manual initiation	} Both	} TRIP SYSTEM
B21-LIS-N680D	RPV Level 3		
C71-PIS-N650D	Drywell pressure-high	} Any One	} TRIP SYSTEM
B21-HS-M630D	Manual initiation		
E31-TS-N608B	RHR Equipment Area #1 ambient temp-high	}	}
E31-TS-N610B	RHR Equipment Area #2 ambient temp-high		
E31-TDS-N600B	RHR Equipment Area #1 Δ temp-high		
E31-TDS-N611B	RHR Equipment Area #2 Δ temp-high		
B21-LIS-N680B	RPV Level 3	} Any One	} Any One
C71-PIS-N650B	Drywell pressure-high		
B21-HS-M630B	Manual initiation	} Both	} TRIP SYSTEM
B21-LIS-N680C	RPV Level 3		
C71-PIS-N650C	Drywell pressure-high	} Any One	} TRIP SYSTEM
B21-HS-M630C	Manual initiation		

* One Channel (typical of 20 shown on this page)

DEFINITIONS FOR
 "CHANNELS", "TRIP SYSTEMS", AND "TRIP FUNCTIONS"
 FOR ISOLATION ACTION INSTRUMENTATION TABLE 3.3.2-1 (Continued)
 GROUP 4 ISOLATION

Trip Unit	Parameter	Logic	
E31-PDIS-N683A	*RCIC steam line flow-high		Close outboard Group 4 valves TRIP FUNCTION
E31-PIS-N685A	RCIC steam supply pressure-low		
E51-PIS-N655A	RCIC turb exh diaph pressure-high		
E51-PIS-N655E	RCIC turb exh diaph pressure-high		
E31-TS-N602A	RCIC room ambient temp-high		
E31-TDS-N603A	RCIC room Δtemp-high		
E31-TS-N604E	MSL tunnel ambient temp-high		
E31-TDS-N605E	MSL tunnel Δtemp-high		
E31-KIS-R617E	MSL tunnel temp timer		
E31-TS-N608A	RHR Area #1 ambient temp-high		
E31-TS-N610A	RHR Area #2 ambient temp-high		
E31-TDS-N600A	RHR Area #1 Δtemp-high		
E31-TDS-N611A	RHR Area #2 Δtemp-high		
E31-PDIS-N684A	RHR/RCIC steam line flow-high		
E51-HS-M627	Manual initiation (Note k)		
TRIP SYSTEM			
E31-PDIS-N683B	RCIC steam line flow-high		Close inboard Group 4 valves TRIP FUNCTION
E31-PIS-N685B	RCIC steam supply pressure-low		
E51-PIS-N655B	RCIC turb exh diaph pressure-high		
E51-PIS-N655F	RCIC turb exh diaph pressure-high		
E31-TS-N602B	RCIC room ambient temp-high		
E31-TDS-N603B	RCIC room temp-high		
E31-TS-N604F	MSL tunnel ambient temp-high		
E31-TDS-N605F	MSL tunnel Δtemp-high		
E31-KIS-R617F	MSL tunnel temp timer		
E31-TS-N608B	RHR Area #1 ambient temp-high		
E31-TS-N610B	RHR Area #2 ambient temp-high		
E31-TDS-N600B	RHR Area #1 Δtemp-high		
E31-TDS-N611B	RHR Area #2 Δtemp-high		
E31-PDIS-N684B	RHR/RCIC steam line flow-high		
TRIP SYSTEM			

* One Channel (typical of 29 shown on this page)

Note k - A concurrent RCIC initiation signal is required for isolation to occur.

DEFINITIONS FOR
 "CHANNELS", "TRIP SYSTEMS", AND "TRIP FUNCTIONS"
 FOR ISOLATION ACTUATION INSTRUMENTATION TABLE 3.3.2-1 (Continued)
 GROUP 5 ISOLATION

<u>Trip Unit</u>	<u>Parameter</u>			<u>Logic</u>		
B21-LIS-N691A	RPV Level 1	} Either	} Both	TRIP SYSTEM	Close Group 5** valves TRIP FUNCTION	
B21-PIS-N694A	Drywell pressure-high					
B21-LIS-N691E	RPV Level 1	} Either	} Both			
B21-PIS-N694E	Drywell pressure-high					
B21-LIS-N691B *RPV Level 1		} Either	} Both		TRIP SYSTEM	Close Group 5*** valves TRIP FUNCTION
B21-PIS-N694B	Drywell pressure-high					
B21-PIS-N691F	RPV Level 1	} Either	} Both			
B21-PIS-N694F	Drywell pressure-high					

* One Channel (typical of 8 shown on this page)

** The following valves in Group 5 are closed by this trip system:
 E21-F012, E12-F011A, E12-F028A, E12-F024A, E61-F003A, E61-F005A, and E61-F007.

*** The following valves in Group 5 are closed by this trip system:
 E12-F011B, E12-F021, E12-F024B, E12-F028B, E61-F003B, E61-F005B, and E61-F020.

Note: E12-F042A and E12-F042B are closed by Containment Spray System initiation signal.

DEFINITIONS FOR
 "CHANNELS", "TRIP SYSTEMS", AND "TRIP FUNCTIONS"
 FOR ISOLATION ACTUATION INSTRUMENTATION TABLE 3.3.2-1 (Continued)
 GROUP 6A ISOLATION

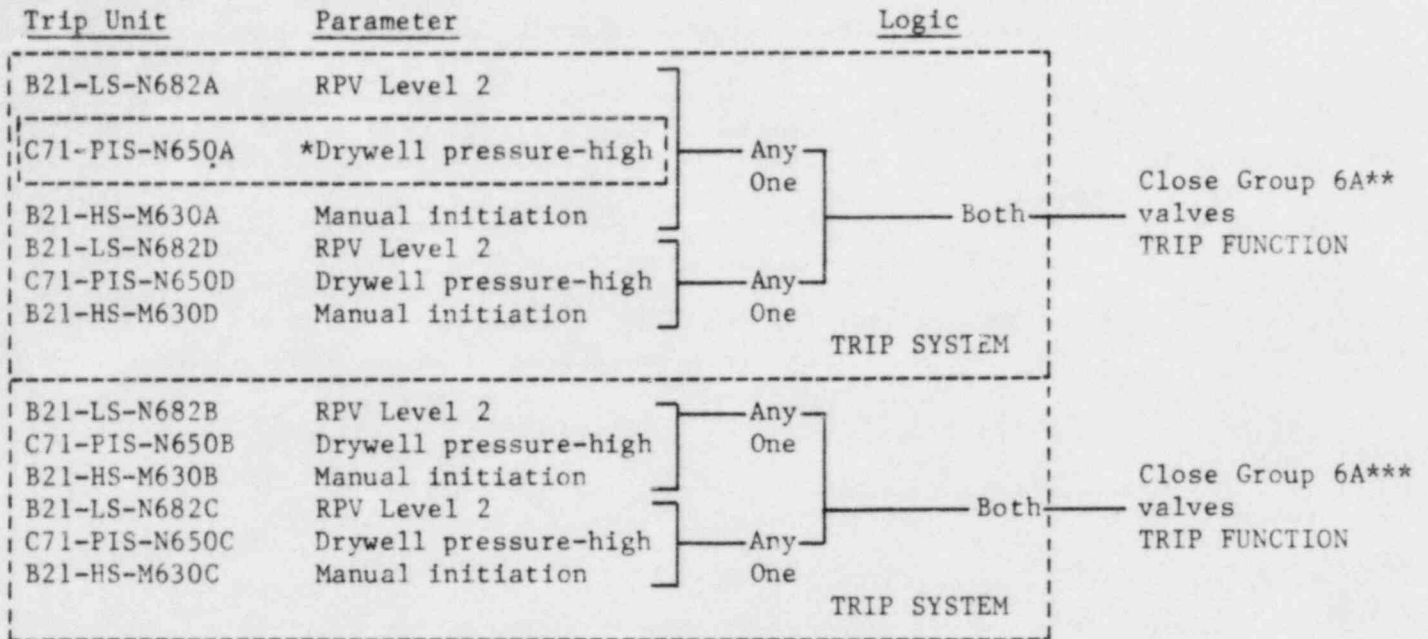

* One Channel (typical of 12 shown on this page)

** The following valves in Group 6A are closed by this trip system:
 P44-F069, P44-F053, P71-F150, P71-F148, P52-F105, P53-F001, G36-F101, P45-F068,
 P45-F062, P11-F075, G41-F028, G41-F029, P45-F273, P11-F130, P53-F003, P45-F099,
 P60-F009, P21-F017, P44-F076, P45-F009, P45-F003, P45-F096.

*** The following valves in Group 6A are closed by this trip system:
 P44-F070, P71-F149, G36-F106, P45-F067, P45-F061, G41-F044, P45-F274, P11-F131,
 P45-F098, P60-F010, P21-F018, P53-F007, P44-F077, P44-F074, P45-F010, P45-F004,
 P52-F195, P45-F097.

DEFINITIONS FOR
 "CHANNELS", "TRIP SYSTEMS", AND "TRIP FUNCTIONS"
 FOR ISOLATION ACTUATION INSTRUMENTATION TABLE 3.3.2-1 (Continued)
 GROUP 7 ISOLATION

<u>Trip Unit</u>	<u>Parameter</u>	<u>Logic</u>		
D17-RITS-K609A	CTMT & drwl vent exh rad hi-hi or downscale	Both	Either Close Group 7** valves TRIP FUNCTION	
D17-RITS-K609D	CTMT & drwl vent exh rad hi-hi or downscale			
B21-LS-N682A	*RPV Level 2	Any One Both		
C71-PIS-N650A	Drywell Pressure-high			
B21-HS-M630A	Manual initiation			
B21-LS-N682D	RPV Level 2			
C71-PIS-N650D	Drywell Pressure-high			
B21-HS-M630D	Manual initiation			
D17-RITS-K609B	CTMT & drwl vent exh rad hi-hi or downscale	Both		Either Close Group 7*** valves TRIP FUNCTION
D17-RITS-K609C	CTMT & drwl vent exh rad hi-hi or downscale			
B21-LS-N682B	RPV Level 2	Any One Both		
C71-PIS-N650B	Drywell Pressure-high			
B21-HS-M630B	Manual initiation			
B21-LS-N682C	RPV Level 2			
C71-PIS-N650C	Drywell Pressure-high			
B21-HS-M630C	Manual initiation			

* One Channel (typical of 16 shown on this page)

** The following valves in Group 7 are closed by this trip system:
 M41-F011, M41-F015, M41-F016, M41-F035, E61-F009, and E61-F057.

*** The following valves in Group 7 are closed by this trip system:
 M41-F012, M41-F013, M41-F017, M41-F034, E61-F010, and E61-F056.

DEFINITIONS FOR
 "CHANNELS", "TRIP SYSTEMS", AND "TRIP FUNCTIONS"
 FOR ISOLATION ACTUATION INSTRUMENTATION TABLE 3.3.2-1 (Continued)
 GROUP 8 ISOLATION

Trip Unit	Parameter	Logic
E31-FS-N609A	RWCU Δ flow-high	Both
E31-KIS-R615A	RWCU Δ flow-timer	
E31-TS-N620A	RWCU area temp-high	Any One
E31-TS-N621A	RWCU area temp-high	
E31-TS-N622A	*RWCU area temp-high	
E31-TS-N623A	RWCU area temp-high	
E31-TS-N624A	RWCU area temp-high	
E31-TS-N625A	RWCU area temp-high	
E31-TS-N626A	RWCU area temp-high	
E31-TS-N627A	RWCU area temp-high	
E31-TDS-N612A	RWCU area Δ temp-high	
E31-TDS-N613A	RWCU area Δ temp-high	
E31-TDS-N614A	RWCU area Δ temp-high	
E31-TDS-N615A	RWCU area Δ temp-high	
E31-TDS-N616A	RWCU area Δ temp-high	
E31-TDS-N617A	RWCU area Δ temp-high	
E31-TDS-N618A	RWCU area Δ temp-high	
E31-TDS-N619A	RWCU area Δ temp-high	
E31-TS-N604A	MSL tunnel temp-high	
E31-TDS-N605A	MSL tunnel Δ temp-high	
C41-HS-M601A	SLCS initiation (Note 1)	
B21-LS-N682A	RPV Level 2	
B21-HS-M630A	Manual initiation	Both
B21-LS-N682D	RPV Level 2	
B21-HS-M630D	Manual initiation	TRIP SYSTEM

Close Group 8**
 valves
 TRIP FUNCTION

* One Channel (typical of 25 shown on this page)

** The following valves in Group 8 are closed by this trip system:
 G33-F034, G33-F039, G33-F004, G33-F054, G33-F252, and G33-F250.

Note 1 - Closes only valve G33-F004

DEFINITIONS FOR
 "CHANNELS", "TRIP SYSTEMS", AND "TRIP FUNCTIONS"
 FOR ISOLATION ACTUATION INSTRUMENTATION TABLE 3-3.2-1 (Continued)
 GROUP 8 ISOLATION (Continued)

<u>Trip Unit</u>	<u>Parameter</u>	<u>Logic</u>	
E31-FS-N609B	RWCU Δ flow-high	Both	
E31-KIS-R615B	RWCU Δ flow-timer		
E31-TS-N620B	RWCU area temp-high		
E31-TS-N621B	RWCU area temp-high		
E31-TS-N622B	*RWCU area temp-high	Any One	Close Group 8*** valves TRIP FUNCTION
E31-TS-N623B	RWCU area temp-high		
E31-TS-N624B	RWCU area temp-high		
E31-TS-N625B	RWCU area temp-high		
E31-TS-N626B	RWCU area temp-high		
E31-TS-N627B	RWCU area temp-high		
E31-TDS-N612B	RWCU area Δ temp-high		
E31-TDS-N613B	RWCU area Δ temp-high		
E31-TDS-N614B	RWCU area Δ temp-high		
E31-TDS-N615B	RWCU area Δ temp-high		
E31-TDS-N616B	RWCU area Δ temp-high		
E31-TDS-N617B	RWCU area Δ temp-high		
E31-TDS-N618B	RWCU area Δ temp-high		
E31-TDS-N619B	RWCU area Δ temp-high		
E31-TS-N604B	MSL tunnel temp-high		
E31-TDS-N605B	MSL tunnel Δ temp-high		
C41-HS-M601B	SLCS initiation (Note 1)	Either	
B21-LS-N682B	RPV Level 2		
B21-HS-M630B	Manual initiation	Either	
B21-LS-N682C	RPV Level 2		
B21-HS-M630C	Manual initiation		

* One Channel (typical of 25 shown on this page)

*** The following valves in Group 8 are closed by this trip system:
 G33-F028, G33-F040, G33-F001, G33-F053, G33-F251, and G33-F253.

Note 1 - Closes only valves G33-F001 & G33-F251

DEFINITIONS FOR
 "CHANNELS", "TRIP SYSTEMS", AND "TRIP FUNCTIONS"
 FOR ISOLATION ACTUATION INSTRUMENTATION TABLE 3.3.2-1 (Continued)
 GROUP 9 ISOLATION

<u>Trip Unit</u>	<u>Parameter</u>	<u>Logic</u>	
E31-PIS-N685A	*RCIC steam supply pressure-low	Both	Close E51-F077 TRIP FUNCTION
B21-PIS-N694A	Drywell pressure-high		
		TRIP SYSTEM	
E31-PIS-N685B	RCIC steam supply pressure-low	Both	Close E51-F078 TRIP FUNCTION
B21-PIS-N694B	Drywell pressure-high		
		TRIP SYSTEM	

* One Channel (typical of 4 shown on this page)

DEFINITIONS FOR
 "CHANNELS", "TRIP SYSTEMS", AND "TRIP FUNCTIONS"
 FOR ISOLATION ACTUATION INSTRUMENTATION TABLE 3.3.2-1 (Continued)
 GROUP 10 ISOLATION

<u>Trip Unit</u>	<u>Parameter</u>	<u>Logic</u>			
B21-LS-N682A	*RPV Level 2	Any One	Both	Close B33-F020 TRIP FUNCTION	
D17-RITS-K610A	MSL radiation-high				
B21-HS-M630A	Manual initiation	Any One	Both		
B21-LS-N682D	RPV Level 2				
D17-RITS-K610D	MSL radiation-high	Any One	Both		
B21-HS-M630D	Manual initiation				
TRIP SYSTEM					
B21-LS-N682B	RPV Level 2	Any One	Both		Close B33-F019 TRIP FUNCTION
D17-RITS-K610B	MSL radiation-high				
B21-HS-M630B	Manual initiation	Any One	Both		
B21-LS-N682C	RPV Level 2				
D17-RITS-K610C	MSL radiation-high	Any One	Both		
B21-HS-M630C	Manual initiation				
TRIP SYSTEM					

* One Channel (typical of 12 shown on this page)

DEFINITIONS FOR
 "CHANNELS", "TRIP SYSTEMS", AND "TRIP FUNCTIONS"
 FOR ISOLATION ACTUATION INSTRUMENTATION TABLE 3.3.2-1 (Continued)

SECONDARY CONTAINMENT ISOLATION

<u>Trip Unit</u>	<u>Parameter</u>	<u>Logic</u>	
C71-PIS-N650A	Drywell Pressure-High		TRIP FUNCTION Note 1
B21-LS-N682A	RPV Level 2		
B21-HS-M630A	Manual Initiation		
C71-PIS-N650D	Drywell Pressure-High		
B21-LS-N682D	*RPV Level 2		TRIP FUNCTION Note 2
B21-HS-M630D	Manual Initiation		
D17-RITS-K617A	Fuel Handling Area Vent. Exh. Rad. Hi-Hi		
D17-RITS-K617D	Fuel Handling Area Vent. Exh. Rad. Hi-Hi		
D17-RITS-K618A	Fuel Handling Area Pool Sweep Exh. Hi-Hi		
D17-RITS-K618D	Fuel Handling Area Pool Sweep Exh. Hi-Hi		
TRIP SYSTEM			

Notes: 1) Closes Containment Cooling System Dampers (M41-F008, M41-F011, M41-F015, M41-F016, M41-F035, and M41-F036), closes Auxiliary Building Fuel Handling Area Ventilation System Inboard Dampers (T42-F004, T42-F011, and T42-F019), closes Auxiliary Building Ventilation System Inboard Damper (T41-F007), starts Standby Gas Treatment System "A", closes Control Room Ventilation System Dampers (Z51-F010, Z51-F003, and Z51-F001) starts Control Room Emergency Filtration System "A" in the isolation mode of operation, and closes secondary containment isolation valves P71-F300, P71-F302, P71-F304, P71-F306, P52-F160A, P52-F221A, P53-F026A, G46-F253, G36-F108, E21-F113, G33-F235, P60-F003, P60-F008, P64-F282A, P64-F283A, P64-F332A, P11-F062, P11-F064, P11-F066, P11-F047, P45-F158, P45-F160, P45-F162, P21-F024, P66-F029A, P44-F121, P44-F122, P44-F117, P44-F118, and E12-F203.

2) Closes Containment Cooling System Auxiliary Building inboard isolation dampers (M41-F008 and M41-F036), closes Auxiliary Building Fuel Handling Area Ventilation System inboard dampers (T42-F004, T42-F011, and T42-F019), closes Auxiliary Building Ventilation System inboard damper (T41-F007) and starts Standby Gas Treatment System "A".

* One Channel (typical of 10 shown on this page)

DEFINITIONS FOR
"CHANNELS", "TRIP SYSTEMS", AND "TRIP FUNCTIONS"
FOR ISOLATION ACTUATION INSTRUMENTATION TABLE 3.3.2-1 (Continued)

SECONDARY CONTAINMENT ISOLATION (Continued)

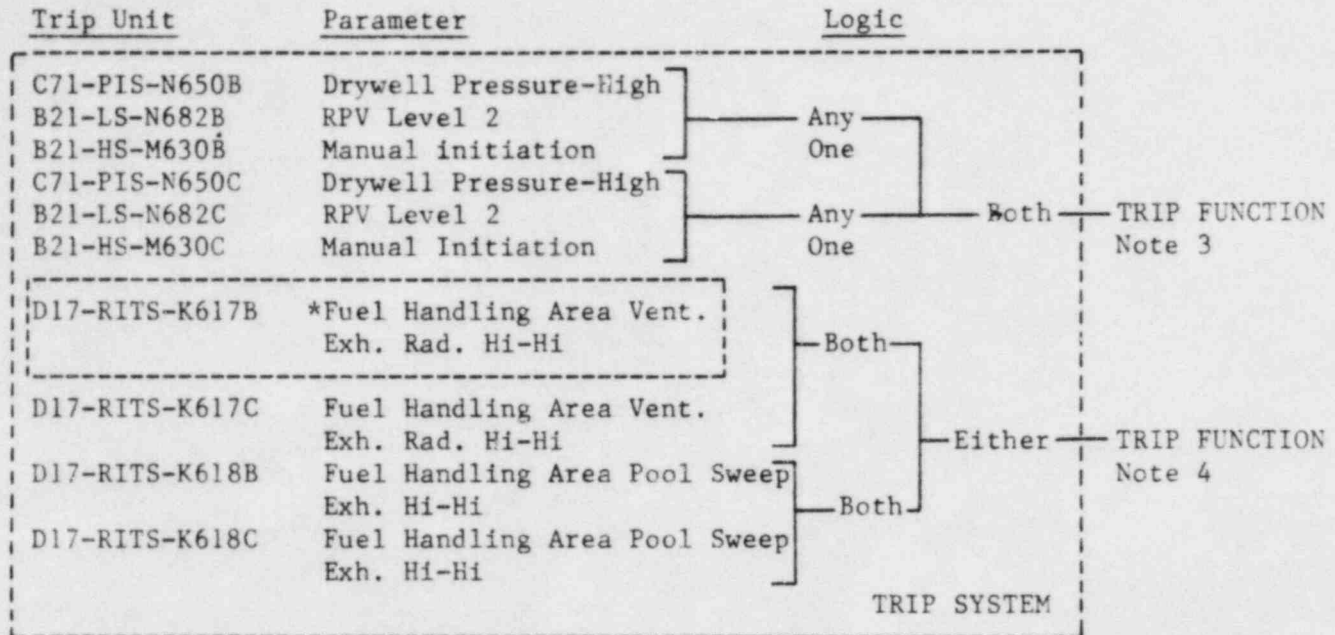

Notes: 3) Closes Containment Cooling System Dampers (M41-F007, M41-F012, M41-F013, M41-F017, M41-F034, and M41-F037), closes Auxiliary Building Fuel Handling Area Ventilation System Outboard Dampers (T42-F003, T42-F012, and T42-F020), Auxiliary Building Ventilation System Outboard Damper (T41-F006), starts Standby Gas Treatment System "B", closes Control Room Ventilation System Dampers (Z51-F011, Z51-F004, and Z51-F002) starts Control Room Emergency Filtration System "B" in the isolation mode of operation, and closes secondary containment isolation valves P71-F301, P71-F303, P71-F305, P71-F307, P52-F160B, P52-F221B, P53-F026B, G46-F253, G36-F109, B21-F114, G33-F234, P60-F004, P60-F007, P64-F282B, P64-F283B, P64-F332B, P11-F063, P11-F065, P11-F067, P11-F061, P45-F159, P45-F161, P21-F024, P66-F029A, P44-F116, P44-F119, P44-F120, P44-F123, and E12-F203.

4) Closes Containment Cooling System outboard isolation dampers (M41-F007 and M41-F037), closes Auxiliary Building Fuel Handling Area Ventilation System outboard dampers (T42-F003, T42-F012, and T42-F020), closes Auxiliary Building Ventilation System outboard damper (T41-F006) and starts Standby Gas Treatment System "B".

* One Channel (Typical of 10 shown on this page)

DEFINITIONS FOR
 "CHANNELS", "TRIP SYSTEMS", AND "TRIP FUNCTIONS"
 FOR EMERGENCY CORE COOLING SYSTEM ACTUATION INSTRUMENTATION TABLE 3.3.3-1

RHR and LPCS Trip Systems

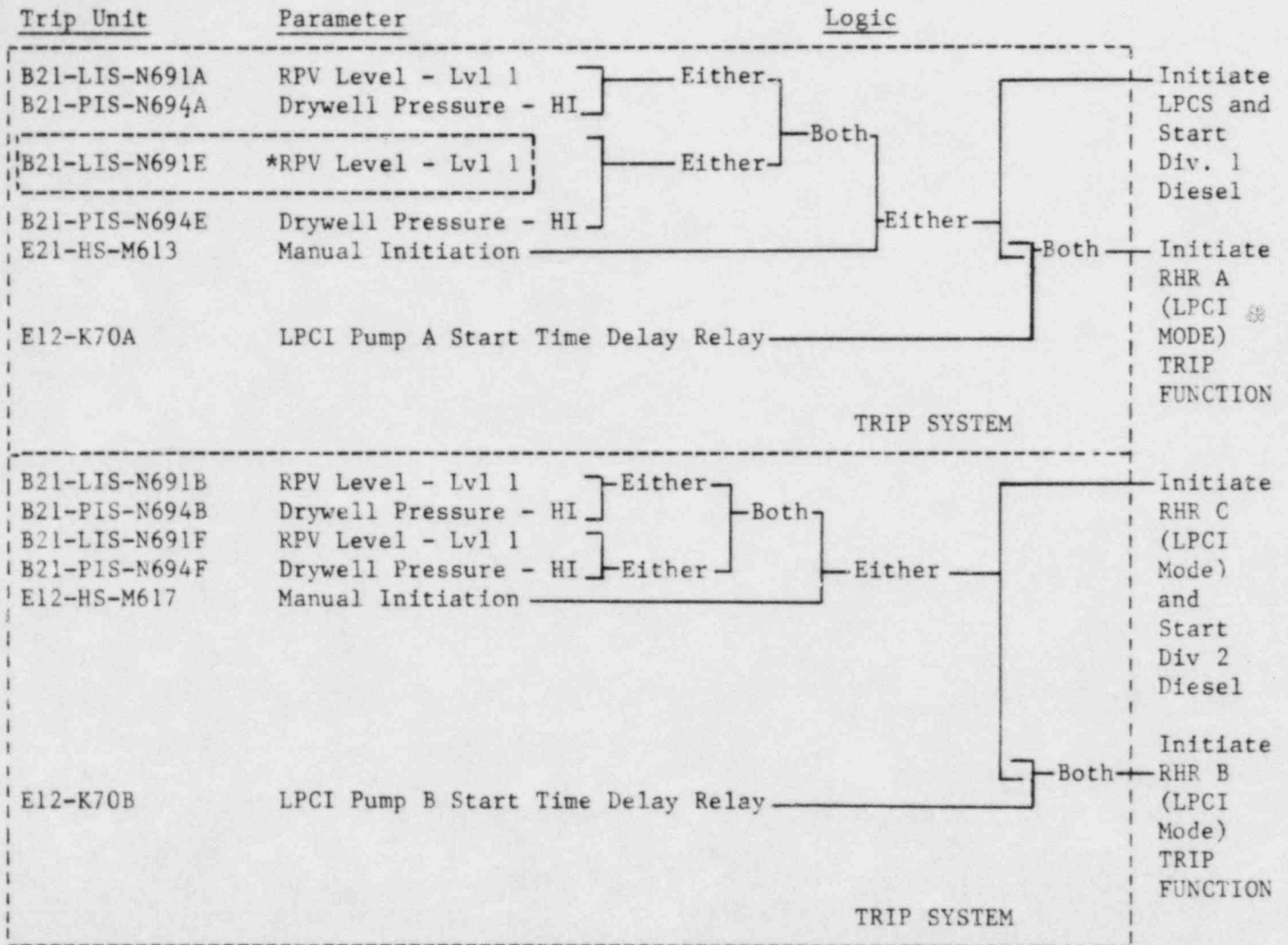

* One Channel (typical of 12 shown on this page)

DEFINITIONS FOR
 "CHANNELS", "TRIP SYSTEMS", AND "TRIP FUNCTIONS"
 FOR EMERGENCY CORE COOLING SYSTEM ACTUATION INSTRUMENTATION TABLE 3.3.3-1 (Continued)

ADS Trip Systems
 ADS "A"

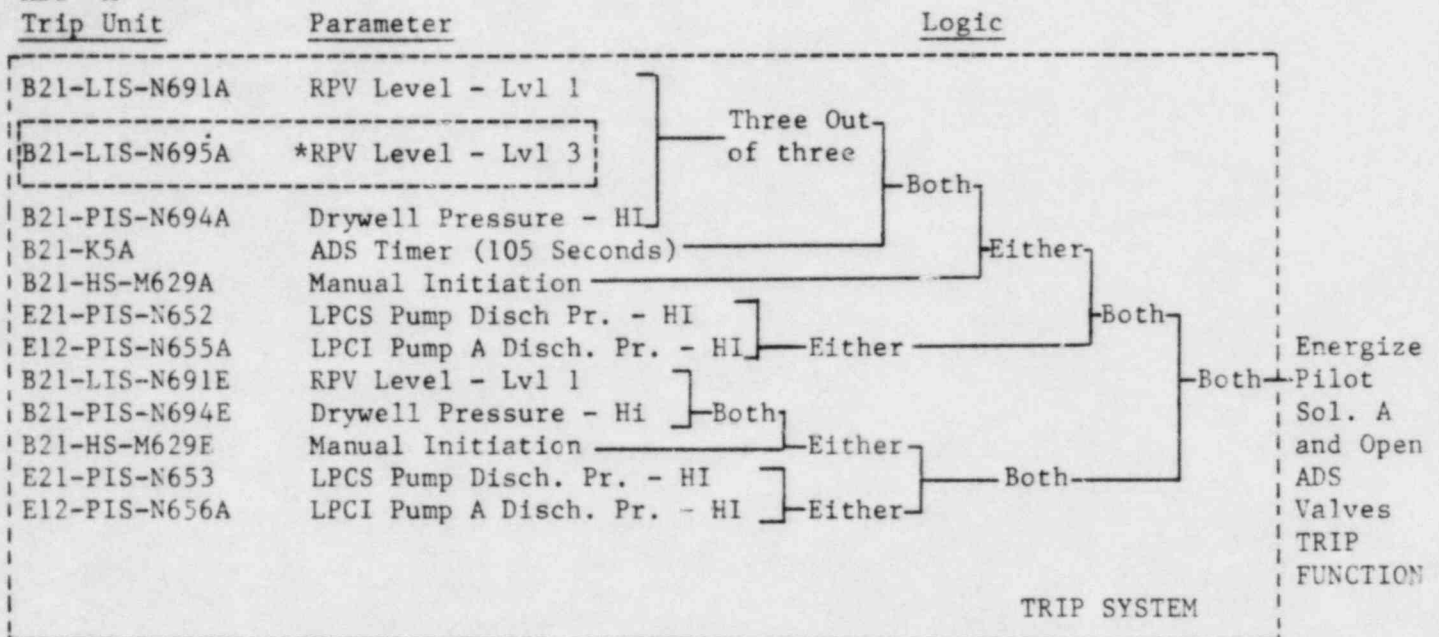

* One Channel (Typical of 12 shown on this page)

DEFINITIONS FOR
 "CHANNELS", "TRIP SYSTEMS", AND "TRIP FUNCTIONS"
 FOR EMERGENCY CORE COOLING SYSTEM ACTUATION INSTRUMENTATION TABLE 3.3.3-1 (Continued)

ADS "B"

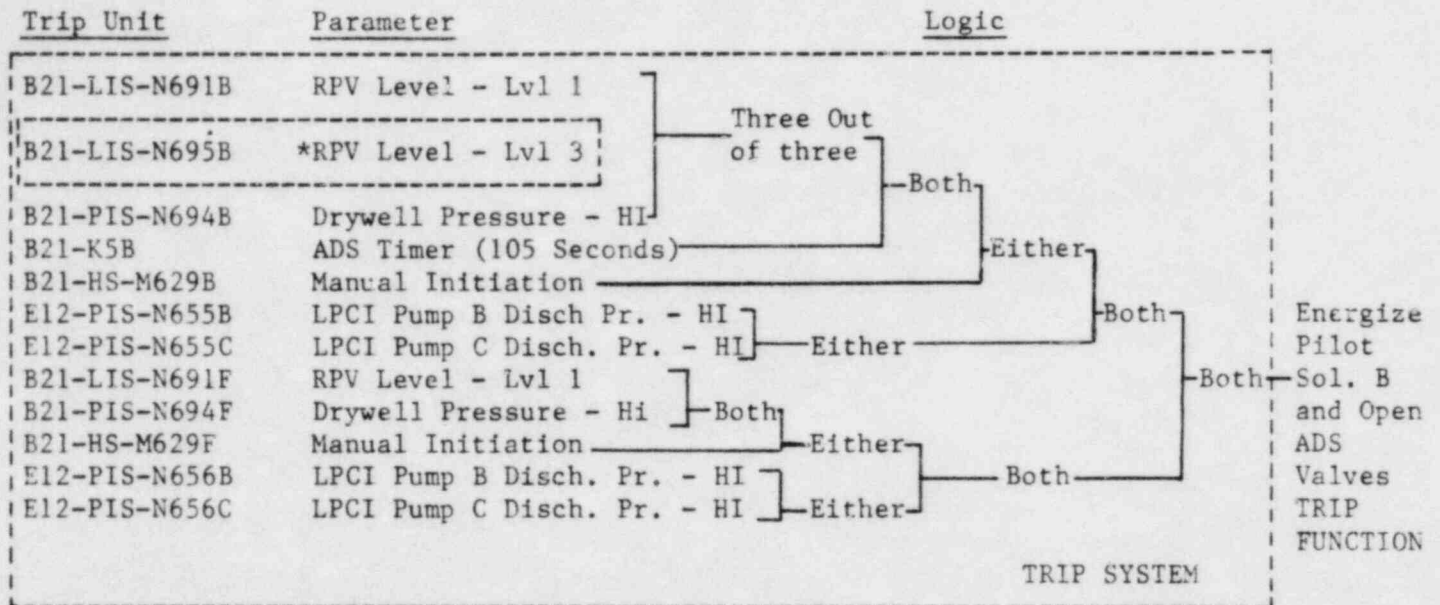

* One Channel (Typical of 12 shown for ADS "B")

HPCS System

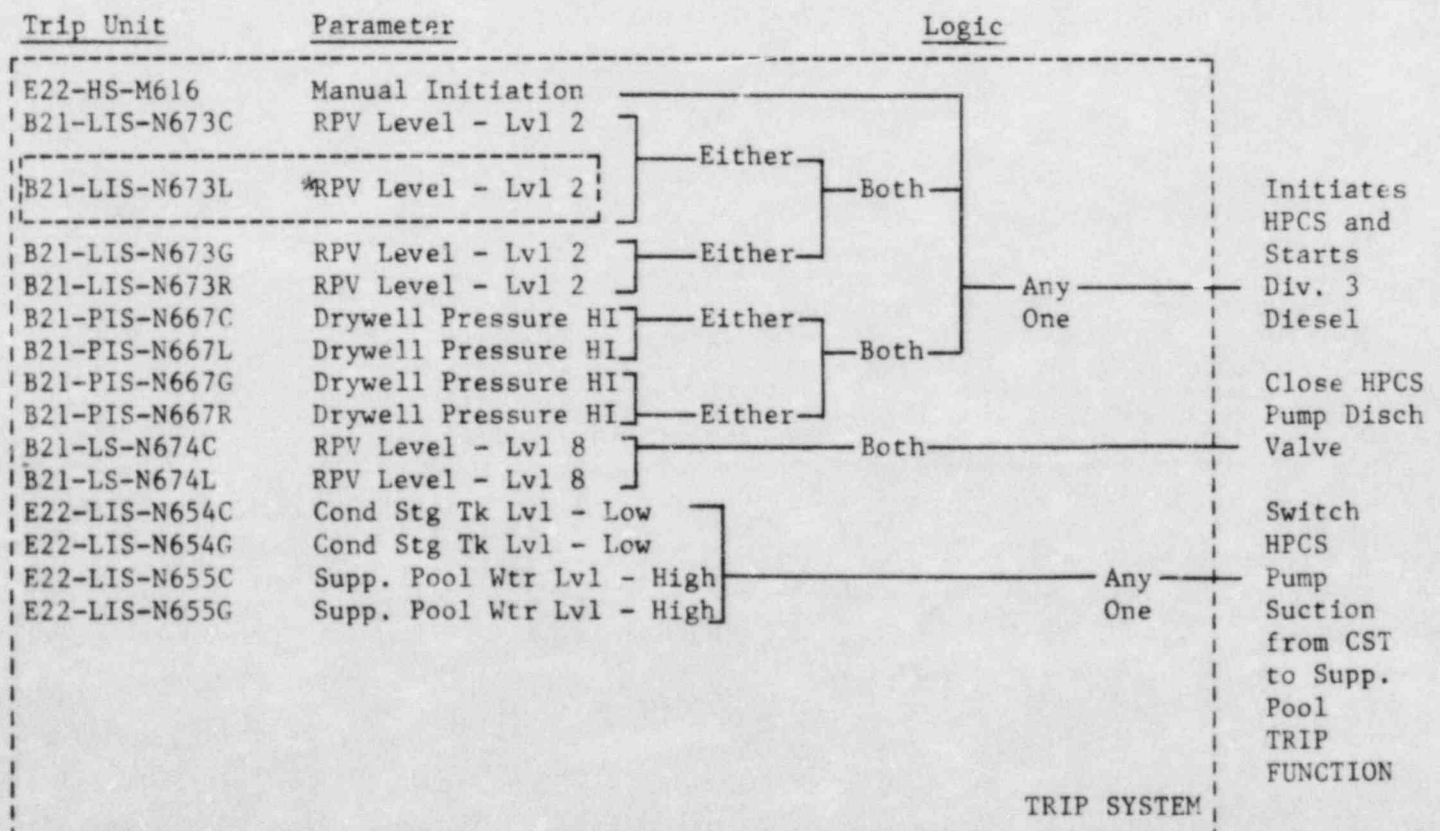

* One Channel (Typical of 15 shown for HPCS)
 L1sd23

DEFINITIONS FOR
 "CHANNELS", "TRIP SYSTEMS", AND "TRIP FUNCTIONS"
 FOR EMERGENCY CORE COOLING SYSTEM ACTUATION
 INSTRUMENTATION TABLE 3.3.3-1 (Continued)

Loss of Power
 Division 1 (1H13-P331)

<u>Trip Unit</u>	<u>Parameter</u>	<u>Logic</u>	
Bistable XA3	4.16 KV Bus Undervoltage (Loss of Voltage 70%)	Either—XA22 TD-1 Timer Both Either—XA22 TD-2 Timer TRIP SYSTEM	Initiates Load Shedding, Trips Incoming Breakers, and Starts Div. 1 Diesel TRIP FUNCTION
Bistable XA11	4.16 KV Bus Undervoltage (Loss of Voltage 70%)		
Bistable XA19	4.16 KV Bus Undervoltage (Loss of Voltage 70%)		
Bistable XA27	4.16 KV Bus Undervoltage (Loss of Voltage 70%)		
Bistable XA4	4.16 KV Bus Undervoltage (BOP Load Shed 80%)	Either—XA30 TD-3 Timer Both Either—XA30 TD-2 Timer TRIP SYSTEM	With Concurrent LOCA Signal, Initiates Trip of Incoming Breakers to 4.16KV & 6.9 KV BOP Busses TRIP FUNCTION
Bistable XA12	4.16 KV Bus Undervoltage (BOP Load Shed 80%)		
Bistable XA20	4.16 KV Bus Undervoltage (BOP Load Shed 80%)		
Bistable XA28	*4.16 KV Bus Undervoltage (BOP Load Shed 80%)		
Bistable XA5	4.16 KV Bus Undervoltage (Degraded Voltage 90%)	Either—XA23 TD-1 Timer Both Either—XA23 TD-2 Timer TRIP SYSTEM	Trips Incoming Breakers TRIP FUNCTION
Bistable XA13	4.16 KV Bus Undervoltage (Degraded Voltage 90%)		
Bistable XA21	4.16 KV Bus Undervoltage (Degraded Voltage 90%)		
Bistable XA29	4.16 KV Bus Undervoltage (Degraded Voltage 90%)		

* One Channel (Typical of 12 shown on this page)

NOTE: Each timer is part of two undervoltage channels. 70% undervoltage trip occurs due to trip of incoming breakers after 90% undervoltage trip.

DEFINITIONS FOR
 "CHANNELS", "TRIP SYSTEMS", AND "TRIP FUNCTIONS"
 FOR EMERGENCY CORE COOLING SYSTEM ACTUATION
 INSTRUMENTATION TABLE 3.3.3-1 (Continued)

Loss of Power

Division 2 (1H13-P332)

<u>Trip Unit</u>	<u>Parameter</u>	<u>Logic</u>	
Bistable XA3	4.16 KV Bus Undervoltage (Loss of Voltage 70%)	Either—XA22 TD-1 Timer Both Either—XA22 TD-2 Timer TRIP SYSTEM	Initiates Load Shedding, Trips Incoming Breakers, and Starts Div. 2 Diesel TRIP FUNCTION
Bistable XA11	4.16 KV Bus Undervoltage (Loss of Voltage 70%)		
Bistable XA19	4.16 KV Bus Undervoltage (Loss of Voltage 70%)		
Bistable XA27	4.16 KV Bus Undervoltage (Loss of Voltage 70%)		
Bistable XA4	4.16 KV Bus Undervoltage (BOP Load Shed 80%)	Either—XA30 TD-3 Timer Both Either—XA30 TD-2 Timer TRIP SYSTEM	With Concurrent LOCA Signal, Initiates Trip of Incoming Breakers to 4.16KV & 6.9 KV BOP Busses TRIP FUNCTION
Bistable XA12	4.16 KV Bus Undervoltage (BOP Load Shed 80%)		
Bistable XA20	4.16 KV Bus Undervoltage (BOP Load Shed 80%)		
Bistable XA28	*4.16 KV Bus Undervoltage (BOP Load Shed 80%)		
Bistable XA5	4.16 KV Bus Undervoltage (Degraded Voltage 90%)	Either—XA23 TD-1 Timer Both Either—XA23 TD-2 Timer TRIP SYSTEM	Trips Incoming Breakers TRIP FUNCTION
Bistable XA13	4.16 KV Bus Undervoltage (Degraded Voltage 90%)		
Bistable XA21	4.16 KV Bus Undervoltage (Degraded Voltage 90%)		
Bistable XA29	4.16 KV Bus Undervoltage (Degraded Voltage 90%)		

* One Channel (Typical of 12 shown on this page)

NOTE: Each timer is part of two undervoltage channels. 70% undervoltage trip occurs due to trip of incoming breakers after 90% undervoltage trip.

DEFINITIONS FOR
"CHANNELS", "TRIP SYSTEMS", AND "TRIP FUNCTIONS"
FOR EMERGENCY CORE COOLING SYSTEM ACTUATION
INSTRUMENTATION TABLE 3.3.3-1 (Continued)

Loss of Power

Division 3 (Diesel Gen. Initiation)

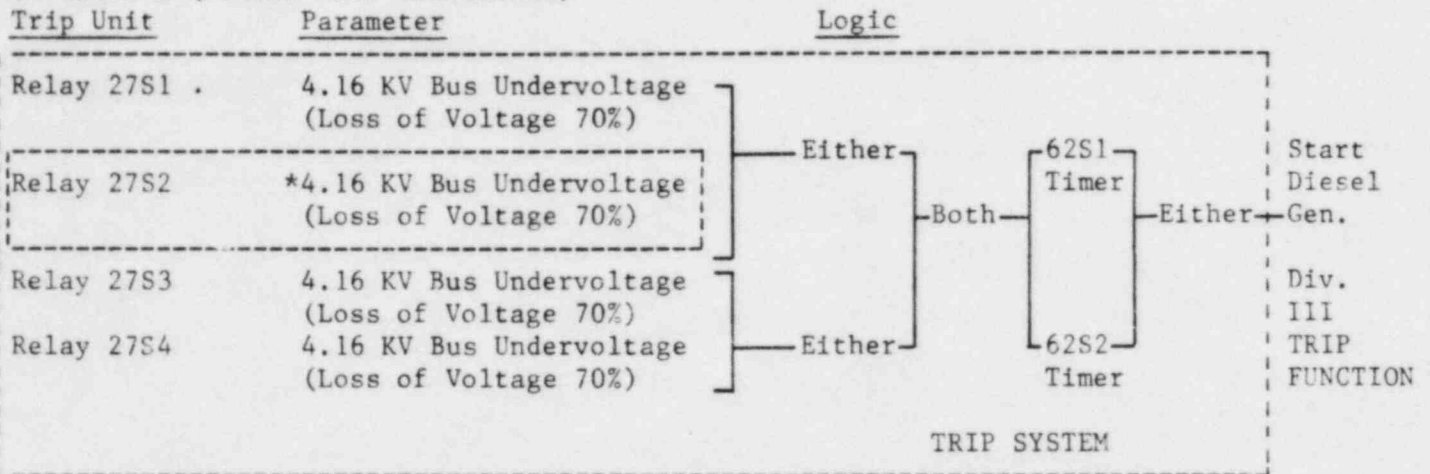

* One Channel (typical of 4 shown for Loss of Power Div. 3 Diesel Gen Initiation)

Loss of Power

Division 3 (Trip of Incoming Breakers)

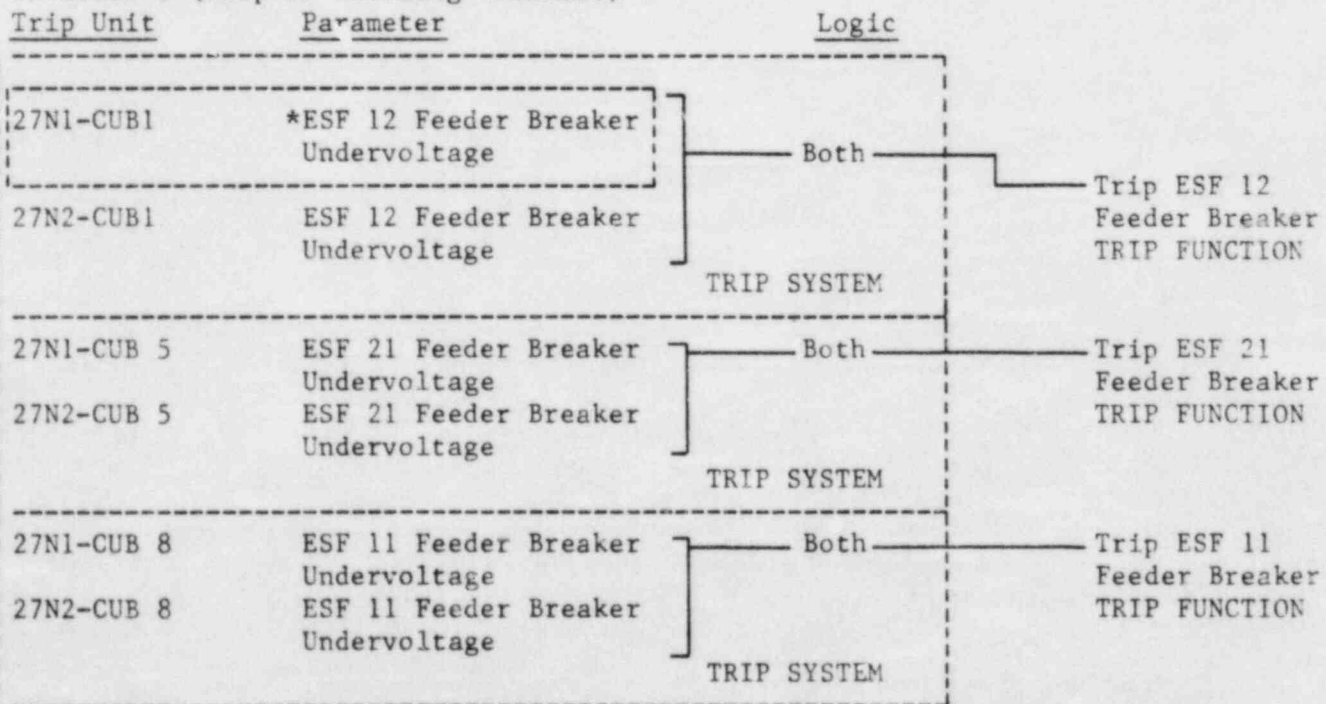

* One Channel (Typical of 6 shown for Loss of Power Div. 3 Trip of Incoming Breaker)

NOTE: Channel operability requirements for the above channels are not listed in the Technical Specifications. This page is intended to clarify the difference between the Division 3 Diesel start logic and the feeder breaker trip logic.

DEFINITIONS FOR
 "CHANNELS", "TRIP SYSTEMS", AND "TRIP FUNCTIONS"
 FOR ATWS RECIRCULATION PUMP TRIP SYSTEM INSTRUMENTATION TABLE 3.3.4.1-1

<u>Trip Unit</u>	<u>Parameter</u>	<u>Logic</u>	
B21-LIS-N699A	RPV Level - Lvl 2	} ————— Either —————	Trip Pump C001A
B21-PIS-N658A	*RPV Press - HI		
B21-LIS-N699B	RPV Level - Lvl 2	} ————— Either —————	Trip Pump C001B
B21-PIS-N658B	RPV Press - HI		
TRIP SYSTEM			TRIP FUNCTION
B21-LIS-N699E	RPV Level - Lvl 2	} ————— Either —————	Trip Pump C001A
B21-PIS-N658E	RPV Press - HI		
B21-LIS-N699F	RPV Level - Lvl 2	} ————— Either —————	Trip Pump C001B
B21-PIS-N658F	RPV Press - HI		
TRIP SYSTEM			TRIP FUNCTION

* One Channel (Typical of 8 shown on this page)

DEFINITIONS FOR
 "CHANNELS", "TRIP SYSTEMS", AND "TRIP FUNCTIONS"
 FOR END-OF-CYCLE RECIRCULATION PUMP TRIP SYSTEM
 INSTRUMENTATION TABLE 3.3.4.2-1

<u>Trip Unit</u>	<u>Parameter</u>	<u>Logic</u>	
C71-PIS-N605A	Turbine Control Vlv-Fast Closure	Both	RPT System A TRIP FUNCTION(1)
C71-PIS-N605B	Turbine Control Vlv-Fast Closure		
C71-PIS-N606A	Turbine Stop Vlv Closure	Both	
C71-PIS-N606D	*Turbine Stop Vlv Closure		
TRIP SYSTEM			
C71-PIS-N605C	Turbine Control Vlv-Fast Closure	Both	RPT System B TRIP FUNCTION(1)
C71-PIS-N605D	Turbine Control Vlv-Fast Closure		
C71-PIS-N606F	Turbine Stop Vlv Closure	Both	
C71-PIS-N606G	Turbine Stop Vlv Closure		
TRIP SYSTEM			

* One Channel (Typical of 8 shown on this page)

(1) This function is automatically bypassed when turbine first stage pressure is less than 30 % of the value of turbine first stage pressure, in psia, at valves wide open (VWO) steam flow, equivalent to thermal power less than 40% of rated thermal power.

DEFINITIONS FOR
 "CHANNELS", "TRIP SYSTEMS", AND "TRIP FUNCTIONS"
 FOR REACTOR CORE ISOLATION COOLING SYSTEM ACTUATION
 INSTRUMENTATION TABLE 3.3.5-1

Trip Unit	Parameter	Logic	
B21-LS-N692E	RPV Level - Lvl 2	} Either	}
B21-LS-N692B	*RPV Level - Lvl 2		
B21-LS-N692A	RPV Level - Lvl 2	} Either	} Either
B21-LS-N692F	RPV Level - Lvl 2		
E51-HS-M625	Manual Initiation		One
B21-LS-N693A	RPV Level High - Lvl 8	} Both	} Both
B21-LS-N693B	RPV Level High - Lvl 8		
E51-LIS-N635A	Condensate Stg Tank Level Lo	} Any	} Any
E51-LIS-N635E	Condensate Stg Tank Level Lo		
E51-LIS-N636A	Suppression Pool Wtr Lvl Hi	} One	} One
E51-LIS-N636E	Suppression Pool Wtr Lvl Hi		
			Close
			E51-F045
			Switch
			Pump
			Suction to
			Suppres-
			sion Pool
			TRIP
			FUNCTION
			TRIP SYSTEM

* One Channel (Typical of 11 shown on this page)

DEFINITIONS FOR
 "CHANNELS", "TRIP SYSTEMS", AND "TRIP FUNCTIONS"
 FOR CONTROL ROD BLOCK INSTRUMENTATION TABLE 3.3.6-1

<u>Trip Unit/Card</u>	<u>Parameter</u>	<u>Logic</u>
C51-K600A(B)	SRM-Detector Not Full In (1) (5)	} Any Nu One
C51-K600E(F)	SRM-Detector Not Full In (1) (5)	
C51-K600D(C)	SRM-Detector Not Full In (1) (5)	
C51-K600A(B)	*SRM-Upscale (2) (5)	
C51-K600E(F)	SRM-Upscale (2) (5)	
C51-K600D(C)	SRM-Upscale (2) (5)	
C51-K600A(B)	SRM-Inoperative (2) (5)	
C51-K600E(F)	SRM-Inoperative (2) (5)	
C51-K600D(C)	SRM-Inoperative (2) (5)	
C51-K600A(B)	SRM-Downscale (3) (5)	
C51-K600E(F)	SRM-Downscale (3) (5)	
C51-K600D(C)	SRM-Downscale (3) (5)	
C51-K601D(B)	IRM-Detector Not Full In (4) (6)	
C51-K601H(F)	IRM-Detector Not Full In (4) (6)	
C51-K601A(C)	IRM-Detector Not Full In (4) (6)	
C51-K601E(G)	IRM-Detector Not Full In (4) (6)	
C51-K601D(B)	IRM-Upscale (6)	
C51-K601H(F)	IRM-Upscale (6)	
C51-K601A(C)	IRM-Upscale (6)	
C51-K601E(G)	IRM-Upscale (6)	
C51-K601D(B)	IRM-Inoperative (6)	
C51-K601H(F)	IRM-Inoperative (6)	
C51-K601A(C)	IRM-Inoperative (6)	
C51-K601E(G)	IRM-Inoperative (6)	
C51-K601D(B)	IRM-Downscale (4) (6)	
C51-K601H(F)	IRM-Downscale (4) (6)	
C51-K601A(C)	IRM-Downscale (4) (6)	
C51-K601E(G)	IRM-Downscale (4) (6)	
C51-Z401A(B)	APRM-Inoperative (6)	} Any Npu One
C51-Z401E(F)	APRM-Inoperative (6)	
C51-Z401D(C)	APRM-Inoperative (6)	
C51-Z401H(G)	APRM-Inoperative (6)	
C51-Z405A(B)	APRM-Neutron Flux - Upscale, Startup (6)	
C51-Z405E(F)	APRM-Neutron Flux - Upscale, Startup (6)	
C51-Z405D(C)	APRM-Neutron Flux - Upscale, Startup (6)	
C51-Z405H(G)	APRM-Neutron Flux - Upscale, Startup (6)	
C51-Z409A(B)	APRM-Flow Biased Neutron Flux - Upscale (6)	
C51-Z409E(F)	APRM-Flow Biased Neutron Flux - Upscale (6)	
C51-Z409D(C)	APRM-Flow Biased Neutron Flux - Upscale (6)	
C51-Z409H(G)	APRM-Flow Biased Neutron Flux - Upscale (6)	

* Two Channels (C51-K600A and C51-K600B are separate channels) total of 80 channels shown on this page

DEFINITIONS FOR
 "CHANNELS", "TRIP SYSTEMS", AND "TRIP FUNCTIONS"
 FOR CONTROL ROD BLOCK INSTRUMENTATION TABLE 3.3.6-1 (Continued)

<u>Trip Unit/Card</u>	<u>Parameter</u>	<u>Logic</u>	
C51-Z423A(B)	APRM-Downscale (6)	}	
C51-Z423E(F)	APRM-Downscale (6)		
C51-Z423D(C)	APRM-Downscale (6)		
C51-Z423H(G)	*APRM-Downscale (6)		
C51-Z118A(B)	Reactor Recirc Flow-Upscale (7)	} ————— Any ————— Npd	
C51-Z118E(F)	Reactor Recirc Flow-Upscale (7)		
C51-Z118D(C)	Reactor Recirc Flow-Upscale (7)		
C51-Z118H(G)	Reactor Recirc Flow-Upscale (7)		
C11-N602A(B)	Scram Disch Volume - High		One ————— SDV
C11-N654A(B)	RPCS Low Power Setpoint	} ————— Either ————— Ww ————— RPCS	
C11-N654C(D)	RPCS Intermediate Rod Withdrawal		One ————— Interlock
	Limiter Setpoint		

* Two channels (C51-Z423H and C51-Z423G are separate channels) total of 22 channels shown on this page.

NOTES:

- (1) Automatically bypassed if count rate greater than 100 cps or IRM's on range three or above.
- (2) Automatically bypassed when associated IRM channels are on range eight or above.
- (3) Automatically bypassed when IRM channels are on Range three or above.
- (4) Automatically bypassed when the IRM channels are on range 1. (IRM full-in bypass is not included in Grand Gulf IRM design.)
- (5) Two of the six channels may be bypassed without taking the Technical Specification ACTION.
- (6) Two of the eight channels may be bypassed without taking the Technical Specification ACTION.
- (7) Total of 3 channels required to be operable.

DEFINITIONS FOR
 "CHANNELS", "TRIP SYSTEMS", AND "TRIP FUNCTIONS"
 FOR CONTROL ROD BLOCK INSTRUMENTATION TABLE 3.3.6-1 (Continued)

Rod Withdrawal Block Shown in Relation to Reactor Mode Switch Position

Using the parameters already defined (Nu, Npu, Npd, SDV, and Ww) along with those defined below, the equation for Rod Withdrawal Block is shown below in relation to reactor mode switch position.

Rx Mode Switch in Run

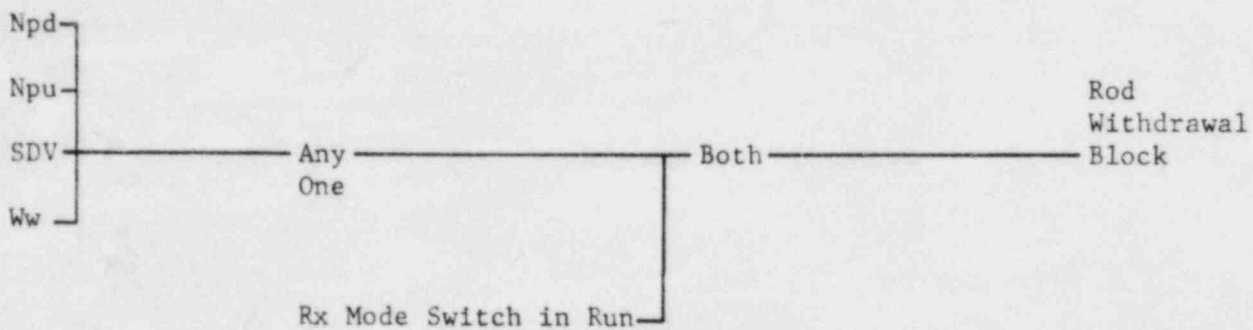

Rx Mode Switch in Startup

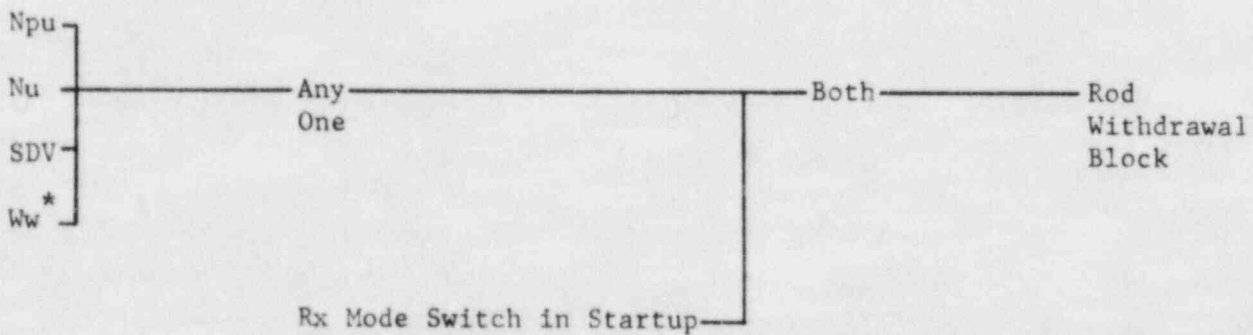

* Ww - RPCS performs Rod Sequence control function when less than or equal to 20 +15,-0% thermal power.

DEFINITIONS FOR
"CHANNELS", "TRIP SYSTEMS", AND "TRIP FUNCTIONS"
FOR CONTROL ROD BLOCK INSTRUMENTATION TABLE 3.3.6-1 (Continued)

Rx Mode Swith in Refuel

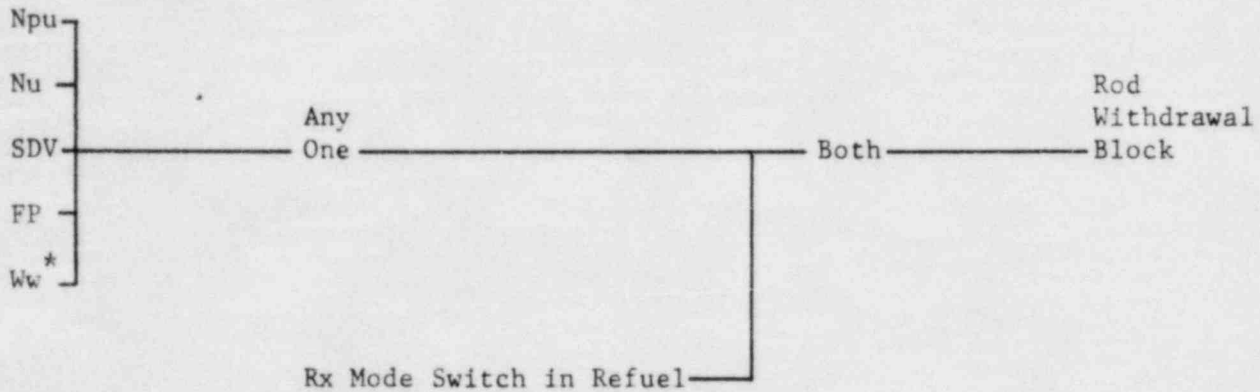

Where FP = Refueling Equipment Rod Block Inputs **

* Ww - If RPCS is not in operation, a rod block is initiated. This is the only rod block input from RPCS in refuel.

** The refueling equipment rod blocks are verified operable in Technical Specification 3/4.9.1.

DEFINITIONS FOR
 "CHANNELS", "TRIP SYSTEMS", AND "TRIP FUNCTIONS"
 FOR RADIATION MONITORING INSTRUMENTATION TABLE 3.3.7.1-1

<u>Trip Unit/ Monitor</u>	<u>Parameter</u>	<u>Logic/ Function</u>
D17-RITS-K607	Comp. Clg. Wtr.	Hi Alarm/Monitor
D17-RITS-K604	SSW Loop A	Hi Alarm/Monitor
D17-RITS-K605	*SSW Loop B	Hi Alarm/Monitor
D17-RITS-K612	Offgas Pre-treatment	Hi Alarm/Monitor
<u>Offgas-Post Treatment</u>		
D17-RITS-K601A	Hi, Hi-Hi-Hi Hi-Hi-Hi or Downscale	Hi, or Hi-Hi-Hi, Alarm/Monitor
D17-RITS-K601B	Hi-Hi-Hi or Downscale Hi, Hi-Hi-Hi	Closes Offgas Disch. N64-F060 TRIP FUNCTION
		Both
		Hi, or Hi-Hi-Hi, Alarm/Monitor
TRIP SYSTEM		
D17-RITS-K611	Carbon Bed Vault	Hi Alarm/Monitor
<u>Control Room Ventilation</u>		
D17-RITS-K621A	Hi Hi-Hi or Downscale	Hi Alarm/Monitor
D17-RITS-K621D	Hi-Hi or Downscale Hi	Isolates CR and Starts CR Fresh Air Unit A TRIP FUNCTION
		Both
		Hi Alarm/Monitor
TRIP SYSTEM		

* One Channel (Typical of 9 shown on this page)

DEFINITIONS FOR
 "CHANNELS", "TRIP SYSTEMS", AND "TRIP FUNCTIONS"
 FOR RADIATION MONITORING INSTRUMENTATION TABLE 3.3.7.1-1 (Continued)

<u>Trip Unit/ Monitor</u>	<u>Parameter</u>	<u>Logic Function</u>
Control Room Ventilation		
D17-RITS-K621B	Hi	Hi Alarm/Monitor
	Hi-Hi or Downscale	
		Isolates CR and Starts CR Fresh Air Unit B TRIP FUNCTION
	Both	
D17-RITS-K621C	Hi-Hi or Downscale	Hi Alarm/Monitor
	Hi	
TRIP SYSTEM		
D17-RITS-K609A	Containment & DW Vent. Exh. (1)	Hi Alarm/Monitor
D17-RITS-K609B	Containment & DW Vent. Exh. (1)	Hi Alarm/Monitor
D17-RITS-K609C	Containment & DW Vent. Exh. (1)	Hi Alarm/Monitor
D17-RITS-K609D	Containment & DW Vent. Exh. (1)	Hi Alarm/Monitor
D17-RITS-K617A	Fuel Handling Area Vent. (1)	Hi Alarm/Monitor
D17-RITS-K617B	*Fuel Handling Area Vent. (1)	Hi Alarm/Monitor
D17-RITS-K617C	Fuel Handling Area Vent (1)	Hi Alarm/Monitor
D17-RITS-K617D	Fuel Handling Area Vent (1)	Hi Alarm/Monitor
D17-RITS-K618A	Fuel Handling Area Pool Sweep Exh (1)	Hi Alarm/Monitor
D17-RITS-K618B	Fuel Handling Area Pool Sweep Exh (1)	Hi Alarm/Monitor
D17-RITS-K618C	Fuel Handling Area Pool Sweep Exh (1)	Hi Alarm/Monitor
D17-RITS-K618D	Fuel Handling Area Pool Sweep Exh (1)	Hi Alarm/Monitor
D21-RITS-K622**	New Fuel Storage Vault	Hi Alarm/Monitor
D21-RITS-K623**	New Fuel Storage Vault	Hi Alarm/Monitor
D21-RITS-K624***	Spent Fuel Storage Pool	Hi Alarm/Monitor
D21-RITS-K625***	Spent Fuel Storage Pool	Hi Alarm/Monitor
D21-RITS-K626	Dryer Storage Area	Hi Alarm/Monitor
D21-RITS-K600	Control Room Rad. Monitor	Hi Alarm/Monitor

* One channel (Typical of 20 shown on this page)

** Only (1) of the New Fuel Storage Vault radiation monitors is required operable.

*** Only (1) of the Spent Fuel Storage Pool radiation monitors is required operable.

(1) Logics, Trip Systems, and Trip Functions are shown on Isolation Acutation Instrumentation Table 3.3.2-1

DEFINITIONS FOR
 "CHANNELS", "TRIP SYSTEMS", AND "TRIP FUNCTIONS"
 FOR SEISMIC MONITORING INSTRUMENTATION TABLE 3.3.7.2-1

<u>Monitor/ Recorder</u>	<u>Parameter</u>	<u>Function</u>
<u>Triaxial Strong Motion Accelerometer (SMA)</u>		
C85-XR-R601	Containment Foundation] Records Seismic Event in Respective Locations
C85-XR-R602	*Drywell	
C85-XR-R603	SGTS Filter Train	
C85-XR-R604	SSW Pump House A	
C85-XR-R605	Free Field	
<u>Triaxial Peak Recording Accelerograph (PRA)</u>		
C85-XR-R005A	Containment Dome] Records Seismic Event in Respective Locations
C85-XR-R006A	Aux Building Foundation	
C85-XR-R007A	Diesel Generator 11	
C85-XR-R008	Control Building Foundation	
C85-XR-R600	Control Room	
C85-XR-R010	Reactor Vessel Support	
C85-XR-R011	Reactor Recirc Piping	
C85-XR-R012	Main Steam Piping	
C85-XR-R013	LPCS Spray Line	
C85-XR-R014	HPCS Spray Line	
C85-XR-R004	SSW Pump House B	
<u>Seismic Switches</u>		
C85-XS-N008 (SSE)	Containment Foundation] Measures Seismic Activity and Produces CR Annunciation
C85-XS-N009 (OBE)	Containment Foundation	
C85-XS-N010 (SSE)	Drywell	
C85-XS-N011 (OBE)	Drywell	
<u>Seismic Triggers</u>		
C85-XS-N006	Containment Foundation] Starts SMA Recording System & Produces CR Annunciation
C85-XS-N007	Drywell	

* One Channel (Typical of 22 shown on this page)

NOTE: Seismic Triggers C85-XS-N006 and C85-XS-N007 Start SMA Recorder C85-XS-R601 through C85-XR-R605 and Produce Control Room Annunciation.

DEFINITIONS FOR
 "CHANNELS", "TRIP SYSTEMS", AND "TRIP FUNCTIONS"
 FOR METEOROLOGICAL MONITORING INSTRUMENTATION,
 TABLE 3.3.7.3-1

<u>Instrument</u>	<u>Parameter</u>	<u>Function</u>
SC84-SE-N001A(B)	Wind Speed 162 ft.	Indication Only
SC84-SE-N004A(B)	Wind Speed 33 ft.	Indication Only
SC84-ZE-N002A(B)	*Wind Direction 162 ft.	Indication Only
SC84-ZE-N005A(B)	Wind Direction 33 ft.	Indication Only
SC84-TE-N006A(B)	Air Temperature 33 ft.	Indication Only
SC84-TY-K002A(B)**	Air Temperature Difference	Indication Only

*Two channels (SC84-ZE-N002A and B are separate channels) Total of 12 channels shown on this page. Only one (1) channel of two listed is required to be operable, A or B.
 **Temperature translator - requires SC84-TE-N003 A or B (temperature sensors at 162 ft.) and SC84-TE-N006 A or B (temperature sensors at 33 ft.) to be operable in order to obtain temperature difference.

DEFINITIONS FOR
 "CHANNELS", "TRIP SYSTEMS", AND "TRIP FUNCTIONS"
 FOR REMOTE SHUTDOWN MONITORING
 INSTRUMENTATION TABLE 3.3.7.4-1

<u>Indicator</u>	<u>Parameter</u>	<u>Function</u>
C61-PI-R401A	Reactor Vessel Pressure	Indication Only
C61-PI-R401B	*Reactor Vessel Pressure	Indication Only
C61-LI-R400A	Reactor Vessel Water Level	Indication Only
C61-LI-R400B	Reactor Vessel Water Level	Indication Only
C61-LI-R402A	Suppression Pool Water Level	Indication Only
C61-LI-R402B	Suppression Pool Water Level	Indication Only
C61-TI-R403A	Suppression Pool Wtr Temperature	Indication Only
C61-TI-R403B	Suppression Pool Wtr Temperature	Indication Only
C61-FI-R200A	RHR System A Flow	Indication Only
C61-FI-R200B	RHR System B Flow	Indication Only
C61-FI-R001A	Standby Service Wtr System A Flow	Indication Only
C61-FI-R001B	Standby Service Wtr System B Flow	Indication Only
C61-SI-R101	RCIC Turbine Speed	Indication Only
C61-LI-R102	Condensate Storage Tank Level	Indication Only

* One Channel (Typical of 14 shown on this page)

DEFINITIONS FOR
"CHANNELS", "TRIP SYSTEMS", AND "TRIP FUNCTIONS"
FOR ACCIDENT MONITORING INSTRUMENTATION - TABLE 3.3.7.5-1

<u>Transmitter/Sensor</u>	<u>Parameter</u>	<u>Recorder</u>	<u>Function</u>
B21-PT-N062A	Reactor Vessel Pressure	B21-UR-R623A	Monitor
B21-PT-N062B	Reactor Vessel Pressure	B21-UR-R623B	Monitor
B21-LT-N091A	Reactor Vessel Level	B21-UR-R623A	Monitor
B21-LT-N091B	Reactor Vessel Level	B21-UR-R623B	Monitor
E30-LT-N003C	Supp. Pool Water Level	E30-LR-R600A	Monitor
E30-LT-N003D	Supp. Pool Water Level	E30-LR-R600B	Monitor
(a) M71-TE-N012A(B)	Supp. Pool Temp. (Az 40°)	M71-TR-R605A(B)	Monitor
(a) M71-TE-N022A(B)	Supp. Pool Temp. (Az 82°)		
(a) M71-TE-N023A(B)	Supp. Pool Temp. (Az 142°)		
(a) M71-TE-N024A(B)	Supp. Pool Temp. (Az 180°)	M71-TR-R605C(D)	Monitor
(a) M71-TE-N025A(B)	Supp. Pool Temp. (Az 262°)		
(a) M71-TE-N026A(B)	Supp. Pool Temp. (Az 318°)		
E61-PDT-N014A	*Ctmt/DW Diff. Pressure	E61-PDR-R601A	Monitor
E61-PDT-N014B	Ctmt/DW Diff. Pressure	E61-PDR-R601B	Monitor
M71-PDT-N001A	Drywell Pressure	M71-PDR-R601A	Monitor
M71-PDT-N001B	Drywell Pressure	M71-PDR-R601B	Monitor
** M71-TE-N013A(B)	CRD Cavity Temp.	M71-TR-R602A(B)	Monitor
** M71-TE-N013C(D)	CRD Cavity Temp.	M71-TR-R603A(B)	Monitor
** M71-TE-N008A(B)	Drywell Temp. - 166' El.	M71-TR-R602A(B)	Monitor
** M71-TE-N008C(D)	Drywell Temp. - 166' El.	M71-TR-R603A(B)	Monitor
E61-AITS-K002A	Ctmt H ₂ Conc. Analyzer	E61-AR-R602A	Monitor
E61-AITS-K002B	Ctmt H ₂ Conc. Analyzer	E61-AR-R602B	Monitor
E61-AITS-K001A	DW H ₂ Conc. Analyzer	E61-AR-R602A	Monitor
E61-AITS-K001B	DW H ₂ Conc. Analyzer	E61-AR-R602B	Monitor
M71-PDT-N002A	Ctmt Narrow Range Pressure	M71-PDR-R601A	Monitor
M71-PDT-N002B	Ctmt Narrow Range Pressure	M71-PDR-R601B	Monitor
M71-PDT-N027A	Ctmt Wide Range Pressure	M71-PDR-R601A	Monitor
M71-PDT-N027B	Ctmt Wide Range Pressure	M71-PDR-R601B	Monitor
** M71-TE-N007A(B)	Ctmt Temp. - 139' El.	M71-TR-R602A(B)	Monitor
** M71-TE-N007C(D)	Ctmt Temp. - 139' El.	M71-TR-R603A(B)	Monitor

* One Channel (typical of 42 shown on this page)

** Only one channel of two listed is required (i.e., either M71-TE-N013A or M71-TE-N013B)

(a) Only six of the twelve channels are required, either A or B, from each sector location.

DEFINITIONS FOR
 "CHANNELS", "TRIP SYSTEMS", AND "TRIP FUNCTIONS"
 FOR ACCIDENT MONITORING INSTRUMENTATION TABLE 3.3.7.5-1 (Continued)

<u>Transmitter/Sensor</u>	<u>Parameter</u>	<u>Recorder</u>	<u>Function</u>
D17-RE-N126	Ctmt Vent. Acc Med. Range Mont	Eberline CT-1 (Computer Terminal)	Monitor
D17-RE-N127	Ctmt Vent. Acc Hi Range Mont		
SD17-RE-N120	*OG & RW Vent. Acc. Med Range Mont.	Eberline CT-1 (Computer Terminal)	Monitor
SD17-RE-N121	OG & RW Vent. Acc. Hi Range Mont.		
D17-RE-N132	FHA Vent. Acc. Med Range Mont.	Eberline CT-1 (Computer Terminal)	Monitor
D17-RE-N133	FHA Vent. Acc. Hi Range Mont.		
D17-RE-N138	TB Vent. Acc. Med Range Mont.	Eberline CT-1 (Computer Terminal)	Monitor
D17-RE-N139	TB Vent. Acc. Hi Range Mont.		
D17-RE-N144	SGTS "B" Vent. Acc. Med Range Mont.	Eberline CT-1 (Computer Terminal)	Monitor
D17-RE-N145	SGTS "B" Vent. Acc. Hi Range Mont.		
D17-RE-N150	SGTS "A" Vent. Acc. Med Range Mont.	Eberline CT-1 (Computer Terminal)	Monitor
D17-RE-N151	SGTS "A" Vent. Acc. Hi Range Mont.		

* One channel (Typical of 6 shown on this page). Each Channel consists of two transmitters/sensors. Both medium range and high range are required for the channel to be operable.

DEFINITIONS FOR
"CHANNELS", "TRIP SYSTEMS", AND "TRIP FUNCTIONS"
FOR SOURCE RANGE MONITORS 3.3.7.6

<u>Sensor</u>	<u>Parameter</u>	<u>Function</u>
C51-N001A	SRM	Monitor
C51-N001B	SRM	Monitor
C51-N001C	SRM	Monitor
C51-N001D	*SRM	Monitor
C61-N001E	SRM	Monitor
C51-N001F	SRM	Monitor

* One Channel (Typical of 6 shown on this page)

DEFINITIONS FOR
"CHANNELS", "TRIP SYSTEMS", AND "TRIP FUNCTIONS"
FOR TRAVERSING-IN-CORE PROBE SYSTEM 3.3.7.7

<u>Sensor</u>	<u>Parameter</u>	<u>Function</u>
C51-N003A	TIP-SYS-CH.A	Monitor & Calibration
C51-N003B	TIP-SYS-CH.B	Monitor & Calibration
C51-N003C	TIP-SYS-CH.C	Monitor & Calibration
C51-N003D	TIP-SYS-CH.D	Monitor & Calibration
C51-N003E	*TIP-SYS-CH.E	Monitor & Calibration

* One Channel (Typical of 5 shown on this page)
Only three of five TIPs are presently required operable.

DEFINITIONS FOR
"CHANNELS", "TRIP SYSTEMS", AND "TRIP FUNCTIONS"
FOR THE CHLORINE DETECTION SYSTEM 3.3.7.8

<u>Trip Unit</u>	<u>Parameter</u>	<u>Function</u>
SZ51-AS-N040A	*Chlorine Conc - HI	Actuates Control Rm Isolation Logic A
SZ51-AS-N040B	Chlorine Conc - HI	Actuates Control Rm Isolation Logic B

* One Channel (Typical of 2 shown on this page)

DEFINITIONS FOR
 "CHANNELS", "TRIP SYSTEMS", AND "TRIP FUNCTIONS"
 FOR FIRE DETECTION INSTRUMENTATION TABLE 3.3.7.9-1

Detector	Parameter	Logic	Function
<u>Containment Building</u>			
M41-XS-N057A	Containment Bldg. Return Duct Mounted Detectors	Any One	Produces an Alarm, Stop Containment Cooler Fans
M41-XS-N057B	Containment Bldg. Return Duct Mounted Detectors		
M41-XS-N057C	Containment Bldg. Return Duct Mounted Detectors		
<u>Control Building</u>			
SZ51-XS-N030A	Control Rm. Vent. A/C Unit A El. 133'	Any One	Produces an Alarm and Stops Respective Fan
SZ51-XS-N030B	Control Rm. Vent. A/C Unit B El. 133'		
SP65-XS-N503A	Emer. Laundry El. 93' Zone 1-3 (OC103)	Any One	Produces An Alarm
SP65-XS-N503B	Decon. Area El. 93' Zone 1-3 (OC109)		
SP65-XS-N503C	Hot Machine Shop El. 93' Zone 1-3 (OC116)		
SP65-XS-N503D	Hot Machine Shop El. 93' Zone 1-3 (OC116)		
SP65-XS-N503E	Hot Machine Shop El. 93' Zone 1-3 (OC116)		
SP65-XS-N503F	Hot Machine Shop El. 93' Zone 1-3 (OC116)		
SP65-XS-N503G	Hot Machine Shop El. 93' Zone 1-3 (OC116)		
SP65-XS-N503H	Hot Water Heater Rm. El. 93' Zone 1-3 (OC128)		
SP65-XS-N503I	*Corridor El. 93' Zone 1-3 (OC115)		
SP65-XS-N503J	Corridor El. 93' Zone 1-3 (OC115)		
SP65-XS-N503K	Corridor El. 93' Zone 1-3 (OC115)		
SP65-XS-N503L	Corridor El. 93' Zone 1-3 (OC117)		
SP65-XS-N504A	Div 1 SWGR Room El 111' Zone 1-4 (OC202)	Any One	Produces An Alarm
SP65-XS-N504B	Div 1 SWGR Room El 111' Zone 1-4 (OC202)		
SP65-XS-N504C	Div 1 SWGR Room El 111' Zone 1-4 (OC202)		
SP65-XS-N504D	Div 1 SWGR Room El 111' Zone 1-4 (OC202)		
SP65-XS-N504E	Div I Battery Room El 111' Zone 1-4 (OC207)	Any One	Produces An Alarm Disch CO ₂ and Closes Dampers
SP65-XS-N504F	Stair El 111' Zone 1-4 (OC201)		
SP64-TS-N137A	Div 1 SWGR Room El 111' Zone 1-4 (OC202)		
SP64-TS-N137B	Div 1 SWGR Room El 111' Zone 1-4 (OC202)		
SP64-TS-N137C	Div 1 SWGR Room El 111' Zone 1-4 (OC202)		
SP64-TS-N137D	Div 1 SWGR Room El 111' Zone 1-4 (OC202)		
SP64-TS-N137E	Div 1 SWGR Room El 111' Zone 1-4 (OC202)		
SP64-TS-N137F	Div 1 SWGR Room El 111' Zone 1-4 (OC202)		
SP65-XS-N505B	Div III Batt. Rm El 111' Zone 1-5 (OC209)		
SP65-XS-N505C	Div III SWGR Rm El 111' Zone 1-5 (OC210)		
SP65-XS-N505D	Div III SWGR Rm El 111' Zone 1-5 (OC210)	Any One	Produces An Alarm Disch CO ₂ and Closes Dampers
SP64-TS-N139A	Div III SWGR Rm El 111' Zone 1-5 (OC210)		
SP64-TS-N139B	Div III SWGR Rm El 111' Zone 1-5 (OC210)		
SP64-TS-N139C	Div III SWGR Rm El 111' Zone 1-5 (OC210)		
SP64-TS-N139D	Div III SWGR Rm El 111' Zone 1-5 (OC210)		

* One Channel (Typical of 36 shown on this page)

DEFINITIONS FOR
"CHANNELS", "TRIP SYSTEMS", AND "TRIP FUNCTIONS"
FOR FIRE DETECTION INSTRUMENTATION TABLE 3.3.7.9-1 (Continued)

Detector	Parameter	Logic	Function		
SP65-XS-N506A	Div II Batt. Rm El 111' Zone 1-6 (OC211)	Any One	Produces An Alarm		
SP65-XS-N506B	Div II SWGR Rm El 111' Zone 1-6 (OC215)				
SP65-XS-N506C	Div II SWGR Rm El 111' Zone 1-6 (OC215)				
SP65-XS-N506D	Div II SWGR Rm El 111' Zone 1-6 (OC215)				
SP65-XS-N506E	Div II SWGR Rm El 111' Zone 1-6 (OC215)				
SP65-XS-N506F	W. Corridor El 111' Zone 1-6 (OC216)				
SP65-XS-N506G	W. Corridor El 111' Zone 1-6 (OC216)				
SP64-TS-N138A	Div II SWGR Rm El. 111' Zone 1-6 (OC215)				
SP64-TS-N138B	Div II SWGR Rm El. 111' Zone 1-6 (OC215)				
SP64-TS-N138C	*Div II SWGR Rm El. 111' Zone 1-6 (OC215)			Any One	Produces An Alarm, Disch CO ₂ and Closes Dampers.
SP64-TS-N138D	Div II SWGR Rm El. 111' Zone 1-6 (OC215)				
SP64-TS-N138E	Div II SWGR Rm El. 111' Zone 1-6 (OC215)				
SP64-TS-N138F	Div II SWGR Rm El. 111' Zone 1-6 (OC215)				
SP64-TS-N138G	Div II SWGR Rm El. 111' Zone 1-6 (OC215)				
SP65-XS-N510A	Electrical Chase El. 133' Zone 1-10 (OC306)	Any One	Produces An Alarm		
SP65-XS-N510B	Electrical Chase El. 133' Zone 1-10 (OC307)				
SP65-XS-N511A	HVAC Equip Rm El. 133' Zone 1-11 (OC302)	Any One	Produces An Alarm, starts Control Building Purge Fan		
SP65-XS-N511B	HVAC Equip Rm El. 133' Zone 1-11 (OC302)				
SP65-XS-N511C	HVAC Equip Rm El. 133' Zone 1-11 (OC302)				
SP65-XS-N511D	HVAC Equip Rm El. 133' Zone 1-11 (OC302)				
SP65-XS-N511E	HVAC Equip Rm El. 133' Zone 1-11 (OC302)				
SP65-XS-N511F	HVAC Equip Rm El. 133' Zone 1-11 (OC302)				
SP65-XS-N511G	HVAC Equip Rm El. 133' Zone 1-11 (OC302)				
SP65-XS-N511H	HVAC Equip Rm El. 133' Zone 1-11 (OC302)				
SP65-XS-N511I	HVAC Equip Rm El. 133' Zone 1-11 (OC302)				
SP65-XS-N511J	HVAC Equip Rm El. 133' Zone 1-11 (OC302)				
SP65-XS-N511K	HVAC Equip Rm El. 133' Zone 1-11 (OC302)				
SP65-XS-N511L	HVAC Equip Rm El. 133' Zone 1-11 (OC302)				
SP65-XS-N511M	Corridor El. 133' Zone 1-11 (OC308)				
SP65-XS-N512A	Electrical Spaces El 133' Zone 1-12 (OC304/OC412)			Any One	Produces An Alarm
SP65-XS-N512B	Electrical Space El. 133' Zone 1-12 (OC305)				
SP65-XS-N513A	HVAC Equip. Rm. El. 133' Zone 1-13 (OC303)	Any One	Produces An Alarm, starts Control Building Purge Fan		
SP65-XS-N513B	HVAC Equip. Rm. El. 133' Zone 1-13 (OC303)				
SP65-XS-N513C	HVAC Equip. Rm. El. 133' Zone 1-13 (OC303)				
SP65-XS-N513D	HVAC Equip. Rm. El. 133' Zone 1-13 (OC303)				
SP65-XS-N513E	HVAC Equip. Rm. El. 133' Zone 1-13 (OC303)				
SP65-XS-N513F	HVAC Equip. Rm. El. 133' Zone 1-13 (OC303)				
SP65-XS-N513G	HVAC Equip. Rm. El. 133' Zone 1-13 (OC303)				
SP65-XS-N513H	HVAC Equip. Rm. El. 133' Zone 1-13 (OC303)				
SP65-XS-N513I	HVAC Equip. Rm. El. 133' Zone 1-13 (OC303)				
SP65-XS-N513J	HVAC Equip. Rm. El. 133' Zone 1-13 (OC303)				
SP65-XS-N513K	HVAC Equip. Rm. El. 133' Zone 1-13 (OC303)				
SP65-XS-N513L	HVAC Equip. Rm. El. 133' Zone 1-13 (OC303)				
SP65-XS-N513M	HVAC Equip. Rm. El. 133' Zone 1-13 (OC303)				
SP65-XS-N513N	HVAC Equip. Rm. El. 133' Zone 1-13 (OC303)				
SP65-XS-N513O	HVAC Equip. Rm. El. 133' Zone 1-13 (OC303)				
SP65-XS-N513P	HVAC Equip. Rm. El. 133' Zone 1-13 (OC303)				

* One Channel (Typical of 47 shown on this page)

DEFINITIONS FOR
 "CHANNELS", "TRIP SYSTEMS", AND "TRIP FUNCTIONS"
 FOR FIRE DETECTION INSTRUMENTATION TABLE 3.3.7.9-1 (Continued)

<u>Detector</u>	<u>Parameter</u>	<u>Logic</u>	<u>Function</u>
SP65-XS-N514A	Computer Rm El. 148' Zone 1-14 (OC403)	Any	Produces An Alarm
SP65-XS-N514B	Computer Rm El. 148' Zone 1-14 (OC403)		
SP65-XS-N514C	Computer Rm El. 148' Zone 1-14 (OC403)		
SP65-XS-N514D	Computer Rm El. 148' Zone 1-14 (OC403)		
SP65-XS-N514E	HVAC Chase Zone 1-14 (OC402A)		
SP65-XS-N514F	Battery Rm El. 148' Zone 1-14 (OC410)		
SP65-XS-N514G	Computer Rm El. 148' Zone 1-14 (OC403)		
SP65-XS-N514H	Computer Rm El. 148' Zone 1-14 (OC403)		
SP65-XS-N514I	Computer Rm El. 148' Zone 1-14 (OC403)		
SP64-XS-N400A	Computer Rm El. 148' Zone 1-14 (OC403)		
SP64-XS-N400B	Computer Rm El. 148' Zone 1-14 (OC403)		
SP64-XS-N400C	*Computer Rm El. 148' Zone 1-14 (OC403)	One	Produces An Alarm, Disch. Halon, Closes Dampers and Stops Computer Room Supply and Exhaust Fans
SP64-XS-N400D	Computer Rm El. 148' Zone 1-14 (OC403)		
SP64-XS-N400E	Computer Rm El. 148' Zone 1-14 (OC403)		
SP64-XS-N400F	Computer Rm El. 148' Zone 1-14 (OC403)		
SP64-XS-N400G	Computer Rm El. 148' Zone 1-14 (OC403)		
SP64-XS-N400H	Computer Rm El. 148' Zone 1-14 (OC403)		
SP64-XS-N400J	Computer Rm El. 148' Zone 1-14 (OC403)		
SP64-XS-N400K	Computer Rm El. 148' Zone 1-14 (OC403)		
SP64-XS-N400L	Computer Rm El. 148' Zone 1-14 (OC403)		
SP64-XS-N400M	Computer Rm El. 148' Zone 1-14 (OC403)		
SP65-XS-N515A	Cable Spreading Rm El. 148' Zone 1-15 (OC402)		
SP65-XS-N515B	Cable Spreading Rm El. 148' Zone 1-15 (OC402)		
SP65-XS-N515C	Cable Spreading Rm El. 148' Zone 1-15 (OC402)		
SP65-XS-N515D	Cable Spreading Rm El. 148' Zone 1-15 (OC402)		
SP65-XS-N515E	Cable Spreading Rm El. 148' Zone 1-15 (OC402)		
SP65-XS-N515F	Cable Spreading Rm El. 148' Zone 1-15 (OC402)		
SP65-XS-N515G	Cable Spreading Rm El. 148' Zone 1-15 (OC402)		
SP65-XS-N515H	Instr. Motor Gen Room El. 148' Zone 1-15 (OC407)		
SP65-XS-N515I	Elec. Space El. 148' Zone 1-15 (OC409)		
SP65-XS-N515J	Corridor El. 148' Zone 1-15 (OC401)		
SP65-XS-N515K	Cable Spreading Rm El. 148' Zone 1-15 (OC402)		
SP65-XS-N515L	Cable Spreading Rm El. 148' Zone 1-15 (OC402)		
SP65-XS-N515M	Cable Spreading Rm El. 148' Zone 1-15 (OC402)		
SP65-XS-N515N	Corridor El. 148' Zone 1-15 (OC408)		
SP65-XS-N515O	Corridor El. 148' Zone 1-15 (OC408)		

* One Channel (Typical of 36 shown on this page)

DEFINITIONS FOR
 "CHANNELS", "TRIP SYSTEMS", AND "TRIP FUNCTIONS"
 * FOR FIRE DETECTION INSTRUMENTATION TABLE 3.3.7.9-1 (Continued)

<u>Detector</u>	<u>Parameter</u>	<u>Logic</u>	<u>Function</u>		
SP64-TS-N143A	Cable Spreading Rm El. 148' Zone 1-15 (OC402)	} Any One	Produces An Alarm, Disch. CO ₂ and Closes Dampers.		
SP64-TS-N143B	Cable Spreading Rm El. 148' Zone 1-15 (OC402)				
SP64-TS-N143C	*Cable Spreading Rm El. 148' Zone 1-15 (OC402)				
SP64-TS-N143D	Cable Spreading Rm El. 148' Zone 1-15 (OC402)				
SP64-TS-N143E	Cable Spreading Rm El. 148' Zone 1-15 (OC402)				
SP64-TS-N143F	Cable Spreading Rm El. 148' Zone 1-15 (OC402)				
SP64-TS-N143G	Cable Spreading Rm El. 148' Zone 1-15 (OC402)				
SP64-TS-N144A	Instr. Motor Gen Room El. 148' Zone 1-15 (OC407)			} Any One	Produces An Alarm, Disch. CO ₂ and Closes Dampers.
SP64-TS-N144B	Instr. Motor Gen Room El. 148' Zone 1-15 (OC407)				

* One Channel (Typical of 9 shown on this page)

DEFINITIONS FOR
 "CHANNELS", "TRIP SYSTEMS", AND "TRIP FUNCTIONS"
 FOR FIRE DETECTION INSTRUMENTATION TABLE 3.3.7.9-1 (Continued)

<u>Detector</u>	<u>Parameter</u>	<u>Logic</u>	<u>Function</u>
SP65-XS-N518A	Instr. Rack Space El. 166' Zone 1-18 (OC502)	}	Any - Produces One - An Alarm
SP65-XS-N518B	Control Room El. 166' Zone 1-18 (OC503)		
SP65-XS-N518C	Control Room El. 166' Zone 1-18 (OC503)		
SP65-XS-N518D	Control Room El. 166' Zone 1-18 (OC503)		
SP65-XS-N518E	Control Room Instr. Rack Space El. 166' Zone 1-18 (OC504)		
SP65-XS-N518F	Instr. Rack Space El. 166' Zone 1-18 (OC502)		
SP65-XS-N518G	Instr. Rack Space El. 166' Zone 1-18 (OC502)		
SP65-XS-N518H	*Control Room El. 166' Zone 1-18 (OC503)		
SP65-XS-N518I	Control Room Instr. Rack Space El. 166' Zone 1-18 (OC504)		
SP65-XS-N518J	Control Room Instr. Rack Space El. 166' Zone 1-18 (OC504)		
SP65-XS-N518K	Instr. Rack Space El. 166' Zone 1-18 (OC502)		
SP65-XS-N518L	Instr. Rack Space El. 166' Zone 1-18 (OC502)		
SP65-XS-N518M	Control Room El. 166' Zone 1-18 (OC503)		
SP65-XS-N518N	Control Room Instr. Rack Space El. 166' Zone 1-18 (OC504)		
SP65-XS-N518O	Control Room Instr. Rack Space El. 166' Zone 1-18 (OC504)		
SP65-XS-N518P	Control Room Instr. Rack Space El. 166' Zone 1-18 (OC504)		
SP65-XS-N518Q	Control Room El. 166' Zone 1-18 (OC503)		
SP65-XS-N518R	Instr. Rack Space El. 166' Zone 1-18 (OC502)		
SP65-XS-N518S	Instr. Rack Space El. 166' Zone 1-18 (OC502)		
SP65-XS-N518T	Control Room El. 166' Zone 1-18 (OC503)		
SP65-XS-N518U	Control Room El. 166' Zone 1-18 (OC503)		
SP65-XS-N518V	Control Room Instr. Rack Space El. 166' Zone 1-18 (OC504)		
SP65-XS-N518W	Control Room Instr. Rack Space El. 166' Zone 1-18 (OC504)		
SP65-XS-N518X	Control Room Instr. Rack Space El. 166' Zone 1-18 (OC504)		
SP65-XS-N518Y	Control Room El. 166' Zone 1-18 (OC503)		
SP65-XS-N518Z	Control Room El. 166' Zone 1-18 (OC503)		
SP65-XS-N518AA	Instr. Rack Space El. 166' Zone 1-18 (OC502)		
SP65-XS-N518BB	Control Room El. 166' Zone 1-18 (OC503)		
SP65-XS-N518CC	Control Room El. 166' Zone 1-18 (OC503)		
SP65-XS-N518DD	Instr. Rack Space El. 166' Zone 1-18 (OC502)		
SP65-XS-N518EE	Instr. Rack Space El. 166' Zone 1-18 (OC502)		

* One Channel (Typical of 31 shown on this page)

DEFINITIONS FOR
"CHANNELS", "TRIP SYSTEMS", AND "TRIP FUNCTIONS"
FOR FIRE DETECTION INSTRUMENTATION TABLE 3.3.7.9-1 (Continued)

<u>Detector</u>	<u>Parameter</u>	<u>Logic</u>	<u>Function</u>	
SP65-XS-N519A	*Instrument Shop El. 166' Zone 1-19 (OC507)	Any One	Produces An Alarm	
SP65-XS-N519B	Instrument Shop El. 166' Zone 1-19 (OC507)			
SP65-XS-N519C	Instrument Shop El. 166' Zone 1-19 (OC507)			
SP65-XS-N519D	Office El. 166' Zone 1-19 (OC510)			
SP65-XS-N519E	Dining Area/Kitchen El. 166' Zone 1-19 (OC511/OC512)			
SP65-XS-N519F	Locker Room/Shower El. 166' Zone 1-19 (OC514/OC506)			
SP65-XS-N519G	Locker Room El. 166' Zone 1-19 (OC514)			
SP65-XS-N519H	Corridor El. 166' Zone 1-19 (OC509)			
SP65-XS-N519I	Corridor El. 166' Zone 1-19 (OC515)			
SP65-XS-N520A	HVAC Chase El. 189' Zone 1-20 (OC708A)			Produces An Alarm
SP65-XS-N521B	Electrical Space El. 166' Zone 1-21 (OC518)			Any One
SP65-XS-N521D	Electrical Space El. 177' Zone 1-21 (OC611)			
SP65-XS-N522A	Emer. Dorm./Storage Closet El. 177' Zone 1-22 (OC603/OC616)	Any One	Produces An Alarm	
SP65-XS-N522B	Emer. Dorm./Storage Closet El. 177' Zone 1-22 (OC603/OC616)			
SP65-XS-N522C	Comp. Rm. El. 177' Zone 1-22 (OC604)			
SP65-XS-N522D	Electrical Chase El. 177' Zone 1-22 (OC619)			
SP65-XS-N522E	Viewing Gallery El. 177' Zone 1-22 (OC601)			
SP65-XS-N522F	Electrical Chase El. 177' Zone 1-22 (OC618)			
SP65-XS-N522G	Viewing Gallery El. 177' Zone 1-22 (OC601)			
SP65-XS-N522H	Electrical Chase El. 177' Zone 1-22 (OC617)			
SP65-XS-N522I	Tech Support Center El. 177' Zone 1-22 (OC608)			
SP65-XS-N522J	Tech Support Center El. 177' Zone 1-22 (OC608)			
SP65-XS-N522K	Janitor Closet El. 177' Zone 1-22 (OC605)			
SP65-XS-N522L	Corridor El. 177' Zone 1-22 (OC614)			
SP65-XS-N522M	Corridor El. 177' Zone 1-22 (OC602)			
SP65-XS-N522N	Corridor El. 177' Zone 1-22 (OC613)			
SP65-XS-N522O	Stair El. 177' Zone 1-22 (OC03)			
SP65-XS-N522P	HVAC Chase El. 177' Zone 1-22 (OC608B)			

* One Channel (Typical of 28 shown on this page)

DEFINITIONS FOR
"CHANNELS", "TRIP SYSTEMS", AND "TRIP FUNCTIONS"
FOR FIRE DETECTION INSTRUMENTATION TABLE 3.3.7.9-1 (Continued)

<u>Detector</u>	<u>Parameter</u>	<u>Logic</u>	<u>Function</u>		
SP65-XS-N523A	Cable Spreading Rm El. 189' Zone 1-23 (OC702)				
SP65-XS-N523B	Cable Spreading Rm El. 189' Zone 1-23 (OC702)				
SP65-XS-N523C	Cable Spreading Rm El. 189' Zone 1-23 (OC702)				
SP65-XS-N523D	*Cable Spreading Rm El. 189' Zone 1-23 (OC702)				
SP65-XS-N523U	HVAC Rm El. 189' Zone 1-23 (OC712)	Any One	Produces An Alarm		
SP65-XS-N523E	Cable Spreading Rm El. 189' Zone 1-23 (OC702)				
SP65-XS-N523F	Cable Spreading Rm El. 189' Zone 1-23 (OC702)				
SP65-XS-N523G	Cable Spreading Rm El. 189' Zone 1-23 (OC702)				
SP65-XS-N523H	Instr. Mtr. Gen Rm El. 189' Zone 1-23 (OC707)				
SP65-XS-N523I	Cable Spreading Rm El. 189' Zone 1-23 (OC702)				
SP65-XS-N523J	Cable Spreading Rm El. 189' Zone 1-23 (OC702)				
SP65-XS-N523K	Passage El. 189' Zone 1-23 (OC711)				
SP65-XS-N523L	Cable Spreading Rm El. 189' Zone 1-23 (OC702)				
SP65-XS-N523M	Cable Spreading Rm El. 189' Zone 1-23 (OC702)				
SP65-XS-N523N	Cable Spreading Rm El. 189' Zone 1-23 (OC702)				
SP65-XS-N523O	Cable Spreading Rm El. 189' Zone 1-23 (OC702)				
SP65-XS-N523P	Cable Spreading Rm El. 189' Zone 1-23 (OC702)				
SP65-XS-N523Q	Corridor El. 189' Zone 1-23 (OC706)				
SP65-XS-N523R	Corridor El. 189' Zone 1-23 (OC706)				
SP65-XS-N523S	Corridor El. 189' Zone 1-23 (OC706)				
SP65-XS-N523T	Electrical Spaces El. 189' Zone 1-23 (OC709)				
SP64-TS-N145A	Cable Spreading Rm El. 189' Zone 1-23 (OC702)			Any One	Produces An Alarm, Disch. CO ₂ and Closes Dampers.
SP64-TS-N145B	Cable Spreading Rm El. 189' Zone 1-23 (OC702)				
SP64-TS-N145C	Cable Spreading Rm El. 189' Zone 1-23 (OC702)				
SP64-TS-N145D	Cable Spreading Rm El. 189' Zone 1-23 (OC702)				
SP64-TS-N145E	Cable Spreading Rm El. 189' Zone 1-23 (OC702)				
SP64-TS-N145F	Cable Spreading Rm El. 189' Zone 1-23 (OC702)				
SP64-TS-N145G	Cable Spreading Rm El. 189' Zone 1-23 (OC702)				
SP64-TS-N145H	Cable Spreading Rm El. 189' Zone 1-23 (OC702)				
SP64-TS-N145I	Cable Spreading Rm El. 189' Zone 1-23 (OC702)				
SP64-TS-N145J	Cable Spreading Rm El. 189' Zone 1-23 (OC702)				
SP64-TS-N145K	Cable Spreading Rm El. 189' Zone 1-23 (OC702)				
SP64-TS-N145L	Cable Spreading Rm El. 189' Zone 1-23 (OC702)				
SP65-XS-N524A	Control Cab Rm El. 189' Zone 1-24 (OC703)	Any One	Produces An Alarm		
SP65-XS-N524B	Control Cab Rm El. 189' Zone 1-24 (OC703)				
SP65-XS-N524C	Control Cab Rm El. 189' Zone 1-24 (OC703)				
SP65-XS-N524D	Control Cab Rm El. 189' Zone 1-24 (OC703)				
SP65-XS-N524E	Control Cab Rm El. 189' Zone 1-24 (OC703)				
SP65-XS-N524F	Control Cab Rm El. 189' Zone 1-24 (OC703)				
SP64-TS-N146A	Control Cab Room El. 189' Zone 1-24 (OC703)	Any One	Produces An Alarm. and Closes Dampers. **		
SP64-TS-N146B	Control Cab Room El. 189' Zone 1-24 (OC703)				
SP64-TS-N146C	Control Cab Room El. 189' Zone 1-24 (OC703)				
SP64-TS-N146D	Control Cab Room El. 189' Zone 1-24 (OC703)				

* One Channel (Typical of 44 shown on this page)

** Manual actuation required for CO₂ discharge.

DEFINITIONS FOR
"CHANNELS", "TRIP SYSTEMS", AND "TRIP FUNCTIONS"
FOR FIRE DETECTION INSTRUMENTATION TABLE 3.3.7.9-1 (Continued)

Detector	Parameter	Logic	Function		
SP65-XS-N505E	Div II Remote Shutdown Panel Rm El 111' Zone 1-27 (OC208)	Any One	Produces An Alarm and Closes the Door		
SP65-XS-N505A	*Div I Remote Shutdown Panel Rm El 111' Zone 1-27 (OC208A)				
SP64-TS-N142A	Div II Remote Shutdown Panel Rm El 111' Zone 1-27 (OC208)	Any One	Produces An Alarm Disch CO ₂ and Closes Dampers.		
SP64-TS-N142B	Div I Remote Shutdown Panel Rm El 11. ' Zone 1-27 (OC208A)				
<u>Auxiliary Building</u>					
SP65-XS-N527A	West Corridor El. 119' Zone 2-2 (1A222)	Any One	Produces An Alarm		
SP65-XS-N527B	West Corridor El. 119' Zone 2-2 (1A222)				
SP65-XS-N527C	West Corridor El. 119' Zone 2-2 (1A222)				
SP65-XS-N527D	West Corridor El. 119' Zone 2-2 (1A222)				
SP65-XS-N527E	West Corridor El. 119' Zone 2-2 (1A222)				
SP65-XS-N527F	West Corridor El. 119' Zone 2-2 (1A222)				
SP65-XS-N527G	West Corridor El. 119' Zone 2-2 (1A222)				
SP65-XS-N527H	West Corridor El. 119' Zone 2-2 (1A222)				
SP65-XS-N527I	West Corridor El. 119' Zone 2-2 (1A222)				
SP65-XS-N527J	West Corridor El. 119' Zone 2-2 (1A222)				
SP65-XS-N527K	North Corridor El. 119' Zone 2-2 (1A211)				
SP65-XS-N527L	North Corridor El. 119' Zone 2-2 (1A211)				
SP65-XS-N527M	North Corridor El. 119' Zone 2-2 (1A211)				
SP65-XS-N527N	North Corridor El. 119' Zone 2-2 (1A211)				
SP65-XS-N527O	West Corridor El. 119' Zone 2-2 (1A222)				
SP65-XS-N527P	West Corridor El. 119' Zone 2-2 (1A222)				
SP65-XS-N527Q	West Corridor El. 119' Zone 2-2 (1A222)				
SP65-XS-N527R	West Corridor El. 119' Zone 2-2 (1A222)				
SP65-XS-N527S	South Corridor El. 119' Zone 2-2 (1A215)				
SP65-XS-N527T	South Corridor El. 119' Zone 2-2 (1A215)				
SP65-XS-N527U	South Corridor El. 119' Zone 2-2 (1A215)				
SP65-XS-N527V	South Corridor El. 119' Zone 2-2 (1A215)				
SP65-XS-N527W	South Corridor El. 119' Zone 2-2 (1A215)				
SP64-TS-N1C30A	Elect SWGR Rm El. 119' Zone 2-3 (1A219)			Any One	Produces An Alarm, Disch. CO ₂ .
SP64-TS-N1C30B	Elect SWGR Rm El. 119' Zone 2-3 (1A219)				
SP65-XS-N528A	Elect SWGR Rm El. 119' Zone 2-3 (1A219)			Any One	Produces An Alarm
SP65-XS-N528B	Elect SWGR Rm El. 119' Zone 2-3 (1A219)				
SP65-XS-N528C	Electric SWGR Rm El. 119', Zone 2-3 (1A221)	Any One	Produces an Alarm, Disch. CO ₂		
SP65-XS-N528D	Electric SWGR Rm El. 119', Zone 2-3 (1A221)				
SP65-XS-N528E	Piping Penet Rm El. 119' Zone 2-3 (1A220)	Any One	Produces an Alarm, Disch. CO ₂		
SP64-TS-N1D30A	Electric SWGR Rm El. 119', Zone 2-3 (1A221)				
SP64-TS-N1D30B	Electric SWGR Rm El. 119', Zone 2-3 (1A221)				

* One Channel (Typical of 36 shown on this page)

DEFINITIONS FOR
 "CHANNELS", "TRIP SYSTEMS", AND "TRIP FUNCTIONS"
 FOR FIRE DETECTION INSTRUMENTATION TABLE 3.3.7.9-1 (Continued)

Detector	Parameter	Logic	Function		
SP65-XS-N625J	RHR "A" Ht Ex Rm El. 93'/108' Zone 2-4 (1A102/1A128)	}			
SP65-XS-N625H	RHR "A" Pump Rm El. 93' Zone 2-4 (1A103)				
SP65-XS-N625I	RHR "A" Pump Rm El. 93' Zone 2-4 (1A103)				
SP65-XS-N625F	RCIC Pump Room EL. 93' Zone 2-4 (1A104)				
SP65-XS-N625G	RCIC Pump Room EL. 93' Zone 2-4 (1A104)				
SP65-XS-N625D	RHR "B" Pump Room El. 93' Zone 2-4 (1A105)				
SP65-XS-N625E	RHR "B" Pump Room El. 93' Zone 2-4 (1A105)				
SP65-XS-N625C	RHR "B" Ht Ex Rm El. 93'/108' Zone 2-4 (1A106/1A129)				
SP65-XS-N529E	*RHR "A" Hx Rm El. 119' Zone 2-4 (1A202)			Any One	Produces An Alarm
SP65-XS-N627F	Piping Penetration Rm El. 119' Zone 2-4 (1A203)			}	
SP65-XS-N627G	Piping Penetration Rm El. 119' Zone 2-4 (1A203)				
SP65-XS-N627D	Piping Penetration Rm El. 119' Zone 2-4 (1A204)				
SP65-XS-N627E	Piping Penetration Rm El. 119' Zone 2-4 (1A204)				
SP65-XS-N627A	RHR "B" Hx Room El. 119' Zone 2-4 (1A206)				
SP65-XS-N627B	Piping Penetration Rm El. 119' Zone 2-4 (1A205)				
SP65-XS-N627C	Piping Penetration Rm El. 119' Zone 2-4 (1A205)				
SP65-XS-N627I	RWCU Recirc Pump A Rm, El. 115' Zone 2-4 (1A209)				
SP65-XS-N627H	RWCU Recirc Pump B Rm/Passage, El. 115' Zone 2-4 (1A210/1A223)				
SP65-XS-N529A	Elect SWGR Rm El. 119' Zone 2-4 (1A208)	}			
SP65-XS-N529B	Elect SWGR Rm El. 119' Zone 2-4 (1A208)				
SP65-XS-N529C	Elect SWGR Room El. 119' Zone 2-4 (1A207)				
SP65-XS-N529D	Elect SWGR Room El. 119' Zone 2-4 (1A207)				
SP64-TS-N1B30A	Elect SWGR Room El. 119' Zone 2-4 (1A207)			Any One	Produces An Alarm Disch. CO ₂
SP64-TS-N1B30B	Elect SWGR Room El. 119' Zone 2-4 (1A207)				
SP64-TS-N1A30A	Elect SWGR Rm El. 119' Zone 2-4 (1A208)			Any One	Produces An Alarm, Disch. CO ₂
SP64-TS-N1A30B	Elect SWGR Rm El. 119' Zone 2-4 (1A208)				
SP64-TS-N1A30C	Elect SWGR Rm El. 119' Zone 2-4 (1A208)				
SP64-TS-N1C31A	Elect Penet Rm El. 139' Zone 2-5 (1A318)			Any One	Produces An Alarm, Disch. CO ₂
SP64-TS-N1C31B	Elect Penet Rm El. 139' Zone 2-5 (1A318)				
SP65-XS-N530A	Elect Penet Rm El. 139' Zone 2-5 (1A318)	}			
SP65-XS-N530B	Elect Penet Rm El. 139' Zone 2-5 (1A318)				
SP65-XS-N530E	RPV Instr Test Rm El. 139' Zone 2-5 (1A319)			Any One	Produces An Alarm
SP65-XS-N530C	Elect Penet Rm El. 139' Zone 2-5 (1A320)				
SP65-XS-N530D	Elect Penet Rm El. 139' Zone 2-5 (1A320)				
SP64-TS-N1D31A	Elect Penet Rm El. 139' Zone 2-5 (1A320)			Any One	Produces An Alarm, Disch. CO ₂
SP64-TS-N1D31B	Elect Penet Rm El. 139' Zone 2-5 (1A320)				

* One Channel (Typical of 37 shown on this page)

DEFINITIONS FOR
 "CHANNELS", "TRIP SYSTEMS", AND "TRIP FUNCTIONS"
 FOR FIRE DETECTION INSTRUMENTATION TABLE 3.3.7.9-1 (Continued)

<u>Trip Unit</u>	<u>Parameter</u>	<u>Logic</u>	<u>Function</u>	
SP65-XS-N477L	Northeast Corridor El. 139' Zone 2-6 (1A301)	}		
SP65-XS-N477M	Northeast Corridor El. 139' Zone 2-6 (1A301)			
SP65-XS-N477N	South Corridor El. 139' Zone 2-6 (1A314)			
SP65-XS-N477A	*Southeast Corridor El. 139' Zone 2-6 (1A302)			
SP65-XS-N477D	North Corridor El. 139' Zone 2-6 (1A316)			
SP65-XS-N477E	North Corridor El. 139' Zone 2-6 (1A316)			
SP65-XS-N477O	South Corridor El. 139' Zone 2-6 (1A314)			
SP65-XS-N477P	Southeast Corridor El. 139' Zone 2-6 (1A302)			
SP65-XS-N477H	North Corridor El. 139' Zone 2-6 (1A316)			
SP65-XS-N477I	North Corridor El. 139' Zone 2-6 (1A316)			
SP65-XS-N477J	North Corridor El. 139' Zone 2-6 (1A316)			
SP65-XS-N477K	North Corridor El. 139' Zone 2-6 (1A316)			
SP65-XS-N477Q	RHR "A" Hx RM El. 139' Zone 2-6 (1A303)			
SP65-XS-N477T	Piping Penet Rm El. 139' Zone 2-6 (1A304)			
SP65-XS-N477S	Piping Penet Rm El. 139' Zone 2-6 (1A306)			
SP65-XS-N477R	RHR "B" Hx Rm El. 139' Zone 2-6 (1A307)			
SP65-XS-N477F	Elect Penet Rm El. 139' Zone 2-6 (1A308)			
SP65-XS-N477G	Elect Penet Rm El. 139' Zone 2-6 (1A308)			
SP65-XS-N477B	Elect Penet Rm El. 139' Zone 2-6 (1A309)			
SP65-XS-N477C	Elect Penet Rm El. 139' Zone 2-6 (1A309)			
SP65-XS-N706A	North Corridor El. 139' Zone 2-6 (1A316)			} Any Produces An One Alarm
SP65-XS-N706B	North Corridor El. 139' Zone 2-6 (1A316)			
SP65-XS-N706C	North Corridor El. 139' Zone 2-6 (1A316)			
SP65-XS-N706D	North Corridor El. 139' Zone 2-6 (1A316)			
SP65-XS-N706E	North Corridor El. 139' Zone 2-6 (1A316)			
SP65-XS-N706F	North Corridor El. 139' Zone 2-6 (1A316)			
SP65-XS-N531C	South Corridor El. 166' Zone 2-7 (1A420)			
SP65-XS-N531J	South Corridor El. 166' Zone 2-7 (1A420)			
SP65-XS-N531K	South Corridor El. 166' Zone 2-7 (1A420)			
SP65-XS-N531G	Set Down Area El. 166' Zone 2-7 (1A424)			
SP65-XS-N531H	Set Down Area El. 166' Zone 2-7 (1A424)			
SP65-XS-N531B	West Corridor El. 166' Zone 2-7 (1A428)			
SP65-XS-N531D	West Corridor El. 166' Zone 2-7 (1A428)			
SP65-XS-N531E	West Corridor El. 166' Zone 2-7 (1A428)			
SP65-XS-N531F	West Corridor El. 166' Zone 2-7 (1A428)			
SP65-XS-N531I	FPC & CU Pump Rm El. 166' Zone 2-7 (1A432)			
SP65-XS-N531A	S. Passage El. 166' Zone 2-7 (1A434)			
SP64-TS-N1B31A	Elect Penet Rm El. 139' Zone 2-6 (1A308)	} Any Produces An One Alarm, Disch		
SP64-TS-N1B31B	Elect Penet Rm El. 139' Zone 2-6 (1A308)			
SP64-TS-N1B31C	Elect Penet Rm El. 139' Zone 2-6 (1A308)	} Any Produces An One Alarm, Disch CO ₂		
SP64-TS-N1A31A	Elect Penet Rm El. 139' Zone 2-6 (1A309)			
SP64-TS-N1A31B	Elect Penet Rm El. 139' Zone 2-6 (1A309)			
SP64-TS-N1A31C	Elect Penet Rm El. 139' Zone 2-6 (1A309)			

* One Channel (Typical of 43 shown on this page)

DEFINITIONS FOR
 "CHANNELS", "TRIP SYSTEMS", AND "TRIP FUNCTIONS"
 FOR FIRE DETECTION INSTRUMENTATION TABLE 3.3.7.9-1 (Continued)

<u>Trip Unit</u>	<u>Parameter</u>	<u>Logic</u>	<u>Function</u>
SP65-XS-N707A	Northeast Corridor El. 166' Zone 2-8 (1A401)	Any One	Produces An Alarm
SP65-XS-N707B	North Corridor El. 166' Zone 2-8 (1A417)		
SP65-XS-N707C	North Corridor El. 166' Zone 2-8 (1A417)		
SP65-XS-N707D	North Corridor El. 166' Zone 2-8 (1A417)		
SP65-XS-N707E	North Corridor El. 166' Zone 2-8 (1A417)		
SP65-XS-N707F	North Corridor El. 166' Zone 2-8 (1A417)		
SP65-XS-N707G	North Corridor El. 166' Zone 2-8 (1A417)		
SP65-XS-N532E	North Corridor El. 166' Zone 2-8 (1A417)		
SP65-XS-N532F	North Corridor El. 166' Zone 2-8 (1A417)		
SP65-XS-N532G	North Corridor El. 166' Zone 2-8 (1A417)		
SP65-XS-N532H	North Corridor El. 166' Zone 2-8 (1A417)		
SP65-XS-N532J	North Corridor El. 166' Zone 2-8 (1A417)		
SP65-XS-N532N	*South Corridor El. 166' Zone 2-8 (1A420)		
SP65-XS-N532I	Set Down Area El. 166' Zone 2-8 (1A424)		
SP65-XS-N532C	Northeast Corridor El. 166' Zone 2-8 (1A401)		
SP65-XS-N532D	Northeast Corridor El. 166' Zone 2-8 (1A401)		
SP65-XS-N532O	Steam Tunnel Roof El. 166' Zone 2-8 (1A402)		
SP65-XS-N532L	Southeast Corridor El. 166' Zone 2-8 (1A403)		
SP65-XS-N532M	Southeast Corridor El. 166' Zone 2-8 (1A403)		
SP65-XS-N532P	Unassigned Area El. 166' Zone 2-8 (1A404)		
SP65-XS-N532Q	CTMT Vent Equip Rm El. 166' Zone 2-8 (1A405)		
SP65-XS-N532R	CTMT Exh Fltr Rm El. 166' Zone 2-8 (1A406)		
SP65-XS-N532B	MCC Area El. 166' Zone 2-8 (1A407)	Any One	Produces An Alm Disch. Co ₂
SP65-XS-N532K	S.E. Corridor El. 166' Zone 2-8 (1A403)		
SP65-XS-N532A	MCC Area El. 166' Zone 2-8 (1A410)		
SP64-TS-N1B32A	MCC Area El. 166' Zone 2-8 (1A407)		
SP64-TS-N1B32B	MCC Area El. 166' Zone 2-8 (1A407)		
SP64-TS-N1A32A	MCC Area El. 166' Zone 2-8 (1A410)		
SP64-TS-N1A32B	MCC Area El. 166' Zone 2-8 (1A410)		
SP65-XS-N533E	Storage Area El. 185' Zone 2-9 (1A519)	Any One	Produces An Alarm
SP65-XS-N533F	Storage Area El. 185' Zone 2-9 (1A519)		
SP65-XS-N533G	Storage Area El. 185' Zone 2-9 (1A519)		
SP65-XS-N533H	Storage Area El. 185' Zone 2-9 (1A519)		
SP65-XS-N533A	Load Center Area El. 185' Zone 2-9 (1A527)		
SP65-XS-N533B	Load Center Area El. 185' Zone 2-9 (1A527)		
SP65-XS-N533C	Load Center Area El. 185' Zone 2-9 (1A527)		
SP65-XS-N533D	Platform El. 185' Zone 2-9 (1A524)		
SP65-XS-N533J	FPCCU Tank Rm. El. 185' Zone 2-9 (1A529)		
SP65-XS-N533I	Load Center Area El. 185'/Platform El. 195' Zone 2-9 (1A527/1A538)		

* One Channel (Typical of 39 shown on this page)

DEFINITIONS FOR
 "CHANNELS", "TRIP SYSTEMS", AND "TRIP FUNCTIONS"
 FOR FIRE DETECTION INSTRUMENTATION TABLE 3.3.7.9-1 (Continued)

<u>Trip Unit</u>	<u>Parameter</u>	<u>Logic</u>	<u>Function</u>
SP65-XS-N600F	Storage Area El. 208' 10" Zone 2-13 (1A602)	}	
SP65-XS-N600G	Storage Area El. 208' 10" Zone 2-13 (1A602)		
SP65-XS-N600H	Storage Area El. 208' 10" Zone 2-13 (1A602)		
SP65-XS-N600I	Storage Area El. 208' 10" Zone 2-13 (1A602)		
SP65-XS-N600T	Storage Area El. 208' 10" Zone 2-13 (1A602)		
SP65-XS-N600U	Storage Area El. 208' 10" Zone 2-13 (1A602)		
SP65-XS-N600C	Passage El. 208' 10" Zone 2-13 (1A603)		
SP65-XS-N600D	Passage El. 208' 10" Zone 2-13 (1A603)		
SP65-XS-N600E	Passage El. 208' 10" Zone 2-13 (1A603)		
SP65-XS-N600A	Fuel Handling Area El. 208' 10" Zone 2-13 (1A604)		
SP65-XS-N600B	Fuel Handling Area El. 208' 10" Zone 2-13 (1A604)		
SP65-XS-N600J	*Fuel Handling Area El. 208' 10" Zone 2-13 (1A604)		
SP65-XS-N600K	Fuel Handling Area El. 208' 10" Zone 2-13 (1A604)		
SP65-XS-N600L	Fuel Handling Area El. 208' 10" Zone 2-13 (1A604)		
SP65-XS-N600M	Fuel Handling Area El. 208' 10" Zone 2-13 (1A604)		
SP65-XS-N600N	Fuel Handling Area El. 208' 10" Zone 2-13 (1A604)		
SP65-XS-N600O	Fuel Handling Area El. 208' 10" Zone 2-13 (1A604)		
SP65-XS-N600P	Fuel Handling Area El. 208' 10" Zone 2-13 (1A604)		
SP65-XS-N600Q	Fuel Handling Area El. 208' 10" Zone 2-13 (1A604)		
SP65-XS-N600R	Fuel Handling Area El. 208' 10" Zone 2-13 (1A604)		
SP65-XS-N600S	Fuel Handling Area El. 208' 10" Zone 2-13 (1A604)		
SP65-XS-N600V	Fuel Handling Area El. 208' 10" Zone 2-13 (1A604)		
SP65-XS-N600W	HVAC Equip Area El. 245' Zone 2-13 (1A606)		
SP65-XS-N600X	HVAC Equip Area El. 245' Zone 2-13 (1A606)		
SP65-XS-N600Y	HVAC Equip Area El. 245' Zone 2-13 (1A606)		
SP65-XS-N600Z	HVAC Equip Area El. 245' Zone 2-13 (1A606)		
SP65-XS-N600AA	HVAC Equip Area El. 245' Zone 2-13 (1A606)		
SP65-XS-N600BB	HVAC Equip Area El. 245' Zone 2-13 (1A606)		
SP65-XS-N600CC	HVAC Equip Area El. 245' Zone 2-13 (1A606)		
SP65-XS-N600DD	HVAC Equip Area El. 245' Zone 2-13 (1A606)		
SP65-XS-N600EE	HVAC Equip Area El. 245' Zone 2-13 (1A606)		

Any — Produces
 One — An Alarm

* One Channel (Typical of 31 shown on this page)

DEFINITIONS FOR
 "CHANNELS", "TRIP SYSTEMS", AND "TRIP FUNCTIONS"
 FOR FIRE DETECTION INSTRUMENTATION TABLE 3.3.7.9-1 (Continued)

<u>Trip Unit</u>	<u>Parameter</u>	<u>Logic</u>	<u>Function</u>
SP65-XS-N601A	Corridor Zone 2-14 (1A122)	Any One	Produces An Alarm
SP65-XS-N601B	Fan Coil Area/South Corridor El. 93'/103' Zone 2-14 (1A114/1A122)		
SP65-XS-N601C	Fan Coil Area/South Corridor El. 93'/103' Zone 2-14 (1A114/1A122)		
SP65-XS-N601D	Fan Coil Area/South Corridor El. 93'/103' Zone 2-14 (1A114/1A122)		
SP65-XS-N626D	Piping Penetration Rm El. 93' Zone 2-14 (1A115)		
SP65-XS-N626A	*Piping Pen Rm El. 93' Zone 2-14 (1A116)		
SP65-XS-N601H	Misc Equip Area/North Corridor El. 93'/103' Zone 2-14 (1A117/1A123)		
SP65-XS-N601I	Misc Equip Area/North Corridor El. 93'/103' Zone 2-14 (1A117/1A123)		
SP65-XS-N601J	Misc Equip Area/North Corridor El. 93'/103' Zone 2-14 (1A117/1A123)		
SP65-XS-N601K	Misc Equip Area/North Corridor El. 93'/103' Zone 2-14 (1A117/1A123)		
SP65-XS-N626B	RHR "C" Pump Room EL. 93' Zone 2-14 (1A118)		
SP65-XS-N626C	RHR "C" Pump Room EL. 93' Zone 2-14 (1A118)		
SP65-XS-N626E	LPCS Pump Room El. 93' Zone 2-14 (1A119)		
SP65-XS-N626F	LPCS Pump Room El. 93' Zone 2-14 (1A119)		
SP65-XS-N601E	CCW Pump & Hx Area El. 93' Zone 2-14 (1A120)		
SP65-XS-N601F	CCW Pump & Hx Area El. 93' Zone 2-14 (1A120)		
SP65-XS-N601G	CCW Pump & Hx Area El. 93' Zone 2-14 (1A120)		
SP65-XS-N623	Cable Chase El. 185' Zone 2-15 (1A539)	Produces An Alarm	

* One Channel (Typical of 18 shown on this page)

DEFINITIONS FOR
 "CHANNELS", "TRIP SYSTEMS", AND "TRIP FUNCTIONS"
 FOR FIRE DETECTION INSTRUMENTATION TABLE 3.3.7.9-1 (Continued)

<u>Trip Unit</u>	<u>Parameter</u>	<u>Logic</u>	<u>Function</u>
SP65-XS-N625A	HPCS Pump Room El. 93' Zone 2-17 (1A109)	Any One	Produces An Alarm
SP65-XS-N625B	HPCS Pump Room El. 93' Zone 2-17 (1A109)		
SP65-XS-N602D	Passage/East Corridor El. 93'/103' Zone 2-17 (1A101/1A121)		
SP65-XS-N602E	*Passage/East Corridor El. 93'/103' Zone 2-17 (1A101/1A121)		
SP65-XS-N602F	Passage/East Corridor El. 93'/103' Zone 2-17 (1A101/1A121)		
SP65-XS-N602G	Passage/East Corridor El. 93'/103' Zone 2-17 (1A101/1A121)		
SP65-XS-N602H	Passage/East Corridor El. 93'/103' Zone 2-17 (1A101/1A121)		
SP65-XS-N602N	Piping Penetration Rm El. 93' Zone 2-17 (1A111)		
SP65-XS-N602A	Fan Coil Area/South Corridor El. 93'/103' Zone 2-17 (1A114/1A122)		
SP65-XS-N602B	Fan Coil Area/South Corridor El. 93'/103' Zone 2-17 (1A114/1A122)		
SP65-XS-N602C	Fan Coil Area/South Corridor El. 93'/103' Zone 2-17 (1A114/1A122)		
SP65-XS-N602I	Misc. Eq. Area/North Corridor El. 93'/103' Zone 2-17 (1A117/1A123)		
SP65-XS-N602J	Misc. Eq. Area/North Corridor El. 93'/103' Zone 2-17 (1A117/1A123)		
SP65-XS-N602K	Misc. Eq. Area/North Corridor El. 93'/103' Zone 2-17 (1A117/1A123)		
SP65-XS-N602L	Misc. Eq. Area/North Corridor El. 93'/103' Zone 2-17 (1A117/1A123)		
SP65-XS-N602M	Misc Eq. Area/North Corridor El. 93'/103' Zone 2-17 (1A117/1A123)		

* One Channel (Typical of 16 shown on this page)

DEFINITIONS FOR
"CHANNELS", "TRIP SYSTEMS", AND "TRIP FUNCTIONS"
FOR FIRE DETECTION INSTRUMENTATION TABLE 3.3.7.9-1 (Continued)

<u>Trip Unit</u>	<u>Parameter</u>	<u>Logic</u>	<u>Function</u>		
SP65-XS-N603A	East Corridor El. 119' Zone 2-18 (1A215)	}			
SP65-XS-N603B	East Corridor El. 119' Zone 2-18 (1A201)				
SP65-XS-N603C	East Corridor El. 119' Zone 2-18 (1A201)				
SP65-XS-N603D	East Corridor El. 119' Zone 2-18 (1A201)				
SP65-XS-N603E	East Corridor El. 119' Zone 2-18 (1A201)				
SP65-XS-N603F	East Corridor El. 119' Zone 2-18 (1A201)				
SP65-XS-N705A	North Corridor El. 119' Zone 2-18 (1A211)				
SP65-XS-N705B	North Corridor El. 119' Zone 2-18 (1A211)				
SP65-XS-N705C	North Corridor El. 119' Zone 2-18 (1A211)				
SP65-XS-N705D	North Corridor El. 119' Zone 2-18 (1A211)				
SP65-XS-N705E	North Corridor El. 119' Zone 2-18 (1A211)				
SP65-XS-N705F	*North Corridor El. 119' Zone 2-18 (1A211)			Any	Produces An Alarm
SP65-XS-N705G	North Corridor El. 119' Zone 2-18 (1A211)			}	
SP65-XS-N705H	North Corridor El. 119' Zone 2-18 (1A211)				
SP65-XS-N603G	North Corridor El. 119' Zone 2-18 (1A211)				
SP65-XS-N603H	North Corridor El. 119' Zone 2-18 (1A211)				
SP65-XS-N603I	North Corridor El. 119' Zone 2-18 (1A211)				
SP65-XS-N603J	North Corridor El. 119' Zone 2-18 (1A211)				
SP65-XS-N603K	North Corridor El. 119' Zone 2-18 (1A211)				
SP65-XS-N603L	North Corridor El. 119' Zone 2-18 (1A211)				
SP65-XS-N604A	South Corridor El. 139' Zone 2-19 (1A314)				
SP65-XS-N604B	South Corridor El. 139' Zone 2-19 (1A314)				
SP65-XS-N604C	South Corridor El. 139' Zone 2-19 (1A314)				
SP65-XS-N604H	MCC Area El. 139' Zone 2-19 (1A321)				
SP65-XS-N604L	North Corridor El. 139' Zone 2-19 (1A316)				
SP65-XS-N604K	MCC Area El. 139' Zone 2-19 (1A321)				
SP65-XS-N604D	Centrifugal Chiller Area El 139' Zone 2-19 (1A322)	}			
SP65-XS-N604E	Centrifugal Chiller Area El 139' Zone 2-19 (1A322)			Any	Produces An Alarm
SP65-XS-N604F	Centrifugal Chiller Area El 139' Zone 2-19 (1A322)				
SP65-XS-N604G	Centrifugal Chiller Area El 139' Zone 2-19 (1A322)				
SP65-XS-N604I	SGTS Area El. 139' Zone 2-19 (1A323)				
SP65-XS-N604M	HVAC Equip Area El. 139' Zone 2-19 (1A324)	}			
SP65-XS-N604J	SGTS Area El. 139' Zone 2-19 (1A326)				
SP65-XS-N605A	Steam Tunnel El. 139' Zone 2-20 (1A305)			Any	Produces An Alarm
SP65-XS-N605B	Steam Tunnel El. 139' Zone 2-20 (1A305)	One	Alarm		

* One Channel (Typical of 35 shown on this page)

DEFINITIONS FOR
"CHANNELS", "TRIP SYSTEMS", AND "TRIP FUNCTIONS"
FOR FIRE DETECTION INSTRUMENTATION TABLE 3.3.7.9-1 (Continued)

<u>Trip Unit</u>	<u>Parameter</u>	<u>Logic</u>	<u>Function</u>
<u>Diesel Generator Building</u>			
SP64-TS-N1A10H	Dsl. Gen. Bldg. Corridor El. 133' Zone 2-10 (1D301)	Any One	Produces An Alarm & Opens the Deluge Vlv.
SP64-TS-N1A10I	Dsl. Gen. Bldg. Corridor El. 133' Zone 2-10 (1D301)		
SP64-TS-N1A10J	Dsl. Gen. Bldg. Corridor El. 133' Zone 2-10 (1D301)		
SP65-XS-N534A	Dsl. Gen. Bldg. Corridor El. 133' Zone 2-10 (1D301)	Any One	Produces An Alarm
SP65-XS-N534B	Dsl. Gen. Bldg. Corridor El. 133' Zone 2-10 (1D301)		
SP65-XS-N534C	Dsl. Gen. Bldg. Corridor El. 133' Zone 2-10 (1D301)		
SP64-TS-N1C10A	Unit 1 El. 133'-0" HPCS Gen Zone 2-10 (1D306)	Any One	Produces An Alarm & Opens the Deluge Vlv
SP64-TS-N1C10B	Unit 1 El. 133'-0" HPCS Gen Zone 2-10 (1D306)		
SP64-TS-N1C10C	Unit 1 El. 133'-0" HPCS Gen Zone 2-10 (1D306)		
SP64-TS-N1C10D	Unit 1 El. 133'-0" HPCS Gen Zone 2-10 (1D306)		
SP64-TS-N1C10E	Unit 1 El. 133'-0" HPCS Gen Zone 2-10 (1D306)		
SP64-TS-N1C10F	Unit 1 El. 133'-0" HPCS Gen Zone 2-10 (1D306)		
SP64-TS-N1C10G	Unit 1 El. 133'-0" HPCS Gen Zone 2-10 (1D306)		
SP65-FD-N800A	Unit 1 El. 133'-0" HPCS Gen Zone 2-10 (1D306)		
SP65-FD-N800B	Unit 1 El. 158'-0" HPCS Gen Zone 2-10 (1D401)	Any One	Produces An Alarm
SP65-FD-N800C	Unit 1 El. 133'-0" HPCS Gen Zone 2-10 (1D304)		
SP65-FD-N800D	Unit 1 El. 133'-0" HPCS Gen Zone 2-10 (1D306)		
SP65-FD-N800E	Unit 1 El. 158'-0" HPCS Gen Zone 2-10 (1D401)		
SP65-FD-N800F	Unit 1 El. 133'-0" HPCS Gen Zone 2-10 (1D306)		
SP64-TS-N1B10A	Unit 1 El. 133'-0" Bus B Gen Zone 2-11 (1D308)		
SP64-TS-N1B10B	Unit 1 El. 133'-0" Bus B Gen Zone 2-11 (1D308)	Any One	Produces An Alarm & Opens the Deluge Vlv
SP64-TS-N1B10C	*Unit 1 El. 133'-0" Bus B Gen Zone 2-11 (1D308)		
SP64-TS-N1B10D	Unit 1 El. 133'-0" Bus B Gen Zone 2-11 (1D308)		
SP64-TS-N1B10E	Unit 1 El. 133'-0" Bus B Gen Zone 2-11 (1D308)		
SP64-TS-N1B10F	Unit 1 El. 133'-0" Bus B Gen Zone 2-11 (1D308)		
SP64-TS-N1B10G	Unit 1 El. 133'-0" Bus B Gen Zone 2-11 (1D308)		
SP65-FD-N801A	Unit 1 El. 133'-0" Bus B Gen Zone 2-11 (1D308)		
SP65-FD-N801B	Unit 1 El. 158'-0" Bus B Gen Zone 2-11 (1D402)	Any One	Produces An Alarm
SP65-FD-N801C	Unit 1 El. 133'-0" Bus B Gen Zone 2-11 (1D303)		
SP65-FD-N801D	Unit 1 El. 133'-0" Bus B Gen Zone 2-11 (1D308)		
SP65-FD-N801E	Unit 1 El. 133'-0" Bus B Gen Zone 2-11 (1D402)		
SP65-FD-N801F	Unit 1 El. 133'-0" Bus B Gen Zone 2-11 (1D308)		

* One Channel (Typical of 32 shown on this page)

DEFINITIONS FOR
 "CHANNELS", "TRIP SYSTEMS", AND "TRIP FUNCTIONS"
 FOR FIRE DETECTION INSTRUMENTATION TABLE 3.3.7.9-1 (Continued)

<u>Trip Unit</u>	<u>Parameter</u>	<u>Logic</u>	<u>Function</u>
SP64-TS-N1A10A	Unit 1 El. 133'-0" Bus A Gen Zone 2-12 (1D310)	Any One	Produces An Alarm & Opens the Deluge Vlv
SP64-TS-N1A10B	Unit 1 El. 133'-0" Bus A Gen Zone 2-12 (1D310)		
SP64-TS-N1A10C	Unit 1 El. 133'-0" Bus A Gen Zone 2-12 (1D310)		
SP64-TS-N1A10D	Unit 1 El. 133'-0" Bus A Gen Zone 2-12 (1D310)		
SP64-TS-N1A10E	Unit 1 El. 133'-0" Bus A Gen Zone 2-12 (1D310)		
SP64-TS-N1A10F	Unit 1 El. 133'-0" Bus A Gen Zone 2-12 (1D310)		
SP64-TS-N1A10G	*Unit 1 El. 133'-0" Bus A Gen Zone 2-12 (1D310)		
SP65-FD-N802A	Unit 1 El. 133'-0" Bus A Gen Zone 2-12 (1D310)	Any One	Produces An Alarm
SP65-FD-N802B	Unit 1 El. 158'-0" Bus A Gen Zone 2-12 (1D403)		
SP65-FD-N802C	Unit 1 El. 133'-0" Bus A Gen Zone 2-12 (1D302)		
SP65-FD-N802D	Unit 1 El. 133'-0" Bus A Gen Zone 2-12 (1D310)		
SP65-FD-N802E	Unit 1 El. 158'-0" Bus A Gen Zone 2-12 (1D403)		
SP65-FD-N802F	Unit 1 El. 133'-0" Bus A Gen Zone 2-12 (1D310)		

* One Channel (Typical of 13 shown on this page)

DEFINITIONS FOR
 "CHANNELS", "TRIP SYSTEMS", AND "TRIP FUNCTIONS"
 FOR FIRE DETECTION INSTRUMENTATION TABLE 3.3.7.9-1 (Continued)

<u>Trip Unit</u>	<u>Parameter</u>	<u>Logic</u>	<u>Function</u>
<u>Standby Service Water Pump House</u>			
SP65-XS-N547A	Pump House A Zone 2-1 (1M110)]-----	Any One ----- Produces An Alarm
SP65-XS-N547B	*Valve Room A Zone 2-1 (1M112)		
SP65-XS-N582A	Pump House B Zone 2-1 (2M110)		
SP65-XS-N582B	Valve Room B Zone 2-1 (2M112)		
<u>Charcoal Filter Trains</u>			
1T48-TE-N009A	SGTS Filter Train A Aux Bldg El 139'-0"]-----	Produces an Alarm and Stops the Fan
1T48-TE-N009B	SGTS Filter Train B Aux Bldg El 139'-0"]-----	Produces an Alarm and Stops the Fan
SZ51-TE-N020A	Control Room Standby Fresh Air Sys Fltr Train A Control Bldg El. 133'-0"]-----	Produces an Alarm and Stops the Fan
SZ51-TE-N020B	Control Room Standby Fresh Air Fltr Train B Control Bldg El. 133'-0"]-----	Produces an Alarm and Stops the Fan

* One Channel (Typical of 8 shown on this page)

NOTE: Trip Units "XS" Represent Smoke Detectors (except SP64-XS-N400A-H, and J-M which are heat detectors)
 Trip Units "TS" Represent Heat Detectors
 Trip Units "FD" Represent Flame Detectors
 Trip Units "TE" Represent Temperature Sensors

DEFINITIONS FOR
 "CHANNELS", "TRIP SYSTEMS", AND "TRIP FUNCTIONS"
 FOR FIRE DETECTION INSTRUMENTATION TABLE 3.3.7.9-1 (Continued)

<u>Detector</u>	<u>Parameter</u>	<u>Logic</u>	<u>Function</u>	
S01 (TS)	1H13-U700 (Control Room OC503 El. 166')	} Any One	Produces An Alarm, Disch. Halon	
S02 (TS)	1H13-U700 (Control Room OC503 El. 166')			
S03 (TS)	*1H13-U700 (Control Room OC503 El. 166')			
S04 (TS)	1H13-U700 (Control Room OC503 El. 166')			
S05 (TS)	1H13-U700 (Control Room OC503 El. 166')			
S06 (TS)	1H13-U700 (Control Room OC503 El. 166')			
S07 (TS)	1H13-U700 (Control Room OC503 El. 166')			
S08 (TS)	1H13-U700 (Control Room OC503 El. 166')			
S09 (TS)	1H13-U700 (Control Room OC503 El. 166')			
S10 (TS)	1H13-U700 (Control Room OC503 El. 166')			
S13 (POC)	1H13-U700 (Control Room OC503 El. 166')		} Any One	Produces An Alarm
S14 (POC)	1H13-U700 (Control Room OC503 El. 166')			
S15 (POC)	1H13-U700 (Control Room OC503 El. 166')			
S16 (POC)	1H13-U700 (Control Room OC503 El. 166')			
S17 (POC)	1H13-U700 (Control Room OC503 El. 166')			
S18 (POC)	1H13-U700 (Control Room OC503 El. 166')			
S19 (POC)	1H13-U700 (Control Room OC503 El. 166')			
S20 (POC)	1H13-U700 (Control Room OC503 El. 166')			
S21 (POC)	1H13-U700 (Control Room OC503 El. 166')			
S22 (POC)	1H13-U700 (Control Room OC503 El. 166')			

(TS) Represents thermal detectors
 (POC) Represents products of combustion detectors
 * One Channel (Typical of 20 shown on this page)

DEFINITIONS FOR
 "CHANNELS", "TRIP SYSTEMS", AND "TRIP FUNCTIONS"
 FOR FIRE DETECTION INSTRUMENTATION TABLE 3.3.7.9-1 (Continued)

<u>Detector</u>	<u>Parameter</u>	<u>Logic</u>	<u>Function</u>
S01 (TS)	1H13-U701 (Control Room OC503 El. 166')	Any One	Produces An Alarm, Disch. Halon
S02 (TS)	1H13-U701 (Control Room OC503 El. 166')		
S03 (TS)	1H13-U701 (Control Room OC503 El. 166')		
S04 (TS)	*1H13-U701 (Control Room OC503 El. 166')		
S05 (TS)	1H13-U701 (Control Room OC503 El. 166')		
S06 (TS)	1H13-U701 (Control Room OC503 El. 166')		
S07 (TS)	1H13-U701 (Control Room OC503 El. 166')		
S08 (TS)	1H13-U701 (Control Room OC503 El. 166')		
S09 (TS)	1H13-U701 (Control Room OC503 El. 166')		
S10 (TS)	1H13-U701 (Control Room OC503 El. 166')		
S13 (POC)	1H13-U701 (Control Room OC503 El. 166')	Any One	Produces An Alarm
S14 (POC)	1H13-U701 (Control Room OC503 El. 166')		
S15 (POC)	1H13-U701 (Control Room OC503 El. 166')		
S16 (POC)	1H13-U701 (Control Room OC503 El. 166')		
S17 (POC)	1H13-U701 (Control Room OC503 El. 166')		
S25 (POC)	1H13-U701 (Control Room OC503 El. 166')		
S26 (POC)	1H13-U701 (Control Room OC503 El. 166')		
S27 (POC)	1H13-U701 (Control Room OC503 El. 166')		
S28 (POC)	1H13-U701 (Control Room OC503 El. 166')		
S29 (POC)	1H13-U701 (Control Room OC503 El. 166')		
S30 (POC)	1H13-U701 (Control Room OC503 El. 166')		
S31 (POC)	1H13-U701 (Control Room OC503 El. 166')		
S32 (POC)	1H13-U701 (Control Room OC503 El. 166')		
S33 (POC)	1H13-U701 (Control Room OC503 El. 166')		
S34 (POC)	1H13-U701 (Control Room OC503 El. 166')		

(TS) Represents thermal detectors

(POC) Represents products of combustion detectors

* One Channel (Typical of 25 shown on this page)

DEFINITIONS FOR
 "CHANNELS", "TRIP SYSTEMS", AND "TRIP FUNCTIONS"
 FOR FIRE DETECTION INSTRUMENTATION TABLE 3.3.7.9-1 (Continued)

<u>Detector</u>	<u>Parameter</u>	<u>Logic</u>	<u>Function</u>
S01 (TS)	1H13-U702 (Control Room OC503 El. 166')	Any One	Produces An Alarm, Disch. Halon
S02 (TS)	1H13-U702 (Control Room OC503 El. 166')		
S03 (TS)	1H13-U702 (Control Room OC503 El. 166')		
S04 (TS)	*1H13-U702 (Control Room OC503 El. 166')		
S40 (TS)	1H13-U702 (Control Room OC503 El. 166')		
S41 (TS)	1H13-U702 (Control Room OC503 El. 166')		
S42 (TS)	1H13-U702 (Control Room OC503 El. 166')		
S43 (TS)	1H13-U702 (Control Room OC503 El. 166')		
S44 (TS)	1H13-U702 (Control Room OC503 El. 166')		
S13 (POC)	1H13-U702 (Control Room OC503 El. 166')		
S14 (POC)	1H13-U702 (Control Room OC503 El. 166')		
S15 (POC)	1H13-U702 (Control Room OC503 El. 166')		
S16 (POC)	1H13-U702 (Control Room OC503 El. 166')		
S25 (POC)	1H13-U702 (Control Room OC503 El. 166')		
S26 (POC)	1H13-U702 (Control Room OC503 El. 166')		
S27 (POC)	1H13-U702 (Control Room OC503 El. 166')		
S28 (POC)	1H13-U702 (Control Room OC503 El. 166')		
S30 (POC)	1H13-U702 (Control Room OC503 El. 166')		
S50 (POC)	1H13-U702 (Control Room OC503 El. 166')		
S51 (POC)	1H13-U702 (Control Room OC503 El. 166')		
S52 (POC)	1H13-U702 (Control Room OC503 El. 166')		
S53 (POC)	1H13-U702 (Control Room OC503 El. 166')		
S54 (POC)	1H13-U702 (Control Room OC503 El. 166')		

(TS) Represents thermal detectors
 (POC) Represents products of combustion detectors
 * One Channel (Typical of 23 shown on this page)

DEFINITIONS FOR
 "CHANNELS", "TRIP SYSTEMS", AND "TRIP FUNCTIONS"
 FOR FIRE DETECTION INSTRUMENTATION TABLE 3.3.7.9-1 (Continued)

<u>Detector</u>	<u>Parameter</u>	<u>Logic</u>	<u>Function</u>
S01 (TS)	1H13-U703 (Control Room OC503 El. 166')	Any One	Produces An Alarm, Disch. Halon
S02 (TS)	1H13-U703 (Control Room OC503 El. 166')		
S03 (TS)	1H13-U703 (Control Room OC503 El. 166')		
S04 (TS)	*1H13-U703 (Control Room OC503 El. 166')		
S05 (TS)	1H13-U703 (Control Room OC503 El. 166')		
S06 (TS)	1H13-U703 (Control Room OC503 El. 166')		
S07 (TS)	1H13-U703 (Control Room OC503 El. 166')		
S08 (TS)	1H13-U703 (Control Room OC503 El. 166')		
S09 (TS)	1H13-U703 (Control Room OC503 El. 166')		
S10 (TS)	1H13-U703 (Control Room OC503 El. 166')		
S11 (TS)	1H13-U703 (Control Room OC503 El. 166')		
S13 (POC)	1H13-U703 (Control Room OC503 El. 166')	Any One	Produces An Alarm
S14 (POC)	1H13-U703 (Control Room OC503 El. 166')		
S15 (POC)	1H13-U703 (Control Room OC503 El. 166')		
S16 (POC)	1H13-U703 (Control Room OC503 El. 166')		
S17 (POC)	1H13-U703 (Control Room OC503 El. 166')		
S18 (POC)	1H13-U703 (Control Room OC503 El. 166')		
S19 (POC)	1H13-U703 (Control Room OC503 El. 166')		
S20 (POC)	1H13-U703 (Control Room OC503 El. 166')		
S21 (POC)	1H13-U703 (Control Room OC503 El. 166')		
S22 (POC)	1H13-U703 (Control Room OC503 El. 166')		
S23 (POC)	1H13-U703 (Control Room OC503 El. 166')		
S25 (POC)	1H13-U703 (Control Room OC503 El. 166')		
S26 (POC)	1H13-U703 (Control Room OC503 El. 166')		
S27 (POC)	1H13-U703 (Control Room OC503 El. 166')		
S28 (POC)	1H13-U703 (Control Room OC503 El. 166')		
S29 (POC)	1H13-U703 (Control Room OC503 El. 166')		
S30 (POC)	1H13-U703 (Control Room OC503 El. 166')		

(TS) Represents thermal detectors
 (POC) Represents products of combustion detectors
 * One Channel (Typical of 28 shown on this page)

DEFINITIONS FOR
 "CHANNELS", "TRIP SYSTEMS", AND "TRIP FUNCTIONS"
 FOR FIRE DETECTION INSTRUMENTATION TABLE 3.3.7.9-1 (Continued)

Detector	Parameter	Logic	Function
S01 (TS)	1H13-U720 (Control Room OC503 El. 166')	Any One	Produces An Alarm, Disch. Halon
S02 (TS)	1H13-U720 (Control Room OC503 El. 166')		
S03 (TS)	1H13-U720 (Control Room OC503 El. 166')		
S04 (TS)	*1H13-U720 (Control Room OC503 El. 166')		
S40 (TS)	1H13-U720 (Control Room OC503 El. 166')		
S41 (TS)	1H13-U720 (Control Room OC503 El. 166')		
S42 (TS)	1H13-U720 (Control Room OC503 El. 166')		
S13 (POC)	1H13-U720 (Control Room OC503 El. 166')		
S14 (POC)	1H13-U720 (Control Room OC503 El. 166')		
S15 (POC)	1H13-U720 (Control Room OC503 El. 166')		
S16 (POC)	1H13-U720 (Control Room OC503 El. 166')	Any One	Produces An Alarm
S25 (POC)	1H13-U720 (Control Room OC503 El. 166')		
S26 (POC)	1H13-U720 (Control Room OC503 El. 166')		
S27 (POC)	1H13-U720 (Control Room OC503 El. 166')		
S28 (POC)	1H13-U720 (Control Room OC503 El. 166')		
S29 (POC)	1H13-U720 (Control Room OC503 El. 166')		
S30 (POC)	1H13-U720 (Control Room OC503 El. 166')		
S50 (POC)	1H13-U720 (Control Room OC503 El. 166')		
S51 (POC)	1H13-U720 (Control Room OC503 El. 166')		
S52 (POC)	1H13-U720 (Control Room OC503 El. 166')		

(TS) Represents thermal detectors
 (POC) Represents products of combustion detectors
 * One Channel (Typical of 20 shown on this page)

DEFINITIONS FOR
 "CHANNELS", "TRIP SYSTEMS", AND "TRIP FUNCTIONS"
 FOR FIRE DETECTION INSTRUMENTATION TABLE 3.3.7.9-1 (Continued)

<u>Detector</u>	<u>Parameter</u>	<u>Logic</u>	<u>Function</u>
S01 (TS)	SH13-U730 (Control Room OC503 El. 166')	Any One	Produces An Alarm, Disch. Halon
S02 (TS)	SH13-U730 (Control Room OC503 El. 166')		
S03 (TS)	SH13-U730 (Control Room OC503 El. 166')		
S04 (TS)	*SH13-U730 (Control Room OC503 El. 166')		
S05 (TS)	SH13-U730 (Control Room OC503 El. 166')		
S06 (TS)	SH13-U730 (Control Room OC503 El. 166')		
S07 (TS)	SH13-U730 (Control Room OC503 El. 166')		
S08 (TS)	SH13-U730 (Control Room OC503 El. 166')		
S09 (TS)	SH13-U730 (Control Room OC503 El. 166')		
S10 (TS)	SH13-U730 (Control Room OC503 El. 166')		
S40 (TS)	SH13-U730 (Control Room OC503 El. 166')	Any One	Produces An Alarm
S13 (POC)	SH13-U730 (Control Room OC503 El. 166')		
S14 (POC)	SH13-U730 (Control Room OC503 El. 166')		
S15 (POC)	SH13-U730 (Control Room OC503 El. 166')		
S16 (POC)	SH13-U730 (Control Room OC503 El. 166')		
S17 (POC)	SH13-U730 (Control Room OC503 El. 166')		
S25 (POC)	SH13-U730 (Control Room OC503 El. 166')		
S26 (POC)	SH13-U730 (Control Room OC503 El. 166')		
S27 (POC)	SH13-U730 (Control Room OC503 El. 166')		
S28 (POC)	SH13-U730 (Control Room OC503 El. 166')		
S29 (POC)	SH13-U730 (Control Room OC503 El. 166')		
S30 (POC)	SH13-U730 (Control Room OC503 El. 166')		
S50 (POC)	SH13-U730 (Control Room OC503 El. 166')		

(TS) Represents thermal detectors
 (POC) Represents products of combustion detectors
 * One Channel (Typical of 23 shown on this page)

DEFINITIONS FOR
"CHANNELS", "TRIP SYSTEMS", AND "TRIP FUNCTIONS"
FOR FIRE DETECTION INSTRUMENTATION TABLE 3.3.7.9-1 (Continued)

<u>Detector</u>	<u>Parameter</u>	<u>Logic</u>	<u>Function</u>
S01 (TS)	1H13-U738 (Control Room OC503 El. 166')	Any One	Produces An Alarm, Disch. Halon
S02 (TS)	1H13-U738 (Control Room OC503 El. 166')		
S03 (TS)	1H13-U738 (Control Room OC503 El. 166')		
S04 (TS)	*1H13-U738 (Control Room OC503 El. 166')		
S05 (TS)	1H13-U738 (Control Room OC503 El. 166')		
S06 (TS)	1H13-U738 (Control Room OC503 El. 166')		
S07 (TS)	1H13-U738 (Control Room OC503 El. 166')		
S08 (TS)	1H13-U738 (Control Room OC503 El. 166')		
S09 (TS)	1H13-U738 (Control Room OC503 El. 166')		
S10 (TS)	1H13-U738 (Control Room OC503 El. 166')		
S13 (POC)	1H13-U738 (Control Room OC503 El. 166')	Any One	Produces An Alarm
S14 (POC)	1H13-U738 (Control Room OC503 El. 166')		
S15 (POC)	1H13-U738 (Control Room OC503 El. 166')		
S16 (POC)	1H13-U738 (Control Room OC503 El. 166')		
S17 (POC)	1H13-U738 (Control Room OC503 El. 166')		
S25 (POC)	1H13-U738 (Control Room OC503 El. 166')		
S26 (POC)	1H13-U738 (Control Room OC503 El. 166')		
S27 (POC)	1H13-U738 (Control Room OC503 El. 166')		
S28 (POC)	1H13-U738 (Control Room OC503 El. 166')		
S29 (POC)	1H13-U738 (Control Room OC503 El. 166')		
S30 (POC)	1H13-U738 (Control Room OC503 El. 166')		
S32 (POC)	1H13-U738 (Control Room OC503 El. 166')		

(TS) Represents thermal detectors

(POC) Represents products of combustion detectors

* One Channel (Typical of 22 shown on this page)

DEFINITIONS FOR
 "CHANNELS", "TRIP SYSTEMS", AND "TRIP FUNCTIONS"
 FOR FIRE DETECTION INSTRUMENTATION TABLE 3.3.7.9-1 (Continued)

<u>Detector</u>	<u>Parameter</u>	<u>Logic</u>	<u>Function</u>
S01 (TS)	SH13-U739 (Control Room OC503 El. 166')	Any One	Produces An Alarm, Disch. Halon
S02 (TS)	SH13-U739 (Control Room OC503 El. 166')		
S03 (TS)	SH13-U739 (Control Room OC503 El. 166')		
S04 (TS)	*SH13-U739 (Control Room OC503 El. 166')		
S40 (TS)	SH13-U739 (Control Room OC503 El. 166')	Any One	Produces An Alarm
S13 (POC)	SH13-U739 (Control Room OC503 El. 166')		
S14 (POC)	SH13-U739 (Control Room OC503 El. 166')		
S15 (POC)	SH13-U739 (Control Room OC503 El. 166')		
S16 (POC)	SH13-U739 (Control Room OC503 El. 166')		
S25 (POC)	SH13-U739 (Control Room OC503 El. 166')		
S26 (POC)	SH13-U739 (Control Room OC503 El. 166')		
S27 (POC)	SH13-U739 (Control Room OC503 El. 166')		
S28 (POC)	SH13-U739 (Control Room OC503 El. 166')		
S29 (POC)	SH13-U739 (Control Room OC503 El. 166')		
S30 (POC)	SH13-U739 (Control Room OC503 El. 166')		
S31 (POC)	SH13-U739 (Control Room OC503 El. 166')		
S32 (POC)	SH13-U739 (Control Room OC503 El. 166')		
S34 (POC)	SH13-U739 (Control Room OC503 El. 166')		
S50 (POC)	SH13-U739 (Control Room OC503 El. 166')		

(TS) Represents thermal detectors
 (POC) Represents products of combustion detectors
 * One Channel (Typical of 19 shown on this page)

DEFINITIONS FOR
 "CHANNELS", "TRIP SYSTEMS", AND "TRIP FUNCTIONS"
 FOR FIRE DETECTION INSTRUMENTATION TABLE 3.3.7.9-1 (Continued)

<u>Detector</u>	<u>Parameter</u>	<u>Logic</u>	<u>Function</u>		
S03 (TS)	1H13-U710 (Unit 1 Instr. Rack Area OC504 El. 166')	Any One	Produces An Alarm, Disch. Halon		
S04 (TS)	*1H13-U710 (Unit 1 Instr. Rack Area OC504 El. 166')				
S05 (TS)	1H13-U710 (Unit 1 Instr. Rack Area OC504 El. 166')				
S06 (TS)	1H13-U710 (Unit 1 Instr. Rack Area OC504 El. 166')				
S07 (TS)	1H13-U710 (Unit 1 Instr. Rack Area OC504 El. 166')				
S08 (TS)	1H13-U710 (Unit 1 Instr. Rack Area OC504 El. 166')				
S09 (TS)	1H13-U710 (Unit 1 Instr. Rack Area OC504 El. 166')				
S10 (TS)	1H13-U710 (Unit 1 Instr. Rack Area OC504 El. 166')				
S13 (POC)	1H13-U710 (Unit 1 Instr. Rack Area OC504 El. 166')				
S14 (POC)	1H13-U710 (Unit 1 Instr. Rack Area OC504 El. 166')				
S15 (POC)	1H13-U710 (Unit 1 Instr. Rack Area OC504 El. 166')				
S16 (POC)	1H13-U710 (Unit 1 Instr. Rack Area OC504 El. 166')				
S25 (POC)	1H13-U710 (Unit 1 Instr. Rack Area OC504 El. 166')				
S26 (POC)	1H13-U710 (Unit 1 Instr. Rack Area OC504 El. 166')				
S27 (POC)	1H13-U710 (Unit 1 Instr. Rack Area OC504 El. 166')				
S28 (POC)	1H13-U710 (Unit 1 Instr. Rack Area OC504 El. 166')			Any One	Produces An Alarm
S29 (POC)	1H13-U710 (Unit 1 Instr. Rack Area OC504 El. 166')				
S30 (POC)	1H13-U710 (Unit 1 Instr. Rack Area OC504 El. 166')				
S31 (POC)	1H13-U710 (Unit 1 Instr. Rack Area OC504 El. 166')				
S32 (POC)	1H13-U710 (Unit 1 Instr. Rack Area OC504 El. 166')				
S33 (POC)	1H13-U710 (Unit 1 Instr. Rack Area OC504 El. 166')				
S34 (POC)	1H13-U710 (Unit 1 Instr. Rack Area OC504 El. 166')				
S35 (POC)	1H13-U710 (Unit 1 Instr. Rack Area OC504 El. 166')				

(TS) Represents thermal detectors
 (POC) Represents products of combustion detectors
 * One Channel (Typical of 23 shown on this page)

DEFINITIONS FOR
 "CHANNELS", "TRIP SYSTEMS", AND "TRIP FUNCTIONS"
 FOR FIRE DETECTION INSTRUMENTATION TABLE 3.3.7.9-1 (Continued)

<u>Detector</u>	<u>Parameter</u>	<u>Logic</u>	<u>Function</u>		
S03 (TS)	1H13-U711 (Unit 1 Instr. Rack Area OC504 El. 166')	} Any One	Produces An Alarm, Disch Halon		
S04 (TS)	1H13-U711 (Unit 1 Instr. Rack Area OC504 El. 166')				
S05 (TS)	*1H13-U711 (Unit 1 Instr. Rack Area OC504 El. 166')				
S06 (TS)	1H13-U711 (Unit 1 Instr. Rack Area OC504 El. 166')				
S07 (TS)	1H13-U711 (Unit 1 Instr. Rack Area OC504 El. 166')				
S08 (TS)	1H13-U711 (Unit 1 Instr. Rack Area OC504 El. 166')				
S09 (TS)	1H13-U711 (Unit 1 Instr. Rack Area OC504 El. 166')				
S10 (TS)	1H13-U711 (Unit 1 Instr. Rack Area OC504 El. 166')				
S13 (POC)	1H13-U711 (Unit 1 Instr. Rack Area OC504 El. 166')				
S14 (POC)	1H13-U711 (Unit 1 Instr. Rack Area OC504 El. 166')				
S15 (POC)	1H13-U711 (Unit 1 Instr. Rack Area OC504 El. 166')				
S16 (POC)	1H13-U711 (Unit 1 Instr. Rack Area OC504 El. 166')				
S25 (POC)	1H13-U711 (Unit 1 Instr. Rack Area OC504 El. 166')				
S26 (POC)	1H13-U711 (Unit 1 Instr. Rack Area OC504 El. 166')			} Any One	Produces An Alarm
S27 (POC)	1H13-U711 (Unit 1 Instr. Rack Area OC504 El. 166')				
S28 (POC)	1H13-U711 (Unit 1 Instr. Rack Area OC504 El. 166')				
S29 (POC)	1H13-U711 (Unit 1 Instr. Rack Area OC504 El. 166')				
S30 (POC)	1H13-U711 (Unit 1 Instr. Rack Area OC504 El. 166')				
S31 (POC)	1H13-U711 (Unit 1 Instr. Rack Area OC504 El. 166')				
S32 (POC)	1H13-U711 (Unit 1 Instr. Rack Area OC504 El. 166')				
S33 (POC)	1H13-U711 (Unit 1 Instr. Rack Area OC504 El. 166')				
S34 (POC)	1H13-U711 (Unit 1 Instr. Rack Area OC504 El. 166')				

(TS) Represents thermal detectors
 (POC) Represents products of combustion detectors
 * One Channel (Typical of 22 shown on this page)

DEFINITIONS FOR
 "CHANNELS", "TRIP SYSTEMS", AND "TRIP FUNCTIONS"
 FOR FIRE DETECTION INSTRUMENTATION TABLE 3.3.7.9-1 (Continued)

<u>Detector</u>	<u>Parameter</u>	<u>Logic</u>	<u>Function</u>		
S03 (TS)	1H13-U712 (Unit 1 Instr. Rack Area OC504 El. 166')	Any One	Produces An Alarm, Disch. Halon		
S04 (TS)	1H13-U712 (Unit 1 Instr. Rack Area OC504 El. 166')				
S05 (TS)	*1H13-U712 (Unit 1 Instr. Rack Area OC504 El. 166')				
S06 (TS)	1H13-U712 (Unit 1 Instr. Rack Area OC504 El. 166')				
S07 (TS)	1H13-U712 (Unit 1 Instr. Rack Area OC504 El. 166')				
S08 (TS)	1H13-U712 (Unit 1 Instr. Rack Area OC504 El. 166')				
S09 (TS)	1H13-U712 (Unit 1 Instr. Rack Area OC504 El. 166')				
S10 (TS)	1H13-U712 (Unit 1 Instr. Rack Area OC504 El. 166')				
S13 (POC)	1H13-U712 (Unit 1 Instr. Rack Area OC504 El. 166')				
S14 (POC)	1H13-U712 (Unit 1 Instr. Rack Area OC504 El. 166')				
S15 (POC)	1H13-U712 (Unit 1 Instr. Rack Area OC504 El. 166')				
S16 (POC)	1H13-U712 (Unit 1 Instr. Rack Area OC504 El. 166')			Any One	Produces An Alarm
S25 (POC)	1H13-U712 (Unit 1 Instr. Rack Area OC504 El. 166')				
S26 (POC)	1H13-U712 (Unit 1 Instr. Rack Area OC504 El. 166')				
S27 (POC)	1H13-U712 (Unit 1 Instr. Rack Area OC504 El. 166')				
S28 (POC)	1H13-U712 (Unit 1 Instr. Rack Area OC504 El. 166')				
S30 (POC)	1H13-U712 (Unit 1 Instr. Rack Area OC504 El. 166')				

(TS) Represents thermal detectors
 (POC) Represents products of combustion detectors
 * One Channel (Typical of 17 shown on this page)

DEFINITIONS FOR
 "CHANNELS", "TRIP SYSTEMS", AND "TRIP FUNCTIONS"
 FOR FIRE DETECTION INSTRUMENTATION TABLE 3.3.7.9-1 (Continued)

<u>Detector</u>	<u>Parameter</u>	<u>Logic</u>	<u>Function</u>		
S01 (TS)	1H13-U714 (Unit 1 Instr. Rack Area OC504 El. 166')	} Any One	} Produces An Alarm, Disch. Halon		
S02 (TS)	1H13-U714 (Unit 1 Instr. Rack Area OC504 El. 166')				
S03 (TS)	1H13-U714 (Unit 1 Instr. Rack Area OC504 El. 166')				
S04 (TS)	*1H13-U714 (Unit 1 Instr. Rack Area OC504 El. 166')				
S05 (TS)	1H13-U714 (Unit 1 Instr. Rack Area OC504 El. 166')				
S06 (TS)	1H13-U714 (Unit 1 Instr. Rack Area OC504 El. 166')				
S07 (TS)	1H13-U714 (Unit 1 Instr. Rack Area OC504 El. 166')				
S08 (TS)	1H13-U714 (Unit 1 Instr. Rack Area OC504 El. 166')				
S09 (TS)	1H13-U714 (Unit 1 Instr. Rack Area OC504 El. 166')				
S10 (TS)	1H13-U714 (Unit 1 Instr. Rack Area OC504 El. 166')				
S13 (POC)	1H13-U714 (Unit 1 Instr. Rack Area OC504 El. 166')				
S14 (POC)	1H13-U714 (Unit 1 Instr. Rack Area OC504 El. 166')				
S15 (POC)	1H13-U714 (Unit 1 Instr. Rack Area OC504 El. 166')				
S16 (POC)	1H13-U714 (Unit 1 Instr. Rack Area OC504 El. 166')				
S25 (POC)	1H13-U714 (Unit 1 Instr. Rack Area OC504 El. 166')				
S26 (POC)	1H13-U714 (Unit 1 Instr. Rack Area OC504 El. 166')			} Any One	} Produces An Alarm
S27 (POC)	1H13-U714 (Unit 1 Instr. Rack Area OC504 El. 166')				
S28 (POC)	1H13-U714 (Unit 1 Instr. Rack Area OC504 El. 166')				
S29 (POC)	1H13-U714 (Unit 1 Instr. Rack Area OC504 El. 166')				
S30 (POC)	1H13-U714 (Unit 1 Instr. Rack Area OC504 El. 166')				
S31 (POC)	1H13-U714 (Unit 1 Instr. Rack Area OC504 El. 166')				
S32 (POC)	1H13-U714 (Unit 1 Instr. Rack Area OC504 El. 166')				
S33 (POC)	1H13-U714 (Unit 1 Instr. Rack Area OC504 El. 166')				
S34 (POC)	1H13-U714 (Unit 1 Instr. Rack Area OC504 El. 166')				

(TS) Represents thermal detectors
 (POC) Represents products of combustion detectors
 * One Channel (Typical of 23 shown on this page)
 Llsd74

DEFINITIONS FOR
 "CHANNELS", "TRIP SYSTEMS", AND "TRIP FUNCTIONS"
 FOR FIRE DETECTION INSTRUMENTATION TABLE 3.3.7.9-1 (Continued)

<u>Detectors</u>	<u>Parameter</u>	<u>Logic</u>	<u>Function</u>		
S03 (TS)	1H13-U732 (Unit 1 Instr. Rack Area OC504 El. 166')	Any One	Produces An Alarm, Disch Halon		
S04 (TS)	*1H13-U732 (Unit 1 Instr. Rack Area OC504 El. 166')				
S05 (TS)	1H13-U732 (Unit 1 Instr. Rack Area OC504 El. 166')				
S06 (TS)	1H13-U732 (Unit 1 Instr. Rack Area OC504 El. 166')				
S07 (TS)	1H13-U732 (Unit 1 Instr. Rack Area OC504 El. 166')				
S08 (TS)	1H13-U732 (Unit 1 Instr. Rack Area OC504 El. 166')				
S09 (TS)	1H13-U732 (Unit 1 Instr. Rack Area OC504 El. 166')				
S10 (TS)	1H13-U732 (Unit 1 Instr. Rack Area OC504 El. 166')				
S13 (POC)	1H13-U732 (Unit 1 Instr. Rack Area OC504 El. 166')			Any One	Produces An Alarm
S14 (POC)	1H13-U732 (Unit 1 Instr. Rack Area OC504 El. 166')				
S15 (POC)	1H13-U732 (Unit 1 Instr. Rack Area OC504 El. 166')				
S16 (POC)	1H13-U732 (Unit 1 Instr. Rack Area OC504 El. 166')				
S25 (POC)	1H13-U732 (Unit 1 Instr. Rack Area OC504 El. 166')				
S26 (POC)	1H13-U732 (Unit 1 Instr. Rack Area OC504 El. 166')				
S27 (POC)	1H13-U732 (Unit 1 Instr. Rack Area OC504 El. 166')				
S28 (POC)	1H13-U732 (Unit 1 Instr. Rack Area OC504 El. 166')				
S29 (POC)	1H13-U732 (Unit 1 Instr. Rack Area OC504 El. 166')				
S30 (POC)	1H13-U732 (Unit 1 Instr. Rack Area OC504 El. 166')				
S31 (POC)	1H13-U732 (Unit 1 Instr. Rack Area OC504 El. 166')				
S32 (POC)	1H13-U732 (Unit 1 Instr. Rack Area OC504 El. 166')				
S33 (POC)	1H13-U732 (Unit 1 Instr. Rack Area OC504 El. 166')				
S34 (POC)	1H13-U732 (Unit 1 Instr. Rack Area OC504 El. 166')				

(TS) Represents thermal detectors
 (POC) Represents products of combustion detectors
 * One Channel (Typical of 22 shown on this page)
 Llsd75

DEFINITIONS FOR
 "CHANNELS", "TRIP SYSTEMS", AND "TRIP FUNCTIONS"
 FOR FIRE DETECTION INSTRUMENTATION TABLE 3.3.7.9-1 (Continued)

<u>Detector</u>	<u>Parameter</u>	<u>Logic</u>	<u>Function</u>		
S03 (TS)	1H13-U733 (Unit 1 Instr Rack Area OC504 El. 166')	Any One	Produces An Alarm, Disch. Halon		
S04 (TS)	1H13-U733 (Unit 1 Instr Rack Area OC504 El. 166')				
S05 (TS)	*1H13-U733 (Unit 1 Instr Rack Area OC504 El. 166')				
S06 (TS)	1H13-U733 (Unit 1 Instr Rack Area OC504 El. 166')				
S07 (TS)	1H13-U733 (Unit 1 Instr Rack Area OC504 El. 166')				
S08 (TS)	1H13-U733 (Unit 1 Instr Rack Area OC504 El. 166')				
S09 (TS)	1H13-U733 (Unit 1 Instr Rack Area OC504 El. 166')				
S10 (TS)	1H13-U733 (Unit 1 Instr Rack Area OC504 El. 166')				
S13 (POC)	1H13-U733 (Unit 1 Instr Rack Area OC504 El. 166')			Any One	Produces An Alarm
S14 (POC)	1H13-U733 (Unit 1 Instr Rack Area OC504 El. 166')				
S15 (POC)	1H13-U733 (Unit 1 Instr Rack Area OC504 El. 166')				
S16 (POC)	1H13-U733 (Unit 1 Instr Rack Area OC504 El. 166')				
S25 (POC)	1H13-U733 (Unit 1 Instr Rack Area OC504 El. 166')				
S26 (POC)	1H13-U733 (Unit 1 Instr Rack Area OC504 El. 166')				
S27 (POC)	1H13-U733 (Unit 1 Instr Rack Area OC504 El. 166')				
S28 (POC)	1H13-U733 (Unit 1 Instr Rack Area OC504 El. 166')				
S29 (POC)	1H13-U733 (Unit 1 Instr Rack Area OC504 El. 166')				
S30 (POC)	1H13-U733 (Unit 1 Instr Rack Area OC504 El. 166')				
S31 (POC)	1H13-U733 (Unit 1 Instr Rack Area OC504 El. 166')				
S32 (POC)	1H13-U733 (Unit 1 Instr Rack Area OC504 El. 166')				
S34 (POC)	1H13-U733 (Unit 1 Instr Rack Area OC504 El. 166')				

(TS) Represents thermal detectors
 (POC) Represents products of combustion detectors
 * One Channel (Typical of 21 shown on this page)

DEFINITIONS FOR
 "CHANNELS", "TRIP SYSTEMS", AND "TRIP FUNCTIONS"
 FOR FIRE DETECTION INSTRUMENTATION TABLE 3.3.7.9-1 (Continued)

<u>Detector</u>	<u>Parameter</u>	<u>Logic</u>	<u>Function</u>		
S03 (TS)	1H13-U734 (Unit 1 Instr. Rack Area OC504 El. 166')	Any One	Produces An Alarm, Disch. Halon		
S04 (TS)	1H13-U734 (Unit 1 Instr. Rack Area OC504 El. 166')				
S05 (TS)	*1H13-U734 (Unit 1 Instr. Rack Area OC504 El. 166')				
S06 (TS)	1H13-U734 (Unit 1 Instr. Rack Area OC504 El. 166')				
S07 (TS)	1H13-U734 (Unit 1 Instr. Rack Area OC504 El. 166')				
S08 (TS)	1H13-U734 (Unit 1 Instr. Rack Area OC504 El. 166')				
S09 (TS)	1H13-U734 (Unit 1 Instr. Rack Area OC504 El. 166')				
S10 (TS)	1H13-U734 (Unit 1 Instr. Rack Area OC504 El. 166')				
S13 (POC)	1H13-U734 (Unit 1 Instr. Rack Area OC504 El. 166')			Any One	Produces An Alarm
S14 (POC)	1H13-U734 (Unit 1 Instr. Rack Area OC504 El. 166')				
S15 (POC)	1H13-U734 (Unit 1 Instr. Rack Area OC504 El. 166')				
S16 (POC)	1H13-U734 (Unit 1 Instr. Rack Area OC504 El. 166')				
S25 (POC)	1H13-U734 (Unit 1 Instr. Rack Area OC504 El. 166')				
S26 (POC)	1H13-U734 (Unit 1 Instr. Rack Area OC504 El. 166')				
S27 (POC)	1H13-U734 (Unit 1 Instr. Rack Area OC504 El. 166')				
S28 (POC)	1H13-U734 (Unit 1 Instr. Rack Area OC504 El. 166')				
S29 (POC)	1H13-U734 (Unit 1 Instr. Rack Area OC504 El. 166')				
S30 (POC)	1H13-U734 (Unit 1 Instr. Rack Area OC504 El. 166')				
S31 (POC)	1H13-U734 (Unit 1 Instr. Rack Area OC504 El. 166')				
S32 (POC)	1H13-U734 (Unit 1 Instr. Rack Area OC504 El. 166')				
S34 (POC)	1H13-U734 (Unit 1 Instr. Rack Area OC504 El. 166')				

(TS) Represents thermal detectors
 (POC) Represents products of combustion detectors
 * One Channel (Typical of 21 shown on this page)

DEFINITIONS FOR
 "CHANNELS", "TRIP SYSTEMS", AND "TRIP FUNCTIONS"
 FOR FIRE DETECTION INSTRUMENTATION TABLE 3.3.7.9-1 (Continued)

<u>Detector</u>	<u>Parameter</u>	<u>Logic</u>	<u>Function</u>		
S03 (TS)	1H13-U735 (Unit 1 Instr. Rack Area OC504 El. 166')	Any One	Produces An Alarm, Disch. Halon		
S04 (TS)	1H13-U735 (Unit 1 Instr. Rack Area OC504 El. 166')				
S05 (TS)	*1H13-U735 (Unit 1 Instr. Rack Area OC504 El. 166')				
S06 (TS)	1H13-U735 (Unit 1 Instr. Rack Area OC504 El. 166')				
S07 (TS)	1H13-U735 (Unit 1 Instr. Rack Area OC504 El. 166')				
S08 (TS)	1H13-U735 (Unit 1 Instr. Rack Area OC504 El. 166')				
S09 (TS)	1H13-U735 (Unit 1 Instr. Rack Area OC504 El. 166')				
S10 (TS)	1H13-U735 (Unit 1 Instr. Rack Area OC504 El. 166')				
S13 (POC)	1H13-U735 (Unit 1 Instr. Rack Area OC504 El. 166')			Any One	Produces An Alarm
S14 (POC)	1H13-U735 (Unit 1 Instr. Rack Area OC504 El. 166')				
S15 (POC)	1H13-U735 (Unit 1 Instr. Rack Area OC504 El. 166')				
S16 (POC)	1H13-U735 (Unit 1 Instr. Rack Area OC504 El. 166')				
S25 (POC)	1H13-U735 (Unit 1 Instr. Rack Area OC504 El. 166')				
S26 (POC)	1H13-U735 (Unit 1 Instr. Rack Area OC504 El. 166')				
S27 (POC)	1H13-U735 (Unit 1 Instr. Rack Area OC504 El. 166')				
S28 (POC)	1H13-U735 (Unit 1 Instr. Rack Area OC504 El. 166')				
S29 (POC)	1H13-U735 (Unit 1 Instr. Rack Area OC504 El. 166')				
S30 (POC)	1H13-U735 (Unit 1 Instr. Rack Area OC504 El. 166')				
S32 (POC)	1H13-U735 (Unit 1 Instr. Rack Area OC504 El. 166')				

(TS) Represents thermal detectors
 (POC) Represents products of combustion detectors
 * One Channel (Typical of 19 shown on this page)

DEFINITIONS FOR
 "CHANNELS", "TRIP SYSTEMS", AND "TRIP FUNCTIONS"
 FOR FIRE DETECTION INSTRUMENTATION TABLE 3.3.7.9-1 (Continued)

<u>Detector</u>	<u>Parameter</u>	<u>Logic</u>	<u>Function</u>
S01 (TS)	1H13-U713 (Unit 1 Instr. Rack Area OC703 El. 189')	} Any One	} Produces An Alarm, Discharges Halon
S02 (TS)	1H13-U713 (Unit 1 Instr. Rack Area OC703 El. 189')		
S03 (TS)	*1H13-U713 (Unit 1 Instr. Rack Area OC703 El. 189')		
S04 (TS)	1H13-U713 (Unit 1 Instr. Rack Area OC703 El. 189')		
S05 (TS)	1H13-U713 (Unit 1 Instr. Rack Area OC703 El. 189')		
S06 (TS)	1H13-U713 (Unit 1 Instr. Rack Area OC703 El. 189')		
S07 (TS)	1H13-U713 (Unit 1 Instr. Rack Area OC703 El. 189')		
S08 (TS)	1H13-U713 (Unit 1 Instr. Rack Area OC703 El. 189')		
S09 (TS)	1H13-U713 (Unit 1 Instr. Rack Area OC703 El. 189')		
S13 (POC)	1H13-U713 (Unit 1 Instr. Rack Area OC703 El. 189')		
S14 (POC)	1H13-U713 (Unit 1 Instr. Rack Area OC703 El. 189')		
S15 (POC)	1H13-U713 (Unit 1 Instr. Rack Area OC703 El. 189')		
S16 (POC)	1H13-U713 (Unit 1 Instr. Rack Area OC703 El. 189')		
S17 (POC)	1H13-U713 (Unit 1 Instr. Rack Area OC703 El. 189')		
S25 (POC)	1H13-U713 (Unit 1 Instr. Rack Area OC703 El. 189')		
S26 (POC)	1H13-U713 (Unit 1 Instr. Rack Area OC703 El. 189')		
S27 (POC)	1H13-U713 (Unit 1 Instr. Rack Area OC703 El. 189')		
S28 (POC)	1H13-U713 (Unit 1 Instr. Rack Area OC703 El. 189')		
S29 (POC)	1H13-U713 (Unit 1 Instr. Rack Area OC703 El. 189')		
S30 (POC)	1H13-U713 (Unit 1 Instr. Rack Area OC703 El. 189')		
S31 (POC)	1H13-U713 (Unit 1 Instr. Rack Area OC703 El. 189')		
S32 (POC)	1H13-U713 (Unit 1 Instr. Rack Area OC703 El. 189')		
S33 (POC)	1H13-U713 (Unit 1 Instr. Rack Area OC703 El. 189')		
S34 (POC)	1H13-U713 (Unit 1 Instr. Rack Area OC703 El. 189')		

(TS) Represents thermal detectors
 (POC) Represents products of combustion detectors
 * One Channel (Typical of 24 shown on this page)

DEFINITIONS FOR
 "CHANNELS", "TRIP SYSTEMS", AND "TRIP FUNCTIONS"
 FOR FIRE DETECTION INSTRUMENTATION TABLE 3.3.7.9-1 (Continued)

<u>Detector</u>	<u>Parameter</u>	<u>Logic</u>	<u>Function</u>		
S03 (TS)	1H13-U715 (Unit 1 Instr. Rack Area OC703 El. 189')	Any One	Produces An Alarm, Disch. Halon		
S04 (TS)	*1H13-U715 (Unit 1 Instr. Rack Area OC703 El. 189')				
S05 (TS)	1H13-U715 (Unit 1 Instr. Rack Area OC703 El. 189')				
S06 (TS)	1H13-U715 (Unit 1 Instr. Rack Area OC703 El. 189')				
S07 (TS)	1H13-U715 (Unit 1 Instr. Rack Area OC703 El. 189')				
S08 (TS)	1H13-U715 (Unit 1 Instr. Rack Area OC703 El. 189')				
S09 (TS)	1H13-U715 (Unit 1 Instr. Rack Area OC703 El. 189')				
S10 (TS)	1H13-U715 (Unit 1 Instr. Rack Area OC703 El. 189')				
S13 (POC)	1H13-U715 (Unit 1 Instr. Rack Area OC703 El. 189')			Any One	Produces An Alarm
S14 (POC)	1H13-U715 (Unit 1 Instr. Rack Area OC703 El. 189')				
S15 (POC)	1H13-U715 (Unit 1 Instr. Rack Area OC703 El. 189')				
S16 (POC)	1H13-U715 (Unit 1 Instr. Rack Area OC703 El. 189')				
S25 (POC)	1H13-U715 (Unit 1 Instr. Rack Area OC703 El. 189')				
S26 (POC)	1H13-U715 (Unit 1 Instr. Rack Area OC703 El. 189')				
S27 (POC)	1H13-U715 (Unit 1 Instr. Rack Area OC703 El. 189')				
S28 (POC)	1H13-U715 (Unit 1 Instr. Rack Area OC703 El. 189')				
S29 (POC)	1H13-U715 (Unit 1 Instr. Rack Area OC703 El. 189')				
S30 (POC)	1H13-U715 (Unit 1 Instr. Rack Area OC703 El. 189')				

(TS) Represents thermal detectors
 (POC) Represents products of combustion detectors
 * One Channel (Typical of 18 shown on this page)

DEFINITIONS FOR
"CHANNELS", "TRIP SYSTEMS", AND "TRIP FUNCTIONS"
FOR FIRE DETECTION INSTRUMENTATION TABLE 3.3.7.9-1 (Continued)

<u>Detector</u>	<u>Parameter</u>	<u>Logic</u>	<u>Function</u>		
S01 (TS)	1H13-U717 (Unit 1 Instr. Rack Area OC703 El. 189')	Any One	Produces An Alarm, Disch. Halon		
S02 (TS)	1H13-U717 (Unit 1 Instr. Rack Area OC703 El. 189')				
S03 (TS)	*1H13-U717 (Unit 1 Instr. Rack Area OC703 El. 189')				
S04 (TS)	1H13-U717 (Unit 1 Instr. Rack Area OC703 El. 189')				
S05 (TS)	1H13-U717 (Unit 1 Instr. Rack Area OC703 El. 189')				
S06 (TS)	1H13-U717 (Unit 1 Instr. Rack Area OC703 El. 189')				
S07 (TS)	1H13-U717 (Unit 1 Instr. Rack Area OC703 El. 189')				
S08 (TS)	1H13-U717 (Unit 1 Instr. Rack Area OC703 El. 189')				
S13 (POC)	1H13-U717 (Unit 1 Instr. Rack Area OC703 El. 189')				
S14 (POC)	1H13-U717 (Unit 1 Instr. Rack Area OC703 El. 189')				
S15 (POC)	1H13-U717 (Unit 1 Instr. Rack Area OC703 El. 189')				
S16 (POC)	1H13-U717 (Unit 1 Instr. Rack Area OC703 El. 189')				
S17 (POC)	1H13-U717 (Unit 1 Instr. Rack Area OC703 El. 189')				
S25 (POC)	1H13-U717 (Unit 1 Instr. Rack Area OC703 El. 189')				
S26 (POC)	1H13-U717 (Unit 1 Instr. Rack Area OC703 El. 189')			Any One	Produces An Alarm
S27 (POC)	1H13-U717 (Unit 1 Instr. Rack Area OC703 El. 189')				
S28 (POC)	1H13-U717 (Unit 1 Instr. Rack Area OC703 El. 189')				
S29 (POC)	1H13-U717 (Unit 1 Instr. Rack Area OC703 El. 189')				
S30 (POC)	1H13-U717 (Unit 1 Instr. Rack Area OC703 El. 189')				
S31 (POC)	1H13-U717 (Unit 1 Instr. Rack Area OC703 El. 189')				
S32 (POC)	1H13-U717 (Unit 1 Instr. Rack Area OC703 El. 189')				
S33 (POC)	1H13-U717 (Unit 1 Instr. Rack Area OC703 El. 189')				
S34 (POC)	1H13-U717 (Unit 1 Instr. Rack Area OC703 El. 189')				

(TS) Represents thermal detectors
(POC) Represents products of combustion detectors
* One Channel (Typical of 23 shown on this page)

DEFINITIONS FOR
 "CHANNELS", "TRIP SYSTEMS", AND "TRIP FUNCTIONS"
 FOR FIRE DETECTION INSTRUMENTATION TABLE 3.3.7.9-1 (Continued)

<u>Detector</u>	<u>Parameter</u>	<u>Logic</u>	<u>Function</u>		
S01 (TS)	1H13-U736 (Unit 1 Instr. Rack Area OC703 El. 189')	Any One	Produces An Alarm, Disch. Halon		
S02 (TS)	1H13-U736 (Unit 1 Instr. Rack Area OC703 El. 189')				
S03 (TS)	*1H13-U736 (Unit 1 Instr. Rack Area OC703 El. 189')				
S04 (TS)	1H13-U736 (Unit 1 Instr. Rack Area OC703 El. 189')				
S05 (TS)	1H13-U736 (Unit 1 Instr. Rack Area OC703 El. 189')				
S06 (TS)	1H13-U736 (Unit 1 Instr. Rack Area OC703 El. 189')				
S07 (TS)	1H13-U736 (Unit 1 Instr. Rack Area OC703 El. 189')				
S08 (TS)	1H13-U736 (Unit 1 Instr. Rack Area OC703 El. 189')				
S13 (POC)	1H13-U736 (Unit 1 Instr. Rack Area OC703 El. 189')				
S14 (POC)	1H13-U736 (Unit 1 Instr. Rack Area OC703 El. 189')				
S15 (POC)	1H13-U736 (Unit 1 Instr. Rack Area OC703 El. 189')				
S16 (POC)	1H13-U736 (Unit 1 Instr. Rack Area OC703 El. 189')				
S17 (POC)	1H13-U736 (Unit 1 Instr. Rack Area OC703 El. 189')				
S25 (POC)	1H13-U736 (Unit 1 Instr. Rack Area OC703 El. 189')			Any One	Produces An Alarm
S26 (POC)	1H13-U736 (Unit 1 Instr. Rack Area OC703 El. 189')				
S27 (POC)	1H13-U736 (Unit 1 Instr. Rack Area OC703 El. 189')				
S28 (POC)	1H13-U736 (Unit 1 Instr. Rack Area OC703 El. 189')				
S29 (POC)	1H13-U736 (Unit 1 Instr. Rack Area OC703 El. 189')				
S30 (POC)	1H13-U736 (Unit 1 Instr. Rack Area OC703 El. 189')				
S31 (POC)	1H13-U736 (Unit 1 Instr. Rack Area OC703 El. 189')				
S32 (POC)	1H13-U736 (Unit 1 Instr. Rack Area OC703 El. 189')				
S33 (POC)	1H13-U736 (Unit 1 Instr. Rack Area OC703 El. 189')				
S34 (POC)	1H13-U736 (Unit 1 Instr. Rack Area OC703 El. 189')				

(TS) Represents thermal detectors

(POC) Represents products of combustion detectors

* One Channel (Typical of 22 shown on this page)

DEFINITIONS FOR
 "CHANNELS", "TRIP SYSTEMS", AND "TRIP FUNCTIONS"
 FOR FIRE DETECTION INSTRUMENTATION TABLE 3.3.7.9-1 (Continued)

<u>Detector</u>	<u>Parameter</u>	<u>Logic</u>	<u>Function</u>		
S03 (TS)	1H13-U737 (Unit 1 Instr. Rack Area OC703 El. 189')	Any One	Produces An Alarm, Disch. Halon		
S04 (TS)	1H13-U737 (Unit 1 Instr. Rack Area OC703 El. 189')				
S05 (TS)	*1H13-U737 (Unit 1 Instr. Rack Area OC703 El. 189')				
S06 (TS)	1H13-U737 (Unit 1 Instr. Rack Area OC703 El. 189')				
S07 (TS)	1H13-U737 (Unit 1 Instr. Rack Area OC703 El. 189')				
S08 (TS)	1H13-U737 (Unit 1 Instr. Rack Area OC703 El. 189')				
S09 (TS)	1H13-U737 (Unit 1 Instr. Rack Area OC703 El. 189')				
S10 (TS)	1H13-U737 (Unit 1 Instr. Rack Area OC703 El. 189')				
S13 (POC)	1H13-U737 (Unit 1 Instr. Rack Area OC703 El. 189')			Any One	Produces An Alarm
S14 (POC)	1H13-U737 (Unit 1 Instr. Rack Area OC703 El. 189')				
S15 (POC)	1H13-U737 (Unit 1 Instr. Rack Area OC703 El. 189')				
S16 (POC)	1H13-U737 (Unit 1 Instr. Rack Area OC703 El. 189')				
S25 (POC)	1H13-U737 (Unit 1 Instr. Rack Area OC703 El. 189')				
S26 (POC)	1H13-U737 (Unit 1 Instr. Rack Area OC703 El. 189')				
S27 (POC)	1H13-U737 (Unit 1 Instr. Rack Area OC703 El. 189')				
S28 (POC)	1H13-U737 (Unit 1 Instr. Rack Area OC703 El. 189')				
S29 (POC)	1H13-U737 (Unit 1 Instr. Rack Area OC703 El. 189')				
S30 (POC)	1H13-U737 (Unit 1 Instr. Rack Area OC703 El. 189')				

(TS) Represents thermal detectors
 (POC) Represents products of combustion detectors
 * One Channel (Typical of 18 shown on this page)

DEFINITIONS FOR
 "CHANNELS", "TRIP SYSTEMS", AND "TRIP FUNCTIONS"
 FOR LOOSE PART DETECTION SYSTEM 3.3.7.10

<u>Trip Unit/ Detector</u>	<u>Parameter/Sensor</u>	<u>Logic/Function</u>
C87-YIT-R810	RPV Bottom 270°	Any Two or More Provide Loose Part Recording & Alarm
C87-YIT-R811	*RPV Bottom 90°	
C87-YIT-R812	Reactor Recirc Pump A Suction	
C87-YIT-R813	Reactor Recirc Pump B Suction	
C87-YIT-R814	Main Steam Line A	
C87-YIT-R815	Main Steam Line B	
C87-YIT-R816	HPCS Injection Header	
C87-YIT-R817	LPCS Injection Header	

* One Channel (Typical of 8 shown on this page)

NOTE: There are 8 passive sensors, as listed below, that are provided for backup capability and to increase monitoring flexibility. These passive sensors can be actuated by interchanging their respective signal cable with one of the active sensors' cable at the local monitoring panel.

- RPV Bottom 270°
- RPV Bottom 90°
- Feed Water Line A
- Feed Water Line B
- Main Steam Line C
- Main Steam Line D
- Reactor Recirc Pump A Discharge
- Reactor Recirc Pump B Discharge

DEFINITIONS FOR
 "CHANNELS", "TRIP SYSTEMS", AND "TRIP FUNCTIONS"
 FOR RADIOACTIVE LIQUID EFFLUENT MONITORING
 INSTRUMENTATION TABLE 3.3.7.11-1

<u>Trip Unit</u>	<u>Parameter</u>	<u>Function</u>
SG17-FS-K238	*Flow Rate Measurement for Liquid Radwaste Effluent - Hi	Alarm/Monitor
SD17-RITS-K606	Gross Radioactivity Monitor for Liquid Radwaste Effluent Hi-Hi	Any — Close Liquid Radwaste One — Outlet Valve to Cooling Tower Blowdown
IN71-FSL-K600	Flow Rate Measurement for Discharge Canal - Lo	Alarm/Monitor

* One Channel (Typical of 3 shown on this page)

DEFINITIONS FOR
 "CHANNELS", "TRIP SYSTEMS", AND "TRIP FUNCTIONS"
 FOR RADIOACTIVE GASEOUS EFFLUENT MONITORING
 INSTRUMENTATION TABLE 3.3.7.12-1

<u>Trip Unit/ Monitor/ Transmitter</u>	<u>Parameter</u>	<u>Function</u>
<u>Radwaste Bldg Vent Mon System</u>		
D17-RITS-K602	Noble Gas Activity Monitor-Providing Alarm	Monitoring/Alarm
D17-P001	Iodine Sampler	Grab Sample
D17-P001	Particulate Sampler	Grab Sample
D17-FI-R201A	Eff. Sys Flow Rate Measuring Device	Indication
D17-FI-R062A	Sampler Flow Rate Measuring Device	Indication
<u>Main Condenser Offgas Treatment System Explosive Gas Monitoring System</u>		
N64-AR-R605	Hydrogen Monitor A	Monitoring
N64-AR-R605	Hydrogen Monitor B	Monitoring
<u>Containment Vent Monitoring System</u>		
D17-RITS-K603	*Noble Gas Activity Monitor Providing Alarm	Monitoring/Alarm
D17-P002	Iodine Sampler	Grab Sample
D17-P002	Particulate Sampler	Grab Sample
D17-FI-R201B	Eff. Sys Flow Rate Measuring Device	Indication
D17-FI-R062B	Sampler Flow Rate Measuring Device	Indication
<u>Turbine Bldg Vent Mon System</u>		
D17-RITS-K620	Noble Gas Activity Monitor	Monitor
D17-P004	Iodine Sampler	Grab Sample
D17-P004	Particulate Sampler	Grab Sample
D17-FI-R201D	Eff Sys Flow Rate Monitor	Indication
D17-FI-R062D	Sampler Flow Rate Monitor	Indication
<u>Offgas Pre-Treatment Monitor</u>		
D17-RITS-K612	Noble Gas Activity Monitor	Monitor
<u>Offgas Post-Treatment Monitor</u>		
D17-RITS-K601A	Noble Gas Activity Monitor(1)	Monitor/Alarm
D17-RITS-K601B	Noble Gas Activity Monitor(1)	Monitor/Alarm

* One Channel (Typical of 20 shown on this page)
 (1) Logics, Trip Systems, and Trip Functions for automatic termination of release are shown on Radiation Monitoring Instrumentation Table 3.3.7.1-1.

DEFINITIONS FOR
 "CHANNELS", "TRIP SYSTEMS", AND "TRIP FUNCTIONS"
 FOR RADIOACTIVE GASEOUS EFFLUENT MONITORING
 INSTRUMENTATION TABLE 3.3.7.12-1 (CONTINUED)

<u>Trip Unit/ Monitor/ Transmitter</u>	<u>Parameter</u>	<u>Function</u>
<u>Fuel Handling</u>		
<u>Area Vent Monitor</u>		
D17-RITS-K619	*Noble Gas Activity Mon.	Monitor
D17-P003	Iodine Sampler	Grab Sample
D17-P003	Particulate Sampler	Grab Sample
D17-FI-R201C	Eff Sys Flow Rate Monitor	Indication
D17-FI-R062C	Sampler Flow Rate Monitor	Indication

* One Channel (Typical of 5 shown on this page)

DEFINITIONS FOR
 "CHANNELS", "TRIP SYSTEMS", AND "TRIP FUNCTIONS"
 FOR PLANT SYSTEMS ACTUATION INSTRUMENTATION TABLE 3.3.8-1

Trip Unit	Parameter	Logic	
B21-LIS-N691A	RPV Level Low-Level 1	} — Either — Both —	Initiates LPCS, LPCI and Starts Timer K93A
B21-LIS-N691E	RPV Level Low-Level 1		
B21-PIS-N694A	*Drywell Pressure-High		
B21-PIS-N694E	Drywell Pressure-High	} — Either — Three —	Opens Vlv. E12-F028A Closes Vlv. E12-F042A. TRIP FUNCTION
E12-PIS-N662A	Containment Pressure-High		
E12-PIS-N662C	Containment Pressure-High		
E12-K93A	Timer System A (10 MIN)	Three	
TRIP SYSTEM			
B21-LIS-N691B	RPV Level Low-Level 1	} — Either — Both —	Initiates LPCI B & C and Starts Timer K93B
B21-LIS-N691F	RPV Level Low-Level 1		
B21-PIS-N694B	Drywell Pressure - High		
B21-PIS-N694F	Drywell Pressure - High	} — Either — Three —	Closes E12-F042B, Opens E12-F028B TRIP FUNCTION
E12-PIS-N662D	Containment Pressure-High		
E12-PIS-N662E	Containment Pressure-High		
E12-K93B and E12-K116	Timer System B (11.5 MIN)	Out Of Three	
TRIP SYSTEM			
<u>Feedwater System/Main Turbine Trip System</u>			
C34-LSH-K624A	RPV Level High - Level 8	} — Two out of Three —	Trip Rx Feed Pumps and Main Turbine TRIP FUNCTION
C34-LSH-K624B	RPV Level High - Level 8		
C34-LSH-K624C	RPV Level High - Level 8		
TRIP SYSTEM			

* One Channel (Typical of 17 shown on this page)

NOTE: High Drywell Pressure & RPV Level Low One Out of Two Twice Logic Starts RHR Pump and Opens F042 Valves. Then the Containment Pressure High and the Timer for the System Closes F042A and B and Opens F028A and B. This logic drawing does not show RHR A & B Pump start timers, containment spray timer or manual initiation for RHR in LPCI mode or manual initiation for containment spray.

DEFINITIONS FOR
 "CHANNELS", "TRIP SYSTEMS", AND "TRIP FUNCTIONS"
 FOR PLANT SYSTEMS ACTUATION INSTRUMENTATION TABLE 3.3.8.1 (Continued)

Trip Unit	Parameter	Logic/Function
Suppression Pool Makeup System		
B21-LIS-N691B	RPV Level Low-Level 1	} Either } } Both } } Either }
B21-PIS-N694B	Drywell Pressure-High	
B21-LIS-N691F	RPV Level Low-Level 1	
B21-PIS-N694F	*Drywell Pressure-High	} Both } } Either }
E12-HS-M617	RHR B/C Manual Initiation	
E30-HS-M600B	SPMU Manual Initiation	} Both } } Any } } One }
E30-HS-M600D	SPMU Manual Initiation	
E30-LIS-N600B	Suppression Pool Level-Low	} Any } } One }
E30-LIS-N600D	Suppression Pool Level-Low	
C71-PIS-N650B	Drywell Pressure-High	} Either } } Both } } Either }
B21-LS-N682B	RPV Level Low-Level 2	
B21-HS-N630B	Manual Initiation	} Both } } Starts } } 30 Minute } } Timer }
C71-PIS-650C	Drywell Pressure-High	
B21-LS-N682C	RPV Level Low-Level 2	
B21-HS-N630C	Manual Initiation	TRIP SYSTEM
TRIP SYSTEM		
B21-LIS-N691A	RPV Level Low-Level 1	} Either } } Both } } Either }
B21-PIS-N694A	Drywell Pressure-High	
B21-LIS-N691E	RPV Level Low-Level 1	
B21-PIS-N694E	Drywell Pressure-High	} Both } } Any } } One }
E21-HS-M613	LPCS Manual Initiation	
E30-HS-M600A	SPMU Manual Initiation	} Both } } Any } } One }
E30-HS-M600C	SPMU Manual Initiation	
E30-LIS-N600A	Suppression Pool Level-Low	} Any } } One }
E30-LIS-N600C	Suppression Pool Level-Low	
C71-PIS-N650A	Drywell Pressure-High	} Either } } Both } } Either }
B21-LS-N682A	RPV Level Low-Level 2	
B21-HS-N630A	Manual Initiation	} Both } } Starts } } 30 Minute } } Timer }
C71-PIS-650D	Drywell Pressure-High	
B21-LS-N682D	RPV Level Low-Level 2	
B21-HS-N630D	Manual Initiation	TRIP SYSTEM
TRIP SYSTEM		

* One Channel (Typical of 30 shown on this page)