



Pinanski Building  
One University Avenue  
Lowell, Massachusetts 01854  
tel: 978.934.3366  
fax: 978.934.4067  
url: www.uml.edu/radlab

**RADIATION LABORATORY**

October 18, 2019

U.S. Nuclear Regulatory Commission  
ATTN: Document Control Desk  
Washington, DC 20555-0001

REFERENCE: University of Massachusetts-Lowell Research Reactor  
Docket No. 50-223; License No. R-125

SUBJECT: Response to NRC letter dated July 19, 2019 – Request for Additional Information Regarding the Renewal of Facility Operating License No. R-125 for the University of Massachusetts-Lowell Research Reactor and Primarily Related to Instrumentation and Controls (EPID No. L-2015-RNW-0001) and Request for 60 day extension to respond to specified RAI related to same.

Please find the enclosed response document for the above referenced request for additional information concerning the renewal of license No. R-125. The document includes supporting documents in appendices in support of specific RAIs.

In addition, a 60-day extension is hereby requested to complete the responses to RAI 7.4c, 7.4a, and 7.5d. These responses require the submittal of vendor affidavits under 10CFR 2.390 for public withholding of proprietary documentation.

Please direct any requests for additional information regarding this submittal to Mr. Leo Bobek, Reactor Supervisor at the above address.

I declare under penalty of perjury that the foregoing is true and correct.

Sincerely,

A handwritten signature in black ink, appearing to read 'Leo M. Bobek'.

Leo M. Bobek  
Reactor Supervisor, Radiation Laboratory

Enclosure:  
Response to NRC RAI letter dated 07/19/19

**RAI-7.1**

The regulations in 10 CFR 50.34(b)(2) require that the SAR contain a description and analysis of the structures, systems, and components (SSCs) of the facility, with emphasis upon performance requirements; the bases, with technical justification therefore, upon which such requirements have been established; and the evaluations required to show that safety functions will be accomplished. The description shall be sufficient to permit understanding of the system designs and their relationship to safety evaluations. Additionally, the regulations in 10 CFR 50.34(b)(6)(iv) state, in part, that final safety analysis report shall include plans for conduct of normal operations, including maintenance, surveillance, and periodic testing of SSCs.

The guidance in NUREG-1537, Part 1, Section 7.1, states, in part, the applicant should describe the instrumentation and control (I&C) systems, including block, logic, and process flow diagrams showing major components and subsystems, and connections among them. Additionally, the applicant should summarize the technical aspects, safety, philosophy, and objectives of the I&C system design recommended by Section 7.2 and should discuss such factors as redundancy, diversity, and isolation of functions.

Provide the following, or justify why no additional information is required:

- a. Details are provided on the I&C systems in the UMLRR SAR, predominantly in Chapter 7. However, it is not clear which I&C systems and descriptions existed at the time Facility Operating License No. R-125 Facility License was last renewed (or those I&C systems that were the subject of a license amendment related to I&C systems since the last renewal); which I&C systems were implemented without prior NRC approval since the last renewal; and which I&C systems are proposed as part of the current license renewal application.

Provide a detailed description of the changes proposed in license renewal for the I&C systems that includes the recommended details of Sections 3.1, 7.1, and 7.2 of NUREG-1537, Part 1. The description should reference the specific SAR sections (or SAR supplements provided in support of license renewal) that discuss the systems that are the subject of the proposed changes. The description should:

- describe the design of the proposed Thermo Scientific Wide Range Log Period Power Module (PPM) and the General Atomics (GA) NMP-1000 Modules and discuss how they meet the UMLRR design criteria of the flux monitoring systems, such as:
  - design for the complete range of normal, transient, and accident conditions,
  - quality standards commensurate with the safety function they provide; and,
  - the reactor protection system (RPS) design criteria identified in Section 7.2.1 of the UMLRR SAR.
- include a detailed discussion of any differences (e.g., scram detector voltage, etc.) between the proposed systems and any existing systems that are being removed or replaced,
- discuss any proposed TSs, including surveillance TSs and intervals, and the detailed design bases for the TS specific to design and operation that are necessary to ensure the availability and operability of the proposed I&C systems (e.g., Thermo Scientific Wide Range Log PPM and GA NMP-1000s).

### **Response to RAI 7.1a**

The original power monitoring channels as described in the UMLRR 1985 FSAR for the previous relicensing were manufactured by General Electric in the late 1960's. The two wide-range linear channels and one logarithmic power/period channel were replaced in 1997 with instruments manufactured by General Atomics (GA). A 10CFR 50.59 evaluation was performed for the 1997 change and has been included in the response to RAI 7.3. As part of this relicensing effort, new GA power monitoring channels (two wide-range linear channels and one logarithmic power/period channel) as described in the 2015 draft SAR were to be installed. As discussed in various communications with the NRC and as part of the NRC site visit and I&C audit on 7/24/17, a facility staff decision was made not to use the GA logarithmic power/period channel for technical reasons. Instead, the facility procured a wide range logarithmic power/period instrument (model TR-10) from ThermoFisher-Scientific (TFS). According to the manufacturer the TFS TR-10 PPM (hereafter referred to as the PPM) has been installed and used at several NRC licensed non-power reactors, including: MURR, RINSC, NCSU, Ohio State University, Penn State University, Texas A&M, Oregon State University, Reed College, MU-Rolla, and UC-Irvine. An update to the draft SAR section 7.4.1.2 describing the TFS PPM was submitted to NRC in a letter dated 4/10/19 (ADAMS Accession No. ML19100A273). The new GA linear power channels have been described in the draft SAR chapter 7.

The GA User Manual (Section 1.4) states the NMP1000 was developed and tested in accordance with ANS/ASME NQA-1-2000, Quality Assurance Requirements for Nuclear Facility Applications. The TFS Quality Assurance Program Manual Rev. 22 (Section III) states the TFS Nuclear Systems and Services products meet the objectives of 10CFR 50 Appendix B and ANSI/ASME NQA-1-2000 & 2008-09a. The TFS Quality Assurance Program is applicable to the PPM.

The power measuring channels meet the applicable design criteria for the reactor protection system identified in draft SAR 7.2.1. The applicable criteria are: Single failure, Independence and Redundancy – there are three powering channels, each operating independently and each capable of scrambling the reactor. Two of the channels are identical multi-range linear power monitors from the same manufacturer. The third channel is a wide range linear and logarithmic power and period monitor from another manufacturer. A failure in one or even two of the channels will not affect the remaining channel(s) from performing the intended function of monitoring power level and shutting down the reactor for an overpower condition; Reliability – demonstrated by the application of NQA-1 criteria in the manufacturing process. Testability – each of the channels have design features for functional testing and calibration capability. The design specifications for the original GE channels, the 1997 GA channels, and the new channels are provided in the tables on the next two pages. The design specifications for the new NMP1000 and PPM are deemed to meet the design criteria for the UMLRR reactor protection system.

TS 3.2.5 lists the minimum channels required for reactor operation, including the power measuring instruments. TS 3.2.3 lists the scram set-points for each power channel. TS 4.2.3 lists the surveillance requirements for checks, tests, and calibrations for the power channels. Each of

the channels has design features for the functional testing and calibration required by the TS to assure operability.

Linear Channel Specifications for UMLRR			
SPECIFICATION	GE PICO <sup>1</sup>	NMP-1000 GEN 1	NMP-1000 GEN 2 <sup>2</sup>
<b>Current</b>	1.0E-12 to 1.0E-3 A Covering eight decade ranges in nine teen steps	1.0E-11 to 1.0-3 A or Covering seven decade ranges	1E-11 to 1.0E-3 Amperes
<b>Linearity</b>	±2%at full scale, 1E-12&1E-11 ±3%>1E-11	± 1% of Full Scale on upper 5 ranges; ± 2.5% of Full Scale on lower 2 ranges	± 1% of Full Scale on upper 5 ranges; ± 2.5% of Full Scale on lower 2 ranges
<b>Temperature Coeff.</b>	±0.08% per deg. C 0-55 deg.	± 0.15% / °C maximum in the range of 10° to 55°C	± 0.15% / °C maximum in the range of 10° to 55°C
<b>Response time</b>			
	10 <sup>-6</sup> to 10 <sup>-3</sup> Amperes	1 msec	<1 msec
	10 <sup>-8</sup> to 10 <sup>-5</sup> Amperes	1 msec	<2 msec (E-7), <20 msec (E-8)
	10 <sup>-9</sup> to 10 <sup>-8</sup> Amperes	10 msec	<200 msec (E-9), <2 sec (E-10)
	10 <sup>-11</sup> to 10 <sup>-9</sup> Amperes	100 msec	<2sec (E-10), <20sec(E-11)
<b>Power</b>	1 1.5 VAC +10%, 50I60HZ, 60W	117 VAC ± 10% 50/60 Hz @ 1.0 Amp	117 VAC ± 10% 50/60 Hz @ 1 Amp
<b>CALIBRATION/TEST</b>	none	2 fixed currents for calibration, 1 adjustable for multi-range function test and trip testing. HV trip test.	2 fixed currents for calibration, 1 adjustable for multi-range function test and trip testing. HV trip test.
<b>BISTABLE TRIPS</b>	2 trips, rear panel using one DPDT relay and one electronic contact	High Voltage, High Power and Alarm: User Configurable (increasing or decreasing) Logic Level output and two form "C" contacts per trip	High Voltage, High Power and Alarm: User Configurable (increasing or decreasing) Logic Level output and two form "C" contacts per trip
<b>OUTPUTS</b>	Front Panel	Linear Power (0 to 120%) and range indication (auto & manual switching)	Linear Power (0 to 120%) and range indication (auto & manual switching)
	Remote meter	High Voltage (0 to 1000 VDC)	High Voltage (0 to 1000 VDC)
	Recorder	0 -10 VDC or 0-1mA	0 -10 VDC or 4-20mA
	High Voltage	0 -1 VDC or 0 - 0.1 VDC or 4-20mA	0 - 1 VDC or 0 - 0.1 VDC or 4-20mA
Compensation	0-900 VDC	300 to 800 VDC @ 2.6 watts	0 to 1,000 VDC @ 3.0mA
		0-100 VDC	-30 to 200 VDC

Notes: (1) Original equipment replaced by NMP1000 Gen1 (2) proposed replacement

Log Channel Specifications for UMLRR			
SPECIFICATION	GE LOG N <sup>1</sup>	NLI- IOOO GEN 1	THERMO TR 10-5 <sup>2</sup>
Detector	Compensated Ion Chamber	Compensated Ion Chamber	Fission Chamber W/campbellling
Current	1.0E-10 to 1.0E-4 amps	1.0E-10 to 1.0E-3 amps	1.0E-11 to 1.0E-3 Amperes
Linearity	±2%at full scale	±3%at full scale	± 1% of Full Scale on upper 5 ranges; ± 2.5% of Full Scale on lower 2 ranges
Temperature Coeff.	±0.15% per °C over 10° - 55°	±0.15% per °C over 10° - 55°	± 0.15% / °C maximum in the range of 10° to 55°C
Neutron Flux Range	3 nv to 3E11 nv	3 nv to 3E11 nv	Source Range 0.1 to 1.0E5 cps; 0.95cps/nv
Range	- 30 to 3 sec (period) 100%(power) 1E-5 to	- 30 to 3 sec (period) 1E-5 to 100%(power)	- 30 to 3 sec (source range period) - 30 to 3 sec (wide range period) 1.0E-8 to 200 % (power)
Power	115 VAC +10%, 50/60HZ, 50W	117 VAC ± 10% 50/60 Hz @ 1.0 Amp	117 VAC ± 10% 50/60 Hz @ 1 Amp
CALIBRATION/TEST	none	2 fixed currents for calibration, 1 adjustable for multi-range function test and trip testing. HV trip test.	7 Level Calibration Checks and 3 Rate Calibration Checks for Signal Porcessor
BISTABLE TRIPS	2 trips, rear panel using one DPDT relay and one electronic contact	1 - High Voltage, 1- High Power, 3 User Configurable (increasing or decreasing 1- Period; 1 Logic Level output. All are adjustable two form "C" contacts and one logic level output per trip	TRIP 1: PR LEVEL> 110% TRIP 2: SR LEVEL (LOW)< 3 CPS TRIP 3: PR LEVEL> 115% (Latching) TRIP 4: PR LEVEL> 11% (Latching) TRIP 5: WR PERIOD < 7 SEC (Latching) TRIP 6: WR PERIOD < 15 SEC NON-OP TRIP (HV)
Front Panel	N/A	Log Power (0.01% to 100%) (Period-30 to 3 sec) High Voltage (0 to 1000 VDC)	<ul style="list-style-type: none"> <li>• SOURCE RANGE LOG LEVEL - CPS</li> <li>• SOURCE RANGE PERIOD - SECONDS</li> <li>• WIDE RANGE LOG LEVEL - PERCENT</li> <li>• WIDE RANGE PERIOD - SECONDS</li> <li>• POWER RANGE LINEAR - PERCENT</li> </ul>
OUTPUTS			
Remote meter	0-10 VDC	N/A	<ul style="list-style-type: none"> <li>• SOURCE RANGE LOG LEVEL - CPS</li> <li>• WIDE RANGE PERIOD - SECONDS</li> <li>• SOURCE RANGE PERIOD - SECONDS</li> <li>• POWER RANGE LINEAR - PERCENT</li> </ul>
Recorder	0-10 VDC	0 - 1 VDC or 0 – 0.1 VDC or 4-20mA	4-20mA
High Voltage	0-900 VDC	300 to 800 VDC @ 2.6 watts	0 to 1,000 VDC @ 3.0mA
Compensation	0-100 VDC	0 to 150 VDC	N/A

Notes: (1) Original equipment replaced by NLI1000 Gen1 (2) proposed replacement

b. The UMLRR SAR describes many alarm and trip functions that activate trip relays or contacts in the RPS scram circuit. However, the SAR does not appear to provide a diagram for the scram circuit train showing the arrangement and configuration of the circuit. Provide a diagram depicting the overall trip circuit showing how each circuit is arranged to ensure a protective system action interrupting the scram circuit.

## **Response to RAI 7.1b**

A scram circuit diagram has been provided in appendix A of this response.

## **RAI-7.2**

The regulations in 10 CFR 50.59, "Changes, test and experiments," state, in part, that a licensee may make changes to the facility and procedures as described in the SAR if the licensee makes a determination (documented in a written evaluation) that no TS change is required, and that the changes do not meet any of the criteria in 10 CFR 50.59(c)(2). Section 50.34(a)(7) of 10 CFR requires an applicant to describe the quality assurance (QA) program for design, fabrication, construction, and testing of the SSCs of the facility, and 10 CFR 50.34(b)(6)(ii) requires that a final safety analysis report include the managerial and administrative controls to be used to assure safe operation. Section 50.34(b)(2) of 10 CFR requires a description and analysis of the SSCs of the facility, with emphasis upon performance requirements, the bases, with technical justification therefor, upon which such requirements have been established, and the evaluations required to show that safety functions will be accomplished. The description shall be sufficient to permit understanding of the system designs and their relationship to safety evaluations.

Section 7.6.1.1 of the UMLRR SAR states that the human machine interface (HMI) display screens use control and input/output hardware manufactured for industrial process control, process monitoring, and data acquisition. The software used to operate the system is stated to be an integrated suite of industrial control and automation software provided by the hardware manufacturer. Section 7.6.1.1 of the SAR also states that the ARMS [area radiation monitoring system] was installed in 1999, the PCS [process controls and instrumentation system] in 2001, and the DCS [display control system] in 2003 under 10 CFR 50.59. SAR Section 7.6.1.3 states that each HMI computer (i.e., PCS, DCS, and ARMS) displays the information from the associated controller and provides a touch screen and a keyboard terminal for manual control of process functions. The SAR further states that, "[t]he display configurations were developed using the integrated software package associated with the hardware consistent with the regulations in 10 CFR 50.34, provide the following information for the HMI displays and integrated software, which does not appear to be included in the SAR, as supplemented, or discuss why no additional information is required:

## **Response to RAI 7.2**

As described in the draft SAR section 7.6.1.1, human machine interface (HMI) displays were installed in association with the area radiation monitoring system in 1999, the process controls in 2001, and the control blade/rod drives in 2003. The HMI are identical to that installed and in use at the recently relicensed Rhode Island Nuclear Science Center (RINSC) 2MW research reactor.

While there is no specific guidance for determining which structures, systems and components (SSC) are safety-related for research reactors, NRC Reg Guide 2.5 endorses ANSI/ANS 15.8 *Quality Assurance Program Requirement for Research Reactors* which includes a definition for "safety-related items" as: "Those physical structures, systems, and components whose intended functions are to prevent accidents that could cause undue risk to the health and safety of workers and the public, or to the research reactor's programs; and to control or mitigate the consequences of such accidents". The UMLRR items that could be considered as safety-related are specified in the proposed license technical specifications (TS). These include the listed channels required for

reactor operation (TS 3.2.5), the listed reactor control system interlocks (TS 3.2.6), and the limits on reactivity addition associated with the reactor control rod/blades (TS 3.2.2). These items have intended functions or design features to prevent the credible accidents analyzed in the draft SAR Chapter 13. The accident analyses demonstrate that limiting safety system settings and limiting conditions for operation for these items have been selected to ensure that no credible accident can lead to unacceptable radiological consequences to people or the environment. Most importantly, the analyses for the credible accidents show no possibility of fuel damage and subsequently no radiological consequences.

The safety evaluations (50.59 reviews) for the ARM, PCS, and DCS HMI are appended to this response document. Given the specified items that may be considered as safety-related are independent of the HMI (SAR section 7.3.2 and 7.4) and none of the items rely on the HMI for the intended functions (LSSS scrams) or design features (interlocks, reactivity worth, and reactivity addition rate) the HMI may be considered as non-safety-related. This is consistent with the risk-informed approach recently emphasized by the Commission (ADAMS Accession No. ML19183A434).

- a. Describe the development of the display configurations, including the name of the integrated software package and verification that a structured process was used in developing the software for both safety and non-safety-related systems.

### **Response to RAI 7.2a**

The software development package used in the HMI systems was manufactured by OPTO-22, Inc. OPTO-22 has been manufacturing equipment and software for industrial automation applications since 1974. The software is Microsoft Windows-based and consists of two main development programs. One program provides for the development of graphical, flowchart-based programming for interaction with input/output (I/O) hardware. The other program provides for the development of a graphical operator interface. Both programs were used by the contractors hired to develop the UMLRR HMI applications (see also Response to RAI 7.2d).

With regards to the OPTO22 software development process, a representative of OPTO22 has stated the company does not have a quality management program (QMP) in accordance with standards such as ISO 9001, but it does employ its own QMP and maintains a software quality assurance plan.

- b. Explain how functional characteristics of the software requirements specifications were properly (and precisely) described for each requirement.

### **Response to RAI 7.2b**

UMLRR staff worked closely with each contractor (Response to RAI 7.2d) during each phase of the HMI development. This included site visits by the contractor, follow-up communications as needed and by providing descriptions of the existing systems for the 1985 FSAR, augmented with additional detail provided by operations staff. The existing hardware interface and 1985 FSAR descriptions were used to communicate the desired functional requirements to the contractor for designing the hardware and software interface. Similar activities occurred during

the actual design of the hardware and software configuration by the contractor. The design process was iterative, again with UMLRR staff working closely with each contractor, to assure each application would perform as expected to meet the functionality of the existing systems. Additional information may be found in the appended safety evaluations for each HMI.

- c. Describe how the software and hardware were integrated; and discuss how UML verifies the required computer system software is installed in the appropriate system configuration, and how UML ensures that the correct version of the software/firmware is installed in the correct hardware components, to verify operability.

### **Response to RAI 7.2c**

The HMI systems were physically integrated into the existing systems by both the contractor and the operations staff. Acceptance checklists were developed to test the operability of the displays and controls. The reactor checkout procedure and pre-critical checklists were updated where needed. Operations staff at the time were provided training specific to the OPTO22 hardware and software, in addition to use of the HMI. Additional information may be found in the appended safety evaluations for each HMI. Firmware and software configurations are not checked as part of a routine surveillance program. The operability of the HMI are verified and documented as part of the pre-critical checkout procedure.

- d. Identify the developer of the integrated systems software/hardware for the PCS, DCS, and ARMS and describe the verification and validation (V&V) or other testing performed to assure software operability and reliability.

### **Response to RAI 7.2d**

The ARMS HMI system was developed and installed by Artisan Industries, Waltham, MA. The PCS HMI system was developed and installed by Martindale Associates, Haverhill, MA. The DCS HMI system was developed and installed by Controlled Environment Structures, Mansfield, MA. Controlled Environment Structures also developed and installed the HMI systems for the RINSC reactor.

The validation and verification efforts associated with the HMI are same that described in RAI response 7.2b. The validation process to assure functional requirements were met was performed through site visits and iterative communications with the contractors. The verification process to assure HMI performed as intended was performed using specifically developed checklists for each system. In addition, prior to operation of the reactor with each of the systems, the applicable technical specification surveillances (e.g., calibrations) were performed in addition to the required pre-critical operational tests and checks of the reactor control and protections systems.

### **RAI-7.3**

The regulations in 10 CFR 50.59 state, in part, that a licensee may make changes to the facility and procedures as described in the SAR if the licensee makes a determination (documented in a written evaluation) that no TS change is required, and that the changes do not meet any of the criteria in 10 CFR 50.59(c)(2). Section 50.34(b)(4) of 10 CFR requires a final analysis and



evaluation of the design and performance of SSCs and taking into account any pertinent information developed since the submittal of the preliminary safety analysis report.

Table 1-5 of the UMLRR SAR lists facility modifications since the last renewal for which UML states a 10 CFR 50.59 review was performed to ensure that a license amendment was not required. However, the NRC staff notes that Table 1-5 does not appear to include some 10 CFR 50.59 reviews that are described elsewhere in the SAR or in annual reports. Specifically, SAR Section 7.6.1.1 states that the ARMS was installed in 1999 under 10 CFR 50.59. Additionally, the 2009-2010 annual report (ADAMS Accession No. ML102460026) and the 2015-2016 annual report (ADAMS Accession No. ML16224A324) for the UMLRR describe changes related to 10 CFR 50.59, including drives control system, and control room annunciator panel replacement, respectively (the NRC staff notes that the annunciator panel replacement may have been reviewed/implemented after the 2015 SAR was submitted).

Additionally, it is not clear to the NRC staff that all of the 10 CFR 50.59 reviews that appear to be relevant to the current UMLRR I&C system, are fully described in the SAR, as supplemented. For example, upgrades to drive position are described in the SAR, but these do not appear to be the same changes that are indicated in the 2003, "Drives Control System," change listed in SAR Table 1-5.

Provide the following, or justify why no additional information is required:

- a. Clarify whether SAR Table 1-5 provides a complete list of 10 CFR 50.59 reviews, and if necessary, provide a revised and updated list of 10 CFR 50.59 reviews since the previous license renewal, which includes items discussed elsewhere in the SAR and/or in annual reports, as appropriate. Also, clarify whether the items in the list received a full 10 CFR 50.59 review and written evaluation, or whether some items in the list were reviewed for 10 CFR 50.59 applicability, but were determined to screen out of needing a full review (based on the NRC staff's review of UMLRR annual reports, it appears that UML may have determined that some of the items listed in SAR Table 1-5 screened out). Additionally, clarify whether the items in the list have all been implemented, or whether the list includes items that were reviewed but not implemented (e.g., SAR Table 1-5 includes a "Linear Channel Replacement," in 2014, but it is not clear whether this is the channel replacement that UML is requesting that the NRC review in conjunction with its renewal request, or a different change that has already been implemented).

### **Response to RAI 7.3a**

The draft SAR Table 1-5 has been revised to include the type of review and whether the review was implemented. The original Table 1-5 inadvertently did not include one of two reviews that occurred in 2010. Note that in 2010, a formal procedure was developed based on the guidance in NEI 96-07, Rev.1. Prior to that, all the 10CFR 50.59 reviews for the UMLRR were done as full evaluations. Prior to 2016, procedure changes were not formally evaluated under the 50.59 process, but were reviewed by the reactor safety committee in accordance with the current TS 6.2.2.c. The 50.59 procedure was revised in December 2015 to include facility procedures. All the changes reviewed in the revised Table 5-1 have been implemented with the exception of the power monitoring channels (Linear Channel Replacement 2014 and Log-N Channel Replacement 2013).

Revised Table 5-1

YEAR	TITLE	TYPE	REVIEWED	Implemented
2019	Procedure FP-4 Revision	Screen	06/06/2019	Yes
2016	Annunciator Replacement	Screen	03/30/2016	Yes
2015	Center Flux Trap Replacement	Screen	06/11/2015	Yes
2015	Control Blade Replacement	Screen	03/18/2015	Yes
2014	Linear Channel Replacement	Screen	12/17/2014	No
2014	Addition of Panel Indicators	Screen	10/07/2014	Yes
2013	Log-N Channel Replacement	Screen	12/18/2013	No
2013	Beamport Irradiation Facility	Screen	06/25/2013	Yes
2012	Stack Monitor Replacement	Screen	12/21/2012	Yes
2012	Cooling Tower Replacement	Screen	03/29/2012	Yes
2012	Chart Recorder Replacement	Full	01/12/2012	Yes
2011	Pneumatic Tube Control System Upgrade	Screen	09/29/2011	Yes
2010	Upgrades to Drive Control System	Screen	03/29/2010	Yes
*2010	Reactor Test Using Down-comer Flow Mode	Screen	02/25/2010	Yes
2008	Secondary Cooling System Remote Control	Full	03/14/2008	Yes
2003	Drives Control System	Full	02/20/2003	Yes
2002	Clean-up and Make-up System Upgrade	Full	04/11/2002	Yes
2001	Upgrade of UMLRR Process Control Cabinet	Full	10/25/2001	Yes
2001	Ex-Core Fast Neutron Irradiation Facility	Full	01/17/2001	Yes
2000	ARM Upgrade	Full	02/23/2000	Yes
1998	Power Detector Mechanical Height Adjusters	Full	12/17/1998	Yes
1997	NI & ARM Upgrade	Full	09/11/1997	Yes

\*Procedure AP-6 "10CFR 50.59 Screenings and Evaluations" implemented.

- b. Provide copies of the 10 CFR 50.59 reviews (or screens) listed in RAI Table 7-1 below, to allow the NRC staff to effectively evaluate the current I&C system for license renewal. Additionally, provide copies of the 10 CFR 50.59 reviews (or screens) for any other modifications to the facility since the last license renewal that UML determines could impact the current (or proposed) UMLRR I&C systems, if any. Alternatively, provide a detailed evaluation and discussion of the changes listed below (and any other relevant changes), including descriptions of any modification or addition to, or removal from, the facility or procedures that affects the I&C system design function, or method of performing or controlling the function; and, their impact on UMLRR operations.

### Response to RAI 7.3b

The RAI Table 7-1 is inclusive of the facility changes associated with I&C. The requested 50.59 reviews are included in the appendix B of this response.

- c. During the Audit, the NRC staff reviewed a 10 CFR 50.59 screen numbered 16-01 related to the addition of control room alarms and indicators. Clarify whether this screen is the same as the "Control Room Annunciator Panel Replacement" (discussed in the 2015-2016 annual report) item listed in RAI Table 7-1 below. If 16-01 is a different screen, provide the information requested in RAI-7.3 a. and b. above.

<b>RAI Table 7-1: UMLRR 10 CFR 50.59 Reviews (or Screens)</b>		
<b>Year</b>	<b>Title</b>	<b>Reviewed</b>
2016†	Control Room Annunciator Panel Replacement*	?
2014	Linear Channel Replacement	12/17/2014
2014	Addition of Panel Indicators	10/7/2014
2013	Log-N Channel Replacement	12/18/2013
2012	Chart Recorder Replacement	01/12/2012
2010†	Drives Control System*	?
2008	Secondary Cooling System Remote Control	03/14/2008
2003	Drives Control System	02/20/2003
2001	Upgrade of UMLRR Process Control Cabinet	10/25/2001
1999	ARMS Upgrade**	?
1998	Power Detector Mechanical Height Adjusters	12/17/1998
1997	Instrumentation Upgrade	09/11/1997

† Estimated date (actual date unknown)

\* Discussed in UMLRR Annual Reports

\*\* Discussed in Section 7.6.1.1 of the UMLRR SAR

### **Response to RAI 7.3c**

The screen numbered 16-01 reviewed in audit is the same as the “Control Room Annunciator Panel Replacement” listed in Table 7-1, and as listed as “Annunciator Replacement” in revised Table 5-1.

### **RAI-7.4**

The regulations in 10 CFR 50.9, “Completeness and accuracy of information,” require that information provided to the Commission by an applicant for a license or by a licensee or information required by statute or by the Commission's regulations, orders, or license conditions to be maintained by the applicant or the licensee shall be complete and accurate in all material respects. The regulations in 10 CFR 50.30(b) “Oath or affirmation,” require that license applications, and each amendment to such applications, must be executed in a signed original by the applicant or duly authorized officer thereof under oath or affirmation. By letter dated July 26, 2017 (ADAMS Accession No. ML17249A080), GA submitted, to the NRC, a request for withholding of information from public disclosure under 10 CFR 2.390, “Public inspections, exemptions, requests for withholding,” for documents related to its NMP-1000 Multi-Range Linear Module. GA’s letter stated that these documents were being submitted in support of licensing requests, planned or pending, with the NRC initiated by UML. The request for withholding was granted to GA by letter dated December 7, 2018 (ADAMS Accession No. ML18338A040). However, the NRC requires that all design documentation to be considered by the NRC staff in the licensing determination for the UMLRR I&C upgrade be on the UML docket.

Provide the following, or justify why no additional information is required:

- a. During the Audit, the NRC staff reviewed available documentation regarding the design criteria and bases for the GA NMP, NLW, and NLX systems; however, this documentation is proprietary, and this GA documentation indicates that it is

documentation prepared for another facility. Indicate which, if any, of the below documents are applicable, and the extent of their applicability to the UMLRR I&C install:

- 1) T3322000-1AT\_Rev A NLW-1000 Acceptance Test Procedure
- 2) T3322000-RTM\_Rev A NLW-1000 Traceability Matrix – easy read
- 3) T3322000-RTM\_Rev A NLW-1000 Traceability Matrix
- 4) T3401000-1AT\_Rev A NMP-1000 Acceptance Test Procedure
- 5) T3401000-RTM\_Rev A NMP-1000 Traceability Matrix – easy read
- 6) T3401000-RTM\_Rev A NMP-1000 Traceability Matrix
- 7) T9S900D940-SYR\_Rev A NMP-1000 System Requirements Specification (SyRS)
- 8) T9S900D941-SRS, NMP-1000 Software Requirements Specification (SRS)
- 9) T9S900D950-SYR\_Rev A NLX-1000 SyRS
- 10) T9S900D951-SRS, NLX-1000 SRS
- 11) T9S900D980-FME Rev A, NMP-1000 Failure Modes Effects Analysis
- 12) 20130207001-RPT Rev 2, NetBurner-MOD54415 Validation Summary Report
- 13) LPC E117-1017 Rev 1, NMP1000 operations and maintenance manual
- 14) T3401000-1UMB, NMP-1000 user manual

#### **Response to RAI 7.4a**

The only GA documentation applicable to review would be associated with the NMP-1000. The NLW and NLX systems do not apply. Of the documents listed above, items 4, 5, 6, 7, 8, 11, 12, 13, and 14 would apply to the review associated with the NMP1000.

- b. Additionally, to meet the requirements of 10 CFR 50.9, 10 CFR 50.30, and 10 CFR 2.390, submit, under oath or affirmation, a request for the above documentation (listed in RAI-7.4.a) to be placed, as applicable, on the 50-223 docket with reference to the affidavit from the content owner justifying withholding stating the above documentation applies to the renewal of Facility Operating License No. R-125.

#### **Response to RAI 7.4b**

The documentation as noted in the Response to RAI 7.4a is hereby requested under oath and affirmation to be included on the 50-223 docket for use in the renewal of license R-125. An affidavit related to 10 CFR 2.390 has been submitted separately to the NRC by General Atomics for items 1 through 12 listed in RAI 7.4a.

- c. During the Audit, the NRC staff identified additional information that is necessary for the NRC staff to reach a licensing decision. Some of the documentation listed above (e.g., item 13 and 14) may be necessary for the NRC review, but was not submitted under the GA affidavit dated July 26, 2017. Submit a copy of that documentation under oath or affirmation, along with a 10 CFR 2.390 affidavit signed by the content owner (if appropriate).

#### **Response to RAI 7.4c**

An affidavit from GA for the item 13 and 14 documents has been requested. In an electronic communication to UMLRR staff dated 10/09/2019, GA has indicated another 60 days is needed

for the submittal. A 60 day extension request for RAI 7.4c has been requested in the associated cover letter for these RAIs.

- d. During the Audit and in a supplement to its license renewal application (ADAMS Accession No. ML19100A273), UML proposed a replacement for the Log Power Measuring Channel, which uses the Thermo Scientific PPM to replace the existing GA wide-range logarithmic power module. Provide similar documentation for the proposed PPM commensurate with the GA documentation referenced in 7-4.a above (e.g., Thermo Scientific Ex-core Neutron Flux Monitoring System Instruction Manual: 937 Wide Range Signal Processor Document number 937 Revision, and similar design, operations, and maintenance documentation).

### **Response to RAI 7.4d**

TFS has provided the UMLRR with the following documents for reference and audit purposes associated with the PPM: (1) Neutron Flux Monitoring Systems Instruction Manual:1126 for UMASS Lowell. The manual is proprietary. (2) Quality Assurance Program Manual Rev. 22. This document states the TFS Nuclear Systems and Services products meet the objectives of 10CFR 50 Appendix B and ANSI/ASME NQA-1-2000 & 2008-09a. Other documents include the Certificate of Conformance, Configuration Record, and Test Reports for the PPM. Item 2 and the other documents are not marked proprietary and are submitted as part of this RAI.

An affidavit from TFS for the applicable documentation has been requested. A 60 day extension request for RAI 7.4d has been requested in the associated cover letter for these RAIs.

### **RAI-7.5**

The regulations in 10 CFR 50.34(b)(2) require that the SAR contain a description and analysis of the SSCs of the facility, with emphasis upon performance requirements; the bases, with technical justification therefor, upon which such requirements have been established; and the evaluations required to show that safety functions will be accomplished. The description shall be sufficient to permit understanding of the system designs and their relationship to safety evaluations. Items such as I&C systems shall be discussed so far as they are pertinent.

The guidance in NUREG-1537, Part 2, Section 7.4, states that, “[h]ardware and software for computerized systems should meet the guidelines of [Institute of Electrical and Electronics Engineers] (IEEE) 7-4.3.2-1993.” IEEE Standard 7-4.3.2-2010, Clauses 5.3, 5.3.1, 5.3.5, and 5.3.4, recommend that the development and the integration of computer hardware and software be addressed in the development process, including software QA and the use of software quality metrics to assess whether software quality requirements are being met throughout the system lifecycle, V&V activities, and configuration management to ensure changes to the software/firmware are formally documented and approved.

Section 1.4.3 of the “NMP-1000 Software Requirements Specification, T9S900D941-SRS,” references several GA-EIS documents including the software QA plan, software V&V plan, and other documents. Section 3.6.4.1 of the “NMP-1000 System Requirements Specification, T9S900D940-SYR” (item No. 7 listed in RAI-7.4.a above), states that, “[s]oftware configuration

shall be formally controlled according to the Software Configuration Management Plan.” However, the details of these plans for the NMP-1000 are not clear from the SAR or other information submitted in support of license renewal. Additionally, similar design-specific documentation does not appear to have been provided for other I&C upgrades proposed in conjunction with license renewal (e.g., Thermo Scientific Wide Range Log PPM).

Provide the following, or justify why no additional information is required:

- a. Provide the specific vendor plans (e.g., those listed above), or reference to the vendor’s process certifications to ensure conformance to industry standards on software QA (such as the International Organization for Standardization (ISO) 9000 or a process level improvement model, such as Capability Maturity Model Integration (CMMI)), that document the formal process for the NMP-1000 upgrades that describes the software development through the system lifecycle to ensure software quality and configuration management. Alternatively, provide equivalent details on UML processes and plans that similarly demonstrate software quality and configuration management.

### **Response to RAI 7.5a**

In addition to the documents noted in RAI Response 7.4a, GA has provided the UMLRR with three additional documents for audit purposes (all proprietary): (1) “TRIGA INL Software Configuration Management Plan T9S900D970-CMP”. This document references IEEE Std 828 IEEE Standard for Software Configuration Management Plans 2005 and NQA-1-2000 ANSI/ASME Quality Assurance Requirements for Nuclear Facility Applications. (2) “TRIGA INL Channels Software Development Plan TT9S900D970-SWP-2A”. This document references IEEE 1058-1998 IEEE Standard for Software Project Management Plans and NQA-1-2000 ANSI/ASME Quality Assurance Requirements for Nuclear Facility Applications. (3) “Software Quality Assurance Plan TS900SQAP-B”. This procedure references NQA-1-2000 ANSI/ASME Quality Assurance Requirements for Nuclear Facility Applications, various applicable IEEE standards, in addition to 10CFR 50 Appendix B and applicable NRC Reg Guides. An affidavit from GA for these documents has been requested. In an electronic communication to UMLRR staff dated 10/09/2019, GA has indicated another 60 days is needed for the submittal. A 60 day extension request for RAI 7.5a has been requested in the associated cover letter for these RAIs.

- b. Provide similar design-specific documentation for all other proposed I&C upgrades (e.g., Thermo Scientific Wide Range Log PPM). Appropriate documentation may be of the types listed below. (Note: the below list is typical vendor information of the type that would aid in the NRC staff review. However, these are examples and not necessarily indicative of actual required documents.)
  - Software Development Plan (SDP)
  - Software Configuration Management Plan (SCMP)
  - Software Quality Assurance Plan (SQAP)
  - Software Integration Plan (SIntP)
  - Software Installation Plan (SInstP)
  - Software Maintenance Plan (SMaintP)
  - Software Safety Plan (SSP)
  - Software Verification and Validation Plan (SVVP)
  - Software Configuration Management Plan (SCMP)
  - Software Test Plan (STP)

**Response to RAI 7.5b**

The PMM is composed entirely of analog circuitry. Please see also response to RAI 7.4d.

**RAI-7.6**

The regulations in 10 CFR 50.34(b)(2) require that the SAR contain a description and analysis of the SSCs of the facility, with emphasis upon performance requirements; the bases, with technical justification therefor, upon which such requirements have been established; and the evaluations required to show that safety functions will be accomplished. The description shall be sufficient to permit understanding of the system designs and their relationship to safety evaluations. Items such as I&C systems shall be discussed so far as they are pertinent.

The guidance in NUREG-1537, Part 2, Section 4, states that ANSI/ANS 15.20 is useful as general guidance for the design, implementation, and evaluation of I&C systems. Clauses 9.3, 9.3.1, and 9.3.2 of ANSI/ANS 15.20 state that verification is used during software development to facilitate elimination of errors in computer-based systems, and that a key ingredient in the validation process is sufficient independence of the review team. NUREG-1537, Part 2, Section 7.4, states that, “[h]ardware and software for computerized systems should meet the guidelines of IEEE 7-4.3.2-1993.” Clauses 5.3.3 and 5.3.4 of IEEE Standard 7-4.3.2-2010 state that the V&V process applies to both hardware and software. However, the details of V&V for the proposed I&C upgrades are not clear to the NRC staff from the SAR or other information submitted in support of license renewal.

Describe any V&V performed for the NMP-1000 modules, Thermo Scientific PPM, and other proposed I&C upgrades. Additionally, provide documentation that shows the plan for the V&V and V&V procedures, and when available, the results confirming V&V has been successfully accomplished. These documents should demonstrate that the proposed I&C systems meet the design requirements and specifications, and that it fulfills its intended purpose. The V&V testing should also show that the test plan and test results, including any deviations, required corrective actions, and retests were reviewed by the Reactor Safety Subcommittee (RSSC) and reviewed and approved by UMLRR Reactor Supervisor. Alternatively, discuss why no additional information is required.

**Response to RAI 7.6**

The current UMLRR TS 4.2.6 & 7 requires that any reactor safety system (RSS) instrument channel replacement must have undergone a channel check prior to installation, and must undergo a channel calibration before routine operation of the reactor after channel installation and, any RSS instrument repaired or replaced while the reactor is shutdown must have a channel test prior to reactor operation. In addition, TS 6.2c requires the RSSC review and approval of proposed changes to the facility systems or equipment, procedures, and operations. Similar requirements are included in the proposed TS for relicensing (TS 4.0B and TS 6.2.3).

Draft surveillance documents for the GA NMP1000 linear channel are provided in Appendix C to this response. Surveillance documents for the TFS PPM are incomplete. The TFS test report noted in RAI Response 7.5b is has an extensive acceptance procedure and test results from the manufacturer. Chapter 5 of the TFS operations manual provides surveillance and calibration procedures. This information was recently received by UMLRR from TFS is now being used to

establish the UMLRR test and calibration procedures for the instrument. The procedures will be similar in scope and detail to those provided for the GA NMP1000.

### **RAI-7.7**

The regulations in 10 CFR 50.34(b)(2) require that the SAR contain a description and analysis of the SSCs of the facility, with emphasis upon performance requirements; the bases, with technical justification therefor, upon which such requirements have been established; and the evaluations required to show that safety functions will be accomplished. The description shall be sufficient to permit understanding of the system designs and their relationship to safety evaluations. Items such as I&C systems shall be discussed so far as they are pertinent.

The guidance in NUREG-1537, Part 2, Section 7.4, states that, “[h]ardware and software for computerized systems should meet the guidelines of IEEE 7-4.3.2-1993.” IEEE Standard 7-4.3.2-2010, Clause 5.3.5, states that, “[c]hanges to the software shall be formally documented and approved consistent with the software configuration management plan.” Software configuration management (CM) should include a determination that any software modifications, including firmware, during the design process, and after acceptance of the software for use, will be made to the appropriate version and revision of the software. However, the details of software CM for the proposed I&C upgrades are not clear from the SAR or other information submitted in support of license renewal.

Describe how software changes after initial delivery will be reviewed, tracked and documented. Additionally, provide documentation that a configuration management program appropriately traces changes to safety system software—from their point of origin to implementation—and addresses any impacts on system safety, control console, or display instruments. Alternately, explain why configuration control is not required, or discuss why no additional information is required.

### **Response to RAI 7.7**

A configuration management program shall be implemented as part of this relicensing. The configuration management program shall incorporate the following requirements:

Any change in either the hardware or software configuration of the UMLRR Limiting Condition of Operation (LCO) required equipment shall be treated as a facility design change and subject to 10CFR 50.59 review as required by (proposed) Technical Specification (TS) 6.2.3. The 10CFR 50.59 review shall be performed and documented in accordance with the approved UMLRR administrative procedure governing such reviews. As required by TS 4.0B the applicable surveillance testing shall be conducted after replacement, repair, or modification before the equipment is considerable operable and returned to service. The surveillance shall be done in accordance with the approved UMLRR surveillance procedure for the equipment. Operations personnel shall receive training on the hardware or software change and such training shall be documented. A log of the current configuration of LCO equipment software shall be documented and maintained in the control room. The LCO equipment software version shall be checked and verified against the configuration log during the TS calibration for the equipment.\* For a discrepancy, the equipment shall be taken out of service and shall be immediately reported to the TS Level 2.



\* Note: LCO equipment software/firmware changes are not readily accomplished and normally would be performed by the manufacturer. If the manufacturer should neglect to communicate a change was made during service or repair, the surveillance required by TS 4.0B and the UMLRR Configuration Management Program would determine if the software/firmware version number has changed, triggering a review.

### **RAI-7.8**

The regulations in 10 CFR 50.34(b)(2) require that the SAR contain a description and analysis of the SSCs of the facility, with emphasis upon performance requirements; the bases, with technical justification therefor, upon which such requirements have been established; and the evaluations required to show that safety functions will be accomplished. The description shall be sufficient to permit understanding of the system designs and their relationship to safety evaluations. Items such as I&C systems shall be discussed so far as they are pertinent.

The guidance in NUREG-1537, Part 2, Section 7.4, states that, “[h]ardware and software for computerized systems should meet the guidelines of IEEE 7-4.3.2-1993.” IEEE Standard 7-4.3.2-2010, Clause 5.11, states that, “[s]oftware and hardware identification, including version control, shall be provided and used to verify that the correct software is installed in the correct hardware component.” The digital computer system equipment for the displays and processor—including hardware, software, firmware, and interfaces—should be reviewed to provide assurance that the required computer system hardware and software are installed on the appropriate system configuration. However, the details of how this will be done for the proposed I&C upgrades does not appear to be provided in the SAR or other information submitted in support of license renewal.

- a. Provide a description of any applicable program or procedure used to ensure that the correct version of the software is installed on the NMP-1000 modules and demonstrate assurance that the required computer system hardware and software are installed in the appropriate system configuration, including a program to ensure that the correct version of the software/firmware is installed in the correct hardware components (i.e., as part of the reactor startup checklist procedure to verify operability).
- b. During the Audit, UML staff confirmed the NRC staff observation that the NMP-1000 user manual stated that GA would do all software installs. Explain how UML will verify the version of the software install is correct, and how UML will validate that any updates are correct for the UMLRR, including any updates to the programs and procedures addressed in RAI 7.8.a.

### **Response to RAI 7.8a&b**

Please see response to RAI 7.7.

### **RAI-7.9**

The regulation in 10 CFR 50.34(b)(6)(iv) states, in part, that the final safety analysis report shall include plans for conduct of normal operations, including maintenance, surveillance, and periodic testing of SSCs. The regulation in 10 CFR 73.40, “Physical protection: General requirements at fixed sites,” requires that licensees provide physical protection at a fixed site, or contiguous sites where licensed activities are conducted, against radiological sabotage, or against theft of special nuclear material, or against both.

The guidance in NUREG-1537, Part 2, Section 4, states that the guidance in ANSI/ANS-15.15-1978 is useful as general guidance for the design, implementation, and evaluation of I&C systems. The guidance in ANSI/ANS-15.15-1978, Clause 5.10, states that physical provisions shall be provided to prevent the unauthorized use of the reactor controls and limit access to setpoint and calibration adjustments to the extent necessary to prevent inadvertent misadjustments. Access control includes cyber security vulnerabilities (physical and electronic), including preventing/limiting unauthorized physical and electronic access during the developmental or operational phase and the transition from development to operations.

During the Audit, the NRC staff reviewed the NMP-1000 user manual and observed that, unless disabled or administratively controlled, the NMP-1000 modules can accept commands via the Ethernet port (J9 connector) or the analog remote interface connector on the rear panel (J8 connector). The J8 connection uses an RS-232 cable remote display and a null-modem cable connected to a PC for maintenance.

- a. During the Audit, UML staff indicated that the Ethernet connection (J9) will not be used. However, when the UML staff removed the NMP-1000 outer case, the NRC staff observed that the ethernet capabilities were not disabled (i.e., the cord was still attached). Verify that the maintenance connection (J8) and the ethernet connection (J9) will not be used, that the internal cable connector for J9 was removed, and state how this configuration will be assured.

### **Response to RAI 7.9a**

The J8 and J9 connectors are for communications with a TRIGA console that UMLRR does not possess. The UMLRR does not possess the software tools for communications with the NMP1000 via those connections. As an additional conservative measure, the wiring to both the J8 and J9 connections within the instrument chassis have been disconnected by UMLRR staff for both NMP1000 units. The approved UMLRR calibration procedure for the NMP1000 shall include a procedural step to verify J8 and J9 are disconnected when the instrument chassis is opened for calibration or maintenance purposes.

- b. During the Audit, UML staff stated that GA will perform any and all maintenance on the NMP-1000s. Explain how UML staff will ensure configuration management will be maintained, and how necessary post-maintenance testing will be performed. Additionally, discuss the UML staff's role in verifying and approving the test results are acceptable prior to resuming operations with a channel on which GA has performed maintenance to ensure TS-required operability.

### **Response to RAI 7.9b**

To clarify, the UMLRR staff will perform calibrations of the NMP1000 and simple repairs where practical. Where repairs cannot be made, or the unit will not calibrate or perform as intended, the unit would be sent back to manufacturer. Please see response to RAI 7.7 should such instances occur.

- c. During the Audit, UML staff also indicated that the remote interface push button is for use in a GA console, which the UMLRR does not have. The UML staff stated that pushing the remote interface push button disables the ability to reset a scram. Explain how

UML will ensure that the remote input to the NMP-1000 modules will not be used to provide commands to the NMP-1000 modules.

### **Response to RAI 7.9c**

The remote interface pushbutton is associated with the TRIGA console that the UMLRR does not have. The previous version of NMP1000 (currently in use at the UMLRR) also has this feature. Pressing the button will open the scram relay on the unit. As part of the checkout procedure (currently and for the new version NMP1000), the operator verifies the switch is in the off position.

### **RAI-7.10**

The regulations in 10 CFR 50.34(b)(2) require that the SAR contain a description and analysis of the SSCs of the facility, with emphasis upon performance requirements; the bases, with technical justification therefor, upon which such requirements have been established; and the evaluations required to show that safety functions will be accomplished. The description shall be sufficient to permit understanding of the system designs and their relationship to safety evaluations. Items such as I&C systems shall be discussed so far as they are pertinent. The regulations in 10 CFR 50.34(b)(6)(iv) state, in part, that the final safety analysis report shall include plans for conduct of normal operations, including maintenance, surveillance, and periodic testing of SSCs. Additionally, the regulations in 10 CFR 50.9 require that information provided to the Commission by an applicant for a license or by a licensee, or information required by statute or by the Commission's regulations, orders, or license conditions to be maintained by the applicant or the licensee, shall be complete and accurate in all material respects.

Provide the following, or justify why no additional information is required:

- a. During the Audit, the NRC staff reviewed UML 10 CFR 50.59 screen 16-01 related to the addition of control room alarms and indicators, and also observed that the additional alarms and indicators were added in the control room (the additional alarms and indicators are on a new/replaced control room annunciator panel). The control room instrument panel, which is separate from the control console, houses the control room annunciator panel. The NRC staff observed that the new annunciator panel is a 5 x 5 panel (i.e., laid out with 5 rows of indicator spaces with 5 indicator spaces each).

The NRC staff also reviewed the UMLRR 2015-2016 annual report, which describes an annunciator panel upgrade performed by UML without prior NRC review or approval (see also RAI-7.3). The annual report states that the original panel had 17 individual alarm indicators (2 by 3 inches each), while the new panel has 23 indicators (2.25 by 2.75 inches each); 6 additional alarm indicators were added to provide additional information for the operator. The annual report also states that the new alarm panel performs the same function as the old panel, but the new panel uses more reliable technology (light-emitting diodes rather than incandescent lights). The annual report states that “[t]he indicators are slightly larger and have the same physical location in the control room.”

The control room annunciator panel is labelled P-22 in SAR Figure 7-8, as well as in updated Figure 7-9 in UML’s supplemental information dated April 10, 2019 (ADAMS

Accession No. ML19100A273). SAR Figure 7-8 shows a 4 x 4 panel. SAR Section 7.4.4 lists 16 alarm conditions, and SAR Table 7-7 states that the alarm panel “[p]rovides annunciator buzzer and annunciator lights for 16 monitored conditions.” Updated SAR Figure 7-9 in UML’s supplemental information dated April 10, 2019, also shows a 4 x 4 panel.

- i. Given that the SAR, as supplemented, appears to the NRC staff to describe the old control room annunciator panel instead of the new panel, provide updated SAR section(s) or detailed descriptions reflecting the new 5 x 5 panel and the additional information provided to the operator that was not available with the old 4 x 4 panel. Include a discussion of the additional alarm indicators included on the new panel.

### Response to RAI 7.10a(i)

The 2015 draft SAR 7.4.4 “Alarm and Indicator System” is the same description as provided in section 4.4.16 of the 1985 FSAR as the alarm panel had not been upgraded at the time of the 2015 draft SAR. In addition to the existing alarm indicators noted in the draft SAR, the upgrade in 2016 added 5 new indicators useful to the operator. One existing alarm indicator that had two conditions was separated into two indicators (demineralizer high temperature and low flow). The Final SAR 7.4.4 shall be revised to read as follows (red indicates new text):

~~The alarm system is divided into two sections: one for coolant variables and the other for nuclear variables. The section used for cooling system alarm will be operative with forced cooling.~~ **The alarm system provides indicators of the reactor mode, reactor conditions, coolant conditions, and building conditions.** When an abnormal condition develops, a buzzer sounds and the appropriate light goes on. The operator may press the acknowledge button to silence the buzzer. When the alarm condition is corrected, the light may be reset. The following conditions will actuate the alarm and indicator system:

- Short period
- High neutron flux
- Safety chain scram
- Blade disengaged
- Low pool level
- Bridge unlocked
- Access doors open
- Coolant gates open
- Seismic trip
- Low coolant flow (2 sensors)
- High coolant temperature (3 sensors)
- High conductivity
- High voltage failure
- Regulating blade at limit
- Reactor core low flow
- Demineralizer high temperature ~~and low flow~~
- Demineralizer low flow**

Building Pressure  
Low Secondary Flow  
Pump Room Sump  
pH Limit  
Natural Convection Mode

(End of 7.4.4)

Separating the demineralizer high temperature and low flow is self-explanatory and provides the operator information as to which condition is causing the alarm, where before either condition would activate the one alarm indicator. Building Pressure provides the operator an indication that building pressure is not negative which is useful to assure confinement conditions are being met. Building pressure was and still is checked prior to start-up and at four intervals during reactor operation. Low Secondary Flow provides the operator a useful indication there is a problem with the secondary coolant system. The secondary coolant system status was and still is checked hourly during reactor operations. Pump Room Sump provides a useful indication that the basement sump level is high and needs to be pumped before an overflow occurs. The pump room sump was and still is checked prior to start-up and at 4 hour intervals during reactor operation. The pH Limit provides useful information to the operator as limits for pH will be a new TS requirement. The pH was and still is checked prior to reactor operation. Natural Convection Mode provides a more visible indication to the operator that the reactor operation is limited to 100kW. Prior to this indicator a small LED indicator light was, and still is available on the control console.

The draft SAR Figure 7-9 provides an illustrative indication of instrument locations and is not intended as an exact depiction of instrument configurations. However, for clarity Figure 7-9 will be updated in the Final SAR to more accurately depict the current annunciator configuration.

- ii. The NRC staff noted that there appear to be discrepancies in the descriptions of the old and new annunciator panels based on the information in the SAR, as supplemented; information in the 2015-2016 annual report; and the NRC staff's observations during the Audit. Explain why the SAR, as supplemented, appears to state that the old panel monitored 16 alarm conditions, but the annual report appears to state that the old panel monitored 17 conditions. Clarify why the new panel only has 23 indicators, if it is a 5 x 5 panel with 25 indicator spaces (e.g., because 2 spaces are unused, if this is the case). Also, explain the statement in the annual report that the new indicators are slightly larger, given that the dimensions provided for the new indicators appear to be smaller. Additionally, if there are any discrepancies or differences between the 10 CFR 50.59 screen 16-01 (requested in RAI-7.3) and the annual reports or the SAR, as supplemented, explain these discrepancies.

### Response to RAI 7.10a(ii)

The document discrepancies regarding the actual number of indicators stems from the original alarm panel having 16 functional indicators (i.e., lighted square panels) of which one of the indicators had two alarm conditions associated with it – i.e., 17 alarm conditions (see Response to RAI 7.10(i)). The old panel also had an unused indicator labeled as “High Radiation” that was never wired to an alarm output. Radiation alarms are indicated on the Area Radiation Monitoring cabinet in the control room. The 1985 FSAR (and subsequent 2015 draft SAR) did not include mention of the unused “High Radiation” indicator. However, the 50.59 screen for the new annunciator noted there were 17 indicators on the original panel and 6 new alarms being added to the new panel. This may have caused confusion when the annual report was drafted from the information provided in the 50.59 screen ( $17 + 6 = 23$ ). To confirm, the new panel installed in 2016 presently has 22 alarm indicators in use for the alarm conditions noted in Response to RAI 7.10a(i) and two unused indicators. The 25th space is occupied by a local alarm acknowledge switch. The statement regarding indicator size in the annual report is considered correct. As noted on the 50.59 screen and in the annual report, the previous indicators were 2”x3” ( $6\text{in}^2$ ). The new indicators are 2.25” x 2.75” ( $6.2\text{in}^2$ ).

- b. The guidance in NUREG-1537, Part 2, Section 7.4, states that, “[h]ardware and software for computerized systems should follow the guidelines of IEEE 7-4.3.2-1993.” IEEE Standard 7-4.3.2 provides guidance to address system design risks created by human errors in the operation and support of the system. To determine if the human-system interface (HSI) aspects of a display modification have an adverse effect on SAR-described design functions, potential impacts due to the number and/or type of parameters displayed by and/or available from the HSI should be evaluated. Consideration of a digital modification's impact due to the number and/or type of parameters displayed by and/or available from the HSI should involve an examination of the actual number and/or type of parameters displayed by and/or available from the HSI and how they could impact the performance and/or satisfaction of SAR-described design functions. An increase in the amount of information that is provided such that the amount of available information could have a detrimental impact on the operator's ability to discern a particular condition or to perform a specific task. The evaluation should also consider logical grouping and relevance.

Provide an evaluation that considers the HSI impact of the additional indicators, and that addresses potential hazards created by human errors in the operation of the system to assure that the functions allocated in whole or in part to the human operator(s) and maintainer(s) can be successfully accomplished to meet the safety system design goals. Include an explanation of any changes made in procedures or operating instructions to mitigate the potential adverse impact.

### Response to RAI 7.10b

The IEEE Standard 7-4.3.2-1993, *Standard Criteria for Digital Computers in Safety Systems of Nuclear Power Generating Stations* section 5.14 *Human Factor Considerations* refers the user to IEEE Std 603-1991. The IEEE Standard 603-1991, *Standard Criteria for Safety Systems for Nuclear Power Generating Stations* states the following in section 5.14: “*Human factors shall be considered at the initial stages and throughout the design process to assure that the functions*

*allocated in whole or in part to the human operator(s) and maintainer(s) can be successfully accomplished to meet the safety system design goals, in accordance with IEEE Std 1023-1988.”*

While the referenced standards are applicable to nuclear power reactors, the process noted in section 5.14 above was generally undertaken for the new UMLRR annunciator panel. During the design phase for procurement, when it became apparent that additional alarm indicators could be made available, the operators at that time were consulted as to what additional information would be useful. The operator opinions were used in making the choices for the new indicator alarms. The operators were already aware of the existence and the parameters for each of the newly added alarm conditions as part of their knowledge-based training for the facility. Having the added alarms in the control room was and is considered a positive improvement by the operators. The additional indicators have no adverse impact on operator performance. While there is no quantifiable evidence to justify this statement, qualitatively the additional information is very useful to the operator as noted in Response to RAI 7.10(i).

### **RAI-7.11**

The regulations in 10 CFR 50.34(b)(2) require that the SAR contain a description and analysis of the SSCs of the facility, with emphasis upon performance requirements; the bases, with technical justification therefor, upon which such requirements have been established; and the evaluations required to show that safety functions will be accomplished. The description shall be sufficient to permit understanding of the system designs and their relationship to safety evaluations. Items such as I&C systems shall be discussed so far as they are pertinent.

The guidance in NUREG-1537, Part 2, Section 7.4, states that, “[t]he scram system should be designed to annunciate the channel initiating the action, and to require a resetting to resume operation.” NUREG-1537, Part 2, Section 4, states that the guidance in ANSI/ANS 15.15-1978 is useful as general guidance for the design, implementation, and evaluation of I&C systems. The guidance in ANSI/ANS-15.15-1978, Clause 5.8, states that, “[e]ach channel shall indicate in a distinctive manner when it is in the tripped state,” and that “[o]nce tripped, the RSS [reactor safety system] shall remain in the tripped state at the system level and shall indicate the protective instrument subsystem initiating the shutdown until deliberate action is taken by the reactor operator.”

During the Audit, the NRC staff viewed the new indicator and alarm panel, the PCS display, and the DCS display (P22, C10, and C13, respectively, in updated Figures 7-9 and 7-10 in UML's supplemental information dated April 10, 2019), which indicate the cause of a UMLRR alarm. As described in Chapter 7 of the SAR, the RSS channels are designed with 1/N logic; any one of N signal inputs to either logic unit will cause the trip actuator amplifiers to trip and initiate a reactor scram. During the Audit, the NRC staff reviewed the NMP-1000 user manual and observed that the NMP-1000 modules have a trip reset function on the main menu. However, it is not entirely clear how operators can distinguish which channel causes a trip, or if all channels need to be reset following a trip.

Describe the information available to the operators to distinguish the channel that caused the trip and the actual cause of the trip. Additionally, explain if all channels need to be individually reset or just the channel that tripped. Alternatively, discuss why no additional information is required.

## **Response to RAI 7.11**

The front face of each NMP1000 panel has red LED indicators for the various trips (high power alarm, high power scram, high voltage loss). These are described in section 2.3 of NMP1000 user manual. The previous version of NMP1000 (currently in use at the UMLRR) also has these features. As part of the checkout procedure (currently and for the new NMP1000), the operator verifies the indicator operation. If the trip/scram occurs on one channel then only that channel needs to be reset. The master scram relays (draft SAR 7.4.3.1) would also need to be reset.

## **RAI-7.12**

The regulations in 10 CFR 50.34(a)(7) and 10 CFR 50.34(b)(6)(ii) require that the SAR include “[a] description of the quality assurance program to be applied to the design, fabrication, construction, and testing of the SSCs of the facility,” and “[m]anagerial and administrative controls to be used to assure safe operation.”

The guidance in ANSI/ANS-15.8-1995 (endorsed by NRC Regulatory Guide 2.5), Clause 2.3.3, states that, “[t]he need for or the use of qualification tests shall be defined in a formal test plan that shall include appropriate acceptance criteria and shall demonstrate the adequacy of performance under conditions that simulate the most adverse design conditions. Test results shall be documented and evaluated by the responsible design organization to assure that test requirements have been met.”

The guidance in NUREG-1537, Part 1, Subsection 7.2.1, recommends that, “[a]ll systems and components of the I&C systems should be designed, constructed, and tested to quality standards commensurate with the safety importance of the functions to be performed.” The design acceptance criteria in NUREG-1537, Part 2, Section 7.4, states that, “[t]he design reasonably ensures that the design bases can be achieved, [and] the system will be built of high-quality components.”

During the Audit, UML staff indicated that they performed tests of the NMP-1000 upon receipt; however, a test plan was not developed, and test results were not recorded. UML stated that a test plan and documented test results (i.e., a site acceptance test) will be developed.

Provide the following, or discuss why no additional information is required:

- a. Describe how the quality of the components and modules of the I&C system upgrades (e.g., NMP-1000 and PPM) was verified to be commensurate with its safety importance. Additionally, describe how the QA program at the UMLRR provides controls over the design, fabrication, installation, and modification of the RPS to the extent that these impact UMLRR safety-related items.

## **Response to RAI 7.12a**

The quality processes employed by the manufacturers is noted in the responses to RAI 7.5a and 7.5b. The UMLRR does not have a QA program commensurate with 10CFR 50 Appendix B. However, portions QA management are applied throughout the procurement and installation pre-testing and post-testing procedures. For example, the manufacturer’s documentation is checked to verify the instrument will measure the neutron flux levels commensurate with the



present instruments. Other items such as alarm and scram outputs, and isolated remote signal outputs are checked for compatibility with existing instrumentation (e.g., chart recorders). For the NMP1000 instruments, this was a simple process as the manufacturer had indicated at the time of procurement in 2012 that the new units were a one-for-one like replacement for the existing NMP1000.

The TFS PPM used a procurement document that was used for comparison purposes. The procurement document provides the detailed specifications for the instrument that includes: generic and detailed requirements; the parameters monitored by the instrument; description of output displays and the range of the parameter displayed; the number and type of remote output signals; number and type of trip outputs; specification on instrument accuracy and response times; a detailed operations manual; and spare parts to be provided.

Pre-installation test procedures, both by the manufacturer and UMLRR are employed (please see responses to RAI 7.5 and 7.6). Post-installation verifications of operability are met using surveillance and pre-critical check procedures as revised for the new instruments.

- b. Describe the site acceptance testing (or other applicable V&V testing) that was performed for the NMP-1000 modules and how this testing validates that the NMP-1000s will meet the quality and design requirements for fulfilling its intended safety function as documented in Section 7.2 of the UMLRR SAR.
- c. Describe the site acceptance testing (or other applicable V&V testing) that was performed for the Thermo Scientific PPM and how this testing validates that the PPM will meet the quality and design requirements for fulfilling its intended safety function as documented in Section 7.2 of the UMLRR SAR.

### **Response to RAI 7.12b&c**

Please see response to RAI 7.6.

### **RAI-7.13**

The regulations in 10 CFR 50.34(b)(2) require that the SAR contain a description and analysis of the SSCs of the facility, with emphasis upon performance requirements; the bases, with technical justification therefor, upon which such requirements have been established; and the evaluations required to show that safety functions will be accomplished. The description shall be sufficient to permit understanding of the system designs and their relationship to safety evaluations. Items such as I&C systems shall be discussed so far as they are pertinent.

During the Audit, the NRC staff reviewed "T9S900D980-FME Rev A NMP-1000 Failure Modes Effects Analysis" (document No. 11 listed in RAI-7.4.a above). The NRC staff noted that Subsection 4.2.1.2 of the analysis documented that unused code was detected and subsequently removed from the NMP-1000 software. However, it is not clear if unused code was removed from the channels that are proposed to be used at the UMLRR. Additionally, the NRC staff reviewed the "20130207001-RPT, Revision 2, NetBurner-MOD54415 Module Validation Summary Report" (document No. 12 listed in RAI-7.4.a above) and noted that the code review checklist documents many instances of additions and removal of software code.

These changes include “bug” fixes, added NMP-1000 functionality, and removal of unused code.

- a. Verify and document that the unused code cited in the Failure Modes Effects Analysis was removed from subsequent NMP-1000 units, specifically, those sold to UML for installation as UMLRR equipment. Alternatively, justify why no additional information is required.

### **Response to RAI 7.13a**

In an electronic communication dated 07/14/17, a representative of GA confirmed the unused code was removed from all product releases, including the NMP1000 modules procured by UMLRR.

- b. Verify and document that the modifications to the software code detailed in the NetBurner-MOD54415 Module Validation Summary Report were also completed for NMP-1000 units sold to UML for installation as UMLRR equipment. Alternatively, justify why no additional information is required.

### **Response to RAI 7.13b**

An electronic communication dated 06/20/17, a representative of GA confirmed the UMLRR NMP1000 modules are identical to the INL NMP1000 modules detailed in the applicable GA documentation (RAI response 7.4a).

### **RAI-7.14**

The guidance in Section 7.4 of NUREG-1537, Part 2, recommends that TSs, including surveillance tests and intervals, should be based on discussions and analyses of required safety functions in the SAR and that the surveillance tests and intervals give confidence that the equipment will reliably perform its safety function. Additionally, ANSI/ANS-15.15-1978 recommends the system design include capability for periodic checks, tests and calibrations. ANSI/ANS-15.15-1978 also recommends that, if on-line periodic testing is necessary, such testing should not reduce the capability of the system to perform its safety function.

Provide the following, or justify why no additional information is required:

- a. The proposed UMLRR TSs submitted March 5, 2019, include the following:
  - TS 4.1(7) states, “[t]he linear and logarithmic power channels signals shall be checked against a heat balance annually”;
  - TS 4.2.3(3) states, “[a] channel calibration of the reactor power level channels (Linear and Log-N), and the period channel shall be made annually”;  
and
  - TS 4.2.3(4) states, “[t]hermal power level shall be verified annually.”

However, the purpose of, and difference between, proposed TSs 4.1(7), 4.2.3(3), and 4.2.3(4) is not clear to the NRC staff. Additionally, it is not clear to the NRC staff how proposed TSs 4.1(7), 4.2.3(3), and 4.2.3(4) would be applied for the proposed flux monitoring channels. Explain the purpose of and difference between these surveillance

requirements, including specific information regarding any changes to the calibration and verification procedures that apply to the proposed NMP-1000 modules and the proposed Thermo Scientific PPM. Additionally, if necessary, propose revised TSs.

### **Response to RAI 7.14a**

A channel calibration as defined in the proposed TS as “*an adjustment of the channel such that its output corresponds with acceptable accuracy to known values of the parameter which the channel measures. Calibration shall encompass the entire channel, including equipment actuation, alarm, or trip and shall be deemed to include a channel test.*” The channel calibration in draft TS 4.2.3(3) satisfies the ANSI/ANS 15.1 4.2(5)(b) requirement and applies to both the GA NMP-1000 modules and the TFS PPM. The thermal power verification in draft TS 4.2.3(4) satisfies the ANSI/ANS 15.1 4.2(8) requirement. Thermal power verification assures the reactor is not being operated in excess of the license limit when the power measuring channels measure 100% of full power. Draft TS 4.1(7) is an advertent redundancy that satisfies no corresponding ANSI/ANS 15.1 4.1 requirement and shall be removed in a future final version of TS to be submitted prior to relicensing. Both calibration and thermal power verification are performed for the existing UMLRR power measuring channels. The draft TS and proposed revision will have no effect on the calibration and verification procedures drafted for the NMP1000 modules and the TFS PPM.

- b. SAR Section 7.6.2.1, states that each HMI employs a failsafe “watchdog” timer that activates trip relays in the scram circuit. Table 3.2.3-1 of proposed TS 3.2.3 (in the proposed TSs submitted March 5, 2019), which stipulates the minimum number of reactor protection system scrams that shall be operable to ensure that the SL is not exceeded, includes LCO TSs for two watchdog timer scrams, item 9, “Process Controls Display Watch Dog Timer,” and item 10, “Drives Controls Display Watch Dog Timer.” Proposed TS 4.2.3(7) would require surveillances of several different scrams, including the watchdog timer scrams. However, the functionality of these timer scrams, and the bases of the LCO and surveillance TSs related to these scrams, is not clear to the NRC staff.
  - i. Explain in detail how the watchdog timer activates the trip relays in the scram circuit. Clarify or update information in the SAR, if needed.

### **Response to RAI 7.14b(i)**

In the OPTO22 Control program a Watchdog timer can be set so that an I/O unit can monitor communications activity from another device for a specified time interval. If no communication is received at the specified interval, the unit assumes a Watchdog state. The selected outputs for the I/O unit will then immediately go to a specified value as configured in the program. For the UMLRR HMI displays, a loss of communication will cause the Watchdog to de-energize and open the Watchdog output relay in the scram circuit (draft SAR 7.4.3.1) and initiate the scram.

- ii. Explain how the TS-required surveillance associated with the LCO TSs for the watchdog timer scrams is performed to assure their operability. Include a justification of the annual interval in TS 4.2.3 for verifying operability.

**Response to RAI 7.14b(ii)**

The watchdog timer scrams are currently tested using the approved UMLRR surveillance procedure SP-15 *Scram Functions Test*. The test is performed by opening the I/O chassis and disconnecting the communication cable for each individual HMI test. The HMI are not considered safety-related items (please see Preamble for Response to RAI 7.2). The annual test interval is consistent with ANSI/ANS 15.1 4.2(9). More frequent testing would create unnecessary wear on the communication cables.

- iii. The proposed LCO TSs for the watchdog timer scrams (submitted March 5, 2019), specify that the function of the scrams is a “[s]cram for communication loss >10 second.” However, the prior version of the proposed license renewal TSs originally submitted with the SAR dated October 20, 2015, specified that these scrams would be required to occur for a “communication loss >1 second.” Provide a safety basis justification for changing from 1 to 10 seconds. Additionally, if necessary, propose revised TSs.

**Response to RAI 7.14b(iii)**

The 10 second interval provides an adequate response time for a failure of either the PCS or DCS HMI. For the PCS HMI, the reactor protection channels specified in TS 3.2.5 operate independently of the HMI and include independent displays as described in the draft SAR 7.4.1 (as revised for the TFS PPM) and 7.4.2. For the DCS HMI, TS 3.2.2(1) states the maximum reactivity insertion rate by the most reactive control blade and the regulating rod simultaneously shall not exceed 0.05%  $\Delta k/k$  per second. Should a communication loss occur during a withdrawal of the most reactive control blade and the regulating rod simultaneously by the reactor operator, and the operator fails to respond, the maximum reactivity insertion that could theoretically occur would be 0.5%  $\Delta k/k$ . In reality, the maximum differential reactivity worth occurs at a single point near the mid-point (i.e., height) of the control blade/rod and then continually decreases at points above and below, resulting in a lower reactivity insertion value. The conservatively estimated 0.5%  $\Delta k/k$  value is less than the 0.64%  $\Delta k/k$  value used in the accident analyses provided in draft SAR 13.2.2 for a step reactivity addition. The analysis for a ramp insertion uses a more conservative reactivity insertion value 0.07%  $\Delta k/k$  per second and assumes the maximum differential worth is constant for the insertion. The analyses in SAR 13.2.2 show that neither the step or ramp scenarios reaches the onset of nucleate boiling which occurs at a temperature far below the Safety Limit value.

**RAI-7.15**

The regulations in 10 CFR 50.34(b)(2) require that the SAR contain a description and analysis of the SSCs of the facility, with emphasis upon performance requirements; the bases, with technical justification therefor, upon which such requirements have been established; and the evaluations required to show that safety functions will be accomplished. The description shall be sufficient to permit understanding of the system designs and their relationship to safety evaluations. Items such as I&C systems shall be discussed so far as they are pertinent.

The guidance in NUREG-1537, Part 2, Section 4, states that ANSI/ANS-15.15-1978 is useful as general guidance for the design, implementation, and evaluation of I&C systems. Clause 5.6 of ANSI/ANS-15.15-1978 states that, “[t]he RSS shall include physical features that assure that the proper setpoints are automatically made active or include features that facilitate administrative controls to verify the proper setpoints, or both, when the operating mode of the reactor is changed.”

During the Audit, the NRC staff observed that the proposed NMP-1000 Modules have a GA ID and generic password preinstalled for GA use. However, it is not apparent to the NRC staff whether this generic password is removed to limit unauthorized access to the channels once received at UML. Also, it is not evident to the NRC staff that UML has a process to control passwords once the channels are installed for use in the UMLRR (e.g., changing passwords when individuals leave the UMLRR staff or their access privileges change).

Verify that, once the NMP-1000 modules are delivered to UML, the GA ID and password, which is divulged in “cleartext” within the core module validation report (item No. 12 listed in RAI-7.4.a), will be removed or changed in the equipment prior to its use in the UMLRR. If the GA ID and generic password will not be removed or changed for equipment to be installed for use, explain why not. Additionally, discuss the process UML will use to remove access to NMP-1000 modules when individuals with prior authorized access (i.e., user ID and password) should no longer be authorized access, or explain why this process is not necessary. Alternatively, discuss why no additional information is required.

### **Response to RAI 7.15**

In an electronic communication dated July 17, 2019, a representative of GA confirmed that the user ID and password are associated with GA TRIGA console software and does not apply to the NMP1000. The UMLRR does not have a GA TRIGA console.

### **RAI-7.16**

The guidance in NUREG-1537, Part 1, Section 7.4, states that the information in the SAR should include “RPS scram time as established in the accident analysis, and any other requirements to ensure operability.”

During the Audit, the NRC staff reviewed the response time constants in Section 1.2, “Specifications,” in the “NMP-1000 Multi-Range Linear Module User Manual,” (item No. 14 listed in RAI-7.4.a above). The NRC staff noted that the response time values in the manual appear to be inconsistent with those in the NMP-1000 module specifications provided in SAR Table 7.2 and in the procedure for Test 2.29, “EMRT.STP.01, Electrometer - Response Time - Rev A,” in the Ethernet Core Module Validation Summary Report (item No. 12 listed in RAI-7.4.a above).

Proposed TS 3.2.1(2) stipulates that the scram time must be less than 1 second from a fully withdrawn control blade position to 80 percent inserted. The 1 second time includes the instrument delay time, as well as the time for the blade to physically drop by gravity to 80 percent inserted. However, given the apparent difference between the response times listed in these documents, it is not clear to the NRC staff how proposed TS 3.2.1(2) would be met, or whether the assumptions of the UMLRR accident analyses (i.e., reactivity transient analyses) are appropriate.

Provide the following, or justify why no additional information is required:

- a. Explain why the response times in the user manual (some of which are in units of seconds) appear to be different from those in the SAR and acceptance tests, which are in units of milliseconds. Alternatively, clarify that the response times in the user manual are the same as those in the SAR and acceptance tests, and provide a supporting reference to the user manual.

### **Response to RAI 7.16a**

The data presented in the draft SAR Table 7-2 for the NMP1000 came from the GA User Manual document T3401000-1UM Revision Draft X2 dated September 2013. This document was superseded by document T3401000-1UM Revision B dated June 2015. We were unaware of this revision at the time the draft SAR was submitted. The UMLRR has asked GA to confirm the Revision B values. If confirmed, the values in SAR Table 7-2 will be updated for the Final SAR.

- b. Verify that the response times listed in the SAR and acceptance tests will be used as the acceptance criteria for UML's acceptance testing of the NMP-1000 channels. Additionally, verify that the system requirements for the RPS (such as required scram times for both slow and fast scrams) are clearly and correctly identified and are consistent with the assumptions and system requirements in the accident analyses and TSs (SAR Chapters 13 and 14, as supplemented).

### **Response to RAI 7.16b**

For the UMLRR core, the neutron population associated with a critical configuration typically occurs in the 100W range as measured on the multi-range linear power channels (NMP1000). This corresponds to the 1E-7 mA range, which corresponds to a response time constant of 2 msec (NMP1000 User Manual Rev. B). For the range 1E-3 mA to 1E-6 mA, the NMP1000 response time constant is stated as 1 msec in both versions of the user manual. For the UMLRR this range equates to power levels of 1MW to 1kW. The UMLRR transient analyses for overpower scrams for natural convection mode ( $\leq 100\text{kW}$ ) and forced convection mode ( $\leq 1\text{MW}$ ) assume a conservative instrument delay time of 210 msec (SAR 13.2.2). The delay time is the interval between when the LSSS power level trip occurs and when the blades detach from the magnets and begin to drop into the core. The actual delay time has been measured as 185 msec (SAR 4.5.5). The delay time includes the control blade magnet decay time and the master scram relay coil decay time (SAR 7.4.3.1). Of these, the scram relay coil decay time accounts for most of 185 msec delay. The power measuring channel response time of 1 msec (for either the 100kW natural convection mode or 1MW forced convection mode) also provides an additional but insignificant delay in addition to the delay time. The 210 msec value used in the safety analyses includes an additional 25 msec for a margin of conservativeness. As a result, the NMP1000 response time at the LSSS power levels has no measurable effect on the delay time used in the accident analyses. The electronic scram bypasses the relays and produces a significantly shorter delay time of approximately 5 msec (SAR 7.4.3.2). However, for a greater margin of conservativeness the safety analyses, and subsequently the TS LSSS and LCOs, are based on the very conservative 210 msec value.

As part of the UMLRR acceptance test for the NMP1000 units and the TFS PPM, the delay time associated with each channel scram will be measured to verify it is within the 210 msec value used in the accident analyses. The control blade scram time also will be measured for each power measuring channel scram to verify it is within 1 second (TS 3.2.1(2)).

### **RAI-15.1**

The Nuclear Energy Innovation and Modernization Act (NEIMA) was signed into law on January 14, 2019. This law, among other things, established a criterion in Section 104(c) of the Atomic Energy Act of 1954, as amended (AEA), for the NRC to use to determine whether a utilization facility is licensed as a commercial or industrial facility (Class 103 license) or a research and development facility (Class 104(c) license).

Section 106 of NEIMA, "Encouraging Private Investment in Research and Test Reactors," amends the AEA by adding the following text to the end of Section 104(c):

The Commission is authorized to issue licenses under this section for utilization facilities useful in the conduct of research and development activities of the types specified in section 31 in which the licensee sells research and testing services and energy to others, subject to the condition that ***the licensee shall recover not more than 75 percent of the annual costs to the licensee of owning and operating the facility*** through sales of nonenergy services, energy, or both, other than research and development or education and training, ***of which not more than 50 percent may be through sales of energy.***

This criterion is in addition to, and different than, the criterion in 10 CFR 50.22, "Class 103 licenses; for commercial and industrial facilities," which states:

A class 103 license will be issued, to an applicant who qualifies, for any one or more of the following: To transfer or receive in interstate commerce, manufacture, produce, transfer, acquire, possess, or use a production or utilization facility for industrial or commercial purposes; *Provided, however,* That in the case of a production or utilization facility which is useful in the conduct of research and development activities of the types specified in section 31 of the Act, such facility is deemed to be for industrial or commercial purposes if the facility is to be used so that more than ***50 percent of the annual cost of owning and operating the facility is devoted to*** the production of materials, products, or energy for sale or commercial distribution, or to the sale of services, other than research and development or education or training.

(Note: Bold italics used for emphasis.)

The SAR, as supplemented, does not appear to specifically address the criterion in NEIMA regarding the percentage of the annual costs to the licensee of owning and operating the facility that is recovered through sales of nonenergy services, energy, or both, other than research and development or education and training.

Provide a statement identifying whether the percentage of the annual costs of owning and operating the facility recovered through sales of nonenergy services, energy, or both, other than research and development or education and training, is 75 percent or less, and whether the percentage of the annual costs of owning and operating the facility recovered from sales of energy is 50 percent or less.

### **Response to RAI 15.1**

The annual costs of owning and operating the UMLRR recovered through sales of non-energy services, energy, or both, other than research and development or education and training, is 75 percent or less, and the percentage of the annual costs of owning and operating the facility recovered from sales of energy is 50 percent or less.



Appendix A

RAI Response 7.1B

Scram Circuit Schematic

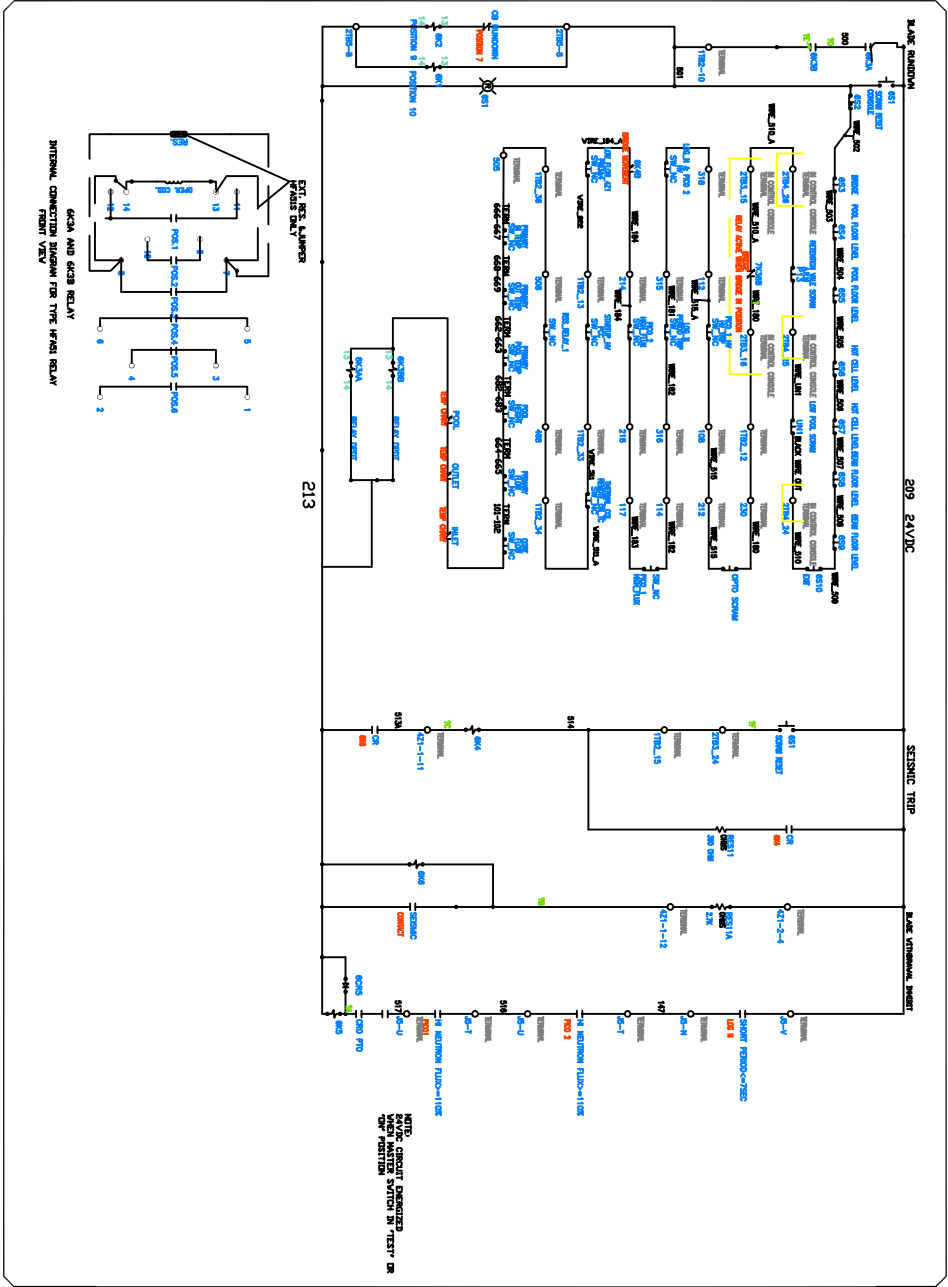

NO.	DESCRIPTION	DATE	BY	CHKD.
1	DESIGN	11/11/11	...	...
2	...	...	...	...
3	...	...	...	...
4	...	...	...	...
5	...	...	...	...
6	...	...	...	...
7	...	...	...	...
8	...	...	...	...
9	...	...	...	...
10	...	...	...	...
11	...	...	...	...
12	...	...	...	...
13	...	...	...	...
14	...	...	...	...
15	...	...	...	...
16	...	...	...	...
17	...	...	...	...
18	...	...	...	...
19	...	...	...	...
20	...	...	...	...
21	...	...	...	...
22	...	...	...	...
23	...	...	...	...
24	...	...	...	...
25	...	...	...	...
26	...	...	...	...
27	...	...	...	...
28	...	...	...	...
29	...	...	...	...
30	...	...	...	...
31	...	...	...	...
32	...	...	...	...
33	...	...	...	...
34	...	...	...	...
35	...	...	...	...
36	...	...	...	...
37	...	...	...	...
38	...	...	...	...
39	...	...	...	...
40	...	...	...	...
41	...	...	...	...
42	...	...	...	...
43	...	...	...	...
44	...	...	...	...
45	...	...	...	...
46	...	...	...	...
47	...	...	...	...
48	...	...	...	...
49	...	...	...	...
50	...	...	...	...
51	...	...	...	...
52	...	...	...	...
53	...	...	...	...
54	...	...	...	...
55	...	...	...	...
56	...	...	...	...
57	...	...	...	...
58	...	...	...	...
59	...	...	...	...
60	...	...	...	...
61	...	...	...	...
62	...	...	...	...
63	...	...	...	...
64	...	...	...	...
65	...	...	...	...
66	...	...	...	...
67	...	...	...	...
68	...	...	...	...
69	...	...	...	...
70	...	...	...	...
71	...	...	...	...
72	...	...	...	...
73	...	...	...	...
74	...	...	...	...
75	...	...	...	...
76	...	...	...	...
77	...	...	...	...
78	...	...	...	...
79	...	...	...	...
80	...	...	...	...
81	...	...	...	...
82	...	...	...	...
83	...	...	...	...
84	...	...	...	...
85	...	...	...	...
86	...	...	...	...
87	...	...	...	...
88	...	...	...	...
89	...	...	...	...
90	...	...	...	...
91	...	...	...	...
92	...	...	...	...
93	...	...	...	...
94	...	...	...	...
95	...	...	...	...
96	...	...	...	...
97	...	...	...	...
98	...	...	...	...
99	...	...	...	...
100	...	...	...	...

Autodesk

Appendix B

RAI Response 7.3b

50.59 Reviews Related to I&C Upgrades

APPROVED BY RS5C  
9/11/97

## INSTRUMENTATION UPGRADE FOR UMLRR

### DESCRIPTION OF CHANGES:

#### NUCLEAR INSTRUMENTATION:

Replace existing 1950's vacuum tube neutron instruments provided by GE with original reactor with modern solid state instruments provided by General Atomics/Sorrento Electronics for more reliable operation and compatibility with current parts suppliers. The upgraded instruments will also be capable of computer data logging and information display.

#### RADIATION MONITORING

Replace obsolete Tracerlab radiation monitoring system, including detectors and readout units, with modern microcomputer-based instruments from Nuclear Research Corporation. The replacement instruments will be more flexible and adaptable, as well as provide digital data logging and display.

### SAFETY ANALYSIS FOR PROPOSED NEUTRON MONITORING INSTRUMENT CHANGES PER 10CFR 50.59

Q. a. Is there a change to the facility or procedures as described in the safety analysis report?

A. This is a change to the facility since the replacement instruments are different in appearance and signal processing detail. The replacement instruments have been purchased to the same performance specifications as original instruments. A detailed comparison of the existing current instruments and the replacements is shown in Tables 1 and 2. The function and performance of the instrumentation is not changed by this replacement. The reliability will be increased by replacement of vacuum tubes with solid state devices. The narrative description of the neutron monitoring instruments in the FSAR is unchanged by the replacement. Drawing descriptions which use specific General Electric instrument identifications will need to be changed to reflect the up-grade.

There is an operational difference in using the new picoammeters. The linear power meters can be set to autorange to the top of a selected

range (100kw or 1 Mw). Functionally and practically, this is the same as the manual uprange in present use. The circuit response time is about the same as operator manual response. The rate of power increase is practically and procedurally set by a reactor period of about 60 seconds whether the instruments are manually or automatically ranged upscale.

Further, specific procedures will require changes to accomodate the new instruments.

Q. b. Is a test or experiment to be conducted that is not described in the safety analysis report?

A. No test or experiment will be conducted differently from the SAR description as a result of the proposed change.

Q. c. Is there a change to the University of Massachusetts Lowell Research Reactor Technical Specifications and/or Safety Analysis Report?

A.. No change to Technical Specifications is needed for the proposed change.

Nomenclature descriptions in the Updated Final Safety Analysis Report will need to be changed to accomodate the change proposed here, but no functional or narrative descriptions will be changed.

Q. d. Is there an unreviewed safety question per 10CFR50.59?

A. No. There is no change to any safety parameter, accident scenario, accident consequence, probability of occurrence, or different type of accident as a result of the instrument changes proposed.

### UFSAR Drawing Description Changes

Startup Channel	<u>GE Description</u>	<u>present description</u>
Fig. 4.15	15PS7 power supply	Tennelec TC940
	10AR3 scaler	Tennelec TC555A
	10AR2 log CR amp	Tennelec TC527
	10AR1 preamp	Tennelec TC133
	10AR1A linear amp	Tennelec TC213
	recorder	EsterlineAngus

Automatic Power Level Control		<u>future unit</u>
Fig. 4.16	12AR1 micromicroammeter	GA NMP-1000(FC)
	9Z1 circuitry	circuitry modified for NMP-1000(FC)

Intermediate Channel		
Fig. 4.17	11RR1 log n recorder	Esterline Angus
	11RR2 period recorder	Esterline Angus

11AR1 log n period amp      GA NLI-1000

Flux Level Safety Channel

Fig. 4.18      12AR1 micromicroammeter      GA NMP-1000  
                  12AR2 micromicroammeter      GA NMP-1000  
                  12AR1 flux recorder      Esterline Angus

Appendix 10

Tracerlab

Nuclear Research Corp

TA-61

GP-100, GP-100C

TA-62

IP-100

TA-64

NP-100

Changes to the following procedures will be necessitated by the change in instruments:

- CP-1 Calibration of Log n Neutron Monitor
- CP-2 Calibration of Picoammeter Neutron Monitor
- RO-9 Reactor and Control System Checkout Procedures
- RO-5 Routine Startup
- SP-1 Calibration of Radiation Monitoring System

## Specifications: Linear Power Channel

<u>SPECIFICATION</u>	<u>CURRENT PICO</u>	<u>NMP - 1000</u>
Current	$10^{-12}$ to $10^{-3}$ amps Covering seven decade ranges	$10^{-11}$ to $10^{-4}$ A or $10^{-10}$ to $10^{-3}$ A. Covering seven decade ranges
Linearity	$\pm 2\%$ at full scale $10^{-12}$ - $10^{-11}$ $\pm 3 > 10^{-11}$ range	$\pm 1\%$ at full scale upper 5 ranges $\pm 2.5\%$ lower 2 ranges
Temp. Coeff.	$\pm 0.08\%$ per $^{\circ}\text{C}$ over $0^{\circ}$ - $55^{\circ}$	$\pm 0.15\%$ per $^{\circ}\text{C}$ over $10^{\circ}$ - $55^{\circ}$
Response time	$<2\text{msec}$ $10^{-3}$ to $10^{-9}$ A, $<10\text{msec}$ $10^{-10}$ , $<100\text{msec}$ $10^{-11}$ , $<1000\text{msec}$ , $10^{-12}$	$1\text{msec}$ $10^{-5}$ to $10^{-3}$ A, $10\text{msec}$ $10^{-9}$ to $10^{-8}$ A $100\text{msec}$ $10^{-11}$ to $10^{-9}$ A
Power	115 VAC $\pm 10\%$ , 50/60Hz, 60W	117 VAC $\pm 10\%$ , 50/60 Hz at 1.0A
Calibration source	none	Internal calibration checks for low range and high range power

### General Specifications on Performance of Both Instruments:

- Upscale high level trip to change from 12 vdc to 0 vdc when tripped to electronic reactor trip logic circuit. Variable settings with typical trip at 120% of selected range.
- Upscale trip with open relay contacts when tripped, else close contacts to scram relay safety chain. Variable settings with typical trip at 120% of selected range.
- Upscale trip with open relay contact when tripped, else close contact to provide control rod withdrawal inhibit and annunciation of high power level. Typical setting at 110% selected range.
- Downscale trip with open relay contact when tripped, else close contact to inhibit control blade withdrawal on downscale indication. Typical trip setting from 5% to 20% of selected range. Included is a provision to bypass rod withdrawal inhibit on the most sensitive range.
- High voltage drop of 100 vdc from set point results in open relay contacts of the safety chain trip.
- Instruments provide indication of (linear) power continuously to remote operator console and 0-10V chart recorder. Trip status for each trip function indicated by lights on control panel in addition to the remote operator console.
- Loss of power to the instrument or instrument failure shall cause the safety-related trips to assume their tripped states and result in reactor scram and rod motion inhibit.

Specifications: Logarithmic Power and Reactor Period Channel

<u>SPECIFICATION</u>	<u>CURRENT LOG N</u>	<u>NLI - 1000</u>
Current	1E-10 to 1E-4 amps	1E-10 to 1E-3 amps
Linearity	± 2% at full scale period	± 3% at full scale period
Temp. Coeff.	± 0.15% per °C over 10° - 55°	± 0.15% per °C over 10° - 55°
Response time	< 100 μs For 1E-11 to 1E-5 A	< 100 μs
Power	115 VAC, 50/60Hz, 50W	117 VAC, 50/60 Hz
Range	-30 to 3 s. (period) 1E-5 to 100% (power)	-30 to 3 s. (period) 1E-5 to 100% (power)
Neutron Flux Range	3 nv to 3E11 nv	3 nv to 3E11 nv

General Specifications on Performance of Both Instruments:

- Upscale period trip to change from 12 vdc to 0 vdc when tripped to electronic reactor trip logic circuit. Variable settings with typical trip range from 10 to 3 seconds.
- Upscale trip with open relay contacts when tripped, else close contacts <sup>in</sup> to scram relay safety chain. Variable settings with typical trip range from 10 to 3 seconds.
- Upscale trip with open relay contact when tripped, else close contact to prevent automatic power control. Variable setting with typical trip range from 30 seconds to 10 seconds.
- Upscale trip with open relay contact when tripped, else close contact to prohibit control blade withdrawal on short reactor period and to energize short reactor period annunciation light on the scram panel. Typical setting range from 10 to 60 seconds.
- High voltage drop of 100 vdc from set point results in open relay contacts <sup>in</sup> of the safety chain <sup>relay</sup> trip.
- Instruments provide indication of logarithmic power and reactor period continuously to remote operator console. Trip status for each trip function indicated by lights on control panel in addition to the remote operator console.



## STEPS FOR NEW NUCLEAR INSTRUMENTS

1. DEVELOP DESCRIPTION OF CHANGE
2. WRITE INSTRUMENT IMPLEMENTATION PLAN
3. DESIGN INTERCONNECTIONS AND TEST PLAN
4. PERFORM SAFETY ANALYSIS AND 10CFR50.59 REVIEW  
PRESENT TO RSSC  
COURTESY INFO LETTER TO NRC
5. DRAFT PROCEDURES- NEW ROS, CPS, SPS  
PRESENT TO RSSC
6. INSTALL NEW INSTRUMENTS PER 2. AND 3. ABOVE; EXECUTE TEST PLAN
7. TRIAL USE OF PROCEDURES, DEBUG, GO FINAL
8. PLACE NEW INSTRUMENTS IN REGULAR SERVICE

## INSTRUMENTATION UPGRADE FOR UMLRR

### DESCRIPTION OF CHANGES:

#### RADIATION MONITORING

Replace obsolete Tracerlab radiation monitoring system, including detectors and readout units, with modern microcomputer-based instruments from Nuclear Research Corporation. The replacement instruments will be more flexible and adaptable, as well as provide digital computer interfaces for data logging and display.

This change will restore the original FSAR detection system. Two detectors [K, reactor bridge, and S, core exit] had been changed from ion chambers to wide-range GM detectors some time in the past. This replacement will implement the detector configuration described in the FSAR using up-to-date electronics.

#### SAFETY ANALYSIS FOR PROPOSED NEUTRON MONITORING INSTRUMENT CHANGES PER 10CFR 50.59

Q. a. Is there a change to the facility or procedures as described in the safety analysis report?

A. This is a change to the facility since the replacement instruments are different in appearance and signal processing detail. The replacement instruments have been purchased to the same performance specifications as original instruments. A detailed comparison of the existing current instruments and the replacements is shown in Tables 1 and 2. The function and performance of the instrumentation is not changed by this replacement. Descriptions which use specific instrument identifications will need to be changed to reflect the up-grade.

Further, specific procedures will require changes to accommodate the new instruments.

Q. b. Is a test or experiment to be conducted that is not described in the safety analysis report?

A. No test or experiment will be conducted differently from the SAR description as a result of the proposed change.

Q. c. Is there a change to the University of Massachusetts Lowell Research Reactor Technical Specifications and/or Safety Analysis Report?

A.. No change to Technical Specifications is needed for the proposed change.

Nomenclature descriptions in the Updated Final Safety Analysis Report will need to be changed to accomodate the change proposed here, but no functional or narrative descriptions will be changed.

Q. d. Is there an unreviewed safety question per 10CFR50.59?

A. No. There is no change to any safety parameter, accident scenario, accident consequence, probability of occurrence, or different type of accident as a result of the instrument changes proposed.

UFSAR Description Changes to Reflect New Instruments:

Chapter 7:

Constant Air Monitors . . . delete reference to Nuclear Measurements Corp. and Tracerlab

Chapter 10 . . . delete references to specific Tracerlab detectors.

Changes to the following procedures will be necessitated by the change in instruments:

SP-1 Calibration of Radiation Monitoring System  
RO-13 Radiation Monitoring Equipment Checkout

Table 1  
Radiation Monitoring Comparison

<u>parameter</u>	<u>existing(Tracerlab)</u>	<u>replacement(NRC)</u>
principle of operation	solid state analog ratemeter for GM pulses or ion chamber current	microprocessor-based digital signal processor time-to-count method

alarms & outputs	setpoints trigger solid state switches	setpoints trigger relay drivers
setpoint control	potentiometers	digital inputs
GM detectors	GM wide range	GM wide range 10microR-1E4R/hr
ion chambers		10microR-100R/hr
neutron detector	BF-3 tube in polyethylene	same
CAM	end window GM with local ratemeter driving meter relay units	end window GM in microprocessor system like all other detectors

Comments:

1. The relay tree for containment isolation (GRVS) remains unchanged.
2. Power loss results in safe failure state; loss triggers GRVS.
3. New system allows failure detection for such things as loss of flow in CAMs or loss of power or signal to a detector. This will be used for operator information and, where appropriate, direct GRVS actuation.

## 1. General Description

The NLI-1000 is a nuclear logarithmic power monitoring channel (Fig. 1-1). It is designed to measure seven decades of neutron flux using current measuring techniques. The instrument system consists of two separate items - a standard compensated ion chamber and a logarithmic current conditioning chassis. The NLI-1000 is designed to measure neutron flux from less than  $10^3$  to  $10^{10}$  nv, and provides adjustable bistable trips for local and remote alarms, isolated digital and analog outputs, and local power/period/high voltage meters. The signal conditioning instrumentation is enclosed in a flameproof steel enclosure with metallic conduit connectors.

Figure 1-2 presents a simplified block diagram of the NLI-1000. A detector (compensated or uncompensated ion chamber) is connected to the signal conditioning chassis via coax cables. Detector high voltage is provided by a high voltage power supply located in the NLI-1000 chassis. Detector compensation voltage is also provided by a power supply in the NLI-1000 chassis. The neutron signal (current) is routed to the NLI-1000 chassis via J2 on the rear of the NLI-1000 chassis.

When used with a compensated ion chamber, the NLI-1000 is capable of logarithmically measuring seven decades of neutron flux by utilizing a compensation voltage to cancel the signal contribution due to  $\gamma$  radiation. When used with an uncompensated ion chamber, the NLI-1000 is capable of logarithmically measuring four decades (or better) of neutron flux.

The logarithmic power signal (current) is monitored by a period circuit which generates an output proportional to the rate of change in reactor power at any given instant. This signal is a measure of the time (in seconds) it takes for the reactor power to change by a factor of "e" (2.718...).

The reactor power, high voltage and period are constantly monitored for excursions above or below preset limits. Relay and digital outputs are available for use as trips, and isolated and non-isolated analog outputs are available for local or remote monitoring.

Calibration, test and operational modes are controlled either by local or remote inputs as configured by the NLI-1000 front panel controls. Three calibration/trip test signals are available for use in testing channel operation. The NLI-1000 will automatically reset to **OPERATE** mode from any calibration/test mode after 50 seconds to prevent inadvertent reactor operation with the channel in calibrate or test modes.

## 2. Specifications

**Input Range:**

Current .....  $1 \times 10^{-10}$  to  $3 \times 10^{-3}$  Amperes

**Linearity (Log**

Conformity) .....  $\pm 3\%$  Full scale equivalent above  $\gamma$  compensation (temperature range of  $20^\circ$  to  $30^\circ$  C).

**Temperature**

Coefficient .....  $\pm 0.15\%$  per  $^\circ\text{C}$  (maximum) over the temperature range  $10^\circ$  to  $55^\circ\text{C}$ .

Calibration/Test ..... 2 fixed currents for calibration; 1 adjustable current for trip testing; HV trip test; period trip test. Test modes selected sequentially by front panel or remote control.

Response Time Constants ..  $< 5$  mSec.

**Outputs:**

Local Meter .....  $10^5$  to 100 Percent Power<sup>1</sup>  
0 to 1000 VDC  
-30 to +3 Second Period

Remote Meter - Isolated.. 0-10 V Full Scale, 0-1 mA Full Scale, 4-20 mA Full Scale (optional)

Recorder - Non Isolated... 0-0.1 V Full Scale, 0-1 V Full Scale

High Voltage ..... +300 to +800 VDC @ 2.6 Watts

Bistable Trips ..... 1 - High Voltage, 1 - High Power, 3 - Configurable Power (Increasing or Decreasing), 1 - Period (All are adjustable with two form C contacts and one logic level output per trip)

Power Requirements ..... 117 VAC  $\pm 10\%$ , 50/60 Hz @ 1.0 Amp

---

<sup>1</sup> Other scales available, such as  $10^5$  to 200%, etc.

### 3.3.2 Bistable Trips

Six bistable trips are available to alarm on low high voltage, high period, and four independently adjustable levels of output power. ~~Four relays are provided with two sets of normally open and normally closed contacts for customer use.~~ The relays are held energized in a fail-safe condition until the alarm de-energizes the coil. Each relay may be individually configured to drop out or stay active in test/calibrate modes. Refer to the relay board schematic for circuit details.

### 3.3.3 High Voltage Trip

U15:C on the motherboard buffers and monitors the 100:1 voltage divider output (3 to 8 volts DC) of the PRM HV101-2 high voltage power supply, representing 300 to 800 volts DC detector bias voltage. R142 (HV Trip Ref) on the trip board is set for the minimum desired detector operating voltage. If 700 VDC is the minimum desired operating voltage, R142 would be adjusted for 7.0 VDC at U25-6. With the HV power supply operating above 700 VDC, U25-6 will be more negative than U25-5 which will keep the output at pin 7 positive, thereby holding Q4 in conduction when the channel is in operate mode. With Q4 in conduction, RL1 will be energized. If the high voltage drops below the HV Trip Ref, the potential at U25-5 will be more negative than U25-6, which will cause the output at U25-7 to swing negative, turning off Q4. With Q4 turned off +15 VDC will be removed from the coil of RL1. Note that each trip relay may be configured to drop out when the channel is not in OPERATE mode by pulling the Arm line low, turning off Q5 (in the case of the high voltage trip). This removes the potential at the collector of Q4, dropping out the relay.

U26:D is normally turned on to +15 VDC by R144. When U25-7 swings negative, current passes through the phototransistor in U26:D causing D27 and R138 to bias the comparator U25:B into a latched state. The output of U25:B will remain low (keeping RL1 de-energized) until the HV Mon Out potential at U25-5 exceeds the HV Trip Ref setpoint at U25-6 and the trip TRIP RESET push button is pushed. This will turn off the photodiode in U26:D by pulling the Trip Rst line to ground, which turns off the phototransistor in U26:D, unlatching the comparator.

In a tripped condition, the low level output at U25-7 is twice inverted, providing a low level at U29-11, which turns on the photodiode in U26:B (enabling the HV Trip Logic Out lines) and turning on the high voltage trip LED (LED13). In a non tripped condition, the high level output of U25:B is twice inverted, turning off U26:B which will turn off the high voltage trip LED.

Note that de-energizing the trip relays by placing the channel in CALIBRATE or TEST mode will not actuate the individual trip LEDs.

### **3.3.4 Power Level Trips**

The NLI-1000 is equipped with four independent power level trips. Power Level TRIP 1 may be configured as an increasing or decreasing trip depending on the jumper configuration on JP1 and JP2. TRIP 2 is configured as an increasing trip, and TRIP3 and TRIP 4 may be configured to be increasing or decreasing trips. To configure TRIP 1 as a decreasing trip jumper JP1-1 to JP2-2 and JP1-2 to JP2-1. To configure TRIP 1 as an increasing trip jumper JP1-1 to JP1-2 and JP2-1 to JP2-2.

The power level trips operate in a similar manner to the HV Trip described in 3.5.2 except that the monitored signal is applied to the negative terminal of the comparator when the trip is configured as an increasing trip. As above, the monitored signal is applied to the positive comparator input when configured as a decreasing trip.

**Important:** Power Level TRIP 1 is equipped with a jumper which allows the channel to be placed in a "scram bypass" condition via the **PULSE INTERLOCK** switch when the channel is in local mode, or via the external pulse interlock (EXTPI) when in remote mode. If there is a jumper from pin 1 to pin 2 of JP3, the channel is configured to operate as described above. The jumper is not factory installed unless the customer requests that the NLI-1000 be so equipped.

### **3.3.5 Period Trip**

The period trip operates on an increasing signal as described above for power TRIP 2.



### 3.4 Outputs/Isolation Amplifier Board

#### 3.4.1 Bistable Trips/Isolated Digital Trip Logic

The bistable trips provide the user with two sets of normally open and normally closed contacts per trip relay. Choice of alarm state (open or close on alarm) is left to the customer. Power level TRIP 1 is hardware configurable for operation as an increasing or decreasing trip (see 3.5.3). Contacts are rated at 0.6 A at 125 VAC or 0.6 A at 110 VDC. An optically isolated logic output for external monitoring of the trip status with 5000 VDC isolation is provided for each bistable trip (U26:B, U26:A, U27:B, U27:A, U32:B, U32:A).

CONNECTS TO FAST TRIP CIRCUIT

#### 3.4.2 Isolated Outputs

The isolated analog outputs reside on a circuit board which plugs into the NLI-1000 mother board. Two isolated analog outputs are provided with options to drive remote meters and recorders in a variety of configurations. Standard outputs are available as 0 to 10 volts or 4-20 mA full scale, depending on if R905 and/or R915 are installed. Other output configurations are available from the factory.

WHICH PROVIDED?

Output isolation amplifier AR901 provides an output corresponding to the -30 to +3 second period signal. Isolation amplifier AR902 provides an output signal corresponding to 10<sup>-4</sup> to 100% power. The internal loop supply of each isolation amplifier galvanically isolates the input loop from the output terminals and provides 1500 V RMS transient protection. Signal conditioning is accomplished through a modulator which converts the input voltage into a proportional square wave that is passed through an isolation transformer and is demodulated and filtered to provide an output proportional to the input.

### 3.5 Power Supplies

AC line power is supplied to the NLI-1000 through a line power cord connected to the rear of the channel (the NLI-1000 requires 117 VAC, 50/60 Hz). S/F1 on the rear of the channel controls the input power to the NLI-1000 power supply. Two 1 amp fuses (S/F1 and F2) are connected to the "hot" AC line for overcurrent protection.

#### 3.5.1 Low Voltage Power Supplies

Input AC is applied to the primary windings of T1, which is a 24 VCT transformer. D1 through D4 rectify the output of T1, and provide 24 V unregulated power to the high voltage power supply and to the trip indication LEDs. The output of the bridge rectifier is also applied to the filter consisting of C1, C2, C3, R2 and R3, and is

SECTION I

DESCRIPTION

1.1 General

The General Electric Log N-Period Amplifier, Catalog Number 8NCO2, is designed for nuclear reactor neutron measurement and control in the intermediate range between startup and full power operation. The amplifier indicates the reactor power level, and the reactor period in seconds. It generates a period or a Log N trip signal and provides for control of external equipment when the input exceeds a pre-set rate of change or level.

The Log N-Period Amplifier may also be used as a log micromicroammeter for radiation monitoring, process monitoring, and dosimetry work.

When the Log N-Period Amplifier is used with a gamma-compensated ion chamber, the General Electric High Voltage Power Supply, Catalog Number 693C343G2, is recommended. This unit is a dual power supply with simultaneous positive and negative output voltages. More than one ion chamber may be supplied from each power supply.

1.1.1 Log N Amplifier and Meter

Operation of a nuclear reactor requires that the neutron flux (or fission rate) be known over a wide range. The Log N meter performs this function by measuring ionization current over seven decades of power level. Basically, it is a micromicroammeter utilizing an operational d-c amplifier with logarithmic feedback and fast response. The Log N meter indicates ionization current (power level) in AMPERES, RELATIVE POWER, or PERCENT POWER, depending on which optional meter is furnished.

1.1.2 Period Amplifier

Period is the interval in which power level is changing by a factor of 2.718. Since the power level may increase exponentially, it is important to be able to trip the nuclear reactor when the rate of power increase becomes too rapid. The Period Amplifier differentiates the voltage signal indicating the time derivative of the logarithm of the neutron flux. Period indication is by means of the PERIOD SECONDS meter.

1.2 Options

Several optional features can be furnished with the basic Log N-Period Amplifier. The type of system in which the instrument is to be utilized will determine these options.

The options are outlined in Sub-sections 1.2.1 through 1.2.7.

### 1.2.1 Log N Circuits

- a.  $10^{-11}$  to  $10^{-4}$  AMPERES seven-decade logarithmic scale
- b.  $10^{-7}$  to 1 RELATIVE POWER seven-decade logarithmic scale
- c.  $10^{-5}$  to 100 PERCENT POWER seven-decade logarithmic scale

### 1.2.2 Period Circuits

- a. -100 to infinity to +10 PERIOD SECONDS hyperbolic scale
- b. -30 to infinity to +3 PERIOD SECONDS hyperbolic scale
- c. Period circuit omitted

### 1.2.3 Meters

- a. General Electric DB-18 meter, 7.1 inch scale, 1% accuracy switch-board type meter
- b. General Electric DO-91 meter, 2.9 inch scale, 2% accuracy panel type meter
- c. Front-panel mounted
- d. External only
- e. Front-panel mounted and external

### 1.2.4 Trip Circuits

Up to three trip circuits can be provided. The trip circuits can be connected to provide trip functions on upscale or downscale input signals. One of the following selections for each trip circuit is available:

- a. Trip Circuit Number One
  1. Upscale trip on Log N with automatic reset
  2. Downscale trip on Log N with automatic reset
  3. Upscale trip on Period with automatic reset
  4. Downscale trip on Period with automatic reset
  5. Upscale trip on Log N with manual reset
  6. Downscale trip on Log N with manual reset
  7. Upscale trip on Period with manual reset
  8. Downscale trip on Period with manual reset

- b. Trip Circuit Number Two
  - 1. Upscale trip on Log N with automatic reset
  - 2. Downscale trip on Log N with automatic reset
  - 3. Upscale trip on Period with automatic reset
  - 4. Downscale trip on Period with automatic reset
- c. Trip Circuit Number Three
  - 1. Upscale trip on Log N with automatic reset
  - 2. Downscale trip on Log N with automatic reset
  - 3. Upscale trip on Period with automatic reset
  - 4. Downscale trip on Period with automatic reset

#### 1.2.5 Front Panel

- a. Standard 8-3/4 inch by 19 inch relay rack panel (flush mount)
- b. Power Plant Panel, 9-3/8 inches by 19 inches (semi-flush surface mount)

#### 1.2.6 Instrument Color

- a. Light grey
- b. The instrument can also be furnished in other colors if specified by the customer

#### 1.2.7 Ordering Information

Specification data sheets are provided at the back of this manual to assist in ordering the Log N-Period Amplifier. The appropriate boxes should be checked and the data sheet forwarded with the order for the instrument. The optional features required can be furnished with the instrument.

### 1.3 Construction

The Log N-Period Amplifier is a rugged industrial instrument designed for continuous service where high reliability is of importance to the user. It is constructed for either standard relay rack mounting or semi-flush mounting.

"Chimney" type construction is used in the Log N-Period Amplifier. This type of construction eliminates trapped warm air by vertical component board mounting. All components are exposed to the free flow of air, thus providing effective cooling.

Electronic components are mounted on the component boards by using teflon-insulated stand-off terminals. Construction details are shown in Figures 1-1 and 1-2.

#### 1.4 Specifications

##### 1.4.1 Log N Level

Range:	$10^{-10}$ to $10^{-4}$ amperes
Scale:	See Paragraph 1.2.1
Accuracy:	$10^{-11}$ to $10^{-10}$ Ratio of observed to true reading greater than 0.7 and less than 1.4 $10^{-5}$ to $10^{-4}$ $10^{-10}$ to $10^{-5}$ Ratio of observed to true reading greater than 0.85 and less than 1.175
Response Time:	Less than 100 microseconds for step change of $10^{-11}$ to $10^{-5}$ amperes
Trip Set Points:	Screwdriver locking adjust, front panel sub-plate, variable over entire Log N range

##### 1.4.2 Period

Range:	$-100$ to $\infty$ to $+10$ period seconds $-30$ to $\infty$ to $+3$ period seconds
Scale:	See Paragraph 1.2.2
Drift:	Less than $\pm 2\%$ at full scale period
Accuracy:	Reciprocal of observed period will be within $\pm 0.005$ of the reciprocal of the true period
Response Time:	Less than 10 seconds for step change from $\infty$ to full scale period
Trip Set Points:	Screw driver locking adjust, front panel sub-plate, variable over entire period range

##### 1.4.3 Meters

Front Panel:	See Paragraph 1.2.3
Remote:	See Paragraph 1.2.3

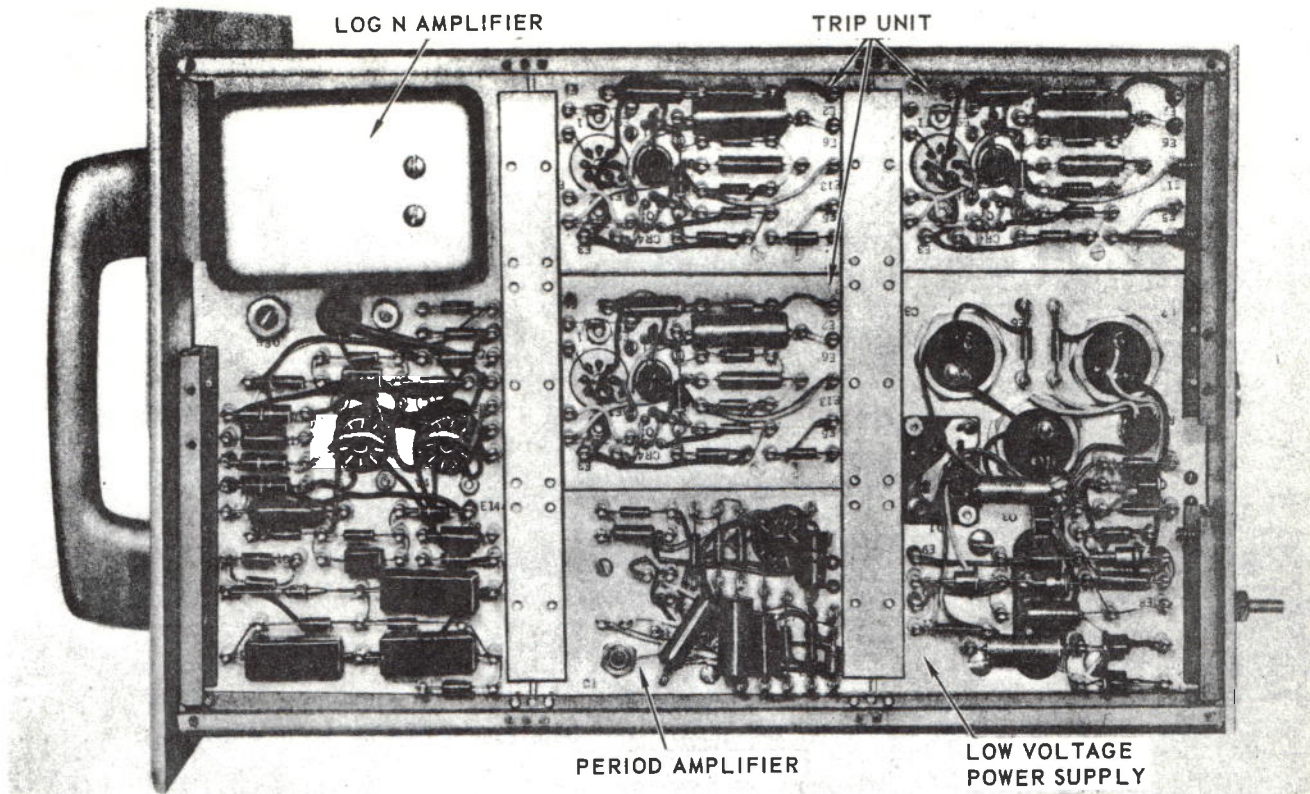

398-1

FIGURE 1-1 LOG N AND PERIOD AMPLIFIER, LEFT SIDE

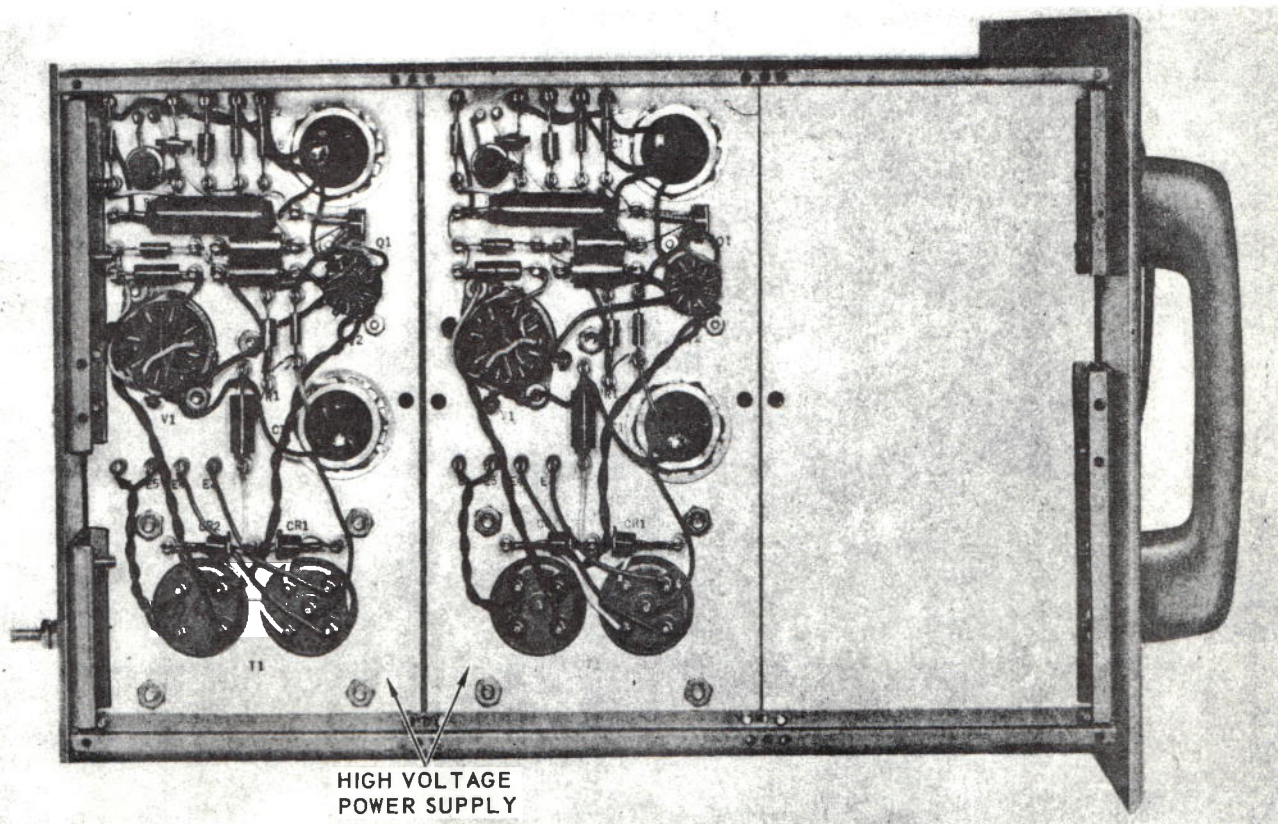

398-2

FIGURE 1-2 LOG N AND PERIOD AMPLIFIER, RIGHT SIDE

1.4.4 Outputs

Remote Meters: 0 to 1 ma d-c for both Log N and Period  
Remote Recorders: 0 to 1 ma d-c for both Log N and Period  
Trip: 12 volts d-c to 0 volts from each trip unit.  
Up to three sets of SPDT 2 ampere, 115-volt  
a-c relay contacts from each trip unit

1.4.5 Power Requirements: 115 volts a-c, 50/60 cps, 50 watts

1.4.6 Fuse: 2 ampere, mounted on front panel

1. SPECIFICATIONS

Input Range	10 <sup>-11</sup> to 10 <sup>-4</sup> A or 10 <sup>-10</sup> A to 10 <sup>-3</sup> A in seven one decade ranges. Self-bailing illuminated pushbutton or automatic range switching (manual or auto, operator selected). Provision for remote range switching.
Linearity	±1.0% of full scale upper 5 ranges; ±2.5% of full scale lower 2 ranges.
Temperature coefficient	±0.15%/°C maximum in the range of 10° to 55°C.
Calibration/test	Two fixed currents for calibration, one adjustable current for multi-range function test and trip testing. HV trip test, test modes selected sequentially by front panel control.
Response time constant	1 msec 10 <sup>-4</sup> to 10 <sup>-3</sup> A; 10 msec 10 <sup>-9</sup> to 10 <sup>-4</sup> A; 100 msec to 10 <sup>-11</sup> to 10 <sup>-9</sup> A.
Outputs	Remote meter: 0-10 V full scale Remote meter: 0-1 mA full scale Recorder: 0-0.1 V full scale Recorder: 0-1.0 V full scale Optional: 4-20 mA full scale High voltage: 300 to 800 V dc at 2.6 W Compensation: 0 to -150 V dc
Bistable trips	High voltage trip High power trip High power alarm
Power required	117 V ac ±10%, 50/60 Hz at 1.0 A

Adjustable with +5 V logic level and two form C contacts per trip } CONNECTED TO "FAST" TRIP.



from the Flux Controller to the 15 volt level required by the NMP-1000. Output BCD signals are buffered by U403 for use by the Flux Controller. The optional Flux Controller communicates via RS232C to external devices as required by the customer.

## 2.2. TRIP CIRCUITS

### 2.2.1. Bistable Trips

Three bistable trips are used to alarm on low high-voltage and two independently adjustable levels of output power. Three relays (K404, K405, and K406) are provided with two sets of normally open and normally closed contacts for customer use. The relays are held energized in a fail-safe condition until an alarm de-energizes the coil.

### 2.2.2. HV Trip

AR403 monitors the 100:1 voltage divided output of PS101 (3 to 8 volts) representing 300 to 800 volts DC detector bias voltage. R462 (HV TRIP SET) is set for a minimum desired operating voltage. If 700 VDC is the minimum detector operating voltage, R462 would be adjusted to provide 7 VDC at AR403-9. With the PS101 operating at above 700 VDC, AR403-9 will remain more negative than AR403-10 which will keep the output at pin 8 positive (+13 to +14.5), thereby holding Q408 in conduction which keeps K406 energized. If the high voltage drops below the nominal setting of 700 VDC, the potential at AR403-10 will be more negative than AR403-9 and the output of AR403-8 will swing negative turning off Q408. With Q408 not conducting, the +15 VDC will be removed from the coil of D406. U418D is normally turned on by R458 to +15 VDC and when AR403-8 goes negative, current passes through the phototransistor of U418D which cause D426 and R465 to bias the comparator AR403C in a latched state. The low input to U419 is inverted twice providing a low to U421-6 allowing LED D221 (HV TRIP) to illuminate and turning on the phototransistor in U421C to provide a logic level output for external use.

The output of AR403C will stay low keeping K406 de-energized until the high voltage monitor output from PS101 is increased above the setpoint voltage at AR403-9 and S206 (TRIP RESET) is pressed. When S206 is pressed, the ground will turn off U418 allowing the output of AR403C to swing positive. The high output of AR403C will bias Q408 to conduct which will energize K406 removing the tripped condition. The high output of

AR403 will again be inverted twice by U419A and U420F to turn off U421C which will turn off LED D221 (HV TRIP).

### 2.2.3. Power Level Trips

The power level trips operate in a similar manner except that the monitored signal is applied to the negative input terminal of AR403A and AR403B so the trip occurs on an increasing signal.

## 2.3. TEST FUNCTIONS

### 2.3.1. Power up Reset

There are five modes of operation - OPERATE, CAL HI, CAL LOW, CURRENT HV TEST. The mode is selected by pressing S202 (TEST/CALIBRATE) which steps decade counter U412 through successive test modes. When circuit power is applied, U413-9 will momentarily be at logic high until +15 VDC is discharged through C402 and R408. The logic high is twice inverted by UU413D and U413A to provide a logic high on U412-15 to reset the decade counter to its initial condition, placing the system in the OPERATE mode.

### 2.3.2. Time Delay Reset

The Time Delay Reset circuit provides an automatic switching function to return the NMP-1000 to the OPERATE mode from any previously selected Test mode. The RC time constant of R473 and C424 connected to U423A-9, provide a reset delay of approximately 50 seconds. Selecting a test mode applies +15 V to U423-5. This provides a logic low to U423-1 which after inversion through U423A and U423F, discharges C424 through D430. R473 and C424 start recharging at U423-9 which will provide a logic low at U423-8 which is then inverted through U423C to provide a momentary high logic level on the normally held low input to U423B. This pulse is then inverted at U423-4 and applied to U413-1 as a momentary low logic pulse which is inverted to provide a logic high to the RESET input of U412-15. This will reset the Function Select Counter to the OPERATE condition.

### 2.3.3. Function Select Counter

The function select counter enables sequential selection of the TEST/CALIBRATE modes and OPERATE mode of the NMP-1000. Manual selection

D106. The output of the rectifier is filtered by R104, R105, C106 and C107 and regulated by VR102 to provide regulated -15V dc.

#### 2.4.3. Compensating Power Supply

The secondary of T103 provides 200 volts to bridge rectifier D801 to D804 which is filtered and regulated by a shunt regulated bias supply for use in compensating ion chamber detectors. Output voltage from 0 to -150 V dc is adjustable by a 12-position selector switch (S2) for coarse adjustment; R210 is used for fine adjustment.

### 2.5. OUTPUTS AND ISOLATION DEVICES

#### 2.5.1. Bistable Trip Outputs

The bistable trips are provided with two sets of normally open and normally closed relay contacts. Choice of alarm contact state (open or close on alarm) is left to the customer. Contact are rated at 0.6 A at 125 V ac or 0.6 A at 110 V dc. An optically isolated logic output for external monitoring of trip status with 5000 volt protection is provided for each bistable trip (U421b, U421C, and U421D).

#### 2.5.2. Isolated Outputs

Two isolated power level outputs are provided with options to drive remote meters and recorders in a variety of configurations. Outputs corresponding to 0 to 120% full scale are available as 0 to 10 V dc and 4 to 20 mA while other output configurations can be optionally installed. The internal loop supply of AR1 and AR2 completely isolate the input loop from the output terminals and provide 1500 V RMS transient protection. Signal conditioning is accomplished through a modulator which converts the input voltage to a square wave that is passed through an isolation transformer and is demodulated and filtered to provide an output proportional to the input.

## SECTION I

DESCRIPTION1-1. GENERAL

1-2. The General Electric Picoammeter, Catalog Number 8NC01, is a current measuring instrument primarily designed to detect and measure currents from ionization chambers and other neutron detectors. The picoammeter is a high-gain, feedback device which achieves an exceptionally fast response time with negligible drift by the use of a wide-band, direct-coupled amplifier which is stabilized by a vibrating-reed, a-c coupled amplifier. An extremely high loop gain controls the output zero drift to within  $\pm 0.0025$  of full scale, eliminating the need for zero adjustment.

1-3. A maximum of three trip circuits can be provided in the picoammeter. The trip circuits operate when a pre-set point on any scale is exceeded. The trip point is adjustable from 0 percent to 150 percent of full scale and can be adjusted to trip on upscale or downscale input signals. Two trip outputs from each trip circuit are provided on the rear panel of the Picoammeter. One of the trip outputs is an electronic step, the other is a DPDT type relay contact which operates simultaneously with the voltage step. Switches are provided for trip test and reset.

1-4. Currents in the order of  $10^{-12}$  amperes to  $10^{-3}$  amperes can be measured by the picoammeter. Several range and scale variations (within the limits of  $10^{-12}$  to  $10^{-3}$  amperes) are available with the instrument. The meters can be calibrated to read D-C AMPERES, or the currents measured by the instrument can be utilized to indicate percent power or relative power, in which case the meters would read PERCENT POWER or RELATIVE POWER. The ranges and scales available with the picoammeter are outlined in paragraph 1-10. The unit is shown on engineering reference drawings in Section VI.

1-5. PICOAMMETER DESCRIPTION

1-6. The picoammeter consists of five basic subassemblies. They are: 1) Range Switch; 2) AC Amplifier; 3) DC Amplifier; 4) Power Supplies; and 5) Trip Units (when required). All of the component subassemblies are mounted in a standard 8-3/4 by 19 inch rack panel designed for flush mounting in a control console or cabinet or in a 9-3/8 x 19 inch power plant panel for semi-flush mounting. All electronic parts in the subassemblies are mounted on component boards through use of teflon stand-off terminals. A perforated metal cover is provided to protect personnel from electrical shock; and to protect the equipment from accidental damage.

Electronic parts are cooled by natural convection cooling air flow. Critical input circuits and measuring resistors are housed in a special moisture resistant shield box. Manufacturing details and component location is provided on engineering reference drawings in Section VI.

#### 1-7. RANGE SWITCH

1-8. The range switch is the control unit for the picoammeter and contains the range selector switch. As an option, when trip circuits are desired it also contains a trip test switch, a trip adjust potentiometer, and the trip reset switch. The range switch is mounted on the front panel of the picoammeter, or at a remote location depending on the application in which the picoammeter is being used. The range switch is shown on engineering reference drawing 932C641 in Section VI.

1-9. Since the picoammeter is an extremely high-gain instrument, capable of measuring dc current in the micromicroampere (picoampere) range, a switching function is sometimes necessary to bypass other instruments in the system while monitoring the lower current ranges. An auxiliary switch can be provided with the range switch for the purpose of bypassing certain less-sensitive instruments.

#### 1-10. OPTIONS.

1-11. Several variations of the picoammeter are available. The control package (range switch) containing the range selector switch, trip test, and optional trip reset switch can be mounted on the picoammeter front panel or furnished for remote mounting. In addition, other optional features for the picoammeter and the range switch can be provided. A list of the available options is outlined in paragraphs 1-12 through 1-17.

#### 1-12. Range and Meter Scale.

- a. Range of instrument is  $10^{-12}$  to  $10^{-3}$  amperes full scale in 19 steps. Meter reads D-C AMPERES on a dual scale, 0 to 1.0 or 0 to 2.5. Negative input to instrument.
- b. Range of instrument is  $10^{-9}$  to 1 in 19 steps. Meter reads RELATIVE POWER on a dual scale, 0 to 1.0 or 0 to 2.5. Negative input to instrument.
- c. Range of instrument is  $60 \times 10^{-8}$  to 150 percent power in 18 steps. Meter reads PERCENT POWER on a dual scale, 0 to 60 or 0 to 150. Negative input to instrument.
- d. Range of instrument is  $10^{-12}$  to  $10^{-3}$  amperes in 19 steps. Meter reads D-C AMPERES on a dual scale, 0 to 1.0 or 0 to 2.5. Positive input to instrument.

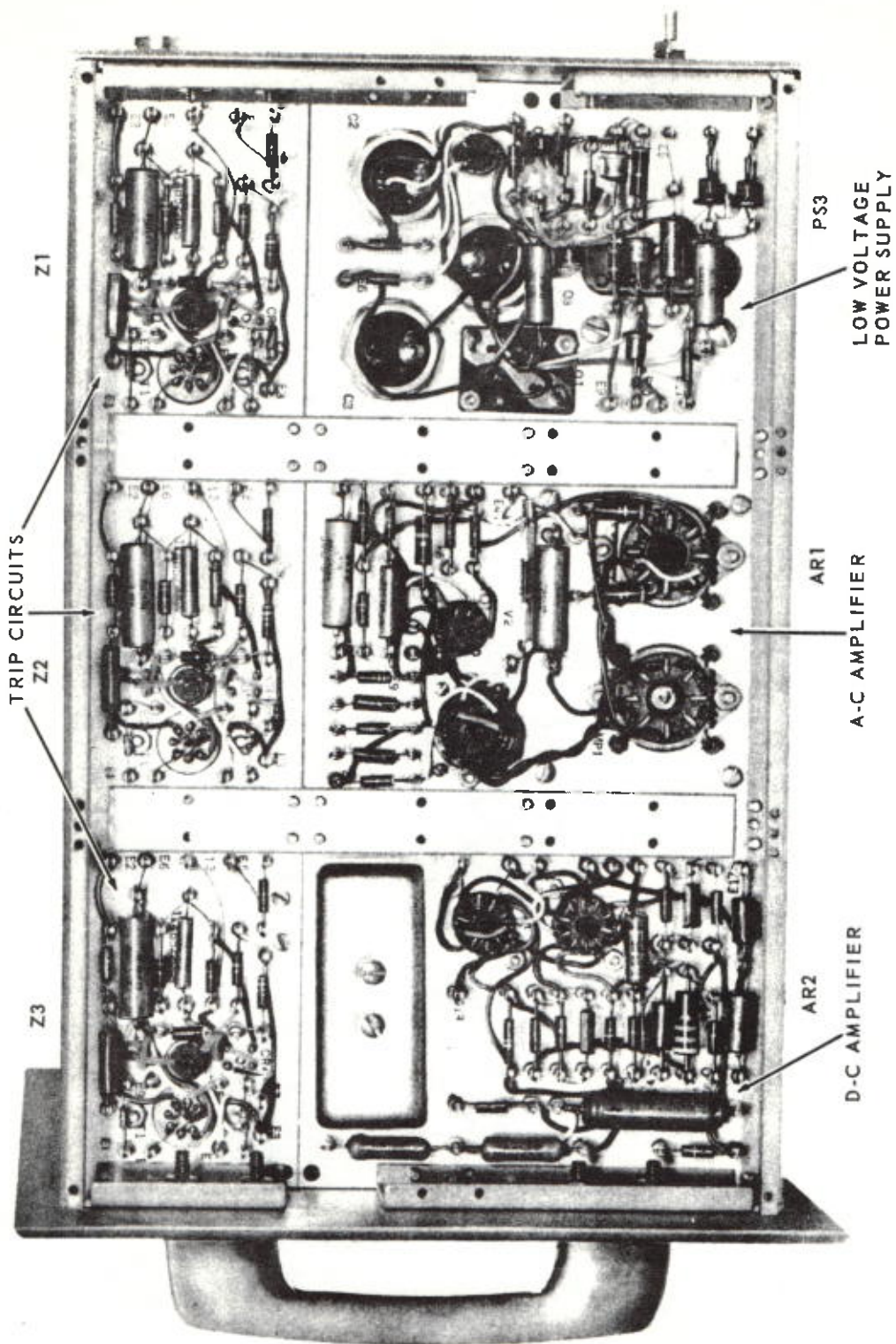

Figure 1-1. Picoammeter - Left Side View

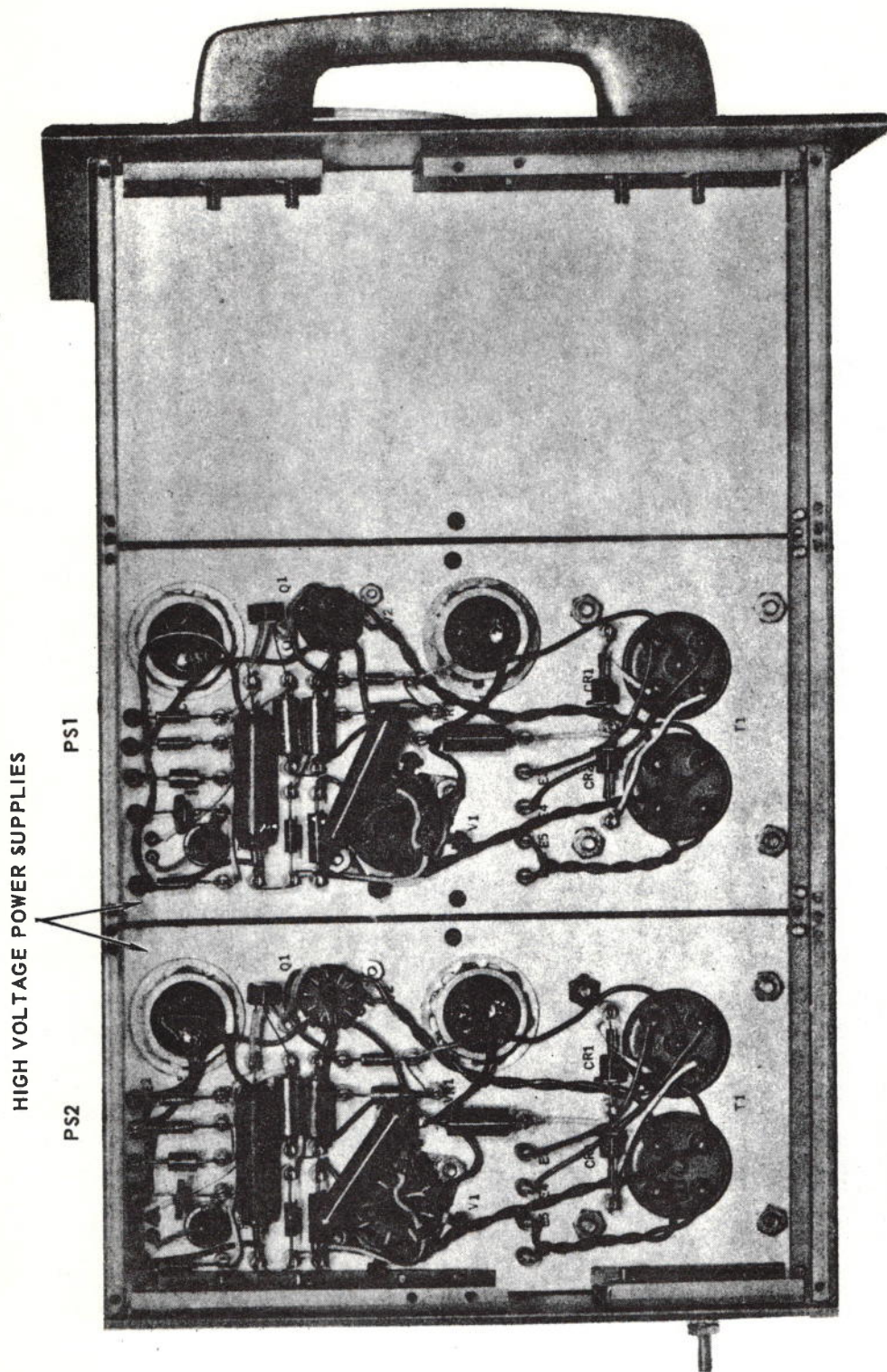

Figure 1-2. Picoammeter - Right Side View

458-2

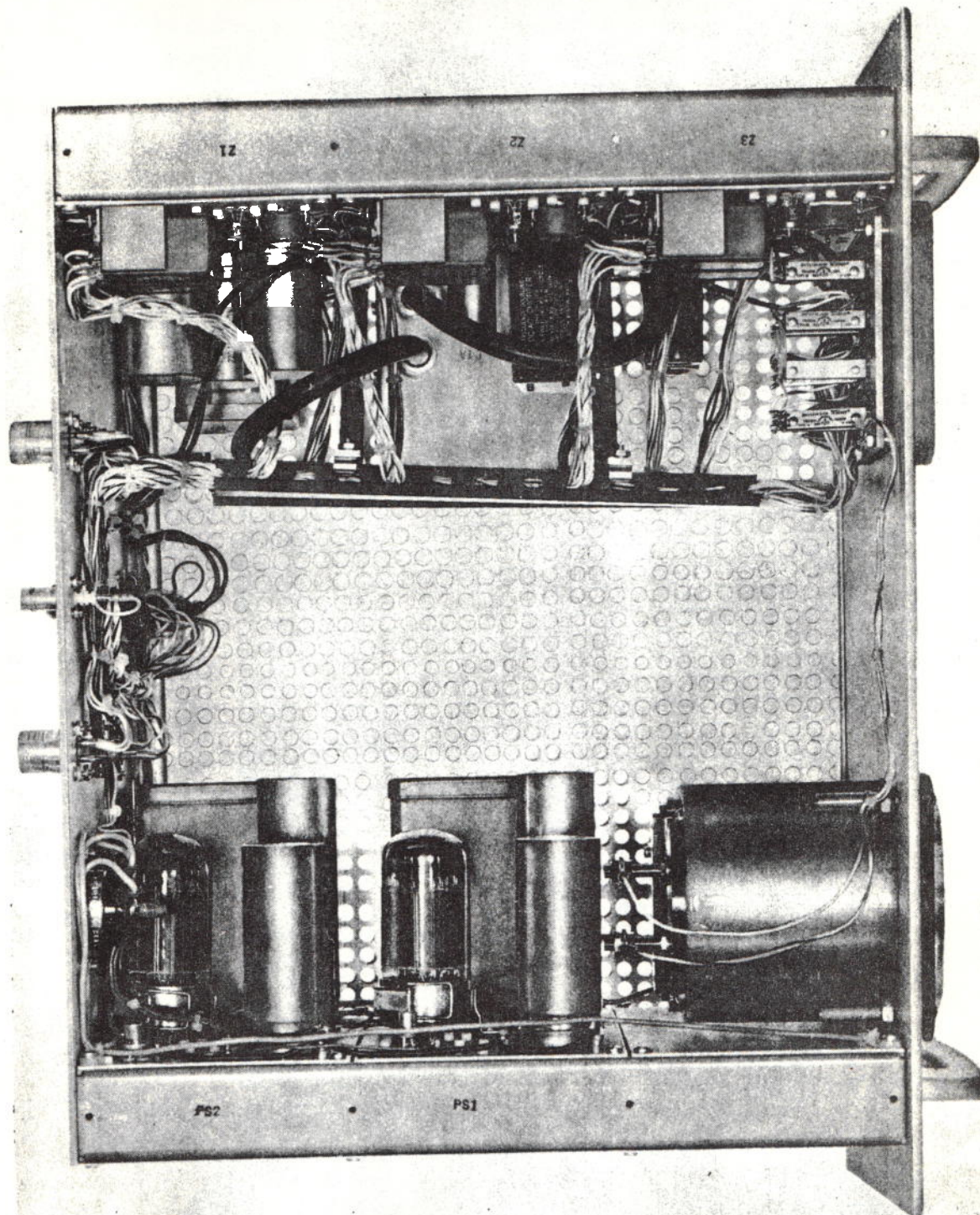

Figure 1-3. Picoammeter - Top View



- e. Range of instrument is  $10^{-9}$  to 1 in 19 steps. Meter reads **RELATIVE POWER** on a dual scale, 0 to 1.0 or 0 to 2.5. Positive input to instrument.
- f. Range of instrument is  $60 \times 10^{-8}$  to 150 percent power in 18 steps. Meter reads **PERCENT POWER** on a dual scale, 0 to 60 or 0 to 150. Positive input to instrument.

1-13. Range Switch Options.

- a. Range Switch without auxiliary switch mounted on picoammeter.
- b. Range Switch with auxiliary switch mounted on picoammeter.
- c. Range Switch without auxiliary switch for remote mounting (up to 200 feet).
- d. Range Switch with auxiliary switch and servo motor for remote mounting (for installations up to 10,000 feet).
- e. Range Switch with auxiliary switch for remote mounting (up to 200 feet).

1-14. Meter Type and Location.

- a. One (1) General Electric DB-18 meter, 7.1 inch scale, 1 percent accuracy, mounted on front panel of picoammeter.
- b. One (1) General Electric DB-18 meter, 7.1 inch scale, 1 percent accuracy, for remote mounting.
- c. Two (2) General Electric DB-18 meters, 7.1 inch scale, 1 percent accuracy, one mounted on picoammeter, one mounted remotely.
- d. One (1) General Electric DO-91 meter, 2.9 inch scale, 2 percent accuracy, mounted on front panel of picoammeter.
- e. One (1) General Electric DO-91 meter, 2.9 inch scale, 2 percent accuracy, for remote mounting.
- f. Two (2) General Electric DO-91 meters, 2.9 inch scale, 2 percent accuracy, one mounted on picoammeter, one mounted remotely.

1-15. Trip Circuits. A maximum of three trip circuits are available with the picoammeter. The trip circuits can be connected to provide trip functions on upscale or downscale input signals as follows:

- a. Trip Circuit Number 1
  - 1. Upscale trip with automatic reset
  - 2. Downscale trip with automatic reset
  - 3. Upscale trip with manual reset
  - 4. Downscale trip with manual reset
- b. Trip Circuit Number 2
  - 1. Upscale trip with automatic reset
  - 2. Downscale trip with automatic reset
- c. Trip Circuit Number 3
  - 1. Upscale trip with automatic reset
  - 2. Downscale trip with automatic reset

1-16. Panel Type

- a. Standard 8-3/4 by 19 inch relay rack panel for flush mounting.
- b. Power plant panel, 9-3/8 inches high by 19 inches wide for semi-flush surface mounting.

1-17. Instrument Color.

- a. Light Grey
- b. Special color as required

NOTE: Specification data sheets are provided at the back of this manual to assist in ordering the picoammeter for a particular application or installation. By checking the appropriate boxes and forwarding the data sheet with the order for the instrument, the required optional features can be furnished with the picoammeter.

1-18. CONSTRUCTION.

1-19. The picoammeter can be furnished with a front panel 9-3/8 inches high by 19 inches wide designed for semi-flush mounting in a control console (the units illustrated on the front cover are equipped with this type of front panel), or with a front panel 8-3/4 inches high by 19 inches wide designed for flush mounting in a standard 19-inch wide relay-rack panel assembly. The depth of the picoammeter is 13-3/8 inches.

1-20. Electronic components in the picoammeter are mounted on component boards through the use of teflon insulated stand-off terminals.

1-21. A perforated metal cover is provided to protect personnel from electrical shock and the equipment from accidental damage. The cover and chassis are designed to promote interior parts cooling by allowing natural air convection. The critical input circuits and measuring resistors are housed in a special moisture resistant shield box.

1-22. Construction details of the picoammeter are shown in Figures 1-1, 1-2, and 1-3.

1-23. SPECIFICATIONS.

1-24. Current Range. The current range is  $10^{-12}$  to  $10^{-3}$  amperes over-all.

1-25. Range Steps and Accuracy. Refer to table 1-1 for a listing of tolerances for meter accuracy corresponding to range steps.

Table 1-1. Meter Accuracy

Range Step	Meter Accuracy (% of full scale)	Range Step	Meter Accuracy (% of full scale)
$10^{-12}$	4%	$2.5 \times 10^{-8}$	3%
$2.5 \times 10^{-12}$	4%	$10^{-7}$	3%
$10^{-11}$	4%	$2.5 \times 10^{-7}$	3%
$2.5 \times 10^{-11}$	3%	$10^{-6}$	2%
$10^{-10}$	3%	$2.5 \times 10^{-6}$	2%
$2.5 \times 10^{-10}$	3%	$10^{-5}$	2%
$10^{-9}$	3%	$2.5 \times 10^{-5}$	2%
$2.5 \times 10^{-9}$	3%	$10^{-4}$	2%
$10^{-8}$	3%	$2.5 \times 10^{-4}$	2%
		$10^{-3}$	2%

Notes:

- 1) For meter reading, add 1 percent for DB-18 and 2 percent for DO-91
- 2) All figures are considered design center accuracy figures at 25°C and 50 percent relative humidity.

1-26. Maximum Operating Temperature. The maximum operating temperature is 50°C.

1-27. Drift.

- a. Short term - 0.08 percent of full scale
- b. Long term - 0.25 percent of full scale for life

1-28. Temperature Coefficient. Table 1-2 presents temperature coefficients expressed in terms of full scale voltage covering a temperature range of 0 to 50°C.

Table 1-2. Temperature Coefficients

Output Voltage	Recorder Voltage	Meter Reading
+0.08%/C°	+0.06%/C°	+0.08%/C°

1-29. Humidity Coefficient. Table 1-3 present humidity coefficients expressed terms of full scale voltages resulting from variations in humidity from 40 to 85 percent relative humidity.

Table 1-3. Humidity Coefficients

Switch Position	Output Voltage	Recorder Voltage	Meter Reading
1 to 15	0.05%/RH	+0.05%/RH	0.08%/RH
.5 to 19	0.10%/RH	0.10%/RH	-0.10%/RH

1-30. Response Time. The 0 to 63 percent of full-scale response time to each input current step is presented in table 1-4.

Table 1-4. Response Time

Range (Amperes)	Response Time (Milliseconds)
10 <sup>-9</sup> to 10 <sup>-3</sup>	Less than 2
10 <sup>-10</sup>	Less than 10
10 <sup>-11</sup>	Less than 100
10 <sup>-12</sup>	Less than 1000

1-31. With a 2000 MMFD cable capacity loading the input circuit, the response time values tabulated in table 1-4 remain valid. To minimize the effect of cable noise and statistical variations of input, a response time control is provided. With this control, the response time of the 10<sup>-12</sup> ampere range may be increased to ten seconds and proportionally less on other ranges.

1-32. Meters. The following specifications apply:

- a. General Electric Type DB-18, 7.1 inch scale, 1 percent accuracy, switchboard type meter.
- b. General Electric Type DO-91, 2.9 inch scale, 2 percent accuracy, panel type meter.

1-33. Input. The picoammeter can be connected to utilize either positive or negative input signals. Input is provided through a Type UG-61A/U connector.

1-34. **OUTPUT SPECIFICATIONS**

1-35. Recorder and Remote Meter. The following specifications apply:

- a. 0 to 10 millivolt, potentiometric type recorder; or 0 to 1 milliampere, galvanometric type recorder.
- b. An auxiliary output of 0 to 10 volts is available at connector J3.
- c. Connector available for remote meter.
- d. Connector Type MS3102A-18-1S

1-36. Electronic Trip Outputs. The following specifications apply:

- a. Up to three outputs, depending on number of trip circuits furnished with picoammeter.
- b. 25 milliamp maximum output from each trip unit.
- c. Electronic step is normally 12 volts; steps to 0 volts after trip level is reached.
- d. Connector Type MS3102A-16S-1S.

1-37. Trip Contacts. The following specifications apply:

- a. Up to three trip circuits available, each trip has 3 SPDT contacts.
- b. Contacts operate no later than 15 milliseconds after electronic trip.
- c. 115 volt a-c, 2 ampere contacts.
- d. Connector Type MS3102A-28-21P.

1-38. Auxiliary. An auxiliary connector is furnished which performs the following functions:

- a. Provides connections from the picoammeter to the range switch when the range switch is mounted remotely.
- b. Provides connections between the auxiliary switch (when furnished) and the range switch if the range switch is mounted on the picoammeter.
- c. Connector Type MS3102A-20-29S.

1-39. POWER REQUIREMENTS

- a. 115 volts a-c  $\pm 10\%$ , 50/60 cps, 60 Watts
- b. 2 ampere fuse provided on front panel of instrument

1-40. DIMENSIONS

- a. 8-3/4 inches high by 19 inches wide by 13-3/8 inches deep (with front panel designed for flush mounting in a relay-rack).
- b. 9-3/8 inches high by 19 inches wide by 13-3/8 inches deep (with front panel designed for semi-flush mounting in a control console).

1-41. APPLICATION NOTICE.

1-42. This instrument should not be altered, and should be operated and maintained in accordance with General Electric instructions. When it is used in safety-related applications, the system design should be such that this instrument's malfunction will not, of itself, impair the safety of the plant or process.

## MEMORANDUM

To: Dr. George Chabot, Chairman, Reactor Safety  
Subcommittee, RSC

From: Lee Bettenhausen, Reactor Supervisor 

Subject: Instrumentation Upgrade Status

Date: November 27, 1995

This reports on reactor instrument upgrade efforts for nuclear instrumentation and for radiation monitoring upgrades.

The nuclear instrumentation was ordered in July, 1995 in accordance with the attached specifications and bid. The instrumentation supplied in accordance with these specifications will perform the same functions in the same manner as the presently installed instrumentation. Thus, no changes in Technical Specification (TS) or Updated Safety Analysis Report (UFSAR) would be needed.

Since the new nuclear instrumentation is solid state and not an identical physical replacement for the existing vacuum tube instruments, an implementation plan, a test plan and a safety analysis per 10CFR50-59 is being developed.

The new radiation monitoring equipment has also been purchased from Nuclear Research Corporation. This equipment will use the existing cabling and safety logic. The detectors will be replaced by like detectors (GM's by GM's, ion chambers by ion chambers, etc.) and the readout units will be replaced by new signal processors. The replacement system has all of the same features of the existing system--high alarms, low alarms, trip on faults or loss of signal--but uses digital signal processing instead of analog signals. This new equipment will replace the fixed detectors throughout the reactor facility. The constant Air Monitor and Stack Monitor are not replaced by this purchase. Work is continuing to upgrade the air sampling monitors, but no concrete results can be reported. The radiation monitor upgrade, as is the case

for the nuclear instrumentation, will function in the same manner as the existing instruments so no changes to TS or UFSAR are needed. A safety analysis per 10CFR50-59 and a test and implementation plan to support the change are being developed.

cc: Reactor Safety Subcommittee Members  
P. C. Cataldo  
D. C. Medich  
T. Regan  
J. Giordano  
B. Stymest



#### DESCRIPTION OF CHANGE:

Replace existing 1950's General Electric vacuum tube Log N-Period Amplifier and Picoammeters with modern solid state General Atomic Logarithmic Power and Period and Linear Power Nuclear Instruments.

#### EFFECT OF CHANGE:

The replacement units will perform the identical functions more reliably. Trip units will provide the same logical inputs to safety circuits. The replacement units will operate with existing compensated ion chamber detectors. Maintenance and calibration will be simplified and replacement parts will be readily available.

#### SUPPORTING DOCUMENTS AND DRAWINGS:

Operation and Maintenance Manual, GA NLI-1000  
Operation and Maintenance Manual, GA NMP-1000  
Test Plan, Conversion of Nuclear Instruments at UMLRR  
Drawings (later)

## MEMORANDUM

To: Mary Kloppenburg, Director, Purchasing  
From: Lee Bettenhausen, Reactor Supervisor   
Subject: Bid Acceptance, Bid #16570  
Date: June 8, 1995

The evaluation of material submitted under Bid #16570 for Nuclear Instruments and Components for suitability of use in the University of Massachusetts Lowell Research Reactor (UMLRR) has been completed. Please accept the bid of General Atomics as stated in their proposal GACP 451-005 dated April 3, 1995, in the amount of \$64,400 to provide 2 Linear Power Channels (Model NMP-1000) with 1 installed Power Level Controller (NFC-1000) and 1 Logarithmic Power and Reactor Period Channel (NLI-1000) within 120 days of acceptance of this order. The bid of Gamma-Metrics, while fully responsive to the request for quotation, would cost \$75,567 for the same equipment and \$79,995 to use the equipment in the UMLRR.

cc:M. Montosalvo  
G. Kegel  
T. Breault



April 3, 1995

GACP 451-005

Ms. Mary P. Kloppenburg  
Purchasing Department  
University of Massachusetts-Lowell  
One University Avenue  
Lowell, MA 01854

Subject: Proposal Submittal  
Bid #16570  
Nuclear Instrumentation  
GA Proposal GACP 451-005

Dear Ms. Kloppenburg:

General Atomics (GA) is pleased to respond with its proposal GACP 451-005 listing its standard nuclear channels which are fully responsive to your Specifications for Nuclear Instruments. Product specifications for the model NMP-1000 and NLI-1000 and explanatory notations are attached as Attachment C.

GA understands the requirements of your general conditions concerning 10CFR21. We are also prepared to provide three copies of documentation as requested. A list of supply of similar instrumentation over the past five years is provided in Attachment B. Please treat this list as marketing data which is **GENERAL ATOMICS PRIVATE DATA**.

Prices and Terms and Conditions upon which these prices are based are provided as Attachment A. The executed Affidavit of Compliance included in the subject bid request from you is also enclosed. The prices remain valid for 90 days. Extension of price validity will be considered upon request from you. Delivery can be expected within 120 days following acceptance of your order by GA.

Thank you for your interest in GA. If you have any contractual questions, I can be reached at (619) 455-2733 (fax: 455-3545). For technical clarifications, please contact Roger Schlicht at (619) 455-4255 (fax: 455-4169). We are very interested in supplying this system to the University and look forward to receiving an order from you.

Sincerely yours,

A handwritten signature in black ink, appearing to read "R. B. Perkins", written over a horizontal line.

R. B. Perkins  
Contracts Manager

Attachments

Attachment C

1. SPECIFICATIONS NMP-1000 Linear Power Channel

Input Range	<p><math>10^{-11}</math> to <math>10^{-4}</math> A or <math>10^{-10}</math> A to <math>10^{-3}</math> A in seven one decade ranges.</p> <p>Self-bailing illuminated pushbutton or automatic range switching (manual or auto, operator selected).</p> <p>Provision for remote range switching.</p>						
Linearity	<p><math>\pm 1.0\%</math> of full scale upper 5 ranges; <math>\pm 2.5\%</math> of full scale lower 2 ranges.</p>						
Temperature coefficient	<p><math>\pm 0.15\%/^{\circ}\text{C}</math> maximum in the range of <math>10^{\circ}</math> to <math>55^{\circ}\text{C}</math>. (See note 2)</p>						
Calibration/test	<p>Two fixed currents for calibration, one adjustable current for multi-range function test and trip testing.</p> <p>HV trip test, test modes selected sequentially by front panel control.</p>						
Response time constant	<p>1 msec <math>10^{-4}</math> to <math>10^{-3}</math> A; 10 msec <math>10^{-9}</math> to <math>10^{-8}</math> A; 100 msec to <math>10^{-11}</math> to <math>10^{-9}</math> A.</p>						
Outputs	<p>Remote meter: 0-10 V full scale</p> <p>Remote meter: 0-1 mA full scale</p> <p>Recorder: 0-0.1 V full scale</p> <p>Recorder: 0-1.0 V full scale</p> <p>Optional: 4-20 mA full scale</p> <p>High voltage: 300 to 800 V dc at 2.6 W</p> <p>Compensation: 0 to -150 V dc</p>						
Bistable trips (see note 1)	<table border="0"> <tr> <td style="vertical-align: top;">High voltage trip</td> <td style="vertical-align: top;">Adjustable with +5 V</td> </tr> <tr> <td style="vertical-align: top;">High power trip</td> <td style="vertical-align: top;">logic level and two</td> </tr> <tr> <td style="vertical-align: top;">High power alarm</td> <td style="vertical-align: top;">form C contacts per trip</td> </tr> </table>	High voltage trip	Adjustable with +5 V	High power trip	logic level and two	High power alarm	form C contacts per trip
High voltage trip	Adjustable with +5 V						
High power trip	logic level and two						
High power alarm	form C contacts per trip						
Power required	<p>117 V ac <math>\pm 10\%</math>, 50/60 Hz at 1.0 A</p>						

- Notes:
1. An additional trip board will be added to the unit to meet the University specification.
  2. Within the range of  $20^{\circ}$  to  $30^{\circ}\text{C}$  the unit meets the  $\pm 0.15\%$  per  $^{\circ}\text{F}$  requirement of the University specification.

**2. Specifications** NLI-1000 Logarithmic Power and Reactor Period Channel

**Input Range:**

**Current** .....  $1 \times 10^{-10}$  to  $3 \times 10^{-2}$  Amperes

**Linearity (Log**

**Conformity)** .....  $\pm 3\%$  Full scale equivalent above  $\gamma$  compensation (temperature range of  $20^\circ$  to  $30^\circ$  C).

**Temperature**

**Coefficient** .....  $\pm 0.15\%$  per  $^\circ\text{C}$  (maximum) over the temperature range  $10^\circ$  to  $55^\circ\text{C}$ . (See note 1)

**Calibration/Test** .....

2 fixed currents for calibration; 1 adjustable current for trip testing; HV trip test; period trip test. Test modes selected sequentially by front panel or remote control.

**Response Time Constants** ..  $< 5$  mSec.

**Outputs:**

**Local Meter** .....  $10^{-4}$  to 100 Percent Power (See note 2)  
0 to 1000 VDC  
-30 to +3 Second Period

**Remote Meter - Isolated..** 0-10 V Full Scale, 0-1 mA Full Scale, 4-20 mA Full Scale (optional)

**Recorder - Non Isolated...** 0-0.1 V Full Scale, 0-1 V Full Scale

**High Voltage** ..... +300 to +800 VDC @ 2.6 Watts

**Bistable Trips** ..... 1 - High Voltage, 1 - High Power, 3 - Configurable Power (Increasing or Decreasing), 1 - Period (All are adjustable with two form C contacts and one logic level output per trip)

**Power Requirements** ..... 117 VAC  $\pm 10\%$ , 50/60 Hz @ 1.0 Amp

**Notes:**

1. Within the range of  $20^\circ$  to  $30^\circ$  C the unit meets the  $\pm 0.15\%$  per  $^\circ\text{F}$  requirement.
2. Other scales available, such as  $10^{-5}$  to 200%, etc.

2/24/95

## SPECIFICATIONS FOR NUCLEAR INSTRUMENTS

### UML RESEARCH REACTOR

#### Logarithmic Power and Reactor Period Channel (1 required)

Signal Input from Compensated Ion Chamber:

Current Range:  $<1E-10$  amps to  $1E-3$  amperes

Neutron Flux Range: 3 nv to  $3E11$  nv

Purpose: Measure reactor power (neutron flux) continuously from startup (zero power) to full power (presently 1 Megawatt). Provide logarithmic indication of reactor power. Provides indication of reactor period associated with changes in power level and associated safety-related trips and interlocks.

Minimum of 4 safety-related trips associated with reactor period are required:

1. Upscale period trip providing 0 vdc when tripped, else 12 vdc, to electronic reactor trip logic circuit. Variable setting with typical trip range from 10 seconds to 3 seconds.
2. Upscale trip with open relay contacts when tripped, else closed contacts, to scram relay safety chain. Variable setting with typical trip range from 10 seconds to 3 seconds.
3. Upscale trip with open relay contact when tripped, else closed contact to provide prohibition of automatic power control. Variable setting with typical trip range from 30 seconds to 10 seconds
4. Upscale trip with open relay contact when tripped, else closed contact, to (1)prohibit control blade withdrawal on short reactor period and (2) annunciation of short reactor period. Variable setting with typical trip range from 60 seconds to 10 seconds

If high voltage power to ion chamber is included with instrument, a relay safety chain trip with open relay contacts upon high voltage drop of 100 vdc from setpoint is required.

UMLRR INST SPEC

2/24/95

Loss of power to the instrument or internal power or circuit failures shall cause the safety-related trips to assume their tripped states and result in reactor scram and rod motion prohibition.

Instrument shall provide indication of logarithmic power and reactor period continuously on a remote operator console (presently two 0-1 ma meters). Trip status indication for each trip function shall be provided by indicator lights on the instrument or the remote operator console or both.

Instrument shall have internal calibration checks for low range (approx 1E-2 to 1E-3%) and high range (approx 1 to 10%) of power and for period trip setpoints in the range 3 to 30 seconds.

Accuracy and linearity shall be +/- 3% or less.

Instrument shall provide output signal to operate 0-10v chart recorder for both logarithmic power and period indications.

Sensitivity to temperature and humidity shall be less than 0.15% per degree F or percent RH.

Instrument shall operate reliably on 110-120 vac unconditioned 60 Hz power.

Physical Specifications:

Rack mounting to fit panel 9 inch by 19 inch opening. If instrument modules supplied as Nuclear Instrumentation Modules (NIM), supplier will furnish NIM bins and power supply units to fit rack mounts and operate from 110 vac.

Signal connection for HN coaxial cable connector

All other connections to use readily available MIL standard or equivalent connectors.

Power cord to connect to 110 vac outlet with ground

## SPECIFICATIONS FOR NUCLEAR INSTRUMENTS

### UML RESEARCH REACTOR

#### Linear Power Channel (2 required)

##### Signal Input from Compensated Ion Chamber:

Current Range:  $<1\text{E}-10$  amps to  $1\text{E}-3$  amperes

Neutron Flux Range: 3 nv to  $3\text{E}11$  nv

Purpose: Measure reactor power (neutron flux) continuously from startup (zero power) to full power (presently 1 Megawatt). Provide linear indication of reactor power and associated safety-related trips and interlocks.

Minimum of 4 safety-related trips associated with reactor power level are required:

1. Upscale high level trip providing 0 vdc when tripped, else 12 vdc, to electronic reactor trip logic circuit. Variable setting with typical trip at 120% of selected range.
2. Upscale trip with open relay contacts when tripped, else closed contacts, to scram relay safety chain. Variable setting with typical trip at 120% of selected range .
3. Upscale trip with open relay contact when tripped, else closed contact, to provide (1) control rod withdrawal inhibition and (2) annunciation of high power level. Variable setting with typical trip at 110% of selected range
4. Downscale trip with open relay contact when tripped, else closed contact, to prohibit control blade withdrawal on downscale indication . Variable setting with typical trip range from 5% to 20% of selected scale. Provision for bypass of the rod withdrawal prohibition on the most sensitive range setting.



UMLRR INST SPEC

2/24/95

If high voltage power to ion chamber is included with instrument, a relay safety chain trip with open relay contacts upon high voltage drop of 100 vdc from setpoint is required.

Loss of power to the instrument or internal power or circuit failures shall cause the safety-related trips to assume their tripped states and result in reactor scram and rod motion prohibition.

Instrument shall provide indication of linear power continuously on a remote operator console (presently 0-1ma meter). Trip status indication for each trip function shall be provided by indicator lights on the instrument or the remote operator console or both.

Instrument shall have internal calibration checks for low range (approx 1E-2 to 1E-3%) and high range (approx 1 to 10%) of power.

Accuracy and linearity shall be +/- 3% or less.

Sensitivity to temperature and humidity shall be less than 0.15% per degree F or percent RH.

Instrument shall provide output signal to operate 0-10v chart recorder for linear power indication.

Instrument shall operate reliably on 110-120 vac unconditioned 60 Hz power.

Physical Specifications:

Rack mounting to fit panel 9 inch by 19 inch opening. If instrument modules supplied as Nuclear Instrumentation Modules (NIM), supplier will furnish NIM bins and power supply units to fit rack mounts and operate from 110 vac.

Signal connection for HN coaxial cable connector

All other connections to use readily available MIL standard or equivalent connectors.

Power cord to connect to 110 vac outlet with ground

## SPECIFICATIONS FOR NUCLEAR INSTRUMENTS

### UML RESEARCH REACTOR

#### Power Level Controller (Optional)

Signal input from selected linear power channel is compared with operator demanded power to control position of regulating rod to maintain constant demanded power.

Purpose: To maintain an operator-selected constant reactor power by suitably positioning the reactor regulating rod.

The controller drives a two-phase motor attached to the regulating rod. A tachometer provides a voltage feedback to the controller to promote stability.

The operator demanded power input shall originate from the remote operator console. The demanded power shall be displayed on the remote console.

The automatic power level controller shall be actuated or turned off from the remote operator console.

The automatic power level controller shall disengage when the signalled power deviates from the demanded power by more than  $\pm 20\%$ .

Loss of power to the instrument or internal power or circuit failures shall cause the automatic power level controller to disengage.

Accuracy and linearity shall be  $\pm 3\%$  or less.

Sensitivity to temperature and humidity shall be less than  $0.15\%$  per degree F or percent RH.

Instrument shall operate reliably on 110-120 vac unconditioned 60 Hz power.

UMLRR INST SPEC

2/24/95

Physical Specifications:

Rack mounting to fit panel 9 inch by 19 inch opening. If instrument modules supplied as Nuclear Instrumentation Modules (NIM), supplier will furnish NIM bins and power supply units to fit rack mounts and operate from 110 vac.

All connections to use readily available MIL standard or equivalent connectors.

Power cord to connect to 110 vac outlet with ground

## STEPS FOR NEW NUCLEAR INSTRUMENTS

1. DEVELOP DESCRIPTION OF CHANGE
2. WRITE INSTRUMENT IMPLEMENTATION PLAN
3. DESIGN INTERCONNECTIONS AND TEST PLAN
4. PERFORM SAFETY ANALYSIS AND 10CFR50.59 REVIEW  
PRESENT TO RSSC  
COURTESY INFO LETTER TO NRC
5. DRAFT PROCEDURES- NEW ROS, CPS, SPS  
PRESENT TO RSSC
6. INSTALL NEW INSTRUMENTS PER 2. AND 3. ABOVE; EXECUTE TEST PLAN
7. TRIAL USE OF PROCEDURES, DEBUG, GO FINAL
8. PLACE NEW INSTRUMENTS IN REGULAR SERVICE



August 16, 1995

University of Massachusetts  
Radiation Laboratory  
Lowell, MA 01854

ATTENTION:       LEE BETTENHAUSER, REACTOR SUPERVISOR  
508/934-3365, 508/459-6561 (FAX)

REFERENCE:       1)     MEETING OF AUGUST 1, 1995  
                  2)     NRC PROPOSAL #P95-695

Dear Mr. Bettenhauser:

*It was a pleasure meeting with you a couple of weeks ago. As promised, enclosed is Nuclear Research Corporation's (NRC) pricing which we discussed. Technical data sheets were not included with this quotation as you were previously given this information during my visit.*

*We look forward to your favored response and if you have any questions or need any additional information please do not hesitate to contact me at 215/343-5900 or fax 215/343-4670. NRC appreciates your interest and will support your efforts fully to your complete satisfaction. Please note, the optional information relating to the Continuous Air Monitors will be sent to you in the near future.*

*Sincerely,*

NUCLEAR RESEARCH CORPORATION

A handwritten signature in black ink, appearing to read 'Tom'.

Thomas E. O'Malley  
Marketing Manager  
TEO/dsm  
Enclosure  
cc: EMP, File

# ARM-610

## AREA RADIATION MONITORING SYSTEM



Detector/Local Microprocessor



Local Alarm

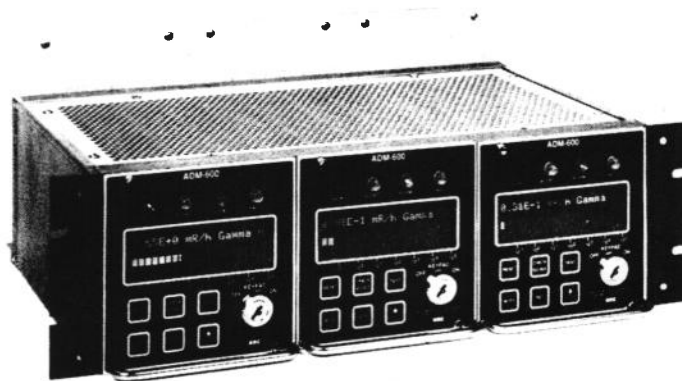

NIM  
Remote Display and Control

### MAJOR ASSEMBLIES:

- Detector, Model GP-100C
- Local Readout and Alarm, Model ADM-610 Series
- Wall Mounted Detector Bracket, Model AX-50
- Control Room Unit, Model ADM-600 Series
- 19 Inch NIM-BIN Chassis
- Ion Chamber Detector, Model IP-100C
- Local Alarm and Beacon, Model AX-300

### FEATURES:

- Wide Dynamic Measurement Range
- Time-To-Count Technology
- Smart Detector Design
- Multi-Probe Operation
- Analog and Digital I/O
- Battery Backup Power System
- Distributed Networking Capabilities

## SCOPE:

This bulletin on the Gamma Area Radiation Monitor provides the basic design and description of the components that are necessary for continuous monitoring of background radiation levels in order to assure safe working levels for personnel involved in daily routines in facilities that use radioactive materials.

## MONITOR DESCRIPTION:

The ARM-610 Series Monitor from NRC Industries offers a full nine decades of measurement accurate to within 10% in a configuration compatible with existing monitor installations. Based on the successful NRC ADM-300 series survey meter, The ARM-610 series consists of a detector, a local readout alarm module, and an optional remote control unit sized for standard 19" NIM-BIN Series Rack Mounts. The GP-100C Detector will function reliably up to 500 ft. from the ADM-610 series local module. The optional ADM-600 series Control Unit will allow remote display and control up to one mile away from the ADM-610.

The Mean Time Between Failures (MTBF) rating is an impressive five years for the ARM-610 Series, and Total Integrated Dose (TID) allowance exceeds 10,000 Roentgens.

Dose measurement is achieved by the exceptionally reliable and unique Time-To-Count principle developed and patented by the NRC Industries Division of Nuclear Research Corporation. This technique assures highly linear and extended range readout with Geiger-Mueller Detectors. This is not achievable when G-M tubes are operated in the conventional pulse-counting mode.

## DETECTOR, MODEL GP-100C:

Two rugged halogen-quenched G-M tubes serve as the basic detection elements. Dose rate measurement is achieved using the NRC patented "Time-To-Count" circuitry. In a "Time-To-Count" mode, a microprocessor program precisely controls high voltage to the detector tube, measures the time for the tube to detect the first count, and then imposes a delay time in excess of normal tube dead time, making it possible to reliably measure radiation levels with  $\pm 10\%$  accuracy over the instrument's range.

## LOCAL READOUT AND ALARM, MODEL ADM-610 SERIES:

The Local Readout and Alarm is housed within a NEMA-12 Enclosure and can be located within 500 feet of the Model GP-100C Detector.

The ADM-610 series are menu-driven intelligent ratemeters with features including communications with a host computer, internal diagnostics, and software control over peripheral hardware. The ADM-610 series is also designed to handle multiple digital I/O and analog inputs. It provides the operating voltages, displays and controls necessary to operate and control the detectors and preamplifiers.

The ADM-610 series uses a programable dot matrix display. A digital display is used for accuracy and analog bar scale is used for trending. Other user selectable modes provide display and control functions such as alarm setpoints, calibration, etc. Large, bright bit-mapped displays show three significant digits plus a floating decimal and indication of values in mR/hr, R/hr, or kR/hr.

Each alarm activates an associated cabinet mounted alarm indication. The high alarm activates a red flashing light and fast ringing alarm bell or buzzer; the warning alarm activates a non-flashing white light and the above mentioned bell; while the failure alarm deactivates a non-flashing, green light. All lights are visible at a distance of 50 feet. The high and warning alarms remain on until the audible alarm has been acknowledged and the alarm conditions removed. All alarms can be adjusted and reset without removing the instrument from service, and can be set to annunciate at any point over the range of the ADM-610 series.

The ADM-610 series provides multiple RS-232/RS-485 communication links for computer based, remote control and monitoring. The ADM-610 series stores historical data in a non-volatile 8k memory which is backed-up by a Lithium battery. The data stored includes one minute, ten minutes, one hour, and daily readings. At least 30 data points are stored for each of these. A real time clock in the ADM-610 series logs the date and time. The historical data can be downloaded to an IBM PC-compatible computer.

## OPTIONS:

### REMOTE DIGITAL RATEMETER, MODEL ADM-600A SERIES:

The ADM-600 remote digital ratemeter series communicates with the ADM-610 series local digital monitor through a serial communication data highway, providing highly reliable data transmission over a small, economical 2-twisted pair communications cable.

The ADM-600 series operates in exactly the same manner as the ADM-610 series, except that it does not have on-line monitoring capabilities during power failure.

However, when power is restored, the ADM-600 series immediately updates its history files from the ADM-610 series. The ADM-600 series remote digital ratemeter is 7.00 inch H x 5.75 inch W x 12.00 inch D and fits in a NIM-BIN style rack chassis. The CR-600 Chassis holds up to three ADM-600 series units and fits in a standard 19 inch control room rack.

### LOCAL ALARM AND BEACON, MODEL AX-300:

The AX-300 alarm enclosure provides a high visibility beacon and loud alarm bell or buzzer mounted adjacent to the detector. The detector mounting bracket AX-50 can be directly attached to the AX-300. An analog meter is provided with the AX-300 for local readout.

### IP-100C ION CHAMBER DETECTOR:

The NRC Model IP-100 Ion Chamber Detector is a proportional detector intended for the measurement of gamma fields. The IP-100 is especially suited in applications where transient radiation levels may occur that might go undetected by other measurement methods.

The IP-100 employs an ion chamber used in proportional region of operation. This technique takes advantage of the high current gain of the ion chamber, simplifying the measurement of its output current. An automatic switch over to ion chamber region provides a wide dynamic range.

### CHECK SOURCE:

A solenoid actuated check source can be furnished to indicate in the range of approximately 10 mR/hr.

## SPECIFICATIONS:

### GAMMA DETECTOR, MODEL GP-100C:

Weight: 3 lbs.  
Size: 2.5 inch diameter x 8 inch long.  
Enclosure: Moisture proof, aluminum exterior, Stainless steel optional.

Operating temperature: -30°C to 60°C.  
H.V. Supply: Internally generated  $\pm 250V$ .  
Operating humidity: Zero to one hundred percent.  
Detector: Two G-M tubes, halogen quenched operated in NRC's patented Time-To-Count mode.

Range: 10 uR/h to 10,000 R/h.

Gamma sensitivity: Low range tube, 700 CPM/mR/h.  
High range tube, 4.2 CPM/mR/h.

Energy range: 80 KeV to 2.0 MeV.  
Accuracy:  $\pm 10\%$  of true field intensity.  
Linearity:  $\pm 5\%$ .  
Response: 2 to 5 seconds.  
Check source: 0.1uCi of Sr-90 internally mounted.

### GAMMA DETECTOR, MODEL IP-100C:

Weight: 3 lbs., 3 ounces.  
Size: 2.5 inch diameter x 12½ inch long.  
Enclosure: Moisture proof, aluminum exterior.

Operating temperature: -10°C to 50°C.  
H.V. supply: Internally generated, 2,000V.  
Range: Steady state, 0.1 to 100,000 mR/h.  
Transient, 1,000 R/hr at 10 uSec bursts and 100 Hz repetition rate.

Output: Pulse train with repetition frequency proportional to the input current.  
Low range: 0.4 uR per pulse.  
High range: 400 uR per pulse.

Output levels: +5V and ground.

Energy response:  $\pm 20\%$  from 50 KeV to 1.25 MeV.  
Over ranging: No loss of output for fields up to 1,000 R/h.

Accuracy: Within  $\pm 20\%$  of true reading.  
Linearity:  $\pm 10\%$  each range.  
Check source: 1.0uCi of Sr-90.





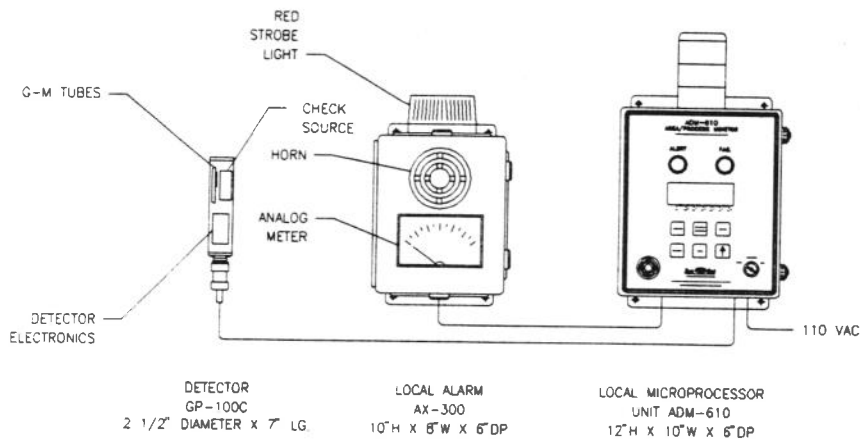

A. AREA MONITORING ARRANGEMENT WITH LOCAL PROCESSOR AND ALARM INDICATION AT DETECTOR

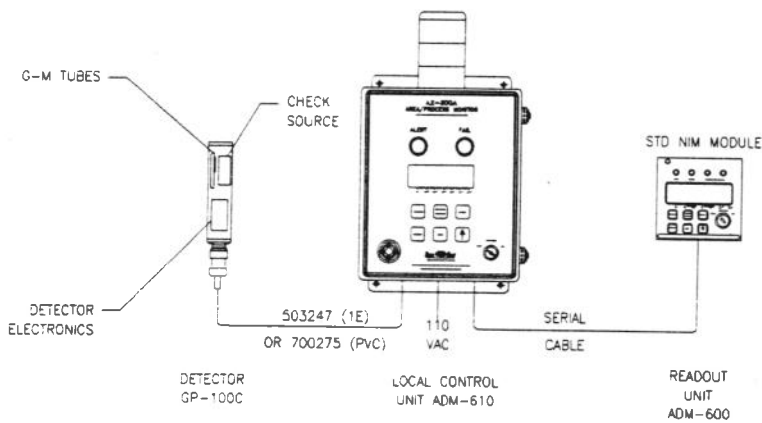

B. AREA MONITORING CHANNEL ARRANGEMENT WITH LOCAL AND REMOTE CONTROL

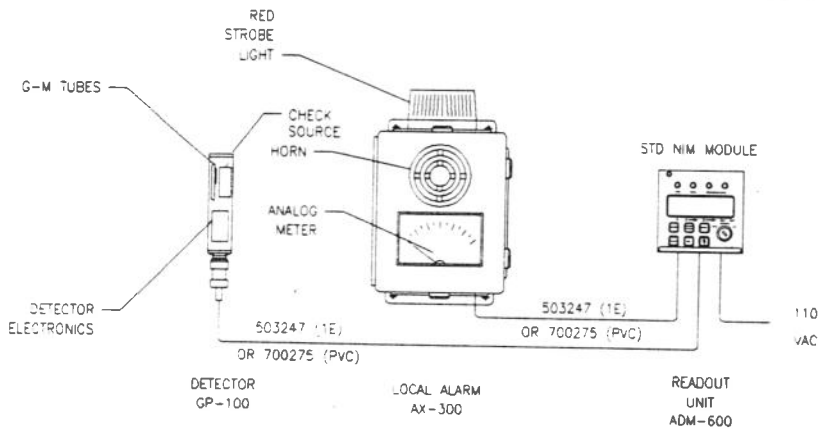

C. AREA MONITORING CHANNEL ARRANGEMENT WITH REMOTE CONTROL AND LOCAL ALARM/DISPLAY

For additional information please contact:

**NUCLEAR RESEARCH CORPORATION**  
125 TITUS AVENUE, P.O. BOX H, WARRINGTON, PA 18976  
Phone: (215) 343-5900 / Fax: (215) 343-4670

**NUCLEAR RESEARCH CORPORATION**  
58 RICHBOYNTON ROAD, DOVER, NJ 07801  
Phone: (201) 361-5600 / Fax: (201) 361-9506



**RemRad**  
Radiation Monitoring Systems

# ADM-600 SERIES MULTI-FUNCTION SMART RATEMETERS



## MAJOR ASSEMBLIES:

- Central Processor Board
- Input/Output Board
- Relay Board
- Communication Board
- Mother Board
- Power Supply Module
- User Interface/Control Module
- NEMA or NIM Enclosures

## FEATURES:

- Multi-Function Capabilities
- Advanced Digital Filtering
- CMOS Low Power Technology
- Remote Auto Calibration and Self Diagnostics
- Data Storage in Non-Volatile Memory
- Multiple Digital I/O and Inputs
- Process Control & Communication

NUCLEAR RESEARCH CORPORATION  
125 TITUS AVENUE, P.O. BOX H, WARRINGTON, PA 18976 • Phone (215) 343-5900 • Fax: (215) 343-4670

#### SCOPE:

The NRC ADM series is a microprocessor based multifunction smart ratemeter design with autoranging digital/analog display for a wide variety of applications. Using a digital readout as well as an analog display for trending purposes, the ADM series is used with a host of smart probes for monitoring all types of radiation; Alpha, Beta, Gamma, X-Ray, and Neutron.

Designed to operate as a multi-function ratemeter, the ADM series can accept a variety of inputs from different style detectors for configuration as an area monitor, a process monitor, or other types of radiation monitoring systems.

The ADM automatically interrogates each probe port to determine probe type and relative calibration constants. The displayed units are automatically adjusted to correspond to the probe type. The ADM can operate in a direct count method or Nuclear Research Corporation's patented "Time-To-Count" method. Hence, the ADM can operate with any "Smart Probe" produced by Nuclear Research Corporation.

The ADM-600 series is packaged in a variety of enclosures to allow placement of the unit in local or remote applications. Built-in radiation alarms (high-high, high, failure) are user adjustable and include DPDT relay contacts to annunciate alarms. Modular digital circuitry used in the ADM series permits rapid and cost-effective repairs with minimized downtime and maximum flexibility.

#### DISPLAYS:

The ADM-600 series uses a high visibility programmable dot matrix display. A digital display is used for accuracy and an analog bar graph is used for trending. Other user selectable modes provide display and control functions. High, Warn, and Fail alarm conditions are indicated by red, amber, and white lights located on the front panel. A normal operating condition is indicated by a green light.

The ADM series provides state-of-the-art radiation detection and measurement capabilities during normal or emergency conditions. Its human engineered design and simplicity of operation offer unique features such as remote calibration and built-in diagnostics. A computer based, real-time, cost-effective monitoring system comprised of a network of ADM's can easily be configured using the serial communications ports.

#### COMMUNICATIONS:

The ADM-600 series utilizes a serial communication link for remote communications with a host computer or remote display. The serial link is configured to use an RS-485 protocol. An RS-232C/RS-422 communication protocol is also available. The RS-232 link can be used for limited distance communications with a remote display or computer for debugging purposes.

The RS-485 multi-drop communication protocol is suggested for applications where many ADM's are to be connected to a single host computer, and where distances can reach one mile. The RS-485 standard allows the connection of up to 32 ADM-600's on a single communication loop (2 wire plus ground). The implementation of RS-485 provides a cost effective means of connecting many ADM's to a single host computer.

#### CONTROLS:

- Key switch: Provides primary ON/OFF control of unit and lock-out option to eliminate tampering.
- Keypad: Selects operating modes, and allows entry of information.

#### HOST PROGRAM/HISTORICAL DATA:

Historical data for all NRC detector types is stored within the ADM-600 series for later archival and analysis. Each history point contains the data and time of the history point, the data collection period, the accumulated dose and counts. Historical data stored within the ADM's can be downloaded to a computer as required.

Two host software programs are available from NRC. ADMCOM is available for connecting a single ADM to a PC. ADMCOM provides both remote readout capability and control over ADM functions such as alarm set points, historical data collection and time-keeping.

A comprehensive Radiological Assessment Display and Control Software (RADACS) is available from NRC for connecting multiple ADM's to a single PC, creating a complete monitoring network. Custom graphical displays depicting facility layouts are included in the software design.

## MODEL DESIGNATION TABLE

### EXAMPLE: ADM-600A SERIES

0= 8 Bit Microprocessor

6= 16 Bit Microprocessor

0= NIM Bin Packaging

1= NEMA Wall Mount Packaging

3= ADM Portable Survey Meter

6= ADM Fixed Monitor

#### ADM-300:

ADM-300 series units are battery operated survey meters operated with a variety of external smart probes.

#### ADM-600:

ADM-600 series instruments are fixed installation universal ratemeters described in this brochure.

#### ADM-61\_:

ADM-61\_ series instruments are packaging in NEMA wall mounted enclosures and have added features such as an additional level of batteries that provides operation in excess of two hours after loss of primary power and large visual indicators for annunciation of alarm conditions in work areas.

#### ADM-60\_:

ADM-60\_ series instruments are packaged in NIM Bin enclosures for mounting three wide in a nineteen inch wide electronics enclosure. ADM-60\_ units use interchangeable printed circuit board assemblies with their associated ADM-61\_ counter part.

#### ADM-6\_0:

ADM-6\_0 series instruments use 8 bit microprocessors and data buss and provide reliable operation in accelerator, Nuclear power plant and routine radiation monitoring applications.

The 8 bit ADM units can be networked in channel quantities up to 64 stations. Each 8 bit ADM includes processing of data for one or two separate detectors, one RS-232C and one RS-485 serial communications port, and two analog outputs (either voltage or current signals) in addition to the standard features included in all ADM-series instruments.

#### ADM-6\_6:

ADM-6\_6 series instruments use 16 bit microprocessors and data buss and are used for large installations networking numerous ADM monitoring channels, or where multichannel processing is desired. The 16 bit ADM units can process data from up to three detectors simultaneously with display provisions for each detector. Up to 500 16 bit ADM units can be networked together in a LAN configuration. Along with the standard features common to all ADM series units, the 16 bit ADM also includes a second RS-485 serial communications port for redundant bi-directional LAN communication, a large area bit mapped addressable display, and enhanced diagnostics.

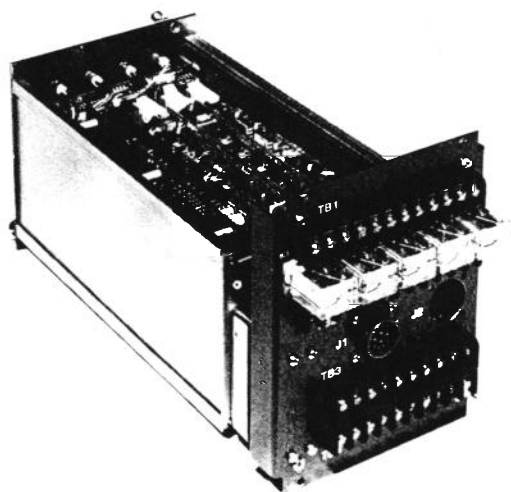

**ENVIRONMENT:**

Temperature: -10°C to +60°C (10°F to 140°F).  
 Humidity: 95% RH non-condensing  
 Pressure: Atmospheric.

**OUTPUTS:**

RS-232, RS-485, 0-10 Volt DC, 4-20 mA DC,  
 DPDT 5 Amp resistive.  
 115 V rated relay contacts for FAIL, ALERT and  
 HIGH alarms.

**POWER:**

115 Volt 50/60 cycle std., 8 watt.  
 220 Volt 50/60 cycle, 24 volts dc.

**MEMORY:**

Up to thirty (30) each of the following historical  
 count rates are maintained in battery backed up  
 memory:

- One minute
- One hour
- Ten minutes
- One day

**SYSTEM BLOCK DIAGRAM**

(THE ADM SYSTEM IS CAPABLE OF OPERATING  
 WITH MANY FORMS OF COMMUNICATION LINES)

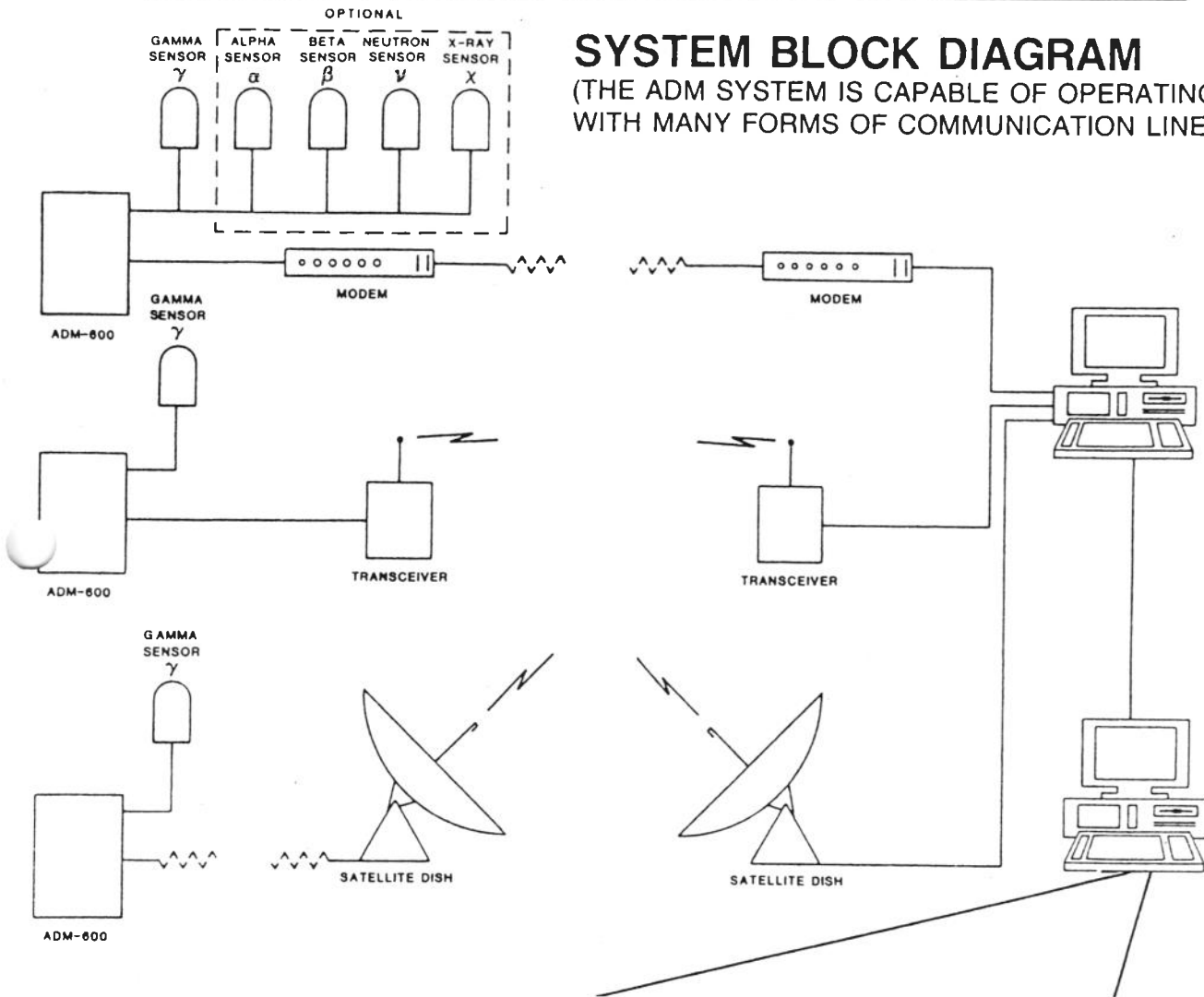

UNIT	1	2	3	4	5	6	7	8
NAME	1100A	1100B	1100C	1100D	1100E	1100F	1100G	1100H
DOSE	1100A	1100B	1100C	1100D	1100E	1100F	1100G	1100H
UNIT	9	10	11	12	13	14	15	16
DATE								
TIME								
UNIT	LOCATION		UNIT		LOCATION			
1	STACK		9					
2	REACTOR 1		10					
3	FUEL BLDG		11					
4	TURBINE BLDG		12					
5	COOLING TOWER		13		UNASSIGNED			
6	REACTOR 2		14					
7	CONTROL ROOM		15					
8	RAD WASTE		16					
9	RAD WASTE		17					

DATE OF Jan 1991 TIME 01:03:18

MULTI-CHANNEL SYSTEM DISPLAY

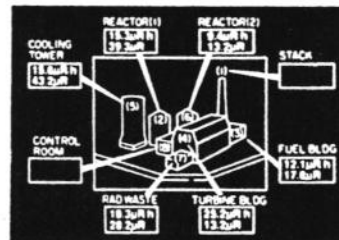

NUCLEAR PLANT

For additional information please contact:

**NUCLEAR RESEARCH CORPORATION**  
 125 TITUS AVENUE, P.O. BOX H, WARRINGTON, PA 18976  
 Phone: (215) 343-5900 / Fax: (215) 343-4670

**NUCLEAR RESEARCH CORPORATION**  
 58 RICHBOYNTON ROAD, DOVER, NJ 07801  
 Phone: (201) 361-5600 / Fax: (201) 361-9506

**SAFETY EVALUATION DETERMINATION  
for  
POWER DETECTOR MECHANICAL HEIGHT ADJUSTERS**

PURPOSE and SCOPE

This safety evaluation is for installation and routine use of mechanical height adjusters for the ex-core reactor power detectors. The evaluation reviews the effects and potential effects on the design bases of the reactor as a result of the installation and routine use of these components.

Introduction

The UMLRR makes use of three compensated ion chamber (CIC) detectors for measuring core neutron flux levels. Located in three of four corner posts of the reactor suspension frame, the detectors are wired to electronic amplifiers. Two amplifiers measure reactor flux levels on a linear scale. The third amplifier monitors the rate of flux change to provide the reactor period in seconds and also provides a measure of reactor flux on a logarithmic scale. All three flux-monitoring channels are calibrated in terms of reactor thermal power level using a calorimetric heat balance method.

Current Calibration System

The three CIC detectors are mounted inside three of the four reactor support structure corner-posts. The CICs measure neutron flux and are calibrated in terms of thermal heat generation in watts. The signal, high voltage, and compensating voltage cabling for each detector ascends the hollow corner post, from the detector positioned near the core, to the reactor bridge above the reactor pool. The cabling passes through a hole in the top plate of the corner-post and is then routed to the reactor control room. Positioning of the detectors is currently maintained by means of a threaded compression fitting located on the cable. The compression fitting threads to a mated sleeve located on the corner-post top plate.

The UMLRR Technical Specifications require that a power calibration of the detectors be performed annually. A calorimetric method is employed to assure that reactor power level monitors indicate the true thermal power level. If a CIC flux monitor output does not match the power level determined by calorimetric means, the CIC detector is re-positioned in or out of the reactor neutron flux to obtain a matched reading. This is currently accomplished by loosening the compression fitting and moving the CIC cable up or down.

Proposed Calibration System

To calibrate and adjust the reactor thermal power detectors, a precision, rack and pinion, linear slide will be mounted to allow accurate positioning and adjustment of the

reactor power detectors within the core. The adjusters are equipped with 12" scale having 1/100" gradations for precise adjustments. The detector cable will be clamped onto a slide-carriage that moves along the rack by means of a thumb-screw attached to a pinion gear. A set-screw locks the carriage in place on the rack.

The adjusters are to be used to calibrate the in-core power detectors using a calorimetric to determine the reactor true power level. For extended operations at full power, the adjusters may be used to re-calibrate the power detectors to match the true power level determined by a calorimetric measurement. This will have the result of adjusting the in-core detectors out of the core to compensate for the neutron flux shifting that results from fission product build-up and from temperature increases. Administrative controls will be implemented to assure the detectors are returned to the correct position relative to a cold, clean core.

The following safety evaluation demonstrates that an unreviewed safety question does not exist for replacing the compression fitting with a precision mechanical adjuster and for using the adjusters to calibrate the reactor power monitors under clean core conditions and poisoned core conditions during extended operations.

## SAFETY EVALUATION

### Introduction

Changes to facility design, as it is described in the FSAR, are allowed under regulation 10CFR50.59 without review by the NRC, provided the Technical Specifications are not changed, and that it is demonstrated that the modification will not involve an Unreviewed Safety Question (USQ). The process provides assurance that the plant licensing and design bases are not degraded. A USQ is defined in 50.59(a)(2) as follows:

"A proposed change, test or experiment shall be deemed to involve an unreviewed safety question (i) if the probability of occurrence or the consequences of an accident or malfunction of equipment important to safety previously evaluated in the safety analysis report may be increased; or (ii) if a possibility for an accident or malfunction of a different type than any evaluated previously in the safety analysis report may be created; or (iii) if the margin of safety, as defined in the basis for any technical specification, is reduced.

The evaluation should demonstrate that:

- A. There is no increase in the probability of occurrence of an accident previously evaluated in the SAR.
- B. There is no increase in the consequences of an accident previously evaluated in the SAR.

- C. There is no increase in the probability of occurrence of a malfunction of equipment important to safety previously evaluated in the SAR.
- D. There is no increase in the consequences of a malfunction of equipment important to safety previously evaluated in the SAR.
- E.
- F. The possibility of an accident of a different type than any previously evaluated in the SAR is not created.
- G. The possibility of a different type of malfunction of equipment important to the safety than any previously evaluated in the SAR is not created.
- H. The margin of safety as defined in the basis for any technical specification is not reduced.

#### TECHNICAL SPECIFICATIONS EFFECT

The Technical Specifications of the UMLRR do not describe the method or means for calibrating the neutron measuring reactor power detectors. Technical Specification 4.2.3 states the neutron flux measuring channels will be calibrated to reactor thermal power. Subsequently, the installation and use of precision power detector adjusters will not require a change to the technical specifications.

#### UNREVIEWED SAFETY QUESTION DETERMINATION:

The Safety Evaluation Report (SER) issued by the Nuclear Regulatory Commission in 1985 evaluated four postulated accident scenarios for the UMLRR. The SER postulated accident scenarios analyzed were: (1) Failure of a Fueled Experiment, (2) Rapid Insertion of Reactivity, (3) Loss of Coolant, (4) Fuel Handling Accident. The Failure of a Fueled Experiment is considered the maximum hypothetical accident (MHA). The SER goes on to state "None of the reactor transients or other accidents analyzed posed a significant risk of fuel cladding failure and would not result in a release of radioactivity."

Of the scenarios analyzed in the SER, none are directly affected by the installation and use of the mechanical power detector adjusters. Nonetheless it is prudent to analyze the potential effects of this facility change to the reactor safety system.



## EVALUATION

- A: Will operation of the reactor with the mechanical height adjusters increase the probability of an accident previously evaluated in the SAR?

No.

The new mechanical adjusters are used similar to the old compression fittings. Additionally, the new system allows more accurate and precise adjustment. The routine use of these devices will not increase the probability of an accident.

- B: Will the operation of the reactor with the mechanical height adjusters increase the consequences of an accident previously evaluated in the SAR?

No.

The implementation of adequate procedural controls, along with the availability of more accurate and precise detector positioning, will assure operation of the reactor with the mechanical height adjusters will not increase any consequence of accidents previously analyzed.

- C: Will the operation of the reactor with the mechanical height adjusters increase the probability that a piece of equipment important to nuclear safety will malfunction?

No.

The mechanical adjusters are directly coupled to equipment important to nuclear safety and their use does affect the accurate read-out of the equipment. However, the use of adequate procedural controls, along with the availability of more accurate and precise detector positioning, will assure operation of the reactor with the mechanical height adjusters will not increase the probability that a piece of equipment important to nuclear safety will malfunction

- D: Will the operation of the reactor with the mechanical height adjusters increase the consequence of a malfunction of equipment important to nuclear safety?

No.

The use of adequate procedural controls, along with the availability of more accurate and precise detector positioning, will assure operation of the reactor with the mechanical height adjusters will not increase in the consequence of a malfunction of equipment important to nuclear safety.

E: Will the operation of the reactor with the mechanical height adjusters create the possibility of an accident of a different type than evaluated in the FSAR?

No.

All credible accident scenarios have been evaluated in the UMLRR SER. Any accident scenario involving the use of mechanical height adjusters would be within the envelope of accidents evaluated in the SER and analyzed in the FSAR.

F: Will the operation of the reactor with the mechanical height adjusters create the possibility of an equipment malfunction not previously analyzed in the FSAR?

No.

The credible accident scenarios also bound equipment malfunction and have been evaluated in the SER and analyzed in the FSAR.

G: Will the operation of the reactor with the mechanical height adjusters reduce the margin of safety defined in the basis of any Technical Specification?

No.

The use of adequate procedural controls, along with the availability of more accurate and precise detector positioning will assure operation of the reactor with the mechanical height adjusters will be within the bases of the applicable Technical Specifications. Subsequently, there will not be any affect any safety margin defined in the Technical Specifications.

#### DETERMINATION:

The operation of the reactor with the mechanical height adjusters does not involve a modification of Technical Specifications or an unreviewed safety question. As such, it may be implemented without prior NRC approval in accordance with 10 CFR 50.59.



For Stock Nos. 61,284, 31,240, 61,285, 31,241, & 61,286

Technical Service (609) 573-6259  
Tech Help Fax Line (609) 573-6233

## LINEAR SLIDE COMPONENTS FOR RACK AND PINION SLIDES

The items described here are supplied separately for maximum user convenience. Together they are used for precise linear positioning of cameras, microscopes, lasers, etc. A selection of tracks with or without scales and carriages with or without indicators may be assembled in numerous ways to create a positioning system that will satisfy many requirements. The basic system consists of a single carriage assembled to either the 12 inch track or to the 24 inch track. These instructions pertain to the assembly and adjustment of the basic system.

The track is a black anodized aluminum alloy extrusion with a dovetail-shaped cross section. A brass helical rack runs the full length of the track, with or without a scale. The 12 inch track with scale is marked with  $\frac{1}{100}$  inch and  $\frac{1}{10}$  inch graduations. Four counterbored holes are provided for fastening the track to a bench or to other equipment. The carriage (platform) is also a black anodized aluminum alloy extrusion, with or without an indicator. Its dovetail shaped cross section matches that of the track. An adjustable brass gib is used to take up clearance to give smooth operation with a minimum of side shake. A steel helical pinion is coupled to the one inch diameter knob and meshes with the brass rack on the track. Fine positioning of the carriage along the track is done by turning this knob. One revolution of the knob will move the carriage 18mm. The  $\frac{1}{2}$  inch diameter thumb screw is used to lock the carriage in any position. A  $\frac{1}{4}$  inch diameter hole is provided on the top surface for mounting other equipment or components.

Figure 1.

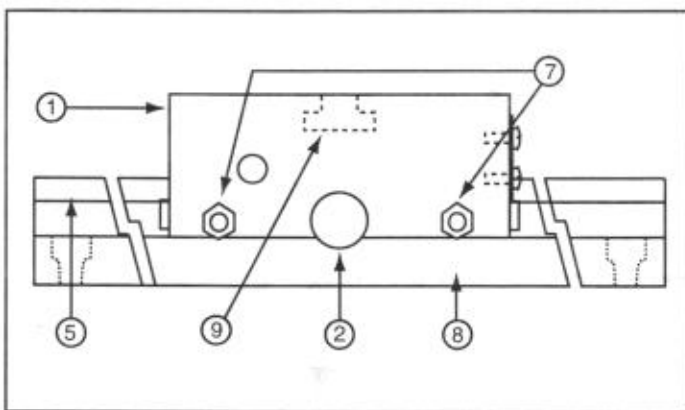

### CONTENTS

Use the following list for identification of parts in Figures 1, 2, & 3:

1. Carriage
2. Lock Knob

3. Adjustable Brass Gib
4. Control Knob
5. Brass Rack
6. Steel Helical Pinion
7. Adjusting Screw, Locknut, & Lock Washer
8. Track
9.  $\frac{1}{4}$ " Mounting Hole for Components
10.  $\frac{5}{32}$ " Holes for Mounting Track Linear Side
11. Rack Mounting Screws
12. Indicator
13. Scale  $\frac{1}{10}$ ",  $\frac{1}{100}$ " Grad.

### SPECIFICATIONS

- Dimensions:** 12"L (or 24") x 2- $\frac{1}{4}$ "W x  $\frac{3}{4}$ "H  
**Platform Travel:** 10" max.  
**Platform Size:** 4"L x 2- $\frac{1}{4}$ "W x 1- $\frac{3}{8}$ "H  
**Load Capacity:** (H): 15 lbs. (V): 5 lbs. unlocked, 15 lbs. locked  
**Scale:** 12"L  
**Graduations:** 0.10"  
**Linearity:** 1% nominal  
**Material:** Extruded Aluminum

Figure 2.

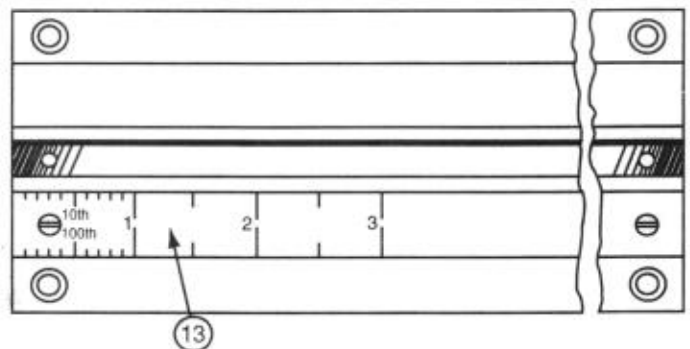
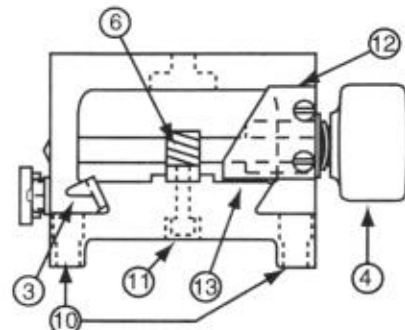

Figure 3.



## ASSEMBLY

The following steps will enable you to easily assemble the linear slide components and get the system ready for use. Once the system is assembled follow the additional instructions to make sure the gib is adjusted for optimum use.

### 1. ASSEMBLY OF LINEAR COMPONENTS

- A. Remove one of the screws (11) that hold the rack to the track.
- B. Unscrew the two gib adjusting screws (7) (then loosen lock nuts) and the carriage lock knob (2) until the tips of the screws are below the inner dovetail surface.
- C. Place the gib (3) in position on the carriage (1) on the inner dovetail surface with the tabs on the end of the gib oriented as shown in Figure 3.
- D. Hold the gib in position, line up the carriage dovetail with the track dovetail, and slide the carriage onto the track.

Note - the carriage may be positioned with the control knob on either side of the track.

- E. Continue pushing the carriage along the track until the pinion engages the rack (5). Turn the control knob (4) to move the carriage further along the track. While doing

- this, be sure the rack does not come out of its groove.
- F. Replace and tighten rack mounting screw (11).
- G. Adjust gib as described in the next section.
- H. Apply a thin film of non-staining grease to the length of the track.

### ADJUSTMENT OF THE GIB

- A. Make sure the gib is completely down against the track. Check for correct orientation of the tabs on the end of the gib.
- B. Tighten both gib adjusting screws enough to clamp it against the track. Be sure the lock nuts are completely loosened so that they do not interfere with turning the screws.
- C. Tighten each nut just enough to start compressing the lockwasher.
- D. "Back off" each screw ¼ turn.
- E. Tighten each lock nut securely while preventing the screw from turning.
- F. Check for ease of operation by moving the carriage back and forth using the control knob. Be sure the lock screw is loosened. If the motion is too stiff, "back off" the adjusting screws. If it is too loose, tighten the screws slightly.

SAFETY EVALUATION DETERMINATION  
for  
UPGRADE OF UMLRR AREA RADIATION MONITORING SYSTEM

The safety evaluation reviews the effects and potential effects on the design bases of the reactor as a result of upgrading the University of Massachusetts Lowell Research Reactor (UMLRR) Area Radiation Monitoring System.

The UMLRR systems and components affected by this change are described in the following attached UMLRR FSAR descriptions and Technical Specifications:

- 3.4.2.1 (Ventilation) System Closure
- 4.4.19 ULR Radiation Monitoring Cabinet
- 8.1.4 Area Monitoring
- Appendix 10 – Reactor Area Radiation Monitoring System and Emergency Alarm System
- Technical Specifications LCO) 3.4 Radiation Monitoring Equipment and 4.3 (Surveillances) Radiation Monitoring Equipment

Area Radiation Monitoring System Description

The Area Radiation Monitoring System (ARMS) is intended to provide information on radiological conditions for both routine operations and possible emergency situations associated with the reactor. The ARMS consists of multiple and various radiation detectors as described in the FSAR Chapter 10-Appendix, and includes a cabinet in the control room that houses the remote readout indicators for the detectors and alarm indicators. The technical specification limiting condition of operation for radiation monitoring system (TS 3.4) specifies the minimum required radiation monitors being a gaseous and particulate stack monitor, a constant air monitor, and one area monitor over the reactor pool and one area monitor on the experimental level. The ARMS as described in the FSAR consists of 19 individual radiation monitors to provide more than adequate redundancy for area radiation monitoring.

As described in the FSAR, elevated radiation levels at various monitoring locations above the trip set-point will trigger indicators for either a Potential Limited Radiation Emergency Alarm (P-LREA) or a Potential General Radiation Emergency Alarm (P-GREA). A P-LREA would be indicative of localized radiation hazard within the containment building. The P-GREA would be indicative of a more wide spread hazard with the potential for a release of radioactivity outside of the containment building. Various detector combinations have been assigned to be associated with either the P-LREA or the P-GREA (see Chapter 10, Appendix). The indicators on the cabinet include an alarm indicator light for either alarm condition and an audible signal. Upon indication of unusual or unexpected radiation levels, the operator will implement the steps outlined in the Radiation Emergency Procedure. Pushbuttons on the cabinet labeled as GREA and LREA are available for the operator to initiate the LREA or GREA as

appropriate (see FSAR 4.4.19). Actuation of the LREA or GREA pushbuttons by the operator will scram the reactor (FSAR 4.4.19) and initiate ventilation closure (FSAR 3.4.2.1). As noted in the FSAR, the operator may initiate the LREA or GREA whether or not the specific combination of detectors indicates either of the potential alarm conditions.

### System Upgrade Description

The original radiation detectors and cabinet remote readout modules were manufactured by Tracerlab and installed prior to the first reactor operation in 1974. The system of relay logic for initiating the P-LREA and P-GREA, ventilation closure, and reactor scram, as well as the visual and audible alarm indicators, was designed, built, and installed by the reactor operations staff in the early 1970s. The radiation detectors and the remote readout modules are now over 26 years old and are experiencing more frequent failures. The new detectors and new readout modules for this upgrade were designed and built by Nuclear Research Corporation (NRC). A 50.59 safety evaluation for these instruments was originally done in 1997, although no changes were implemented at that time.

In addition to upgrading the detectors and readouts, the cabinet that houses the readout indicators will be replaced. This cabinet includes the "in-house" designed and built relay logic trees connected to the readout modules that in certain combinations initiate visible and audible alarms indicating the potential for either an LREA or GREA. The new cabinet includes analog and digital input and output (I/O) modules, a processor, and software to recreate the relay logic used to annunciate the P-LREA and P-GREA conditions. The relays for ventilation closure and reactor scram will remain unchanged. The NRC remote readout modules will display the detector readings and provide low alarm and high alarm indicator lights similar to the Tracerlab units (refer to 1997 Safety Evaluation). In addition, the NRC detector readouts will be repeated on a PC display located above the modules and also located remotely by the first floor airlock.

The new cabinet has been designed, built, and installed by Artisan Industries, Waltham, MA. All documentation associated with the original ARMS and the new NRC modules and detectors in addition to FSAR Ch.10-Appendix descriptions was provided to the contractor. Various meetings were held to go over the requirements and system design. The new cabinet integrates the NRC remote modules, the digital I/O modules, and the power supplies for the system. The contractor provided the system programming to reproduce the relay logic used in the original ARMS and for the remote displays. The industrial control hardware and software used by the contractor was manufactured by OPTO22, Inc.

The new system has been designed to maintain the same capability as the original system. The major differences are the digital processing of signals from the readout modules and the use of software-based logic to replace the system of relay logic that initiates the potential LREA and potential GREA alarms. The operator will still manually initiate either the LREA or GREA via a pushbutton on the panel. However, a new feature to be added is the automatic ventilation closure for the P-GREA. This feature is desirable as it will preclude operator action for the P-GREA. This new addition will in no way affect

the other methods of ventilation closure described in FSAR 3.4.2.1, including operator initiation of either of the LREA or GREA, whether or not the specific combination of detectors indicates either of the potential alarm conditions exists.

A summary of the system actions, both automatic and manual are presented on the next page. Existing and new features are noted in parentheses.

#### System Actions:

High readings on detectors associated with LREA logic initiate the following actions:

1. P-LREA indicator on cabinet activated. (no change)
2. P-LREA indicator on display screen activated. (new addition)
3. "Squee" alarms in the reactor building and laboratory building. (no change)

Pressing the ALARM pushbutton on the cabinet declares a local radiation emergency and initiates the following additional actions:

4. LREA indicator on display screen activated. (new)
5. Evacuation alarm horns in reactor building only. (no change)
6. Reactor building ventilation closure. (no change)
7. Reactor SCRAM. (no change)

High readings on detectors associated with GREA logic initiate the following actions:

1. P-GREA indicator on cabinet activated. (no change)
2. P-GREA indicator on display screen activated. (new)
3. "Squee" alarms in reactor building and laboratory building. (no change)
4. Reactor building ventilation closure. (new)

Pressing the ALARM pushbutton on the cabinet declares a general radiation emergency and initiates the following additional actions:

5. GREA indicator on display screen. (new)
6. Evacuation alarm horns in reactor building and laboratory building. (no change)
7. Reactor SCRAM. (no change)

#### ARMS QUALITY ASSURANCE

The new detectors and modules have been tested and calibrated according to the manufacturer's instructions. The remote displays have been shown to match the module readouts. The software logic that replaced the original relay logic for annunciating the P-LREA and P-GREA has been tested by tripping each detector with the calibration source and verifying each combination of detectors as listed in the FSAR Chapter 10-Appendix initiates the designated alarm. In addition, the system actions as noted above were verified to be operable. Very minor descriptive updates to the FSAR will be made. The major differences are the digital processing of signals from the readout modules and the use of software-based logic to replace the system of relay logic that initiates the potential LREA and potential GREA alarms. Procedures affected by this change are SP-1 Calibration of the Radiation Monitoring System and RO-13 Radiation Monitoring System Checkout. In addition to this internal review and documentation required by 10CFR 50.59, all procedure changes will be reviewed by the RSSC as appropriate before normal operations resume.

## SAFETY EVALUATION

### INTRODUCTION

Changes to facility design, as it is described in the final safety analysis report (FSAR) are allowed under regulation 10CFR50.59 without review by the NRC, provided the Technical Specifications are not changed, and that the criteria outlined below are met.

The evaluation should demonstrate that the change will not:

- (1) Result in more than a minimal increase in the frequency of occurrence of an accident previously evaluated in the FSAR;
- (2) Result in more than a minimal increase in the likelihood of occurrence of a malfunction of a structure, system, or component (SSC) important to safety previously evaluated in the FSAR;
- (3) Result in more than a minimal increase in the consequences of an accident previously evaluated in the FSAR;
- (4) Result in more than a minimal increase in the consequences of a malfunction of an SSC important to safety previously evaluated in the FSAR;
- (5) Create a possibility for an accident of a different type than any previously evaluated in the FSAR;
- (6) Create a possibility for a malfunction of an SSC important to safety with a different result than any previously evaluated in the FSAR;
- (7) Result in a design basis limit for a fission product barrier as described in the FSAR being exceeded or altered; or
- (8) Result in a departure from a method of evaluation described in the FSAR used in establishing the design bases or in the safety analyses.

### TECHNICAL SPECIFICATIONS EFFECT

The LCO and Surveillance Technical Specifications (as indicated above) will not require any changes. Although the manufacturer recommended detector calibration is annually, the current specification of semi-annual will remain unchanged. Subsequently, no technical specification change is required for this modification.



## SAFETY DETERMINATION:

The postulated accident scenarios evaluated in the UMLRR FSAR include: Loss of Coolant Flow; Loss of Coolant (considered the design basis accident); Refueling Accident; Step and Continuous Reactivity Increase; and External Events. **The analyses conclude that none these reactor transients or other accidents evaluated would result in fuel cladding and subsequent release of radioactivity.** In addition, a maximum hypothetical accident (MHA) involving the release of fission products from one fuel plate is also analyzed to determine the hypothetical radiological consequences. The MHA is not a credible accident and has no initiating event.

Of the accident scenarios analyzed in the FSAR, only the MHA may be considered as affected by the changes to the Area Radiation Monitoring System (ARMS). Though the MHA is not a credible accident and has no initiating even, the MHA analysis assumes fuel clad failure on one fuel plate and assumes containment isolation and a leakage rate of 10%/day (FSAR 9.2.1). For this 50.59 evaluation, the FSAR MHA is considered.

## 10 CFR 50.59 EVALUATION CHECKLIST

- 1: Will the ARM system upgrade result in more than a minimal increase in the frequency of occurrence of an accident previously evaluated in the FSAR?

No.

The frequency of occurrence of accidents is not analyzed in the FSAR and probabilistic risk assessments (PRA) are not required for non-power reactors. Of the accident scenarios analyzed in the FSAR, only the MHA may be considered as affected by the changes to the ARMS. The MHA is a postulated event with no initiating cause and no expectance of occurrence. The frequency of occurrence as applies to this criterion would not be affected.

- 2: Will the ARM system upgrade result in more than a minimal increase in the likelihood of occurrence of a malfunction of a structure, system, or component (SSC) important to safety previously evaluated in the FSAR?

No.

The likelihood of occurrence of SSC malfunctions is not evaluated in the FSAR. Since probability risk assessments are not performed, there is no reliability data available on SSCs to adequately determine the probability of occurrence of malfunctions. The ARMS is not part of the reactor safety system (RSS) SSCs, although it does have a dry contact relay in series with the safety chain of scram relays. The purpose of the ARMS scram is to mitigate a possible radiological release from the reactor and so as such could be considered a system important to safety. For a qualitative comparison, the 26-yr old original ARMS detectors and modules were experiencing more frequent failures, thereby reducing the redundancy factor that exceeds the ARM LCO requirements. The new ARM system uses new detectors and modules which will improve reliability compared to

the current aging components. The new instrumentation has been thoroughly calibrated and tested for functionality. The system of hardware and software that replaces the "in-house" built system of relay logic and indicators used for the P-LREA and P-GREA alarm indications has been functionally tested using the appropriate UMLRR test and calibration procedure. Given age related issues, the reliability of the new components is will be better than the original equipment. In terms of the MHA, the initiation of ventilation closure continues to be performed manually (with the exception of the new P-GREA capability). The ventilation system uses fail-safe blast valves (FSAR 3.2). System closure can be manually initiated by the operator in multiple ways (FSAR 3.4.2.1).

- 3: Will the ARM system upgrade result in more than a minimal increase in the consequences of an accident previously evaluated in the FSAR?

No.

Of the accident scenarios analyzed in the FSAR, none are affected by the upgrade with the possible exception of the MHA. The MHA assumes ventilation system closure and a 10% volume leakage per day. The upgrade will not affect the ability to initiate ventilation system closure. Therefore, the consequence of the MHA analysis is not affected.

- 4: Will the ARM system upgrade result in more than a minimal increase in the consequences of a malfunction of an SSC important to safety previously evaluated in the FSAR?

No.

Malfunctions of SSC resulting in a radiological consequence are not analyzed in the FSAR. Qualitatively, a malfunction of the ARMS could lead to a radiological consequence if the operator or other personnel are not alerted to increasing radiological conditions. However, this consequence would be the same given a malfunction in either the original system or the new system.

- 5: Will the ARM system upgrade create a possibility for an accident of a different type than any previously evaluated in the FSAR?

No.

All credible accident scenarios have been evaluated in the UMLRR FSAR. There are no credible accidents associated with the ARM system that would not be bounded by the accident scenarios in FSAR, including the MHA.

- 6: Will the ARM system upgrade create a possibility for a malfunction of an SSC important to safety with a different result than any previously evaluated in the FSAR?

No.

The results of some equipment malfunctions (e.g., loss of primary pump) have been evaluated in the FSAR, though none were analyzed for the ARM system. Nonetheless, the possible results of any instrument and controls failure using the old equipment would be the same for the new equipment.

- 7: Will the ARM system upgrade result in a design basis limit for a fission product barrier as described in the FSAR being exceeded or altered?

No.

As analyzed in the FSAR, there are no reactor transients or credible accidents that pose a significant risk of fuel cladding failure. The UMLRR design basis limit for the primary fission product barrier (fuel cladding) is the onset of nucleate boiling (ONB). The temperature for ONB is well below that for fuel cladding failure and the UMLRR Technical Specifications limiting safety system settings (LSSS) assure that the ONB is not reached. The ARM system does not affect neutronics or thermal hydraulics variables used in establishing the LSSS.

- 8: Will the ARM system upgrade result in a departure from a method of evaluation described in the FSAR used in establishing the design bases or in the safety analyses?

No.

Since the ARM system does not affect neutronics or thermal hydraulics variables, the methods of evaluation described in the FSAR used in establishing the design bases or in the safety analyses are unaffected.

#### DETERMINATION CONCLUSION:

The ARM system upgrade does not involve a modification of the Technical Specifications and meets the criteria specified in 10 CFR 50.59. As such, it may be implemented without prior NRC approval in accordance with 10 CFR 50.59.

SAFETY EVALUATION DETERMINATION  
for  
UPGRADE OF UMLRR PROCESS CONTROL CABINET

The safety evaluation reviews the effects and potential effects on the design bases of the reactor as a result of upgrading the University of Massachusetts Lowell Research Reactor (UMLRR) process control cabinet (PCC) to a new process control system (PCS).

The UMLRR systems and components affected by this change are described in the UMLRR FSAR:

- 3.4 (Ventilation) System Operation
- 4.4.1-4 Control and Instrumentation
- 4.4.15 Scram Circuits
- 4.4.17 Process Control and Instrumentation

Process Control Cabinet Description

The UMLRR process control cabinet (PCC) serves as the control room assembly point for the location of the ventilation valve position indicators, core flow indicator, temperature recorder, flow recorder, conductivity recorder, fourteen motor pushbutton indicating controls, instrument power supply, and circuit breakers. One circuit breaker controls the instrument power to the process control cabinet and the other circuit breaker controls power to the pneumatic tube system.

Manual control of reactor cooling systems, water conditioning systems, containment building ventilation system, and the monitoring of these systems is accomplished via the PCC. Each of a number of process motors is controlled by a set of remote RUN and STOP indicating pushbuttons on the PCC panel. These motors include the primary and secondary pumps, secondary cooling tower fans, all ventilation exhaust fans, the makeup pump and the cleanup pump. The PCC also houses the chart recorders for the primary and secondary system flow rates, three primary system temperature measurements, and three water conductivity measurements.

The PCC was installed prior to the first critical operation 1974. Age-related component failures in this panel have forced various "work-arounds" to permit continued reactor operations. Almost all the light indicators on the process motor push buttons have failed. The light indicator is integral with the pushbutton, forming a single unit which requires replacement of the entire assembly. While each pushbutton is operational, the loss of indication results in diminished information to the operator. For example, confirmation that the primary pump is running can only be made by observing the flow on the chart recorder or on the core flow meter. Problems with chart recorders are also prevalent. These include increased maintenance and reliability issues for worn and binding mechanical components, and problems associated with increasingly obsolete chart paper and pens. Light indicators on the ventilation valve position status panel routinely burn

out resulting in diminished information to the operator. The bulbs also are unique and expensive to replace.

### Process Control System Description

The Process Control System (PCS) uses control and input/output hardware manufactured by Opto 22, Inc. for process control, process monitoring, and data acquisition. The system software also is produced by Opto 22. The software is an integrated suite of industrial control and automation software. While designed primarily for manufacturing applications, the hardware and software easily adapt to any function. The Opto 22 hardware is Factory Mutual certified, meeting rigorous safety standards. This is the same hardware and software associated with the Area Radiation Monitoring system upgrade in 2000.

The PCS hardware will consist of three main enclosures (one for various power supplies and two for input/output modules), two personal computers, and one Ethernet switch. The Power Supply enclosure contains AC and DC power breakers for the control system, a 5VDC power supply, 12 VDC power supply, and a 24 VDC power supply. The modules enclosures hold the main system controller and the three input/output (I/O) module boards.

A series of terminal block strips are used to connect the various field devices (motor controllers, flow sensors, temperature indicators, etc.) to the digital and analog I/O modules attached to the boards. Digital I/O modules handle field devices that can be in only one of two states: either on or off (e.g., motor control, valve position, etc.). Analog I/O modules handle devices that have a range of possible values (e.g., temperature, flow, etc.). The I/O modules translate signals from field devices—such as switches and sensors – into a digital format understandable by the processor, and translate processor signals into forms the field devices can understand. Each module employs optical isolation to maintain a protective barrier between the processor and the field devices.

The I/O modules communicate data to a processor on the board. The processor then communicates the data to the main controller. In addition to communication, the board processors are capable of providing independent local control of output modules to perform simple tasks such as on/off control. The main controller receives and processes the input from each board processor. The controller maintains a programmed set of instructions to perform control actions by sending commands to the board processors. The controller also relays data to the HMI personal computers. The HMI computers display the information received from the controller and provide a touch screen and a keyboard terminal for manual control of process functions.

Two redundant personal computers connect to the controller via an Ethernet switch to provide a human machine interface (HMI). Each computer has a flat panel, touch-screen display. Various programmed configurations provide graphical displays for data from the controller and the transfer of operator commands. Data trending and archiving are also accomplished. The computers are independent and may display the same or different

process information, depending on the operator's choice. Each computer has a redundant copy of the interface program developed for the PCS.

All software programming is done using Opto 22's suite of software. The suite's Opto Control development software was used for the controller programming and the suite's Opto Display development software was used for HMI displays. The configuration of the PCS hardware and software was done by the Martindale Associates engineering firm, using system descriptions in the FSAR and working in close cooperation with UML Reactor staff. The HMI displays graphics are designed to closely match the look of the PCC pushbuttons and indicators as much as possible.

The following provides a summary of the field devices connected to the PCS:

Digital Input Items

Main intake ventilation fan on/off status  
Main exhaust ventilation fan on/off status  
Other ventilation fans on/off status  
Ventilation valves open/closed status  
Access doors open/closed status  
Pumps on/off status

Digital Output Items

Main exhaust fan on/off  
Other ventilation fans on/off  
Pump motors on/off  
Cooling towers on/off

Analog Input Items

Reactor power measuring channels  
Primary coolant flow  
Core coolant flow  
Pool height  
Secondary coolant flow  
Primary coolant temperatures  
Secondary coolant temperatures  
Water conductivity and pH  
Containment differential pressure

Figures 1 and 2 attached provide block diagrams showing the devices associated with reactor safety system (RSS) process variables (reactor power, coolant flow, coolant temperature, and pool height) attached to the PCS. The analog inputs to the PCS are attached to auxiliary analog output points from the devices and are optically isolated. For pool height, in addition to the existing float switch, a new ultrasonic sensor has been added to provide a reading of the actual pool height. As shown in the block diagrams, the PCS does not replace any functionality, but it does provide additional diversity and redundancy to the RSS. The PCS also includes a dry contact relay connected to the scram chain. If communication between the boards, controller, or displays is lost, the relay will open and scram the reactor.

The new system has been designed to maintain the same capability as the original system and will not require changes to the reactor NRC license technical specifications. Descriptive updates to the reactor FSAR will be made. The major differences will be the use of an HMI display for monitoring and controlling certain functions as opposed to hard-wired indicators and controls.

#### PCS QUALITY ASSURANCE TESTING

The system has been thoroughly tested and calibrated using existing procedures. Some procedures, such as pre-critical check-out will be changed to reflect the new system. In addition to the internal review and documentation required by 10CFR 50.59, all procedure changes will be reviewed by the RSSC as appropriate before normal operations resume.

During various phases of the PCS installation, functional testing of the hardware and software was performed. The following procedures were performed to assure the new system and the all affected reactor safety and non-reactor safety system channels operate in the fashion described by the FSAR and meet technical specification requirements:

- SP-2 Containment Valve Closure Initiation and Time
- SP-4 Emergency Exhaust System Checkout
- SP-10-Appendix 3 Calibration of Conductivity Instrumentation
- SP-12 Calibration of Temperature Monitoring Devices
- CP-1 Calibration of RTD Temperature Channels
- SP-13 Calibration of Flow Measuring Devices and dP Measuring Devices
- SP-14 Calibration of Float Actuated Devices
- SP-16 Rod Drop Measurements
- SP-23 Scram Function Test
- RO-9 Reactor Checkout

In addition, a calorimetric calibration of all power measuring instruments was performed. All instrument responses meet the technical specification requirements and data from these calibrations and tests are on file.

## PCS SAFETY EVALUATION

### INTRODUCTION

Changes to facility design, as it is described in the final safety analysis report (FSAR) are allowed under regulation 10CFR50.59 without review by the NRC, provided the Technical Specifications are not changed, and that the criteria outlined below are met.

The evaluation should demonstrate that the change will not:

- (1) Result in more than a minimal increase in the frequency of occurrence of an accident previously evaluated in the FSAR;
- (2) Result in more than a minimal increase in the likelihood of occurrence of a malfunction of a structure, system, or component (SSC) important to safety previously evaluated in the FSAR;
- (3) Result in more than a minimal increase in the consequences of an accident previously evaluated in the FSAR;
- (4) Result in more than a minimal increase in the consequences of a malfunction of an SSC important to safety previously evaluated in the FSAR;
- (5) Create a possibility for an accident of a different type than any previously evaluated in the FSAR;
- (6) Create a possibility for a malfunction of an SSC important to safety with a different result than any previously evaluated in the FSAR;
- (7) Result in a design basis limit for a fission product barrier as described in the FSAR being exceeded or altered; or
- (8) Result in a departure from a method of evaluation described in the FSAR used in establishing the design bases or in the safety analyses.

### TECHNICAL SPECIFICATIONS EFFECT

There are no Technical Specifications affected by the PCS that would require a change. Subsequently, no technical specification change is required for this modification.

### SAFETY DETERMINATION:

The postulated accident scenarios evaluated in the UMLRR FSAR include: Loss of Coolant Flow; Loss of Coolant (considered the design basis accident); Refueling



Accident; Step and Continuous Reactivity Increase; and External Events. **The analyses conclude that none these reactor transients or other accidents evaluated would result in fuel cladding and subsequent release of radioactivity.** In addition, a maximum hypothetical accident (MHA) involving the release of fission products from one fuel plate is also analyzed to determine the hypothetical radiological consequences. The MHA is not a credible accident and has no initiating event.

Of the scenarios analyzed in the FSAR, only Loss of Primary Flow could be considered as affected by changes to the process instrumentation and control system. The Loss of Coolant is not considered, as this would result from either a structural failure (e.g., beam-tube rupture) or by initiating manual methods to drain the pool. The MHA analysis is not affected since the fuel clad failure analysis given in the FSAR does not take credit for the emergency exhaust system.

### 10 CFR 50.59 EVALUATION CHECKLIST

- 1: Will the PCS installation and use result in more than a minimal increase in the frequency of occurrence of an accident previously evaluated in the FSAR?

No.

The frequency of occurrence of accidents is not analyzed in the FSAR and probabilistic risk assessments are not required for non-power reactors. However, a qualitative estimate may be provided for this evaluation. While initiating events are not presented or analyzed in the FSAR, a loss of coolant flow accident (i.e., pump stoppage) may occur from: loss of electrical power, a pump or motor failure, a controls failure (e.g., short circuit), or operator error (i.e., switching off the pump). The first two are unaffected by the change. The probability of a control failure for either hard-wired pushbutton control or the new digital control is impossible to estimate since reliability (PRA) data is not available for either. As noted in the PCC description above, the pushbutton components are nearly 30 years old and problems with the pushbuttons were becoming apparent. The probability of operator error is expected to be less for two reasons: (1) the loss of pushbutton indicators of pump on/off status on the PCC could lead to inadvertent operator error, (2) the digital control for primary pump shutoff on the PCS will have two step process whereby the operator selects the off control then must confirm the off command to shut down the pump.

- 2: Will the PCS installation and use result in more than a minimal increase in the likelihood of occurrence of a malfunction of a structure, system, or component (SSC) important to safety previously evaluated in the FSAR?

No.

The likelihood of occurrence of SSC malfunctions is not evaluated in the FSAR. Since probability risk assessments are not performed, there is no reliability data available on SSCs to adequately determine the probability of occurrence of malfunctions. For a qualitative assessment, the SSC important to safety associated with the PCS are shown in

Figures 1 and 2. As discussed above, these are the channels associated with the process variables of power, coolant temperature, coolant flow, and pool height, all of which are associated with the technical specifications safety limits and limiting safety system settings. These channels and their functionality remain unchanged. Unused or auxiliary analog output points from these devices are attached to the PCS using optically isolated components. The use of these outputs will not increase the likelihood of occurrence of a malfunction of these components. The addition of a dry contact scram relay in series with the scram relay chain (safety chain) does not negatively affect the safety chain. Any single open relay in the series circuit will result in a scram. The addition of another trip point provides additional diversity and redundancy to the reactor safety system. The integration of the PCS hardware and software has been functionally tested using the appropriate UMLRR test procedures as listed above.

- 3: Will the PCS installation and use result in more than a minimal increase in the consequences of an accident previously evaluated in the FSAR?

No.

The FSAR analysis for coolant flow loss shows there is no consequence for the loss of coolant flow with the reactor at full power and reactor scram occurring at 80% the nominal flow rate. The change will have no effect on the consequence or lack thereof.

- 4: Will the PCS installation and use result in more than a minimal increase in the consequences of a malfunction of an SSC important to safety previously evaluated in the FSAR?

No.

Malfunctions of SSC resulting in a radiological consequence are not analyzed in the FSAR. For the UMLRR, the consequences of an SSC malfunction would be bounded by the accident consequences evaluated in the FSAR. Except for the MHA, all the accident analyses show there is no consequence.

- 5: Will the PCS installation and use create a possibility for an accident of a different type than any previously evaluated in the FSAR?

No.

All credible accident scenarios have been evaluated in the UMLRR FSAR. There are no credible accidents involving the PCS that would not be bounded by the accident scenarios in the FSAR.

- 6: Will the PCS installation and use create a possibility for a malfunction of an SSC important to safety with a different result than any previously evaluated in the FSAR?

No.

The results of the accident scenarios analyzed in the FSAR, with the exception of the MHA, indicate there are no consequences. As provided previously in this evaluation, the

only malfunction common to both the old and new system would be a malfunction resulting in a loss of coolant flow. The results of this malfunction (i.e., no consequence) would be the same.

- 7: Will the PCS installation and use result in a design basis limit for a fission product barrier as described in the FSAR being exceeded or altered?

No.

As analyzed in the FSAR, there are no reactor transients or credible accidents that pose a significant risk of fuel cladding failure. The UMLRR design basis limit for the primary fission product barrier (fuel cladding) is the onset of nucleate boiling (ONB). The temperature for ONB is well below that for fuel cladding failure and the UMLRR Technical Specifications limiting safety system settings (LSSS) assure that the ONB is not reached. As indicated previously in this evaluation, SSC associated with the LSSS will be unaffected by this change.

- 8: Will the PCS installation and use result in a departure from a method of evaluation described in the FSAR used in establishing the design bases or in the safety analyses?

No.

The PCS installation does not involve a change to any analytical method used in the safety analyses provided in the FSAR.

#### DETERMINATION CONCLUSION:

The installation and operation of the PCS does not involve a modification of the Technical Specifications and meets the criteria specified in 10 CFR 50.59. As such, it may be implemented without prior NRC approval in accordance with 10 CFR 50.59.

## Reactor Safety System Block Diagrams

Fig.1 – Reactor Power Channels

Fig.2 – Coolant Flow and Temperature Channels

Start-up Channel

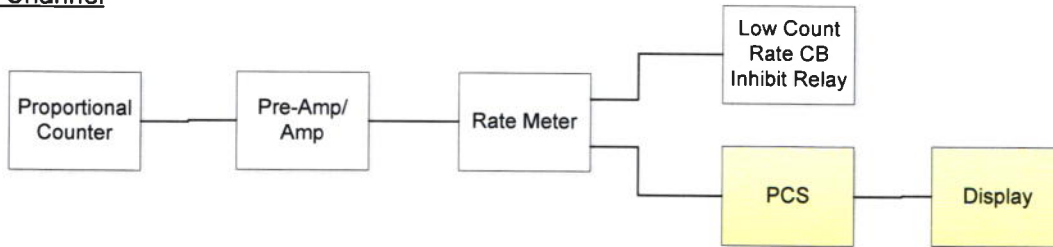

Linear Power Channels (2)

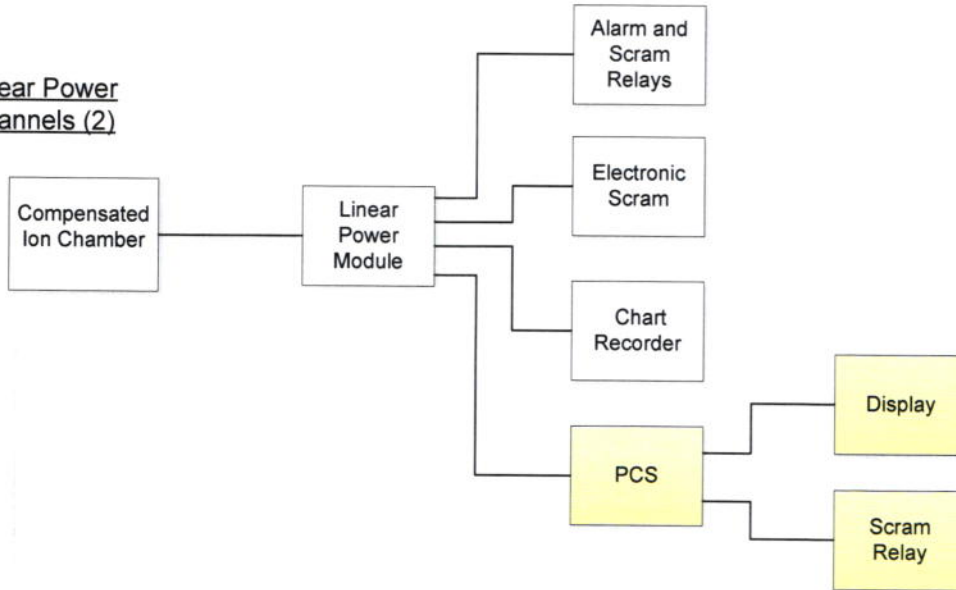

Log Power and Period Channel

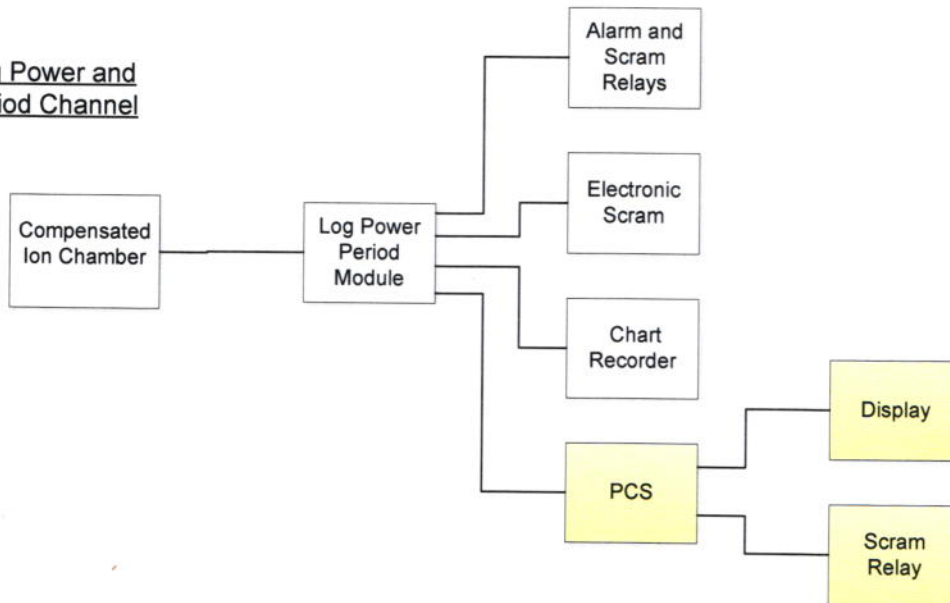
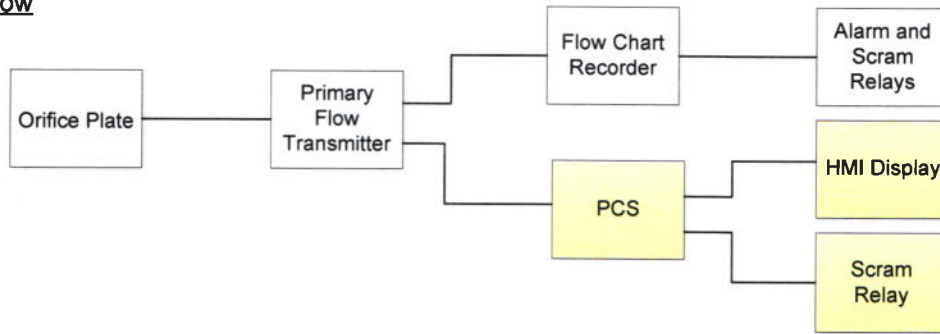

Fig. 1 Reactor Power RSS Block Diagram

New Addition

Primary Flow



Core Flow

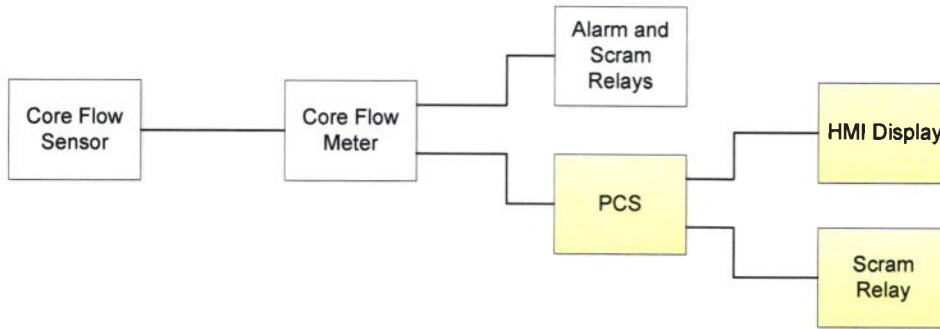

Primary Coolant Temperature (3)

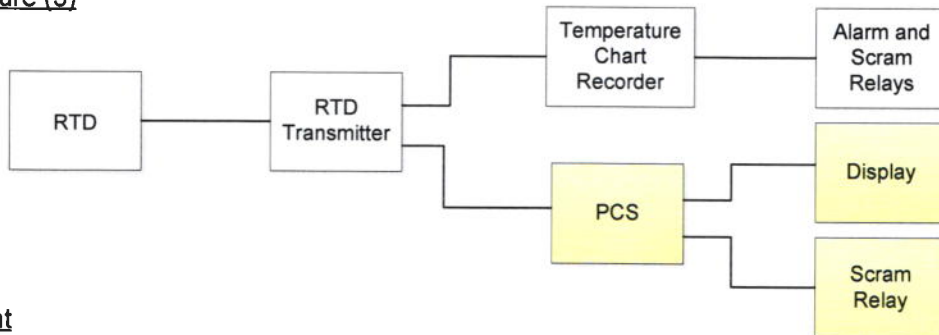

Pool Height



Pool Height

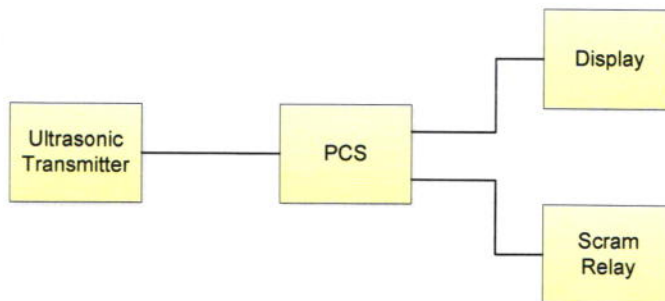

Fig. 2 Coolant Flow, Temperature, and Pool Height RSS Block Diagram

SAFETY EVALUATION DETERMINATION  
for  
UMLRR DRIVES CONTROL SYSTEM

Introduction

The safety evaluation reviews the effects and potential effects on the design bases of the reactor as a result of various upgrades to the University of Massachusetts Lowell Research Reactor (UMLRR) control element drive systems.

The UMLRR systems and components affected by these changes are described in the following sections of the UMLRR FSAR:

- 4.1.7: Control Blade Drives
- 4.1.8: Servo Regulating Rod Drive
- 4.1.9: Startup Counter Drive
- 4.4.2 Control Console
- 4.4.9 Control Blade Drive System
- 4.4.10 Startup Counter Drive System
- 4.4.11 Servo-Controlled Regulating Element Drive System
- 4.4.12 Automatic Power Level Channel

The existing *Control Blade Drive System* is described as follows (FSAR 4.4.9):

The four safety blades are normally controlled by two switches: one selects the blade to be moved; the other, a switch with a spring return, has positions RAISE, OFF, and LOWER and actuates the selected safety blade. Only one blade may be raised at a time. Digital readouts indicate the position of each safety blade.

Indicator lights on the reactor control console show when a safety blade has reached either limit of its travel. In the case of a scram, the safety blade normal control is overridden by an automatic or manual scram. Control blade drive motors are interlocked against withdrawal of blades during a 10-second delay period subsequent to reactor startup, when either picoammeter or count rate meter is below the minimum number of counts per minute.

A position indicator is provided for each control blade drive, to show drive position relative to the fully inserted position. Digital indication to the accuracy of 0.02 inch is furnished by number wheels on a mechanical counter which is chain driven from the ball-bearing screw of the drive. The indication is transmitted electrically through a segmented commutator in the counter to a "withdrawal in inches" indicator on the control console.

A "Manual Rundown" switch is also provided which, when put in the "IN" position, inserts all control blade drives simultaneously. This switch is located on the control console.

The Start-up Counter Drive System and Regulating Rod Drive System are similarly described in FSAR 4.4.10 and FSAR 4.4.11.

These systems were installed over 25 years ago and have been in use since 1974. Components in the systems are experiencing increasing age-related failures.

The mechanically driven position transmitters on each drive mechanism provide signals to the respective position indicator on the control console. Both the transmitters and indicators on each of the drives have intermittent failures (known as “skips”) that provide no indication of position at various withdrawal/insertion positions. The transmitters, indicators, and the electric motors for the drives are no longer manufactured by General Electric (GE).

The indicator lights for the full-in and full-out drive limits often burn out. Some indicators have failed altogether due to bulb socket issues.

Switch contacts for the control blade drive selector switch often make intermittent contact which results in no manual drive motion when the contact is not made. The switch often has to be rotated back and forth several times until the electrical contact is made.

The springs in the spring return manual control switches used for operating the drives are aging to the point where occasionally the switches do not automatically return to the off position when the operator releases the control. The operator must make an effort to assure the switch is in the off position after positioning the drive.

The automatic regulating rod drive servo control described in FSAR 4.4.11 and 4.4.12 that is used to automatically maintain the reactor power level has not worked for the past several years. The servo amplifier is a vacuum tube based system designed by GE to interface with the GE linear power monitor. The GE linear power monitors are no longer manufactured and were replaced with the General Atomics monitors in 1998. Since then, the operators have had to rely on manual control to maintain reactor power level at a steady state.

### **Detailed Description of Changes**

The upgrade encompasses:

- a. New display for monitoring and controlling drive position
- b. New control blade/rod drive motors
- c. New limit switches for drives
- d. New position encoders for drives
- e. Automatic control of regulating rod

These upgrades comprise what is collectively referred to as the Drives Control System (DCS).



### Control Console Display

The right side of the control room control console originally housed the control blade drive selector switch, the control blades manual rundown switch, the control blade manual control switch, the regulating rod drive manual control switch, the start-up counter drive switch, and the six drive position indicators. Mounted to the position indicators were the drive power ON indicator light, and drive limit switch indicator lights. These controls and indicators have been replaced with a touch-screen graphical user interface (GUI) display.

The DCS is built upon the OPTO 22 hardware and software used in the recent upgrades to the area radiation monitoring system and process controls system. The DCS hardware upgrades and specific software development were done by an engineering consultant. The UMLRR staff worked closely with the engineering consultant during the design, installation, and testing phases.

Field devices, including the motor controllers, position encoders, and limit switches, are connected to various input/output (I/O) modules located on an I/O rack. Data from each I/O module is communicated to the main processor (controller). The controller also issues commands to the I/O and relays data to the GUI display computer. The GUI displays the information received from the controller and provides a touch screen and a keyboard terminal for the manual control of the drives. Additional descriptions of the OPTO 22 hardware and software may be found in the previous evaluations for the process controls and area radiation monitoring systems.

Similar to the process control system (PCS), the DCS also includes a dry contact relay connected to the scram chain. If communication between the I/O rack, controller, or display is lost, the relay will open and scram the reactor.

### Drive Motors (FSAR 4.1.7)

The six original electric drive motors will be replaced with brushless DC-servomotors. The drive mechanism for each drive remains unchanged. The most important factor associated with the motors is how they affect the drive speed. The control blade drive motor speeds are limited such that the reactivity addition rate is below the technical specification limiting condition for operation. The maximum speed of the servo motor is limited by means of a fixed, hard-wired resistor. The original motors produced a drive speed of approximately 3.7 inches/min. The new motors produce the same drive speeds.

The regulating rod drive motor maximum speed is approximately 40 in/min as result of the new motor. While this is considerably less than the FSAR described maximum speed of 78 in/min, the actual speed with the original motor was approximately 68 in/min. The lower reactivity addition rate associated with the lower speed is still more than adequate for small adjustments to the reactor power level and for responding to anticipated reactivity changes such as movable experiments.

### Limit Switches (FSAR 4.1.7)

The limit switches de-energize the motors to prevent damage to the drive mechanism when the drive components have reached the full-in or full-out position. As mentioned in the FSAR, mechanical stops are also available in case of limit switch failure. The up and down limit electromechanical micro-switches will be replaced with through-beam photo-microsensors. The electromechanical micro-switches use a flexible metallic strip that depresses the switch when a metal “flag” on the lead screw ball nut pushes against the metal strip. The same flag will be used for the through-beam sensor to intersect the beam.

### Position Indicator

The electro-mechanical transmitters for position indication will be replaced with an optical encoder that generates an electronic pulse at each revolution of the encoder. The encoder is integral with the drive motor. The revolutions of the encoder are counted by an input module, converted to a measurement in inches, and displayed on the graphical user interface. The electro-mechanical transmitter accuracy is 0.02 inch (FSAR 4.1.7). The accuracy with the encoder will be 10 times more accurate, in addition to providing position information for the full range of motion for the drive as opposed to the intermittent data available with the present position transmitters and indicators.

### Servo-controlled Regulating Element Drive System

The servo amplifier for automatic control will be replaced with a PID (proportional gain, integral, derivative) controller. When the operator places the system in automatic mode, the PID controller will maintain the reactor power at a desired set-point level by controlling the output signal to the regulating rod drive servomotor.

The desired set-point level is the measured reactor power level signal when servo system is placed in the closed-loop automatic mode. The power is measured using one of the available optically isolated analog outputs from one of the linear power monitors. The difference between the set-point value and measured power level signal will generate an error value. The output signal to drive the servomotor, and increase or decrease the reactor power level signal, is dependent on the error value. In essence, the automatic control may be best compared to the “cruise control” system available in automobiles. The operator initiates and cancels the automatic mode using the GUI.

### DCS Quality Assurance Testing

During various phases of the DCS installation, functional testing of the hardware and software was performed. The following procedures were performed to assure the new system and the all affected reactor safety and non-reactor safety system channels operate in the fashion described by the FSAR and meet technical specification requirements:

SP-16 Rod Drop and Drive Measurements  
SP-23 Scram Function Test  
RO-9 Reactor Checkout

In addition, a preoperational checklist was created to detect and troubleshoot problems with the system during the testing phase. All possible combinations of control sequences (e.g., control blade withdrawal/insertion, reg. rod withdrawal/insertion, SUC withdrawal/insertion, reg. rod mode placed in auto/manual) were initiated to affect and observe the operation of the system.

### Safety Review

The major differences between the original system components and the upgrade are the digital conditioning of signals, the PID controller for automatic control of the regulating rod, and the GUI display for operator interface. The system has been designed to maintain the same functionality of the original system. The previous drive system and the current drive system remain independent of the reactor safety system (with the exception of the added DCS scram relay). The control blade scram magnets and the method for energizing and de-energizing them have remained unchanged. All the drive interlocks as described in FSAR 4.4.9 remain unchanged. The electrical power to the control blade drive motors is connected via hard-wired mechanical relays. The relay logic prevents more than one control blade to operate in the up direction (blade withdrawal) at any one time.

The technical specifications associated with the drives are the limiting conditions of operation for the control blade and regulating rod maximum reactivity addition rates and the drive time surveillance requirement for determining reactivity addition rates. None of these require a change or will be affected by the DCS. Therefore no changes to the technical specifications are required.

The new drive system has been thoroughly tested using existing procedures and a preoperational checklist. Some procedures, such as pre-critical check-out (RO-9) and scram functions test (SP-23) have been changed to reflect the new system.

In addition to the internal review and documentation required by 10CFR 50.59, all procedure changes will be reviewed by the RSSC as necessary and in accordance with procedure AP-2 Procedure Changes. Updates to the reactor FSAR descriptions will be made.

## DCS SAFETY EVALUATION

### Introduction

Changes to facility design, as it is described in the final safety analysis report (FSAR) are allowed under regulation 10CFR50.59 without review by the NRC,

provided the Technical Specifications are not changed, and that criteria outlined below are met.

The evaluation should demonstrate that the change will not:

- (1) Result in more than a minimal increase in the frequency of occurrence of an accident previously evaluated in the FSAR;
- (2) Result in more than a minimal increase in the likelihood of occurrence of a malfunction of a structure, system, or component (SSC) important to safety previously evaluated in the FSAR;
- (3) Result in more than a minimal increase in the consequences of an accident previously evaluated in the FSAR;
- (4) Result in more than a minimal increase in the consequences of a malfunction of an SSC important to safety previously evaluated in the FSAR;
- (5) Create a possibility for an accident of a different type than any previously evaluated in the FSAR;
- (6) Create a possibility for a malfunction of an SSC important to safety with a different result than any previously evaluated in the FSAR;
- (7) Result in a design basis limit for a fission product barrier as described in the FSAR being exceeded or altered; or
- (8) Result in a departure from a method of evaluation described in the FSAR used in establishing the design bases or in the safety analyses.

#### TECHNICAL SPECIFICATIONS EFFECT

There are no Technical Specifications affected by the DCS that would require a change. Subsequently, no technical specification change is required for this modification.

#### SAFETY DETERMINATION:

The postulated accident scenarios evaluated in the UMLRR FSAR include: Loss of Coolant Flow; Loss of Coolant (considered the design basis accident); Refueling Accident; Step and Ramp Reactivity Increase; and External Events. **The analyses conclude that none these reactor transients or other accidents evaluated would result in fuel cladding and subsequent release of radioactivity.** In addition, a maximum hypothetical accident (MHA) involving the release of fission products from

one fuel plate is also analyzed to determine the hypothetical radiological consequences. The MHA is not a credible accident and has no initiating event.

Of the scenarios analyzed in the FSAR, only Ramp Insertion of Reactivity may be considered as affected by installation and use of the DCS.

The most recent analyses of Ramp Insertion of Reactivity are provided in the FSAR (LEU Conversion Supplement to the FSAR 3.1.2.9). Two analyses are given, both at an initial condition of 1MW steady state power. One analysis is for the maximum technical specification reactivity addition rate for the regulating rod and one for the maximum technical specification reactivity addition rate for a control blade. Both analyses conclude the maximum power level upon scram by the power measuring channels is well below the onset of nucleate boiling established for the Safety Limit. Also of interest is the analysis given in the Safety Evaluation Report (SER). The SER (14.2.2) analyzes a ramp insertion based upon the failure of all interlocks resulting in the simultaneous withdrawal of all four control blades from critical at 5W. This analysis (done for the less conservative HEU core) concludes that no fuel damage would occur. As described previously, the speed of motors (withdrawal rate) has not increased and the motors are hard-wired such that only one control blade can be withdrawn at one time. As a result, these analyses and conclusions remain unchanged.

#### 10 CFR 50.59 EVALUATION

- 1: Will the DCS installation and use result in more than a minimal increase in the frequency of occurrence of an accident previously evaluated in the FSAR?

No.

The frequency of occurrence of accidents is not analyzed in the FSAR and probabilistic risk assessments are not required for non-power reactors. Though not addressed in the FSAR analyses, the initiating event for a reactivity ramp insertion transient could be either a system/component failure or an operator error. As reliability data is unavailable for either the existing or the new system, the frequency of occurrence of a reactivity ramp insertion transient due to a system or component failure is unknowable. In regards to operator error (e.g., continually withdrawing a control rod after 1MW is reached), again there is no data available for the frequency of occurrence. However, since for either the existing or the new system, the operator must perform the actions for rod withdrawal and is responsible for observing and responding to the reactor dynamics data, the possibility of operator error would remain unchanged.

- 2: Will the DCS installation and use result in more than a minimal increase in the likelihood of occurrence of a malfunction of a structure, system, or component (SSC) important to safety previously evaluated in the FSAR?

No.

The likelihood of occurrence of SSC malfunctions is not evaluated in the FSAR. Since probability risk assessments are not performed, there is no reliability data available on SSCs to adequately determine the probability of occurrence of malfunctions. In addition,

the DCS is independent of the reactor safety system and the associated SSC. No changes have been made to scram magnets, their power supply, or the reactor safety system with the exception of the addition of a scram relay. The addition of a dry contact scram relay for the DCS in series with the scram relay chain (safety chain) does not negatively affect the safety chain since any single open relay in the series circuit will result in a scram.

- 3: Will the DCS installation and use result in more than a minimal increase in the consequences of an accident previously evaluated in the FSAR?

No.

The consequence of concern is for a continuous (ramp) reactivity insertion. The analyses shows there are no consequences from this accident. No changes are being made such that the drives speed would increase and thereby increase reactivity addition rate beyond that used in the analyses. As the drives speeds will not change, the DCS will have no effect on the transient consequence or lack thereof.

- 4: Will the DCS installation and use result in more than a minimal increase in the consequences of a malfunction of an SSC important to safety previously evaluated in the FSAR?

No.

Malfunctions of SSC resulting in a radiological consequence are not analyzed in the FSAR. For the UMLRR, the consequences of an SSC malfunction would be bounded by the accident consequences evaluated in the FSAR. Except for the MHA, all the accident analyses show there is no consequence.

- 5: Will the DCS installation and use create a possibility for an accident of a different type than any previously evaluated in the FSAR?

No.

All credible accident scenarios have been evaluated in the UMLRR FSAR. There are no credible accidents involving the DCS that would not be bounded by the accident scenarios in the FSAR. Any accident scenario involving the DCS would be within the envelope of the ramp reactivity insertion accident analyzed and evaluated in the FSAR.

- 6: Will the DCS installation and use create a possibility for a malfunction of an SSC important to safety with a different result than any previously evaluated in the FSAR?

No.

The results of the accident scenarios analyzed in the FSAR, with the exception of the MHA, indicate there are no consequences. The only malfunction common to both the old and new system would be a malfunction resulting in a ramp reactivity insertion. The results of this malfunction (i.e., no consequence) would be the same.

- 7: Will the DCS installation and use result in a design basis limit for a fission product barrier as described in the FSAR being exceeded or altered?

No.

As analyzed in the FSAR, there are no reactor transients or credible accidents that pose a significant risk of fuel cladding failure. The UMLRR design basis limit for the primary

fission product barrier (fuel cladding) is the onset of nucleate boiling (ONB). The temperature for ONB is well below that for fuel cladding failure and the UMLRR Technical Specifications limiting safety system settings (LSSS) and limiting conditions for operation (LCO) assure that the ONB is not reached. The only technical specification affected by this change is LCO for reactivity insertion rate. Since the drive speed remains unchanged (or slower for the regulating rod), there is no effect on the design basis limit.

- 8: Will the DCS installation and use result in a departure from a method of evaluation described in the FSAR used in establishing the design bases or in the safety analyses?

No.

The DCS installation does not involve a change to any analytical method used in the safety analyses provided in the FSAR.

DETERMINATION CONCLUSION:

The installation and operation of the DCS does not involve a modification Technical Specifications and meets the criteria specified in 10 CFR 50.59. As such, it may be implemented without prior NRC approval in accordance with 10 CFR 50.59.

10CFR50.59 Evaluation for Secondary Cooling System Remote Control  
March 14, 2008

**Purpose**

In order to further enhance the versatility of the UMLRR for engineering education, in particular for practicums related to thermodynamics, it is desirable to allow limited remote control of the reactor secondary cooling system. With increased security requirements and limited space in the reactor control room, it is difficult or impractical to run demonstrations for classes with large numbers of students. The remote control of the secondary cooling system would include on/off control of the cooling tower fans and the ability to adjust the secondary system flow rate via the secondary system motor-operated valve (MOV). Along with the ability to remotely monitor temperatures and flow rates of the primary and secondary cooling systems, access to the secondary system components will allow for opportunities to run an interactive real-time thermodynamics experiment.

**System**

The secondary system is described in FSAR 4.2.3. The remote control of the secondary system components will be accomplished using a stand-alone PC server running a supervisory control and data acquisition (SCADA) software package developed by Indusoft. The remote control of the cooling tower fans and the secondary MOV will be via an Ethernet connection.

A variety of security features will be implemented to minimize the possibility of unauthorized use of the system and to guard against inadvertent misuse of the secondary cooling system components controls by an authorized user. To prevent unauthorized access or misuse, a manual on/off switch in the control room is used to connect or disconnect the Ethernet connection. Additionally, an on/off Remote Control toggle switch has been added to the reactor control console. This switch is controlled by the reactor operator and it is only activated if a remote control experiment or demonstration has been scheduled. This switch provides a 24VDC signal to the SCADA system indicating control has been allowed. All control capability is inactive unless the Remote Control switch is on. In addition, this switch is electronically connected to the reactor master control on/off switch which is key locked. **Therefore, a reactor operator must be in the reactor control room in order for the hard-wired Remote Control switch to be on.**

Within the InduSoft software application itself, security is introduced through a user account and password system. Without a proper user name and password, a remote user cannot get access to the system. Once the initial login authentication process is successful, each user is assigned to a security group, where each group has a different level of privileges within the system. At present there are two groups: *admin* and *guest*. Users within the admin group (reactor staff or faculty member) have full privileges and, in particular, they can assign a single user within any group access to the controls on the secondary side. Only a single user account can be assigned control capability at any one



time. This is controlled through an additional screen that can only be seen by users in the admin group (this screen is invisible to the guest user groups). The administrative screen also contains a Deactivate button, which will immediately shut off control for all users if any misuse of the controls is observed.

### **Effects on Reactor Safety**

Situations that may affect the safety of the reactor are controlled automatically via the existing reactor safety system. As always, if any abnormal condition is detected, the reactor will simply automatically shut down. However, there is nothing associated with the reactor secondary coolant system that can significantly affect the short term operation of the primary coolant system. The worse-case situation might involve a rapid change in the amount of secondary cooling (e.g., a secondary coolant temperature near 32°F) which could change the **pool inlet** coolant temperature rapidly by about 10 – 20 F and the **core inlet** temperature by a few degrees (because of mixing in the large pool before entering the core region). A 5° F decrease in the core inlet temperature will result in a positive reactivity effect of ~ 0.01%  $\Delta k/k$ . This value is 1/10<sup>th</sup> the allowable reactivity value for a movable experiment in the reactor core. This temperature effects analysis shows that the secondary system, even under extreme conditions, has a negligible effect on the reactor dynamics.

The implemented security measures are primarily to ensure proper use of the facility by authorized users for educational purposes. As is always the case, the ultimate control of the facility at all times is the responsibility of the reactor operator. The reactor operator can easily turn off the Remote Control switch or simply switch off or remove the Ethernet cable that connects to the InduSoft SCADA server. Thus, the implementation of limited remote control of the secondary cooling system will have no impact on reactor safety.

## SECONDARY COOLING SYSTEM REMOTE CONTROL SAFETY EVALUATION

### Introduction

Changes to facility design, as it is described in the final safety analysis report (FSAR) are allowed under regulation 10CFR50.59 without review by the NRC, provided the Technical Specifications are not changed, and that criteria outlined below are met.

The evaluation should demonstrate that the change will not:

- (1) Result in more than a minimal increase in the frequency of occurrence of an accident previously evaluated in the FSAR;
- (2) Result in more than a minimal increase in the likelihood of occurrence of a malfunction of a structure, system, or component (SSC) important to safety previously evaluated in the FSAR;
- (3) Result in more than a minimal increase in the consequences of an accident previously evaluated in the FSAR;

- (4) Result in more than a minimal increase in the consequences of a malfunction of an SSC important to safety previously evaluated in the FSAR;
- (5) Create a possibility for an accident of a different type than any previously evaluated in the FSAR;
- (6) Create a possibility for a malfunction of an SSC important to safety with a different result than any previously evaluated in the FSAR;
- (7) Result in a design basis limit for a fission product barrier as described in the FSAR being exceeded or altered; or
- (8) Result in a departure from a method of evaluation described in the FSAR used in establishing the design bases or in the safety analyses.

#### TECHNICAL SPECIFICATIONS EFFECT

The Technical Specifications of the UMLRR do not reference the reactor secondary cooling system. Therefore, there are no Technical Specifications affected by modifications to the reactor secondary cooling system that would require a change. Subsequently, no technical specification change is required for this modification.

#### SAFETY DETERMINATION:

The postulated accident scenarios evaluated in the UMLRR FSAR include: Loss of Coolant Flow; Loss of Coolant (considered the design basis accident); Refueling Accident; Step and Continuous Reactivity Increase; and External Events. **The analyses conclude that none these reactor transients or other accidents evaluated would result in fuel cladding and subsequent release of radioactivity.** In addition, a maximum hypothetical accident (MHA) involving the release of fission products from one fuel plate is also analyzed to determine the hypothetical radiological consequences. The MHA is not a credible accident and has no initiating event. The FSAR also analyzes for a cold water insertion event. Using an extreme and unrealistic scenario where the primary coolant temperature goes from 100°F to 32°F, the core reactivity addition is approximately 0.3%dk/k. This is less than the 0.5%dk/k analyzed for a step reactivity increase. To produce 0.5% change would require an even more unrealistic temperature step decrease of approximately 180°F. The more realistic calculation presented in this document shows a *negligible reactivity effect* associated with use of the secondary cooling system, even under extreme conditions.

## 10 CFR 50.59 EVALUATION

- 1: Will the secondary cooling system remote control (SCSRC) installation and use result in more than a minimal increase in the frequency of occurrence of an accident previously evaluated in the FSAR?

No.

The frequency of occurrence of the cold water insertion transient is not analyzed in the FSAR. Normally, the secondary system is directly controlled by the reactor operator. As such, the actions of the reactor operator would be the initiator of the event. The frequency of occurrence would then be a function of operator action. Given the operator must be present at the controls, whether remote control is used or not, the frequency of occurrence would be the same.

- 2: Will the SCSRC installation and use result in more than a minimal increase in the likelihood of occurrence of a malfunction of a structure, system, or component (SSC) important to safety previously evaluated in the FSAR?

No.

The likelihood of occurrence of SSC malfunctions is not evaluated in the FSAR. There is no reliability data available on SSCs to adequately determine the probability of occurrence of malfunctions. Additionally, the secondary cooling system is not considered an SSC important to safety. The effects of its use have been shown to be negligible on reactor safety.

- 3: Will the SCSRC installation and use result in more than a minimal increase in the consequences of an accident previously evaluated in the FSAR?

No.

The consequence of concern is a step increase in reactivity. The analyses have shown that 0.5% dk/k step increase at full power has no consequence.

- 4: Will the SCSRC installation and use result in more than a minimal increase in the consequences of a malfunction of an SSC important to safety previously evaluated in the FSAR?

No.

Malfunctions of SSC resulting in a radiological consequence are not analyzed in the FSAR. For the UMLRR, the consequences of an SSC malfunction would be bounded by the accident consequences evaluated in the FSAR. Except for the MHA, all the accident analyses show there is no consequence. The consequences of any SSC malfunction associated with installation and use of the SCSRC would be bounded by the accident consequences of a step reactivity increase (see Question #3).

- 5: Will the SCSRC installation and use create a possibility for an accident of a different type than any previously evaluated in the FSAR?

No.

All credible accident scenarios have been evaluated in the UMLRR FSAR. There are no credible accidents involving the SCSRC that would not be bounded by the accident scenarios in the FSAR. Any accident scenario involving the SCSRC would be within the envelope of a step reactivity insertion analyzed in the FSAR.

- 6: Will the SCSRC installation and use create a possibility for a malfunction of an SSC important to safety with a different result than any previously evaluated in the FSAR?

No.

The results of the accident scenarios analyzed in the FSAR, with the exception of the MHA, indicate there are no consequences. The credible accident scenario for a step reactivity insertion, which could be initiated by an SCSRC equipment malfunction, has been shown to have no consequence.

- 7: Will the SCSRC installation and use result in a design basis limit for a fission product barrier as described in the FSAR being exceeded or altered?

No.

The design basis limit for the primary fission product barrier (fuel cladding) is the onset of nucleate boiling (ONB). A 0.5%  $\Delta k/k$  step reactivity addition has been shown in the FSAR to be below that necessary for ONB.

- 8: Will the SCSRC installation and use result in a departure from a method of evaluation described in the FSAR used in establishing the design bases or in the safety analyses?

No.

The SCSRC installation does not involve a change to any analytical method used in the safety analyses provided in the FSAR.

#### DETERMINATION CONCLUSION:

The installation and operation of the SCSRC does not involve a modification Technical Specifications and meets the criteria specified in 10 CFR 50.59. As such, it may be implemented without prior NRC approval in accordance with 10 CFR 50.59.

**50.59 SCREEN**

**Activity Screening Number:**

**Title:**

**Description of Activity (what is being changed and why):**

See attached

**50.59 Screening Questions:**

1. Does the proposed activity adversely affect an SSC design function described in the FSAR?  
 YES  NO
2. Does the proposed activity adversely affect a method of performing or controlling an SSC design function described in the FSAR?  YES  NO
3. Does the proposed activity involve revising or replacing a FSAR described evaluation methodology that is used in establishing the design bases or used in the safety analyses?  YES  NO
4. Does the proposed activity involve a test or experiment not described in the FSAR, where an SSC is utilized or controlled in a manner that is outside the reference bounds of the design for that SSC or is inconsistent with analyses or descriptions in the FSAR?  YES  NO
5. Does the proposed activity require a change to the UMLRR Tech Specs?  YES  NO

If all screening questions are answered NO, then implement the activity per the applicable approved facility procedure(s). A License Amendment or a 50.59 Evaluation is not required.

If Screen Question 5 is answered YES, then request and receive a License Amendment prior to implementation of the activity.

If Screen Question 5 is answered NO and Question 1, 2, 3, or 4 is answered YES, then complete and attach a 50.59 Evaluation form. [Refer to Attachment 2]

**NOTE:** If the conclusion of the screening question is that a 50.59 Evaluation is not required, provide a justification for the "No" determination. In addition, list the documents (FSAR, Technical Specifications, and other Licensing Basis documents) reviewed where relevant information was found. Include section / page numbers. Use page 2 of this form to document your statements.

	Print Name	Sign Name	Date
<b>Preparer (SRO):</b>			
<b>Reactor Supervisor</b>	<i>L. Bobek</i>	<i>[Signature]</i>	<i>3/29/10</i>

**50.59 SCREEN (Cont.)**

Screen No.

If the conclusion of the five (5) Screening Questions is that a 50.59 Evaluation is not required, provide justification to support this determination: *[Use and attach additional pages as necessary.]*

1. Does the proposed activity adversely affect an SSC *design function* described in the FSAR?

See attached.

2. Does the proposed activity adversely affect a method of performing or controlling an SSC *design function* described in the FSAR?

See attached.

3. Does the proposed activity involve revising or replacing an evaluation methodology that is used in establishing a *design bases* or used in a *safety analyses* described in the FSAR?

See attached.

4. Does the proposed activity involve a *test or experiment not described in the FSAR*, where an SSC is used or controlled in a manner that is outside the reference bounds of the design for that SSC, or is inconsistent with analyses or descriptions presented in the FSAR?

See attached.

List the documents (FSAR, Technical Specifications, and SER) reviewed where relevant information was found (include section / page numbers).

See attached.

End of Screen

Description of changes to be made to the drive control system:

1. Limit Switch and Drive Relays:

The drive motors, as upgraded in 2003, rely on software logic for stopping the motors when the control blade drive limit switches indicate the drive has reached the full-out or full-in position. Additionally, as described in the FSAR, mechanical stops located at the upper and lower positions prevent damage to the to the drive tube and control blade in the event a limit switch fails. A torque limiter coupling that connects from the drive motor to the drive screw prevents damage to the motor in the event a limit switch fails. In conjunction with the position encoders presently used (item #2 below), the present configuration has led to a few instances where the drive motor torque limiter coupling has released from the drive shaft, preventing damage to the motor when the down limit was reached and the motor did not immediately stop. To remedy this, both the full-out and full-in limit switches on the drives will be hard-wired to relays that will interrupt power to the motor. Hard-wired relays were used with the original motors prior to the drive controls upgrade in 2003.

2. Positional encoder upgrade:

An encoder upgrade will eliminate the existing pulse reduction circuit which was installed in 2003 to accommodate limitations in the I/O module used for counting pulses to determine positional indication. Each full rotation of the motor produces a pulse in the encoder which is correlated to a change in linear position. The pulses are counted to determine the change in linear position. Since the pulse rate from the motor is greater than resolution of the I/O module used to count the pulses, a pulse reduction circuit is employed to reduce the number of pulses to within the resolution of the I/O module. This configuration has led to occasional minor positional inaccuracies (several one hundredths of an inch). The new encoder will be moved from the drive motor to the control drive shaft which will result in fewer revolutions per inch to be counted by the I/O module, eliminating the need for the pulse reduction circuit. An additional benefit is that any disconnect between the control drive shaft and the motor coupling will allow the operator to determine that the control rod is not moving.

3. Wiring Replacement:

The original wiring for the motor power, control blade magnet power, and various limit switches is nearly 40 years old. The insulation on the magnets wiring, in particular, is cracked and frayed. These wires will be replaced with wires of the exact type and gauge as the originals.

50.59 Screening Questions:

1. Does the proposed activity adversely affect an SSC *design function* described in the FSAR?

No. The design function of the drives as described in the FSAR and 2003 SED (50.59) is to move the control blades in out of the reactor core to affect reactivity changes. The rate of movement is such that the reactivity addition rate shall remain below the limiting condition of operation established in the technical specifications. This is governed by the drive motor speed and reactivity worth of the control blades. Items 1-3 do not affect the speed or reactivity worth of the control of the control blades. Subsequently, the design function remains unchanged.

2. Does the proposed activity adversely affect a method of performing or controlling an SSC *design function* described in the FSAR?

No. The control blade drive mechanism is described in the FSAR. The method for controlling the control blade movement is by actuation of drive mechanism as described in the FSAR and 2003 SED (50.59). The drive mechanism actuation is performed and controlled by the reactor operator using controls in the control room. Items 1-3 do not adversely affect the operator controls. The method of controlling the drives remains the same.

3. Does the proposed activity involve revising or replacing an evaluation methodology that is used in establishing a *design bases* or used in a *safety analyses* described in the FSAR?

Since the rate of reactivity addition or reactivity worth of the control of the control blades is unaffected, the evaluation methodologies described in the FSAR are not affected.

4. Does the proposed activity involve a *test or experiment not described in the FSAR*, where an SSC is used or controlled in a manner that is outside the reference bounds of the design for that SSC, or is inconsistent with analyses or descriptions presented in the FSAR?

The activity does not involve a test or experiment such that the drive mechanism and controls would be used in manner that could exceed limiting conditions of operation and is consistent with descriptions in the FSAR.

The UMLRR systems and components affected by these changes are described in the following sections of the UMLRR FSAR:

- 4.1.7: Control Blade Drives
- 4.1.8: Servo Regulating Rod Drive
- 4.4.2 Control Console
- 4.4.9 Control Blade Drive System



10CFR50.59 Evaluation for Chart Recorder Replacement  
January 12, 2012

Proposed Change – Purpose and Description

The two Leeds Northrup (LN) chart recorders -- one for the primary coolant temperatures and one for the primary flow and secondary flow rates -- will be replaced with Omega (Series RD 200) chart recorders. The LN recorders replaced the original GE recorders in 1989 and are now over 20 years old. They are increasingly difficult to calibrate. Control room operators have observed and corrected occasional binding of the chart pens. Also, there is now only one overseas supplier of pens and paper for the recorders.

As described in the manufacturer literature, the RD200 Series chart recorders are 100 mm, multipoint, hybrid recorders that can print/display multichannel and alarm data simultaneously. Channel inputs are available for RTD, thermocouple and DC voltage signals. The user can program up to 4 levels of alarms for each channel; optional alarm outputs are available. The recorders display alarm settings (status and channels), and can print channel alarms and alarm numbers. The RD200 Series chart recorders are manufactured in a ISO9001-certified facility and conform to CE, UL, and CSA safety standards.

The existing LN flow chart recorder is of the two pen variety -- one for primary flow, one for secondary flow. The LN temperature recorder is three pen – primary inlet, primary outlet, and pool. Both recorders have a relay outputs for alarm and scram functions.

While the LN chart recorders use analog electronics, the Omega recorders are a “hybrid” mix of analog and digital components. The Omega recorders also have relay outputs for alarm and scram functions. One additional difference is the Omega recorders are designed for a direct input from an RTD temperature sensor. The LN recorders are designed for 4-20mA and/or 0-10VDC input. As a result, the RTDs for the primary coolant are connected to a signal transmitter that converts the mV input signal from the RTDs to a 4-20mA current output to the recorder. The transmitters will no longer be needed for the Omega recorder. The transmitter for primary flow is unaffected.

No data is available on the resolution of LN recorders. However, previous calibration data show the flow accuracy to be within +/- 40 GPM and temperature within 1.5°F. The resolution of the Omega recorder for flow is +/- 20 GPM based on a maximum 2000 GPM flow at a 10VDC measured transducer output and a stated resolution of 10mV. The resolution of the temperature recorder for a type-Pt100 RTD is stated as 0.1°C (~0.2°F). The resolution and accuracy of the recorders is within that referenced in calibration procedures, +/- 40GPM and +/- 1.5°F.

## Recorder Calibration and Testing

As required by Technical Specification 4.2.6, any reactor safety system instrument replacement must undergo a channel check prior to installation and a calibration before routine operation after the installation. The recorders have been bench tested and checked for signal response using an RTD simulator for the temperature recorder and a current source for the flow recorder. In addition, the relay action was also checked. The recorders have been installed and the calibration checked using the existing RTDs for the primary coolant, and the existing flow sensors for the primary and secondary coolant. The calibration procedures used for these checks are: CP-4 Calibration of Temperature Monitor Devices and CP-5 Calibration of Flow Measuring Devices. Very minor changes are needed for these procedures. In both instances the steps for the calibration checks remain the same. The RTDs are immersed in hot, cold, and ambient temperature water baths and readings checked against a calibrated thermometer. The only change for this procedure will be a statement to refer to the recorder manual for any needed calibration adjustments. The flow sensors use the application of compressed air pressure that is measured by a calibrated pressure gauge then applied to the pressure transducer to simulate flow pressure. Each calibration has shown the recorders to be accurate over their intended range of use and the calibration data has been placed on file. Minor changes to the reactor checkout procedure will be made to reflect minor changes to how the temperature and flow trips are checked prior to start-up. As with the previous recorders, the trips are checked by adjusting the trip set-point until trip occurs and then returning the set-point to its proper setting. All licensed operators will be trained on the use of the new recorders.

## SAFETY EVALUATION

### INTRODUCTION

Changes to facility design, as it is described in the final safety analysis report (FSAR) are allowed under regulation 10CFR50.59 without review by the NRC, provided the Technical Specifications are not changed, and that the criteria outlined below are met.

The evaluation should demonstrate that the change will not:

- (1) Result in more than a minimal increase in the frequency of occurrence of an accident previously evaluated in the FSAR;
- (2) Result in more than a minimal increase in the likelihood of occurrence of a malfunction of a structure, system, or component (SSC) important to safety previously evaluated in the FSAR;
- (3) Result in more than a minimal increase in the consequences of an accident previously evaluated in the FSAR;

- (4) Result in more than a minimal increase in the consequences of a malfunction of an SSC important to safety previously evaluated in the FSAR;
- (5) Create a possibility for an accident of a different type than any previously evaluated in the FSAR;
- (6) Create a possibility for a malfunction of an SSC important to safety with a different result than any previously evaluated in the FSAR;
- (7) Result in a design basis limit for a fission product barrier as described in the FSAR being exceeded or altered; or
- (8) Result in a departure from a method of evaluation described in the FSAR used in establishing the design bases or in the safety analyses.

#### TECHNICAL SPECIFICATIONS EFFECT

There are no changes to any of the technical specifications associated with temperature and flow limits, measurements, or surveillances. No technical specification change is required for this modification.

#### SAFETY DETERMINATION:

The postulated accident scenarios evaluated in the UMLRR FSAR include: Loss of Coolant Flow; Loss of Coolant (considered the design basis accident); Refueling Accident; Step and Continuous Reactivity Increase; and External Events. **The analyses conclude that none these reactor transients or other accidents evaluated would result in fuel cladding and subsequent release of radioactivity.** In addition, a maximum hypothetical accident (MHA) involving the release of fission products from one fuel plate is also analyzed to determine the hypothetical radiological consequences. The MHA is not a credible accident and has no initiating event.

Both temperature and coolant flow rate are considered in the safety analyses (FSAR Conversion to LEU Supplement). The limiting safety system setting (LSSS) have been established to assure the safety limits are not exceed for the analyzed transients. The LSSS for core inlet temperature is 110<sup>0</sup>F and the LSSS for primary coolant flow is 1170 GPM. The two analyzed transients affected by the chart recorders are Loss of Coolant Flow and the Step and Continuous Reactivity Increase

#### 10 CFR 50.59 EVALUATION CHECKLIST

- 1: Will the chart recorder replacement result in more than a minimal increase in the frequency of occurrence of an accident previously evaluated in the FSAR?

No.

The frequency of occurrence of accidents is not analyzed in the FSAR and probabilistic risk assessments (PRA) are not required for non-power reactors. In addition, the chart recorders are passive measurement devices and therefore cannot affect the initiation of or occurrence of either transient.

- 2: Will the chart recorder replacement result in more than a minimal increase in the likelihood of occurrence of a malfunction of a structure, system, or component (SSC) important to safety previously evaluated in the FSAR?

No.

The likelihood of occurrence of SSC malfunctions is not evaluated in the FSAR. Since probability risk assessments are not performed, there is no reliability data available on SSCs to adequately determine the probability of occurrence of malfunctions. For a qualitative assessment, the functionality of recorders remains unchanged – that being to measure the parameter and to provide an alarm and reactor scram prior to exceed in the LSSS. The LN recorders are over 20 years old, with aging components having a greater probability of failures. The new recorders with new components will have no such component age related issues, thereby improving reliability compared to the aging components of the existing recorders. In addition to factory quality assurance testing, the new recorders have been thoroughly calibrated and tested for functionality on site. Technical specifications (TS 4.2.1&2) require channel checks and tests prior to each day's operation.

- 3: Will the chart recorder replacement result in more than a minimal increase in the consequences of an accident previously evaluated in the FSAR?

No.

Accident analyses assume automatic protective systems are operable (NUREG 1537). The FSAR analyses for coolant flow loss and reactivity addition show there is no consequence for either if the scram occurs at the LSS or at a more conservative value. The recorders replacement will have no effect on the accident consequence or lack thereof.

- 4: Will the chart recorder replacement result in more than a minimal increase in the consequences of a malfunction of an SSC important to safety previously evaluated in the FSAR?

No.

Malfunctions of SSC resulting in a radiological consequence are not analyzed in the FSAR. For the UMLRR, the consequences of an SSC malfunction would be bounded by the accident consequences evaluated in the FSAR. Except for the MHA, all the accident analyses show there is no consequence.

- 5: Will the chart recorder replacement create a possibility for an accident of a different type than any previously evaluated in the FSAR?

No.

All credible accident scenarios have been evaluated in the UMLRR FSAR. There are no credible accidents associated with the chart recorders that would not be bounded by the accident scenarios in FSAR, including the MHA.

- 6: Will the chart recorder replacement create a possibility for a malfunction of an SSC important to safety with a different result than any previously evaluated in the FSAR?

No.

The results of some equipment malfunctions (e.g., loss of primary pump) have been evaluated in the FSAR, though none were analyzed for the temperature and coolant flow chart recorders. Nonetheless, the possible results of a chart recorder failure using the old recorders would be the same for the new recorders.

- 7: Will the chart recorder replacement result in a design basis limit for a fission product barrier as described in the FSAR being exceeded or altered?

No.

As analyzed in the FSAR, there are no reactor transients or credible accidents that pose a significant risk of fuel cladding failure. The UMLRR design basis limit for the primary fission product barrier (fuel cladding) is the onset of nucleate boiling (ONB). The temperature for ONB is well below that for fuel cladding failure and the UMLRR Technical Specifications limiting safety system settings (LSSS) assure that the ONB is not reached. The measurement resolution of the new recorders is better than the old recorders. The calibration of each has shown the recorders to be accurate over their intended range of use. The use of the new chart recorders will not result in a design basis limit for a fission product barrier as described in the FSAR being exceeded or altered.

- 8: Will the chart recorder replacement result in a departure from a method of evaluation described in the FSAR used in establishing the design bases or in the safety analyses?

No.

The installation and use of the new chart recorders will not involve a change to any analytical method used in the safety analyses provided in the FSAR.

#### DETERMINATION CONCLUSION:

The chart recorders replacement does not involve a modification of the Technical Specifications and meets the criteria specified in 10 CFR 50.59. As such, it may be implemented without prior NRC approval in accordance with 10 CFR 50.59.



**10CFR 50.59  
Screenings and  
Evaluations  
Screen Form**

Form No.: AP-6-1  
Revision: 0  
Date Issued: 12/16/09  
Page 1 of 4

**50.59 SCREEN**

**Activity Screening Number:**

**Title:**

**Description of Activity (what is being changed and why):**

The intermediate range log scale reactor power measuring channel installed in 1997 will be replaced with a new wide range logarithmic power amplifier. The existing unit and the new unit are both manufactured by General Atomics. A complete description is attached.

**50.59 Screening Questions:** (SSC = structure, system, or component)

1. Does the proposed activity adversely affect an SSC design function described in the FSAR?  
 YES  NO
2. Does the proposed activity adversely affect a method of performing or controlling an SSC design function described in the FSAR?  YES  NO
3. Does the proposed activity involve revising or replacing a FSAR described evaluation methodology that is used in establishing the design bases or used in the safety analyses?  YES  NO
4. Does the proposed activity involve a test or experiment not described in the FSAR, where an SSC is utilized or controlled in a manner that is outside the reference bounds of the design for that SSC or is inconsistent with analyses or descriptions in the FSAR?  YES  NO
5. Does the proposed activity require a change to the UMLRR Tech Specs?  YES  NO

If all screening questions are answered NO, then implement the activity per the applicable approved facility procedure(s). A License Amendment or a 50.59 Evaluation is not required.

If Screen Question 5 is answered YES, then request and receive a License Amendment prior to implementation of the activity.

If Screen Question 5 is answered NO and Question 1, 2, 3, or 4 is answered YES, then complete and attach a 50.59 Evaluation form. [Refer to Attachment 2]

**NOTE:** If the conclusion of the screening question is that a 50.59 Evaluation is not required, provide a justification for the "No" determination. In addition, list the documents (FSAR, Technical Specifications, and other Licensing Basis documents) reviewed where relevant information was found. Include section / page numbers. Use page 2 of this form to document your statements.

	Print Name	Sign Name	Date
<b>Preparer (SRO):</b>			
<b>Reactor Supervisor</b>	<i>R. J. Sordick</i>	<i>R. J. Sordick</i>	<i>12/18/13</i>

	<b>10CFR 50.59</b> <b>Screenings and</b> <b>Evaluations</b>  <b>Screen Form</b>	Form No.: AP-6-I Revision: 0 Date Issued: 12/16/09 Page 2 of 4
--	---	---

**50.59 SCREEN (Cont.)**

Screen No. 13-02

If the conclusion of the five (5) Screening Questions is that a 50.59 Evaluation is not required, provide justification to support this determination: *[Use and attach additional pages as necessary.]*

1. Does the proposed activity adversely affect an SSC *design function* described in the FSAR?

No. The Log-N intermediate channel is described in FSAR 4.3.2. The function of the Log-N channel is to monitor the reactor power level and differentiate the Log-N signal to provide the reactor period. The new channel is designed to provide the same function, only over a wider range of neutron flux.

2. Does the proposed activity adversely affect a method of performing or controlling an SSC *design function* described in the FSAR?

No. The purpose of the Log-N channel is to provide a measure of the reactor power on a logarithmic scale and to measure the rate of change (reactor period). In addition, the channel provides two automatic safety functions – 1) a relay and electronic scram for a short period; 2) a control rod inhibit for a short period. Both functions are provided by the new channel. In addition, the new channel also provides a high power scram.

3. Does the proposed activity involve revising or replacing an evaluation methodology that is used in *establishing a design bases* or used in a *safety analyses* described in the FSAR?

An automatic shutdown due to either power or reactor period is considered for the safety analysis associated with a step reactivity insertion. The response time of the Log-N circuit is <1msec at the high power end of the range. This is well within the 100msec used for initiation of the scram used in the safety analysis transient calculations.

4. Does the proposed activity involve a *test or experiment not described in the FSAR*, where an SSC is used or controlled in a manner that is outside the reference bounds of the design for that SSC, or is inconsistent with analyses or descriptions presented in the FSAR?

No. The change does not involve a test or experiment as defined for 50.59 evaluation purposes.

List the documents (FSAR, Technical Specifications, and SER) reviewed where relevant information was found (include section / page numbers).

Technical Specification – 3.2, 3.3  
FSAR 4.4.13 – Intermediate Channel  
SER – 7.2.1 (2) Log-N Power Channel  
FSAR – 9.1.10 Step Increase in Reactivity

End of Screen

	<b>10CFR 50.59</b> <b>Screenings and</b> <b>Evaluations</b>  <b>Screen Form</b>	Form No.: AP-6-1 Revision: 0 Date Issued: 12/16/09 Page 3 of 4
--	---	---

### Description of Change

The log scale reactor power measuring channel installed in 1997 will be replaced with a new wide range logarithmic power amplifier. The existing unit and the new unit are both manufactured by General Atomics (GA).

The presently used GA model NLI-1000 is an intermediate range power measuring channel. The channel provides an indication of the reactor power, the reactor period, and the detector high-voltage. An operational amplifier provides logarithmic measure of the reactor power over a 7 decade scale. When coupled to a suitable detector (compensated ion chamber), the channel is designed to measure neutron levels from  $3E2$  nv to  $3E9$  nv. To measure the rate of power change, the reactor period is derived by an operational amplifier and circuits that differentiate the log power signal. The channel includes electronic and relay trip circuits to provide alarm and scram signals for power, detector high voltage and reactor period.

The replacement GA model NLW-1000 wide-range log channel combines the functions of logarithmic counting and logarithmic current conversion to provide an indication of reactor power from source level to full power. The NLW-1000 utilizes both pulse counting and current mode to provide a logarithmic indication of power. The pulse counting provides for three additional low end ranges not currently available in the NLI-1000. The addition of the three decades of range will provide the capability for monitoring reactor power/period from the source level to criticality. Similar to the NLI-1000, the channel provides an indication of the reactor power, the reactor period, and the detector high-voltage. The balance of the NLW-1000 functions will be identical to that of the NLI-1000 that it is replacing. The channel includes electronic and relay trip circuits to provide alarm and scram signals for power, detector high voltage and reactor period.

The table below lists the specifications for both systems allows for a comparison of the two systems capability to perform the intended safety and measurement functions.

<u>SPECIFICATION</u>	<u>NLI-1000</u>	<u>NLW-1000</u>
Current	1E-10 to 1E-3 amps (7 decades)	counting and current 0.1cps to >3e6CPS 1E-6 to 1E-3 amps (10 decades)
Linearity	+/- 3% at full scale	+/-2% at full scale
Temp Coefficient	+/-0.15% per °C 10°- 55°	+/-0.15% per °C 10°- 55°
Response Time	1E-4 to 1E-3 Amp < 1 mSec	1E-4 to 1E-3 Amp < 1 mSec.
Range	-30 to 3 s (period) 1E-5 to 100% (power)	-30 to 3 s (period) 1E-8 to 100% (power)
Neutron Flux Range	$3E2$ nv to $3E9$ nv	0.3 nv to $1E10$ nv

The major difference between the units is the detector types that each utilize. The NLI-1000 utilizes the same compensated ion chamber as the two linear channels use, while the NLW-1000 utilizes a



 <p>University of Massachusetts UMASS Lowell Research Reactor</p>	<p><b>10CFR 50.59</b> <b>Screenings and</b> <b>Evaluations</b></p> <p><b>Screen Form</b></p>	<p>Form No.: AP-6-1 Revision: 0 Date Issued: 12/16/09 Page 4 of 4</p>
---	--	---

U-235 fission chamber. The fission chamber is a GA product that contains an aluminum encased Mirion/IST WL-6376A fission chamber containing 1.81 g of U with 1.68 g of U-235. The NLW-1000 also utilizes a PA-1000 pre-amplifier for conditioning the fission chamber signals. Similar to the preamplifier for the Start-up proportional counter, the fission chamber pre-amplifier will be located at the reactor bridge.

Because the fission chamber contains 1.68g U-235, the fission chamber will be listed under the Special Nuclear Material License for the UMass until the reactor license is either amended or renewed.

**50.59 SCREEN**

**Activity Screening Number:**

**Title:**

**Description of Activity** *(what is being changed and why):*

See attached summary.

**50.59 Screening Questions:**

1. Does the proposed activity adversely affect an SSC design function described in the FSAR?  
 YES  NO
2. Does the proposed activity adversely affect a method of performing or controlling an SSC design function described in the FSAR?  YES  NO
3. Does the proposed activity involve revising or replacing a FSAR described evaluation methodology that is used in establishing the design bases or used in the safety analyses?  YES  NO
4. Does the proposed activity involve a test or experiment not described in the FSAR, where an SSC is utilized or controlled in a manner that is outside the reference bounds of the design for that SSC or is inconsistent with analyses or descriptions in the FSAR?  YES  NO
5. Does the proposed activity require a change to the UMLRR Tech Specs?  YES  NO

If all screening questions are answered NO, then implement the activity per the applicable approved facility procedure(s). A License Amendment or a 50.59 Evaluation is not required.

If Screen Question 5 is answered YES, then request and receive a License Amendment prior to implementation of the activity.

If Screen Question 5 is answered NO and Question 1, 2, 3, or 4 is answered YES, then complete and attach a 50.59 Evaluation form. [Refer to Attachment 2]

**NOTE:** If the conclusion of the screening question is that a 50.59 Evaluation is not required, provide a justification for the "No" determination. In addition, list the documents (FSAR, Technical Specifications, and other Licensing Basis documents) reviewed where relevant information was found. Include section / page numbers. Use page 2 of this form to document your statements.

	Print Name	Sign Name	Date
<b>Preparer (SRO):</b>			
<b>Reactor Supervisor</b>	<i>A. B. B. B.</i>	<i>[Signature]</i>	<i>10/6/14</i>

**50.59 SCREEN (Cont.)**

Screen No.

If the conclusion of the five (5) Screening Questions is that a 50.59 Evaluation is not required, provide justification to support this determination: *[Use and attach additional pages as necessary.]*

1. Does the proposed activity adversely affect an SSC *design function* described in the FSAR?

No. The panel meters provide an additional point of measurement for these variables in the control room and augment upgrades made in 2001. Temperature and flow measurement is described in the FSAR as accomplished by the use of chart recorders (FSAR Table 4.5, FSAR 4.4.17.3 and 4.4.17.5). The chart recorders, in addition to the process controls upgrades in 2001 are unchanged.

2. Does the proposed activity adversely affect a method of performing or controlling an SSC *design function* described in the FSAR?

No. The installation of the panel meters provides redundancy and diversity for both the measurement display and the trip functions while maintaining the SSC currently in place.

3. Does the proposed activity involve revising or replacing an evaluation methodology that is used in establishing a *design bases* or used in a *safety analyses* described in the FSAR?

No. The applicable design bases evaluation methodologies for the flow, temperature, and pool height variables remain unchanged. The accuracy and resolution of the new indicators (as well as the existing SSC) are within the values used for the safety analyses.

4. Does the proposed activity involve a *test or experiment not described in the FSAR*, where an SSC is used or controlled in a manner that is outside the reference bounds of the design for that SSC, or is inconsistent with analyses or descriptions presented in the FSAR?

No. The addition of panel meters does not involve a test or experiment such that the existing SSC (or new indicators) would be used in manner that could exceed limiting conditions of operation, or limiting safety system values, and is consistent with the analyses and descriptions in the FSAR.

List the documents (FSAR, Technical Specifications, and SER) reviewed where relevant information was found (include section / page numbers).

FSAR 4.4.17.3&5, FSAR 9.0, LEU Supplement 3.0, TS 2.2.1, and SER 7.2.24.1.7

End of Screen

50.59 Screen 14-01  
Addition of Indicator Display Panel  
October 7, 2014

Activity Summary

An indicator display panel has been installed in available space located on the upper left quadrant of the control room instrumentation cabinet. The panel includes indicators for primary flow rate, core flow rate, primary temperatures (pool, inlet, & outlet) and pool height. The purpose is to provide greater redundancy and diversity for the display of these process variables.

The panel indicators are the Tracker 220 series manufactured by Data Track Process Instruments. Each meter is approximately 3.5-in. wide and 2-in. high with bright, seven segment red LED, 5 digit, 0.56" numeral indicators. The location of the panel and size of the indicators make it convenient for the operator to observe the readings when seated at the control console (attached figure). In addition to the parameter display, each indicator provides output relays for use in alarm and scram functions. The panel is designed with a test function capability for each indicator to introduce test signals for functional testing of the indicator response and relay actions.

Purpose

Prior to 2001, the reactor operator would observe temperature and flow data by checking the chart recorders and then recording the temperature and flow data on a log sheet once per hour during reactor operation. There was no indication of pool height, other than an alarm and scram signal if a decrease in pool level was detected by a mechanical float switch. The core flow rate indication was provided by a small display meter on the instrument panel that would also be checked once per hour.

In 2001, the variables displayed on the chart recorders (primary coolant temperatures and flow rate) also became available on the digital graphical user displays as part of the process control system upgrade (PCS) at that time. Additional capability was added to provide indications of pool height and core flow rate. These displays allow the operator to observe the data from all the process variables in real time at the control console. Procedurally, the operator is still required to record data for these and other variables each when the reactor is operating. The PCS was designed with a redundant display should the console display fail. The PCS uses a single processor in the data acquisition system and if this processor were to fail, the temperature and flow data would be unavailable on the displays. However, the data still would be available on the recorders as had been prior to the 2001 upgrade. The addition of the new indicator panel enhances the redundancy and diversity of observable data for the operator.

In addition to providing data display redundancy, the meters also provide relay outputs for redundant and diverse alarm and scram outputs that augment the existing alarm and scram outputs associated with the chart recorders.

#### Quality Assurance and Testing

The panel indicators are manufactured under ISO9001 compliance. The panel has been fabricated and installed by CES, Inc. CES recently fabricated and installed a similar panel with the same indicators at the 2MW RINSC reactor to monitor the reactor coolant flow rate and coolant temperature process variables and to provide alarm and scram trip functions. In communications, RINSC personnel, there have been no problems with the use or functionality of their panel or indicators.

The resolution of the flow indicator is calculated to be 0.5 GPM based on a maximum 2000 GPM flow at a 20mA measured transducer output and a stated resolution of 0.5uA. The accuracy is stated as 0.05% of the reading which is equivalent to 1GPM at a maximum 2000 GPM reading. The resolution of the temperature indicator for a type-Pt100 RTD is stated as 0.5<sup>o</sup>C (~0.9<sup>o</sup>F). The resolution and accuracy of the indicators is within that referenced in calibration procedures, +/- 40GPM and +/- 1.5<sup>o</sup>F. For the pool height indicator, the accuracy is calculated to be ~0.15 inch with a resolution of ~0.07 inch based on the stated accuracy and resolution. The allowable calibration tolerance from the calibration procedure is 0.5 inch.

The indicators were bench tested and checked for signal response using the panel mounted test signal generators. Following installation, the indicators were calibrated using the existing RTDs for the primary coolant, and the existing flow sensors for the primary coolant. Pool height is measured a standard tape measurer from the top of the pool. The calibration procedures used for these checks are: CP-4 Calibration of Temperature Monitor Devices, CP-5 Calibration of Flow Measuring Devices, and CP-6 Calibration of Pool Level Sensors. Each calibration has shown the indicators to be accurate over their intended range of use and the calibration data has been placed on file. Very minor changes are needed for these procedures. In both instances, the steps for the calibration checks remain the same. Minor changes to the reactor checkout procedure will be made to reflect minor changes to how the temperature and flow trips for these indicators are checked prior to start-up. All licensed operators will be trained on the use of the new indicators.

New panel indicators mounted in the instrumentation cabinet.



**Screen Form**

**50.59 SCREEN**

**Activity Screening Number:**

14-02

**Title:**

Linear Channel 1&2 Amplifier/Trip Module Replacement

**Description of Activity** (*what is being changed and why*):

The two existing General Atomics wide-range linear power measuring amplifiers installed in 1997 will be replaced with new General Atomics linear wide-range linear power measuring amplifiers.

**50.59 Screening Questions:** (SSC = structure, system, or component)

1. Does the proposed activity adversely affect an SSC design function described in the FSAR?

YES  NO

2. Does the proposed activity adversely affect a method of performing or controlling an SSC design function described in the FSAR?

YES  NO

3. Does the proposed activity involve revising or replacing a FSAR described evaluation methodology that is used in establishing the design bases or used in the safety analyses?

YES  NO

4. Does the proposed activity involve a test or experiment not described in the FSAR, where an SSC is utilized or controlled in a manner that is outside the reference bounds of the design for that SSC or is inconsistent with analyses or descriptions in the FSAR?

YES  NO

5. Does the proposed activity require a change to the UMLRR Tech Specs?

YES  NO

If all screening questions are answered NO, then implement the activity per the applicable approved facility procedure(s). A License Amendment or a 50.59 Evaluation is not required.

If Screen Question 5 is answered YES, then request and receive a License Amendment prior to implementation of the activity.

If Screen Question 5 is answered NO and Question 1, 2, 3, or 4 is answered YES, then complete and attach a 50.59 Evaluation form. [Refer to Attachment 2]

**NOTE:** If the conclusion of the screening question is that a 50.59 Evaluation is not required, provide a justification for the "No" determination. In addition, list the documents (FSAR, Technical Specifications, and other Licensing Basis documents) reviewed where relevant information was found. Include section / page numbers. Use page 2 of this form to document your statements.

	Print Name	Sign Name	Date
<b>Preparer (SRO):</b>			
<b>Reactor Supervisor</b>	<i>L. P. Felt</i>	<i>[Signature]</i>	12/17/14

**50.59 SCREEN (Cont.)**

Screen No.

If the conclusion of the five (5) Screening Questions is that a 50.59 Evaluation is not required, provide justification to support this determination: *[Use and attach additional pages as necessary.]*

1. Does the proposed activity adversely affect an SSC *design function* described in the FSAR?

No. The linear power channel is described in FSAR 4.4.14. The channel consists of a neutron detector, current amplifier/trip module, and power level indicator. The *design function* of the linear channel is to measure neutron fluence (power level) in ranges that overlap the start-up channel and cover the logarithmic power measuring channel. It also provides multiple trip functions for alarm and scrams. The new amplifier/trip module provides identical functionality to existing unit.

2. Does the proposed activity adversely affect a method of performing or controlling an SSC *design function* described in the FSAR?

No. The existing linear power module provides the reactor power measurement on a linear scale (0 to 120%), for a given decade range. The range either may be selected manually or automatically. The module provides the percent power indication on the front panel of the unit and provides output signals to a remote meter and chart recorder. The module provides automatic trip functions – relays for alarm and scram, and an opto-isolator for a logic scram. The same functionality is provided by the new module.

3. Does the proposed activity involve revising or replacing an evaluation methodology that is used in establishing a *design bases* or used in a *safety analyses* described in the FSAR?

An automatic shutdown due to either power or reactor period is considered for the safety analysis associated with a step reactivity insertion. The response time for the linear power measuring circuit is 1msec at the high power end of the range. This is well within the 100msec used for initiation of the scram used in the safety analysis transient calculations.

4. Does the proposed activity involve a *test or experiment not described in the FSAR*, where an SSC is used or controlled in a manner that is outside the reference bounds of the design for that SSC, or is inconsistent with analyses or descriptions presented in the FSAR?

No. The change does not involve a test or experiment as defined for 50.59 evaluation purposes.

List the documents (FSAR, Technical Specifications, and SER) reviewed where relevant information was found (include section / page numbers).

Technical Specification – 3.2, 3.3  
FSAR 4.4.14 – Flux Level Safety Channel  
SER – 7.2.1 (3) Safety Channels  
FSAR – 9.1.10 Step Increase in Reactivity

End of Screen



### **NMP-1000 Description and Comparisons**

The NMP-1000 is a wide-range linear amplifier and trip module designed for an accurate measurement and display of reactor power and detector high voltage. A description of the functional components of the unit (pictured below) is provided.



#### Amplifier Circuit Board

An analog amplifier circuit board measures the incoming current signal from the neutron detector (compensated ion chamber) and converts it into a linear analog voltage in nine one-decade ranges. For every decade of current, the analog board returns a 0 to +10VDC signal. Since the NMP is designed to measure power up to 120% of nominal, an output voltage of +10VDC represents 1.2 x nominal current. The detector current is accurately measured from 10pA to 1.2mA using a high input impedance operational amplifier. For every decade of current, a relay switches in the appropriate feedback resistor to generate the expected output signal. The 1E-11 decade is the default range and always active. Other ranges are switched into the circuit in parallel as determined by a microprocessor.

### Trip Alarm Circuit Board

The trip/alarm circuit board contains six identical circuits to generate all the trip and alarm indications. Each circuit is jumper configurable for a rising or falling trip. A comparator monitors an incoming signal voltage from the amplifier circuit board and compares it to a reference voltage. The reference voltage (trip set-point) is user adjustable via a potentiometer. When the circuit is configured for a rising trip, the comparator will switch states when the amplitude of the incoming signal exceeds the reference signal. A falling trip works the opposite way; when the incoming signal amplitude falls below the reference voltage, the comparator will switch states. Once a trip has occurred, the circuit latches in the tripped state. The only way to unlatch the circuit is for the user to apply a reset signal, even if all signal levels return to nominal prior to the reset. Each trip has both a DPDT (Form C) relay and an opto-isolator providing a trip logic signal that can be connect to via remote connectors on the unit. The relay is controlled by the output of the comparator and the operate signal. Taking the NMP out of operate mode (such as during a self-test) will immediately activate the trip relay.

### Isolation Amplifier Board

The isolation amplifier board houses two isolated outputs that can be jumper configured for either voltage or current output. The isolators are commercially available programmable voltage to current converters. The converters provide 1500Vrms galvanic isolation. Adjustment potentiometers allow the isolators to be calibrated for offset and span. A 0 to +10VDC input will generate a 4 to 20mA or 0 to +10VDC output that is available to the user via the remote connectors on the unit.

### Display and Front Panel

The display on the front of the module is a Monochrome LCD Display with white LED backlight. The display has a viewing area of 3.8 inches (diagonal) and a resolution of 320 X 240 (QVGA). The display includes an integrated touch panel and integrated digital backlight & contrast controls. A complete graphical operating system that executes GUI applications built in dynamic HTML is included with the display. The front panel board houses the red LED indicators for all trips, activated by the trip/alarm board. A potentiometer lets the user

**Screen Form**

manually control the current in test mode. This potentiometer is accessible with a knob on the front panel. Two recessed potentiometers allow the user adjust the compensation power supply voltage to the detector.

Specifications Comparison

MODEL NMP-1000 Linear Power Module (EXISTING)

<b>INPUT RANGE</b>	1 x 10 <sup>-10</sup> to 1 x 10 <sup>-3</sup> Amperes or 1 x 10 <sup>-11</sup> to 1 x 10 <sup>-4</sup> Amperes	
<b>LINEARITY</b>	± 1% of Full Scale on upper 5 ranges; ± 2.5% of Full Scale on lower 2 ranges	
<b>TEMPERATURE</b>	± 0.15% / °C maximum in the range of 10° to 55°C	
<b>CALIBRATION/TEST</b>	2 fixed currents for calibration, 1 adjustable for multi-range function test and trip testing. HV trip test.	
<b>RESPONSE TIME</b>	10 <sup>-8</sup> to 10 <sup>-3</sup> Amperes	1 msec
	10 <sup>-9</sup> to 10 <sup>-8</sup> Amperes	10 msec
	10 <sup>-11</sup> to 10 <sup>-9</sup> Amperes	100 msec
<b>BISTABLE TRIPS</b>	High Voltage, High Power and Alarm: User Configurable (increasing or decreasing) Logic Level output and two form "C" contacts per trip	
<b>OUTPUTS</b>	Front Panel	Linear Power (0 to 120%) and range indication High Voltage (0 to 1000 VDC)
	Remote meter	0 -10 VDC or 0-1mA
	Recorder	0 - 1 VDC or 0 - 0.1 VDC or 4-20mA
	High Voltage	300 to 800 VDC @ 2.6 watts
	Compensation	0 to 150 VDC
<b>POWER REQUIRED</b>	117 VAC ± 10% 50/60 Hz @ 1 Amp	

MODEL NMP-1000 Linear Power Module (NEW)

<b>INPUT RANGE</b>	1 x 10 <sup>-11</sup> to 1 x 10 <sup>-3</sup> Amperes	
<b>LINEARITY</b>	± 1% of Full Scale on upper 5 ranges; ± 2.5% of Full Scale on lower 4 ranges	
<b>TEMPERATURE</b>	± 0.15% / °C maximum in the range of 10° to 55°C	
<b>CALIBRATION/TEST</b>	2 fixed currents for calibration, 1 adjustable for multi-range function test and trip testing. HV trip test.	
<b>RESPONSE TIME</b>	10 <sup>-8</sup> to 10 <sup>-3</sup> Amperes	1 msec
	10 <sup>-9</sup> to 10 <sup>-8</sup> Amperes	10 msec
	10 <sup>-11</sup> to 10 <sup>-9</sup> Amperes	100 msec
<b>BISTABLE TRIPS</b>	High Voltage, High Power and Alarm: User Configurable (increasing or decreasing) Logic Level output and two form "C" contacts per trip	
<b>OUTPUTS</b>	Front Panel	Linear Power (0 to 120%) and range indication High Voltage (0 to 1000 VDC)
	Remote meter/recorder	Two configurable @ 0-10 VDC or 4-20mA
	High Voltage	300 to 800 VDC @ 2.6 watts
	Compensation	0 to 150 VDC
<b>POWER REQUIRED</b>	117 VAC ± 10% 50/60 Hz @ 1 Amp	

END

**Screen Form**

**50.59 SCREEN**

**Activity Screening Number:**

**Title:**

**Description of Activity (what is being changed and why):**

The control room annunciator panel is being replaced. The existing panel is the original installed in 1974. The original alarm panel has 17 individual alarm indicators (2"x3" each), each illuminated by two 120VAC incandescent light bulbs. The new panel will have indicators (2.25"x2.75" each), each illuminated by multiple LEDs. 6 additional alarm indicators have added to provide additional information for the operator.

**50.59 Screening Questions:** (SSC = structure, system, or component)

1. Does the proposed activity adversely affect an SSC design function described in the FSAR?  
 YES  NO
2. Does the proposed activity adversely affect a method of performing or controlling an SSC design function described in the FSAR?  YES  NO
3. Does the proposed activity involve revising or replacing a FSAR described evaluation methodology that is used in establishing the design bases or used in the safety analyses?  YES  NO
4. Does the proposed activity involve a test or experiment not described in the FSAR, where an SSC is utilized or controlled in a manner that is outside the reference bounds of the design for that SSC or is inconsistent with analyses or descriptions in the FSAR?  YES  NO
5. Does the proposed activity require a change to the UMLRR Tech Specs?  YES  NO

If all screening questions are answered NO, then implement the activity per the applicable approved facility procedure(s). A License Amendment or a 50.59 Evaluation is not required.

If Screen Question 5 is answered YES, then request and receive a License Amendment prior to implementation of the activity.

If Screen Question 5 is answered NO and Question 1, 2, 3, or 4 is answered YES, then complete and attach a 50.59 Evaluation form. [Refer to Attachment 2]

**NOTE:** If the conclusion of the screening question is that a 50.59 Evaluation is not required, provide a justification for the "No" determination. In addition, list the documents (FSAR, Technical Specifications, and other Licensing Basis documents) reviewed where relevant information was found. Include section / page numbers. Use page 2 of this form to document your statements.

	<b>Print Name</b>	<b>Sign Name</b>	<b>Date</b>
<b>Preparer (SRO):</b>			
<b>Reactor Supervisor</b>	<i>R. J. B. ELL</i>	<i>[Signature]</i>	<i>3/23/16</i>

**50.59 SCREEN (Cont.)**

Screen No.

If the conclusion of the five (5) Screening Questions is that a 50.59 Evaluation is not required, provide justification to support this determination: *[Use and attach additional pages as necessary.]*

1. Does the proposed activity adversely affect an SSC *design function* described in the FSAR?

No. The original alarm was panel was designed to provide a visible and audible annunciation of an alarm condition to the operator. The new alarm panel will perform the same function. The audible indicator (alarm buzzer) is not being changed, only the visible alarm indicators. The new indicators will use more reliable LED technology rather than incandescent lights. The indicators are slightly larger and will be in the same physical location in the control room.

2. Does the proposed activity adversely affect a method of performing or controlling an SSC *design function* described in the FSAR?

No. The audible and visible alarm indicators are triggered by relays and switches. For example, the "Short Period" alarm is triggered by a relay in the Logarithmic Power/Period module. The alarm triggers are not being changed, only the indicators.

3. Does the proposed activity involve revising or replacing an evaluation methodology that is used in establishing a *design bases* or used in a *safety analyses* described in the FSAR?

No. The proposed activity is not associated with or applicable to evaluation methodologies in the FSAR.

4. Does the proposed activity involve a *test or experiment not described in the FSAR*, where an SSC is used or controlled in a manner that is outside the reference bounds of the design for that SSC, or is inconsistent with analyses or descriptions presented in the FSAR?

No. The change does not involve a test or experiment as defined for 50.59 evaluation purposes.

List the documents (FSAR, Technical Specifications, and SER) reviewed where relevant information was found (include section / page numbers).

FSAR Table 4.3 (pg 4-54), Table 4.4 (pg 4-72)  
FSAR 4.4.16 Alarm and Indicator System

End of Screen

### **Existing FSAR Description**

#### 4.4.16 Alarm and Indicator System (Table 4.4)

The alarm system is divided into two sections: one for coolant variables and the other for nuclear variables. The section used for cooling system alarm will be operative with forced cooling. When an abnormal condition develops, a buzzer sounds and the appropriate light goes on. The operator may press the acknowledge button to silence the buzzer. When the alarm condition is corrected, the light may be reset. The following conditions will actuate the alarm system:

- (1) Short period inhibit
- (2) High neutron flux inhibit
- (3) Safety chain scram
- (4) Blade disengaged
- (5) Low pool level
- (6) Bridge unlocked
- (7) Access doors open
- (8) Coolant gates open
- (9) Seismic trip
- (10) Low coolant flow (2 sensors)
- (11) High coolant temperature (3 sensors)
- (12) High conductivity
- (13) High voltage failure
- (14) Regulating blade at limit
- (15) Reactor core low flow
- (16) Demineralizer high temperature and low flow.

#### **Changes to FSAR Description**

No change to the FSAR description is required, with the exception of listing the additional alarm indicators. The additional indicators will be listed as follows:

- (17) Building Pressure
- (18) Low Secondary Flow
- (19) Pump Room Sump
- (20) PH Limit
- (21) Natural Convection Mode
- (22) (#16 above has been changed to provide two separate indicators)

Appendix C

RAI Response 7.6

Draft NMP1000 Installation Plan

Draft NMP1000 Test and Calibration Procedure

 <p>University of Massachusetts Lowell Research Reactor</p>	<b>GEN2 NMP-1000 LINEAR POWER CHANNEL INSTALLATION PLAN</b>	Revision: 0 Date Issued: _____ Page 1 of 9
---	---	--

## 1.0 Purpose and Scope

This Linear Power Channel Installation Plan provides guidance on the installation and testing of the Gen 2 General Atomics NMP-1000 Multi-Range Linear Power module. The Gen 2 module will replace the Gen 1 NMP-1000 module installed in 1997. The purpose of this plan is to assure the new unit performs the functions as described in the license Technical Specifications and the Final Safety Analysis Report.

**NOTE:** The guidance provided in this document may vary in accordance with actual circumstances during the testing and installation process.

## 2.0 References

Technical Specification – 3.2, 3.3  
FSAR 4.4.14 – Flux Level Safety Channel  
SER – 7.2.1 (3) Safety Channels  
General Atomics NMP-1000 User Manual

## 3.0 Pre-installation Tests

### STARTUP

- a. Set the power switch on the Power connector on the rear panel to the ON position.
- b. Set the **REMOTE CONTROL** button switch to Local Mode by depressing/engaging.
- c. Verify the green LED is extinguished.
- d. Verify the NMP-1000 LCD displays the MAIN MENU Display.
- e. Ensure all trip and the High Voltage indicators are extinguished. Press **Trip Reset** on MAIN MENU if necessary, to clear any trips.

### NORMAL OPERATION (FORCED CONVECTION MODE)

- a. On the Front Panel, ensure the **REMOTE CONTROL** button switch is depress/engaged.
- b. Verify that the green LED is extinguished to indicate that the module is in Local Mode.
- c. On the Front Panel, turn the **Manual Current Adjust** potentiometer to full CCW.
- d. On the LCD press the **Gain** button. In the Gain menu Display, press the **Auto** button.
- e. On LCD press the **Test/Cal** button. In the Test/Cal menu Display, press the **Operate** button.



 <p>University of Massachusetts <b>UMASS</b> Lowell Research Reactor</p>	<p><b>GEN2 NMP-1000 LINEAR POWER CHANNEL INSTALLATION PLAN</b></p>	<p>Revision: 0 Date Issued: _____ Page 2 of 9</p>
--	--	---

f. Ensure all the trips on the front panel are extinguished.

Select the **Test/Cal** button and perform the following tests:

Calibrate High Test

- a. Press **Calibrate High**.
- b. Verify Trip 1 LED illuminates.
- c. Verify Trip 2 LED illuminates.
- d. In the Test/Calibration Menu press the select the **Main** button.

Verify that the output reading is 120% of the 1E-4 scale

Allow for NMP to automatically return to **Operate** mode (approx. 1 minute), and return to Main Menu. To reset the trips, press **Trip Reset**.

Calibrate Low Test

- a. Press **Calibrate Low**, and return to **Main Menu**.
- b. Verify that no trips occur and that approximately 19% power is indicated.

Allow for NMP to automatically return to **Operate** mode (approx. 1 minute), and return to Main Menu.

Verify that the Gain is set to Auto on the **Gain Menu** Display.

- a. Turn the **MANUAL CURRENT ADJUST** potentiometer on the front panel fully counter clockwise (CCW).
- b. Select the Test Current button on the TEST/CAL MENU Display.
- c. Observe the Gain Range on the TEST/CAL Menu Display.
- d. Slowly start turning the **MANUAL CURRENT ADJUST** potentiometer on the front panel clockwise (CW).
- e. As the potentiometer is turned CW, observe the Gain Range change from 10E-11 to 10E-3 over the range of the potentiometer.
- f. Allow for NMP to automatically return to **Operate** mode (approx. 1 minute), and return to **Main Menu** and ensure **MANUAL CURRENT ADJUST** potentiometer on the front panel fully counter clockwise (CCW).

HV Test

Go to the **Test/Cal Menu**

 <p>University of Massachusetts <b>UMASS</b> Lowell Research Reactor</p>	<p><b>GEN2 NMP-1000 LINEAR POWER CHANNEL INSTALLATION PLAN</b></p>	<p>Revision: 0 Date Issued: _____ Page 3 of 9</p>
--	--	---

- a. Press **HV Test**.
- b. Verify High Voltage Trip LED illuminates on front face of unit.
- c. In the **Test/Cal Menu**, press the **Operate** button.
- d. To reset the trips, select Main Menu and press Trip Reset.

#### High Voltage Calibration

- a. Monitor the output voltage of the HV power supply on rear panel connector J2 with a DMM capable of reading up to 1000VDC.
- b. Vary R4 on the motherboard and verify that the power supply produces between 300 and 1000VDC.
- c. Set the power supply output for 800VDC with R4.
- d. Verify the HV value on the **MAIN MENU** Display is  $800V \pm 12V$ .

#### Unit Calibrations

- a. Remove the cover from the NMP-1000
- b. Connect the AC power cord to the NMP-1000 and plug it in, but do not turn on the power.
- c. Connect the current source to J1 on the NMP-1000.
- d. Set the following dip switch settings (S1) on the Digital Interface Board.
- e. Verify that the J9 connector cable is not in place between the DIB and J9 port.

Switch	Purpose	Setting
1	Static IP address Selection (bit #0)	Note 1
2	Static IP address Selection (bit #1)	Note 1
3	Static IP address Selection (bit #2)	Note 1
4	Reserved for module-specific purposes	ON
5	Ethernet multiple connection enabled	OFF
6	COM port control bit # 0	ON
7	COM port control bit # 1	OFF
8	Test mode enabled	ON

### High Voltage Calibration

- a. Monitor the output voltage of the HV power supply on rear panel connector J2 with a DMM capable of reading up to 1000VDC.
- b. Vary R4 on the motherboard and verify that the power supply produces between 300 and 1000VDC.
- c. Set the power supply output for 800VDC with R4.
- d. Verify the HV value on the MAIN MENU Display is  $800V \pm 12V$ .

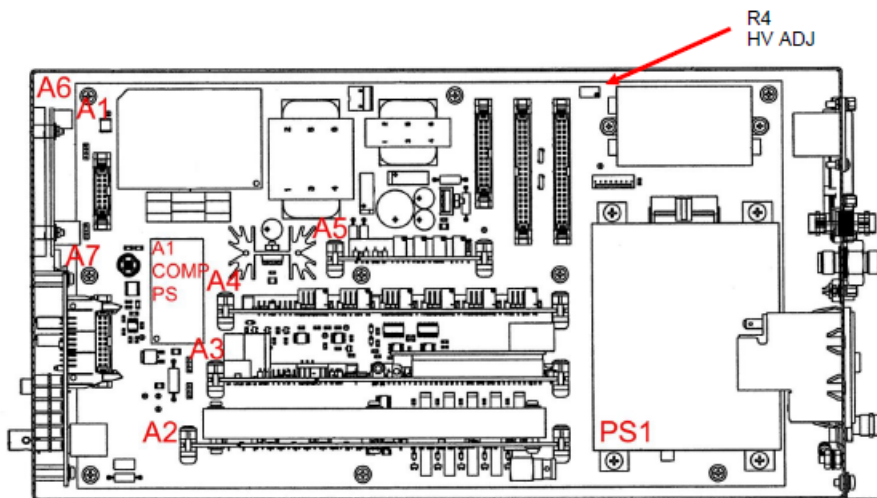

### Auto-Range Setpoints

- a. Set the current on the current source to 0  $\mu$ A.
- b. Clear all trips by pressing TRIP RESET on front panel display.
- c. Verify that the NMP-1000 is set to local mode by verifying that the green LED adjacent to the button is extinguished.
- d. Select GAIN on the Display, select Auto, then select Main.
- e. Set the current on the current source to 0.1  $\mu$ A. Using steps of 0.1  $\mu$ A, increase current to 0.9  $\mu$ A. Verify that the range is switched to the next higher range at 90% Power.
- f. Using steps of 0.1  $\mu$ A, decrease the current of 0.9  $\mu$ A to 0.1  $\mu$ A. Verify that the range is switched to the next lower range at 8% Power.

#### Calibration of Trips

- a. Verify the Trip/Alarm board jumpers are configured per the following table. Note: If the site jumper configuration is different, record the site configuration so that it can be restored after testing.

Jumper	PINS	Name
JP18	2-3	Trip 1
JP17	2-3	
JP16	N / A	
JP15	2-3	Trip 2
JP14	N / A	
JP13	2-3	
JP12	2-3	HV Trip
JP11	2-3	
JP10	1-2	
JP9	2-3	Trip 4
JP8	2-3	
JP7	1-2	
JP6	1-2	Trip 5 LP - 1
JP5	2-3	
JP4	N/A	
JP3	1-2	Trip 6 LP - 2
JP2	2-3	
JP1	N/A	

R6	R19	R33	R47	R16	R75
Trip 6	Trip 5	Trip 4	Trip 3	Trip 2	Trip 1
SCRAM 2	ALARM 2	(SPARE)	HV TRIP	SCRAM 1	ALARM 1

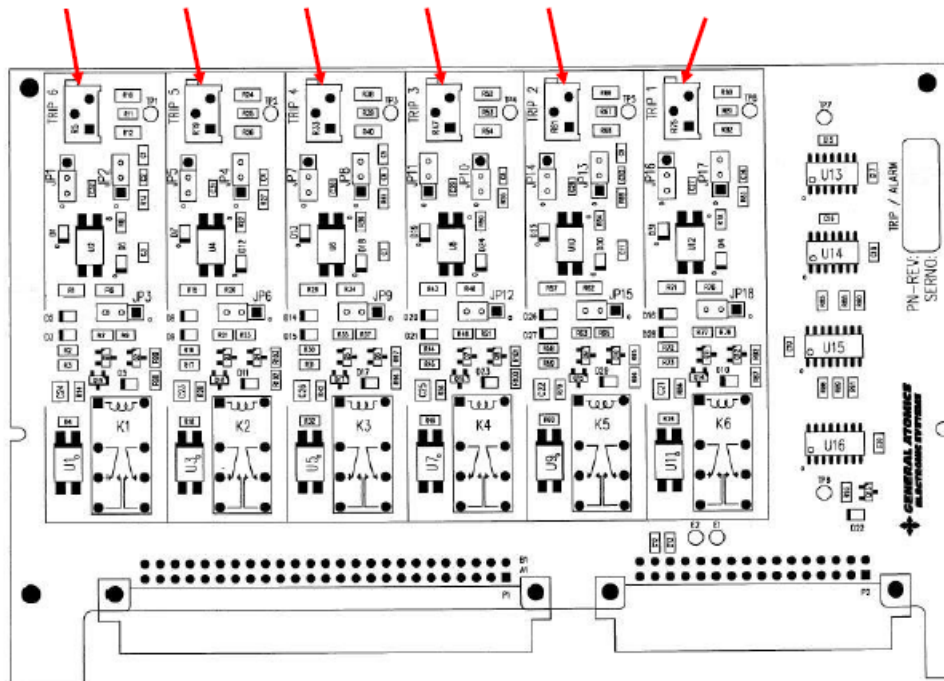

b. Select the Main button on the TEST/CAL MENU Display to enter the MAIN MENU Display.

Note: The HV trip should be set to the setpoint that is determined to be correct of the site. 650 V is used as a setpoint for test purposes.

c. Adjust R4 on the Motherboard until the display displays HV: 650V

d. Turn R75 on the Trip/Alarm board fully CW.

e. Turn R61 on the Trip/Alarm board fully CW.

f. Turn R47 on the Trip/Alarm board fully CCW.

g. Set the current source for an output of 1.1mA.

h. Select the Trip Reset button on the GAIN MENU Display.

i. Observe that all front panel trip indicator LEDs are off.

#### 4.4.2.2 Trip 1

a. Turn R75 CCW slowly until the Trip 1 LED on the front panel lights up.

 <p>University of Massachusetts UMASS Lowell Research Reactor</p>	<p><b>GEN2 NMP-1000 LINEAR POWER CHANNEL INSTALLATION PLAN</b></p>	<p>Revision: 0 Date Issued: _____ Page 7 of 9</p>
---	--	---

#### 4.4.2.3 Trip 2

- a. Set the current source for an output of 1.2mA.
- b. Turn R61 CCW slowly until the Trip 2 LED on the front panel lights up.

#### 4.4.2.4 High Voltage

- a. Turn R47 CW slowly until the High Voltage LED on the front panel lights up at slightly below the setpoint of

650 V.

#### 4.4.2.5 Restore System, Normal Operation

- a. Adjust R4 on the Motherboard until the Main Menu displays HV:  $800 \pm 12$  Vdc
- b. Set the current source for an output of 1.0mA.
- c. Select the Trip Reset button on the GAIN MENU Display.
- d. Observe that all front panel trip indicator LEDs are off.

ISOLATION AMPLIFIER – CALIBRATION AND FUNCTIONAL CHECK

Use the following graphics to locate calibration components.

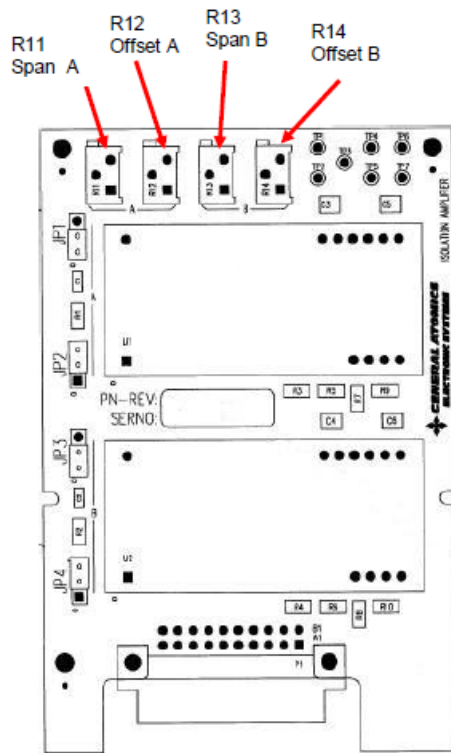

Figure 4-4 – Isolation Amplifier Board Layout

There are 2 isolation amplifier outputs, A and B, that indicate the percent power value. They can be jumper configured to either 4-20mA or 0-10V. This calibration section is written for the 4-20 mA output. If 0-10 Vdc is desired, change the switch setting and convert the mA values to Vdc.

#### Analog Outputs Jumper Settings

Output		4-20mA	0-10V
A	JP1	1-2	2-3
	JP2	2-3	1-2
B	JP3	1-2	2-3
	JP4	2-3	1-2

#### 4.5.2.1 Setup

- a. Verify that the jumpers are set for the 4-20 mA configuration on the Isolation Amplifier board per Table 4-3.

#### 4.5.2.2 Analog Output A

- a. Set the current source for an output of zero current.

 <p>University of Massachusetts UMASS Lowell Research Reactor</p>	<b>GEN2 NMP-1000 LINEAR POWER CHANNEL INSTALLATION PLAN</b>	Revision: 0 Date Issued: _____ Page 9 of 9
---	---	--

- b. Set the DMM to measure mA and connect it to Pins 22 (+) and 23 (-) of J5 (DB-37 Connector) on the rear of the NMP-1000.
- c. On the front panel screen select Gain and E-3.
- d. Adjust R12 on the Isolation Amplifier board until the DMM reads  $4.0 \pm 0.2$  mA.
- e. Set the current source for an output of 1.2 mA.
- f. Adjust R11 on the Isolation Amplifier board until the DMM reads  $20.0 \pm 0.2$  mA.

#### 4.5.2.3 Analog Output B

- a. Connect the DMM set to measure mA to Pins 24 (+) and 25 (-) of J5 (DB-37 Connector) on the rear of the NMP-1000.
- b. Set the current source for an output of zero current.
- c. Adjust R14 on the Isolation Amplifier board until the DMM reads  $4.0 \pm 0.2$  mA.
- d. Set the current source for an output of 1.2 mA.
- e. Adjust R13 on the Isolation Amplifier board until the DMM reads  $20.0 \pm 0.2$  mA.

#### WATCH DOG TIMER

- a) Select trip reset on the front panel screen.
- b) Verify trips 1-3 LEDs on the front panel are illuminated
- c) On Digital interface board select dip switch 4 to OFF position. Verify the heartbeat has stopped pulsing on the NLW.
- a) Verify the test fixture's Trips1-3 LED's are illuminated.
- b) On Digital interface board reset dip switch 4 to ON position and cycle power on the NLW. Verify heartbeat is pulsing.

#### 1. Installation

Prior to installing verify the following internal wires are disconnected

- a. Remote Display (J-8, DB-9) to Digital Interface Board.
- b. Ethernet to Digital Interface Board.

End of Plan



 <p>University of Massachusetts Lowell <b>UMASS</b> Research Reactor</p>	<p><u>Linear Power Channel Check and Calibration</u></p> <p>Control Doc. No. CP-2-04</p>	<p>Procedure No.: CP-2 Revision: 4 Date Issued: DRAFT Page 1 of 17</p>
--	--	--

APPROVED:

APPROVED:

PURPOSE:

Technical Specification 4.2.3 requires annual calibration for the reactor power-level measuring channels. The purpose of this procedure is to provide instructions on how to consistently calibrate the NMP-1000 processing modules. Each NMP-1000 module houses components of its respective safety-significant multi-range linear channel and defense-in-depth scram logic channel. This procedure provides the steps to check the proper channel function and to determine if calibration adjustments are required. This procedure also provides the necessary steps for making calibration adjustments.

Operators performing this procedure, will check calibration of the NMP-1000, to ensure linearity of each range of the multi-range linear current monitoring modules. The trip set points for the scram logic channel are also checked and verified to the appropriate set points on the trip relay board housed inside the module. Following the check, the processing module is returned to the control system and functionally tested to ensure proper connections have been made. Modules (Pico 1 & Pico 2) are interchangeable, but should be kept in the same positions to ensure continuity of operations.

SCOPE:

This procedure applies to the NMP-1000 linear power measuring channels.

RESPONSIBILITIES:

A licensed Senior Reactor Operator (SRO) shall perform or supervise the performance of Section 1 (Checks) of this procedure. The SRO performing this procedure, will check calibration of the NMP-1000, to ensure linearity of each range of the multi-range linear current monitoring modules. The trip set points for the scram logic channel are also checked and verified to the appropriate set points on the trip relay board housed inside the module. Following the check, the processing module is returned to the control system and functionally tested to ensure proper connections have been made. Modules (Pico 1 & Pico 2) are interchangeable, but should be kept in the same positions to ensure continuity of operations.

Should the Channel Check reveal any discrepancies, the Operator performing the Channel Check shall refer notify the CRO or RS. It shall then be the responsibility of the CRO or RS to perform the Calibration elements of this procedure. The Chief Reactor Operator or Reactor Supervisor shall perform or supervise Sections 2, 3, 4, or 5 (Calibrations).

ASSOCIATED MATERIAL:

Keithley Model 220 Current Source

Digital Multi-meter (DMM)

Calibration Forms: RF-CP2-CH1A, RF-CP2-CH2A, RF-CP2-CH1B, RF-CP2-CH2B

Ultra Low Noise Rockbestos BNC cable, 4 FT length

DB9 Forced – Natural Convection Cable/Switch

Circuit Extension Card

REFERENCE DOCUMENTS:

Technical Specifications, paragraph 4.2.3

RF-CP2 Linear Power Channel Calibration (attached)

Keithley Model 220 operation and maintenance manual

NMP-1000 Gen 2 operation and maintenance manual

PROCEDURE:

**1 NMP-1000 OPERATIONAL CHECK (RF-CP2-CHxA):**

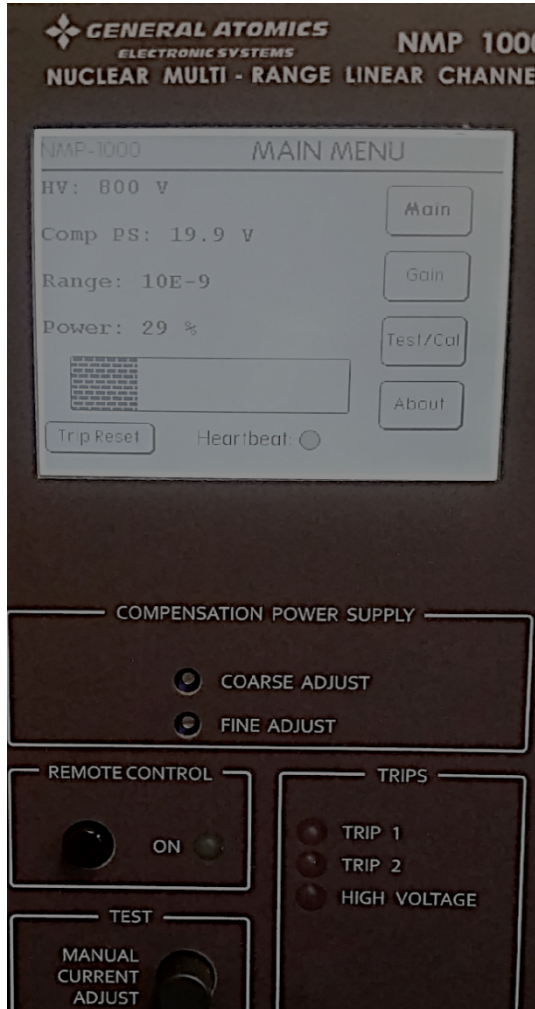

Figure 1. NMP-1000 Gen. 2

**CAUTION:** High voltage (1kV) at J2 and within the NMP-1000 chassis present a shock hazard.

1.1 Pre-check Conditions

1.1.1 Remove power to the NMP-1000 by placing the power switch S/F1 to the OFF position.

1.1.2 Disconnect ALL coaxial cables (SIGNAL, HV, and COMP) from the unit.

1.1.3 Connect the Keithley Model 220 to the SIGNAL INPUT jack J1 on the rear control panel of the NMP-1000 (access the jack through the rear console hatch).

1.1.4 Apply power to the NMP-1000 by placing the power switch S/F1 to the ON position.

1.1.5 Verify the following Pre-Check Condition on the NMP1000:

REMOTE CONTROL OFF  
(LED not illuminated)

MANUAL CURRENT ADJUST  
knob turned full counterclockwise

GAIN (MENU)  
RANGE SET TO "AUTO"

TEST/CAL (MENU)  
SET TO "OPERATE"

1.2 Linear Power Response Check

NOTE: To set the current output on the Keithley model 220, type in the ampere value in scientific notation, press enter, and then press operate.

1.2.1 Apply the 50% linear power test current specified on the calibration form to J1.

1.2.2 Record the NMP front panel meter, computer display, and chart recorder (channel 1 only) power indications. If any of the power indication values are not 50% (500kW) within a tolerance  $\pm 2\%$  (10kW), circle this value in red ink.

1.2.3 Apply the 100% linear power test current specified on the calibration form to J1.

- 1.2.4 Record the NMP front panel meter, computer display, and chart recorder (channel 1 only) power indications. If any of the power indication values are not 100% (1,000kW) within a tolerance  $\pm 2\%$  (20kW), circle this value in red ink.
- 1.2.5 Apply the 120% linear power test current specified on the calibration form to J1.
- 1.2.6 Record the NMP front panel meter, computer display, and chart recorder (channel 1 only) power indications. If any of the power indication values are not 120% (1,200 kW) within a tolerance  $\pm 2\%$  (20 kW), circle this value in red ink.
- 1.2.7 If no power indication values are circled in red proceed to Step 1.3.
- 1.2.8 If during either steps 1.2.2 or 1.2.4 **both** the NMP meter indication **and** the computer display indication is circled in red perform Step 2.0 *Electrometer Calibration*.
- 1.2.9 If during either steps the NMP meter indication **only** is circled in red perform Step 3.0 *Front Panel Meter Adjustment*.
- 1.2.10 If during either steps 1.2.2 or 1.2.4 the computer display or recorder power indication value is circled in red perform Step 4.0 *Isolated Output Adjust*.

### 1.3 Autorange Switch Point Checks

- 1.3.1 Select GAIN on the Display, select Auto, then select Main.
- 1.3.2 Set the current on the current source to 0.1 $\mu$ A. Using steps of 0.1  $\mu$ A, increase current to 0.9  $\mu$ A (0.91  $\mu$ A typical).. Observe that the range is switched to the next higher range at  $\sim 90\%$  Power.
- 1.3.3 Using steps of 0.1 $\mu$ A, decrease the current of 0.9  $\mu$ A to 0.1  $\mu$ A. Observe that the range is switched to the next lower range at  $\sim 8\%$  Power (0.75  $\mu$ A typical).

**NOTE:** The auto-range set points are encoded in the NMP firmware and not user adjustable. The above steps merely replicate the factory acceptance.

### 1.4 Forced Convection High Neutron Flux Alarm / SCRAM Trip

- 1.4.1 Set the current source as specified on the calibration form to J1 ( $\sim 100\%$  of 1 MW, typically 1.0E-4 A).
- 1.4.2 Step up the current source in small intervals ( $\sim 0.05\text{E-}4$  A) until “trip 1” LED illuminates.
- 1.4.3 Check form (SAT/UNSAT) If the “trip 1” value is not 105%  $\pm 2\%$ , then perform Step 3.0 Trip Set Point Adjust.

- 1.4.4 Set the current source as specified on the calibration form to J1 (~110% of 1 MW typically  $1.1E-4$  A).
- 1.4.5 Step up the current source in small intervals ( $\sim 0.05 \times 10^{-4}$  A) until “trip 2” LED illuminates. Record the trip 2 current value and reading.
- 1.4.6 If the “trip 2” value is not  $110\% \pm 2\%$ , then perform Step 3.0 Trip Set Point Adjust.

#### 1.5 Natural Convection Neutron Flux Alarm / SCRAM Trip Check

- 1.5.1 Set the current source as specified on the calibration form to J1 (~80% of 0.1 MW, typically  $1.0E-5$  A).
- 1.5.2 Step up the current source in small intervals ( $\sim 0.05E-4$  A) until “trip 1” LED illuminates. In order for the trips to occur, the unit must autorange into the  $1.0E-4$  range, it is necessary that the small incremental changes in current from the current source be slowly increased to determine the appropriate trip setpoint. Record the trip 1 and 2 current values and readings.
- 1.5.3 If the “trip 1” value is not  $105\% \pm 2\%$ , then perform Step 3.0 Trip Set Point Adjust.
- 1.5.4 If the “trip 2” value is not  $110\% \pm 2\%$ , then perform Step 3.0 Trip Set Point Adjust.

#### 1.6 High-Voltage Failure Alarm and SCRAM Trip

- 1.6.1 Carefully remove the NMP-1000 from the control console and then remove the chassis cover.
- 1.6.2 While observing the front panel high-voltage reading, turn R4 (HV Trip) CCW until the HV trip occurs.



*Figure 2. High Voltage Adjust on NMP MotherBoard*

- 1.6.3 Record the HV trip voltage value.

- 1.6.4 If the HV trip voltage value is not  $>0.7$  kV, then perform Step 7.0 High Voltage Trip Adjustment.
- 1.6.5 Turn R4(HV ADJ) CCW until a 0.80 kV indication appears on the front panel high-voltage meter. Record the high voltage value. DO NOT EXCEED 1.0 kV.
- 1.6.6 If no further adjustments are necessary, proceed to Step 8 *Return to Service*

**NOTE:** The Chief Reactor Operator or Reactor Supervisor shall perform or supervise the steps in Sections 2, 3, 4, or 5.

## 2 ELECTROMETER CALIBRATION (RF-CP2-CHxB):

**DANGER:** High voltages at J2 and within the NMP-1000 chassis present a shock hazard.

### 2.1 Utility Power Supply and Voltage Regulation Checks

2.1.1 Using an oscilloscope, measure output voltage and ripple of the following power supplies, and record results on FORM:

- Motherboard (Use Motherboard TP9 as Ground reference):
  - 24 Vdc Switching Power Supply (TP10)
  - +15 Vdc Voltage Regulator for Analog Board (TP6)
  - -15 Vdc Voltage Regulator for Analog Board (TP8).
- Digital Board:
  - +5 Vdc Voltage Regulator for module Amulet and GPIO (TP22) (Use Digital Board TP9 as Ground reference)
  - +3.3 Vdc Voltage Regulator for Netburner/Watchdog (TP23) (Use Digital Board TP9 as Ground reference)
  - +5V\_ISO Isolated Voltage Regulator for Remote Amulet RS232 (TP24) (Use Digital Board ISO Ground TP25 as Ground reference).

2.1.2 If any power supply or voltage regulator checks are found to be out of tolerance, then contact the Reactor Supervisor or Reactor Engineer to evaluate if components need replacement.

## 2.2 Electrometer Calibration

**NOTE 1:** Refer to the following graphic to locate calibration components for the analog amplifier.

**NOTE 2:** In general, the NMP-1000 and detector should be setup such that  $100\mu A$  equals 100% reactor power. This is accomplished by first performing the bench calibration described below, then reinstalling the instrument and operating the reactor to determine actual power levels (via other instrumentation), and physically repositioning the compensated ion detector so the NMP indicated power equals actual power.

**NOTE 3:** When adjusting the gain and offset of the lowest ranges in the following steps, it may be necessary to wait several minutes for the electrometer circuits to respond and stabilize.

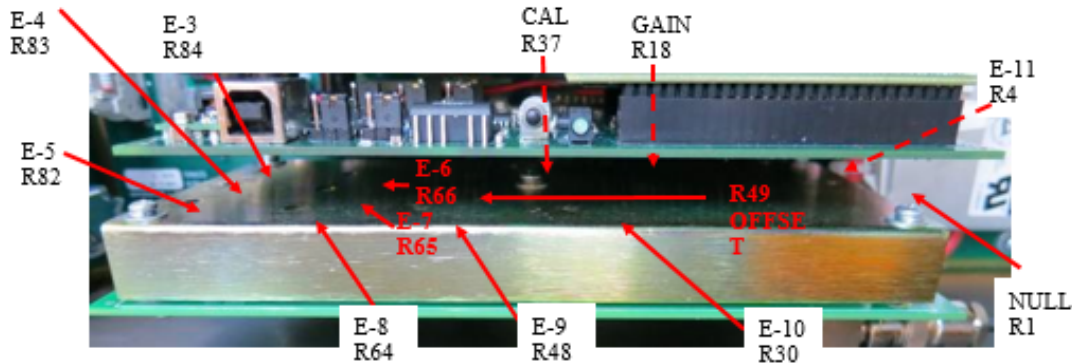

Figure 3. Analog Amplifier

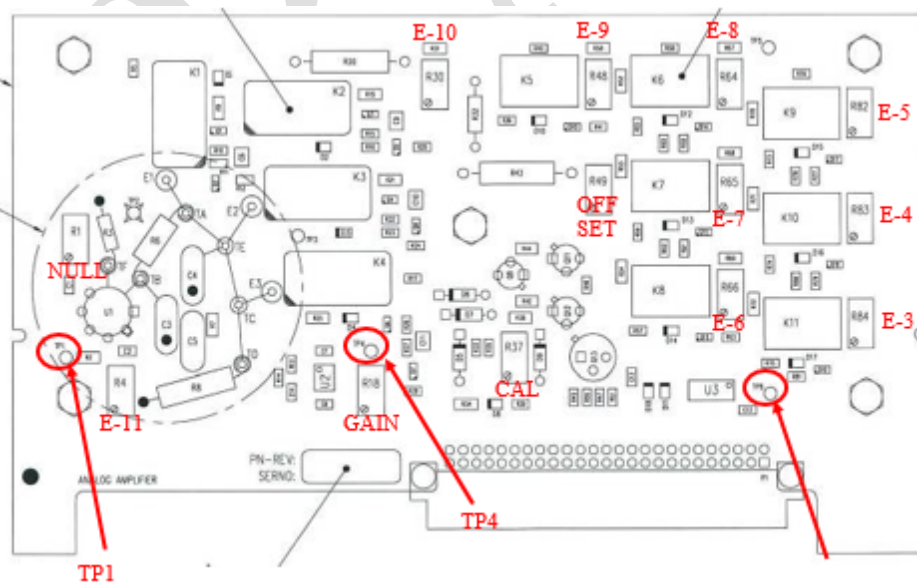

Figure 4. Analog Amplifier Board Layout

### CAUTION

**Anytime any circuit boards are removed or installed, instrument power must be turned OFF to prevent damage to the circuits. Discharge static electricity to the extent practicable before handling or working with circuits.**

## 2.3 Power/Current Calibration

### 2.3.1 Setup / Null

- 2.3.1.1 Unplug BNC Connector from amplifier board, install the extender card for the analog amplifier, and confirm the EMI shield is installed.
- 2.3.1.2 Connect current source to J1 on amplifier board.
- 2.3.1.3 Connect a DMM to TP1 (+) on the Analog Amplifier card and TP6 (AGND) on extender card (located on the lower right side of the amplifier card – also note the entire EMI shield is tied to ground if TP6 is not reachable).
- 2.3.1.4 Set the current source for an output of zero current (0.000nA, for example) and wait at least 5 minutes. If this is not possible, the null can be set as high as 30% of the 1.0E-11 scale using the Keithley current source.
- 2.3.1.5 Record the As-found voltage on the associated FORM.
- 2.3.1.6 Adjust potentiometer R1 until the DMM reads 0.00 ±0.25 Vdc on TP1, after every adjustment wait at least 5 minutes for the voltage to settle.
- 2.3.1.7 Record the after calibration voltage on the associated form.
- 2.3.1.8 On the MAIN MENU Display, select the Gain button.

### 2.3.2 E-11 Scale

- 2.3.2.1 Select the E-11 button on the GAIN MENU Display.
- 2.3.2.2 Set the current source for an output of 10pA.
- 2.3.2.3 Record the As-found voltage on the associated form.

**NOTE:** It may take several minutes for the reading to stabilize in the lowest ranges. Wait for the reading to stabilize before making final adjustments.

- 2.3.2.4 Adjust potentiometer R4 until the DMM reads -10.00 ±0.05 Vdc.
- 2.3.2.5 Record the after calibration voltage on the associated form.
- 2.3.2.6 Set the current source for an output of 5pA.



2.3.2.7 Verify that the DMM reads  $-5.00 \pm 0.50$  Vdc after the reading has stabilized.

2.3.2.8 Record the As-found voltage on the associated form.

### 2.3.3 E-10 Scale

2.3.3.1 Select the E-10 button on the GAIN MENU Display.

2.3.3.2 Set the current source for an output of 100pA.

2.3.3.3 Record the As-found voltage on the associated FORM.

2.3.3.4 Adjust potentiometer R30 until the DMM reads  $-10.00 \pm 0.05$  Vdc.

2.3.3.5 Record the after calibration voltage on the associated FORM.

### 2.3.4 E-9 Scale

2.3.4.1 Select the E-9 button on the GAIN MENU Display.

2.3.4.2 Set the current source for an output of zero current.

2.3.4.3 Record the As-found voltage on the associated FORM.

2.3.4.4 Adjust potentiometer R49 until the DMM reads  $0.00 \pm 0.1$  Vdc or until R49 is adjusted fully CCW.

2.3.4.5 Record the after calibration voltage on the associated FORM.

2.3.4.6 Set the current source for an output of 1nA.

2.3.4.7 Record the As-found voltage on the associated FORM.

2.3.4.8 Adjust potentiometer R48 until the DMM reads  $-10.00 \pm 0.05$  Vdc.

2.3.4.9 Record the after calibration voltage on the associated FORM.

### 2.3.5 E-8 Scale

2.3.5.1 Select the E-8 button on the GAIN MENU Display.

2.3.5.2 Set the current source for an output of 10nA.

2.3.5.3 Record the As-found voltage on the associated FORM.

2.3.5.4 Adjust potentiometer R66 until the DMM reads  $-10.00 \pm 0.05$  Vdc.

2.3.5.5 Record the after calibration voltage on the associated FORM.

### 2.3.6 E-7 Scale

2.3.6.1 Select the E-7 button on the GAIN MENU Display.

2.3.6.2 Set the current source for an output of 100nA.

2.3.6.3 Record the As-found voltage on the associated FORM.

2.3.6.4 Adjust potentiometer R65 until the DMM reads  $-10.00 \pm 0.05$  Vdc.

2.3.6.5 Record the after calibration voltage on the associated FORM.

## E-6 Scale

- 2.3.7.1 Select the E-6 button on the GAIN MENU Display.
- 2.3.7.2 Set the current source for an output of  $1\mu\text{A}$ .
- 2.3.7.3 Record the As-found voltage on the associated FORM.
- 2.3.7.4 Adjust potentiometer R64 until the DMM reads  $-10.00 \pm 0.05$  Vdc.
- 2.3.7.5 Record the after calibration voltage on the associated FORM.

## 2.3.8 E-5 Scale

- 2.3.8.1 Select the E-5 button on the GAIN MENU Display.
- 2.3.8.2 Set the current source for an output of  $10\mu\text{A}$ .
- 2.3.8.3 Record the As-found voltage on the associated FORM.
- 2.3.8.4 Adjust potentiometer R82 until the DMM reads  $-10.00 \pm 0.05$  Vdc.
- 2.3.8.5 Record the after calibration voltage on the associated FORM.

## 2.3.9 E-4 Scale

- 2.3.9.1 Select the E-5 button on the GAIN MENU Display.
- 2.3.9.2 Set the current source for an output of  $100\mu\text{A}$ .
- 2.3.9.3 Record the As-found voltage on the associated FORM.
- 2.3.9.4 Adjust potentiometer R83 until the DMM reads  $-10.00 \pm 0.05$  Vdc.
- 2.3.9.5 Record the after calibration voltage on the associated FORM.

## 2.3.10 Gain

- 2.3.10.1 Connect a DMM to TP17 (+) and TP19 (-) on the extender card connected to the analog amplifier, and set it to measure Vdc.
- 2.3.10.2 Set the current source for an output of  $100\mu\text{A}$  (100% Indicating Power).
- 2.3.10.3 Record the As-found voltage on the associated FORM.
- 2.3.10.4 Adjust potentiometer R18 until the DMM reads  $8.33 \pm 0.05$  Vdc on TP17.
- 2.3.10.5 Record the after calibration voltage on the associated FORM.
- 2.3.10.6 Set the current source for an output of  $12.0\mu\text{A}$  (120% Indicating Power).
- 2.3.10.7 Verify the DMM reads  $10.00 \pm 0.05$  Vdc.
- 2.3.10.8 Record the As-found voltage on the associated FORM.

**NOTE:** Tests time out and the NMP returns to normal operation after 50 seconds. Re-enable the test mode if the adjustment is not completed within that time.

### 2.3.11 Calibrate High and Low Test Current

- 2.3.11.1 Select the AUTO button on the GAIN MENU Display.
- 2.3.11.2 Select the Test/Cal button on the GAIN MENU Display.
- 2.3.11.3 Select the Calibrate High button on the TEST/CAL MENU Display.
- 2.3.11.4 Record the as found voltage on the associated FORM.
- 2.3.11.5 Adjust potentiometer R37 until the DMM reads  $9.3 \pm 0.1$  Vdc on TP17, this should correlate to 120% power of the 1E-4 range.
- 2.3.11.6 Record the after calibration voltage on the associated FORM.
- 2.3.11.7 Select the Calibrate Low button on the TEST/CAL MENU Display.
- 2.3.11.8 Verify the voltage on TP17 is  $1.40 \pm 0.1$  VDC, this should correlate to 19% power of the 1E-4 range.
- 2.3.11.9 Record the voltage on the associated FORM.

### 2.3.12 Test (Man) Current

- 2.3.12.1 Turn the MANUAL CURRENT ADJUST potentiometer on the front panel fully counter clockwise (CCW).
- 2.3.12.2 Select the MAN Current button on the TEST/CAL MENU Display.

**NOTE:** Due to the nature of the manual test circuit, it may not be possible to cover the lowest ranges with the potentiometer.

- 2.3.12.3 While observing the Gain Range on the TEST/CAL Menu Display, slowly start turning the MANUAL CURRENT ADJUST potentiometer on the front panel clockwise (CW).
- 2.3.12.4 As the potentiometer is turned CW, observe the Gain Ranges change. Record the observed ranges on the applicable FORM.
- 2.3.12.5 Turn the Manual Current Adjust potentiometer CCW to display 112% power in the E-4 range on the front panel display.
- 2.3.12.6 Measure between TP17 (+) and TP19 (-) and insure voltage reads  $9.3 \pm 0.1$  Vdc. Record as-found data in the FORM.
- 2.3.12.7 Turn Manual Current Adjust potentiometer CCW to display 17% power in the E-4 range on the front panel display.
- 2.3.12.8 Measure between TP17 (+) and TP19 (-) and insure the voltage reads  $1.4 \pm 0.1$  Vdc. Record as-found data in the FORM.
- 2.3.12.9 Turn the MANUAL CURRENT ADJUST potentiometer on the front panel fully counter clockwise (CCW).

2.3.12.10 Remove extender card and reconnect cables to J1 (internal coax) and J1 on rear panel (current source).

### 3 TRIP/ALARM CALIBRATION AND FUNCTIONAL CHECK

**NOTE:** Refer to the following graphic to locate calibration components for the trip/alarm circuit.

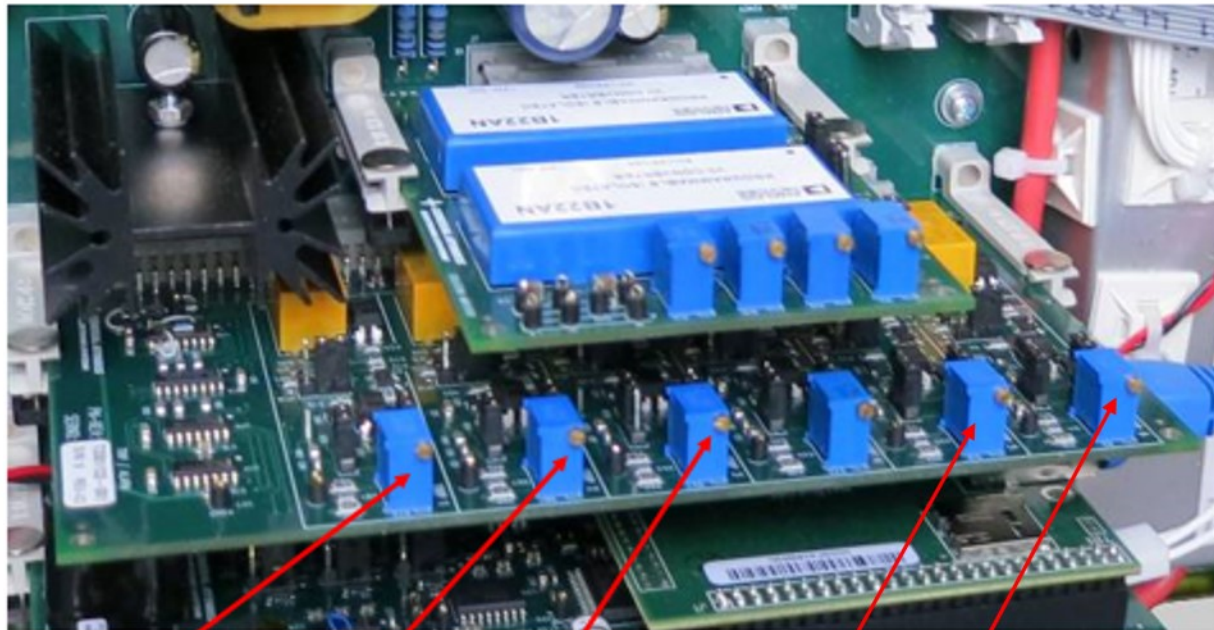

R75  
TRIP 1

R61  
TRIP 2

R47  
HV TRIP

R19 NC  
TRIP 1

R5 NC  
TRIP 2

**NOTE:** The HV Trip must be set above 300 VDC to protect the HV power supply performance, and must be at or above 750 VDC for optimal performance of the detector.

#### 3.1 Trip Setup

- 3.1.1 Adjust R4 on the Motherboard until the MAIN MENU displays a HV of 800 VDC.
- 3.1.2 Turn R75 on the Trip/Alarm board fully CW.
- 3.1.3 Turn R61 on the Trip/Alarm board fully CW.
- 3.1.4 Turn R47 on the Trip/Alarm board fully CCW.

**NOTE 1:** Power Trip 1 is set at 105% reactor power and is the reactor power high alarm. Power Trip 2 is set at 110% reactor power and is the reactor power high scram. 105  $\mu$ A is the current level expected for a high power alarm and corresponds to 105% reactor power.

- 3.1.5 Set the current source for an output of 105 $\mu$ A.
- 3.1.6 Confirm the front panel display reads 105% power  $\pm$ 2%
- 3.1.7 Select the Trip Reset button on the MAIN MENU Display.
- 3.1.8 Observe that all front panel trip indicator LEDs are off.

**NOTE 2:** While adjusting trip set points it may be necessary to reset trips and adjust the potentiometers several times to set the trips for optimal settings.

### 3.2 Trip 1 Forced Convection High Power Alarm

- 3.2.1 Turn R75 CCW slowly until the Trip 1 LED on the front panel lights up.
- 3.2.2 Record as left conditions (satisfactory/unsatisfactory) on the applicable FORM.

### 3.3 Trip 2 Forced Convection High Power Trip

- 3.3.1 Set the current source for an output of 110 $\mu$ A.
- 3.3.2 Confirm the front panel display reads 110% power  $\pm$ 1%.
- 3.3.3 Turn R61 CCW slowly until the Trip 2 LED on the front panel lights up.
- 3.3.4 Lower the current source value below the alarm trip level and then slowly increase the current source value until TRIP 2 is received.
- 3.3.5 Record the after calibration High Power Trip current value on the applicable FORM.

**NOTE 3:** This is the current level expected for a high power scram and corresponds to 110% reactor power. If a different value is desired, adjust the current accordingly.

### 3.4 High Voltage Trip

- 3.4.1 Turn R47 CW slowly until the High Voltage LED on the front panel lights up.
- 3.4.2 Record as left conditions (satisfactory/unsatisfactory) on the applicable FORM.

### 3.5 Natural Convection High Power Alarm & TRIP

**NOTE 4:** NC Power Trip 1 is set at 10.5% reactor power and is the reactor power high alarm. NC Power Trip 2 is set at 11.0% reactor power and is the reactor power high scram. 10.5  $\mu$ A is the current level expected for a high power alarm and corresponds to 10.5% reactor power. The Alarm and SCRAM for this range occur in the 1E-4 range. Due to this operations in natural convection are limited to 80kW (80% of the 1E-5 range).

- 3.5.1 Set the current source for an output of approximately 9.1  $\mu$ A. Unit should autorange (10E-4 range) and both trips may activate. If trips activate step current down by 0.1  $\mu$ A increments until trips can both be reset. Do not drop below 8.0  $\mu$ A, in order to keep unit in the 10E-4 range.
- 3.5.2 After resetting both TRIP 1 and TRIP 2, set current to 10.0  $\mu$ A, then increase current by 0.1  $\mu$ A until TRIP 1 is activated.
- 3.5.3 Confirm the front panel display reads 10% power  $\pm$ 2% when TRIP 1 activates. TRIP 1 should activate at a current of 10.5  $\mu$ A  $\pm$ 2% .
- 3.5.4 To adjust NC TRIP 1 turn R19 CCW slowly until the Trip 1 LED on the front panel lights up
- 3.5.5 Record as left conditions (satisfactory/unsatisfactory) on the applicable FORM.

### 3.6 Trip 2 Natural Convection High Power Trip

- 3.6.1 Continue using the current source for an output of 10.5  $\mu$ A, increase current by 0.1  $\mu$ A until TRIP 2 is activated. TRIP 2 should activate when current is 11.0  $\mu$ A  $\pm$ 1%.
- 3.6.2 Confirm the front panel display reads 11% power  $\pm$ 1%.
- 3.6.3 To adjust NC TRIP 2 turn R5 CCW slowly until the Trip 2 LED on the front panel lights up.
- 3.6.4 Record the after calibration High Power Trip current value on the applicable FORM.

**NOTE:** This is the current level expected for a high power scram and corresponds to 110% reactor power. If a different value is desired, adjust the current accordingly.

## 4 **Restore System to Normal Operations**

- 4.1.1 Adjust R4 on the Motherboard until the Main Menu displays 800  $\pm$ 10 Vdc.
- 4.1.2 Set the current source for an output of 100  $\mu$ A.
- 4.1.3 Select the Trip Reset button on the MAIN MENU Display.
- 4.1.4 Observe that all front panel trip indicator LEDs are off.

## 5 Isolation Amplifier Calibration and Functional Check

**NOTE:** Refer to the following graphic to locate calibration components for the isolation amp circuit.

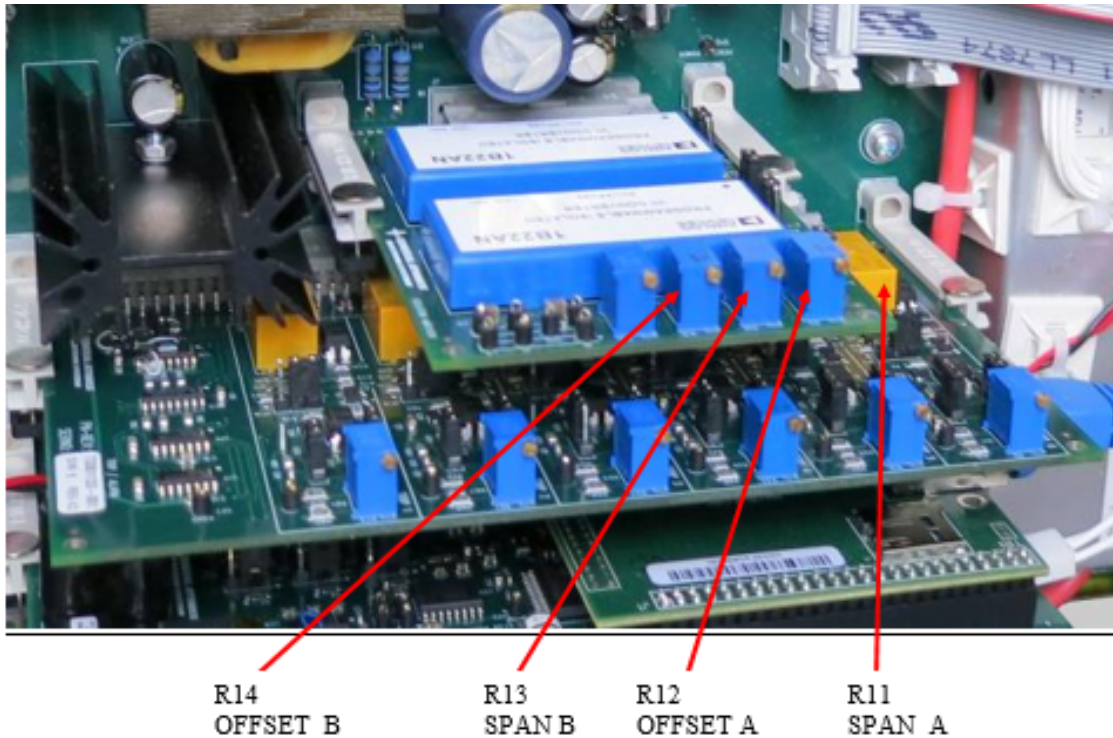

*Figure 5. Isolated Outputs*

### 5.1 Analog Output A

- 5.1.1 Set the current source for an output of zero current.
- 5.1.2 Set the DMM to measure mA and connect it to Pins 22 (+) and 23 (-) of J5 (DB-37 Connector) on the rear of the NMP-1000.
- 5.1.3 On the front panel screen, select Gain and E-4.
- 5.1.4 Record the As-found current on the associated FORM.
- 5.1.5 Adjust R12 on the Isolation Amplifier board until the DMM reads  $4.0 \pm 0.2$  mA.
- 5.1.6 Record the after calibration current on the associated FORM.
- 5.1.7 Set the current source for an output of  $120\mu\text{A}$ .
- 5.1.8 Record the As-found current on the associated FORM.

5.1.9 Adjust R11 on the Isolation Amplifier board until the DMM reads  $20.0 \pm 0.2$  mA.

5.1.10 Record the after calibration current on the associated FORM.

## 5.2 Analog Output B

5.2.1 Connect the DMM set to measure VDC to Pins 24 (+) and 25 (-) of J5 (DB-37 Connector) on the rear of the NMP-1000.

5.2.2 Set the current source for an output of zero current.

5.2.3 Record the As-found voltage on the associated FORM.

5.2.4 Adjust R14 on the Isolation Amplifier board until the DMM reads  $0.0 \pm 0.2$  VDC.

5.2.5 Record the after calibration current on the associated FORM.

5.2.6 Set the current source for an output of  $120\mu\text{A}$ .

5.2.7 Record the As-found current on the associated FORM.

5.2.8 Adjust R13 on the Isolation Amplifier board until the DMM reads  $10.0 \pm 0.2$  VDC.

5.2.9 Record the after calibration current on the associated FORM.

## 6 **Compensation Power Supply**

### 6.1 Minimum Value Full CCW

6.1.1 Record the as-found compensation power supply voltage on the FORM, as displayed on the MAIN MENU.

6.1.2 Turn both the Coarse Adjust and Fine Adjust potentiometers on the front panel fully CCW.

6.1.3 On the MAIN MENU Display, verify COMP PS: VALUE is less than 5 Vdc.

6.1.4 Record the As-found voltage on the associated FORM.

### 6.2 Maximum Value Full CW

6.2.1 Turn both the Coarse Adjust and Fine Adjust potentiometers on the front panel fully CW.

6.2.2 On the MAIN MENU Display, verify COMP PS: VALUE is larger than 45 Vdc.

6.2.3 Record the As-found voltage on the associated FORM.



 <p>University of Massachusetts Lowell <b>UMASS</b> Research Reactor</p>	<p><u>Linear Power Channel Check and Calibration</u></p> <p>Control Doc. No. CP-2-04</p>	<p>Procedure No.: CP-2 Revision: 4 Date Issued: DRAFT Page 17 of 17</p>
--	--	---

### 6.3 Restore to Normal Operations

- 6.3.1 Adjust the Coarse Adjust and Fine Adjust potentiometers for a COMP PS value of the initial value recorded in Step 6.1.1 or no more than 60 Vdc. Record as-left voltage on the FORM.

## 7 **PERFORMING REPAIRS TO NMP-1000 Module**

**NOTE:** Contact the manufacturer if replacement parts are required to be ordered.

- 7.1.1 IF hardware malfunctions were NOT found during the calibration OR parts replacement was NOT directed, THEN skip Steps 7.1.2 through 7.1.7 AND GO TO Subsection 8.
- 7.1.2 Troubleshoot the defective NMP-1000 using the manufacturer's manual (T3401000-1UM), or consultation with the manufacturer as necessary.
- 7.1.3 Perform the following bulleted items as needed:
- Clean, tighten, and re-terminate/solder electrical connections
  - Repair structural mounting hardware.
- 7.1.4 IF a component is found defective or is being replaced, and is listed in Appendix A, THEN replace the component with the correct part number as listed in Appendix A.
- 7.1.5 Document any hardware that was used for repair on the supplemental material list attached to this work order.
- 7.1.6 Document the troubleshooting findings and actions taken to repair the NMP-1000 module.
- 7.1.7 Once repairs are complete, restart the calibration by restarting at Section 1.

## 8 **Restore to Normal Operation**

- 8.1.1 Before closing the chassis verify the wiring to both the J8 and J9 connections within the instrument chassis have been disconnected.
- 8.1.2 Disconnect the current source and return NMP-1000 to appropriate console position.
- 8.1.3 Reconnect the HV, Sig and Comp detector lines to the appropriate NMP-1000 module connectors.
- 8.1.4 Power NMP-1000 unit and set the NMP-1000 to local control with the front-panel push button switch.
- 8.1.5 Note any changes or issues with unit in Logbook.