

CHAPTER 6.0 - ENGINEERED SAFETY FEATURESTABLE OF CONTENTS

	<u>PAGE</u>
6.0 <u>ENGINEERED SAFETY FEATURES</u>	6.1-1
6.1 <u>ENGINEERED SAFETY FEATURES MATERIALS</u>	6.1-1
6.1.1 Metallic Materials	6.1-1
6.1.1.1 Materials Selection and Fabrication	6.1-1
6.1.1.2 Composition, Compatibility, and Stability of Containment and Core Spray Coolants	6.1-3
6.1.2 Organic Materials	6.1-4
6.1.2.1 Formation of Combustible Gas Mixtures from Organic Materials and Protective Coating	6.1-8
6.1.3 Postaccident Chemistry	6.1-9
6.1.3.1 Steamline Break Inside Containment	6.1-9
6.1.3.2 Main Feedwater Line Break Inside Containment	6.1-10
6.1.3.3 Loss-of-Coolant Accident	6.1-11
6.1.4 References	6.1-11
6.2 <u>CONTAINMENT SYSTEMS</u>	6.2-1
6.2.1 Containment Functional Design	6.2-1
6.2.1.1 Containment Structure	6.2-1
6.2.1.1.1 Design Bases	6.2-1
6.2.1.1.2 Design Features	6.2-2
6.2.1.1.3 Design Evaluation	6.2-3
6.2.1.2 Containment Subcompartments	6.2-14
6.2.1.2.1 Design Basis	6.2-14
6.2.1.2.2 Deleted	6.2-15
6.2.1.2.3 Design Evaluation	6.2-15
6.2.1.2.3.1 Analytical Models	6.2-15
6.2.1.2.3.2 Break Type and Size	6.2-16
6.2.1.2.3.3 Model Description	6.2-17
6.2.1.2.3.4 Pressure Responses	6.2-19
6.2.1.3 Mass and Energy Release Analyses For Postulated Loss-of-Coolant Accidents	6.2-22
6.2.1.3.1 Long Term LOCA Mass and Energy Releases	6.2-22
6.2.1.3.2 LOCA M&E Release Phases	6.2-25
6.2.1.3.3 Computer Codes	6.2-26
6.2.1.3.4 Break Size and Location	6.2-26
6.2.1.3.5 Application of Single-Failure Criterion	6.2-27a
6.2.1.3.6 Acceptance Criteria for Analyses	6.2-27a
6.2.1.3.7 Mass and Energy Release Data	6.2-27a
6.2.1.3.7.1 Blowdown Mass and Energy Release Data	6.2-27a
6.2.1.3.7.2 Reflood Mass and Energy Data	6.2-27b
6.2.1.3.7.3 Post-Reflood Mass and Energy Release Data	6.2-27d
6.2.1.3.7.4 Decay Heat Model	6.2-27e
6.2.1.3.7.5 Steam Generator Equilibration and Depressurization	6.2-27e
6.2.1.3.7.6 Sources of Mass and Energy	6.2-27f
6.2.1.3.8 Conclusions	6.2-27h

TABLE OF CONTENTS (Cont'd)

	<u>PAGE</u>	
6.2.1.4	Mass and Energy Release for Postulated Secondary System Pipe Breaks Inside Containment (PWR)	6.2-27h
6.2.1.4.1	Pipe Break Blowdowns - Spectra and Assumptions	6.2-28
6.2.1.4.2	Description of Blowdown Modeling	6.2-29
6.2.1.4.3	Single Failure Analysis	6.2-30
6.2.1.5	Minimum Containment Pressure Analysis for Performance Capability Studies of Emergency Core Cooling System (PWR)	6.2-31a
6.2.1.5.1	Mass and Energy Release Data	6.2-33
6.2.1.5.2	Initial Containment Internal Conditions	6.2-33
6.2.1.5.3	Containment Volume	6.2-34
6.2.1.5.4	Active Heat Sinks	6.2-34
6.2.1.5.5	Steam-Water Mixing	6.2-34
6.2.1.5.6	Passive Heat Sinks	6.2-34
6.2.1.5.7	Heat Transfer to Passive Heat Sinks	6.2-35
6.2.1.5.8	Other Parameters	6.2-35
6.2.1.6	Testing and Inspection	6.2-35
6.2.1.6.1	Structural Acceptance Test	6.2-35
6.2.1.6.2	Preoperational Leakage Rate Test	6.2-35
6.2.1.6.3	Inservice Leakage Rate Testing	6.2-36
6.2.1.6.4	Tendon Surveillance Program	6.2-36
6.2.1.7	Instrumentation Requirements	6.2-36
6.2.2	Containment Heat Removal System	6.2-38
6.2.2.1	Design Bases	6.2-39
6.2.2.1.1	Reactor Containment Fan Cooler (RCFC) System	6.2-39
6.2.2.1.2	Containment Spray System	6.2-40
6.2.2.2	System Design	6.2-40
6.2.2.2.1	Reactor Containment Fan Cooler (RCFC) System	6.2-40
6.2.2.2.2	Containment Spray System	6.2-44
6.2.2.3	Design Evaluation	6.2-44
6.2.2.3.1	Reactor Containment Fan Cooler (RCFC) System	6.2-44
6.2.2.3.2	Containment Spray System	6.2-46
6.2.2.4	Tests and Inspections	6.2-46
6.2.2.4.1	Reactor Containment Fan Cooler (RCFC) System	6.2-46
6.2.2.4.2	Containment Spray System	6.2-48
6.2.2.5	Instrumentation Requirements	6.2-48
6.2.2.5.1	Reactor Containment Fan Cooler (RCFC) System	6.2-48
6.2.2.5.2	Containment Spray System	6.2-49
6.2.3	Secondary Containment Functional Design	6.2-49
6.2.4	Containment Isolation System	6.2-49a

TABLE OF CONTENTS (Cont'd)

	<u>PAGE</u>
6.2.4.1 Design Bases	6.2-49a
6.2.4.1.1 Criteria for Pipeline Design	6.2-52
6.2.4.1.2 Criteria for Valving Design	6.2-53
6.2.4.1.3 Criteria and Definitions for Piping Systems	6.2-53
6.2.4.1.3.1 Closed Systems	6.2-54
6.2.4.1.3.2 Open Systems	6.2-54
6.2.4.1.3.3 Functional Types of Penetrating Piping Systems	6.2-54
6.2.4.1.3.4 Isolation Valving	6.2-55
6.2.4.2 System Design	6.2-55
6.2.4.2.1 Modes of Valve Actuation	6.2-56
6.2.4.2.2 Mechanical and Electrical Redundancy	6.2-57
6.2.4.2.3 Qualification of Closed Systems as Isolation Barriers	6.2-57
6.2.4.2.4 Qualification of Valves as Isolation Barriers	6.2-57
6.2.4.2.5 Valve Closure Times	6.2-57
6.2.4.2.6 Environmental Design	6.2-58
6.2.4.2.7 Isolation Valve Testing	6.2-58
6.2.4.2.8 Exceptions to General Design Criteria 55, 56, and 57 Requirements	6.2-58
6.2.4.3 Design Evaluation	6.2-59
6.2.4.4 Tests and Inspections	6.2-60
6.2.5 Combustible Gas Control in Containment	6.2-60
6.2.5.1 Design Bases	6.2-60
6.2.5.2 System Design	6.2-62
6.2.5.2.1 Hydrogen Recombiner System Design	6.2-62
6.2.5.2.1.1 Recombiner Package Component Description	6.2-64
6.2.5.2.1.1.1 Blower Assembly	6.2-64
6.2.5.2.1.1.2 Gas Heater	6.2-64
6.2.5.2.1.1.3 Reaction Chamber	6.2-65
6.2.5.2.1.1.4 Gas Cooler	6.2-65
6.2.5.2.1.2 Electrical	6.2-66
6.2.5.2.1.3 Flowmeter	6.2-66
6.2.5.2.1.4 Alarms and Indications	6.2-66
6.2.5.2.2 Hydrogen Monitoring System Design	6.2-67
6.2.5.2.3 Containment Atmosphere Mixing System Design	6.2-68a
6.2.5.2.4 Post-LOCA Purge System Design	6.2-69
6.2.5.3 Design Evaluation	6.2-69
6.2.5.4 Testing and Inspection	6.2-74
6.2.5.5 Instrumentation Requirements	6.2-75
6.2.5.6 Materials	6.2-75
6.2.6 Containment Leakage Testing	6.2-75
6.2.6.1 Containment Integrated Leakage Rate Test	6.2-76

TABLE OF CONTENTS (Cont'd)

	<u>PAGE</u>	
6.2.6.1.1	Containment Inspection and Repair	6.2-76
6.2.6.1.2	Preoperational Tests	6.2-76
6.2.6.1.3	Containment Isolation Valve Closure	6.2-77
6.2.6.1.4	System Venting and Draining	6.2-77
6.2.6.1.5	Pressure Stabilization Period	6.2-77
6.2.6.1.6	Containment Atmosphere Stabilization	6.2-78
6.2.6.1.7	Type A Test Frequency	6.2-78
6.2.6.1.8	Test Duration	6.2-78
6.2.6.1.9	Calibration	6.2-78
6.2.6.1.10	Acceptance Criteria	6.2-78
6.2.6.1.11	Verification Tests	6.2-79
6.2.6.2	Containment Penetration Leakage Rate Test	6.2-79
6.2.6.3	Containment Isolation Valve Leakage Rate Test	6.2-82a
6.2.6.4	Scheduling and Reporting of Periodic Tests	6.2-83
6.2.6.5	Special Testing Requirements	6.2-83
6.2.7	References	6.2-83
6.3	<u>EMERGENCY CORE COOLING SYSTEM</u>	6.3-1
6.3.1	Design Bases	6.3-1
6.3.2	System Design	6.3-2
6.3.2.1	Schematic Piping and Instrumentation Diagrams	6.3-2
6.3.2.2	Equipment and Component Descriptions	6.3-3
6.3.2.3	Applicable Codes and Classifications	6.3-14
6.3.2.4	Material Specifications and Compatibility	6.3-14
6.3.2.5	System Reliability	6.3-14
6.3.2.6	Protection Provisions	6.3-21
6.3.2.7	Provisions for Performance Testing	6.3-21
6.3.2.8	Manual Actions	6.3-22
6.3.3	Performance Evaluation	6.3-34
6.3.4	Tests and Inspections	6.3-45
6.3.4.1	ECCS Performance Tests	6.3-45
6.3.4.2	Reliability Tests and Inspections	6.3-47
6.3.5	Instrumentation Requirements	6.3-49
6.3.5.1	Temperature Indication	6.3-50
6.3.5.2	Pressure Indication	6.3-50
6.3.5.3	Flow Indication	6.3-51
6.3.5.4	Level Indication	6.3-52
6.3.5.5	Valve Position Indication	6.3-53
6.3.6	References	6.3-53
APPENDIX 6.3A	<u>PROPER POSITIONING OF VALVES</u>	6.3A-1
6.4	<u>HABITABILITY SYSTEMS (Byron)</u>	6.4-1
6.4.1	Design Basis (Byron)	6.4-1
6.4.2	System Design (Byron)	6.4-2
6.4.2.1.1	Definition of Control Room	6.4-2
6.4.2.1.2	Definition of Control Room Envelope (Byron)	6.4-2
6.4.2.2	Ventilation System Design (Byron)	6.4-2
6.4.2.3	Leaktightness (Byron)	6.4-3

TABLE OF CONTENTS (Cont'd)

	<u>PAGE</u>
6.4.2.4 Interaction With Other Zones and Pressure-Containing Equipment (Byron)	6.4-3
6.4 <u>HABITABILITY SYSTEMS</u> (Braidwood)	6.4-5
6.4.1 Design Basis (Braidwood)	6.4-5
6.4.2 System Design (Braidwood)	6.4-6
6.4.2.1.1 Definition of Control Room	6.4-6
6.4.2.1.2 Definition of Control Room Envelope (Braidwood)	6.4-6
6.4.2.2 Ventilation System Design (Braidwood)	6.4-6
6.4.2.3 Leaktightness	6.4-7
6.4.2.4 Interaction With Other Zones and Pressure-Containing Equipment (Braidwood)	6.4-7
6.4.2.5 Shielding Design	6.4-9
6.4.3 System Operational Procedures	6.4-9
6.4.4 Design Evaluation	6.4-11
6.4.4.1 Radiological Protection	6.4-11
6.4.4.2 Toxic Gas Protection (Braidwood only)	6.4-15
6.4.5 Testing and Inspection (Byron)	6.4-13
6.4.6 Instrumentation Requirements (Byron)	6.4-13
6.4.5 Testing and Inspection (Braidwood)	6.4-15
6.4.6 Instrumentation Requirements (Braidwood)	6.4-15
6.4.7 References	6.4-16a
6.5 <u>FISSION PRODUCT REMOVAL AND CONTROL SYSTEMS</u>	6.5-1
6.5.1 Engineered Safety Feature (ESF) Filter Systems	6.5-1
6.5.1.1 Design Bases	6.5-1
6.5.1.1.1 Control Room Makeup Air Filter Units	6.5-1
6.5.1.1.2 Auxiliary Building Exhaust Systems	6.5-2
6.5.1.1.3 Fuel Handling Building Exhaust System	6.5-4
6.5.1.2 System Design	6.5-5
6.5.1.2.1 Emergency Makeup Air Filter Units	6.5-5
6.5.1.2.2 Auxiliary Building Exhaust System	6.5-7
6.5.1.2.3 Fuel Handling Building Exhaust System	6.5-11
6.5.1.3 Design Evaluation	6.5-16
6.5.1.3.1 Emergency Makeup Air Filter Units	6.5-16
6.5.1.3.2 Auxiliary Building Exhaust System	6.5-16
6.5.1.3.3 Fuel Handling Building Exhaust System	6.5-16
6.5.1.3.3.1 Fuel Handling Accident Inside Spent Fuel Storage Building	6.5-17
6.5.1.4 Tests and Inspections	6.5-18
6.5.1.5 Instrumentation Requirements	6.5-19
6.5.1.6 Materials	6.5-20
6.5.2 Containment Spray Systems	6.5-21
6.5.2.1 Design Bases	6.5-21
6.5.2.2 System Design (for Fission Product Removal)	6.5-22
6.5.2.3 Design Evaluation	6.5-27
6.5.2.4 Tests and Inspections	6.5-31
6.5.2.4.1 Preoperational Test Program	6.5-31
6.5.2.4.2 Reliability Tests and Inspections	6.5-31

TABLE OF CONTENTS (Cont'd)

	<u>PAGE</u>
6.5.2.5 Instrumentation Requirements	6.5-32
6.5.2.6 Materials	6.5-33
6.5.3 Fission Product Control Systems	6.5-33
ATTACHMENT A6.5 <u>IODINE REMOVAL EFFECTIVENESS EVALUATION OF CONTAINMENT SPRAY SYSTEM</u>	A6.5-1
6.6 <u>INSERVICE INSPECTION OF CLASS 2 AND 3 COMPONENTS</u>	6.6-1
6.6.1 Components Subject to Examination	6.6-1
6.6.2 Accessibility	6.6-1
6.6.3 Examination Techniques and Procedures	6.6-1
6.6.4 Inspection Intervals and Scheduling	6.6-1
6.6.5 Examination and Testing Requirements	6.6-2
6.6.6 Evaluation of Examination Results/Repair Procedures	6.6-2
6.6.7 System Pressure Testing	6.6-2

CHAPTER 6.0 - ENGINEERED SAFETY FEATURESLIST OF TABLES

<u>NUMBER</u>	<u>TITLE</u>	<u>PAGE</u>
6.1-1	Engineered Safety Features Material	6.1-12
6.1-2	Protective Coatings on Westinghouse-Supplied Equipment Inside Containmentment	6.1-14
6.1-3	NSSS Containment Paint Summary	6.1-15
6.1-4	Gas Evolution From Protective Coatings	6.1-16
6.1-5	Cables In Containmentment	6.1-17
6.2-1	Unit 1 Containmentment Peak Pressure and Temperature	6.2-86
6.2-1a	Unit 2 Containmentment Peak Pressure and Temperature	6.2-86d
6.2-2	Assumptions for Unit 1 Containmentment Analysis	6.2-87
6.2-3	Assumptions for Unit 2 Containmentment Analysis	6.2-88
6.2-4	Containment Heat Sinks - Analysis Values	6.2-89
6.2-4a	Containment Heat Sinks - Nominal Values	6.2-89b
6.2-5	Thermophysical Properties of Containmentment Heat Sinks	6.2-91
6.2-6	LOCA Sequence of Events for Double-Ended Pump Suction Break Min SI, Unit 1	6.2-92
6.2-6a	LOCA Sequence of Events for Double-Ended Pump Suction Break Min SI, Unit 2	6.2-92a
6.2-7	LOCA Sequence for Double-Ended Hot Leg Break, Unit 1	6.2-93
6.2-7a	Deleted	
6.2-8	LOCA Sequence for Double-Ended Hot Leg Break Unit 2	6.2-94
6.2-9	MSLB Accident Sequence of Events for 0.90 ft ² Split Break at 30% Power with MS Isolation Valve Failure For Unit 1 - Peak Pressure	6.2-95
6.2-9a	MSLB Accident Sequence of Events for 1.0 ft ² Split Break at 100% Power with Loss of Offsite Power and MS Isolation Valve Failure For Unit 1 - Peak Temperature	6.2-95
6.2-9b	MSLB Accident Sequence of Events for 0.83ft ² Double-Ended Rupture at 30% Power with MSIV Failure For Unit 2 - Peak Pressure	6.2-95a
6.2-9c	MSLB Accident Sequence of Events for 1.0 ft ² Double-Ended Rupture at 100% Power with LOOP and Main Steam Isolation Valve Failure For Unit 2 - Peak Temperature	6.2-95a
6.2-10	Subcompartment Nodal Description	6.2-96
6.2-11	Subcompartment Flow Path Description	6.2-97

LIST OF TABLES (Cont'd)

<u>NUMBER</u>	<u>TITLE</u>	<u>PAGE</u>
6.2-11a	Deleted	6.2-100
6.2-11b	Subcompartment Nodal Description	6.2-102
6.2-11c	Subcompartment Vent Path Description	6.2-104
6.2-12	Summary of Subcompartment Pressure Differentials	6.2-108
6.2-13	Subcompartment Mass and Energy Release Rates (DEHL)	6.2-109
6.2-14	Subcompartment Mass and Energy Release Rates (DECL)	6.2-115
6.2-15	Subcompartment Mass and Energy Release Rates (Pressurizer Spray Line)	6.2-121
6.2-16	Subcompartment Steamline Mass and Energy Release Rates	6.2-127
6.2-17	LOCA Mass and Energy Calculation System Parameters and Initial Conditions	6.2-128
6.2-17a	Deleted	
6.2-18	Safety Injection Flow Minimum Safeguards	6.2-129
6.2-18a	Safety Injection Flow Maximum Safeguards	6.2-130
6.2-19	Double-Ended Hot Leg Break Blowdown Mass and Energy Releases - Unit 1	6.2-131
6.2-20	Double-Ended Hot Leg Break Mass Balance - Unit 1	6.2-132
6.2-21	Double-Ended Hot Leg Break Energy Balance - Unit 1	6.2-133
6.2-21a	Deleted	
6.2-22	Double-Ended Pump Suction Break Minimum Safeguards Blowdown Mass and Energy Releases - Unit 1	6.2-134
6.2-22a	Deleted	
6.2-23	Double-Ended Pump Suction Break Minimum Safeguards Reflood Mass and Energy Releases Unit 1	6.2-135
6.2-23a	Deleted	
6.2-24	Double-Ended Pump Suction Break-Minimum Safeguards Principle Parameters During Reflood Unit 1	6.2-136
6.2-25	Double-Ended Pump Suction Break Minimum Safeguards Post-Reflood Mass and Energy Releases - Unit 1	6.2-137
6.2-26	Double-Ended Pump Suction Break Mass Balance Minimum Safeguards - Unit 1	6.2-138
6.2-27	Double-Ended Pump Suction Break Energy Balance Minimum Safeguards - Unit 1	6.2-139
6.2-27a	Deleted	
6.2-28	Double-Ended Pump Suction Break Maximum Safeguards Blowdown Mass and Energy Releases - Unit 1	6.2-140
6.2-29	Double-Ended Pump Suction Break Maximum Safeguards Reflood Mass and Energy Releases - Unit 1	6.2-141
6.2-30	Double-Ended Pump Suction Break-Maximum Safeguards Principle Parameters During Reflood - Unit 1	6.2-142

LIST OF TABLES (Cont'd)

<u>NUMBER</u>	<u>TITLE</u>	<u>PAGE</u>
6.2-31	Double-Ended Pump Suction Break Maximum Safeguards Post-Reflood Mass and Energy Releases - Unit 1	6.2-143
6.2-32	Double-Ended Pump Suction Break Mass Balance Maximum Safeguards - Unit 1	6.2-144
6.2-33	Double-Ended Pump Suction Break Energy Balance Maximum Safeguards - Unit 1	6.2-145
6.2-34	Double-Ended Hot Leg Break Blowdown Mass and Energy Releases - Unit 2	6.2-146
6.2-34a	Deleted	
6.2-35	Double-Ended Hot Leg Break Mass Balance - Unit 2	6.2-147
6.2-35a	Deleted	
6.2-36	Double-Ended Hot Leg Break Energy Balance - Unit 2	6.2-148
6.2-37	Double-Ended Pump Suction Break Minimum Safeguards Blowdown Mass and Energy Releases - Unit 2	6.2-149
6.2-38	Double-Ended Pump Suction Break Minimum Safeguards Reflood Mass and Energy Releases - Unit 2	6.2-150
6.2-39	Double-Ended Pump Suction Break-Minimum Safeguards Principle Parameters During Reflood - Unit 2	6.2-151
6.2-40	Double-Ended Pump Suction Break Minimum Safeguards Post-Reflood Mass and Energy Releases - Unit 2	6.2-152
6.2-41	Double-Ended Pump Suction Break Mass Balance Minimum Safeguards - Unit 2	6.2-153
6.2-42	Double-Ended Pump Suction Break Energy Balance Minimum Safeguards - Unit 2	6.2-154
6.2-43	Double-Ended Pump Suction Break Maximum Safeguards Blowdown Mass and Energy Releases - Unit 2	6.2-155
6.2-44	Double-Ended Pump Suction Break Maximum Safeguards Reflood Mass and Energy Releases - Unit 2	6.2-156
6.2-45	Double-Ended Pump Suction Break-Maximum Safeguards Principle Parameters During Reflood - Unit 2	6.2-157
6.2-46	Double-Ended Pump Suction Break Maximum Safeguards Post-Reflood Mass and Energy Releases - Unit 2	6.2-158
6.2-47	Double-Ended Pump Suction Break Mass Balance Maximum Safeguards - Unit 2	6.2-159
6.2-48	Double-Ended Pump Suction Break Energy Balance Maximum Safeguards - Unit 2	6.2-160
6.2-49	LOCA Mass and Energy Release Analysis Core Decay Heat Fraction	6.2-161

LIST OF TABLES (Cont'd)

<u>NUMBER</u>	<u>TITLE</u>	<u>PAGE</u>
6.2-50	MSLB Mass and Energy Releases for Unit 1, 0.90 ft ² Split Break at 30% Power with Main Steam Isolation Valve Failure - Offsite Power Available	6.2-179
6.2-50a	MSLB Mass and Energy Releases for Unit 1, 1.0 ft ² Split Break at 100% Power with Main Steam Isolation Valve Failure - Loss of Offsite Power	6.2-179b
6.2-50b	MSLB Mass and Energy Releases for Unit 2, 0.83 ft ² Split Break at 30% Power with Main Steam Isolation Valve Failure - Offsite Power Available	6.2-179d
6.2-50c	MSLB Mass and Energy Releases for Unit 2, 1.0 ft ² Small Double-Ended Rupture at 100% Power with Main Steam Isolation Valve Failure - Loss of Offsite Power	6.2-179f
6.2-51	Unit 1 LBLOCA Reference Transient Mass and Energy Releases for Minimum ECCS LOCA Containment Pressure	6.2-180
6.2-52	Unit 2 LBLOCA Reference Transient Mass and Energy Releases for Minimum ECCS LOCA Containment Pressure	6.2-181
6.2-53	Broken Loop Safety Injection and Accumulator Injection Spill to Containment for Minimum ECCS LOCA Containment Pressure	6.2-182
6.2-54	Active Heat Sink Data for Minimum ECCS LOCA Containment Pressure	6.2-183
6.2-55	Passive Heat Sink Data for Minimum Post- LOCA Containment Pressure	6.2-184
6.2-56	Reactor Containment Fan Cooler Design Characteristics	6.2-186
6.2-57	Single Active Failure Analysis, Reactor Containment Fan Coolers	6.2-190
6.2-58	Containment Isolation Provisions	6.2-191
6.2-59	Thermal Hydrogen Recombiner Parameters	6.2-210
6.2-60	Hydrogen Recombiner System Codes, Standards, and Regulations	6.2-211
6.2-61	Post-LOCA Purge System Components and Parameters	6.2-212
6.2-62	DELETED	6.2-214
6.2-63	DELETED	6.2-216
6.2-64	Core Fission Product Energy After 650 Full-Power Days	6.2-217

LIST OF TABLES (Cont'd)

<u>NUMBER</u>	<u>TITLE</u>	<u>PAGE</u>
6.2-65	Fission Product Decay Deposition in Sump Solution	6.2-218
6.2-66	Liner and Concrete Design Temperatures	6.2-219
6.2-67	Subcompartment Volume Description	6.2-220
6.3-1	Emergency Core Cooling System Component Parameters	6.3-54
6.3-2	ECCS Relief Valves Data	6.3-57
6.3-3	Motor-Operated Isolation Valves in ECCS	6.3-58
6.3-4	Materials Employed for Emergency Core Cooling System Components	6.3-60
6.3-5	Single Active Failure Analysis for Emergency Core Cooling System Components	6.3-62

LIST OF TABLES (Cont'd)

<u>NUMBER</u>	<u>TITLE</u>	<u>PAGE</u>
6.3-6	Emergency Core Cooling System Recirculation Piping Passive Failure Analysis	6.3-65
6.3-7	Sequence of Switchover Operations (Based On No Single Failures)	6.3-66
6.3-8	Emergency Core Cooling System Shared Functions Evaluation	6.3-69
6.3-9	Normal Operating Status of Emergency Core Cooling System Components for Core Cooling	6.3-70
6.3-10	Failure Mode and Effects Analysis - Emergency Core Cooling System Active Components	6.3-71
6.3-11	ECCS Active Components	6.3-85
6.3-12	Deleted	6.3-89
6.3-13	Deleted	6.3-91
6.3-14	ECCS Air Operated Valves	6.3-93
6.3-15	Deleted	6.3-94
6.3-16	ECCS Vent Valves Located Inside Containment	6.3-96
6.3-17	Permanent Design ECCS and CS System Void Locations	6.3-97
6.4-1	Expected Dose to Control Room Personnel at Byron Station Following a Loss-of- Coolant Accident (LOCA)	6.4-17
6.4-1a	Principal Assumptions Used In Control Room Habitability Calculations (Byron)	6.4-18
6.4-1	Expected Dose to Control Room Personnel at Braidwood Station Following a Loss- of-Coolant Accident (LOCA)	6.4-19
6.4-1a	Principal Assumptions Used In Control Room Habitability Calculations (Braidwood)	6.4-20
6.5-1	Single Active Failure Analysis - Containment Spray System	6.5-34
6.5-2	Fuel Handling Accident Inside Spent Fuel Storage Building	6.5-35
6.5-3	Deleted	6.5-36
6.5-4	Deleted	6.5-37
6.5-5	Nonaccessible Areas of the Auxiliary Building	6.5-38

CHAPTER 6.0 - ENGINEERED SAFETY FEATURESLIST OF FIGURES

<u>NUMBER</u>	<u>TITLE</u>
6.2-1	LOCA Containment Pressure Response for Double Ended Pump Suction Break Minimum SI Unit 1
6.2-1a	Deleted
6.2-2	LOCA Containment Temperature Response for Double Ended Pump Suction Break Minimum SI Unit 1
6.2-2a	Deleted
6.2-3	LOCA Containment Pressure Response for Double Ended Pump Suction Break Maximum SI Unit 1
6.2-4	LOCA Containment Temperature Response for Double Ended Pump Suction Break Maximum SI Unit 1
6.2-5	LOCA Containment Pressure Response for Double Ended Hot Leg Break Unit 1
6.2-6	LOCA Containment Temperature Response for Double Ended Hot Leg Break Unit 1
6.2-6a	Deleted
6.2-7	LOCA Containment Pressure Response for Double Ended Pump Suction Break Minimum SI Unit 2
6.2-7a	Deleted
6.2-8	LOCA Containment Temperature Response for Double Ended Pump Suction Break Minimum SI Unit 2
6.2-8a	Deleted
6.2-9	LOCA Containment Pressure Response for Double Ended Pump Suction Break Maximum SI Unit 2
6.2-10	LOCA Containment Temperature Response for Double Ended Pump Suction Break Maximum SI Unit 2
6.2-11	LOCA Containment Pressure Response for Double Ended Hot Leg Break Unit 2
6.2-12	LOCA Containment Temperature Response for Double Ended Hot Leg Break Unit 2
6.2-12a	Deleted

LIST OF FIGURES (Cont'd)

<u>NUMBER</u>	<u>TITLE</u>
6.2-13	MSLB Containment Pressure Response, Composite Curve, Unit 1
6.2-13a	MSLB Containment Pressure Response for 0.83 ft ² Split Break at 30% Power and Main Steam Isolation Valve Failure, Unit 1
6.2-13b	MSLB Containment Pressure Response for 1.0-ft ² DER at 102% Power with LOOP and Main Steam Isolation Valve Failure, Unit 1
6.2-13c	MSLB Containment Pressure Response, Composite Curve, Unit 2
6.2-13d	MSLB Containment Pressure Response for 0.83 ft ² Split Break at 30% Power and Main Steam Isolation Valve Failure Unit 2
6.2-13e	Deleted
6.2-14	MSLB Containment Temperature Response Composite Curve Unit 1
6.2-14a	MSLB Containment Temperature Response for 0.81 ft ² Split Break at 100% Power with LOOP and Main Steam Isolation Valve Failure Unit 1
6.2-14b	Deleted
6.2-14c	MSLB Containment Temperature Response Composite Curve Unit 2
6.2-14d	Deleted
6.2-14e	Deleted
6.2-15	MSLB Containment Temperature Response for 1.00 ft ² DER at 100% Power with LOOP and Main Steam Isolation Valve Failure Unit 2
6.2-16	Deleted
6.2-16a	Deleted
6.2-16b	Deleted
6.2-16c	Deleted
6.2-17	Deleted
6.2-18	Containment Subcompartment Nodalization Diagram
6.2-18a	Nodalization Schematic
6.2-19	Loop Compartment and Upper Compartment Pressure Transient for Worst Case Break Compartment (Element 3) Having a DEHL Break
6.2-20	Loop Compartment and Upper Compartment Pressure Transient for Worst Case Break Compartment (Element 3) Having a DECL Break

LIST OF FIGURES (Cont'd)

<u>NUMBER</u>	<u>TITLE</u>
6.2-21	Upper Pressurizer Cubicle and Upper Compartment Pressure Transient For Spray Line Break (Element 28)
6.2-22	Steamline Compartment and Upper Compartment Pressure Transient for Steamline Break (Element 25)
6.2-23	Steamline Compartment and Upper Compartment Pressure Transient for Steamline Break (Element 26)

LIST OF FIGURES (Cont'd)

<u>NUMBER</u>	<u>TITLE</u>
6.2-24	DELETED
6.2-24a	Containment Pressure for ECCS LBLOCA (Unit 1)
6.2-24b	Containment Pressure for ECCS LBLOCA (Unit 2)
6.2-25	One Fan Cooler Estimated Heat Removal Capacity for Containment Response Analysis (Byron)
6.2-25	One Fan Cooler Estimated Heat Removal Capacity for Containment Response Analysis (Braidwood)
6.2-25a	DELETED
6.2-26	Heat Transfer Coefficient Versus Time for ECCS LBLOCA Reference Transient
6.2-27	Containment Air Temperature Versus Time for ECCS LBLOCA Reference Transient
6.2-28	Containment Penetration Isolation Valve Test Connections
6.2-29	Isolation Valve Schemes
6.2-30	Instrumentation Penetration Scheme
6.2-31	DELETED
6.2-32	DELETED
6.2-33	Total Residual Decay Power as a Fraction of Operating Power vs. Time
6.2-34	Beta, Gamma, and Beta Plus Gamma Energy Release Rates vs. Time (TID-14844 Based)
6.2-34a	Integrated Energy Release of Beta, Gamma, and Beta Plus Gamma vs. Time
6.2-35	DELETED
6.2-36	DELETED
6.2-37	Fuel Transfer Penetration
6.2-38	Piping Volumes in the Main Steam System
6.2-39	Piping Volumes in the Main Feedwater System (Between Control Valves and Steam Generators) - Unit 1
6.2-40	Piping Volumes in the Main Feedwater System (Between Control Valves and Steam Generators) - Unit 2
6.3-1	Deleted
6.3-2	Deleted
6.3-2a	Emergency Core Cooling System
6.3-3	Residual Heat Removal Pump Performance Curve (without uncertainty)

LIST OF FIGURES (Cont'd)

<u>NUMBER</u>	<u>TITLE</u>
6.3-4	Centrifugal Charging Pump Performance Curve (without uncertainty)
6.3-5	Safety Injection Pump Performance Curve (without uncertainty)
6.3-6	Deleted
6.3-7	Deleted
6.3-8A	Recirculation Sump Details
6.3-8B	Sump outline / Trash Rack Details
6.4-1	Deleted
6.4-2	Isometric View of Control Room
6.4-3	Diagrammatic Representation of Radioactive Sources for Protected Area of Control Room During a LOCA
6.4-4	Diagrammatic Representation of Total Control Room LOCA Dose
6.4-5	Simplified Control Room HVAC System Diagram - Normal Operation
6.4-6	Simplified Control Room HVAC System Diagram - Emergency Operation
6.4-7	Simplified Control Room HVAC System Diagram - Emergency Operation (Alternate)
6.4-8	Simplified Control Room HVAC System Diagram - Makeup HEPA Filter Testing Operation (Byron)
6.5-1	Deleted
6.5-2	Deleted
6.5-3	Deleted
6.5-4	Deleted
6.5-5	Nozzle Spraying Downward
6.5-6	Nozzle Spraying Horizontally
6.5-7	Nozzle Spraying Downward at 45°
6.5-8	Pressure Drop vs. Flow, 1713A Nozzle
6.5-9	Spray Envelope Reduction Factor

CHAPTER 6.0 - ENGINEERED SAFETY FEATURESDRAWINGS CITED IN THIS CHAPTER*

*The listed drawings are included as "General References" only; i.e., refer to the drawings to obtain additional detail or to obtain background information. These drawings are not part of the UFSAR. They are controlled by the Controlled Documents Program.

DRAWING*	SUBJECT
M-5	General Arrangement Roof Plan Units 1 & 2
M-6	General Arrangement Main Floor At El. 451'-0" Units 1 & 2
M-7	General Arrangement Mezzanine Floor At El. 426'-0" Units 1 & 2
M-8	General Arrangement Grade Floor At El. 401'-0" Units 1 & 2
M-9	General Arrangement Floor Plan At El. 383'-0" Units 1 & 2
M-10	General Arrangement Basement Floor At El. 364'-0" Units 1 & 2
M-11	General Arrangement Floor Plan At El. 346'-0" Units 1 & 2
M-12	General Arrangement Radwaste/Service Building Units 1 & 2
M-13	General Arrangement Fuel Handling Building Units 1 & 2
M-14	General Arrangement Section "A-A" Units 1 & 2
M-15	General Arrangement Section "B-B" Units 1 & 2
M-16	General Arrangement Section "C-C" and "D-D" Units 1 & 2
M-17	General Arrangement Section "E-E" Units 1 & 2
M-18	General Arrangement Section "F-F" Units 1 & 2
M-46	Diagram of Containment Spray System Unit 1
M-61	Diagram of Safety Injection System Unit 1
M-62	Diagram of Residual Heat Removal System Unit 1
M-95	Diagram of Auxiliary Building HVAC (VA) Systems Units 1 & 2
M-103	Diagram of Primary Containment Ventilation (VP) System Unit 1
M-104	Diagram of Primary Containment Ventilation (VP) System Unit 2
M-105	Diagram of Primary Containment Purge, Pressurization, and Vacuum Relief (VQ, VP) System Unit 1
M-106	Diagram of Primary Containment Purge, Pressurization, and Vacuum Relief (VQ, VP) System Unit 2
M-197	Reactor Containment Penetrations Sleeves Schedule
M-535	Containment Spray System Plans and Sections
M-1033-13	Control Room Envelope (CRE)
M-1323-1	Auxiliary Building Ventilation Plan Floor Plan Elevation 451'0"
M-1323-8	Auxiliary Building Ventilation System Floor Plan Elevation 451'0"

CHAPTER 6.0 - ENGINEERED SAFETY FEATURES6.0 ENGINEERED SAFETY FEATURES

The engineered safety features of the Byron and Braidwood Stations are those systems whose actions are essential to a safety action required to mitigate the consequences of postulated accidents. The features can be divided into five general groups as follows: containment systems, emergency core cooling systems (ECCS), habitability systems, fission product removal, and control systems and other systems. The engineered safety features, listed above, are discussed in detail throughout this chapter.

6.1 ENGINEERED SAFETY FEATURES MATERIALS6.1.1 Metallic Materials6.1.1.1 Materials Selection and Fabrication

Material specifications used for the principal pressure retaining applications in the components of the engineered safety features (ESF) are listed in Table 6.1-1. In some cases, Table 6.1-1 may not be totally inclusive of the material specifications used in the listed applications; however, the listed specifications are representative of those materials utilized. All of the materials used conform to the requirements of the ASME Boiler and Pressure Vessel Code, Section III, plus applicable and appropriate addenda and code cases.

The welding materials used for joining the ferritic base materials of the ESF conform to or are equivalent to ASME Material Specifications SFA 5.1, 5.5, 5.13, 5.17, 5.18, 5.20, 5.23, and 5.28. The welding materials used for joining nickel-chromium-iron alloy in similar base material combination and in dissimilar ferritic or austenitic base material combination conform to ASME Material Specifications SFA 5.11 and 5.14. The welding materials used for joining the austenitic stainless steel base materials conform to ASME Material Specifications SFA 5.4, 5.9, and 5.30. These materials are tested and qualified to the requirements of the ASME Code, Section III and Section IX rules, and are used in procedures which have been qualified to these same rules.

Parts of components in contact with borated water are fabricated of, or clad with austenitic stainless steel or equivalent corrosion resistant material. The integrity of the safety-related components of the ESF is maintained during all stages of component manufacture. Austenitic stainless steel is used in the final heat treated condition as required by the respective ASME Code Section II material specification for the particular type or grade of alloy. Furthermore, austenitic stainless steel materials used in the ESF components are handled, protected, stored, and cleaned according to recognized

and accepted methods which are designed to minimize contamination which could lead to stress corrosion cracking; these controls are stipulated in Westinghouse process specifications, which are discussed in Subsection 5.2.3. Additional information concerning austenitic stainless steel, including the avoidance of sensitization and the prevention of intergranular attack, can be found in Subsection 5.2.3. No cold worked austenitic stainless steels having yield strengths greater than 90,000 psi are used for components of the ESF supplied by Westinghouse.

Components within the containment that would be exposed to core cooling water and containment sprays in the event of a loss-of-coolant accident utilize materials listed in Table 6.1-1. These components are manufactured primarily of stainless steel or other corrosion resistant material. The integrity of the materials of construction for ESF equipment when exposed to post design-basis accident (DBA) conditions has been evaluated. Post DBA conditions were conservatively represented by test conditions. The test program (Reference 1) performed by Westinghouse considered spray and core cooling solutions of the design chemical compositions, as well as the design chemical compositions contaminated with corrosion and deterioration products which may be transferred to the solution during recirculation. The effects of sodium (free caustic), chlorine (chloride), and fluorine (fluoride) on austenitic stainless steels were considered. Based on this investigation, as well as testing by ORNL and others, the behavior of austenitic stainless steels in the post DBA environment will be acceptable. No cracking is anticipated on any equipment even in the presence of postulated levels of contaminants, provided the core cooling and spray solution pH is maintained at an adequate level. The inhibitive properties of alkalinity (hydroxyl ion) against chloride cracking and the inhibitive characteristic of boric acid on fluoride cracking have been demonstrated. Coatings on exposed surfaces within the containment are not subject to breakdown under exposure to the spray solution and can withstand the temperature and pressure expected in the event of a loss-of-coolant accident.

The majority of the coating work inside containment complies with the guidelines of Regulatory Guide 1.54, "Quality Assurance Requirements for Protective Coatings Applied to Water-Cooled Nuclear Power Plants." The majority of the material manufactured and applied conforms to requirements of ANSI N101.2, "Protective Coatings (Paints) for Light Water Nuclear Reactor Containment Facilities," ANSI N5.12, "Protective Coatings (Paints) for the Nuclear Industry," and ANSI N101.4, "Quality Assurance for Protective Coatings Applied to Nuclear Facilities" (see Subsection 6.1.2).

Information concerning the degree to which the materials used comply with requirements for control of ferrite content in stainless steel weld metal, cleaning of fluid systems and

associated components, and control of the use of sensitized stainless steels can be found in Appendix A.

6.1.1.2 Composition, Compatibility, and Stability of Containment and Core Spray Coolants

The containment spray system is designed to provide a sufficient quantity of 30% to 36% sodium hydroxide to the containment to form a minimum of 8.0 pH solution when combined with the spilled reactor coolant water, the safety injection accumulator inventory, and the refueling water storage tank inventory. Refer to Subsection 6.5.2 for information on pH changes during system operation. The probability of stress-corrosion cracking of austenitic stainless steel components is therefore minimized by maintaining the long-term sump pH between 8.0 and 10.5.

Most components in the containment are fabricated of austenitic stainless steel. These materials are compatible with the NaOH solution, with the exception of galvanized steel and aluminum. To prevent degradation of the sodium hydroxide, an inert gas is maintained within the spray additive tank. A relief valve is provided to prevent overpressurization of the tank.

The vessels used for storing ESF coolants include the accumulators, the containment spray additive (sodium hydroxide) tank, and the refueling water storage tank.

The ESF coolant is stored in a stainless-steel-lined concrete refueling water storage tank. The chloride ion concentration of borated water coolant stored in this tank normally is less than 0.15 ppm, therefore stress corrosion cracking of the lined stainless steel or ESF components through which the coolant circulates is very unlikely.

The accumulators are carbon steel clad with austenitic stainless steel. Because of the corrosion resistance of these materials, significant corrosive attack on the storage vessels is not expected.

The accumulators are vessels filled with borated water and pressurized with nitrogen gas. The nominal boron concentration is 2200 to 2400 ppm. Samples of the solution in the accumulators are taken periodically for checks of boron concentration. Principal design parameters of the accumulators are listed in Table 6.3-1.

The refueling water storage tank is a source of borated cooling water for injection. The nominal boron concentration is 2300-2500 ppm, which is below the solubility limit at freezing. The temperature of the refueling water is maintained above freezing. Further information on the refueling water

storage tanks is given in Subsection 3.8.4.1.3, Sections 6.3 and 6.5, and the Technical Specifications.

6.1.2 Organic Materials

Criteria have been developed for selection and application of protective coatings for structures and components inside containment. The coatings on most of the structure and components conform to this criteria and, as a result, will remain intact and protect exposed surfaces during and after any postulated event. The limited amount of undocumented/unqualified coatings have been identified and an evaluation of the potential effect of coatings failure on containment ECCS sump functionality has been completed. This evaluation demonstrates that coating failure will not result in unacceptable sump performance.

The following coating systems, which apply to the containment building, have been used, and each of these systems provides corrosion protection for the exposed metal and concrete surfaces and facilitates the decontamination process:

a. Steel Containment

1. System Description - A prime coat of inorganic zinc-rich coating and a finish coat of phenolic organic coating with the exception that the finish coat at Braidwood is limited to a height of 8 feet 0 inch above the operating floor (elevation 426 feet 0 inch).
2. System Thickness - Minimum dry film thicknesses are as follows:
 - a) Prime Coat - 3 mils minimum, 6 mils maximum;
 - b) Finish Coat - 4 mils minimum, 6 mils maximum; and
 - c) Total System Thickness - 7 mils minimum, 12 mils maximum.
3. Manufacturers and coatings
 - a) Inorganic zinc - rich primer carbo zinc 11SG inorganic zinc - Carboline Company or equivalent.
 - b) Phenolic organic finish coat - Phenoline 305 finish - Carboline Company or equivalent.

b. Concrete walls and steel embedded in walls

1. System description - one epoxy surface coat applied over formed concrete wall and ceiling surfaces and over concrete masonry wall surfaces, and one phenolic finish coat applied over the surfacer coat.
2. Uses - indoor surfaces of concrete walls and ceilings, concrete masonry walls and metalwork that require protection from a corrosive atmosphere, chemical attack and wear, irradiation, radioactive materials and the decontamination processes involved, and which provides for general maintenance service and moderate impact and abrasion service.
3. System thickness - minimum dry film thicknesses are as follows:
 - a) Surfacer coat - applied to a reasonably smooth, sealed surface - about 20 to 30 mils.
 - b) Finish coat - 4 to 6 mils.
 - c) Total system thickness - 24 to 36 mils.
4. Manufacturers and coatings
 - a) Typical surfacer coat - Surfacer 195 - Carboline Company or equivalent.
 - b) Typical finish coat - Phenoline 305 finish - Carboline Company or equivalent.

c. Concrete floors and steel embedded in floors

1. System description - one epoxy prime coat and one phenolic finish coat applied over finished concrete floors and the miscellaneous steel embedded in the floor.
2. Uses - indoor surfaces or concrete floors that require protection from a corrosive atmosphere, chemical attack and wear, irradiation, radioactive materials and the decontamination processes involved, and which provides for general maintenance service and heavy impact and abrasion service.
3. System thickness - minimum dry film thicknesses shall be as follows:

- a) Prime Coat - 20 to 30 mils.
 - b) Finish Coat - 6 to 8 mils.
 - c) Total system thickness - 26 to 38 mils.
4. Manufacturers and coatings - same as specified for prime coats and finish coats for concrete walls.
- d. Curing Procedures for All Coating Systems

Ambient, but not less than 60°F. Properties of the coating systems are as follows:

- 1. Dry Density:
 - a) Coating system for steel containment - 0.148 psf.
 - b) Coating system for concrete walls - 0.265 psf.
 - c) Coating system for concrete floors - 0.265 psf.
- 2. Heat transfer through the various materials comprising the primary containment structure will be essentially in direct proportion to the resistance indicated in the following tabulation:

<u>Part of Structure</u>	<u>Thickness (in)</u>	<u>Resistance (R)</u>	<u>Percentage of Total R Value (%)</u>
Coating System	0.007	0.00280	0.44
Steel Liner Plate	0.250	0.00074	0.06
Concrete Walls	42.000	5.60000	88.00
Air (Both Sides)		0.78000	11.50
Totals	42.257	6.38354	100.00

- 3. Approximate surface area covered by each coating system:
 - a) Steel Containment - 104,000 ft²,
 - b) Concrete Walls and Embedded Steel - 86,200 ft², and
 - c) Concrete Floors and Embedded Steel - 31,100 ft².

The coating systems that are used on components in the NSSS vendor's scope of supply are given in Table 6.1-3.

Quantification of significant amounts of protective coatings on Westinghouse supplied components located inside the containment building is given in Table 6.1-2; the painted surfaces of Westinghouse supplied equipment comprise a small percentage of the total painted surfaces inside containment.

For large equipment requiring protective coatings (specifically itemized in Table 6.1-2), Westinghouse specifies or approves the type of coating systems utilized; requirements with which the coating system must comply are stipulated in Westinghouse process specifications, which supplement the equipment specifications. For these components, the generic types of coatings used are zinc, rich silicate, or epoxy based primer with or without chemically-cured epoxy or epoxy modified phenolic top coat.

The remaining equipment requires protective coatings on much smaller surface areas and is procured from numerous vendors; for this equipment Westinghouse specifications require that high quality coatings be applied using good commercial practices and in accordance with conventional industry standards. Table 6.1-2 includes identification of this equipment and total quantities of protective coatings on such equipment.

Protective coatings for use in the reactor containment have been evaluated as to their suitability in post-DBA conditions. Tests have shown that certain epoxy and modified phenolic systems are satisfactory for in-containment use. This evaluation (Reference 2) considered resistance to high temperature and chemical conditions anticipated during a LOCA, as well as high radiation resistance.

Information regarding quality assurance requirements for protective coatings is discussed in Appendix A. Further compliance information has been submitted to the NRC for review (via letter NS-CE-1352 dated February 1, 1977, to C. J. Heltemes, Jr., Quality Assurance Branch, NRC, from C. Eicheldinger, Westinghouse PWRSD, Nuclear Safety Dept.) and accepted (via letter dated April 27, 1977, to C. Eicheldinger from C. J. Heltemes, Jr.).

The majority of coatings inside containment comply with the guidelines of Regulatory Guide 1.54, "Quality Assurance Requirements for Protective Coatings Applied to Water-Cooled Nuclear Power Plants." The coating material conforms to requirements of ANSI N101.2, "Protective Coatings (Paints) for Light Water Nuclear Reactor Containment Facilities," ANSI N5.12, "Protective Coatings (Paints) for the Nuclear Industry," and ANSI N101.4, "Quality Assurance for Protective Coatings Applied to Nuclear Facilities."

A review has been completed of the coatings qualification in each containment. Braidwood 1 was found to have the largest

amount of undocumented or unqualified coatings and was used for all subsequent evaluation. The quantity of unqualified coatings was then assumed to fail and become detached. Conservative assumptions were utilized for the fragment size and specific gravity in calculating the transport of fragments to the sump. The results demonstrated that a relatively small portion of the failed coatings would reach the sump screens. The resulting blockage was evaluated with respect to pump NPSH requirements and found to cause only an insignificant change in the NPSH margin.

The Category 1 equipment coating, as described in letter NS-CE-1352 dated February 1, 1977, meets ANSI N101.2, and meets the alternate QA program on control of paint as described in WCAP-8370. The range of coating thicknesses for this equipment is 5.5 mils to 8.0 mils.

6.1.2.1 Formation of Combustible Gas Mixtures from Organic Materials and Protective Coating

The protective coating systems inside the containment are described in detail in Subsection 6.1.2. Based on the information given in that subsection, the resultant amounts of gas evolved are listed in Table 6.1-4. Temperature and chemical effects on the generation of hydrogen and methane gas from these coatings are expected to be minimal. With a containment volume of 2.81×10^6 ft³, the concentration of generated gas is less than 0.024% of the containment volume. Therefore, the coating systems used inside containment, which are qualified to ANSI N101.2, will not create solid debris or significant amounts of hydrogen or methane gas due to radiolytic and chemical decomposition at DBA conditions. Hydrogen generation from zinc based coatings is discussed in Subsection 6.2.5.

Charcoal and oil present inside the containment are located within filter housings and mechanical components, respectively. Thus, charcoal and oil are not exposed to the containment spray and will not create debris nor generate hydrogen and methane gas.

Other organic materials within the primary containment are the insulation and jacket materials of power, control and instrumentation cables. Ethylene propylene rubber (EPR)/hypalon (chlorosulfonated polyethylene) are used for the construction of insulation/jackets for the Okonite power and control cables. Ethylene propylene diene monomer (EPDM)/hypalon are used for the construction of the insulation/jacket for the Samuel Moore instrumentation cables. Power, control, and instrumentation cables purchased under Nuclear Electrical Material Standard N-EM-0035 (representing cables procured and installed after the initial fuel load) may be constructed of other approved insulation and jacket materials. The quantity of hydrogen and methane from this source is a small fraction of that from other sources.

The quantity (weight and volume) of uncovered cable and cable in conduit or closed cable trays are as follows:

a. Uncovered

Weight (W) = 11,359.31 pounds

Volume (V) = 81.96 cubic feet

b. Covered

W = 75,061.53 pounds

V = 586.49 cubic feet.

A breakdown of cable diameters and associated conductor cross sections is shown on Table 6.1-5.

The insulation and jacket materials are also indicated on Table 6.1-5.

There is no wood or asphalt inside the containment.

6.1.3 Postaccident Chemistry

In the event of an accident, sodium hydroxide and boric acid solutions will be present in the containment sump; the presence of sodium hydroxide in the sump solution will reduce the probability of stress corrosion cracking of austenitic stainless steels by maintaining the long-term sump solution pH at 8.0 or greater.

There are two independent safety grade sumps in the containment which are used to recycle ESF fluids. The only significant source of low pH fluids is a possible leak of borated reactor coolant. The boric acid content of this water is very low, and as a result, the pH of the coolant will be only slightly less than 7.0. In the event of a LOCA, the reactor coolant pH will be increased by the addition of NaOH in the containment spray. A sufficient quantity of NaOH is added to maintain the pH of liquids in the containment at 8.0 or greater. This pH level can be maintained even in the event of a maximum break size LOCA, and the concurrent failure of one of the two safety grade containment spray systems. The containment spray systems are designed so that each division fully covers the containment, thereby ensuring that all reactor coolant spillage, when combined with the spray, has a minimum pH of 8.0.

6.1.3.1 Steamline Break Inside Containment

In the event of a main steamline break inside the containment concurrent with failure of the isolation valve to close in the

B/B-UFSAR

faulted steamline, there would be backflow from piping which is external to the containment. Low steamline pressure setpoints would be reached within approximately 5 seconds after the break occurs, and the three remaining main steamline isolation valves and the main feedwater isolation valves would require an additional 5 seconds for closure. In addition, steam would be released from the steam generator via a 1.1-ft² flow restrictor for Unit 1 and a 1.4-ft² flow restrictor for Unit 2 located within the vessel discharge nozzle. Peak containment pressure resulting from this break is high enough to cause actuation of containment spray and caustic education. After the type of break has been ascertained, the caustic addition can be secured by operator action. Once the containment pressure has decreased below 15 psig, the CS pumps may also be secured.

Although there may be up to 1.50 ppm of ammonia in the steam resulting from decomposition of morpholine or from direct feed of ammonia, this has no significant effect upon pH of condensed steam containment spray mixture as it accumulates in the containment sump.

6.1.3.2 Main Feedwater Line Break Inside Containment

In the event of a main feedwater line failure inside the containment concurrent with failure of the isolation valve to close in the faulted line, but with the feedwater regulator valve located in the turbine building assumed to close within 10 seconds after the break occurs, the resulting peak containment pressure will differ between Unit 1 and Unit 2 due to feedwater design differences. Unit 1 has a larger break size due to the feeding/J-tube arrangement in the feedwater system. Unit 2 has a preheater design with a flow restricting orifice. For Unit 1, the containment spray system may actuate on high containment pressure; however, the integrated energy into containment for a Unit 1 main feedline break is less than the energy associated with a main steamline break. Accordingly, the containment spray would run for less time following a main feedline break, and the quantity of liquid and the impact on the maximum value of pH is bounded by the main steamline break evaluation for Unit 1. For Unit 2, the peak containment pressure response will be less than the pressure at which containment spray is actuated. Therefore, for Unit 2 the accumulation of liquid in the containment basement will be the amount of liquid discharged from the feedwater line, plus water and steam released from the feedwater nozzle via a restricting orifice located in the nozzle. It is assumed that all four reactor containment fan coolers will condense flashed steam at their total design rate of 6,840 lb/min. The following chemical composition of the liquid is expected:

Free hydroxide, ppm as CaCO ₃	less than 0.15
Ammonia, ppm	less than 0.25

In addition, there will be trace quantities of other substances such as silica, sodium and chlorides.

6.1.3.3 Loss-of-Coolant Accident

In the event of a pipe break of a reactor coolant loop, both safety injection and containment spray will be initiated. The pH of the final sump solution is independent of the number of trains of ECCS and CS pumps in operation. The final sump pH is determined by the quantity of water and concentration of boron in the RWST, the RCS, and the SI accumulators and the quantity of water and concentration of NaOH educted from the containment spray additive tank. The pH of the spray solution is determined by the CS pump suction source and the quantity of NaOH educted from the spray additive tank. The systems function in the same manner regardless of whether one or two ECCS/containment spray trains are in operation. The residual heat removal pumps will be semiautomatically transferred to the recirculation mode when the refueling water storage tank reaches the Lo-2 level setpoint. The charging and safety injection pumps are then manually aligned for the recirculation mode. The containment spray pumps will continue to operate with suction from the RWST until the RWST reaches the Lo-3 level setpoint. The operator will then manually align the containment spray pump suction from the RWST to the recirculation sump. Caustic addition will continue until the spray additive tank reaches the Lo-2 level regardless of CS pump suction source. This ensures that the final sump solution pH will always be between 8.0 and 10.5. The spray pH may exceed the upper EQ limit of 10.5 depending on the spray additive tank NaOH concentration. Refer to Subsection 6.5.2 for further information on spray pH.

6.1.4 References

1. WCAP-7803, "Behavior of Austenitic Stainless Steel in Post Hypothetical Loss of Coolant Environment."
2. Picone, L. F., "Evaluation of Protective Coatings for Use in Reactor Containment," WCAP 7825, December 1971.
3. Bolt, R., and Carroll, J., "Radiation Effects on Organic Materials," Academic Press, 1963.
4. Zhiklarer, V., et al., "Study of Radiolysis of Epichlorohydrin by an Electrical Conducting Method," (Institute of Physical Chemistry, Kier, 1973), abstract only in Nuclear Science Abstracts, 28, No. 12, Item 29672, 1973.

TABLE 6.1-1

ENGINEERED SAFETY FEATURES MATERIALSValves

Bodies	SA182 Type F316 or SA351 Gr CF8 or CF8M
Bonnets	SA182 Type F316 or SA351 Gr CF8 or CF8M
Discs	SA182 Type F316 or SA564 Gr 630 or SA351 Gr CF8 or CF8M
Pressure retaining bolting	SA453 Gr 660
Pressure retaining nuts	SA453 Gr 660 or SA194 Gr 6

Ball Valves (≤ 1 " Nominal Pipe Size and Approved for Specific Application)

Bodies	A-479 Type 316
Flanges	A-479 Type 316
Ball	A-276 Type 316
Pressure retaining bolting	SA-453 Gr 660
Pressure retaining nuts	SA-194 Gr 6

Auxiliary Heat Exchangers

Heads	SA240 Type 304
Nozzle necks	SA240 Type 304
Tubes	SA249 Type 304
Tube sheets	SA515 Gr 70 with Stainless Steel Cladding A-8 Analysis
Shells	SA240 Type 304
Flange	SA182 Gr F304

TABLE 6.1-1 Cont'd

Auxiliary Pressure Vessels, Tanks, Filters, etc.

Shells and heads	SA351 Gr CF8A, SA240 Type 304, SA264 Clad Plate of SA537 Gr B with SA240 Type 304 Clad and Stainless Steel Weld Overlay A-8 Analysis
Flanges and nozzles	SA182 Gr F304, SA350 Gr LF2 with SA240 Type 304 and Stainless Steel Weld Overlay A-8 Analysis
Piping	SA 312 Type 304, Type 316 or SA 376 Type 304, Type 316
Containment Recirculation Sump Screen	SA-240 TP 304

TABLE 6.1-1 (Cont'd)

Pipe fittings	SA403 WP304 Seamless
Closure bolting and nuts	SA193 Gr B7 and SA194 Gr 2H
<u>Auxiliary Pumps</u>	
Pump casing and heads	SA351 Gr CF8 or CF8M, SA182 Gr F304 or F316
Flanges and nozzles	SA182 Gr F304 or F316k SA403 Gr WP316L Seamless
Stuffing or packing box cover	SA351 Gr CF8 or CF8M, SA240 Gr 304 or 316
Closure bolting	SA193 Gr B7, Br B8 or SA453 Gr 660
Closure nuts	SA194 Gr 8
Tubing	SA213 Type 304, 304L, 316 or 316L
Pipe	SA312 Type 304, 304L, 316 or 316L
<u>Piping</u>	
Pipe	SA312, Type 304 SA358, Type 304 SA376, Type 304
Fittings	SA182, GR F304 SA403, GR WP304
Flanges	SA182, GR F304 SA182, GR F304
Bolting	SA193, GR B7

TABLE 6.1-2

PROTECTIVE COATINGS ON WESTINGHOUSE-SUPPLIED EQUIPMENTINSIDE CONTAINMENT

COMPONENT	PAINTED SURFACE AREA (ft ²)
Reactor coolant pump motors	1600
Accumulator tanks	5400
Manipulator crane	3100
Other refueling equipment	1100
Remaining equipment	<1300

(such as valves, auxiliary tanks and heat exchanger supports, transmitters, alarm horns, and small instruments)

TABLE 6.1-3

NSSS CONTAINMENT PAINT SUMMARY

PAINT TYPE	MANUFACTURER'S DESIGNATION	SURFACE AREA COVERED (ft ²)	DRY DENSITY (mil/ft ²)	CURING PROCEDURE
Polyamide	Amercote No. 66	5,000	0.009*	Finish coat dry for 7 days at 70°F with air circulation
Organic modified silicone base with low chloride content	Carboline 4674* (black)	18,300	0.007*	Air dry in 2-4 hours hours at 75°F coating cures in-service

* Coatings are generally covered by insulation.

TABLE 6.1-4

GAS EVOLUTION FROM PROTECTIVE COATINGS

PROTECTIVE COATING	QUANTITY (lb)	ORGANIC: VEHICLES (%)	G-VALUE*	GAS EVOLVED (ft ³)**
Modified Phenolic finish coat - Phenoline 305	1.54 x 10 ⁴	66	0.08	61
Surfacer coat - Epoxy Polyamide Surfacer 195	3.29 x 10 ⁴	34	0.8	670

*G-Value = Molecules of gas evolved upon radiolytic decomposition per 100 ev. For phenolics, the G-value for gas evolution is given in Table 6.3 of Reference 1. For epoxy coatings, a value 10 times that for phenolics was used, based on the radiolysis of its constituent epichlorhydrin (Reference 2) and for conservatism.

**Gas Evolved = Total gas generated for 2 x 10⁸ rads dose. Not all gases evolved are hydrogen or methane. No experimental data or qualified procedures regarding hydrogen or methane generation from these coating systems under the subject conditions currently exist.

B/B-UFSAR

TABLE 6.1-5

CABLES IN CONTAINMENT

CABLE SIZE	OUTSIDE DIAMETER (in.)	WEIGHT (lbs)		VOLUME (ft ³)		INSULATION MATERIAL*	JACKET MATERIAL*
		UNCOVERED	COVERED	UNCOVERED	COVERED		
3-1/c 500 KCMIL	3.229	1754.5	5270.72	13.7	41.17	EPR	Hypalon
3/c 500 KCMIL	2.587	-	9912	-	51.1	EPR	Hypalon
1/c 500 KCMIL	1.072	1126.08	4760.1	3.83	8.71	EPR	Hypalon
4/c 4/0	2.038	284.24	953.04	1.54	5.16	EPR	Hypalon
3/c 4/0	1.848	179.85	542.82	1.02	3.09	EPR	Hypalon
1/c 4/0	0.73	-	36.8	-	0.13	EPR	Hypalon
4/c 4/0	1.608	-	380.7	-	2.28	EPR	Hypalon
3/c 1/0	1.458	362	1086	2.32	6.96	EPR	Hypalon
3/c #2	1.15	569.91	2928.2	3.39	17.46	EPR	Hypalon
2/c #2	1.008	1341.34	4024.69	11.09	33.29	EPR	Hypalon
1/c #2	0.447	27	81	0.11	0.33	EPR	Hypalon
3/c #6	0.953	355.35	2735.85	2.55	19.64	EPR	Hypalon
3/c #10	0.636	314.4	2080.8	2.31	15.3	EPR	Hypalon
3/c #14	0.512	-	12.92	-	0.11	EPR	Hypalon

B/B-UFSAR

TABLE 6.1-5 (Cont'd)

CABLE SIZE	OUTSIDE DIAMETER (in.)	WEIGHT (lbs)		VOLUME (ft ³)		INSULATION MATERIAL*	JACKET MATERIAL*
		UNCOVERED	COVERED	UNCOVERED	COVERED		
7/c #14	0.688	-	28.8	-	0.23	EPR	Hypalon
6/c (2 #2, 4 #6)	1.371	1635.4	4903.24	11.33	33.96	EPR	Hypalon
37/c #16	0.8	-	No. Infor.	-	0.55	EPR	Hypalon
19/c #16	0.5	-	No. Infor.	-	0.15	EPR	Hypalon
12/c #16	0.5	-	No. Infor.	-	0.07	EPR	Hypalon
12/c #14	0.945	1268.85	7264.95	11.24	64.34	EPR	Hypalon
14/c (2 #14, 12 #18)	0.6	-	No. Infor.	-	0.09	EPR	Hypalon
9/c #14	0.793	258	2143.98	2.06	17.1	EPR	Hypalon
7/c #14	0.688	536.32	2682.24	4.33	21.64	EPR	Hypalon
4/c #14	0.588	988.77	4537.21	8.1	37.2	EPR	Hypalon
2/c #14	0.484	357.3	2054.25	3.04	17.5	EPR	Hypalon
1/c #14	0.204	-	709.73	-	5.03	EPR	Hypalon
27/c #16	0.8	-	No. Infor.	-	0.19	EPDM	Hypalon
24/c (22 #20, 2 #12)	1.0	-	7209.55	-	80.74	EPDM	Hypalon
12 TW PR #16	1.08	-	963.11	-	11.65	EPDM	Hypalon

B/B-UFSAR

TABLE 6.1-5 (Cont'd)

CABLE SIZE	OUTSIDE DIAMETER (in.)	WEIGHT (lbs)		VOLUME (ft ³)		INSULATION MATERIAL*	JACKET MATERIAL*
		UNCOVERED	COVERED	UNCOVERED	COVERED		
8 TW PR #16	0.93	-	231.07	-	2.8	EPDM	Hypalon
8 TW PR #20	0.755	-	167.53	-	2.38	EPDM	Hypalon
5 TW PR #16	1.0	-	299.92	-	3.56	EPDM	Hypalon
4 TW PR #16	0.73	-	135.04	-	1.83	EPDM	Hypalon
4 TW PR #20	0.615	-	27.74	-	0.41	EPDM	Hypalon
3 TW PR #16	0.9	-	56.1	-	0.73	EPDM	Hypalon
4/c #2	0.5	-	32.94	-	0.5	EPDM	Hypalon
3/c #14	0.6	-	No. Infor.	-	0.62	EPDM	Hypalon
3/c #16	0.395	-	1868.66	-	19.16	EPDM	Hypalon
2 TW PR #16	0.62	-	1196.65	-	18.05	EPDM	Hypalon
1 TW PR #16	0.365	-	2554.6	-	28.13	EPDM	Hypalon
1 TW PR #20	0.325	-	374.21	-	4.69	EPDM	Hypalon
RG - 11/U TRIAX	0.4	-	814.37	-	8.46	EPDM	Hypalon
TOTAL		11,359.31	75,061.53	81.96	586.49		

*EPR - Ethylene - Propylene Rubber
 EPDM - Ethylene - Propylene Diene Monomer
 Hypalon - Chlorosulfonated Polyethylene

6.2 CONTAINMENT SYSTEMS

The containment systems include the containment heat removal systems, the containment isolation system, and the containment combustible gas control system. The containment and the containment systems function to prevent or control the release of radioactive fission products that might be released into the containment atmosphere following a postulated LOCA, secondary system pipe break, or fuel-handling accident.

6.2.1 Containment Functional Design

6.2.1.1 Containment Structure

The containment is a prestressed-concrete shell structure made up of a cylinder with a shallow dome roof and a flat foundation slab. The entire containment structure is lined on the inside with steel plate, which acts as a leak tight membrane. The containment completely encloses the entire pressurized water reactor, steam generators, reactor coolant loops, and portions of the auxiliary and engineered safeguard features (ESF) systems.

6.2.1.1.1 Design Bases

The containment systems are designed such that for all break sizes, up to and including the double-ended severance of a reactor coolant pipe or secondary system pipe, the containment peak pressure remains below the design pressure, with adequate margins, as presented in Tables 6.2-1 and 6.2-1a, for Unit 1 and 2, respectively. These margins are maintained by the containment system even assuming the worst single active failure affecting the operation of the emergency core cooling system, containment spray system, and the reactor containment fan coolers during the injection phase, and the worst active or passive single failure during the recirculation phase. For primary system breaks, loss of offsite power is assumed. For secondary system breaks, cases with and without the loss of offsite power have been evaluated. The offsite power available case is conservative for maximizing the releases to containment through forced convection of the reactor primary coolant due to reactor coolant pump operation. Assuming loss of offsite power is conservative for delaying safeguards actuation due to startup and loading of the emergency diesel generators. The Unit 1 and Unit 2 analyses considered cases with and without loss of offsite power separately in order to determine the limiting set of conditions.

The analyses presented in this section are based on assumptions which are conservative with respect to the design of the containment systems (i.e., minimum heat removal, maximum containment pressure). Subsection 6.2.1.2 presents the mass and energy releases and design evaluation of containment subcompartments. Subsections 6.2.1.3 and 6.2.1.4 present the mass and energy releases used in the design evaluation. Subsection 6.2.1.5 presents the results of the minimum containment pressure analysis used in the Large Break LOCA ECCS Analysis.

The results of analyses for the pressurizer spray line in the upper pressurizer cubicles and

the main steamline in the steam line pipe chases are included in Subsection 6.2.1.2.

6.2.1.1.2 Design Features

Containment design features include:

- a. A secondary shield wall constructed of 4-foot, 6-inch-thick reinforced concrete, extending from the base mat (elevation 377 feet 0 inch) to the operating floor (elevation 426 feet 0 inch). The shield wall encloses the reactor coolant pumps, reactor vessel and its primary shield wall, steam generators, the pressurizer up to elevation 426 feet 0 inch, and the refueling cavity. The secondary shield wall supports the operating floor, which together with the shield wall prevents the containment liner from being impacted by potential internal missiles and from the effects of pipe whip. Refer to Chapter 3.0 for a more detailed discussion.
- b. The Byron/Braidwood design does not use a pressure-suppression-type containment.

- c. Since the reactor containment fan coolers are utilized during normal operation with chilled water supplied to a non-safety-related cooling coil in each fan cooler, inadvertent changes to the accident mode will produce no significant effect upon containment internal pressure. The chilled water coils of the reactor containment fan coolers (RCFC) are designed to remove the containment heat in conjunction with essential service water coils during normal plant operation only and hence are non-safety-related. However, the essential service water coils and other components of the RCFC are safety-related as they would be required to operate following a LOCA for heat removal in the containment. For further description of the RCFC System operation and design requirements under post-LOCA conditions, refer to Subsections 6.2.2.2 and 6.2.2.3. For a description of RCFC system operation and design requirements under normal operation, refer to Subsection 9.4.8.1.

- d. Water may fill the refueling cavity until it empties into the reactor vessel cavity and floods the cavity up to base mat (elevation of 377 feet 0 inch). Other than this, there are no locations within the containment where water may be trapped and prevented from returning to the containment sump. Water that condenses within the reactor

containment fan cooler housing is drained to the containment base mat.

- e. The containment and subcompartment atmospheres are maintained during normal operation within prescribed pressure, temperature, and humidity limits by means of the containment chilled water systems which deliver 40°F water to the dehumidifying coils within each reactor containment fan cooler. Containment penetrations cooling is accomplished by means of supplying component cooling water to the penetrations that have cooling coils. Containment ventilation systems such as the CRDM booster fans and the CRDM cooling fans are used during normal operation and require no periodic testing to ensure functional capability.

6.2.1.1.3 Design Evaluation

The short-term pressure subcompartment analysis considers a loss of offsite power. Consideration of single active failures is of no consequence, since none of the safety equipment functions during the initial seconds of the postaccident transient. The maximum calculated differential pressure in the loop compartment is 20.27 psi resulting from a double-ended hot leg (DEHL) break in volume 3 (see Table 6.2-10 for listing of volumes). The maximum calculated differential pressure in the upper pressurizer cubicle is 10.24 psi resulting from a spray line double-ended break. The maximum calculated differential pressure in the steamline pipe chase is 13.43 psi resulting from a main steamline break in volume 26.

The containment subcompartment differential pressure analysis is described in detail in Subsection 6.2.1.2. The results of the pressure and temperature transient analysis of the containment for the loss-of-coolant accidents are shown in Figures 6.2-1 through 6.2-6 for Unit 1. Containment pressure and temperature curves are presented in Figures 6.2-7 through 6.2-12 for Unit 2. The cases examined in this analysis determine the effects of the full range of large reactor coolant break sizes up to and including a double-ended break. Cases illustrating the sensitivity to break location are also shown. All of these cases show that the containment pressure will remain below design pressure with margin. After the peak pressure is attained, the performance of the safeguards system reduces the containment pressure. At the end of the first day following the accident, the containment pressure has been reduced to a low value. The peak pressures and margins are shown in Tables 6.2-1 and 6.2-1a.

Additional containment analyses were performed for the purpose of evaluating ultimate heat sink capability (see Subsection 9.2.5). The containment analyses performed for the ultimate heat sink reconstitution differ from the containment integrity analyses described here in that the heat removal rates from the reactor containment fan coolers and the residual heat removal system were maximized to determine the limiting heat load on the ultimate heat sink.

|

The results of the pressure transient analysis of the containment for the secondary side breaks are presented in Tables 6.2-1 and 6.2-1a. The pressure and temperature curves for the most limiting steam breaks are presented in Figures 6.2-13 through 6.2-14e.

Calculation of containment pressure and temperature transients is accomplished by use of the digital computer code, COCO (Reference 1). The COCO code has been used and found acceptable to calculate containment pressure transients for the H.B. Robinson and Zion plants.

The analyses performed to evaluate the containment temperature and pressure response to a postulated main steamline break (MSLB) inside containment utilized the Westinghouse containment model developed for the IEEE-323-1971 Westinghouse Supplemental Equipment Qualification Program. These models and their justification (experimental and analytical) are detailed in Reference 2 and References 18 through 21.

The analysis of these containment models has been compared to the analyses for other Westinghouse plants where models were used which conform to those presented in CSB "Interim Evaluation Model for the Main Steam Line Break Inside Containment."

These comparisons indicate:

- a. The conservatism of the Westinghouse large steamline break containment model when used with dry steam blowdowns.
- b. The Westinghouse small steamline break containment model, using the convective heat flux heat transfer model, results in peak temperatures comparable to those calculated using the NRC Interim Proposed Model with 8% revaporization.

Details of the analytical model used to conservatively determine the maximum containment temperature and pressure for a spectrum of postulated main steam line breaks for various reactor power levels are provided below:

- a. Single failure in the safety grade systems required to mitigate the consequences of a spectrum of main steamline breaks inside containment were evaluated to determine the limiting set of conditions for Byron/Braidwood. One such failure is the failure of a main steam isolation valve to close. This

increases the steam pipe volume available for blowdown through the break. When all valves operate, only the volume between the steam generator and the first isolation valve adds to the blowdown. When the isolation valve fails to close, the volume between the break and the isolation valves in the other steamline becomes available as well as the volume of the safety and relief valve headers and other connecting lines.

Failure of the feedwater isolation valve to close was evaluated. This failure increases the volume of feedwater not isolated from the steam generator which would be available for blowdown. The volume increase is due to water between the feedwater isolation valve and the feedwater regulating valve including all headers and connecting lines.

While the steamline and feed water isolation valves are closing, the flow is considered as unrestricted until the time of complete closure.

Auxiliary feedwater flow that continues after isolation of the steam and feedlines was included in the analysis. Excessive blowdown of auxiliary feedwater through the depressurized steam generator is prohibited by the flow limiting orifices installed in each auxiliary feedwater supply line. Within 30 minutes, auxiliary feedwater flow to the depressurized steam generator is isolated manually by the operator from the control room. Auxiliary feedwater flow to the intact steam generators is assumed to continue.

A blowdown increase due to a failure of the main feedwater pump trip was included in the analysis.

Single failure of the containment cooling systems with reduction of heat removal capability was included. These were by a train failure or by a diesel failure after a loss of offsite power.

All NSSS equipment to be relied on for the transients are safety grade.

- b. The design temperature for the liner is 280°F. The design temperature of the internal containment structure is 280°F.

The peak containment temperature for a primary side break is 264.24°F for Unit 1 and 257.40°F for Unit 2. The peak containment temperature for secondary side breaks is 329°F for Unit 1 and 323°F for Unit 2. Refer to Tables 6.2-1 and 6.2-1a.

The justification for the design temperatures, provided in Table 6.2-66, selected for the liner and internal containment structures is that they are conservative when the duration of the peak temperature for the secondary side break, the temperature lag between the containment atmosphere and the passive heat sinks such as the containment liner and

internal structures, and the resistance to heat transfer provided by the materials used, are considered.

The design temperatures defined for the qualification of Westinghouse PWR-SD supplied safety-related instrumentation inside containment are provided in Supplement 1 (Rev. 1, November, 1978) to WCAP-8587 "Methodology for Qualifying Westinghouse PWR-SD Supplied NSSS Safety Related Electrical Equipment."

- c. The piping volumes from the plant layout between the affected steam generator and the various steamline isolation valves and feedwater isolation valves and control valves are the following. The maximum volume between the affected steam generator and: (1) the main steam isolation valve is 766 ft³ for Unit 1 and 749 ft³ for Unit 2, (2) the main steam isolation valves for the intact steam generators is 11,575 ft³ for Unit 1 and 11,358 ft³ for Unit 2, (3) the main feedwater isolation valve is 222 ft³ for Unit 1 and 175 ft³ for Unit 2, and (4) the main feedwater control valve is 702 ft³ for Unit 1 and 655 ft³ for Unit 2. The assumed analysis values for the Unit 1 volumes conservatively bound the as-built values shown in Figures 6.2-38 and 6.2-39. The volumes for Unit 2 are shown in Figures 6.2-38 and 6.2-40.

The main feedwater isolation valves have a 5-second maximum closure time. The main steam and feedwater preheater bypass valves have a 6-second maximum closure time. The main feedwater control valves are discussed in Subsection 6.2.1.4.3. Automatic closure of auxiliary feedwater isolation valves is not a requirement.

Blowdown from the broken steamline is assumed to be saturated steam.

Transient phenomena within the reactor coolant system affect containment conditions by means of convective mass and energy transport through the pipe break.

For analytical rigor and convenience, the containment air-steam-water mixture is separated into two systems. The first system consists of the air-steam phase; the second is the water phase. Sufficient relationships to describe the transient are provided by the equations of conservation of mass and energy as applied to each system, together with appropriate boundary conditions. As thermodynamic equations of state and conditions may vary during the transient, the equations have been derived for all possible cases of superheated or saturated steam and

subcooled or saturated water. Switching between states is handled automatically by the code. The following are the major assumptions made in the analysis:

- a. Discharge mass and energy flow rates through the reactor coolant system break are established from the analysis in Subsection 6.2.1.3.
- b. For the steam break analysis and the blowdown portion of the LOCA analysis, the discharge flow separates into steam and water phases at the break point. The saturated water phase is at the total containment pressure, while the steam phase is at the partial pressure of the steam in the containment. For the post-blowdown portion of the LOCA analysis, steam and water releases are input separately.
- c. Homogeneous mixing is assumed. The steam-air mixture and the water phase each have uniform properties. More specifically, thermal equilibrium between the air and steam is assumed. This does not imply thermal equilibrium between the steam-air mixture and water phase.
- d. Air is taken as an ideal gas, while compressed water and steam tables are employed for water and steam thermodynamic properties.
- e. For large steamline breaks the saturation temperature at the partial pressure of the steam is used for heat transfer.
- f. For small steamline breaks the model described in Section 2 of Reference 2 was utilized with plant-specific data and stagnant Tagami heat transfer.

Subsections 6.2.1.3 and 6.2.1.4 present the mass and energy releases used for the analysis.

Initial Conditions

An analysis of containment response to the break of the reactor coolant system must start with knowledge of the initial conditions in the containment. The pressure, temperature, and relative humidity of the containment atmosphere prior to the postulated accident are specified in the analysis. |

Also, values for the temperature of the service water and refueling water storage tank solution are assumed, along with the initial water inventory of the refueling water storage tank. All of these values are chosen conservatively, as shown in Tables 6.2-2 and 6.2-3.

In each of the transients, the safeguards systems shown in Tables 6.2-2 and 6.2-3 are assumed to operate at the times indicated in Tables 6.2-6 through 6.2-9c.

Heat Removal

The significant heat removal source during the early portion of the transient is structural heat removal. Provision is made in the containment pressure transient analysis for heat transfer through, and heat storage in, both interior and exterior walls. Every wall is divided into a large number of nodes. For each node, a conservation of energy equation expressed in finite-difference form accounts for transient conduction into and out of the node and temperature rise of the node. Tables 6.2-4 and 6.2-5 are summaries of the containment structural heat sinks used in the analysis. To generate the values in Table 6.2-4, a complete and detailed list of surface areas and thicknesses of structures and equipment in the containment was compiled. An uncertainty from 0 to -50% was assigned to each of the nominal surface areas in Table 6.2-4a. When the surface areas of several items were combined into one table entry, the appropriate uncertainty for each individual area was applied before the combined area was calculated. All areas were reduced to the minimum value in the uncertainty range specified. Thicknesses were reduced to give conservatively small total volume when several items of varying thickness were combined into one table entry. This procedure resulted in a conservatively small estimate of the available heat sinks.

The heat transfer coefficient to the containment structure is calculated by the code based primarily on the work of Tagami (Reference 3). From this work, it was determined that the value of the heat transfer coefficient increases parabolically to peak value at the end of blowdown for LOCA and increases parabolically to peak at the time of steamline isolation. The value then decreases exponentially to a stagnant heat transfer coefficient which is a function of steam to air weight ratio.

Tagami presents a plot of the maximum value of h as a function of "coolant energy transfer speed," defined as follows:

$$\frac{\text{total coolant energy transferred into containment}}{(\text{containment volume}) (\text{time interval to peak pressure})}$$

From this the maximum h of steel is calculated:

$$h_{\max} = \frac{(E^{0.60})}{t_{pv}} \quad (6.2-1)$$

where:

- h_{\max} = maximum value of h (Btu/hr ft²°F),
- t_p = time from start of accident to end of blowdown for LOCA and steamline isolation for secondary breaks (sec),
- V = containment volume (ft³), and
- E = coolant energy discharge (Btu).

The parabolic increase to the peak value is given by:

$$h_s = h_{\max} \sqrt{\frac{t}{t_p}}, \text{ for } 0 \leq t \leq t_p \quad (6.2-2)$$

where:

- h_s = heat transfer coefficient for steel (Btu/hr ft²°F), and
- t_p = time from start of accident (sec).

For concrete, the heat transfer coefficient is taken as 40% of the value calculated for steel.

The exponential decrease of the heat transfer coefficient is given by:

$$h_s = h_{\text{stag}} + (h_{\max} - h_{\text{stag}}) e^{-0.05(t-t_p)}, \text{ for } t < t_p$$

where:

- h_{stag} = $2 + 50X$, for $0 \leq X \leq 1.4$,
- h_{stag} = h for stagnant conditions (Btu/hr ft²°F), and
- X = steam-to-air weight ratio in containment.

The heat transfer coefficients for the most limiting steamline breaks are presented in Figures 6.2-16 through 6.2-16c.

For a large break the safety features are quickly brought into operation. Because of the brief period of time required to depressurize the reactor coolant system, the safeguards are not a major influence on the blowdown peak pressure; however, they reduce the containment pressure after the blowdown and maintain a low long-term pressure. Also, although the containment

structure is not as effective a heat sink as during the reactor coolant system blowdown, it still contributes significantly as a form of heat removal during the long-term cooling period.

During the injection phase of postaccident operation, the emergency core cooling system pumps water from the refueling water storage tank into the reactor vessel. Since this water enters the vessel at refueling water storage tank temperature, which is less than the temperature of the water in the vessel, it can absorb heat from the core until saturation temperature is reached. During the recirculation phase of operation, water is taken from the containment sump and cooled in the residual heat removal heat exchanger. The cooled water is then pumped back to the reactor vessel to absorb more decay heat. The heat is removed from the residual heat removal heat exchanger by component cooling water.

Another containment heat removal system is the containment spray. During the injection phase of operation, the containment spray pumps draw water from the refueling water storage tank and sprays it into the containment through nozzles mounted high above the operating deck. As the spray droplets fall, they absorb heat from the containment atmosphere. Since the water comes from the refueling water storage tank, the entire heat capacity of the spray from the refueling water storage tank temperature to the temperature of the containment atmosphere is available for energy absorption. During the recirculation phase of postaccident operation, water is drawn from the sump and sprayed into the containment atmosphere.

When a spray drop enters the hot, saturated, steam-air containment environment following a loss-of-coolant accident, the vapor pressure of the water at its surface is much less than the partial pressure of the steam in the atmosphere. Hence, there will be diffusion of steam to the drop surface and condensation on the drop. This mass flow will carry energy to the drop. Simultaneously, the temperature difference between the atmosphere and the drop will cause the drop temperature and vapor pressure to rise. The vapor pressure of the drop will eventually become equal to the partial pressure of the steam and the condensation will cease. The temperature of the drop will essentially equal the temperature of the steam-air mixture.

The equations describing the temperature rise of a falling drop are as follows:

$$\frac{d}{dt} (Mu) = mh_g + q \quad (6.2-3)$$

$$\frac{d}{dt} (M) = m \quad (6.2-4)$$

where:

$$q = h_c A (T_s - T), \text{ and}$$

$$m = k_g A (P_s - P_v).$$

The coefficients of heat transfer (h_c) and mass transfer (k_g) are calculated from the Nusselt number for heat transfer, \underline{Nu} , and the Nusselt number for mass transfer, \underline{Nu}' .

Both \underline{Nu} and \underline{Nu}' may be calculated from the equations of Ranz and Marshall (Reference 4).

$$\underline{Nu} = 2 + 0.6 (\text{Re})^{1/2} (\text{Pr})^{1/3} \quad (6.2-5)$$

$$\underline{Nu}' = 2 + 0.6 (\text{Re})^{1/2} (\text{Sc})^{1/3}$$

Thus, Equations 6.2-3 and 6.2-4 can be integrated numerically to find the internal energy and mass of the drop as a function of time as it falls through the atmosphere. Analysis shows that the temperature of the (mass) mean drop produced by the spray nozzles rises to a value within 99% of the bulk containment temperature in less than 2 seconds.

Drops of this size will reach temperature equilibrium with the steam-air containment atmosphere after falling through less than half the available spray fall height.

Detailed calculations of the heatup of spray drops in postaccident containment atmospheres by Parsly (Reference 5) show that drops of all sizes encountered in the containment spray reach equilibrium in a fraction of their residence time in a typical pressurized water reactor containment.

These results confirm the assumption that the containment spray will be 100% effective in removing heat from the atmosphere.

Nomenclature

A	= area,
h_c	= coefficient of heat transfer,
k_g	= coefficient of mass transfer,
h_g	= steam enthalpy,
M	= droplet mass,
m	= diffusion rate,
Nu	= Nusselt number for heat transfer,
Nu'	= Nusselt number for mass transfer,

P_s	= steam partial pressure,
P_v	= droplet vapor pressure,
Pr	= Prandtl number,
q	= heat flow rate,
Re	= Reynolds number,
Sc	= Schmidt number,
T_s	= droplet temperature,
T	= steam temperature,
t	= time, and
u	= internal energy.

The reactor containment fan coolers are a final means of heat removal. The main aspect of a fan cooler from the heat removal standpoint are the fan and the banks of cooling coils. The fans draw the dense atmosphere through banks of finned cooling coils and mix the cooled steam/air mixture with the rest of the containment atmosphere. The coils are kept at a low temperature by a constant flow of cooling water. Since this system does not use water from the refueling water storage tank, the mode of operation remains the same both before and after the spray system and emergency core cooling system change to the recirculation mode. The fan cooler performance as a function of saturation temperature is given in Figure 6.2-25. The data in Figure 6.2-25 conservatively minimize the fan cooler heat removal rate for use in MSLB and LOCA containment response analyses. In addition to the fan cooler design data in Table 6.2-56, conservative assumptions used to develop the fan cooler performance curve in Figure 6.2-25 include:

Operation in accident mode

Service water inlet temperature	100°F Byron (Note 1) 104°F (Note 2), Braidwood
Inlet air flow rate	65,000 ACFM
Tube fouling factor	0.0015 hr-ft ² -°F/Btu
Service water flow rate	2660 gpm
Tube plugging	10%

Note 1 - The Braidwood RCFC performance curve (104°F service water inlet temperature) was conservatively used in the Byron containment response analyses.

Note 2 - The maximum initial UHS temperature is 102°F. The RCFC performance curve reflects the UHS temperature post LOCA (See Figure 9.2-9).

Inadvertent Spray Actuation

In the event of inadvertent spray, the containment would depressurize until the temperature of the air was approximately the temperature of the spray. A calculation was performed to calculate the maximum outside to inside pressure differential. The following initial conditions were assumed:

- a. The containment is initially at 120°F, which maximizes the temperature differential between the containment atmosphere and the spray, which is at a temperature of 35°F.
- b. The containment is at 14.7 psia.
- c. The relative humidity is at a maximum value of 100%.

As the air temperature is reduced, the partial pressure of the air decreases from 13.007 to 11.1 psia. The steam partial pressure decreases from 1.6927 to 0.09991 psia as the spray cools the atmosphere. Thus a containment pressure of 11.2 psia is

produced, causing a differential pressure of 3.5 psi across the containment shell.

Accident Chronology

For the double-ended pump suction and double-ended hot leg loss-of-coolant accidents, the major events and their times of occurrence are shown in Tables 6.2-6 through 6.2-8. Tables 6.2-9 through 6.2-9c present the accident chronology for the limiting steamline breaks. In the event of a LOCA or main steamline break in conjunction with loss of offsite power, the diesel generators will receive a start signal and energize the emergency buses within 13 seconds. An additional 2 seconds is required for switching and activation of the sequencer logic before the major loads begin to sequence onto the diesel generators. Therefore, the containment spray pumps are available at 30 seconds or if not required at 30 seconds, the pumps will be available after 55 seconds. As noted in Table 8.3-5, the RCFCs are loaded on the emergency buses 20 seconds following initiation of the safety injection signal.

The RCFCs will operate at full power 5 seconds after loading onto emergency power. The containment spray (CS) pumps operate at full power 2.1 seconds after startup. The CS containment isolation valves require 10 seconds to open. The valves are immediately loaded onto the ESF buses. The containment spray system is kept full at least to the 407 foot elevation (isolation valve) by the RWST. It will require less than 51.1 seconds to fill the spray system and achieve full flow. This fill time conservatively considers the lowest CS Pump capacity (A Train) and the largest CS header volume (B Train).

For LOCA and MSLB containment analysis the assumptions for containment spray (CS) and reactor containment fan cooler (RCFC) delay times bound the times described above.

The RCFC delay and startup sequence times assumed for the loss of offsite power cases are given below. This sequence is applicable for cases in which the RCFCs receive a start signal within 38 seconds of the initiation of the event. Receipt of the actuation signal within 38 seconds guarantees that the RCFCs will start and be at full speed by the time that the essential service water (SX) pumps have loaded onto the emergency diesel generators. Therefore, 65 seconds is the assumed actuation time (not a delay) for these cases.

Electronics Delay	2 seconds
Emergency Diesel Generator Start	15 seconds
SX Pump Loaded on Emergency Diesel Generators	25 seconds
SX Pumps at Full Power and Flow	<u>23</u> seconds
TOTAL ACTUATION TIME	65 seconds *

* For the Unit 2 MSLB analysis, the total actuation time is assumed to be 66.3 seconds, and the above sequence is applicable to cases in which the RCFCs receive a start signal within 38.8 seconds of the initiation of the event.

B/B-UFSAR

The RCFC delay and startup sequence times assumed for the offsite power available cases or for cases in which the RCFC actuation signal is received after 38 seconds are given below. This sequence is a delay time (not an actuation time) after the RCFC actuation signal is received. For the offsite power available cases, the RCFC delay may be considerably shorter than the loss of offsite power cases because the SX pumps will already be running at high speed.

Electronics Delay	2 seconds
RCFC Start Delay (Allows Coastdown to Low Speed)	20 seconds
RCFCs at Full Power	5 seconds
	<hr/>
TOTAL DELAY TIME	27 seconds *

* For the Unit 2 MSLB analysis, the total delay time assumed is 27.5 seconds, and the above sequence is applicable to cases in which the RCFCs receive a start signal after 38.8 seconds of the initiation of the event.

The CS delay and startup sequence times assumed for the loss of offsite power cases are given below. This CS actuation sequence allows for CS pump loading onto the emergency diesel generators 40 seconds after sequencing starts (consistent with the later time given in Table 8.3-5). In addition, this sequence allows for a 20-second stroke time for the CS valves and assumes that the CS valves must be fully open in order for the CS pump to load onto the emergency diesel generators. Since the CS valves will not begin to open until the CS actuation setpoint has been reached, the setpoint must be reached 20 seconds before the CS pumps load onto the emergency diesel generator. Therefore, this sequence is applicable for cases in which the CS start signal is received within 35 seconds of the initiation of the event. If the CS actuation setpoint is reached within 35 seconds, 88.1 seconds is the assumed actuation time (not a delay) for these cases.

Electronics Delay	2 seconds
Emergency Diesel Generator Start	15 seconds
CS Pumps Loaded on Emergency Diesel Generators	40 seconds
CS Pumps at Full Flow	2.1 seconds
Time to Fill Header and Attain Full Flow	51.1 seconds
	<hr/>
TOTAL ACTUATION TIME	110.2 seconds *

* For the Unit 2 MSLB analysis, the total actuation time is assumed to be 112.0 seconds, and the above sequence is applicable to cases in which the CS actuation setpoint is reached within 35.7 seconds of the initiation of the event.

B/B-UFSAR

The CS delay and startup sequence assumed for the offsite power available cases in which the CS actuation signal is received after 35 seconds is given below. This sequence is a delay time (not an actuation time) after the CS signal is received. For the offsite power available cases, the CS delay may be shorter than the loss of offsite power cases because the CS pumps will already have a power supply and will not have to wait to load onto the emergency diesel generator. For the cases in which the actuation setpoint is reached after 35 seconds, there will also be no delay since they will load onto the emergency diesel generator as soon as the CS valves are open. In these cases, there will be no emergency diesel generator loading delay.

Electronics Delay	2 seconds
CS Valves Stroke Time	20 seconds
CS Pumps at Full Flow	2.1 seconds
Time to Fill Header and Attain Full Flow	51.1 seconds
	<hr/>
TOTAL DELAY TIME	75.2 seconds *

* For the Unit 2 MSLB analysis, the total delay time assumed is 76.3 seconds, and the above sequence is applicable to cases in which the RCFCs receive a start signal after 35.7 seconds of the initiation of the event.

6.2.1.2 Containment Subcompartments

6.2.1.2.1 Design Basis

Based on the regulatory approval of (1) the main coolant loop piping leak-before-break analysis (Reference 41) performed by Westinghouse (Westinghouse Report WCAP-14559), (2) the accumulator line piping and reactor coolant loop bypass piping leak-before-break analysis (Reference 42) performed by Sargent & Lundy (SL-4518), and (3) the scope outlined in General Design Criterion 4, the containment subcompartments need not be designed for dynamic pressurization loads due to postulated primary coolant loop piping breaks (Reference 43). The subcompartments are not necessary to containment function, and therefore, dynamic or non-static pressurization need not be considered.

The reactor cavity and RPV nozzle inspection cavity, therefore, need not consider the pressurization loads due to the primary coolant loop cold leg nozzle breaks. In particular, the inspection cavity shield doors no longer are required to serve as a mechanism to vent the cavity into the main containment.

The loop compartment design bases loads may no longer result from the primary coolant loop breaks, although the evaluation for these loads are retained in the UFSAR. These breaks are controlling when compared to other high energy line breaks which occur in these compartments.

Loop Compartment, Upper Pressurizer Cubicles, and Steamline
Pipe Chase

Reference 6 provides the basis for break locations, types, and areas. The design-basis break for the subcompartments is a circumferential, double-ended guillotine break of high-pressure system pipe which yields the maximum mass and energy release rates. Since the circumferential double-ended guillotine break of a system pipe is the design basis, no credit is taken for limiting break areas due to pipe restraints.

The subcompartment nodal volumes are presented in Table 6.2-10 and the vent areas in Table 6.2-11.

6.2.1.2.2 Deleted

6.2.1.2.3 Design Evaluation

6.2.1.2.3.1 Analytical Models

The analytical model used to calculate the mass and energy releases is fully described in Reference 7. The TMD code for subcompartment pressure transients is fully described in Reference 8. The TMD code with unaugmented critical flow and

"Y" compressibility factor was used to calculate the subcompartment pressure transients.

6.2.1.2.3.2 Break Type and Size

The analysis discussed in this section applies to Unit 2. The Unit 1 steam generators are bounded by the analysis for Unit 2 because of the difference in blowdown area of the integral flow restrictors.

A double-ended guillotine (DEG) break is more severe for mass and energy release. This break models a complete severance of two ends of a broken pipe with an available break area corresponding to twice the pipe cross-sectional area. Only the main steamline break considers the use of a break limiter. The main steamline DEG break or double-ended rupture (DER) is assumed to occur downstream of the flow limiter (1.1 ft² for Unit 1 and 1.4 ft² for Unit 2) in the steamline pipe chase such that flow from the faulted steam generator is limited below the pipe cross-sectional area. The integral flow restrictors of the steam generators of the intact loops will also eventually limit the backflow through the main steam header.

6.2.1.2.3.3 Model Description

The containment subcompartment nodalization diagram is presented in Figure 6.2-18. Plan and section drawings are included in Drawings M-5 through M-18. A specific nodalization sensitivity study was not performed. Various models (nodalization schemes) were set up to determine the minimum number of volume nodes required to conservatively predict the maximum pressure load. The nodalization for this analysis was based on natural geometric boundaries and constraints so that the largest pressure gradients occur across the control volume boundaries.

To further clarify the subcompartment nodal model of Subsection 6.2.1.2.3.3, Table 6.2-67 lists and briefly describes each nodal volume with respect to its physical location in the containment. Nodal numbers 1 through 6 are the subcompartments located inside the crane wall and below the operating deck and divided at the points of least flow area created by the four steam generators, the refueling canal, and the concrete structures opposite the refueling canal. Nodal number 7 consists of all the volume above the operating deck, plus the net volume of the refueling canal and the upper reactor cavity. Nodal numbers 8 through 15 are the subcompartments located outside the crane wall, below the operating deck, and above the intermediate floor. The areas were divided at the points of maximum flow area obstruction (i.e., maximum flow restriction). Nodal numbers 16 through 23 are the subcompartments located outside the crane wall, and below the intermediate floor. These nodes were divided in a similar manner to those of nodes 8 through 14.

Nodal number 28 models the pressurizer compartment. The only high energy line in this cavity is the 6-inch spray line. Since breaks are normally postulated at points of stress concentration, it is therefore postulated that the only point a break might occur on the spray line would be at the elbow, which is near the top of the pressurizer. If this line were to break at the elbow, above the separative floor in the pressurizer cavity, the flashing fluid and subsequent local pressure transient would be vented out the top of the cavity which is open and only a few feet above the elbow of the line. This venting would relieve the pressure immediately and result in a minimum, if any, load on the pressurizer.

In general, the flow constraints occurred at the points of free volume subdivision, between such compartments which resulted in

the least flow area due to maximum flow area obstruction. Figure 6.2-18 has been updated to show all the nodes and flow paths.

The loop compartments, upper pressurizer cubicle, and steamline pipe chase were analyzed using the above mentioned model. The subcompartment volume description and initial conditions are listed in Table 6.2-10. The subcompartment flowpath descriptive information is presented in Table 6.2-11.

Junction loss coefficients were calculated using Idel'chik's Handbook, Reference 17. The employed method of determining the loss coefficients is best described by sample calculations.

- a. Loss coefficients due to turning were calculated based on the data presented in Idel'chik (Section 6) and, in particular, Diagram 6.2. Thus, for example, the loss coefficient for the junction 1 extending from the center of the control volume 1 to the center of control volume 2 is calculated to be 0.35 based on the flow area 0.83 ft^2 . For this calculation it was conservatively assumed that the mean height of roughness peaks of the junction surfaces was 1.0 mm, and the Reynolds number (Re) exceeded 2×10^5 during the most significant time period of the pressure transients. These two assumptions are made throughout the model.

- b. Loss coefficient calculation for junction 31 connecting the control volume 1 with the control volume of the main containment illustrates calculations of friction losses as well as calculations of losses due to a "discharge through thick edged orifice," and the method of combining individual losses along a junction. Using Idel'chik, Diagram 2.4, the friction loss coefficient was calculated at 0.06 based on the flow area 2.82 ft². Losses due to the discharge through the 1 3/4 inch gap at the top of the separation wall were calculated using data in the Idel'chik, Diagram 11-28. Calculations yielded loss coefficient of 2.04 based on the minimum junction flow area 1.05 ft². The total (combined) junction loss coefficient was then calculated, using relationship:

$$\frac{K_{tot}}{A_{min}^2} = \Sigma \frac{K_i}{A_1^2}$$

to be 2.05, based on the minimum junction flow area 1.05 ft².

- c. Junction 75 connecting control volumes 31 and 7, is an example when (due to a lack of an applicable configuration in Idel'chik) loss coefficient was estimated for two configurations reported and the more conservative valve adopted. First, the configuration was approximated as a "thick walled orifice" (Idel'chik, Diagram 4-18) and loss coefficient of 1.80 calculated based on the junction minimum flow area of 4.0 ft² (gap between the penetration wall and the bare pipe after the pipe insulation has been blown off). Second, the junction was approximated with a "free discharge from an annular-radial diffuser" (Idel'chik, Section 11-9) and to the resulting loss coefficient (0.8) an entrance loss of 0.5 was added. Thus, in this case, the total junction loss coefficient was 1.3 based on the junction minimum flow area.

Control volume and junction characteristics as well as the initial conditions are given in Tables 6.2-11b and 6.2-11c.

Selected model options include such as 100% entrainment and Moody's critical flow model with flow coefficient of 0.6.

6.2.1.2.3.4 Pressure Responses

The tabulation of maximum pressure differential is presented in Table 6.2-12.

Loop Compartments

Two postulated breaks, a double-ended cold leg (DECL) guillotine break and a double-ended hot leg (DEHL) guillotine break, maximize mass and energy release to the loop compartment. A DEHL in volume 3 yielded the maximum pressure differential (20.27 psi) for the loop compartment. The mass and energy release rates for the DEHL guillotine break are presented in Table 6.2-13. The break compartment (volume 3) and the upper containment (volume 9) pressure transients are graphed in Figure 6.2-19. Results of the maximum pressure differentials for a DEHL break in each loop compartment volume are tabulated in Table 6.2-12. A DECL break yielded a maximum pressure differential when the break occurred in volume 3. The mass and energy release rates for DECL guillotine break are presented in Table 6.2-14. The break compartment (volume 3) and upper containment (volume 7) pressure transients are graphed in Figure 6.2-20. Results of maximum pressure differentials for DECL break in each loop compartment volume are tabulated in Table 6.2-12.

Upper Pressurizer Cubicles

A double-ended spray line break is most severe for the vapor space in the upper pressurizer cubicle. The mass and energy release rates are presented in Table 6.2-15. The break compartments (volume 28) and upper containment (volume 7) pressure transients are graphed in Figure 6.2-21. The maximum pressure differentials across the cubicle walls are tabulated in Table 6.2-12. The data presented in Tables 6.2-12, 6.2-15, and Figure 6.2-21 for the pressurizer spray line break apply to both Unit 1 and Unit 2.

Steamline Pipe Chase

The steamline double-ended break with flow limiters (see Subsection 6.2.1.2.3.2) provides maximum blowdown mass and energy releases to the steamline pipe chases. The steamline mass and energy releases are presented in Table 6.2-16. Breaks in volumes 25 and 26 are considered. Break compartments 25 and 26 and upper containment (volume 7) pressure transients are graphed in Figures 6.2-22 and 6.2-23. The maximum pressure differentials are presented in Table 6.2-12.

The following assumptions/methodology were used in generating the short-term mass and energy releases found in Table 6.2-16 for the steamline pipe chase analysis:

- a. Length of pipe was identified by the Architect-Engineer within the steam generator enclosure inside containment.
- b. A full double-ended break was postulated in the steam piping in this area.

- c. Moody critical mass velocities were assumed based on reservoir quality and pressure.
 - 1. Steam generator pressure was assumed to be no-load value.
 - 2. Both dry steam and entrainment are considered consistent with D series steam generator data.
 - 3. Break flows were calculated based on steam piping cross-sectional areas. For example, initial steam flows will be choked by break area (approximately 5.0 ft²) and later by the steam generator-integral flow restrictors. The analysis discussed in this section applies to Unit 2. The Unit 1 steam generators are bounded by the analysis for Unit 2 because of the difference in blowdown area of the integral flow restrictors.
- d. Both forward and reverse flows were considered based on appropriate piping volumes.
- e. Time intervals were calculated based on the above information contained in items c and d. Times were minimized and maximized for conservatism by varying the break location inside the enclosure.

All of the assumptions listed above yield bounding mass and energy releases for the steamline pipe chase analysis.

6.2.1.3 Mass and Energy Release Analyses For Postulated Loss-of-Coolant Accidents

The uncontrolled release of pressurized high temperature reactor coolant, termed a Loss-of-Coolant Accident (LOCA), will result in release of steam and water into the containment. This, in turn will result in increases in the global containment pressure and temperature. Therefore, a postulated LOCA was considered for Byron Unit 1&2 and Braidwood Unit 1&2.

The long-term LOCA mass and energy releases are analyzed to approximately 1E+06 seconds and are utilized as input to the containment integrity analysis, which demonstrates the acceptability of the containment safeguards systems to mitigate the consequences of a hypothetical large break LOCA. The containment safeguards systems must be capable of limiting the peak containment pressure to less than the design pressure and to limit the temperature excursion to less than the Environmental Qualification (EQ) acceptance limits. The mass and energy releases were generated using the March 1979 model, described in Reference 37. The NRC review and approval letter is included with Reference 37.

6.2.1.3.1 Long Term LOCA Mass and Energy Releases

The mass and energy release rates described in this section form the basis for the containment pressure calculations presented in Section 6.2.1.1.3. Discussed in this section are the long-term LOCA mass and energy releases for the hypothetical double-ended pump suction (DEPS) rupture and double-ended hot leg (DEHL) rupture break cases for Byron/Braidwood Unit 1 with the BWI steam generator and Byron/Braidwood Unit 2 with the Westinghouse model D5 steam generator.

Input Parameters and Assumptions

The mass and energy release analysis is sensitive to the assumed characteristics of various plant systems, in addition to other key modeling assumptions. Where appropriate, bounding inputs are utilized and instrumentation uncertainties are included. For example, the RCS operating temperatures are chosen to bound the highest average coolant temperature range of all operating cases, and a temperature uncertainty allowance of (9.1°F) is then added. Nominal parameters are used in certain instances. For example, the reactor coolant system (RCS) pressure in this analysis is based on a nominal value of 2250 psia plus an uncertainty allowance (+43 psi). All input parameters are chosen consistent with accepted analysis methodology.

Some of the most-critical items are the RCS initial conditions, core decay heat, safety injection flow, and primary and secondary metal mass and steam generator heat release modeling. Specific assumptions concerning each of these items are next discussed. Table 6.2-17, 6.2-18, and 6.2-18a present key data assumed in the analysis.

The core rated power of 3658.3 Mwt was used in the analysis. As previously noted, the use of RCS operating temperatures to bound the highest average coolant temperature range were used as bounding analysis conditions. The use of higher temperatures is conservative because the initial fluid energy is based on coolant temperatures that are at the maximum levels attained in steady state operation. Additionally, an allowance to account for instrument error and deadband is reflected in the initial RCS temperatures. As previously discussed, the initial reactor coolant system (RCS) pressure in this analysis is based on a nominal value of 2250 psia an allowance which accounts for the measurement uncertainty on pressurizer pressure. The selection of 2250 psia as the limiting pressure is considered to affect the blowdown phase results only, since this represents the initial pressure of the RCS. The RCS rapidly depressurizes from this value until the point at which it equilibrates with containment pressure.

The rate at which the RCS blows down is initially more severe at the higher RCS pressure. Additionally, the RCS has a higher fluid density at the higher pressure (assuming a constant temperature) and subsequently has a higher RCS mass available for releases. Thus, 2250 psia plus uncertainty was selected for the initial pressure as the limiting case for the long-term mass and energy release calculations.

The selection of the fuel design features for the long-term mass and energy release calculation is based on the need to conservatively maximize the energy stored in the fuel at the beginning of the postulated accident (i.e., to maximize the core stored energy). Core stored energy is based on the time in life for maximum fuel densification. The assumptions used to calculate the fuel temperatures for the core stored energy calculation account for appropriate uncertainties associated with the models in the PAD 4.0 code (e.g., calibration of the thermal model, pellet densification model, cladding creep model, etc.). In addition, the fuel temperatures for the core stored energy calculation account for appropriate uncertainties associated with manufacturing tolerances (e.g., pellet as-built density). The total uncertainty for the fuel temperature calculation is a statistical combination of these effects and is dependent upon fuel type, power level, and burnup.

Margin in RCS volume of 3% (which is composed of 1.6% allowance for thermal expansion and 1.4% for uncertainty) is modeled.

B/B-UFSAR

A uniform steam generator (SG) tube plugging level of 0% is modeled. This assumption maximizes the reactor coolant volume and fluid release by virtue of consideration of the RCS fluid in all SG tubes. During the post-blowdown period the steam generators are active heat sources since significant energy remains in the secondary metal and secondary mass that has the potential to be transferred to the primary side. The 0% tube plugging assumption maximizes heat transfer area and therefore the transfer of secondary heat across the SG tubes.

Additionally, this assumption reduces the reactor coolant loop resistance, which reduces the ΔP upstream of the break for the pump suction breaks and increases break flow. Thus, the analysis bounds any level of steam generator tube plugging that may occur in the future.

Regarding safety injection flow, the mass and energy release calculation considered configurations/failures to conservatively bound respective alignments. The cases include: (a) Minimum Safeguards Case (1 CV, 1 SI, and 1 RH Pumps); and (b) Maximum Safeguards, (2 CV, 2 SI, and 2 RH Pumps).

The following assumptions were employed to ensure that the mass and energy releases are conservatively calculated, thereby maximizing energy release to containment.

- a. Maximum expected operating temperature of the reactor coolant system (100% full power conditions)
- b. Allowance for RCS temperature uncertainty (+9.1°F)
- c. Margin in RCS volume of 3% (which is composed of 1.6% allowance for thermal expansion, and 1.4% for uncertainty)
- d. Core rated power of 3658.3 MWt which includes calorimetric error.
- e. Conservative heat transfer coefficient (i.e., steam generator primary/secondary heat transfer and reactor coolant system metal heat transfer)
- f. Allowance in core stored energy that is based on a statistical combination of effects including fuel type, power level, manufacturing tolerances, densification and burnup.
- g. An allowance for RCS initial pressure uncertainty (+43 psi)
- h. A maximum containment backpressure equal to the Pa Technical Specifications value (42.8 psig for Unit 1 and 38.4 psig for Unit 2).
- i. Minimum RCS loop flow (92,000 gpm/loop)

- j. Steam generator tube plugging leveling (0% uniform)
- Maximizes reactor coolant volume and fluid release
 - Maximizes heat transfer area across the SG tubes
 - Reduces coolant loop resistance, which reduces the ΔP upstream of the break for the pump suction breaks and increases break flow
- k. The steam generator metal mass was modeled to include only the portion of the SGs which are in contact with the fluid on the secondary side. Portions of the SGs such as the head, upper shell and miscellaneous upper internals have poor heat transfer due to their location above the operating water level. The heat that is stored in this region is unavailable for release to containment and will not be able to effectively transfer energy to the RCS in the first 3600 seconds. Thus, this energy will be removed at a much slower rate and over a longer time period (>10000 seconds).

Additionally, there are some differences between Byron & Braidwood Unit 1 and Bryon & Braidwood Unit 2. Units 1 at each site have BWI replacement steam generators, whereas Unit 2 at each site have Westinghouse designed model D5 steam generators. Separate analytical models were generated for each steam generator type and were used for the calculations. Mass and Energy releases for both steam generator designs are provided herein.

Description of Analyses

The evaluation model used for the long-term LOCA mass and energy release calculations is the March 1979 model described in Reference 37. This evaluation model has been reviewed and approved generically by the NRC. The approval letter is included in Reference 37.

6.2.1.3.2 LOCA M&E Release Phases

The containment system receives mass and energy releases following a postulated rupture in the RCS. These releases continue over a time period, which, for the LOCA mass and energy analysis, is typically divided into four phases.

- a. Blowdown - the period of time from accident initiation (when the reactor is at steady state operation) to the time that the RCS and containment reach an equilibrium state.
- b. Refill - the period of time when the lower plenum is being filled by accumulator and ECCS water. At the end of blowdown, a large amount of water remains in the cold legs, downcomer, and lower plenum. To conservatively consider the refill period for the purpose of containment mass and energy releases, it is assumed that this water is instantaneously transferred to the lower plenum along with sufficient accumulator water to completely fill the lower plenum. This allows an uninterrupted release of mass and energy to containment. Thus, the refill period is conservatively neglected in the mass and energy release calculation.
- c. Reflood - begins when the water from the lower plenum enters the core and ends when the core is completely quenched.
- d. Post-reflood (Froth) - describes the period following the reflood phase. For the pump suction break, a two-phase mixture exits the core, passes through the hot legs, and is superheated in the steam generators prior to exiting the break as steam. After the broken loop steam generator cools, the break flow becomes two phase.

6.2.1.3.3 Computer Codes

The Reference 37 mass and energy release evaluation model is comprised of mass and energy release versions of the following codes: SATAN VI, WREFLOOD, FROTH, and EPITOME. These codes were used to calculate the long-term LOCA mass and energy releases for Byron Unit 1&2 and Braidwood Unit 1&2.

SATAN VI calculates blowdown, the first portion of the thermal-hydraulic transient following break initiation, including pressure, enthalpy, density, mass and energy flow rates, and energy transfer between primary and secondary systems as a function of time.

The WREFLOOD code addresses the portion of the LOCA transient where the core reflooding phase occurs after the primary coolant system has depressurized (blowdown) due to the loss of water through the break and when water supplied by the Emergency Core Cooling System refills the reactor vessel and provides cooling to the core. The most important feature of WREFLOOD is the steam/water mixing model.

FROTH models the post-reflood portion of the transient. The FROTH code is used for the steam generator heat addition calculation from the broken and intact loop steam generators.

EPITOME continues the FROTH post-reflood portion of the transient from the time at which the secondary equilibrates to containment design pressure to the end of the transient. It also compiles a summary of data on the entire transient, including formal instantaneous mass and energy release tables and mass and energy balance tables with data at critical times.

6.2.1.3.4 Break Size and Location

Generic studies have been performed with respect to the effect of postulated break size on the LOCA mass and energy releases. The double-ended guillotine break has been found to be limiting due to larger mass flow rates during the blowdown phase of the transient. During the reflood and froth phases, the break size has little effect on the releases.

Three distinct locations in the reactor coolant system loop can be postulated for pipe rupture for any release purposes:

- a. Hot leg (between vessel and steam generator)
- b. Cold leg (between pump and vessel)
- c. Pump suction (between steam generator and pump)

The break locations analyzed for this program are the double-ended pump suction (DEPS) rupture (10.48 ft²), and the double-ended hot leg (DEHL) rupture (9.18 ft²). Break mass and energy releases have been calculated for the blowdown, reflood, and post-reflood phases of the LOCA for the DEPS cases. For the DEHL case, the releases were calculated only for the blowdown. The following information provides a discussion on each break location.

The DEHL rupture has been shown in previous studies to result in the highest blowdown mass and energy release rates. Although the core flooding rate would be the highest for this break location, the amount of energy released from the steam generator secondary is minimal because the majority of the fluid which exits the core vents directly to containment bypassing the steam generators. As a result, the reflood mass and energy releases are reduced significantly as compared to either the pump suction or cold leg break locations where the core exit mixture must pass through the steam generators before venting through the break. For the hot leg break, generic studies have confirmed that there is no reflood peak (i.e., from the end of the blowdown period the containment pressure would continually decrease). Therefore, only the mass and energy releases for the hot leg break blowdown phase are calculated and presented in this section of the report.

The cold leg break location has also been found in previous studies to be much less limiting in terms of the overall containment energy releases. The cold leg blowdown is faster than that of the pump suction break, and more mass is released into the containment. However, the core heat transfer is greatly reduced, and this results in a considerably lower energy release into containment. Studies have determined that the blowdown transient for the cold leg is, in general, less limiting than that for the pump suction break. During reflood, the flooding rate is greatly reduced and the energy release rate into the containment is reduced. Therefore, the cold leg break is bounded by other breaks and no further evaluation is necessary.

The pump suction break combines the effects of the relatively high core flooding rate, as in the hot leg break, and the addition of the stored energy in the steam generators. As a result, the pump suction break yields the highest energy flow rates during the post-blowdown period by including all of the available energy of the RCS in calculating the releases to containment.

6.2.1.3.5 Application of Single-Failure Criterion

An analysis of the effects of the single-failure criterion has been performed on the mass and energy release rates for each break analyzed. An inherent assumption in the generation of the mass and energy release is that offsite power is lost. This results in the actuation of the emergency diesel generators, required to power the safety injection system. This is not an issue for the blowdown period, which is limited by the DEHL break.

Two cases have been analyzed to assess the effects of a single failure. The first case assumes minimum safeguards SI flow based on the postulated single failure of an emergency diesel generator. This results in the loss of one train of safeguards equipment. The other case assumes maximum safeguards SI flow based on no postulated failures that would impact the amount of ECCS flow. The analysis of the cases described provides confidence that the effect of credible failure is bounded.

The maximum safeguards case was previously shown to be less limiting than the minimum safeguards cases in the analyses performed for the stretch power uprate to 3586.6 MWt. Therefore, this case was not re-analyzed for the MUR uprate. Thus, the tables and figures for the maximum safeguards case are from the stretch power uprate analysis and do not reflect the MUR licensed thermal power level condition.

6.2.1.3.6 Acceptance Criteria for Analyses

A large break loss-of-coolant accident is classified as an ANS Condition IV event, an infrequent fault. To satisfy the Nuclear Regulatory Commission acceptance criteria presented in the Standard Review Plan Section 6.2.1.3, the relevant requirements are as follows:

- a. 10 CFR 50, Appendix A
- b. 10 CFR 50, Appendix K, paragraph I.A

In order to meet these requirements, the following must be addressed.

- a. Sources of Energy
- b. Break Size and Location
- c. Calculation of Each Phase of the Accident

6.2.1.3.7 Mass and Energy Release Data

6.2.1.3.7.1 Blowdown Mass and Energy Release Data

The SATAN-VI code is used for computing the blowdown transient. The code utilizes the control volume (element) approach with the capability for modeling a large variety of thermal fluid system configurations. The fluid properties are considered uniform and

thermodynamic equilibrium is assumed in each element. A point kinetics model is used with weighted feedback effects. The major feedback effects include moderator density, moderator temperature, and Doppler broadening. A critical flow calculation for subcooled (modified Zaloudek), two-phase (Moody), or superheated break flow is incorporated into the analysis. The methodology for the use of this model is described in Reference 37.

Tables 6.2-19 (Unit 1) and 6.2-34 (Unit 2) present the calculated mass and energy release for the blowdown phase of the DEHL break. For the hot leg break mass and energy release tables, break path 1 refers to the mass and energy exiting from the reactor vessel side of the break; break path 2 refers to the mass and energy exiting from the steam generator side of the break.

Tables 6.2-22 (Unit 1) and 6.2-37 present the calculated mass and energy releases for the blowdown phase of the DEPS break with minimum ECCS flows. Tables 6.2-28 (Unit 1) and 6.2-43 (Unit 2) presents the calculated mass and energy releases for the blowdown phase of the DEPS break with maximum ECCS flows. For the pump suction breaks, break path 1 in the mass and energy release tables refers to the mass and energy exiting from the steam generator side of the break; break path 2 refers to the mass and energy exiting from the pump side of the break.

6.2.1.3.7.2 Reflood Mass and Energy Release Data

The WREFLOOD code is used for computing the reflood transient. The WREFLOOD code consists of two basic hydraulic models - one for the contents of the reactor vessel, and one for the coolant loops. The two models are coupled through the interchange of the boundary conditions applied at the vessel outlet nozzles and at the top of the downcomer. Additional transient phenomena such as pumped safety injection and accumulators, reactor coolant pump performance, and steam generator release are included as auxiliary equations which interact with the basic models as required. The WREFLOOD code permits the capability to calculate variations during the core reflooding transient of basic parameters such as core flooding rate, core and downcomer water levels, fluid thermodynamic conditions (pressure, enthalpy, density) throughout the primary system, and mass flow rates through the primary system. The code permits hydraulic modeling of the two flow paths available for discharging steam and entrained water from the core to the break; i.e., the path through the broken loop and the path through the unbroken loops.

A complete thermal equilibrium mixing condition for the steam and ECCS injection water during the reflood phase has been assumed for each loop receiving ECCS water. This is consistent with the usage and application of the Reference 37 mass and energy release evaluation model in recent analyses, e.g., D. C. Cook Docket (Reference 38). Even though the Reference 37 model credits steam/water mixing only in the intact loop and not in the broken

loop; the justification, applicability, and NRC approval for using the mixing model in the broken loop has been documented (Reference 39). Moreover, this assumption is supported by test data and is further discussed below.

The model assumes a complete mixing condition (i.e., thermal equilibrium) for the steam/water interaction. The complete mixing process, however, is made up of two distinct physical processes. The first is a two-phase interaction with condensation of steam by cold ECCS water. The second is a single-phase mixing of condensate and ECCS water. Since the steam release is the most important influence to the containment pressure transient, the steam condensation part of the mixing process is the only part that need be considered. (Any spillage directly heats only the sump).

The most applicable steam/water mixing test data has been reviewed for validation of the containment integrity reflood steam/water mixing model. This data was generated in 1/3-scale tests (Reference 39), which are the largest scale data available and thus most clearly simulates the flow regimes and gravitational effects that would occur in a PWR. These tests were designed specifically to study the steam/water interaction for PWR reflood conditions.

A group of 1/3-scale tests corresponds directly to containment integrity reflood conditions. The injection flow rates for this group cover all phases and mixing conditions calculated during the reflood transient. The data from these tests were reviewed and discussed in detail in Reference 37. For all of these tests, the data clearly indicates the occurrence of very effective mixing with rapid steam condensation. The mixing model used in the containment integrity reflood calculation is therefore wholly supported by the 1/3-scale steam/water mixing data.

Additionally, the following justification is also noted. The post-blowdown limiting break for the containment integrity peak pressure analysis is the pump suction double-ended rupture break. For this break, there are two flow paths available in the RCS by which mass and energy may be released to containment. One is through the outlet of the steam generator, the other via reverse flow through the reactor coolant pump. Steam which is not condensed by ECCS injection in the intact RCS loops passes around the downcomer and through the broken loop cold leg and pump in venting to containment. This steam also encounters ECCS injection water as it passes through the broken loop cold leg, complete mixing occurs and a portion of it is condensed. It is this portion of steam, which is condensed, that is taken credit for in this analysis. This assumption is justified based upon the postulated break location, and the actual physical presence of the ECCS injection nozzle. A description of the test and test results are contained in References 37 and 39.

Tables 6.2-23 (Unit 1) and 6.2-38 (Unit 2), and Tables 6.2-29 (Unit 1) and 6.2-44 (Unit 2) present the calculated mass and energy releases for the reflood phase of the pump suction double-ended rupture, minimum safeguards, and maximum safeguards cases, respectively.

The transient response of the principal parameters during reflood are given in Tables 6.2-24 (Unit 1) and 6.2-39 (Unit 2), and Tables 6.2-30 (Unit 1) and 6.2-45 (Unit 2) for the DEPS minimum and maximum safeguards cases.

6.2.1.3.7.3 Post-Reflood Mass and Energy Release Data

The FROTH code (Reference 7) is used for computing the post-reflood transient. The FROTH code calculates the heat release rates resulting from a two-phase mixture present in the steam generator tubes. The mass and energy releases that occur during this phase are typically superheated due to the depressurization and equilibration of the broken loop and intact loop steam generators. During this phase of the transient, the RCS has equilibrated with the containment pressure, but the steam generators contain a secondary inventory at an enthalpy that is much higher than the primary side. Therefore, significant reverse heat transfer occurs. Steam is produced in the core due to core decay heat. For a pump suction break, a two-phase fluid exits the core, flows through the hot legs and becomes superheated as it passes through the steam generator. Once the broken loop cools, the break flow becomes two phase. During the FROTH calculation, ECCS injection is addressed for both the injection phase and the recirculation phase. The FROTH code calculation stops when the secondary side equilibrates to the saturation temperature (T_{sat}) at the containment design pressure, after this point the EPITOME code completes the SG depressurization.

The methodology for the use of this model is described in Reference 37. The mass and energy release rates are calculated by FROTH and EPITOME until the time of containment depressurization. After containment depressurization (14.7 psia), the mass and energy release available to containment is generated directly from core boiloff/decay heat.

Tables 6.2-25 (Unit 1) and 6.2-40 (Unit 2), and Tables 6.2-31 (Unit 1) and 6.2-46 (Unit 2) present the two-phase post-reflood mass and energy release data for the double-ended pump suction break, minimum and maximum safeguards cases.

6.2.1.3.7.4 Decay Heat Model

The American Nuclear Society (ANS) Standard 5.1 (Reference 40) was used in the LOCA mass and energy release model for the determination of decay heat energy. This standard was balloted by the Nuclear Power Plant Standards Committee (NUPPSCO) in October 1978 and subsequently approved. The official standard (Reference 40) was issued in August 1979. Table 6.2-49 lists the decay heat curve used in the M&E release analysis, post blowdown, for the Byron Units 1 & 2, and Braidwood Units 1 & 2 for the MUR program.

Significant assumptions in the generation of the decay heat curve for use in the LOCA M&E releases analysis include the following:

- a. Decay heat sources considered are fission product decay and heavy element decay of U-239 and Np-239.
- b. Decay heat power from fissioning isotopes other than U-235 is assumed to be identical to that of U-235.
- c. Fission rate is constant over the operating history of maximum power level.
- d. The factor accounting for neutron capture in fission products has been taken from Equation 11 of Reference 40, up to 10,000 seconds and from Table 10 of Reference 40, beyond 10,000 seconds.
- e. The fuel has been assumed to be at full power for 10^8 seconds.
- f. The number of atoms of U-239 produced per second has been assumed to be equal to 70 percent of the fission rate.
- g. The total recoverable energy associated with one fission has been assumed to be 200 MeV/fission.
- h. Two-sigma uncertainty (two times the standard deviation) has been applied to the fission product decay.

Based upon NRC staff review, Safety Evaluation Report (SER) of the March 1979 evaluation model (Reference 37), use of the ANS Standard-5.1, November 1979 decay heat model was approved for the calculation of M&E releases to the containment following a LOCA.

6.2.1.3.7.5 Steam Generator Equilibration and Depressurization

Steam generator equilibration and depressurization is the process by which secondary side energy is removed from the steam generators in stages. The FROTH computer code calculates the heat removal from the secondary mass until the secondary temperature reaches saturation (T_{sat}) at the containment design pressure. After the FROTH calculations, the EPITOME code continues the FROTH calculation for SG cooldown removing steam generator secondary energy at different rates (i.e., first and second stage rates).

The first stage rate is applied until the steam generator reaches T_{sat} at the user specified intermediate equilibration pressure, when the secondary pressure is assumed to reach the actual containment pressure. Then the second stage rate is used until the final depressurization, when the secondary reaches the reference temperature of T_{sat} at 14.7 psia, or 212°F. The heat removal of the broken loop and intact loop steam generators are calculated separately.

During the FROTH calculations, steam generator heat removal rates are calculated using the secondary side temperature, primary side temperature and a secondary side heat transfer coefficient determined using a modified McAdam's correlation. Steam generator energy is removed during the FROTH transient until the secondary side temperature reaches saturation at the containment design pressure. The constant heat removal rate used during the first heat removal stage is based on the final heat removal rate calculated by FROTH. The SG energy available to be released during the first stage interval is determined by calculating the difference in secondary energy available at the containment design pressure and that at the (lower) user specified intermediate equilibration pressure, assuming saturated conditions. This energy is then divided by the first stage energy removal rate, resulting in an intermediate equilibration time. At this time, the rate of energy release drops substantially to the second stage rate. The second stage rate is determined as the fraction of the difference in secondary energy available between the intermediate equilibration and final depressurization at 212°F, and the time difference from the time of the intermediate equilibration to the user specified time of the final depressurization at 212°F. With current methodology, all of the secondary energy remaining after the intermediate equilibration is conservatively assumed to be released by imposing a mandatory cooldown and subsequent depressurization down to atmospheric pressure at 3600 seconds, i.e., 14.7 psia and 212°F.

6.2.1.3.7.6 Sources of Mass and Energy

The sources of mass considered in the LOCA mass and energy release analysis are given in Tables 6.2-20 (Unit 1) and 6.2-35 (Unit 2) for the hot leg break, Tables 6.2-26 (Unit 1) and 6.2-41 (Unit 2) for the DEPS break minimum safeguards case, and Tables 6.2-32 (Unit 1) and 6.2-47 (Unit 2) for the DEPS break maximum safeguards case. These sources are the reactor coolant system, accumulators, and pumped safety injection.

The energy inventories considered in the LOCA mass and energy release analysis are given in Tables 6.2-21 (Unit 1) and 6.2-36 (Unit 2) for the hot leg break, Tables 6.2-27 (Unit 1) and 6.2-42 (Unit 2) for the DEPS break minimum safeguards case, and Tables 6.2-33 (Unit 1) and 6.2-48 (Unit 2) for the DEPS break maximum safeguards case. The energy sources include:

B/B-UFSAR

- a. Reactor Coolant System Water.
- b. Accumulator Water (all four inject).
- c. Pumped Safety Injection Water.
- d. Decay Heat.
- e. Core Stored Energy.
- f. Reactor Coolant System Metal (includes SG tubes).
- g. Steam Generator Metal (includes transition cone, shell, wrapper, and other internals, located below the operating water level).
- h. Steam Generator Secondary Energy (includes fluid mass and steam mass).
- i. Secondary Transfer of Energy (feedwater into and steam out of the steam generator secondary).

Energy Reference Points:

- a. Available Energy: 212°F; 14.7 psia
(All energies in the system are assumed to be taken out to these conditions in the first hour of the event).
- b. Total Energy Content: 32°F; 14.7 psia
(Reference point for the system energy).

The mass and energy inventories are presented at the following times, as appropriate:

- a. Time zero (initial conditions).
- b. End of blowdown time.
- c. End of refill time.
- d. End of reflood time.
- e. Time of broken loop steam generator equilibration to pressure setpoint.
- f. Time of intact loop steam generator equilibration to pressure setpoint.
- g. Time of full depressurization (3600 seconds).

In the mass and energy release data presented, no Zirc-water reaction heat was considered because the clad temperature is assumed not to rise high enough for the rate of the Zirc-water reaction heat to be of any significance.

The sequence of events for the LOCA transients are shown in Table 6.2-6 (Unit 1, DEPS break, minimum SI), Table 6.2-6a (Unit 2, DEPS break, minimum SI), Table 6.2-7 (Unit 1, DEHL break), and Table 6.2-8 (Unit 2 DEHL break).

6.2.1.3.8 Conclusions

The consideration of the various energy sources in the long-term mass and energy release analysis, including the BWI SG (Unit 1) and the Westinghouse D5 SG (Unit 2), provides assurance that all available sources of energy have been included in this analysis. Thus, the review guidelines presented in Standard Review Plan Section 6.2.1.3 have been satisfied.

6.2.1.4 Mass and Energy Release for Postulated Secondary System Pipe Breaks Inside Containment (PWR)

The containment structure receives mass and energy releases following a postulated break of the steam or feedwater line. A spectrum of main steamline break (MSLB) accidents covering different break areas and reactor operating power levels is analyzed. These are discussed in the following subsections.

The LOFTRAN code is used to model the heat transfer in the MSLB blowdown model for Unit 1 and Unit 2. The heat transfer in the core is calculated based on a nodal analysis employing implicit backward difference methodology. The heat transfer rate is based on two modes of heat transfer.

- a. Subcooled forced convection and
- b. Nucleate boiling (using the Jens-Lottes' correlation).

For a more detailed discussion on heat transfer models used in LOFTRAN, refer to WCAP 7907.

A feedwater pipe break inside containment is not analyzed because it is not as severe as the main steamline break, since the break effluent is at a lower specific enthalpy.

6.2.1.4.1 Pipe Break Blowdowns - Spectra and Assumptions

A series of steamline breaks were analyzed to determine the most severe break condition for containment temperature and pressure response. The following assumptions were used in the analysis:

- a. Breaks were assumed to be either double-ended breaks occurring at the nozzle at one steam generator or split breaks.
- b. Blowdown from the broken steamline is assumed to be saturated steam.
- c. For Unit 1 and Unit 2, steamline isolation is assumed to be completed 8 seconds after the isolation setpoint is reached, and feedline isolation is assumed to be completed 7 seconds after the isolation setpoint is reached. The assumed closure times allow for signal generation, processing, and delay. The steamline isolation signal is generated by either a low steamline pressure, high-2 containment pressure, or high steamline rate of pressure decrease. The feedwater isolation signal is generated by either a safety injection, P-4 (reactor trip) with coincident LO T_{ave}, or S/G high-2 level. For the steam line break analyses, feedwater isolation results from a safety injection signal.
- d. Analyses have been done at a range of power levels from hot zero power to full power plus calorimetric uncertainty. Cases were evaluated at initial power levels of 100%, 70%, 30% and 0%. The results presented provide the most limiting cases from the set of power levels described above, and the composite results include the results of all these cases.

- e. The double-ended breaks were evaluated for a full double-ended guillotine (1.1 ft²) and a small double-ended guillotine (1.0 ft²) for Unit 1 and a full double-ended guillotine (1.4 ft²) and a small double-ended guillotine (1.0 ft²) for Unit 2. The split breaks were evaluated at 1.0 ft², 0.96 ft², 0.90 ft² and 0.64 ft² for Unit 1 and 0.81 ft², 0.82 ft², 0.83 ft² and 0.62 ft² for Unit 2. Steamline flow restrictors in the steam generators limit the effective break area of a full double-ended pipe break to 1.1 ft² per steam generator for Unit 1 and 1.4 ft² per steam generator for Unit 2 after steamline isolation. Initially, the effective flow area for reverse flow is the full pipe flow area. After the first few seconds of the transient, the reverse flow is limited by the size of the steam generator flow restrictor. Reverse flow continues until steamline isolation.

B/B-UFSAR

- f. Failures of a main steam isolation valve, a diesel generator, and a feedwater isolation valve were considered.
- g. The auxiliary feedwater system is manually realigned by the operator within 30 minutes by isolating auxiliary feedwater flow from the depressurized steam generator.

Liquid entrainment was not assumed in the MSLB analysis for the Unit 1 and Unit 2 steam generators.

6.2.1.4.2 Description of Blowdown Modeling

The following is a description of the break flow modeling of the blowdown of the steam generators and plant steam piping:

a. Steam Generator Blowdown

Break flows and enthalpies from the steam generators are calculated using the Westinghouse LOFTRAN code for Unit 1 and for Unit 2 (Reference 32). Blowdown mass and energy release were determined using the LOFTRAN Code, including effects of core power generation, main and auxiliary feedwater additions, engineered safeguards systems, reactor coolant system thick metal heat storage, and reverse steam generator heat transfer.

b. Steam Plant Piping Blowdown

The contribution to the mass and energy releases from the secondary plant steam piping is included in the mass and energy release calculations. The flow rate is determined using the Moody correlation, and modeling considerations include the pipe cross-sectional area, the steam generator flow restrictor area, and the area of the break. The steam piping blowdown calculations consider the initial steam in the piping as well as the reverse flow from the intact steam generators until steamline isolation.

The blowdown model is further discussed in Reference 32.

6.2.1.4.3 Single Failure Analysis

The following single failures were evaluated to determine the limiting set of conditions for this analysis:

- a. Failure of a main steam isolation valve (MSIV) increases the volume of steam piping which is not isolated from the break. When all valves operate, the piping volume capable of blowing down is located between the steam generator and the first isolation valve. If this valve fails, the volume between the break and the isolation valves in the other steamlines including safety and relief valve headers and other connecting lines will feed the break.
- b. Failure of a diesel generator would result in the loss of one containment safeguards train resulting in minimum heat removal capability. However, a diesel generator failure is only considered for cases that assume a loss of offsite power. For cases that assume offsite power is available, the limiting single failure in the containment safeguards system for MSLB was determined to be the failure of one RCFC train that results in the loss of 2 RCFC

units. Failure of one CS pump was shown, by plant-specific analyses to be less limiting than the failure of one RCFC train.

- c. Failure of the main feedwater pump trips would result in additional inventory supplied to the steam generator before feedwater isolation. In the analysis, feedwater pump trip was ignored, which is conservative as it allows increased blowdown. Therefore, the failure of a feedwater pump to trip was not analyzed as a separate failure.
- d. Failure of a feedwater isolation valve could only result in additional inventory in the feedwater line which would not be isolated from the steam generator. The mass in this volume can flash into steam as it enters the steam generator and subsequently exit through the break. Both the feedwater isolation valve and the feedwater regulating valve close in no more than 5 seconds, precluding the pumping of any additional feedwater into the steam generator. The additional line volume available to flash into steam as it enters the steam generator is that between the feedwater isolation valve and the feedwater regulating valve, including all headers and connecting lines.

The resultant mass and energy release rates for the limiting steam pipe break are presented in Tables 6.2-50, 6.2-50a, 6.2-50b, and 6.2-50c. The containment peak pressures and temperatures for the secondary side breaks that make-up the composite curves are listed in Tables 6.2-1 and 6.2-1a.

For Unit 1 and Unit 2, the worst-case single failure for maximizing the peak pressure response is failure of a main steamline isolation valve to close with offsite power available. The worst case single failure for maximizing the containment peak temperature is failure of the main steamline isolation valve to close without offsite power.

The mass and energy releases given in Tables 6.2-50, 6.2-50a, 6.2-50b, and 6.2-50c are based on the appropriate worst-case single failure, as discussed above. The feedwater and main steam isolation valve closure times associated with the mass and energy release data in Tables 6.2-50, 6.2-50a, 6.2-50b, and 6.2-50c are given in Tables 6.2-9, 6.2-9a, 6.2-9b, and 6.2-9c.

6.2.1.5 Minimum Containment Pressure Analysis for Performance Capability Studies of Emergency Core Cooling System (PWR)

The containment backpressure used for the large break ECCS analyses presented in Section 15.6.5.2.1 are presented in Figures 6.2-24a and 6.2-24b for Units 1 and 2, respectively. The containment backpressure is calculated using the methods and assumptions described in Reference 1 and Appendix A of Reference 12. Input parameters, including the containment initial conditions; net free containment volume; passive sink materials, thicknesses, and surface areas; and starting time and number of containment cooling systems used in the analysis, are described in Subsections 6.2.1.5.1 through 6.2.1.5.8.

A large break LOCA analysis conservatively modeled the reduction in the minimum containment backpressure resulting from open miniflow purge lines when the break is initiated. The mini-purge system consists of two 8-inch diameter lines with isolation valves that have a 5-second closure time. The actuation signal to close the mini-purge lines comes from the containment pressure high-1 signal, with an additional signal delay time of 2 seconds. During the time the mini-purge valves are open, flow occurs through the lines. This flow from the containment will reduce the containment backpressure. Due to the difficulty in explicitly modeling this containment response, a simplifying methodology was used. The containment volume input was increased to conservatively offset the pressure reduction due to flow out of the mini-purge system. Thus, the LOCA results have incorporated the effects of containment purge and still meet the 10 CFR 50.46 requirements.

6.2.1.5.1 Mass and Energy Release Data

The mass/energy releases to the containment transient are presented in Tables 6.2-51 and 6.2-52. The mass and energy releases from the spilling broken loop accumulator and broken loop safety injection are given in Table 6.2-53.

The mathematical models which calculate the mass and energy releases to the containment are described in Subsection 15.6.5.2.1. The mass and energy releases for each reference transient case are used in COCO program to calculate the containment response. The COCO results were compared to the backpressure inputs assumed in the reference transient and shown to be conservative for both Unit 1 and Unit 2. For the two analyses, the same reference transient backpressure inputs were used throughout the remaining analysis cases. The Unit 1 and Unit 2 backpressure curves are presented in Figures 6.2-24a and 6.2-24b, respectively.

6.2.1.5.2 Initial Containment Internal Conditions

The following initial values were used in the analysis:

Containment pressure	14.2 psia
Containment temperature	60°F
RWST temperature (for containment spray and spilling safety injection)	32°F
Outside temperature	-25°F
Relative humidity	100%

The containment initial conditions of 60°F and 14.2 psia are representatively low values anticipated during normal full-power operation.

6.2.1.5.3 Containment Volume

The conservatively high estimate of net free containment volume used in the original safety analysis is $3.10 \times 10^6 \text{ ft}^3$. In order to account for the effects of the mini-purge system as described in Subsection 6.2.1.5, the volume was increased to $3.20 \times 10^6 \text{ ft}^3$ in the analysis.

6.2.1.5.4 Active Heat Sinks

The containment spray system and the containment atmosphere recirculation system fan coolers operate to remove heat from the containment.

A large break LOCA analysis has been performed for the Byron/Braidwood Stations incorporating revised fan cooler and containment spray initiation times (see Table 6.2-54). The analysis is based upon a fan cooler minimum essential service water temperature of 32°F. The temperature versus heat load performance is provided in Table 6.2-54 for the estimated capacity of one fan cooler.

The sump temperature was not used in the analysis because the maximum peak cladding temperature occurs prior to initiation of the recirculation phase for the containment spray system. In addition, heat transfer between the sump water and the containment vapor space was not considered in the analysis.

6.2.1.5.5 Steam-Water Mixing

Water spillage rates from the broken loop accumulator and broken loop safety injection are included in the containment (COCO) code calculation model. Table 6.2-53 summarizes these boundary conditions.

6.2.1.5.6 Passive Heat Sinks

The passive heat sinks used in the analysis and their thermophysical properties are given in Table 6.2-55.

Table 6.2-55 was generated by calculating conservatively large areas and thicknesses. A complete and detailed list of surface areas and thicknesses of structures and equipment in the containment was compiled. Where applicable, an uncertainty of from +10 to +25% was assigned to each calculated area. The containment wall area, which was assumed to have 0% uncertainty, was increased by 10% in order to ensure conservatism. The values in Table 6.2-55 provide a conservative (high) estimate of the containment heat sinks for use in the minimum containment pressure analysis.

6.2.1.5.7 Heat Transfer to Passive Heat Sinks

The condensing heat transfer coefficients used for heat transfer to the steel containment structures is given in Figure 6.2-26 for the reference transient. The containment air temperature transient for the reference transient is shown in Figure 6.2-27.

6.2.1.5.8 Other Parameters

No other parameters have a substantial effect on the minimum containment pressure analysis.

6.2.1.6 Testing and Inspection

6.2.1.6.1 Structural Acceptance Test

For a discussion of the structural acceptance test see Subsection 3.8.1.7.

6.2.1.6.2 Preoperational Leakage Rate Test

The containment leakage testing program will be performed in accordance with 10 CFR 50, Appendix J. This document establishes frequency, methods, and acceptance criteria. The purpose of the test is to confirm that the actual containment leakage rate is within the design requirement. The reduced pressure leakage rate test is performed to provide baseline information for future tests. Containment leakage testing is further described in Section 6.2.6.

In addition to the initial containment Type A leakage rate tests at full and reduced pressure the following Type B and Type C tests of 10 CFR 50 Appendix J will be performed on the indicated components:

Type B Test

- a. Electrical penetrations Zones 1 through 4
- b. Fuel transfer tube
 1. Containment side blind flange (double O-rings)
- c. Equipment door/integral personnel airlock
 1. Equipment door seals - double O-rings
 2. Airlock door seals - double lip gasket
 3. Personnel airlock pressurization
 4. One inch test penetration flange double O-rings

- d. Emergency personnel lock
 - 1. Airlock doors seals - double lip gasket
 - 2. Personnel airlock pressurization
 - 3. One inch test penetration flange double O-rings
- e. Containment pressurization penetration (PC-4)
- f. Spare containment penetrations (PC-63, PC-64 & PC-74)

Type C Test

Containment isolation valves as identified in Table 6.2-58.

6.2.1.6.3 Inservice Leakage Rate Testing

Periodic leakage rate testing of the containment will be performed in accordance with 10 CFR 50 Appendix J, Option B as modified by approved exceptions in Technical Specification 5.5.16.

6.2.1.6.4 Tendon Surveillance Program

For a discussion of the tendon surveillance program see the Technical Specifications.

6.2.1.7 Instrumentation Requirements

The containment is provided with instrumentation to monitor the conditions in the containment over the full operating range of the plant. Containment air sampling and radiation monitoring are described in Subsections 11.5.2.2 and 12.2.2.

The components and subsystems to the containment system that require actuation to initiate the safety function are described in Subsection 6.2.4 and Section 6.5.

Containment pressure and temperature are indicated on the main control board. The following ventilation equipment temperature elements are monitored by the computer;

- a. control rod drive shroud air inlet,
- b. control rod drive booster fan air outlet,
- c. hot leg nozzle air outlet,
- d. out-of-core neutron monitors air outlet, and
- e. containment fan cooler return air.

For containment pressure, the requirements of NUREG-0737 and Regulatory Guide 1.97 are met by pressure transmitters with diaphragm seals.

The existing pressure measurement instrumentation consists of four channels, with each channel having a range of 0 to 60 psig. The four channels provide inputs to the reactor protection system. Additional containment wide range pressure measurement instruments are provided as follows:

1. Qualified to IEEE 323-1974 and IEEE 344-1975.
2. Two channels are provided with one transmitter/diaphragm seal in each.
3. The range of each channel is 5 psia to 150 psig.
4. Continuous display and recording are provided in the main control room.

For Byron and Braidwood containment wide range water level (PC006 and PC007), the requirements of NUREG-0737 and Regulatory Guide 1.97 are met by differential pressure transmitters with diaphragm seals. For Byron Unit 1 and Braidwood Unit 1 narrow range containment water level (Containment Floor Drain Sump Level Instruments - PC002 and PC003), the requirements of NUREG-0737 and Regulatory Guide 1.97 are met by differential pressure transmitters with diaphragm seals. For Byron Unit 2 narrow range containment water level, the requirements of NUREG-0737 and Regulatory Guide 1.97 are met by float-type resistance level transmitters with signal conditioners. For Braidwood Unit 2 narrow range containment water level, the requirements of NUREG-0737 and Regulatory Guide 1.97 are met by a thermal dispersion type level measurement system.

Two channels of level measurement are provided for each application of containment level as follows:

1. Qualified to IEEE 323-1974 and IEEE 344-1975.
2. Containment wide range water level is measured from the bottom of containment to the equivalent level of 600,000 gallons of water. (PC006 and PC007).
3. The low reference point for containment water level and containment floor drain sump level is as near containment bottom and containment floor drain sump bottom; respectively, as physically possible.
4. The main control room display/recording requirements of Regulatory Guide 1.97 are met for containment water level and containment floor drain sump level.

Reactor support concrete temperatures are indicated inside containment.

Refer to Section 7.3 for design details.

6.2.2 Containment Heat Removal System

The containment heat removal system consists of the reactor containment fan cooler system and the containment spray system. The reactor containment fan cooler system has no emergency function other than containment heat removal, while the primary function of the containment spray system is the removal of iodine and other radionuclides from the containment atmosphere.

The containment spray system is designed to operate following a LOCA to reduce the iodine concentration of the containment atmosphere and to raise the pH of the containment sump by adding NaOH, to ensure that the iodine removed from containment atmosphere will be retained in the sump solution. When the RWST reaches the Lo-3 level, the system is isolated from the RWST and plant valves are aligned for CS pump operation with suction from the recirculation sump. When the required quantity of NaOH has been added to the recirculation sump, the spray additive tank is isolated. (It should be noted that after 30 minutes most of the heat removal from containment is provided by the reactor containment fan coolers, which are safety grade for Byron/Braidwood.) Sprays are not required for long-term heat removal. Nevertheless, the containment sprays will be operated for at least 8 hours following a LOCA before they are terminated.

The RHR, CV, and SI systems are designed to operate following a LOCA to cool the reactor core. These systems are switched from injection to recirculation when the RWST reaches the Lo-2 level and remain in operation for the remainder of the accident. Additional fuel clad failure is not postulated while these systems are operating.

The containment spray system is discussed in Subsection 6.5.2, and the performance of both the reactor containment fan cooler system and the containment spray system under the design-basis loss-of-coolant accident condition is evaluated in Subsection 6.2.1.1.

The containment heat removal system rejects heat to the ultimate heat sink. Containment analyses to support the design bases of the ultimate heat sink are described in Subsection 9.2.5.

6.2.2.1 Design Bases

The containment heat removal system is designed in accordance with General Design Criteria 38, 39, 40, and 50 (see Section 3.1).

6.2.2.1.1 Reactor Containment Fan Cooler (RCFC) System

The reactor containment fan cooler system is designed to meet the following requirements:

- a. During normal conditions, the system cools and dehumidifies the containment to meet the operating environment required by the mechanical, electrical, and structural components within the containment. These environments are described in Section 3.11.1 under normal conditions.
- b. The RCFC system, the emergency core cooling system, and the containment spray system share in removing energy released following a postulated loss-of-coolant accident. Source of energy and energy release rate and the response of the containment atmosphere to the energy released and to the containment heat removal system are addressed in Subsection 6.2.1.
- c. Blowdown and heat removal analysis is based on the availability of at least one of the two redundant trains provided by the RCFC system, containment spray system, and emergency core cooling system.
- d. The RCFC system is designed for full operation within 40 seconds following the initiation of safety actuation signal and will continue to operate over an extended period of time under the environmental conditions existing thereafter. Following a design basis accident concurrent with a loss of offsite power, the analysis assumptions regarding RCFC actuation allow for an extended RCFC startup delay in order to account for startup of the essential service water system. See Subsection 6.2.1 for more information.
- e. The RCFC system components are designed to operate and to meet the design performance under the postulated loss-of-coolant accident conditions.
- f. As described in Subsection 6.2.2.1.1(c) above, minimum required number of components can be available considering a single failure.
- g. All components essential to the operation of the RCFC system are designed to withstand the safe shutdown earthquake without loss of function.

- h. The RCFC system components, including fan, motor, service water cooling coils, housing, and ductwork, are designed to withstand the dynamic effect resulting from a transient pressure difference

between the various subcompartments inside the containment during a loss-of-coolant accident.

- i. During normal operating conditions, only one of the two redundant trains is required to meet normal containment cooling requirements. The equipment manufacturer's recommendations and station practices were considered in determining required maintenance.

6.2.2.1.2 Containment Spray System

For a discussion of the heat removal capabilities of the containment spray system, see Subsection 6.5.2.1.

6.2.2.2 System Design

6.2.2.2.1 Reactor Containment Fan Cooler (RCFC) System

The RCFC system is shown in Drawings M-103 and M-104. Description of system operation and design requirements under normal operating conditions is given in Subsection 9.4.8. Description of system operation and design requirements under post-LOCA accident conditions is summarized as follows:

- a. All system components that are required to support system operation following a loss-of-coolant accident are classified as engineered safety feature system and are designed to Safety Category I requirements.
- b. Design performance data are given in Table 6.2-56.
- c. Two redundant trains are provided. Each is powered from a separate redundant essential bus. Each train consists of two 50%-capacity RCFC units. Each unit consists of the following components:

1. Fan/Motor Assembly

One vane-axial fan is provided and directly driven by a totally enclosed air over (TEAO) 2-speed motor. The motor is cooled by direct containment air atmosphere flowing over the motor.

At Byron Units 1 and 2, motor space heaters are provided for each fan motor to maintain favorable conditions of temperature and humidity in their environment during shutdown periods.

During normal operating conditions, the RCFC fan motor operates in the high-speed mode. On initiation of post-LOCA mode of operation, the

motor will shift to low speed, resulting in lower airflow. The lower airflow compensates for the increase in containment air density resulting from the higher pressure and humidity following a loss-of-coolant accident.

2. Essential Service Water (ESW) Cooling Coil Assembly

Ten finned tube essential service water coil sections are provided for each RCFC unit. Drain troughs are provided to collect and remove essential service water coil condensate.

The ESW cooling coils are designed to meet the entire cooling requirements following a loss-of-coolant accident; however, during normal operation, these coils (with the same essential service water flow rate required for postaccident heat removal) remove containment heat consistent with the essential service water and containment temperatures. The balance of heat removal during normal operation will be transferred in the independent chilled water coils described below.

3. Chilled Water Cooling Coil Assembly

Chilled water is used through an independent coil mounted in series with the essential service water cooling coil to supplement essential service water cooling capability under normal operation only. The chilled water system is Safety Category II, Quality Group D, except for containment penetrations and some of the piping within the containment. The chilled water is provided by refrigeration units located outside the containment. The condensers of the refrigeration units are cooled by the essential service water return from the essential service water cooling coil sections during normal operation. Upon receipt of safeguards actuation signals, the Safety Category II chilled water condensers are automatically isolated from the Safety Category I essential service water system.

4. Check Dampers

The RCFC discharges directly into the lower containment volume. Due to limited vent areas to the upper containment volume, the lower

volumes will pressurize more rapidly than the upper volume following a LOCA.

To protect the RCFC fans and motors against possible adverse effects of transient induced reversed flow, check dampers are provided in the discharge ductwork. One check damper is provided for each RCFC unit. The dampers are spring operated and will close under any conditions where reverse flow is experienced in the fan discharge duct.

The RCFC check dampers, have been tested to ensure a closure time of 0.1 second during an accident. Pressure drop and leakage tests were also performed and the results were within acceptable limits. The results of the ESW cooling coil assembly performance test show a good correlation between the test results and the anticipated thermal performance at relatively low temperature and pressure. At higher temperature and pressures, the test results indicate performance which is 10% to 20% higher than anticipated.

5. Housing and Ductwork

During all operating conditions air is drawn from the upper volume of the containment approximately 50 feet above the operating floor by a return air riser (one riser for each RCFC unit). The return air is then routed through the ESW cooling coils, the chilled water cooling coils, and the fan and discharge duct (one for each RCFC unit) where the backdraft damper is located. The RCFC housing encloses the cooling coils (both ESW and chilled water) and the fan/motor assembly.

- d. As discussed in Subsection 6.2.2.1.1, only one of the two redundant trains is required to operate under all operating conditions. Rotating the operating train and periodic starting of the standby train assures the system availability. The RCFC system components are located outside the secondary shield wall where radiation exposure to operators is kept at a minimum. Access doors and maintenance platforms and gratings are provided to facilitate operator access to system components.
- e. Governing codes and standards and quality group classifications utilized in designing the system components are listed in Table 3.2-2 and discussed under Subsection 3.2.

- f. Plant protection signals and setpoints are discussed in Section 7.3. While the actuation of the emergency core cooling system (ECCS) takes the first priority in initiation and in emergency power supply, the containment spray system takes second priority, and the RCFC system takes third priority following the initiation of the ECCS and the containment spray system. The containment spray system provides short-term cooling, while the RCFC system provides long-term cooling. Sequencing time of the above initiation is selected governed by the maximum rate of loading on the emergency diesel generator.
- g. The essential cooling water is maintained continuously through the ESW cooling coils of the operating RCFC units and is made available whenever the corresponding RCFC fans are operated. Also, the RCFC fans in the operating train are continuously running at the high-speed mode. Following a loss-of-coolant accident signal, the operating fans will trip and commence operation on the low-speed mode following a 20-second time delay. The RCFC fans which were not operating during normal operation will also commence operation on low speed 20 seconds after receipt of the initiating signal.
- h. As discussed in Section 7.3, no operator action is required for the post-LOCA accident operation of the RCFC System.
- i. The following qualification tests have been performed on the RCFC system components:
 - 1. Fan/Motor Assembly

Fan/motor assemblies similar to those installed for the Byron/Braidwood Stations have been tested under simulated loss-of-coolant accident environment and in accordance with the requirements of IEEE 323-1974 and IEEE 334-1971. The assembly has been also qualified to meet the requirements of IEEE 344-1971. Subsections 3.10 and 3.11 address the qualification to IEEE 323-1974 and IEEE 334-1971.
 - 2. Essential Service Water Cooling Coil Assembly

Performance testing was performed for the ESW cooling coils assembly. A mathematical model was developed to verify the test results. The coils meet the requirements of ASME Code Section III, Class 3, and were

hydrostatically tested to the code requirements. The coils will be qualified analytically to withstand the dynamic effect of the loss-of-coolant accident concurrent with the design-basis seismic event.

Analyses performed in response to NRC Generic Letter 96-06 indicated that, even though there was a potential for limited steam voiding to occur in the RCFC cooling coil piping during loss-of-coolant accident conditions, the calculated stresses in the limiting piping subsystem remained within design allowables. These analyses are contained in References 33 and 34.

3. Chilled Water Cooling Coil Assembly

The chilled water cooling coil assembly was hydrostatically tested to the requirements of ASME Code Section VIII. The coils and their supports are designed to retain their structural integrity during the design-basis seismic event to assure continuity of function of the adjacent essential service water cooling coils.

4. Check Dampers

The check dampers have been tested under conditions similar to the postulated dynamic effect of the loss-of-coolant accident.

5. Housing and Ductwork

No test was provided for the housing or the ductwork. The RCFC housing is designed for a transient pressure of 5 psid and the RCFC return air riser is designed for a transient pressure of 3 psid.

6.2.2.2.2 Containment Spray System

Refer to Subsection 6.5.2.2.

6.2.2.3 Design Evaluation

6.2.2.3.1 Reactor Containment Fan Cooler (RCFC) System

- a. The evaluation of the reactor containment fan cooler performance under the design-basis loss-of-coolant accident conditions is presented in Subsection 6.2.1.

- b. The reactor containment fan coolers provide the design heat-removal capacity for the containment following a loss-of-coolant accident, assuming that the core residual heat is released to the containment as steam. The system will accomplish this by continuously recirculating the air-steam mixture through cooling coils to transfer heat from containment to essential service water.

- c. Any two of the four RCFC units will provide sufficient heat-removal capability to maintain the containment pressure below the design value following a loss-of-coolant accident.
- d. The starting sequence and timing for the RCFC units following a loss-of-coolant accident with loss of offsite power are described in Section 8.3.
- e. A failure analysis has been made on all active components of the system to assure that the failure of any single active component will not prevent fulfilling the design function. The 100% redundancy in the RCFC units fulfills this criterion (see Table 6.2-57).
- f. The principal systems which are interconnected with the reactor containment fan cooler system are the essential service water system and the ESF electrical buses. The essential service water supply to the fan coolers is a redundant system such that the failure of any one single component or pipe will not reduce the cooling capacity of the RCFC units below that required for either accident or normal operational modes. The essential service water system is described in Subsection 9.2.1. Chilled water is not required after an accident, and the failure of any chilled water system component cannot interact to adversely affect the RCFC operation, since it is isolated from the essential service water system. Electrical power to the RCFC fans will be supplied from the emergency diesel generators upon loss of auxiliary power. The electrical system is described in Section 8.3.
- g. The basic design of the motor as described herein is such that the incident environment is prevented from entering the motor winding.
- h. The motor stator winding temperature rise (by embedded detector) is 65° above 50°C ambient when operating at full load. Insulation is Class H.
- i. During the lifetime of the plant, these motors perform the normal heat-removal service and as such are loaded to only approximately 85% of their nominal rating.
- j. The bearings are designed to perform in the accident ambient temperature conditions.

- k. The motor insulation has high resistance to moisture. Tests have been performed to indicate that the insulation system will survive the incident ambient moisture condition without failure.
- l. In addition, it should be noted that at the time of the postulated accident, the load on the fan motor would increase internal motor temperature and would therefore tend to drive any moisture out of the winding. Additionally, the motors are furnished with insulation voltage margin beyond the operating voltage.
- m. Performance test of the ESW cooling coils is based on testing a representative coil section under simulated containment atmosphere of air and water vapor while it is cooled by water at design temperature. The cooling coil performance under fouling conditions is determined by the same analytical method which is verified by test under the clean conditions. A fair agreement between the calculated and the test performance verifies the soundness of the analytical method and justifies its applicability to the prediction of equipment performance under fouled conditions.
- n. The RCFC system is designed with adequate monitoring to demonstrate system availability at all modes of operation.
- o. The system components are designed, fabricated, tested and installed in accordance with codes, standards, and quality groups identified in Subsection 3.2.1.

6.2.2.3.2 Containment Spray System

For a discussion of the design evaluation of the containment spray system, refer to Subsection 6.5.2.3.

6.2.2.4 Tests and Inspections

6.2.2.4.1 Reactor Containment Fan Cooler (RCFC) System

- a. Testing of the RCFC system is performed prior to plant operation in accordance with the procedures described in Chapter 14.0.
- b. The RCFC system will operate continuously during normal operation of the plant. Malfunction of system components can be detected

and corrected as necessary. This design further enhances the reliability of the system to perform its intended function following a postulated loss-of-coolant accident.

- c. Testing provisions are incorporated in the system design to enable periodic evaluation of the operability and performance of system components and to permit periodic flow continuity and hydrostatic tests.
- d. Visual inspection and maintenance of the RCFC System components will be conducted during each refueling period.
- e. Components, valves, and piping will be inspected in accordance with ASME Section XI and ASME Section III where applicable.
- f. Opening of containment isolation valves upon receipt of an actuation signal is checked to demonstrate the proper operation of the remotely operated valves.

The reactor containment fan coolers and portions of the associated essential service water supply and return piping between the outermost containment isolation valves were supplied and constructed to Quality Group C requirements (ASME Section III, Class 3).

In order to provide a level of quality equivalent to Quality Group B standards, additional ASME Section III Class 2 nondestructive examinations were performed on the RCFC essential service water cooling coils (magnetic particle examination on RCFC coil nozzle joint at water box header and radiograph examination of the flange connection to the nozzle). In addition, ASME Section III Class 2 nondestructive examinations were performed on the Quality Group C essential service water piping portions serving the RCFC coils (radiographic examination of the circumferential weld joints).

Following is the justification to demonstrate that by performing magnetic particle examination on the fillet welds and radiographic examination on the butt welds, these coils will meet Class 2 NDE requirements:

- a. The RCFC coils are made of seamless copper tubes, formed and machined in one piece with end tube sheets.
- b. The return bends are brazed to the tubes on one end. The NDE requirements are the same for brazing processes for Class 2 and Class 3.

- c. The water boxes are made in one piece with no joints and bolted to the tube sheet on the other end of the coil. Welded baffles in the box are internal to the box and hence are not in containment pressure boundary.

The pressure boundary welds associated with replacement essential service water RCFC water boxes, piping and components classified as ASME Quality Group C, shall be inspected in accordance with ASME Section III, Class 2 requirements to ensure Quality Group B standards, are maintained. Replacement RCFC essential service water coils, components or associated piping may be supplied, examined and installed in accordance with ASME Section III, Class 2 requirements.

For subsequent inservice inspections, these lines shall be treated as all other Class 2 lines. They will be included into the Byron/Braidwood Stations ASME Section XI inservice inspection NDE program and will receive all code required examinations. However, these lines are covered by the following exemptions:

- a. IWC-1220 (b) exempts components of systems or portions of systems, other than residual heat removal systems and emergency core cooling systems, that are not required to operate above a pressure of 275 psig (1900kPa) or above a temperature of 200°F (93°C).
- b. IWC-1220 (c) exempts component connections (including nozzles in vessels and pumps), piping and associated valves and vessels (and their supports) that are 4 inch nominal pipe size and smaller.

The subject lines operate at 75 psig and a temperature of 189°F. Portions of these lines are 4 inch and smaller. Therefore, the aforementioned lines are subject to Section XI VT-2 examinations only.

6.2.2.4.2 Containment Spray System

For a discussion of testing and inspection of the containment spray system, see Subsection 6.5.2.4.

6.2.2.5 Instrumentation Requirements

6.2.2.5.1 Reactor Containment Fan Cooler (RCFC) System

The instrumentation associated with the RCFC system provides measurements that are used to indicate, alarm, and control process variables. Analog and logic channels employed for actuation of the system are discussed in Section 7.3.

The instrumentation provided in the RCFC system is summarized as follows:

- a. The inlet and outlet air temperatures of each RCFC unit are indicated locally and in the control room to provide an indication of cooling coils performance. Extreme temperatures are alarmed in the control room for the operator's evaluation.

- b. Fan motor trip is alarmed in the control room. Motor operation is indicative of fan operation, as the fan rotor is mounted directly on the motor shaft.
- c. The degree of vibration of the fan/motor assembly is monitored and excessive vibration is alarmed in the control room.

All power-operated components including the ESW piping serving the RCFC system are capable of remote manual operation actuation by means of a signal from the control room.

A status indication of each valve and fan is provided in the control room to indicate valve position and status of fan operation.

For PWRs, Regulatory Guide 1.97 identifies containment sump water temperature and atmosphere temperature as important parameters for postaccident monitoring. Both are categorized as Type D parameters in accordance with ANS-4.5 because they are parameters that provide information to indicate the operation of individual safety systems and other systems important to safety.

Containment atmosphere temperature is to be measured in the range of 40°F to 400°F to indicate the accomplishment of cooling. The RCFC inlet and outlet temperature indicators are utilized for monitoring containment atmosphere temperature. The Design and qualification of these instruments are Category 3 as defined in Regulatory Guide 1.97. The intent of containment sump water temperature instrumentation is to provide operators verification of adequate NPSH for the RH and CS pumps during the recirculation phase of safety injection. Containment sump water temperature instrumentation, however, is not installed in the plant since other methods of ensuring NPSH have been established. These methods include conservatively calculating, with a sufficient safety margin, the available NPSH such that the containment sump water temperature is not required. Also, since the containment sump is directly connected to the RH system during recirculation, monitoring RH temperature provides an adequate alternative indication of containment cooling status. The RHR heat exchanger outlet temperature indicators are utilized as an approved alternate to monitoring containment sump temperature. The design and qualification of these instruments are Category 2 as defined in Regulatory Guide 1.97.

6.2.2.5.2 Containment Spray System

For a discussion of instrumentation requirements for the containment spray system, see Subsection 6.5.2.5.

6.2.3 Secondary Containment Functional Design

The plant design does not employ a secondary containment. This section is not applicable.

6.2.4 Containment Isolation System

6.2.4.1 Design Bases

Design of the containment isolation system follows General Design Criteria 54, 55, 56 and 57 given in 10 CFR 50, Appendix A. This is discussed in Subsections 3.1.2.5.5 through 3.1.2.5.8. In the unlikely event of an accident which releases radioactive material inside the containment, the containment atmosphere is isolated from the environment by the use of isolation valves and other barriers for all pipelines which penetrate the containment unless such lines are required for service during the accident. The function of containment

isolation is to provide an essentially leaktight barrier against the uncontrolled release of radioactivity to the environment and to limit the leakage to within the applicable requirements of 10 CFR 20, 10 CFR 50 Appendix I, 10 CFR 100, and 10 CFR 50.67 (for dose analyses performed utilizing alternative source term methods).

Adequate protection is provided for containment isolation system equipment, including valves, piping and vessels, against dynamic effects and missiles coincident with a loss-of-coolant accident and against missile damage resulting from other events requiring containment isolation. A detailed description is given in Subsections 3.5.1.2 and 3.6.2.

All valves and equipment considered to be isolation barriers are designed in accordance with Safety Category 1 criteria and are at least Quality Group B. Classification of systems and components is discussed in Section 3.2.

The Byron/Braidwood design ensures containment isolation dependability by satisfying the following requirements of NUREG-0737:

Position 1

Containment isolation systems designs shall comply with the recommendations of Standard Review Plan Section 6.2.4 (i.e., that there be diversity in the parameters sensed for the initiation of containment isolation).

The following parameters are monitored for the initiation of containment isolation:

- a. Automatic Safety Injection
- b. Containment Pressure
- c. Steamline Pressure
- d. Pressurizer Pressure

Position 2

All plant personnel shall give careful consideration to the definition of essential and nonessential systems, identify each system determined to be nonessential, describe the basis for selection of each essential system, modify their containment isolation designs accordingly, and report the results of the reevaluation to the NRC.

All systems penetrating the containment were designed to the requirements of General Design Criteria 54, 55, 56, and 57. Essential systems have been defined in Table 6.2-58.

Position 3

All nonessential systems shall be automatically isolated by the containment isolation signal.

All systems not required for hot shutdown are automatically isolated by the containment isolation signal.

Position 4

The design of control systems for automatic containment isolation valves shall be such that resetting the isolation signal will not result in the automatic reopening of containment isolation valves. Reopening of containment isolation valves shall require deliberate operation action.

The individual control circuits are designed to prevent automatic loss of containment isolation due to the resetting of the isolation signals.

Deliberate operator action is required to open the containment isolation valves after resetting the actuating signal. Each containment isolation valve must be opened individually.

Position 5

The containment setpoint pressure that initiates containment isolation for nonessential penetrations must be reduced to the minimum compatible with normal operating conditions.

The containment isolation setpoint pressure is 3.4 psig. This value is used in all analyses of the capability of the containment to withstand and contain the results of postulated line breaks. Operating plant experience indicates that use of this setpoint pressure will not result in unnecessary isolation signals. Analytical results show that the containment pressure and offsite releases will stay well below limits and that safety systems will work properly with this setpoint.

Position 6

Containment purge valves that do not satisfy the operability criteria set forth in Branch Technical Position 6-4 or the Staff Interim Position of October 23, 1979 must be sealed closed as defined in SRP 6.2.4, Item II.6.f during operational conditions 1, 2, 3, and 4. Furthermore, these valves must be verified to be closed at least every 31 days.

The containment purge valves are closed whenever the reactor is not in the cold shutdown or refueling mode. These valves are put under administrative control per ANSI N271-1976. These valves will be verified to be closed at least once every 31 days by checking position indication in the control room.

Position 7

Containment purge and vent isolation valves must close on a high radiation signal.

A high radiation signal, separate from the containment isolation signal, will close the containment purge and vent isolation valves. See Subsection 6.2.4.2.4.

Area radiation detectors RE-AR011 and RE-AR012 are interlocked with containment purge isolation valves VQ001A and B, and VQ002A and B, and containment mini-purge isolation valves VQ003, VQ004A and B, and VQ005A, B, and C. Upon detection of high radiation levels, a containment ventilation isolation signal will be initiated and the above mentioned valves that are open will be closed. It should be noted that the containment ventilation isolation signal is separate from either the Phase A or Phase B containment isolation signal as shown in Table 6.2-58.

The normal containment purge valves are locked closed by the administrative procedure of interrupting power to the valve at the circuit breaker (i.e., the circuit breaker is racked out (open)) and tagging the breaker "out of service". Inadvertent operation of the purge valves requires violation of procedures prohibiting both the operation of tagged-out equipment and the containment purge system. Tagging out at the breaker is considered equivalent to a mechanical lock because in both instances positive action is used to prevent the valve from receiving power and an administrative procedure is required to return the breaker to service. At Braidwood, valves VQ001A/B and VQ002A/B have exterior mechanical stops mounted to the valve. These valve stops are used as an additional method of locking the valves closed.

Valves VQ003, VQ004A/B, and VQ005A/B/C are equipped with an operator capable of closing the valves in 5 seconds for containment isolation (see Table 6.2-58). These 8-inch post-LOCA purge and miniflow purge valves meet the guidance of Branch Technical Position CSB 6-4.

6.2.4.1.1 Criteria for Pipeline Design

The following criteria apply to piping for which containment isolation provision is required:

- a. The design pressure of all piping and connected equipment comprising the isolated boundary is greater than the design pressure of the containment.
- b. Lines which must remain in service subsequent to certain accidents, due to safety considerations, are redundant, and each line is provided with manually actuated containment isolation provisions.

6.2.4.1.2 Criteria for Valving Design

The following criteria apply to containment isolation valving:

- a. A check valve inside the containment on incoming lines is considered to meet or exceed the criteria for a remote manual valve or an automatic valve.
- b. A locked closed valve is considered an automatic valve.
- c. Automatic trip valves are provided in those lines which must be isolated immediately following an accident, and each valve is provided with a manual switch for normal and test operations, with the position of each valve indicated in the control room.
- d. All lines on open systems for which isolation is required are provided with two barriers so that no single failure will prevent isolation (in lines where two automatic valves are provided, each valve operator is actuated by an independent signal, and each operator is also supplied from a separate emergency power supply).
- e. Air-operated isolation valves are designed to close on loss of electrical power or air supply to the valve operator.
- f. Remote manually operated valves are provided in those lines which penetrate the containment but which must remain in service subsequent to certain accidents due to safety considerations. The positions of these valves are indicated in the control room.
- g. Motor-operated valves are used where "as is" failure is required or where valve position must be changed following an accident.
- h. Check valves close by gravity or spring closure and open only when fluid pressure in the incoming line exceeds the pressure in the containment side.
- i. Isolation valves outside the containment are located as close to the containment wall as practical.

6.2.4.1.3 Criteria and Definitions for Piping Systems

Piping systems are either open or closed depending on whether they communicate with their environment. Systems which penetrate the containment are designed to minimize the possibility of leaking radioactivity to the outside environment during

normal and accident conditions. This is accomplished by the use of isolation valves.

6.2.4.1.3.1 Closed Systems

Closed systems exist either inside or outside the containment. If outside the containment, they do not communicate directly with the outside environment. A closed system outside the containment which penetrates the containment has an internal design temperature and pressure at least equal to the containment internal design temperature and pressure. This type of system can be isolated from the containment atmosphere and the reactor coolant pressure boundary. If inside the containment, a closed system does not connect directly with the containment atmosphere or with the reactor coolant pressure boundary. This type of system is isolable from the outside environment if it penetrates the containment and is connected to an open system outside the containment. These systems are designed to:

- a. withstand postulated missile impact;
- b. withstand accident temperature, pressure, and fluid velocity transients, and the resulting environment; and
- c. withstand external temperature and pressure at least equal to the containment design temperature and pressure.

6.2.4.1.3.2 Open Systems

Open systems exist either inside or outside the containment. If outside the containment, they communicate directly with the outside environment. Open systems outside the containment which penetrate the containment are isolable from the containment atmosphere and the reactor coolant pressure boundary. If inside the containment, they communicate directly with the containment atmosphere or the reactor coolant pressure boundary. Open systems inside the containment which penetrate the containment are isolable from the outside environment.

6.2.4.1.3.3 Functional Types of Penetrating Piping Systems

Based on the definitions of open and closed systems, there are four basic functional types of penetrating piping system configurations, as follows:

- a. Type 1 - two closed systems, one inside the containment and one outside the containment.
- b. Type 2 - two open systems, one inside the containment and one outside the containment.

- c. Type 3 - a closed system inside the containment and an open system outside the containment.
- d. Type 4 - an open system inside the containment and a closed system outside the containment.

All penetration piping systems fall into one or more of these functional types.

6.2.4.1.3.4 Isolation Valving

Based on the functional types of penetration piping systems of Subsection 6.2.4.1.3.3, the following valving schemes, as a minimum, are employed:

- a. System Type 1 - no isolation valves required.
- b. System Type 2 - an automatic valve inside the containment and an automatic valve outside the containment.
- c. System Type 3 - an automatic valve outside the containment or a normally closed valve under administrative control.
- d. System Type 4 - an automatic valve inside the containment.

6.2.4.2 System Design

Table 6.2-58 provides design information regarding the containment isolation provisions for fluid system lines and fluid instrument lines penetrating the containment. Column 19, labeled Isolation Signals, lists the plant protection signals which initiate closure of the automatic containment isolation valves. This issue is discussed in detail in the isolation logic section of Chapter 7.0. The extent to which containment isolation provisions of the fluid instrument lines meet the recommendations for containment penetrations for instrument lines is discussed in Chapter 7.0.

Byron Only

Test, Vent, and Drain (TVD) valves are treated as a type of containment barrier distinct from the main in-line process containment isolation valves. Surveillance requirements encompasses more than just containment isolation valves but also other containment barriers, such as blind flanges. TVD valves on containment penetration piping segments are considered containment barriers and not containment isolation valves, and therefore are still subject to the 31 day Technical Specification position verification surveillance requirement.

6.2.4.2.1 Modes of Valve Actuation

Valve actuation modes are chosen with regard to how the process line connects to the reactor coolant pressure boundary or to the containment atmosphere. Lines which connect directly to either (considered open systems inside the containment) are provided with automatically actuated valves (air or electrical) for isolation. The positions of these valves are indicated in the main control room. The valves are provided with manual override protection in the case of operator malfunction.

The control switches associated with the remote-manual operation of the containment isolation valves for the steam generator blowdown lines in penetrations P-80, 81, 82, 83, 88, 89, 90 and 91 are on the main control panel located in the main control room. Open and closed position indicating lights are also on the panel.

Lines which do not communicate directly with the reactor coolant pressure boundary or the containment atmosphere (considered closed systems inside the containment) are provided with manual actuation provisions.

All normally closed manual valves in test, vent, drain, instrument, and similar types of branch lines which serve as containment isolation barriers are under administrative controls. (Reference ANSI N271-1976, p. 2.). Test and vent connections are administratively controlled to ensure valve closure and cap reinstallation within the local leak rate test procedure, and with a checklist providing verification prior to unit restart into modes of operation when containment integrity is required.

The valves listed below are either manual or air-operated solenoid remote manual but closed during normal, shutdown, and postaccident conditions. These valves are closed and will be tagged closed under administrative controls.

Penetration Number	Valve Number	System
P-37	CV8346	RCS Fill Line
P-57	FC009, FC010	Spent Fuel Pool Cleaning Line
P-32	FC011, FC012	Spent Fuel Pool Cleaning Line
P-50, 51	SI8890A,B	Safety Injection Test Lines
P-59	SI8881	Safety Injection Test Line
P-73	SI8824	Safety Injection Test Line
P-60	SI8823	Safety Injection Test Line
P-66	SI8825	Safety Injection Test Line
P-26	SI8843	Safety Injection Test Line

6.2.4.2.2 Mechanical and Electrical Redundancy

Mechanical redundancy is provided in design to ensure that an active failure of a single valve does not prevent containment isolation. Electrical redundancy is provided in design to eliminate the dependence on a single power source to attain isolation actuation of automatic valves. Electrical cables on the separate electrical power trains for isolation valves are routed separately.

6.2.4.2.3 Qualification of Closed Systems As Isolation Barriers

Closed systems are defined and discussed in Subsection 6.2.4.1.3.1. These systems provide an isolation barrier, since their material makeup (piping, valve bodies, and components) provides physical separation between the fluid contained and the reactor coolant pressure boundary, containment atmosphere, and the outside environment. Therefore, even though they present a path for fluid flow through the confines of the containment structure, they do not provide a path for fluid flow between the environment and the reactor coolant pressure boundary, or between the environment and the containment atmosphere. The design of piping for these systems is in accordance with Subsection 6.2.4.1.1.

6.2.4.2.4 Qualification of Valves as Isolation Barriers

Valves are considered isolation barriers if they are the first or second valves on the external side of pipelines which penetrate the containment structure. Also, for certain systems, the first or second valves on the internal side of pipelines which penetrate the containment structure are considered isolation barriers. These valves prevent fluid flow:

- a. within closed systems through the containment structure,
- b. between the reactor coolant pressure boundary and the outside environment, and
- c. between the containment atmosphere and the outside environment.

The design of these valves is in accordance with Subsection 6.2.4.1.2. These valves are listed in Table 6.2-58.

6.2.4.2.5 Valve Closure Times

Valves in systems not required for safe shutdown of the plant following an accident are provided with immediate closure. Valves which must remain open during certain phases of shutdown remain open during those phases, but are provided with short closure times. Closure times vary with valve size and system function and are listed in Table 6.2-58. The containment miniflow purge

lines, which present a direct path between the containment atmosphere and the environs, are provided with closure times of less than 5 seconds. This is in accordance with the guidelines given in Branch Technical Position CSB 6-4.

6.2.4.2.6 Environmental Design

Procurement specifications for components comprising the isolation boundaries specify the applicable environmental requirements these components must meet to ensure that they are designed for the conditions (temperature, pressure, humidity and radiation) in which they will serve. The requirements are stated for both normal plant operating conditions and postulated accident conditions. Section 3.11 discusses this issue in greater detail.

6.2.4.2.7 Isolation Valve Testing

Figure 6.2-28 depicts several common methods of containment isolation valve testing used to meet the Type C leakage testing requirements of 10 CFR 50 Appendix J. Table 6.2-58 includes all the containment isolation valves tested in a like manner. The method of determining the rate of leakage may be either pressure decay using a known volume, or direct measurement by the use of a flowmeter on a makeup test system. Valves are normally tested in the proper direction; i.e., applying the gas pressure on the containment side of the valve seats. However, this method cannot always be employed because of design or operating considerations. In those cases an equivalent and sometimes conservative method of reverse direction testing is necessary. Reference Subsection 6.2.6.3 for more information.

Piping penetrations which are exempt from Type C local leakage rate testing are identified in Table 6.2-58. The following letters and evaluations provide justification for exempting these penetrations:

1. April 19, 1983 letter from F. G. Lentine to H. R. Denton
2. July 7, 1983 letter from F. G. Lentine to H. R. Denton.
3. Engineering Evaluation EC 404972 (Byron) and EC 406445 (Braidwood)

6.2.4.2.8 Exceptions to General Design Criteria 55, 56, and 57 Requirements

Lines SI06AA and SI06AB, from penetration sleeves 92 and 93 respectively (Drawing M-61, Sheet 4), are not provided with isolation valving inside the containment as required by General Design Criteria (GDC) 56. Instead, a single valve outside containment, enclosed in a controlled leakage housing, is provided. The controlled leakage housing is provided with a level switch that alarms in the main control room. The RHR system is a closed system outside containment; therefore, any through-valve leakage would be returned to the containment.

Lines RH01BA and RH01BB from penetrations 68 and 75 respectively (Drawing M-62) are not provided with isolation valving

outside the containment as required by GDC 55. No safety implications are involved because these lines tie directly into the branch lines referred to in the preceding paragraph. Figure 6.2-29, Configuration 9, shows the valving scheme used.

6.2.4.3 Design Evaluation

Figure 6.2-29 shows the sixteen different valving configurations used for containment penetration isolation. Each process line penetrating flow path can be shown schematically by one or by a combination of one or more of these configurations.

Figure 6.2-29, Configurations 1 through 7 and configurations 1A and 2A, provide isolation valving for open systems within the containment and satisfy the requirements of GDC 55 and GDC 56. By design, these schemes remain effective in providing containment isolation in the event of a single postulated pipe break or a single postulated valve failure. Between the environs and both the reactor coolant pressure boundary and the containment atmosphere there is a minimum of either two pipe boundaries, two valve boundaries, or a combination of a pipe boundary and a valve boundary.

Configurations 1A and 2A are designed to provide thermal overpressure protection for isolated penetration piping due to containment ambient temperature rise under a LOCA or MSLB condition as described in NRC GL 96-06. For the following penetrations, thermal overpressurization is mitigated by procedural controls to either drain lines or assure that isolation valves have been left open as described in References 9 and 10:

- a. PC-30: Containment Demineralized Water Supply
At Byron Station, the demineralized water system containment penetration is drained after each refueling outage. At Braidwood Station, valve 1(2)WM192A is left open during normal operation. This valve is located inside containment and provides a path from the demineralized water system, which is isolated to the containment during normal operation, to the containment atmosphere. This configuration allows pressure relief through the containment isolation check valve, 1(2)WM191, into containment and still maintains the check valve's containment isolation function.
- b. PC-32 and PC-57: Fuel Pool Cooling Return to/from Refueling Cavity
These penetrations are drained after refueling activities are completed and the reactor cavity is drained, prior to returning the plant to power operations.

Figure 6.2-29, Configurations 10 through 14, provide isolation valving for closed systems within the containment and satisfy the requirements of GDC 57. By design, the schemes remain effective in providing containment isolation in the event of a single postulated failure, either valve or pipeline. There are two boundaries, one valve and the closed system piping, between the environs and both the reactor coolant pressure boundary and the containment atmosphere.

Figure 6.2-29, Configuration 9, provides isolation valving in the residual heat removal recirculation lines. This is a closed system outside the containment which returns to the containment. The double valve provision prevents single valve failure from compromising containment isolation integrity. The valve and closed system pipeline arrangement prevents a single pipeline failure from compromising containment isolation integrity.

Figure 6.2-30 shows the instrument line penetrations. These lines are closed systems both inside and outside the containment. A single line break will not provide a path between the environs and either the reactor coolant pressure boundary or the containment atmosphere. Also refer to Subsection 7.1.2.5.

Instrument penetrations (I-1, I-2, I-3, I-4, I-5, and P-19) and the lines inside and outside containment meet the requirements of closed systems as per the standard review plan.

The leak testing test connection penetration (P-4) and the spare penetrations listed in Table 3.8-1 are closed with welded

cover plates, except three spare penetrations as discussed below. The design criteria for these cover plates are equivalent to the containment liner.

Drawing M-197-2 contains the design information for PC-4. This penetration will be used for the integrated leak rate test. The penetration is sealed off between the pipe and sleeve with a steel plate welded to both members. There is a blind flange outside containment which will seal the pipe when it is not being used for leak rate testing. Drawing M-105-3 shows the piping arrangement (PC-4 is the same as P-4).

The spare penetrations P-63, P-64, and P-74 have been modified such that a removable blind flange outside the containment serves as the containment boundary. Drawing M-197-3 contains the design information for 1PC-63, 1PC-64, and 1PC-74 in Unit 1; Drawings M-197-7 at Byron and M-197-9 at Braidwood provide the design information for 2PC-63, 2PC-64, and 2PC-74 in Unit 2. These spares are used during outages for temporary cables and hoses. (PC-63 designates 1PC-63 or 2PC-63; PC-64 designates 1PC-64 or 2PC-64 and PC-74 designates 1PC-74 or 2PC-74.)

For Unit 1, penetrations P-99, P-100, P-101, and P-102 have a closed spectacle flange outside of containment to serve as the containment boundary.

6.2.4.4 Tests and Inspections

Preoperational testing was performed to comply with the intent of 10 CFR 50 Appendix J. Penetrations valved with configurations as shown in Figure 6.2-29 have isolation valves tested for leaktight integrity prior to initial plant startup. Valving arrangements not in accordance with the configurations of Figure 6.2-29 were leaktight integrity tested in conjunction with the containment structure prior to plant startup. Inservice valve leaktight integrity testing will be done in the same manner as the preoperational testing described above. The frequency of tests will be in accordance with the requirements of 10 CFR 50, Appendix J, Option B as modified by approved exceptions in Technical Specification 5.5.16. Further discussion of tests and inspections can be found in Section 4.6 and Subsection 6.2.6.

6.2.5 Combustible Gas Control in Containment

Following a design-basis accident, hydrogen gas may be generated inside the containment by reactions such as Zirconium metal with water, corrosion of materials of construction, and radiolysis of aqueous solution in the core and sump. Studies performed by the Commission in support of the revision to 10 CFR 50.44 that eliminated the design-basis loss-of-coolant accident hydrogen release determined that hydrogen release during design basis accidents is not risk significant because it would not lead to early containment failure. Furthermore, the studies concluded that combustible gas generated from severe accidents was not risk significant for large, dry containments, such as the Byron and Braidwood containments, because of the large volumes, high

failure pressures, and likelihood of random ignition to help prevent build-up of detonable hydrogen concentrations. The containment atmosphere mixing function of the combustible gas control system required by 10 CFR 50.44 prevents local accumulation of combustible or detonable gases that could threaten containment integrity or equipment operating in a local compartment.

Technical Specification Amendment Nos. 143 and 137 for Byron Station, Units 1 and 2 and Braidwood Station, Units 1 and 2, respectively, approved the removal of the hydrogen recombiners and the containment hydrogen monitors from the Technical Specifications. However, the following commitment was made in support of these license amendments.

- Byron and Braidwood will maintain the capability of monitoring containment hydrogen for beyond design basis accidents.

The Technical Specification Amendments are based on a revision to 10 CFR 50.44, "Combustible gas control for nuclear power reactors," which eliminated the design basis LOCA hydrogen release since it was determined not to be risk significant; eliminated the requirements for hydrogen control systems to mitigate such releases; maintained the requirements for mixing the post accident containment atmosphere; and maintained the requirements for monitoring of containment atmosphere hydrogen concentration for diagnosing beyond design basis accidents.

Based on the 10 CFR 50.44 rule change, the containment atmosphere mixing and hydrogen monitoring functions are still required. However, the hydrogen control systems (i.e., hydrogen recombiners and backup hydrogen vent and purge systems) are no longer required for the Byron and Braidwood combustible gas control systems.

The containment atmosphere mixing function of the combustible gas control system required by 10 CFR 50.44 prevents local accumulation of combustible or detonable gases that could threaten containment integrity or equipment operating in a local compartment. Therefore, for large, dry PWR containments the 10 CFR 50.44 rule change eliminated the design bases loss-of-coolant accident hydrogen release and the need to calculate the design bases post accident containment hydrogen concentrations. Consequently, Regulatory Guide 1.7, "Control of Combustible Gas in Containment Following a Loss-of-Coolant Accident," Revision 2 is no longer applicable to Byron and Braidwood Stations. This Regulatory Guide provided a very conservative methodology to calculate the design basis loss-of-coolant accident hydrogen generation. This methodology assumed that during a design basis loss-of-coolant accident, the amount of hydrogen released due to the zirconium water reaction would be five times the maximum amount calculated in accordance with 10 CFR 50.46, "Acceptance criteria for emergency core cooling systems for light-water nuclear power reactors".

The adequacy of the performance of the containment atmosphere mixing function of the combustible gas control system was previously evaluated. The containment atmosphere mixing function as supported by Technical Specification 3.6.6 "Containment Spray and Cooling Systems" satisfies the combustible gas control requirements of 10 CFR 50 Appendix A General Design Criterion 41, "Containment Atmosphere Cleanup". The Containment Spray and Containment Cooling System (i.e., reactor containment fan coolers) provide the combustible gas control function via mixing the containment atmosphere during post loss-of-coolant accident conditions.

10 CFR 50.44 also requires that equipment be provided for monitoring hydrogen in containment. Equipment for monitoring hydrogen must be functional, reliable, and capable of continuously measuring the concentration of hydrogen atmosphere following a significant beyond design basis accident for accident management, including emergency planning. Based on the revision to 10 CFR 50.44 that eliminated the design basis loss-of-coolant accident hydrogen release, the hydrogen monitors are no longer required to support mitigation of design basis accidents. Consequently, the hydrogen monitors no longer meet the definition of Regulatory Guide 1.97, "Instrumentation for Light-Water-Cooled Nuclear Power Plants to Assess Plant and Environs Conditions During and Following an Accident," Category 1 instruments. Category 1 instruments are defined as applying to instrumentation designed for monitoring key variables that most directly indicate the accomplishment of a safety function for design basis accident events. Based on the revision to 10 CFR 50.44, the hydrogen monitors have been reclassified as Regulatory Guide 1.97, Category 3 instruments. Category 3 is the least stringent in that it provides for high quality commercial grade equipment that requires only offsite power. Category 3 instruments do not require seismic qualification or redundancy. The design of the hydrogen monitoring instrumentation was based on the original Regulatory Guide 1.97 Category 1 classification that exceeds the design requirements for Regulatory Guide 1.97 Category 3 instrumentation. Therefore, no changes are required for the existing instrumentation as a result of the change in Regulatory Guide 1.97 classification.

This subsection describes the various subsystems of the combustible gas control system. As discussed above, in accordance with 10 CFR 50.44 the containment atmosphere mixing and containment hydrogen monitoring functions are required. However, the hydrogen control systems (i.e., hydrogen recombiners and backup hydrogen vent and purge systems) are no longer required for the Byron and Braidwood combustible gas control systems.

6.2.5.1 Design Bases

As described in subsection 6.2.5, the hydrogen recombiners and backup hydrogen vent and purge systems are no longer required for the Byron and Braidwood combustible gas control systems. Although not required, these systems remain in place.

The following design bases were used for the combustible gas control system design:

- a. DELETED
- b. The capability to uniformly mix the containment atmosphere and prevent high concentrations of combustible gases from forming locally was considered in the system design. The natural convection processes, the mixing of containment atmosphere by containment spray system, and the

operation of the containment fan coolers assure adequate mixing.

- c. The capability to monitor combustible gas concentrations within the containment has been provided. Two systems for monitoring hydrogen concentration in the containment atmosphere are available. One is a qualified system capable of measuring the hydrogen concentrations up to 30%. The second system is a nonqualified system which is part of the hydrogen recombiners and is capable of measuring hydrogen concentrations up to 5%. This second nonqualified hydrogen monitoring system is not required.
- d. Two hydrogen recombiners, described in subsection 6.2.5.2.1, are available at each station. Cross connection piping and redundant flow paths are furnished such that either recombiner is available for either nuclear unit. Failure of any one component will not disable the redundant recombiner system. As noted above, based on a revision to 10 CFR 50.44 which eliminated the design basis LOCA hydrogen release since it was determined not to be risk significant, the hydrogen recombiners are no longer required. However, the hydrogen recombiners remain in place at this time.
- e. The location of the thermal recombiner in the auxiliary building renders it safe from any postulated dynamic effects within the containment.
- f. The combustible gas control system is designed to operate in the postaccident auxiliary building environment. Components which contact the containment atmosphere are designed to operate any time after 3 hours after a postulated LOCA.
- g. The combustible gas control system recombiner and post-LOCA purge system are located in an accessible part of the auxiliary building. These systems can be inspected or tested during normal plant operation or during shutdown conditions.
- h. During operation of the recombiners, high radiation levels near the recombiners are possible. The only local operation required is at the local control panel which is a low radiation area. Access to the recombiner itself is not required during operation.
- i. Capability is provided to purge the containment as a backup means for combustible gas control. As indicated in Branch Technical Position CSB 6-2, the purge system is not redundant, nor is it designated as Safety Category I. Each unit of both stations has a separate post-LOCA hydrogen purge system.

As noted above, based on a revision to 10 CFR 50.44 which eliminated the design basis LOCA hydrogen release since it was determined not to be risk significant, the backup hydrogen vent and purge systems are no longer required. However, the backup hydrogen vent and purge systems remain in place.

6.2.5.2 System Design

The combustible gas control system consists of four subsystems: A hydrogen recombiner; a hydrogen monitoring system; a mixing system; and a post-LOCA purge system. The design features of these four systems are described in the following subsections.

The combustible gas control system defined by the requirements of 10 CFR 50.44 consists of a hydrogen monitoring system and a mixing system. Based on a revision to 10 CFR 50.44 which eliminated the design basis LOCA hydrogen release, the hydrogen recombiners and backup hydrogen vent and purge systems are no longer required. However, the hydrogen recombiners and backup hydrogen vent and purge systems remain in place.

6.2.5.2.1 Hydrogen Recombiner System Design

The hydrogen recombiners at the Byron/Braidwood Stations can be used to help remove the hydrogen and oxygen gases that accumulate in the containment atmosphere following a loss-of-coolant accident.

The recombiner system parameters are listed in Table 6.2-59. The inlet line pipe routes the process gas from the containment, through the enclosed blower, and to the gas heater pipe which spirals around the reaction chamber. The gases are heated as they flow through the gas heater pipe, receiving its heat by radiation from electric heater elements. As the temperature of the process gas rises, the exothermic recombination of the oxygen and hydrogen gases occurs, first in the heater pipe, then within the reaction chamber. The recombined gases flow from the reaction chamber, through the gas cooler pipe and back to the containment.

The recombiner system is designed to process a minimum of 70 scfm of gas containing up to 5% hydrogen, with the balance consisting of unlimited amount of oxygen, nitrogen, or water vapor. Therefore, the system will recombine at least 3.50 scfm of hydrogen. The process is accomplished by increasing the temperature of the gas to the point where the hydrogen-oxygen reaction, $2\text{H}_2 + \text{O}_2 \rightarrow 2\text{H}_2\text{O}$, will occur spontaneously to form water vapor, using the exothermic property of the reaction to assure that it goes to completion.

After a LOCA, the recombiner could be started shortly after the containment temperature is reduced to below 225°F. All piping and wiring required for recombiner operation is permanently installed. To start the recombiner, the appropriate isolation valves are opened and the recombiner start switch is actuated.

The gas temperature is raised by the heaters until the hydrogen-oxygen reaction starts. As the gas temperature in the reaction chamber approaches the preset point of 1,325°F, the gas heater automatically reduces its power demand to maintain that preset temperature. For example, for a 4% hydrogen in air mixture and a preset reaction chamber gas temperature of 1,325°F, the heater outlet gas temperature will reduce to approximately 800°F once the reaction has begun, with the remainder of the required heat of reaction being input by the exothermic reaction itself. As the percentage of hydrogen in the air mixture is reduced, the total amount of heat given off by the

recombination reaction in the chamber reduces. The heater outlet gas temperature will rise to maintain a constant reaction chamber gas temperature of 1,325°F.

The system will operate satisfactorily with an above normal inlet process gas flow and over 5% hydrogen. The demonstration test system reported in AI-72-61, Zion Station FSAR, Appendix 6B, Amendment 25, January 1973, which has a lower flow capacity than the Byron and Braidwood systems, has operated well with all temperatures below 1,400°F and with 75 scfm of air containing 5.5% hydrogen. It also has operated well with liquid water injected into the inlet at a flow rate of >20 weight percent of the total flow. These demonstration tests have shown that the system will operate over a wide range of conditions and that the hydrogen concentration in effluent will be <0.1% over the entire range. Test results for the hydrogen recombiner are proprietary to the vendor. However, the Byron/Braidwood recombiner proposal referenced performance test results in Atomics International Report AI-75-2, "Thermal Hydrogen Recombiner Systems for Water Cooled Reactors," Revision 2, 1975. Atomics International Report AI-72-61, "Thermal Recombiner Demonstration Test," is also applicable to the Byron/Braidwood recombiners.

A single blower creates the pressure differential necessary to cause the gas flow from the containment to the recombiner system and back to the containment.

The recombination efficiency is essentially 100%. The concentration of the minimum constituent gas in the effluent is less than can be measured with equipment which has a sensitivity of 0.01% (ratio of hydrogen concentration in effluent to that in influent after steady state).

The pressure boundary and component supports of the hydrogen recombiners were constructed in accordance with the ASME Section III Class 2 requirements. The 1977 Editions plus Addenda through the Summer of 1977 are incorporated in the design.

All electrical components are Class 1E except for the hydrogen analyzer cell which is not Class 1E and the space heaters, which are non-safety-related.

The station recombiners are powered from electrical divisions E11 and E12. Redundant inlet and outlet lines are provided from each recombiner to each containment. In the event of a LOCA in either unit and a failure of a valve, or electrical division, a redundant recombiner will be available.

The hydrogen recombiner containment isolation system has inboard and outboard isolation valves close to the containment on each of the four supply and return lines for each unit. These valves have position indication in the control room and can be operated from the control room. The outboard and inboard valve on each line is powered from the same Class 1E bus. The recombiner suction and exhaust valves do not receive

containment isolation signals because isolation requirements are satisfied by the valves mentioned above. All valves associated with hydrogen recombiner containment isolation are normally closed.

The cooling air supply and exhaust points are local and this added heat load has been included in the auxiliary building HVAC system design basis. The hydrogen recombiners are located in the general area at elevation 401 feet 0 inches of the auxiliary building, which is ventilated by auxiliary building

HVAC system. The cooling fan which is an integral part of the recombiners, draws relatively cool air inside the room and exhausts the air into the general area. The auxiliary building HVAC system is safety-related and is adequate to dissipate the additional heat load from the hydrogen recombiners. Cooling air inlet and outlet structures are protected against tornados, floods, missiles, etc.

Since the hydrogen recombiner package and the separate control panel are located in the auxiliary building, adequate design provisions exist for the periodic inspection and operability testing of the system and system components. An L-shaped radiation shield is included to allow personnel to approach the recombiner and avoid unnecessary radiation exposure. This shield wall is discussed in Subsection 12.3.1.

As described earlier, the recombiner system is actuated manually from the remote control panel by energizing the interlock or prestart switches after opening the valves which isolate the recombiner system from the containment. After all interlocks are satisfied, the manual actuation of start switches would energize the blower and heater. After this, the system comes up to temperature and operates automatically.

The hydrogen recombiner system is a Quality Group B system designed in accordance with the requirements of ASME Section III, Subsection NC, Class 2 Components, and in conformance to the codes and standards listed in Table 6.2-60.

6.2.5.2.1.1 Recombiner Package Component Description

6.2.5.2.1.1.1 Blower Assembly

The gases and vapors are circulated by a blower mounted in a pressure vessel designed and fabricated in accordance with ASME Boiler and Pressure Vessel Code, Section III, Class 2 Requirements. All structural mounting and electrical and gas attachments are made to a blind flange which forms a part of the pressure vessel. Removing the flange bolts frees the remaining parts of the pressure vessel to be removed for inspection and maintenance of the blower and motor.

Motive power is provided by a 7.5-hp, totally enclosed, fan cooled (TEFC), Class H insulated, 230°F ambient rated motor. The motor will contain space heaters to keep it warm and dry. The blower impeller is mounted directly on the motor shaft. This minimum part system is expected to demonstrate very high reliability.

6.2.5.2.1.1.2 Gas Heater

The gas being heated is contained in coiled, 2-inch, Type 304 austenitic stainless steel pipe. The array of radiant heaters are individually positioned, 2 inches or more away from the

pipes and the insulation. The heaters are not muffled but are free to radiate in all directions, either directly to the pipes or to the insulation with subsequent reradiation to the pipes. The spacing of the heaters away from the process gas piping eliminates the danger of an arc damaging the pipe containing the process gas. The heaters are removable for replacement from the cold upper end without disturbing the gas piping.

This design approach has been used effectively in a number of air and sodium heating systems designed to both Section VIII and Section III of the ASME Boiler and Pressure Vessel Code. The system is readily coded, since no thin-wall tubular heater sheaths form a part of the containment boundary. The design is particularly attractive for heating reactive gases, since velocities and residence times are well controlled, with no stagnant or recirculating pockets in which the gases are delayed long enough to react. Furthermore, if, during an instability, a reaction does occur in the heater pipe, the pipe simply heats up and radiates heat during the transient to adjacent pipes and heaters. Sheathed heaters exposed directly to reactive gases have no way to dump heat, and "hot-spot" filament burnouts commonly occur in that type of design.

The heater section has 15 heater elements, each with a rating of 3.2 kW. The voltage across each element is 277 volts (480 volts connected in a "Y" arrangement), with maximum sheath temperatures of 1,600°F and heat flux of 20 W/in². Under this derated condition (from 45 W/in²), very long heater life is predicted.

6.2.5.2.1.1.3 Reaction Chamber

A uniquely constructed reaction chamber is located downstream from the heater. All materials used in its construction are Type 304 austenitic stainless steel. The gas is delivered through the heater pipe to the reaction chamber. The flow field in the reaction zone is highly turbulent, with sufficient mixing of the inlet gas with the reacting gas to bring the inlet gas temperatures rapidly to a level where virtually complete recombination occurs. The geometric configuration and volume of the reaction chamber are ample to provide gas transport times which assure that, at the process temperatures, the specified hydrogen-oxygen gas will react to virtually 100% completion. The reacted gas steam exits through a 2-inch pipe to the gas cooler.

6.2.5.2.1.1.4 Gas Cooler

The gas cooler is coiled 2-inch austenitic stainless steel pipe which ducts the reacted gas from the reaction chamber to the return outlet. A centrifugal fan forces ~3,000 cfm of air past the coil, cooling the process gas to <150°F. The heat exchange rate at design conditions is 100,000 Btu/hr.

6.2.5.2.1.2 Electrical

All wiring and terminal blocks for the heaters, blower and fan motors, and thermocouples will be protected in steel enclosures or conduits. Thermocouples are redundant at critical control points of temperature measurement and are routed separately from power wiring.

All electrical components in the system meet the requirements of ANSI C1 for NEMA 12 service.

6.2.5.2.1.3 Flowmeter

A venturi-type flowmeter is located at a flanged joint in the piping. Connections are made to a differential-pressure cell through Type 304 stainless steel tubes. An electric signal is transmitted to a flow indicator located in the control package.

6.2.5.2.1.4 Alarms and Indications

Local alarms for the hydrogen recombiner and the hydrogen analyzer are provided on the hydrogen recombiner control console annunciator. The points annunciated are as follows:

- a. return gas temperature high,
- b. reaction chamber wall temperature high,
- c. reaction chamber gas temperature low,
- d. blower off,
- e. blower temperature high,
- f. blower discharge flow low,
- g. heat exchanger off,
- h. heater outlet wall temperature high, and
- i. circuit breaker tripped.

A common hydrogen recombiner/hydrogen analyzer trouble alarm is located in the main control which also sounds for any of the above conditions.

Indications for the following hydrogen recombiner and hydrogen analyzer variables are provided locally:

- a. heater gas temperature,
- b. reaction chamber gas temperature,
- c. gas return temperature,

- d. inlet gas temperature, and
- e. H₂ concentration (0-5%).

6.2.5.2.2 Hydrogen Monitoring System Design

A hydrogen analyzer is furnished with the hydrogen recombiner to sample either the blower outlet or the recombiner outlet. Three sources of calibration gas are provided:

- a. 4% H₂ in nitrogen,
- b. 0.5% H₂ in nitrogen, and
- c. nitrogen zero gas.

A local, manual five-position selector switch energizes solenoids to admit any one of the calibrating gases or sample streams to the analyzer.

Local indication of H₂ concentration, a local H₂ concentration - high alarm light, and a local sample pressure-low alarm light are provided.

The environmental conditions for the containment atmosphere are listed in Table 3.11-2. Temperatures are given for the containment building for normal, abnormal, and accident conditions. For the accident conditions the temperatures in all areas of the containment are listed as the same. The sample conditions for the Delphi hydrogen monitor are from above saturation temperature to 300°F. The maximum sample temperature is the temperature used in the manufacturer's 100-day LOCA test.

A containment hydrogen monitoring system, independent of the hydrogen recombiners is also provided. A detailed description of this system is included in Item E.30 of Appendix E.

The requirements of NUREG-0737 Item II.F.1 Attachment 6, "Containment Hydrogen Monitor," have been satisfied as described below:

- a. The monitors are maintained in the standby mode and manually actuated from the main control room when required to operate.
- b. The monitors have a split range of 0-10% and 0-30% hydrogen concentration by volume (dry analysis) over the pressure range from -5 psig to 50 psig.
- c. The hydrogen monitors are qualified to IEEE 323-1974.

- d. Indication of hydrogen concentration is available in the main control room when the monitors are operating.
- e. The hydrogen monitors are located in the auxiliary building elevation 401 feet. Samples are piped from containment penetrations to the monitors. The accuracy of the monitors is $\pm 2.5\%$ of full scale (dry basis).

Operation of the hydrogen monitors is independent of the hydrogen recombiner and its associated hydrogen analyzer since both systems use separate piping and containment penetrations and are not dependent upon the other to operate in any way. The hydrogen monitoring system consists of two independent, physically separated and redundant subsystems. Separate piping penetrations of the containment are utilized by each train of this system. Each train's hydrogen monitor discharge containment isolation valve (PS230A/B) and one of two series inlet containment isolation valves (PS228A/229B) are powered from separate 1E sources. The second inlet containment isolation valve (PS228B/229A) is powered from the alternate power train. Isolation valves PS228B and PS229A are designed to fail open on loss of power. Thus, failure of one of the 1E electric power sources will disable only one train of the hydrogen monitoring system.

The hydrogen monitoring system was originally designed to meet the requirements of Regulatory Guide 1.97, "Instrumentation for Light-Water-Cooled Nuclear Power Plants to Assess Plant and Environs Conditions During and Following an Accident," Category 1 instruments. Regulatory Guide 1.97 Category 1 is intended for key variables that most directly indicate the accomplishment of a safety function for design basis accident events and provides for full qualification, redundancy, and continuous real-time display and requires onsite (standby) power. Based on a revision to 10 CFR 50.44 that eliminated the design basis LOCA hydrogen release, the hydrogen monitors have been reclassified as Regulatory Guide 1.97 Category 3 instruments. The design of the hydrogen monitoring instrumentation was based on the original Regulatory Guide 1.97 Category 1 classification that exceeds the design requirements for Regulatory Guide 1.97 Category 3 instrumentation. Therefore, no changes are required for the existing instrumentation as a result of the change in Regulatory Guide 1.97 classification.

The portions of the hydrogen monitoring piping system which form the containment atmosphere isolation barrier are designated Seismic Category I, Quality Group B. The remainder of the system outside the containment is Seismic Category I, Quality Group B up to the hydrogen monitoring instrumentation. Piping internal to the instrumentation is classified as ANSI B31.1. The piping from the containment to the first isolation valve is designed to the requirements of SRP 3.6.2.

A sample of the containment atmosphere is taken at or near one of the containment penetrations and another approximately 180 degrees away on the other side of the containment (approximately

135 degrees away for Byron Unit 2 only). The samples taken are representative of the containment atmosphere due to the mixing system effects.

The mechanical piping penetrations used for the hydrogen monitoring system at Byron and Braidwood are as follows:

Penetrations	Byron	Braidwood
1PC-12, 2PC-12	Train A discg.	spare
1PC-31, 2PC-31	Train B discg.	spare
1PC-36, 2PC-36	Train B suction	Train B suction/discg.
1PC-45, 2PC-45	Train A suction	Train A suction/discg.

Additional information concerning the mechanical penetrations's elevations and azimuths are listed in Table 3.8-1.

6.2.5.2.3 Containment Atmosphere Mixing System Design

The mixing subsystem satisfies the requirements of 10 CFR 50.44. The function of the mixing subsystem is to prevent local accumulation of combustible or detonable gases that could threaten containment integrity or equipment operating in a local compartment. The mixing is achieved by natural convection processes, reactor containment fan cooler operation, and the containment spray system.

Natural convection occurs as a result of the temperature difference between the bulk gas space in the vessel and the containment wall. The natural convection action is enhanced by the momentum of steam emitted from the point of the break.

The operation of the containment spray system following the accident will result in the creation of an extremely turbulent atmosphere within the containment, as demonstrated in the Zion Station full-flow containment spray system test. The containment spray system is discussed in Subsection 6.5.2.

Mixing of the containment atmosphere to assure that there will be no "pocketing" of large hydrogen concentrations will be accomplished by the reactor containment fan coolers (RCFC), an engineered safety feature described in Subsection 6.2.2.

The operation of the recombiner system is not dependent on the operation of any engineered safety features other than the reactor containment fan coolers. Four coolers (two required for both normal and postaccident conditions) each supplying 94,000 cfm (normal operation) or 59,000 cfm (postaccident operation) are provided for each containment. The RCFC fans discharge this air through concrete ducts to the lower elevation.

6.2.5.2.4 Post-LOCA Purge System Design

The post-LOCA purge system is described in Subsection 9.4.9.3. The schematic diagram of the system is shown in Drawings M-105 and M-106. Equipment parameters are given in Table 6.2-61.

6.2.5.3 Design Evaluation

As discussed in section 6.2.5, the combustible gas control system as defined by the requirements of 10 CFR 50.44 consists of a hydrogen monitoring system and a mixing system. Based on the revision to 10 CFR 50.44 which eliminated the design basis LOCA hydrogen release, the hydrogen recombiners and backup hydrogen vent and purge systems are no longer required. Studies performed by the Commission in support of the 10 CFR 50.44 rule change, determined that hydrogen release during design basis accidents is not risk significant and would not lead to early containment failure. The mixing function prevents local accumulation of combustible or detonable gases that could threaten containment integrity or equipment operating in a local compartment. The studies performed by the Commission demonstrate that containment atmosphere mixing function satisfies the 10 CFR 50 Appendix A Criteria 41 requirement to control the concentration of hydrogen in the containment atmosphere following postulated accidents as required to assure that containment integrity is maintained. The hydrogen monitoring system is required to diagnose beyond design basis accidents.

THIS PAGE WAS INTENTIONALLY DELETED

THIS PAGE WAS INTENTIONALLY DELETED

THIS PAGE WAS INTENTIONALLY DELETED

THIS PAGE WAS INTENTIONALLY DELETED

THIS PAGE WAS INTENTIONALLY DELETED

THIS PAGE WAS INTENTIONALLY DELETED

6.2.5.4 Testing and Inspection

The hydrogen recombiners have been shop tested to assure proper operation of the heaters, fans, and other components. Because their operation relies on a simple and well-proven principle, testing with hydrogen has not been done. The (hydrogen recombiners) for Byron/Braidwood do not have or require a leakage limit. The recombiners have undergone pneumatic testing at other stations and have exhibited virtually no leakage. Since the recombiners are protected from overpressurization during an accident by the various containment protection and reactor protection systems,

no additional protection is deemed necessary. Prior to shipment, the units for Byron/Braidwood were pneumatically tested.

Each active component of the combustible gas control system is testable during normal reactor power operation.

The hydrogen recombiner system and the containment purge system are tested periodically to assure that they will operate correctly. Preoperational tests of the combustible gas control system are conducted during the final stages of plant construction prior to initial startup.

6.2.5.5 Instrumentation Requirements

A description of the controls provided for the post-LOCA purge system is given in Subsection 9.4.9.3.

A panel containing all operating controls for each of two redundant hydrogen recombiners will be located outside of the containment. The controls include adequate automatic controls and alarms to allow the unattended operation of the recombiners. These controls include an automatic temperature controller for the regulation of the air temperature in the recombiner chamber and interlocks for the recombiner fans which cut off power to the thermal element in the event that power to the fans is interrupted.

All controls for the hydrogen recombiners are classified as Safety Category I.

6.2.5.6 Materials

The material for the high-temperature recombiner components is Type 304 austenitic stainless steel meeting the ASME Boiler and Pressure Vessel Code requirements for Section III, Class 2 components. This material provides the requisite structural integrity and corrosion resistance for the service environment and operating conditions.

The skid and heater enclosure structure are made of ASTM A-36 structural steel. The external surfaces are painted with a rust-inhibiting primer paint. Heat from the "trickle heater" will keep the internal surfaces dry, thereby inhibiting corrosion.

6.2.6 Containment Leakage Testing

The proposed containment leakage testing program is summarized below. The program complies with the requirements of the General Design Criteria and Appendix J of 10 CFR 50. The tests described in the following subsections are for preoperational and periodic testing of the reactor containment isolation barriers.

Byron and Braidwood have been approved to implement 10 CFR 50.69, "Risk-informed categorization and treatment of structures,"

systems, and components for nuclear power plants." This regulation provides an alternative approach for establishing requirements for treatment of structures, systems, and components (SSCs) using a risk-informed method of categorizing SSCs according to their safety significance. Specifically, for SSCs categorized as low safety significant, alternate treatment requirements may be implemented rather than treatments chosen by the 10 CFR 50 Appendix J program. Refer to Section 3.2.3 for further information.

6.2.6.1 Containment Integrated Leakage Rate Test

The Type A test is performed using the Absolute Method. The preoperational Type A test was performed at two pressures: greater than or equal to P_a , 44.4 psig, and P_t , 22.2 psig for the full pressure and reduced pressure test, respectively. Type A tests are performed at a nominal P_a and at a frequency ranging from once every 48 months to once every 10 years based on Type A test performance history or as modified by approved exceptions in Technical Specification 5.5.16. The maximum allowable leakage rate L_a at pressure P_a is 0.20% per day for the full pressure test.

The Type A test is performed in accordance with the provisions of ANSI N56.8-1994. The duration of preoperational Type A test is 24 hours, during which data is collected in order to justify a shorter duration test. Paragraph 7.6 states that, "if it can be demonstrated...that the leakage rate can be accurately determined during a shorter test period, the agreed upon shorter period may be used."

Test, vent, and drain (TVD) connections used to complete Type A, B, and C containment testing are under administrative control as per ANSI N271-1976, Section 2. Connections are closed and signed off and under periodic surveillance with respect to minimizing the exposure of operating personnel to as low as reasonably achievable.

6.2.6.1.1 Containment Inspection and Repair

A general visual inspection of the accessible interior and exterior surfaces of the containment structures and components shall be performed prior to any Type A test and during two other refueling outages before the next Type A test (if the interval for the Type A test has been extended to 10 years) or during three other refueling outages before the next Type A test (if the interval has been extended to 15 years) to uncover any evidence of structural deterioration which may affect either the containment structural integrity or leak tightness. If there is evidence of structural deterioration, a Type A test shall not be performed until corrective action is taken in accordance with acceptable procedures, nondestructive tests and inspections.

Such structural deterioration and corrective actions taken shall be included as part of the test record.

6.2.6.1.2 Preoperational Tests

A structural integrity test shall precede the preoperational Type A test. A containment isolation system functional test and Type B and Type C leakage tests may be completed prior to the preoperational Type A test. In the event a Type B or Type C test is not completed prior to the preoperational Type A tests, any Type B and Type C penetration path test leakage not accounted for in the Type A test shall be added to the measured overall integrated leakage rate L_{am} . The reason for delaying the

performance of Type B and C tests shall be documented.

The venting and draining of systems complies with the "Leakage Testing Requirements" of 10 CFR 50, Appendix J. Any exceptions to this are identified in formal written correspondence. The RHR system was not vented or drained during initial Type A tests or periodic Type A tests. Systems that are closed inside containment were not vented or drained. The RCS was vented to the containment.

The hydrogen recombiner system is designed with containment isolation valves both inside and outside the containment wall for each piping penetration. A Type C local leakage rate test is performed on all containment isolation valves of this system. Testing of the hydrogen recombiner system during the integrated leak rate test is done in the same manner as any other "OPEN" system and complies with Appendix J of 10 CFR 50.

6.2.6.1.3 Containment Isolation Valve Closure

Closure of containment isolation valves for the Type A test shall be accomplished by normal operation and without any preliminary exercising or adjustments (e.g., no tightening of remote operated valves after closure). In the event a valve cannot be closed by normal methods, the method used shall be documented and local leak rate tests performed following installation and/or closure by normal means.

6.2.6.1.4 System Venting and Draining

Those portions of the fluid systems that are part of the reactor containment boundary that may be open directly to the containment or outside atmosphere under postaccident conditions shall be opened or vented to the appropriate atmosphere during the test. This includes portions of systems inside or outside containment that penetrate the containment and may break as a result of a loss of coolant accident. Systems that are required to maintain the plant in a safe condition during the test shall be operable in their normal mode and need not be vented. Systems that are normally filled with water and operating under postaccident conditions, such as the containment heat removal system, need not be vented or drained. Systems used for proper conduct of the test need not be vented or drained, but they must be Type C tested and the leakage for the penetration path added to L_{am} unless the system is specifically designed to survive the accident. If a system that may not survive an accident condition cannot be vented and/or drained, the Type C test leakage rate for the penetration path shall be added to L_{am} . For planning and scheduling purposes or ALARA considerations, pathways that are Type B or C tested within the previous 24 calendar months need not be vented or drained during the Type A test. The Type B or C leakage must be added to L_{am} .

6.2.6.1.5 Pressure Stabilization Period

To prevent outgasing from concrete or equipment within containment that may affect the validity of test results, the containment internal environment shall be at a pressure less than 85% P_{ac} for at least 24 hours prior to commencing the Type A test

at P_{ac} and shall stabilize for a period of not less than 4 hours after test pressure P_{ac} is reached.

6.2.6.1.6 Containment Atmosphere Stabilization

Upon completion of primary containment pressurization to the test pressure, the primary containment air mass shall be allowed to stabilize prior to the start of the Type A test. Primary containment atmosphere stabilization shall demonstrate that the containment dry air mass is stable. The criteria for containment atmosphere stabilization are listed in ANSI/ANS 56.8-1994.

6.2.6.1.7 Type A Test Frequency

Type A tests are performed at a frequency ranging from once every 48 months to once every 10 years based on Type A test performance history (Reference 31) as modified by approved exceptions in Technical Specification 5.5.16.

6.2.6.1.8 Test Duration

After the containment atmosphere has stabilized, the integrated leakage rate test period begins. The duration of the test period shall be sufficient to enable adequate data to be accumulated and statistically analyzed so that a leakage rate and upper confidence limit can be accurately determined. A Type A test shall last a minimum of 6 hours after stabilization and shall have a total of not less than 30 sets of data points at approximately equal time intervals. A plot of containment air absolute pressure versus time shall also be made.

6.2.6.1.9 Calibration

Calibration data provided for Type A test instrumentation shall include information concerning the error associated with measurement of change by the individual measurement system. Instrumentation used for Type A containment integrated leakage rate tests shall be individually calibrated or checked as applicable no more than 6 months prior to the start of the Type A test. Primary test instrument calibration regarding accuracy shall be traceable to the National Institute of Standards and Technology. Instrumentation repeatability shall be certified by the supplier.

6.2.6.1.10 Acceptance Criteria

The measured as-found leakage rate at the upper 95% confidence limit, which includes appropriate consideration for random measurement errors, shall be below L_a . Depending on the sensitivity and repeatability of the instrumentation, the duration of a Type A test may have to be extended in order to achieve this degree of statistical confidence. The measured containment leakage rate shall be obtained by a linear regression analysis of the test data using the method of least squares. If the

leakage rate exceeds the acceptance criterion, a Type A test need not be repeated provided major leakage paths are isolated and local leakage rate measurements are conducted before and after repair of local penetrations so isolated. Test results shall include both the prerepair and postrepair result values, i.e., two Type A values are reported; as follows:

- a. Prerepaired local leak rate test results, and
- b. Postrepaired test results.

Records of the corrective action shall be documented.

The measured as-left leakage rate at the upper 95% confidence limit plus the as-left minimum pathway leak rate (MNPLR) of all leakage paths isolated during the performance of the Type A test shall be below 75% L_a .

6.2.6.1.11 Verification Tests

A verification test shall be performed following each Type A test. The verification test provides a method for assuring that systematic error or bias is given adequate consideration. During the verification test, containment pressure may not decrease to less than 0.96 P_a . The test shall be performed using the calibrated leak method. In this method, a calibrated leak is intentionally superimposed on the existing leaks in the containment system. Acceptability is demonstrated if:

$$(L_0 + L_{am} - 0.25 L_a) \leq L_c \leq (L_0 + L_{am} + 0.25 L_a)$$

The superimposed leakage rate (L_0) shall be between 75% and 125% of L_a . L_c is the composite leakage rate measured using the Type A test instrumentation after L_0 is superimposed.

6.2.6.2 Containment Penetration Leakage Rate Test

Type B tests are performed at a test pressure of P_a or greater and at a frequency ranging from once every 30 months to once every 120 months, based on Type B test performance history. Type C tests are performed at a test pressure of P_a or greater and at a frequency ranging from once every 30 months to once every 60 months, based on Type C test performance history (Ref. 31). When a higher differential pressure results in increased sealing, such as in the case of a closed check valve, the differential pressure in a Type B or C test shall not exceed 1.1 P_a . Air or nitrogen shall be the test media. When the pressure decay method of local leak rate testing is employed, a minimum of 15 minutes

duration is used. The majority of the Type B and C tests will be performed using a direct measurement system, for example, a flow meter. An appropriate method to demonstrate stabilized conditions is used to determine the duration of this type of test.

Containment penetrations whose design incorporates resilient seals, gaskets, or sealant compounds receive preoperational and periodic tests in accordance with 10 CFR 50 Appendix J.

The following penetrations will be tested:

- a. equipment access hatch,
- b. the two personnel access hatches,
- c. fuel transfer penetration (Figure 6.2-37),
- d. electrical penetrations (Figure 3.8-43), and
- e. spare containment penetrations PC-63, PC-64, and PC-74.

Containment penetrations are anchor points in their respective systems and have been designed to 1974 ASME III, Summer 1975 Addenda.

The following containment piping penetrations are fitted with expansion bellows:

1. fuel transfer tube penetration sleeve, and
2. recirculation sump effluent pipe i.e., closure joint between the process pipe and guard pipe.

There are three expansion bellows in the penetration sleeve of the fuel transfer tube and one bellow attached to the penetration sleeve of each recirculation sump effluent pipe. The bellows on the recirculation sump effluent pipes are flood seals and are not required to maintain containment integrity.

Test methods used in determining the leakage through the penetrations are given in the following. The physical descriptions of the penetrations are given in Subsection 3.8.2.1.

a. Equipment Access Hatch

The equipment access hatch has been furnished with a double-gasketed flange and bolted dish door (Figure 3.8-38). Provisions are made to pressurize the space between the double gaskets of the door flanges and the weld seam channels at the liner joint, hatch flange, and dished door.

b. Personnel Access Hatch

There are two personnel locks. One penetrates the dished door of the equipment hatch, used for access to the containment building. The second, which penetrates the containment on the side opposite the equipment hatch at grade level (Figure 3.8-39), is used as an emergency escape route, an alternate containment access at power, and as routine access for personnel and equipment into and out of the containment building during cold shutdown, refueling mode, and when the reactor is defueled. An access facility is located next to the containment building emergency hatch entrance to facilitate entry of materials, equipment, and personnel into the containment while maintaining radwaste and contamination control. Both personnel locks are double-door, mechanically latched, welded steel assemblies. The space between the doors can be pressurized to peak containment pressure, P_a , through test connections. The airlocks shall be tested at 30-month intervals at an internal pressure not less than P_a . The Type B test for the airlock door seals shall be performed at a pressure between 3 and 12 psig either as described in Section III.D.2.bii of 10 CFR 50, Appendix J or by installing a continuous pressurization source to the airlock door seals that will be monitored by a flowmeter and alarm.

Stabilization criteria for testing the airlocks shall be "less than 1 psig change in the test volume pressure in the last 15 minutes and less than 20% change in the flowrate reading in the last 5 minutes" or "after monitoring the flow rate at test pressure for a minimum of 4 hours." Provisions made for leak testing of the door seals consist of taps, which are threaded to allow capping during operation and connection for test purposes, and a volume between the gaskets for test pressurization. A flanged pipe is provided through the exterior bulkhead of the lock for leak testing of the entire lock. The flanges of this pipe are detailed to provide for a bolted connection of a cap during operation or another flanged pipe for test purposes. Leakage from each door can be monitored and the total leakage rate can be measured at P_a .

The interior lock door is restrained during lock leak testing by means of horizontal beams which span the door frame inside the lock. They are bolted to the door adjacent to the door/bulkhead mating surface. There are five of these beams located at equal spacing vertically and symmetrically about the door midheight. The only penetrations through the personnel air lock are two 2-inch diameter pipes through which air sampling is taken from and returned to the containment. At Byron, the air sampling units have been removed and the two 2-inch diameter pipes are capped.

c. Fuel Transfer Penetration

The penetration consists of a 20-inch pipe inside a 24-inch sleeve. The inner pipe will be fitted with a double-gasketed blind flange in the refueling canal. A seal plate will be welded to the containment liner and also the inside tube. This seal plate and the blind flange act as the containment boundary. In order to leak test the blind flange, provisions will be made to pressurize the space between the double gaskets of the blind flange. The integrity of the seal plate and its welds to the containment liner and fuel transfer tube is verified during the Type A test.

The fuel transfer tube sleeve bellows are tested in accordance with Type B test methods allowed by 10 CFR 50 Appendix J.

d. Electrical Penetrations

Electrical penetrations are tested individually or in groups in accordance with Type B test methods allowed by 10 CFR 50 Appendix J.

A nitrogen supply system is used to provide continuous pressurization between the closure flanges of all containment wall electrical penetrations, with the exception of 1CQ01E, 1CQ02E, 2CQ01E, 2CQ02E and various spare penetrations. This system supplies a clean, dry cover gas for the penetrations and is used for periodic leakage monitoring during periods between Type B tests. Operation of the system is not required to maintain the containment integrity. The electrical penetrations installed on the equipment access hatch (discussed in Subsection 6.2.6.2.a) and on the personnel access hatch (discussed in Subsection 6.2.6.2.b) are not provided with a nitrogen supply system. These electrical penetrations provide Class Non-1E power feeds to the electrical circuits associated with the hatches.

Electrical penetrations 1CQ01E and 2CQ01E are installed on the equipment/personnel access hatch, and electrical penetrations 1CQ02E and 2CQ02E are installed on the emergency escape hatch. These penetrations feed the Class Non-1E electrical circuits associated with the hatches.

The acceptance criteria for preoperational and periodic testing are in compliance with Appendix J of 10 CFR 50.

e. Spare Containment Penetrations (PC-63, PC-64, and PC-74)

These penetrations consist of a 16-inch-diameter sleeve with a welded neck flange and a blind flange on the outside of the containment. The blind flange is fitted with a double gasket with provisions for pressurizing the space between the gaskets. The penetrations are tested individually in accordance with Type B test methods stated in 10 CFR 50 Appendix J.

6.2.6.3 Containment Isolation Valve Leakage Rate Test

Containment penetrations with isolation valving as shown in Figure 6.2-28 are provided with the leak test provisions shown to satisfy the Type C leak test requirements.

Isolation valves outside containment are positioned as close as possible to the containment boundary.

The acceptance criteria for preoperational and periodic testing are in compliance with Appendix J of 10 CFR 50.

Some valves are Type C tested in the reverse-direction as per Appendix J to 10 CFR 50. Specifically, the following valves can be tested in the reverse-direction, which is clearly equivalent or more conservative than the forward direction: butterfly, plug, diaphragm, and globe valves.

Butterfly and diaphragm valves have one sealing surface. Plug valves have a common sealing surface from both directions. In some instances, globe valves may be pressurized on the downstream side of the valve including packing leakage.

The capability currently exists to leak test the purge/vent containment isolation valves during operational Modes 1 through 4 of plant operation as listed in BTP CSB-6-4. The overall surveillance program conforms to the periodic retest scheduled in accordance with Appendix J to 10 CFR 50. During each periodic retest, attention is given to active and passive purge/vent systems.

6.2.6.4 Scheduling and Reporting of Periodic Tests

The periodic test schedule is referenced in the Technical Specifications.

6.2.6.5 Special Testing Requirements

There are no special requirements for maximum allowable leakage rate for inleakage. The design conditions for the containment (-0.1 to 1.0 psig) allow for a slight positive internal pressure.

The design positive internal pressure would eliminate the necessity for establishing a maximum allowable inleakage.

6.2.7 References

1. F. M. Burdelon and E. T. Murphy, "Containment Pressure Analysis Code (COCO)," WCAP-8327 (Proprietary) and WCAP-8326 (Non-Proprietary), 1974.
2. T. Hsieh, R. T. Barlow, and H. V. Julian, "Environmental Qualification - Instrument Transmitter Temperature Transient Analysis", WCAP 8936, February 1977.
3. Takashi Tagami, "Interim Report on Safety Assessments and Facilities, Establishment Project in Japan for Period Ending June, 1965 (No. 1)".
4. E. W. Ranz and W. R. Marshall, Jr., "Evaporation for Drops," Chemical Engineering Progress, 48141-146, March 1952.
5. L. F. Parsly, "Spray Tests at the Nuclear Safety Pilot Plant," in: "Nuclear Safety Program Annual Progress Report for Period Ending December 31, 1970", ORNL 4647, p.82, Oak Ridge National Laboratory, 1971.
6. Westinghouse Electric Corporation, "Pipe Breaks for the LOCA Analysis of the Westinghouse Primary Coolant Loop," WCAP 8082-P-A, June 1973 (Proprietary) and WCAP 8172-A, January 1975 (Non-Proprietary).

7. R. M. Shepard et al., "Westinghouse Mass and Energy Release Data for Containment Design," WCAP-8264-P-A, June 1975 (Proprietary and WCAP-8312-A, Revision June 1975 (Non-Proprietary)).
8. R. Salvatori, "Ice-Condenser Containment Pressure Transient Analysis Methods," WCAP-8077, March 1973 (Proprietary), and WCAP-8078, March 1973 (Non-Proprietary).
9. Letter from R.M. Krich (Commonwealth Edison Company) to U.S. NRC, "Supplemental Information Regarding a Request for Additional Information Related to NRC Generic Letter 96-06, "Assurance of Equipment Operability and Containment Integrity During Design-Basis Accident Conditions," dated October 27, 1999.
10. Letter from U.S. NRC to C.M. Crane (Exelon Generation Company, LLC), "Byron Station, Units 1 and 2, and Braidwood Station, Units 1 and 2, Generic Letter 96-06, 'Assurance of Equipment Operability and Containment Integrity During Design-Basis Accident Conditions," dated February 24, 2004.
11. (Deleted)
12. I. M. Bordelon et al., "Westinghouse Emergency Core Cooling System Evaluation Model - Summary," WCAP-8339, June 1974.
13. J. J. DiNunno et al., "Calculation of Distance Factors for Power and Test Reactor Sites," TID-14844, March 1962.
14. W. B. Cottrell, "ORNL Nuclear Safety Research and Development Program Bi-Monthly Report for July - August 1968," ORNL-TM-2368, November 1968.
15. W. B. Cottrell, "ORNL Nuclear Safety Research and Development Program Bi-Monthly Report for September - October 1968," ORNL-TM-2425, p. 53, January 1969.
16. RELAP4/MOD5, A Computer Program for Transient Thermal Hydraulic Analysis of Nuclear Reactors and Related Systems, User's Manual Idaho National Engineering Laboratory, ANCR-NUREG-1335, September 1976.
17. I.E. Idel'chik, "Handbook of Hydraulic Resistance, Coefficients of Local Resistance and of Friction," AEC-TR-6630, 1960.
18. Letter to Mr. D. B. Vassallo, Chief, Light Water Reactors Project Branch 6, USNRC From Mr. C. Eicheldinger, Manager, Nuclear Safety, Westinghouse Electric Corporation, (NS CE-992) Dated March 17, 1976.

B/B-UFSAR

19. Letter to Mr. D. B. Vassallo, Chief, Light Water Reactors Project Branch 6, USNRC From Mr. C. Eicheldinger, Manager, Nuclear Safety, Westinghouse Electric Corporation, (NS CE-692) Dated July 10, 1975.
20. Letter to Mr. D. B. Vassallo, Chief, Light Water Reactors Project Branch 6, USNRC From Mr. C. Eicheldinger, Manager, Nuclear Safety, Westinghouse Electric Corporation, (NS CE-1021) Dated April 7, 1976.
21. Letter to Mr. J. F. Stolz, Chief, Light Water Reactors Project Branch 6, USNRC From Mr. C. Eicheldinger, Manager, Nuclear Safety, Westinghouse Electric Corporation, (NS CE-1183) Dated August 27, 1976.
22. Commonwealth Edison Letter RS-00-38, Attachment E, "Power Uprate Licensing Report for Byron Station and Braidwood Station," July 5, 2000.
23. (Deleted)
24. (Deleted)
25. (Deleted)
26. (Deleted)
27. (Deleted)
28. Shapiro, H. A., "The Dynamics and Thermodynamics of Compressible Fluid Flow," Volume 1, p. 85.
29. 1967 ASME Steam Tables, p. 301.
30. Letter from John F. Stolz to Thomas M. Anderson, March 27, 1980.

31. Nuclear Energy Institute, "Industry Guideline for Implementing Performance-Based Option of 10 CFR 50, Appendix J," NEI 94-01, July 1995.
32. Burnett, T. W. T., et al, "LOFTRAN Code Description," WCAP-7907-P-A (Proprietary), WCAP-7907-A (Nonproprietary), April 1984.
33. Commonwealth Edison NFS Calculation PSA-B-96-08, "Thermal Hydraulic Behavior of RCFC Coils During LOCA for Byron/Braidwood."
34. Commonwealth Edison Calculation BRW-97-0395-M, "Evaluation of the Effects Related to GL 96-06 for Piping Subsystem 1SX09."
35. DELETED
36. DELETED
37. "Westinghouse LOCA Mass and Energy Release Model for Containment Design - March 1979 Version," WCAP-10325-P-A, May 1983 (Proprietary), WCAP-10326-A (Non-Proprietary).
38. Docket No. 50-315, "Amendment No. 126, Facility Operating License No. DPR-58 (TAC No. 7106), for D. C. Cook Nuclear Plant Unit 1," June 9, 1989.
39. EPRI 294-2, "Mixing of Emergency Core Cooling Water with Steam; 1/3-Scale Test and Summary," (WCAP-8423), Final Report, June 1975.
40. ANSI/ANS-5.1 1979, "American National Standard for Decay Heat Power in Light Water Reactors," August 1979.
41. Letter from R. Assa (NRC) to I. Johnson (Commonwealth Edison), "Safety Evaluation (SE) Regarding Leak-Before-Break Analysis, Byron Stations Units 1 and 2, and Braidwood Station Units 1 and 2, (TAC Nos, M95342, M95343, M95344, and M95345)," October 25, 1996.
42. Letter from A. Hsia (NRC) to T. Kovach (Commonwealth Edison), Safety Evaluation of Leak-Before-Break Methodology Applicable to Accumulator Piping and Reactor Coolant Bypass Piping (TAC Nos, 73306, 73307, 73308, and 73309), April 19, 1991.
43. NRR Division of Component Integrity Response, "Leak-Before-Break (LBB) Knowledge Management Document", TAC No. MD3570 (ADAMS: TAC No. ML092430585), May 29, 2007.
44. Design Analysis No. CN-CRA-00-8, "Byron/Braidwood 1&2 Update Project-Short Term LOCA Mass & Energy Releases and Subcompartment Pressurization."

TABLE 6.2-1

UNIT 1 CONTAINMENT PEAK PRESSURE AND TEMPERATURE

BREAK	PEAK PRESSURE (psig)	AVAIL-ABLE MARGIN (psi)	PEAK TEMPER-ATURE (°F)
<u>Primary Side Ruptures</u>			
Double-ended pump suction - Max SI (Note 1)	40.85	9.15	261.56
Double-ended pump suction - Min SI	42.08	7.92	262.6
Double-ended hot leg - Min SI	42.10	7.90	263.5
<u>Secondary Side Breaks</u>			
<u>Limiting Pressure Cases for Composite Curve (Note 2)</u>			
Full double-ended break - 95.1% power (RCFC train failure)	38.8	11.2	N/A
Full double-ended break - 28.0% power (RCFC train failure)	38.8	11.2	N/A
Full double-ended break - 95.1% power (feedwater isolation valve failure)	39.3	10.7	N/A
Full double-ended break - 0% power (RCFC train failure)	37.7	12.3	N/A
Full double-ended break - 95.1% power (loss of offsite power with emergency diesel generator failure)	32.4	17.6	N/A
Full double-ended break - 28.0% power (loss of offsite power with emergency diesel generator failure)	33.0	17.0	N/A
0.87-ft ² split break - 28.0% power (loss of offsite power with emergency diesel generator failure)	29.2	20.8	N/A
<u>Limiting Pressure Cases (No LOOP) for UHS Temperature Increase Analysis (Note 4)</u>			
Full double-ended break - 0% power (RCFC train failure)	32.23	17.77	N/A

TABLE 6.2-1 (Cont'd)

UNIT 1 CONTAINMENT PEAK PRESSURE AND TEMPERATURE

BREAK	PEAK PRESSURE (psig)	AVAIL- ABLE MARGIN (psi)	PEAK TEMPER- ATURE (°F)
Full double-ended break - 100% power (MSIV failure)	32.58	17.42	N/A
Full double-ended break - 30% power (MSIV failure)	32.75	17.25	N/A
Full double-ended break - 100% power (FIV failure)	32.12	17.88	N/A
0.96 ft ² split break - 70% power (MSIV failure)	33.77	16.23	N/A
0.90 ft ² split break - 30% power (MSIV failure)	34.48	15.52	N/A
<u>Secondary Side Breaks</u>			
<u>Limiting Temperature Cases for Composite Curve (Note 3)</u>			
Full double-ended break - 95.1% power (loss of offsite power with FIV failure)	N/A	N/A	284
1.0-ft ² double-ended break - 100% power (loss of offsite power with MSIV failure)	N/A	N/A	334
1.0-ft ² double-ended break - 100% power (MSIV failure)	N/A	N/A	327
0.96-ft ² split break - 95.1% power (loss of offsite power with emergency diesel generator failure)	N/A	N/A	327
1.0-ft ² split break - 100% power (RCFC train failure)	N/A	N/A	318
0.96-ft ² split break - 95.1% power (RCFC train failure)	N/A	N/A	316
0.93-ft ² split break - 65.3% power (RCFC train failure)	N/A	N/A	313

TABLE 6.2-1 (Cont'd)

UNIT 1 CONTAINMENT PEAK PRESSURE AND TEMPERATURE

<u>BREAK</u>	<u>PEAK PRESSURE (psig)</u>	<u>AVAIL- ABLE MARGIN (psi)</u>	<u>PEAK TEMPER- ATURE (°F)</u>
1.0-ft ² double-ended break - 95.1% power (RCFC train failure)	N/A	N/A	307
1.0-ft ² double-ended break - 65.3% power (RCFC train failure)	N/A	N/A	305
1.0-ft ² double-ended break - 28.0% power (RCFC train failure)	N/A	N/A	302
1.0-ft ² double-ended break - 0% power (RCFC train failure)	N/A	N/A	299
Full double-ended break - 28.0% power (RCFC train failure)	N/A	N/A	278
Full double-ended break - 0% power (RCFC train failure)	N/A	N/A	255
Full double-ended break - 95.1% power (loss of offsite power with emergency diesel generator failure)	N/A	N/A	284
Full double-ended break - 28.0% power (loss of offsite power with emergency diesel generator failure)	N/A	N/A	278
0.87-ft ² split break - 28.0% power (loss of offsite power with emergency diesel generator failure)	N/A	N/A	318
<u>Limiting Temperature Cases (LOOP)</u>			
<u>for UHS Temperature Increase</u>			
<u>Analysis (Note 5)</u>			
1.00 ft ² split break - 100% power (MSIV failure)	N/A	N/A	329
Small double-ended break - 100% power (MSIV failure)	N/A	N/A	328.2
Small double-ended break - 70% power (MSIV failure)	N/A	N/A	327
Small double-ended break - 70% power (RCFC failure)	N/A	N/A	310.3

TABLE 6.2-1 (Cont'd)

BREAK	PEAK PRESSURE (psig)	AVAIL- ABLE MARGIN (psi)	PEAK TEMPER- ATURE (°F)
Full double-ended break - 100% power (MSIV failure)	N/A	N/A	248
Full double-ended break - 100% power (RCFC train failure)	N/A	N/A	237.2
0.64 ft ² split break - 0% power (MSIV failure)	N/A	N/A	293.6

Note 1 This case was not re-analyzed for the MUR uprate of the UHS temperature increase analyses.

Note 2 For these cases, 130°F initial containment temperature and 15.7 psia initial containment pressure were assumed. See Figure 6.2-13 for a composite pressure curve.

Note 3 For these cases, 120°F initial containment temperature and 14.6 psia initial containment pressure were assumed. See Figure 6.2-14 for a composite temperature curve.

Note 4 The composite pressure curve in Figure 6.2-13 envelopes the limiting pressure curve from the Braidwood UHS Temperature increase.

Note 5 The composite temperature curve in Figure 6.2-14 is enveloped by the Environmental Qualification Temperature profile.

TABLE 6.2-1a

UNIT 2 CONTAINMENT PEAK PRESSURE AND TEMPERATURE

BREAK	PEAK PRESSURE (psig)	AVAILABLE MARGIN PSI	PEAK TEMPERATURE (°F)
<u>Primary Side Ruptures</u>			
Double-ended pump suction - Max SI (Note 1)	36.77	13.23	254.89
Double-ended pump suction - Min SI	38.37	11.63	256.69
Double-ended hot leg - Min SI	37.73	12.27	256.53

TABLE 6.2-1a (Cont'd)

UNIT 2 CONTAINMENT PEAK PRESSURE AND TEMPERATURE

BREAK	PEAK PRESSURE (psig)	AVAILABLE MARGIN PSI	PEAK TEMPERATURE (°F)
<u>Secondary Side Breaks</u>			
<u>Limiting Pressure Cases for Composite Curve (Note 2)</u>			
Full double-ended break - 95.1% power, (RCFC train failure)	35.6	14.4	N/A
Full double-ended break - 28.0% power, (RCFC train failure)	37.8	12.2	N/A
Full double-ended break - 0% power, (RCFC train failure)	38.3	11.7	N/A
Full double-ended break - 28.0% power, (feedwater isolation valve failure)	36.7	13.3	N/A
1.0 ft ² double ended break - 28.0% power, (LOOP with emergency diesel generator failure)	28.4	21.6	N/A
0.86 ft ² split break - 28.0% power, (LOOP with emergency diesel generator failure)	28.4	21.6	N/A
Full double-ended break - 28.0% power, (LOOP with emergency diesel generator failure)	32.5	17.5	N/A
<u>Limiting Pressure Cases (No LOOP) for UHS Temperature Increase Analysis (Note 4)</u>			
Full double-ended break - 0% power, (RCFC train failure)	33.83	16.17	N/A
Full double-ended break - 0% power (FIV failure)	32.53	17.47	N/A
Full double-ended break - 30% power (MSIV failure)	33.62	16.38	N/A
Full double-ended break - 0% power (MSIV failure)	34.32	16.68	N/A

TABLE 6.2-1a (Cont'd)

UNIT 2 CONTAINMENT PEAK PRESSURE AND TEMPERATURE

BREAK	PEAK PRESSURE (psig)	AVAILABLE MARGIN PSI	PEAK TEMPERATURE (°F)
0.62 ft ² split break - 0% power (RCFC failure)	33.54	16.46	N/A
0.83 ft ² split break - 30% power (MSIV failure)	34.44	15.56	N/A
<u>Secondary Side Breaks</u>			
<u>Limiting Temperature Cases for Composite Curve (Note 3)</u>			
Full double-ended break - 28.0% power, (RCFC train failure)	N/A	N/A	282.4
Full double-ended break - 0% power, (RCFC train failure)	N/A	N/A	280.9
Full double-ended break - 95.1% power, (feedwater isolation valve failure)	N/A	N/A	281.7
1.0 ft ² double-ended break - 65.3% power, (RCFC train failure)	N/A	N/A	305.6
1.0 ft ² double-ended break - 28.0% power, (RCFC train failure)	N/A	N/A	304.0
0.82 ft ² split break - 100% power, (RCFC train failure)	N/A	N/A	307.0
1.0 ft ² double-ended break - 0% power, (RCFC train failure)	N/A	N/A	299.1
1.0 ft ² double-ended break - 95.1% power, (MSIV failure)	N/A	N/A	326.3
0.91 ft ² split break - 95.1% power, (RCFC train failure)	N/A	N/A	313.1
Full double-ended break - 95.1% power, (LOOP with emergency diesel generator failure)	N/A	N/A	281.7

TABLE 6.2-1a (Cont'd)

UNIT 2 CONTAINMENT PEAK PRESSURE AND TEMPERATURE

BREAK	PEAK PRESSURE (psig)	AVAILABLE MARGIN PSI	PEAK TEMPERATURE (°F)
Full double-ended break - 28.0% power, (LOOP with emergency diesel generator failure)	N/A	N/A	282.4
1.0 ft ² double-ended break - 28.0% power, (LOOP with emergency diesel generator failure)	N/A	N/A	310.6
1.0 ft ² double-ended break - 95.1% power, (LOOP with MSIV failure)	N/A	N/A	330.8
0.91 ft ² split break - 95.1% power, (LOOP with emergency diesel generator failure)	N/A	N/A	322.6
0.86 ft ² split break - 28.0% power, (LOOP with emergency diesel generator failure)	N/A	N/A	317.7
<u>Limiting Temperature Cases (LOOP)</u> <u>for UHS Temperature Increase</u> <u>Analysis (Note 5)</u>			
Small double-ended break - 100% power (MSIV failure)	N/A	N/A	323.0
Small double-ended break - 70% power (MSIV failure)	N/A	N/A	323.0
Full double-ended break - 70% power (FIV failure)	N/A	N/A	239.8
Small double-ended break - 70% power (RCFC failure)	N/A	N/A	306.4
Full double-ended break - 100% power (MSIV failure)	N/A	N/A	248.2
Full double-ended break - 100% power (RCFC train failure)	N/A	N/A	234.1
0.62 ft ² split break - 0% power (MSIV failure)	N/A	N/A	293.1

TABLE 6.2-1a (Cont'd)

UNIT 2 CONTAINMENT PEAK PRESSURE AND TEMPERATURE

-
- Note 1 This case was not reanalyzed for the MUR uprate or the UHS temperature increase analyses.
- Note 2 For these cases, 120°F initial containment temperature and 15.7 psia initial containment pressure were assumed. See Figure 6.2-13c for a composite pressure curve.
- Note 3 For these cases, 120°F initial containment temperature and 14.6 psia initial containment pressure were assumed. See Figure 6.2-14c for a composite temperature curve.
- Note 4 The composite pressure curve in Figure 6.2-13C envelopes the limiting pressure curve from the Braidwood UHS temperature increase.
- Note 5 The composite temperature curve in Figure 6.2-14C is enveloped by the EQ temperature profile.

TABLE 6.2-2

ASSUMPTIONS FOR UNIT 1 CONTAINMENT ANALYSIS

Initial Containment Conditions		
	Temperature (°F)	
	LOCA	120
Cases	MSLB Limiting Temperature	120
	MSLB Limiting Pressure Cases	130
	Pressure (psia)	
	LOCA	15.7
Cases	MSLB Limiting Temperature	14.6
	MSLB Limiting Pressure Cases	15.7
	Relative Humidity (%)	20
	Net free volume (ft ³)	2.758 X 10 ⁶
	Essential service water temperature (°F)	104 (Note 1)
	Refueling water storage tank temperature (°F)	
	LOCA	105
	MSLB Limiting Temperature Cases	120
	MSLB Limiting Pressure Cases	130
	RWST deliverable water volume (gal)	
	ECCS/CS injection (above lo-lo setpoint)	180,888
	CS injection (after ECCS switchover to recirculation)	146,084
	TOTAL	326,972
	Number of fan coolers	
	TOTAL	4
	Operating maximum	4
	Operating minimum/single failure (RCFC train failure or EDG failure)	2
	Number of spray pumps	2
	2 pump deliverable flow (gpm)	7080
	1 pump deliverable flow (gpm)	3113
	(CS train failure or EDG failure)	
	Condensate Revaporization (%)	
	MSLB > 1.0-ft ²	100
	MSLB ≤ 1.0-ft ²	0

Note 1: This value reflects the UHS temperature post-LOCA for Braidwood. The higher Braidwood UHS temperature was also used for Byron.

TABLE 6.2-3

ASSUMPTIONS FOR UNIT 2 CONTAINMENT ANALYSIS

Initial Containment Conditions

Temperature (°F)		
LOCA		120
MSLB Limiting Temperature Cases		120
MSLB Limiting Pressure Cases		130
Pressure (psia)		
LOCA		15.7
MSLB Limiting Temperature Cases		14.6
MSLB Limiting Pressure Cases		15.7
Relative Humidity (%)		20
Net free Volume (ft ³)		2.758 x 10 ⁶
Essential service water temperature (°F)	104 (Note 1)	
Refueling water storage tank temperature (°F)		
LOCA		105
MSLB Limiting Temperature Cases		120
MSLB Limiting Pressure Cases		130
RWST deliverable water volume (gal)		
ECCS/CS injection (above lo-lo setpoint)		180,888
CS injection (after ECCS switchover to recirculation)		146,084
TOTAL		326,972
Number of fan coolers		
TOTAL		4
Operating maximum		4
Operating minimum/single failure (RCFC train failure or EDG failure)		2
Number of spray pumps		2
2 pump deliverable flow (gpm)		7080
2 pump deliverable flow - MSLB, loss of offsite power (gpm)*		6938
1 pump deliverable flow, CS train failure or LOCA EDG failure (gpm)		3113
1 pump deliverable flow - MSLB EDG failure (gpm)*		3113
Condensate Revaporization (%)		
MSLB > 1.0-ft ²		100
MSLB ≤ 1.0-ft ²		0

*includes 2% reduction for additional margin

Note 1: This value reflects the UHS temperature post-LOCA for Braidwood. The higher Braidwood UHS temperature was also used for Byron.

TABLE 6.2-4

CONTAINMENT HEAT SINKS - ANALYSIS VALUES

	WALL DESCRIPTION	HEAT TRANSFER AREA (ft ²)	MATERIAL	THICK- NESS (ft)
1.	Containment cylinder wall	72,741	Paint Concrete Carbon steel	8.30E-04 0.7500 0.0208
2.	Containment dome	17,550	Paint Concrete Carbon steel	8.30E-04 0.7500 0.0208
3.	Unlined concrete - combined from containment floor and the slab at El. 425'-0"	16,037	Concrete*	0.7500
4.	Lined concrete - combined from containment floor and reactor pool wall	848	Stainless steel Concrete	4.15E-02 0.7500
5.	Unlined concrete - combined reactor cavity, outside reactor wall, and reactor pool wall	4,803	Concrete	1.0000
6.	Lined concrete - secondary wall	7,702	Paint Carbon steel Concrete	8.30E-04 0.0766 0.7500
7.	Lined concrete - slab at El. 425'-0" lining only	422.3	Paint Carbon steel	8.30E-04 0.0625
8.	Unlined concrete - combined from slabs on steel beams at El. 412'-0" and 426'-0", instrument access tunnel, and enclosures for steam generator, reactor coolant pumps, etc.	69,541	Concrete	0.7500
9.	Lined concrete - Slabs on steel beams at El. 412'-0" and 426'-0"	3,852	Paint Carbon steel Concrete	8.30E-04 0.0040 0.7500
10.	Lined concrete - Enclosures for steam generator, reactor coolant pumps, etc	1,570	Paint Carbon steel Concrete	8.30E-04 0.0710 0.7500

TABLE 6.2-4 (Cont'd)

WALL DESCRIPTION	HEAT TRANSFER AREA (ft ²)	MATERIAL	THICK- NESS (ft)
11. Lined concrete - refueling cavity	2129	Stainless steel Concrete	0.0690 0.7500
12. Miscellaneous steel plates, HVAC hangers, polar crane trolley and bridge plates, and NSSS supports	19,791	Paint Carbon steel	8.30E-04 0.0416
13. Miscellaneous steel plates, grating, pressurizer relief tank, polar crane bridge plates, and return air riser	94,670	Paint Carbon steel	8.30E-04 0.0210
14. Polar crane trolley and bridge plates and machinery	14,089	Paint Carbon steel	8.30E-04 0.0760
15. Combined from manipulator crane fan, RCFC fan, and reactor cavity fans	21,875	Paint Carbon steel	8.30E-04 0.0400
16. Combined from containment charcoal filter unit housing, HVAC hangers, uninsulated pipe, ductwork, and duct supports	22,528	Paint Carbon steel	8.30E-04 0.0150
17. Cable/conduit trays	27,095	Paint Carbon steel	8.30E-04 0.0104
18. Combined from cable/conduit tray supports, junction boxes, and incore flux mapping equipment	6,385	Paint Carbon steel	8.30E-04 8.20E-03
19. Combined from charcoal filter unit, and miscellaneous steel beams and columns	69,856	Paint Carbon steel	8.30E-04 0.0157
20. Lined concrete - combined from the instrument access tunnel, reactor cavity, and inside reactor pool	9,291	Stainless steel Concrete	0.0165 0.7500

*This material is modeled in contact with water.

TABLE 6.2-4a

CONTAINMENT HEAT SINKS - NOMINAL VALUES

	WALL DESCRIPTION	HEAT TRANSFER AREA (ft ²)	MATERIAL	THICK- NESS (ft)
1.	Containment cylinder	80,823	Concrete Carbon steel	0.7500 0.0208
2.	Containment dome	19,500	Concrete Carbon steel	0.7500 0.0208
3.	Containment floor and operating deck	17,819	Concrete operating deck	0.7500
4.	Reactor cavity and reactor cavity support walls	987	Concrete Stainless steel	0.7500 0.0415
5.	Reactor cavity exterior reactor cavity wall	5,337	Concrete	1.0000
6.	Exterior reactor cavity wall and secondary shield	10,269	Concrete Carbon steel wall	0.7500 0.0766
7.	Operating deck	563	Carbon steel	0.0625
8.	Miscellaneous unlined concrete	77,348	Concrete	0.7500
9.	Miscellaneous steel- lined concrete	4,360	Concrete Carbon steel	0.7500 0.0040
10.	Enclosures for steam generator, pressurizers, and reactor pumps	2,094	Concrete Carbon steel	0.7500 0.0710
11.	Refueling cavity	2,839	Concrete Stainless steel	0.7500 0.0690
12.	Miscellaneous A	20,914	Carbon steel	0.0416
13.	Miscellaneous B	97,182	Carbon steel	0.0210

TABLE 6.2-4a (Cont'd)

WALL DESCRIPTION	HEAT TRANSFER AREA (ft ²)	MATERIAL	THICK- NESS (ft)
14. Trolley plate and bridge plate	14,089	Carbon steel	0.0760
15. Miscellaneous C	22,679	Carbon steel	0.0400
16. Miscellaneous D	23,485	Carbon steel	0.0150
17. Miscellaneous E	30,404	Carbon steel	0.0104
18. Miscellaneous F	6,384	Carbon steel	0.0082
19. Steel beams and columns	75,094	Carbon steel	0.0157
20. Access tunnels and reactor cavity	10,353	Concrete Stainless steel	0.7500 0.0165

NOTE: All carbon steel is modeled with a layer of paint with a thickness = 0.00083 ft

TABLE 6.2-5

THERMOPHYSICAL PROPERTIES OF CONTAINMENT HEAT SINKS

MATERIAL	THERMAL CONDUCTIVITY (Btu/hr-ft-°F)	VOLUMETRIC HEAT CAPACITY (Btu/ft ³ -°F)
Paint	00.30	28.00
Carbon steel	27.00	58.80
Stainless steel	09.00	53.70
Concrete	00.92	22.62

TABLE 6.2-6

LOCA SEQUENCE OF EVENTS FOR DOUBLE-ENDED PUMP
SUCTION BREAK MIN SI, UNIT 1

Time of Occurrence (sec)	Event
14.8	Broken Loop Accumulator Begins Injecting Water
14.9	Intact Loop Accumulators Begins Injecting Water
24.2	End of Blowdown Phase
43.6	Safety Injection Begins
64.75	Broken Loop Accumulator Water Injection Ends
65.0	Start Fan Coolers
65.55	Intact Loop Accumulators Water Injection Ends
110.2	Start Spray
223.65	End of Reflood
716.36	Containment Peak Pressure and Temperature
1110.	Recirculation, Injection
3778.	Recirculation, Spray
28800.	Containment Spray Terminated

TABLE 6.2-6a

LOCA SEQUENCE OF EVENTS FOR DOUBLE-ENDED PUMP
SUCTION BREAK MIN SI, UNIT 2

Time of Occurrence (sec)	Event
12.9	Broken Loop Accumulator Begins Injecting Water
13.1	Intact Loop Accumulators Begins Injecting Water
22.2	End of Blowdown Phase
44.4	Safety Injection Begins
60.05	Broken Loop Accumulator Water Injection Ends
63.8	Intact Loop Accumulators Water Injection Ends
65.0	Start Fan Coolers
110.2	Start Spray
228.55	End of Reflood
592.2	Containment Peak Pressure and Temperature
1110.0	Recirculation, Injection
3778.	Recirculation, Spray
28800.	Containment Spray Terminated

TABLE 6.2-7

LOCA SEQUENCE FOR DOUBLE-ENDED HOT LEG BREAK, UNIT 1

Time of Occurrence (sec)	Event
14.2	Accumulator Begins Injecting
21.54	Containment Peak Pressure and Temperature
24.2	End of Blowdown Phase

Note: Double-ended hot leg breaks are only analyzed until the end of blowdown since double-ended pump suction breaks are limiting thereafter (see Section 6.2.1.3.4).

TABLE 6.2-8

LOCA SEQUENCE FOR DOUBLE-ENDED HOT LEG BREAK, UNIT 2

Time of Occurrence (sec)	Event
12.5	Accumulator Begins Injecting
19.73	Containment Peak Pressure and Temperature
22.4	End of Blowdown

Note: Double-ended hot leg breaks are only analyzed until the end of blowdown since double-ended pump suction breaks are limiting thereafter (see Section 6.2.1.3.4).

TABLE 6.2-9

MSLB ACCIDENT SEQUENCE OF EVENTS FOR 0.90 FT² SPLIT BREAK
AT 30% POWER WITH MS ISOLATION VALVE FAILURE
FOR UNIT 1 (PEAK PRESSURE)

EVENT	TIME OF OCCURRENCE (sec)
Main feedwater isolation	23
Steamline isolation	40
Start fan coolers	42.92
Containment peak temperature	51.7
Start sprays	196.2
Containment peak pressure	272.4
Steam generator dryout	1817

TABLE 6.2-9a

MSLB ACCIDENT SEQUENCE OF EVENTS FOR 1.0 FT² SPLIT BREAK
AT 100% POWER WITH LOSS OF OFFSITE POWER AND MS
ISOLATION VALVE FAILURE FOR UNIT 1 (PEAK TEMPERATURE)

EVENT	TIME OF OCCURRENCE (sec)
Main feedwater isolation	22.0
Steamline isolation	37.0
Start fan coolers	65
Containment peak temperature	65
Start sprays	153.1
Containment peak pressure	1685
Steam generator dryout	1816

TABLE 6.2-9b

MSLB ACCIDENT SEQUENCE OF EVENTS FOR 0.83 FT² DOUBLE-ENDED RUPTURE
AT 30% POWER WITH MSIV FAILURE FOR UNIT 2 (PEAK PRESSURE)

<u>EVENT</u>	<u>TIME OF OCCURRENCE (sec)</u>
Main feedwater isolation	25.0
Start fan coolers	41.85
Steamline isolation	43.0
Containment peak temperature	55.7
Start sprays	195.3
Containment peak pressure	297.5
Steam generator dryout	1820

TABLE 6.2-9c

MSLB ACCIDENT SEQUENCE OF EVENTS FOR 1.0 FT² DOUBLE-ENDED RUPTURE
AT 100% POWER WITH LOSS OF OFFSITE POWER AND MAIN STEAM ISOLATION
VALVE FAILURE FOR UNIT 2 (PEAK TEMPERATURE)

<u>EVENT</u>	<u>TIME OF OCCURRENCE (sec)</u>
Main feedwater isolation	7.7
Steamline isolation	8.7
Start fan coolers	66.3
Containment peak temperature	66.3
Start sprays	810.2
Containment peak pressure	868.0
Steam generator dryout	1818

TABLE 6.2-10

SUBCOMPARTMENT NODAL DESCRIPTION

ELEMENT NO.	VOLUME (ft ³)	INITIAL CONDITIONS		
		TEMP. (°F)	AIR PRESS (psia)	STEAM PRESS. (psia)
1	36,152	120.00	14.05	0.85
2	33,294	120.00	14.05	0.85
3	35,011	120.00	14.05	0.85
4	41,024	120.00	14.05	0.85
5	38,625	120.00	14.05	0.85
6	36,251	120.00	14.05	0.85
7	2,254,200	120.00	14.05	0.85
8	9,983	120.00	14.05	0.85
9	3,742	120.00	14.05	0.85
10	4,159	120.00	14.05	0.85
11	15,677	120.00	14.05	0.85
12	20,743	120.00	14.05	0.85
13	9,914	120.00	14.05	0.85
14	3,515	120.00	14.05	0.85
15	5,435	120.00	14.05	0.85
16	25,159	120.00	14.05	0.85
17	6,968	120.00	14.05	0.85
18	10,232	120.00	14.05	0.85
19	39,190	120.00	14.05	0.85
20	51,611	120.00	14.05	0.85
21	24,844	120.00	14.05	0.85
22	6,250	120.00	14.05	0.85
23	12,236	120.00	14.05	0.85
24	3,145	120.00	14.05	0.85
25	11,472	120.00	14.05	0.85
26	11,138	120.00	14.05	0.85
27	2,838	120.00	14.05	0.85
28	4,993	120.00	14.05	0.85

B/B-UFSAR

TABLE 6.2-11

SUBCOMPARTMENT FLOW PATH DESCRIPTION

BETWEEN COMPTS.	FLOW PATH NO.	K-FAC ⁽¹⁾	F-FAC ⁽²⁾	LENGTH ⁽³⁾	HYDR. ⁽⁴⁾ D.	FLOW ⁽⁵⁾ A	EQUI. ⁽⁶⁾ A	A/A ⁽⁷⁾
1-16	1H	3.6530E+00	2.2000E-02	8.0400E+00	4.2000E+00	2.1000E+01	7.3100E+00	1.5900E-92
2-1	2H	5.9000E-01	2.2000E-02	4.0000E+-1	1.1000E+01	5.7200E+02	4.0000E+01	5.4170E-01
3-4	3H	5.0000E+00	2.2000E-02	8.0000E+01	1.0000E+01	2.2000E+02	7.0000E+01	1.2200E-01
4-28	4H	1.7000E+00	2.2000E-02	9.7100E+00	1.0900E+00	1.9400E+01	2.0000E+00	1.3620E-01
5-6	5H	5.9000E-01	2.2000E-02	4.0000E+01	1.1000E+01	5.7200E+02	4.0000E+01	5.4170E-01
6-1	6H	1.0200E+00	2.2000E-02	5.2000E+01	1.5000E+01	5.7800E+02	5.3000E+01	8.2110E-01
7-6	7H	2.5300E+00	2.2000E-02	8.5400E+01	4.7300E+01	2.3200E+01	5.1510E+01	2.1280E-01
8-15	8H	1.7000E+00	2.2000E-02	4.3000E+01	1.0580E+01	1.3300E+02	4.3000E+01	5.5630E-01
9-8	9H	2.5800E-01	2.2000E-02	2.7250E+01	1.0600E+01	1.1900E+02	3.8500E+01	5.0000E-01
11-10	11H	2.5150E+00	2.2000E-02	3.2530E+01	1.1050E+01	1.8700E+02	2.4940E+01	7.4200E-01
12-20	12H	2.3500E+00	2.2000E-02	1.6600E-01	6.3240E+02	6.3240E+02	6.9500E+00	3.9600E-01
13-12	13H	2.0500E-01	2.2000E-02	3.4110E+01	1.2130E+01	1.8200E+02	3.4070E+01	7.8030E+01
14-15	14H	2.1500E+00	2.2000E-02	3.2450E+01	1.0600E+01	1.1900E+02	2.6310E+01	5.0000E-01
16-17	16H	7.1000E-01	2.2000E-02	4.2630E+01	7.2000E+00	1.4000E+02	3.7940E-01	2.3530E-01
17-18	17H	3.3300E-01	2.2000E-02	1.7380E+01	1.1910E+01	2.6650E+02	1.5430E+01	4.3200E-01
18-19	18H	9.6700E-01	2.2000E-02	3.2420E+01	7.1800E+00	1.4000E+02	2.5900E+01	2.3530E-01
19-20	19H	1.7480E+00	2.2000E-02	7.1800E+01	1.1320E+01	1.3300E+02	5.6370E+01	2.3750E-01
20-21	20H	8.2900E-01	2.2000E-02	4.7420E+01	7.3100E+00	1.4000E+02	3.9700E+01	2.5000E-01
21-22	21H	1.9110E+00	2.2000E-02	9.3800E+00	3.7800E+00	7.0000E+01	3.9700E+00	1.1760E-01
22-23	22H	9.8400E-01	2.2000E-02	4.9180E+01	7.1800E+00	1.4000E+02	4.2230E+01	2.3550E-01
23-16	23H	9.7000E-01	2.2000E-02	3.3930E+01	7.2000E+00	1.4000E+02	2.8170E+01	2.3550E-01
24-18	24H	3.1140E+00	2.2000E-02	3.1500E+00	3.6800E+01	1.7508E+01	2.6300E+00	1.8500E-02
25-17	25H	8.7600E-01	2.2000E-02	8.6900E+00	6.8200E+00	9.4500E+02	6.8200E+00	6.8970E-01
26-22	26H	1.2000E-01	2.2000E-02	9.2000E+00	2.6100E+01	8.4130E+02	8.6000E+00	8.0130E+01
1-7	1R	1.8400E+00	2.2000E-02	4.5000E+01	1.0000E+01	1.9700E+02	4.5000E+01	3.3910E-01
2-7	2R	1.8400E+00	2.2000E-02	6.0000E+01	1.0000E+01	1.8600E+02	6.0000E+01	3.2010E-01
3-7	3R	1.8400E+00	2.2000E-02	4.5000E+01	1.0000E+01	2.1900E+02	4.5000E+01	3.7700E-01
4-7	4R	1.8400E+00	2.2000E-02	4.5000E+01	1.0000E+01	1.7900E+02	4.5000E+01	3.0810E-01

B/B-UFSAR

TABLE 6.2-11 (Cont'd)

BETWEEN COMPTS.	FLOW PATH NO.	K-FAC ⁽¹⁾	F-FAC ⁽²⁾	LENGTH ⁽³⁾	HYDR. ⁽⁴⁾ D.	FLOW ⁽⁵⁾ A	EQUI. ⁽⁶⁾ A	A/A ⁽⁷⁾
5-7	5R	1.8400E+00	2.2000E-02	6.0000E+01	1.0000E+01	1.9050E+02	6.0000E+01	3.2790E-01
6-7	6R	1.8400E+00	2.2000E-02	4.5000E+01	1.0000E+01	1.9900E+02	4.5000E+01	3.4240E-01
7-15	7R	1.8500E+00	2.2000E-02	1.8000E+00	4.7000E-01	9.6400E+01	4.7000E-02	1.6710E-01
8-7	8R	2.2300E+00	2.2000E-02	1.2200E+00	2.6000E-01	9.0000E+01	2.8000E-02	1.4170E-01
9-10	9R	2.5800E-01	2.2000E-02	2.0000E+01	1.0600E+01	1.1900E+02	1.8000E+01	5.0000E-01
11-7	11R	1.7900E+00	2.2000E-02	2.0900E+00	2.3000E-01	3.3280E+02	1.2000E-01	2.6650E-01
12-7	12R	1.8900E+00	2.2000E-02	2.6600E+00	2.000E-01	5.0400E+02	2.3000E-01	3.7530E-01
13-7	13R	1.6200E+00	2.2000E-02	3.3500E+00	1.5300E-01	1.7600E-02	1.3500E+00	4.8400E-01
14-7	14R	1.1400E+00	2.2000E-02	1.4800E+01	1.3300E-01	4.8000E+01	3.1770E+00	1.0710E-01
16-8	16R	3.7400E-01	2.2000E-02	2.3770E+01	7.9200E+00	2.9700E+02	2.1160E+01	3.8900E-01
17-9	17R	2.1560E+00	2.2000E-02	2.2270E+01	1.1000E-01	1.1480E+02	2.0760E+01	4.3610E-01
18-10	18R	2.2340E+00	2.2000E-02	1.1800E+00	1.3300E-01	4.5000E+01	5.9000E-01	1.5390E-01
19-11	19R	1.8430E+00	2.2000E-02	1.7080E+01	1.7800E-01	4.7300E+02	1.5480E+01	4.8360E-01
21-13	21R	2.0000E+00	2.2000E-02	1.2500E+01	1.3300E-01	2.0400E+02	6.3900E+00	5.0000E-01
25-7	25R	1.0000E+00	2.2000E-02	4.4710E+01	9.2100E+00	1.9800E+02	3.5500E+01	1.0000E+00
26-14	26R	2.7200E=01	2.2000E-02	1.5100E+01	1.9100E+01	4.2090E+02	1.2840E+01	4.7840E-01
27-7	27R	1.6400E+00	2.2000E-02	2.6000E+01	6.1900E+01	8.2870E+00	8.3800E-01	7.8200E-01
28-7	28R	7.0000E-01	2.2000E-02	2.0070E+01	3.0500E+00	5.8200E+01	1.8700E+01	4.0870E-01
1-7	1A	2.5300E+00	2.2000E-02	8.5400E+01	4.7300E+00	2.3200E+01	5.1510E+01	2.1280E-01
2-3	2A	5.9000E-01	2.2000E-02	4.0000E+01	1.1000E+01	5.7200E+02	4.0000E+01	5.4170E-01
3-7	3A	2.5300E+00	2.2000E-02	8.5400E+01	4.7300E+00	2.3200E+01	5.1510E+01	2.1280E-01
4-7	4A	2.5300E+00	2.2000E-02	8.5400E+01	4.7300E+00	2.3200E+01	5.1510E+01	2.1280E-01
5-4	5A	5.9000E-01	2.2000E-02	4.0000E+01	1.1000E+01	5.7200E+02	4.0000E+01	5.4170E-01
11-12	11A	1.2730E+00	2.2000E-02	3.3590E+01	4.8000E+00	3.6000E+01	1.9070E+01	1.6800E-01
13-14	13A	2.5000E-01	2.2000E-02	2.3000E+01	1.0600E+01	1.1900E+02	1.9500E+01	5.0000E-01
14-22	14A	1.0000E+00	2.2000E-02	7.8200E+00	1.3300E-01	7.8800E+00	3.0000E+00	3.0000E-02
15-23	15A	1.2650E+00	2.2000E-02	6.6300E+00	1.3300E-01	1.3980E+02	1.7200E+00	1.8800E-01
25-9	25A	2.4750E+00	2.2000E-02	2.7040E+01	1.2930E+01	2.2950E+02	2.5840E+01	6.0720E-01
26-7	26A	1.0000E+00	2.2000E-02	4.4710E+01	9.2100E+00	1.9800E+02	3.5500E+01	1.0000E+00

TABLE 6.2-11 (Cont'd)

NOTES:

1. Factor for form loss and area change pressure drop calculation.
2. Friction factor for frictional pressure drop calculation.
3. Length for inertial pressure drop calculation.
4. Hydraulic diameter for frictional pressure drop calculation.
5. Vent flow area.
6. Equivalent length for frictional pressure drop calculation.
7. Minimum area/maximum area for compressibility effects.

Table 6.2-11a has been deleted intentionally.

B/B-UFSAR

TABLE 6.2-11b

SUBCOMPARTMENT NODAL DESCRIPTION

NODE NO.	DESCRIPTION	VOLUME (ft ³)	HEIGHT (ft)	FLOW CROSS- SECTIONAL AREA (ft ²)	BOTTOM ELEVA- TION (ft)	INITIAL CONDITIONS			CALC. PEAK PRESS. DIFF.* (psid)	
						TEMP (°F)	PRESS. (psia)	RELATIVE HUMIDITY (%)	Case A	Case B
1	RPV-Shield Annulus	6.95	2.25	2.80	397.75	122.	15.00	0.1	-30.5	-18.0
2	RPV-Shield Annulus	6.95	2.25	2.80	397.75	122.	15.00	0.1	-21.5	-9.8
3	RPV-Shield Annulus	6.95	2.25	2.80	397.75	122.	15.00	0.1	-7.8	-5.5
4	RPV-Shield Annulus	20.85	2.25	8.40	397.75	122.	15.00	0.1	-3.0	-2.4
5	RPV-Shield Annulus	6.95	2.25	2.80	397.75	122.	15.00	0.1	-9.8	-6.9
6	RPV-Shield Annulus	6.95	2.25	2.80	397.75	122.	15.00	0.1	-22.2	-10.3
7	RPV-Shield Annulus	18.05	4.75	6.05	393.00	122.	15.00	0.1	-30.0	-12.2
8	RPV-Shield Annulus	19.10	4.75	6.05	393.00	122.	15.00	0.1	-19.3	-8.8
9	RPV-Shield Annulus	19.10	4.75	6.05	393.00	122.	15.00	0.1	-6.9	-6.5
10	RPV-Shield Annulus	55.25	4.75	18.15	393.00	122.	15.00	0.1	-2.9	-2.5
11	RPV-Shield Annulus	19.10	4.75	6.05	393.00	122.	15.00	0.1	-9.0	-5.8
12	RPV-Shield Annulus	18.05	4.75	6.05	393.00	122.	15.00	0.1	-23.0	-10.8
13	RPV-Shield Annulus	7.55	5.25	4.00	387.75	122.	15.00	0.1	-29.5	+8.0
14	RPV-Shield Annulus	8.10	5.25	1.50	387.75	122.	15.00	0.1	-17.8	-9.6
15	RPV-Shield Annulus	8.10	5.25	1.50	387.75	122.	15.00	0.1	-7.7	-4.2
16	RPV-Shield Annulus	23.25	5.25	4.50	387.75	122.	15.00	0.1	-4.7	-4.0
17	RPV-Shield Annulus	8.10	5.25	1.50	387.75	122.	15.00	0.1	-9.0	-7.7
18	RPV-Shield Annulus	7.55	5.25	1.50	387.75	122.	15.00	0.1	-21.3	-12.4
19	RPV-Shield Annulus	17.45	8.00	2.15	387.75	122.	15.00	0.1	+7.1	+8.4
20	RPV-Shield Annulus	17.45	8.00	2.15	387.75	122.	15.00	0.1	+6.8	+9.3
21	RPV-Shield Annulus	17.45	8.00	2.15	379.75	122.	15.00	0.1	+7.0	+8.9
22	RPV-Shield Annulus	52.35	8.00	6.45	379.75	122.	15.00	0.1	+8.8	+7.4

B/B-UFSAR

TABLE 6.2-11b (Cont'd)

NODE NO.	DESCRIPTION	VOLUME (ft ³)	HEIGHT (ft)	FLOW CROSS- SECTIONAL AREA (ft ²)	BOTTOM ELEVA- TION (ft)	INITIAL CONDITIONS			CALC. PEAK PRESS. DIFF.* (psid)	
						TEMP (°F)	PRESS. (psia)	RELATIVE HUMIDITY (%)	Case A	Case B
23	RPV-Shield Annulus	17.45	8.00	2.15	379.75	122.	15.00	0.1	+7.8	+8.8
24	RPV-Shield Annulus	17.45	8.00	2.15	379.75	122.	15.00	0.1	+7.2	+9.3
25	RPV-Shield Annulus	17.45	8.00	2.15	371.75	122.	15.00	0.1	+5.3	+4.9
26	RPV-Shield Annulus	17.45	8.00	2.15	371.75	122.	15.00	0.1	+4.4	+6.6
27	RPV-Shield Annulus	17.45	8.00	2.15	371.75	122.	15.00	0.1	+5.1	+7.0
28	RPV-Shield Annulus	52.35	8.00	6.45	371.75	122.	15.00	0.1	+6.3	+5.1
29	RPV-Shield Annulus	17.45	8.00	2.15	371.75	122.	15.00	0.1	+5.8	+7.1
30	RPV-Shield Annulus	17.45	8.00	2.15	371.75	122.	15.00	0.1	+5.2	+6.4
31	Inspection Cavity	226.35	10.50	23.45	389.50	122.	15.00	0.1	+31.2	+24.8
32	Inspection Cavity	201.62	10.50	19.25	389.50	122.	15.00	0.1	+28.3	+24.7
33	Inspection Cavity	210.68	10.50	19.25	389.50	122.	15.00	0.1	+18.9	+18.3
34	Inspection Cavity	341.44	10.50	37.20	389.50	122.	15.00	0.1	+15.2	+15.0
35	Inspection Cavity	303.80	10.50	28.95	389.50	122.	15.00	0.1	+15.7	+15.3
36	Inspection Cavity	210.68	10.50	19.25	389.50	122.	15.00	0.1	+21.9	+20.3
37	Inspection Cavity	217.28	10.50	23.45	389.50	122.	15.00	0.1	+29.2	+24.9
38	Inspection Cavity	3.95E4	21.25	2.225E	350.50	122.	15.00	0.1	+1.2	+1.9
39	Containment	3.15E7	2.5E3	1.55E3	350.50	122.	15.00	0.1		

*Peaks do not occur at the same time.

B/B-UFSAR

TABLE 6.2-11c

SUBCOMPARTMENT VENT PATH DESCRIPTION

VENT PATH NO.	FROM VOL. NODE NO.	TO VOL. NODE NO.	DESCRIPTION OF VENT PATH FLOW*	AREA** A ₂ (ft)	LENGTH L (ft)	$\Sigma \frac{L}{A}$ (ft ⁻¹)	HYDRAULIC DIAMETER (ft)	HEAD LOSS, K				
								FRICTION LOSS, K _f	TURNING LOSS, K _{b1}	EXPANSION & CONTRAC TION, K _E		TOTAL
1	1	2	unchoked	0.85	7.10	8.35	0.70	0.30	0.05	--	0.35	
2	2	3	choked (b)	0.85	7.10	8.35	0.70	0.30	0.05	--	0.35	
3	3	4	unchoked	0.85	14.20	16.70	0.70	0.60	0.10	--	0.70	
4	5	4	unchoked	0.85	14.20	16.70	0.70	0.60	0.10	--	0.70	
5	6	5	choked (b)	0.85	7.10	8.35	0.70	0.30	0.05	--	0.35	
6	1	6	unchoked	0.85	7.10	8.35	0.70	0.30	0.05	--	0.35	
7	7	8	unchoked	3.43	6.95	2.00	1.50	0.10	0.85	--	0.95	
8	8	9	choked (b)	1.57	6.95	4.50	1.50	0.02	0.18	0.45	0.65	
9	9	10	unchoked	1.43	13.90	9.60	1.50	0.04	0.32	1.04	1.40	
10	11	10	unchoked	1.57	13.90	9.00	1.50	0.04	0.36	0.90	1.30	
11	12	11	choked (b)	1.43	6.95	4.80	1.50	0.02	0.16	0.52	0.70	
12	7	12	unchoked	3.43	6.95	2.00	1.50	0.10	0.85	--	0.95	
13	13	14	unchoked	1.19	6.95	5.60	0.35	0.40	0.80	--	1.20	
14	14	15	choked (b)	0.47	6.95	14.15	0.35	0.05	0.10	0.60	0.75	
15	15	16	unchoked	0.43	13.30	13.30	31.00	0.35	0.10	1.10	1.50	
16	17	16	unchoked	0.47	13.30	28.30	0.35	0.10	0.20	1.20	1.50	
17	18	17	choked (b)	0.43	6.65	15.50	0.35	0.05	0.15	0.55	0.75	
18	18	18	choked (b)	1.19	6.65	5.60	0.35	0.40	0.35	--	0.75	
19	19	20	unchoked	2.15	6.65	3.10	0.55	0.38	0.07	--	0.45	
20	20	21	unchoked	2.15	6.65	3.10	0.55	0.38	0.07	--	0.45	
21	21	22	unchoked	2.15	13.30	6.20	0.55	0.76	0.14	--	0.90	
22	23	22	unchoked	2.15	13.30	6.20	0.55	0.76	0.14	--	0.90	
23	24	23	unchoked	2.15	6.65	3.10	0.55	0.38	0.07	--	0.45	
24	19	24	unchoked	2.15	6.65	3.10	0.55	0.38	0.07	--	0.45	
25	25	26	unchoked	2.15	6.65	3.10	0.55	0.38	0.07	--	0.45	
26	26	27	unchoked	2.15	6.65	3.10	0.55	0.38	0.07	--	0.45	
27	27	28	unchoked	2.15	13.30	6.20	0.55	0.76	0.14	--	0.90	

B/B-UFSAR

TABLE 6.2-11c (Cont'd)

VENT PATH NO.	FROM VOL. NODE NO.	TO VOL. NODE NO.	DESCRIPTION OF VENT PATH FLOW*	AREA** A ₂ (ft)	LENGTH L (ft)	$\Sigma \frac{L}{A}$ (ft ⁻¹)	HYDRAULIC DIAMETER (ft)	HEAD LOSS, K			
								FRICITION LOSS, K _f	TURNING LOSS, K _{b1}	EXPANSION & CONTRAC- TION, K _e	TOTAL
28	29	28	unchoked	2.15	13.30	6.20	0.55	0.76	0.14	--	0.90
29	30	29	unchoked	2.15	6.65	3.10	0.55	0.38	0.07	--	0.45
30	25	30	unchoked	2.15	6.65	3.10	0.55	0.38	0.07	--	0.45
31	1	39	choked (b)	1.05	1.75	1.05	0.75	0.01	--	2.04	2.05
32	2	39	choked (b)	1.05	1.75	1.05	0.75	0.01	--	2.04	2.05
33	3	39	choked (b)	1.05	1.75	1.05	0.75	0.01	--	2.04	2.05
34	4	39	unchoked	3.15	1.75	0.35	0.75	0.01	--	2.04	2.05
35	5	39	unchoked	1.05	1.75	1.05	0.75	0.01	--	2.04	2.05
36	6	39	choked (b)	1.05	1.75	1.05	0.75	0.01	--	2.04	2.05
37	7	1	unchoked	2.80	3.50	0.90	1.75	0.07	--	0.28	0.35
38	8	2	unchoked	2.80	3.50	0.90	1.75	0.07	--	0.28	0.35
39	9	3	unchoked	2.80	3.50	0.90	1.75	0.07	--	0.28	0.35
40	10	4	unchoked	8.40	3.50	0.30	1.75	0.07	--	0.28	0.35
41	11	5	unchoked	2.80	3.50	0.90	1.75	0.07	--	0.28	0.35
42	12	6	unchoked	2.80	3.50	0.90	1.75	0.07	--	0.28	0.35
43	7	13	choked (b)	0.73	5.00	6.85	1.75	0.07	--	0.21	0.45
44	8	14	unchoked	0.83	5.00	6.05	1.75	0.07	--	0.21	0.45
45	9	15	choked (b)	0.83	5.00	6.05	1.75	0.24	--	0.28	0.45
46	10	16	unchoked	2.29	5.00	2.20	1.75	0.24	--	0.21	0.45
47	11	17	choked (b)	0.83	5.00	6.05	1.75	0.24	--	0.21	0.45
48	12	18	unchoked	0.73	5.00	6.85	1.75	0.24	--	0.21	0.45
49	13	19	choked (b)	1.10	6.63	4.80	0.35	0.60	--	0.15	0.75
50	14	20	choked (b)	1.10	6.63	4.80	0.35	0.60	--	0.15	0.75
51	15	21	unchoked	1.10	6.63	4.80	0.35	0.60	--	0.15	0.75
52	16	22	unchoked	3.30	6.63	1.60	0.35	0.60	--	0.15	0.75
53	17	23	unchoked	1.10	6.63	4.80	0.35	0.60	--	0.15	0.75
54	18	24	choked (b)	1.10	6.63	4.80	0.35	0.60	--	0.15	0.75
55	19	25	unchoked	1.80	8.00	4.50	0.55	0.70	--	0.15	0.70
56	20	26	unchoked	1.80	8.00	4.50	0.55	0.70	--	--	0.70

B/B-UFSAR

TABLE 6.2-11c (Cont'd)

VENT PATH NO.***	FROM VOL. NODE NO.	TO VOL. NODE NO.	DESCRIPTION OF VENT PATH FLOW*	AREA** A ₂ (ft)	LENGTH L (ft)	$\Sigma \frac{L}{A}$ (ft ⁻¹)	HYDRAULIC DIAMETER (ft)	HEAD LOSS, K			
								EXPANSION & CONTRAC- TION, K _ε			TOTAL
								FRICITION LOSS, K _f	TURNING LOSS, K _{b1}		
57	21	27	unchoked	1.80	8.00	4.50	0.55	0.70	--	--	0.70
58	22	28	unchoked	5.40	8.00	1.50	0.55	0.70	--	--	0.70
59	23	29	unchoked	1.80	8.00	4.50	0.55	0.70	--	--	0.70
60	24	30	unchoked	1.80	8.00	4.50	0.55	0.70	--	--	0.70
61	25	38	unchoked	1.80	8.00	6.90	0.55	1.05	--	--	1.90
62	26	38	unchoked	1.80	14.75	6.90	0.55	1.05	--	0.85	1.90
63	27	38	unchoked	1.80	14.75	6.90	0.55	1.05	--	0.85	1.90
64	28	38	unchoked	5.40	14.75	2.30	0.55	1.05	--	0.85	1.90
65	29	38	unchoked	1.80	14.75	6.90	0.55	1.05	--	0.85	1.90
66	30	38	unchoked	1.80	14.75	6.90	0.55	1.05	--	0.85	1.90
67	38	39	unchoked	112.75	65.00	0.60	10.50	0.02	0.73	1.00	1.75
68	31	32	choked (a)	18.00	8.65	0.50	3.95	0.05	0.50	--	0.55
69	43	33	choked	7.60	8.65	1.15	3.95	0.01	0.09	0.50	0.60
70	33	34	choked	6.50	10.80	1.65	3.95	0.01	0.14	0.65	0.80
71	34	35	unchoked	7.10	13.00	1.85	3.95	0.02	0.08	0.55	0.65
72	36	35	choked	6.50	10.80	1.65	3.95	0.01	0.11	0.98	1.10
73	37	36	choked	8.20	8.65	1.05	3.95	0.01	0.12	0.32	0.45
74	31	37	choked	18.00	8.65	0.50	3.95	0.05	0.50	--	0.55
75	31	7	choked (b)	4.00	3.75	0.95	1.00	--	--	1.80	1.80
76	32	8	choked	1.50	3.25	2.20	0.35	--	--	1.70	1.70
77	33	9	choked	1.50	3.25	2.20	0.35	--	--	1.70	1.70
78	34	10	choked	1.74	3.75	2.20	0.30	--	--	1.80	1.80
79	35	10	choked (b)	2.08	3.50	1.65	0.30	--	--	1.75	1.75
80	36	11	choked (a)	1.50	3.25	2.20	0.35	--	--	1.70	1.70
81	37	12	choked (a)	1.16	3.75	3.25	0.25	--	--	1.80	1.80
82	31	13	choked (b)	4.00	3.75	0.95	1.00	--	--	1.80	1.80
83	32	14	choked (a)	1.28	3.25	2.55	0.35	--	--	1.70	1.70
84	33	15	unchoked	1.50	3.25	2.20	0.35	--	--	1.70	1.70
85	34	16	choked (b)	1.29	3.75	2.95	0.30	--	--	1.80	1.80

B/B-UFSAR

TABLE 6.2-11c (Cont'd)

VENT PATH NO.***	FROM VOL. NODE NO.	TO VOL. NODE NO.	DESCRIPTION OF VENT PATH FLOW*	AREA** A ₂ (ft)	LENGTH L (ft)	$\sum \frac{L}{A}$ (ft ⁻¹)	HYDRAULIC DIAMETER (ft)	HEAD LOSS, K			TOTAL
								FRICITION LOSS, K _f	TURNING LOSS, K _{bl}	EXPANSION & CONTRAC TION, K _e	
86	35	16	choked (b)	1.86	3.50	1.85	0.30	--	--	1.75	1.75
87	36	17	unchoked	1.50	3.25	2.20	0.35	--	--	1.70	1.70
88	37	18	choked (a)	0.71	3.75	5.30	0.25	--	--	1.80	1.80
89	31	39	choked	23.45	--	0.45	--	--	--	--	3.15
90	32	39	unchoked	19.25	--	0.70	--	--	--	--	4.00
91	33	39	unchoked	19.25	--	0.70	--	--	--	--	4.00
92	34	39	unchoked	37.20	--	0.30	--	--	--	--	4.35
93	35	39	unchoked	28.95	--	0.40	--	--	--	--	4.00
94	36	39	unchoked	19.25	--	0.70	--	--	--	--	4.00
95	37	39	unchoked	23.45	--	0.45	--	--	--	--	4.35
96	0	31	blowdown	1.00	--	0.00	--	--	--	--	0.00

* pertains to both cases, a and b, unless otherwise noted.

** minimum cross-sectional area.

*** Under sufficient pressure, junctions 89 through 96 become available as a result of hinged shield doors geometry.

TABLE 6.2-12

SUMMARY OF SUBCOMPARTMENT PRESSURE DIFFERENTIALS

ELEMENT NO.	DESCRIPTION	BREAK CONSIDERED	PEAK PRESSURE DIFFERENTIAL (psi)
1	Loop Compartment	DECL*	14.02 @ .396 sec.
2	Loop Compartment	DECL*	15.02 @ .352 sec.
3	Loop Compartment	DECL*	19.39 @ .205 sec.
4	Loop Compartment	DECL*	19.24 @ .244 sec.
5	Loop Compartment	DECL*	15.06 @ .383 sec.
6	Loop Compartment	DECL*	14.14 @ .408 sec.
1	Loop Compartment	DEHL*	14.69 @ .108 sec.
2	Loop Compartment	DEHL*	14.52 @ .133 sec.
3	Loop Compartment	DEHL*	20.27 @ .123 sec.
4	Loop Compartment	DEHL*	19.81 @ .137 sec.
5	Loop Compartment	DEHL*	13.98 @ .141 sec.
6	Loop Compartment	DEHL*	14.62 @ .107 sec.
25	Steamline Pipe Chase	Steamline Double-Ended	12.16 @ .032 sec.
26	Steamline Pipe Chase	Steamline Double-Ended	13.43 @ .035 sec.
28	Upper Pressurizer Cubicle	Spray Line Double-Ended	10.24 @ .364 sec.

*See Subsection 6.2.1.2.1. These are loop compartment design controlling loads. Note that the dynamic (non-static) effects associated with a primary coolant loop break need not be considered to the primary coolant leak-before-break analysis.

B/B-UFSAR

TABLE 6.2-13

SUBCOMPARTMENT MASS AND ENERGY RELEASE RATES (DEHL)

LOOP COMPARTMENT

HOT LEG DE (G) *

INCLUDES 10 PERCENT MARGIN

SUMMARY = BREAK MASS FLOW AND ENERGY FLOW

<u>TIME (S)</u>	<u>MASS FLOW (L3/S)</u>	<u>ENERGY FLOW (BTU/S)</u>	<u>AVG. ENTHALPY (BTU/LB)</u>
.00032	1.0450000E+04	6.7906190E+06	649.82
.00252	9.1702623E+04	5.9379899E+07	647.53
.00502	8.4987827E+04	5.4873596E+07	645.66
.00751	7.6133240E+04	4.9139061E+07	645.44
.01002	7.6118821E+04	4.9171867E+07	645.99
.01251	7.7281712E+04	4.9915878E+07	645.90
.01502	7.7537193E+04	5.0095089E+07	646.08
.01750	7.9167162E+04	5.0521676E+07	646.33
.02001	7.9926657E+04	5.1022108E+07	646.45
.02251	7.9562960E+04	5.1441490E+07	646.55
.02501	8.0132282E+04	5.1816527E+07	646.64
.02751	8.0649564E+04	5.2157182E+07	646.71
.03000	8.1102823E+04	5.2456305E+07	646.79
.03251	8.1512962E+04	5.2727098E+07	646.86
.03503	8.1868122E+04	5.2961052E+07	646.91
.03750	8.2148150E+04	5.3145226E+07	646.94
.04002	8.2347995E+04	5.3277013E+07	646.97
.04251	8.2467109E+04	5.3356941E+07	647.01
.04502	8.2535403E+04	5.3406017E+07	647.07
.04750	8.2600816E+04	5.3456527E+07	647.17
.05002	8.2700645E+04	5.3533389E+07	647.32
.05252	8.2873456E+04	5.3663223E+07	647.53
.05501	8.3177249E+04	5.3883535E+07	647.82
.05752	8.3677092E+04	5.4233441E+07	648.13
.06003	8.4280315E+04	5.4645085E+07	648.37
.06250	8.4884261E+04	5.5851393E+07	648.55
.06502	8.5491246E+04	5.5454646E+07	648.66
.06751	8.6096552E+04	5.5851394E+07	648.71
.07002	8.6667429E+04	5.6222612E+07	648.72
.07255	8.7248811E+04	5.6597392E+07	648.69
.07501	8.7791402E+04	5.6944705E+07	648.64
.07753	8.9334175E+04	5.7289566E+07	648.55
.08001	8.9843083E+04	5.7611027E+07	648.46
.08252	8.9338838E+04	5.7921985E+07	648.34
.08506	8.9807039E+04	5.8213517E+07	648.21
.08756	9.0232328E+04	5.8476779E+07	648.07
.09002	9.0626674E+04	5.8718619E+07	647.92
.09250	9.0979344E+04	5.8932222E+07	647.75
.09501	9.1288544E+04	5.9116696E+07	647.58

* See Section 6.2.1.2.1. These are loop compartment controlling loads. Note that the dynamic (non-static) effects associated with a primary coolant loop break need not be considered due to primary coolant loop leak-before-break analysis.

B/B-UFSAR

TABLE 6.2-13 (Cont'd)

<u>TIME (S)</u>	<u>MASS FLOW (L3/S)</u>	<u>ENERGY FLOW (BTU/S)</u>	<u>AVG. ENTHALPY (BTU/LB)</u>
.09753	9.1537257E+04	5.9260481E+07	647.39
.10038	9.1697001E+04	5.9345622E+07	647.19
.10251	9.1722568E+04	5.9343701E+07	646.99
.10504	9.1546452E+04	5.9210142E+07	646.78
.10758	9.1131493E+04	5.8922018E+07	646.56
.11010	9.1541335E+04	5.8523458E+07	646.37
.11251	8.9909390E+04	5.8100288E+07	646.21
.11505	8.9208432E+04	5.7635842E+07	646.08
.11757	8.8541420E+04	5.7195037E+07	645.97
.12002	8.7897019E+04	5.6759054E+07	645.86
.12255	8.7250220E+04	5.6343084E+07	645.76
.12510	8.6638177E+04	5.5940805E+07	645.68
.12764	8.6078721E+04	5.5573590E+07	645.61
.13016	8.5579263E+04	5.5246187E+07	645.56
.13263	8.5137430E+04	5.4955555E+07	645.49
.13508	8.4734273E+04	5.4690153E+07	645.43
.13762	8.4358080E+04	5.4441957E+07	645.37
.14013	8.4018877E+04	5.4216759E+07	645.29
.14260	8.3702355E+04	5.4005842E+07	645.21
.14502	8.3412103E+04	5.3811719E+07	645.13
.14758	8.3121905E+04	5.3616804E+07	645.04
.15014	8.2847574E+04	5.3431757E+07	644.94
.15256	8.2602551E+04	5.3265857E+07	644.85
.15502	8.2366882E+04	5.3105760E+07	644.75
.15758	8.2141014E+04	5.2951766E+07	644.64
.16009	8.1941352E+04	5.2814957E+07	644.55
.16250	8.1766972E+04	5.2694520E+07	644.45
.16519	8.1614729E+04	5.2587949E+07	644.34
.16754	8.1495818E+04	5.2503181E+07	644.24
.17019	8.1380394E+04	5.2419855E+07	644.13
.17254	8.1293516E+04	5.2355373E+07	644.03
.17519	8.1203618E+04	5.2286828E+07	643.90
.17758	8.1126015E+04	5.2226411E+07	643.77
.18002	8.1047811E+04	5.2164671E+07	643.63
.18270	8.0960694E+04	5.2095655E+07	643.47
.18511	8.0883548E+04	5.2034310E+07	643.32
.18772	8.0802101E+04	5.1969144E+07	643.17
.19014	8.0730574E+04	5.1911322E+07	643.02
.19261	8.0662932E+04	5.1855768E+07	642.87
.19518	8.0599680E+04	5.1802622E+07	642.71
.19762	8.0543649E+04	5.1754893E+07	642.57
.20002	8.0496818E+04	5.1713205E+07	642.43
.20252	8.0450983E+04	5.1571411E+07	642.27
.20503	8.0407924E+04	5.1531247E+07	642.12
.20750	8.0366583E+04	5.1592242E+07	641.96
.21008	8.0321441E+04	5.1549967E+07	641.80
.21271	8.0269049E+04	5.1502514E+07	641.62

B/B-UFSAR

TABLE 6.2-13 (Cont'd)

<u>TIME (S)</u>	<u>MASS FLOW (L3/S)</u>	<u>ENERGY FLOW (BTU/S)</u>	<u>AVG. ENTHALPY (BTU/LB)</u>
.21504	8.0216713E+04	5.1456680E+07	641.47
.21762	8.0149604E+04	5.1399883E+07	641.30
.22021	8.0071203E+04	5.1335773E+07	641.13
.22253	7.9991201E+04	5.1272140E+07	640.97
.22502	7.9895429E+04	5.1197642E+07	640.81
.22772	7.9781335E+04	5.1110519E+07	640.63
.23020	7.9666671E+04	5.1024250E+07	640.47
.23265	7.9546714E+04	5.0935061E+07	640.32
.23510	7.9421278E+04	5.0842576E+07	640.16
.23754	7.9290871E+04	5.0747077E+07	640.01
.24018	7.9146210E+04	5.0641788E+07	639.85
.24255	7.9013973E+04	5.0545907E+07	639.71
.24520	7.8866810E+04	5.0439354E+07	639.55
.24769	7.8729297E+04	5.0339808E+07	639.40
.25022	7.8591574E+04	5.0240058E+07	639.26
.25255	7.8467771E+04	5.0150211E+07	639.12
.25518	7.8332634E+04	5.0051810E+07	638.96
.25761	7.8212276E+04	4.9953817E+07	638.82
.26008	7.8095021E+04	4.9877644E+07	638.68
.26261	7.7980718E+04	4.9793094E+07	638.53
.26519	7.7869684E+04	4.9710360E+07	638.38
.26755	7.7772777E+04	4.9637586E+07	638.24
.27009	7.7672410E+04	4.9561795E+07	638.09
.27256	7.7576236E+04	4.9488687E+07	637.94
.27520	7.7486381E+04	4.9419682E+07	637.79
.27758	7.7405520E+04	4.9356976E+07	637.64
.28017	7.7321833E+04	4.9291403E+07	637.48
.28254	7.7246455E+04	4.9232037E+07	637.34
.28513	7.7166761E+04	4.9168993E+07	637.16
.28770	7.7089602E+04	4.9107700E+07	637.02
.29012	7.7017314E+04	4.9050307E+07	636.87
.29270	7.6941775E+04	4.8990192E+07	636.72
.29504	7.6874009E+04	4.8936219E+07	636.58
.29750	7.6799861E+04	4.8877173E+07	636.42
.30018	7.6725683E+04	4.8818143E+07	636.27
.30255	7.6657763E+04	4.8764156E+07	636.13
.30520	7.6581960E+04	4.8704001E+07	635.97
.30766	7.6511537E+04	4.8648223E+07	635.83
.31020	7.6439107E+04	4.8590967E+07	635.68
.31256	7.6371632E+04	4.8537718E+07	635.55
.31502	7.6301264E+04	4.8482265E+07	635.41
.31776	7.6222240E+04	4.8420259E+07	635.25
.32026	7.6151152E+04	4.8364573E+07	635.11
.32278	7.6078762E+04	4.8307987E+07	634.97
.32500	7.6015001E+04	4.8258290E+07	634.85
.32751	7.5943429E+04	4.8202571E+07	634.72
.33003	7.5871648E+04	4.8146770E+07	634.58

B/B-UFSAR

TABLE 6.2-13 (Cont'd)

<u>TIME (S)</u>	<u>MASS FLOW (L3/S)</u>	<u>ENERGY FLOW (BTU/S)</u>	<u>AVG. ENTHALPY (BTU/LB)</u>
.33255	7.5800063E+04	4.8091216E+07	634.45
.33507	7.5728692E+04	4.8035901E+07	634.32
.33759	7.5657336E+04	4.7980673E+07	634.18
.34012	7.5586039E+04	4.7925580E+07	634.05
.34264	7.5514831E+04	4.7870648E+07	633.92
.34517	7.5443644E+04	4.7815826E+07	633.80
.34770	7.5372478E+04	4.7761116E+07	633.67
.35022	7.5301372E+04	4.7706550E+07	633.54
.35275	7.5230345E+04	4.7652137E+07	633.42
.35528	7.5159424E+04	4.7597892E+07	633.29
.35753	7.5096514E+04	4.7549840E+07	633.18
.36006	7.5025937E+04	4.7495993E+07	633.06
.36260	7.4955633E+04	4.7442404E+07	632.94
.36514	7.4885686E+04	4.7389115E+07	632.82
.36769	7.4816195E+04	4.7336176E+07	632.70
.37026	7.4747270E+04	4.7283643E+07	632.58
.37255	7.4686576E+04	4.7237335E+07	632.47
.37515	7.4619085E+04	4.7185755E+07	632.36
.37777	7.4552567E+04	4.7134782E+07	632.24
.38012	7.4494234E+04	4.7089978E+07	632.13
.38280	7.4429957E+04	4.7040302E+07	632.01
.38521	7.4373927E+04	4.6996807E+07	631.90
.38766	7.4319097E+04	4.6953985E+07	631.79
.39014	7.4265592E+04	4.6911901E+07	631.68
.39257	7.4213490E+04	4.6870577E+07	631.56
.39525	7.4162848E+04	4.6830030E+07	631.45
.39755	7.4119771E+04	4.6795197E+07	631.35
.40024	7.4071956E+04	4.6756110E+07	631.23
.40263	7.4031324E+04	4.6722508E+07	631.12
.40505	7.3992265E+04	4.6689869E+07	631.01
.40754	7.3953634E+04	4.6657181E+07	630.90
.41008	7.3915834E+04	4.6624898E+07	630.78
.41265	7.3878877E+04	4.6593031E+07	630.67
.41522	7.3842520E+04	4.6561488E+07	630.55
.41759	7.3809273E+04	4.6532683E+07	630.44
.42016	7.3773743E+04	4.6501827E+07	630.33
.42263	7.3739360E+04	4.6472025E+07	630.22
.42509	7.3705024E+04	4.6442349E+07	630.11
.42767	7.3668412E+04	4.6410792E+07	630.00
.43024	7.3630468E+04	4.6378431E+07	629.88
.43281	7.3591538E+04	4.6345540E+07	629.77
.43510	7.3555847E+04	4.6315678E+07	629.67
.43779	7.3512262E+04	4.6279600E+07	629.55
.44015	7.3471929E+04	4.6246663E+07	629.45
.44263	7.3427628E+04	4.6211068E+07	629.34
.44503	7.3383680E+04	4.6176106E+07	629.24
.44776	7.3331978E+04	4.6135356E+07	629.13

B/B-UFSAR

TABLE 6.2-13 (Cont'd)

<u>TIME (S)</u>	<u>MASS FLOW (L3/S)</u>	<u>ENERGY FLOW (BTU/S)</u>	<u>AVG. ENTHALPY (BTU/LB)</u>
.45031	7.3282141E+04	4.6096379E+07	629.03
.45260	7.3235561E+04	4.6060263E+07	628.93
.45518	7.3182092E+04	4.6019183E+07	628.83
.45779	7.3126951E+04	4.5977094E+07	628.73
.46006	7.3077974E+04	4.5939970E+07	628.64
.46262	7.3022010E+04	4.5897808E+07	628.55
.46518	7.2965695E+04	4.5855565E+07	628.45
.46775	7.2909064E+04	4.5813244E+07	628.36
.47030	7.2852601E+04	4.5771172E+07	628.27
.47255	7.2803434E+04	4.5734594E+07	628.19
.47512	7.2747555E+04	4.5693055E+07	628.10
.47771	7.2692239E+04	4.5651939E+07	628.02
.48032	7.2637685E+04	4.5611357E+07	627.93
.48262	7.2590658E+04	4.5577631E+07	627.85
.48527	7.2537845E+04	4.5536867E+07	627.77
.48762	7.2492558E+04	4.5502934E+07	627.69
.49034	7.2441942E+04	4.5464857E+07	627.60
.49274	7.2398700E+04	4.5432173E+07	627.53
.49517	7.2356762E+04	4.5400321E+07	627.45
.49765	7.2315453E+04	4.5368758E+07	627.37
.50024	7.2273965E+04	4.5337058E+07	627.29
.51032	7.2127491E+04	4.5222834E+07	626.98
.52016	7.2001732E+04	4.5122139E+07	626.68
.53003	7.1882619E+04	4.5026374E+07	626.39
.54020	7.1757488E+04	4.4926891E+07	626.09
.55004	7.1625934E+04	4.4825006E+07	625.82
.56004	7.1478064E+04	4.4713790E+07	625.56
.57018	7.1315949E+04	4.4594769E+07	625.31
.58018	7.1151872E+04	4.4476280E+07	625.09
.59033	7.0991087E+04	4.4360991E+07	624.88
.60028	7.0846250E+04	4.4257250E+07	624.69
.61006	7.0720517E+04	4.4166727E+07	624.52
.62028	7.0603826E+04	4.4081922E+07	624.36
.63028	7.0497398E+04	4.4004179E+07	624.20
.64037	7.0390156E+04	4.3926138E+07	624.04
.65032	7.0279762E+04	4.3846588E+07	623.89
.66003	7.0166429E+04	4.3766038E+07	623.75
.67035	7.0040619E+04	4.3677892E+07	623.61
.68020	6.9916543E+04	4.3592177E+07	623.49
.69008	6.9789328E+04	4.5305404E+07	623.38
.70037	6.9655953E+04	4.3415515E+07	623.29
.71029	6.9527357E+04	4.3329755E+07	623.20
.72021	6.9402132E+04	4.3247000E+07	623.14
.73010	6.9276026E+04	4.3164872E+07	623.09
.74021	6.9149644E+04	4.3082727E+07	623.04
.75002	6.9029488E+04	4.3004148E+07	622.98
.76000	6.8906029E+04	4.2924081E+07	622.94

B/B-UFSAR

TABLE 6.2-13 (Cont'd)

<u>TIME (S)</u>	<u>MASS FLOW (L3/S)</u>	<u>ENERGY FLOW (BTU/S)</u>	<u>AVG. ENTHALPY (BTU/LB)</u>
.77025	6.87804105+04	4.2843095E+07	622.90
.78006	6.8662759E+04	4.2767283E+07	622.86
.79033	6.8541617E+04	4.2689920E+07	622.83
.80016	6.8426399E+04	4.2616761E+07	622.81
.81028	6.8307192E+04	4.2541464E+07	622.80
.82032	6.8186958E+04	4.2455921E+07	622.79
.83026	6.8064929E+04	4.2389625E+07	622.78
.84010	6.7940977E+04	4.2312479E+07	622.78
.85016	6.7811183E+04	4.2232057E+07	622.79
.86014	6.7680887E+04	4.2151725E+07	622.80
.87013	6.7551641E+04	4.2072496E+07	622.82
.88014	6.7424638E+04	4.1995093E+07	622.84
.89016	6.7300109E+04	4.1919559E+07	622.88
.90014	6.7177304E+04	4.1845265E+07	622.91
.91001	6.7055021E+04	4.1771327E+07	622.94
.92008	6.6928373E+04	4.1694733E+07	622.98
.93002	6.6801748E+04	4.1618209E+07	623.01
.94022	6.6672846E+04	4.1540604E+07	623.05
.95016	6.6552609E+04	4.1468865E+07	623.10
.96032	6.6439870E+04	4.1402573E+07	623.16
.97003	6.6342067E+04	4.1346011E+07	623.22
.98019	6.6247034E+04	4.1291775E+07	623.30
.99034	6.6155388E+04	4.1239880E+07	623.38
1.00009	6.6067983E+04	4.1190608E+07	623.46
1.05030	6.5603486E+04	4.0931086E+07	623.92
1.10009	6.5077242E+04	4.0636301E+07	624.43
1.15005	6.4460076E+04	4.0283981E+07	624.94
1.20022	6.3921631E+04	3.9986030E+07	625.55
1.25009	6.3380665E+04	3.9683232E+07	626.11
1.30021	6.2889985E+04	3.9411562E+07	626.67
1.35018	6.2380042E+04	3.9124505E+07	627.20
1.40030	6.1869308E+04	3.8836200E+07	627.71
1.45011	6.1327869E+04	3.8526052E+07	628.20
1.50013	6.0753843E+04	3.8194367E+07	628.67
1.55010	6.0152311E+04	3.7844382E+07	629.14
1.60014	5.9508198E+04	3.7465703E+07	629.59
1.65001	5.8867275E+04	3.7090366E+07	630.07
1.70007	5.8227768E+04	3.6717784E+07	630.59
1.75010	5.7570888E+04	3.6335240E+07	631.14
1.80003	5.6924962E+04	3.5962142E+07	631.75
1.85003	5.6285021E+04	3.5594964E+07	632.41
1.90028	5.5632266E+04	3.5220597E+07	633.10
1.95028	5.4981660E+04	3.4848198E+07	633.81
2.00032	5.4354119E+04	3.4491783E+07	634.58

B/B-UFSAR

TABLE 6.2-14

SUBCOMPARTMENT MASS AND ENERGY RELEASE RATES (DECL)

LOOP COMPARTMENT

COLD LEG DE (G) *

INCLUDES 10 PERCENT MARGIN

SUMMARY = BREAK MASS FLOW AND ENERGY FLOW

<u>TIME (S)</u>	<u>MASS FLOW (L3/S)</u>	<u>ENERGY FLOW (BTU/S)</u>	<u>AVG. ENTHALPY (BTU/LB)</u>
.00032	1.0450000E+04	5.8364295E+06	558.51
.00252	6.5293399E+04	3.6149158E+07	553.64
.00501	6.9050997E+04	3.8213077E+07	553.40
.00751	6.6248743E+04	3.6637286E+07	553.03
.01002	6.2701722E+04	3.4658711E+07	552.76
.01251	6.0415941E+04	3.3398156E+07	552.80
.01501	6.0048462E+04	3.3209641E+07	553.05
.01754	6.0804842E+04	3.4637961E+07	553.21
.02002	6.1534934E+04	3.4045517E+07	553.27
.02256	6.2099988E+04	3.4360624E+07	553.31
.02501	6.2519500E+04	3.4596249E+07	553.37
.02753	6.2922332E+04	3.4823718E+07	553.44
.03000	6.3303899E+04	3.5039501E+07	553.51
.03253	6.3681171E+04	3.5252837E+07	553.58
.03502	6.4052068E+04	3.5461821E+07	553.64
.03751	6.4405685E+04	3.5661226E+07	553.70
.04001	6.4757004E+04	3.5862976E+07	553.81
.04250	6.5173289E+04	3.6102591E+07	553.95
.04502	6.5637870E+04	3.6368066E+07	554.07
.04750	6.6338671E+04	3.6789796E+07	554.58
.05001	6.7982945E+04	3.7710906E+07	554.71
.05252	6.9398632E+04	4.8500911E+07	554.78
.05503	8.4757420E+04	5.7836613E+07	554.96
.05751	9.1285190E+04	5.0710377E+07	555.52
.06001	9.2962792E+04	5.1639617E+07	555.49
.06250	9.1170263E+04	5.0616264E+07	555.18
.06503	9.2737233E+04	5.1491742E+07	555.24
.06753	9.3489060E+04	5.1913091E+07	555.29
.07005	9.4737866E+04	5.2608120E+07	555.30
.07256	9.4936403E+04	5.2716009E+07	555.28
.07501	9.5012243E+04	5.2752588E+07	555.22
.07751	9.5219511E+04	5.2873399E+07	555.28
.08002	9.6097778E+04	5.3368064E+07	555.35
.08257	9.6796106E+04	5.3759464E+07	555.39
.08502	9.7062220E+04	5.3907457E+07	555.39
.08750	9.7452854E+04	5.4127827E+07	555.43
.09034	9.7929979E+04	5.4396834E+07	555.47
.09256	9.8302034E+04	5.4604677E+07	555.48
.09504	9.8468322E+04	5.4697076E+07	555.48

* See Section 6.2.1.2.1. These are loop compartment design controlling loads. Note that the dynamic (non-static) effects associated with a primary coolant loop break need not be considered due to primary coolant loop leak-before-break analysis.

B/B-UFSAR

TABLE 6.2-14 (Cont'd)

<u>TIME (S)</u>	<u>MASS FLOW (L3/S)</u>	<u>ENERGY FLOW (BTU/S)</u>	<u>AVG. ENTHALPY (BTU/LB)</u>
.09751	9.8676819E+04	5.4813954E+07	555.49
.10002	9.8894161E+04	5.4935727E+07	555.50
.10258	9.9016455E+04	5.5003384E+07	555.50
.10506	9.9116068E+04	5.5058823E+07	555.50
.10762	9.9229045E+04	5.5121624E+07	555.50
.11009	9.9279361E+04	5.5148793E+07	555.49
.11256	9.9290025E+04	5.5154087E+07	555.48
.11507	9.9390184E+04	5.5210636E+07	555.49
.11755	9.9582207E+04	5.5319088E+07	555.51
.12009	9.9790673E+04	5.5436501E+07	555.53
.12251	9.9992890E+04	5.5550409E+07	555.54
.12506	1.0025231E+05	5.5696726E+07	555.57
.12751	1.0054998E+05	5.5864690E+07	555.59
.13011	1.0086495E+05	5.6042365E+07	555.62
.13258	1.0112191E+05	5.6187418E+07	555.64
.13505	1.0135538E+05	5.6318896E+07	555.66
.13754	1.0156197E+05	5.6435857E+07	555.68
.14012	1.0172003E+05	5.6525463E+07	555.70
.14255	1.0182024E+05	5.6582663E+07	555.71
.14510	1.0185915E+05	5.6605779E+07	555.73
.14755	1.0185191E+05	5.6602976E+07	555.74
.15005	1.0181196E+05	5.6582199E+07	555.75
.15259	1.0175793E+05	5.6553815E+07	555.77
.15503	1.0172085E+05	5.6535270E+07	555.79
.15765	1.0171597E+05	5.6535329E+07	555.82
.16017	1.0174698E+05	5.6555427E+07	555.84
.16259	1.0180477E+05	5.6590450E+07	555.87
.16502	1.0188002E+05	5.6634740E+07	555.90
.16754	1.0197234E+05	5.6688459E+07	555.92
.17013	1.0205675E+05	5.6737224E+07	555.94
.17252	1.0212086E+05	5.6774011E+07	555.95
.17500	1.0216666E+05	5.6800249E+07	555.96
.17753	1.0219290E+05	5.6815191E+07	555.96
.18002	1.0219181E+05	5.6814441E+07	555.96
.18264	1.0214929E+05	5.6790099E+07	555.95
.18505	1.0206855E+05	5.6744146E+07	555.94
.18756	1.0193973E+05	5.6671148E+07	555.93
.19007	1.0177028E+05	5.6575210E+07	555.91
.19261	1.0158053E+05	5.6458077E+07	555.89
.19506	1.0136546E+05	5.6346986E+07	555.88
.19762	1.0116089E+05	5.6231928E+07	555.87
.20014	1.0098518E+05	5.6133616E+07	555.86
.20251	1.0085093E+05	5.6006190E+07	555.86
.20504	1.0075617E+05	5.6058642E+07	555.86
.20760	1.0070154E+05	5.5976418E+07	555.86
.21000	1.0069211E+05	5.5972068E+07	555.87
.21253	1.0071815E+05	5.5987766E+07	555.89

B/B-UFSAR

TABLE 6.2-14 (Cont'd)

<u>TIME (S)</u>	<u>MASS FLOW (L3/S)</u>	<u>ENERGY FLOW (BTU/S)</u>	<u>AVG. ENTHALPY (BTU/LB)</u>
.21508	1.0077350E+05	5.6019827E+07	555.90
.21766	1.0084813E+05	5.6062595E+07	555.91
.22002	1.0092308E+05	5.6105147E+07	555.92
.22256	1.0100710E+05	5.6152669E+07	555.93
.22517	1.0108645E+05	5.6197399E+07	555.93
.22766	1.0116008E+05	5.6238720E+07	555.94
.23007	1.0122343E+05	5.6274239E+07	555.94
.23268	1.0128341E+05	5.6307706E+07	555.94
.23503	1.0133802E+05	5.6338198E+07	555.94
.23766	1.0139493E+05	5.6369993E+07	555.94
.24004	1.0145018E+05	5.6400808E+07	555.95
.24263	1.0151245E+05	5.6435680E+07	555.95
.24520	1.0157079E+05	5.6468279E+07	555.95
.24762	1.0162722E+05	5.6499819E+07	555.95
.25008	1.0167322E+05	5.6525539E+07	555.95
.25257	1.0171015E+05	5.6546041E+07	555.95
.25506	1.0173048E+05	5.6557262E+07	555.95
.25768	1.0172963E+05	5.6556483E+07	555.95
.26005	1.0170843E+05	5.6544253E+07	555.94
.26258	1.0165900E+05	5.6516060E+07	555.94
.26513	1.0158144E+05	5.6472132E+07	555.93
.26767	1.0147922E+05	5.6414442E+07	555.92
.27002	1.0136204E+05	5.6348377E+07	555.91
.27251	1.0121949E+05	5.6268134E+07	555.90
.27512	1.0105313E+05	5.6174591E+07	555.89
.27754	1.0089788E+05	5.6087280E+07	555.88
.28009	1.0072300E+05	5.5989406E+07	555.88
.28252	1.0056402E+05	5.5900296E+07	555.87
.28517	1.0040775E+05	5.5812918E+07	555.86
.28751	1.0027094E+05	5.5736496E+07	555.86
.29012	1.0015486E+05	5.5671910E+07	555.86
.29265	1.0009684E+05	5.5640472E+07	555.87
.29513	1.0011182E+05	5.5650319E+07	555.88
.29768	1.0016733E+05	5.5682826E+07	555.90
.30012	1.0020994E+05	5.5707478E+07	555.91
.30250	1.0023137E+05	5.5719871E+07	555.91
.30505	1.0025572E+05	5.5733973E+07	555.92
.30773	1.0029144E+05	5.5754487E+07	555.92
.31015	1.0031138E+05	5.5765822E+07	555.93
.31253	1.0031119E+05	5.5765662E+07	555.93
.31512	1.0030749E+05	5.5763671E+07	555.93
.31759	1.0031822E+05	5.5769997E+07	555.93
.32008	1.0034212E+05	5.5783805E+07	555.94
.32264	1.0037469E+05	5.5802485E+07	555.94
.32507	1.0041691E+05	5.5826655E+07	555.95
.32763	1.0047305E+05	5.5858690E+07	555.96
.33003	1.0054114E+05	5.5897475E+07	555.97

B/B-UFSAR

TABLE 6.2-14 (Cont'd)

<u>TIME (S)</u>	<u>MASS FLOW (L3/S)</u>	<u>ENERGY FLOW (BTU/S)</u>	<u>AVG. ENTHALPY (BTU/LB)</u>
.33253	1.0061897E+05	5.5941692E+07	555.98
.33520	1.0070993E+05	5.5993274E+07	555.99
.33753	1.0079164E+05	5.6039530E+07	555.99
.34000	1.0086973E+05	5.6083588E+07	556.00
.34251	1.0093668E+05	5.6121262E+07	556.00
.34513	1.0098898E+05	5.6150556E+07	556.01
.34756	1.0102134E+05	5.6158561E+07	556.01
.35003	1.0103349E+05	5.6175072E+07	556.00
.35263	1.0102007E+05	5.6167084E+07	556.00
.35511	1.0098126E+05	5.6144779E+07	555.99
.35756	1.0092594E+05	5.6113230E+07	555.98
.36012	1.0085319E+05	5.6071917E+07	555.98
.36259	1.0077946E+05	5.6030196E+07	555.97
.36508	1.0069881E+05	5.5984654E+07	555.96
.36752	1.0062053E+05	5.5940534E+07	555.96
.37012	1.0053621E+05	5.5893013E+07	555.95
.37257	1.0045506E+05	5.5847393E+07	555.94
.37511	1.0036841E+05	5.5798651E+07	555.94
.37751	1.0027592E+05	5.5746557E+07	555.93
.38017	1.0016478E+05	5.5683952E+07	555.92
.38251	1.0005392E+05	5.5621474E+07	555.91
.38506	9.9925528E+04	5.5549166E+07	555.91
.38752	9.9790289E+04	5.5473083E+07	555.90
.39002	9.9648674E+04	5.5393348E+07	555.89
.39268	9.9499183E+04	5.5309571E+07	555.88
.39507	9.9360111E+04	5.5231564E+07	555.87
.39752	9.9234440E+04	5.5161163E+07	555.87
.40013	9.9105290E+04	5.5089028E+07	555.86
.40252	9.9002837E+04	5.5031891E+07	555.86
.40502	9.8927142E+04	5.4989977E+07	555.86
.40762	9.8867421E+04	5.4957141E+07	555.87
.41012	9.8835955E+04	5.4940258E+07	555.87
.41266	9.8826302E+04	5.4935716E+07	555.88
.41504	9.8834809E+04	5.4941391E+07	555.89
.41752	9.8856432E+04	5.4954441E+07	555.90
.42012	9.8885825E+04	5.4971714E+07	555.91
.42254	9.8913923E+04	5.4988105E+07	555.92
.42511	9.8940187E+04	5.5003432E+07	555.93
.42770	9.8959221E+04	5.5014980E+07	555.93
.43007	9.8974144E+04	5.5023391E+07	555.94
.43260	9.8984293E+04	5.5029513E+07	555.94
.43508	9.8993498E+04	5.5035154E+07	555.95
.43755	9.9002597E+04	5.5040727E+07	555.95
.44003	9.9013620E+04	5.5047449E+07	555.96
.44267	9.9026937E+04	5.5055425E+07	555.96
.44501	9.9041839E+04	5.5064305E+07	555.97
.44766	9.9058368E+04	5.5074106E+07	555.98

B/B-UFSAR

TABLE 6.2-14 (Cont'd)

<u>TIME (S)</u>	<u>MASS FLOW (L3/S)</u>	<u>ENERGY FLOW (BTU/S)</u>	<u>AVG. ENTHALPY (BTU/LB)</u>
.45011	9.9074658E+04	5.5083755E+07	555.98
.45258	9.9088119E+04	5.5091746E+07	555.99
.45501	9.9098885E+04	5.5098224E+07	555.99
.45752	9.9103054E+04	5.5100920E+07	556.00
.46004	9.9098918E+04	5.5098912E+07	556.00
.46255	9.9084833E+04	5.5091252E+07	556.00
.46505	9.9058050E+04	5.5076388E+07	556.00
.46758	9.9021749E+04	5.5056210E+07	556.00
.47005	9.8972631E+04	5.5028786E+07	556.00
.47256	9.8918429E+04	5.4998522E+07	556.00
.47503	9.8855024E+04	5.4963088E+07	556.00
.47759	9.8787595E+04	5.4925458E+07	556.00
.48017	9.8720201E+04	5.4887918E+07	555.99
.48257	9.8654501E+04	5.4851348E+07	555.99
.48510	9.8590296E+04	5.4815697E+07	555.99
.48751	9.8529026E+04	5.4781698E+07	556.00
.49014	9.8466506E+04	5.4747106E+07	556.00
.49257	9.8411679E+04	5.4716830E+07	556.00
.49511	9.8356708E+04	5.4686497E+07	556.00
.49763	9.8305497E+04	5.4658299E+07	556.00
.50010	9.8256310E+04	5.4631275E+07	556.01
.51013	9.8093375E+04	5.4542483E+07	556.03
.52002	9.8016719E+04	5.4502720E+07	556.06
.53001	9.8030509E+04	5.4514014E+07	556.09
.54004	9.8049077E+04	5.4527561E+07	556.13
.55001	9.7970636E+04	5.4486026E+07	556.15
.56012	9.7807326E+04	5.4396893E+07	556.16
.57008	9.7621367E+04	5.4295392E+07	556.18
.58009	9.7425011E+04	5.4188258E+07	556.20
.59015	9.7213809E+04	5.4073029E+07	556.23
.60006	9.7034190E+04	5.3975992E+07	556.26
.61001	9.6922063E+04	5.3917290E+07	556.30
.62011	9.6856360E+04	5.3884870E+07	556.34
.63010	9.6799204E+04	5.3857102E+07	556.38
.64021	9.6722714E+04	5.3818597E+07	556.42
.65006	9.6605719E+04	5.3757220E+07	556.46
.66009	9.6429082E+04	5.3662426E+07	556.50
.67007	9.6217883E+04	5.3548485E+07	556.53
.68012	9.6029601E+04	5.3448009E+07	556.58
.69020	9.5881221E+04	5.3370286E+07	556.63
.70010	9.5749448E+04	5.3301953E+07	556.68
.71007	9.5613630E+04	5.3231285E+07	556.73
.72011	9.5479138E+04	5.3161491E+07	556.79
.73007	9.5343769E+04	5.3091220E+07	556.84
.74002	9.5190880E+04	5.3011203E+07	556.89
.75005	9.5014279E+04	5.2918060E+07	556.95
.76009	9.4826835E+04	5.2818991E+07	557.00

B/B-UFSAR

TABLE 6.2-14 (Cont'd)

<u>TIME (S)</u>	<u>MASS FLOW (L3/S)</u>	<u>ENERGY FLOW (BTU/S)</u>	<u>AVG. ENTHALPY (BTU/LB)</u>
.77013	9.4638591E+04	5.2719726E+07	557.06
.78013	9.4563697E+04	5.2684627E+07	557.13
.79001	9.4375101E+04	5.2584744E+07	557.19
.80003	9.4211962E+04	5.2500157E+07	557.26
.81015	9.4041285E+04	5.2411686E+07	557.33
.82004	9.38676975E+04	5.2321578E+07	557.40
.83020	9.3684217E+04	5.2225952E+07	557.47
.84010	9.3488271E+04	5.2123117E+07	557.54
.85000	9.3277468E+04	5.2011889E+07	557.60
.86003	9.3057931E+04	5.1896026E+07	557.67
.87007	9.2847260E+04	5.1785318E+07	557.75
.88019	9.2644308E+04	5.1679101E+07	557.82
.89005	9.2443153E+04	5.1574072E+07	557.90
.90012	9.2237350E+04	5.1467038E+07	557.98
.91005	9.2035255E+04	5.1362308E+07	558.07
.92012	9.2005625E+04	5.1355698E+07	558.18
.93003	9.2063920E+04	5.1396925E+07	558.27
.94012	9.2101294E+04	5.1426245E+07	558.37
.95007	9.2101938E+04	5.1435012E+07	558.48
.96012	9.2093904E+04	5.1438991E+07	558.55
.97010	9.1974451E+04	5.1379998E+07	558.63
.98005	9.1799443E+04	5.1290091E+07	558.72
.99024	9.16610575E+04	5.1221516E+07	558.81
1.00003	9.1507811E+04	5.1144439E+07	558.91
1.05006	9.0810290E+04	5.0798705E+07	559.39
1.10003	9.0191154E+04	5.0498277E+07	559.90
1.15007	8.9579390E+04	5.0202720E+07	560.43
1.20007	8.8514882E+04	4.9654038E+07	560.97
1.25021	8.7416588E+04	4.9086975E+07	561.53
1.30017	8.6243958E+04	4.8479041E+07	562.12
1.35011	8.5068988E+04	4.7869143E+07	562.71
1.40001	8.4077437E+04	4.7360420E+07	563.30
1.45012	8.3078233E+04	4.6848713E+07	563.91
1.50011	8.2313650E+04	4.6467814E+07	564.52
1.55011	8.1609508E+04	4.6119548E+07	565.12
1.60004	8.0867656E+04	4.5748266E+07	565.72
1.65019	8.0095162E+04	4.5354842E+07	566.26
1.70007	7.9135253E+04	4.4854435E+07	566.81
1.75007	7.8073107E+04	4.4285394E+07	567.23
1.80000	7.6871315E+04	4.3630008E+07	567.57
1.85008	7.5758761E+04	4.3019588E+07	567.85
1.90011	7.4603834E+04	4.2383078E+07	568.11
1.95006	7.3533736E+04	4.1794583E+07	568.37
2.00012	7.2586063E+04	4.1273341E+07	568.61

B/B-UFSAR

TABLE 6.2-15

SUBCOMPARTMENT MASS AND ENERGY RELEASE RATES
(PRESSURIZER SPRAY LINE)

PRESSURIZER
 PRESSURIZER SPRAY LINE BREAK
 INCLUDES 10 PERCENT MARGIN
 SUMMARY = BREAK MASS FLOW AND ENERGY FLOW

<u>TIME (S)</u>	<u>MASS FLOW (LB/S)</u>	<u>ENERGY FLOW (BTU/S)</u>	<u>AVG. ENTHALPY (BTU/LB)</u>
.00000	0.	0.	0.00
.00251	5.5520269E+03	3.4074591E+06	613.73
.00502	5.7566695E+03	3.5214197E+06	611.71
.00751	5.6923083E+03	3.4814317E+06	611.60
.01002	5.6156477E+03	3.4348228E+06	611.65
.01251	5.5820416E+03	3.4132128E+06	611.46
.01502	5.6059056E+03	3.4246446E+06	610.90
.01755	5.9216506E+03	3.6028096E+06	608.41
.02003	6.0459291E+03	3.6722760E+06	607.30
.02255	6.0807799E+03	3.6897530E+06	606.79
.02505	6.0942687E+03	3.6961327E+06	606.49
.02754	6.2322326E+03	3.7737113E+06	605.52
.03004	6.3772227E+03	3.8554807E+06	604.57
.03259	6.4620881E+03	3.9026378E+06	603.93
.03507	6.4752834E+03	3.9088990E+06	603.66
.03753	6.5151813E+03	3.9305146E+06	603.29
.04002	6.5143568E+03	3.9287741E+06	603.09
.04251	6.4438043E+03	3.8870628E+06	603.22
.04511	6.3427181E+03	3.8281043E+06	603.54
.04763	6.2773775E+03	3.7899141E+06	603.74
.05005	6.2551735E+03	3.7764886E+06	603.74
.05263	6.2524046E+03	3.7741758E+06	603.64
.05518	6.2658754E+03	3.7818297E+06	603.46
.05760	6.2974621E+03	3.7987461E+06	603.22
.06003	6.3249883E+03	3.8139254E+06	602.99
.06259	6.3350379E+03	3.8191169E+06	602.86
.06519	6.3288577E+03	3.8150521E+06	602.80
.06750	6.3276385E+03	3.8139641E+06	602.75
.07006	6.3455081E+03	3.8238003E+06	602.60
.07250	6.3665132E+03	3.8354407E+06	602.44
.07503	6.3688606E+03	3.8363851E+06	602.37
.07763	6.3404989E+03	3.8197353E+06	602.43
.08003	6.2872107E+03	3.7888759E+06	602.63
.08254	6.2175863E+03	3.7487047E+06	602.92
.08512	6.1352700E+03	3.7014579E+06	603.31
.08753	6.0708749E+03	3.6645461E+06	603.63
.09001	6.0409120E+03	3.6473208E+06	603.77
.09253	6.0539679E+03	3.6546606E+06	603.68
.09508	6.1075851E+03	3.6851210E+06	603.37

B/B-UFSAR

TABLE 6.2-15 (Cont'd)

<u>TIME (S)</u>	<u>MASS FLOW (LB/S)</u>	<u>ENERGY FLOW (BTU/S)</u>	<u>AVG. ENTHALPY (BTU/LB)</u>
.09759	6.1876085E+03	3.7306914E+06	602.93
.10002	6.2735718E+03	3.7796317E+06	602.47
.10257	6.3664980E+03	3.8325765E+06	601.99
.10507	6.4429047E+03	3.8761465E+06	601.61
.10758	6.4965895E+03	3.9067176E+06	601.35
.11001	6.5270618E+03	3.9240262E+06	601.19
.11253	6.5344748E+03	3.9281326E+06	601.14
.11510	6.5204882E+03	3.9199857E+06	601.18
.11761	6.4843044E+03	3.8991158E+06	601.32
.12009	6.4325725E+03	3.8693579E+06	601.53
.12255	6.3726344E+03	3.8349813E+06	601.79
.12518	6.3034597E+03	3.7953523E+06	602.11
.12761	6.2383094E+03	3.7580645E+06	602.42
.13012	6.1820566E+03	3.7258948E+06	602.70
.13264	6.1395327E+03	3.7015958E+06	602.91
.13504	6.1127110E+03	3.6862746E+06	603.05
.13755	6.0998879E+03	3.6789327E+06	603.11
.14010	6.0988357E+03	3.6783086E+06	603.12
.14257	6.1080626E+03	3.6835439E+06	603.06
.14510	6.1240390E+03	3.6926378E+06	602.97
.14758	6.1442581E+03	3.7041585E+06	602.87
.16011	6.1657410E+03	3.7169743E+06	602.75
.15260	6.1857163E+03	3.7283579E+06	602.64
.15502	6.1992384E+03	3.7354879E+06	602.57
.15755	6.2031636E+03	3.7377038E+06	602.55
.16011	6.1939722E+03	3.7324198E+06	602.59
.16265	6.1745723E+03	3.7213319E+06	602.69
.16510	6.1423746E+03	3.7029436E+06	602.85
.16751	6.1097626E+03	3.6843379E+06	603.02
.17014	6.0750772E+03	3.6645786E+06	603.22
.17253	6.0482471E+03	3.6492888E+06	603.36
.17512	6.0289841E+03	3.6383136E+06	603.47
.17760	6.0193184E+03	3.6328038E+06	603.52
.18008	6.0197962E+03	3.6330808E+06	603.52
.18258	6.0276833E+03	3.6375701E+06	603.48
.18501	6.0400469E+03	3.6446001E+06	603.41
.18766	6.0528858E+03	3.6518945E+06	603.33
.19013	6.0646210E+03	3.6585557E+06	603.26
.19254	6.0708106E+03	3.6620600E+06	603.22
.19500	6.0717703E+03	3.6625777E+06	603.21
.19754	6.0668335E+03	3.6597328E+06	603.24
.20010	6.0570812E+03	3.6541472E+06	603.29
.20274	6.0452208E+03	3.6473601E+06	603.35
.20509	6.0330499E+03	3.6404113E+06	603.41
.20760	6.0241617E+03	3.6353420E+06	603.46
.21005	6.0191035E+03	3.6324522E+06	603.49
.21254	6.0197127E+03	3.6327939E+06	603.48

B/B-UFSAR

TABLE 6.2-15 (Cont'd)

<u>TIME (S)</u>	<u>MASS FLOW (LB/S)</u>	<u>ENERGY FLOW (BTU/S)</u>	<u>AVG. ENTHALPY (BTU/LB)</u>
.21510	6.0257956E+03	3.6362513E+06	603.45
.21754	6.0357699E+03	3.6419285E+06	603.39
.22016	6.0480859E+03	3.6489364E+06	603.32
.22256	6.0625560E+03	3.6571731E+06	603.24
.22504	6.0749929E+03	3.6642500E+06	603.17
.22753	6.0866417E+03	3.6708838E+06	603.10
.23007	6.0951080E+03	3.6757012E+06	603.06
.23259	6.1001899E+03	3.6785898E+06	603.03
.23508	6.1011008E+03	3.6791040E+06	603.02
.23753	6.0973306E+03	3.6769487E+06	603.04
.24023	6.0876426E+03	3.6714129E+06	603.09
.24255	6.0753055E+03	3.6643848E+06	603.16
.24503	6.0554102E+03	3.6536132E+06	603.26
.24751	6.0364519E+03	3.6422456E+06	603.38
.25009	6.0184816E+03	3.6320047E+06	603.48
.25280	6.0028077E+03	3.6230838E+06	603.56
.25504	5.9931687E+03	3.6175960E+06	603.62
.25759	5.9900445E+03	3.6158252E+06	603.64
.26004	5.9938317E+03	3.6179873E+06	603.62
.26255	6.0039391E+03	3.6237539E+06	603.56
.25501	6.0188653E+03	3.6322491E+06	603.48
.26759	6.0373297E+03	3.6427624E+06	603.37
.27011	6.0551031E+03	3.6528848E+06	603.27
.27258	6.0711548E+03	3.6620230E+06	603.18
.27506	6.0821145E+03	3.6682550E+06	603.12
.27752	6.0879002E+03	3.6715416E+06	603.09
.28003	6.0867031E+03	3.6708478E+06	603.09
.28252	6.0784821E+03	3.6661507E+06	603.14
.28504	6.0651856E+03	3.6585621E+06	603.21
.28754	6.0434821E+03	3.6461959E+06	603.33
.29006	6.0196102E+03	3.6325934E+06	603.46
.29255	5.9947341E+03	3.6184236E+06	603.60
.29520	5.9887892E+03	3.6036635E+06	603.75
.29758	5.9450244E+03	3.5901412E+06	603.89
.30004	5.9252478E+03	3.5788953E+06	604.01
.30284	5.9052411E+03	3.5675125E+06	604.13
.30504	5.8913813E+03	3.5596397E+06	604.21
.30760	5.8782215E+03	3.5521680E+06	604.29
.31001	5.8700234E+03	3.5475147E+06	604.34
.31256	5.8639105E+03	3.5440436E+06	604.33
.31501	5.8607978E+03	3.5422734E+06	604.40
.31753	5.8599636E+03	3.5417959E+06	604.41
.32004	5.8608011E+03	3.5422668E+06	604.40
.32254	5.8629988E+03	3.5435071E+06	604.38
.32505	5.8656482E+03	3.5450037E+06	604.37
.32784	5.8686407E+03	3.5466905E+06	604.35
.33009	5.8714918E+03	3.5482967E+06	604.33

B/B-UFSAR

TABLE 6.2-15 (Cont'd)

<u>TIME (S)</u>	<u>MASS FLOW (LB/S)</u>	<u>ENERGY FLOW (BTU/S)</u>	<u>AVG. ENTHALPY (BTU/LB)</u>
.33273	5.8741682E+03	3.5498034E+06	604.31
.33508	5.8771774E+03	3.5514986E+06	604.29
.33756	5.8802735E+03	3.5532429E+06	604.26
.34009	5.8841700E+03	3.5554426E+06	604.24
.34260	5.8884789E+03	3.5578797E+06	604.21
.34507	5.8930780E+03	3.5604779E+06	604.18
.34755	5.8975952E+03	3.5630314E+06	604.15
.35027	5.9014291E+03	3.5651946E+06	604.12
.35257	5.9039809E+03	3.5666279E+06	604.11
.35506	5.9044769E+03	3.5668906E+06	604.10
.35763	5.9024245E+03	3.5657013E+06	604.11
.35011	5.8983568E+03	3.5633740E+06	604.13
.36265	5.8905550E+03	3.5589069E+06	604.17
.36502	5.8818991E+03	3.5539585E+06	604.22
.36763	5.8702901E+03	3.5473402E+06	604.29
.37011	5.8585785E+03	3.5406607E+06	604.35
.37259	5.8478945E+03	3.5345723E+06	604.42
.37512	5.8384907E+03	3.5292171E+06	604.47
.37757	5.8315699E+03	3.5252690E+06	604.51
.38001	5.8283142E+03	3.5234085E+06	604.53
.38255	5.8284433E+03	3.5234795E+06	604.53
.38504	5.8325211E+03	3.5257837E+06	604.50
.38764	5.8405465E+03	3.5303363E+06	604.45
.39003	5.8503172E+03	3.5358907E+06	604.39
.39255	5.8632583E+03	3.5432350E+06	604.31
.39507	5.8769944E+03	3.5510359E+06	604.23
.39752	5.8901754E+03	3.5585146E+06	604.14
.40002	5.9026209E+03	3.5655867E+06	604.07
.40266	5.9140894E+03	3.5720883E+06	604.00
.40506	5.9222442E+03	3.5767163E+06	603.95
.40761	5.9272907E+03	3.5795690E+06	603.91
.41010	5.9287654E+03	3.5803886E+06	603.90
.41261	5.9266016E+03	3.5791393E+06	603.91
.41515	5.9207163E+03	3.5757700E+06	603.94
.41756	5.9120146E+03	3.5708002E+06	603.99
.42010	5.9007105E+03	3.5643532E+06	604.05
.42264	5.8873278E+03	3.5567264E+06	604.13
.42510	5.8733889E+03	3.5487826E+06	604.21
.42776	5.8596323E+03	3.5409490E+06	604.30
.43002	5.8458384E+03	3.5330901E+06	604.38
.43273	5.8331063E+03	3.5258467E+06	604.45
.43505	5.8221311E+03	3.5196022E+06	604.52
.43751	5.8130794E+03	3.5144558E+06	604.58
.44011	5.8051154E+03	3.5099211E+06	604.63
.44254	5.7994338E+03	3.5066831E+06	604.65
.44510	5.7943623E+03	3.5037894E+06	604.69
.44756	5.7908671E+03	3.5017915E+06	604.71

B/B-UFSAR

TABLE 6.2-15 (Cont'd)

<u>TIME (S)</u>	<u>MASS FLOW (LB/S)</u>	<u>ENERGY FLOW (BTU/S)</u>	<u>AVG. ENTHALPY (BTU/LB)</u>
.45006	5.7884098E+03	3.5003828E+06	604.72
.45255	5.7868114E+03	3.4994613E+06	604.73
.45501	5.7860305E+03	3.4990035E+06	604.73
.45755	5.7859404E+03	3.4989362E+06	604.73
.46008	5.7865023E+03	3.4992415E+06	604.72
.46255	5.7876727E+03	3.4998863E+06	604.71
.46505	5.7891053E+03	3.5006850E+06	604.70
.46756	5.7908624E+03	3.5016617E+06	604.69
.47006	5.7926250E+03	3.5026427E+06	604.67
.47253	5.7940101E+03	3.5034098E+06	604.66
.47514	5.7949974E+03	3.5039478E+06	604.65
.47751	5.7952080E+03	3.5040456E+06	604.65
.48017	5.7945401E+03	3.5036413E+06	604.65
.48257	5.7927826E+03	3.5026177E+06	604.65
.48509	5.7901457E+03	3.5010969E+06	604.66
.48757	5.7864539E+03	3.4989748E+06	604.68
.49011	5.7818731E+03	3.4963467E+06	604.71
.49257	5.7768716E+03	3.4934807E+06	604.74
.49505	5.7713451E+06	3.4903136E+06	604.77
.49760	5.7657954E+06	3.4871343E+06	604.80
.50011	5.7603602E+03	3.4840234E+06	604.83
.51009	5.7491923E+03	3.4775926E+06	604.88
.52009	5.7609480E+03	3.4841862E+06	604.79
.53006	5.7844690E+03	3.4974703E+06	604.63
.54005	5.7987721E+03	3.5055003E+06	604.52
.55000	5.7970116E+03	3.5044053E+06	604.52
.56006	5.7863331E+03	3.4982404E+06	604.57
.57002	5.7741241E+03	3.4912139E+06	604.63
.58007	5.7631540E+03	3.4848951E+06	604.69
.59036	5.7548799E+03	3.4801119E+06	604.72
.60004	5.7492097E+03	3.4768050E+06	604.75
.61010	5.7426034E+03	3.4729615E+06	604.77
.62004	5.7325199E+03	3.4671373E+06	604.82
.63014	5.7211947E+03	3.4605989E+06	604.87
.64006	5.7162332E+03	3.4576773E+06	604.89
.65003	5.7176191E+03	3.4583568E+06	604.86
.66012	5.7204578E+03	3.4598599E+06	604.82
.67003	5.7223865E+03	3.4608454E+06	604.79
.68006	5.7257890E+03	3.4626698E+06	604.75
.69002	5.7317272E+03	3.4659330E+06	604.69
.70010	5.7366181E+03	3.4686004E+06	604.64
.71004	5.7366207E+03	3.4684965E+06	604.62
.72003	5.7320245E+03	3.4657852E+06	604.64
.73012	5.7251012E+03	3.4617536E+06	604.66
.74005	5.7172129E+03	3.4571775E+06	604.70
.75003	5.7094890E+03	3.4526916E+06	604.73
.76011	5.7035213E+03	3.4491984E+06	604.75

B/B-UFSAR

TABLE 6.2-15 (Cont'd)

<u>TIME (S)</u>	<u>MASS FLOW (LB/S)</u>	<u>ENERGY FLOW (BTU/S)</u>	<u>AVG. ENTHALPY (BTU/LB)</u>
.77015	5.6997968E+03	3.4469781E+06	604.75
.78006	5.6960407E+03	3.4447350E+06	604.76
.79006	5.6906934E+03	3.4415867E+06	604.77
.80005	5.6856760E+03	3.4386253E+06	604.79
.81021	5.6845992E+03	3.4379041E+06	604.78
.82006	5.6883128E+03	3.4399046E+06	604.73
.83010	5.6942403E+03	3.4431581E+06	604.67
.84013	5.6985107E+03	3.4454743E+06	604.63
.85000	5.6994327E+03	3.4458899E+06	604.60
.86014	5.6970829E+03	3.4444488E+06	604.60
.87001	5.6929918E+03	3.4420216E+06	604.61
.88010	5.6890670E+03	3.4396914E+06	604.61
.89006	5.6860123E+03	3.4378527E+06	604.62
.90008	5.6830007E+03	3.4360407E+06	604.62
.91009	5.6783432E+03	3.4332928E+06	604.63
.92011	5.6715216E+03	3.4293170E+06	604.66
.93018	5.6647085E+03	3.4253454E+06	604.68
.94003	5.6629152E+03	3.4242285E+06	604.68
.95003	5.6673076E+03	3.4266195E+06	604.63
.96010	5.6722227E+03	3.4293052E+06	604.58
.97011	5.6735480E+03	3.4299524E+06	604.55
.98001	5.6715705E+03	3.4287262E+06	604.55
.99004	5.6708125E+03	3.4281936E+06	604.53
1.00005	5.6717795E+03	3.4286424E+06	604.51
1.05002	5.6542380E+03	3.4181930E+06	604.54
1.10009	5.6578617E+03	3.4197733E+06	604.43
1.15011	5.6427925E+03	3.4107498E+06	604.44
1.20005	5.6426635E+03	3.4102125E+06	604.36
1.25004	5.6325971E+03	3.4040406E+06	604.35
1.30006	5.6245751E+03	3.3990528E+06	604.32
1.35009	5.6163063E+03	3.3939444E+06	604.30
1.40023	5.6056208E+03	3.3874824E+06	604.30
1.45004	5.5990362E+03	3.3833512E+06	604.27
1.50006	5.5888967E+03	3.3772132E+06	604.27
1.55004	5.5798754E+03	3.3717233E+06	604.26
1.60010	5.5703163E+03	3.3659471E+06	604.26
1.65004	5.5670531E+03	3.3637635E+06	604.23
1.70008	5.5583218E+03	3.3584925E+06	604.23
1.75012	5.5601180E+03	3.3591994E+06	604.16
1.80010	5.5588433E+03	3.3581573E+06	604.11
1.85006	5.5580249E+03	3.3573797E+06	604.06
1.90001	5.5513019E+03	3.3532637E+06	604.05
1.95012	5.5450010E+03	3.3494269E+06	604.04
2.00000	5.5358334E+03	3.3439853E+06	604.06

TABLE 6.2-16

SUBCOMPARTMENT STEAMLINER MASS AND ENERGY RELEASE RATES

TIME (sec)	MASS FLOW (lbm/sec)	ENERGY FLOW (Btu/sec)	AVE ENTHALPY (Btu/lbm)
0.0	20140.	24.03 (10 ⁶)	1193.15
0.187	20140.	24.03 (10 ⁶)	1193.15
0.1871	14560.	17.31 (10 ⁶)	1188.87
1.03	14560.	17.31 (10 ⁶)	1188.87
1.031	21980.	19.69 (10 ⁶)	895.81
1.480	21980.	19.69 (10 ⁶)	895.81
1.481	42560.	24.84 (10 ⁶)	583.65
4.0	42560.	24.84 (10 ⁶)	583.65

TABLE 6.2-17

LOCA MASS AND ENERGY CALCULATION SYSTEM PARAMETERS
AND INITIAL CONDITONS

	Unit 1	Unit 2
Core Thermal Power (MWt)	3658.3	3658.3
Reactor Coolant System Total Flowrate (lbm/sec)	37590.0	37590.0
Vessel Outlet Temperature (°F)	630.0	630.0
Core Inlet Temperature (°F)	564.2	564.2
Vessel Average Temperature (°F)	597.1	597.1
Initial Steam Generator Steam Pressure (psia)	1055.0	967.0
Steam Generator Design	BWI	D5
Steam Generator Tube Plugging (%)	0	0
Initial Steam Generator Secondary Side Mass (lbm)	136617.8	106484.0
Assumed Maximum Containment Backpressure (psia)	57.5	53.1
Accumulator		
Water Volume (ft ³) per accumulator	1005.2	1015.4
N ₂ Cover Gas Pressure (psia)	661.7	661.7
Temperature (°F)	120.	120.
Safety Injection Delay, total (sec) (from beginning of event)	40.0	40.0

Note: Core Thermal Power, RCS Total Flowrate, RCS Coolant Temperatures, and SG Secondary Side Mass include appropriate uncertainty and/or allowance.

TABLE 6.2-18

SAFETY INJECTION FLOW MINIMUM SAFEGUARDS

<u>RCS Pressure (psia)</u>	<u>Total Flow (gpm)</u>
Injection Mode (Reflood Phase)	
15	4637
40.0	4334
60.0	4070
80.0	3776
100.0	3448
120.0	3065
156	2229
157	1847
182	951
300	914
Injection Mode (Post-Reflood Phase)	
57.5	3121
Cold Leg Recirculation Mode	
15	3208

TABLE 6.2-18a

SAFETY INJECTION FLOW MAXIMUM SAFEGUARDS

<u>RCS Pressure (psia)</u>	<u>Total Flow (gpm)</u>
Injection Mode (Reflood Phase)	
14.7	12305
60.0	12288
135.0	12226
327.0	1582
600.0	1460
1800.0	659.4
1840.0	542.2
2200.0	457.1
3000.0	59.50
3035.0	1.40
Injection Mode (Post-Reflood Phase)	
64.7	12305
Cold Leg Recirculation Mode	
64.7	11917.1

TABLE 6.2-19
DOUBLE-ENDED HOT LEG BREAK BLOWDOWN MASS AND ENERGY
RELEASES - UNIT 1

TIME (SECONDS)	<u>BREAK PATH NO. 1*</u>		<u>BREAK PATH NO. 2**</u>	
	FLOW (LBM/SEC)	ENERGY (THOUSANDS BTU/SEC)	FLOW (LBM/SEC)	ENERGY (THOUSANDS BTU/SEC)
0.000000E+00	0.000000E+00	0.000000E+00	0.000000E+00	0.000000E+00
1.136569E-03	1.981244E+03	1.305073E+03	1.981195E+03	1.304095E+03
2.225097E-03	4.469539E+03	2.949784E+03	4.802721E+03	3.154095E+03
1.010666E-01	4.364407E+04	2.906676E+04	2.816140E+04	1.845540E+04
2.017220E-01	3.713050E+04	2.486636E+04	2.514056E+04	1.636802E+04
3.014055E-01	3.786656E+04	2.536512E+04	2.269461E+04	1.458722E+04
4.020405E-01	3.680105E+04	2.466135E+04	2.144752E+04	1.357423E+04
5.021913E-01	3.655559E+04	2.451123E+04	2.074680E+04	1.293836E+04
6.015960E-01	3.617254E+04	2.428148E+04	2.023222E+04	1.245708E+04
7.012418E-01	3.564828E+04	2.396763E+04	1.980895E+04	1.206322E+04
8.021292E-01	3.498504E+04	2.357075E+04	1.950969E+04	1.177083E+04
9.018791E-01	3.432423E+04	2.318283E+04	1.925554E+04	1.152796E+04
1.001989E+00	3.376350E+04	2.286955E+04	1.903638E+04	1.132218E+04
1.101259E+00	3.328995E+04	2.261930E+04	1.886712E+04	1.115850E+04
1.201269E+00	3.281336E+04	2.236957E+04	1.874167E+04	1.102907E+04
1.301455E+00	3.230968E+04	2.210597E+04	1.860977E+04	1.090385E+04
1.402018E+00	3.173211E+04	2.177803E+04	1.853968E+04	1.082045E+04
1.501946E+00	3.121072E+04	2.147450E+04	1.848849E+04	1.075342E+04
1.602039E+00	3.077590E+04	2.121976E+04	1.847840E+04	1.071388E+04
1.701849E+00	3.041167E+04	2.101002E+04	1.848448E+04	1.068706E+04
1.801440E+00	3.002069E+04	2.077973E+04	1.850464E+04	1.067135E+04
1.901064E+00	2.952994E+04	2.047459E+04	1.852745E+04	1.065984E+04
2.001933E+00	2.897096E+04	2.011568E+04	1.855001E+04	1.065052E+04
2.101737E+00	2.845629E+04	1.978421E+04	1.857124E+04	1.064314E+04
2.202072E+00	2.803529E+04	1.952019E+04	1.859173E+04	1.063761E+04
2.301777E+00	2.768693E+04	1.930767E+04	1.860849E+04	1.063234E+04
2.401838E+00	2.727659E+04	1.904636E+04	1.861705E+04	1.062456E+04
2.501063E+00	2.681621E+04	1.874109E+04	1.861362E+04	1.061218E+04
2.601881E+00	2.637916E+04	1.844716E+04	1.860175E+04	1.059678E+04
2.702116E+00	2.600690E+04	1.819670E+04	1.858147E+04	1.057845E+04
2.801007E+00	2.567127E+04	1.796940E+04	1.855231E+04	1.055676E+04
2.902041E+00	2.534313E+04	1.774318E+04	1.851038E+04	1.052919E+04
3.001746E+00	2.503697E+04	1.752795E+04	1.845883E+04	1.049750E+04
3.101384E+00	2.472640E+04	1.730371E+04	1.839692E+04	1.046108E+04
3.201848E+00	2.442973E+04	1.708376E+04	1.832397E+04	1.041941E+04
3.301282E+00	2.418448E+04	1.689747E+04	1.824521E+04	1.037529E+04
3.401048E+00	2.396290E+04	1.672475E+04	1.816031E+04	1.032840E+04
3.501050E+00	2.374360E+04	1.654941E+04	1.806804E+04	1.027794E+04

TABLE 6.2-19 (Cont'd)
DOUBLE-ENDED HOT LEG BREAK BLOWDOWN MASS AND ENERGY
RELEASES - UNIT 1

TIME (SECONDS)	<u>BREAK PATH NO. 1*</u>		<u>BREAK PATH NO. 2**</u>	
	FLOW (LBM/SEC)	ENERGY (THOUSANDS BTU/SEC)	FLOW (LBM/SEC)	ENERGY (THOUSANDS BTU/SEC)
3.601535E+00	2.355206E+04	1.639011E+04	1.796922E+04	1.022426E+04
3.702248E+00	2.338443E+04	1.624483E+04	1.786700E+04	1.016902E+04
3.801851E+00	2.322238E+04	1.610064E+04	1.776147E+04	1.011215E+04
3.901865E+00	2.308355E+04	1.597001E+04	1.765117E+04	1.005280E+04
4.001381E+00	2.296986E+04	1.585535E+04	1.753888E+04	9.992433E+03
4.200277E+00	2.277596E+04	1.564406E+04	1.731015E+04	9.869732E+03
4.401064E+00	2.264260E+04	1.546889E+04	1.707249E+04	9.742434E+03
4.600691E+00	2.256532E+04	1.532953E+04	1.682265E+04	9.608598E+03
4.800551E+00	2.256713E+04	1.524394E+04	1.655553E+04	9.465695E+03
5.001260E+00	2.258123E+04	1.517013E+04	1.628597E+04	9.322498E+03
5.200625E+00	2.260562E+04	1.511105E+04	1.599639E+04	9.168524E+03
5.401057E+00	2.268539E+04	1.509257E+04	1.569545E+04	9.009836E+03
5.601221E+00	2.277335E+04	1.507864E+04	1.553430E+04	8.934081E+03
5.800035E+00	2.288581E+04	1.508012E+04	1.524976E+04	8.785014E+03
6.000891E+00	2.302976E+04	1.510512E+04	1.495383E+04	8.630464E+03
6.200581E+00	2.322893E+04	1.516187E+04	1.473212E+04	8.519643E+03
6.401200E+00	2.367199E+04	1.533825E+04	1.444347E+04	8.370808E+03
6.600779E+00	1.802055E+04	1.263854E+04	1.416804E+04	8.230153E+03
6.800787E+00	1.812224E+04	1.261167E+04	1.387136E+04	8.078322E+03
7.000594E+00	1.829682E+04	1.263295E+04	1.361608E+04	7.950740E+03
7.200255E+00	1.849791E+04	1.268465E+04	1.335995E+04	7.821767E+03
7.400783E+00	1.868623E+04	1.274535E+04	1.308070E+04	7.678107E+03
7.600621E+00	1.879766E+04	1.273876E+04	1.282418E+04	7.547690E+03
7.801070E+00	1.893151E+04	1.274407E+04	1.256872E+04	7.417325E+03
8.000961E+00	1.908041E+04	1.275297E+04	1.231318E+04	7.286167E+03
8.200760E+00	1.925119E+04	1.278136E+04	1.206748E+04	7.160166E+03
8.400505E+00	1.936248E+04	1.278889E+04	1.182302E+04	7.033966E+03
8.600423E+00	1.946427E+04	1.281815E+04	1.158666E+04	6.911783E+03
8.800213E+00	1.957214E+04	1.282412E+04	1.135532E+04	6.791635E+03
9.000226E+00	1.970159E+04	1.285731E+04	1.112770E+04	6.672921E+03
9.200102E+00	1.958149E+04	1.276860E+04	1.090565E+04	6.556969E+03
9.400482E+00	1.962870E+04	1.277748E+04	1.068559E+04	6.441778E+03
9.600073E+00	1.982161E+04	1.286686E+04	1.046985E+04	6.328808E+03
9.800600E+00	2.077398E+04	1.343048E+04	1.025803E+04	6.217982E+03
1.000115E+01	2.056547E+04	1.329705E+04	1.004317E+04	6.105080E+03
1.020077E+01	2.011602E+04	1.300905E+04	9.828795E+03	5.992326E+03
1.040066E+01	1.945044E+04	1.258888E+04	9.612113E+03	5.878351E+03

TABLE 6.2-19 (Cont'd)
DOUBLE-ENDED HOT LEG BREAK BLOWDOWN MASS AND ENERGY
RELEASES - UNIT 1

TIME (SECONDS)	<u>BREAK PATH NO. 1*</u>		<u>BREAK PATH NO. 2**</u>	
	FLOW (LBM/SEC)	ENERGY (THOUSANDS BTU/SEC)	FLOW (LBM/SEC)	ENERGY (THOUSANDS BTU/SEC)
1.060126E+01	1.772603E+04	1.161076E+04	9.394712E+03	5.764684E+03
1.080010E+01	1.587047E+04	1.061079E+04	9.186068E+03	5.656332E+03
1.100110E+01	1.556561E+04	1.044238E+04	8.979850E+03	5.549806E+03
1.120025E+01	1.545671E+04	1.038639E+04	8.794084E+03	5.455465E+03
1.140013E+01	1.532507E+04	1.032687E+04	8.605661E+03	5.357952E+03
1.160199E+01	1.511327E+04	1.023078E+04	8.424727E+03	5.264464E+03
1.180124E+01	1.486643E+04	1.011892E+04	8.248275E+03	5.172424E+03
1.200229E+01	1.455425E+04	9.972534E+03	8.072688E+03	5.081064E+03
1.220131E+01	1.417368E+04	9.786588E+03	7.895813E+03	4.988209E+03
1.240011E+01	1.372743E+04	9.561555E+03	7.718821E+03	4.895384E+03
1.260156E+01	1.320924E+04	9.294034E+03	7.530892E+03	4.796510E+03
1.280173E+01	1.269197E+04	9.026611E+03	7.342292E+03	4.698154E+03
1.300040E+01	1.221369E+04	8.783600E+03	7.150098E+03	4.599097E+03
1.320225E+01	1.177385E+04	8.565955E+03	6.953402E+03	4.498793E+03
1.340048E+01	1.137079E+04	8.373949E+03	6.762669E+03	4.402552E+03
1.360088E+01	1.097201E+04	8.188629E+03	6.569750E+03	4.305375E+03
1.380249E+01	1.057520E+04	8.008374E+03	6.380345E+03	4.210286E+03
1.400027E+01	1.017803E+04	7.828701E+03	6.197790E+03	4.118726E+03
1.420195E+01	9.780504E+03	7.627593E+03	6.013487E+03	4.026446E+03
1.440130E+01	9.408362E+03	7.417638E+03	5.832524E+03	3.936004E+03
1.460142E+01	8.673632E+03	7.149910E+03	5.649397E+03	3.844226E+03
1.480008E+01	8.001020E+03	6.894744E+03	5.456206E+03	3.747180E+03
1.500168E+01	7.514628E+03	6.644738E+03	5.234247E+03	3.635533E+03
1.520058E+01	7.079692E+03	6.343542E+03	4.983831E+03	3.512673E+03
1.540094E+01	6.680932E+03	6.001052E+03	4.693976E+03	3.373621E+03
1.560161E+01	6.276776E+03	5.664700E+03	4.370144E+03	3.221605E+03
1.580286E+01	5.840198E+03	5.358915E+03	4.024634E+03	3.063606E+03
1.600115E+01	5.398774E+03	5.070309E+03	3.679990E+03	2.910138E+03
1.620167E+01	4.979895E+03	4.809716E+03	3.341510E+03	2.761621E+03
1.640066E+01	4.603250E+03	4.563853E+03	3.030430E+03	2.626155E+03
1.660012E+01	4.286443E+03	4.353305E+03	2.749695E+03	2.503912E+03
1.680001E+01	3.995029E+03	4.151719E+03	2.498696E+03	2.398342E+03
1.700097E+01	3.743585E+03	3.960781E+03	2.279294E+03	2.303316E+03
1.720111E+01	3.531337E+03	3.772739E+03	2.094329E+03	2.221109E+03
1.740031E+01	3.303220E+03	3.596706E+03	1.937519E+03	2.146365E+03
1.760088E+01	3.094949E+03	3.425978E+03	1.805141E+03	2.074332E+03
1.780061E+01	2.889015E+03	3.252369E+03	1.705136E+03	2.001698E+03
1.800081E+01	2.678452E+03	3.082673E+03	1.621000E+03	1.933542E+03
1.820051E+01	2.459352E+03	2.915072E+03	1.535581E+03	1.855843E+03

TABLE 6.2-19 (Cont'd)
DOUBLE-ENDED HOT LEG BREAK BLOWDOWN MASS AND ENERGY
RELEASES - UNIT 1

TIME (SECONDS)	<u>BREAK PATH NO. 1*</u>		<u>BREAK PATH NO. 2**</u>	
	FLOW (LBM/SEC)	ENERGY (THOUSANDS BTU/SEC)	FLOW (LBM/SEC)	ENERGY (THOUSANDS BTU/SEC)
1.840050E+01	2.257880E+03	2.756039E+03	1.466876E+03	1.785041E+03
1.860037E+01	2.075561E+03	2.566914E+03	1.396607E+03	1.710795E+03
1.880036E+01	1.932771E+03	2.402269E+03	1.334911E+03	1.641722E+03
1.900072E+01	1.847116E+03	2.298474E+03	1.268106E+03	1.565991E+03
1.920021E+01	1.779350E+03	2.207371E+03	1.211160E+03	1.499180E+03
1.940008E+01	1.702899E+03	2.110505E+03	1.150422E+03	1.427177E+03
1.960060E+01	1.628025E+03	2.017264E+03	1.081777E+03	1.344845E+03
1.980084E+01	1.540895E+03	1.912596E+03	1.071304E+03	1.332630E+03
2.000037E+01	1.490006E+03	1.844864E+03	9.510567E+02	1.187245E+03
2.020025E+01	1.437047E+03	1.778764E+03	9.090874E+02	1.138235E+03
2.040047E+01	1.381979E+03	1.714633E+03	8.847229E+02	1.107523E+03
2.060074E+01	1.333615E+03	1.655293E+03	7.554726E+02	9.452926E+02
2.080056E+01	1.308645E+03	1.619556E+03	6.734434E+02	8.468439E+02
2.100009E+01	1.264137E+03	1.565262E+03	6.886886E+02	8.661698E+02
2.120029E+01	1.169982E+03	1.463886E+03	5.142743E+02	6.455853E+02
2.140031E+01	9.916302E+02	1.255658E+03	4.836827E+02	6.102703E+02
2.160069E+01	8.683320E+02	1.100489E+03	4.104543E+02	5.183179E+02
2.180009E+01	7.477787E+02	9.465984E+02	3.791735E+02	4.793563E+02
2.200005E+01	6.732130E+02	8.510310E+02	3.407533E+02	4.312895E+02
2.220022E+01	5.078378E+02	6.390096E+02	2.963604E+02	3.756072E+02
2.240007E+01	3.637155E+02	4.582568E+02	2.530364E+02	3.212080E+02
2.260025E+01	2.199548E+02	2.772678E+02	2.230309E+02	2.836470E+02
2.280006E+01	6.520866E+01	8.212824E+01	2.012356E+02	2.562874E+02
2.300007E+01	0.000000E+00	0.000000E+00	1.870256E+02	2.384584E+02
2.320039E+01	0.000000E+00	0.000000E+00	1.781108E+02	2.273034E+02
2.340047E+01	0.000000E+00	0.000000E+00	1.653825E+02	2.112354E+02
2.360086E+01	0.000000E+00	0.000000E+00	1.515186E+02	1.937304E+02
2.380001E+01	0.000000E+00	0.000000E+00	1.220676E+02	1.563600E+02
2.400038E+01	0.000000E+00	0.000000E+00	7.893525E+01	1.015105E+02
2.420041E+01	0.000000E+00	0.000000E+00	0.000000E+00	0.000000E+00

* mass and energy exiting from the reactor vessel side of the break

** mass and energy exiting from the SG side of the break

TABLE 6.2-20

DOUBLE-ENDED HOT LEG BREAK MASS BALANCE - UNIT 1

Time (seconds)		0.00	24.20	24.20
		<u>Mass (thousand lbm)</u>		
Initial	In RCS and ACC	816.31	816.31	816.31
Added Mass	Pumped Injection	0.00	0.00	0.00
	Total Added	0.00	0.00	0.00
TOTAL AVAILABLE		816.31	816.31	816.31
Distribution	Reactor Coolant	567.44	81.91	119.32
	Accumulator	248.87	192.70	155.28
	Total Contents	816.31	274.61	274.61
Effluent	Break Flow	0.00	541.70	541.70
	ECCS Spill	0.00	0.00	0.00
	Total Effluent	0.00	541.70	541.70
TOTAL ACCOUNTABLE		816.31	816.31	816.31

TABLE 6.2-21

DOUBLE-ENDED HOT LEG BREAK ENERGY BALANCE - UNIT 1

Time (Seconds)		0.00	24.20	24.20
		<u>Energy (Millions BTU)</u>		
Initial Energy	In RCS, ACC, S Gen	968.81	968.81	968.81
Added Energy	Pumped Injection	0.00	0.00	0.00
	Decay Heat	0.00	8.44	8.44
	Heat From Secondary	0.00	-1.43	-1.43
	Total Added	0.00	7.01	7.01
TOTAL AVAILABLE		968.81	975.82	975.82
Distribution	Reactor Coolant	341.62	21.45	25.17
	Accumulator	22.27	17.25	13.52
	Core Stored	23.64	9.15	9.15
	Primary Metal	177.44	166.45	166.45
	Secondary Metal	91.73	90.30	90.30
	Steam Generator	312.11	306.16	306.16
	Total Contents	968.81	610.75	610.75
Effluent	Break Flow	0.00	364.49	364.49
	ECCS Spill	0.00	0.00	0.00
	Total Effluent	0.00	364.49	364.49
TOTAL ACCOUNTABLE		968.81	975.25	975.25

TABLE 6.2-22

DOUBLE-ENDED PUMP SUCTION BREAK MINIMUM SAFEGUARDS BLOWDOWN
MASS AND ENERGY RELEASES - UNIT 1

<u>BREAK PATH NO. 1*</u>			<u>BREAK PATH NO. 2**</u>	
TIME (SECONDS)	FLOW (LBM/SEC)	ENERGY (THOUSANDS BTU/SEC)	FLOW (LBM/SEC)	ENERGY (THOUSANDS BTU/SEC)
0.000000E+00	0.000000E+00	0.000000E+00	0.000000E+00	0.000000E+00
1.034320E-03	3.974167E+03	2.244921E+03	3.873405E+03	2.186273E+03
2.110625E-03	8.357797E+03	4.722952E+03	6.127431E+03	3.433822E+03
1.010317E-01	3.864359E+04	2.169448E+04	1.953608E+04	1.095706E+04
2.013933E-01	4.259477E+04	2.401627E+04	2.475321E+04	1.386668E+04
3.026177E-01	4.328062E+04	2.454098E+04	2.518198E+04	1.412055E+04
4.013396E-01	4.288059E+04	2.447788E+04	2.460445E+04	1.381289E+04
5.015953E-01	4.280252E+04	2.462482E+04	2.363604E+04	1.328087E+04
6.010946E-01	4.294813E+04	2.492212E+04	2.279934E+04	1.281741E+04
7.020801E-01	4.194388E+04	2.456380E+04	2.205368E+04	1.240151E+04
8.017773E-01	4.229633E+04	2.499043E+04	2.143479E+04	1.205579E+04
9.012152E-01	4.258348E+04	2.537111E+04	2.095673E+04	1.178915E+04
1.001484E+00	4.265618E+04	2.561673E+04	2.063771E+04	1.161082E+04
1.101249E+00	4.245677E+04	2.568351E+04	2.043265E+04	1.149735E+04
1.202050E+00	4.202206E+04	2.559664E+04	2.033318E+04	1.144217E+04
1.301385E+00	4.149956E+04	2.544418E+04	2.025972E+04	1.140144E+04
1.401753E+00	4.094964E+04	2.527057E+04	2.019994E+04	1.136759E+04
1.501988E+00	4.039875E+04	2.509314E+04	2.017202E+04	1.135145E+04
1.601793E+00	3.984687E+04	2.491428E+04	2.018923E+04	1.136090E+04
1.702089E+00	3.929318E+04	2.473864E+04	2.022469E+04	1.138077E+04
1.801475E+00	3.874870E+04	2.457495E+04	2.023936E+04	1.138874E+04
1.901665E+00	3.814051E+04	2.438272E+04	2.020228E+04	1.136716E+04
2.001414E+00	3.704777E+04	2.388868E+04	2.012624E+04	1.132367E+04
2.101062E+00	3.593826E+04	2.338633E+04	2.004712E+04	1.127881E+04
2.201143E+00	3.477670E+04	2.285010E+04	1.995066E+04	1.122454E+04
2.301349E+00	3.370659E+04	2.236756E+04	1.962235E+04	1.103877E+04
2.401063E+00	3.267109E+04	2.189375E+04	1.933433E+04	1.087719E+04
2.501095E+00	3.163547E+04	2.140290E+04	1.913577E+04	1.076615E+04
2.601522E+00	3.061727E+04	2.090373E+04	1.893311E+04	1.065275E+04
2.701316E+00	2.965560E+04	2.042284E+04	1.873613E+04	1.054277E+04
2.801222E+00	2.874144E+04	1.995603E+04	1.852095E+04	1.042277E+04
2.901322E+00	2.785723E+04	1.949122E+04	1.828391E+04	1.029064E+04
3.001562E+00	2.696690E+04	1.900356E+04	1.804577E+04	1.015810E+04
3.101285E+00	2.603043E+04	1.846676E+04	1.783050E+04	1.003875E+04
3.201407E+00	2.513685E+04	1.794931E+04	1.763307E+04	9.929664E+03

TABLE 6.2-22 (Cont'd)

DOUBLE-ENDED PUMP SUCTION BREAK MINIMUM SAFEGUARDS BLOWDOWN				
MASS AND ENERGY RELEASES - UNIT 1				
TIME (SECONDS)	BREAK PATH NO. 1*		BREAK PATH NO. 2**	
	FLOW (LBM/SEC)	ENERGY (THOUSANDS BTU/SEC)	FLOW (LBM/SEC)	ENERGY (THOUSANDS BTU/SEC)
3.301214E+00	2.429263E+04	1.745179E+04	1.742301E+04	9.813486E+03
3.401483E+00	2.338694E+04	1.689364E+04	1.722265E+04	9.702922E+03
3.501047E+00	2.260003E+04	1.641218E+04	1.703062E+04	9.597299E+03
3.601067E+00	2.186566E+04	1.595664E+04	1.682601E+04	9.484474E+03
3.701619E+00	2.090998E+04	1.532048E+04	1.657414E+04	9.344862E+03
3.801254E+00	1.998167E+04	1.469415E+04	1.640038E+04	9.250050E+03
3.901557E+00	1.929204E+04	1.423793E+04	1.623882E+04	9.162025E+03
4.001659E+00	1.878249E+04	1.389319E+04	1.606899E+04	9.069196E+03
4.200645E+00	1.801069E+04	1.335108E+04	1.576700E+04	8.905213E+03
4.400101E+00	1.746988E+04	1.294222E+04	1.549478E+04	8.758094E+03
4.600685E+00	1.713915E+04	1.267093E+04	1.524914E+04	8.626354E+03
4.800583E+00	1.687424E+04	1.243341E+04	1.501967E+04	8.503776E+03
5.000416E+00	1.669402E+04	1.224872E+04	1.482058E+04	8.398519E+03
5.200773E+00	1.657638E+04	1.210240E+04	1.463900E+04	8.303189E+03
5.400696E+00	1.652749E+04	1.200056E+04	1.522851E+04	8.654721E+03
5.600454E+00	1.652980E+04	1.193021E+04	1.571859E+04	8.934006E+03
5.800379E+00	1.656265E+04	1.187955E+04	1.569834E+04	8.932161E+03
6.000278E+00	1.663127E+04	1.185366E+04	1.559092E+04	8.879317E+03
6.200446E+00	1.671501E+04	1.184095E+04	1.547559E+04	8.821523E+03
6.400014E+00	1.680410E+04	1.183699E+04	1.531484E+04	8.737298E+03
6.600527E+00	1.688689E+04	1.183608E+04	1.513089E+04	8.639168E+03
6.800535E+00	1.695088E+04	1.183241E+04	1.494991E+04	8.542077E+03
7.000036E+00	1.697129E+04	1.180993E+04	1.476022E+04	8.438813E+03
7.200672E+00	1.696200E+04	1.177574E+04	1.462494E+04	8.365728E+03
7.400690E+00	1.692737E+04	1.172319E+04	1.454800E+04	8.324426E+03
7.600061E+00	1.845504E+04	1.271539E+04	1.441993E+04	8.250279E+03
7.800739E+00	1.652321E+04	1.182507E+04	1.426486E+04	8.158825E+03
8.000743E+00	1.529427E+04	1.131571E+04	1.400858E+04	8.010213E+03
8.200665E+00	1.529547E+04	1.126313E+04	1.391721E+04	7.960426E+03
8.400691E+00	1.548889E+04	1.128664E+04	1.374051E+04	7.861354E+03
8.600151E+00	1.569309E+04	1.131852E+04	1.356666E+04	7.761234E+03
8.800354E+00	1.590652E+04	1.135823E+04	1.339035E+04	7.659523E+03
9.000071E+00	1.609711E+04	1.139263E+04	1.322589E+04	7.566096E+03
9.200517E+00	1.626049E+04	1.141877E+04	1.308048E+04	7.483136E+03
9.400302E+00	1.639402E+04	1.143600E+04	1.289193E+04	7.374451E+03
9.600366E+00	1.649390E+04	1.144280E+04	1.272752E+04	7.280387E+03
9.800135E+00	1.655118E+04	1.143177E+04	1.256927E+04	7.189850E+03
1.000072E+01	1.655784E+04	1.139711E+04	1.237873E+04	7.080205E+03
1.020027E+01	1.648771E+04	1.132628E+04	1.222667E+04	6.992960E+03
1.040075E+01	1.628190E+04	1.118909E+04	1.205019E+04	6.891176E+03
1.060038E+01	1.598904E+04	1.101215E+04	1.189706E+04	6.802760E+03
1.080049E+01	1.570310E+04	1.085268E+04	1.173673E+04	6.709812E+03
1.100017E+01	1.541835E+04	1.069136E+04	1.157299E+04	6.614415E+03
1.120090E+01	1.487864E+04	1.037997E+04	1.142897E+04	6.530449E+03

TABLE 6.2-22 (Cont'd)

DOUBLE-ENDED PUMP SUCTION BREAK MINIMUM SAFEGUARDS BLOWDOWN
MASS AND ENERGY RELEASES - UNIT 1

TIME (SECONDS)	<u>BREAK PATH NO. 1*</u>		<u>BREAK PATH NO. 2**</u>	
	FLOW (LBM/SEC)	ENERGY (THOUSANDS BTU/SEC)	FLOW (LBM/SEC)	ENERGY (THOUSANDS BTU/SEC)
1.140074E+01	1.417795E+04	9.967302E+03	1.128046E+04	6.443310E+03
1.160088E+01	1.341191E+04	9.501623E+03	1.114934E+04	6.365357E+03
1.180119E+01	1.267707E+04	9.056522E+03	1.101848E+04	6.286794E+03
1.200053E+01	1.198618E+04	8.636723E+03	1.089530E+04	6.211907E+03
1.220111E+01	1.115120E+04	8.121812E+03	1.079863E+04	6.151807E+03
1.240012E+01	1.028995E+04	7.616195E+03	1.073840E+04	6.110840E+03
1.260040E+01	9.680642E+03	7.297789E+03	1.062350E+04	6.035519E+03
1.280081E+01	9.187738E+03	7.055400E+03	1.056047E+04	5.991208E+03
1.300106E+01	8.726770E+03	6.835249E+03	1.046410E+04	5.927223E+03
1.320042E+01	8.342593E+03	6.653833E+03	1.037435E+04	5.866645E+03
1.340100E+01	8.014972E+03	6.490729E+03	1.028849E+04	5.808867E+03
1.360055E+01	7.707149E+03	6.334535E+03	1.020165E+04	5.750140E+03
1.380018E+01	7.428822E+03	6.201050E+03	1.010748E+04	5.687100E+03
1.400004E+01	7.153551E+03	6.068634E+03	1.002598E+04	5.631993E+03
1.420084E+01	6.859740E+03	5.923305E+03	9.892374E+03	5.547161E+03
1.440027E+01	6.525035E+03	5.753588E+03	9.718272E+03	5.442902E+03
1.460086E+01	6.193322E+03	5.589479E+03	9.639881E+03	5.395085E+03
1.480083E+01	5.871593E+03	5.431631E+03	9.420238E+03	5.263403E+03
1.500044E+01	5.564993E+03	5.279159E+03	9.336095E+03	5.210306E+03
1.520031E+01	5.296159E+03	5.142295E+03	9.187304E+03	5.104653E+03
1.540108E+01	5.073196E+03	5.035355E+03	9.027698E+03	4.988808E+03
1.560048E+01	4.809501E+03	4.971974E+03	8.978865E+03	4.911408E+03
1.580060E+01	4.377610E+03	4.874280E+03	8.707188E+03	4.679297E+03
1.600040E+01	3.964893E+03	4.734853E+03	8.607071E+03	4.527487E+03
1.620101E+01	3.547918E+03	4.367843E+03	7.683082E+03	3.945081E+03
1.640071E+01	3.180168E+03	3.947061E+03	7.946140E+03	3.964149E+03
1.660131E+01	2.939564E+03	3.662623E+03	7.122121E+03	3.496248E+03
1.680045E+01	2.761559E+03	3.450528E+03	6.390287E+03	3.041750E+03
1.700184E+01	2.580774E+03	3.232314E+03	6.486188E+03	2.994926E+03
1.720089E+01	2.425449E+03	3.045047E+03	5.696108E+03	2.590657E+03
1.740078E+01	2.282862E+03	2.871344E+03	5.518943E+03	2.444032E+03
1.760052E+01	2.145795E+03	2.703918E+03	5.423598E+03	2.346685E+03
1.780111E+01	2.007337E+03	2.533871E+03	5.445796E+03	2.315650E+03
1.800049E+01	1.882893E+03	2.380862E+03	4.357763E+03	1.826337E+03
1.820024E+01	1.766945E+03	2.237474E+03	5.023408E+03	2.065944E+03
1.840066E+01	1.650102E+03	2.092431E+03	5.865724E+03	2.360155E+03
1.860005E+01	1.537008E+03	1.951773E+03	5.827619E+03	2.315844E+03
1.880028E+01	1.434997E+03	1.824747E+03	5.020904E+03	1.984106E+03
1.900023E+01	1.346426E+03	1.714105E+03	4.240250E+03	1.666435E+03
1.920008E+01	1.266591E+03	1.614200E+03	3.730883E+03	1.464361E+03
1.940057E+01	1.192436E+03	1.521168E+03	3.101111E+03	1.212654E+03
1.960011E+01	1.114772E+03	1.423192E+03	2.209232E+03	8.364433E+02
1.980030E+01	1.029472E+03	1.315460E+03	3.994393E+03	1.329354E+03
2.000037E+01	1.004854E+03	1.285779E+03	4.695268E+03	1.514319E+03
2.020053E+01	9.022815E+02	1.156430E+03	4.629151E+03	1.484664E+03

TABLE 6.2-22 (Cont'd)

DOUBLE-ENDED PUMP SUCTION BREAK MINIMUM SAFEGUARDS BLOWDOWN
MASS AND ENERGY RELEASES - UNIT 1

TIME (SECONDS)	<u>BREAK PATH NO. 1*</u>		<u>BREAK PATH NO. 2**</u>	
	FLOW (LBM/SEC)	ENERGY (THOUSANDS BTU/SEC)	FLOW (LBM/SEC)	ENERGY (THOUSANDS BTU/SEC)
2.040040E+01	8.260868E+02	1.059304E+03	4.527376E+03	1.448778E+03
2.060047E+01	7.548188E+02	9.684592E+02	4.002044E+03	1.278970E+03
2.080018E+01	6.931217E+02	8.897620E+02	4.259611E+03	1.353917E+03
2.100062E+01	6.460405E+02	8.296601E+02	4.079198E+03	1.285733E+03
2.120015E+01	6.077127E+02	7.808458E+02	3.777844E+03	1.177334E+03
2.140012E+01	5.756026E+02	7.398513E+02	3.467181E+03	1.064525E+03
2.160058E+01	5.391455E+02	6.931864E+02	3.155815E+03	9.507623E+02
2.180007E+01	5.046990E+02	6.491196E+02	2.832556E+03	8.347701E+02
2.200004E+01	4.697669E+02	6.043963E+02	2.465527E+03	7.098810E+02
2.220036E+01	4.363833E+02	5.616268E+02	2.022515E+03	5.695186E+02
2.240029E+01	4.033184E+02	5.192293E+02	1.474985E+03	4.077649E+02
2.260046E+01	3.691338E+02	4.753645E+02	8.080785E+02	2.208681E+02
2.280021E+01	3.344058E+02	4.307745E+02	7.034820E+01	1.925262E+01
2.300030E+01	2.989089E+02	3.851790E+02	-3.359509E+01	-1.037001E+01
2.320017E+01	2.587792E+02	3.335580E+02	4.316361E-01	2.485597E-01
2.340058E+01	2.207146E+02	2.846336E+02	4.866756E+00	4.601038E+00
2.360066E+01	1.851994E+02	2.389603E+02	6.275055E+00	6.440765E+00
2.380059E+01	1.516632E+02	1.957848E+02	4.571865E+00	5.026985E+00
2.400025E+01	1.075738E+02	1.389917E+02	6.879789E+00	7.985954E+00
2.420040E+01	0.000000E+00	0.000000E+00	0.000000E+00	0.000000E+00

* mass and energy exiting the SG side of the break

** mass and energy exiting the pump side of the break

TABLE 6.2-23

DOUBLE-ENDED PUMP SUCTION BREAK MINIMUM SAFEGUARDS REFLOOD
MASS AND ENERGY RELEASES - UNIT 1

TIME (SECONDS)	<u>BREAK PATH NO. 1*</u>		<u>BREAK PATH NO. 2**</u>	
	FLOW (LBM/SEC)	ENERGY (THOUSANDS BTU/SEC)	FLOW (LBM/SEC)	ENERGY (THOUSANDS BTU/SEC)
2.477540E+01	4.590084E-04	5.401039E-04	1.377000E-04	1.327064E-05
2.487540E+01	4.590088E-04	5.401044E-04	1.377000E-04	1.327030E-05
2.507540E+01	4.590097E-04	5.401055E-04	1.377000E-04	1.326963E-05
2.517540E+01	4.590205E-04	5.401182E-04	1.377000E-04	1.322666E-05
2.527540E+01	4.590212E-04	5.401190E-04	1.377000E-04	1.322634E-05
2.537540E+01	5.834491E+01	6.865998E+01	1.377000E-04	1.537141E-05
2.548790E+01	2.263939E+01	2.664129E+01	1.377000E-04	1.394289E-05
2.561290E+01	1.253303E+01	1.474766E+01	1.377000E-04	1.359489E-05
2.571290E+01	1.539831E+01	1.811916E+01	1.377000E-04	1.373271E-05
2.581290E+01	2.160385E+01	2.542156E+01	1.377000E-04	1.404710E-05
2.591290E+01	2.968970E+01	3.493733E+01	1.377000E-04	1.426379E-05
2.601290E+01	3.573818E+01	4.205640E+01	1.377000E-04	1.444878E-05
2.611290E+01	3.976550E+01	4.679682E+01	1.377000E-04	1.458515E-05
2.621290E+01	4.380663E+01	5.155374E+01	1.377000E-04	1.472251E-05
2.631290E+01	4.760527E+01	5.602551E+01	1.377000E-04	1.485338E-05
2.641290E+01	5.120412E+01	6.026237E+01	1.377000E-04	1.497882E-05
2.651290E+01	5.462790E+01	6.429340E+01	1.377000E-04	1.510043E-05
2.661290E+01	5.791085E+01	6.815889E+01	1.377000E-04	1.521813E-05
2.671290E+01	6.106531E+01	7.187333E+01	1.377000E-04	1.533219E-05
2.678790E+01	6.335540E+01	7.457012E+01	1.377000E-04	1.541558E-05
2.681290E+01	6.410535E+01	7.545329E+01	1.377000E-04	1.544300E-05
2.691290E+01	6.704250E+01	7.891232E+01	1.377000E-04	1.555088E-05
2.701290E+01	6.988636E+01	8.226171E+01	1.377000E-04	1.565611E-05
2.711290E+01	7.264505E+01	8.551102E+01	1.377000E-04	1.575893E-05
2.721290E+01	7.532554E+01	8.866843E+01	1.377000E-04	1.585953E-05
2.821290E+01	9.885996E+01	1.164001E+02	1.377000E-04	1.677424E-05
2.921290E+01	1.183538E+02	1.393856E+02	1.377000E-04	1.757948E-05
3.021290E+01	1.352561E+02	1.593278E+02	1.377000E-04	1.831791E-05
3.121290E+01	1.976645E+02	2.330532E+02	1.577630E+03	2.199529E+02
3.180040E+01	3.586925E+02	4.241604E+02	3.769342E+03	5.497697E+02
3.230040E+01	3.868592E+02	4.578802E+02	4.032325E+03	6.125858E+02
3.330040E+01	3.863633E+02	4.573132E+02	4.023557E+03	6.180427E+02
3.430040E+01	3.803032E+02	4.500831E+02	3.962039E+03	6.117791E+02
3.530040E+01	3.739092E+02	4.424559E+02	3.896211E+03	6.045719E+02
3.630040E+01	3.675143E+02	4.348297E+02	3.829592E+03	5.970714E+02
3.700040E+01	3.631010E+02	4.295678E+02	3.783211E+03	5.917733E+02
3.730040E+01	3.612322E+02	4.273399E+02	3.763475E+03	5.895048E+02
3.830040E+01	3.551171E+02	4.200512E+02	3.698515E+03	5.819911E+02

DOUBLE-ENDED PUMP SUCTION BREAK MINIMUM SAFEGUARDS REFLOODMASS AND ENERGY RELEASES - UNIT 1

TIME (SECONDS)	<u>BREAK PATH NO. 1*</u>		<u>BREAK PATH NO. 2**</u>	
	FLOW (LBM/SEC)	ENERGY (THOUSANDS BTU/SEC)	FLOW (LBM/SEC)	ENERGY (THOUSANDS BTU/SEC)
3.930040E+01	3.491941E+02	4.129933E+02	3.635043E+03	5.745956E+02
4.030040E+01	3.434725E+02	4.061772E+02	3.573224E+03	5.673538E+02
4.130040E+01	3.379506E+02	3.996007E+02	3.513127E+03	5.602815E+02
4.230040E+01	3.326274E+02	3.932623E+02	3.454756E+03	5.533896E+02
4.330040E+01	3.274965E+02	3.871544E+02	3.398087E+03	5.466805E+02
4.385040E+01	3.575570E+02	4.228965E+02	3.761161E+03	5.770536E+02
4.435040E+01	3.544949E+02	4.193087E+02	3.725606E+03	5.730852E+02
4.535040E+01	3.497407E+02	4.136435E+02	3.674728E+03	5.669519E+02
4.635040E+01	3.451427E+02	4.081657E+02	3.625222E+03	5.609754E+02
4.735040E+01	3.406960E+02	4.028692E+02	3.577071E+03	5.551537E+02
4.835040E+01	3.363940E+02	3.977461E+02	3.530226E+03	5.494826E+02
4.935040E+01	3.322297E+02	3.927879E+02	3.484638E+03	5.439569E+02
5.035040E+01	3.281965E+02	3.879866E+02	3.440255E+03	5.385712E+02
5.135040E+01	3.242877E+02	3.833343E+02	3.397025E+03	5.333197E+02
5.235040E+01	3.204972E+02	3.788236E+02	3.354899E+03	5.281968E+02
5.335040E+01	3.168191E+02	3.744474E+02	3.313830E+03	5.231971E+02
5.435040E+01	3.132479E+02	3.701991E+02	3.273771E+03	5.183153E+02
5.535040E+01	3.097782E+02	3.660722E+02	3.234679E+03	5.135462E+02
5.635040E+01	3.064052E+02	3.620609E+02	3.196514E+03	5.088850E+02
5.735040E+01	3.031241E+02	3.581596E+02	3.159234E+03	5.043271E+02
5.835040E+01	2.999307E+02	3.543631E+02	3.122804E+03	4.998680E+02
5.935040E+01	2.968208E+02	3.506663E+02	3.087187E+03	4.955035E+02
5.975040E+01	2.955993E+02	3.492145E+02	3.073161E+03	4.937833E+02
6.035040E+01	2.937900E+02	3.470641E+02	3.052351E+03	4.912294E+02
6.135040E+01	2.908328E+02	3.435499E+02	3.018266E+03	4.870400E+02
6.235040E+01	2.879478E+02	3.401220E+02	2.984900E+03	4.829335E+02
6.335040E+01	2.851318E+02	3.367764E+02	2.952225E+03	4.789066E+02
6.435040E+01	2.823817E+02	3.335096E+02	2.920212E+03	4.749560E+02
6.535040E+01	2.378645E+02	2.806857E+02	2.338118E+03	4.096780E+02
6.635040E+01	4.090093E+02	4.842494E+02	3.129660E+02	2.268175E+02
6.735040E+01	4.235803E+02	5.017634E+02	3.191690E+02	2.359043E+02
6.835040E+01	4.134621E+02	4.896757E+02	3.145733E+02	2.297301E+02
6.935040E+01	4.028887E+02	4.770459E+02	3.097972E+02	2.233014E+02
7.035040E+01	3.923009E+02	4.644050E+02	3.050265E+02	2.168976E+02
7.135040E+01	3.826919E+02	4.529360E+02	3.007010E+02	2.111017E+02
7.235040E+01	3.736563E+02	4.421567E+02	2.966016E+02	2.056805E+02
7.335040E+01	3.650284E+02	4.318676E+02	2.926997E+02	2.005290E+02
7.435040E+01	3.567304E+02	4.219759E+02	2.889551E+02	1.955942E+02
7.535040E+01	3.487325E+02	4.124452E+02	2.853541E+02	1.908565E+02
7.615040E+01	3.425429E+02	4.050718E+02	2.825730E+02	1.872029E+02
7.635040E+01	3.410239E+02	4.032625E+02	2.818913E+02	1.863079E+02
7.735040E+01	3.335951E+02	3.944161E+02	2.785618E+02	1.819413E+02
7.835040E+01	3.264368E+02	3.858947E+02	2.753609E+02	1.777498E+02

TABLE 6.2-23 (Cont'd)

DOUBLE-ENDED PUMP SUCTION BREAK MINIMUM SAFEGUARDS REFLOOD
MASS AND ENERGY RELEASES - UNIT 1

TIME (SECONDS)	<u>BREAK PATH NO. 1*</u>		<u>BREAK PATH NO. 2**</u>	
	FLOW (LBM/SEC)	ENERGY (THOUSANDS BTU/SEC)	FLOW (LBM/SEC)	ENERGY (THOUSANDS BTU/SEC)
7.935040E+01	3.195406E+02	3.776878E+02	2.722843E+02	1.737270E+02
8.035040E+01	3.128970E+02	3.697840E+02	2.693275E+02	1.698664E+02
8.135040E+01	3.064894E+02	3.621633E+02	2.664830E+02	1.661575E+02
8.235040E+01	3.003182E+02	3.548258E+02	2.637500E+02	1.625988E+02
8.335040E+01	2.943771E+02	3.477639E+02	2.611251E+02	1.591853E+02
8.435040E+01	2.886581E+02	3.409678E+02	2.586043E+02	1.559114E+02
8.535040E+01	2.831544E+02	3.344292E+02	2.561843E+02	1.527721E+02
8.735040E+01	2.727682E+02	3.220947E+02	2.516335E+02	1.468792E+02
8.935040E+01	2.631675E+02	3.106982E+02	2.474468E+02	1.414696E+02
9.135040E+01	2.543031E+02	3.001802E+02	2.435992E+02	1.365083E+02
9.335040E+01	2.461286E+02	2.904846E+02	2.400674E+02	1.319629E+02
9.535040E+01	2.386000E+02	2.815584E+02	2.368293E+02	1.278029E+02
9.655040E+01	2.343755E+02	2.765510E+02	2.350188E+02	1.254800E+02
9.735040E+01	2.316758E+02	2.733515E+02	2.338642E+02	1.239998E+02
9.935040E+01	2.253167E+02	2.658166E+02	2.311526E+02	1.205271E+02
1.013504E+02	2.194741E+02	2.588956E+02	2.286722E+02	1.173549E+02
1.033504E+02	2.141122E+02	2.525457E+02	2.264054E+02	1.144595E+02
1.053504E+02	2.092093E+02	2.467406E+02	2.243403E+02	1.118249E+02
1.073504E+02	2.047339E+02	2.414429E+02	2.224617E+02	1.094308E+02
1.093504E+02	2.006564E+02	2.366171E+02	2.207556E+02	1.072585E+02
1.113504E+02	1.969487E+02	2.322297E+02	2.192085E+02	1.052905E+02
1.133504E+02	1.935841E+02	2.282490E+02	2.178080E+02	1.035105E+02
1.153504E+02	1.905377E+02	2.246452E+02	2.165424E+02	1.019031E+02
1.173504E+02	1.877857E+02	2.213901E+02	2.154010E+02	1.004544E+02
1.193504E+02	1.853060E+02	2.184573E+02	2.143736E+02	9.915113E+01
1.213504E+02	1.830775E+02	2.158219E+02	2.134509E+02	9.798122E+01
1.233504E+02	1.810806E+02	2.134606E+02	2.126239E+02	9.693332E+01
1.253504E+02	1.792972E+02	2.113520E+02	2.118849E+02	9.599724E+01
1.273504E+02	1.777101E+02	2.094756E+02	2.112263E+02	9.516330E+01
1.293504E+02	1.763033E+02	2.078125E+02	2.106411E+02	9.442266E+01
1.313504E+02	1.750619E+02	2.063450E+02	2.101231E+02	9.376718E+01
1.333504E+02	1.739722E+02	2.050569E+02	2.096664E+02	9.318941E+01
1.353504E+02	1.730214E+02	2.039330E+02	2.092656E+02	9.268246E+01
1.373504E+02	1.721977E+02	2.029593E+02	2.089157E+02	9.224004E+01
1.393504E+02	1.714900E+02	2.021229E+02	2.086122E+02	9.185636E+01
1.413504E+02	1.708883E+02	2.014117E+02	2.083510E+02	9.152614E+01
1.433504E+02	1.703832E+02	2.008148E+02	2.081282E+02	9.124451E+01
1.453504E+02	1.699663E+02	2.003220E+02	2.079403E+02	9.100704E+01
1.473504E+02	1.696294E+02	1.999239E+02	2.077841E+02	9.080967E+01
1.493504E+02	1.693654E+02	1.996119E+02	2.076568E+02	9.064868E+01
1.513504E+02	1.691564E+02	1.993648E+02	2.075517E+02	9.051598E+01
1.533504E+02	1.689955E+02	1.991747E+02	2.074662E+02	9.040789E+01
1.545504E+02	1.689257E+02	1.990923E+02	2.074254E+02	9.035635E+01
1.553504E+02	1.688896E+02	1.990496E+02	2.074024E+02	9.032720E+01
1.573504E+02	1.688336E+02	1.989834E+02	2.073582E+02	9.027137E+01

TABLE 6.2-23 (Cont'd)

DOUBLE-ENDED PUMP SUCTION BREAK MINIMUM SAFEGUARDS REFLOOD
MASS AND ENERGY RELEASES - UNIT 1

TIME (SECONDS)	<u>BREAK PATH NO. 1*</u>		<u>BREAK PATH NO. 2**</u>	
	FLOW (LBM/SEC)	ENERGY (THOUSANDS BTU/SEC)	FLOW (LBM/SEC)	ENERGY (THOUSANDS BTU/SEC)
1.593504E+02	1.688228E+02	1.989706E+02	2.073319E+02	9.023807E+01
1.613504E+02	1.688530E+02	1.990062E+02	2.073217E+02	9.022517E+01
1.633504E+02	1.689201E+02	1.990856E+02	2.073262E+02	9.023071E+01
1.653504E+02	1.690207E+02	1.992045E+02	2.073438E+02	9.025292E+01
1.673504E+02	1.691515E+02	1.993590E+02	2.073734E+02	9.029019E+01
1.693504E+02	1.693094E+02	1.995456E+02	2.074137E+02	9.034103E+01
1.713504E+02	1.694917E+02	1.997611E+02	2.074636E+02	9.040411E+01
1.733504E+02	1.696960E+02	2.000025E+02	2.075224E+02	9.047821E+01
1.753504E+02	1.699200E+02	2.002672E+02	2.075889E+02	9.056222E+01
1.773504E+02	1.701617E+02	2.005528E+02	2.076625E+02	9.065517E+01
1.793504E+02	1.704192E+02	2.008572E+02	2.077425E+02	9.075617E+01
1.813504E+02	1.706909E+02	2.011783E+02	2.078283E+02	9.086441E+01
1.833504E+02	1.709752E+02	2.015143E+02	2.079191E+02	9.097915E+01
1.853504E+02	1.712708E+02	2.018637E+02	2.080146E+02	9.109970E+01
1.873504E+02	1.715764E+02	2.022248E+02	2.081141E+02	9.122547E+01
1.881504E+02	1.717011E+02	2.023723E+02	2.081550E+02	9.127712E+01
1.893504E+02	1.718908E+02	2.025965E+02	2.082174E+02	9.135592E+01
1.913504E+02	1.722132E+02	2.029775E+02	2.083240E+02	9.149057E+01
1.933504E+02	1.725425E+02	2.033668E+02	2.084336E+02	9.162899E+01
1.953504E+02	1.728781E+02	2.037635E+02	2.085458E+02	9.177080E+01
1.973504E+02	1.732193E+02	2.041667E+02	2.086605E+02	9.191567E+01
1.993504E+02	1.735653E+02	2.045757E+02	2.087773E+02	9.206330E+01
2.013504E+02	1.739042E+02	2.049762E+02	2.088923E+02	9.220862E+01
2.033504E+02	1.742345E+02	2.053667E+02	2.090047E+02	9.235060E+01
2.053504E+02	1.745696E+02	2.057628E+02	2.091191E+02	9.249528E+01
2.073504E+02	1.749092E+02	2.061642E+02	2.092357E+02	9.264259E+01
2.093504E+02	1.752532E+02	2.065708E+02	2.093542E+02	9.279241E+01
2.113504E+02	1.756013E+02	2.069824E+02	2.094747E+02	9.294465E+01
2.133504E+02	1.759535E+02	2.073987E+02	2.095970E+02	9.309923E+01
2.153504E+02	1.763096E+02	2.078197E+02	2.097210E+02	9.325608E+01
2.173504E+02	1.766696E+02	2.082453E+02	2.098468E+02	9.341514E+01
2.193504E+02	1.770334E+02	2.086753E+02	2.099743E+02	9.357637E+01
2.213504E+02	1.778216E+02	2.096071E+02	2.103377E+02	9.395698E+01
2.233504E+02	1.787574E+02	2.107134E+02	2.111886E+02	9.445247E+01
2.236504E+02	1.788945E+02	2.108755E+02	2.113527E+02	9.452847E+01

* mass and energy exiting the SG side of the break

** mass and energy exiting the pump side of the break

TABLE 6.2-24

DOUBLE-ENDED PUMP SUCTION BREAK MINIMUM SAFEGUARDS PRINCIPLE PARAMETERS
DURING REFLOOD - UNIT 1

TIME (SECONDS)	<u>FLOODING</u>		CARRYOVER FRACTION (-)	CORE HEIGHT (FT)	DOWNCOMER HEIGHT (FT)	FLOW FRAC (-)	<u>TOTAL INJECTION SPILL</u>			ENTHALPY (BTU/LBM)
	TEMP (°F)	RATE (IN/SEC)					(POUNDS MASS PER SECOND)	ACCUM	PER SECOND)	
24.2	193.3	0.000	0.000	0.00	0.00	0.250	0.0	0.0	0.0	0.00
25.1	189.9	20.855	0.000	0.73	1.24	0.000	6645.8	6645.8	0.0	89.66
25.2	189.2	21.349	0.000	0.91	1.18	0.000	6623.9	6623.9	0.0	89.66
25.3	188.5	20.823	0.000	1.08	1.11	0.000	6602.2	6602.2	0.0	89.66
25.6	188.0	2.323	0.104	1.31	1.64	0.186	6509.5	6509.5	0.0	89.66
25.8	188.0	2.679	0.138	1.35	2.17	0.225	6468.3	6468.3	0.0	89.66
26.8	188.2	2.339	0.307	1.50	4.71	0.326	6267.5	6267.5	0.0	89.66
28.2	188.6	2.280	0.457	1.67	8.40	0.350	6014.1	6014.1	0.0	89.66
31.8	189.8	3.815	0.633	2.00	16.08	0.562	5164.1	5164.1	0.0	89.66
32.3	189.9	3.914	0.649	2.06	16.12	0.562	5007.0	5007.0	0.0	89.66
34.3	190.6	3.643	0.688	2.27	16.12	0.559	4769.7	4769.7	0.0	89.66
37.0	191.8	3.398	0.712	2.50	16.12	0.553	4512.9	4512.9	0.0	89.66
43.3	195.4	3.056	0.734	2.96	16.12	0.538	4028.5	4028.5	0.0	89.66
43.9	195.7	3.225	0.737	3.00	16.12	0.556	4435.6	3907.0	0.0	87.69
51.4	200.7	2.965	0.745	3.50	16.12	0.542	4003.1	3468.1	0.0	87.45

TABLE 6.2-24 (Cont'd)

DOUBLE-ENDED PUMP SUCTION BREAK MINIMUM SAFEGUARDS PRINCIPLE
PARAMETERS DURING REFLOOD - UNIT 1

TIME (SECONDS)	<u>FLOODING</u>		CARRYOVER FRACTION (-)	CORE HEIGHT (FT)	DOWNCOMER HEIGHT (FT)	FLOW FRAC (-)	TOTAL	INJECTION ACCUM	SPILL	ENTHALPY (BTU/LBM)
	TEMP (°F)	RATE (IN/SEC)					(POUNDS MASS PER SECOND)	PER SECOND)	SECOND)	
59.8	206.5	2.755	0.750	4.00	16.12	0.528	3624.8	3084.0	0.0	87.20
65.4	210.4	2.411	0.750	4.32	16.12	0.486	2795.6	2243.8	0.0	86.40
66.4	211.1	3.389	0.755	4.37	16.00	0.598	515.4	0.0	0.0	73.14
67.4	211.9	3.443	0.755	4.44	15.76	0.601	509.1	0.0	0.0	73.14
68.4	212.8	3.366	0.756	4.51	15.52	0.599	511.7	0.0	0.0	73.14
76.2	219.9	2.844	0.755	5.00	14.01	0.588	528.2	0.0	0.0	73.14
87.4	230.5	2.335	0.755	5.59	12.72	0.571	541.6	0.0	0.0	73.14
96.6	237.7	2.058	0.754	6.00	12.18	0.557	548.0	0.0	0.0	73.14
109.4	245.7	1.815	0.755	6.51	11.93	0.541	553.0	0.0	0.0	73.14
123.4	252.8	1.672	0.756	7.00	12.03	0.529	555.6	0.0	0.0	73.14
139.4	259.5	1.595	0.760	7.53	12.41	0.522	556.9	0.0	0.0	73.14
154.6	264.8	1.567	0.765	8.00	12.88	0.521	557.3	0.0	0.0	73.14
171.4	269.8	1.558	0.771	8.51	13.44	0.521	557.3	0.0	0.0	73.14
175.4	270.9	1.558	0.773	8.63	13.58	0.522	557.2	0.0	0.0	73.14
188.2	274.1	1.559	0.777	9.00	14.02	0.523	557.0	0.0	0.0	73.14
207.4	278.3	1.566	0.785	9.55	14.69	0.526	556.7	0.0	0.0	73.14
223.7	281.3	1.579	0.791	10.00	15.24	0.529	556.3	0.0	0.0	73.14

TABLE 6.2-25

DOUBLE-ENDED PUMP SUCTION BREAK MINIMUM SAFEGUARDS POST-REFLOOD
MASS AND ENERGY RELEASES - UNIT 1

TIME (SECONDS)	<u>BREAK PATH NO. 1*</u>		<u>BREAK PATH NO. 2**</u>	
	FLOW (LBM/SEC)	ENERGY (THOUSANDS BTU/SEC)	FLOW (LBM/SEC)	ENERGY (THOUSANDS BTU/SEC)
2.237000E+02	2.195729E+02	2.749315E+02	3.468448E+02	1.307437E+02
2.287000E+02	2.200155E+02	2.754857E+02	3.464022E+02	1.304477E+02
2.337000E+02	2.190720E+02	2.743043E+02	3.473457E+02	1.305109E+02
2.387000E+02	2.181242E+02	2.731176E+02	3.482935E+02	1.305750E+02
2.437000E+02	2.185176E+02	2.736102E+02	3.479001E+02	1.302909E+02
2.487000E+02	2.175465E+02	2.723942E+02	3.488712E+02	1.303604E+02
2.537000E+02	2.179010E+02	2.728381E+02	3.485167E+02	1.300858E+02
2.587000E+02	2.169056E+02	2.715917E+02	3.495121E+02	1.301609E+02
2.637000E+02	2.172195E+02	2.719848E+02	3.491982E+02	1.298962E+02
2.687000E+02	2.161984E+02	2.707063E+02	3.502192E+02	1.299774E+02
2.737000E+02	2.164706E+02	2.710471E+02	3.499471E+02	1.297229E+02
2.787000E+02	2.167134E+02	2.713510E+02	3.497043E+02	1.294757E+02
2.837000E+02	2.156437E+02	2.700117E+02	3.507740E+02	1.295686E+02
2.887000E+02	2.158415E+02	2.702593E+02	3.505762E+02	1.293324E+02
2.937000E+02	2.147434E+02	2.688843E+02	3.516743E+02	1.294320E+02
2.987000E+02	2.148945E+02	2.690736E+02	3.515231E+02	1.292074E+02
3.037000E+02	2.150131E+02	2.692221E+02	3.514046E+02	1.289908E+02
3.087000E+02	2.138605E+02	2.677789E+02	3.525572E+02	1.291036E+02
3.137000E+02	2.139291E+02	2.678648E+02	3.524886E+02	1.288994E+02
3.187000E+02	2.139630E+02	2.679072E+02	3.524547E+02	1.287039E+02
3.237000E+02	2.127515E+02	2.663903E+02	3.536662E+02	1.288310E+02
3.287000E+02	2.127314E+02	2.663651E+02	3.536863E+02	1.286488E+02
3.337000E+02	2.126762E+02	2.662960E+02	3.537415E+02	1.284755E+02
3.387000E+02	2.125861E+02	2.661832E+02	3.538316E+02	1.283108E+02
3.437000E+02	2.112829E+02	2.645514E+02	3.551348E+02	1.284605E+02
3.487000E+02	2.111277E+02	2.643571E+02	3.552900E+02	1.283120E+02
3.537000E+02	2.109308E+02	2.641105E+02	3.554869E+02	1.281742E+02
3.587000E+02	2.106921E+02	2.638117E+02	3.557256E+02	1.280467E+02
3.637000E+02	2.104087E+02	2.634568E+02	3.560090E+02	1.279306E+02
3.687000E+02	2.100812E+02	2.630467E+02	3.563365E+02	1.278255E+02
3.737000E+02	2.097057E+02	2.625766E+02	3.567119E+02	1.277327E+02

TABLE 6.2-25 (Cont'd)

DOUBLE-ENDED PUMP SUCTION BREAK MINIMUM SAFEGUARDS POST-REFLOOD
MASS AND ENERGY RELEASES - UNIT 1

TIME (SECONDS)	<u>BREAK PATH NO. 1*</u>		<u>BREAK PATH NO. 2**</u>	
	FLOW (LBM/SEC)	ENERGY (THOUSANDS BTU/SEC)	FLOW (LBM/SEC)	ENERGY (THOUSANDS BTU/SEC)
3.787000E+02	2.092833E+02	2.620477E+02	3.571344E+02	1.276516E+02
3.837000E+02	2.088097E+02	2.614547E+02	3.576080E+02	1.275835E+02
3.887000E+02	2.082856E+02	2.607985E+02	3.581320E+02	1.275281E+02
3.937000E+02	2.077070E+02	2.600740E+02	3.587106E+02	1.274866E+02
3.987000E+02	2.081180E+02	2.605886E+02	3.582997E+02	1.271881E+02
4.037000E+02	2.075149E+02	2.598334E+02	3.589028E+02	1.271585E+02
4.087000E+02	2.068907E+02	2.590519E+02	3.595269E+02	1.271361E+02
4.137000E+02	2.062044E+02	2.581925E+02	3.602133E+02	1.271296E+02
4.187000E+02	2.064395E+02	2.584869E+02	3.599782E+02	1.268837E+02
4.237000E+02	2.055896E+02	2.574227E+02	3.608281E+02	1.269190E+02
4.287000E+02	2.056250E+02	2.574671E+02	3.607927E+02	1.267242E+02
4.337000E+02	2.055378E+02	2.573579E+02	3.608799E+02	1.265610E+02
4.387000E+02	2.053233E+02	2.570893E+02	3.610944E+02	1.264304E+02
4.437000E+02	2.049690E+02	2.566457E+02	3.614487E+02	1.263357E+02
4.487000E+02	2.044716E+02	2.560228E+02	3.619461E+02	1.262778E+02
4.537000E+02	2.038228E+02	2.552105E+02	3.625948E+02	1.262588E+02
4.587000E+02	2.038625E+02	2.552602E+02	3.625552E+02	1.260609E+02
4.637000E+02	2.028344E+02	2.539729E+02	3.635833E+02	1.261396E+02
4.687000E+02	2.024357E+02	2.534737E+02	3.639820E+02	1.260548E+02
4.737000E+02	2.025578E+02	2.536265E+02	3.638599E+02	1.258344E+02
4.787000E+02	2.023206E+02	2.533296E+02	3.640971E+02	1.257070E+02
4.837000E+02	2.016907E+02	2.525408E+02	3.647270E+02	1.256810E+02
4.887000E+02	2.013421E+02	2.521043E+02	3.650756E+02	1.255818E+02
4.937000E+02	2.011080E+02	2.518112E+02	3.653097E+02	1.254524E+02
4.987000E+02	2.007980E+02	2.514231E+02	3.656197E+02	1.253424E+02
5.037000E+02	2.001640E+02	2.506293E+02	3.662536E+02	1.253161E+02
5.087000E+02	2.000496E+02	2.504860E+02	3.663680E+02	1.251547E+02
5.137000E+02	1.991116E+02	2.493116E+02	3.673060E+02	1.252065E+02
5.187000E+02	1.988844E+02	2.490271E+02	3.675332E+02	1.250736E+02
5.237000E+02	1.985986E+02	2.486691E+02	3.678191E+02	1.249556E+02
5.287000E+02	1.981173E+02	2.480666E+02	3.683003E+02	1.248878E+02
6.992170E+02	1.981173E+02	2.480666E+02	3.683003E+02	1.248878E+02
6.993170E+02	9.616161E+01	1.194631E+02	4.702561E+02	1.519177E+02
7.037000E+02	9.604013E+01	1.193110E+02	4.703776E+02	1.517513E+02
1.108700E+03	8.719153E+01	1.082315E+02	4.792261E+02	1.445971E+02
1.110000E+03	8.717064E+01	1.082053E+02	3.425194E+02	1.675419E+02
1.757368E+03	8.717064E+01	1.082053E+02	3.425194E+02	1.675419E+02
1.757468E+03	7.754533E+01	8.922495E+01	3.521447E+02	7.943032E+01
3.000000E+03	6.844378E+01	7.875255E+01	3.612462E+02	8.107238E+01
3.000100E+03	6.844314E+01	7.875182E+01	3.612469E+02	7.978343E+01
3.600000E+03	6.465374E+01	7.439167E+01	3.650363E+02	8.046710E+01

TABLE 6.2-25 (Cont'd)

DOUBLE-ENDED PUMP SUCTION BREAK MINIMUM SAFEGUARDS POST-REFLOOD
MASS AND ENERGY RELEASES - UNIT 1

TIME (SECONDS)	<u>BREAK PATH NO. 1*</u>		<u>BREAK PATH NO. 2**</u>	
	FLOW (LBM/SEC)	ENERGY (THOUSANDS BTU/SEC)	FLOW (LBM/SEC)	ENERGY (THOUSANDS BTU/SEC)
3.600100E+03	5.352215E+01	6.158348E+01	3.761678E+0	5.529667E+01
1.000000E+04	3.891924E+01	4.478112E+01	3.907708E+0	5.744330E+01
1.000010E+04	3.801020E+01	4.373517E+01	3.916798E+0	4.817662E+01
1.000000E+05	2.032142E+01	2.338217E+01	4.093686E+0	5.035233E+01
1.000001E+05	1.981995E+01	2.280516E+01	4.098701E+0	3.975739E+01
1.000000E+06	8.492855E+00	9.772021E+00	4.211971E+0	4.085612E+01
1.000000E+06	8.460734E+00	9.735062E+00	4.212293E+0	3.917432E+01
1.000000E+07	2.649718E+00	3.048810E+00	4.270403E+0	3.971475E+01

* mass and energy exiting the SG side of the break

** mass and energy exiting the pump side of the break

TABLE 6.2-26

DOUBLE-ENDED PUMP SUCTION BREAK MASS BALANCE MINIMUM
SAFEGUARDS - UNIT 1

TIME (SECONDS)		MASS BALANCE						
		0.00	24.20	24.20	223.65	699.32	1757.37	3600.00
		MASS (THOUSAND LBM)						
Initial	In RCS and ACC	816.31	816.31	816.31	816.31	816.31	816.31	816.31
Added Mass	Pumped Injection	0.00	0.00	0.00	98.99	368.39	879.17	1670.93
	Total Added	0.00	0.00	0.00	98.99	368.39	879.17	1670.93
TOTAL AVAILABLE		816.31	816.31	816.31	915.30	1184.70	1695.48	2487.24
Distribution	Reactor Coolant	567.44	56.68	79.68	141.19	141.19	141.19	141.19
	Accumulator	248.87	194.11	171.11	-0.00	0.00	0.00	0.00
	Total Contents	816.31	250.79	250.79	141.19	141.19	141.19	141.19
Effluent	Break Flow	0.00	565.52	565.52	762.50	1031.90	1542.60	2334.36
	ECCS Spill	0.00	0.00	0.00	0.00	0.00	0.00	0.00
	Total Effluent	0.00	565.52	565.52	762.50	1031.90	1542.60	2334.36
TOTAL ACCOUNTABLE		816.31	816.31	816.31	903.69	1173.09	1683.78	2475.54

TABLE 6.2-27

DOUBLE-ENDED PUMP SUCTION BREAK ENERGY BALANCE MINIMUM
SAFEGUARDS - UNIT 1

TIME (SECONDS)	ENERGY BALANCE						
	0.00	24.20	24.20	223.65	699.32	1757.37	3600.00
Initial Energy	ENERGY (MILLION BTU)						
In RCS, ACC, S GEN	968.81	968.81	968.81	968.81	968.81	968.81	968.81
Added Energy							
Pumped Injection	0.00	0.00	0.00	7.24	26.94	85.68	203.67
Decay Heat	0.00	7.91	7.91	32.31	76.50	154.62	263.36
Heat From Secondary	0.00	16.09	16.09	16.09	16.09	16.09	16.09
Total Added	0.00	24.00	24.00	55.64	119.54	256.39	483.12
TOTAL AVAILABLE	968.81	992.81	992.81	1024.45	1088.35	1222.20	1451.93
Distribution							
Reactor Coolant	341.62	12.82	14.88	37.20	37.20	37.20	37.20
Accumulator Core	22.27	17.37	15.31	.00	0.00	0.00	0.00
Stored Primary	23.64	12.20	12.20	4.77	4.71	4.20	3.33
Metal Secondary	177.44	169.29	169.29	132.91	97.27	69.02	51.77
Metal Steam	91.73	91.44	91.44	83.94	67.41	43.62	31.85
Generator	312.11	330.54	330.54	297.20	230.93	146.03	105.95
Total Contents	968.81	633.66	633.66	556.01	437.52	300.07	230.09
<u>Effluent</u>							
Break Flow	0.00	358.58	358.58	446.80	629.19	915.45	1213.56
ECCS Spill	0.00	0.00	0.00	0.00	0.00	0.00	0.00
Total Effluent	0.00	358.58	358.58	446.80	629.19	915.45	1213.56
TOTAL ACCOUNTABLE	968.81	992.24	992.24	1002.81	1066.71	1215.52	1443.65

B/B-UFSAR

TABLE 6.2-28

DOUBLE-ENDED PUMP SUCTION BREAK MAXIMUM SAFEGUARDS BLOWDOWN MASS
AND ENERGY RELEASES - UNIT 1

<u>Time</u> (sec)	<u>Break Path No. 1*</u>		<u>Break Path No. 2**</u>	
	<u>Flow</u> (lbm/sec)	<u>Energy</u> (1000 BTU/sec)	<u>Flow</u> (lbm/sec)	<u>Energy</u> (1000 BTU/sec)
0.00000	0.0	0.0	0.0	0.0
0.00111	84856.4	47801.1	43218.0	24297.4
0.101	42559.9	23971.4	22324.8	12538.6
0.201	42838.3	24219.8	24793.7	13937.7
0.302	43224.9	24558.8	24956.9	14042.5
0.402	43629.3	24936.1	24131.6	13591.6
0.502	44059.6	25358.0	23018.1	12973.9
0.601	44503.7	25817.0	22086.5	12453.8
0.701	44766.3	26186.9	21271.1	11996.9
0.801	44702.0	26364.3	20677.2	11664.8
0.902	44293.3	26328.8	20266.8	11437.2
1.00	43606.9	26110.9	20049.6	11317.6
1.10	42759.5	25784.9	19935.4	11255.1
1.20	41898.8	25438.2	19892.2	11231.9
1.30	41061.4	25101.1	19871.4	11220.8
1.40	40249.1	24776.4	19861.7	11215.1
1.50	39450.6	24454.2	19880.1	11225.2
1.60	38642.2	24124.2	19935.6	11256.3
1.70	37855.4	23803.0	20000.0	11292.4
1.80	37099.3	23496.8	20046.8	11318.2
1.90	36353.5	23197.3	20070.2	11330.6
2.00	35584.0	22881.8	20050.4	11318.4
2.10	24788.4	22551.9	20008.5	11293.7
2.20	33983.5	22215.3	19932.5	11249.8
2.30	33099.2	21822.8	19755.4	11148.0
2.40	32225.5	21434.5	19361.7	10924.0
2.50	31325.8	21022.5	19185.7	10824.3
2.60	30441.3	20611.5	19038.8	10740.8
2.70	29572.6	20200.4	18854.7	10635.9
2.80	28678.3	19758.4	18628.6	10507.2
2.90	27509.7	19107.6	18400.1	10377.3
3.00	25599.5	17911.0	18203.1	10265.6
3.10	23103.9	16272.7	18016.5	10160.0
3.20	22045.5	15653.9	17811.6	10043.9
3.30	21224.3	15157.2	17595.1	9921.2
3.40	20058.5	14380.3	17405.2	9814.0
3.50	19288.0	13883.3	17237.8	9719.7

B/B-UFSAR

TABLE 6.2-28 (Cont'd)

DOUBLE-ENDED PUMP SUCTION BREAK MAXIMUM SAFEGUARDS BLOWDOWN MASS
AND ENERGY RELEASES - UNIT 1

Time (sec)	<u>Break Path No. 1*</u>		<u>Break Path No. 2**</u>	
	Flow (lbm/sec)	Energy (1000 BTU/sec)	Flow (lbm/sec)	Energy (1000 BTU/sec)
3.60	18601.3	13430.8	17074.0	9627.5
3.70	17924.0	12974.3	16909.1	9534.8
3.80	17326.2	12570.4	16750.6	9444.7
3.90	16806.1	12218.4	16610.9	9363.1
4.00	16348.7	11908.1	16483.5	9287.8
4.20	15583.5	11384.6	16246.6	9149.5
4.40	15011.5	10988.0	16030.4	9024.5
4.60	14536.4	10650.0	15823.0	8904.5
4.80	14180.7	10389.6	15640.0	8799.1
5.00	13898.4	10171.3	15460.1	8696.8
5.20	13707.0	10009.6	15287.4	8600.1
5.40	13584.4	9887.5	15108.5	8501.5
5.60	13536.4	9810.5	14928.2	8403.1
5.80	13561.8	9777.2	14753.1	8308.4
6.00	13687.6	9806.4	14588.4	8220.1
6.20	14046.6	9992.4	14163.8	7983.7
6.40	13823.6	9748.1	15264.5	8622.7
6.60	13837.2	9861.2	15698.9	8863.1
6.80	12864.8	9629.3	15551.5	8786.2
7.00	11792.7	9136.4	15477.6	8748.4
7.20	11895.0	9150.7	15256.8	8626.0
7.40	12353.9	9364.7	14994.7	8480.4
7.60	12688.5	9505.4	14864.6	8408.9
7.80	13046.4	9674.0	14692.3	8311.1
8.00	13658.2	10006.0	14424.1	8156.9
8.20	14010.7	10113.0	14196.0	8024.4
8.40	13232.0	9447.0	14053.1	7940.2
8.60	11978.7	8556.2	14036.9	7928.0
8.80	11808.4	8473.5	13999.9	7902.8
9.00	11990.9	8569.8	13697.4	7726.3
9.20	11695.6	8326.8	13551.6	7639.5
9.40	11386.8	8127.9	13625.3	7678.3
9.60	11504.0	8226.8	13450.5	7575.6
9.80	11557.4	8236.0	13121.3	7385.6
10.0	11241.7	7986.7	13102.2	7372.7
10.2	11049.1	7859.2	13097.0	7367.7
10.4	11077.6	7874.9	12758.1	7173.1
10.6	10562.4	7501.7	12647.7	7109.1
10.8	10036.8	7179.6	12822.0	7207.0
11.0	9906.9	7144.3	12482.2	7011.9
11.2	9631.2	6995.6	12309.8	6912.8
11.4	9388.7	6877.5	12447.3	6989.5
11.6	9227.6	6800.4	12127.3	6805.9

B/B-UFSAR

TABLE 6.2-28 (Cont'd)

DOUBLE-ENDED PUMP SUCTION BREAK MAXIMUM SAFEGUARDS BLOWDOWN MASS
AND ENERGY RELEASES - UNIT 1

Time (sec)	<u>Break Path No. 1*</u>		<u>Break Path No. 2**</u>	
	Flow (lbm/sec)	Energy (1000 BTU/sec)	Flow (lbm/sec)	Energy (1000 BTU/sec)
11.8	9023.2	6678.0	12015.1	6741.3
12.0	8902.4	6607.4	12028.7	6747.7
12.2	8743.0	6500.3	11752.6	6589.9
12.4	8585.2	6402.5	11733.5	6578.5
12.6	8447.1	6319.1	11611.2	6508.1
12.8	8267.8	6210.9	11460.5	6422.2
13.0	8129.3	6138.5	11409.1	6392.6
13.2	7969.6	6049.7	11252.9	6303.6
13.4	7828.2	5976.2	11176.3	6260.1
13.6	7694.0	5903.4	11048.1	6187.4
13.8	7562.6	5829.5	10950.2	6132.2
14.0	7444.9	5762.2	10834.4	6067.1
14.2	7324.4	5690.5	10725.0	6005.9
14.4	7207.1	5621.6	10605.1	5939.2
14.6	7077.9	5544.8	10470.7	5864.6
14.8	6939.4	5463.2	10342.1	5793.6
15.0	6795.7	5378.3	10205.2	5718.6
15.2	6655.2	5293.0	10082.0	5651.7
15.4	6526.2	5210.3	9955.8	5583.7
15.6	6414.4	5134.6	9840.0	5522.0
15.8	6317.2	5065.3	9724.3	5460.9
16.0	6231.6	5003.2	9612.3	5402.4
16.2	6152.1	4946.7	9504.2	5346.8
16.4	6073.7	4894.6	9395.1	5291.4
16.6	5995.1	4847.6	9290.8	5239.6
16.8	5913.8	4805.4	9184.9	5187.8
17.0	5828.1	4768.1	9079.8	5137.7
17.2	5738.5	4738.3	8977.7	5090.8
17.4	5646.2	4712.3	8856.7	5035.5
17.6	5563.9	4706.1	8745.5	4991.5
17.8	5488.5	4731.4	8449.4	4856.2
18.0	5371.3	4768.5	8188.2	4741.8
18.2	5186.1	4789.8	7999.0	4663.5
18.4	4881.6	4726.5	4720.9	4348.4
18.6	4537.8	4639.1	7143.8	4197.8
18.8	4203.4	4537.1	6821.8	3967.7
19.0	3878.9	4404.3	6529.8	3716.0
19.2	3586.7	4234.7	6310.8	3482.1
19.6	3088.1	3788.5	5781.0	2977.3
19.8	2858.5	3528.6	5479.2	2744.9
20.0	2652.5	3288.7	5191.4	2544.2
20.2	2461.0	3062.0	4909.9	2359.5
20.6	2123.5	2656.6	4401.7	2044.1
20.8	1972.2	2472.9	4194.7	1918.7

B/B-UFSAR

TABLE 6.2-28 (Cont'd)

DOUBLE-ENDED PUMP SUCTION BREAK MAXIMUM SAFEGUARDS BLOWDOWN MASS
AND ENERGY RELEASES - UNIT 1

Time (sec)	<u>Break Path No. 1*</u>		<u>Break Path No. 2**</u>	
	Flow (lbm/sec)	Energy (1000 BTU/sec)	Flow (lbm/sec)	Energy (1000 BTU/sec)
21.0	1839.8	2311.5	3992.9	1800.1
21.2	1716.5	2160.7	3804.3	1692.1
21.6	1536.2	1940.0	2962.1	1248.6
21.8	1455.5	1840.0	2632.3	1055.6
22.0	1361.9	1723.7	2770.9	1059.7
22.2	1268.5	1607.5	2812.2	1046.2
22.4	1176.9	1493.3	2960.1	1081.2
22.6	1090.6	1385.0	3358.3	1205.5
22.8	1000.0	1272.0	3111.1	1102.2
23.0	914.5	1164.5	2545.1	896.8
23.2	834.9	1064.1	2356.6	827.9
23.4	761.4	971.2	2072.6	725.1
23.6	694.4	886.3	1792.1	625.0
23.8	629.7	804.2	1432.6	499.5
24.0	588.9	752.7	1245.3	433.4
24.2	555.5	710.4	1023.9	350.6
24.4	511.1	653.8	714.4	240.5
24.6	468.8	600.0	445.6	148.2
24.8	433.5	555.1	261.8	85.1
25.0	403.2	516.6	0.0	0.0
25.2	360.3	461.7	0.0	0.0
25.4	328.9	421.7	0.0	0.0
25.6	283.5	363.6	0.0	0.0
25.8	230.0	295.2	0.0	0.0
26.0	205.3	263.6	0.0	0.0
26.2	149.9	192.6	0.0	0.0
26.4	98.1	126.3	0.0	0.0
26.6	49.9	64.4	0.0	0.0
26.8	0.0	0.0	0.0	0.0

* mass and energy exiting the SG side of the break

** mass and energy exiting the pump side of the break

B/B-UFSAR

TABLE 6.2-29

DOUBLE-ENDED PUMP SUCTION BREAK MAXIMUM SAFEGUARDS REFLOOD MASS
AND ENERGY RELEASES - UNIT 1

Time (sec)	<u>Break Path No. 1*</u>		<u>Break Path No. 2**</u>	
	Flow (lbm/sec)	Energy (1000 BTU/sec)	Flow (lbm/sec)	Energy (1000 BTU/sec)
26.8	0.0	0.0	0.0	0.0
27.4	0.0	0.0	0.0	0.0
27.6	0.0	0.0	0.0	0.0
27.7	0.0	0.0	0.0	0.
27.8	0.0	0.0	0.0	0.0
27.9	0.0	0.0	0.0	0.0
28.0	7.4	8.8	0.0	0.0
28.1	46.9	55.3	0.0	0.0
28.2	18.7	22.1	0.0	0.0
28.3	12.6	14.8	0.0	0.0
28.4	14.4	16.9	0.0	0.0
28.5	20.0	23.6	0.0	0.0
28.6	26.6	31.4	0.0	0.0
28.7	34.5	40.7	0.0	0.0
28.8	39.5	46.5	0.0	0.0
28.9	44.7	52.7	0.0	0.0
29.0	48.5	57.2	0.0	0.0
29.1	52.1	61.4	0.0	0.0
29.2	55.5	65.5	0.0	0.0
29.3	58.8	69.4	0.0	0.0
29.4	62.0	73.1	0.0	0.0
29.5	63.5	74.9	0.0	0.0
29.5	65.1	76.7	0.0	0.0
29.6	68.0	80.2	0.0	0.0
29.7	70.9	83.6	0.0	0.0
29.8	73.7	86.9	0.0	0.0
30.8	98.0	115.6	0.0	0.0
31.8	118.0	139.2	0.0	0.0
32.8	142.5	168.2	422.7	37.2
33.8	181.8	214.6	1079.2	130.1
34.3	432.6	512.9	4323.7	628.5
34.9	489.2	580.6	4863.7	734.2
35.9	490.5	582.2	4871.6	742.6
36.9	484.9	575.5	4821.3	737.0
37.9	478.6	568.0	4765.0	730.2
38.6	474.2	562.7	4724.2	725.1
38.9	472.3	560.4	4706.6	722.9
39.9	465.9	552.8	4647.8	715.5

B/B-UFSAR

TABLE 6.2-29 (Cont'd)

DOUBLE-ENDED PUMP SUCTION BREAK MAXIMUM SAFEGUARDS REFLOOD MASS
AND ENERGY RELEASES - UNIT 1

Time (sec)	Break Path No. 1*		Break Path No. 2**	
	Flow (lbm/sec)	Energy (1000 BTU/sec)	Flow (lbm/sec)	Energy (1000 BTU/sec)
40.9	459.7	545.4	4589.5	708.0
41.9	453.6	538.1	4532.2	700.7
42.9	447.7	531.0	4476.1	693.4
43.9	442.0	524.2	4421.3	686.3
44.0	441.4	523.5	4415.8	685.6
44.9	436.5	517.6	4367.8	679.3
45.9	431.1	511.1	4315.7	672.5
46.9	425.9	504.9	4265.1	665.9
47.9	420.9	498.9	4215.7	659.4
48.9	416.0	493.1	4167.7	653.2
49.9	411.3	487.5	4121.0	647.0
50.2	409.9	485.8	4107.2	645.2
50.9	406.7	482.0	4075.4	641.0
51.9	402.3	476.7	4031.1	635.2
52.9	398.0	471.6	3987.8	629.5
53.9	393.8	466.6	3945.7	623.9
54.9	389.7	461.7	3904.6	618.5
55.9	385.8	457.0	3864.4	613.2
56.9	381.9	452.4	3825.3	608.0
57.0	381.6	452.0	3821.4	607.5
57.9	378.2	448.0	3787.0	602.9
58.9	374.6	443.6	3749.6	598.0
59.9	371.0	439.4	3713.1	593.1
60.9	367.5	435.3	3677.3	588.3
61.9	364.1	431.2	3642.3	583.7
62.9	360.8	427.3	3608.1	579.1
63.9	357.6	423.4	3574.6	574.6
64.9	354.4	419.7	3541.8	570.2
65.9	351.3	416.0	3509.6	565.8
66.9	348.3	412.4	3478.1	561.6
67.9	345.3	408.8	3447.1	557.4
68.9	342.4	405.4	3416.8	553.3
69.9	339.6	402.0	3387.0	549.2
70.9	336.8	398.6	3357.8	545.2
71.9	334.0	395.4	3329.1	541.3
72.0	333.8	395.0	3326.3	540.9
72.9	331.3	392.2	3300.9	537.4
73.9	328.7	389.0	3273.2	533.6
74.9	326.1	385.9	3246.0	529.9
75.9	323.5	382.9	3219.2	526.2
76.9	321.0	379.9	3192.9	522.5
77.9	318.5	376.9	3167.0	519.0
78.9	181.5	214.2	1332.4	279.2
79.9	180.8	213.4	1334.0	278.9

B/B-UFSAR

TABLE 6.2-29 (Cont'd)

DOUBLE-ENDED PUMP SUCTION BREAK MAXIMUM SAFEGUARDS REFLOOD MASS
AND ENERGY RELEASES - UNIT 1

Time (sec)	Break Path No. 1*		Break Path No. 2**	
	Flow (lbm/sec)	Energy (1000 BTU/sec)	Flow (lbm/sec)	Energy (1000 BTU/sec)
80.9	180.5	213.1	1334.6	278.8
81.9	180.2	212.8	1335.2	278.6
82.9	179.9	212.4	1335.8	278.5
83.9	179.7	212.1	1336.5	278.3
84.9	179.4	211.8	1337.1	278.2
85.9	179.2	211.5	1337.8	278.0
86.9	178.9	211.2	1338.5	277.9
87.9	178.6	210.9	1339.1	277.8
89.9	178.1	210.3	1340.5	277.5
91.7	177.7	209.8	1341.7	277.2
91.9	177.6	209.7	1341.8	277.2
93.9	177.1	209.1	1343.2	276.9
95.9	176.6	208.5	1344.6	276.6
97.9	176.1	207.9	1345.9	276.4
99.9	175.6	207.4	1347.3	276.1
101.9	175.2	206.8	1348.7	275.8
103.9	174.7	206.2	1350.1	275.5
105.9	174.2	205.6	1351.5	275.2
107.9	173.7	205.1	1352.9	275.0
109.9	173.2	404.5	1354.3	274.7
111.9	172.8	204.0	1355.7	274.4
113.9	172.3	203.4	1357.0	274.1
114.9	172.1	203.1	1357.7	274.0
115.9	171.8	202.9	1358.4	273.8
117.9	171.4	202.3	1359.8	273.5
119.9	170.9	201.8	1361.1	273.2
121.9	170.5	201.2	1362.5	272.9
123.9	170.0	200.7	1363.8	272.6
125.9	169.5	200.1	1365.1	272.3
127.9	169.1	199.6	1366.5	272.0
129.9	168.6	199.1	1367.8	271.6
131.9	168.2	198.5	1369.1	271.3
133.9	167.8	198.0	1370.4	271.0
135.9	167.3	197.5	1371.6	270.7
137.9	166.9	197.0	1372.9	270.3
139.9	166.4	196.5	1374.2	270.0
140.1	166.4	196.4	1374.3	270.0
141.9	166.0	196.0	1375.4	269.6
143.9	165.6	195.4	1376.7	269.3
145.9	165.1	194.9	1377.9	268.9
147.9	164.7	194.4	1379.2	268.6
149.9	164.3	193.9	1380.4	268.2
151.9	163.9	193.4	1381.6	267.9
153.9	163.4	192.9	1382.8	267.5

B/B-UFSAR

TABLE 6.2-29 (Cont'd)

DOUBLE-ENDED PUMP SUCTION BREAK MAXIMUM SAFEGUARDS REFLOOD MASS
AND ENERGY RELEASES - UNIT 1

Time (sec)	Break Path No. 1*		Break Path No. 2**	
	Flow (lbm/sec)	Energy (1000 BTU/sec)	Flow (lbm/sec)	Energy (1000 BTU/sec)
155.9	163.0	192.4	1384.0	267.2
157.9	162.6	191.9	1385.2	266.8
159.9	162.2	191.4	1386.4	266.4
161.9	161.8	190.9	1387.6	266.0
163.9	161.4	190.5	1388.8	265.7
165.9	161.0	190.0	1390.0	265.3
167.5	160.6	189.6	1390.9	265.0
167.9	160.5	189.5	1391.2	264.9
169.9	160.1	189.0	1392.3	264.5
171.9	159.7	188.5	1393.5	264.1
173.9	159.3	188.1	1394.6	263.7
175.9	158.9	187.6	1395.8	263.3
177.9	158.5	187.1	1396.9	262.9
179.9	158.2	186.7	1398.1	262.5
181.9	157.8	186.2	1399.2	262.1
183.9	157.4	185.7	1400.3	261.7
185.9	157.0	185.3	1401.4	261.3
187.9	156.6	184.8	1402.5	260.9
189.9	156.2	184.4	1403.6	260.5
191.9	155.9	183.9	1404.7	260.1
193.9	155.5	183.5	1405.8	259.7
195.9	155.1	183.1	1406.9	259.3
197.7	154.8	182.7	1407.9	258.9

* mass and energy exiting the SG side of the break

** mass and energy exiting the pump side of the break

B/B-UFSAR

TABLE 6.2-30

DOUBLE-ENDED PUMP SUCTION BREAK - MAXIMUM SAFEGUARDS PRINCIPLE
PARAMETERS DURING REFLOOD - UNIT 1

<u>Time</u> <u>(sec)</u>	<u>Flooding</u>				<u>Flow (lbm/sec)</u>					<u>Enthalpy</u> <u>(BTU/lbm)</u>
	<u>Temp</u> <u>(°F)</u>	<u>Rate</u> <u>(in/sec)</u>	<u>Carryover</u> <u>Fractio</u> <u>n</u>	<u>Core</u> <u>Height</u> <u>(ft)</u>	<u>Downcomer</u> <u>Height</u> <u>(ft)</u>	<u>Flow</u> <u>Fracti</u> <u>on</u>	<u>Total</u>	<u>Injection</u> <u>Accum</u>	<u>Spill</u>	
26.8	180.8	0.000	0.000	0.00	0.00	0.250	0.0	0.0	0.0	0.00
27.6	179.0	8.407	0.000	0.53	1.18	0.000	6203.3	6203.3	0.0	99.46
27.8	178.0	9.878	0.000	0.85	1.08	0.000	6162.1	6162.1	0.0	99.46
27.9	177.5	9.477	0.000	1.01	1.02	0.000	6141.8	6141.8	0.0	99.46
28.3	177.1	1.765	0.101	1.31	1.58	0.250	6037.9	6037.9	0.0	99.46
28.7	177.2	2.673	0.167	1.38	2.55	0.281	5961.7	5961.7	0.0	99.46
29.5	177.4	2.385	0.300	1.50	4.41	0.328	5811.9	5811.9	0.0	99.46
30.8	177.9	2.318	0.446	1.66	7.63	0.350	5585.8	5585.8	0.0	99.46
34.3	179.4	4.375	0.630	2.00	16.04	0.584	6269.8	4580.1	0.0	96.37
34.9	179.7	4.637	0.650	2.09	16.12	0.599	6042.0	4352.6	0.0	96.26
35.9	180.1	4.473	0.675	2.21	16.12	0.598	5908.4	4219.1	0.0	96.18
38.6	181.7	4.148	0.708	2.51	16.12	0.596	5651.4	3962.0	0.0	96.03
44.0	185.2	3.795	0.731	3.00	16.12	0.587	5238.0	3548.4	0.0	95.76
50.2	189.7	3.538	0.740	3.50	16.12	0.578	4858.9	3169.2	0.0	95.47
57.0	194.9	3.329	0.744	4.00	16.12	0.569	4518.3	2828.4	0.0	95.17
64.9	200.9	3.136	0.747	4.54	16.12	0.559	4189.2	2499.1	0.0	94.84
72.0	206.1	2.989	0.748	5.00	16.12	0.551	3936.9	2246.8	0.0	94.54
78.9	210.9	2.135	0.739	5.42	16.12	0.424	1690.7	0.0	0.0	88.00
80.9	212.1	2.124	0.740	5.51	16.12	0.424	1690.7	0.0	0.0	88.00
91.7	219.4	2.074	0.742	6.00	16.12	0.427	1690.7	0.0	0.0	88.00
103.9	228.6	2.018	0.744	6.54	16.12	0.430	1690.7	0.0	0.0	88.00
114.9	236.9	1.967	0.747	7.00	16.12	0.432	1690.7	0.0	0.0	88.00
127.9	245.5	1.909	0.750	7.53	16.12	0.436	1690.7	0.0	0.0	88.00
140.1	252.4	1.856	0.753	8.00	16.12	0.440	1690.7	0.0	0.0	88.00
153.9	259.1	1.797	0.757	8.52	16.12	0.444	1690.7	0.0	0.0	88.00
167.5	264.8	1.741	0.760	9.00	16.12	0.448	1690.7	0.0	0.0	88.00
183.9	270.6	1.675	0.764	9.56	16.12	0.454	1690.7	0.0	0.0	88.00
197.7	274.8	1.622	0.767	10.00	16.12	0.460	1690.7	0.0	0.0	88.00

B/B-UFSAR

TABLE 6.2-31

DOUBLE-ENDED PUMP SUCTION BREAK MAXIMUM SAFEGUARDS POST-REFLOOD
MASS AND ENERGY RELEASES - UNIT 1

Time (sec)	Break Path No. 1*		Break Path No. 2**	
	Flow (lbm/sec)	Energy (1000 BTU/sec)	Flow (lbm/sec)	Energy (1000 BTU/sec)
197.8	166.5	209.5	1524.4	257.5
202.8	165.9	208.8	1525.0	257.4
207.8	165.4	208.2	1525.5	257.3
212.8	164.9	207.6	1525.9	257.3
217.8	165.9	208.8	1525.0	256.8
222.8	165.4	208.2	1525.5	256.7
227.8	164.9	207.5	1525.9	256.7
232.8	165.8	208.7	1525.0	256.2
237.8	165.3	208.1	1525.5	256.1
242.8	164.8	207.5	1526.0	256.0
247.8	165.8	208.7	1525.1	255.6
252.8	165.3	208.0	1525.6	255.5
257.8	164.8	207.4	1526.1	255.4
262.8	164.2	206.7	1526.6	255.4
267.8	165.2	207.9	1525.7	254.9
272.8	164.6	207.2	1526.2	254.9
277.8	164.1	206.6	1526.7	254.8
282.8	165.0	207.7	1525.8	254.3
287.8	164.5	207.0	1526.4	254.3
292.8	163.9	206.3	1526.9	254.2
297.8	164.8	207.4	1526.0	253.8
302.8	164.3	206.8	1526.6	253.7
307.8	163.7	206.1	1527.1	253.6
312.8	164.6	207.1	1526.3	253.2
317.8	164.0	206.4	1526.8	253.1
322.8	163.5	205.7	1527.4	253.0
327.8	164.3	206.8	1526.6	252.6
332.8	163.7	206.1	1527.1	252.6
337.8	164.5	207.1	1526.3	252.1
342.8	163.9	206.3	1526.9	252.1
347.8	163.4	205.6	1527.5	252.0
352.8	164.1	206.6	1526.7	251.6
357.8	163.5	205.9	1527.3	251.5
362.8	163.0	205.1	1527.9	251.5
367.8	163.7	206.0	1527.1	251.0
372.8	163.1	205.3	1527.7	251.0
377.8	163.8	206.2	1527.0	250.6
382.8	163.2	205.4	1527.6	250.5
387.8	162.6	204.7	1528.2	250.5
392.8	163.3	205.5	1527.5	250.1
397.8	162.7	204.7	1528.2	250.0
402.8	163.4	205.7	1527.4	249.6
407.8	162.9	205.1	1527.9	249.5
412.8	162.5	204.5	1528.4	249.4

TABLE 6.2-31 (Cont'd)

DOUBLE-ENDED PUMP SUCTION BREAK MAXIMUM SAFEGUARDS POST-REFLOOD
MASS AND ENERGY RELEASES - UNIT 1

Time (sec)	Break Path No. 1*		Break Path No. 2**	
	Flow (lbm/sec)	Energy (1000 BTU/sec)	Flow (lbm/sec)	Energy (1000 BTU/sec)
417.8	163.2	205.5	1527.6	249.0
422.8	162.7	204.8	1528.1	248.9
427.8	162.2	204.2	1528.6	248.8
432.8	163.0	205.2	1527.8	248.4
437.8	162.5	204.5	1528.4	248.3
442.8	163.2	205.4	1527.6	247.9
447.8	162.7	204.8	1528.2	247.9
452.8	162.2	204.1	1528.7	247.8
457.8	162.8	205.0	1528.0	247.4
462.8	162.3	204.3	1528.5	247.3
467.8	163.0	205.1	1527.9	253.7
472.8	162.4	204.4	1528.4	253.7
477.8	161.8	203.7	1529.0	253.6
482.8	162.5	204.5	1528.4	253.2
487.8	161.9	203.7	1529.0	253.1
492.8	162.5	204.5	1528.4	252.7
497.8	161.9	203.7	1529.0	252.6
502.8	162.4	204.4	1528.4	252.2
507.8	161.8	203.6	1529.1	252.1
512.8	162.3	204.3	1528.5	251.8
517.8	161.7	203.5	1529.2	251.7
522.8	162.1	204.1	1528.7	251.3
527.8	161.5	203.3	1529.4	251.2
532.8	161.9	203.8	1528.9	250.9
537.8	162.3	204.3	1528.5	250.5
542.8	161.6	203.5	1529.2	250.5
547.8	162.0	203.9	1528.8	250.1
552.8	161.3	203.0	1529.5	250.1
557.8	161.6	203.4	1529.2	249.7
562.8	161.9	203.8	1528.9	249.4
567.8	161.2	202.8	1529.7	249.4
572.8	161.4	203.2	1529.4	249.0
577.8	161.6	203.5	1529.2	248.7
582.8	161.8	203.7	1529.0	248.4
587.8	161.0	202.6	1529.9	248.4
592.8	161.1	202.8	1529.7	248.1
597.8	161.2	202.9	1529.6	247.8
602.8	161.3	203.1	1529.5	247.5
607.8	161.4	203.2	1529.4	247.3
612.8	161.5	203.2	1529.4	247.0
617.8	161.5	203.2	1529.4	246.8
622.8	161.4	203.2	1529.4	246.5
627.8	161.3	203.1	1529.5	246.3
632.8	161.2	202.9	1529.6	246.1

TABLE 6.2-31 (Cont'd)

DOUBLE-ENDED PUMP SUCTION BREAK MAXIMUM SAFEGUARDS POST-REFLOOD
MASS AND ENERGY RELEASES - UNIT 1

Time (sec)	Break Path No. 1*		Break Path No. 2**	
	Flow (lbm/sec)	Energy (1000 BTU/sec)	Flow (lbm/sec)	Energy (1000 BTU/sec)
637.8	161.0	202.7	1529.8	245.9
642.8	160.8	202.4	1530.1	245.7
647.8	160.5	202.0	1530.4	245.5
652.8	161.0	202.7	1529.8	245.1
657.8	160.6	202.1	1530.3	245.0
662.8	160.9	202.6	1529.9	244.6
667.8	160.3	201.8	1530.5	244.5
672.8	160.5	202.0	1530.3	244.2
677.8	160.5	202.0	1530.3	243.9
682.8	160.4	201.9	1530.4	243.7
687.8	160.9	202.6	1529.9	243.3
687.8	160.9	202.6	1529.9	243.3
692.8	160.5	202.0	1530.3	243.2
695.0	156.7	197.2	1451.6	339.7
700.0	156.9	197.5	1451.3	339.4
705.0	156.9	197.5	1451.3	339.1
710.0	156.7	197.2	1451.6	338.9
715.0	87.0	109.5	1521.3	357.3
946.9	87.0	109.5	1521.3	357.3
947.0	91.9	114.5	1516.3	354.5
950.0	91.8	114.5	1516.4	354.3
1512.8	91.8	114.5	1516.4	354.3
1512.9	81.6	93.9	1526.6	251.8
1600.0	80.6	92.8	1527.6	252.0
1600.1	80.6	92.8	1527.6	271.3
3600.0	65.9	75.9	1542.3	273.9
3600.1	54.4	62.6	1553.8	254.8
7000.0	44.0	50.6	1564.2	256.5
7000.1	42.7	49.1	1565.5	209.8
10000.0	38.4	44.2	1569.8	210.4
10000.1	37.8	43.4	1570.5	182.2
100000.0	20.2	23.2	1588.1	184.2
100000.1	20.0	23.0	1588.2	171.5
1000000.0	8.6	9.9	1599.7	172.8
1000000.1	8.6	9.9	1599.7	169.6
10000000.0	2.7	3.1	1605.6	170.2
0				

* mass and energy exiting the SG side of the break
 ** mass and energy exiting the pump side of the break

B/B-UFSAR

TABLE 6.2-32

DOUBLE-ENDED PUMP SUCTION BREAK MASS BALANCE MAXIMUM
SAFGUARDS - UNIT 1

Time (sec)		0.00	26.80	26.80	197.71	947.04	1512.83	3600.00
		Mass (1000 lbm)						
Initial	In RCS and ACC	815.56	815.56	815.56	815.56	815.56	815.56	815.56
Added Mass	Pumped Injection	0.00	0.00	0.00	280.01	1526.04	2435.96	5792.64
	Total Added	0.00	0.00	0.00	280.01	1526.04	2435.96	5792.64
TOTAL AVAILABLE		815.56	815.56	815.56	1095.56	2341.60	3251.51	6608.20
Distribution	Reactor Coolant	567.41	56.14	84.14	148.82	148.82	148.82	148.82
	Accumulator	248.14	200.63	172.62	0.00	0.00	0.00	0.00
	Total Contents	815.56	256.76	256.76	148.82	148.82	148.82	148.82
Effluent	Break Flow	0.00	570.25	570.25	946.54	2192.58	3102.40	6459.09
	ECCS Spill	0.00	0.00	0.00	0.00	0.00	0.00	0.00
	Total Effluent	0.00	570.25	570.25	946.54	2192.58	3102.40	6459.09
TOTAL ACCOUNTABLE		815.56	827.01	827.01	1095.36	2341.39	3251.22	6607.90

B/B-UFSAR

TABLE 6.2-33

DOUBLE-ENDED PUMP SUCTION BREAK ENERGY BALANCE MAXIMUM
SAFEGUARDS - UNIT 1

Time (sec)		0.00	26.80	26.80	197.71	947.04	1512.83	3600.00
		<u>Energy (10⁶ BTU)</u>						
Initial Energy	In RCS, ACC SG	987.47	987.47	987.47	987.47	987.47	987.47	987.47
Added Energy	Pumped Injection	0.00	0.00	0.00	24.64	160.23	298.54	847.36
	Decay Heat From Secondary	0.00	8.75	8.75	29.96	96.96	138.47	263.69
		0.00	0.03	0.03	0.03	10.18	15.94	15.94
	Total Added	0.00	8.78	8.78	54.64	267.38	452.96	1126.99
TOTAL AVAILABLE		987.47	996.25	996.25	1042.11	1254.85	1440.43	2114.46
Distribution	Reactor Coolant Accumulator	341.36	12.17	14.95	38.95	38.95	38.95	38.95
	Core Stored	24.68	19.95	17.17	0.00	0.00	0.00	0.00
	Primary Metal	23.82	12.94	12.94	4.91	4.71	4.41	3.33
		169.14	160.64	160.64	132.46	91.34	75.39	57.86
	Secondary Metal	119.11	119.14	119.14	109.53	78.90	62.07	47.96
	Steam Generator	309.36	309.44	309.44	280.29	203.89	165.86	131.12
	Total Contents	987.47	634.28	634.28	566.14	417.79	346.69	279.23
	Effluent	Break Flow	0.00	362.39	362.39	466.97	828.06	1077.70
ECCS Spill		0.00	0.00	0.00	0.00	0.00	0.00	0.00
Total Effluent		0.00	362.39	362.39	466.97	828.06	1077.70	1821.64
TOTAL ACCOUNTABLE		987.47	996.67	996.67	1033.11	1245.85	1424.40	2100.88

TABLE 6.2-34

DOUBLE-ENDED HOT LEG BREAK BLOWDOWN MASS AND ENERGY
RELEASES - UNIT 2

TIME (SECONDS)	<u>BREAK PATH NO.1*</u>		<u>BREAK PATH NO.2**</u>	
	FLOW (LBM/SEC)	ENERGY (THOUSANDS BTU/SEC)	FLOW (LBM/SEC)	ENERGY (THOUSANDS BTU/SEC)
0.000000E+00	0.000000E+00	0.000000E+00	0.000000E+00	0.000000E+00
1.136575E-03	1.981247E+03	1.305075E+03	1.981198E+03	1.304096E+03
2.224618E-03	4.468274E+03	2.948947E+03	4.800761E+03	3.152808E+03
1.014002E-01	4.351383E+04	2.898148E+04	2.800175E+04	1.834941E+04
2.019356E-01	3.686354E+04	2.469200E+04	2.448619E+04	1.594440E+04
3.014987E-01	3.790979E+04	2.539363E+04	2.177780E+04	1.399031E+04
4.017139E-01	3.681159E+04	2.466941E+04	2.038777E+04	1.286381E+04
5.010221E-01	3.655878E+04	2.451512E+04	1.959035E+04	1.214195E+04
6.016651E-01	3.613983E+04	2.426314E+04	1.902986E+04	1.160592E+04
7.016532E-01	3.557857E+04	2.392667E+04	1.860857E+04	1.119457E+04
8.014509E-01	3.491345E+04	2.352989E+04	1.831373E+04	1.089216E+04
9.010227E-01	3.426357E+04	2.315175E+04	1.809461E+04	1.065981E+04
1.001410E+00	3.373148E+04	2.286061E+04	1.796462E+04	1.049839E+04
1.101958E+00	3.324598E+04	2.260572E+04	1.794517E+04	1.041475E+04
1.201662E+00	3.276568E+04	2.235712E+04	1.800208E+04	1.038547E+04
1.301410E+00	3.216462E+04	2.202584E+04	1.808822E+04	1.038114E+04
1.401458E+00	3.158273E+04	2.169162E+04	1.819666E+04	1.039668E+04
1.501222E+00	3.110553E+04	2.141686E+04	1.831118E+04	1.042293E+04
1.602034E+00	3.072685E+04	2.120232E+04	1.842991E+04	1.045794E+04
1.702200E+00	3.031890E+04	2.096365E+04	1.853087E+04	1.048959E+04
1.802145E+00	2.977598E+04	2.062400E+04	1.860378E+04	1.051131E+04
1.901832E+00	2.918045E+04	2.024063E+04	1.865092E+04	1.052365E+04
2.001117E+00	2.866387E+04	1.991077E+04	1.867727E+04	1.052853E+04
2.101911E+00	2.823694E+04	1.964609E+04	1.868578E+04	1.052667E+04
2.201838E+00	2.780038E+04	1.937235E+04	1.867338E+04	1.051589E+04
2.301580E+00	2.731567E+04	1.905819E+04	1.863839E+04	1.049470E+04
2.401670E+00	2.680234E+04	1.871718E+04	1.858593E+04	1.046541E+04
2.501399E+00	2.632296E+04	1.839556E+04	1.851920E+04	1.042941E+04
2.602117E+00	2.591022E+04	1.811956E+04	1.844251E+04	1.038877E+04
2.701565E+00	2.554003E+04	1.787145E+04	1.835987E+04	1.034539E+04

TABLE 6.2-34 (Cont'd)

DOUBLE-ENDED HOT LEG BREAK BLOWDOWN MASS AND ENERGY
RELEASES - UNIT 2

TIME (SECONDS)	<u>BREAK PATH NO.1*</u>		<u>BREAK PATH NO.2**</u>	
	FLOW (LBM/SEC)	ENERGY (THOUSANDS BTU/SEC)	FLOW (LBM/SEC)	ENERGY (THOUSANDS BTU/SEC)
2.801157E+00	2.514850E+04	1.760197E+04	1.826794E+04	1.029719E+04
2.901735E+00	2.475403E+04	1.732381E+04	1.816465E+04	1.024291E+04
3.001611E+00	2.438893E+04	1.706169E+04	1.805961E+04	1.018771E+04
3.101008E+00	2.404826E+04	1.681228E+04	1.795030E+04	1.013014E+04
3.201399E+00	2.375278E+04	1.659186E+04	1.783722E+04	1.007046E+04
3.302044E+00	2.347910E+04	1.638328E+04	1.772243E+04	1.000975E+04
3.401738E+00	2.320960E+04	1.617336E+04	1.760314E+04	9.946440E+03
3.501784E+00	2.297161E+04	1.598212E+04	1.748086E+04	9.881401E+03
3.601186E+00	2.274843E+04	1.579809E+04	1.735748E+04	9.815707E+03
3.701420E+00	2.254548E+04	1.562537E+04	1.722958E+04	9.747535E+03
3.801232E+00	2.237267E+04	1.547198E+04	1.710096E+04	9.678963E+03
3.901661E+00	2.220995E+04	1.532344E+04	1.696909E+04	9.608648E+03
4.001325E+00	2.207451E+04	1.519266E+04	1.683617E+04	9.537793E+03
4.200749E+00	2.192009E+04	1.500847E+04	1.656453E+04	9.393055E+03
4.400590E+00	2.184796E+04	1.488117E+04	1.628997E+04	9.247035E+03
4.600184E+00	2.177502E+04	1.476067E+04	1.601789E+04	9.102840E+03
4.800370E+00	2.174746E+04	1.467766E+04	1.576120E+04	8.968450E+03
5.001087E+00	2.172616E+04	1.460285E+04	1.554910E+04	8.860455E+03
5.200513E+00	2.170815E+04	1.453503E+04	1.525137E+04	8.702783E+03
5.400299E+00	2.171506E+04	1.448177E+04	1.497944E+04	8.562055E+03
5.601136E+00	2.180654E+04	1.447004E+04	1.469601E+04	8.416535E+03
5.800257E+00	2.192385E+04	1.446628E+04	1.437968E+04	8.252875E+03
6.000427E+00	2.208839E+04	1.448020E+04	1.407681E+04	8.098390E+03
6.200499E+00	2.234135E+04	1.453982E+04	1.379503E+04	7.955535E+03
6.400539E+00	2.280823E+04	1.470578E+04	1.347764E+04	7.790174E+03
6.600151E+00	1.658473E+04	1.169365E+04	1.315470E+04	7.621450E+03
6.800919E+00	1.727581E+04	1.205744E+04	1.289188E+04	7.487277E+03
7.000595E+00	1.736337E+04	1.201666E+04	1.262349E+04	7.348518E+03
7.200045E+00	1.751154E+04	1.202970E+04	1.236000E+04	7.210301E+03
7.400789E+00	1.765663E+04	1.202519E+04	1.209492E+04	7.069858E+03
7.600945E+00	1.763810E+04	1.196470E+04	1.184986E+04	6.940364E+03
7.800557E+00	1.768968E+04	1.191410E+04	1.161113E+04	6.813464E+03
8.000869E+00	1.776058E+04	1.191913E+04	1.137922E+04	6.689443E+03

TABLE 6.2-34 (Cont'd)

DOUBLE-ENDED HOT LEG BREAK BLOWDOWN MASS AND ENERGY
RELEASES - UNIT 2

TIME (SECONDS)	<u>BREAK PATH NO.1*</u>		<u>BREAK PATH NO.2**</u>	
	FLOW (LBM/SEC)	ENERGY (THOUSANDS BTU/SEC)	FLOW (LBM/SEC)	ENERGY (THOUSANDS BTU/SEC)
8.200314E+00	1.782812E+04	1.190272E+04	1.115033E+04	6.566145E+03
8.400928E+00	1.781597E+04	1.185614E+04	1.092885E+04	6.446899E+03
8.601108E+00	1.780065E+04	1.179064E+04	1.070857E+04	6.327932E+03
8.800071E+00	1.742931E+04	1.156095E+04	1.049023E+04	6.209876E+03
9.000849E+00	1.741590E+04	1.152856E+04	1.027428E+04	6.093391E+03
9.201312E+00	1.735558E+04	1.146520E+04	1.006040E+04	5.978074E+03
9.400411E+00	1.726416E+04	1.138395E+04	9.847780E+03	5.863331E+03
9.601070E+00	1.709785E+04	1.126341E+04	9.631602E+03	5.746675E+03
9.800646E+00	1.682111E+04	1.108720E+04	9.417702E+03	5.631607E+03
1.000070E+01	1.641476E+04	1.084622E+04	9.202444E+03	5.515885E+03
1.020134E+01	1.589493E+04	1.055002E+04	8.986705E+03	5.400113E+03
1.020282E+01	1.589081E+04	1.054768E+04	8.985114E+03	5.399257E+03
1.040108E+01	1.533982E+04	1.024066E+04	8.773579E+03	5.286009E+03
1.060143E+01	1.481072E+04	9.950614E+03	8.561705E+03	5.172825E+03
1.080092E+01	1.431466E+04	9.681632E+03	8.352983E+03	5.061674E+03
1.100129E+01	1.383743E+04	9.424611E+03	8.143961E+03	4.950276E+03
1.120129E+01	1.336849E+04	9.171663E+03	7.935666E+03	4.839950E+03
1.140167E+01	1.290998E+04	8.922824E+03	7.725793E+03	4.728265E+03
1.160014E+01	1.246641E+04	8.679958E+03	7.508706E+03	4.612651E+03
1.180063E+01	1.203542E+04	8.441986E+03	7.280929E+03	4.491624E+03
1.200165E+01	1.162020E+04	8.212654E+03	7.048429E+03	4.369571E+03
1.220003E+01	1.122287E+04	7.993984E+03	6.814671E+03	4.247363E+03
1.240036E+01	1.083003E+04	7.781464E+03	6.585035E+03	4.128597E+03
1.260159E+01	1.044002E+04	7.575538E+03	6.358148E+03	4.011485E+03
1.280137E+01	1.005314E+04	7.376810E+03	6.138725E+03	3.898297E+03
1.300203E+01	9.634890E+03	7.186344E+03	5.918111E+03	3.784131E+03
1.320017E+01	8.720250E+03	6.918940E+03	5.685709E+03	3.663154E+03
1.340128E+01	7.996609E+03	6.685194E+03	5.421308E+03	3.526374E+03
1.360129E+01	7.340100E+03	6.403749E+03	5.120163E+03	3.370054E+03
1.380051E+01	6.704333E+03	6.076763E+03	4.793216E+03	3.199846E+03
1.400142E+01	6.070176E+03	5.727020E+03	4.451533E+03	3.020683E+03
1.420155E+01	5.528637E+03	5.389884E+03	4.116769E+03	2.846202E+03
1.440064E+01	5.113396E+03	5.072411E+03	3.800365E+03	2.682092E+03

TABLE 6.2-34 (Cont'd)

DOUBLE-ENDED HOT LEG BREAK BLOWDOWN MASS AND ENERGY
RELEASES - UNIT 2

TIME (SECONDS)	<u>BREAK PATH NO.1*</u>		<u>BREAK PATH NO.2**</u>	
	FLOW (LBM/SEC)	ENERGY (THOUSANDS BTU/SEC)	FLOW (LBM/SEC)	ENERGY (THOUSANDS BTU/SEC)
1.460076E+01	4.740946E+03	4.788439E+03	3.509097E+03	2.529534E+03
1.480075E+01	4.390978E+03	4.539931E+03	3.242890E+03	2.390239E+03
1.500068E+01	4.081782E+03	4.319358E+03	2.999233E+03	2.265632E+03
1.520079E+01	3.803648E+03	4.112601E+03	2.777892E+03	2.154171E+03
1.540014E+01	3.559418E+03	3.914318E+03	2.576365E+03	2.054332E+03
1.560057E+01	3.334802E+03	3.729398E+03	2.397790E+03	1.964616E+03
1.580080E+01	3.101744E+03	3.528954E+03	2.239556E+03	1.886458E+03
1.600051E+01	2.896200E+03	3.349945E+03	2.101009E+03	1.818266E+03
1.620041E+01	2.691367E+03	3.174662E+03	1.991052E+03	1.761018E+03
1.640065E+01	2.507346E+03	3.028362E+03	1.894811E+03	1.706635E+03
1.660049E+01	2.302950E+03	2.830062E+03	1.801833E+03	1.657401E+03
1.680037E+01	2.144371E+03	2.655460E+03	1.706093E+03	1.614387E+03
1.700015E+01	2.000759E+03	2.487793E+03	1.606673E+03	1.571639E+03
1.720030E+01	1.891219E+03	2.357135E+03	1.504036E+03	1.531573E+03
1.740031E+01	1.826193E+03	2.267233E+03	1.395988E+03	1.488295E+03
1.760015E+01	1.757867E+03	2.178268E+03	1.295741E+03	1.444433E+03
1.780073E+01	1.691471E+03	2.093168E+03	1.209760E+03	1.390784E+03
1.800034E+01	1.621530E+03	2.008154E+03	1.142311E+03	1.344113E+03
1.820099E+01	1.548606E+03	1.920204E+03	1.151291E+03	1.371293E+03
1.840076E+01	1.494461E+03	1.849901E+03	1.086093E+03	1.298692E+03
1.860066E+01	1.443674E+03	1.783094E+03	1.038916E+03	1.252042E+03
1.880073E+01	1.400052E+03	1.729042E+03	9.400072E+02	1.149631E+03
1.900016E+01	1.339175E+03	1.661928E+03	8.058861E+02	9.943219E+02
1.920063E+01	1.137547E+03	1.438864E+03	7.312755E+02	9.053598E+02
1.940052E+01	9.771373E+02	1.239616E+03	6.814092E+02	8.441418E+02
1.960006E+01	8.280051E+02	1.050943E+03	6.367283E+02	7.902548E+02
1.980047E+01	6.826189E+02	8.670762E+02	5.250805E+02	6.516650E+02
2.000001E+01	6.134937E+02	7.779753E+02	4.643149E+02	5.790040E+02
2.020014E+01	5.009611E+02	6.323161E+02	3.751393E+02	4.677005E+02
2.040067E+01	3.503304E+02	4.412629E+02	3.475900E+02	4.348189E+02
2.060099E+01	2.210329E+02	2.784827E+02	3.013509E+02	3.773814E+02
2.080018E+01	1.191013E+02	1.498856E+02	2.494284E+02	3.130316E+02
2.100059E+01	4.133309E+01	5.220214E+01	1.559792E+02	1.964134E+02

TABLE 6.2-34 (Cont'd)

DOUBLE-ENDED HOT LEG BREAK BLOWDOWN MASS AND ENERGY
RELEASES - UNIT 2

TIME (SECONDS)	<u>BREAK PATH NO.1*</u>		<u>BREAK PATH NO.2**</u>	
	FLOW (LBM/SEC)	ENERGY (THOUSANDS BTU/SEC)	FLOW (LBM/SEC)	ENERGY (THOUSANDS BTU/SEC)
2.120004E+01	0.000000E+00	0.000000E+00	8.962929E+01	1.137990E+02
2.140050E+01	0.000000E+00	0.000000E+00	8.476988E+01	1.081520E+02
2.160085E+01	0.000000E+00	0.000000E+00	8.794784E+01	1.124021E+02
2.180066E+01	0.000000E+00	0.000000E+00	8.279589E+01	1.059379E+02
2.200026E+01	0.000000E+00	0.000000E+00	7.441969E+01	9.535506E+01
2.220116E+01	0.000000E+00	0.000000E+00	1.042437E+02	1.339898E+02
2.240110E+01	0.000000E+00	0.000000E+00	0.000000E+00	0.000000E+00

* mass and energy exiting from the reactor vessel side of the break

** mass and energy exiting from the SG side of the break

TABLE 6.2-35

DOUBLE-ENDED HOT LEG BREAK MASS BALANCE - UNIT 2

TIME (SECONDS)		0.00	22.40	22.40
		MASS (THOUSAND LBM)		
Initial	RCS and ACC	760.28	760.28	760.28
Added Mass	Pumped Injection	0.00	0.00	0.00
	Total Added	0.00	0.00	0.00
TOTAL AVAILABLE		760.28	760.28	760.28
Distribution	Reactor Coolant	511.41	80.02	117.44
	Accumulator	248.87	193.82	156.40
	Total Contents	760.28	273.84	273.84
Effluent	Break Flow	0.00	486.45	486.45
	ECCS Spill	0.00	0.00	0.00
	Total Effluent	0.00	486.45	486.45
TOTAL ACCOUNTABLE		760.28	760.28	760.28

TABLE 6.2-36

DOUBLE-ENDED HOT LEG BREAK ENERGY BALANCE - UNIT 2

TIME (SECONDS)		0.00	22.40	22.40
		ENERGY (MILLION BTU)		
Initial Energy In RCS, ACC, S GEN		835.42	835.42	835.42
Added Energy	Pumped Injection	0.00	0.00	0.00
	Decay Heat	0.00	8.02	8.02
	Heat From Secondary	0.00	-0.32	-0.32
	Total Added	0.00	7.70	7.70
TOTAL AVAILABLE		835.42	843.12	843.12
Distribution	Reactor Coolant	309.15	21.25	24.97
	Accumulator	22.27	17.35	13.62
	Core Stored	23.01	9.14	9.14
	Primary Metal	160.32	150.87	150.87
	Secondary Metal	73.35	73.03	73.03
	Steam Generator	247.33	245.96	245.96
	Total Contents	835.42	517.60	517.60
Effluent	Break Flow	0.00	324.95	324.95
	ECCS Spill	0.00	0.00	0.00
	Total Effluent	0.00	324.95	324.95
TOTAL ACCOUNTABLE		835.42	842.55	842.55

TABLE 6.2-37

DOUBLE-ENDED PUMP SUCTION BREAK MINIMUM SAFEGUARDS BLOWDOWN
MASS AND ENERGY RELEASES - UNIT 2

TIME (SECONDS)	<u>BREAK PATH NO. 1*</u>		<u>BREAK PATH NO. 2**</u>	
	FLOW (LBM/SEC)	ENERGY (THOUSANDS BTU/SEC)	FLOW (LBM/SEC)	ENERGY (THOUSANDS BTU/SEC)
0.000000E+00	0.000000E+00	0.000000E+00	0.000000E+00	0.000000E+00
1.016345E-03	3.904093E+03	2.205378E+03	3.806571E+03	2.148614E+03
2.091869E-03	8.289914E+03	4.684635E+03	6.078713E+03	3.406687E+03
1.010008E-01	3.869344E+04	2.174150E+04	1.951426E+04	1.094470E+04
2.014941E-01	4.524526E+04	2.561185E+04	2.471142E+04	1.384306E+04
3.016118E-01	4.686084E+04	2.681227E+04	2.518752E+04	1.412309E+04
4.011108E-01	4.716434E+04	2.735598E+04	2.459138E+04	1.380505E+04
5.019734E-01	4.273358E+04	2.515322E+04	2.363923E+04	1.328248E+04
6.013436E-01	4.284363E+04	2.554843E+04	2.281761E+04	1.282768E+04
7.012544E-01	4.301337E+04	2.594627E+04	2.207817E+04	1.241523E+04
8.016164E-01	4.266267E+04	2.599865E+04	2.145598E+04	1.206782E+04
9.020751E-01	4.199850E+04	2.583049E+04	2.098059E+04	1.180286E+04
1.002137E+00	4.123189E+04	2.557017E+04	2.068215E+04	1.163608E+04
1.101827E+00	4.042820E+04	2.526310E+04	2.046810E+04	1.151757E+04
1.201416E+00	3.963727E+04	2.495107E+04	2.036776E+04	1.146184E+04
1.301123E+00	3.891044E+04	2.467749E+04	2.029158E+04	1.141947E+04
1.401537E+00	3.821451E+04	2.442918E+04	2.022765E+04	1.138323E+04
1.501693E+00	3.710394E+04	2.392045E+04	2.018141E+04	1.135663E+04
1.602096E+00	3.606040E+04	2.345467E+04	2.016490E+04	1.134678E+04
1.702120E+00	3.505929E+04	2.301051E+04	2.015892E+04	1.134298E+04
1.802120E+00	3.401428E+04	2.252441E+04	2.013375E+04	1.132826E+04
1.902161E+00	3.303324E+04	2.205962E+04	2.006809E+04	1.129047E+04
2.001321E+00	3.207823E+04	2.158805E+04	1.997001E+04	1.123460E+04
2.102446E+00	3.116064E+04	2.112400E+04	1.985937E+04	1.117212E+04
2.202084E+00	3.029624E+04	2.067545E+04	1.971557E+04	1.109121E+04
2.301545E+00	2.942584E+04	2.020788E+04	1.936735E+04	1.089413E+04
2.401315E+00	2.854347E+04	1.972281E+04	1.901177E+04	1.069474E+04
2.501179E+00	2.764774E+04	1.921838E+04	1.881051E+04	1.058282E+04
2.601072E+00	2.661978E+04	1.861108E+04	1.860719E+04	1.046966E+04
2.701008E+00	2.565794E+04	1.804807E+04	1.838015E+04	1.034322E+04
2.801017E+00	2.464413E+04	1.744265E+04	1.812284E+04	1.019990E+04
2.901324E+00	2.369644E+04	1.687602E+04	1.781703E+04	1.002946E+04

TABLE 6.2-37 (Cont'd)

DOUBLE-ENDED PUMP SUCTION BREAK MINIMUM SAFEGUARDS BLOWDOWN
MASS AND ENERGY RELEASES - UNIT 2

TIME (SECONDS)	<u>BREAK PATH NO. 1*</u>		<u>BREAK PATH NO. 2**</u>	
	FLOW (LBM/SEC)	ENERGY (THOUSANDS BTU/SEC)	FLOW (LBM/SEC)	ENERGY (THOUSANDS BTU/SEC)
3.001056E+00	2.285517E+04	1.636973E+04	1.758172E+04	9.899453E+03
3.101467E+00	2.209172E+04	1.590282E+04	1.736500E+04	9.780110E+03
3.201379E+00	2.140031E+04	1.547085E+04	1.713297E+04	9.652038E+03
3.301171E+00	2.076904E+04	1.506890E+04	1.690592E+04	9.526959E+03
3.401422E+00	2.020028E+04	1.469855E+04	1.669309E+04	9.410137E+03
3.501146E+00	1.969527E+04	1.436130E+04	1.648139E+04	9.294017E+03
3.601178E+00	1.922739E+04	1.404100E+04	1.628422E+04	9.186223E+03
3.701104E+00	1.869944E+04	1.366883E+04	1.609866E+04	9.085106E+03
3.801046E+00	1.819354E+04	1.330888E+04	1.590772E+04	8.980876E+03
3.901126E+00	1.782484E+04	1.304421E+04	1.573589E+04	8.887628E+03
4.001061E+00	1.752839E+04	1.282327E+04	1.556114E+04	8.792991E+03
4.200123E+00	1.703240E+04	1.243812E+04	1.526606E+04	8.633710E+03
4.400151E+00	1.668354E+04	1.214639E+04	1.498048E+04	8.480168E+03
4.600047E+00	1.645115E+04	1.192995E+04	1.472672E+04	8.344734E+03
4.800454E+00	1.634101E+04	1.179331E+04	1.493471E+04	8.479224E+03
5.000218E+00	1.628415E+04	1.169048E+04	1.571297E+04	8.924160E+03
5.200524E+00	1.625502E+04	1.160570E+04	1.562476E+04	8.884426E+03
5.400353E+00	1.625867E+04	1.154480E+04	1.548839E+04	8.816026E+03
5.600320E+00	1.628362E+04	1.150202E+04	1.536552E+04	8.754627E+03
5.800413E+00	1.630190E+04	1.146064E+04	1.518299E+04	8.658689E+03
6.000011E+00	1.631215E+04	1.142216E+04	1.497807E+04	8.549088E+03
6.200363E+00	1.630474E+04	1.138109E+04	1.478789E+04	8.446675E+03
6.400321E+00	1.627741E+04	1.133640E+04	1.464482E+04	8.369773E+03
6.600273E+00	1.623614E+04	1.128130E+04	1.455979E+04	8.324057E+03
6.800162E+00	1.621040E+04	1.123038E+04	1.439407E+04	8.228779E+03
7.000060E+00	1.621814E+04	1.119298E+04	1.421312E+04	8.123886E+03
7.200402E+00	1.628070E+04	1.117692E+04	1.406901E+04	8.041868E+03
7.400020E+00	1.689960E+04	1.168373E+04	1.395797E+04	7.978731E+03
7.600025E+00	1.458654E+04	1.081183E+04	1.382293E+04	7.900451E+03
7.800348E+00	1.458252E+04	1.075087E+04	1.351796E+04	7.723966E+03
8.000025E+00	1.480847E+04	1.077864E+04	1.340663E+04	7.664085E+03
8.200102E+00	1.502981E+04	1.081205E+04	1.325016E+04	7.576909E+03
8.400454E+00	1.520484E+04	1.081892E+04	1.300950E+04	7.436727E+03
8.600049E+00	1.534409E+04	1.081821E+04	1.282980E+04	7.333584E+03
8.800213E+00	1.542426E+04	1.079282E+04	1.268751E+04	7.253339E+03
9.000255E+00	1.548355E+04	1.076451E+04	1.246505E+04	7.124517E+03
9.200570E+00	1.548915E+04	1.071449E+04	1.228490E+04	7.020829E+03
9.400162E+00	1.542960E+04	1.063417E+04	1.211918E+04	6.926094E+03
9.600081E+00	1.533191E+04	1.054220E+04	1.191250E+04	6.806553E+03
9.800532E+00	1.513181E+04	1.040470E+04	1.174446E+04	6.709577E+03
1.000041E+01	1.485799E+04	1.023596E+04	1.154981E+04	6.597141E+03

TABLE 6.2-37 (Cont'd)

DOUBLE-ENDED PUMP SUCTION BREAK MINIMUM SAFEGUARDS BLOWDOWN
MASS AND ENERGY RELEASES - UNIT 2

TIME (SECONDS)	<u>BREAK PATH NO. 1*</u>		<u>BREAK PATH NO. 2**</u>	
	FLOW (LBM/SEC)	ENERGY (THOUSANDS BTU/SEC)	FLOW (LBM/SEC)	ENERGY (THOUSANDS BTU/SEC)
1.020034E+01	1.452033E+04	1.003272E+04	1.136869E+04	6.492174E+03
1.040014E+01	1.411849E+04	9.797121E+03	1.118048E+04	6.382768E+03
1.060057E+01	1.373503E+04	9.601892E+03	1.102083E+04	6.289549E+03
1.080054E+01	1.306522E+04	9.222574E+03	1.081876E+04	6.170727E+03
1.100009E+01	1.231974E+04	8.785554E+03	1.067419E+04	6.085560E+03
1.120025E+01	1.156976E+04	8.326148E+03	1.049594E+04	5.979507E+03
1.140008E+01	1.085369E+04	7.884932E+03	1.035674E+04	5.895143E+03
1.160048E+01	1.015185E+04	7.458110E+03	1.020039E+04	5.799853E+03
1.180015E+01	9.466629E+03	7.049620E+03	1.008473E+04	5.726874E+03
1.200053E+01	8.847533E+03	6.694451E+03	9.945645E+03	5.638694E+03
1.200311E+01	8.840035E+03	6.690219E+03	9.943702E+03	5.637458E+03
1.200441E+01	8.836288E+03	6.688096E+03	9.942744E+03	5.636871E+03
1.200570E+01	8.832543E+03	6.685976E+03	9.941791E+03	5.636250E+03
1.200699E+01	8.828801E+03	6.683859E+03	9.940836E+03	5.635662E+03
1.200828E+01	8.825064E+03	6.681758E+03	9.939879E+03	5.635070E+03
1.200957E+01	8.821336E+03	6.679671E+03	9.938917E+03	5.634471E+03
1.201087E+01	8.817617E+03	6.677585E+03	9.937948E+03	5.633869E+03
1.201216E+01	8.813906E+03	6.675509E+03	9.936982E+03	5.633233E+03
1.201345E+01	8.810202E+03	6.673436E+03	9.936027E+03	5.632633E+03
1.201475E+01	8.806505E+03	6.671370E+03	9.935090E+03	5.632045E+03
1.220030E+01	8.308209E+03	6.396940E+03	9.852425E+03	5.575845E+03
1.240059E+01	7.850190E+03	6.152340E+03	9.714182E+03	5.485754E+03
1.260029E+01	7.462000E+03	5.946670E+03	9.633425E+03	5.428058E+03
1.280060E+01	7.123794E+03	5.766133E+03	9.492501E+03	5.335091E+03
1.300116E+01	6.822408E+03	5.605364E+03	9.419646E+03	5.280932E+03
1.320039E+01	6.533436E+03	5.449108E+03	9.282989E+03	5.186710E+03
1.340085E+01	6.217352E+03	5.274930E+03	9.158267E+03	5.085248E+03
1.360099E+01	5.901628E+03	5.104562E+03	9.108960E+03	5.006424E+03
1.380072E+01	5.558713E+03	4.947121E+03	8.825934E+03	4.796236E+03
1.400059E+01	5.037529E+03	4.780529E+03	8.915465E+03	4.767689E+03
1.420042E+01	4.432622E+03	4.582094E+03	8.438872E+03	4.422881E+03
1.440087E+01	3.953861E+03	4.434255E+03	8.103409E+03	4.136271E+03
1.460019E+01	3.569657E+03	4.268497E+03	1.158231E+04	5.864572E+03
1.480056E+01	3.101041E+03	3.821612E+03	1.115076E+04	5.634225E+03
1.500126E+01	2.752629E+03	3.420480E+03	1.070683E+04	5.364514E+03
1.520016E+01	2.640325E+03	3.291666E+03	4.422998E+03	2.173265E+03
1.540042E+01	2.436692E+03	3.045498E+03	6.975108E+03	3.187862E+03
1.560014E+01	2.285450E+03	2.866422E+03	6.860279E+03	3.163896E+03
1.580018E+01	2.168459E+03	2.723590E+03	4.564157E+03	2.070876E+03
1.600027E+01	2.014340E+03	2.532936E+03	6.495048E+03	2.697934E+03
1.620016E+01	1.837935E+03	2.315829E+03	7.700385E+03	3.199648E+03
1.640033E+01	1.682145E+03	2.123653E+03	6.872908E+03	2.874827E+03

TABLE 6.2-37 (Cont'd)

DOUBLE-ENDED PUMP SUCTION BREAK MINIMUM SAFEGUARDS BLOWDOWN
MASS AND ENERGY RELEASES - UNIT 2

TIME (SECONDS)	<u>BREAK PATH NO. 1*</u>		<u>BREAK PATH NO. 2**</u>	
	FLOW (LBM/SEC)	ENERGY (THOUSANDS BTU/SEC)	FLOW (LBM/SEC)	ENERGY (THOUSANDS BTU/SEC)
1.660028E+01	1.543602E+03	1.952071E+03	7.452380E+03	3.098392E+03
1.680028E+01	1.415047E+03	1.792993E+03	6.942152E+03	2.859416E+03
1.700007E+01	1.336320E+03	1.695877E+03	4.499799E+03	1.830826E+03
1.720020E+01	1.274353E+03	1.618731E+03	3.034105E+03	1.239720E+03
1.740054E+01	1.187384E+03	1.508968E+03	2.351121E+03	9.146679E+02
1.760090E+01	1.097241E+03	1.396092E+03	5.107788E+03	1.738119E+03
1.780008E+01	1.019958E+03	1.299048E+03	4.682171E+03	1.581929E+03
1.800068E+01	9.430719E+02	1.202203E+03	4.432051E+03	1.500909E+03
1.820006E+01	9.009129E+02	1.150557E+03	4.678806E+03	1.577117E+03
1.840027E+01	8.201484E+02	1.048509E+03	4.722233E+03	1.569608E+03
1.860020E+01	7.470939E+02	9.556610E+02	3.860038E+03	1.265308E+03
1.880056E+01	6.819645E+02	8.728276E+02	3.579113E+03	1.155314E+03
1.900067E+01	6.275970E+02	8.036810E+02	3.428468E+03	1.087979E+03
1.920055E+01	5.864545E+02	7.512477E+02	3.292579E+03	1.024493E+03
1.940068E+01	5.532716E+02	7.091297E+02	3.103308E+03	9.445544E+02
1.960004E+01	5.251365E+02	6.733052E+02	2.899324E+03	8.605913E+02
1.980043E+01	4.923592E+02	6.314883E+02	2.632363E+03	7.605215E+02
2.000072E+01	4.599742E+02	5.901560E+02	2.271587E+03	6.391389E+02
2.020012E+01	4.296475E+02	5.514384E+02	1.799161E+03	4.945158E+02
2.040054E+01	3.996275E+02	5.130652E+02	1.202182E+03	3.246862E+02
2.060071E+01	3.688615E+02	4.737157E+02	4.905204E+02	1.315089E+02
2.080032E+01	3.383638E+02	4.346942E+02	2.484009E+01	6.874184E+00
2.100029E+01	3.075986E+02	3.953010E+02	4.518594E+00	1.895438E+00
2.120057E+01	2.768292E+02	3.558878E+02	7.510284E+00	7.248856E+00
2.140013E+01	2.466269E+02	3.171787E+02	1.649561E+01	1.787495E+01
2.160003E+01	2.152839E+02	2.769835E+02	4.390336E+00	5.073915E+00
2.180029E+01	1.683923E+02	2.167625E+02	7.183017E+00	8.689577E+00
2.200011E+01	1.086198E+02	1.400050E+02	5.844815E+00	7.221996E+00
2.220001E+01	0.000000E+00	0.000000E+00	0.000000E+00	0.000000E+00

* mass and energy exiting the SG side of the break

** mass and energy exiting the pump side of the break

TABLE 6.2-38

DOUBLE-ENDED PUMP SUCTION BREAK MINIMUM SAFEGUARDS REFLOOD
MASS AND ENERGY RELEASES - UNIT 2

TIME (SECONDS)	<u>BREAK PATH NO. 1*</u>		<u>BREAK PATH NO. 2**</u>	
	FLOW (LBM/SEC)	ENERGY (THOUSANDS BTU/SEC)	FLOW (LBM/SEC)	ENERGY (THOUSANDS BTU/SEC)
2.277E+01	4.590E-04	5.394E-04	1.377E-04	1.326E-05
2.287E+01	4.590E-04	5.394E-04	1.377E-04	1.326E-05
2.307E+01	4.590E-04	5.394E-04	1.377E-04	1.326E-05
2.317E+01	4.590E-04	5.394E-04	1.377E-04	1.321E-05
2.327E+01	4.591E-04	5.395E-04	1.377E-04	1.321E-05
2.337E+01	6.529E+01	7.675E+01	1.377E-04	1.542E-05
2.348E+01	2.150E+01	2.526E+01	1.377E-04	1.386E-05
2.358E+01	1.325E+01	1.557E+01	1.377E-04	1.360E-05
2.368E+01	1.556E+01	1.829E+01	1.377E-04	1.372E-05
2.378E+01	2.210E+01	2.597E+01	1.377E-04	1.401E-05
2.388E+01	2.968E+01	3.488E+01	1.377E-04	1.419E-05
2.398E+01	3.595E+01	4.226E+01	1.377E-04	1.438E-05
2.408E+01	4.005E+01	4.707E+01	1.377E-04	1.451E-05
2.418E+01	4.416E+01	5.190E+01	1.377E-04	1.465E-05
2.428E+01	4.801E+01	5.643E+01	1.377E-04	1.477E-05
2.438E+01	5.165E+01	6.071E+01	1.377E-04	1.490E-05
2.448E+01	5.512E+01	6.479E+01	1.377E-04	1.501E-05
2.458E+01	5.843E+01	6.869E+01	1.377E-04	1.513E-05
2.468E+01	6.162E+01	7.244E+01	1.377E-04	1.524E-05
2.478E+01	6.469E+01	7.605E+01	1.377E-04	1.535E-05
2.488E+01	6.765E+01	7.953E+01	1.377E-04	1.545E-05
2.498E+01	7.052E+01	8.290E+01	1.377E-04	1.555E-05
2.508E+01	7.330E+01	8.617E+01	1.377E-04	1.565E-05
2.518E+01	7.600E+01	8.935E+01	1.377E-04	1.575E-05
2.528E+01	7.862E+01	9.244E+01	1.377E-04	1.585E-05
2.628E+01	1.017E+02	1.196E+02	1.377E-04	1.672E-05
2.728E+01	1.210E+02	1.423E+02	1.377E-04	1.750E-05
2.828E+01	1.377E+02	1.620E+02	1.377E-04	1.821E-05
2.928E+01	2.793E+02	3.295E+02	2.796E+03	3.972E+02
2.990E+01	3.799E+02	4.491E+02	4.003E+03	5.943E+02
3.030E+01	3.909E+02	4.623E+02	4.102E+03	6.200E+02
3.130E+01	3.887E+02	4.597E+02	4.077E+03	6.218E+02

TABLE 6.2-38 (Cont'd)

DOUBLE-ENDED PUMP SUCTION BREAK MINIMUM SAFEGUARDS REFLOOD
MASS AND ENERGY RELEASES - UNIT 2

TIME (SECONDS)	<u>BREAK PATH NO. 1*</u>		<u>BREAK PATH NO. 2**</u>	
	FLOW (LBM/SEC)	ENERGY (THOUSANDS BTU/SEC)	FLOW (LBM/SEC)	ENERGY (THOUSANDS BTU/SEC)
3.230E+01	3.826E+02	4.524E+02	4.015E+03	6.153E+02
3.330E+01	3.762E+02	4.448E+02	3.949E+03	6.081E+02
3.430E+01	3.699E+02	4.372E+02	3.882E+03	6.005E+02
3.510E+01	3.649E+02	4.313E+02	3.830E+03	5.944E+02
3.530E+01	3.636E+02	4.298E+02	3.816E+03	5.929E+02
3.630E+01	3.576E+02	4.226E+02	3.752E+03	5.853E+02
3.730E+01	3.517E+02	4.156E+02	3.688E+03	5.779E+02
3.830E+01	3.460E+02	4.088E+02	3.627E+03	5.706E+02
3.930E+01	3.405E+02	4.023E+02	3.567E+03	5.636E+02
4.030E+01	3.353E+02	3.960E+02	3.509E+03	5.567E+02
4.130E+01	3.302E+02	3.900E+02	3.452E+03	5.500E+02
4.220E+01	3.258E+02	3.847E+02	3.403E+03	5.441E+02
4.230E+01	3.253E+02	3.841E+02	3.398E+03	5.434E+02
4.330E+01	3.206E+02	3.785E+02	3.344E+03	5.371E+02
4.430E+01	3.160E+02	3.731E+02	3.293E+03	5.309E+02
4.535E+01	3.435E+02	4.058E+02	3.634E+03	5.588E+02
4.635E+01	3.393E+02	4.008E+02	3.587E+03	5.532E+02
4.735E+01	3.352E+02	3.959E+02	3.542E+03	5.477E+02
4.835E+01	3.312E+02	3.912E+02	3.498E+03	5.423E+02
4.935E+01	3.273E+02	3.866E+02	3.456E+03	5.371E+02
5.005E+01	3.247E+02	3.835E+02	3.427E+03	5.336E+02
5.035E+01	3.236E+02	3.821E+02	3.414E+03	5.320E+02
5.135E+01	3.200E+02	3.778E+02	3.374E+03	5.271E+02
5.235E+01	3.165E+02	3.737E+02	3.334E+03	5.222E+02
5.335E+01	3.130E+02	3.696E+02	3.296E+03	5.175E+02
5.435E+01	3.097E+02	3.656E+02	3.258E+03	5.129E+02
5.535E+01	3.065E+02	3.618E+02	3.221E+03	5.084E+02
5.635E+01	3.034E+02	3.581E+02	3.185E+03	5.040E+02
5.735E+01	3.003E+02	3.544E+02	3.150E+03	4.997E+02
5.835E+01	2.973E+02	3.509E+02	3.116E+03	4.955E+02
5.865E+01	2.964E+02	3.499E+02	3.106E+03	4.942E+02
5.935E+01	2.944E+02	3.474E+02	3.083E+03	4.913E+02
6.035E+01	2.916E+02	3.441E+02	3.050E+03	4.873E+02
6.140E+01	2.442E+02	2.879E+02	2.436E+03	4.183E+02
6.240E+01	2.422E+02	2.855E+02	2.410E+03	4.151E+02

TABLE 6.2-38 (Cont'd)

DOUBLE-ENDED PUMP SUCTION BREAK MINIMUM SAFEGUARDS REFLOOD
MASS AND ENERGY RELEASES - UNIT 2

TIME (SECONDS)	<u>BREAK PATH NO. 1*</u>		<u>BREAK PATH NO. 2**</u>	
	FLOW (LBM/SEC)	ENERGY (THOUSANDS BTU/SEC)	FLOW (LBM/SEC)	ENERGY (THOUSANDS BTU/SEC)
6.340E+01	2.402E+02	2.831E+02	2.385E+03	4.120E+02
6.445E+01	4.131E+02	4.887E+02	3.116E+02	2.228E+02
6.545E+01	4.369E+02	5.173E+02	3.217E+02	2.374E+02
6.645E+01	4.267E+02	5.051E+02	3.172E+02	2.313E+02
6.745E+01	4.155E+02	4.917E+02	3.122E+02	2.245E+02
6.845E+01	4.043E+02	4.783E+02	3.072E+02	2.178E+02
6.945E+01	3.942E+02	4.663E+02	3.027E+02	2.118E+02
7.045E+01	3.848E+02	4.550E+02	2.985E+02	2.062E+02
7.145E+01	3.757E+02	4.442E+02	2.945E+02	2.009E+02
7.245E+01	3.670E+02	4.339E+02	2.906E+02	1.958E+02
7.345E+01	3.587E+02	4.239E+02	2.869E+02	1.909E+02
7.445E+01	3.507E+02	4.143E+02	2.834E+02	1.862E+02
7.545E+01	3.429E+02	4.051E+02	2.800E+02	1.818E+02
7.645E+01	3.355E+02	3.963E+02	2.767E+02	1.775E+02
7.745E+01	3.284E+02	3.878E+02	2.736E+02	1.734E+02
7.845E+01	3.215E+02	3.796E+02	2.706E+02	1.694E+02
7.945E+01	3.149E+02	3.718E+02	2.678E+02	1.657E+02
8.045E+01	3.086E+02	3.643E+02	2.650E+02	1.621E+02
8.145E+01	3.025E+02	3.570E+02	2.624E+02	1.587E+02
8.245E+01	2.966E+02	3.501E+02	2.599E+02	1.554E+02
8.345E+01	2.910E+02	3.434E+02	2.574E+02	1.522E+02
8.545E+01	2.804E+02	3.308E+02	2.529E+02	1.463E+02
8.745E+01	2.706E+02	3.192E+02	2.488E+02	1.409E+02
8.945E+01	2.616E+02	3.085E+02	2.450E+02	1.360E+02
9.145E+01	2.533E+02	2.987E+02	2.415E+02	1.315E+02
9.345E+01	2.458E+02	2.897E+02	2.383E+02	1.274E+02
9.545E+01	2.388E+02	2.815E+02	2.354E+02	1.236E+02
9.675E+01	2.346E+02	2.765E+02	2.337E+02	1.214E+02
9.745E+01	2.324E+02	2.739E+02	2.328E+02	1.202E+02
9.945E+01	2.266E+02	2.670E+02	2.304E+02	1.171E+02
1.014E+02	2.212E+02	2.607E+02	2.282E+02	1.143E+02
1.034E+02	2.164E+02	2.549E+02	2.262E+02	1.118E+02
1.054E+02	2.119E+02	2.497E+02	2.243E+02	1.094E+02
1.074E+02	2.079E+02	2.449E+02	2.227E+02	1.073E+02
1.094E+02	2.042E+02	2.405E+02	2.212E+02	1.054E+02

TABLE 6.2-38 (Cont'd)

DOUBLE-ENDED PUMP SUCTION BREAK MINIMUM SAFEGUARDS REFLOOD
MASS AND ENERGY RELEASES - UNIT 2

TIME (SECONDS)	<u>BREAK PATH NO. 1*</u>		<u>BREAK PATH NO. 2**</u>	
	FLOW (LBM/SEC)	ENERGY (THOUSANDS BTU/SEC)	FLOW (LBM/SEC)	ENERGY (THOUSANDS BTU/SEC)
1.114E+02	2.009E+02	2.366E+02	2.199E+02	1.037E+02
1.134E+02	1.979E+02	2.330E+02	2.186E+02	1.022E+02
1.154E+02	1.952E+02	2.299E+02	2.176E+02	1.008E+02
1.174E+02	1.927E+02	2.270E+02	2.166E+02	9.960E+01
1.194E+02	1.906E+02	2.244E+02	2.157E+02	9.848E+01
1.214E+02	1.886E+02	2.221E+02	2.149E+02	9.749E+01
1.234E+02	1.869E+02	2.201E+02	2.142E+02	9.660E+01
1.247E+02	1.858E+02	2.189E+02	2.138E+02	9.608E+01
1.254E+02	1.853E+02	2.182E+02	2.136E+02	9.581E+01
1.274E+02	1.840E+02	2.166E+02	2.130E+02	9.511E+01
1.294E+02	1.828E+02	2.152E+02	2.125E+02	9.449E+01
1.314E+02	1.817E+02	2.140E+02	2.121E+02	9.395E+01
1.334E+02	1.808E+02	2.129E+02	2.117E+02	9.347E+01
1.354E+02	1.800E+02	2.119E+02	2.114E+02	9.306E+01
1.374E+02	1.793E+02	2.111E+02	2.111E+02	9.270E+01
1.394E+02	1.787E+02	2.105E+02	2.109E+02	9.239E+01
1.414E+02	1.783E+02	2.099E+02	2.107E+02	9.213E+01
1.434E+02	1.779E+02	2.094E+02	2.105E+02	9.191E+01
1.454E+02	1.776E+02	2.091E+02	2.103E+02	9.174E+01
1.474E+02	1.773E+02	2.088E+02	2.102E+02	9.159E+01
1.494E+02	1.772E+02	2.086E+02	2.101E+02	9.148E+01
1.514E+02	1.770E+02	2.084E+02	2.101E+02	9.139E+01
1.534E+02	1.769E+02	2.083E+02	2.100E+02	9.132E+01
1.554E+02	1.769E+02	2.083E+02	2.100E+02	9.128E+01
1.570E+02	1.769E+02	2.083E+02	2.100E+02	9.126E+01
1.574E+02	1.769E+02	2.083E+02	2.100E+02	9.126E+01
1.594E+02	1.770E+02	2.084E+02	2.100E+02	9.126E+01
1.614E+02	1.771E+02	2.085E+02	2.100E+02	9.127E+01
1.634E+02	1.772E+02	2.086E+02	2.100E+02	9.130E+01
1.654E+02	1.773E+02	2.088E+02	2.100E+02	9.135E+01
1.674E+02	1.775E+02	2.090E+02	2.101E+02	9.141E+01
1.694E+02	1.777E+02	2.092E+02	2.101E+02	9.148E+01
1.714E+02	1.779E+02	2.095E+02	2.102E+02	9.156E+01
1.734E+02	1.782E+02	2.098E+02	2.103E+02	9.165E+01
1.754E+02	1.784E+02	2.101E+02	2.103E+02	9.175E+01

TABLE 6.2-38 (Cont'd)

DOUBLE-ENDED PUMP SUCTION BREAK MINIMUM SAFEGUARDS REFLOOD
MASS AND ENERGY RELEASES - UNIT 2

TIME (SECONDS)	<u>BREAK PATH NO. 1*</u>		<u>BREAK PATH NO. 2**</u>	
	FLOW (LBM/SEC)	ENERGY (THOUSANDS BTU/SEC)	FLOW (LBM/SEC)	ENERGY (THOUSANDS BTU/SEC)
1.774E+02	1.787E+02	2.104E+02	2.104E+02	9.186E+01
1.794E+02	1.790E+02	2.107E+02	2.105E+02	9.197E+01
1.814E+02	1.793E+02	2.111E+02	2.106E+02	9.209E+01
1.834E+02	1.796E+02	2.115E+02	2.107E+02	9.222E+01
1.854E+02	1.799E+02	2.118E+02	2.108E+02	9.235E+01
1.874E+02	1.802E+02	2.122E+02	2.109E+02	9.248E+01
1.894E+02	1.806E+02	2.126E+02	2.110E+02	9.262E+01
1.914E+02	1.809E+02	2.130E+02	2.112E+02	9.276E+01
1.918E+02	1.810E+02	2.131E+02	2.112E+02	9.279E+01
1.934E+02	1.813E+02	2.134E+02	2.113E+02	9.291E+01
1.954E+02	1.816E+02	2.139E+02	2.114E+02	9.306E+01
1.974E+02	1.820E+02	2.143E+02	2.115E+02	9.321E+01
1.994E+02	1.823E+02	2.147E+02	2.116E+02	9.336E+01
2.014E+02	1.827E+02	2.151E+02	2.117E+02	9.351E+01
2.034E+02	1.830E+02	2.155E+02	2.119E+02	9.366E+01
2.054E+02	1.834E+02	2.159E+02	2.120E+02	9.381E+01
2.074E+02	1.837E+02	2.164E+02	2.121E+02	9.396E+01
2.094E+02	1.841E+02	2.168E+02	2.122E+02	9.411E+01
2.114E+02	1.845E+02	2.172E+02	2.123E+02	9.426E+01
2.134E+02	1.848E+02	2.176E+02	2.125E+02	9.442E+01
2.154E+02	1.852E+02	2.181E+02	2.126E+02	9.458E+01
2.174E+02	1.855E+02	2.185E+02	2.127E+02	9.474E+01
2.194E+02	1.861E+02	2.191E+02	2.129E+02	9.497E+01
2.214E+02	1.871E+02	2.203E+02	2.136E+02	9.548E+01
2.234E+02	1.880E+02	2.214E+02	2.147E+02	9.597E+01

TABLE 6.2-38 (Cont'd)

DOUBLE-ENDED PUMP SUCTION BREAK MINIMUM SAFEGUARDS REFLOOD
MASS AND ENERGY RELEASES - UNIT 2

TIME (SECONDS)	<u>BREAK PATH NO. 1*</u>		<u>BREAK PATH NO. 2**</u>	
	FLOW (LBM/SEC)	ENERGY (THOUSANDS BTU/SEC)	FLOW (LBM/SEC)	ENERGY (THOUSANDS BTU/SEC)
2.254E+02	1.890E+02	2.226E+02	2.161E+02	9.652E+01
2.274E+02	1.900E+02	2.237E+02	2.178E+02	9.710E+01
2.285E+02	1.905E+02	2.244E+02	2.189E+02	9.743E+01

* mass and energy exiting the SG side of the break

** mass and energy exiting the pump side of the break

TABLE 6.2-39

DOUBLE-ENDED PUMP SUCTION BREAK MINIMUM SAFEGUARDS PRINCIPLE PARAMETERS
DURING REFLOOD - UNIT 2

TIME (SECONDS)	<u>FLOODING</u>		CARRY- OVER FRACTION (-)	CORE HEIGHT (FT)	DOWNCOMER HEIGHT (FT)	FLOW FRAC (-)	<u>TOTAL</u>	<u>INJECTION</u> <u>ACCUM</u>	<u>SPILL</u>	ENTHALPY (BTU/LBM)
	TEMP (°F)	RATE (IN/SEC)					(POUNDS	MASS PER	SECOND)	
22.2	191.6	0.000	0.000	0.00	0.00	0.250	0.0	0.0	0.0	0.00
23.1	188.3	21.063	0.000	0.74	1.25	0.000	6719.7	6719.7	0.0	89.66
23.2	187.6	21.557	0.000	0.92	1.19	0.000	6697.5	6697.5	0.0	89.66
23.3	186.9	21.001	0.000	1.10	1.13	0.000	6675.5	6675.5	0.0	89.66
23.6	186.4	2.390	0.102	1.31	1.62	0.191	6586.7	6586.7	0.0	89.66
23.8	186.5	2.670	0.137	1.35	2.15	0.230	6544.8	6544.8	0.0	89.66
24.8	186.7	2.319	0.310	1.50	4.80	0.332	6336.4	6336.4	0.0	89.66
26.3	187.1	2.261	0.466	1.67	8.73	0.357	6067.6	6067.6	0.0	89.66
29.9	188.4	3.909	0.640	2.01	16.10	0.565	5141.3	5141.3	0.0	89.66
31.3	188.9	3.756	0.675	2.16	16.12	0.564	4926.7	4926.7	0.0	89.66
35.1	190.6	3.374	0.716	2.50	16.12	0.557	4554.1	4554.1	0.0	89.66
42.2	194.9	3.002	0.740	3.01	16.12	0.541	4020.6	4020.6	0.0	89.66
44.3	196.2	2.924	0.743	3.14	16.12	0.537	3889.3	3889.3	0.0	89.66
45.4	197.0	3.076	0.745	3.21	16.12	0.553	4271.0	3731.6	0.0	87.58
50.1	200.3	2.930	0.750	3.50	16.12	0.545	4025.4	3481.9	0.0	87.44
58.7	206.4	2.722	0.755	4.00	16.12	0.533	3651.0	3101.8	0.0	87.18

TABLE 6.2-39 (Cont'd)

DOUBLE-ENDED PUMP SUCTION BREAK MINIMUM SAFEGUARDS
PRINCIPLE PARAMETERS DURING REFLOOD - UNIT 2

TIME (SECONDS)	<u>FLOODING</u>		CARRY-OVER FRACTION (-)	CORE HEIGHT (FT)	DOWNCOMER HEIGHT (FT)	FLOW FRAC (-)	<u>TOTAL</u>	<u>INJECTION</u> <u>ACCUM</u>	<u>SPILL</u>	ENTHALPY (BTU/LBM)
	TEMP (°F)	RATE (IN/SEC)					(POUNDS MASS PER SECOND)	PER SECOND	SECOND	
63.4	209.7	2.387	0.755	4.25	16.12	0.492	2839.5	2279.3	0.0	86.41
64.5	210.5	3.392	0.760	4.31	16.02	0.604	523.8	0.0	0.0	73.20
65.5	211.3	3.496	0.760	4.38	15.77	0.607	514.2	0.0	0.0	73.20
67.5	213.1	3.334	0.760	4.51	15.29	0.604	519.8	0.0	0.0	73.20
75.5	220.7	2.802	0.761	5.00	13.82	0.593	536.4	0.0	0.0	73.20
85.5	230.0	2.348	0.761	5.51	12.71	0.579	548.7	0.0	0.0	73.20
96.8	238.3	2.020	0.761	6.00	12.11	0.563	556.6	0.0	0.0	73.20
111.5	246.6	1.779	0.762	6.55	11.94	0.547	561.7	0.0	0.0	73.20
124.8	252.7	1.668	0.765	7.00	12.11	0.538	563.6	0.0	0.0	73.20
141.5	259.1	1.604	0.770	7.53	12.54	0.533	564.5	0.0	0.0	73.20
157.1	264.1	1.583	0.775	8.00	13.03	0.533	564.7	0.0	0.0	73.20
171.5	268.0	1.579	0.780	8.42	13.52	0.534	564.7	0.0	0.0	73.20
175.5	269.0	1.579	0.782	8.54	13.65	0.534	564.6	0.0	0.0	73.20
191.9	272.8	1.583	0.788	9.00	14.21	0.536	564.4	0.0	0.0	73.20
211.5	276.6	1.590	0.795	9.54	14.87	0.539	564.0	0.0	0.0	73.20
228.6	279.4	1.613	0.802	10.00	15.42	0.544	563.3	0.0	0.0	73.20

TABLE 6.2-40

DOUBLE-ENDED PUMP SUCTION BREAK MINIMUM SAFEGUARDS POST-REFLOOD
MASS AND ENERGY RELEASES - UNIT 2

TIME (SECONDS)	<u>BREAK PATH NO.1*</u>		<u>BREAK PATH NO.2**</u>	
	FLOW (LBM/SEC)	ENERGY (THOUSANDS BTU/SEC)	FLOW (LBM/SEC)	ENERGY (THOUSANDS BTU/SEC)
2.286000E+02	2.274218E+02	2.811441E+02	3.469682E+02	1.274728E+02
2.336000E+02	2.276510E+02	2.814274E+02	3.467391E+02	1.272107E+02
2.386000E+02	2.270515E+02	2.806863E+02	3.473386E+02	1.271587E+02
2.436000E+02	2.264192E+02	2.799046E+02	3.479709E+02	1.271146E+02
2.486000E+02	2.265172E+02	2.800258E+02	3.478729E+02	1.268845E+02
2.536000E+02	2.258035E+02	2.791436E+02	3.485865E+02	1.268601E+02
2.586000E+02	2.250552E+02	2.782184E+02	3.493349E+02	1.268441E+02
2.636000E+02	2.250168E+02	2.781710E+02	3.493732E+02	1.266473E+02
2.686000E+02	2.249129E+02	2.780425E+02	3.494772E+02	1.264666E+02
2.736000E+02	2.240187E+02	2.769372E+02	3.503713E+02	1.264864E+02
2.786000E+02	2.238013E+02	2.766684E+02	3.505887E+02	1.263336E+02
2.836000E+02	2.235161E+02	2.763158E+02	3.508739E+02	1.261977E+02
2.886000E+02	2.231622E+02	2.758783E+02	3.512279E+02	1.260788E+02
2.936000E+02	2.227355E+02	2.753508E+02	3.516545E+02	1.259778E+02
2.986000E+02	2.222331E+02	2.747297E+02	3.521570E+02	1.258957E+02
3.036000E+02	2.216537E+02	2.740135E+02	3.527363E+02	1.258327E+02
3.086000E+02	2.216550E+02	2.740151E+02	3.527350E+02	1.256216E+02
3.136000E+02	2.208885E+02	2.730675E+02	3.535015E+02	1.256052E+02
3.186000E+02	2.206754E+02	2.728041E+02	3.537146E+02	1.254476E+02
3.236000E+02	2.203381E+02	2.723870E+02	3.540520E+02	1.253213E+02
3.286000E+02	2.198674E+02	2.718052E+02	3.545226E+02	1.252282E+02
3.336000E+02	2.192580E+02	2.710519E+02	3.551320E+02	1.251700E+02
3.386000E+02	2.191012E+02	2.708580E+02	3.552889E+02	1.249963E+02
3.436000E+02	2.187536E+02	2.704282E+02	3.556365E+02	1.248706E+02
3.486000E+02	2.181974E+02	2.697406E+02	3.561927E+02	1.247974E+02
3.536000E+02	2.174260E+02	2.687870E+02	3.569641E+02	1.247784E+02
3.586000E+02	2.175108E+02	2.688919E+02	3.568792E+02	1.245414E+02
3.636000E+02	2.167234E+02	2.679185E+02	3.576667E+02	1.245255E+02
3.686000E+02	2.161262E+02	2.671802E+02	3.582639E+02	1.244609E+02
3.736000E+02	2.161282E+02	2.671827E+02	3.582619E+02	1.242434E+02
3.786000E+02	2.155824E+02	2.665080E+02	3.588077E+02	1.241647E+02

TABLE 6.2-40 (Cont'd)

DOUBLE-ENDED PUMP SUCTION BREAK MINIMUM SAFEGUARDS POST-REFLOOD
MASS AND ENERGY RELEASES - UNIT 2

TIME (SECONDS)	<u>BREAK PATH NO.1*</u>		<u>BREAK PATH NO.2**</u>	
	FLOW (LBM/SEC)	ENERGY (THOUSANDS BTU/SEC)	FLOW (LBM/SEC)	ENERGY (THOUSANDS BTU/SEC)
3.836000E+02	2.148698E+02	2.656271E+02	3.595202E+02	1.241278E+02
3.886000E+02	2.147350E+02	2.654604E+02	3.596550E+02	1.239437E+02
3.936000E+02	2.139451E+02	2.644839E+02	3.604450E+02	1.239255E+02
3.986000E+02	2.137580E+02	2.642526E+02	3.606320E+02	1.237537E+02
4.036000E+02	2.130554E+02	2.633841E+02	3.613346E+02	1.237184E+02
4.086000E+02	2.126190E+02	2.628445E+02	3.617711E+02	1.236173E+02
4.136000E+02	2.122196E+02	2.623509E+02	3.621704E+02	1.235062E+02
4.186000E+02	2.118793E+02	2.619301E+02	3.625108E+02	1.233797E+02
5.914250E+02	2.118793E+02	2.619301E+02	3.625108E+02	1.233797E+02
5.915250E+02	9.650713E+01	1.187123E+02	4.778829E+02	1.503192E+02
5.936000E+02	9.642737E+01	1.186137E+02	4.779627E+02	1.502350E+02
1.108600E+03	8.450732E+01	1.038779E+02	4.898827E+02	1.463327E+02
1.110000E+03	8.448491E+01	1.038502E+02	3.452051E+02	1.685844E+02
1.542848E+03	8.448491E+01	1.038502E+02	3.452051E+02	1.685844E+02
1.542948E+03	7.763659E+01	8.932996E+01	3.520534E+02	6.785473E+01
3.000000E+03	6.607184E+01	7.602336E+01	3.636182E+02	6.994120E+01
3.000100E+03	6.607121E+01	7.602263E+01	3.636188E+02	6.994131E+01
3.600000E+03	6.228181E+01	7.166248E+01	3.674082E+02	7.062498E+01
3.600100E+03	5.368262E+01	6.176812E+01	3.760074E+02	5.640111E+01
1.000000E+04	3.903592E+01	4.491538E+01	3.906541E+02	5.859811E+01
1.000010E+04	3.819605E+01	4.394901E+01	3.914940E+02	5.011123E+01
3.000000E+04	2.904561E+01	3.342036E+01	4.006444E+02	5.128248E+01
3.000010E+04	2.848841E+01	3.277924E+01	4.012016E+02	4.332977E+01
1.000000E+05	2.002906E+01	2.304577E+01	4.096609E+02	4.424338E+01
1.000001E+05	1.983878E+01	2.282683E+01	4.098512E+02	4.016542E+01
1.000000E+06	8.500924E+00	9.781305E+00	4.211891E+02	4.127653E+01
1.0000001E+06	8.476764E+00	9.753506E+00	4.212132E+02	4.001526E+01
1.0000000E+07	2.654739E+00	3.054587E+00	4.270353E+02	4.056835E+01
1.00000001E+07	2.637251E+00	3.034464E+00	4.270527E+02	3.758064E+01

* mass and energy exiting the SG side of the break

** mass and energy exiting the pump side of the break

TABLE 6.2-41

DOUBLE-ENDED PUMP SUCTION BREAK MASS BALANCE
MINIMUM SAFEGUARDS - UNIT 2

TIME (SECONDS)		Mass Balance						
		0.00	22.20	22.20	228.55	591.53	1542.85	3600.00
		MASS (THOUSAND LBM)						
Initial	In RCS and ACC	761.83	761.83	761.83	761.83	761.83	761.83	761.83
Added Mass	Pumped Injection	0.00	0.00	0.00	102.72	311.18	794.98	1678.92
	Total Added	0.00	0.00	0.00	102.72	311.18	794.98	1678.92
TOTAL AVAILABLE		761.83	761.83	761.83	864.55	1073.01	1556.81	2440.75
Distribution	Reactor Coolant	511.41	55.96	79.47	141.33	141.33	141.33	141.33
	Accumulator	250.42	196.52	173.01	-0.00	0.00	0.00	0.00
	Total Contents	761.83	252.48	252.48	141.33	141.33	141.33	141.33
Effluent	Break Flow	0.00	509.35	509.35	711.62	920.08	1403.78	2287.71
	ECCS Spill	0.00	0.00	0.00	0.00	0.00	0.00	0.00
	Total Effluent	0.00	509.35	509.35	711.62	920.08	1403.78	2287.71
TOTAL ACCOUNTABLE		761.83	761.83	761.83	852.96	1061.42	1545.11	2429.05

TABLE 6.2-42

DOUBLE-ENDED PUMP SUCTION BREAK ENERGY BALANCE
MINIMUM SAFEGUARDS - UNIT 2

TIME (SECONDS)	ENERGY BALANCE								
	0.00	22.20	22.20	228.55	591.53	1542.85	3600.00		
		ENERGY (MILLION BTU)							
Initial Energy	In RCS, ACC, S Gen	835.56	835.56	835.56	835.56	835.56	835.56	835.56	835.56
Added Energy	Pumped Injection	0.00	0.00	0.00	7.52	22.78	72.48	205.07	
	Decay Heat	0.00	7.52	7.52	32.77	67.23	140.07	263.13	
	Heat from Secondary	0.00	18.34	18.34	18.34	18.34	18.34	18.34	
	Total Added	0.00	25.86	25.86	58.63	108.35	230.89	486.54	
TOTAL AVAILABLE		835.56	861.42	861.42	894.19	943.91	1066.45	1322.1	
Distribution	Reactor Coolant	309.15	12.29	14.40	36.51	36.51	36.51	36.51	
	Accumulator	22.41	17.59	15.48	-0.00	0.00	0.00	0.00	
	Core Stored	23.01	11.66	11.66	4.67	4.55	4.16	3.33	
	Primary Metal	160.32	153.36	153.36	115.99	84.34	59.49	46.20	
	Secondary Metal	73.35	73.82	73.82	66.39	54.72	34.06	25.99	
	Steam Generator	247.33	270.71	270.71	235.54	186.85	112.41	84.99	
	Total Contents	835.56	539.43	539.43	459.09	366.96	246.63	197.02	
Effluent	Break Flow	0.00	321.41	321.41	413.43	555.28	808.07	1115.42	
	ECCS Spill	0.00	0.00	0.00	0.00	0.00	0.00	0.00	
	Total Effluent	0.00	321.41	321.41	413.43	555.28	808.07	1115.42	
TOTAL ACCOUNTABLE		835.56	860.85	860.85	872.52	922.25	1054.70	1312.44	

B/B-UFSAR

TABLE 6.2-43

DOUBLE-ENDED PUMP SUCTION BREAK MAXIMUM SAFEGUARDS BLOWDOWN
MASS AND ENERGY RELEASES - UNIT 2

Time (sec)	Break Path No. 1*		Break Path No. 2**	
	Flow (lbm/sec)	Energy (1000 BTU/sec)	Flow (lbm/sec)	Energy (1000 BTU/sec)
0.00000	0.0	0.0	0.0	0.0
0.00110	87607.2	49361.2	43219.8	24298.4
0.101	42805.0	24152.4	22312.0	12531.3
0.201	43760.8	24902.9	24742.7	13908.5
0.302	44964.2	25889.5	24946.0	14035.9
0.401	46001.0	26848.2	24135.6	13593.8
0.502	46551.9	27553.0	23023.5	12977.1
0.602	46199.9	27696.9	22097.2	12460.1
0.701	44824.7	27177.3	21289.6	12007.5
0.802	43056.2	26378.2	20686.6	11670.4
0.902	41384.8	25588.1	20272.2	11440.3
1.00	39914.4	24877.6	20049.0	11317.2
1.10	38662.7	24273.8	19922.5	11247.5
1.20	37624.8	23785.6	19866.0	11216.7
1.30	36787.4	23408.7	19835.2	11199.8
1.40	36074.2	23099.6	19811.0	11186.0
1.50	35427.9	22826.3	19797.9	11178.1
1.60	34810.7	22570.8	19812.9	11186.1
1.70	34211.1	22328.9	19844.3	11203.6
1.80	33541.9	22043.6	19862.7	11213.7
1.90	32892.9	21769.2	19847.5	11204.7
2.00	32174.9	21448.6	19784.1	11168.3
2.10	31436.5	21109.7	19707.2	11124.7
2.20	30679.3	20754.8	19611.5	11070.9
2.30	29882.0	20365.4	19460.5	10985.7
2.40	29029.5	19931.6	19008.3	10729.4
2.50	28149.6	19473.5	18762.7	10592.2
2.60	27069.7	18864.2	18575.6	10487.9
2.70	25656.6	18000.8	18364.7	10370.1
2.80	23583.9	16643.6	18136.3	10242.6
2.90	21815.6	15494.5	17905.4	10114.0
3.00	21223.0	15171.4	17674.8	9985.8
3.10	20717.6	14866.0	17452.5	9862.5
3.20	20012.5	14401.5	17239.4	9744.6
3.30	19464.3	14047.1	17019.9	9623.1
3.40	18821.8	13614.5	16815.6	9510.4
3.50	18171.0	13170.9	16621.3	9403.6
3.60	17514.7	12718.6	16432.8	9300.1

B/B-UFSAR

TABLE 6.2-43 (Cont'd)

DOUBLE-ENDED PUMP SUCTION BREAK MAXIMUM SAFEGUARDS BLOWDOWN
MASS AND ENERGY RELEASES - UNIT 2

Time (sec)	Break Path No. 1*		Break Path No. 2**	
	Flow (lbm/sec)	Energy (1000 BTU/sec)	Flow (lbm/sec)	Energy (1000 BTU/sec)
3.70	16893.6	12288.7	16269.1	9210.9
3.80	16314.1	11885.5	16106.6	9122.4
3.90	15793.5	11521.9	15952.5	9038.7
4.00	15345.6	11209.2	15816.0	8965.2
4.20	14628.9	10703.3	15540.7	8816.6
4.40	14090.9	10317.1	15274.6	8673.4
4.60	13670.1	10005.8	15021.6	8536.3
4.80	13376.7	9779.4	14827.7	8426.0
5.00	13229.0	9649.6	14649.6	8325.4
5.20	13113.7	9537.7	15800.5	8988.6
5.40	13015.7	9438.0	15867.1	9021.3
5.60	12953.3	9362.0	15870.0	9025.3
5.80	12915.7	9304.7	15751.2	8958.9
6.00	12842.8	9228.8	15562.9	8852.5
6.20	12729.3	9132.9	15372.3	8744.7
6.40	12589.8	9025.6	15199.1	8646.5
6.60	12421.3	8904.4	15034.5	8552.2
6.80	12271.7	8801.8	14926.5	8489.6
7.00	12138.0	8705.7	14841.7	8438.7
7.20	12018.3	8613.1	14675.8	8340.5
7.40	12225.7	8748.2	14517.0	8246.1
7.60	11917.1	8546.3	14492.1	8229.1
7.80	10995.4	8410.4	14435.4	8192.6
8.00	9788.7	7889.4	14108.0	8001.6
8.20	9673.1	7779.7	13913.2	7887.1
8.40	9717.1	7722.2	13821.4	7832.9
8.60	9725.4	7643.2	13643.0	7728.7
8.80	9775.9	7592.9	13369.9	7570.0
9.00	9862.1	7560.5	13238.9	7493.0
9.20	9925.8	7511.0	13080.5	7399.9
9.40	9967.1	7453.1	12851.1	7266.1
9.60	9986.0	7389.1	12713.7	7184.8
9.80	9958.4	7304.6	12550.6	7088.6
10.0	9878.7	7196.7	12367.4	6980.8
10.2	9775.2	7085.5	12235.8	6902.6
10.4	9623.9	6950.4	12071.1	6805.4
10.6	9440.5	6807.0	11931.7	6722.8
10.8	9263.2	6677.9	11794.1	6641.2
11.0	9058.7	6535.7	11644.6	6552.9
11.2	8862.9	6406.7	11524.3	6481.4
11.4	8667.0	6280.8	11376.9	6394.6
11.6	8471.1	6158.0	11251.5	6320.4
11.8	8283.9	6043.0	11120.4	6243.1
12.0	8096.5	5929.6	10986.0	6164.2

B/B-UFSAR

TABLE 6.2-43 (Cont'd)

DOUBLE-ENDED PUMP SUCTION BREAK MAXIMUM SAFEGUARDS BLOWDOWN
MASS AND ENERGY RELEASES - UNIT 2

Time (sec)	Break Path No. 1*		Break Path No. 2**	
	Flow (lbm/sec)	Energy (1000 BTU/sec)	Flow (lbm/sec)	Energy (1000 BTU/sec)
12.2	7917.2	5823.4	10864.0	6092.4
12.4	7740.1	5719.7	10729.0	6013.5
12.6	7572.2	5623.2	10606.8	5941.9
12.8	7404.8	5526.3	10477.4	5866.4
13.0	7238.8	5430.6	10357.7	5796.6
13.2	7085.1	5348.0	10231.5	5723.3
13.4	6930.2	5264.0	10105.3	5650.1
13.6	6784.0	5182.2	9987.2	5581.9
13.8	6642.9	5100.8	9854.4	5505.4
14.0	6500.5	5018.2	9724.8	5431.0
14.2	6343.5	4924.9	9560.7	5337.2
14.4	6181.5	4825.5	9418.0	5255.8
14.6	6020.1	4720.0	9258.2	5165.0
14.8	5874.0	4619.6	9120.6	5087.2
15.0	5740.5	4524.1	8974.0	5004.8
15.2	5619.2	4436.0	8845.1	4932.9
15.4	5516.1	4360.8	8728.6	4868.7
15.6	5430.9	4302.9	8568.2	4788.4
15.8	5363.8	4290.3	8384.1	4711.6
16.0	5234.6	4281.0	8060.5	4546.8
16.2	5065.2	4265.0	7997.0	4526.1
16.4	4883.6	4244.9	7600.1	4307.4
16.6	4699.4	4228.3	7519.9	4256.8
16.8	4485.8	4190.6	7145.4	4014.4
17.0	4217.0	4110.6	6926.2	3834.6
17.2	3927.6	4017.6	6656.1	3599.3
17.4	3615.9	3881.0	6346.6	3332.4
17.6	3319.3	3718.1	5947.4	3024.2
17.8	3050.4	3539.2	5574.5	2750.3
18.0	2808.3	3347.8	5242.3	2515.3
18.2	2595.5	3153.4	4928.0	2302.5
18.4	2389.5	2932.9	4626.6	2108.3
18.6	2205.5	2724.1	4414.4	1964.1
18.8	2050.9	2544.3	4203.8	1829.8
19.0	1913.4	2381.2	4004.9	1707.5
19.2	1800.6	2246.5	3734.5	1562.0
19.4	1695.5	2120.0	3334.6	1365.0
19.6	1598.6	2002.2	2996.7	1193.2
19.8	1494.2	1874.3	3298.0	1268.8
20.0	1381.9	1736.6	3954.8	1486.3
20.2	1275.6	1605.4	4455.1	1658.3
20.4	1180.2	1488.0	4292.7	1586.2
20.6	1109.1	1400.0	3143.1	1156.2
20.8	1022.9	1293.2	2807.7	1032.5

TABLE 6.2-43 (Cont'd)

DOUBLE-ENDED PUMP SUCTION BREAK MAXIMUM SAFEGUARDS BLOWDOWN
MASS AND ENERGY RELEASES - UNIT 2

Time (sec)	Break Path No. 1*		Break Path No. 2**	
	Flow (lbm/sec)	Energy (1000 BTU/sec)	Flow (lbm/sec)	Energy (1000 BTU/sec)
21.0	948.9	1201.1	2453.8	901.5
21.2	880.3	1115.4	2177.7	800.2
21.4	818.6	1038.2	1505.6	552.6
21.6	711.6	902.7	702.6	254.8
21.8	599.3	761.2	1043.2	333.8
22.0	515.7	655.6	4091.7	1150.7
22.2	435.8	554.5	6502.8	1797.9
22.4	378.6	482.0	6906.6	1909.9
22.6	308.9	393.6	7058.2	1954.4
22.8	252.9	322.5	6933.5	1921.3
23.0	188.0	239.9	6311.1	1748.7
23.2	83.9	107.3	4284.0	1185.6
23.4	57.6	73.9	2352.1	648.0
23.6	41.9	53.8	0.0	0.0
23.8	0.0	0.0	0.0	0.0

* mass and energy exiting the SG side of the break

** mass and energy exiting the pump side of the break

B/B-UFSAR

TABLE 6.2-44

DOUBLE-ENDED PUMP SUCTION BREAK MAXIMUM SAFEGUARDS REFLOOD
MASS AND ENERGY RELEASES - UNIT 2

Time (sec)	Break Path No. 1*		Break Path No. 2**	
	Flow (lbm/sec)	Energy (1000 BTU/sec)	Flow (lbm/sec)	Energy (1000 BTU/sec)
23.8	0.0	0.0	0.0	0.0
24.4	0.0	0.0	0.0	0.0
24.6	0.0	0.0	0.0	0.0
24.7	0.0	0.0	0.0	0.0
24.8	0.0	0.0	0.0	0.0
24.9	0.0	0.0	0.0	0.0
25.0	17.8	20.9	0.0	0.0
25.1	41.0	48.4	0.0	0.0
25.2	20.8	24.6	0.0	0.0
25.3	14.9	17.6	0.0	0.0
25.4	17.3	20.4	0.0	0.0
25.5	23.4	27.6	0.0	0.0
25.6	30.3	35.7	0.0	0.0
25.7	38.0	44.8	0.0	0.0
25.8	43.7	51.6	0.0	0.0
25.9	47.7	56.2	0.0	0.0
26.0	51.7	61.0	0.0	0.0
26.1	55.6	65.5	0.0	0.0
26.2	59.2	69.8	0.0	0.0
26.3	62.7	74.0	0.0	0.0
26.4	66.1	77.9	0.0	0.0
26.5	69.3	81.8	0.0	0.0
26.6	72.5	85.5	0.0	0.0
26.7	75.5	89.0	0.0	0.0
26.8	78.4	92.5	0.0	0.0
26.9	81.3	95.9	0.0	0.0
27.9	106.4	125.5	0.0	0.0
28.9	127.0	149.9	0.0	0.0
29.9	144.9	170.9	0.0	0.0
30.9	218.9	258.5	1669.0	213.9
31.2	421.0	498.9	4083.6	590.4
31.9	508.5	603.6	4935.4	746.9
32.9	509.1	604.3	4936.5	754.4
33.9	503.0	597.0	4882.4	748.2
34.9	496.3	589.0	4822.6	741.0
35.4	492.9	585.0	4791.9	737.1
35.9	489.6	580.9	4761.1	733.3
36.9	482.8	572.8	4699.4	725.4

B/B-UFSAR

TABLE 6.2-44 (Cont'd)

DOUBLE-ENDED PUMP SUCTION BREAK MAXIMUM SAFEGUARDS REFLOOD
MASS AND ENERGY RELEASES - UNIT 2

Time (sec)	Break Path No. 1*		Break Path No. 2**	
	Flow (lbm/sec)	Energy (1000 BTU/sec)	Flow (lbm/sec)	Energy (1000 BTU/sec)
37.9	476.2	565.0	4638.5	717.6
38.9	469.8	557.3	4578.6	709.9
39.9	463.6	549.8	4520.0	702.3
40.7	458.7	544.0	4474.2	696.4
40.9	457.5	542.6	4462.9	694.9
41.9	451.7	535.6	4407.3	687.6
42.9	446.0	528.8	4353.2	680.6
43.9	440.6	522.3	4300.6	673.7
44.9	435.3	516.0	4249.3	667.0
45.9	430.2	509.9	4199.5	660.5
46.8	425.7	504.5	4155.8	654.7
46.9	425.2	503.9	4151.0	654.1
47.9	420.4	498.2	4103.8	647.9
48.9	415.7	492.6	4057.8	641.8
49.9	411.2	487.2	4013.0	635.9
50.9	406.8	482.0	3969.3	630.2
51.9	402.5	476.9	3926.8	624.5
52.9	398.4	471.9	3885.2	619.0
53.5	395.9	469.0	2860.8	615.8
53.9	394.3	467.1	3844.7	613.6
54.9	390.4	462.4	3805.1	608.4
55.9	386.6	457.8	3766.4	603.2
56.9	382.8	453.4	3728.6	598.2
57.9	379.2	449.0	3691.6	593.3
58.9	375.6	444.8	3655.5	588.4
59.9	372.1	440.6	3620.1	583.7
60.9	368.7	436.6	3585.4	579.0
61.9	365.4	432.6	3551.5	574.4
62.9	362.2	428.7	3518.3	569.9
63.9	359.0	424.9	3485.7	565.5
64.9	355.8	421.2	3453.7	561.2
65.9	352.8	417.6	3422.4	556.9
66.9	349.8	414.0	3391.6	552.7
67.9	346.8	410.5	3361.4	548.6
68.4	345.4	408.7	3346.5	546.5
68.9	343.9	407.0	3331.8	544.5
69.9	341.1	403.7	3302.7	540.5
70.9	338.3	400.3	3274.1	536.6
71.9	335.6	397.1	3245.9	532.7
72.9	332.9	393.9	3218.3	528.9
74.0	223.0	263.4	1880.3	360.4
75.0	222.1	262.3	1872.4	359.0
76.0	221.2	261.3	1864.5	357.6

B/B-UFSAR

TABLE 6.2-44 (Cont'd)

DOUBLE-ENDED PUMP SUCTION BREAK MAXIMUM SAFEGUARDS REFLOOD
MASS AND ENERGY RELEASES - UNIT 2

Time (sec)	Break Path No. 1*		Break Path No. 2**	
	Flow (lbm/sec)	Energy (1000 BTU/sec)	Flow (lbm/sec)	Energy (1000 BTU/sec)
77.0	186.6	220.3	1328.1	279.5
78.0	186.3	220.0	1328.8	279.3
79.0	186.0	219.6	1329.5	279.2
80.0	185.8	219.3	1330.1	279.1
81.0	185.5	219.0	1330.8	278.9
82.0	185.2	218.7	1331.5	278.8
83.0	184.9	218.3	1332.2	278.6
84.0	184.7	218.0	1332.9	278.5
85.0	184.4	217.7	1333.5	278.4
87.0	183.9	217.1	1334.9	278.1
88.1	183.6	216.7	1335.7	277.9
89.0	183.4	216.4	1336.3	277.8
91.0	182.8	215.8	1337.7	277.5
93.0	182.3	215.2	1339.1	277.3
95.0	181.8	214.6	1340.5	277.0
97.0	181.3	214.0	1342.0	276.7
99.0	180.8	213.4	1343.4	276.4
101.0	180.3	212.8	1344.8	276.2
103.0	179.8	212.2	1346.3	275.9
105.0	179.3	211.7	1347.7	275.6
107.0	178.8	211.1	1349.1	275.4
109.0	178.3	210.5	1350.6	275.1
111.0	177.8	209.9	1352.0	274.8
111.2	177.8	209.9	1352.1	274.8
113.0	177.4	209.4	1353.4	274.5
115.0	176.9	208.8	1354.8	274.2
117.0	176.4	208.2	1356.2	273.9
119.0	175.9	207.7	1357.5	273.6
121.0	175.4	207.1	1358.9	273.3
123.0	175.0	206.5	1360.2	273.0
125.0	174.5	206.0	1361.6	272.7
127.0	174.0	205.4	1362.9	272.3
129.0	173.6	204.9	1364.2	272.0
131.0	173.1	204.3	1365.6	271.7
133.0	172.7	203.8	1366.9	271.4
135.0	172.2	203.3	1368.2	271.0
136.2	171.9	202.9	1368.9	270.8
137.0	171.8	202.7	1369.4	270.7
139.0	171.3	202.2	1370.7	270.3
141.0	170.9	201.7	1372.0	270.0
143.0	170.4	201.1	1373.2	269.7
145.0	170.0	200.6	1374.5	269.3
147.0	169.5	200.1	1375.7	268.9
149.0	169.1	199.6	1377.0	268.6

B/B-UFSAR

TABLE 6.2-44 (Cont'd)

DOUBLE-ENDED PUMP SUCTION BREAK MAXIMUM SAFEGUARDS REFLOOD
MASS AND ENERGY RELEASES - UNIT 2

Time (sec)	Break Path No. 1*		Break Path No. 2**	
	Flow (lbm/sec)	Energy (1000 BTU/sec)	Flow (lbm/sec)	Energy (1000 BTU/sec)
151.0	168.7	199.1	1378.2	268.2
153.0	168.2	198.6	1379.4	267.9
155.0	167.8	198.1	1380.7	267.5
157.0	167.4	197.6	1381.9	267.1
159.0	166.9	197.0	1383.1	266.7
161.0	166.5	196.5	1384.3	266.4
163.0	166.1	196.0	1385.5	266.0
163.4	166.0	195.9	1385.7	265.9
165.0	165.7	195.5	1386.7	265.6
167.0	165.3	195.1	1387.9	265.2
169.0	164.9	194.6	1389.0	264.8
171.0	164.4	194.1	1390.2	264.4
173.0	164.0	193.6	1391.4	264.0
175.0	163.6	193.1	1392.5	263.6
177.0	163.2	192.6	1393.7	263.2
179.0	162.8	192.2	1394.8	262.8
181.0	162.4	191.7	1396.0	262.4
183.0	162.0	191.2	1397.1	262.0
185.0	161.6	190.8	1398.2	261.6
187.0	161.2	190.3	1399.4	261.2
189.0	160.9	189.8	1400.5	260.8
191.0	160.5	189.4	1401.6	260.4
193.0	160.1	188.9	1402.7	260.0
193.5	160.0	188.8	1403.0	259.9

* mass and energy exiting the SG side of the break

** mass and energy exiting the pump side of the break

B/B-UFSAR

TABLE 6.2-45

DOUBLE-ENDED PUMP SUCTION BREAK-MAXIMUM SAFEGUARDS PRINCIPLE PARAMETERS
DURING REFLOOD - UNIT 2

Time (sec)	<u>Flooding</u>			Core Height (ft)	Downcomer Height (ft)	Flow Fraction	<u>Flow (lbm/sec)</u>			Enthalpy (BTU/lbm)
	Temp (°F)	Rate (in/sec)	Carryover Fraction				Total	Injection Accum	Spill	
23.8	176.9	0.000	0.000	0.00	0.00	0.250	0.0	0.0	0.0	0.00
24.6	175.2	8.963	0.000	0.54	1.23	0.000	6431.7	6431.7	0.0	99.46
24.8	174.2	0.665	0.000	0.87	1.13	0.000	6387.5	6387.5	0.0	99.46
24.9	173.8	0.231	0.000	1.04	1.07	0.000	6365.7	6365.7	0.0	99.46
25.3	173.5	1.954	0.108	1.32	1.65	0.254	6259.5	6259.5	0.0	99.46
25.6	173.6	2.760	0.158	1.37	2.41	0.265	6198.0	6198.0	0.0	99.46
26.4	173.8	2.449	0.300	1.50	4.40	0.331	6031.5	6031.5	0.0	99.46
27.9	174.4	2.386	0.462	1.68	8.11	0.357	5763.0	5763.0	0.0	99.46
31.2	176.1	4.329	0.633	2.00	15.99	0.572	6456.1	4766.3	0.0	96.46
31.9	176.5	4.749	0.655	2.10	16.12	0.603	6135.9	4446.7	0.0	96.30
32.9	177.1	4.580	0.679	2.23	16.12	0.602	5996.7	4307.5	0.0	96.23
35.4	178.7	4.268	0.710	2.51	16.12	0.600	5747.1	4057.8	0.0	96.09
40.7	182.6	3.901	0.733	3.00	16.12	0.592	5320.2	3630.7	0.0	95.82
46.8	187.5	3.634	0.743	3.50	16.12	0.582	4928.5	3238.8	0.0	95.53
53.5	192.9	3.416	0.747	4.00	16.12	0.573	4576.3	2886.4	0.0	95.23
60.9	198.9	3.224	0.750	4.52	16.12	0.563	4251.6	2561.6	0.0	94.90
68.4	204.8	3.059	0.751	5.01	16.12	0.555	3971.4	2281.3	0.0	94.58
77.0	210.8	2.168	0.743	5.49	16.12	0.428	1690.7	0.0	0.0	88.00
78.0	211.5	2.163	0.743	5.54	16.12	0.428	1690.7	0.0	0.0	88.00
88.1	218.6	2.115	0.745	6.00	16.12	0.430	1690.7	0.0	0.0	88.00
101.0	228.7	2.054	0.748	6.57	16.12	0.434	1690.7	0.0	0.0	88.00
111.2	236.6	2.006	0.751	7.00	16.12	0.436	1690.7	0.0	0.0	88.00
125.0	245.9	1.942	0.754	7.57	16.12	0.440	1690.7	0.0	0.0	88.00
136.2	252.3	1.892	0.757	8.00	16.12	0.443	1690.7	0.0	0.0	88.00
151.0	259.6	1.828	0.760	8.56	16.12	0.448	1690.7	0.0	0.0	88.00
163.4	264.8	1.776	0.763	9.00	16.12	0.452	1690.7	0.0	0.0	88.00
179.0	270.4	1.712	0.767	9.53	16.12	0.458	1690.7	0.0	0.0	88.00
193.5	274.9	1.654	0.770	10.00	16.12	0.464	1690.7	0.0	0.0	88.00

TABLE 6.2-46

DOUBLE-ENDED PUMP SUCTION BREAK MAXIMUM SAFEGUARDS POST-REFLOOD
MASS AND ENERGY RELEASES - UNIT 2

Time (sec)	Break Path No. 1*		Break Path No. 2**	
	Flow (lbm/sec)	Energy (1000 BTU/sec)	Flow (lbm/sec)	Energy (1000 BTU/sec)
193.5	173.0	216.2	1517.9	262.2
198.5	173.1	216.4	1517.8	261.9
203.5	172.4	215.5	1518.4	261.8
208.5	172.8	216.0	1518.1	261.5
213.5	172.2	215.3	1518.6	261.3
218.5	172.6	215.7	1518.3	261.0
223.5	172.0	215.0	1518.8	260.9
228.5	172.3	215.5	1518.5	260.5
233.5	172.7	215.9	1518.2	260.2
238.5	172.1	215.1	1518.8	260.1
243.5	172.4	215.5	1518.4	259.7
248.5	171.8	214.8	1519.0	259.6
253.5	172.1	215.1	1518.7	259.3
258.5	171.5	214.4	1519.4	259.2
263.5	171.8	214.7	1519.1	258.8
268.5	172.0	215.1	1518.8	258.5
273.5	171.4	214.3	1519.4	258.4
278.5	171.6	214.6	1519.2	258.0
283.5	171.9	214.9	1519.0	257.7
288.5	171.2	214.1	1519.6	257.6
293.5	171.4	214.3	1519.4	257.3
298.5	171.7	214.6	1519.2	257.0
303.5	171.0	213.7	1519.9	256.9
308.5	171.2	214.0	1519.7	256.5
313.5	171.3	214.2	1519.5	256.2
318.5	170.6	213.3	1520.2	256.1
323.5	170.8	213.5	1520.1	255.8
328.5	170.9	213.6	1519.9	255.5
333.5	171.0	213.8	1519.8	255.2
338.5	171.1	213.9	1519.7	254.9
343.5	170.3	213.0	1520.5	254.8
348.5	170.4	213.1	1520.4	254.5
353.5	170.5	213.1	1520.4	254.2

TABLE 6.2-46 (Cont'd)

<u>DOUBLE-ENDED PUMP SUCTION BREAK MAXIMUM SAFEGUARDS POST-REFLOOD</u>				
<u>MASS AND ENERGY RELEASES - UNIT 2</u>				
Time (sec)	Break Path No. 1*		Break Path No. 2**	
	Flow (lbm/sec)	Energy (1000 BTU/sec)	Flow (lbm/sec)	Energy (1000 BTU/sec)
358.5	170.5	213.2	1520.3	253.9
363.5	170.5	213.2	1520.3	253.6
368.5	170.5	213.2	1520.3	253.4
373.5	170.5	213.2	1520.3	253.1
378.5	170.5	213.1	1520.4	252.8
383.5	170.4	213.0	1520.4	252.5
388.5	170.3	212.9	1520.5	252.3
393.5	170.2	212.8	1520.6	252.0
398.5	170.1	212.6	1520.8	251.8
403.5	170.0	212.6	1520.8	251.5
408.5	170.0	212.5	1520.8	251.2
413.5	170.0	212.5	1520.9	251.0
418.5	169.9	212.4	1520.9	250.7
423.5	169.8	212.3	1521.0	250.4
428.5	169.7	212.1	1521.2	250.2
433.5	169.6	211.9	1521.3	249.9
438.5	169.3	211.7	1521.5	249.7
443.5	169.1	211.5	1521.7	249.5
448.5	169.6	212.0	1521.2	249.1
453.5	169.3	211.7	1521.5	248.9
458.5	169.0	211.3	1521.8	248.6
463.5	169.3	211.7	1521.5	248.3
468.5	168.9	211.2	1521.9	248.1
473.5	169.2	211.5	1521.7	247.7
478.5	169.3	211.7	1521.5	247.4
483.5	168.8	211.0	1522.1	247.3
488.5	168.8	211.1	1522.0	247.0
493.5	168.8	211.0	1522.1	246.7
498.5	168.7	210.9	1522.2	246.4
503.5	169.1	211.4	1521.7	246.0
508.5	168.8	211.1	1522.0	245.8
513.5	168.4	210.6	1522.4	250.3
518.5	168.5	210.7	1522.3	249.0
523.5	168.5	210.7	1522.3	249.6
528.5	168.3	210.4	1522.5	249.4
533.5	168.5	210.7	1522.3	249.0
538.5	168.5	210.7	1522.3	248.7
543.5	168.3	210.4	1522.5	248.4
548.5	168.3	210.4	1522.5	248.1
553.5	168.5	210.6	1522.4	247.7
558.5	168.2	210.3	1522.6	247.4
563.5	168.4	210.5	1522.4	247.1
568.5	91.4	114.3	1599.4	267.3
693.5	87.6	109.5	1603.3	264.0

TABLE 6.2-46 (Cont'd)

DOUBLE-ENDED PUMP SUCTION BREAK MAXIMUM SAFEGUARDS POST-REFLOOD
MASS AND ENERGY RELEASES - UNIT 2

Time (sec)	Break Path No. 1*		Break Path No. 2**	
	Flow (lbm/sec)	Energy (1000 BTU/sec)	Flow (lbm/sec)	Energy (1000 BTU/sec)
695.0	87.5	109.4	1520.7	353.2
780.6	87.5	109.4	1520.7	353.2
780.7	94.0	116.6	1514.2	349.5
785.0	93.9	116.5	1514.4	349.2
1254.2	93.9	116.5	1514.4	349.2
1254.3	84.0	96.6	1524.3	239.3
3600.0	64.2	73.9	1544.0	242.8
3600.1	53.6	61.6	1554.7	230.1
10000.0	39.0	44.8	1569.3	232.3
100000.0	20.8	24.0	1587.4	234.9
1000000.0	8.9	10.3	1599.3	236.7
10000000.0	2.8	3.2	1605.4	237.6

* mass and energy exiting the SG side of the break

** mass and energy exiting the pump side of the break

B/B-UFSAR

TABLE 6.2-47

DOUBLE-ENDED PUMP SUCTION BREAK MASS BALANCE MAXIMUM SAFEGUARDS - UNIT 2

Time (sec)		0.00	23.80	23.80	193.45	780.67	1254.25	3600.00
		Mass (1000 lbm)						
Initial	In RCS and ACC	760.82	760.82	760.82	760.82	760.82	760.82	760.82
Added Mass	Pumped Injection	0.00	0.00	0.00	276.18	1261.91	2023.55	5796.09
	Total Added	0.00	0.00	0.00	276.18	1261.91	2023.55	5796.09
TOTAL AVAILABLE		760.82	760.82	760.82	1037.00	2022.73	2784.37	6556.91
Distribution	Reactor Coolant	511.13	42.55	78.23	142.75	142.75	142.75	142.75
	Accumulator	249.69	209.32	173.64	0.00	0.00	0.00	0.00
	Total Contents	760.82	251.87	251.87	142.75	142.75	142.75	142.75
Effluent	Break Flow	0.00	518.20	518.20	891.84	1877.57	2639.15	6411.68
	ECCS Spill	0.00	00.00	0.00	0.00	0.00	0.00	0.00
	Total Effluent	0.00	518.20	518.20	891.84	1877.57	2639.15	6411.68
TOTAL ACCOUNTABLE		760.82	770.07	770.07	1034.60	2020.33	2781.90	6554.44

B/B-UFSAR

TABLE 6.2-48

DOUBLE-ENDED PUMP SUCTION BREAK ENERGY BALANCE
MAXIMUM SAFEGURARDS - UNIT 2

Time (sec)		0.00	23.80	23.80	193.45	780.67	1254.25	3600.00
		Energy (10 ⁶ BTU)						
Initial Energy	In RCS, ACC, SG	865.38	865.38	865.38	865.38	865.38	865.38	865.38
Added Energy	Pumped injection	0.00	0.00	0.00	24.30	119.31	232.04	790.37
	Decay Heat	0.00	8.17	8.17	29.41	83.57	120.02	263.31
	From Secondary	0.00	1.22	1.22	1.22	9.17	14.05	14.05
	Total Added	0.00	9.39	9.39	54.93	212.06	366.11	1067.73
TOTAL AVAILABLE		865.38	874.77	874.77	920.31	1077.44	1231.49	1933.11
Distribution	Reactor Coolant	308.94	10.27	13.81	38.06	38.06	38.06	38.06
	Accumulator	24.83	20.82	17.27	0.00	0.00	0.000	0.00
	Core Stored	23.98	12.69	12.69	4.91	4.71	4.48	3.33
	Primary Metal	153.18	145.93	145.93	117.29	81.48	67.88	51.65
	Secondary Metal	108.26	109.48	109.48	99.03	72.88	57.26	44.03
	Steam Generator	246.19	249.88	249.88	220.52	161.58	130.68	102.68
	Total Contents	865.38	549.07	549.07	479.80	358.70	298.35	239.75
	Effluent	Break Flow	0.00	325.93	325.93	431.33	709.56	913.95
	ECCS Spill	0.00	0.00	0.00	0.00	0.00	0.00	0.00
	Total Effluent	0.00	325.93	325.93	431.33	709.56	913.95	1679.40
TOTAL ACCOUNTABLE		865.38	875.00	875.00	911.13	1068.26	1212.30	1919.15

B/B-UFSAR

TABLE 6.2-49

LOCA MASS AND ENERGY RELEASE ANALYSIS CORE DECAY HEAT FRACTION

<u>Time (seconds)</u>	<u>Decay Heat Generation Rate (BTU/sec)</u>
1.00E+01	0.053876
1.50E+01	0.050401
2.00E+01	0.048018
4.00E+01	0.042401
6.00E+01	0.039244
8.00E+01	0.037065
1.00E+02	0.035466
1.50E+02	0.032724
2.00E+02	0.030936
4.00E+02	0.027078
6.00E+02	0.024931
8.00E+02	0.023389
1.00E+03	0.022156
1.50E+03	0.019921
2.00E+03	0.018315
4.00E+03	0.014781
6.00E+03	0.013040
8.00E+03	0.012000
1.00E+04	0.011262
1.50E+04	0.010097
2.00E+04	0.009350
4.00E+04	0.007778
6.00E+04	0.006958
8.00E+04	0.006424
1.00E+05	0.006021
1.50E+05	0.005323
4.00E+05	0.003770
6.00E+05	0.003201
8.00E+05	0.002834
1.00E+06	0.002580
1.00E+07	0.000808

Pages 6.2-162 through 6.2-177 has been intentionally deleted.

THIS PAGE WAS INTENTIONALLY DELETED

TABLE 6.2-50

MSLB MASS AND ENERGY RELEASES FOR UNIT 1

0.90 FT² SPLIT BREAK AT 30% POWER WITH MAIN STEAM ISOLATION VALVE
FAILURE - OFFSITE POWER AVAILABLE

<u>Time</u> <u>(sec)</u>	<u>Mass Rate*</u> <u>(lbm/sec)</u>	<u>Enthalpy</u> <u>(Btu/lbm)</u>
0.00	0.00	0.00
0.20	2124.67	1186.04
4.60	1992.16	1188.82
9.20	1895.86	1190.81
18.00	1777.25	1193.18
24.80	1811.74	1192.70
40.20	1663.95	1195.78
44.00	1473.60	1198.77
48.00	1331.00	1200.79
55.80	1141.17	1202.95
63.60	1013.13	1203.95
71.40	928.78	1204.32
79.20	878.44	1204.43
97.20	832.82	1204.47
169.00	804.06	1204.47
260.00	799.59	1204.46
262.40	778.19	1204.44
265.00	735.23	1204.33
267.40	666.48	1203.98
270.00	552.76	1202.78
273.80	363.15	1198.00
275.00	317.18	1196.04
276.20	279.18	1193.96
277.40	246.93	1191.79
278.80	215.43	1189.36
281.80	214.46	1189.41
288.80	210.63	1189.09
291.80	208.80	1188.95
295.00	208.64	1188.93
298.00	208.27	1188.91
301.20	207.78	1188.85
304.20	207.12	1188.81
307.40	206.80	1188.77
310.40	205.89	1188.69
313.40	205.19	1188.63
316.40	204.69	1188.58
319.40	204.21	1188.54
322.40	203.61	1188.49

TABLE 6.2-50 (Cont'd)

MSLB MASS AND ENERGY RELEASES FOR UNIT 1

0.90 FT² SPLIT BREAK AT 30% POWER WITH MAIN STEAM
ISOLATION VALVE FAILURE - OFFSITE POWER AVAILABLE

<u>Time</u> <u>(sec)</u>	<u>Mass</u> <u>Rate*</u> <u>(lbm/sec)</u>	<u>Enthalpy</u> <u>(Btu/lbm)</u>
325.40	202.92	1188.42
328.40	202.33	1188.37
331.40	201.53	1188.30
334.40	200.83	1188.23
337.20	199.78	1188.16
340.20	199.10	1188.09
343.20	198.29	1188.02
346.20	197.36	1187.94
349.20	196.39	1187.85
352.20	195.33	1187.75
355.20	194.13	1187.64
358.20	193.10	1187.54
361.00	191.58	1187.42
364.00	190.37	1187.30
367.00	189.07	1187.18
370.00	187.59	1187.03
373.00	186.04	1186.88
375.80	184.21	1186.72
378.80	182.40	1186.53
382.40	179.93	1186.26
404.80	161.77	1184.25
435.40	130.46	1179.99
451.80	118.01	1178.03
472.00	110.25	1176.73
489.00	107.67	1176.29
1800.40	106.48	1176.02
1803.60	85.06	1171.59
1808.60	58.38	1163.94
1813.80	34.58	1154.38
1815.00	27.80	1152.35
1816.00	20.72	1150.96
1816.40	17.50	1150.58
1816.60	15.51	1150.40
1816.80	0.00	0.00
1900.00	0.00	0.00

*Rate is total for all four loops

TABLE 6.2-50a

MSLB MASS AND ENERGY RELEASES FOR UNIT 1

1.0 FT² SPLIT BREAK AT 100% POWER WITH MAIN STEAM
ISOLATION VALVE FAILURE - LOSS OF OFFSITE POWER

<u>Time (sec)</u>	<u>Mass Rate* (lbm/sec)</u>	<u>Enthalpy (Btu/lbm)</u>
0.00	0.00	0.00
0.20	2261.07	1186.64
2.20	2184.46	1188.04
4.40	2118.88	1189.27
8.60	2020.73	1191.06
12.80	1951.33	1192.30
17.00	1902.20	1193.15
17.20	1985.98	1192.95
19.00	2081.52	1191.34
21.00	2163.00	1189.87
23.00	2214.41	1188.92
25.00	2235.82	1188.54
27.40	2217.85	1188.91
36.80	2035.90	1192.29
37.40	2033.35	1192.76
38.00	1969.07	1193.75
39.20	1868.17	1195.41
41.60	1699.22	1197.94
44.00	1557.81	1199.84
46.40	1437.41	1201.29
48.80	1333.71	1202.37
53.40	1170.23	1203.69
58.20	1034.94	1204.32
63.60	913.88	1204.47
67.60	841.08	1204.39
71.60	780.04	1204.20
75.60	728.30	1203.92
79.80	680.90	1203.55
87.80	604.00	1202.70
96.00	540.86	1201.72
104.00	490.81	1200.67
112.20	448.39	1199.57
120.20	414.08	1198.51
128.40	384.84	1197.48
136.40	360.98	1196.55
144.40	340.88	1195.68
160.60	308.83	1194.06
176.80	284.34	1192.60

TABLE 6.2-50a (Cont'd)

MSLB MASS AND ENERGY RELEASES FOR UNIT 1

1.0 FT² SPLIT BREAK AT 100% POWER WITH MAIN STEAM
ISOLATION VALVE FAILURE - LOSS OF OFFSITE POWER

<u>Time</u> <u>(sec)</u>	<u>Mass Rate*</u> <u>(lbm/sec)</u>	<u>Enthalpy</u> <u>(Btu/lbm)</u>
193.00	265.05	1191.35
209.20	249.91	1190.29
225.40	238.46	1189.45
257.60	222.19	1188.17
290.00	209.19	1187.10
322.20	198.09	1186.11
386.80	180.75	1184.36
419.00	174.32	1183.66
451.40	170.22	1183.19
516.00	166.49	1182.76
612.00	164.20	1182.48
794.60	162.88	1182.32
1155.00	153.61	1181.16
1569.80	151.39	1180.87
1656.20	139.34	1179.22
1684.80	132.35	1178.21
1728.00	117.31	1175.91
1742.40	113.58	1175.30
1771.20	109.17	1174.55
1800.00	107.16	1174.19
1801.00	107.86	1174.31
1801.80	107.39	1174.21
1802.80	105.59	1173.86
1804.60	99.92	1172.75
1807.60	87.12	1169.51
1807.80	84.96	1168.87
1808.20	79.42	1167.64
1809.40	66.73	1164.36
1810.20	59.87	1162.33
1811.20	52.00	1159.50
1812.80	40.10	1154.85
1813.40	34.96	1153.29
1813.80	31.19	1152.35
1814.20	27.05	1151.53
1814.60	22.38	1150.84
1814.80	19.64	1150.58
1815.00	16.71	1150.36
1815.20	0.00	0.00
1900.00	0.00	0.00

*Rate is total for all four loops

TABLE 6.2-50b

MSLB MASS AND ENERGY RELEASES FOR UNIT 2

0.83 FT² SPLIT BREAK AT 30% POWER WITH MAIN STEAM ISOLATION VALVE
FAILURE - OFFSITE POWER AVAILABLE

<u>Time (sec)</u>	<u>Mass Rate* (lbm/sec)</u>	<u>Enthalpy (Btu/lbm)</u>
0.00	0.00	0.00
0.20	1947.05	1186.38
5.20	1820.17	1189.26
10.20	1731.66	1191.23
20.00	1622.76	1193.56
27.00	1661.28	1192.92
43.00	1537.07	1195.48
48.20	1330.48	1199.23
52.40	1207.90	1201.06
56.60	1113.61	1202.28
60.80	1037.88	1203.09
69.20	926.94	1203.99
77.60	858.48	1204.32
86.00	820.37	1204.41
100.80	789.84	1204.46
129.80	771.32	1204.47
284.40	755.47	1204.47
287.20	725.66	1204.45
290.20	666.40	1204.28
293.20	574.59	1203.62
299.00	365.81	1199.24
300.40	323.36	1197.55
302.00	281.91	1195.50
303.40	251.51	1193.60
305.00	222.77	1191.45
309.80	197.70	1189.42
313.40	194.95	1189.18
316.80	194.25	1189.10
320.00	193.58	1189.04
323.20	193.26	1189.01
326.40	192.87	1188.97
329.60	192.36	1188.93
332.80	191.81	1188.87
336.00	191.10	1188.80
339.00	190.54	1188.76
342.00	189.90	1188.70
345.00	189.12	1188.63
348.00	188.51	1188.57

TABLE 6.2-50b (Cont'd)

MSLB MASS AND ENERGY RELEASES FOR UNIT 2

0.83 FT² SPLIT BREAK AT 30% POWER WITH MAIN STEAM ISOLATION VALVE
FAILURE - OFFSITE POWER AVAILABLE

<u>Time</u> <u>(sec)</u>	<u>Mass Rate*</u> <u>(lbm/sec)</u>	<u>Enthalpy</u> <u>(Btu/lbm)</u>
351.00	187.98	1188.52
354.00	187.33	1188.45
357.00	186.63	1188.39
360.00	185.83	1188.31
363.00	185.03	1188.23
366.00	184.33	1188.16
368.80	183.20	1188.06
371.80	182.27	1187.97
374.80	181.33	1187.87
377.60	180.18	1187.76
380.60	179.11	1187.65
383.80	177.76	1187.50
407.80	164.25	1186.08
446.80	131.49	1181.76
466.40	118.06	1179.63
485.80	110.93	1178.41
505.40	107.88	1177.87
737.60	106.08	1177.54
1800.40	106.58	1177.59
1801.20	103.77	1177.01
1803.60	89.30	1174.15
1809.80	58.09	1165.35
1812.40	46.75	1161.23
1816.20	31.86	1154.38
1817.40	25.93	1152.44
1818.00	22.53	1151.61
1819.00	15.89	1150.55
1819.20	13.97	1150.38
1819.40	0.00	0.00
1900.00	0.00	0.00

*Rate is total for all four loops

TABLE 6.2-50c

MSLB MASS AND ENERGY RELEASES FOR UNIT 2

1.0 FT² SMALL DOUBLE-ENDED RUPTURE AT 100% POWER WITH MAIN STEAM ISOLATION VALVE FAILURE - LOSS OF OFFSITE POWER

<u>Time</u> <u>(sec)</u>	<u>Mass Rate*</u> <u>(lbm/sec)</u>	<u>Enthalpy</u> <u>(Btu/lbm)</u>
0.00	0.00	0.00
0.20	4328.49	1189.75
0.40	4248.73	1190.23
1.40	4027.57	1191.89
2.60	3847.53	1193.33
2.80	3947.19	1193.24
6.20	3933.13	1193.11
9.00	3885.43	1194.27
10.80	3628.48	1194.74
19.60	2283.76	1197.90
25.40	1448.41	1200.97
28.40	1035.55	1203.92
28.80	986.37	1204.42
32.00	911.06	1204.47
35.60	838.71	1204.39
39.20	778.05	1204.19
42.80	726.16	1203.90
46.40	680.10	1203.54
53.60	600.41	1202.65
60.80	536.05	1201.63
67.80	484.56	1200.52
75.00	440.42	1199.33
82.20	403.84	1198.16
89.40	373.53	1197.05
96.60	348.46	1196.02
103.80	327.45	1195.03
111.00	309.90	1194.11
118.20	295.09	1193.26
132.40	272.04	1191.81
146.80	254.53	1190.62
161.20	240.82	1189.62
175.40	230.19	1188.81
189.80	221.83	1188.15
204.20	215.36	1187.62
261.80	195.11	1185.82
319.20	177.43	1184.01
348.00	170.39	1183.21
376.60	166.26	1182.73

TABLE 6.2-50c (Cont'd)

MSLB MASS AND ENERGY RELEASES FOR UNIT 2

1.0 FT² SMALL DOUBLE-ENDED RUPTURE AT 100% POWER WITH MAIN
STEAM ISOLATION VALVE FAILURE - LOSS OF OFFSITE POWER

<u>Time (sec)</u>	<u>Mass Rate* (lbm/sec)</u>	<u>Enthalpy (Btu/lbm)</u>
434.00	163.05	1182.34
634.00	159.78	1181.94
801.20	154.55	1181.28
867.60	144.22	1179.91
893.60	138.14	1179.05
945.60	118.59	1176.12
958.60	114.60	1175.47
971.60	111.55	1174.96
997.60	107.90	1174.32
1023.60	106.22	1174.03
1086.80	105.57	1173.91
1151.00	106.23	1174.03
1800.00	106.07	1174.00
1801.00	107.06	1174.17
1802.00	106.57	1174.06
1803.00	104.75	1173.71
1804.00	102.01	1173.17
1807.40	89.24	1170.22
1810.20	75.51	1166.80
1811.00	68.06	1164.74
1812.20	58.33	1161.84
1814.40	42.80	1155.83
1815.00	38.27	1154.27
1815.80	31.43	1152.42
1816.40	25.50	1151.28
1816.60	23.27	1150.96
1816.80	20.82	1150.67
1817.00	17.90	1150.43
1817.20	0.00	0.00
1900.00	0.00	0.00

*Rate is total for all four loops

TABLE 6.2-51

UNIT 1 LBLOCA REFERENCE TRANSIENT MASS & ENERGY RELEASES
FOR MINIMUM ECCS LOCA CONTAINMENT PRESSURE

TIME(sec)	Vessel Side Mass Flow (lbm/sec)	Vessel Side Energy Flow (BTU/sec)	RCP Side Mass Flow (lbm/sec)	RCP Side Energy Flow (BTU/sec)
0.0167	-9.3	0	9574	5299111.8
0.5167	53280.8	29318181.5	26325.4	14479145
1.0167	49743.2	27363420.3	25669.2	14265989.2
2.0167	37558.3	20675672.6	22577.9	12989816.3
4.0167	27578.4	15336667.6	11205	7221814.4
6.0167	23950.5	13593964.7	7167.5	5256118.6
8.0167	20595.1	12005111.8	8133	6783089.5
10.0167	17018.1	10322889	5490.3	4778205.6
15.0167	7265.4	5678442.3	3519.4	3217683.4
20.0167	7194.8	2645643	649.3	810071.7
25.0167	5247.6	1153174.7	102.6	126038.5
30.0167	-173.2	0	-6	0
35.0168	-101	0	9.4	12117.2
40.0168	12.3	10795	68.5	87877.5
45.0167	86.8	15675.6	49.5	63518.6
50.0167	1266.1	177145.6	94.1	119871.3
60.0167	2170.1	529968.3	35	44500.7
70.0171	341.1	220966.2	70.5	89151.2
80.0168	93.6	86380.7	49.8	63791.4
90.0176	66.7	58606.3	44.7	57283.8
100.0174	109.7	104101.7	56.6	72322.1
150.0171	366	162350.4	62.4	79106.2
200.0176	490.7	179556	61	76724.2
250.0175	735.9	201291.4	49.4	62216.7
300.0173	593.9	183995.3	47	58927.1
350.0168	176.3	111498.4	46.5	57928.7
400.0173	529.1	150696.5	47.9	59466.2
450.0172	408.8	158980.7	45.8	56890.2
500.0176	198.8	127041.8	46.5	57223.9

B/B-UFSAR

TABLE 6.2-52

UNIT 2 LBLOCA REFERENCE TRANSIENT MASS & ENERGY RELEASES
FOR MINIMUM ECCS LOCA CONTAINMENT PRESSURE

TIME (SEC)	Vessel Side Mass Flow (lbm/sec)	Vessel Side Energy Flow (BTU/sec)	RCP Side Mass Flow (lbm/sec)	RCP Side Energy Flow (BTU/sec)
0.0043	-9.3	0	9572	5297228.4
0.505	54561.8	29968657	26094	14349465.6
1.005	49727	27332157.1	25336.6	14142759.8
2.005	37203.9	20465436.2	19824.8	11641241.4
4.005	26043.2	14482124.1	9959.7	6806783.4
6.005	21570	12359487.8	6627.6	5440866.5
8.005	17919.7	10650160.9	5764.8	4856694.6
10.005	13591.3	8389644.6	5187.2	4263591.2
15.005	8018.8	4168871.2	2079.8	2039772.1
20.005	7023.3	1843057.6	449.6	543737.4
25.005	1043	209012.4	91.2	115039.6
30.0048	-11.8	0	46.4	59536.3
35.0047	-25.3	0	25.1	32346.8
40.0044	13.4	14132	51.3	65843.6
45.0047	-21.6	0	51	65587.8
50.0044	1966	261201.1	77.4	98766.1
60.0048	1183.8	508743.5	143.3	177691.9
70.005	2247.4	515101.7	84.3	106386.4
80.0045	113	102292.9	48.5	62130.7
90.0045	91.5	85557.5	47.1	60278.2
100.0045	95	89326.2	48.8	62388.9
150.0049	357.1	161441.8	59.2	74829.1
200.0045	927.4	260685.7	60.8	75906.3
250.005	187.7	153151.4	54.5	68136.7
300.0044	144.7	51529.2	41.8	52671.4
350.0048	138.6	100163.8	44.1	54614
400.0049	451.7	150834.6	49.7	61082.9
450.0044	262.3	130088.4	50.2	61601.6
500.0045	654.6	203118.4	75.7	80968.6

TABLE 6.2-53

BROKEN LOOP SAFETY INJECTION AND ACCUMULATOR INJECTION SPILL TO
CONTAINMENT FOR MINIMUM ECCS LOCA CONTAINMENT PRESSURE

TIME (sec)	MASS FLOW (lb/sec)	ENERGY ¹ (Btu/sec)	ENTHALPY (Btu/lb)
0	2,420	72,648	30.02
27	2,420	72,648	30.02
27.01	312.2	8	0.026
End	312.2	8	0.026

¹ Energy equals the mass flow times the enthalpy.

TABLE 6.2-54

ACTIVE HEAT SINK DATAFOR MINIMUM ECCS LOCA CONTAINMENT PRESSURE

I Containment Spray System Parameters	
A. Maximum spray system delivered flow, total	9255 gpm
B. Number of pumps operating	2
C. Minimum spray temperature	32 °F
D. Fastest post-LOCA initiation of spray system with or without offsite power loss at start of LOCA	0 sec
II Containment Atmosphere Recirculation Fan Coolers	
A. Maximum number of fan coolers operating	4
B. Fastest post-LOCA initiation with or without offsite power loss at start of LOCA	0 sec
C. Minimum service water temperature	32 °F
D. Performance data (1 fan cooler)*	

<u>Containment Temperature (°F)</u>	<u>Heat Removal (BTU/sec)</u>
50	1220
100	4033
110	5197
120	6596
130	8264
160	15092
190	24437
220	34695
250	44360
271	50626

* service water temperature = 32°F

TABLE 6.2-55

PASSIVE HEAT SINK DATA FOR MINIMUM
POST LOCA CONTAINMENT PRESSURE

A. Heat Sink Description

Slab Number	Description	Slab Material	Material Thickness (ft)	Surface Area (ft ²)
1.	Structural Steel	Carbon Steel	0.025	283,617.0
2.	Structural Steel	Carbon Steel	0.1325	1154.7
3.	Structural Steel	Carbon Steel	0.00714	29,719.0
4.	Structural Steel	Carbon Steel	0.00390	20,411.0
5.	Structural Steel	Carbon Steel	0.20833	892.5
6.	Structural Steel	Carbon Steel	0.23958	782.25
7.	Structural Steel	Carbon Steel	0.1250	1107.75
8.	Structural Steel	Carbon Steel	0.1040	906.09
9.	Structural Steel	Carbon Steel	0.04167	42,144.9
10.	Structural Steel	Carbon Steel	0.1040	40,000.0
11.	Structural Steel	Carbon Steel	0.1667	531.82
12.	Structural Steel	Carbon Steel	0.1875	131.67
13.	Internal Concrete	Concrete	1.0	101,391.04
14.	Internal Concrete	Concrete	1.0	14,766.67
15.	Containment Floor	Steel	0.03362	828.13
	Containment Floor	Concrete	1.0	
16.	Foundation and Sump	Steel	0.02292	1850.2
	Foundation and Sump	Concrete	1.0	
17.	Foundation and Sump	Steel	0.01563	10,134.8
	Foundation and Sump	Concrete	1.0	

TABLE 6.2-55 (Cont'd)

PASSIVE HEAT SINK DATA FOR MINIMUM
POST LOCA CONTAINMENT PRESSURE (cont.)

Slab Number	Description	Slab Material	Material Thickness (ft)	Surface Area (ft ²)
18.	Foundation and Sump	Steel	0.04899	23,489.55
	Foundation and Sump	Concrete	1.0	
19.	Foundation and Sump	Steel	0.15276	3022.63
	Foundation and Sump	Concrete	1.0	
20.	Foundation and Sump	Steel	0.02083	115,872.75
	Foundation and Sump	Concrete	4.50	
21.	Misc. Internal Structures	Steel	0.00390	35,400.0
22.	Misc. Internal Structures	Steel	0.00390	714.0
23.	Misc. Internal Structures	Steel	0.01042	30,000.0

TABLE 6.2-55 (Cont'd)

PASSIVE HEAT SINK DATA FOR MINIMUM
POST LOCA CONTAINMENT PRESSURE (cont.)

B. Thermophysical Properties

	Density lb/cu.ft	Specific Heat Btu/lb °F	Thermal Conductivity Btu/hr-ft °F
Concrete	145	0.156	0.92
Steel	490	0.12	27.0
Carbon Steel	490	0.12	27.0

TABLE 6.2-56

REACTOR CONTAINMENT FAN COOLER DESIGN CHARACTERISTICS(EACH UNIT)

	NORMAL MODE OPERATION	ACCIDENT MODE OPERATION
1. <u>Fan</u>		
Number of fans	1	
Fan type	Vane-axial	
Nominal speed (r/min)	1770	1170
Capacity (ft ³ /min)	94,000	59,000*
Containment atmosphere pressure (psig)	0	50
Containment atmosphere temperature (°F)	120	271
Air inlet temperature (°F)	48.0	264
Containment atmosphere density (lb/ft ³)	0.0667	0.189
Air inlet density (lb/ft ³)	0.0754	0.189
2. <u>Motor</u>		
Number	1	
Enclosure	TEAO	
Type	480 V, 3 ϕ , 60 Hz, two-speed	
Bearing monitors	Vibration and temperature	
Winding monitors	Iron-Constantan Thermocouples	
Service factor	1.0	

* Coil manufacturer specified value. Actual value required is based on required containment heat removal. For accident mode operation, a flow of 54,000 CFM has been shown by the safety analysis to be adequate to maintain containment integrity.

TABLE 6.2-56 (Cont'd)

	NORMAL MODE OPERATION	ACCIDENT MODE OPERATION
Speed (r/min)	1800	1200
Horsepower	150	100
3. <u>Cooling Coil Assembly</u>		
A. <u>Essential Service Water Section</u>		
Number of coil sections	10	
Net face area of all coil sections (ft ²)	238	
Type	Helical finned	
Tube material	Copper Nickel 90/10	
Fin material	Copper	
Maximum fins per inch	8	
Nominal tube thickness (in.)	0.049	
Nominal fin thickness (in.)	0.010	
Tube nominal OD (in.)	5/8	
Nominal tube length (in.)	120	
Coil frame material	Galv. steel	
Drain pan material	Stainless steel	
Heat removal (Btu/hr)	1.97 x 10 ⁶	132 x 10 ^{6*}
Steam-air flow entering coil (ft ³ /min)	106,700	73,700
Steam-air flow leaving coil (ft ³ /min)	103,200	59,000
Steam-air inlet temperature (°F)	120	271

* Original manufacturer specified value. Actual required value established by the safety analysis is 129 x 10⁶ Btu/hr/RCFC Unit based on the estimated heat released in the containment of 143 x 10⁶ Btu/second.

TABLE 6.2-56 (Cont'd)

	NORMAL MODE OPERATION	ACCIDENT MODE OPERATION
Steam-air outlet temperature (°F)	101	263
Total pressure (psig)	0	50
Steam-air density entering coil (lb/ft ³)	0.0657	0.1795
Steam-air density leaving coil (lb/ft ³)	0.068	0.1872
Relative humidity entering coil (%)	11%	100%
Relative humidity leaving coil (%)	20%	100%
Cooling water flow (gal/min)	2660	2660
Cooling water inlet temperature (°F)	100	100
Cooling water outlet temperature (°F)	101.0	203
Coil tube side fouling factor	0.0015	0.0015

B. Chilled Water Section

Number of coil sections	10
Net face area for all coil sections (ft ²)	238
Type	Helical finned
Tube material	Copper-Nickel 90/10
Fin material	Copper
Fins per inch	8
Nominal tube thickness (in.)	0.049
Nominal fin thickness (in.)	0.010
Tube nominal OD (in.)	5/8
Nominal tube length (in.) Coil frame material	120 Galv. steel

TABLE 6.2-56 (Cont'd)

	NORMAL MODE OPERATION	ACCIDENT MODE OPERATION
Drain pan material	Stainless steel	
Heat removal (Btu/hr)	6.1×10^6	0
Steam-air flow leaving coil (ft ³ /min)	103,900	59,000
Steam-air inlet temperature (°F)	101	263
Steam-air outlet temperature (°F)	49	263
Total pressure (psig)	0	50
Steam-air inlet density (lb/ft ³)	0.068	0.1872
Steam-air outlet density (lb/ft ³)	0.0748	0.1872
Cooling chilled water flow (gal/min)	1500	0
Cooling chilled water inlet temperature (°F)	42	--
Cooling chilled water outlet temperature (°F)	50	--

TABLE 6.2-57

SINGLE ACTIVE FAILURE ANALYSIS
REACTOR CONTAINMENT FAN COOLERS

COMPONENT	MALFUNCTION	COMMENTS
Fan motors	Failure to start	Redundant system is provided. Separate power supplies for each system.
Fan	Unsatisfactory performance	Redundant system is provided. Separate power supplies for each system.
Essential service water cooling coils	None	Passive component, active failure not credible.
Essential service water cooling coils piping and valves	Failure of valves to open	Not credible, valves will fail open on loss of electric or air supply to the valve operator to assure ESW flow. A redundant system is provided.
Enclosure and ductwork	None	Passive component, active failure not credible.
Backdraft damper	Failure to close	If failure of fan results, redundant system is provided with separate power supplies for each system.

B/B-UFSAR

TABLE 6.2-58

CONTAINMENT ISOLATION PROVISIONS

ISOLATION VALVE NUMBER	GDC REQUIREMENT MET	PENETRATION NUMBER	FLUID	LINE SIZE (in.)	ESSENTIAL*	REFERENCE DRAWING	VALVE LOCATION (INSIDE OR OUTSIDE CONTAINMENT)	TYPE C LEAK TEST (YES OR NO)	DISTANCE TO OUTERMOST ISOLATION VALVE (ft)	VALVE TYPE
CVCS										
1CV8100	55	28	RC	2	YES	M-64-2	Outside	NO	2.6	Globe
1CV8112	55	28	RC	2	YES	M-64-2	Inside	NO	N/A	Globe
1CV8355C	55	53	RC	2		M-64-2	Outside	NO	4.0	Globe
1CV8368C	55	53	RC	2		M-64-2	Inside	NO	N/A	Check
1CV8355D	55	33	RC	2		M-64-2	Outside	NO	4.0	Globe
1CV8368D	55	33	RC	2		M-64-2	Inside	NO	N/A	Check
1CV8355A	55	33	RC	2		M-64-1	Outside	NO	4.0	Globe
1CV8368A	55	33	RC	2		M-64-1	Inside	NO	N/A	Check
1CV8355B	55	53	RC	2		M-64-1	Outside	NO	4.0	Globe
1CV8368B	55	53	RC	2		M-64-1	Inside	NO	N/A	Check
1CV8105	57	71	RC	3	YES	M-64-3	Outside	NO	2.9	Gate
1CV8106	57	71	RC	3	YES	M-64-3	Outside	NO	4.75	Gate
1CV8346	55	37	RC	2		M-64-3	Outside	NO	3.2	Globe
1CV8348	55	37	RC	2		M-64-3	Inside	NO	N/A	Check
1CV8152	55	41	RC	3	YES	M-64-5	Outside	YES (Bwd) NO (Byr)	2.9	Globe
1CV8160	55	41	RC	3	YES	M-64-5	Inside	YES (Bwd) NO (Byr)	N/A	Globe
1CV8113	55	28	RC	3/4		M-64-2	Inside	NO	N/A	Check
Chilled Water										
1W0020A	56	5	Water	10	YES	M-118-5	Outside	YES	3.0	Gate
1W0006A	56	6	Water	10	YES	M-118-5	Outside	YES	3.0	Gate
1W0020B	56	8	Water	10	YES	M-118-5	Outside	YES	3.3	Gate
1W0006B	56	10	Water	10	YES	M-118-5	Outside	YES	3.3	Gate
1W0007A	56	6	Water	10	YES	M-118-5	Inside	YES	N/A	Check
1W0007B	56	10	Water	10	YES	M-118-5	Inside	YES	N/A	Check
1W0056A	56	5	Water	10	YES	M-118-5	Inside	YES	N/A	Gate
1W0056B	56	8	Water	10	YES	M-118-5	Inside	YES	N/A	Gate

B/B-UFSAR

TABLE 6.2-58 (Cont'd)

CONTAINMENT ISOLATION PROVISIONS

ISOLATION VALVE NUMBER	GDC REQUIREMENT MET	PENETRATION NUMBER	FLUID	LINE SIZE (in.)	ESSENTIAL*	REFERENCE DRAWING	VALVE LOCATION (INSIDE OR OUTSIDE CONTAINMENT)	TYPE C LEAK TEST (YES OR NO)	DISTANCE TO OUTERMOST ISOLATION VALVE (ft)	VALVE TYPE
1W0079A (Byron)	56	5	Water	3/4		M-118-5	Inside	YES	N/A	Relief
1W0079B (Byron)	56	8	Water	3/4		M-118-5	Inside	YES	N/A	Relief
1W0091A (Braidwood)	56	5	Water	3/4		M-118-5	Inside	YES	N/A	Relief
1W0091B (Braidwood)	56	8	Water	3/4		M-118-5	Inside	YES	N/A	Relief

B/B-UFSAR

TABLE 6.2-58 (Cont'd)

ISOLATION VALVE NUMBER (Cont'd)	GDC REQUIREMENT MET	VALVE OPERATOR	NORMAL POSITION	SHUTDOWN POSITION	POST-ACCIDENT POSITION	POWER FAILURE POSITION	CLOSURE TIME** (sec)	ISOLATION SIGNALS	PRIMARY MODE OF ACTION	SECONDARY MODE OF ACTION	POWER SOURCE	ISOLATION VALVE CONFIGURATION
CVCS												
1CV8100	55	MO	Open	Open	Closed	As Is	10	T	A	RM	1E	1,5
1CV8112	55	MO	Open	Open	Closed	As Is	10	T	A	RM	1E	1
1CV8355C	55	MO	Open	Open	Open	As Is	N/*	N/A	RM	M	1E	5
1CV8368C	55	N/A	N/A	N/A	N/A	N/A	N/A	N/A	N/A	N/A	N/A	5
1CV8355D	55	MO	Open	Open	Open	As Is	N/*	N/A	RM	M	1E	5
1CV8368D	55	N/A	N/A	N/A	N/A	N/A	N/A	N/A	N/A	N/A	N/A	5
1CV8355A	55	MO	Open	Open	Open	As Is	N/*	N/A	RM	M	1E	5
1CV8368A	55	N/A	N/A	N/A	N/A	N/A	N/A	N/A	N/A	N/A	N/A	5
1CV8355B	55	MO	Open	Open	Open	As Is	N/*	N/A	RM	M	1E	5
1CV8368B	55	N/A	N/A	N/A	N/A	N/A	N/A	N/A	N/A	N/A	N/A	5
1CV8105	57	MO	Open	Open	Closed	As Is	10	S	A	RM	1E	8
1CV8106	57	MO	Open	Open	Closed	As Is	10	S	A	RM	1E	8
1CV8346	55	M	Closed	Closed	Closed	N/A	N/A	N/A	M	M	N/A	7
1CV8348	55	N/A	N/A	N/A	N/A	N/A	N/A	N/A	N/A	N/A	N/A	7
1CV8152	55	AO/S	Open	Open	Open	Closed	10	T	A	RM	1E	2
1CV8160	55	AO/S	Open	Open	Open	Closed	10	T	A	RM	1E	2
1CV8113	55	N/A	N/A	N/A	N/A	N/A	N/A	N/A	N/A	N/A	N/A	5
Chilled Water												
1W0020A	56	MO	Open	Open	Closed	As Is	50	T	A	RM	1E	1
1W0006A	56	MO	Open	Open	Closed	As Is	50	T	A	RM	1E	5
1W0020B	56	MO	Open	Open	Closed	As Is	50	T	A	RM	1E	1
1W0006B	56	MO	Open	Open	Closed	As Is	50	T	A	RM	1E	5
1W0007A	56	N/A	N/A	N/A	N/A	N/A	N/A	N/A	N/A	N/A	N/A	5
1W0007B	56	N/A	N/A	N/A	N/A	N/A	N/A	N/A	N/A	N/A	N/A	5
1W0056A	56	MO	Open	Open	Closed	As Is	50	T	A	RM	1E	1
1W0056B	56	MO	Open	Open	Closed	AS Is	50	T	A	RM	1E	1

B/B-UFSAR

TABLE 6.2-58 (Cont'd)

ISOLATION VALVE NUMBER (Cont'd)	GDC REQUIRE-MENT MET	VALVE OPER-ATOR	NORMAL POSITION	SHUTDOWN POSITION	POST-ACCIDENT POSITION	POWER FAILURE POSITION	CLOSURE TIME** (sec)	ISOLA-TION SIGNALS	PRIMARY MODE OF ACTUA-TION	SECOND-ARY MODE OF ACTUA-TION	POWER SOURCE	ISOLATION VALVE CONFIGU-RATION
1W0079A (Byron)	56	N/A	Closed	Closed	Closed	N/A	N/A	N/A	N/A	N/A	N/A	1A
1W0079B (Byron)	56	N/A	Closed	Closed	Closed	N/A	N/A	N/A	N/A	N/A	N/A	1A
1W0091A (Braidwood)	56	N/A	Closed	Closed	Closed	N/A	N/A	N/A	N/A	N/A	N/A	1A
1W0091B (Braidwood)	56	N/A	Closed	Closed	Closed	N/A	N/A	N/A	N/A	N/A	N/A	1A

B/B-UFSAR

TABLE 6.2-58 (Cont'd)

ISOLATION VALVE NUMBER	GDC REQUIRE-MENT MET	PENETRA-TION NUMBER	FLUID	LINE SIZE (in.)	ESSEN-TIAL*	REFERENCE DRAWING	VALVE LOCA-TION (INSIDE OR OUTSIDE CONTAINMENT)	TYPE C LEAK TEST (YES OR NO)	DISTANCE TO OUTERMOST ISOLATION VALVE (ft)	VALVE TYPE
Component Cooling										
1CC9414	56	21	CCW	6	YES	M-66-1A	Outside	YES	2.9	Gate
1CC9416	56	21	CCW	6	YES	M-66-1A	Inside	YES	N/A	Gate
1CC9534	56	21	CCW	3/4		M-66-1A	Inside	YES	N/A	Check
1CC9437B	57	22	CCW	3	YES	M-66-1A	Outside	NO	3.1	Globe
1CC685	56	24	CCW	4††	YES	M-66-1A	Outside	YES	3.1	Gate
1CC9438	56	24	CCW	4	YES	M-66-1A	Inside	YES	N/A	Gate
1CC9518	56	24	CCW	3/4	YES	M-66-1A	Inside	YES	N/A	Check
1CC9486	56	25	CCW	6		M-66-1A	Inside	YES	N/A	Check
1CC9413A	56	25	CCW	6	YES	M-66-1A	Outside	YES	4.9	Gate
1CC9437A	57	48	CCW	3	YES	M-66-1A	Outside	NO	6.8	Globe
Containment Purge										
1VQ005A	56	94	Air	8	YES	M-105-1	Inside	YES	N/A	But. Fly
1VQ005B	56	94	Air	8	YES	M-105-1	Outside	YES	6.0	But. Fly
1VQ003	56	94	Air	8	YES	M-105-1	Outside	YES	9.0	But. Fly
1VQ002A	56	95	Air	48		M-105-1	Inside	YES	N/A	But. Fly
1VQ002B	56	95	Air	48		M-105-1	Outside	YES	2.9	But. Fly
1VQ004A	56	96	Air	8	YES	M-105-1	Inside	YES	N/A	But. Fly
1VQ004B	56	96	Air	8	YES	M-105-1	Outside	YES	2.0	But. Fly
1VQ001A	56	97	Air	48		M-105-1	Inside	YES	N/A	But. Fly
1VQ001B	56	97	Air	48		M-105-1	Outside	YES	2.9	But. Fly
1VQ005C	56	94	Air	8	YES	M-105-1	Outside	YES	3.5	But. Fly
Containment Spray										
1CS007A	56	1	NaOH+BW	10	YES	M-46-1	Outside	YES (Bwd) NO (Byr)	3.3	Gate
1CS008A	56	1	NaOH+BW	10		M-46-1	Inside	YES (Bwd) NO (Byr)	N/A	Check
1CS007B	56	16	NaOH+BW	10	YES	M-46-1	Outside	YES (Bwd) NO (Byr)	3.8	Gate
1CS008B	56	16	NaOH+BW	10		M-46-1	Inside	YES (Bwd) NO (Byr)	N/A	Check

B/B-UFSAR

TABLE 6.2-58 (Cont'd)

ISOLATION VALVE NUMBER (Cont'd)	GDC REQUIREMENT	VALVE OPERATOR	NORMAL POSITION	SHUTDOWN POSITION	POST-ACCIDENT POSITION	POWER FAILURE POSITION	CLOSURE TIME** (sec)	ISOLATION SIGNALS	PRIMARY MODE OF ACTION	SECONDARY MODE OF ACTION	POWER SOURCE	ISOLATION VALVE CONFIGURATION
Component Cooling												
1CC9414	56	MO	Open	Open	Closed	As Is	10	P	A	RM	1E	1,5
1CC9416	56	MO	Open	Open	Closed	As Is	10	P	A	RM	1E	1
1CC9534	56	N/A	N/A	N/A	N/A	N/A	N/A	N/A	N/A	N/A	N/A	5
1CC9437B	57	AO/S	Closed	Closed	Closed	Closed	10	T	A	RM	1E	11
1CC685	56	MO	Open	Open	Closed	As Is	10	P	A	RM	1E	1,5
1CC9438	56	MO	Open	Open	Closed	As Is	10	P	A	RM	1E	1
1CC9518	56	N/A	N/A	N/A	N/A	N/A	N/A	N/A	N/A	N/A	N/A	5
1CC9486	56	N/A	N/A	N/A	N/A	N/A	N/A	N/A	N/A	N/A	N/A	5
1CC9413A	56	MO	Open	Open	Closed	As Is	10	P	A	RM	1E	5
1CC9437A	57	AO/S	Closed	Closed	Closed	Closed	10	T	A	RM	1E	11
Containment Purge												
1VQ005A	56	AO/S	Closed	****	Closed	Closed	5	T2	A	RM	1E	2
1VQ005B	56	AO/S	Closed	****	Closed	Closed	5	T2	A	RM	1E	2
1VQ003	56	AO/S	Closed	Closed	Closed	Closed	5	T2	A	RM	1E	2
1VQ002A (Byron)	56	HO	Closed	****	Closed	Closed	N/A	T2	A	RM	1E	1
1VQ002B (Byron)	56	HO	Closed	****	Closed	Closed	N/A	T2	A	RM	1E	1
1VQ002A (Braidwood)	56	HO	Closed	Closed	Closed	Closed	N/A	T2	N/A	N/A	1E	1
1VQ002B (Braidwood)	56	HO	Closed	Closed	Closed	Closed	N/A	T2	N/A	N/A	1E	1
1VQ004A	56	AO/S	Closed	****	Closed	Closed	5	T2	A	RM	1E	2
1VQ004B	56	AO/S	Closed	****	Closed	Closed	5	T2	A	RM	1E	2
1VQ001A (Byron)	56	HO	Closed	****	Closed	Closed	N/A	T2	A	RM	1E	1
1VQ001B (Byron)	56	HO	Closed	****	Closed	Closed	N/A	T2	A	RM	1E	1
1VQ001A (Braidwood)	56	HO	Closed	Closed	Closed	Closed	N/A	T2	N/A	N/A	1E	1
1VQ001B (Braidwood)	56	HO	Closed	Closed	Closed	Closed	N/A	T2	N/A	N/A	1E	1
1VQ005C	56	AO/S	Closed	****	Closed	Closed	5	T2	A	RM	1E	2
Containment Spray												
1CS007A	56	MO	Closed	Closed	Closed	As Is	30	T1	A	RM	1E	5
1CS008A	56	N/A	N/A	N/A	N/A	N/A	N/A	N/A	N/A	N/A	N/A	5
1CS007B	56	MO	Closed	Closed	Closed	As Is	30	T1	A	RM	1E	5
1CS008B	56	N/A	N/A	N/A	N/A	N/A	N/A	N/A	N/A	N/A	N/A	5

B/B-UFSAR

TABLE 6.2-58 (Cont'd)

ISOLATION VALVE NUMBER	GDC REQUIREMENT MET	PENETRATION NUMBER	FLUID	LINE SIZE (in.)	ESSENTIAL*	REFERENCE DRAWING	VALVE LOCATION (INSIDE OR OUTSIDE CONTAINMENT)	TYPE C LEAK TEST (YES OR NO)	DISTANCE TO OUTERMOST ISOLATION VALVE (ft)	VALVE TYPE
Essential Service										
Water										
1SX016B	57	7	Water	16	YES	M-42-5	Outside	NO	3.2	But. Fly
1SX027B	57	9	Water	16	YES	M-42-5	Outside	NO	3.2	But. Fly
1SX027A	57	14	Water	16	YES	M-42-5	Outside	NO	2.8	But. Fly
1SX016A	57	15	Water	16	YES	M-42-5	Outside	NO	2.8	But. Fly
Fire Protection										
1FP010	56	34	Water	4	YES	M-52-1	Outside	NO	3.3	Globe
1FP345	56	34	Water	4	YES	M-52-1	Inside	NO	N/A	Check
Instrument										
Air										
1IA065	56	39	Air	3	YES	M-55-2	Outside	YES	3.3	Globe
1IA066	56	39	Air	3	YES	M-55-2	Inside	YES	N/A	Globe
1IA091	56	39	Air	3/4	YES	M-55-2	Inside	YES	N/A	Check
Instrument Penetration										
1VQ016	56	I3	Air	1/2		M-105-3	Inside	YES	N/A	Globe
1VQ017	56	I3	Air	1/2		M-105-3	Inside	YES	N/A	Globe
1VQ018	56	I3	Air	1/2		M-105-3	Outside	YES	MIN.	Globe
1VQ019	56	I3	Air	1/2		M-105-3	Outside	YES	MIN.	Globe
		I1	Silicone Oil			M-2046-2,4				
		I2	Silicone Oil			M-2046-2,4				
		I3	Silicone Oil			M-2046-2,4				
		I4	Silicone Oil			M-2046-2,4				
1RY075	57	I5	Water	1/2		M-2060-6	Outside	YES	1.0	Globe
		19	Water			M-2060-17,18				

B/B-UFSAR

TABLE 6.2-58 (Cont'd)

ISOLATION VALVE NUMBER	GDC REQUIREMENT MET	PENETRATION NUMBER	FLUID	LINE SIZE (in.)	ESSENTIAL*	REFERENCE DRAWING	VALVE LOCATION (INSIDE OR OUTSIDE CONTAINMENT)	TYPE C LEAK TEST (YES OR NO)	DISTANCE TO OUTERMOST ISOLATION VALVE (ft)	VALVE TYPE
Make-up Demineralizer										
1WM190	55	30	Water	2		M-49-1	Outside	YES	1.6	Globe
1WM191	55	30	Water	2		M-49-1	Inside	YES	N/A	Check
Main Steam										
1MS001D	57	77	Steam	30.25	YES	M-35-1	Outside	NO	14.8	Gate
1MS101D	57	77	Steam	4	YES	M-35-1	Outside	NO	20.0	Globe
1MS021D	57	77	Steam	3		M-35-1	Outside	NO	15.4	Globe
1MS018D	57	77	Steam	6	YES	M-35-1	Outside	NO	32.1	Relief
1MS013D	57	77	Steam	6		M-35-1	Outside	NO	39.1	Relief

B/B-UFSAR

TABLE 6.2-58 (Cont'd)

ISOLATION VALVE NUMBER (Cont'd)	GDC REQUIREMENT MET	VALVE OPERATOR	NORMAL POSITION	SHUTDOWN POSITION	POST-ACCIDENT POSITION	POWER FAILURE POSITION	CLOSURE TIME** (sec)	ISOLATION SIGNALS	PRIMARY MODE OF ACTION	SECONDARY MODE OF ACTION	POWER SOURCE	ISOLATION VALVE CONFIGURATION
Essential Service Water												
1SX016B	57	MO	Open	Open	Open	As Is	N/*S	(Open)	A	RM	1E	10
1SX027B	57	MO	Open	Open	Open	As Is	N/*S	(Open)	A	RM	1E	10
1SX027A	57	MO	Open	Open	Open	As Is	N/*S	(Open)	A	RM	1E	10
1SX016A	57	MO	Open	Open	Open	As Is	N/*S	(Open)	A	RM	1E	10
Fire Protection												
1FP010	56	AO/S	Open	Closed	Closed	Closed	12	T	A	RM	1E	6
1FP345	56	N/A	N/A	N/A	N/A	N/A	N/A	N/A	N/A	N/A	N/A	6
Instrument Air												
1IA065	56	AO/S	Open	Open	Closed	Closed	15	T	A	RM	1E	2,6
1IA066	56	AO/S	Open	Open	Closed	Closed	15	T	A	RM	1E	2
1IA091	56	N/A	N/A	N/A	N/A	N/A	N/A	N/A	N/A	N/A	N/A	6
Instrument Penetration												
1VQ016	56	M	Closed	Closed	Closed	N/A	N/A	N/A	M	M	N/A	4
1VQ017	56	M	Closed	Closed	Closed	N/A	N/A	N/A	M	M	N/A	4
1VQ018	56	M	Closed	Closed	Closed	N/A	N/A	N/A	M	M	N/A	4
1VQ019	56	M	Closed	Closed	Closed	N/A	N/A	N/A	M	M	N/A	4
1RY075	57	M	Closed	Closed	Closed	N/A	N/A	N/A	M	M	N/A	

B/B-UFSAR

TABLE 6.2-58 (Cont'd)

ISOLATION VALVE NUMBER (Cont'd)	GDC REQUIREMENT MET	VALVE OPERATOR	NORMAL POSITION	SHUTDOWN POSITION	POST-ACCIDENT POSITION	POWER FAILURE POSITION	CLOSURE TIME** (sec)	ISOLATION SIGNALS	PRIMARY MODE OF ACTION	SECONDARY MODE OF ACTION	POWER SOURCE	ISOLATION VALVE CONFIGURATION
Make-up Demineralizer												
1WM190	55	M	Closed	Open	Closed	N/A	N/A	N/A	M	M	N/A	7
1WM191	55	N/A	N/A	N/A	N/A	N/A	N/A	N/A	N/A	N/A	N/A	7
Main Steam												
1MS001D	57	HO	Open	Closed	Closed	As Is	5.0	MS	A	RM	1E	10
1MS101D	57	AO/S	Closed	Closed	Closed	Closed	6.0	MS	A	RM	1E	11
1MS021D	57	M	Closed	Closed	Closed	N/A	N/A	N/A	M	M	N/A	14
1MS018D	57	HO	Closed	Closed	Closed	Closed	20.0	N/A	A	RM	1E	13
1MS013D	57	N/A	Closed	Closed	Closed	N/A	N/A	N/A	N/A	N/A	N/A	13

B/B-UFSAR

TABLE 6.2-58 (Cont'd)

ISOLATION VALVE NUMBER	GDC REQUIRE-MENT MET	PENETRA-TION NUMBER	FLUID	LINE SIZE (in.)	ESSEN-TIAL*	REFERENCE DRAWING	VALVE LOCA-TION (INSIDE OR OUTSIDE CONTAINMENT)	TYPE C LEAK TEST (YES OR NO)	DISTANCE TO OUTERMOST ISOLATION VALVE (ft)	VALVE TYPE
Main Steam										
1MS014D	57	77	Steam	6		M-35-1	Outside	NO	36.6	Relief
1MS015D	57	77	Steam	6		M-35-1	Outside	NO	34.1	Relief
1MS016D	57	77	Steam	6		M-35-1	Outside	NO	31.6	Relief
1MS017D	57	77	Steam	6		M-35-1	Outside	NO	29.1	Relief
1MS001B	57	85	Steam	32.75		M-35-1	Outside	NO	10.0	Gate
1MS101B	57	85	Steam	4	YES	M-35-1	Outside	NO	17.7	Globe
1MS021B	57	85	Steam	3		M-35-1	Outside	NO	11.0	Globe
1MS018B	57	85	Steam	6	YES	M-35-1	Outside	NO	16.5	Relief
1MS013B	57	85	Steam	6		M-35-1	Outside	NO	38.8	Relief
1MS014B	57	85	Steam	6		M-35-1	Outside	NO	36.3	Relief
1MS015B	57	85	Steam	6		M-35-1	Outside	NO	33.8	Relief
1MS016B	57	85	Steam	6		M-35-1	Outside	NO	31.3	Relief
1MS017B	57	85	Steam	6		M-35-1	Outside	NO	28.8	Relief
1MS001A	57	78	Steam	30.25	YES	M-35-2	Outside	NO	14.8	Gate
1MS101A	57	78	Steam	4	YES	M-35-2	Outside	NO	20.0	Globe
1MS021A	57	78	Steam	3		M-35-2	Outside	NO	15.4	Globe
1MS018A	57	78	Steam	6	YES	M-35-2	Outside	NO	32.1	Relief
1MS013A	57	78	Steam	6		M-35-2	Outside	NO	39.1	Relief
1MS014A	57	78	Steam	6		M-35-2	Outside	NO	36.6	Relief
1MS015A	57	78	Steam	6		M-35-2	Outside	NO	34.1	Relief
1MS016A	57	78	Steam	6		M-35-2	Outside	NO	31.6	Relief
1MS017A	57	78	Steam	6		M-35-2	Outside	NO	29.1	Relief
1MS001C	57	86	Steam	32.75	YES	M-35-2	Outside	NO	10.0	Gate
1MS101C	57	86	Steam	4	YES	M-35-2	Outside	NO	17.7	Globe
1MS021C	57	86	Steam	3		M-35-2	Outside	NO	11.0	Globe
1MS018C	57	86	Steam	6	YES	M-35-2	Outside	NO	16.5	Relief
1MS013C	57	86	Steam	6		M-35-2	Outside	NO	38.8	Relief
1MS014C	57	86	Steam	6		M-35-2	Outside	NO	36.3	Relief
1MS015C	57	86	Steam	6		M-35-2	Outside	NO	33.8	Relief
1MS016C	57	86	Steam	6		M-35-2	Outside	NO	31.3	Relief
1MS017C	57	86	Steam	6		M-35-2	Outside	NO	28.8	Relief

B/B-UFSAR

TABLE 6.2-58 (Cont'd)

ISOLATION VALVE NUMBER (Cont'd)	GDC REQUIRE-MENT MET	VALVE OPER-ATOR	NORMAL POSITION	SHUTDOWN POSITION	POST-ACCIDENT POSITION	POWER FAILURE POSITION	CLOSURE TIME** (sec)	ISOLA-TION SIGNALS	PRIMARY MODE OF ACTUA-TION	SECOND-ARY MODE OF ACTUA-TION	POWER SOURCE	ISOLATION VALVE CONFIGU-RATION
Main Steam												
1MS014D	57	N/A	Closed	Closed	Closed	N/A	N/A	N/A	N/A	N/A	N/A	13
1MS015D	57	N/A	Closed	Closed	Closed	N/A	N/A	N/A	N/A	N/A	N/A	13
1MS016D	57	N/A	Closed	Closed	Closed	N/A	N/A	N/A	N/A	N/A	N/A	13
1MS017D	57	N/A	Closed	Closed	Closed	N/A	N/A	N/A	N/A	N/A	N/A	13
1MS001B	57	HO	Open	Closed	Closed	As Is	5.0	MS	A	RM	1E	10
1MS101B	57	AO/S	Closed	Closed	Closed	Closed	6.0	MS	A	RM	1E	11
1MS021B	57	M	Closed	Closed	Closed	N/A	N/A	N/A	M	M	N/A	14
1MS018B	57	HO	Closed	Closed	Closed	Closed	20.0	N/A	A	RM	1E	13
1MS013B	57	N/A	Closed	Closed	Closed	N/A	N/A	N/A	N/A	N/A	N/A	13
1MS014B	57	N/A	Closed	Closed	Closed	N/A	N/A	N/A	N/A	N/A	N/A	13
1MS015B	57	N/A	Closed	Closed	Closed	N/A	N/A	N/A	N/A	N/A	N/A	13
1MS016B	57	N/A	Closed	Closed	Closed	N/A	N/A	N/A	N/A	N/A	N/A	13
1MS017B	57	N/A	Closed	Closed	Closed	N/A	N/A	N/A	N/A	N/A	N/A	13
1MS001A	57	HO	Open	Closed	Closed	As Is	5.0	MS	A	RM	1E	10
1MS101A	57	AO/S	Closed	Closed	Closed	Closed	6.0	MS	A	RM	1E	11
1MS021A	57	M	Closed	Closed	Closed	N/A	N/A	N/A	M	M	N/A	14
1MS018A	57	HO	Closed	Closed	Closed	Closed	20.0	N/A	A	RM	1E	13
1MS013A	57	N/A	Closed	Closed	Closed	N/A	N/A	N/A	N/A	N/A	N/A	13
1MS014A	57	N/A	Closed	Closed	Closed	N/A	N/A	N/A	N/A	N/A	N/A	13
1MS015A	57	N/A	Closed	Closed	Closed	N/A	N/A	N/A	N/A	N/A	N/A	13
1MS016A	57	N/A	Closed	Closed	Closed	N/A	N/A	N/A	N/A	N/A	N/A	13
1MS017A	57	N/A	Closed	Closed	Closed	N/A	N/A	N/A	N/A	N/A	N/A	13
1MS001C	57	HO	Open	Closed	Closed	As Is	5.0	MS	A	RM	1E	10
1MS101C	57	AO/S	Closed	Closed	Closed	Closed	6.0	MS	A	RM	1E	11
1MS021C	57	M	Closed	Closed	Closed	N/A	N/A	N/A	M	M	N/A	14
1MS018C	57	HO	Closed	Closed	Closed	Closed	20.0	N/A	A	RM	1E	13
1MS013C	57	N/A	Closed	Closed	Closed	N/A	N/A	N/A	N/A	N/A	N/A	13
1MS014C	57	N/A	Closed	Closed	Closed	N/A	N/A	N/A	N/A	N/A	N/A	13
1MS015C	57	N/A	Closed	Closed	Closed	N/A	N/A	N/A	N/A	N/A	N/A	13
1MS016C	57	N/A	Closed	Closed	Closed	N/A	N/A	N/A	N/A	N/A	N/A	13
1MS017C	57	N/A	Closed	Closed	Closed	N/A	N/A	N/A	N/A	N/A	N/A	13

B/B-UFSAR

TABLE 6.2-58 (Cont'd)

ISOLATION VALVE NUMBER	GDC REQUIREMENT MET	PENETRATION NUMBER	FLUID	LINE SIZE (in.)	ESSENTIAL*	REFERENCE DRAWING	VALVE LOCATION (INSIDE OR OUTSIDE CONTAINMENT)	TYPE C LEAK TEST (YES OR NO)	DISTANCE TO OUTERMOST ISOLATION VALVE (ft)	VALVE TYPE
Off-Gas										
1OG079	56	13	Air & H ₂	3	YES	M-47-2	Inside	YES	N/A	But. Fly
1OG080	56	13	Air & H ₂	3	YES	M-47-2	Inside	YES	N/A	But. Fly
1OG081	56	23	Air & H ₂	3	YES	M-47-2	Inside	YES	N/A	But. Fly
1OG057A	56	69	Air & H ₂	3	YES	M-47-2	Inside	YES	N/A	But. Fly
1OG082	56	13	Air & H ₂	3	YES	M-47-2	Outside	YES	MIN.	But. Fly
1OG083	56	69	Air & H ₂	3	YES	M-47-2	Outside	YES	MIN.	But. Fly
1OG084	56	13	Air & H ₂	3	YES	M-47-2	Outside	YES	MIN.	But. Fly
1OG085	56	23	Air & H ₂	3	YES	M-47-2	Outside	YES	MIN.	But. Fly
Process Radiation										
1PR001A	56	52	Air	1		M-78-10	Outside	YES	1.4	Globe
1PR001B	56	52	Air	1		M-78-10	Outside	YES	3.5	Globe
1PR066	56	52	Air	1		M-78-10	Outside	YES	2.3	Globe
1PR032	56	52	Air	1		M-78-10	Inside	YES	N/A	Check
1PR033A (Brwd only)	56	AL	Air	2		M-78-6	Outside	YES	MIN.	Globe
1PR033B (Brwd only)	56	AL	Air	2		M-78-6	Outside	YES	MIN.	Globe
1PR002E (Brwd only)	56	AL	Air	2		M-78-6	Outside	YES	MIN.	Globe
1PR002G (Brwd only)	56	AL	Air	2		M-78-6	Inside	YES	N/A	Check
1PR033C (Brwd only)	56	AL	Air	2		M-78-6	Outside	YES	MIN.	Globe
1PR033D (Brwd only)	56	AL	Air	2		M-78-6	Outside	YES	MIN.	Globe
1PR002F (Brwd only)	56	AL	Air	2		M-78-6	Outside	YES	MIN.	Globe
1PR002H (Brwd only)	56	AL	Air	2		M-78-6	Inside	YES	N/A	Check
Hydrogen Monitor										
1PS228A	56	45	H ₂ + Air	1/2		M-68-7	Outside	YES	MIN.	Globet
1PS229A	56	45	H ₂ + Air	1/2		M-68-7	Outside	YES	MIN.	Globet
1PS230A	56	12 (BY) 45 (BW)	H ₂ + Air	1/2		M-68-7	Outside	YES	MIN.	Globet
1PS231A	56	12 (BY) 45 (BW)	H ₂ + Air	3/4		M-68-7	Inside	YES	N/A1	Check
1PS228B	56	36	H ₂ + Air	1/2		M-68-7	Outside	YES	MIN.	Globet
1PS229B	56	36	H ₂ + Air	1/2		M-68-7	Outside	YES	MIN.	Globet
1PS230B	56	31 (BY) 36 (BW)	H ₂ + Air	1/2		M-68-7	Outside	YES	MIN.	Globet
1PS231B	56	31 (BY) 36 (BW)	H ₂ + Air	3/4		M-68-7	Inside	YES	N/A	Check

B/B-UFSAR

TABLE 6.2-58 (Cont'd)

ISOLATION VALVE NUMBER (Cont'd)	GDC REQUIRE-MENT MET	VALVE OPER-ATOR	NORMAL POSITION	SHUTDOWN POSITION	POST-ACCIDENT POSITION	POWER FAILURE POSITION	CLOSURE TIME** (sec)	ISOLA-TION SIGNALS	PRIMARY MODE OF ACTUA-TION	SECOND-ARY MODE OF ACTUA-TION	POWER SOURCE	ISOLATION VALVE CONFIGU-RATION
Off-Gas												
1OG079	56	MO	Closed	Closed	Closed	As Is	60	T	A	RM	1E	1
1OG080	56	MO	Closed	Closed	Closed	As Is	60	T	A	RM	1E	1
1OG081	56	MO	Closed	Closed	Closed	As Is	60	T	A	RM	1E	1
1OG057A	56	MO	Closed	Closed	Closed	As Is	60	T	A	RM	1E	1
1OG082	56	MO	Closed	Closed	Closed	As Is	60	T	A	RM	1E	1
1OG083	56	MO	Closed	Closed	Closed	As Is	60	T	A	RM	1E	1
1OG084	56	MO	Closed	Closed	Closed	As Is	60	T	A	RM	1E	1
1OG085	56	MO	Closed	Closed	Closed	As Is	60	T	A	RM	1E	1
Process Radiation												
1PR001A	56	AO/S	Open	Closed	Closed	Closed	4.5	T	A	RM	1E	8
1PR001B	56	AO/S	Open	Closed	Closed	Closed	4.5	T	A	RM	1E	8
1PR066	56	AO/S	Open	Closed	Closed	Closed	5.0	T	A	RM	1E	6
1PR032	56	N/A	N/A	N/A	N/A	N/A	N/A	N/A	N/A	N/A	N/A	6
1PR033A (Brwd only)	56	M	Closed	Closed	Closed	N/A	N/A	N/A	N/A	N/A	N/A	
1PR033B (Brwd only)	56	M	Closed	Closed	Closed	N/A	N/A	N/A	N/A	N/A	N/A	
1PR002E (Brwd only) 56		M	Closed	Closed	Closed	N/A	N/A	N/A	N/A	N/A	N/A	7
1PR002G (Brwd only)	56	N/A	N/A	N/A	N/A	N/A	N/A	N/A	N/A	N/A	N/A	7
1PR033C (Brwd only)	56	M	Closed	Closed	Closed	N/A	N/A	N/A	N/A	N/A	N/A	
1PR033D (Brwd only)	56	M	Closed	Closed	Closed	N/A	N/A	N/A	N/A	N/A	N/A	
1PR002F (Brwd only)	56	M	Closed	Closed	Closed	N/A	N/A	N/A	N/A	N/A	N/A	7
1PR002H (Brwd only)	56	N/A	N/A	N/A	N/A	N/A	N/A	N/A	N/A	N/A	N/A	7
Hydrogen Monitor												
1PS228A	56	S	Open	Closed	Closed	As Is	15	T	A	RM	1E	
1PS229A	56	S	Open	Closed	Closed	Open	15	T	A	RM	1E	
1PS230A	56	S	Closed	Closed	Closed	Closed	15	T	A	RM	1E	
1PS231A	56	N/A	N/A	N/A	N/A	N/A	N/A	N/A	N/A	N/A	N/A	
1PS228B	56	S	Open	Closed	Closed	Open	15	T	A	RM	1E	
1PS229B	56	S	Open	Closed	Closed	As Is	15	T	A	RM	1E	
1PS230B	56	S	Closed	Closed	Closed	Closed	15	T	A	RM	1E	
1PS231B	56	N/A	N/A	N/A	N/A	N/A	N/A	N/A	N/A	N/A	N/A	

B/B-UFSAR

TABLE 6.2-58 (Cont'd)

ISOLATION VALVE NUMBER	GDC REQUIRE-MENT MET	PENETRA-TION NUMBER	FLUID	LINE SIZE (in.)	ESSEN-TIAL*	REFERENCE DRAWING	VALVE LOCA-TION (INSIDE OR OUTSIDE CONTAINMENT)	TYPE C LEAK TEST (YES OR NO)	DISTANCE TO OUTERMOST ISOLATION VALVE (ft)	VALVE TYPE
Process Sampling										
1PS9354A	55	70	RC	3/8	YES	M-68-1	Inside	YES	N/A	Globe
1PS9354B	55	70	RC	3/8	YES	M-68-1	Outside	YES	MIN.	Globe
1PS9355A	55	70	RC	3/8	YES	M-68-1	Inside	YES	N/A	Globe
1PS9355B	55	70	RC	3/8	YES	M-68-1	Outside	YES	MIN.	Globe
1PS9356A	55	70	RC	3/8	YES	M-68-1	Inside	YES	N/A	Globe
1PS9356B	55	70	RC	3/8	YES	M-68-1	Outside	YES	MIN.	Globe
1PS9357A	55	70	RC	3/8	YES	M-68-1	Inside	YES	N/A	Globe
1PS9357B	55	70	RC	3/8	YES	M-68-1	Outside	YES	MIN.	Globe
Reactor and Contain-ment Drains to Radwaste										
1RE9157	55	65	Gas	1	YES	M-70-1	Outside	YES	2.5	DIAPH
1RE9159A	55	65	Gas	3/4	YES	M-70-1	Inside	YES	N/A	DIAPH
1RE9159B	55	65	Gas	3/4	YES	M-70-1	Outside	YES	1.0	DIAPH
1RE9160A	55	65	Gas	1	YES	M-70-1	Inside	YES	N/A	DIAPH
1RE9160B	55	65	Gas	1	YES	M-70-1	Outside	YES	1.5	DIAPH
1RE1003	55	11	Water	3	YES	M-70-1	Inside	YES	N/A	DIAPH
1RE9170	55	11	Water	3	YES	M-70-1	Outside	YES	1.0	DIAPH
1RE022 (Byron)	55	11	Water	3/4		M-70-1	Inside	YES	N/A	Relief
1RE040 (Braidwood)	55	11	Water	3/4		M-70-1	Inside	YES	N/A	Relief
Reactor Coolant Pressurizer										
1RY8025	56	27	Nitrogen	3/8	YES	M-60-6	Outside	YES	1.3	Globe
1RY8026	56	27	Nitrogen	3/8	YES	M-60-6	Inside	YES	N/A	Globe
1RY8033	56	27	Nitrogen	3/4	YES	M-60-6	Outside	YES	1.3	DIAPH
1RY8047	56	27	Nitrogen	3/4		M-60-6	Inside	YES	N/A	CHECK
1RY8028	56	44	Water	3	YES	M-60-6	Outside	YES	1.0	DIAPH
1RY8046	56	44	Water	3		M-60-6	Inside	YES	N/A	CHECK

B/B-UFSAR

TABLE 6.2-58 (Cont'd)

ISOLATION VALVE NUMBER	GDC REQUIRE- MENT MET	PENETRA- TION NUMBER	FLUID	LINE SIZE (in.)	ESSEN- TIAL*	REFERENCE DRAWING	VALVE LOCA- TION (INSIDE OR OUTSIDE CONTAINMENT)	TYPE C LEAK TEST (YES OR NO)	DISTANCE TO OUTERMOST ISOLATION VALVE (ft)	VALVE TYPE
Residual Heat Removal										
1RH8701A	55	68	RC	12	YES	M-62	Inside	NO	N/A	Gate
1RH8701B	55	68	RC	12	YES	M-62	Inside	NO	N/A	Gate
1RH8702A	55	75	RC	12	YES	M-62	Inside	NO	N/A	Gate
1RH8702B	55	75	RC	12	YES	M-62	Inside	NO	N/A	Gate

B/B-UFSAR

TABLE 6.2-58 (Cont'd)

ISOLATION VALVE NUMBER (Cont'd)	GDC REQUIREMENT MET	VALVE OPERATOR	NORMAL POSITION	SHUTDOWN POSITION	POST-ACCIDENT POSITION	POWER FAILURE POSITION	CLOSURE TIME** (sec)	ISOLATION SIGNALS	PRIMARY MODE OF ACTION	SECONDARY MODE OF ACTION	POWER SOURCE	ISOLATION VALVE CONFIGURATION
Process Sampling												
1PS9354A	55	AO/S	Closed	Closed	Closed	Closed	10	T	A	RM	1E	2
1PS9354B	55	AO/S	Closed	Closed	Closed	Closed	10	T	A	RM	1E	2
1PS9355A	55	AO/S	Closed	Closed	Closed	Closed	10	T	A	RM	1E	2
1PS9355B	55	AO/S	Closed	Closed	Closed	Closed	10	T	A	RM	1E	2
1PS9356A	55	AO/S	Closed	Closed	Closed	Closed	10	T	A	RM	1E	2
1PS9356B	55	AO/S	Closed	Closed	Closed	Closed	10	T	A	RM	1E	2
1PS9357A	55	AO/S	Closed	Closed	Closed	Closed	10	T	A	RM	1E	2
1PS9357B	55	AO/S	Closed	Closed	Closed	Closed	10	T	A	RM	1E	2
Reactor and Containment Drains to Radwaste												
1RE9157	55	AO/S	Open	Open	Closed	Closed	10	T	A	RM	1E	2
1RE9159A	55	AO/S	Open	Open	Closed	Closed	10	T	A	RM	1E	2
1RE9159B	55	AO/S	Closed	Closed	Closed	Closed	10	T	A	RM	1E	2
1RE9160A	55	AO/S	Open	Open	Closed	Closed	10	T	A	RM	1E	2
1RE9160B	55	AO/S	Open	Open	Closed	Closed	10	T	A	RM	1E	2
1RE1003	55	AO/S	Closed	Closed	Closed	Closed	10	T	A	RM	1E	2
1RE9170	55	AO/S	Open	Open	Closed	Closed	10	T	A	RM	1E	2
1RE022 (Byron)	55	N/A	Closed	Closed	Closed	N/A	N/A	N/A	N/A	N/A	N/A	2A
1RE040 (Braidwood)	55	N/A	Closed	Closed	Closed	N/A	N/A	N/A	N/A	N/A	N/A	2A
Reactor Coolant Pressurizer												
1RY8025	56	AO/S	Closed	Closed	Closed	Closed	10	T	A	RM	1E	2
1RY8026	56	AO/S	Open	Open	Closed	Closed	10	T	A	RM	1E	2
1RY8033	56	AO/S	Open	Open	Closed	Closed	10	T	A	RM	1E	6
1RY8047	56	N/A	N/A	N/A	N/A	N/A	N/A	N/A	N/A	N/A	N/A	6
1RY8028	56	AO/S	Open	Open	Closed	Closed	10	T	A	RM	1E	6
1RY8046	56	N/A	N/A	N/A	N/A	N/A	N/A	N/A	N/A	N/A	N/A	6

B/B-UFSAR

TABLE 6.2-58 (Cont'd)

ISOLATION VALVE NUMBER (Cont'd)	GDC REQUIREMENT MET	VALVE OPERATOR	NORMAL POSITION	SHUTDOWN POSITION	POST-ACCIDENT POSITION	POWER FAILURE POSITION	CLOSURE TIME** (sec)	ISOLATION SIGNALS	PRIMARY MODE OF ACTION	SECONDARY MODE OF ACTION	POWER SOURCE	ISOLATION VALVE CONFIGURATION
Residual Heat Removal												
1RH8701A	55	MO	Closed	Closed	Closed	As Is	N/A	N/A	RM	M	1E	9
1RH8701B	55	MO	Closed	Closed	Closed	As Is	N/A	N/A	RM	M	1E	9
1RH8702A	55	MO	Closed	Closed	Closed	As Is	N/A	N/A	RM	M	1E	9
1RH8702B	55	MO	Closed	Closed	Closed	As Is	N/A	N/A	RM	M	1E	9

B/B-UFSAR

TABLE 6.2-58 (Cont'd)

ISOLATION VALVE NUMBER	GDC REQUIRE-MENT MET	PENETRA-TION NUMBER	FLUID	LINE SIZE (in.)	ESSEN-TIAL*	REFERENCE DRAWING	VALVE LOCA-TION (INDSIDE OR OUTSIDE CONTAINMENT)	TYPE C LEAK TEST (YES OR NO)	DISTANCE TO OUTERMOST ISOLATION VALVE (ft)	VALVE TYPE
Safety Injection										
1SI8801A	55	26	BW	4	YES	M-61-2	Outside	NO	4.8	Gate
1SI8801B	55	26	BW	4	YES	M-61-2	Outside	NO	8.9	Gate
1SI8815	55	26	BW	3		M-61-2	Inside	NO	N/A	Check
1SI8880	55	55	Nitrogen	1		M-61-6	Outside	YES	15.5	Globe
1SI8968	55	55	Nitrogen	1		M-61-6	Inside	YES	N/A	Check
1SI8964	55	55	BW	3/4	YES	M-61-6	Outside	YES	17.8	Globe
1SI8871	55	55	BW	3/4	YES	M-61-6	Inside	YES	N/A	Globe
1SI8802A	55	59	Water	4	YES	M-61-3	Outside	NO	3.7	Gate
1SI8905A	55	59	Water	2		M-61-3	Inside	NO	N/A	Check
1SI8905D	55	59	Water	2		M-61-3	Inside	NO	N/A	Check
1SI8802B	55	73	Water	4	YES	M-61-3	Outside	NO	2.7	Gate
1SI8905C	55	73	Water	2		M-61-3	Inside	NO	N/A	Check
1SI8905B	55	73	Water	2		M-61-3	Inside	NO	N/A	Check
1SI8835	55	60	Water	4	YES	M-61-3	Outside	NO	3.3	Gate
1SI8819A	55	60	Water	2		M-61-3	Inside	NO	N/A	Check
1SI8819B	55	60	Water	2		M-61-3	Inside	NO	N/A	Check
1SI8819C	55	60	Water	2		M-61-3	Inside	NO	N/A	Check
1SI8819D	55	60	Water	2		M-61-3	Inside	NO	N/A	Check
1SI8809A	55	50	Water	8	YES	M-61-4	Outside	NO	3.7	Gate
1SI8818A	55	50	Water	6		M-61-4	Inside	NO	N/A	Check
1SI8818D	55	50	Water	6		M-61-4	Inside	NO	N/A	Check
1SI8809B	55	51	Water	8	YES	M-61-4	Outside	NO	3.3	Gate
1SI8818B	55	51	Water	6		M-61-4	Inside	NO	N/A	Check
1SI8818C	55	51	Water	6		M-61-4	Inside	NO	N/A	Check
1SI8811A	56	92	NaOH+BW	24	YES	M-61-4	Outside	NO	1.8	Gate
1SI8811B	56	93	NaOH+BW	24	YES	M-61-4	Outside	NO	1.8	Gate
1SI8890A	55	50	Water	3/4		M-61-4	Inside	NO	N/A	Globe
1SI8890B	55	51	Water	3/4		M-61-4	Inside	NO	N/A	Globe
1SI8888	55	55	Water	3/4	YES	M-61-3	Outside	YES	14.7	Globe
1SI8881	55	59	Water	3/4		M-61-3	Inside	NO	N/A	Globe

B/B-UFSAR

TABLE 6.2-58 (Cont'd)

ISOLATION VALVE NUMBER (Cont'd)	GDC REQUIRE-MENT MET	VALVE OPER-ATOR	NORMAL POSITION	SHUTDOWN POSITION	POST-ACCIDENT POSITION	POWER FAILURE POSITION	CLOSURE TIME** (sec)	ISOLA-TION SIGNALS	PRIMARY MODE OF ACTUA-TION	SECOND-ARY MODE OF ACTUA-TION	POWER SOURCE	ISOLATION VALVE CONFIGU-RATION
Safety Injection												
1SI8801A	55	MO	Closed	Closed	Open	As Is	N/*	S (Open)	A	RM	1E	5
1SI8801B	55	MO	Closed	Closed	Open	As Is	N/*	S (Open)	A	RM	1E	5
1SI8815	55	N/A	N/A	N/A	N/A	N/A	N/A	N/A	N/A	N/A	N/A	5
1SI8880	55	AO/S	Closed	Closed	Closed	Closed	10	T	A	RM	1E	6
1SI8968	55	N/A	N/A	N/A	N/A	N/A	N/A	N/A	N/A	N/A	N/A	6
1SI8964	55	AO/S	Closed	Closed	Closed	Closed	10	T	A	RM	1E	2
1SI8871	55	AO/S	Closed	Closed	Closed	Closed	10	T	A	RM	1E	2
1SI8802A	55	MO	Closed	Closed	Open	As Is	N/*	N/A	RM	M	1E	5
1SI8905A	55	N/A	N/A	N/A	N/A	N/A	N/A	N/A	N/A	N/A	N/A	5
1SI8905D	55	N/A	N/A	N/A	N/A	N/A	N/A	N/A	N/A	N/A	N/A	5
1SI8802B	55	MO	Closed	Closed	Open	As Is	N/*	N/A	RM	M	1E	5
1SI8905C	55	N/A	N/A	N/A	N/A	N/A	N/A	N/A	N/A	N/A	N/A	5
1SI8905B	55	N/A	N/A	N/A	N/A	N/A	N/A	N/A	N/A	N/A	N/A	5
1SI8835	55	MO	Open	Open	Closed	As Is	N/*	N/A	RM	M	1E	5
1SI8819A	55	N/A	N/A	N/A	N/A	N/A	N/A	N/A	N/A	N/A	N/A	5
1SI8819B	55	N/A	N/A	N/A	N/A	N/A	N/A	N/A	N/A	N/A	N/A	5
1SI8819C	55	N/A	N/A	N/A	N/A	N/A	N/A	N/A	N/A	N/A	N/A	5
1SI8819D	55	N/A	N/A	N/A	N/A	N/A	N/A	N/A	N/A	N/A	N/A	5
1SI8809A	55	MO	Open	Open	Closed	As Is	N/*	N/A	RM	M	1E	5
1SI8818A	55	N/A	N/A	N/A	N/A	N/A	N/A	N/A	N/A	N/A	N/A	5
1SI8818D	55	N/A	N/A	N/A	N/A	N/A	N/A	N/A	N/A	N/A	N/A	5
1SI8809B	55	MO	Open	Open	Closed	As Is	N/*	N/A	RM	M	1E	5
1SI8818B	55	N/A	N/A	N/A	N/A	N/A	N/A	N/A	N/A	N/A	N/A	5
1SI8818C	55	N/A	N/A	N/A	N/A	N/A	N/A	N/A	N/A	N/A	N/A	5
1SI8811A	56	MO	Closed	Closed	Open	As Is	N/*	S (Open)	A	RM	1E	
1SI8811B	56	MO	Closed	Closed	Open	As Is	N/*	S (Open)	A	RM	1E	
1SI8890A	55	AO/S	Closed	Closed	Closed	Closed	N/*	N/A	RM	M	Non 1E	
1SI8890B	55	AO/S	Closed	Closed	Closed	Closed	N/*	N/A	RM	M	Non 1E	
1SI8888	55	AO/S	Closed	Closed	Closed	Closed	10	T	A	RM	1E	2
1SI8881	55	AO/S	Closed	Closed	Closed	Closed	N/*	N/A	RM	M	Non 1E	

B/B-UFSAR

TABLE 6.2-58 (Cont'd)

ISOLATION VALVE NUMBER	GDC REQUIREMENT MET	PENETRATION NUMBER	FLUID	LINE SIZE (in.)	ESSENTIAL*	REFERENCE DRAWING	VALVE LOCATION OR OUTSIDE CONTAINMENT)	TYPE C LEAK TEST (YES OR NO)	DISTANCE TO OUTERMOST ISOLATION VALVE (ft)	VALVE TYPE
Safety Injection										
1SI8840	55	66	Water	12	YES	M-61-3	Outside	NO	3.8	Gate
1SI8824	55	73	Water	3/4		M-61-3	Inside	NO	N/A	Globe
1SI8823	55	60	Water	3/4		M-61-3	Inside	NO	N/A	Globe
1SI8841A	55	66	Water	8		M-61-3	Inside	NO	N/A	Check
1SI8841B	55	66	Water	8		M-61-3	Inside	NO	N/A	Check
1SI8825	55	66	Water	3/4		M-61-3	Inside	NO	N/A	Globe
1SI8843	55	26	BW	3/4		M-61-2	Inside	NO	N/A	Globe
Service Air										
1SA032	56	56	Air	1.50	YES	M-54-2	Outside	YES	4.4	Globe
1SA033	56	56	Air	1.50	YES	M-54-2	Inside	YES	N/A	Globe
Spent Fuel Pool Cleaning										
1FC009	56	57	Water	4		M-63	Inside	YES	N/A	Plug
1FC010	56	57	Water	4		M-63	Outside	YES	3.3	Plug
1FC011	56	32	Water	3		M-63	Outside	YES	2.0	Plug
1FC012	56	32	Water	3		M-63	Inside	YES	N/A	Plug
Steam Generator Blowdown										
1SD002C	57	80	Water	2	YES	M-48-5A	Outside	NO	53.95	Globe
1SD002D	57	80	Water	2	YES	M-48-5A	Outside	NO	66.59	Globe
1SD005B	57	80	Water	3/8	YES	M-68-8	Outside	NO	61.50	Globe
1SD002C	57	81	Water	2	YES	M-48-5A	Outside	NO	70.13	Globe
1SD002D	57	81	Water	2	YES	M-48-5A	Outside	NO	58.39	Globe
1SD005B	57	81	Water	3/8	YES	M-68-8	Outside	NO	83.24	Globe
1SD002A	57	82	Water	2	YES	M-48-5A	Outside	NO	12.86	Globe
1SD002B	57	82	Water	2	YES	M-48-5A	Outside	NO	23.63	Globe
1SD005A	57	82	Water	3/8	YES	M-68-8	Outside	NO	20.50	Globe
1SD002A	57	83	Water	2	YES	M-48-5A	Outside	NO	23.27	Globe
1SD002B	57	83	Water	2	YES	M-48-5A	Outside	NO	11.25	Globe
1SD005A	57	83	Water	3/8	YES	M-68-8	Outside	NO	36.75	Globe
1SD002E	57	88	Water	2	YES	M-48-5A	Outside	NO	62.32	Globe
1SD002F	57	88	Water	2	YES	M-48-5A	Outside	NO	63.74	Globe
1SD005C	57	88	Water	3/8	YES	M-68-8	Outside	NO	67.29	Globe
1SD002E	57	89	Water	2	YES	M-48-5A	Outside	NO	64.66	Globe
1SD002F	57	89	Water	2	YES	M-48-5A	Outside	NO	46.18	Globe
1SD005C	57	89	Water	3/8	YES	M-68-8	Outside	NO	79.20	Globe
1SD002G	57	90	Water	2	YES	M-48-5A	Outside	NO	6.0	Globe
1SD002H	57	90	Water	2	YES	M-48-5A	Outside	NO	21.71	Globe
1SD005D	57	90	Water	3/8	YES	M-68-8	Outside	NO	12.0	Globe
1SD002G	57	91	Water	2	YES	M-48-5A	Outside	NO	40.48	Globe
1SD002H	57	91	Water	2	YES	M-48-5A	Outside	NO	18.69	Globe
1SD005D	57	91	Water	3/8	YES	M-68-8	Outside	NO	35.98	Globe

B/B-UFSAR

TABLE 6.2-58 (Cont'd)

ISOLATION VALVE NUMBER	GDC REQUIREMENT MET	PENETRATION NUMBER	FLUID	LINE SIZE (in.)	ESSENTIAL*	REFERENCE DRAWING	VALVE LOCATION (INSIDE OR OUTSIDE CONTAINMENT)	TYPE C LEAK TEST (YES OR NO)	DISTANCE TO OUTERMOST ISOLATION VALVE (ft)	VALVE TYPE
1SD002C ††††	57	99	Water	2	YES	M-48-5A	Outside	NO	63.1	Globe
1SD002D ††††	57	99	Water	2	YES	M-48-5A	Outside	NO	45.1	Globe
1SD005B ††††	57	99	Water	3/8	YES	M-68-8	Outside	NO	76.2	Globe
1SD002A ††††	57	100	Water	2	YES	M-48-5A	Outside	NO	39.4	Globe
1SD002B ††††	57	100	Water	2	YES	M-48-5A	Outside	NO	24.3	Globe
1SD005A ††††	57	100	Water	3/8	YES	M-68-8	Outside	NO	52.8	Globe
1SD002E ††††	57	101	Water	2	YES	M-48-5A	Outside	NO	58.3	Globe
1SD002F ††††	57	101	Water	2	YES	M-48-5A	Outside	NO	45.6	Globe
1SD005C ††††	57	101	Water	3/8	YES	M-68-8	Outside	NO	72.9	Globe
1SD002G ††††	57	102	Water	2	YES	M-48-5A	Outside	NO	35.8	Globe
1SD002H ††††	57	102	Water	2	YES	M-48-5A	Outside	NO	20.5	Globe
1SD005D ††††	57	102	Water	3/8	YES	M-68-8	Outside	NO	50.7	Globe

B/B-UFSAR

TABLE 6.2-58 (Cont'd)

ISOLATION VALVE NUMBER (Cont'd)	GDC REQUIREMENT MET	VALVE OPERATOR	NORMAL POSITION	SHUTDOWN POSITION	POST-ACCIDENT POSITION	POWER FAILURE POSITION	CLOSURE TIME** (sec)	ISOLATION SIGNALS	PRIMARY MODE OF ACTION	SECONDARY MODE OF ACTION	POWER SOURCE	ISOLATION VALVE CONFIGURATION
Safety Injection												
1SI8840	55	MO	Closed	Closed	Open	As Is	N/A	N/A	RM	M	1E	5
1SI8824	55	AO/S	Closed	Closed	Closed	Closed	N/*	N/A	RM	M	Non 1E	
1SI8823	55	AO/S	Closed	Closed	Closed	Closed	N/*	N/A	RM	M	Non 1E	
1SI8841A	55	N/A	N/A	N/A	N/A	N/A	N/A	N/A	N/A	N/A	N/A	5
1SI8841B	55	N/A	N/A	N/A	N/A	N/A	N/A	N/A	N/A	N/A	N/A	5
1SI8825	55	AO/S	Closed	Closed	Closed	Closed	N/*	N/A	RM	M	Non 1E	
1SI8843	55	AO/S	Closed	Closed	Closed	Closed	N/*	N/A	RM	M	Non 1E	
Service Air												
1SA032 (Byron)	56	AO/S	Open	Open	Closed	Closed	4.5	T	A	RM	1E	2
1SA033 (Byron)	56	AO/S	Open	Open	Closed	Closed	4.5	T	A	RM	1E	2
1SA032 (Braidwood)	56	AO/S	Closed†††	Open	Closed	Closed	4.5	T	A	RM	1E	2
1SA033 (Braidwood)	56	AO/S	Closed†††	Open	Closed	Closed	4.5	T	A	RM	1E	2
Spent Fuel Pool Cleaning												
1FC009	56	M	Closed	Open	Closed	N/A	N/A	N/A	M	M	N/A	4
1FC010	56	M	Closed	Open	Closed	N/A	N/A	N/A	M	M	N/A	4
1FC011	56	M	Closed	Open	Closed	N/A	N/A	N/A	M	M	N/A	4
1FC012	56	M	Closed	Open	Closed	N/A	N/A	N/A	M	M	N/A	4
Steam Generator Blowdown												
1SD002C	57	AO/S	Open	Closed	Closed	Closed	7.5	T,SG	A	RM	1E	11
1SD002D	57	AO/S	Open	Closed	Closed	Closed	7.5	T,SG	A	RM	1E	11
1SD005B	57	AO/S	Open	Closed	Closed	Closed	3.0	T	A	RM	1E	11
1SD002C	57	AO/S	Open	Closed	Closed	Closed	7.5	T,SG	A	RM	1E	11
1SD002D	57	AO/S	Open	Closed	Closed	Closed	7.5	T,SG	A	RM	1E	11
1SD005B	57	AO/S	Open	Closed	Closed	Closed	3.0	T	A	RM	1E	11
1SD002A	57	AO/S	Open	Closed	Closed	Closed	7.5	T,SG	A	RM	1E	11
1SD002B	57	AO/S	Open	Closed	Closed	Closed	7.5	T,SG	A	RM	1E	11
1SD005A	57	AO/S	Open	Closed	Closed	Closed	3.0	T	A	RM	1E	11
1SD002A	57	AO/S	Open	Closed	Closed	Closed	7.5	T,SG	A	RM	1E	11
1SD002B	57	AO/S	Open	Closed	Closed	Closed	7.5	T,SG	A	RM	1E	11
1SD005A	57	AO/S	Open	Closed	Closed	Closed	3.0	T	A	RM	1E	11
1SD002E	57	AO/S	Open	Closed	Closed	Closed	7.5	T,SG	A	RM	1E	11
1SD002F	57	AO/S	Open	Closed	Closed	Closed	7.5	T,SG	A	RM	1E	11
1SD005C	57	AO/S	Open	Closed	Closed	Closed	3.0	T	A	RM	1E	11
1SD002E	57	AO/S	Open	Closed	Closed	Closed	7.5	T,SG	A	RM	1E	11
1SD002F	57	AO/S	Open	Closed	Closed	Closed	7.5	T,SG	A	RM	1E	11
1SD005C	57	AO/S	Open	Closed	Closed	Closed	3.0	T	A	RM	1E	11
1SD002G	57	AO/S	Open	Closed	Closed	Closed	7.5	T,SG	A	RM	1E	11
1SD002H	57	AO/S	Open	Closed	Closed	Closed	7.5	T,SG	A	RM	1E	11
1SD005D	57	AO/S	Open	Closed	Closed	Closed	3.0	T	A	RM	1E	11
1SD002G	57	AO/S	Open	Closed	Closed	Closed	7.5	T,SG	A	RM	1E	11
1SD002H	57	AO/S	Open	Closed	Closed	Closed	7.5	T,SG	A	RM	1E	11
1SD005D	57	AO/S	Open	Closed	Closed	Closed	3.0	T	A	RM	1E	11

B/B-UFSAR

TABLE 6.2-58 (Cont'd)

ISOLATION VALVE NUMBER (Cont'd)	GDC REQUIREMENT MET	VALVE OPERATOR	NORMAL POSITION	SHUTDOWN POSITION	POST-ACCIDENT POSITION	POWER FAILURE POSITION	CLOSURE TIME** (sec)	ISOLATION SIGNALS	PRIMARY MODE OF ACTION	SECONDARY MODE OF ACTION	POWER SOURCE	ISOLATION VALVE CONFIGURATION
1SD002C tttt	57	AO/S	Open	Closed	Closed	Closed	7.5	T,SG	A	RM	1E	11
1SD002D tttt	57	AO/S	Open	Closed	Closed	Closed	7.5	T,SG	A	RM	1E	11
1SD005B tttt	57	AO/S	Open	Closed	Closed	Closed	3.0	T	A	RM	1E	11
1SD002A tttt	57	AO/S	Open	Closed	Closed	Closed	7.5	T,SG	A	RM	1E	11
1SD002B tttt	57	AO/S	Open	Closed	Closed	Closed	7.5	T,SG	A	RM	1E	11
1SD005A tttt	57	AO/S	Open	Closed	Closed	Closed	3.0	T	A	RM	1E	11
1SD002E tttt	57	AO/S	Open	Closed	Closed	Closed	7.5	T,SG	A	RM	1E	11
1SD002F tttt	57	AO/S	Open	Closed	Closed	Closed	7.5	T,SG	A	RM	1E	11
1SD005C tttt	57	AO/S	Open	Closed	Closed	Closed	3.0	T	A	RM	1E	11
1SD002G tttt	57	AO/S	Open	Closed	Closed	Closed	7.5	T,SG	A	RM	1E	11
1SD002H tttt	57	AO/S	Open	Closed	Closed	Closed	7.5	T,SG	A	RM	1E	11
1SD005D tttt	57	AO/S	Open	Closed	Closed	Closed	3.0	T	A	RM	1E	11

B/B-UFSAR

TABLE 6.2-58 (Cont'd)

ISOLATION VALVE NUMBER	GDC REQUIREMENT MET	PENETRATION NUMBER	FLUID	LINE SIZE (in.)	ESSENTIAL*	REFERENCE DRAWING	VALVE LOCATION (INSIDE OR OUTSIDE CONTAINMENT)	TYPE C LEAK TEST (YES OR NO)	DISTANCE TO OUTERMOST ISOLATION VALVE (ft)	VALVE TYPE
Steam Generator Feedwater										
1FW009A	57	79	Water	16	YES	M-36-1	Outside	NO	13.75	Gate
1AF013A (Braidwood)	57	79	Water	4	YES	M-37	Outside	NO	73.5	Globe
1AF013A (Byron)	57	79	Water	4	YES	M-37	Outside	NO	74.4	Globe
2AF013A	57	100	Water	4	YES	M-122	Outside	NO	66.75	Globe
1AF013E (Braidwood)	57	79	Water	4	YES	M-37	Outside	NO	69.2	Globe
1AF013E (Byron)	57	79	Water	4	YES	M-37	Outside	NO	70.1	Globe
2AF013E	57	100	Water	4	YES	M-122	Outside	NO	62.5	Globe
1FW015A	57	100	Water	3/4		M-48-5A	Outside	NO	46.75	Globe
2FW015A	57	100	Water	3/4		M-121-1	Outside	NO	46.75	Globe
1FW009B	57	84	Water	16	YES	M-36-1	Outside	NO	13.75	Gate
1AF013B (Braidwood)	57	84	Water	4	YES	M-37	Outside	NO	64.5	Globe
1AF013B (Byron)	57	84	Water	4	YES	M-37	Outside	NO	65.7	Globe
2AF013B	57	101	Water	4	YES	M-122	Outside	NO	57.66	Globe
1AF013F (Braidwood)	57	84	Water	4	YES	M-37	Outside	NO	59.8	Globe
1AF013F (Byron)	57	84	Water	4	YES	M-37	Outside	NO	60.9	Globe
2AF013F	57	101	Water	4	YES	M-122	Outside	NO	53.0	Globe
1FW015B	57	101	Water	3/4		M-48-5A	Outside	NO	46.75	Globe
2FW015B	57	101	Water	3/4		M-121-1	Outside	NO	46.75	Globe
1FW009C	57	87	Water	16	YES	M-36-1	Outside	NO	13.75	Gate
1AF013C (Braidwood)	57	87	Water	4	YES	M-37	Outside	NO	62.1	Globe
1AF013C (Byron)	57	87	Water	4	YES	M-37	Outside	NO	63.9	Globe
2AF013C	57	102	Water	4	YES	M-122	Outside	NO	55.75	Globe
1AF013G (Braidwood)	57	87	Water	4	YES	M-37	Outside	NO	58.6	Globe
1AF013G (Byron)	57	87	Water	4	YES	M-37	Outside	NO	60.4	Globe
2AF013G	57	102	Water	4	YES	M-122	Outside	NO	52.25	Globe
1FW015C	57	102	Water	3/4		M-121-1	Outside	NO	46.75	Globe
2FW015C	57	102	Water	3/4		M-48-5A	Outside	NO	46.75	Globe
1FW009D	57	76	Water	16	YES	M-36-1	Outside	NO	13.75	Gate
1AF013D (Braidwood)	57	76	Water	4	YES	M-37	Outside	NO	65.3	Globe
1AF013D (Byron)	57	76	Water	4	YES	M-37	Outside	NO	68.5	Globe
2AF013D	57	99	Water	4	YES	M-122	Outside	NO	57.75	Globe
1AF013H (Braidwood)	57	76	Water	4	YES	M-37	Outside	NO	61.3	Globe
2AF049A (Byron)	57	100	Water	4	NO	M-122	Outside	NO	22.5	Check
2AF049B (Byron)	57	101	Water	4	NO	M-122	Outside	NO	22.5	Check
2AF049C (Byron)	57	102	Water	4	NO	M-122	Outside	NO	23.7	Check
2AF049D (Byron)	57	99	Water	4	NO	M-122	Outside	NO	22.6	Check
1AF049A (Braidwood)	57	79	Water	4	NO	M-37	Outside	NO	23.8	Check
1AF049B (Braidwood)	57	84	Water	4	NO	M-37	Outside	NO	23.9	Check
1AF049C (Braidwood)	57	87	Water	4	NO	M-37	Outside	NO	24.1	Check
1AF049D (Braidwood)	57	76	Water	4	NO	M-37	Outside	NO	22.9	Check
1AF049A (Byron)	57	79	Water	4	NO	M-37	Outside	NO	22.5	Check
1AF049B (Byron)	57	84	Water	4	NO	M-37	Outside	NO	22.5	Check
1AF049C (Byron)	57	87	Water	4	NO	M-37	Outside	NO	23.7	Check
1AF049D (Byron)	57	76	Water	4	NO	M-37	Outside	NO	22.6	Check
2AF049A (Braidwood)	57	100	Water	4	NO	M-122	Outside	NO	22.4	Check
2AF049B (Braidwood)	57	101	Water	4	NO	M-122	Outside	NO	24.1	Check
2AF049C (Braidwood)	57	102	Water	4	NO	M-122	Outside	NO	23.9	Check
2AF049D (Braidwood)	57	99	Water	4	NO	M-122	Outside	NO	22.9	Check

B/B-UFSAR

TABLE 6.2-58 (Cont'd)

ISOLATION VALVE NUMBER	GDC REQUIREMENT MET	PENETRATION NUMBER	FLUID	LINE SIZE (in.)	ESSENTIAL*	REFERENCE DRAWING	VALVE LOCATION (INSIDE OR OUTSIDE CONTAINMENT)	TYPE C LEAK TEST (YES OR NO)	DISTANCE TO OUTERMOST ISOLATION VALVE (ft)	VALVE TYPE
1AF013H (Byron)	57	76	Water	4	YES	M-37	Outside	NO	64.5	Globe
2AF013H	57	99	Water	4	YES	M-122	Outside	NO	54.25	Globe
1FW015D	57	99	Water	3/4		M-48-5A	Outside	NO	46.75	Globe
2FW015D	57	99	Water	3/4		M-121-1	Outside	NO	46.75	Globe
1FW035A (Braidwood)	57	79	Water	3	YES	M-36-1	Outside	NO	35.3	Globe
1FW035A (Byron)	57	79	Water	3	YES	M-36-1	Outside	NO	36.7	Globe
2FW035A	57	100	Water	3	YES	M-121-1	Outside	NO	29.0	Globe
1FW035B (Braidwood)	57	84	Water	3	YES	M-36-1	Outside	NO	36.2	Globe
1FW035B (Byron)	57	84	Water	3	YES	M-36-1	Outside	NO	36.8	Globe
2FW035B	57	101	Water	3	YES	M-121-1	Outside	NO	29.0	Globe
1FW035C (Braidwood)	57	87	Water	3	YES	M-36-1	Outside	NO	39.3	Globe
1FW035C (Byron)	57	87	Water	3	YES	M-36-1	Outside	NO	41.1	Globe
2FW035C	57	102	Water	3	YES	M-121-1	Outside	NO	32.5	Globe
1FW035D (Braidwood)	57	76	Water	3	YES	M-36-1	Outside	NO	38.9	Globe
1FW035D (Byron)	57	76	Water	3	YES	M-36-1	Outside	NO	41.6	Globe
2FW035D	57	99	Water	3	YES	M-121-1	Outside	NO	32.5	Globe
1FW039A (Braidwood)	57	79	Water	6	YES	M-36-1	Outside	NO	20.8	Gate
1FW039A (Byron)	57	79	Water	6	YES	M-36-1	Outside	NO	21.6	Gate
2FW039A	57	100	Water	6	YES	M-121-1	Outside	NO	14.5	Gate
1FW039B (Braidwood)	57	84	Water	6	YES	M-36-1	Outside	NO	20.8	Gate
1FW039B (Byron)	57	84	Water	6	YES	M-36-1	Outside	NO	21.7	Gate
2FW039B	57	101	Water	6	YES	M-121-1	Outside	NO	14.5	Gate
1FW039C (Braidwood)	57	87	Water	6	YES	M-36-1	Outside	NO	20.8	Gate
1FW039C (Byron)	57	87	Water	6	YES	M-36-1	Outside	NO	22.1	Gate
2FW039C	57	102	Water	6	YES	M-121-1	Outside	NO	14.5	Gate
1FW039D (Braidwood)	57	76	Water	6	YES	M-36-1	Outside	NO	20.8	Gate
1FW039D (Byron)	57	76	Water	6	YES	M-36-1	Outside	NO	23.0	Gate
2FW039D	57	99	Water	6	YES	M-121	Outside	NO	14.5	Gate
2FW043A	57	79	Water	3	YES	M-121-1	Outside	NO	27.25	Globe
2FW043B	57	84	Water	3	YES	M-121-1	Outside	NO	27.25	Globe
2FW043C	57	87	Water	3	YES	M-121-1	Outside	NO	27.25	Globe
2FW043D	57	76	Water	3	YES	M-121-1	Outside	NO	27.25	Globe

B/B-UFSAR

TABLE 6.2-58 (Cont'd)

ISOLATION VALVE NUMBER	GDC REQUIREMENT MET	PENETRATION NUMBER	FLUID	LINE SIZE (in.)	ESSENTIAL*	REFERENCE DRAWING	VALVE LOCATION (INSIDE OR OUTSIDE CONTAINMENT)	TYPE C LEAK TEST (YES OR NO)	DISTANCE TO OUTERMOST ISOLATION VALVE (ft)	VALVE TYPE
Waste Disposal										
1RF026	56	47	Water	2	YES	M-48-6	Inside	YES	5.8	Plug
1RF027	56	47	Water	2	YES	M-48-6	Outside	YES	4.6	Plug
1RF055 (Byron)	56	47	Water	3/4		M-48-6	Inside	YES	N/A	Relief
1RF060 (Braidwood)	56	47	Water	3/4		M-48-6	Inside	YES	N/A	Relief

B/B-UFSAR

TABLE 6.2-58 (Cont'd)

ISOLATION VALVE NUMBER (Cont'd)	GDC REQUIRE-MENT MET	VALVE OPER-ATOR	NORMAL POSITION	SHUTDOWN POSITION	POST-ACCIDENT POSITION	POWER FAILURE POSITION	CLOSURE TIME** (sec)	ISOLA-TION SIGNALS	PRIMARY MODE OF ACTUA-TION	SECOND-ARY MODE OF ACTUA-TION	POWER SOURCE	ISOLATION VALVE CONFIGU-RATION
Steam Generator Feedwater												
1FW009A	57	HO	Open	Closed	Closed	Closed	5.0	FW	A	RM	1E	10
1AF013A	57	MO	Open	Closed	Open	As Is	N/*	N/A	RM	M	1E	10
2AF013A	57	MO	Open	Closed	Open	As Is	N/*	N/A	RM	M	1E	10
1AF013E	57	MO	Open	Closed	Open	As Is	N/*	N/A	RM	M	1E	10
2AF013E	57	MO	Open	Closed	Open	As Is	N/*	N/A	RM	M	1E	10
1FW015A	57	M	Closed	Closed	Closed	N/A	N/A	N/A	M	M	N/A	14
1FW009B	57	HO	Open	Closed	Closed	Closed	5.0	FW	A	RM	1E	10
1AF013B	57	MO	Open	Closed	Open	As Is	N/*	N/A	RM	M	1E	10
2AF013B	57	MO	Open	Closed	Open	As Is	N/*	N/A	RM	M	1E	10
1AF013F	57	MO	Open	Closed	Open	As Is	N/*	N/A	RM	M	1E	10
2AF013F	57	MO	Open	Closed	Open	As Is	N/*	N/A	RM	M	1E	10
1FW015B	57	M	Closed	Closed	Closed	N/A	N/A	N/A	M	M	N/A	14
1FW009C	57	HO	Open	Closed	Closed	Closed	5.0	FW	A	RM	1E	10
1AF013C	57	MO	Open	Closed	Open	As Is	N/*	N/A	RM	M	1E	10
2AF013C	57	MO	Open	Closed	Open	As Is	N/*	N/A	RM	M	1E	10
1AF013G	57	MO	Open	Closed	Open	As Is	N/*	N/A	RM	M	1E	10
2AF013G	57	MO	Open	Closed	Open	As Is	N/*	N/A	RM	M	1E	10
1FW015C	57	M	Closed	Closed	Closed	N/A	N/A	N/A	M	M	N/A	14
1FW009D	57	HO	Open	Closed	Closed	Closed	5.0	FW	A	RM	1E	10
1AF013D	57	MO	Open	Closed	Open	As Is	N/*	N/A	RM	M	1E	10
2AF013D	57	MO	Open	Closed	Open	As Is	N/*	N/A	RM	M	1E	10
1AF013H	57	MO	Open	Closed	Open	As Is	N/*	N/A	RM	M	1E	10
2AF013H	57	MO	Open	Closed	Open	As Is	N/*	N/A	RM	M	1E	10
1FW015D	57	M	Closed	Closed	Closed	N/A	N/A	N/A	M	M	N/A	14
1FW035A	57	AO/S	Open	Closed	Closed	Closed	6.0	FW	A	RM	1E	11
2FW035A	57	AO/S	Open	Closed	Closed	Closed	6.0	FW	A	RM	1E	11
1FW035B	57	AO/S	Open	Closed	Closed	Closed	6.0	FW	A	RM	1E	11
2FW035B	57	AO/S	Open	Closed	Closed	Closed	6.0	FW	A	RM	1E	11
1FW035C	57	AO/S	Open	Closed	Closed	Closed	6.0	FW	A	RM	1E	11
2FW035C	57	AO/S	Open	Closed	Closed	Closed	6.0	FW	A	RM	1E	11
1FW035D	57	AO/S	Open	Closed	Closed	Closed	6.0	FW	A	RM	1E	11
2AF049A (Byron)	57	N/A	Closed	Closed	Closed	N/A	N/A	N/A	N/A	N/A	N/A	12
2AF049B (Byron)	57	N/A	Closed	Closed	Closed	N/A	N/A	N/A	N/A	N/A	N/A	12
2AF049C (Byron)	57	N/A	Closed	Closed	Closed	N/A	N/A	N/A	N/A	N/A	N/A	12
2AF049D (Byron)	57	N/A	Closed	Closed	Closed	N/A	N/A	N/A	N/A	N/A	N/A	12
1AF049A (Braidwood)	57	N/A	Closed	Closed	Closed	N/A	N/A	N/A	N/A	N/A	N/A	12
1AF049B (Braidwood)	57	N/A	Closed	Closed	Closed	N/A	N/A	N/A	N/A	N/A	N/A	12
1AF049C (Braidwood)	57	N/A	Closed	Closed	Closed	N/A	N/A	N/A	N/A	N/A	N/A	12
1AF049D (Braidwood)	57	N/A	Closed	Closed	Closed	N/A	N/A	N/A	N/A	N/A	N/A	12
1AF049A (Byron)	57	N/A	Closed	Closed	Closed	N/A	N/A	N/A	N/A	N/A	N/A	12
1AF049B (Byron)	57	N/A	Closed	Closed	Closed	N/A	N/A	N/A	N/A	N/A	N/A	12
1AF049C (Byron)	57	N/A	Closed	Closed	Closed	N/A	N/A	N/A	N/A	N/A	N/A	12
1AF049D (Byron)	57	N/A	Closed	Closed	Closed	N/A	N/A	N/A	N/A	N/A	N/A	12
2AF049A (Braidwood)	57	N/A	Closed	Closed	Closed	N/A	N/A	N/A	N/A	N/A	N/A	12
2AF049B (Braidwood)	57	N/A	Closed	Closed	Closed	N/A	N/A	N/A	N/A	N/A	N/A	12
2AF049C (Braidwood)	57	N/A	Closed	Closed	Closed	N/A	N/A	N/A	N/A	N/A	N/A	12
2AF049D (Braidwood)	57	N/A	Closed	Closed	Closed	N/A	N/A	N/A	N/A	N/A	N/A	12

B/B-UFSAR

TABLE 6.2-58 (Cont'd)

ISOLATION VALVE NUMBER (Cont'd)	GDC REQUIREMENT MET	VALVE OPERATOR	NORMAL POSITION	SHUTDOWN POSITION	POST-ACCIDENT POSITION	POWER FAILURE POSITION	CLOSURE TIME** (sec)	ISOLATION SIGNALS	PRIMARY MODE OF ACTION	SECONDARY MODE OF ACTION	POWER SOURCE	ISOLATION VALVE CONFIGURATION
2FW035D	57	AO/S	Open	Closed	Closed	Closed	6.0	FW	A	RM	1E	11
1FW039A	57	AO/S	Open	Closed	Closed	Closed	6.0	FW	A	RM	1E	11
2FW039A	57	AO/S	Open	Closed	Closed	Closed	6.0	FW	A	RM	1E	11
1FW039B	57	AO/S	Open	Closed	Closed	Closed	6.0	FW	A	RM	1E	11
2FW039B	57	AO/S	Open	Closed	Closed	Closed	6.0	FW	A	RM	1E	11
1FW039C	57	AO/S	Open	Closed	Closed	Closed	6.0	FW	A	RM	1E	11
2FW039C	57	AO/S	Open	Closed	Closed	Closed	6.0	FW	A	RM	1E	11
1FW039D	57	AO/S	Open	Closed	Closed	Closed	6.0	FW	A	RM	1E	11
2FW039D	57	AO/S	Open	Closed	Closed	Closed	6.0	FW	A	RM	1E	11
2FW043A	57	AO/S	Closed	Closed	Closed	Closed	6.0	FW	A	RM	1E	11
2FW043B	57	AO/S	Closed	Closed	Closed	Closed	6.0	FW	A	RM	1E	11
2FW043C	57	AO/S	Closed	Closed	Closed	Closed	6.0	FW	A	RM	1E	11
2FW043D	57	AO/S	Closed	Closed	Closed	Closed	6.0	FW	A	RM	1E	11
Waste Disposal												
1RF026	56	AO/S	Open	Open	Closed	Closed	15	T	A	RM	1E	2
1RF027	56	AO/S	Open	Open	Closed	Closed	15	T	A	RM	1E	2
1RF055 (Byron)	56	N/A	Closed	Closed	Closed	N/A	N/A	N/A	N/A	N/A	N/A	2A
1RF060 (Braidwood)	56	N/A	Closed	Closed	Closed	N/A	N/A	N/A	N/A	N/A	N/A	2A

TABLE 6.2-58 (Cont'd)

NOTE: Although the data listed are typically only given for Unit 1, the data apply to Unit 2 valves as well, except where Unit 2 data are provided separately.

* Essential systems are those systems which may be used following a containment isolation signal. Essential systems may be isolated on containment isolation signals as noted in Column Isolation Signals, but their isolation valves are supplied with 1E power to permit remote manual reopening if required.

** The valve closure times listed in column Closure Time are estimated maximum closure times. Actual measured times may vary from those listed. N/* indicates that the valve does not receive an automatic isolation signal to close, however, the valve closure time is consistent with isolation valve requirements.

*** See Figure 6.2-29.

**** For Byron, if the normal purge subsystem is used, valves 1VQ001A, 1VQ001B, 1VQ002A, and 1VQ002B may be open and valves 1VQ004A, 1VQ004B, 1VQ005A, 1VQ005B, and 1VQ005C are closed.

For Byron, if the miniflow purge subsystem is used, valves 1VQ004A, 1VQ004B, 1VQ005A, 1VQ005B, 1VQ005C may be open and valves 1VQ001A, 1VQ001B, 1VQ002A, and 1VQ002B are closed.

For Braidwood, if the miniflow purge subsystem is used, valves 1VQ004A, 1VQ004B, 1VQ005A, 1VQ005B and 1VQ005C may be open. At Braidwood, the supply and exhaust isolation valves for the normal purge system (1VQ001A, 1VQ001B, 1VQ002A, 1VQ002B) are blocked in the closed position in all modes of plant operation.

† Braidwood has gate valves.

†† Valve size is 3 inches.

††† May be opened during normal operation if service air is required for activities in the containment building.

†††† Unit 1 only.

KEY:

AL	=	Air Lock
RC	=	Reactor Coolant
BW	=	Borated Water
CCW	=	Component Cooling Water
M	=	Manual
S	=	Solenoid
MO	=	Motor Operated
HO	=	Hydraulic Operated
AO	=	Air Operated
AO/S	=	Air Operated with Solenoid Accessory
"As Is"	=	is the Safe Position
S	=	Actuates on Safety Injection
T	=	Actuates on Phase A Containment Isolation
P	=	Actuates on Phase B Containment Isolation
MS	=	Actuates on Main Steam Isolation
FW	=	Actuates on Main Feedwater Isolation
T1	=	Actuates on Containment Spray Actuation
T2	=	Actuates on Containment Vent Isolation

TABLE 6.2-58 (Cont'd)

A	=	Automatic (Air, Hydraulic, or Electrical) Operation
M	=	Manual Operation
RM	=	Remote Manual Operation
IA	=	Instrument Air
MIN.	=	Valves will be placed as close to the containment as practical.
SG	=	Actuates on Low-Low Steam Generator Level

TABLE 6.2-59

THERMAL HYDROGEN RECOMBINER PARAMETERS

Power (maximum)	48 kW
Capacity (minimum)	70 scfm*
Heater elements	
Number	15
Surface area element	1.11 ft ²
Maximum heat flux	9,800 Btu/hr/ft ²
Maximum sheath temperature	1,600 °F
Rating per element	3.2 kW
Fan	
Rating (minimum)	70 scfm
Design pressure	10 psig
Design temperature	1,400 °F
Air blast heat exchange fan	
Quantity of cooling air required at 120 °F	3,000 cfm
Temperature of entering process gas	1,300 °F
Temperature of leaving process gas	150 °F
Gas Temperature	
Inlet	150 °F to 225 °F
In recombiner chamber (max)	1,325 °F
Materials	
Heater element sheath	Incoloy 800
Outer structure	Carbon steel
Recombiner chamber	Austenitic stainless steel
Skid structure member	Carbon steel
Recombiner return air heat exchanger	Austenitic stainless steel
Dimensions	
Length	10'-5"
Depth	5'-5"
Height	8'-0"
Weight	8,000 pounds

* This value, which is based on 70°F and 14.7 psia, was converted to the Standard Conditions of 32°F and 14.7 psia for the original CORHYD analysis, resulting in 65 scfm.

TABLE 6.2-60

HYDROGEN RECOMBINER SYSTEM

CODES, STANDARDS, AND REGULATIONS

1. ASME Boiler and Pressure Vessel Code, Section III, "Plant Components," Summer Addendum of 1977
2. ASME Boiler and Pressure Vessel Code, Section II, "Material Specification," Summer Addendum of 1977
3. ASME Boiler and Pressure Vessel Code, Section VIII, Division One, Summer Addendum of 1977
4. ASME Boiler and Pressure Vessel Code, Section IX, "Welding Qualifications," Summer Addendum of 1977
5. ASME Boiler and Pressure Vessel Code Section XI, "Rules for Inservice Inspection of Nuclear Power Plant Components," Summer Addendum of 1977
6. 10 CFR 50, Appendix A, General Design Criteria 41, 42, 43, and 50
7. 10 CFR 50, Appendix B
8. IEEE 279-1971, "IEEE Criteria for Protection Systems for Nuclear Power Generating Stations."
9. IEEE 323-1974, "IEEE Qualifying Class IE Equipment for Nuclear Power Generating Stations."
10. IEEE 344-1975, "IEEE Recommended Practices for Seismic Qualification of Class IE Equipment for Nuclear Power Generating Stations"

TABLE 6.2-61

POST-LOCA PURGE SYSTEM COMPONENTS AND PARAMETERS

COMPONENT	QUANTITY, TYPE, AND NOMINAL CAPACITY
Prefilter	1VQ07F, 2VQ07F
Type	High efficiency
Quantity	2
Capacity (cfm)	400
Pressure drop: clean (inches water)	0.1
dirty (inches water)	1.0
Efficiency (% by ASHRAE 52 Test Std.)	80
Media	Fiberglass
HEPA Filters	1VQ08F, 2VQ08F 1VQ10F, 2VQ10F
Type	Nuclear grade
Quantity	4
Capacity (cfm)	400
Pressure drop: clean (inches water)	0.52
dirty (inches water)	2.0
Efficiency (% minimum 0.3 micron and larger)	99.97
Media	Glass fiber - waterproof and fire-retardant
Charcoal Absorbers	1VQ09F, 2VQ09F
Type	Tray (2 in.)
Quantity	
Capacity (cfm)	400 (120 lb.)
Pressure drop (inches water)	0.56

TABLE 6.2-61 (Cont'd)

COMPONENT	QUANTITY, TYPE, AND NOMINAL CAPACITY
Media	2 inches of impregnated charcoal
<u>Exhaust Fan</u>	1VQ03C, 2VQ03C
Type	Centrifugal
Quantity	2
Drive	Direct
Capacity (cfm)	400
External static pressure (inches water)	14.7

TABLE 6.2-62 HAS BEEN DELETED INTENTIONALLY

TABLE 6.2-62 HAS BEEN DELETED INTENTIONALLY

TABLE 6.2-63 HAS BEEN DELETED INTENTIONALLY

TABLE 6.2-63 HAS BEEN DELETED INTENTIONALLY

TABLE 6.2-64

CORE FISSION PRODUCT ENERGYAFTER 650 FULL-POWER DAYSCore Fission Product Energy*

TIME REACTOR TRIP (days)	ENERGY RELEASE RATE (watts/MWt x 10 ⁻³)	INTEGRATED ENERGY RELEASE (watt days/MWt x 10 ⁻⁴)
1	3.887	0.574
5	2.595	1.777
10	2.211	2.967
20	1.700	4.934
30	1.475	6.541
40	1.291	7.919
50	1.163	9.143
60	1.068	10.259
70	0.992	11.289
80	0.926	12.249
90	0.867	13.139
100	0.814	13.979

* Assumes release of 50 percent core halogens + 1 percent other fission products, includes 100 percent noble gases. Values are for total (β and γ) energy.

TABLE 6.2-65

FISSION PRODUCT DECAY DEPOSITION IN SUMP SOLUTION

TIME AFTER REACTOR TRIP (days)	<u>50 PERCENT HALOGENS</u>		<u>1 PERCENT OTHER FISSION PRODUCTS</u>			<u>TOTAL</u>
	ENERGY RELEASE RATE (watt/MWt)	INTEGRATED ENERGY RELEASE (watt-day/ MWt x 10 ⁻²)	ENERGY RELEASE RATE (watts/ MWt x 10 ⁻¹)	INTEGRATED ENERGY RELEASE (watt-day/ MWt x 10 ⁻²)	ENERGY RELEASE RATE (watts/ MWt x 10 ⁻¹)	INTEGRATED ENERGY RELEASE (watt-day/ MWt x 10 ⁻³)
1	145	4.27	3.78	0.536	18.28	0.481
3	49.4	5.88	2.90	1.18	7.85	0.707
5	31.0	6.65	2.59	1.73	5.69	0.838
10	18.2	7.82	2.22	2.92	4.03	1.07
20	7.63	9.03	1.77	4.89	2.53	1.39
30	3.22	9.54	1.49	6.51	1.81	1.61
40	1.36	9.76	1.30	7.90	1.44	1.77
60	0.241	9.89	1.08	10.3	1.10	2.02
80	0.043	9.91	0.935	12.3	0.940	2.22
100	0.008	9.92	0.822	14.0	0.823	2.39

TABLE 6.2-66

LINER AND CONCRETE DESIGN TEMPERATURESI. INSIDE FACE OF CONTAINMENT

A. Normal operating

Liner and Concrete	120°F
--------------------	-------

B. Accident Condition

Inside Face of Liner	280°F (Short-Term)
Inside Face of Concrete	208°F

II. OUTSIDE FACE OF CONTAINMENT

A. Normal Operating

1. Below Grade

a. Winter	50°F
b. Summer	80°F

2. Above Grade

a. Winter	0°F
b. Summer	100°F

3. Wall Area Neighboring
Auxiliary Building

70°F	(Operating Temp. of Auxiliary Building)
------	--

B. Accident Condition

The temperature at below and above grade are the same as those for Normal Operating.

TABLE 6.2-67

SUBCOMPARTMENT VOLUME DESCRIPTION

COMPART- MENT NUMBER	COMPARTMENT DESCRIPTION	COMPARTMENT VENTED TO	VENTED AREA (ft ²)
1	Loop Compartment	2, 6, 7, 7, 16	572; 578; 197; 232; 21
2	Loop Compartment	3, 7	572; 186
3	Loop Compartment	4, 7, 7	220; 219; 232
4	Loop Compartment	5, 7, 7, 28	572; 179; 232; 19.4
5	Loop Compartment	6, 7	572; 190.5
6	Loop Compartment	7, 7	199; 23.2
7	Dome	8, 11, 12, 13, 14, 15, 25, 26	80; 332.8; 504; 176; 48; 96.4; 198; 198
8	Upper Outside Crane Wall (subdivision of quadrant)	9, 15, 16	119; 133; 297
9	Upper Outside Crane Wall (subdivision of quadrant)	10, 17, 25	119; 114.8; 229.5
10	Upper Outside Crane Wall (subdivision of quadrant)	11, 18	187; 45
11	Upper Outside Crane Wall (A quadrant)	12, 19	36; 473
12	Upper Outside Crane Wall (A quadrant)	13, 20	182; 632.4
13	Upper Outside Crane Wall (subdivision of quadrant)	14, 21	119; 204
14	Upper Outside Crane Wall (subdivision of quadrant)	15, 22, 26	119; 78.8; 420.9
15	Upper Outside Crane Wall (subdivision of quadrant)	23	139.8
16	Lower Outside Crane Wall (subdivision of quadrant)	17	140

TABLE 6.2-67 (Cont'd)

COMPART- MENT NUMBER	COMPARTMENT DESCRIPTION	COMPARTMENT VENTED TO	VENTED AREA (ft ²)
17	Lower Outside Crane Wall (subdivision of quadrant)	18	266.5
18	Lower Outside Crane Wall (subdivision of quadrant)	19	140
19	Lower Outside Crane Wall (A quadrant)	20	133
20	Lower Outside Crane Wall (A quadrant)	21	140
21	Lower Outside Crane Wall (subdivision of quadrant)	22	70
22	Lower Outside Crane Wall (subdivision of quadrant)	23	140
23	Lower Outside Crane Wall (subdivision of quadrant)	16	140
24	Seal Table	18	17.5
25	Steamline Pipe Chase	17	945
26	Steamline Pipe Chase	22	841.3
27	Regenerate Heat Exchanger Compartment	7	82.87
28	Upper Pressurizer Cubicle	7	58.2

6.3 EMERGENCY CORE COOLING SYSTEM

6.3.1 Design Bases

The emergency core cooling system (ECCS) is designed to cool the reactor core and provide shutdown capability following initiation of the following accident conditions:

- a. pipe breaks in the reactor coolant system (RCS) which cause a discharge larger than that which can be made up by the normal makeup system, up to and including the instantaneous circumferential break of the largest pipe in the reactor coolant system;
- b. rupture of a control rod drive mechanism causing a rod cluster control assembly ejection accident;
- c. pipe breaks in the steam system, up to and including the instantaneous circumferential break of the largest pipe in the steam system; and
- d. a steam generator tube rupture.

The primary function of the ECCS is to remove the stored and fission product decay heat from the reactor core during accident conditions.

The ECCS provides shutdown capability for the accidents previously mentioned by means of boron injection. It is designed to tolerate a single active failure (short-term) or a single active or passive failure (long-term). It can meet its minimum required performance level with onsite or offsite electrical power.

The ECCS consists of the centrifugal charging, safety injection and residual heat removal pumps, accumulators, RHR heat exchangers and the refueling water storage tank, along with the associated piping, valves, instrumentation and other related equipment.

The design bases for selecting the functional requirements of the ECCS are derived from Appendix K limits for fuel cladding temperature, etc., following any of the above accidents as delineated in 10 CFR 50.46. The subsystem functional parameters are selected to integrate so that the Appendix K requirements are met over the range of anticipated accidents and single failure assumptions.

Reliability of the ECCS has been considered in selection of the functional requirements, selections of the particular components and location of components and connected piping. Redundant components are provided where the loss of one component would impair reliability. Valves are provided in series where isolation is desired and in parallel when flow paths are to be

established for ECCS performance. Redundant sources of the ECCS actuation signal are available so that the proper and timely operation of the ECCS will not be inhibited. Sufficient instrumentation is available so that a failure of an instrument will not impair readiness of the system. Inside the containment building, Class 1E electrical equipment required to perform a Class 1E function during normal operation and/or after an accident were originally located to safeguard against submergence as a result of a LOCA. Subsequent evaluations of the limiting single failure following a postulated LOCA resulted in increased flood levels (see Attachment D3.6). All Class 1E electrical equipment subject to submergence due to the revised flood levels was evaluated and determined to not be required for LOCA detection, mitigation, or recovery following submergence. The active components of the ECCS are powered from separate buses which are energized from offsite power supplies.

In addition, redundant sources of auxiliary onsite power are available through the use of the emergency diesel-generators to ensure adequate power for all ECCS requirements. Each diesel is capable of driving all pumps, valves, and necessary instruments associated with one train of the ECCS.

Spurious movement of a motor-operated valve due to the actuation of its positioning device coincident with a loss-of-coolant accident (LOCA) has been analyzed and found not to be credible for consideration in design. Consistent with the philosophy of designing against credible single failure, Westinghouse has investigated the mispositioning of an ECCS motor-operated valve coincident with the design-basis events. This analysis is presented in Reference 1. The following valves are blocked from inadvertent operation as described in Subsection 8.1.10: SI8802A and B, SI8806, SI8808A, B, C, and D, SI8809A and B, SI8813, SI8835, and SI8840.

A more detailed discussion regarding the spurious actuation or mispositioning of motor-operated valves in the ECCS is contained in Appendix 6.3A.

The elevated temperature of the sump solution during recirculation is well within the design temperature of all ECCS components. Consideration has been given to the potential for corrosion of various types of metals exposed to the fluid conditions prevalent immediately after the accident or during long-term recirculation operations. Elevated sump temperatures also may result in pressure locking of the containment recirculation sump isolation valves, 1/2SI8811A,B. See "Motor-Operated Valves" in this subsection for further discussion.

B/B-UFSAR

The following instruments provide information for the control and monitoring of the ECCS system and could become flooded during a postulated design-basis LOCA flooding event:

- a. Pressurizer pressure transmitters PT-0455, 0456, 0457, and 0458 could become submerged, but will have performed their intended safety function prior to submergence.
- b. Pressurizer level transmitters LT-0459, 0460, and 0461 could become submerged, but are not necessary for control of ECCS flow since three additional diverse and qualified instrument sources (identified in the emergency operating procedures) provide the operators with adequate information to assess ECCS performance.
- c. Steam generator narrow range level transmitters LT-0527 and 0537 could become submerged, but three other qualified channels per steam generator are available for verification of auxiliary feedwater flow following a postulated LOCA.
- d. The containment floor level instrumentation (LT-PC006 and LT-PC007) is available to diagnose and monitor a loss-of-coolant accident. Refer to UFSAR section 6.3.5.4 for additional details.

The instruments identified above are not relied upon to mitigate the postulated design basis LOCA or mitigate the consequences of the flooding event. Isolation valves RH8701A and RH8702A will be submerged; however, the valve motor-operator is located above the maximum predicted water level. The following air-operated valves will be submerged and inoperable but are not used for safe shutdown:

- RC8037A/B/C/D - Loop drain header valves; fail closed.
- RE9159A - Isolation valve to gas analyzer from reactor coolant drain tank; fail closed.

- RE9160A (Byron only) - Isolation valve to waste gas compressor from reactor coolant drain tank; fail closed.
- RY469 (Byron only) - Isolation valve to waste gas compressor from pressurizer relief tank; fail closed.

Environmental testing of ECCS equipment inside the containment, which is required to operate following a LOCA, is discussed in Section 3.11.

6.3.2 System Design

The emergency core cooling system (ECCS) components are designed such that a minimum of three accumulators, one charging pump, one safety injection pump, and one residual heat removal pump together with their associated valves and piping will ensure adequate core cooling in the event of a design-basis LOCA. The redundant onsite emergency diesels ensure adequate emergency power to all electrically-operated components in the event that a loss of offsite power occurs simultaneously with a LOCA, even assuming a single failure in the emergency power system such as the failure of one diesel to start.

6.3.2.1 Schematic Piping and Instrumentation Diagrams

Flow diagrams of the ECCS are shown in Drawings M-61 and M-62. Pertinent design and operating parameters for the components of the ECCS are given in Table 6.3-1. The codes and standards to which the individual components of the ECCS are designed are listed in Table 3.2-1.

The component interlocks used in different modes of system operation are listed as follows:

- a. The safety injection signal is interlocked with the following components and initiates the indicated action in the ECCS:
 1. Centrifugal charging pumps start on "S" signal.
 2. RWST suction valves to the charging pumps open on "S" signal.
 3. Safety injection containment isolation valves open on "S" signal.
 4. Normal charging path valves close on "S" signal.
 5. Charging pump miniflow isolation valves CV8110 and CV8111 close on "S" signal, concurrent with LO-2 RWST level as described in Subsection 7.6.11.
 6. Charging pump miniflow isolation valves CV8114 and CV8116 close on low RCS pressure in conjunction with an "S" signal. These valves

open to protect the pump should the RCS pressure increase above the open setpoint with an "S" signal present.

7. Safety injection pumps start on "S" signal.
 8. The RHR pumps start on "S" signal.
 9. VCT outlet isolation valves close on "S" signal.
- b. Switchover from injection mode to recirculation involves the following interlocks:
1. The suction valves (SI8811A/B) from the containment recirculation sumps open automatically when two of four RWST level instrument channels indicate a LO-2 level in the RWST in conjunction with "S" signal.
 2. The safety injection pump and charging pump recirculation suction isolation valves can be opened provided that the safety injection pump miniflow lines have been isolated.

6.3.2.2 Equipment and Component Descriptions

The component design and operating conditions are specified as the most severe conditions to which each respective component is exposed during either normal plant operation, or during operation of the ECCS. For each component, these conditions are considered in relation to the code to which it is designed. By designing the components in accordance with applicable codes, and with due consideration for the design and operating conditions, the fundamental assurance of structural integrity of the ECCS components is maintained. Components of the ECCS are designed to withstand the appropriate seismic loadings in accordance with their safety class as given in Table 3.2-1.

The major mechanical components of the ECCS are as follows:

Accumulators

The accumulators are pressure vessels partially filled with borated water and pressurized with nitrogen gas. During normal operation each accumulator is isolated from the reactor coolant system (RCS) by two check valves in series. Should the RCS pressure fall below the accumulator pressure, the check valves open and borated water is forced into the RCS. One accumulator is attached to each of the cold legs of the RCS. Mechanical operation of the swing-disc check valves is the only action required to open the injection path from the accumulators to the core via the cold leg.

Connections are provided for remotely adjusting the level and boron concentration of the borated water in each accumulator during normal plant operation as required. Accumulator water level may be adjusted either by draining to the recycle holdup tank or by pumping borated water from the refueling water storage tank to the accumulator. Samples of

the solution in the accumulators are taken periodically for checks of boron concentration.

Accumulator pressure is provided by a supply of nitrogen gas, and can be adjusted as required during normal plant operation; however, the accumulators are normally isolated from this nitrogen supply. Gas relief valves on the accumulators protect them from pressures in excess of design pressure.

The accumulators are located within the containment but outside of the secondary shield wall which protects them from missiles.

Accumulator gas pressure is monitored by indicators and alarms. The operator can take action as required to maintain plant operation within the requirements of the technical specification covering accumulator operability.

Pumps

ECCS pump specifications include a specified maximum required NPSH which the pump is required to meet. Pump vendors have verified that the required NPSH for the Byron/Braidwood pumps was less than the maximum required NPSH through testing in accordance with the criteria established by the Hydraulic Institute Standards.

Pump characteristic curves are shown in Figures 6.3-3, 6.3-4, and 6.3-5.

Refer to Subsection 3.9.3.2 and Subsection 6.3.2.5 for discussions of operability and reliability of pumps used for long-term core cooling, respectively.

Residual Heat Removal Pumps

The RHR system is normally used during the latter stages of normal reactor cooldown and when the reactor is held at cold shutdown for core decay heat removal. However, during all other plant operating periods, it is aligned to perform the low head injection function of the ECCS (see Subsection 5.4.7).

In the event of a loss-of-coolant accident the residual heat removal pumps are automatically started on receipt of an "S" signal. The residual heat removal pumps deliver water to the RCS from the refueling water storage tank during the injection phase and from the containment sump during the recirculation phase. Each residual heat removal pump is a single stage vertical centrifugal pump.

A minimum flow bypass line is provided for the pumps to recirculate and return the pump discharge fluid to the pump suction should these pumps be started with their normal flow paths blocked. Once flow is established to the RCS, the bypass line is automatically closed. This line prevents deadheading of the pumps and permits pump testing during normal operation.

The motor-operated valve in each mini-flow is interlocked to provide automatic operation. The three position control at the main control board prevents inadvertent operator isolation of the miniflow bypass line. The control switch Open-Auto-Close position control has a spring return to Auto from the Close position to prevent pump deadheading. A control switch maintained open feature is provided for the operator to block miniflow path closure during RHR pump manual starts for testing or for shutdown cooling modes. Gradual warmup of the RHR pump to RCS hot leg temperature requires that the pump recirculation path remain open for a time period longer than the flow interlock would allow. The normal position for the control switch is Auto.

The residual heat removal pumps are discussed further in Subsection 5.4.7. A pump performance curve is given in Figure 6.3-3.

Centrifugal Charging Pumps

In the event of an accident, the charging pumps are started automatically on receipt of an "S" signal and are automatically aligned to take suction from the refueling water storage tank during injection. This signal also closes the valves to isolate the normal charging line and volume control tank and opens the charging pump/refueling water storage tank suction valves to align the high head portion of the ECCS for injection. During recirculation, suction is provided from the residual heat removal pump discharge.

These pumps deliver flow to the RCS at the prevailing RCS pressure. Each centrifugal charging pump is a multistage diffuser design, barrel-type casing with vertical suction and discharge nozzles.

A minimum flow bypass line is provided on each pump discharge to recirculate flow to the pump suction after cooling via the seal water heat exchanger during normal plant operation. Recirculation flow may be temporarily redirected to the top of the VCT as necessary to assist in system fill and vent or as deemed appropriate to support plant operations. The charging pumps may be tested during power operation via the minimum flow bypass line. Solenoid actuated miniflow control valves are provided with actuation logic to isolate the miniflow lines on an "S" signal in conjunction with low-low RCS pressure. These valves open to protect the pumps should the RCS pressure increase above their "open" setpoint with an "S" signal present.

In addition to the solenoid actuated charging pump miniflow control valves, two motor-operated charging pump miniflow valves are also provided to isolate the miniflow lines at the time of switchover from safety injection to cold leg recirculation. This isolation is automatic when the refueling water storage tank (RWST) water level drops to the LO-2 setpoint in conjunction with an "S" signal.

A pump performance curve for the centrifugal charging pumps is presented in Figure 6.3-4.

Safety Injection Pumps

In the event of an accident, the safety injection pumps are started automatically on receipt of an "S" signal.

These pumps deliver water to the RCS from the refueling water storage tank during the injection phase and from the containment sump via the residual heat removal pumps during the recirculation phase.

A minimum flow bypass line is provided on each pump discharge to recirculate flow to the refueling water storage tank in the event that the pumps are started with the normal flow paths blocked. This line also permits pump testing during normal plant operation. Two parallel valves in series with a third, downstream of a common header, are provided in the minimum flow bypass line. These valves are manually closed from the control room as part of the ECCS realignment from the injection to the recirculation mode. A pump performance curve is shown in Figure 6.3-5.

Net Positive Suction Head (NPSH) - Low Temperature

As part of the chemical effects evaluations related to head loss through the containment recirculation sump strainers (in support of Generic Letter 2004-02), the NPSH analysis for the RHR pumps has been performed at low temperatures.

In accordance with the requirements specified in Regulatory Guide 1.1, the NPSH analysis at low temperatures assumes the containment atmospheric pressure is equal to the minimum containment atmospheric pressure that would be present inside containment before the loss-of-coolant accident (LOCA) event. This analysis does not credit calculated increases in containment pressure as a result of the LOCA.

Adequate net positive suction head is available to the RHR pumps.

Net Positive Suction Head (NPSH) - High Temperature

Available and required net positive suction head for ECCS pumps are shown in Table 6.3-1. The safety intent of Regulatory Guide 1.1 is met by the design of the ECCS in that adequate net positive suction head is provided to system pumps. In addition to considering the static head and suction line head, the NPSH calculations for the ECCS pumps recirculation mode assume that the vapor pressure of the liquid in the sump is equal to the containment ambient pressure. This ensures that the actual available net positive suction head is always greater than the calculated net positive suction head.

The ECCS is designed, analyzed, and tested to ensure adequate NPSH is available to system pumps. For the RHR pump NPSH calculation, when taking suction from the containment sump, the vapor pressure of the pumped liquid is assumed to be in equilibrium with containment ambient pressure (i.e., no credit is

taken for subcooling of the sump fluid). The equation for this case is:

$$\text{NPSH}_{\text{available}} = h_{\text{static head}} - h_{\text{line losses}}$$

For other system pumps, or for RHR pump NPSH when operating in other modes, this equation becomes:

$$\begin{aligned} \text{NPSH}_{\text{available}} = & h_{\text{ambient pressure}} + h_{\text{static head}} \\ & - h_{\text{line losses}} - h_{\text{vapor pressure}} \end{aligned}$$

Adequate net positive suction head is shown to be available for all pumps as follows:

1. Residual Heat Removal Pumps

The net positive suction head of the residual heat removal pumps is evaluated for normal plant cooldown operation, and for both the injection and recirculation operation for the

design-basis accident. Recirculation modes of operation gives the limiting net positive suction head requirement, and the net positive suction head available is determined from the containment water level relative to the pump elevation and the pressure drop in the suction piping from the sump to the pumps. The calculation takes credit for water level at the 377-foot elevation in the containment. The net positive suction head evaluation is based on one residual heat removal pump delivering to two RCS loops and both safety injection and both charging pump suction. This identifies the limiting single failure as the second RHR pump. The corresponding NPSH requirement is based on the runout flow resulting from this most limiting single failure.

The suction nozzle of each RHR pump is located sufficiently below the bottom of the containment sump such that the static elevation head is always greater than the head losses plus the pumps required NPSH. The head losses include all losses due to piping, elbows, tees, valves, containment recirculation sump filters, and entrance and exit losses, when assuming that the pumps in each subsystem are operating at the maximum postaccident operating conditions. See subsection 6.5.2.2 for more details.

During a LOCA, the outleakage from the Reactor Coolant System flows into the containment recirculation sumps. The sumps are filled prior to reaching the RWST LO-2 level. Filling the recirculation sumps ensures the NPSH requirements for the RHR pumps are satisfied prior to reaching the RWST LO-2 level, at which time the RHR pumps are aligned to the recirculation sumps.

During the LOCA, debris may accumulate on the screens which protect suction pipe in the sumps, resulting in flow restrictions. Calculations (Reference 5a and Reference 5b) have verified that the containment floor water level is sufficiently high above 377' elevation, upon reaching the RWST LO-2 level, to permit adequate inflow to the sumps in support of RHR pumps flow requirements. Therefore, the recirculation sumps fill with water and remain filled so that the RHR pumps NPSH requirements are satisfied prior to and during the recirculation mode of operation after a LOCA.

2. Safety Injection and Centrifugal Charging Pumps

The net positive suction head for the safety injection pumps and the centrifugal charging pumps is evaluated for both the injection and recirculation modes of operation for the design-basis accident. The end of the injection mode of operation gives the limiting net positive suction head available (minimum static head). The net positive suction head available is determined from the elevation head and vapor pressure of the water in the refueling water storage tank, the tank air space pressure, and the pressure drop in the suction piping from the tank to the pumps.

The NPSH evaluation for the centrifugal charging pumps and the safety injection pumps from the refueling water storage tank is based on all safeguard pumps operating at maximum flow. This assumption maximizes the friction losses in the suction piping between the tank and the pumps. For additional conservatism, the corresponding NPSH requirements for all pumps taking suction from the refueling water storage tank are based on maximum flows.

Preoperational full flow tests are also performed on the systems to verify calculated maximum runout conditions. This serves as a final assurance of acceptable system performance.

When the refueling water storage tank LO-2 level is reached, the safety injection and charging pumps are

manually aligned to take suction from the residual heat removal pump discharge headers. The net positive suction head requirements of these pumps are therefore satisfied by the discharge head of the residual heat removal pumps during the recirculation mode of system operation. See Subsection 6.5.2.2 for additional information.

Residual Heat Exchangers

The residual heat exchangers are conventional shell and U-tube type units. During normal cooldown operation, the residual heat removal pumps recirculate reactor coolant through the tube side while component cooling water flows through the shell side. During emergency core cooling recirculation operation, water from the containment sump flows through the tube side. The tubes are seal welded to the tube sheet.

A further discussion of the residual heat exchangers is found in Subsection 5.4.7.

Valves

Design parameters for all types of valves and equipment used in the ECCS are given in Tables 6.3-1, 6.3-2, 6.3-3, 6.3-4 and 6.3-14.

Design features employed to minimize valve leakage include:

- a. Where possible, bellows-sealed valves are used.
- b. Other valves which are normally open, except check valves and those which perform a control function, are provided with backseats to limit stem leakage when fully backseated.

- c. Normally closed globe valves are typically installed with fluid pressure under the seat to minimize steam leakage of radioactive water if packing leaks.
- d. Relief valves are enclosed, i.e., they are provided with a closed bonnet.

Motor-Operated Valves

The seating design of all motor-operated valves is of the crane flexible wedge design. This design releases the mechanical holding force during the first increment of travel so that the motor operator works only against the frictional component of the hydraulic unbalance on the disc and the packing box friction. The disc is guided throughout the full disc travel to prevent chattering and to provide ease of gate movement. The seating surfaces are hard-faced to prevent galling and to reduce wear.

Where a gasket is employed for the body to bonnet joint, it is either a fully trapped, controlled compression, spiral wound gasket with provisions for seal welding, or it is of the pressure seal design with provisions for seal welding. The valve stuffing boxes are designed with a lantern ring leakoff connection with a minimum of a full set of packing below the lantern ring and a minimum of one-half of a set of packing above the lantern ring. A full set of packing is defined as a depth of packing equal to 1-1/2 times the stem diameter. At Braidwood, the leakoff lines are capped for valves 1(2)SI8808A, 1(2)SI8808B, 1(2)SI8808C, and 1(2)SI8808D. This eliminates the potential impact of the leakoff flow on the leakrate calculations for the reactor coolant system.

The motor operator incorporates a "hammer blow" feature that allows the motor to impact the discs away from the backseat upon opening or closing. This "hammer blow" feature not only impacts the disc but allows the motor to attain its operational speed prior to impact. Valves which must function against system pressure are designed such that they function with a pressure drop equal to full system pressure across the valve disc.

In response to NRC Generic Letter 95-07, "Pressure Locking and Thermal Binding of Safety-Related Power-Operated Gate Valves," the following valves were determined to be susceptible to pressure locking: 1(2)SI8802A/B, 1(2)SI8811A/B, 1(2)CV8804A, and 1(2)RH8716A. To address this concern, the following modifications were implemented to ensure the valves continued reliability:

- 1(2)SI8802A/B valve operators were modified to ensure the valves can open under maximum expected pressure locking conditions,
- 1(2)SI8811A/B valves were equipped with a thermal relief line and relief valves,
- 1(2)SI8812A/B valves were equipped with an external bypass line,
- 1(2)CV8804A were equipped with a hole in one side of the disk, and
- 1(2)RH8716A were equipped with a hole in one side of the disk

In addition, the following administrative procedural control was implemented to protect ECCS components from the effects of pressure locking of safety-related power-operated gate valves (Reference 10):

- A precaution was added to not operate the residual heat removal pumps on recirculation flow for longer than 2.4 hours unless component cooling water is aligned to the residual heat exchangers to prevent pressure locking of component cooling water valves from the residual heat exchangers, 1(2)CC9412.

Manual Globes, Gates, and Check Valves

Gate valves employ a wedge design and are straight through. The wedge is either split or solid. All gate valves have backseat and outside screw and yoke.

Globe valves, "T" and "Y" style, are either full or reduced port with outside screw and yoke construction. Packless valve designs include both diaphragm and bellows-sealed features.

Check valves are spring-loaded lift piston types for sizes 2 inches and smaller, swing type for size 2-1/2 inches to 4 inches and tilting disc type for size 4 inches and larger. Stainless steel check valves have no penetration welds other than the inlet, outlet and bonnet. The check hinge is serviced through the bonnet. Where applicable, the stem packing and gasket of the stainless steel manual globe and gate valves are similar to those described previously for motor-operated valves. The valve stuffing boxes are designed either with or without a lantern ring leakoff connection. Carbon steel manual valves are employed to pass nonradioactive fluids only and, therefore, may not contain the double packing and seal weld provisions.

For a list of the manually operated valves in the ECCS, see Subsection 6.3.2.5.

Accumulator Check Valves (Swing-disc)

The accumulator check valve is designed with a low-pressure drop configuration with all operating parts contained within the body.

Design considerations and analyses which ensure that leakage across the check valves located in each accumulator injection line will not impair accumulator availability are as follows:

- a. During normal operation the check valves are in the closed position with a nominal differential pressure across the disc of approximately 1650 psi. Since the valves remain in this position except for testing or when called upon to open following an accident and are therefore not subject to the abuse of flowing operation or impact loads caused by sudden flow reversal and seating, they do not experience significant wear of the moving parts and are expected to function with minimal backleakage. This backleakage can be checked via the test connection as described in Subsection 6.3.4.
- b. When the RCS is being pressurized during the normal plant heatup operation in accordance with the Technical Specifications, the check valves are tested for leakage as soon as there is a stable differential pressure of about 100 psi or more across the valve. This test confirms the seating of the disc and whether or not there has been an increase in the leakage since the last test. When this test is completed, the accumulator discharge line motor-operated isolation valves are opened and the RCS pressure increase is continued. There should be no increase in leakage from this point on since increasing reactor coolant pressure increases the seating force and decreases the probability of leakage.
- c. The experience derived from the check valves employed in the emergency injection systems indicate that the system is reliable and workable; check valve leakage has not been a problem. This is substantiated by the satisfactory experience obtained from operation of the Robert Emmett Ginna Nuclear Power Plant and subsequent plants where the usage of check valves is identifiable to this application.
- d. The accumulators can accept some inleakage from the RCS without affecting availability. Continuous

inleakage would require, however, that the accumulator water volume be adjusted accordingly with technical specification requirements.

Relief Valves

Relief valves are installed in various sections of the ECCS to protect lines which have a lower design pressure than the RCS. The valve stem and spring adjustment assembly are isolated from the system fluids by a bellows seal between the valve disc and spindle. For Braidwood, the Safety Injection pump discharge header relief valves do not have bellows. Their cold differential test pressure (CDTP) is adjusted to account for the effects of back pressure on the discharge piping of the relief valves. The closed bonnet provides an additional barrier for enclosure of the relief valves. Relief valves also are installed off of the containment recirculation sump isolation valve bonnets. These are thermal relief valves designed to protect the motor-operated isolation valves from pressure locking. See "Motor-Operated Valves" in this subsection for further discussion.

Table 6.3-2 lists the ECCS relief valves with their capacities and setpoints.

Butterfly Valves

Each main residual heat removal line has an air-operated butterfly valve which is normally open and is designed to fail in the open position. The actuator is arranged such that air pressure on the discharge overcomes the spring force causing the linkage to move the butterfly to the closed position. Upon loss of air pressure, the spring returns the butterfly to the open position. These valves are left in the full open position during normal operation to maximize flow from this system to the RCS during the injection mode of the ECCS operation. These valves are used during normal residual heat removal system (RHRS) operation to control cooldown flow rate.

Each residual heat removal heat exchanger bypass line has an air-operated butterfly valve which is normally closed and is designed to fail closed. These valves are used during normal cooldown to avoid thermal shock to the residual heat exchanger and to regulate the cooldown rate.

Accumulator Motor-Operated Valve Controls

As part of the plant shutdown administrative procedures, the operator is required to close these valves. This prevents a loss of accumulator water inventory to the RCS and is done shortly after the RCS has been depressurized below the safety injection unblock setpoint. The redundant pressure and level alarms on each accumulator would remind the operator to close these valves, if any were inadvertently left open.

B/B-UFSAR

Power is disconnected to the valve operators after the valves are closed.

During plant startup, the operator is instructed via procedures to energize and open these valves when the RCS pressure reaches the safety injection setpoint. Monitor lights in conjunction with an audible repeating alarm will alert the operator should any of these valves inadvertently be left closed once the RCS pressure increases beyond the safety injection unblock setpoint. Power is disconnected to the valve operators after the valves are opened.

The accumulator isolation valves are not required to move during power operation or in a postaccident situation. For a discussion of limiting conditions for operation and surveillance requirements of these valves, refer to Technical Specification 3.5.1.

For further discussions of the instrumentation associated with these valves refer to Subsections 6.3.5, and 7.6.6.

Motor-Operated Valves and Controls

Remotely operated valves for the injection mode which are under manual control (i.e., valves which normally are in their ready position and do not require a safety injection signal) have their positions indicated on a common portion of the control board. If a component is out of its proper position, its monitor light will indicate this on the control panel. At any time during operation when one of these valves is not in the ready position for injection, this condition is shown visually on the control board.

The ECCS delivery lag times are given in Chapter 15.0. The accumulator injection time varies as the size of the assumed break varies since the RCS pressure drop will vary proportionately to the break size.

Inadvertent mispositioning of a motor-operated valve due to a malfunction in the control circuitry in conjunction with an accident has been analyzed and found not to be a credible event.

Table 6.3-3 is a listing of motor-operated isolation valves in the ECCS showing interlocks, automatic features and position indications.

Periodic visual inspection and operability testing of the motor operated valves in the ECCS ensures that there is no potential for impairment of valve operability due to boric acid crystallization which could result from valve stem leakage.

Air-Operated Valves and Controls

Table 6.3-14 lists the ECCS air-operated valves. Valves designated as "Fail Closed" or "Fail Open" will fail to the safe position upon the loss of either electrical power or air supply to the valve operator.

All valves are provided with the red/green position indication on the main control board (MCB), except HCV 606/607, FCV 618/619, and HCV-943 which have continuous position indication expressed as a percentage of valve opening.

Some valves are provided with monitor lights on the MCB. (See Subsection 7.5.1 for a discussion of monitor lights.)

Automatic positioning signal is provided on some valves that are normally open or on valves that could require periodic opening during normal plant operation.

The provisions discussed and listed in Table 6.3-14 plus administrative controls ensure proper positioning of air-operated valves during LOCA and RHR cooling.

6.3.2.3 Applicable Codes and Classifications

Applicable industry codes and classifications for the ECCS are discussed in Subsection 3.9.3.

6.3.2.4 Materials Specifications and Compatibility

Materials employed for components of the ECCS are given in Table 6.3-4. Materials are selected to meet the applicable material requirements of the codes in Table 3.2-1 and the following additional requirements:

- a. All parts of components in contact with borated water are fabricated of, or clad with, austenitic stainless steel or equivalent corrosion resistant material.
- b. All parts of components in contact (internal) with sump solution during recirculation are fabricated of austenitic stainless steel or equivalent corrosion resistant material.
- c. Valve seating surfaces are hard-faced with Stellite Number 6 or an equivalent to prevent galling and to reduce wear.
- d. Valve stem materials are selected for their corrosion resistance, high tensile properties, and resistance to surface scoring by the packing.

6.3.2.5 System Reliability

Reliability of the ECCS is considered in all aspects of the system from initial design to periodic testing of the components during plant operation. The ECCS is a two-train, fully redundant, engineered safety feature. The system has been designed and proven by analysis to withstand any single credible active failure during injection, or active or passive failure during recirculation and maintain the performance objectives desired in Subsection 6.3.1. This capability is demonstrated by the failure mode and effects analysis presented in Table 6.3-10. Two trains of pumps, heat exchangers, and flow paths are provided for redundancy as only one train is required to satisfy the system performance requirements. The initiating signals for the ECCS are derived from independent

sources as measured from process (e.g., low pressurizer pressure) or environmental variables (e.g., containment pressure). Redundant, as well as functionally independent variables, are measured to initiate the safeguards signals. Each train is physically separated and protected where necessary so that a single event cannot initiate a common failure. Power sources for the ECCS are divided into two independent trains supplied from the emergency buses from offsite power. Sufficient diesel-generating capacity is maintained onsite to provide required power to each train. The diesel generators and their auxiliary systems are completely independent and each supplies power to one of the two ECCS trains.

The reliability program extends to the procurement of the ECCS components in that only designs which have been proven by past use in similar applications are acceptable for use. The quality assurance program (see Chapter 17.0) ensures receipt of components only after manufacture and test to the applicable codes and standards.

The preoperational testing program ensures that the systems as designed and constructed will meet the functional requirements as calculated in design.

The ECCS is designed with the ability for on-line testing of most components so the availability and operational status can be readily determined.

In addition to the above, the integrity of the ECCS is assured through examination of critical components during the routine in-service inspection.

a. Active Failure Criteria

The ECCS is designed to accept a single failure following its initiation without loss of its protective function. The system design will tolerate the failure of any single active component in the ECCS itself or in the necessary associated service systems at any time during the period required for system operation following the initiating event.

A single active failure analysis is presented in Table 6.3-5, and demonstrates that the ECCS can sustain the failure of any single active component in either the short-1 or long-term and still meet the level of performance for core cooling.

Since the operation of the active components of the ECCS following a steamline break is identical to that following a loss-of-coolant accident, the same analysis is applicable and the ECCS can sustain the

failure of any single active component and still meet the level of performance for the addition of shutdown reactivity.

b. Passive Failure Criteria

A passive failure is the structural failure of a static component which limits the components effectiveness in carrying out its design function. Examples include cracks in pipes, valve packing leaks, or pump seal failures.

A single passive failure analysis is presented in Table 6.3-6. It demonstrates that the ECCS can sustain a single passive failure during the long-term phase and still retain an intact flow path to the core to supply sufficient flow to maintain the core covered and affect the removal of decay heat. The procedure followed to establish the alternate flow path also isolates the component which failed.

The following philosophy provides for necessary redundancy in component and system arrangement to meet the intent of the General Design Criteria on a single failure as it specifically applies to failure of passive components in the ECCS. Thus, for the long-term, the system design is based on accepting either a passive or an active failure. Passive failures are assumed to occur at 24 hours or greater after a Loss of Coolant Accident.

Redundancy of Flow Paths and Components for Long-Term Emergency Core Cooling

In design of the ECCS, Westinghouse utilizes the following criteria:

- a. During the long-term cooling period following a loss of coolant, the emergency core cooling flow paths shall be separable into two subsystems, either of which can provide minimum core cooling functions and return spilled water from the floor of the containment back to the RCS.
- b. Either of the two subsystems can be isolated and removed from service in the event of a leak outside the containment.
- c. Adequate redundancy of check valves is provided to tolerate failure of a check valve during the long-term period as a passive component.
- d. Should one of these two subsystems be isolated in this long-term period, the other subsystem remains operable.

- e. Provisions are also made in the design to detect leakage from components outside the containment, collect this leakage, and provide for maintenance of the affected equipment.
- f. There are no motor-operated valves inside the containment that are required to operate submerged under postaccident conditions.

Thus, for the long-term emergency core cooling function, adequate core cooling capacity exists with one flow path removed from service.

Reliability of Pumps Used for Long-Term Cooling

The ECCS active pump applications have gathered extensive operating time. These pumps are seismically qualified by a combination of analyses and tests, which includes structural and operability analysis. Each pump is tested in the vendor's shop to verify hydraulic and mechanical performance. Performance is again checked at the plant site during preoperational system checks periodically per ASME Inservice Testing criteria. Pump design is specified, with strong consideration given to shaft critical speed, bearing, and seal design. Thermal transient and 100-hour endurance tests have been completed on the centrifugal charging and the safety injection pumps. Additional rotor dynamics tests have been performed on the centrifugal charging pumps, which are the highest speed applications. A thermal transient analysis has been performed on the RHR pump; this analysis is supported by the vendor's test on a similar design.

Endurance and leak determination testing has been completed on the mechanical seals by the seal supplier or long-term seal reliability has been demonstrated by previous industry operating experience and by technical evaluation. Seal testing included various temperature, pressure, radiation, and boric acid concentration levels. These test conditions were substantially elevated over those expected during normal or post-accident conditions, or test differences were technically evaluated on a case-by-case basis to justify and document the long-term reliability and operability of the seals.

The reliability program extends to the procurement of the ECCS components so that only designs which have been proven by past use in similar applications are acceptable for use. For example, the equipment specification for the ECCS pumps (safety injection, centrifugal charging, and residual heat removal pumps) require them to be capable of performing their long-term cooling function for 1 year. The same type of pumps have been used extensively in other operating plants. Their function during recurrent normal power and cooldown operations in other plants has successfully demonstrated their performance capability. Reliability tests and inspections (see Subsection 6.3.4.2) further confirm their long-term operability. Nevertheless, design provisions are included that would allow maintenance of ECCS pumps, if necessary, during long-term operation.

The operability of two independent ECCS subsystems ensures that sufficient emergency core cooling capability will be available in the event of a LOCA assuming the loss of one subsystem through any single failure consideration. Either subsystem operating in conjunction with the accumulators is capable of supplying sufficient core cooling to limit the peak cladding temperatures within acceptable limits for all postulated break sizes ranging from the double ended break of the largest RCS cold leg pipe downward. In addition, each ECCS subsystem provides long-term core cooling capability in the recirculation mode during the accident recovery period.

All ECCS equipment has been designed to perform its system operating function for at least 1 year without any periodic maintenance. The specific accident scenario and the associated emergency operating procedures determine the continuous period of time, from the onset of the accident, that each subsystem of ECCS pumps (CV, SI, RH) is required to operate in support of the long-term core cooling function of the ECCS. The two independent ECCS subsystems or trains allow maintenance to be performed on any pump, if it is necessary, during long-term operation.

The NRC has revised its guidance for determining susceptibility of PWR recirculation sump screens to the effects of debris blockage during design basis accidents requiring recirculation operation of the ECCS or Containment Spray System (CSS). The revised guidance was developed as part of the efforts to resolve Generic Safety Issue (GSI)-191, "Assessment of Debris Accumulation on PWR Sump Performance".

For the evaluation of PWR recirculation performance in the context of GSI-191, the NRC has specified the extended period of time for long term core cooling is considered to be 30 days. Therefore, the CSS and ECCS system components have been evaluated and have been found acceptable for 30 days of operation under debris laden fluid conditions. The resolution to GSI-191 is covered in more details in UFSAR Section A1.82.

Managing Gas Accumulation

On January 11, 2008, the NRC issued Generic Letter 2008-01, Managing Gas Accumulation in Emergency Core Cooling, Decay Heat Removal, and Containment Spray Systems (Reference 7). Generic Letter 2008-01 requested licensees to evaluate the licensing basis, design, testing, and corrective action programs for the Emergency Core Cooling, Decay Heat Removal, and Containment Spray systems to ensure that gas accumulation is maintained less than the amount that challenges operability of these systems, and that appropriate action is taken when conditions adverse to quality are identified. As a consequence, evaluations have been performed that resulted, in part, in the development of void acceptance criteria, identification of gas susceptible locations in piping, development of periodic gas monitoring procedures for these locations, and the acceptance of some locations that could potentially accumulate voids that were determined to be benign. The piping systems addressed in the response to Generic Letter 2008-01 have the potential to develop voids and pockets of

entrained gases. Maintaining the pump suction and discharge piping sufficiently full of water is necessary to ensure that the system will perform properly and will inject the flow assumed in the safety analysis into the Reactor Coolant System or containment upon demand. This will also prevent damage from pump cavitation or water hammer, and pumping of unacceptable quantities of non-condensable gas (e.g., air, nitrogen, or hydrogen) into the reactor vessel following an ECCS start signal or during shutdown cooling. There are some piping locations that cannot be fully vented due to the physical layout and inability to dynamically vent the piping. These locations have been evaluated in accordance with Generic Letter 2008-01 and do not adversely affect the ability of the systems to perform their specified safety functions.

The implementation of TSTF-523 (Ref. 9) has formally incorporated the Managing Gas Accumulation program into Technical Specifications. Surveillance Requirements 3.4.6.4, 3.4.7.4, 3.4.8.3, 3.5.2.3, 3.6.6.9, 3.9.5.2, and 3.9.6.3 utilize ultrasonic inspection or manual venting to verify that the CV, SI, RH, and CS systems are sufficiently filled with water. The frequency of these Surveillance Requirements is controlled under the Surveillance Frequency Control Program.

Proper initial fill and venting of the ECCS ensures that water hammer will not occur in ECCS lines. In addition, there are several other reasons why gas voids are unlikely to exist when the ECCS systems are initiated for accident mitigation. The pump suction lines and the cold leg RHR and SI discharge lines experience a positive pressure at all times, except for brief intervals during refueling. This pressure is provided by the RWST gravity head or pump head if it is in operation. The positive head ensures that no in leakage of air will result from a pressure boundary leak. Periodic surveillance tests create flow through these lines, which would purge gas voids. Vents are provided at high points in the ECCS piping inside and outside containment. A listing of the vent valves inside containment is provided in Table 6.3-16. The vent valves are used as appropriate when there is a risk of air voids due to maintenance activities.

Table 6.3-17 provides a list of potential permanent void locations. These locations cannot be fully vented due to the physical layout and sweeping the voids is not feasible. The void locations have been evaluated in accordance with Generic Letter 2008-01 and do not adversely affect ECCS or CS system functions.

Subsequent Leakage from Components in Safeguards Systems

With respect to piping and mechanical equipment outside the containment, considering the provisions for visual inspection and leak detection, leaks will be detected before they propagate to major proportions. A review of the equipment in the system indicates that the largest sudden leak potential would be the sudden failure of a pump shaft seal. Evaluation of leak rate, assuming only the presence of a seal retention ring around the pump shaft, showed flows less than 50 gpm would result. Piping leaks, valve packing leaks, or flange gasket leaks are of a nature to build up slowly with time and are considered less severe than the pump seal failure.

Larger leaks in the ECCS are prevented by the following:

- a. The piping is classified in accordance with ANS Safety Class 2 and receives the ASME Class 2 quality assurance program associated with this safety class.
- b. The piping, equipment, and supports are designed to ANS Safety Class 2 seismic classification permitting no loss of function for the design-basis earthquake.
- c. The system piping is located within a controlled area on the plant site.
- d. The piping system receives periodic pressure tests and is accessible for periodic visual inspection.
- e. The piping is austenitic stainless steel which, due to its ductility, can withstand severe distortion without failure.

Based on this review, the design of the auxiliary building and related equipment is based upon handling of leaks up to a maximum of 50 gpm. Means are also provided to detect and isolate such leaks in the emergency core cooling flow path within 30 minutes. The passive leak is postulated to begin after 24 hours following a LOCA, which is consistent with the NRC's application of the single failure criteria for ECCS systems as discussed in SECY-77-439.

Figure 6.3-2a is a simplified illustration of the ECCS. The notes provided with Figure 6.3-2a contain information relative to the operation of the ECCS in its various modes of operation (injection, cold leg recirculation and hot leg recirculation).

Flow rates to the RCS are provided in Chapter 15.0, where appropriate, for the accident analyses. The accident analysis flow rates are developed from certified pump performance curves and calculated system resistances based on test data and surveillance procedure acceptance criteria consistent with plant piping layouts. Minimum ECCS safeguards flow rates are determined by degrading the weakest certified pump performance curves and assuming that the injection line with the lowest resistance spills to containment (to maximize spill). Maximum ECCS flow rates are determined by enhancing the strongest pump performance curves, minimizing the spill line flow, and including any contribution from the positive displacement pump, if in service. The current accident analysis considers the positive displacement pump administratively isolated and the maximum ECCS flow rate has no input from the positive displacement pump. Typically, the accident analysis ECCS flowrates include additional margin below the minimum flowrates and above the maximum flowrates shown in Figures 6.3-3, 6.3-4, and 6.3-5.

The analysis for ECCS Recirculation includes the impact of limited blockage for the safety injection throttle valves on the discharge of the charging pumps to the RCS cold legs, and the throttle valves on the discharge of the safety injection pumps to the RCS Cold Legs and Hot Legs. The internal components to these valves including the trim assembly have been replaced in response to GSI-191. The modified valves have been tested at Wyle Laboratories with design basis debris loading condition; the test results indicated a limited amount of blockage. The impact of the limited blockage on the ECCS flow rates to the RCS has been evaluated with acceptable results on core Peak Clad Temperatures and long term core cooling (Reference 5c).

Maximum ECCS flow rates to the RCS for the ECCS recirculation analysis have been developed from certified vendor curves by enhancing the strongest pump performance curve. Minimum ECCS flow rates have been determined by degrading the weakest pump, including the RH pump. Pump performance requirements from the ECCS Injection Phase analysis are limiting for the RH pump minimum performance curve.

Lag Times

Lag times for initiation and operation of the ECCS is limited by pump startup time and consequential loading sequence of these motors onto the safeguard buses. Most valves are normally in the position conducive to safety; therefore, valve opening time is not considered for these valves. With offsite power available, all pump and valve motors are started immediately upon receipt of the "S" signal. In the case of a loss of offsite power, a 12-second delay is assumed for diesel startup and actuation of the sequencer logic before the pumps and valves are loaded according to the sequencer. The charging pumps will be applied to the buses in 12 seconds, the safety injection pumps will start in 17 seconds, and the residual heat removal pumps in 22 seconds. These times refer to time after the diesel generators receive their signals to start.

During plant operations for power generation, startup or hot standby modes, one charging pump is normally operating as part of the chemical and volume control system and continues to operate as long as offsite power is available. During plant operations in the hot shutdown, cold shutdown, and refueling modes, only one charging pump is permitted to operate with either offsite or onsite electrical power available.

The remaining charging pumps have power locked out to address reactor coolant system cold overpressurization considerations. Under accident conditions which result in automatic emergency core cooling system actuation, two centrifugal charging pumps are automatically started on offsite power, if available, or emergency onsite power. Both pumps continue to operate until their operation is terminated via operator action.

Potential Boron Precipitation

Boron precipitation in the reactor vessel can be prevented by a backflush of cooling water through the core to reduce boil-off and resulting concentration of boric acid in the water remaining in the reactor vessel.

Three flow paths are available for hot leg recirculation of sump water. Each SI pump can discharge to two hot legs with suction taken from the RHR pump discharge. Each SI pump flow path provides an individual train of hot leg flow. In addition, either RHR pump can discharge through the common cross connect line and inject water through two hot legs. Normal operator response is to align an RHR pump to the hot legs through the SI8840 valve and both SI pumps to the hot legs. Sufficient flow to prevent boron precipitation only requires one SI pump aligned to the associated hot legs.

Loss of one pump or one flow path or one complete train will not prevent hot leg recirculation since redundant pumps and flow paths are available for use.

Boric acid buildup considerations during long-term cooling have been addressed in Reference 2, which presents the method, assumptions, and results of analysis for a typical four-loop plant. During cold leg recirculation for a cold leg pipe break, the analysis shows that boric acid concentrations within the reactor vessel and core regions remain at acceptable levels up to the time of the initiation of hot leg recirculation.

B/B-UFSAR

An analysis has been performed to determine the maximum boron concentration in the reactor vessel following a hypothetical LOCA. This analysis used the method and assumptions described in Reference 2 with additional assumptions documented in Reference 6. The following are the principal input parameters:

*Reactor core power, 102% of	3586.6 MWt
Total inventory of boric acid solution (includes RCS, SI accumulators, RWST)	4.76 x 10 ⁶ lb _m
Initial average boric acid concentration	1.444 w/o
Effective vessel volume (core and upper plenum volume to the bottom of cold leg nozzles)	1050 ft ³
Safety injection subcooling	No subcooling assumed
Containment pressure	14.7 psia
Boron measurement uncertainty	25 ppm

The analysis considers the increase in boric acid concentration in the reactor vessel during the long-term cooling phase of a

*This power level and measurement uncertainty bounds the MUR power uprate Rated Thermal Power level including measurement uncertainty.

LOCA assuming a conservatively small effective vessel volume, including only the free volumes of the reactor core and the upper plenum below the bottom of the hot leg nozzles. This assumption conservatively neglects the mixing of boric acid solution with directly connected volumes, such as the reactor vessel lower plenum. Additional assumptions are documented in Reference 6. The calculation of boric acid concentration in the reactor vessel considers a cold leg break of the reactor coolant system in which steam is generated in the core from decay heat while the boron associated with the boric acid solution is completely separated from the steam and remains in the effective vessel volume.

The results of the analysis show that the maximum allowable boric acid concentration established by the NRC, which is the boric acid solubility limit minus 4 w/o, will not be exceeded in the vessel if hot leg recirculation is initiated 6.0 hours after the LOCA inception. (See Subsections 6.3.2.8 and 15.6.5.2.)

The safety injection flow to the reactor coolant system hot legs (assuming failure of one ECCS train), will exceed the decay heat mass boil-off. The hot leg flow will dilute the reactor vessel boron concentration by passing relatively dilute boron solution from the hot leg through the vessel to the cold leg break location. High head charging flow will continue to be provided to the reactor coolant system cold legs and will preclude any boron concentration buildup in the vessel for breaks in the hot leg.

Following initial switchover to hot leg recirculation, Byron and Braidwood will remain in this mode of operation. Hot leg recirculation provides simultaneous hot and cold leg recirculation and provides sufficient flow to both hot and cold legs of the loops in order to prevent excessive boron concentration in the reactor vessel during long-term operation following a LOCA. This method complies with the requirements of the NRC staff position concerning boron dilutions.

6.3.2.6 Protection Provisions

The provisions taken to protect the system from damage that might result from dynamic effects are discussed in Section 3.6. The provisions taken to protect the system from missiles are discussed in Section 3.5. The provisions to protect the system from seismic damage are discussed in Sections 3.7, 3.9, and 3.10. Thermal stresses on the RCS are discussed in Section 5.2.

6.3.2.7 Provisions for Performance Testing

Test lines are provided for performance testing of the ECCS system as well as individual components. These test lines and instrumentation are shown in Drawing M-61. All pumps have

miniflow lines for use in testing operability. Additional information on testing can be found in Subsection 6.3.4.2.

6.3.2.8 Manual Actions

Operator action (both short term and long term) required for the various modes of ECCS operation to mitigate the consequences of a loss-of-coolant accident (LOCA) or steamline break, as well as other accident conditions, are presented in the Emergency Operating Procedures. These procedures discuss the alarms/indications available to the operator to lead him to take the appropriate actions. The discussion provided below, constitutes an outline of the operator action required following a LOCA or steamline break.

The primary function of the safety injection system (SIS) is to provide emergency core cooling (ECC) in the event of a LOCA resulting from a break in the primary reactor coolant system (RCS) or to provide emergency boration in the event of a steamline break accident resulting from a break in the secondary steam system.

ECC following a LOCA is divided into three phases:

a. Short-Term Core Cooling/Cold Leg Injection Phase

The cold leg injection phase is defined as that period during which borated water is delivered from the refueling water storage tank (RWST) and accumulators to the RCS cold legs. During this phase, no operator actions are required to ensure proper ECCS operation.

b. Long-Term Core Cooling/Cold Leg Recirculation

The cold leg recirculation phase is that period during which borated water is recirculated from the containment sump to the RCS cold legs. Operator actions are required to establish the cold leg recirculation phase. These actions are detailed in Table 6.3-7 and are not required prior to 10 minutes following event initiation.

c. Long-Term Core Cooling/Hot Leg Recirculation Phase

The hot leg recirculation phase is that period during which borated water is recirculated from the containment sump to both the RCS hot legs and RCS cold legs. Operator actions required to establish hot leg recirculation are detailed in the Table 6.3-7 and are not required until approximately 6.0 hours following event initiation. |

The emergency boration following a steamline break accident would occur only during the injection phase. The function of the SIS during this phase would be to inject borated water into the RCS with sufficient shutdown reactivity to compensate for the change in RCS volume and counteract any reactivity increase caused by the resulting cooldown. The SIS would continue to inject borated water from the RWST until the RCS conditions have stabilized, the accident has been identified as a steamline break, and the criteria for safety injection termination are satisfied. The operator should then take action to terminate ECCS operation.

During shutdown, the following operator actions pertain to the isolation of ECCS equipment and would effect a LOCA during the time accumulator isolation valves are closed with power locked out. (Startup is not addressed since shutdown is more limiting due to the higher core decay heat generation.)

- a. At 1900 psig, the operator is instructed to manually block the automatic safety injection (SI) signal. This action disarms the SI signals from the pressurizer pressure transmitters along with the steam pressure transmitters. The other SI signal, containment high pressure, is armed and will actuate safety injection if the setpoint is exceeded. Manual SI actuation is also available.
- b. At/below 1000 psig, the operator closes and locks out the SI accumulator isolation valves. At RCS temperature below 350°F (will be completed prior to reaching 330°F), he also locks out and tags the two safety injection pumps and one high head charging pump. At this time, two residual heat removal pumps (LH safety injection) would be available from either automatic or manual SI actuation. An exception is made in the case of power lockout to the safety injection pumps under certain circumstances. Analyses have shown that under certain circumstances at least one high head safety injection pump is required to mitigate the consequences of a loss of decay heat removal event during reduced inventory conditions.
- c. At less than 360 psig and 350°F, the operator aligns the residual heat removal (RHR) system suction to the reactor coolant system. The valves in the line from the refueling water storage tank (RWST) are closed.

The significance of these actions on the mitigation of a LOCA when power is locked out to the isolation valves is that:

- a. Between 1000 psig and 360 psig, a portion of the ECCS may be actuated automatically on containment

high pressure or high steamline differential pressure signals or manually by the operator. The equipment that can be energized are two RHR pumps and one high head charging pump. Subsequently, the operator would reinstitute power at the motor control centers to the other high head charging pump, the two SI pumps, and the accumulator isolation valves.

- b. Below 360 psig, the system is in the RHR cooling mode. The operator would realign the RHR system per plant emergency procedure, as the RHR and the high head charging pumps could still be initiated by an automatic high containment pressure signal, or by manual actuation. Subsequently, the operator would reinstitute power at the motor control centers to the other high head charging pump, the two SI pumps, and the accumulator isolation valves.

Safety Significance During Shutdown

Comparing plant cooldown and heatup, the limiting case for a LOCA would be during a plant cooldown rather than a plant heat-up because the core decay heat generation would be higher. The ECCS analysis conforms to the acceptance criteria of 10 CFR 50.46 so that initiation of the LOCA is at 102% of full licensed power rating and corresponding RCS conditions. This power level assumption is 102% of the pre-MUR full licensed power rating. This power level bounds the MUR full licensed power rating including measurement uncertainty consistent with 10 CFR 50 Appendix K. Some of the reasons why the analysis would be more limiting than LOCA during shutdown are:

- a. a LOCA initiated during shutdown would have reduced decay heat generation since the reactor, in general, would have been zero power for an extended period of time;
- b. the core-stored energy during shutdown would be reduced due to the RCS uniform temperature condition at a reduced temperature; and,
- c. the energy content of the RCS would be lower.

Furthermore, the probability of the occurrence of a LOCA during this period along with the critical flaw size needed to break the RCS piping at reduced pressure clearly indicates that a LOCA is considered to be incredible. These arguments are provided in the following sections.

- a. Between 1000 psig and 400 psig: For the purpose of calculating the probability of a LOCA, a conservative time of 7 hours is assumed to cool the plant from 500°F to 350°F. The annual probabilities of small and large LOCA were estimated at 10^{-3} and 10^{-4} per year in WASH-1400.* Assuming this same failure rate holds at reduced pressure (this assumption is not realistic since normal operation serves as a proof test for lower pressure operating modes as discussed later), the probability of a LOCA during heatup/cooldown periods (assuming two heatup/cooldown cycles per year) would be:

*WASH-1400, "Reactor Safety Study," U.S. NRC, October, 1975.

B/B-UFSAR

Small LOCA $3.2 \times 10^{-6}/\text{yr.}$

Large LOCA $3.2 \times 10^{-7}/\text{yr.}$

These can be compared to the total meltdown probabilities for small LOCA and large LOCA initiating events analyzed in WASH-1400:

Small LOCA $2 \times 10^{-5}/\text{yr.}$

Large LOCA $3 \times 10^{-6}/\text{yr.}$

Therefore, even if there were no pipe break protection for these heatup/cooldown periods, it is concluded that such events add only a small increase to the meltdown risk due to the short time periods involved.

b. A break of RCS piping at reduced pressure: Below 1000 psig, an RCS piping break is considered incredible under these low pressure conditions since normal operation serves as a proof test against a break. Calculations of critical flaw size for the reactor coolant piping show that at 1000 psi internal pressure:

1. A break cannot occur for a part through-wall flaw regardless of orientation.
2. For a circumferential through-wall flaw, a catastrophic break is not possible.
3. For a through-wall longitudinal flaw, the critical flaw size is in excess of 70 inches.

Therefore, postulated RCS piping flaws of critical size for internal pressure below 1000 psig cannot exist since they would have previously failed at the normal operating pressure (2235 psig).

c. Below 360 psig: After several hours into the cooldown procedure (a minimum time is approximately 4 hours) when the RCS pressure and temperature have decreased to 360 psig and 350°F, the RHR system is placed in operation. This system has a 600 psig design pressure and a break of this system is also considered highly unlikely. However, the proof test argument given above for RCS piping does not apply to the piping in this system.

The provisions to isolate these lines and the ECCS capability for core cooling should a leak or

break develop during this mode of operation are as follows. Any leakage of the RHR system piping would be expected to occur when the system is initially pressurized at 360 psig. The RCS is at this time under manual control by the reactor operator. The reactor operator is monitoring the pressurizer level and the RCS loop pressure so that any significant leakage from the RHR system would be immediately detected. When leakage is detected, then the operator would isolate the RHR system and identify the location and cause. Since the decay heat generation 4 hours after shutdown is about 1.2% of full power, the RCS fluid temperature is at about 350°F and the core stored energy is essentially removed, the operator would have ample time to isolate the RHR loop.

Therefore, in spite of the low probability of occurrence and the fact that certain failure modes for a pipe break do not exist during cooldown at an RCS pressure of 1000 psig, the plant operation procedures are as follows:

1. At a pressure between 800 and 1000 psig, RCS depressurization is discontinued; the operator will continue to cool down the RCS to 360°F.
2. At/below 1000 psig and approximately 360°F, the operator will close and lock out the accumulator isolation valves.

The above plant operating procedures will ensure that the accumulator isolation valves will not be locked out prior to about 4 hours after reactor shutdown for a cooldown rate of 50°F/hr.

A conservative analysis has determined that the peak clad temperature resulting from a large break LOCA would be significantly less than 2200°F Acceptance Criteria limit using the ECCS equipment available 2-1/2 hours after reactor shutdown.

The following assumptions were used in the analysis:

1. The RCS fluid is isothermal at a temperature of 425°F and a pressure of 1000 psig.
2. The core and metal sensible heat above 425°F has been removed.
3. The hot spot occurs at the core midplane.
4. The peak fuel heat generation during full power operation of 12.88 kW/ft (102% of 12.63 kW/ft) will be used to calculate adiabatic heatup.

5. At 2-1/2 hours using decay heat in conformance with Appendix K of 10 CFR 50, the peak heat generation rate is 0.174 kW/ft.
6. As previously noted in the original response, two low head SI pumps and one high head charging pump are available from either manual SI actuation or automatic actuation by the containment HI-1 signal. However, for this analysis the loss of one low head safety injection pump was assumed.
7. No liquid waste is present in the reactor vessel at the end of blowdown.
8. A large cold leg break is considered.

For a postulated LOCA at the cooldown condition of 1000 psig, previous calculations show that the clad does not heat up above its initial temperature during blowdown. Proceeding from the end of blowdown and assuming adiabatic heatup of the fuel and clad at the hot spot, an increase of 850°F was calculated during the lower plenum refill transient of 169.7 seconds. During reflood, the core and downcomer water levels rise together until steam generation in the core becomes sufficient to inhibit the reflooding rate. At that time, heat transfer from the clad at the hot spot to the steam boil-off and entrained water will commence. This heat removal process will continue as the water level in the core rises while the downcomer is being filled with safety injection water. The reflood transient was evaluated by considering two bounding cases:

1. Downcomer and core levels rise at the same rate. No cooling due to steam boil-off is considered at the hot spot. Quenching of the hot spot occurs when the core water level reaches the core midplane.
2. Core reflooding is delayed until the SI pumps have completely filled the downcomer. No cooling due to steam boil-off is considered at the hot spot until the downcomer is filled. The full downcomer situation may then be compared with the results of the ECCS analysis for Byron/Braidwood to obtain a bounding clad temperature rise thereafter.

For Case 1 described above, the water level reaches the core midplane 95.3 seconds after bottom of core recovery. The temperature rise during reflood at the hot spot from adiabatic heatup is 478°F, which results in a peak clad temperature of approximately 1753°F.

For Case 2, the delay due to downcomer filling is 76.6 seconds. The corresponding temperature rise at the hot spot from adiabatic heatup is 384°F, which gives a hot spot clad temperature of 1660°F.

The clad temperature at the time when the downcomer has filled for the DECLG, $C_D = 0.6$ submitted to satisfy 10 CFR 50.46 requirements are 1994.2°F and 2057°F at the 6.0 and 7.5 foot elevations, respectively.

Core reflooding in the shutdown case under consideration will be more rapid from this point on due to less steam generation at the lower core power level in effect; decay heat input at any given elevation is less in the shutdown case. The combination of more rapid reflooding and lower power in the fuel ensures that the clad temperature rise during reflood will be less for the shutdown case than for the design basis case.

No manual actions are required of the operator for proper operation of the ECCS during the injection mode of operation. Only limited manual actions are required by the operator to realign the system for the cold leg recirculation mode of operation. These actions are delineated in Table 6.3-7. After approximately 6.0 hours the system is realigned for hot leg recirculation in order to control the boric acid concentration in the reactor vessel.

The changeover from the injection mode to recirculation mode is initiated automatically and completed manually by operator action from the main control room. Protection logic is provided to automatically open the two safety injection system recirculation sump isolation valves when two of four refueling water storage tank level channels indicate a refueling water storage tank LO-2 level in conjunction with the initiation of the engineered safeguards actuation signal ("S" signal). This automatic action would align the two residual heat removal pumps to take suction from the containment sump and to deliver directly to the RCS. It should be noted that the residual heat removal pumps would continue to operate during this changeover from injection mode to recirculation mode.

The two charging pumps and the two safety injection pumps would continue to take suction from the refueling water storage tank, following the above automatic action, until manual operator action is taken to align these pumps in series with the residual heat removal pumps.

The refueling water storage tank level protection logic consists of four level channels with each level channel assigned to a separate process control protection set. Four refueling water storage tank level transmitters provide level signals to corresponding normally deenergized level channel bistables. Each level channel bistable would be energized upon reaching the RWST Level LO-2 setpoint.

A two-out-of-four coincident logic is utilized in both protection cabinets A and B to ensure a trip signal in the event that

two of the four level channel RWST Level LO-2 bistables are energized. This trip signal, in conjunction with the "S" signal, provide the actuation signal to automatically open the corresponding containment sump isolation valves.

The LO-2 refueling water storage tank level signal is also alarmed to inform the operator to initiate the manual action required to realign the charging and safety injection pumps for the recirculation mode. The manual switchover sequence that must be performed by the operator is outlined in Table 6.3-7. Following the automatic and manual switchover sequence, the two residual heat removal pumps take suction from the containment sump and deliver borated water directly to the RCS cold legs. A portion of the Train A residual heat removal pump discharge flow would be used to provide suction to the two charging pumps which would also deliver directly to the RCS cold legs. A portion of the discharge flow from the Train B residual heat removal pump would be used to provide suction to the two safety injection pumps which would also deliver directly to the RCS cold legs. As part of the manual switchover procedure (Table 6.3-7, Step 5), the suctions of the safety injection and charging pumps are cross-connected so that one residual heat removal pump can deliver flow to the reactor coolant system and both safety injection and charging pumps, in the event of the failure of either residual heat removal pump.

Manual resetting of the system level safety injection signal by the operator prior to receipt of the RWST LO-2 level signal, will not disable the automatic switchover from the injection mode to the recirculation mode. However, an individual reset circuit exists to reset the automatic opening of the containment recirculation sump valves. An indicating light is provided with this reset circuit to make the operator aware that he has reset the automatic switchover function. The indicating light has a push-to-test feature to allow the operator to verify that it has not burned out.

See Section 7.5 for process information available to the operator in the control room following an accident.

The RWST level LO-3 alarm alerts operators to initiate containment spray pump switchover from the RWST to the containment recirculation sumps. Containment Spray (CS) pump switchover requires manually opening the CS pump sump suction valves (CS009A&B) and manually closing the CS pump RWST suction valves (CS001A&B). These actions provide the CS pumps with a long-term suction source from the containment recirculation sumps.

In order to eliminate the potential for air entrainment from the RWST suction lines into the ECCS and CS pumps, any pump that has not been aligned to the recirculation sumps or RHR pump discharge, upon reaching the RWST empty level following a LOCA, is secured. Upon establishing a suction path from the recirculation sumps or RHR pump discharge, the associated ECCS and/or CS pumps are restarted to assure cooling flow is maintained. The RWST empty level should not be reached following a LOCA unless multiple

equipment failures and/or operator errors occur during switchover to cold leg recirculation. No alarm exists for the RWST empty level; therefore, the empty level is determined via the RWST level indicators in the main control room. The specific RWST empty level value is given in the Emergency Operating Procedures.

Adequacy of the Refueling Water Storage Tank (RWST) Volume

The RWST has been sized to provide adequate water source for the RCS during the ECCS injection phase and during switchover to the recirculation phase.

The shortest times available for ECCS injection and switchover are as follows.

Time Allowance for Safety Injection Mode of ECCS Operation:

The cold leg injection mode of ECCS operation consists of the ECCS pumps (residual heat removal pumps, safety injection pumps, and charging pumps) and the containment spray pumps (if Containment pressure reaches the HI-3 setpoint) taking suction from the RWST and delivering to the RCS and containment, respectively. During cold leg injection mode, operators diagnose the accident and verify safety system actuation. To provide time for these activities a minimum allowance of 10 minutes of cold leg injection mode is provided prior to the first manual operator action required for switchover to cold leg recirculation mode. Cold leg injection mode time is shortest following a large break LOCA since all ECCS and CS pumps inject, resulting in the fastest depletion of the RWST.

The minimum time allowance for cold leg injection mode following a large break LOCA is verified acceptable based upon the following assumptions, which establish the bases for the associated Refueling Water Storage Tank (RWST) Level Setpoints (Reference 4):

- a) The RWST water volume available for injection mode operation is based upon the volume between the RWST Low Level and the RWST LO-2 Level, including allowance for instrumentation uncertainty.
- b) Containment and RCS pressure are conservatively assumed to be 0 psig to maximize ECCS and CS pump flow rate, resulting in maximum RWST depletion rate.
- c) Flow out of the RWST during the injection mode includes conservative allowances for two pumps of each type (RH, SI, CV, CS) operating at maximum flow rates.

Following a small break LOCA, the RHR pumps and CS pumps do not contribute to RWST depletion since RCS pressure remains above RHR pump shutoff head and containment pressure is not expected to reach the CS pump autostart setpoint. Therefore, significantly more than 10 minutes of injection mode time is available under most LOCA conditions.

The length of time for injection mode could be increased by lowering the RWST Level LO-2 setpoint. However, this would result in decreased time available for completing the manual actions required for switchover to recirculation mode prior to reaching the RWST empty level. Therefore, the RWST LO-2 Level is optimized to benefit both available time for injection mode and available time to complete switchover to recirculation mode.

Time Allowance for Switchover to Recirculation Mode of ECCS Operation:

Following a LOCA, ECCS switchover from cold leg injection mode to cold leg recirculation mode is initiated upon receipt of the RWST level LO-2 alarm. The RWST level LO-2 alarm initiates the automatic and manual operator actions necessary to align the RHR pump suction to the containment recirculation sumps and to align RHR pump discharge to the suction of the SI and CV pumps to assure a long term ECCS pump suction source. The RWST level LO-2 alarm in conjunction with an SI signal initiates automatic opening of the containment recirculation sump isolation valves (SI8811A&B), which aligns the suction of the RHR pumps to the containment recirculation sumps. The RWST level LO-2 alarm also alerts the operator to initiate the manual actions required to align RHR pumps discharge to the suction of the SI and CV pumps. The volume between the RWST level LO-2 alarm and the RWST empty level provides sufficient time for operators to complete manual actions to align the discharge of the RHR pumps to the suction of the SI and CV pumps. The major steps of the ECCS switchover emergency procedure are outlined on Table 6.3-7.

The following is an outline of the bases for demonstrating operator capability of completing time critical manual actions for switchover to cold leg recirculation. These bases are detailed in Reference 4.

The time available to complete manual actions for switchover to cold leg recirculation is dependent upon factors such as LOCA size, RCS pressure, ECCS pump flow rates, gravity backflow from the RWST to the recirculation sumps, ECCS valve stroke time, operator communication techniques, and operator training on the switchover emergency procedure. Available switchover time following both a large break LOCA and a small break LOCA is evaluated.

A large break LOCA results in the shortest available switchover time due to rapid RWST depletion caused by containment spray pump actuation and maximum RHR pump injection flow to the RCS due to low RCS pressure. However, following a large break LOCA, injection from the RHR pumps alone provides the required core cooling flow. Plant design features provide automatic alignment of the RHR pumps suction to the recirculation sumps via automatic opening of the recirculation sump isolation valves (SI8811A&B), therefore, required core cooling flow is established automatically following a large break LOCA. In the event the manual actions to align RHR pump discharge to the suction of the SI and CV pumps are not completed prior to reaching the RWST empty level, required core cooling capability will be maintained by the RHR pumps.

Following a small break LOCA, the RWST will deplete much slower than a large break LOCA since high RCS pressure prevents RHR pump injection and containment spray pump actuation on HI-3 containment pressure is not expected. Under these conditions, switchover to recirculation is not time critical since a relatively large amount

of time is available. However, if the containment spray pumps actuate during the injection mode, the RWST level LO-2 alarm could be reached in a relatively short period of time, necessitating switchover to the recirculation mode. If RCS pressure remains above RHR pump shutoff head pressure under these conditions, only the SI and CV pumps are capable of providing core cooling flow. Therefore, completing the manual actions to align RHR pump discharge to the suction of the SI and CV pumps becomes time critical since the SI and CV pumps will lose their suction source unless manual switchover actions are completed prior to reaching the RWST empty level. Since the possibility of CS pump actuation exists following a small break LOCA, the containment spray pump flow rate is conservatively included when calculating available switchover time following a small break LOCA.

Time available to complete switchover to recirculation is dependent upon three parameters: (1) RWST volume between the RWST level LO-2 alarm and the RWST empty level, (2) Flow rate out of the RWST during the switchover process, and (3) Time required to complete two milestone manual actions within the switchover procedure. These two actions are closing the SI8812A&B valves and opening either the CV8804A or the SI8804B valve. Closing the SI8812A&B valves reduces RWST outflow by eliminating backflow from the RWST to the containment recirculation sumps (if backflow is occurring due to low containment pressure) and realigning RHR pump suction from the RWST to the recirculation sumps. Backflow from the RWST to recirculation sumps will not occur if containment pressure is relatively high since the check valves in line with the RWST will be closed. Opening the CV8804A or SI8804B valve provides a flow path from RHR pump discharge to both SI and both CV pump suctions, therefore, this is the final action required to complete switchover to cold leg recirculation. In order to maximize available switchover time following a LOCA, it is desirable to close the SI8812A&B valves after the SI8811A&B valves open to reduce RWST water gravity backflow to the recirculation sumps. Reference 4 assumes 0 psig containment pressure, therefore, backflow from the RWST to the recirculation sumps is assumed maximum. Reference 4 also conservatively bases RWST outflow rate on a worst case single failure of one SI8812 valve failing to close, which results in backflow for the entire duration of the switchover evolution.

Capability to complete time critical manual actions for switchover to cold leg recirculation is demonstrated by performance of procedure B(w)EP ES-1.3 on the plant simulator with LOCA conditions. During the simulated LOCA, the time between receipt of the RWST level LO-2 alarm and the time of closing a single SI8812 valve is recorded. The volume of RWST water consumed up to and including closing the SI8812 valve is calculated based on RWST outflow rate and this time interval. Since flow rate is reduced in magnitude after closing the SI8812 valves, the time remaining to complete switchover is calculated based on the reduced RWST outflow rate and the remaining RWST water volume to the RWST empty level. Capability of completing switchover to cold leg recirculation following the worst case single failure is time validated by comparing actual operator action time against the calculated available time.

A heating system controlled by thermostat is designed to maintain the RWST water temperature greater than 40°F during the winter.

The RWST heating system consists of an electric-to-water heat exchanger with a water circulating pump, piping, and valves as shown in Drawing M-61. The entire heating system is Category II (non-safety-related). None of the electrical power, control, or instrumentation circuits are designed to meet single failure criteria or Seismic Category I requirements.

The heating system is connected to the RWST with 2-inch Category II piping. Protection against inadvertent draining of the tank in the event of a pipe break is provided by a Category I standpipe on the return side of the system, and a Category I manual shutoff valve at the Category I/II interface on the supply side. If a break occurs in the Category II portion of the system, alarms will result from drainage into the auxiliary building sumps and also from the RWST level when the tank is drained to the low level alarm point. Drainage from the low level alarm point to the minimum Technical Specification tank level through a fully severed 2-inch line, on the discharge side of the RWST heating pumps, would require in excess of 45 minutes. This would afford sufficient time to take action to close the isolation valve.

In the event a line break occurs on the suction side of the heating pump downstream of the manual isolation valve, the maximum flow from the line would be 260 gpm. This line break has negligible impact on the time available to complete switchover to cold leg recirculation mode since it depletes the RWST relatively slowly when compared to the combined flow from the ECCS pumps, CS pumps, and gravity backflow from the RWST to the recirculation sumps as a result of a different, more limiting assumed single failure (Reference 4).

Electric power for this system is derived from the following non-safety-related (non-Class 1E) buses:

Pump Motor (power and control) - 480 BMCC #134V5
(1AP48E)

Heater (power) - 480-V Switchgear 1346 (1AP17EN).

Heater ACB Control - 125-Vdc Distribution Panel 114
(1DC06EB).

Instrumentation - Miscellaneous Control System Panel #1PA2JC and 480-V MCC 134V5 (1AP48E).

The RWST vent is routed to the indoor auxiliary building filtered ventilation system. To prevent the RWST vent from freezing during cold weather, heat tracing has been provided for the portion of the vent pipe which is external to the tank or located outdoors.

6.3.3 Performance Evaluation

Accidents which require ECCS operation

- a. the accidental depressurization of the main steam system,
- b. a loss of reactor coolant from small breaks in pipes or from cracks in large pipes,
- c. a major reactor coolant system pipe break (LOCA),
- d. a major secondary system pipe break, and
- e. a steam generator tube rupture.

Accidental Depressurization of the Main Steam System

The most severe core conditions resulting from an accidental depressurization of the main steam system are associated with an inadvertent opening of a single steam dump, relief, or safety valve.

The inadvertent opening with failure to close of a single steam dump, relief, or safety valve is considered representative of the various events that could cause an accidental depressurization of the main steam system. Should more than one valve open and fail to close, the resulting depressurization transient would be enveloped by the major secondary system pipe break analysis.

Safety injection system actuation is initiated by any of the following:

- a. low pressurizer pressure signal,
- b. low steamline pressure,
- c. high containment pressure, or
- d. manual actuation.

A safety injection signal will rapidly trip the main turbine, close all feedwater control valves, trip the main feedwater pumps, and actuate isolation valves.

Following the actuation signal, the suction of the centrifugal charging pumps is diverted from the volume control tank to the refueling water storage tank. The charging pumps then pump RWST water through the header and injection line into the cold legs of each loop. The safety injection pumps also start automatically but provide no flow when the RCS is at normal pressure. The passive injection system accumulators and the low head system also provide no flow at normal RCS pressure.

Results and Conclusions of Accidental Depressurization of Main Steam System

The assumed steam release is typical of the capacity of any single steam dump, relief, or safety valve. The boron solution provides sufficient negative reactivity to maintain the reactor well below criticality. The assumed cooldown for this case is more rapid than the actual case of steam release from all steam generators through one steam dump, relief, or safety valve. The transient is quite conservative with respect to cooldown since no credit is taken for the energy stored in the system metal, other than that of the fuel elements, or the energy stored in the steam generators. Since the transient occurs over a period of about 5 minutes, the neglected stored energy is likely to have a significant effect in slowing the cooldown. The analysis shows that there will be no return to criticality after reactor trip assuming a stuck rod cluster control assembly, with offsite power available, and assuming a single failure in the ESF. Since the reactor does not return criticality a DNBR less than 1.30 does not exist.

Loss of Reactor Coolant from Breaks in Small Pipes or from Cracks in Large Pipes which Actuate Emergency Core Cooling System

A LOCA is defined as a break of the reactor coolant system piping or of any line connected to the system. Breaks of small cross sections will cause expulsion of the coolant at a rate which can be accommodated by the charging pumps, which would maintain an operational water level in the pressurizer permitting the operator to execute an orderly shutdown.

The maximum break size for which the normal makeup system can maintain the pressurizer level is obtained by comparing the calculated flow from the RCS through the postulated break against the charging pump makeup flow at normal reactor coolant system pressure, i.e., 2250 psia. A makeup flow rate from one centrifugal charging pump is adequate to sustain pressurizer level at 2250 psia for a break through a 0.375-inch diameter hole. This break results in a loss of approximately 17.5 lb/sec (127 gpm at 130°F and 2250 psia).

The safety injection signal stops normal feedwater flow by closing the main feedwater line isolation valves and initiates emergency feedwater flow by starting auxiliary feedwater pumps.

The small break analysis deals with breaks of up to 1.0 ft² in area, where the safety injection pumps play an important role in the initial core recovery because of the slower depressurization of the RCS.

The RCS depressurization and water level transients show that for a break of approximately 3.0 inch equivalent diameter, the transient is turned around and the core is recovering prior to accumulator injection. For a 3.5-inch equivalent diameter break, the core remains uncovered with a decreasing level until accumulator action. Thus, the maximum break size showing core recovery prior to accumulator injection will be approximately 3.0 inch equivalent diameter. Accumulator injection commences when pressure reaches 585 psig, i.e., approximately 1200 seconds for the 3.0-inch break size.

Results and Conclusions from Analysis of Small Break LOCA

The analysis of this break has shown that the high head portion of the emergency core cooling system, together with accumulators, provides sufficient core flooding to keep the calculated peak cladding temperature below required limits of 10 CFR 50.46. Hence, adequate protection is afforded by the ECCS in the event of a small break LOCA.

Major Reactor Coolant System Pipe Breaks (LOCA)

A major LOCA is defined as a break 1.0 ft² or larger of the reactor coolant system piping including the double-ended break of the largest pipe in the reactor coolant system or of any line connected to that system. The boundary considered for loss-of-coolant accidents as related to connecting piping is defined in Section 3.6.

Should a major break occur, depressurization of the reactor coolant system results in a pressure decrease in the pressurizer. Reactor trip occurs when the pressurizer low-pressure trip setpoint is reached. The safety injection system is actuated when the appropriate pressurizer low-pressure setpoint is reached. Reactor trip and safety injection system actuation are also provided by a high containment pressure signal. These countermeasures will limit the consequences of the accident in two ways:

- a. Reactor trip and borated water injection provide additional negative reactivity insertion to supplement void formation in causing rapid reduction of power to a residual level corresponding to fission product decay heat.
- b. Injection of borated water ensures sufficient flooding of the core to prevent excessive cladding temperatures.

When the pressure falls below approximately 585 psi, the accumulators begin to inject borated water. The conservative assumption is made that accumulator water injected bypasses the core and goes out through the break until the termination of the blowdown phase. This conservatism is again consistent with the final acceptance criteria.

The pressure transient in the reactor containment during a LOCA affects ECCS performance in the following ways. The time at which end of blowdown occurs is determined by zero break flow which is a result of achieving pressure equilibrium between the RCS and the containment. In this way, the amount of accumulator water bypass is also affected by the containment pressure since the amount of accumulator water discharged during blowdown is dependent on the length of the blowdown phase and RCS pressure at end of blowdown. During the reflood phase of the transient, the density of the steam generated in the core is dependent on the existing containment pressure. The density of this steam affects the amount of steam which can be vented from the core to the break for a given downcomer head, the core reflooding process, and thus, the ECCS performance. It is through these effects that containment pressure affects ECCS performance.

For breaks up to and including the double ended severance of a reactor coolant pipe, the ECCS will limit the cladding temperature to well below the melting point and ensure that the core will remain in place and substantially intact with its essential heat transfer geometry preserved. See Table 15.6-1 for ECCS sequence of events.

Conclusions - Thermal Analysis

For breaks up to and including the double ended severance of a reactor coolant pipe, the emergency core cooling system will meet the acceptance criteria as presented in 10 CFR 50.46, as follows:

- a. The calculated peak fuel element cladding temperature provides margin to the requirement of 2200°F.
- b. The amount of fuel element cladding that reacts chemically with water or steam does not exceed 1% of the total amount of Zircaloy in the reactor.
- c. The cladding temperature transient is terminated at a time when the core geometry is still amenable to cooling. Nowhere are the cladding oxidation limits of 17% exceeded during or after quenching.
- d. The core temperature is reduced and decay heat is removed for an extended period of time as required by the long-lived radioactivity remaining in the core.

ECCS Line Breaks

In the ECCS analysis, the large break single failure is the loss of one RHR (low head) pump and the small break single failure is the loss of one ECCS train. This means that for a large break, credit could be taken for two high head charging pumps and one low head pump; for the small break, credit could be taken for one high head and one low head pump. The following is a discussion of the modeling procedure for the ECCS minimum safeguards and the flow splitting from a break of an ECCS injection line.

The current design for both small and large breaks assumes that at least one train is available for delivery of water to the RCS. This means that one pump in each subsystem delivers to the primary loop.

For a large break analysis, a high head centrifugal charging pump starts and delivers flow through the injection lines (one for each loop) with one branch injection line spilling to the containment backpressure. To minimize delivery to the reactor, the branch line chosen to spill is selected as the one with the minimum resistance.

When the one low head residual heat removal pump starts, flow is delivered to the reactor coolant system through the 10-inch accumulator lines. One line, with minimum resistance, is spilling to the containment backpressure.

The following discussion of ECCS minimum safeguards is for breaks with an equivalent diameter less than a 10-inch accumulator line. For the high head centrifugal charging pump, the branch lines are 1-1/2 inches in diameter. Therefore, all small breaks with equivalent diameters less than the 1-1/2 inches will have a spilling line to RCS pressure and this flow will be considered lost to the break. In the case of a small break, less than the 10-inch accumulator line but greater than the 1-1/2-inch branch injection line, the charging pump will spill to the containment backpressure.

Therefore in the ECCS analyses done by Westinghouse, single failure is taken into account, i.e., loss of an RHR pump for large break or loss of one SI train for small break, and the spilling of the minimum resistance injection line. A break in an injection line is of the small break category.

Major Secondary System Pipe Break

The steam release arising from a break of a main steam pipe would result in energy removal from the RCS causing a reduction of coolant temperature and pressure. In the presence of a negative moderator temperature coefficient, the cooldown results in

a reduction of core shutdown margin. There is an increased possibility that the core will become critical and return to power. A return to power following a steam pipe break is a potential problem. The core is ultimately shut down by the boric acid injection delivered by the safety injection system.

The actual modeling of the safety injection system in MARVEL is described in WCAP-7909. The calculated transient delivery times for the borated water are listed in Table 15.1-1.

For the cases where offsite power is assumed, the sequence of events in the safety injection system is the following: after the generation of the safety injection signal (appropriate delays for instrumentation, logic, and signal transport included), the appropriate valves begin to operate and the high head safety injection pump starts. In 17 seconds, the valves are assumed to be in their final position and the pump is assumed to be at full speed. This does not include sequential transfer of high head safety injection pump suction from the VCT to the RWST. The additional 10 seconds for valves CV112B and C to close after CV112D and E are open has been evaluated and is consistent with the accident analysis results. Transfer of the pump suction would be completed in 27 seconds.

In cases where offsite power is not available, an additional 13-second delay is assumed to start the diesels and to load the necessary safety injection equipment onto them.

Results and Conclusions of Major Secondary System Pipe Break

The analysis has shown that even assuming a stuck rod cluster control assembly (RCCA) with or without offsite power, and assuming a single failure in the engineered safeguards the core remains in place and intact. Radiation doses will not exceed 10 CFR 50.67 guidelines.

Although DNB (with possible cladding perforation) following a steam pipe break are not necessarily unacceptable and not precluded in the criterion, the above analysis, in fact, shows that no DNB occurs for any rupture assuming the most reactive RCCA stuck in its fully withdrawn position.

Steam Generator Tube Rupture

The accident examined is the complete severance of a single steam generator tube assuming it takes place at power.

Assuming normal operation of the various plant control systems, the following sequence of events is initiated by a tube rupture:

- a. Pressurizer low-pressure and low-level alarms are actuated and charging pump flow increases in an attempt to maintain pressurizer level. On the secondary side, there is a steam flow/feedwater

flow mismatch before the trip as feedwater flow to the affected steam generator is reduced due to the additional break flow which is now being supplied to that unit.

- b. Continued loss of reactor coolant inventory leads to a reactor trip signal and safety injection generated by low-pressurizer pressure. The safety injection signal automatically terminates normal feedwater supply and initiates auxiliary feedwater addition. After reactor trip, the break flow reaches equilibrium at the point where incoming safety injection flow is balanced by outgoing break flow. The resultant break flow persists from plant trip for 30 to 60 minutes after the accident.
- c. The steam generator blowdown liquid monitor and the condenser off-gas radiation monitor will alarm, indicating a sharp increase in radioactivity in the secondary system and will automatically terminate steam generator blowdown.
- d. The reactor trip automatically trips the turbine; and if offsite power is available, the steam dump valves open permitting steam dump to the condenser. In the event of a coincident loss of offsite power, the steam dump valves would automatically close to protect the condenser. The steam generator pressure would rapidly increase resulting in steam discharge to the atmosphere through the steam generator safety and/or power-operated relief valves.
- e. Following reactor trip, the continued action of auxiliary feedwater supply and borated safety injection flow (supplied from the refueling water storage tank) provide a heat sink which absorbs some of the decay heat. Thus, steam bypass to the condenser or, in the case of loss of offsite power, steam relief to the atmosphere is attenuated during the period in which the recovery procedure leading to isolation is being carried out.
- f. Safety injection flow results in increasing pressurizer water level. The time after trip at which the operator can clearly see returning level in the pressurizer is dependent upon the amount of operating auxiliary equipment.

Results and Conclusions of a Steam Generator Tube Rupture

A steam generator tube rupture will cause no subsequent damage to the reactor coolant system or the reactor core. An orderly

recovery from the accident can be completed even assuming simultaneous loss of offsite power.

Existing Criteria Used to Judge the Adequacy of the ECCS

Criteria from 10 CFR 50.46:

- a. Peak cladding temperature calculated shall not exceed 2200°F.
- b. The calculated total oxidation of the cladding shall nowhere exceed 0.17 times the total cladding thickness before oxidation.
- c. The calculated total amount of hydrogen generated from the chemical reaction of the cladding with water or steam shall not exceed 0.01 times the hypothetical amount that would be generated if all of the metal in the cladding cylinders surrounding the fuel, excluding the cladding around the plenum volume, were to react.
- d. Calculated changes in core geometry shall be such that the core remains amenable to cooling.
- e. After any calculated successful initial operation of the ECCS, the calculated core temperature shall be maintained at an acceptable low value, and decay heat shall be removed for the extended period of time required by long-lived radioactivity remaining in the core.

In addition to, and as an extension of, the final acceptance criteria, two accidents have more specific criteria as described in the following.

In the case of the accidental depressurization of the main steam system additional criteria for adequacy of the ECCS are in assuming a stuck RCCA with offsite power available and assuming a single failure in the ESF, there will be no return to criticality after reactor trip for a steam release equivalent to the spurious opening with failure to close of the larger of a single steam dump, relief, or safety valve.

For a major secondary system pipe break, the added criteria are: assuming a stuck RCCA with or without offsite power and assuming a single failure in the engineered safeguards, the core remains in place and intact.

Inadvertent Operation of the ECCS During Pump Operation

A safety injection system signal (SIS) normally results in a reactor trip followed by a turbine trip. However, it cannot be assumed that any single spurious condition or fault that

actuates the SIS will also produce a reactor trip. Therefore, two different courses of events are considered:

- Case A Trip occurs at the same time spurious SIS starts, and
- Case B The reactor protection system produces a trip later in the transient.

In regards to Case B, the clearance of a spurious actuation of an SIS component, which does not also initially generate a system level SIS signal, would occur either as soon as appropriate operator action is taken to correct this spurious actuation or following a subsequent system level SIS occurrence which is discussed below.

Following a Case A spurious SIS, a permissive circuit prevents the operator from resetting the system level SIS until a timer, started by the SIS, times out (30 to 120 seconds) and until the reactor has tripped. When the operator is allowed by this permissive circuit to reset SIS, he would do so prior to the time at which procedures would require him to take over manual control of the components which were inadvertently stimulated by the spurious SIS signal. It is noted that resetting SIS does not by itself change the state of the components that may have been falsely stimulated. Reset simply makes the SIS signal go away.

Under an assumption that loss of offsite power occurred after such a reset, essential functions to bring the plant to safe shutdown would be automatic.

For example, after a system level SIS is reset, the emergency diesel generators, which had previously started by SIS, may be manually stopped. A subsequent loss of offsite power would cause the emergency diesel generators to start and the proper equipment for taking plant to safe shutdown (hot standby) would be loaded onto the diesel generators. For the maintenance of safe shutdown, the automatic operations would be supplemented by operator action.

Use of Dual Function Components

The ECCS contains components which have no other operating function as well as components which are shared with other systems. Components in each category are as follows:

- a. Components of the ECCS which perform no other function are:
 - 1. One accumulator for each loop which discharges borated water into its respective cold leg of the reactor coolant loop piping.

2. Two safety injection pumps, which supply borated water for core cooling to the RCS. (May be used during check valve testing also.)
 3. Associated piping, valves, and instrumentation.
- b. Components which also have a normal operating function are as follows:
1. The residual heat removal pumps and the residual heat exchangers: these components are normally used during the latter stages of normal reactor cooldown and when the reactor is held at cold shutdown for core decay heat removal. However, during all other plant operating periods, they are aligned to perform the low head injection function.
 2. The centrifugal charging pumps: these pumps are normally aligned for charging service. As a part of the chemical and volume control System, the normal operation of these pumps is discussed in Chapter 9.0.
 3. The refueling water storage tank: this tank is used to fill the refueling canal for refueling operations. However, during all other plant operating periods it is aligned to the suction of the safety injection pumps, and the residual heat removal pumps. The charging pumps are automatically aligned to the suction of the refueling water storage tank upon receipt of the safety injection signals since during normal operation they take suction from the volume control tank. (The containment spray pumps are also aligned to the suction of the refueling water storage tanks and upon receipt of a hi-3 containment pressure signal will pump water from the RWST to the spray rings.)

An evaluation of all components required for operation of the ECCS demonstrates that either:

- a. the component is not shared with other systems; or
- b. if the component is shared with other systems, it is either aligned during normal plant operation to perform its accident function or if not aligned to its accident function, two valves in parallel are provided to align the system for injection and two valves in series are provided to isolate portions of the system not utilized for injection. These valves are automatically actuated by the safety injection signal.

Table 6.3-8 indicates the alignment of components during normal operation and the realignment required to perform the accident function.

In all cases of component operation, safety injection has the priority usage such that an "S" signal will override all other signals and start or align systems for injection.

During a normal startup or shutdown, automatic SI actuation signals from low pressurizer pressure and low steamline pressure may be manually blocked.

If a steamline break occurs while both of these SI actuation signals are blocked, steamline isolation will occur on high negative steam pressure rate. An alarm for steamline isolation will alert the operator of the accident.

For large LOCAs, sufficient mass and energy would be released to the containment to automatically actuate SI when the containment high pressure setpoint is reached. At this time, the operator would be alerted to the occurrence of a LOCA by the following safety-related indications:

1. loss of pressurizer level,
2. rapid decrease of RCS pressure, and
3. increase in containment pressure.

In addition to the above, the following indications are normally available to the operator at the control board:

1. radiation alarms inside containment,
2. increase in floor drain sump water level,
3. decrease off scale of accumulator water levels and decrease in pressure,
4. ECCS valve and pump position and status light in ECCS energized indication, and annunciators light as safeguards equipment becomes energized, and
5. flow from ECCS pumps.

For very small LOCAs (approximately less than 2-inch diameter) in which the containment high pressure setpoint may not be reached, the operator would observe the safety-related indications plus the first two normally available indications. In addition, a charging flow/letdown mismatch would provide the operator with another indication of leakage from the RCS. Since the operator would observe the pressurizer level and

receive additional indications that a LOCA occurred, a manual SI would be initiated immediately. As presented in Reference 3 the time to uncover the core following a small break is relatively long (e.g., greater than 10 minutes for a 2-inch break). The operator would, therefore, have sufficient time to manually initiate SI.

Limits on System Parameters

The (ECCS) analysis shows that the design-basis performance characteristic of the ECCS is adequate to meet the requirements for core cooling following a LOCA with the minimum engineered safety feature equipment operating. In order to ensure this capability in the event of the simultaneous failure to operate any single active component, Technical Specifications are established for reactor operation.

Normal operating status of ECCS components is given in Table 6.3-9.

The ECCS components are available whenever the coolant energy is high and the reactor is critical. During low temperature physics tests there is a negligible amount of stored energy in the coolant and low decay heat; therefore, an accident comparable in severity to accidents occurring at operating conditions is not possible and ECCS components are not required.

The principal system parameters and the number of components which may be out of operation in test, quantities and concentrations of coolant available, and allowable time in a degraded status are illustrated in the Technical Specifications. If efforts to repair the faulty component are not successful, the plant is placed into a lower operational status, i.e., hot standby to hot shutdown, hot shutdown to cold shutdown, etc.

6.3.4 Tests and Inspections

6.3.4.1 ECCS Performance Tests

Preoperational Test Program at Ambient Conditions

The preoperational test program for the ECCS conforms to the recommendations of Regulatory Guides 1.68 and 1.79 and establishes proper flow requirements during cold conditions. The capability of the pumps to deliver required flows under accident conditions is then verified by analysis to preclude any unnecessary thermal shock damage at hot operating conditions. During the testing program, any unplanned or planned safety injection actuation is documented for further verification of flow capabilities. Check valve operability is conducted using guidelines and criteria established in Table 14.2-34.

Preliminary operational testing of the ECCS system is conducted during the hot functional testing of the reactor coolant system following flushing and hydrostatic testing with the system cold and the reactor vessel head removed. Provisions are made for excess water to drain into the refueling canal. The ECCS is aligned for normal power operation. Simultaneously, the safety injection block switch is reset, and the breakers on the lines supplying offsite power are tripped manually so that operation of the emergency diesels is tested in conjunction with the safety injection system. This test provides information including the following:

- a. satisfactory safety injection signal generation and transmission;
- b. proper operation of the emergency diesel-generators, including sequential load pickup;
- c. valve operating times;
- d. pump starting times; and
- e. pump delivery rates at runout conditions (one point on the operating curve).

Components

a. Pumps

Separate flow tests of the pumps in the ECCS systems are conducted during the operational startup testing (with the reactor vessel head off) to check proper runout flow rates, proper flow balancing in branch injection headers (high head pumps only), and capability for sustained operation. The centrifugal charging, safety injection, and residual heat removal pumps discharge into the reactor vessel through the injection lines; the overflow from the reactor vessel passes into the refueling canal. Each pump is tested separately with water drawn from the RWST. Data is taken to determine pump head and flow at this time. Pumps are then run on miniflow circuits and data taken to determine a second point on the head flow characteristic curve.

b. Accumulators

Each accumulator is filled with water from the RWST and pressurized with the MOV on the discharge line closed. Then the valve is opened and the accumulator allowed to discharge into the reactor vessel as part of the operational startup testing with the reactor cold and the vessel head off.

6.3.4.2 Reliability Tests and Inspections

Description of Tests Planned

Routine periodic testing is performed for ECCS components and all necessary support systems. Valves which must operate after a loss-of-coolant accident are operated through a complete cycle, and pumps are operated individually on their miniflow lines. If such testing indicates a need for corrective maintenance, the redundancy of equipment in these systems permits such maintenance to be performed without shutting down or reducing load under certain conditions. These conditions include considerations such as the period within which the component should be restored to service and the capability of the remaining equipment to provide the minimum required level of performance during such a period.

The operation of the remote stop valve and the check valve in each accumulator tank discharge line may be tested by opening the remote test line valves just downstream of the stop valve and check valve, respectively. Flow through the test line can be observed on instruments, and the opening and closing of the discharge line stop valve can be sensed on this instrumentation.

Where series check valves form the sole high-pressure to low-pressure isolation barrier between the reactor coolant system (RCS) and safety injection system (SIS) piping outside the reactor containment, periodic testing of these check valves is performed to provide assurance that certain postulated failure modes will not result in a loss of coolant from the low-pressure system outside containment with a simultaneous loss of safety injection pumping capacity.

The series check valves in the cold leg injection lines from the safety injection pumps and the residual heat removal pumps are in this category and require periodic testing. The remaining ECCS injection and recirculation lines employ a normally closed isolation valve for high-pressure to low-pressure isolation to ensure that a loss of coolant cannot occur in the low-pressure system outside containment. The capability is provided for periodic testing of the series check valves in these lines even though they are not susceptible to the same postulated failure modes that lead to a loss of coolant outside containment.

The SIS test line subsystem provides the capability for determination of the integrity of the pressure boundary formed by series check valves. The test performed verify that each of the series check valves can independently sustain differential pressure across its disc, and also verify that the valve is in its closed position. The required periodic tests are to be performed after each refueling just prior to plant startup, after the RCS has been pressurized.

The following check valves in the ECCS are provided with leak testing capability:

Group A	Group B
SI8949 A through D	SI8818 A through D
SI8905 A through D	SI8819 A through D
SI8900 A through D	SI8948 A through D
SI8841 A/B	SI8956 A through D
SI8815	

Periodic component testing requirements are contained in the Technical Specifications and the Technical Requirements Manual (TRM). During periodic system testing, a visual inspection of pump seals, valve packings, flanged connections, and relief valves is made to detect leakage. Inservice inspection provides further confirmation that no significant deterioration is occurring in the ECCS fluid boundary.

Design measures have been taken to ensure that the following testing can be performed:

- a. Active components may be tested periodically for operability (e.g., pumps on miniflow, certain valves, etc.).
- b. An integrated system actuation test (details of the testing of the sensors and logic circuits associated with the generation of a safety injection signal together with the application of this signal to the operation of each active component are given in Section 7.2) can be performed when the plant is cooled down and the residual heat removal system (RHRS) is in operation. The ECCS will be arranged so that no flow will be introduced into the RCS for this test.
- c. An initial flow test of the full operational sequence can be performed.

The design features which ensure this test capability are specifically:

- a. Power sources are provided to permit individual actuation of each active component of the ECCS.
- b. The safety injection pumps can be tested periodically during plant operation using the minimum flow recirculation lines provided.
- c. The residual heat removal pumps are used every time the RHRS is put into operation. They can also be

tested periodically when the plant is at power using the miniflow recirculation lines.

- d. The centrifugal charging pumps are either normally in use for charging service or can be tested periodically on miniflow.
- e. Remote-operated valves can be exercised during routine plant maintenance.
- f. Level and pressure instrumentation is provided for each accumulator tank for continuous monitoring of these parameters during plant operation.
- g. Flow from each accumulator tank can be directed through a test line to determine check valve leakage and to demonstrate operation of the accumulator motor-operated valves.
- h. A flow indicator is provided in the safety injection pump header and in the residual heat removal pump headers. Pressure instrumentation is also provided in these lines.
- i. An integrated system test can be performed when the plant is cooled down and the RHRS is in operation. This test does not introduce flow into the RCS but does demonstrate the operation of the valves, pump circuit breakers, and automatic circuitry including diesel starting and the automatic loading of ECCS components of the diesels (by simultaneously simulating a loss of offsite power to the vital electrical buses).

See the Technical Specifications and the TRM for the selection of test frequency, acceptability of testing, and measured parameters. ECCS components and systems are designed to meet the intent of ASME Code Section XI for inservice inspection.

6.3.5 Instrumentation Requirements

Instrumentation and associated analog and logic channels employed for initiation of emergency core cooling system (ECCS) operation is discussed in Section 7.3. The instrumentation readouts provided to the operator to enable him to perform required manual safety actions and to determine the effect of manual actions taken following reactor trip due to a Condition II, III, or IV event are listed in Table 7.5-1.

This section describes the instrumentation employed for monitoring ECCS components during normal plant operation and

also ECCS postaccident operation. All alarms are annunciated in the control room.

Measurement uncertainty for installed ECCS flow and pressure instrumentation is accounted for in the applicable 10CFR50.46 LOCA Safety Analysis in accordance with NUREG-1482 and ASME Section XI, OM-6 recommendations.

6.3.5.1 Temperature Indication

Cold Leg Injection/Normal RHR Return Line

Two temperature elements monitor the temperature of the coolant being returned to the RCS during SI and normal RHR loop operation via the RHR heat exchanger. Readout is on the control board.

Residual Heat Removal Heat Exchanger Inlet

The fluid temperature at the inlet of each RHR heat exchanger is recorded in the control room.

Residual Heat Removal Heat Exchanger Outlet

The temperature of the fluid leaving each RHR heat exchanger is indicated and recorded in the control room and monitored by a locally mounted temperature indicator.

6.3.5.2 Pressure Indication

Charging Pump Inlet and Discharge Pressure

There is a locally mounted pressure indicator located at the suction and discharge of each centrifugal charging pump.

Safety Injection Header Pressure

Safety injection pump discharge header pressure is indicated in the control room.

Suction of Safety Injection Pumps

There is a locally mounted pressure indicator at the suction of each safety injection pump.

Accumulator Pressure

Duplicate pressure channels are installed on each accumulator. Pressure indication in the control room and high- and low-pressure alarms are provided by each channel.

Test Line Pressure

A local pressure indicator used to check for proper seating of the accumulator check valves between the injection lines and the reactor coolant system (RCS) is installed on the leakage test line.

Residual Heat Removal Pump Inlet

A local pressure indicator is mounted at the inlet to each RHR pump.

Residual Heat Removal Pump Discharge Pressure

Residual heat removal discharge pressure for each pump is indicated in the control room. A high-pressure alarm is actuated by each channel.

6.3.5.3 Flow Indication

Charging Pump Injection Flow

Charging pump injection flow through the reactor cold leg is indicated in the control room.

Safety Injection Pump Header Flow

Flow through the safety injection pump header is indicated in the control room.

Test Line Flow

Local indication of the leakage test line flow is provided to check for proper seating of the accumulator check valves between the injection lines and the RCS.

Residual Heat Removal Return Line Flow

The return flow of reactor coolant from the residual heat removal loop during normal plant cooldown is recorded in the control room. This meter also controls the RHR bypass flow controller and alarms on low flow.

Safety Injection Pump Minimum Flow

A flow indicator is installed in the safety injection pump minimum flow line.

Residual Heat Removal Pump Minimum Flow

A flowmeter installed in each residual heat removal pump discharge header provides control for the valve located in the pump minimum flow line.

6.3.5.4 Level Indication

Containment Recirculation Sump Levels

The containment floor water level instrumentation (LT-PC006 and LT-PC007) provide indication for verification that sufficient recirculation water level exists prior to switchover to recirculation. Per a design basis calculation (Reference 5b), minimum recirculation water level is assured solely upon reaching the RWST level LO-2 alarm following a LOCA. The containment floor water level instrumentation provides reliable analog indication of containment floor water level in the control room and is environmentally qualified, safety-related, seismically mounted, and Regulatory Guide 1.97 Type 1 equipment. The containment floor water level instrumentation is available to diagnose a loss-of-coolant accident.

Drawings of the containment recirculation sump are provided in Figures 6.3-8a and 6.3-8b.

Refueling Water Storage Tank Level

Four water level instrumentation channels are provided for the refueling water storage tank. Each channel provides a high alarm, low alarm, LO-2 alarm, LO-3 alarm, and tank level indication in the main control room. Each alarm has a basis to ensure the ECCS and containment spray systems perform as designed. See Reference 4 for detailed calculations.

The RWST level high alarm protects against inadvertent overflowing of the RWST during normal operation.

The RWST level low alarm is provided to ensure that a sufficient volume of water is available in the RWST prior to a loss of coolant accident. The volume between the RWST high and low alarms provides for normal operating volume changes while providing margin to the minimum RWST level required by Technical Specifications for ECCS operations.

The RWST level LO-2 alarm setpoint is established to ensure the volume of RWST water injected from the low to the LO-2 alarms is sufficient to satisfy the following bases following a LOCA: (1) provide sufficient time prior to the first manual action required for switchover to recirculation following a LOCA, (2) adequate containment floor water level exists to provide water flow into the recirculation sumps to replace the water being pumped out by the RHR pumps following a LOCA. This will also ensure NPSH for the RHR pumps prior to switchover to recirculation, (3) sufficient RWST volume remains to complete ECCS switchover to recirculation mode prior to reaching the RWST empty level, (4) the core peak cladding temperature limit is not exceeded, and (5) sufficient borated water is provided to maintain reactor shutdown margin. The LO-2 alarm also alerts operators to enter the emergency procedure to realign the ECCS pumps from the cold leg injection mode to the cold leg recirculation mode following a LOCA and automatically opens the recirculation sump isolation valves (SI8811A/B) if an SI signal is present.

The RWST level LO-3 alarm alerts operators to initiate manual actions to transfer containment spray pump suction from the RWST to the recirculation sumps.

The RWST empty level is determined by reading the level indicators in the main control room. The specific RWST empty level value is given in the Emergency Operating Procedures. Upon reaching the RWST empty level, the RWST is not longer considered a reliable suction source for the ECCS and CS pumps following a LOCA. In the event the RWST empty level is reached due to multiple equipment failures and/or operator error, action should be taken to secure any ECCS and/or CS pumps not aligned to the recirculation sumps or RHR pump discharge, establish a recirculation flow path, and restart the pumps.

Accumulator Water Level

Duplicate water level channels are provided for each accumulator. Both channels provide indication in the control room and actuate high- and low-water level alarms.

6.3.5.5 Valve Position Indication

Valve positions which are indicated on the control board are done by a "normal off" system; i.e., should the valve not be in its proper position, a bright white light lights and gives a highly visible indication to the operator. Important valves will also have audible alarm in the control room.

For a list of manually operated valves with position indication in the control room, see Appendix 6.3A.

Accumulator Isolation Valve Position Indication

The accumulator motor-operated valves are provided with red (open) and green (closed) position indicating lights located at the control switch for each valve. These lights are powered by valve control power and actuated by valve motor-operated limit switches.

A monitor light that is on when the valve is not fully open is provided in an array of monitor lights that are all off when their respective valves are in proper position enabling safety operation. This light is energized from a separate monitor light supply and actuated by a valve motor-operated limit switch.

An alarm annunciator point is activated by both a valve motor operator limit switch and by a valve position limit switch activated by stem travel whenever an accumulator valve is not fully open for any reason with the system at pressure (the pressure at which the safety injection block is unblocked is approximately 1900 psig). A separate annunciator point is used for each accumulator valve. This alarm will be recycled at approximately 10 minute intervals to remind the operator of the improper valve lineup.

6.3.6 References

1. R. A. Hill, et. al., "Evaluation of Mispositioned ECCS Valves," WCAP-8966, September 1977.
2. Letter from C. Caso of Westinghouse to T. Novak of the NRC dated April 1, 1975.
3. R. Salvatori, "Westinghouse Emergency Core Cooling System - Plant Sensitivity Studies," WCAP-8356, July 1974.
4. Bryon/Braidwood Calculation SITH-1, "Refueling Water Storage Tank (RWST) Level Setpoints".
- 5a. Calculation BRW-06-0015-M/BYR06-025, "Design Loads and Sizing Limitations for the ECCS Containment Sump Trash Rack".
- 5b. Byron/Braidwood Calculation SI-90-01 "Minimum Water Volume Available for Containment Recirculation Sump Flooding".
- 5c. Calculation CAE-07-49/CCE-07-48, "Phase 2 Evaluation of Reduced SI Flow During Recirculation Phase of ECCS".

B/B-UFSAR

6. Letter from K.R. Jury (Exelon) to U.S. NRC document Control Desk, April 12, 2002.
7. NRC Generic Letter 2008-01, Managing Gas Accumulation in Emergency Core Cooling, Decay Heat Removal, and Containment Spray Systems, dated January 11, 2008.
8. U.S. Nuclear Regulatory Commission, "Information Report by the Office of Nuclear Reactor Regulation on the Single Failure Criterion," Commission Paper SECY 77-439, August 17, 1977 (ADAMS Accession No. ML060260236).
9. TSTF-523 Revision 2, Generic Letter 2008-01, Managing Gas Accumulation.
10. Letter from U.S. NRC to O.D. Kingsley (Commonwealth Edison Company), "Response to Generic Letter 95-07 - Braidwood Station, Units 1 and 2; and Byron Station, Units 1 and 2," dated December 2, 1999.

TABLE 6.3-1

EMERGENCY CORE COOLING SYSTEM
COMPONENT PARAMETERS

ACCUMULATORS

Number	4
Design pressure, psig	700
Design temperature, °F	300
Operating temperature, °F	100-150
Normal operating pressure, psig	640
Minimum operating pressure, psig	602
Total volume, ft ³	1350 each
Minimum water volume, ft ³	935
Volume N ₂ gas, ft ³	500
Boric acid concentration, nominal, ppm	2300
Boric acid concentration, minimum, ppm	2200
Relief valve setpoint, psig	700

CENTRIFUGAL CHARGING PUMPS

Number	2
Design pressure, psig	2800
Design temperature, °F	200
*Design flow rate, gpm	150
Design head, ft	5800
Max. flow rate, gpm	550
Head at max. flow rate, ft	1750
Discharge head at shutoff, ft	6000
**Motor rating, bhp	600
Maximum Required NPSH at 550 gpm (ECCS), ft	21 (Byron) 22 (Braidwood)
***Minimum Available NPSH, ft	33

* Includes miniflow.

** 1.15 service factor not included.

*** Minimum NPSHA based on maximum pump flow and pressure in the RWST below atmospheric pressure.

TABLE 6.3-1 (Cont'd)

SAFETY INJECTION PUMPS

Number	2
Design pressure, psig	1750**
Design temperature, °F	300
Design flow rate, gpm	400
Design head, ft	3000
Max. flow rate, gpm	655
Head at max. flow rate, ft	1890
Max. design discharge pressure, psig	1740
*Motor rating, bhp	500
Maximum Required NPSH at 655 gpm (ECCS), ft	28.8
***Minimum Available NPSH, ft	29.6

RESIDUAL HEAT REMOVAL PUMPS

(See Subsection 5.4.7 for design parameters)

RESIDUAL HEAT EXCHANGERS

(See Subsection 5.4.7 for design parameters)

* 1.15 Service factor not included.

** For the lines from the RWST to the charging pump and safety injection pump suction isolation valves (LCV-112 D/E; SI8806), the system design pressure is 50 psig. For the lines from the suction isolation valve (SI8806) to the safety injection pump suction flanges, the system design pressure is 240 psig. For the lines from the suction isolation valves (LCV-112 D/E) to the charging pump suction flanges, the system design pressure is 75 psig.

*** Minimum NPSHA based on maximum pump flow and pressure in the RWST below atmospheric pressure.

TABLE 6.3-1 (Cont'd)

VALVES

Motor-operated valves	Maximum expected stroke time*, sec
a. Up to and including 10 inches	15 (open or close)
b. 12 inches	20 (open or close)
c. SI8811A&B	100 (open only)
d. SI8801A&B	10 (open only)
e. CV112B&C	10 (close only)
f. CV8105 and CV8106	10 (close only)

* Actual valve stroke times may differ from those shown above provided that an evaluation is performed to determine the impact on applicable plant analyses (i.e., longer valve stroke time evaluated for impact on overall time required to complete switchover to cold leg recirculation mode). ECCS motor-operated valve stroke time acceptance criteria are controlled under the station Inservice Testing (IST) program. Any changes to valve stroke time acceptance criteria are evaluated per the station IST program requirements. Stroke times do not include signal response times of the engineered safeguards signal, which is assumed to add 2 seconds to the valve actuation time.

TABLE 6.3-2

ECCS RELIEF VALVES DATA

DESCRIPTION	FLUID DISCHARGE	FLUID INLET TEMPERATURE NORMAL	SET PRESSURE (psig)	BACK PRESSURE CONSTANT	BUILDING (psig)	CAPACITY
N ₂ supply to accumulators	N ₂	AMB	700	0	0	1500 scfm
Safety injection pump discharge	Water	100	1750†	3	50	20 gpm
Residual heat re- moval pump safety injection line	Water	114	600	3	50	400 gpm
Safety injection pumps suction header	Water	100	220	3	50	25 gpm
Accumulator to containment	Water or N ₂ Gas	120	700	0	0	1500 scfm
Residual heat removal pump suction header	Water	350	450	3	50	900 gpm
Containment recirculation sump isolation valve	Water	100	125	50	--	N/A*

* No specific relief capacity is required for this thermal relief valve.

† For Braidwood, the set pressure is 1810 psig.

TABLE 6.3-3

MOTOR-OPERATED ISOLATION VALVES IN ECCS

LOCATION	VALVE I.D.	INTERLOCKS	AUTOMATIC FEATURES	POSITION INDICATION	ALARMS
Accumulator isolation valves	SI8808 A,B,C,D	S, RCS pressure > unblock	Opens on S, RCS pressure > unblock	on MCB	Yes-out of position
SI pump suction from RWST	SI8806 SI8923 A&B	None None	None None	MCB MCB	Yes-out of position None
RHR suction from RWST	SI8812 A&B	Cannot be opened unless sump valve closed	None	MCB	None
RHR discharge to SI/CHRG pump suction	CV8804A SI8804B	Cannot be opened unless SI pump mini-flow isolated	None	MCB	None
SI HL injection	SI8802 A&B	None	None	MCB	None
RHR HL injection	SI8840	None	None	MCB	None
Containment sump isolation valve	SI8811 A&B	Opens on RWST LO-2 with S signal	Opens on RWST LO-2 level alarm with S signal	MCB	None
CVCS suction from RWST	LCV-112 D&E	Open on S	Open on S	MCB	None

TABLE 6.3-3 (Cont'd)

LOCATION	VALVE I.D.	INTERLOCKS	AUTOMATIC FEATURES	POSITION INDICATION	ALARMS
CVCS normal suction	LCV-112 B&C	Close on S	Close on S	MCB	None
SI pump to CL	SI8835	None	None	MCB	None
CVCS normal discharge	CV8105 CV8106	Closes on S	Closes on S	MCB	None
Charging and SI pump header from RHR	SI8807 A&B SI8924	None	None	MCB MCB	None None
RHR to RCS cold legs	SI8809 A&B	None	None	MCB	None
SI pump miniflow	SI8813 SI8814 SI8920	None	None	MCB MCB MCB	None None None
RHR cross-connect	RH8716 A&B	None	None	MCB	None
SI pump cross-connect	SI8821 A&B	None	None	MCB	None
CCP to RCS cold legs	SI8801 A&B	Open on S	Open on S	MCB	None

TABLE 6.3-4

MATERIALS EMPLOYED FOR
EMERGENCY CORE COOLING SYSTEM COMPONENTS

COMPONENT	MATERIAL
Accumulators	Carbon steel, clad with austenitic stainless steel
Pumps	
Centrifugal charging	Austenitic stainless steel
Safety injection	Austenitic stainless steel
Residual heat removal	Austenitic stainless steel
Residual heat exchangers	
Shell	Carbon steel
Shell end cap	Carbon steel
Tubes	Austenitic stainless steel
Channel	Austenitic stainless steel
Channel cover	Austenitic stainless steel
Tube sheet	Austenitic stainless steel
Valves	
Motor-operated valves containing radioactive fluids	
Pressure containing parts	Austenitic stainless steel or equivalent
Body-to-bonnet bolting and nuts	Low alloy steel
Seating surfaces	Stellite No. 6 or equivalent
Stems	Austenitic stainless steel or 17-4 PH stainless

TABLE 6.3-4 (Cont'd)

COMPONENT	MATERIAL
Motor-operated valves containing nonradioactive boron-free fluids	
Body, bonnet and flange	Carbon steel
Stems	Corrosion resistance steel
Diaphragm Valves	Austenitic stainless steel
Accumulator check valves	
Parts contacting borated water	Austenitic stainless steel
Clapper arm shaft	Inconel 718
Relief valves	
Stainless steel bodies	Stainless steel
Carbon steel bodies	Carbon steel
All nozzles, discs, spindles and guides	Austenitic stainless steel
Bonnets for stainless steel valves without a balancing bellows	Stainless steel or plated carbon steel
All other bonnets	Carbon steel
Piping	
All piping in contact with borated water	Austenitic stainless Steel
Containment Recirculation Sump Screen	Stainless Steel, type 304

TABLE 6.3-5

SINGLE ACTIVE FAILURE ANALYSIS FOR EMERGENCY CORE COOLING SYSTEM COMPONENTSSHORT-TERM PHASE

COMPONENTS	MALFUNCTION	COMMENTS
1. Pumps		
a. Centrifugal charging	Fails to start	Two provided; evaluation based on operation of one.
b. Safety injection	Fails to start	Two provided; evaluation based on operation of one.
c. Residual heat removal	Fails to start	Two provided; evaluation based on operation of one.
2. Automatically operated valves		
a. Residual heat removal pumps suction line to containment sump	Fails to open	Two parallel lines; only one valve in either line required to open.
b. Centrifugal Charging Pumps		
(1) Suction line to refueling water storage tank	Fails to open	Two parallel lines; only one valve in either line required to open.
(2) Discharge line to the normal charging path	Fails to close	Two parallel in series; only one valve required to close.
(3) Miniflow bypass line	Fails to close	Two valves in series; only one valve required to close.

TABLE 6.3-5 (Cont'd)

COMPONENT	MALFUNCTION	COMMENTS
(4) Suction from volume control tank	Fails to close	Two valves in series; only one valve required to close.
(5) Discharge line to RCS cold legs	Fails to open	Two parallel lines; only one valve required to open.
<u>LONG-TERM PHASE</u>		
COMPONENT	MALFUNCTION	COMMENTS
1. Valves operated manually from the control room		
a. Residual heat removal pumps suction line from refueling water storage tank	Fails to close	Check valve in series with one gate valve; operation of only one valve required.
b. Safety injection pump suction line from refueling water storage tank	Fails to close	Check valve in series with gate valve; operation of only one valve required.
c. Centrifugal charging pump suction line from refueling water storage tank	Fails to close	Check valve in series with two parallel gate valves; operation of the gate valves required.
d. High head pump suction line at discharge of residual heat exchanger	Fails to open	Separate and independent high head injection paths to safety injection pumps and charging pumps taking suction from discharge of residual heat exchangers; operation of only one valve required.

TABLE 6.3-5 (Cont'd)

COMPONENT	MALFUNCTION	COMMENTS
e. Residual heat removal cross-connect line	Fails to close	Two valves in series; operation of one required.
f. Safety injection pump miniflow lines	Fails to close	Two parallel valves provided in series with a third; operation of either both parallel valves or series valve required.
g. Safety injection/charging cross-connect line in suction header	Fails to open	Two parallel valves provided; operation of either one required.
h. Safety injection/residual heat removal cold leg isolation valves	Fails to open	Three flow paths available. Adequate flow to core is assured by any two.
I. Safety injection/residual heat removal cold leg isolation valves	Fails to close	Redundant valves provided with suitable arrangements to preclude pump runout.

TABLE 6.3-6

EMERGENCY CORE COOLING SYSTEM RECIRCULATION PIPING PASSIVE FAILURE ANALYSISLONG-TERM PHASE

<u>FLOW PATH</u>	<u>INDICATION OF LOSS OF FLOW PATH</u>	<u>ALTERNATE FLOW PATH</u>
From containment sump to low head injection header via the residual heat removal pumps and the residual heat exchangers.	Accumulation of water in a residual heat removal pump compartment or auxiliary building sump.	Via the independent, identical low head flow path utilizing the second residual heat exchanger and residual heat removal pump
<u>HIGH HEAD RECIRCULATION</u>		
From containment sump to the high head injection header via residual heat removal pump residual heat exchanger and the high head injection pumps.	Accumulation of water in a residual heat removal pump compartment or the auxiliary building sump or safety injection or charging pump compartments.	From containment sump to the high head injection headers via alternate residual heat removal pump, residual heat exchanger, safety injection, or charging pump.

TABLE 6.3-7

SEQUENCE OF SWITCHOVER OPERATIONS(BASED ON NO SINGLE FAILURES)SWITCHOVER FROM INJECTION TO COLD LEG RECIRCULATION

The following subsections outline the major automatic and manual operator actions required to complete switchover from ECCS cold leg injection mode to cold leg recirculation mode following a LOCA. During the cold leg injection mode and prior to receipt of the RWST level LO-2 alarm, the operator is diagnosing the accident and verifying safety system actuation. Upon receipt of the RWST level LO-2 alarm, the following actions are performed without delay. Manual actions one through six function to align the suction of the residual heat removal pumps to the containment recirculation sumps and to align the suction of the charging and safety injection pumps to the discharge of the residual heat removal pumps, thereby assuring a long term suction source for all ECCS pumps.

MAJOR STEPS FOR SWITCHOVER TO COLD LEG RECIRCULATION⁽¹⁾

The RWST level LO-2 alarm signal in conjunction with a SI signal automatically initiates opening of the containment recirculation sump isolation valves (SI8811A&B). Upon receipt of the RWST level LO-2 alarm, the operator enters the switchover to cold leg recirculation emergency operating procedure, establishes/verifies component cooling water flow to the RHR heat exchangers, verifies adequate containment recirculation sump level and performs the following actions (Refer to emergency operating procedure B(w)EP ES-1.3 "Transfer to Cold Leg Recirculation" for a description of all steps, notes, and cautions):

- Steps 1: When each containment recirculation sump isolation valve (SI8811A&B) has reached the fully open position, close the RWST to RHR pump suction isolation valves (SI8812A&B). Closing the SI8812A&B valves after the SI8811A&B valves open increases available switchover time by preventing gravity backflow from the RWST to the recirculation sumps and stopping RHR pump outflow from the RWST.
- Step 2: Verify/close CV pump miniflow valves (CV8110, CV8111, CV8114, and CV8116).
- Step 3: Close the three SI pump miniflow valves (SI8813, SI8814, and SI8920). If power has not been restored to the SI8813 valve, continue to the next step and close the SI8813 valve when power is restored.

TABLE 6.3-7 (Cont'd)

- Step 4: Close the RHR heat exchanger discharge crosstie valves (RH8716A&B)
- Step 5: Open the SI and CV pump suction header crosstie valves (SI8807A, SI8807B) and verify open valve SI8924.
- Step 6: If the associated train RHR pump is running, open the valve from the RH pump discharge line to the CV pump suction isolation valve and to the SI pump suction isolation valve (CV8804A and SI8804B) respectively.

Upon completion of Step 6, the ECCS is aligned for cold leg recirculation mode of operation with both RHR pumps delivering flow from the containment recirculation sump directly to the RCS cold legs (if RCS pressure is less than RHR pump shutoff head) and also delivering flow to the suction of the CV and SI pumps. Both CV and SI pumps are also delivering flow to the RCS cold legs.

MAJOR STEPS TO ESTABLISH REDUNDANT ISOLATION OF THE RECIRCULATING SUMP WATER FROM THE RWST:

Completion of the following manual actions are required to establish redundant isolation of the recirculating sump water from the RWST. These steps ensure a single valve failure (either check valve or motor-operated valve) will not result in pumping contaminated recirculation sump water to the RWST and decrease ECCS flow to the reactor vessel:

- Step 1: Restore power to and close the RWST to SI pumps suction isolation valve (SI8806). If power has not been restored to the SI8806 valve, continue to the next step and close the SI8806 valve when power is restored.
- Step 2: Close the RWST to CV pump suction valves (CV112D&E)

MAJOR STEPS FOR CONTAINMENT SPRAY PUMP SWITCHOVER FROM THE RWST TO THE CONTAINMENT RECIRCULATION SUMPS:

Containment spray pump switchover to the recirculation sumps is initiated upon receipt to the RWST level LO-3 alarm. Upon completion of the following manual actions, the containment spray pumps will have a long term suction source from the containment recirculation sumps:

- Step 1: Open CS pump sump suction valves (CS009A&B)
- Step 2: Close CS pump RWST suction valves (CS001A&B)

TABLE 6.3-7 (Cont'd)

The actions stated above only outline major procedural steps required for switchover of ECCS and CS pumps to the recirculation mode of operation and providing redundant isolation of the RWST from the recirculating sump water. Refer to B(w)EP ES-1.3 for the exact description and sequence of all procedural steps, notes, and cautions required for proper ECCS system operation during switchover to cold leg recirculation.

SWITCHOVER FROM COLD LEG RECIRCULATION TO HOT LEG RECIRCULATION

At approximately 6.0 hours after the accident, hot leg recirculation shall be initiated. The following manual operator actions are normally performed to complete the switchover operation from the cold leg recirculation mode to the hot leg recirculation mode.

SWITCHOVER STEPS

STEP 1: Close residual heat removal pump discharge cold leg header isolation valves SI8809 A&B.

STEP 2: Open residual heat removal pump discharge crossover isolation valve RH8716 A.

TABLE 6.3-7 (Cont'd)

- STEP 3: Open the residual heat removal pump discharge hot leg header isolation valve (SI8840).
- STEP 4: Stop safety injection pump A.
- STEP 5: Close the corresponding safety injection pump discharge crossover header isolation valve (SI8821A).
- STEP 6: Open the corresponding safety injection pump discharge hot leg header isolation valve (SI8802A).
- STEP 7: Restart safety injection pump A.
- STEP 8: Stop safety injection pump B.
- STEP 9: Close the corresponding safety injection pump discharge crossover isolation valve (SI8821B).
- STEP 10: Open the corresponding safety injection pump discharge hot leg header isolation valve (SI8802B).
- STEP 11: Restart safety injection pump B.
- STEP 12: Close the safety injection pump discharge cold leg header isolation valve (SI8835).

The ECCS is now aligned for hot leg recirculation as follows:

- a. Both residual heat removal pumps are delivering from the containment sump directly to the RCS hot legs and are also delivering to the suction of the safety injection and charging pumps.
- b. Both safety injection pumps are delivering to the RCS hot legs.
- c. Both charging pumps are delivering to the RCS cold legs.

NOTES:

- (1) The operator actions for switchover from injection to cold leg recirculation are not to be interrupted until all of the steps in the switchover are completed; however, if the RWST empty level is reached anytime during the switchover, immediately stop any pumps that are not either aligned to the recirculation sump or RH pump discharge, then complete the switchover and restart any pump which was stopped, starting with the residual heat removal pump.

TABLE 6.3-8

EMERGENCY CORE COOLING SYSTEM SHARED FUNCTIONS EVALUATION

COMPONENT	NORMAL OPERATING ARRANGEMENT	ACCIDENT ARRANGEMENT
Refueling water storage tank	Lined up to suction of safety injection and residual heat removal pumps	Lined up to suction of centrifugal charging, safety injection and residual heat removal pumps.
Centrifugal charging pumps	Lined up for charging service.	Lined for injection. Valves for realignment meet single failure criteria.
Residual heat removal pumps	Lined up to cold legs of reactor coolant piping.	Lined up to cold legs of reactor coolant piping.
Residual heat exchangers	Lined up to cold legs of reactor coolant piping.	Lined up to cold legs of reactor coolant piping.

TABLE 6.3-9

NORMAL OPERATING STATUS OF EMERGENCY CORE COOLINGSYSTEM COMPONENTS FOR CORE COOLING¹

Number of safety injection pumps operable	2
Number of charging pumps operable	2
Number of residual heat removal pumps operable	2
Number of residual heat exchangers operable	2
Minimum Refueling water storage tank volume, gal	407,000
Boron concentration in refueling water storage tanks, nominal, ppm	2,400
Boron concentration in accumulator, minimum, ppm	2,200
Number of accumulators	4
Minimum accumulator pressure, psig	602
Minimum accumulator water volume, ft ³	935
System valves, interlocks, and piping required for the above components which are operable	All

¹ See Technical Specifications for all exceptions.

B/B-USFAR

TABLE 6.3-10

FAILURE MODE AND EFFECTS ANALYSIS - EMERGENCY CORE
COOLING SYSTEM - ACTIVE COMPONENTS

COMPONENT	FAILURE MODE	ECCS OPERATION PHASE	*EFFECT ON SYSTEM OPERATION	**FAILURE DETECTION METHOD	REMARKS
1. Motor-operated gate valve 1/2CV112B (1/2CV112C analogous).	Fails to close on demand.	Injection - cold legs of RC loops.	Failure reduces redundancy providing VCT discharge isolation. No effect on safety for system operation; isolation valves 1/2CV112C and 1/2CV8440 provides backup tank discharge isolation.	Valve position indication (open to closed position change) at MCB. Valve closed position monitor light for group monitoring of components at MCB.	Valve is electrically interlocked with isolation valve 1/2CV112D. Valve closes on actuation by a SI "S" signal providing isolation valve 1/2CV112D is at a full open position.
2. Motor-operated gate valve 1/2CV112D (1/2CV112E analogous).	Fails to open on demand.	Injection - cold legs of RC loops.	Failure reduces redundancy of providing fluid flow from RWST to suction of CV pumps. No effect on safety for system operation. Alternate isolation valve (1/2CV112E) opens to provide backup flow path to suction of CV pumps.	Valve position indication (closed to open position change) at MCB. Valve open position monitor light for group monitoring of components at MCB.	Valve is electrically interlocked with the instrumentation that monitors fluid level of the VCT. Valve opens upon actuation by a SI "S" signal or upon actuation by a LO-2 level VCT signal.

* See list at end of table for definition of acronyms and abbreviations used.

**As part of plant operation, periodic tests, surveillance inspections and instrument calibrations are made to monitor equipment and performance. Failure may be detected during such monitoring of equipment in addition to detection methods noted.

B/B-USFAR

TABLE 6.3-10 (Cont'd)

COMPONENT	FAILURE MODE	ECCS OPERATION PHASE	EFFECT ON SYSTEM OPERATION	FAILURE DETECTION METHOD	REMARKS
3. Centrifugal charging pump A, (pump B analogous).	Fails to deliver working fluid.	Injection and Recirculation - cold legs of RC loops.	Failure reduces redundancy of providing emergency coolant to the RCS at prevailing incident RCS pressure. Fluid flow from CV pump A will be lost. Minimum flow requirements at prevailing high RCS pressures will be met by CV pump B delivery.	CV pump discharge header flow (FT-3A) at MCB. Open pump switchgear circuit breaker indication at MCB. Pump running monitor light for group monitoring of components at MCB. Common breaker trip alarm at MCB.	One CV pump used for normal charging of RCS during plant operation. Pump circuit breaker aligned to close on actuation by a SI "S" signal.
4. Motor-operated globe valve Pump A: 1/2CV8111 (1/2CV8114 analogous), Pump B: 1/2CV8110 (1/2CV8116 analogous).	Fails to close on demand.	Injection - cold legs of RC loops.	Failure reduces redundancy of providing isolation of CV pump miniflow line. No effect on safety for system operation. Alternate isolation valve 1/2CV8114 (Pump A) / 1/2CV8116 (Pump B) in miniflow line provides backup isolation.	Same methods of detection as those stated for item #1. In addition, valve close position alarm for 1/2CV8114 and 1/2CV8116 at MCB.	Valve aligned to close upon actuation by a SI "S" signal in conjunction with RWST LO-2 level.

B/B-USFAR

TABLE 6.3-10 (Cont'd)

COMPONENT	FAILURE MODE	ECCS OPERATION PHASE	EFFECT ON SYSTEM OPERATION	FAILURE DETECTION METHOD	REMARKS
5. Motor-operated gate valve 1/2CV8105 (1/2CV8106 analogous).	Fails to close on demand.	Injection - cold legs of RC loops.	Failure reduces redundancy of providing isolation of CV pump discharge to normal charging line of CVCS. No effect on safety for system operation. Alternate valve 1/2CV8106 provides backup normal CVCS charging line isolation.	Same methods of detection as those stated for item #1.	Valve aligned to close upon actuation by a SI "S" signal.
6. Motor-operated gate valve 1/2SI8801A (1/2SI8801B analogous).	Fails to open on demand.	Injection - cold legs of RC loops.	Failure reduces redundancy of fluid flow paths from CV pumps to the RCS. No effect on safety for system operation. Alternate isolation valve 1/2SI8801B opens to provide backup flow path from CV pumps.	Same methods of detection as those stated for item #2.	Valve aligned to open upon actuation by a SI "S" signal.
7. Motor-operated gate valve 1/2RH610 (1/2RH611 analogous).	a. Fails to close on demand.	Injection - cold legs of RC loops.	a. Failure reduces work fluid delivered to RCS from RHR pump A. Minimum flow requirements for	a. Valve position indication (open to closed position change) at MCB. RHR pump discharge	Valve is regulated by signal from flow transmitter located in pump discharge header. The control valve

B/B-USFAR

TABLE 6.3-10 (Cont'd)

COMPONENT	FAILURE MODE	ECCS OPERATION PHASE	EFFECT ON SYSTEM OPERATION	FAILURE DETECTION METHOD	REMARKS
	b. Fails closed	Injection - cold legs of RC loops.	b. Failure results in an insufficient fluid flow through RHR pump A for a small LOCA or steam line break resulting in possible pump damage. If pump becomes inoperative minimum flow requirements for injection will be met by RHR pump B delivering working fluid to RCS.	flow (FI-618) at MCB.	opens when the pump discharge flow is less than 750 gpm and closes when the flow exceeds 1400 gpm when the valve MCB control switch is in the Auto position.
8. Residual heat removal pump A, (Pump B analogous).	Fails to deliver working fluid.	Injection - cold legs of RC loops.	Failure reduces redundancy of providing emergency coolant to the RCS from the RWST at low RCS pressure. Fluid flow from pump	RHR pump discharge flow (FI-618) and low flow alarm at MCB. RHR pump discharge pressure (PI-614) at MCB. Open pump switchgear	The RHR pump is sized to deliver reactor coolant through the RHR heat exchanger to meet plant cooldown require-

B/B-USFAR

TABLE 6.3-10 (Cont'd)

COMPONENT	FAILURE MODE	ECCS OPERATION PHASE	EFFECT ON SYSTEM OPERATION	FAILURE DETECTION METHOD	REMARKS
			A will be lost. Minimum flow requirements for injection will be met by RHR pump B delivering working fluid.	circuit breaker indication at MCB. Pump running monitor light for group monitoring of components at MCB. Common breaker trip alarm at MCB.	ments and is used during plant cooldown and startup operations. The pump circuit breaker is aligned to close on actuation by SI "S" signal.
9. Safety injection pump A, (Pump B analogous).	Fails to deliver working fluid.	Injection - cold legs of RC loops.	Failure reduces redundancy of providing emergency coolant to the RCS from the RWST at high RCS pressure. Fluid flow from SI pump A will be lost. Minimum flow requirements for injection will be met by SI pump B delivering working fluid.	SI pumps discharge pressure (PI-919) at MCB. SI pump discharge flow (PI-918) at MCB. Open pump switchgear circuit breaker indication at MCB. Pump running monitor light for group monitoring of components at MCB. Common breaker trip alarm at MCB.	Pump circuit breaker aligned to close on actuation by a SI "S" signal.
10. Motor-operated gate valve 1/2SI8811A (1/2SI8811B analogous).	Fails to open on demand.	Recirculation - cold legs of RC loops.	Failure reduces redundancy of providing fluid from the containment sump to the RCS during recirculation. RHR pump A will not provide recirculation flow. Minimum injection flow requirements	Same methods of detection as those stated for item #2. In addition, failure may be detected through monitoring of RHR pump flow (FI-618) and RHR pump discharge	Valve is actuated to open by SI "S" signal in coincidence with two-out-of-four LO-2 level RWST signals. Valve is electrically interlocked from

B/B-USFAR

TABLE 6.3-10 (Cont'd)

COMPONENT	FAILURE MODE	ECCS OPERATION PHASE	EFFECT ON SYSTEM OPERATION	FAILURE DETECTION METHOD	REMARKS
			will be met through opening of isolation valve 1/2SI8811B and recirculation of fluid by RHR pump B.	pressure (PI-614) at MCB.	manually being opened from MCB by 1/2SI8812A, 1/2RH8701A and 1/2RH8701B. (For B train: 1/2SI8812B, 1/2RH8702A, 1/2RH8702B)
11. Motor-operated gate valve 1/2SI8812A (1/2SI8812B analogous).	Fails to close on demand.	Recirculation - cold legs of RC loops.	Failure reduces redundancy of providing flow isolation from RWST to containment sump. No effect on safety for system operation. Alternate check isolation valve 1/2SI8958A provides backup isolation.	Same methods of detection as those stated for item #1.	Valve is electronically interlocked with valve 1/2SI8811A. It may not be manually opened from MCB unless valve 1/2SI8811A is closed.
12. Motor-operated gate valve 1/2RH8716A (1/2RH8716B analogous).	Fails to close on demand.	Recirculation - cold legs of RC loops.	Failure reduces redundancy of providing RHR pump train separation for recirculation of fluids to cold legs of RCS. No effect on safety for system operation. Alternate isolation valve 1/2RH8716B provides backup isolation for RHR pump train separation.	Same methods of detection as those stated for item #1.	

B/B-USFAR

TABLE 6.3-10 (Cont'd)

COMPONENT	FAILURE MODE	ECCS OPERATION PHASE	EFFECT ON SYSTEM OPERATION	FAILURE DETECTION METHOD	REMARKS
13. Motor-operated globe valve 1/2SI8813.	Fails to close on demand.	Recirculation - cold legs of RC loops.	Failure reduces redundancy providing isolation of SI pump's miniflow line from RWST. No effect on safety for system operation. Alternate isolation valve 1/2SI8814 (Pump A) and 1/2SI8920 (Pump B) in each pump's miniflow line provide backup isolation.	Same methods of detection as those stated for item #1.	
14. Motor-operated globe valve 1/2SI8814 (1/2SI8920 analogous).	Fails to close on demand.	Recirculation - cold legs of RC loops.	Failure reduces redundancy of providing isolation of SI pump A miniflow isolation from RWST. No effect on safety for system operation. Alternate isolation valve 1/2SI8813 in main miniflow line provides backup isolation.	Same methods of detection as those stated for item #1.	
15. Motor-operated gate valve 1/2SI8807A (1/2SI8807B analogous).	Fails to open on demand.	Recirculation - cold legs of RC loops.	Failure reduces redundancy of providing fluid flow through cross-tie between suction of CV pumps and SI pumps. No effect on safety for system	Same methods of detection as those stated for item #2.	

B/B-USFAR

TABLE 6.3-10 (Cont'd)

COMPONENT	FAILURE MODE	ECCS OPERATION PHASE	EFFECT ON SYSTEM OPERATION	FAILURE DETECTION METHOD	REMARKS
			operation. Alternate isolation valve 1/2SI8807B opens to provide backup flow path through cross-tie line.		
16. Motor-operated gate valve 1/2SI8806.	Fails to close on demand.	Recirculation - cold legs of RC loops.	Failure reduces redundancy of providing flow isolation of SI pump suction from RWST. No effect on safety for system operation. Alternate check isolation valve 1/2SI8926 provides backup isolation.	Same methods of detection as those stated for item #1.	
17. Motor-operated gate valve 1/2CV112D (1/2CV112E analogous).	Fails to close on demand.	Recirculation - cold legs of RC loops.	Failure reduces redundancy of providing flow isolation of suction of CV pumps from RWST. No effect on safety for system operation. Alternate check isolation valve 1/2CV8546 provides backup isolation.	Same methods of detection as those stated for item #1.	
18. Residual heat removal pump A, (pump B)	Fails to deliver working fluid.	Recirculation - cold legs of RC loops.	Failure reduces redundancy of providing recirculation of	Same methods of detection as those stated for item #8.	

B/B-USFAR

TABLE 6.3-10 (Cont'd)

COMPONENT	FAILURE MODE	ECCS OPERATION PHASE	EFFECT ON SYSTEM OPERATION	FAILURE DETECTION METHOD	REMARKS
analogous).			coolant to the RCS from the Containment Sump. Fluid flow from RHR pump A will be lost. Minimum recirculation flow requirements for injection flow will be met by RHR pump B delivering working fluid.		
19. Safety injection pump A, (pump B analogous).	Fails to deliver working fluid.	Recirculation - cold or hot legs of RC loops.	Failure reduces redundancy of providing recirculation of coolant to the RCS from the Containment Sump via RHR and SI pumps. Fluid flow from SI pump A will be lost. Minimum recirculation flow requirements for injection flow will be met by SI pump B delivering working fluid.	Same methods of detection as those stated for item #9.	
20. Motor-operated gate valve 1/2SI8809A.	Fails to close on demand.	Recirculation - hot legs of RC loops.	Failure reduces redundancy of providing recirculation of coolant to the RCS from the Containment Sump to hot legs of RC loops. Fluid flow from RHR pump A	Same methods of detection as those stated for item #1.	

B/B-USFAR

TABLE 6.3-10 (Cont'd)

COMPONENT	FAILURE MODE	ECCS OPERATION PHASE	EFFECT ON SYSTEM OPERATION	FAILURE DETECTION METHOD	REMARKS
21. Motor-operated gate valve 1/2RH8716A.	Fails to open on demand.	Recirculation - hot legs of RC loops.	will continue to flow to cold legs of RC loops. Minimum recirculation flow requirements to hot legs of RC loops will be met by RHR pump B recirculation fluid to RC hot legs via SI pumps.	Same methods of detection as those stated for item #2. In addition, RHR pump discharge pressure (PI-614) at MCB.	

B/B-USFAR

TABLE 6.3-10 (Cont'd)

COMPONENT	FAILURE MODE	ECCS OPERATION PHASE	EFFECT ON SYSTEM OPERATION	FAILURE DETECTION METHOD	REMARKS
22. Motor-operated gate valve 1/2SI8840.	Fails to open on demand.	Recirculation - hot legs of RC loops.	Failure reduces redundancy of providing recirculation of coolant to the hot legs of RCS from the containment sump via RHR pumps. Minimum recirculating flow requirements to the hot legs of RC loops will be met by RHR pump(s) recirculating fluid via the SI pump(s) to hot legs of RC loops.	Same methods of detection as those stated for item #2. In addition, RHR pump discharge pressure (PI-614) at MCB.	

B/B-USFAR

TABLE 6.3-10 (Cont'd)

COMPONENT	FAILURE MODE	ECCS OPERATION PHASE	EFFECT ON SYSTEM OPERATION	FAILURE DETECTION METHOD	REMARKS
23. Motor-operated gate valve 1/2SI8809B.	Fails to close on demand.	Recirculation - hot legs of RC loops.	Failure reduces redundancy of providing recirculation of coolant to the RCS from the Containment Sump to hot legs of RC loops. Fluid flow from RHR pump B will continue to flow to cold legs of RC loops. Minimum recirculation flow requirements to hot legs of RC loops will be met by RHR pump A recirculating fluid to RC hot legs via the SI pump(s).	Same methods of detection as those stated for item #1.	
24. Motor-operated gate valve 1/2SI8821A (1/2SI8821B analogous).	Fails to close on demand.	Recirculation - hot legs of RC loops.	Failure reduces redundancy of providing flow isolation of SI pump flow to cold legs of RC loops. No effect on safety for system operation. Alternate isolation valve 1/2SI8835 provides backup isolation against flow to cold legs of RC loops.	Same method of detection as that stated for item #1.	

B/B-USFAR

TABLE 6.3-10 (Cont'd)

COMPONENT	FAILURE MODE	ECCS OPERATION PHASE	EFFECT ON SYSTEM OPERATION	FAILURE DETECTION METHOD	REMARKS
25. Motor-operated gate valve 1/2SI8802A (1/2SI8802B analogous).	Fails to open on demand.	Recirculation - hot legs of RC loops.	Failure reduces redundancy of providing recirculation of coolant to the hot legs of RCS from the Containment Sump via SI pumps. Minimum recirculating flow requirements to hot legs of RC loops will be met by SI pump B.	Same methods of detection as those stated for item #2. In addition, SI pump discharge pressure (PI-919) and flow (FI-918) indications at MCB.	
26. Motor-operated gate valve 1/2SI8835.	Fails to close on demand.	Recirculation - hot legs of RC loops.	Failure reduces redundancy of providing flow isolation of SI pump flow to cold legs of RC loops. No effect on safety for system operation. Alternate isolation valves 1/2SI8821A and 1/2SI8821B in cross-tie line between SI pumps provides backup isolation against flow to cold legs of RC loops.	Same methods of detection as that stated for item #1.	

B/B-USFAR

TABLE 6.3-10 (Cont'd)

COMPONENT	FAILURE MODE	ECCS OPERATION PHASE	EFFECT ON SYSTEM OPERATION	FAILURE DETECTION METHOD	REMARKS
27. Residual heat removal pump A, (pump B analogous).	Fails to deliver working fluid.	Recirculation - hot legs of RC loops.	Failure reduced redundancy of providing recirculation of coolant to the RCS from the Containment Sump to the hot legs of RC loops. Fluid flow from RHR pump A will be lost. Minimum flow requirements to hot legs of RC loop will be met by RHR pump B recirculation fluid to RC hot legs via SI pumps.	Same method of detection as those stated for item #8.	
28. Thermal relief valve 1/2SI121A (1/2SI121B analogous)	Fails to open	Recirculation - cold legs of RC loops	Failure could render 1/2SI8811A inoperable (fails to open) due to pressure locking. Effect on system operation is the same as Item 10 above.		Valve set to open at 75 psid
	Fails to close	Recirculation - cold legs of RC loops	Eliminates 1/2SI8811A pressure locking concern.		

B/B-UFSAR

TABLE 6.3-10 (Cont'd)

LIST OF ABBREVIATIONS AND ACRONYMS

CV	- Chemical and Volume Control
LOCA	- Loss-of-Coolant Accident
MCB	- Main Control Board
RC	- Reactor Coolant
RCS	- Reactor Coolant System
RHR	- Residual Heat Removal
RWST	- Refueling Water Storage Tank
SI	- Safety Injection
VCT	- Volume Control Tank

B/B-UFSAR

TABLE 6.3-11

ECCS ACTIVE COMPONENTS

VALVE LOCATION NUMBER	SYSTEM	TYPE/ANS SAFETY CLASS	SEISMIC DESIGN CLASSIFICATION (1)	ACTUATED BY	SERVICES (2)
121 A/B	SIS	Relief/2	I	ΔP	--
8900 A/B/C/D	SIS	Check/1	I ⁽¹⁾	ΔP	--
8815	SIS	Check/1	I	ΔP	--
8801 A/B	SIS	Gate/2	I	Motor	Electrical Train A/B
8843	SIS	Globe/2	I	Air	Electrical Train N/A
8807 A/B	SIS	Gate/2	I	Motor	Electrical Train A/B
8924	SIS	Gate/2	I	Motor	Electrical Train B
8964	SIS	Globe/2	I	Air	Electrical Train B
8871	SIS	Globe/2	I	Air	Electrical Train A
8948 A/B/C/D	SIS	Check/1	I	ΔP	--
8956 A/B/C/D	SIS	Check/1	I	ΔP	--
8808 A/B/C/D	SIS	Gate/1	I	Motor	Electrical Train A/B/B/A
8968	SIS	Check/2	I	ΔP	--
8880	SIS	Globe/2	I	Air	Electrical Train A
8949 A/B/C/D	SIS	Check/1	I	ΔP	--
8841 A/B	SIS	Check/1	I	ΔP	--
8905 A/B/C/D	SIS	Check/1	I	ΔP	--
8823	SIS	Globe/2	I	Air	Electrical Train N/A
8824	SIS	Globe/2	I	Air	Electrical Train N/A
8825	SIS	Globe/2	I	Air	Electrical Train N/A

TABLE 6.3-11 (Cont'd)

VALVE LOCATION NUMBER	SYSTEM	TYPE/ANS SAFETY CLASS	SEISMIC DESIGN CLASSIFICATION	ACTUATED BY	SERVICES (2)
8819 A/B/C/D	SIS	Check/1	I ⁽¹⁾	Δ P	--
8818 A/B/C/D	SIS	Check/1	I	Δ P	--
8890 A/B	SIS	Globe/2	I	Air	Electrical Train N/A
8809 A/B	SIS	Gate/2	I	Motor	Electrical Train A/B
8840	SIS	Gate/2	I	Motor	Electrical Train B
8804 B	SIS	Gate/2	I	Motor	Electrical Train B
8958 A/B	SIS	Check/2	I	Δ P	--
8812 A/B	SIS	Gate/2	I	Motor	Electrical Train A/B
8835	SIS	Gate/2	I	Motor	Electrical Train B
8821 A/B	SIS	Gate/2	I	Motor	Electrical Train A/B
8802 A/B	SIS	Gate/2	I	Motor	Electrical Train A/B
8881	SIS	Globe/2	I	Air	Electrical Train N/A
8888	SIS	Globe/2	I	Air	Electrical Train B
8922 A/B	SIS	Check/2	I	Δ P	--
8814	SIS	Globe/2	I	Motor	Electrical Train A
8920	SIS	Globe/2	I	Motor	Electrical Train A
8813	SIS	Globe/2	I	Motor	Electrical Train B
8923 A/B (Byron)	SIS	Gate/2	I	Motor	Electrical Train A/B
8926	SIS	Check/2	I	Δ P	--
8806	SIS	Gate/2	I	Motor	Electrical Train A
8811 A/B	SIS	Gate/2	I	Motor	Electrical Train A/B
8105	CVCS	Gate/2	I	Motor	Electrical Train B
8106	CVCS	Gate/2	I	Motor	Electrical Train A
8114	CVCS	Globe/2	I	Solenoid	Electrical Train A
8116	CVCS	Globe/2	I	Solenoid	Electrical Train B
8804 A	CVCS	Gate/2	I	Motor	Electrical Train A

B/B-UFSAR

TABLE 6.3-11 (Cont'd)

VALVE LOCATION NUMBER	SYSTEM	TYPE/ANS SAFETY CLASS	SEISMIC DESIGN CLASSIFICATION (1)	ACTUATED BY	SERVICES (2) (3)
8110	CVCS	Globe/2	I ⁽¹⁾	Motor	Electrical Train A
8111	CVCS	Globe/2	I	Motor	Electrical Train B
8440	CVCS	Check/2	I	ΔP	--
8481 A/B	CVCS	Check/2	I	ΔP	--
8546	CVCS	Check/2	I	ΔP	--
LCV-112 B/C	CVCS	Gate/2	I	Motor	Electrical Train A/B
LCV-112 D/E	CVCS	Gate/2	I	Motor	Electrical Train A/B
8716 A/B	RHRS	Gate/2	I	Motor	Electrical Train A/B
FCV-610	RHRS	Globe/2	I	Motor	Electrical Train A
FCV-611	RHRS	Globe/2	I	Motor	Electrical Train B
8730 A/B	RHRS	Check/2	I	ΔP	--

TABLE 6.3-11 (Cont'd)

PUMP	SYSTEM	ANS SAFETY CLASS	SEISMIC DESIGN CLASSIFICATION	SERVICES (3)
Centrifugal Charging No. 1 and 2	CVCS	2	I	Service Water, Bearing oil, Gear oil, electrical train A/B
Safety Injection No. 1 and 2	SIS	2	I	Service Water, Bearing oil, electrical train A/B
Residual Heat Removal No. 1 and 2	RHRS	2	I	C.C.W., electrical train A/B

Notes:

- (1) I, denotes Seismic Category I per paragraph (B) of Regulatory Guide 1.29.
- (2) Services other than "Air"; components requiring "Air" are designated as such in column Actuated By.
- (3) Does not include environment control services, i.e., HVAC.

Table 6.3-12 has been deleted intentionally.

This page has been deleted intentionally.

Table 6.3-13 has been deleted intentionally.

This page has been deleted intentionally.

TABLE 6.3-14

ECCS AIR OPERATED VALVES

VALVE LOCATION NUMBER	CORRECT POSITION FOLLOWING SAFEGUARDS ACTUATION	FAILURE POSITION	AUTOMATIC POSITIONING SIGNAL	POSITION INDICATION	
				RED/GREEN	MONITOR LIGHTS
SI8843	C	F.C.	--	Yes	--
SI8882	C	F.C.	--	Yes	--
SI8964	C	F.C.	T	Yes	Yes
SI8871	C	F.C.	T	Yes	Yes
SI8888	C	F.C.	T	Yes	Yes
SI8879 A/B/C/D	C	F.C.	--	Yes	--
SI8877 A/B/C/D	C	F.C.	--	Yes	--
SI8875 A/B/C/D	C	F.C.	--	Yes	--
SI8878 A/B/C/D	C	F.C.	--	Yes	--
SI8880	C	F.C.	T	Yes	Yes
SI8889 A/B/C/D	C	F.C.	--	Yes	--
SI8823	C	F.C.	--	Yes	--
SI8824	C	F.C.	--	Yes	--
SI8825	C	F.C.	--	Yes	--
SI8881	C	F.C.	--	Yes	Yes
SI8890 A/B	C	F.C.	--	Yes	--
FCV-618	C	F.C.	--	No*	--
FCV-619	C	F.C.	--	No*	--
HCV-606	O	F.O.	--	No*	Yes**
HCV-607	O	F.O.	--	No*	Yes**
HCV-943	C	F.C.	--	No*	--

F.C. - Fails Closed
F.O. - Fails Open
C - Closed
O - Open

* Position indication by percent valve opening.

**Provided with incorrect-closed position alarm on the Main Control Board.

Table 6.3-15 have been deleted intentionally.

This page have been deleted intentionally.

B/B-UFSAR

TABLE 6.3-16

ECCS VENT VALVES LOCATED INSIDE CONTAINMENT

LOCATION	<u>BRAIDWOOD</u> UNIT 1	<u>BRAIDWOOD</u> UNIT 2	<u>BYRON</u> UNIT 1	<u>BYRON</u> UNIT 2
RHR Cold Leg	1SI092	2SI092	1SI092	2SI139
	1SI093	2SI093	1SI093	
	1SI094	2SI094	1SI094	
	1SI096	2SI096	1SI140A	
	1SI097	2SI097	1SI140B	
SI Cold Leg	1SI083	2SI098A	1SI083	2SI128
	1SI098A	2SI098B	1SI128	2SI129
	1SI098B	2SI098C	1SI130	2SI130
	1SI098C	2SI098D	1SI131	2SI131
	1SI098D		1SI133	2SI132
				2SI133
			2SI134	
			2SI135	
			2SI136	
RHR Hot Leg	1SI089		1SI089	
SI Hot Leg	1SI085		1SI085	
SI Pumps Cold Leg Injection Header High Point Vent	1SI082		1SI082	

This page has been deleted intentionally.

TABLE 6.3-17

PERMANENT DESIGN ECCS AND CS SYSTEM VOID LOCATIONS

LOCATION	DESCRIPTION
Downstream of Valves 1/2SI8811A/B	Pump suction piping void within the bellows, valve canister, and valve body due to sloped piping.
Downstream of Valves 1/2CS009A	Pump suction piping void in the top of the pipe, elbow, and valve body due to the reduced port size of the gate valve.

B/B-UFSAR

APPENDIX 6.3A
PROPER POSITIONING OF VALVES

Spurious Actuation or Mispositioning of Motor-Operated Valves

In compliance with Branch Technical Position ICSB 18 (PSB), "Application of the Single Failure Criterion to Manually-Controlled Electrically-Operated Valves," Subsection 6.3.1 identifies valves that have a control board power removal and restoration provision and Subsection 8.1.10 states that provisions are provided to disconnected power to the valves electrical systems.

Additionally, these valves have monitor panel position indication and alarms should they be mispositioned during normal operation. The monitor panel position indication is in addition to the normal red-green position indication, and is provided via stem-mounted limit switches, which are independent of the normal limitorque position switches.

During normal plant operation as well as SI initiation following safeguards actuation, the above provisions ensure that motor-operated hot leg recirculation isolation valves SI8802A and SI8802B are or will remain in the correct position, which is closed, and are not subject to inadvertent operator mispositioning.

Spurious actuation or mispositioning of valve SI8835 would not terminate all cold leg injection flow. Valve SI8835 is in the cold leg injection path from the discharge of the safety injection pumps to the RCS. Any spurious actuation or mispositioning of this valve would affect only the safety injection pump subsystem of the safety injection system. The centrifugal charging pumps, residual heat removal pumps, and the accumulators also provide cold leg injection flow to the RCS, depending upon the prevailing RCS pressure, as their ECCS safety injection system function.

The motor-operated valve SI8813, located in the minimum flow bypass line for SI pumps, is protected against spurious operation as discussed above.

Administrative procedures require control room power lockout during normal operation with valve SI8813 in the open position. With these design provisions, any concern of damage to both safety injection pumps due to inadvertent valve movement is eliminated. Further, following an accident, power can easily be restored to the valve operator and the valve repositioned as required during switchover from the injection to the recirculation mode (also see Subsection 8.1.10).

Proper Positioning of Manually Operated Valves

There is no single ECCS manual valve which, through mispositioning, could result in the defeat of redundant ECCS trains. Manual valves are utilized in the ECCS as (1) maintenance isolation valves and (2) throttling valves. In addition, manual valves are utilized as redundant ECCS isolation valves. When utilized for these functions manual isolation

B/B-UFSAR

valves are under administrative control which require them to be locked in the correct position (i.e., locked open, locked closed, or locked in place) to support ECCS operation.

The following manual valves are utilized as maintenance isolation valves and are located so that no single valve can isolate both trains of ECCS equipment:

SI8921 A/B	Safety injection pump discharge
CV8471 A/B	Charging pump suction
CV8485 A/B	Charging pump discharge
RH8724 A/B	Residual heat removal pump discharge

The following manual valves are utilized as throttling valves in the injection branch paths of high and intermediate head ECCS pumps. These valves are located inside containment and are common to redundant pump subsystems. If incorrectly positioned, these valves could affect ECCS flow rates to the reactor coolant system. Pump runout protection is provided by the throttle valves via a specialized trim package.

SI8810 A/B/C/D	Charging pump to cold legs
SI8816 A/B/C/D	Safety injection pump to hot legs
SI8822 A/B/C/D	Safety injection pump to cold legs

The following manual valves are utilized as isolation valves in the ECCS cold leg injection path. These valves are located in the auxiliary building and are closed, if needed, when ECCS cold leg injection isolation valves SI8801A/B fail to close. These valves are installed in a parallel path in series with SI8801A/B valves so that no single valve can isolate both trains of ECCS equipment:

SI101A	SI8801A Upstream isolation valve
SI101B	SI8801B Upstream isolation valve

In addition to the above itemized valves, there are other ECCS manual valves which, through mispositioning, can degrade the performance of the ECCS in mitigating an accident. These valves, listed below, are under administrative control commensurate with their function in the ECCS. Additionally, all of these valves, with the exception of SX254 (Braidwood only) and CV8479A and B, have computer point inputs providing position indication that could be used to monitor availability of ECCS.

B/B-UFSAR

CV8479A & B	Centrifugal charging pump recirculation
SI8963	Return to RWST from accumulator fill line
CS002A & B	Containment spray pump suction
CS004A & B	Containment spray pump discharge
CS035A & B	Containment spray eductor motive flow supply
CS021A & B	Containment spray eductor NaOH supply
CS018A & B	Containment spray eductor NaOH supply
CS040A & B	Containment spray eductor NaOH supply
CS017A & B	Containment spray eductor NaOH supply

B/B-UFSAR

SI001A & B	Containment spray pump recirculation (Test) to RWST
AF002A & B	Auxiliary feedwater pump suction
AF009A & B	Auxiliary feedwater pump recirculation
CD091	Condensate storage tank isolation (AF suction)
CD022	Condensate storage tank isolation (makeup and overflow)
CD149	Auxiliary feedwater suction isolation
SX012A & B	Essential service water pump discharge to various heat exchangers
SX013A & B	Essential service water pump discharge to various heat exchangers
SX015A & B	Essential service water return from various heat exchangers
SX2102 (Braidwood Units 1 and 2)	Essential service water discharge from auxiliary feedwater pump lube oil cooler
SX052A & B	Essential service water supply to DG heat exchangers
SX057A & B	Essential service water discharge from heat exchangers
SX104A & B	Cross-tie valves to essential service water cooling of DG heat exchangers
SX105A & B	Cross-tie valves in essential service water cooling of DG heat exchangers
SX018A, B, C, & D	Essential service water supply to primary containment coolers
SX021A, B, C, & D	Essential service water discharge from primary containment coolers
SX022A, B C, & D	Essential service water supply to primary containment coolers

B/B-UFSAR

SX025A, B, C, & D	Essential service water discharge from primary containment coolers
SX254 (Braidwood only)	Essential service water discharge from primary containment coolers - A train only

Multiple valves in the component cooling system which provide cooling water to ESF equipment are also provided with position indication in the main control room.

RCS and ECCS piping has been reviewed to identify any lengths of piping which are isolated by normally closed valves and which do not have pressure relief protection in the piping section between the valves. The following categories of piping lengths were identified.

- a. Piping vents, drains, test connections, etc., typically have two closed valves or one closed valve and a blind flange.
- b. RCS loop fill and loop drain connections have two closed valves.
- c. ECCS check valve test lines have sections that are isolated by two closed valves.

In all cases, the identified piping sections have design pressure/temperature conditions compatible with the process piping to which they connect. Thus, valve leakage will not function to overpressurize the identified piping sections and pressure relief provisions to accommodate valve leakage are not required. Further, the identified piping segments are intended for normal operation functions and are not required to be operational either to cool down the plant or to mitigate any accidents requiring ECCS operation as discussed in Subsection 6.3.3.

Each of the two RHR loop suction valves which connect to the RCS hot legs and which are used for normal plant cooldown contain a section of piping inside containment which is isolated by two normally closed suction isolation valves (RH8701A/B and RH8702A/B). Although this section of piping is not considered to be either RCS or ECCS piping, it is required for plant cooldown. The possibility that heating could cause overpressurizations of this isolated section and the need for relief protection between the two series valves in each suction line has been evaluated (see Subsection 5.4.7.2.3).

6.4 HABITABILITY SYSTEMS

The Control Room Habitability Systems (CRHS) are plant systems that help ensure control room envelope (CRE) habitability. CRE habitability must be maintained during normal operations as well as during radiological, hazardous chemical, or smoke event emergencies. The CRHS includes the control room emergency ventilation/filtration system and the control room heating, ventilating and air-conditioning (HVAC) systems. The CRE boundary is considered an integral part of the CRHS, since it is critical to maintaining CRE habitability. The CRE is the area within the confines of the CRE boundary that contains the spaces that control room occupants inhabit to control the unit during normal and accident conditions. This area encompasses the control room and other non-critical areas to which frequent personnel access, or continuous occupancy is not necessary in the event of an accident. The CRE is protected during normal operation, natural events, and accident conditions. The CRE boundary is the combination of walls, floor, roof, ducting, doors, penetrations and equipment that physically form the CRE. The CRE boundary must be maintained to ensure that the inleakage of unfiltered air into the CRE will not exceed the inleakage assumed in the licensing basis analysis of design basis accident consequences to CRE occupants.

Adequate food, water storage, sanitary facilities, and medical supplies are provided to meet the requirements of operating personnel during and after an incident. In addition, the environments in all spaces served by the control room HVAC system (control room envelope) are controlled within specified limits which are conducive to prolonged service life of Safety Class 1 components during all station conditions.

6.4.1 Design Basis

The design bases of the habitability systems upon which the functional design is established are summarized as follows:

- a. Redundant strings of HVAC equipment are provided to maintain habitable environmental conditions in the control room envelope.
- b. The habitability systems are designed to support a maximum of seven people during normal and 30 days of abnormal station operating conditions. During an emergency, action will be taken as needed to deliver food to the control room operating personnel. An unlimited water supply and onsite first aid is available.
- c. Sanitary facilities are provided for control room operating personnel.

- d. The radiological effects on the control room envelope resulting from any incident described in Chapter 15.0 are considered in the design of the habitability system.
- e. The design includes provisions to preclude the effects of toxic gases (carbon dioxide and smoke) from inside or outside the plant.
- f. Seven SCBA units are available inside the control room envelope with dedicated air bottles. Two additional units are provided to comply with the single failure criteria described in Regulatory Guide 1.95. Additional reserve air supplies are maintained onsite to provide a total of six hours of breathing air for each of the seven emergency staff personnel.
- g. The habitability systems are designed to operate effectively during and after a DBA such as a LOCA with the simultaneous loss of offsite power, safe shutdown earthquake, or failure of any one of the control room HVAC system equipment string components.
- h. Radiation monitors and ionization detectors continuously monitor the control room HVAC system outside makeup air intakes. Also, ionization, humidity, and HELB pressure detectors continuously monitor the control room HVAC system turbine building makeup air intakes. Detection of high humidity is alarmed in the control room. Detection of HELB pressure affects the damper alignment for the air supply to the emergency makeup filter units during emergency operation as described in Subsection 6.4.3. Area radiation monitors are provided in the control room. Detection of high radiation or products of combustion is alarmed in the control room and related protection functions are simultaneously initiated. Pressure differential indicators are provided in the control room which monitor the pressure differential between strategic areas within the control room envelope and surrounding areas. Low pressure differential is alarmed in the control room.

Outdoor air and individual room temperature indicators in the control room are provided for the control room envelope.

- i. The CRE Boundary is maintained to ensure that unfiltered inleakage into the CRE will not exceed the inleakage assumed in the licensing basis analysis of Design Basis Accident consequences to CRE occupants. The assumed amount of unfiltered inleakage is provided in Table 6.4-1a.

6.4.2 System Design

6.4.2.1.1 Definition of Control Room

The control room consists of the main control room (Units 1 and 2), Shift Manager's office/records room, main control room toilet, and storage room.

6.4.2.1.2 Definition of Control Room Envelope

The control room envelope consists of control room, auxiliary electric equipment rooms, upper cable spreading rooms, control room HVAC equipment rooms, security control center, locker rooms, toilet, janitor's closet, electronic shop, and corridors.

6.4.2.2 Ventilation System Design

Detailed control room HVAC system description is presented in Subsection 9.4.1. The control room emergency makeup unit is described in Subsection 6.5.1.

All the system equipment components are designed to perform their function during and after the safe shutdown earthquake except for the electric space heating, humidification equipment, the security computer A/C unit, and toilet and locker room recirculation filter units, which are supported to remain intact, but may not function.

All system components are protected from internally and externally generated missiles. A layout of the control room envelope, showing doors, corridors, stairways, and boundary walls/floors/ceilings given in Drawing M-1033-13. Shield walls are shown on Figure 6.4-2.

The description of controls, instruments, and ionization and radiation monitors for the control room HVAC system is included

in Subsections 7.1.2.1 and 7.3.1.1. The locations of makeup air intakes and potential sources of radioactive and toxic gas releases are indicated in Drawings M-1323-1 and M-1323-8 and Figures 6.4-3 and 6.4-4.

6.4.2.3 Leaktightness

The entire control room envelope is designed as a low-leakage construction. All cable pans and duct penetrations are sealed. Approximately 6,000 cfm of outside air is introduced in the control room envelope except during the 100% outdoor air purge mode and (Braidwood only) chlorine isolation mode. This quantity of air is sufficient to maintain the control room envelope at a positive pressure with respect to areas adjacent to the CRE to minimize unfiltered inleakage. The positive pressure inside the control room envelope minimizes infiltration of potentially contaminated air from adjacent areas.

During emergency operation (radiation accident) of the control room ventilation system, the normally open minimum outside air makeup dampers are closed. Infiltration through damper and personnel ingress/egress is the only expected source of unfiltered air into the system. Analyzed unfiltered inleakage values are provided in Table 6.4-1a.

Technical Specification 5.5.18, "Control Room Envelope Habitability," requires determining the amount of unfiltered air inleakage in accordance with the testing methods and frequencies specified in Sections C.1 and C.2 of Regulatory Guide 1.197, "Demonstrating Control Room Envelope Integrity at Nuclear Power Reactors," Revision 0, May 2003.

6.4.2.4 Interaction With Other Zones and Pressure-Containing Equipment

The control room HVAC system serves only rooms in the control room envelope. Areas surrounding the control room envelope are served by various systems.

The control room offices HVAC system (a separate system, not a part of the control room envelope) is shut down by a high radiation signal detected in the control room HVAC system outside air intakes. The auxiliary building areas adjacent to the control room envelope are at negative pressure with respect to ambient and control room pressures at all times. The naturally vented turbine building pressure is a function of elevation and will vary seasonally depending on outside air temperatures. The building pressure at the main floor is approximately atmospheric at all times.

BYRON-UFSAR

All penetrations between the cable spreading rooms and the control room are sealed airtight. Any release of carbon dioxide within the cable spreading room would not enter the control room. Actuation of any of the carbon dioxide zone systems isolates that zone from airflow by simultaneously closing the airflow dampers surrounding the affected zone.

Normal access paths between plant areas and the control room envelope are double-door (two doors in series) vestibules to minimize system interaction. Single doors are not normally used and are under administrative control of the operator.

There are no high-energy lines in the proximity or within the control room envelope. Small fire extinguishers are provided in areas within the control room envelope.

6.4 HABITABILITY SYSTEMS

The Control Room Habitability Systems (CRHS) are plant systems that help ensure control room envelope (CRE) habitability. CRE habitability must be maintained during normal operations as well as during radiological, hazardous chemical, or smoke event emergencies. The CRHS includes the control room emergency ventilation/filtration system and the control room heating, ventilating and air-conditioning (HVAC) systems. The CRE boundary is considered an integral part of the CRHS, since it is critical to maintaining CRE habitability. The CRE is the area within the confines of the CRE boundary that contains the spaces that control room occupants inhabit to control the unit during normal and accident conditions. This area encompasses the control room and other non-critical areas to which frequent personnel access, or continuous occupancy is not necessary in the event of an accident. The CRE is protected during normal operation, natural events, and accident conditions. The CRE boundary is the combination of walls, floor, roof, ducting, doors, penetrations and equipment that physically form the CRE. The CRE boundary must be maintained to ensure that the inleakage of unfiltered air into the CRE will not exceed the inleakage assumed in the licensing basis analysis of design basis accident consequences to CRE occupants.

Adequate food, water storage, sanitary facilities, and medical supplies are provided to meet the requirements of operating personnel during and after an incident. In addition, the environments in all spaces served by the control room HVAC system (control room envelope) are controlled within specified limits which are conducive to prolonged service life of Safety Class 1 components during all station conditions.

6.4.1 Design Basis

The design bases of the habitability systems upon which the functional design is established are summarized as follows:

- a. Redundant strings of HVAC equipment are provided to maintain habitable environmental conditions in the control room envelope.
- b. The habitability systems are designed to support a maximum of seven people during normal and 30 days of abnormal station operating conditions. During an emergency, action will be taken as needed to deliver food to the control room operating personnel. An unlimited water supply and onsite first aid is available.
- c. Kitchen and sanitary facilities are provided for control room operating personnel.

BRAIDWOOD-UFSAR

- d. The radiological effects on the control room envelope resulting from any incident described in Chapter 15.0 are considered in the design of the habitability system.
- e. The design includes provisions to preclude the effects of toxic gases (carbon dioxide and smoke) from inside or outside the plant.
- f. Seven SCBA units are available inside the control room envelope with dedicated air bottles. Two additional units are provided to comply with single failure criteria from Regulatory Guide 1.95. Additional bottled air supplies are maintained onsite to provide a total of 6 hours of breathing air for each of the seven emergency staff personnel. Proceduralized methods are available to refill SCBAs if required for long term use.
- g. The habitability systems are designed to operate effectively during and after a DBA such as a LOCA

with the simultaneous loss of offsite power, safe shutdown earthquake, or failure of any one of the control room HVAC system equipment string components.

- h. Radiation monitors and ionization detectors continuously monitor the control room HVAC System outside makeup air intakes. Also, ionization, humidity, and HELB pressure detectors continuously monitor the control room HVAC system turbine building makeup air intakes. Detection of high humidity is alarmed in the control room. Detection of HELB pressure affects the damper alignment for the air supply to the emergency makeup filter units during emergency operation as described in Subsection 6.4.3. Area radiation monitors are provided in the control room. Detection of high radiation or products of combustion is alarmed in the control room and related protection functions are simultaneously initiated. Pressure differential indicators are provided in the control room which monitor the pressure differential between strategic areas within the control room envelope and surrounding areas. Low pressure differential is alarmed in the control room.

Outdoor air and individual room temperature indicators in the control room are provided for the control room envelope.

- i. The CRE Boundary is maintained to ensure that unfiltered inleakage into the CRE will not exceed the inleakage assumed in the licensing basis analysis of Design Basis Accident consequences to CRE occupants. The assumed amount of unfiltered inleakage is provided in Table 6.4-1a.

6.4.2 System Design

6.4.2.1.1 Definition of Control Room

The control room consists of the main control room (Units 1 and 2), Shift Manager's office/records room, main control room toilet, and storage room.

6.4.2.1.2 Definition of Control Room Envelope

The control room envelope consists of control room, auxiliary electric equipment rooms, upper cable spreading rooms, control room HVAC equipment rooms, security control center, locker room, toilet, kitchen, janitor's closet, electronic shop, and corridors.

6.4.2.2 Ventilation System Design

Detailed control room HVAC system description is presented in Subsection 9.4.1. The control room emergency makeup unit is described in Subsection 6.5.1.

All the system equipment components are designed to perform their function during and after the safe shutdown earthquake except for the electric space heating, humidification equipment, the security computer A/C unit, and kitchen, toilet, locker room exhaust fans and filters, and storage room toilet recirculation filter unit which are supported to remain intact, but may not function.

All system components are protected from internally and externally generated missiles. A layout of the control room envelope, showing doors, corridors, stairways, and boundary walls/floors/ceilings is given in Drawing M-1033-13. Shield walls are shown on Figure 6.4-2.

The description of controls, instruments, and ionization and radiation monitors for the control room HVAC system is included in Subsections 7.1.2.1 and 7.3.1.1. The locations of makeup air intakes and potential sources of radioactive and toxic gas releases are indicated in Drawings M-1323-1 and M-1323-8 and Figures 6.4-3, and 6.4-4.

6.4.2.3 Leaktightness

The entire control room envelope is designed as a low-leakage construction. All cable pans and duct penetrations are sealed. Approximately 6,000 cfm of outside air is introduced in the control room envelope except during the 100% outdoor air purge mode and (Braidwood only) chlorine isolation mode. This quantity of air is sufficient to maintain the control room envelope at a positive pressure with respect to areas adjacent to the CRE to minimize unfiltered inleakage. The positive pressure inside the control room envelope minimizes infiltration of potentially contaminated air from adjacent areas.

During emergency operation (radiation accident) of the control room ventilation system, the normally open minimum outside air makeup dampers are closed. Infiltration through damper and personnel ingress/egress is the only expected source of unfiltered air into the system. Analyzed unfiltered inleakage valves are provided in Table 6.4-1.

Technical Specification 5.5.18, "Control Room Envelope Habitability," requires determining the amount of unfiltered air inleakage in accordance with the testing methods and frequencies specified in Sections C.1 and C.2 of Regulatory Guide 1.197, "Demonstrating Control Room Envelope Integrity at Nuclear Power Reactors," Revision 0, May 2003.

6.4.2.4 Interaction With Other Zones and Pressure-Containing Equipment

The control room HVAC system serves only rooms in the control room envelope. Areas surrounding the control room envelope are served by various systems.

BRAIDWOOD-UFSAR

The control room offices HVAC system (a separate system, not a part of the control room envelope) and the laboratory HVAC system and the radwaste HVAC system are shut down by a high radiation signal detected in the control room HVAC system outside makeup air intakes. The auxiliary building areas adjacent to the control room envelope are at negative pressure with respect to ambient and control room pressures at all times. The naturally vented turbine building pressure is a function of elevation and will vary seasonally depending on outside air temperatures. The building pressure at the main floor is approximately atmospheric at all times.

All penetrations between the cable spreading rooms and the control room are sealed airtight. Any release of carbon dioxide within the cable spreading room would not enter the control room. Actuation of any of the carbon dioxide zone systems isolates that zone from airflow by simultaneously closing the airflow dampers surrounding the affected zone.

Normal access paths between plant areas and the control room envelope are double-door (two doors in series) vestibules to minimize system interaction. Single doors are not normally used and are under administrative control of the operator.

There are no high-energy lines in the proximity or within the control room envelope. Small fire extinguishers are provided in areas within the control room envelope.

The carbon dioxide fire protection system design is discussed in Subsection 2.3.3 and Appendix A5.4 of the Fire Protection Report.

6.4.2.5 Shielding Design

The design-basis accident for the control room area shielding is the loss-of-coolant accident (LOCA). The shielding is designed so that the doses to the control room personnel over the course of the accident are well below the limit specified in General Design Criteria 19 of 10 CFR 50, Appendix A.

The design of the control room envelope shielding is based on the sources given in Table 6.4-1. The distribution of the LOCA sources outside the control room are shown in Figures 6.4-3 and 6.4-4. All of the noble gases and iodines are presumed to remain airborne and eventually escape into the plume. Radioactive decay in the plume is ignored.

Shielding thicknesses for the control room are shown in Figure 6.4-2 and enumerated in Table 6.4-1. The sources for the LOCA shielding model are shown in Figures 6.4-3 and 6.4-4.

6.4.3 System Operational Procedures

The control room is a common facility which serves both Units 1 and 2. The facility is served by two completely redundant HVAC equipment trains. The systems are shown in simplified schematic in Figures 6.4-5, 6.4-6, 6.4-7; and 6.4-8 (Byron only). Note that only one of the redundant trains is detailed in the sketches; the other train contains equivalent equipment. The control room envelope is supplied with filtered, cooled and reheated (as necessary) air to maintain a suitable environment.

Under normal conditions the system operates as shown in Figure 6.4-5. The supply air consists of air that is recirculated from the control room envelope and outside air that is induced into the system to provide for control room envelope pressurization and to makeup for air that is exhausted. This mixture of recirculated and outside air is mixed and then passed through high-efficiency filters and then bypasses the charcoal adsorbers prior to being discharged into the control room.

Upon detection of high radiation in the minimum outside air intake, or upon a safety injection signal, the normally open outside air dampers close. The normally closed dampers of the turbine building emergency air intake are opened and the emergency makeup air filter unit is started. In addition, air that is normally bypassing the recirculation charcoal adsorber is routed through this charcoal adsorber. All of these actuations

are automatic and the new system line-up is shown diagrammatically in Figure 6.4-6.

In addition, a radiation monitor located on each of the emergency makeup air filter trains monitors the radiological quality of the air delivered to the control room envelope.

For an event involving a HELB in the turbine building that results in a safety injection signal, the normally open outside air dampers close. The normally closed dampers of the turbine building emergency air intake remain closed, and the emergency makeup air filter unit is started. The outside air bypass line intake damper is opened, and air that is normally bypassing the recirculation charcoal adsorber is routed through this charcoal adsorber. This is shown diagrammatically in Figure 6.4-7.

The operator also has manual capability for placing the system in the desired mode for responding to a HELB in the turbine building. Should high moisture due to a HELB in the turbine building occur, a humidity sensor located in the turbine building emergency makeup air intake will annunciate this condition in the main control room. This will alert the operator of this condition. The operator may then draw the makeup air from the minimum outside air intake by opening the normally closed bypass damper and closing the turbine building emergency makeup air intake damper. This is shown diagrammatically in Figure 6.4-7. In this minimum outside air intake configuration, the control room HVAC system will not automatically realign to the turbine building makeup air intake on a high radiation or ESF-SI actuation.

To remove any toxic gases, odors, and smoke from the control room environs, a charcoal adsorber is provided with each control room HVAC equipment string. These adsorbers, located downstream of high-efficiency filters, are normally bypassed. At Braidwood, if the station is notified of a toxic gas release in the near vicinity, the control room HVAC system is manually isolated via a control switch on the local panel. Actuation of the control switch places the system in 100% recirculation mode and routes the air through the charcoal adsorbers.

On detection of ionization products in the return air duct or mixed air plenum, the mixed air (return air and makeup air) is automatically routed through the charcoal adsorber and annunciated on the main control board. The operator may continue to route the system supply air through the charcoal adsorber for smoke removal, or depending on the condition of the outside air, may manually bypass the charcoal adsorber and purge the entire system with outside air. On ionization detection in outdoor makeup air intake, annunciation in the control room alerts the operator to transfer operation to a redundant equipment string utilizing a remote intake.

With the exception of an event involving a HELB in the turbine building, in the event of high radiation detection in the makeup air intake of the control room HVAC system, the radiation monitoring system automatically shuts off normal outside makeup air supply to the system. The minimum outside air requirement is obtained from the turbine building makeup air intake and is routed through the emergency makeup air filter unit and fan (for removal of radioactive particulates and iodine) before being supplied to the system. The makeup air is then mixed with return air and is routed through the recirculation charcoal adsorber for the removal of radioactive iodine before being supplied to the vital areas of the control room envelope. For an event involving a HELB in the turbine building, the minimum outside air requirement is obtained from the outside air bypass line intake to the emergency makeup unit.

Two emergency makeup air filter units and fans are provided, each capable of handling minimum requirements of makeup air for the system. In the event of high radiation levels, each train is

sized to process 6,000 cfm of makeup air. The emergency makeup air filter units are described in detail in Subsection 6.5.1.

At Byron, to preclude injecting a HEPA filter challenging agent into the control room envelope during emergency makeup air unit filter testing, the makeup air filter unit may be operated with the system in purge mode. This configuration is illustrated in Figure 6.4-8. The filter challenging agent is injected into the makeup air filter housing, mixes with the air being purged from the control room envelope and is expelled to the outside air. The makeup air filter unit air inlet is aligned to the outside air intake to protect the control room envelope from a high radiation condition in the intake air. A high radiation condition in the outside air would result in a high radiation signal being generated that would realign the purge dampers such that all air entering the control room envelope would be treated by the makeup air filter unit. In this makeup outside air intake configuration, the control room HVAC system will not automatically realign to the turbine building makeup air intake on a high radiation or ESF-SI actuation.

6.4.4 Design Evaluation

The control room HVAC system is designed to maintain a habitable environment compatible with prolonged service life of safety-related components in the control room under all the station operating conditions. The system is only provided with redundant equipment strings to meet the single-failure criterion. The equipment strings are powered from redundant Unit 1 ESF buses and are operable during loss of offsite power. All the control room HVAC system equipment except heating and humidification equipment is designed for Seismic Category I loads.

6.4.4.1 Radiological Protection

Two radiation monitors are provided in each control room HVAC system makeup air intake to detect high radiation. These monitors cause annunciation in the control room upon detection of high radiation or monitor failure conditions. Area radiation monitors are provided in the control room. The respective emergency makeup air filter unit connected to the operating equipment string (designed to remove radioactive particulates and adsorb radioactive iodine from the minimum quantity of makeup air) is automatically started upon high radiation signals in makeup air. The radiation monitors are described in detail in Subsections 11.5.2 and 12.3.4.

The control room ventilation system along with the CRE and control room shielding are designed to limit the occupational dose below levels required by General Design Criterion 19 of 10 CFR 50 Appendix A.

The introduction of the minimum quantity of outside air to maintain the control room and other areas served by the control room HVAC system at a positive pressure with respect to

external areas adjacent to the CRE boundary, at all the station operating conditions (except at Braidwood, when the system is in recirculation mode) minimizes the possibility of infiltration of unfiltered air into the control room (see Subsection 6.4.2.3).

The physical location of makeup air intakes (see Drawings M-1323-1 and M-1323-8) provides the option of drawing makeup air for the control room HVAC system from the less contaminated intake during and after an event involving the release of airborne activity. It is possible one of the makeup intakes may not have any contaminants, while the other intake may have contaminants. For an event involving a HELB in the turbine building, makeup air is drawn from outside to prevent excessive moisture and heat from entering the control room.

An assessment of the radiological dose to control room occupants has been made for the loss-of-coolant accident (LOCA) postulated in Subsection 15.6.5, as well as other design bases accidents.

Control room AST dose results are given in Tables 15.0-11 and 15.0-12.

For the DBA LOCA case, core inventory radionuclide release fractions are per Regulatory Guide 1.183 Table 2, and are available for release to the environment during the phased release period. Leakage from ESF equipment handling post-LOCA fluids is taken from Table 15.6-13. Credit for reduction of the amount of iodine available for release by engineered safety features (ESF) containment sprays is taken. Similarly credit is taken for the ESF control room makeup air filters (Subsection 6.5.1), the recirculation charcoal adsorbers, and ESF auxiliary building filters (Subsection 6.5.1).

The total dose as depicted in Figure 6.4-4 is comprised of four components, three of which are dependent on site meteorology. The effective atmospheric dispersion values, χ/Q , used were calculated using the "Atmospheric Relative CONcentrations in Building Wakes" (ARCON96) methodology (Reference 1), as shown in Section 2.3.6. ARCON96 calculates the highest 5th percentile χ/Q values for the entire accident period (i.e., 0-2 hours, 2-8 hours, 8-24 hours, 1-4 days, and 4-30 days) using the on-site meteorological data. The values of χ/Q used in this analysis are given in Table 6.4-1a.

Control room occupancy factors were taken from Table 1 of Reference 2.

When in accident mode, the control room HVAC system design has all incoming air passing through HEPA and charcoal filters. In addition, the makeup air mixes with the recirculation air flow and the mixture passes through the recirculation charcoal filter and medium efficiency filter. The filtration of intake and recirculation air flows limit the buildup of airborne iodine in the control room.

The resulting parametric factors and associated doses are given in Table 6.4-1. The doses are below General Design Criterion 19 to 10 CFR 50, Appendix A guidelines as interpreted by NUREG-0800, Section 6.4.

6.4.5 Testing and Inspection

The control room HVAC system and its components are thoroughly tested in a program consisting of the following:

- a. factory and component qualification tests,
- b. onsite preoperational testing, and
- c. onsite subsequent periodic testing.

Periodic inleakage testing of the CRE is performed in general conformance to Regulatory Guide 1.197 Revision 0 Sections C.1 and C.2.

Written test procedures establish minimum acceptable values for all tests. Test results are recorded as a matter of performance record, thus enabling early detection of faulty performance.

All equipment is factory inspected and tested in accordance with the applicable equipment specifications, codes, and quality assurance requirements. System ductwork and erection of equipment is inspected during various construction stages for quality assurance. Construction tests are performed on all mechanical components, and the system is balanced for the design airflows and system operating pressures. Controls, interlocks, and safety devices on each system are cold checked, adjusted, and tested to ensure the proper sequence of operation.

The equipment manufacturers' recommendations and station practices are considered in determining required maintenance.

6.4.6 Instrumentation Requirements

All the instruments and controls for the control room HVAC system are electric or electronic. Further details are provided in the following:

- a. Each redundant control room HVAC system has a local control panel, and each is independently controlled. Important operating functions are controlled and monitored from the main control room. Local control panels containing the local control switches are located inside equipment rooms that are under the administrative control of operators.
- b. Instrumentation is provided to monitor important variables associated with normal operation and to alarm abnormal conditions on the main control board.
- c. A radiation detection system is provided to monitor the radiation levels at the system outside air intakes. A high radiation signal is alarmed on the main control board.

BYRON-UFSAR

- d. The ionization detection is provided both in rooms and in the return air path from main control boards. Ionization detection is annunciated in the main control room.
- e. A pressure monitoring system has been provided to detect the presence of a HELB environment at the turbine building intake and initiate appropriate protective actions.
- f. The control room HVAC system is designed for automatic environmental control with manual starting of fans.
- g. A fire protection system water connection is provided to each charcoal adsorber bed.
- h. The various instruments of the control system are described in detail in Chapter 7.0.
- i. The emergency makeup air filter unit upstream HEPA filter high differential pressure is annunciated. The emergency makeup air filter unit high and low airflow rates are annunciated in the main control room. This airflow rate is indicated on the local control panel.
- j. The control room supply fan high and low differential pressures are annunciated in the main control room. Supply fan trip is also annunciated in the main control room. Supply fan differential pressure is indicated on the local control panel.

6.4.4.2 Chlorine Gas Protection

The control room HVAC system is provided with control switches on the local control panels which can manually isolate the system upon notification of an accidental release of chlorine gas from sources external to the station. Upon isolation of the system from outdoor makeup air, the control room HVAC system operates in 100% recirculation mode, thus routing the recirculated air through recirculation filters.

6.4.5 Testing and Inspection

The control room HVAC system and its components are thoroughly tested in a program consisting of the following:

- a. factory and component qualification tests,
- b. onsite preoperational testing, and
- c. onsite subsequent periodic testing.

Periodic inleakage testing of the CRE is performed in general conformance to Regulatory Guide 1.197 Revision 0 Sections C.1 and C.2.

Written test procedures establish minimum acceptable values for all tests. Test results are recorded as a matter of performance record, thus enabling early detection of faulty performance.

All equipment is factory inspected and tested in accordance with the applicable equipment specifications, codes, and quality assurance requirements. System ductwork and erection of equipment is inspected during various construction stages for quality assurance. Construction tests are performed on all mechanical components, and the system is balanced for the design airflows and system operating pressures. Controls, interlocks, and safety devices on each system are cold checked, adjusted, and tested to ensure the proper sequence of operation.

The equipment manufacturers' recommendations and station practices are considered in determining required maintenance.

6.4.6 Instrumentation Requirements

All the instruments and controls for the control room HVAC system are electric or electronic. Further details are provided in the following:

- a. Each redundant control room HVAC system has a local control panel, and each is independently controlled. Important operating functions are controlled and monitored from the main control room. Local control panels containing the local control switches are located inside equipment rooms that are under the administrative control of operators.

BRAIDWOOD-UFSAR

- b. Instrumentation is provided to monitor important variables associated with normal operation and to alarm abnormal conditions on the main control board.
- c. A radiation detection system is provided to monitor the radiation levels at the system outside air intakes. A high radiation signal is alarmed on the main control board.
- d. The ionization detection is provided both in rooms and in the return air path from main control boards. Ionization detection is annunciated in the main control room.
- e. A pressure monitoring system has been provided to detect the presence of a HELB environment at the turbine building intake and initiate appropriate protective actions.
- f. The control room HVAC system is designed for automatic environmental control with manual starting of fans.
- g. A fire protection system water connection is provided to each charcoal adsorber bed.
- h. The various instruments of the control system are described in detail in Chapter 7.0.
- i. The emergency makeup air filter unit upstream HEPA filter high differential pressure is annunciated. The emergency makeup air filter unit high and low airflow rates are annunciated in the main control room. This airflow rate is also indicated and the low airflow is annunciated on the local control panel.
- j. The control room supply fan high and low differential pressures are annunciated in the main control room. Supply fan trip is also annunciated in the main control room. Supply fan differential pressure is indicated on the local control panel.

6.4.7 References

1. Ramsdell, J. V. Jr. and C. A. Simonen, "Atmospheric Relative Concentrations in Building Wakes". Prepared by Pacific Northwest Laboratory for the U.S. Nuclear Regulatory Commission, PNL-10521, NUREG/CR-6331, Rev. 1, May 1997.
2. Murphy, K.G., and Campe, K.H., "Nuclear Power Plant Control Room Ventilation System Design for Meeting General Design Criterion 19, " Proceedings of the Thirteenth AEC Air Cleaning Conference, August 1974.
3. NEI 99-03, "Control Room Habitability Assessment Guidance," June 2001. |

BYRON-UFSAR

TABLE 6.4-1

EXPECTED DOSE TO CONTROL ROOM PERSONNEL AT BYRON STATION
FOLLOWING A LOSS-OF-COOLANT ACCIDENT (LOCA)

	CONCRETE SHIELD THICKNESS BETWEEN SOURCE AND CONTROL ROOM, INCHES	<u>ACCUMULATED 30 DAY DOSE, REM</u> TEDE
Direct Dose From Airborne Radio- activity in the Containment	Sidewall - 102 Ceiling - 68	0.023
Dose From Post-LOCA Plume Surrounding Control Room	24	0.015
Dose From Radioactivity Accumulated on Control Room Makeup Air Filters	8	0.013
Dose From Air Drawn into the Control Room		
From Containment Leakage	N/A	3.35
From ESF Equipment Leakage	N/A	1.54
10 CFR 50.67 limits		5

Note: Principal assumptions are listed in Table 6.4-1a.

BYRON-UFSAR

TABLE 6.4-1a

PRINCIPAL ASSUMPTIONS USED IN CONTROL ROOM
HABITABILITY CALCULATIONS

Loss-of-Coolant Accident Modeling	Subsection 15.6.5
Control room atmospheric dispersion factor (χ/Q) for Containment leakage	
0-0.5 hour	1.73E-3 sec/m ³
0.5-2 hour	1.01E-3 sec/m ³
2-8 hour	7.25E-4 sec/m ³
8-24 hour	3.07E-4 sec/m ³
24-96 hour	2.07E-4 sec/m ³
96-720 hour	1.46E-4 sec/m ³
Control room atmospheric dispersion factor (χ/Q) for ESF leakage	
0-0.5 hour	2.22E-3 sec/m ³
0.5-2 hour	2.46E-3 sec/m ³
2-8 hour	1.92E-3 sec/m ³
8-24 hour	8.14E-4 sec/m ³
24-96 hour	5.52E-4 sec/m ³
96-720 hour	4.40E-4 sec/m ³
Control room HVAC envelope volume	200,000 ft ³ (Note 1)
Control room volume used for finite cloud correction	70,275 ft ³
Control room air intake flow	6000 cfm \pm 10% (NOTE 2)
Control room air filtered recirculation flow	39,150 cfm
Control room air intake filter efficiency (all forms of iodine)	0.99 (particulate) 0.95 (elemental/organic)
Control room recirculation flow filter efficiency	
Elemental iodine	0.9
Organic iodine	0.9
ESF Equipment leak rate	UFSAR Table 15.6-13
Unfiltered inleakage into the control room	436 cfm

BYRON-UFSAR

TABLE 6.4-1a (continued)

PRINCIPAL ASSUMPTIONS USED IN CONTROL ROOM
HABITABILITY CALCULATIONS

Occupancy factor	
0-24 hour	1.0
24-96 hour	0.6
96-720 hour	0.4
Breathing rate	3.50E-4 m ³ /sec

NOTE 1: Based on a calculated volume of 230,830 ft³

NOTE 2: Based on various failure modes and assumptions, the value used in the RADTRAD model may differ from 6000 cfm +/- 10%. See analysis BYR04-051 for exact details.

BRAIDWOOD-UFSAR

TABLE 6.4-1

EXPECTED DOSE TO CONTROL ROOM PERSONNEL AT BRAIDWOOD STATION
FOLLOWING A LOSS-OF-COOLANT ACCIDENT (LOCA)

	CONCRETE SHIELD THICKNESS BETWEEN SOURCE AND CONTROL ROOM, INCHES	<u>ACCUMULATED 30 DAY DOSE, REM</u> TEDE
Direct Dose From Airborne Radio- activity in the Containment	Sidewall - 102 Ceiling - 68	0.023
Dose From Post-LOCA Plume Sur- rounding Control Room	24	0.015
Dose From Radioactivity Accumu- lated on Control Room Makeup Air Filters	8	0.013
Dose From Air Drawn into the Control Room		
From Containment Leakage	N/A	3.35
From ESF Equipment Leakage	N/A	1.54
<hr/>		
10 CFR 50.67 Limits		5

Note: Principal assumptions are listed in Table 6.4-1a.

TABLE 6.4-1a

PRINCIPAL ASSUMPTIONS USED IN CONTROL ROOM
HABITABILITY CALCULATIONS

Loss-of-Coolant Accident Modeling	Subsection 15.6.5
Control room atmospheric dispersion factor (χ/Q) for Containment Leakage	
0-0.5 hour	1.73E-3 sec/m ³
0.5-2 hour	1.01E-3 sec/m ³
2-8 hour	7.25E-4 sec/m ³
8-24 hour	3.07E-4 sec/m ³
24-96 hour	2.07E-4 sec/m ³
96-720 hour	1.46E-4 sec/m ³
Control room atmospheric dispersion factor (χ/Q) for ESF leakage	
0-0.5 hour	2.22E-3 sec/m ³
0.5-2 hour	2.46E-3 sec/m ³
2-8 hour	1.92E-3 sec/m ³
8-24 hour	8.14E-4 sec/m ³
24-96 hour	5.52E-4 sec/m ³
96-720 hour	4.40E-4 sec/m ³
Control room HVAC envelope volume	200,000 ft ³ (Note 1)
Control room volume used for finite cloud correction	70,275 ft ³
Control room air intake flow	6000 cfm \pm 10% (Note 2)
Control room air filtered recirculation flow	39,150 cfm
Control room air intake filter efficiency (all forms of iodine)	0.99 (particulate) 0.95 (elemental/organic)
Control room recirculation flow filter efficiency	
Elemental iodine	0.9
Organic iodine	0.9
ESF Equipment leak rate	UFSAR Table 15.6-13
Unfiltered inleakage into the control room	436 cfm

BRAIDWOOD-UFSAR

TABLE 6.4-1a (continued)

PRINCIPAL ASSUMPTIONS USED IN CONTROL ROOM
HABITABILITY CALCULATIONS

Occupancy factor	
0-24 hour	1.0
24-96 hour	0.6
96-720 hour	0.4
Breathing rate	3.50E-4 m ³ /sec

NOTE 1: Based on a calculated volume of 232,872 ft³

NOTE 2: Based on various failure modes and assumptions, the values used in the RADTRAD model may differ from 6000 cfm +/- 10%. See analysis BRW-04-0038-M Revision 6 for details.

6.5 FISSION PRODUCT REMOVAL AND CONTROL SYSTEMS

6.5.1 Engineered Safety Feature (ESF) Filter Systems

The following filtration systems, which are required to perform the safety-related functions subsequent to a design-basis accident (DBA), are provided:

- a. control room HVAC makeup air filter units: this system is utilized to clean the incoming air of gaseous iodine and particulates which are potentially present in incoming air following an accident.
- b. auxiliary building exhaust system: this system can be utilized to reduce gaseous iodine and particulate concentrations in gases leaking from primary containment and which are potentially present in nonaccessible cubicles (see Subsection 9.4.5) following the accident.
- c. fuel handling building exhaust system: this system is utilized to reduce gaseous iodine and particulate concentrations in the exhaust air from the fuel handling building which are potentially present following a fuel drop accident, involving recently irradiated fuel (i.e., fuel that has occupied part of a critical core within the previous 48 hours).

6.5.1.1 Design Bases

6.5.1.1.1 Control Room Makeup Air Filter Units

- a. The makeup air filter units are designed to start automatically and provide outside air to the control room HVAC system in response to any one of the following signals:
 1. high radiation signal from the radiation monitors provided to monitor the radiation levels at the control room HVAC outside air intakes;
 2. manual activation from the main control room; and
 3. ESF signal.
- b. The alternative source term model described in NUREG-1465 and Regulatory Guide 1.183 is used in conjunction with approved methods to calculate the quantity of activity released as a result of an accident and to determine inlet concentrations to the makeup air filter train.
- c. The capacity of the makeup air filter units is based on the air quantity required to maintain the control room served by the control room HVAC system at

0.125 in. of H₂O positive pressure with respect to adjacent areas.

- d. Two full-capacity emergency makeup air filter units and associated dampers, ducts, and controls are provided.
- e. Each makeup air filter unit utilizes air heaters, demister, and prefilters needed to assure the optimum air conditions entering the high-efficiency particulate air (HEPA) filters and charcoal adsorbers.
- f. The emergency makeup air filter unit exhibits a removal efficiency of no less than 95% on gaseous forms of radioiodine and no less than 99% on all particulate matter 0.3 micron and larger in size.
- g. The makeup air filter unit is designed to meet the single-failure criterion.
- h. The power supplies meet IEEE 308-1974 criteria and ensure uninterrupted operation in the event of loss of normal ac power. The controls meet IEEE 279-1971.
- i. The makeup air filter units are designed to Safety Category 1 requirements.
- j. The makeup air filter units are designed to permit periodic testing and inspection of principal system components as described in Subsection 6.5.1.4.
- k. The electrical components are qualified in accordance with IEEE 344-1971 and IEEE 323-1974.

6.5.1.1.2 Auxiliary Building Exhaust Systems

- a. The auxiliary building exhaust system is designed to run continuously during all normal plant operations and exhaust auxiliary building air after filtering through prefilter and HEPA filter banks. Provisions are also made to route the effluents from nonaccessible cubicles in the auxiliary building (see Subsection 9.4.5) through charcoal adsorbers and HEPA filters on the following signals:
 - 1. Automatically on a safety injection signal from Unit 1 or 2.
 - 2. Manually through a control switch in the main control room.

- b. On loss-of-coolant accident concurrent with loss of offsite power, the auxiliary building supply and exhaust fans powered by the unit having a LOCA coincident with a LOOP are tripped. Two out of six charcoal booster fans are started, performing the following functions:

- 1. Maintain negative pressure in the auxiliary building.
- 2. Route the exhaust air from nonaccessible cubicles through the charcoal adsorber and downstream HEPA filter before exhausting to the outdoor atmosphere.

The auxiliary building supply and exhaust fans associated with the unit experiencing the LOCA/LOOP can be restarted manually by the control switch located on the main control panel after approximately 2 hours (based on expected ESF bus loading).

- c. The radioactive gases leaking from the primary containment after a LOCA or during normal operation are treated in order to remove particulates and radioactive and nonradioactive forms of iodine to limit the offsite dose.
- d. The auxiliary building exhaust system exhibits a removal efficiency of no less than 90% on radioactive and nonradioactive forms of iodine and no less than 99% on all particulate matter 0.3 micron and larger in size. The particulate removal efficiency is predicated on the use of HEPA filters having a 99% particulate removal efficiency. The charcoal is tested in accordance with Technical Specification Section 5.5.11 "Ventilation Filter Testing Program," and TRM Appendix K. The charcoal is contained in leak-tight, all-welded construction adsorbers to preclude bypass of the charcoal and to ensure the highest removal efficiencies on methyl iodine.
- e. The exhaust air from the auxiliary building exhaust system is released at an elevation of 599 feet 2 inches. The discharge air velocity from each auxiliary building exhaust system vent stack is approximately 60 fps maximum.
- f. The auxiliary building exhaust system is designed with redundancy to meet the single-failure criteria.
- g. The power supplies meet IEEE 308-1974 criteria and ensure uninterrupted operation in the event of loss

BRAIDWOOD-UFSAR

- b. On loss-of-coolant accident the auxiliary building supply and exhaust fans powered by the unit having a LOCA are tripped. Two out of six charcoal booster fans are started, performing the following functions:
 - 1. Maintain negative pressure in the auxiliary building.
 - 2. Route the exhaust air from nonaccessible cubicles through the charcoal adsorber and downstream HEPA filter before exhausting to the outdoor atmosphere.
- c. The radioactive gases leaking from the primary containment after a LOCA or during normal operation are treated in order to remove particulates and radioactive and nonradioactive forms of iodine to limit the offsite dose.
- d. The auxiliary building exhaust system exhibits a removal efficiency of no less than 90% on radioactive and nonradioactive forms of iodine and no less than 99% on all particulate matter 0.3 micron and larger in size. The particulate removal efficiency is predicated on the use of HEPA filters having a 99% particulate removal efficiency. The charcoal is tested in accordance with Technical Specification Section 5.5.11 "Ventilation Filter Testing Program," and TRM Appendix K. The charcoal is contained in leak-tight, all-welded construction adsorbers to preclude bypass of the charcoal and to ensure the highest removal efficiencies on methyl iodine.
- e. The exhaust air from the auxiliary building exhaust system is released at an elevation of 599 feet 2 inches. The discharge air velocity from each auxiliary building exhaust system vent stack is approximately 60 fps maximum.
- f. The auxiliary building exhaust system is designed with redundancy to meet the single-failure criteria.
- g. The power supplies meet IEEE 308-1974 criteria and ensure uninterrupted operation in the event of loss

of normal ac power. The controls meet IEEE 279-1971.

- h. The auxiliary building exhaust system is designed to Safety Category I requirements.
- i. The auxiliary building exhaust system is designed to permit periodic testing and inspection of the principal system components as described in Subsection 6.5.1.4.

6.5.1.1.3 Fuel Handling Building Exhaust System

- a. The fuel handling building exhaust system, which is part of the auxiliary building HVAC system (see Subsection 9.4.5.1), is designed to run continuously during all normal plant operating conditions and while filtering the exhaust air through prefilter HEPA filter banks. Provisions are also made to route the effluent from the fuel handling building through charcoal adsorbers and downstream HEPA filters on the following signals:
 - 1. Automatically on high radiation signal from redundant safety-related area monitors from fuel handling building,
 - 2. Automatically on a safety injection (SI) signal from Units 1 or 2, and
 - 3. Manually through a control switch in the main control room.
- b. The radioactive gases rising from the fuel pool following a fuel drop accident are treated in order to remove particulates and radioactive and nonradioactive forms of iodine to limit the offsite dose to the guidelines of 10 CFR 50.67.
- c. The fuel handling building exhaust system exhibits a removal efficiency of no less than 90% on elemental iodine, 30% on organic iodide, and no less than a 99% on all particulate matter 0.3 micron and larger in size. The particulate removal efficiency is predicated on the use of HEPA filters having 99% particulate removal efficiency. The charcoal is tested to less than 10% methyl iodide penetration when tested at a temperature of 30° C and 95% relative humidity. The charcoal is contained in leak-tight, all-welded construction adsorbers to preclude bypass of the charcoal and to ensure the highest removal efficiencies on methyl iodine.

- d. The fuel handling building exhaust system is designed with redundancy to meet the single-failure criterion.
- e. The power supplies meet IEEE 308-1974 criteria and ensure uninterrupted operation in the event of loss of normal ac power. The controls meet IEEE 279-1971.
- f. The fuel handling building exhaust system is designed to Safety Category I and Seismic Category I requirements.
- g. The fuel handling building exhaust system is designed to permit periodic testing and inspection of the principal system components as described in Subsection 6.5.1.4.
- h. The fuel handling building exhaust system is designed to maintain the fuel handling building at a negative pressure of 1/4 inch water gauge with respect to atmosphere.

6.5.1.2 System Design

6.5.1.2.1 Emergency Makeup Air Filter Units

- a. The makeup air filter units work in conjunction with the control room HVAC system. Refer to Subsection 9.4.1 for further discussion.
- b. With the exception of an event involving a HELB in the turbine building, in the event of high radiation detection in the makeup air intake of the control room HVAC system, the radiation monitoring system automatically shuts off normal outside makeup air supply to the system. The minimum outside air requirement is obtained from the turbine building makeup air intake and is routed through the emergency makeup air filter unit and fan (for removal of radioactive particulates and iodine) before being supplied to the system. The makeup air is then mixed with return air and is routed through the recirculation charcoal adsorber for the removal of radioactive iodine before being supplied to the vital areas of the control room envelope. For an event involving a HELB in the turbine building, the minimum outside air requirement is obtained from the outside air bypass line intake and is routed through the emergency makeup air filter unit and charcoal adsorber.

B/B-UFSAR

- c. Two redundant makeup air filter trains and fans are provided, each capable of handling 6000 cfm.
- d. Each makeup air filter unit is comprised of the following components in sequence:
 - 1. A demister which removes any entrained water droplets and moisture to minimize water droplets and water loading of the prefilter. The demister meets qualification requirements similar to those in Mine Safety Appliance Research (MSAR) Report 71-45 and will be UL Class I.

2. A single-stage electric heater, sized to reduce the humidity of the airstream to at least 70% relative humidity for the worst inlet conditions. A heater capacity of 23.8 kW was calculated using 110% of the filter design flow rate and entering air conditions of 95°F and 100% relative humidity. A 27.2-kW heater is provided.
3. A prefilter, UL listed, all glass media, exhibiting no less than 80% efficiency based on ASHRAE 52.
4. A high-efficiency particulate air (HEPA) filter, water resistant, capable of removing 99% minimum of particulate matter which is 0.3 micron or larger in size. The filter is designed to be fire resistant. Six 1000 cfm elements are provided. All elements are fabricated in accordance with NRC Health and Safety Bulletin 306, dated March 31, 1971, covering Military Specification MIL-F-51068 latest revision in effect at time of purchase, MIL-F-51079 latest revision in effect at time of purchase, UL-586, and after January 1995, AG-1 latest revision in effect at time of purchase.
5. A charcoal adsorber capable of removing not less than 99% of radioactive forms of iodine is provided. The charcoal adsorber is an all-welded airtight type, filled with impregnated coconut shell charcoal. The charcoal adsorber beds hold charcoal with 30 lb/ft³ density, having an ignition temperature of 340°C. Total bed depth is 4 inches.

The bed dimensions are so designed that the air has at least 0.25 seconds of residence time through the charcoal. The charcoal shall be of the best grade available at the time of installation and meets the requirements of ANSI N509-1976. Charcoal received after September 23, 1988 shall meet the requirements of ANSI N509-1980.

Ten test canisters are provided for each charcoal adsorber. These canisters contain the same depth of the same charcoal as in the charcoal adsorber. The canisters are so mounted that a parallel flow path is created between

each canister and the charcoal adsorber. Thus, the charcoal in the canisters is subjected to the same contaminants as the charcoal in the bed. Periodically, one of the canisters is removed and laboratory tested to reverify the adsorbent efficiency.

One deluge valve connected to the station fire protection system is mounted adjacent to each

charcoal adsorber bank. For each charcoal adsorber, a two-stage temperature switch is provided. When the first-stage setpoint (200°F) is exceeded, it is alarmed on the main control panel and indicated on the local control panel. When the second-stage setpoint (310°F) is exceeded, it is annunciated on the local control panel. After the second-stage setpoint is reached, the deluge valve can be actuated manually. Actuation of the deluge valves is indicated in the main control room.

6. A high-efficiency particulate filter identical to the upstream HEPA filter is provided to trap charcoal fines which are entrained by the airstream.
7. A fan induces the air from the intake louvers and the makeup air filter train and discharges it to the suction side of the control room air-handling equipment train. The fan performance is based on the maximum density and worst pressure condition, when it is inducing -10°F air from the outdoors and the makeup air filter train, containing filters which operate at no less than twice their clean pressure drop.
8. Full-size access doors adjacent to each filter are provided in the equipment train housing. Access doors are provided with transparent portholes to allow inspection and maintenance of components without violating the train integrity. Spacing between filter sections is based on ease of maintenance considerations.
9. The housing is an all-welded construction, heavily reinforced, and built to low leakage requirements.
10. Interior lights with external light switches are provided between all train components to facilitate inspection, testing, and replacement of components.

6.5.1.2.2 Auxiliary Building Exhaust System

- a. The auxiliary building exhaust system works in conjunction with the auxiliary building ventilation system as described in Subsection 9.4.5.

- b. In the event of high radiation detection in the auxiliary building exhaust air duct, the auxiliary building charcoal booster fans are started manually. The charcoal filter bypass dampers are closed automatically and the effluents are routed through the charcoal adsorbers (for removal of radioactive particulates and iodine) before being exhausted to the outdoors.
- c. The auxiliary building exhaust system, common to both Units 1 and 2, consists of the following in sequence:
 1. The following filter plenums operate in parallel:
 - a) Nonaccessible area exhaust filter plenums A, B, and C treating exhaust air from nonaccessible areas of the auxiliary building and discharging into auxiliary building exhaust plenum.
 - b) Fuel handling building exhaust plenum, treating exhaust air from fuel handling building and discharging into auxiliary building exhaust plenum.
 - c) Accessible area exhausts filter plenums, A, B, C, and D, treating exhaust air from accessible areas of the Auxiliary Building and discharging into auxiliary building exhaust plenum.
 2. Auxiliary building exhaust plenum.
 3. Four 50% capacity exhaust air fans drawing suction from the auxiliary building exhaust plenum. Two of the fans discharge into ductwork which directs air to the Unit 1 vent stack, and the other two fans discharge into ductwork which directs air to the Unit 2 vent stack.
 4. Unit 1 and Unit 2 vent stacks.
- d. Nonaccessible area exhaust filter plenums

Each of the three nonaccessible area exhaust filter plenums, A, B, and C, are identical, and each has 50% of the capacity required to treat exhaust air from nonaccessible areas, i.e., each plenum has an installed filter capacity of 62,000 cfm (for Byron) and 63,000 cfm (for Braidwood).

The exhaust air is routed from the potentially nonaccessible areas listed in Table 6.5-5.

Each nonaccessible area exhaust filter plenum consists of the following components in sequence:

1. An isolation damper.
 2. Three 20,910 cfm capacity each, HEPA filter subplenums connected to operate in parallel, each consisting of the following components:
 - a) A high-efficiency prefilter.
 - b) A HEPA filter.
 3. A bypass damper is provided downstream of the HEPA filters which provides direct connection to the auxiliary building exhaust filter plenum, bypassing the charcoal adsorber.
 4. Three, 20,910 cfm capacity each, charcoal adsorber plenums connected to operate in parallel, and each consisting of the following components:
 - a) A charcoal adsorber with fire protection provisions.
 - b) A downstream HEPA filter.
 5. Two charcoal adsorber booster fans with a design flow rate of 62,730 cfm each. (Each booster fan has a flow measuring element and a flow control damper downstream.)
- e. Fuel handling building exhaust plenum
This is described in detail in Subsection 6.5.1.2.3.
- f. Accessible area exhaust filter plenums (Non-ESF)

Each of the four accessible area exhaust filter plenums A, B, C, and D, are identical, and each has 33% of the capacity required to treat exhaust air from nonaccessible area, i.e., each plenum is designed to handle a nominal 41,830 cfm. Each accessible area exhaust filter plenum consists of the following components in sequence:

1. An upstream isolation damper.
 2. Three, 13,943-cfm capacity each, HEPA filter subplenums each consisting of the following components:
 - a) A high-efficiency prefilter.
 - b) A HEPA filter.
 3. A downstream isolation damper and a backdraft damper before discharging into the auxiliary building exhaust plenum.
- g. The high-efficiency prefilters provided in the auxiliary building exhaust system are UL listed, all-glass media, exhibiting no less than 80-85% efficiency based on ASHRAE 52.
- h. The high-efficiency particulate air (HEPA) filter provided in the auxiliary building exhaust system is water resistant and capable of removing 99% minimum of particulate matter which is 0.3 micron or larger in size. The filter is designed to be fire resistant. Each element provided is rated for 1000 cfm capacity. All elements are fabricated in accordance with NRC Health and Safety Bulletin 306, dated March 31, 1971, covering Military Specification MIL-F-51068 latest revision in effect at time of purchase, MIL-F-51079 latest revision in effect at time of purchase, UL-586, and after January 1995, AG-1 latest revision in effect at time of purchase.
- i. The charcoal adsorbers provided in the auxiliary building exhaust system are capable of removing not less than 90% of radioactive forms of iodine. The charcoal adsorbers are the tray type and are filled with impregnated coconut shell charcoal. The charcoal adsorber beds hold charcoal of 30 lb/ft³ density with an ignition temperature of 340°C. Total bed depth is 2 inches.

The bed dimensions are so designed that the air has at least 0.25 seconds of residence time through the charcoal. The charcoal shall be of the best grade available at the time of purchase and shall meet the requirements of ANSI N509-1976. Charcoal received after September 23, 1988 shall meet the requirements of ANSI N509-1980.

Ten test canisters are provided for each charcoal bank in each adsorber bank in each subplenum. These canisters contain the same depth of the same charcoal as in the charcoal adsorber. The canisters are so mounted that a parallel flow path

is created between each canister and the charcoal adsorber. The charcoal in the canister is thus subjected to the same contaminants as the charcoal in the bed. Periodically, one of the canisters is removed and laboratory tested to reverify the absorbent efficiency.

One deluge valve connected to the station fire protection system is mounted adjacent to each charcoal adsorber bank. For each charcoal adsorber, a two-stage temperature switch is provided. When the first-stage setpoint (200°F) is exceeded, it is alarmed on the main control panel and indicated on the local control panel. When the second-stage setpoint (310°F) is exceeded, it is annunciated on the local control panel. After the second-stage setpoint is reached, the deluge valve can be actuated manually. Actuation of the deluge valve is indicated in the main control room.

- j. Full-size access doors adjacent to each filter bank are provided in the equipment plenums. Access doors are provided with transparent portholes to allow inspection and maintenance of components without violating the train integrity. Spacing between filter sections is based on ease of maintenance considerations. The plenums are all-welded steel plate construction with intermediate concrete floors, heavily reinforced, and built to low leakage requirements.

6.5.1.2.3 Fuel Handling Building Exhaust System |

- a. The fuel handling building exhaust system works in conjunction with the auxiliary building ventilation system as described in Subsection 9.4.5.
- b. In the event of high radiation detection in the fuel handling building, the radiation monitoring system automatically routes the effluents through the charcoal adsorbers and booster fans (for removal of radioactive particulates and iodine) before they are exhausted outdoors.
- c. The fuel handling exhaust system as indicated in Drawing M-95 is common to both Units 1 and 2 and consists of the following in sequence:

1. Area radiation monitors located at the fuel pool in the fuel handling building.
 2. Two fuel handling building exhaust filter plenums connected in parallel.
 3. Auxiliary building exhaust plenum, four 50% capacity exhaust fans, and Unit 1 and 2 vent stacks are common with the auxiliary building exhaust plenum, as described in Subsection 6.5.1.2.2.
- d. Fuel handling building exhaust filter plenum

Each of the two fuel handling building exhaust filter plenums (FHBEFP) is identical and each has 100% of the capacity required to treat exhaust air from the fuel handling building, i.e., each plenum is designed to handle a nominal 21,000 cfm. Each FHBEFP consists of the following components:

1. An isolation damper.
 2. A high-efficiency prefilter.
 3. A HEPA filter.
 4. A bypass damper downstream of the HEPA filters which provides direct connection to the auxiliary building exhaust filter plenum, bypassing the charcoal adsorbers.
 5. Two 100% capacity charcoal adsorber plenums connected in parallel, each consisting of the following components:
 - a) A charcoal adsorber with fire protection provisions.
 - b) A HEPA filter.
 - c) An isolation damper.
 6. A nominal 21,000 cfm capacity charcoal booster fan. Each fan has a flow measuring element and a flow control damper downstream.
- e. The high-efficiency prefilters provided in the auxiliary building exhaust system are UL listed, all glass media, exhibiting no less than 85% efficiency based on ASHRAE 52.
- f. The high-efficiency particulate air (HEPA) filter provided in the auxiliary building exhaust system

is water resistant, capable of removing 99% minimum of particulate matter which is 0.3 micron or larger in size. The filter is designed to be fire resistant. Each element provided is rated for 1000 cfm. All elements are fabricated in accordance with NRC Health and Safety Bulletin 306, dated March 31, 1971, covering Military Specification MIL-F-51068 latest revision in effect at time of purchase, MIL-F-51079 latest revision in effect at time of purchase, UL-586, and after January 1995, AG-1 latest revision in effect at time of purchase.

- g. The charcoal adsorbers provided in the fuel handling building exhaust system are capable of removing not less than 90% of elemental iodine and 30% of organic iodide. The charcoal adsorbers are tray type and are filled with impregnated coconut shell charcoal. The charcoal adsorber beds hold charcoal of 30 lb/ft³ density with an ignition temperature of 340°C. Total bed depth is 2 inches.

The bed dimensions are so designed that the air has at least 0.25 second of residence time through the charcoal. The charcoal shall be of the best grade available at the time of installation and shall meet the requirements of ANSI N509-1976. Charcoal received after September 23, 1988 shall meet the requirements of ANSI N509-1980.

Ten test canisters are provided for each charcoal adsorber bank. These canisters contain the same depth of the same charcoal as in the charcoal adsorber. The canisters are so mounted that a parallel flow path is created between each canister and the charcoal adsorber. The charcoal in the canisters is thus subjected to the same contaminants as the charcoal in the bed. Periodically, one of the canisters is removed and laboratory tested to reverify the adsorbent efficiency.

- h. The fuel handling building charcoal filter bypass line is closed automatically on a high radiation signal from safety-related area monitors located in the fuel handling building. The bypass isolation dampers are also interlocked as follows: damper OVA051Y is interlocked with fan OVA04CA such that the damper will close when the fan is started, and similarly for damper OVA435Y and fan OVA04CB. The control and instrumentation for the interlock is shown on the same drawing as the charcoal booster fans.

- i. The fuel handling building exhaust system does not include a means for humidity control of the exhaust air prior to entering the charcoal filters. Exhaust air relative humidity will vary with the outside air conditions (temperature and relative humidity), the evaporation rate of the spent fuel pool water (water temperature), and the area heat generation. The relative humidity of the inlet air to the fuel handling building exhaust filter system may be greater than 70%. Therefore, laboratory testing is conducted at 30°C and 95% relative humidity and the removal efficiencies for the elemental and organic forms of radioiodine are 90% and 30% relatively.

THIS PAGE DELETED INTENTIONALLY.

- j. One deluge valve connected to the station fire protection system is mounted adjacent to each charcoal adsorber bank. For each charcoal adsorber, a two-stage temperature switch is provided. When the first-stage setpoint (200°) is exceeded, it is alarmed on the main control panel and indicated on the local control panel. When the second stage setpoint (310°) is exceeded, it is annunciated on the local control panel. After the second stage setpoint is reached, the deluge valve can be actuated manually. Actuation of the deluge valves is indicated in the main control room.
- k. Full-size access doors adjacent to each filter bank are provided in the equipment plenums. Access doors are provided with transparent portholes to allow inspection and maintenance of components without violating the train integrity. Spacing between filter sections is based on ease of maintenance considerations.

The plenums are all-welded steel plate construction with intermediate concrete floors, heavily reinforced, and built to low leakage requirements.

|

6.5.1.3 Design Evaluation

6.5.1.3.1 Emergency Makeup Air Filter Units

The emergency makeup air filter system works in conjunction with the control room HVAC system to maintain habitability in the control room. The design evaluation is given in Subsection 6.4.4.

6.5.1.3.2 Auxiliary Building Exhaust System

The auxiliary building exhaust system is designed to preclude direct exfiltration of contaminated air from the auxiliary building following an accident or abnormal occurrence which could result in abnormally high airborne radiation in the auxiliary building. Equipment is powered from essential buses, and all power circuits meet the requirements of IEEE 279-1971 and IEEE 308-1974. Redundant components are provided where necessary to ensure that a single failure will not impair or preclude system operation. A system failure analysis is given in Table 9.4-10.

6.5.1.3.3 Fuel Handling Building Exhaust System

The fuel handling building exhaust system is designed to preclude direct exfiltration of contaminated air from the fuel handling building, when required following an accident or abnormal occurrence which could result in abnormally high airborne radiation in the fuel handling building.

The fuel handling building will be maintained at a pressure of 0.25 inches (water) below atmospheric pressure. The basis for this requirement is the negative pressure differential indicated in SRP 6.2.3 Section II. The fuel handling building exhaust system will be under negative pressure at all times. The necessary airflow rates are as follows:

exhaust air - 21,000 cfm at 0.066 lb/ft³ density;

infiltration air - 4,070 cfm at 0.067 lb/ft³ density;
and

supply air - 16,135 cfm at 0.067 lb/ft³ density.

The control system has been modified to provide for a pressure differential controller sensing fuel handling building/outdoor differential pressure and controlling a modulating control damper in the air supply duct serving the fuel handling building.

Equipment is powered from essential buses, and all power circuits meet requirements of IEEE 279-1971 and IEEE 308-1974. Redundant components are provided where necessary to ensure

that a single failure does not impair or preclude the system operation. A system failure analysis is given in Table 9.4-10.

6.5.1.3.3.1 Fuel Handling Accident Inside Spent Fuel Storage Building

The accident is defined as the dropping of a spent fuel assembly in the spent fuel pool resulting in the rupture of the cladding of 264 fuel rods. The cause of the event can be identified as any mechanical failure or operating error which results in the dropping of a fuel assembly into the refueling pool during its transfer from one position in the pool to another. The frequency classification, as defined in Regulatory Guide 1.70, can be categorized as one of limiting faults. This means that it is an occurrence that is not expected to occur but is postulated because its consequences would include the potential for the release of significant amounts of radioactive material. The step-by-step sequence of events from initiation to the final stabilized condition is described in Table 6.5-2. For the purpose of this accident, the time sequence will be referenced from the moment radioactivity is released from the surface of the pool water.

As originally designed, least 12 seconds would be required for radioactivity to travel from the exhaust inlet to the first isolation damper. Thus, all activity released from the accident could be filtered through HEPA and charcoal filters prior to release to the stack. However, design basis analyses performed utilizing alternative source term methodology do not credit filtration.

During handling of recently irradiated fuel (i.e. fuel that has occupied part of a critical core within the previous 48 hours), the fuel handling building ventilation system is required to be operable. The normal supply system is designed to provide 19,050 cfm of outside air to the fuel handling building general area. The exhaust inlets are located at the pool edge. The shortest distance between the exhaust inlets and the inboard isolation valve is 222 feet.

Redundant GM-type gamma detectors are mounted on the walls near the edge of the pool to provide reliable and rapid detection of radioactivity released from the pool surface. If predetermined levels are exceeded, the monitors alarm locally and in the main control room and initiate control action to route the released activity through the emergency exhaust system. However, design basis analyses performed utilizing alternative source term methodology do not credit filtration.

The monitors have an operating range which extends from 0.1 to 10^4 mR/hr. The lower range level is chosen to assure that normal operating levels are on scale (provides indication that the instrument is operational). Operating levels below 0.1 or greater than 50 mR/hr are unlikely. Initial setpoints are listed in Table 12.3-3.

The worst case fuel handling accident (as originally analyzed) has the potential of exceeding the 10 R/hr maximum range of the fuel handling accident monitors, but this environment will not prevent the monitor from completing its design function. General Atomics (GA) has tested this monitor to 500 R/hr, and based on this

test, they have determined that this monitor will perform its function up to 1000 R/hr.

The monitor was originally selected to assure initiation of control action within 6 seconds or less. Commercially available area monitors are suitable for this application.

Two separate and independent (nuclear safety-related) monitors are provided for the spent fuel pool. Two nuclear safety-related recorders are provided in the control room for the spent fuel pool.

6.5.1.4 Tests and Inspections

The engineered safety feature filter systems and their components are thoroughly tested in a program consisting of the following:

- a. factory and component qualification tests,
- b. onsite preoperational and filter acceptance testing, and
- c. onsite periodic testing.

Written test procedures establish minimum acceptable values for all tests. Test results are recorded as a matter of performance record, thus enabling early detection of reduced performance.

The factory and component qualification tests consist of the following:

- a. equipment train housing - a leak test and magnetic particle or liquid penetrant testing per Section III of ASME Boiler and Pressure Vessel Code of all welds which could cause bypass leakage around HEPA filters or adsorber beds;
- b. demister - qualification test or objective evidence to demonstrate compliance with specified design criteria;
- c. HEPA filters - elements tested individually by the manufacturer in accordance with the requirements of Regulatory Guide 1.52.

- d. HEPA filter and charcoal adsorber mounting frames-leak test across filterless, covered bank;
- e. adsorbent beds - model test of bed or objective evidence to demonstrate flow pressure characteristics and channeling effects;
- f. adsorbent - qualification tests per ANSI N509-1976, after September 23, 1988 qualification tests per ANSI N509-1980;
- g. fans - tested in accordance with the latest revision of AMCA 210, "Air Moving and Conditioning Association Test Code for Air Moving Devices," to establish characteristic curves, etc.;
- h. heater - uniform temperature test, high-temperature cutout test, and entering and leaving air temperature test;
- i. prefilter - objective evidence or certification that American Society of Heating, Refrigeration and Air Conditioning Engineers (ASHRAE) efficiency specified is attained; and
- j. dampers - shop tests demonstrating leak-tightness and closure times.

The onsite preoperational and filter acceptance tests are discussed in Section 14.2.

Operating personnel are trained and required to make surveillance checks. These checks shall include visual inspection and periodically running the equipment trains for performance testing as outlined in the Technical Specifications.

6.5.1.5 Instrumentation Requirements

High differential pressure across the upstream and downstream HEPA filter is alarmed on the local control panel. One high filter differential pressure alarm for each plenum is provided on the main control panel.

For each charcoal adsorber, a two stage temperature switch is provided. When the first stage setpoint (200°) is exceeded, it is alarmed on the main control panel and indicated on the local control panel. When the second-stage setpoint (310°F) is exceeded, it is annunciated on the local control panel. One deluge valve for each charcoal adsorber bed is provided which can be opened manually when the second-stage setpoint is reached.

Flow signals are transmitted to the local control panel for indication and for modulation of the control damper.

Remote manual operation is provided on the main control board for each fan.

Design details and logic of the instrumentation are discussed in Subsections 7.3.1.1.8 and 7.3.1.1.9.

6.5.1.6 Materials

All component material is capable of a service life of 40 years normal operation plus 6 months post-LOCA at the maximum cumulative radiation exposure without any adverse effects on service, performance, or operation. All materials of construction are compatible with the radiation exposure set forth. This includes but is not limited to all metal components, seals, gaskets, lubricants, and finishes, such as paints, etc.

Care is taken to avoid the use of any compounds or other chemicals during fabrication or production that contain chlorides or other constituents capable of inducing stress corrosion in stainless steels which are used in the adsorber bed.

All components, including the housings, shall be designed in accordance with the applicable pressure and temperature conditions.

All gaskets and seal pads are closed-cell, ozone-resistant, oil-resistant neoprene or silicone-rubber sponge, Grade SCE-43 or current designation at time of purchase in accordance with ASTM D1056.

Only adhesives as listed and approved under AEC Health and Safety Bulletin 306, dated March 31, 1971, covering Military Specification MIL-F-51068C, dated June 8, 1970, and all the latest amendments and modifications are used.

The organic compounds included in the filter train are as follows:

- a. charcoal;
- b. the binder in the HEPA filter media;
- c. adhesive used in HEPA filters - approximately 1 liquid quart of fire-retardant neoprene or polyurethane foam adhesive is used to manufacture each HEPA filter;
- d. neoprene gaskets used on HEPA filters and charcoal filter tray flanges;
- e. the binder in the glass pads used in the demister section (this is a phenolic compound); and

- f. phenolic compounds and elastomers associated with electrical components.

6.5.2 Containment Spray Systems

The containment spray systems are designed to remove fission products, primarily iodine, from the containment atmosphere for the purpose of minimizing the offsite radiological consequences following the design-basis loss-of-coolant accident. At the same time, the spray water serves to nominally reduce containment temperature and pressure during the injection phase.

The containment spray systems may be used to mix the contents of the RWST prior to chemistry sampling. This is accomplished by lining up the containment spray system for recirculation to the RWST. This lineup is identical to the one used to test the containment spray pumps and may be performed in any mode.

The containment spray systems may also be used to transfer borated water from the refueling cavity and transfer canal to the RWST. This is accomplished by taking suction from an RCS hot leg via RHR piping and discharging to the RWST via the containment spray system recirculation piping. This evolution can only be performed when the reactor core is defueled.

6.5.2.1 Design Bases

The containment spray system is designed to reduce the pressure in the containment atmosphere at a rate which will ensure that the design leakage is not exceeded and to remove sufficient iodine from the containment atmosphere to limit, in the unlikely event of a LOCA, the offsite and site boundary doses to values below those set by 10 CFR 50.67.

The spray system is designed to provide a sufficient quantity of 30% to 36% NaOH solution to the containment to form an 8.0-10.5 pH solution when combined with the spilled reactor coolant water, the safety injection accumulator inventory, and the refueling water storage tank inventory. The containment spray system consists of two entirely independent subsystems such that the aforementioned requirements can be met in the event of a single active failure in either of the subsystems.

All components of the containment spray system except the test/recirculating line are Safety Category I and Quality Group B and are protected from missiles which could result from a loss-of-coolant accident. All risers and ring headers are supported to withstand loads resulting from the safe shutdown earthquake as well as operating loads. A seismic dynamic analysis has been performed on the system.

The following criteria apply to the spray nozzles:

- a. The Sauter (surface to volume ratio) mean diameter of the spray drops produced by the nozzle at the design pressure drop across the nozzle must be approximately 1000 microns or less.
- b. The pressure nozzle used is of a swirl chamber design, without any internal parts, such as swirl vanes, etc., which would be subject to clogging.
- c. Flow through the nozzle at the design operating point is at least 15 gpm. Lower nozzle flow due to degraded pump performance combined with limiting vacuum conditions in the RWST has been evaluated and is acceptable.

6.5.2.2 System Design (for Fission Product Removal)

The containment spray system has been divided into two independent 100% capacity pumping systems with no common headers. A single active failure in either of the two pumping systems will therefore not affect the operation of the other subsystem. A single-failure analysis is presented in Table 6.5-1. The system diagram (Drawing M-46) illustrates equipment redundancy, flowpaths, and system operation.

The containment spray system includes six ring-type spray headers each having the following radii, pipe diameter, number of nozzles, and served by the pump indicated:

Ring Number	Mean Radius	Nominal Pipe Diameter in.	Number of Nozzles	Destination of Pump Delivering Fluid to the Ring
1	13 feet 0 inch	4	39	"A" Pump
2	23 feet 6 inches	6	51	"B" Pump
3	34 feet 1/2 inch	6	60	"A" Pump
4	45 feet 9 inches	6	90	"B" Pump
5	56 feet 7-1/2 inches	8	120	"A" Pump
6	64 feet 9 inches	8	112	"B" Pump

There are no cross connections between the "A" and "B" spray headers. Rings 1, 3, and 5 are supplied via a single 10-inch riser pipe with restricting orifices in laterals supplying rings 3 and 5 to assure that the flow to each ring is proportionate to the number of nozzles supplied. Similarly, rings 2, 4, and 6 are supplied via a single 10-inch riser pipe with restricting flow orifices in laterals supplying rings 4 and 6. The plan view of the spray headers showing nozzle location and orientation is given in Drawing M-535, Sheets 3-5.

The "A" pump is nominally designed to deliver 15 gpm to each of 219 spray nozzles, plus approximately 130 gpm of motive fluid to the eductor considering post-accident containment pressure versus RWST level time profiles and pump degradation. The "B" pump under like conditions is nominally designed to deliver 15 gpm to each of 253 spray nozzles plus approximately 130 gpm of motive fluid to the eductor. The nominal pump ratings are therefore 3415 and 3925 gpm for the "A" and "B" pumps respectively, at 450 feet total developed head.

In the event of a high-high-high (Hi-3) containment pressure signal (corresponding to approximately 20 psig), the CS007, the CS019,

and the CS010 valves will open immediately if they are not previously in the open position; the CS pumps will start immediately once the CS019 valve is open, provided that offsite power to the ESF buses has not been lost. Otherwise, upon receipt of a safety injection signal and restoration of bus voltage, the containment spray pumps will be sequenced to start by the diesel engine generator load sequencer, providing the Hi-3 signal is present and the CS019 valve is open. The valve motor operators will start immediately upon receipt of an Hi-3 signal if power is available.

The refueling water storage tank (RWST) (containing 2300 to 2500 ppm of boron) for each unit has a capacity of approximately 458,000 gallons. Low-level switches are provided to automatically open the containment sump isolation valves, SI8811 A and B, on two out-of-four logic sensing a Lo-2 level with the presence of a safety injection signal. It should be noted that manual reset of safety injection does not defeat the automatic opening of the SI8811 A and B valves. The RHR pumps are thereby transferred to the recirculation mode automatically without stopping them. The charging pumps and safety injection pumps are then manually changed to the recirculating mode (see Subsection 6.3.2.8). The containment spray pump continues to take suction from the RWST until the Lo-3 level is reached. The CS pump suction is then manually transferred to the recirculation sump. NaOH addition continues, regardless of pump suction source, until the spray additive tank Lo-2 level is reached. The spray additive tank is then manually isolated from the CS eductor.

Heat tracing the spray additive tanks and piping is not necessary to prevent crystallization of the 30% to 36% sodium hydroxide solution. The spray additive tank also has a nominal 1 psig nitrogen cover blanket applied to eliminate ambient air contact with the solution.

The worst-case condition for maximum spray pH postulates the failure of one CS019 valve to open concurrently with two trains of ECCS and CS pump in operation. Since the spray additive tank is supplying only one eductor, the time to deplete the spray additive tank is greater than the time to deplete the RWST. This will result in transferring the suction of the CS pump to the containment recirculation sump and continuing eduction of NaOH from the spray additive tank until the spray additive tank Lo-2 level is reached. This will result in NaOH being added to sump water that already contains NaOH. At this time, the resulting pH may exceed 10.5. However, this is acceptable with regard to the equipment qualification limit of 10.5 (see Subsection 3.11.5) and for hydrogen generation purposes.

Attachment A6.5 describes the Iodine removal effectiveness of the Containment Spray System.

Sufficient NaOH is delivered to the containment to form a minimum 8.0 pH sump solution when ECCS injection fluid (from the refueling water storage tanks and accumulators) is combined with spilled reactor coolant. This final sump pH will provide for long-term iodine retention. This will result in a decontamination factor of 200 in the containment atmosphere for sump temperatures between 150 °F and 212 °F.

Regulatory Guide 1.1 addresses the recirculation mode in which temperatures of the pumped fluid are at a maximum. The recirculation mode dictates the design for residual heat removal and containment spray pump suction piping because during the injection phase there is 50 to 90 feet of positive head available from the refueling water storage tank acting on the suction of these pumps.

The residual heat removal pumps require approximately 12 feet of NPSH at 3000 gal/min design capacity and approximately 19 feet of NPSH at runout capacity of 5000 gal/min. The containment spray "B" pump requires approximately 19 feet of NPSH at 3925 gal/min design capacity and approximately 22 feet of NPSH at 4600 gal/min runout capacity. Since the "B" train containment spray pump is of higher capacity than the "A" train pump, and the line size and equivalent feet of pipe are about the same for both the trains, for containment spray, the NPSH required versus available is most critical for the "B" train pump. Values of NPSH required are indicated as approximate because there are slight variations between pumps of duplicate design.

Allowing no credit for the water standing in the basement of the containment but assuming that the recirculation sump is full, the static head available is in excess of 30 feet for the containment spray pumps (containment basement elevation minus elevation of the centerline of the containment spray pumps) and in excess of 29 feet for the RHR pumps (containment basement elevation minus elevation of the centerline of RHR pumps).

Based upon both the RHR and containment spray "B" Pump operating under runout conditions, friction losses between the sump and pump inlet are conservatively calculated to be less than 3.5 feet for containment spray and for RHR. The minimum resultant NPSH available is approximately 29 feet for the containment spray "B" pump and approximately 28 feet for the RHR pumps.

For high temperature conditions, this analysis assumes that the liquid in the recirculation sump is at its vapor pressure at all times, thus there is no need to deliberately continue a high containment pressure condition to satisfy pump NPSH requirements. As part of the chemical effects evaluations related to head loss through the containment recirculation sump strainers (in support of Generic Letter 2004-02), the NPSH analysis for the RHR pumps has been performed at low temperatures.

In accordance with the requirements specified in Regulatory Guide 1.1, the NPSH analysis at low temperatures assumes the containment atmospheric pressure is equal to the minimum containment atmospheric pressure that would be present inside containment before the Loss of Coolant Accident (LOCA) event. This analysis does not credit calculated increases in containment pressure as a result of the LOCA.

Adequate net positive suction head is available to the RHR pumps.

The sump solution satisfies NPSH requirements of the pumps with adequate margin to assure satisfactory pump operation concurrent with RHR pump runout at the rate of 5000 gpm and CS pump maximum flow of 4800 gpm.

Containment sump water temperature is not monitored for postaccident analysis. Although identified in Regulatory Guide 1.97 as an important parameter, containment sump water temperature indication would only be useful to determine if adequate NPSH is available to the CS or RHR pumps during the recirculation mode. By design, cavitation of these pumps will not occur even at containment saturation peak water temperature. The B/B design complies with Regulatory Guide 1.1 which states that, "Emergency core cooling and containment heat removal systems should be designed so that adequate net positive suction head (NPSH) is provided to system pumps assuming maximum expected temperatures of pumped fluids and no increase in containment pressure from that present prior to postulated loss of coolant accidents." Containment sump water temperature is therefore not a parameter required to indicate proper operation of the CS or RHR systems when in the recirculation mode.

Containment spray operation will continue for a minimum of 8 hours following a LOCA. After 8 hours of operation, containment spray may be terminated if containment pressure is less than 15 psig and the spray additive tank has reached the Lo-2 level.

Following a MSLB, containment spray operation may be terminated after containment pressure is less than 15 psig. NaOH addition may be secured prior to 15 psig.

Suction lines to each pump are provided with guard pipes and suction valve protection chambers up to and including the first valve outside the containment for passive failure protection.

Both pumps and all motor-operated valves are supplied with power from the emergency diesel generators in the event of a loss of offsite power. Failure of a single diesel generator or emergency bus will affect one subsystem only.

Spray Engineering Company of Burlington, Massachusetts, 1713A nozzles meet the requirements stated in the design basis. The following listed figures illustrate the characteristics of this nozzle when spraying into a chamber at atmospheric pressure and normal ambient temperature and humidity:

- a. Figure 6.5-5, Diameter of spray envelope versus height when spraying vertically downward.
- b. Figure 6.5-6, Diameter of spray envelope versus height when spraying horizontally.
- c. Figure 6.5-7, Diameter of spray envelope versus height when spraying downward at a 45° angle.

The above figures are predicated upon a 40 psi drop across each nozzle with a resulting flow of 15.2 gpm per nozzle. Pressure versus flow characteristics of this nozzle are illustrated in Figure 6.5-8.

In determining the number of spray nozzles required and their configuration, the effects of density of the containment atmosphere must be considered. The reduction factors to be applied to spray envelope diameter as a function of containment saturation temperature are shown in Figure 6.5-9.

To prevent degradation of the sodium hydroxide, an inert atmosphere is maintained within the spray additive tank by means of a nominal 1 psig nitrogen blanket. A relief valve is provided to prevent overpressurization of the tank.

B/B-UFSAR

The components for this system are as follows:

a. Containment Spray Pumps

Number - two per unit

Type - Vertical centrifugal

Material - Stainless steel

Capacity "A" pump - 3415 gpm

Capacity "B" pump - 3925 gpm

Net developed head - 450 feet

b. Spray Additive Tank

Number - one per unit
Material - Stainless steel
Volume - 5000 gallons
Fluid - 30% to 36% NaOH in water
Cover gas - Nitrogen
Design pressure - 1.3 psig
Design temperature - 100°F

c. Eductors

Number - two per unit
Design Pressure - approximately 300 psig
Design Temperature - 300°F
Design flow - 130 gpm at pressure connection
(actual flow rate was determined
during preoperational testing)

Design
educted flow - 25-60 gpm 30% NaOH at
suction connection (for pH
control)

Material - Stainless steel

d. Spray Nozzles

Material - Stainless steel
Type - Sprayco

6.5.2.3 Design Evaluation

An extensive research and development program has been conducted as part of the NRC's Reactor Safety Program to determine the iodine removal effectiveness of the chemical spray systems. Containment spray experiments were performed in the 1350 ft³ vessel of the Nuclear Safety Pilot Plant (NSPP) at ORNL and were supported by additional containment spray experiments in the large 25-foot-diameter by 66.7-foot-high (26,500 ft³) vessel (approximately one-fifth the scale of a typical 1000 MWe nuclear reactor) of the Containment Systems Experiment (CSE) at BNWL. Since the containment spray tests

were begun, the iodine-removal capability of spray systems has been well established by over 80 spray tests in the NSPP and 28 spray tests in the eight CSE experiments.

The verification of the containment spray system spray coverage within the containment and system design parameters has been completed at the Zion Station. The experimental verification of the acceptability of the containment spray system as a viable means of rapidly removing iodine from the containment has been completed by Westinghouse Electric Corporation and reported in WCAP-7742 and other publications. The adequacy of sodium hydroxide spray additive has been documented in various ORNL and BNWL reports.

The extensive research on the behavior of iodine in accident environments and the dose reduction factors provided by containment spray systems has been completed, and the conclusion is that the containment spray system is an effective safety system which has been proven by experimental studies and large scale model tests.

One of the advantages of the sodium hydroxide spray system is that it responds rapidly by starting to clean all the gas in the containment after an accident by absorbing and reacting with the airborne iodine. Other types of iodine-removal systems respond much more slowly and thus permit the iodine to remain airborne for a longer time. In comparison to other systems, the spray system is much simpler in design. It utilizes system components which are reliable and well understood through extensive use. The fission product removal capability is discussed in detail in Attachment A6.5.

The following sections of the containment will not be directly covered during postaccident spray operation:

- a. containment fan cooler discharge structures,
- b. missile barrier passageways,
- c. chamber beneath upper internals storage area,
- d. chamber beneath lower internals storage area,
- e. chamber beneath exchange fixture storage area,
- f. chamber beneath transfer tube,
- g. passageways above transfer tube,
- h. entrance to seal table,
- i. volume beneath main steamline penetrations,

- j. volumes beneath floor slabs at elevation 426 outside the missile barriers.
- k. volume operating floor,
- l. chamber beneath pressurizer,
- m. chambers beneath steam generators
- n. sheltered volumes beneath seal table and heat exchanger compartments,
- o. net free volume within seal table and heat exchanger compartments, and
- p. net free volume within the reactor vessel cavity and in-core instrument shaft.

The maximum net containment volume is 2,848,387 ft³; the minimum net containment volume is 2,758,850 ft³. The minimum net volume of the containment which is sprayed directly is 2,349,944 ft³, or 82.50% of the maximum net volume and 85.18% of the minimum net volume. The regions not directly sprayed but having good communication with sprayed regions have a maximum volume of 438,914 ft³ and a minimum of 349,377 ft³, or 15.41% of maximum and 12.66% of minimum net containment volume.

The minimum net volume that is sprayed directly includes the volume above the operating floor minus: the polar crane; steam generator; pressurizer; and reactor coolant pump compartments; and plus: the refueling cavity; main steam vertical pipe chase; regenerative and excess letdown heat exchanger compartments.

There are no regions within the containment that are unsprayed and not in communication with sprayed volumes within the containment. The seal table compartment, with a net volume of 3146 ft³, and the reactor coolant drain tank compartment, with a net volume of 341 ft³, have poor communication with the sprayed regions of the containment, for a total of 3487 ft³. This is 0.122% of the maximum net containment volume and 0.126% minimum net containment volume.

Under post-LOCA conditions, there is 56,042 ft³ of water in the containment basement. This plus the directly sprayed regions plus the seal table and reactor coolant drain tank compartment totals are equal to 2,409,473 ft³. The regions not directly sprayed but having good communication with sprayed volumes are by difference a maximum 438,914 ft³ and a minimum of 349,377 ft³, or 15.41% and 12.66% of maximum and minimum net containment volume. The 56,042 ft³ of water in the containment basement corresponds to a water level of 5 feet 2 inches. The maximum evaluated flood level of 6 feet 3 inches has minimal effect on

these containment region volumes. The change to the maximum/minimum volumes is less than 0.1% for the regions not directly sprayed but having good communication with sprayed volumes.

The containment spray pumps will be run for at least 8 hours following a LOCA. During this time, switchover of pump suction

from the injection to the recirculation mode of operation will be manually initiated and completed.

The containment spray pumps do not have to be stopped when transferring from the injection mode to the recirculation mode of operation, provided that the RWST has not reached the empty level. A summary of the sequence of events leading up to and during switchover follows.

The RWST level is initially one volume inaccuracy below the low alarm setpoint. ECCS switchover is initiated when the RWST Lo-2 alarm annunciates. This is discussed in Section 6.3.

Spray switchover is initiated when the RWST Lo-3 alarm annunciates. Upon recognition of the RWST Lo-3 alarm, the operator opens the CS009 valve and closes the CS001 valve. At this time all ECCS and containment spray pumps have a long-term suction supply of water.

Upon initiation of containment spray, the operator monitors the spray additive tank level; on a LO-2 level, the containment spray eductor spray additive valve for each operating train is closed. In the event of a single failure of the containment spray eductor spray additive valve to open, the pump in the train with the failed valve will not autostart. While the ECCS pumps are operating from the recirculation sump, the one operating spray pump continues to take suction from the RWST until the RWST reaches the Lo-3 level. At this time the spray pump suction is switched to the recirculation sump.

Addition of required volume between Lo to Lo-2 level setpoints of 30-36% NaOH from the spray additive tank to the containment results in a minimum sump pH of 8.0 which is above the minimum required sump pH of 7.0 to ensure Iodine retention. This is accomplished by continuing caustic addition while the spray pump is taking suction from the sump.

At the initiation of containment spray, the CS pumps take suction from the RWST. The resulting pH of the RWST and NaOH mixture may exceed the upper EQ limit of 10.5 depending on the CSAT NaOH concentration. When the CS pumps are aligned to take suction from the containment sump, the eductors may still be in operation, adding NaOH to the pump flow. This will result in a maximum spray pH. When NaOH addition is secured and the CS pump suction is from the recirculation sump, the spray pH will be the same as the sump pH (8.0-10.5). The effects of these pH values on equipment qualification and hydrogen generation have been evaluated and found acceptable. Below is a detailed description of the effects on pH caused by the CS system operation.

At the initiation of containment spray, water from the RWST is mixed with NaOH from the spray additive tank. The pH of the mixture is determined primarily by the concentration of NaOH in the spray additive tank. If the CSAT is at the upper concentration limit and the NaOH flow is at the upper limit, the resulting pH may be greater than the EQ limit of 10.5. When the source of containment spray water is switched from the RWST to the recirculation sump (LOCA only), the eductor may be adding NaOH to sump water that has already been treated with NaOH. This will cause the pH to increase. The increase is determined by the actual flow rates before and present at the time of switchover. However, this value is bounded by the pH that occurs in the final minute of NaOH addition, when it is assumed that all the NaOH previously added had mixed uniformly and flowed to the recirculation sump. The duration of increased pH is determined by the number of trains of ECCS and CS pumps in operation.

Equipment qualification of components in containment was performed assuming a maximum spray pH of 10.5 at 77°F. The pH described above has been reviewed concerning hydrogen generation and equipment qualification and has been found acceptable. Refer to Section 3.11.5.

Operator Actions

The parameter used by the operator to determine when to initiate containment spray suction transfer to the recirculation sump is the RWST level.

Eductor flows are stopped when the spray additive tank level indicates that the required amount of NaOH has been added to achieve the required final pH in the containment sump. This ensures the required volume of 30% to 36% NaOH is added. There is a status lamp indicator to show when the low-low level has been reached. There is also an annunciator alarm. This quantity ensures that the required pH is achieved under worst case conditions of maximum reactor coolant and RWST boration. In the case where the spray additive Lo-2 level alarm does not initiate before the RWST Lo-3 alarm initiates, spray switchover is initiated when the RWST Lo-3 alarm initiates, and NaOH addition continues until the spray additive tank Lo-2 level is reached.

Two series of operations are required to be accomplished by the operator to complete spray switchover: opening of the containment spray pump suction valve to the recirculation sump; and, closing of the containment spray pump suction valve to the RWST.

6.5.2.4 Tests and Inspections

6.5.2.4.1 Preoperational Test Program

The preoperational test program has been conducted. The pump discharge was routed through the test recirculating line back to the refueling water storage tank (RWST) or routed directly into the refueling cavity inside containment. The valve operating and pump starting times, the pump and eductor delivery rates, and valves adjusted to ensure proper flows through the eductors, were recorded. The eductors were tested with demineralized water instead of sodium hydroxide, and the test values were adjusted for the appropriate sodium hydroxide flow rates. The actual eductor motive fluid flow rates were determined at this time.

6.5.2.4.2 Reliability Tests and Inspections

Routine periodic testing of the containment spray components and support systems are performed per ASME Section XI requirements. Remote operated valves are cycled to verify operability and inspected for leakage. The pumps are tested using the recirculation line to the RWST.

To implement the periodic component testing requirements, Technical Specifications have been established.

These tests verify valve position and actuation, pump performance and actuation, spray additive tank level and concentration, spray nozzle flow path, and NaOH addition rate.

The NaOH addition rate is verified by using the primary water system to simulate the spray additive tank level at the eductor suction. The tank level is simulated at the high level alarm setpoint. In addition, the eductor motive fluid flow rate, as determined in the full-flow preoperational tests, is established. Under these conditions, the equivalent containment spray additive flow rate is verified to be adequate to ensure transfer of the CSAT inventory to the containment recirculation sump while limiting spray pH to values consistent with existing equipment environmental qualification constraints.

During periodic system testing, a visual inspection of pump seals, valve packings, flanged connections and relief valves is made to detect leakage and confirm that no significant deterioration is occurring in the containment spray system.

All testing of the containment spray system components may be done while the unit is in operation except for air testing of the nozzles, which should be accomplished when the reactor is shut down.

In addition, in response to NRC Generic Letter 95-07, "Pressure Locking and Thermal Binding of Safety-Related Power-Operated Gate Valves," the following administrative procedural control was implemented to ensure continued reliability of the following containment spray valves:

- The containment spray pump discharge isolation valves, 1(2)CS007A/B, are cycled following evolutions that could potentially create a pressure-locking condition.

6.5.2.5 Instrumentation Requirements

The containment spray system is provided with the instrumentation and controls to permit the monitoring and actuation of the system from outside the containment.

The containment spray pumps and motor-operated valves can be actuated either automatically or manually. Automatic actuation signals are generated in the solid-state protection system cabinets. Both spray subsystems will be actuated by a Hi-3 containment spray signal. Actuation includes starting both pumps, and opening all valves required for system operation. Manual actuation is from control switches on the main control board.

Indicating lights are provided on the main control board and on the ESF status panels to show the status of the pumps and the position of the valves. Main control board monitor lights are provided to show the status of the pumps and valves as an operator aid in evaluating system response subsequent to automatic safeguard actuation. Alarms on the main control board are provided for pump automatic trip, pump automatic start, pump fail to start and valves fail to open.

Refueling water storage tank level is indicated on the main control board, and alarms are provided for high, low, low-low, and low-low-low tank levels.

Spray additive tank level is indicated locally and on the main control board. Alarms are provided for high, low, and low-low tank levels. There is also a status lamp indicator and annunciator for low-low tank level located on the main control board.

During testing, either adjustable manual valves CS018A or CS021A and CS018B or CS021B in the caustic line are set (utilizing water and correcting for specific gravity) and locked in position at the desired 30% NaOH rate of flow to the eductor. In addition, the actual motive fluid flow rate to the eductor for each spray system was determined during preoperational testing. These flow rates are used during periodic system testing. Main control board flow indicators are provided for pump discharge, pump to eductor recirculation, and eductor NaOH suction, and an alarm is provided for NaOH injection flow failure. The temperature of the pump motor bearings is monitored. Ammeters are provided on the main control board to monitor motor current.

Design details of the containment spray controls and instrumentation are presented in Section 7.3.

6.5.2.6 Materials

All components in the containment spray system which come into contact with spray solution during either the injection or recirculation phase are fabricated of stainless steel. All containment materials are compatible with the NaOH solution with the exception of galvanized steel and aluminum. These materials are discussed in Subsection 6.2.5.

6.5.3 Fission Product Control Systems

The primary containment fission product control systems during normal plant operating conditions consist of the containment charcoal filter units and the containment miniflow purge system. For further discussion of these systems, refer to Subsections 9.4.8 and 9.4.9.

The system which operates following a design-basis accident to remove fission products is the containment spray system. For further discussion of this system, refer to Subsection 6.5.2.

Note that the charcoal has been removed from the containment charcoal filter units on Byron Unit 2.

Note that the containment charcoal filter units at Braidwood Station have been abandoned in place.

TABLE 6.5-1

SINGLE ACTIVE FAILURE ANALYSIS - CONTAINMENT SPRAY SYSTEM

COMPONENT	MALFUNCTION	COMMENTS
Refueling water storage tank	None	Passive component, active failure not credible.
Spray additive tank	None	Passive component, active failure not credible.
Containment spray pumps	Failure to start	Two provided, each with a separate power supply. Evaluation based on one operating.
Eductors	None	Passive component, active failure not credible.
Automatically operated valves		
1. Spray additive tank outlet	Failure to open	Separate lines to each train
2. Spray pump discharge	Failure to open	Redundant trains

(RECIRCULATION PHASE ONLY)

FLOW PATH	INDICATION OF LOSS OF FLOW PATH	ALTERNATE FLOW PATH
Containment spray subsystem	Indication not required.	Alternate spray subsystem.
Pump suction from sump up to and including isolation valve.	Indication not required. Guard pipe or valve chamber will assure pump suction.	--

TABLE 6.5-2

FUEL HANDLING ACCIDENT INSIDE SPENT FUEL STORAGE BUILDING

EVENT	TIME
<p>1. A fuel assembly is being handled by refueling equipment. The assembly drops onto the top of the spent fuel storage racks or pool floor during fuel transfer. Some of the fuel rods in both the dropped assembly and/or the spent storage racks are damaged, resulting in the release of radioactive noble gas and gaseous iodine to the spent fuel pool water.</p> <p>The gaseous activity rises as a bubble(s) and reaches the pool surface partially depleted in iodine.</p>	0 second
<p>2. The nuclear safety-related monitors near the pool begin to detect the gamma radiation as the gas reaches and emerges from the pool surface.</p>	0 second
<p>3. The radioactive bubble(s) disperses and mixes with the air above the pool surface and begins to move towards the exhaust inlets located at the pool edge. There are 31 exhaust inlets around the pool located 5 inches above the pool surface.</p>	
<p>4. The monitor sends a signal to close the normal HVAC system isolation dampers and open the dampers on the emergency exhaust filter train.</p>	6 seconds
<p>5. The isolation dampers are closed and the dampers on the emergency exhaust filter train are opened routing air through HEPA and charcoal filters (5 seconds or less total).</p>	11 seconds

Tables 6.5-3 and 6.5-4 have been deleted intentionally.

TABLE 6.5-5

NONACCESSIBLE AREAS OF THE AUXILIARY BUILDING

AREA		PLANT FLOOR ELEVATION
Units 1 and 2	Floor Drain Sump Rooms	
Units 1 and 2	Equipment Drain Pump Rooms	
Units 1 and 2	Residual Heat Removal Pumps A and B Rooms	
Units 1 and 2	Containment Spray Pumps A and B Rooms	
Recycle Evaporators OA, OB Rooms		
Recycle Evaporator Feed Pumps OA, OB Rooms, and Recycle Evaporator Feed Pumps Valve Aisles		Security - Related Information Figure Withheld Under 10 CFR 2.390
Units 1 and 2	Collection Drain Sump Room (Byron)	
Unit 1	Collection Drain Sump Room (Braidwood)	
Unit 2	Collection Drain Sump Room/ Hot Machine Shop (Braidwood)	
Gas Decay Tank Rooms		
Gas Decay Tank Valve Aisle		
Recycle Holdup Tank Pipe Tunnel and Tank OA Room		
Gas Decay Tank and Recycle Evaporator Pipe Tunnel		
Units 1 and 2	Residual Heat Exchanger Rooms A and B	
Units 1 and 2	CASP Areas	
Units 1 and 2	Safety Injection Pumps A and B Rooms	
Units 1 and 2	Positive Displacement Charging Pump Room	
Units 1 and 2	Centrifugal Charging Pumps A and B Rooms	

B/B-UFSAR

TABLE 6.5-5 (Cont'd)

AREA	PLANT FLOOR ELEVATION
Units 1 and 2 Spray Additive Tank Room and Pipe Penetration Area	
Units 1 and 2 Pipe Tunnels	
HRSS Lab Area, HRSS Tank and Pump Room	
Units 1 and 2 Heat Exchanger Valve Aisles	
Radwaste and Blowdown Mixed Bed Demineralizer Valve Aisle	
Radwaste Mixed Bed Demineralizer OA, OB and OC Cubicles	
Units 1 and 2 Filter Valve Aisle, Operating Area, Pipe Tunnel and Associated Filter Cubicles	
Blowdown Mixed Bed Demineralizer OA, OB, and OC and OD Cubicles	
Radwaste and Blowdown Mixed Bed Demineralizer Valve Aisle and Operating Area	
Units 1 and 2 Heat Exchanger Valve Operating Area	
Aux. Steam Pipe Tunnels	Security - Related Information Figure Withheld Under 10 CFR 2.390
Units 1 and 2 Pipe Tunnels	
Spent Resin and Concentrate Pump Rooms	
Radwaste Distillate Condensers Rooms A, B, C	
Units 1 and 2 Demin. Valve Aisle, Pipe Tunnel and Associated Filter Cubicles	
Surface Condenser Rooms A, B and C	
Radwaste Evaporator Rooms A, B and C	
Radwaste Gas Compressors OA, OB Rooms	

B/B-UFSAR

TABLE 6.5-5 (Cont'd)

AREA	PLANT FLOOR ELEVATION
Clothes Change and Shower Room (Byron only)	Security - Related
Mask Cleaning Room (Braidwood only)	Information Figure Withheld
Gas Analyzer Cabinet Aisle	Under 10 CFR 2.390
Units 1 and 2 Volume Control Tank Rooms and Valve Aisle	
Waste Gas Analyzer Rack Area	

ATTACHMENT A6.5

IODINE REMOVAL EFFECTIVENESS EVALUATION

OF CONTAINMENT SPRAY SYSTEM

Following a postulated Loss-of-Coolant Accident, the containment spray system functions to remove airborne iodine (in both the elemental and particulate forms) thus reducing the amount of activity available to leak from the containment.

The iodine removal constants of (λ_e and λ_p) are dependent on spray flow rate, droplet size, droplet fall time, and sprayed volume. The models from NUREG-0800, Section 6.5.2 (Reference 1) are used to calculate the removal constants.

Retention of iodine in solution depends on maintaining a sump solution pH of ≥ 7.0 in accordance with Regulatory Guide 1.183. |

ATTACHMENT A6.5

IODINE REMOVAL EFFECTIVENESS EVALUATIONOF CONTAINMENT SPRAY SYSTEMA6.5.1 CONTAINMENT SPRAY DROPLET MODELA6.5.1.1 Method of Calculation

In order to eliminate the need to scale-up factors from experimental results to full-sized reactor containments, the size dependent calculations in this model were programmed for discrete size parameters, i.e., the calculations are repeated for incremental height steps, and for 30 different drop-size groups to represent the effects of the drop-size distribution. No significant effect on results was observed by increasing the number of groups. The resulting model with discrete size dependent parameters has been programmed for a digital computer.

The CIRCUS computer code is used to analyze the containment spray to determine average droplet size and fall time. A detailed description of the mathematical models used in the code has been presented in many WCAP reports such as WCAP-8376, "Iodine Removal by Spray in the Joseph M. Farley Station Containment."

In the computer code, the sprayed volume of the containment is divided into layers of incremental height and area equal to the total sprayed area at any height z . The height-dependent calculations such as drop trajectories and the change in the drop size distribution due to coalescence, are performed for each height step, using the parameters calculated in the previous step as input for the next step.

A6.5.1.2 Drop-Size Distribution

The drop-size distribution used in the model is based on data obtained from measurements of the actual size distribution from the Sprayco 1713A nozzle for the design pressure drop of 40 psi. Discussion of this distribution and how it was obtained is presented in References 5 and 6.

A6.5.1.3 Condensation

As the spray solution enters the high temperature containment atmosphere, steam will condense on the spray drops. The amount of condensation is easily calculated by a mass balance of the drop:

$$m_h + m_c h_g = m' h_f \quad (\text{A6.5-1})$$

where:

m and m' = the mass of the drop before and after condensation, lb,

- m_c = the mass of condensate, lb,
 h = the initial enthalpy of the drop, Btu/lb, and
 h_g and h_f = saturation enthalpy of water vapor and liquid, Btu/lb.

The increase in each drop diameter in the distribution, therefore, is given by:

$$(d'/d)^3 = (v_f/v) ((h_g - h) / (h_{fg})) \quad (A6.5-2)$$

where:

- v_f = the specific volume of liquid at saturation, ft³/lb,
 v = the specific volume of the drop before condensation, ft³/lb,
 h_{fg} = the latent heat of evaporation, Btu/lb,
 d = the drop diameter, cm before condensation, and
 d' = the drop diameter, cm after condensation.

The drop-size distribution used in evaluating spray iodine removal effectiveness is a temporal distribution based on an average spatial distribution which is in turn determined by integrating the spatial distribution over the entire fall height, for discrete height steps including the effects of coalescence. In determining the spatial distribution for each height step, the spatial distribution from the previous step is used as input and no account is taken for the fact that the higher velocities of larger drops will result in these larger drops being further through their fall height at the end of the given height step. The only place where drop velocity enters into the calculation of spatial distribution is in evaluating the number of collisions due to differences in drop velocities within a given height step. The only changes in the spatial drop-size distribution throughout the spray fall height accounted for are those due to coalescence. Since the larger drops are available to coalesce for the same length of time as the smaller drops, the number of collisions between drops will be overpredicted. This will result in a relatively greater number of large drops, hence a lower available mass transfer surface area and larger terminal velocities. This last effect results in shorter drop residence times once the average spatial distribution is converted to a temporal distribution. These effects result in a conservative evaluation of spray iodine removal effectiveness.

An average temporal distribution can also be determined by converting the spatial distribution at each height step to a temporal distribution and then taking the average of these. When compared to this, the temporal distribution used in CIRCUS is more conservative in terms of both available mass transfer surface area and drop residence times. The distribution shown in Figure 4 of Reference 5, and Figure 2-3 of Reference 6, is based on over 30,000 data points.

Analysis of these drop-size measurements shows that the drop-size distribution from this nozzle may be represented by a continuous distribution function, which is used as the input to the computer code.

This increase in drop size due to condensation is expected to be complete in a few feet of fall for the majority of drop sizes in the distribution. More detailed calculations by Parsley (see Reference 2) show that even for the largest drops in the distribution, thermal equilibrium is reached in less than half of the available drop fall height. The change in the drop-size distribution due to condensation was conservatively modeled by a step increase to the equilibrium size immediately after the drops emerge from the nozzle.

A6.5.1.4 Drop Trajectories

A description of the actual drop trajectories is required to obtain accurate drop residence times and to obtain the trajectory angle required for the coalescence calculations described below. These trajectories are obtained by integrating the equations of motion for each drop size.

The equations of motion were integrated numerically with the drag coefficient being determined iteratively from Reynolds number and terminal velocity.

These calculations yield the following results.

A6.5.1.4.1 Spread and Nozzle Interference

Trajectory results for a range of drop sizes show that the horizontal velocities of the drops are quickly attenuated. For the smaller drop sizes ($<400\mu$), the trajectory essentially is a straight fall. Even for 1000μ drops, the horizontal velocity component diminishes to less than 10% of the total velocity in less than 10 feet. The effect of temperature and pressure on drop trajectories has also been calculated. The resulting spray envelope is of smaller diameter at higher temperatures and pressure.

For downward-directed spray nozzles, the initial vertical velocity is higher than the terminal velocity, resulting in a slightly shorter residence time.

Correction factors are calculated for each drop size in the spectrum, so that the drop fall-times used for the iodine removal calculations are the actual drop residence times.

A measure of conservatism is added to the drop residence calculations by the use of the drop diameters after condensation. Actually, the drop velocities would have been attenuated to a fraction of the initial nozzle velocity by the time condensation is complete.

A6.5.1.5 Drop Coalescence

This effect will tend to decrease the overall surface-to-volume ratio of the spray, thereby affecting the fission product removal capability of the system. Concern has been centered particularly on the effect of coalescence on scale-up factors applied to data obtained from small-scale experiments. The effects of this phenomenon are accounted for by a mathematical model which is independent of the containment size.

The mathematical model used to account for drop coalescence due to the effects of overlapping spray patterns and due to larger drops overtaking smaller ones shows the number of coalescences to be functions of the collision and coalescence efficiencies, as well as the trajectory angle, drop velocities, drop size, and drop density.

The coalescence efficiency is the probability that a collision will result in the formation of a single larger drop.

The collision efficiency describes the probability that two drops on a geometric collision course, i.e., their centers of motion are separated by a distance less than the sum of the radii of the two drops, will actually collide.

The results calculated with this model show that the smaller drops with diameters near the mode of the distribution are affected most. This is expected, since these sizes have the highest density of drop population. Due to the considerably larger volumes of the larger diameter drops, however, the increase in the larger drop population is not very pronounced.

A6.5.1.6 Results

Using the plant parameters from Table A6.5-1 and taking into account the effects of condensation, drop trajectories, and drop coalescence, the average droplet size calculated to be 1240 microns and the average fall time is 12.44 seconds.

A6.5.2 Elemental Iodine Spray Removal Coefficient

The NRC's Standard Review Plan (Reference 1) identifies a methodology for the determination of spray removal of elemental iodine independent of the use of spray additive. The removal rate constant is determined by:

$$\lambda_e = 6K_gTF / VD$$

Where λ_e = Removal rate constant due to spray removal, hr^{-1}
 K_g = Gas phase mass transfer coefficient, 9.84 ft/min
 T = Time of fall of the spray drops, min
 F = Volume flow rate of sprays, ft^3/hr
 V = Containment sprayed volume, ft^3
 D = Mass-mean diameter of the spray drops, ft

The upper limit specified for this model is 20 hr^{-1} .

Using the drop size and fall time from Subsection A6.5.1.6 and the plant parameters from Table A6.5-1, the elemental iodine removal coefficient is calculated to be greater than 20 hr^{-1} . Since Reference 1 specifies an upper limit of 20 hr^{-1} , this value is to be used in the loss-of-coolant accident (LOCA) dose analysis.

Removal of elemental iodine from the containment atmosphere is assumed to be terminated when the spray injection phase is terminated or, per Reference 1, when the airborne inventory drops to 0.5 percent of the total elemental iodine released to the containment (this is a DF of 200).

A6.5.3 Particulate Iodine Removal Coefficient

The particulate spray removal is determined using the model described in Reference 1:

$$\lambda_p = 3hFE / 2VD$$

Where λ_p = Removal rate constant due to spray removal, hr^{-1}
 h = Drop Fall Height, ft
 F = Spray Flow Rate, ft^3/hr
 V = Volume Sprayed, ft^3
 E = Single Drop Collection Efficiency
 D = Average Spray Drop Diameter

The E/D term depends upon the particle size distribution and spray drop size. From Reference 1, it is conservative to use 10 m^{-1} for E/D until the point is reached when the inventory in the atmosphere is reduced to 2% of its original (DF of 50) at which time the value for E/D is reduced by a factor of ten. The other parameters are taken from Table A6.5-1. Using these inputs, the value for λ_p is 6 hr^{-1} . When a DG of 50 is reached, the removal coefficient is reduced to 0.6 hr^{-1} .

A6.5.4 Spray Performance Evaluation

A6.5.4.1 Injection Phase Operation

The spray iodine removal analysis is based on the assumption that:

- a. Only one-out-of-two spray pumps are operating.

- b. The emergency core cooling system (ECCS) is operating at its maximum capacity.

The performance of the spray system was conservatively evaluated at the peak containment temperature and pressure following a postulated LOCA.

The spray flowrate of 2950 gpm per pump was used in the calculation of the spray removal coefficients.

Since this peak pressure condition is expected to exist, at most, for a few minutes, and since both mass transfer parameters and spray flowrate improve with decreasing pressure, an appreciable margin is added to this evaluation by this assumption.

A6.5.4.2 Recirculation Phase

Although elemental iodine removal by the sprays would be expected to continue during the spray recirculation phase, no credit is taken for removal of elemental iodine after the spray injection phase is terminated. Spray removal of particulate iodine would continue during the spray recirculation phase. Although the spray recirculation could continue indefinitely, it is assumed that sprays are terminated eight hours into the accident. |

A.6.5.4.3 Re-evolution of Iodine

Due to the addition of sodium hydroxide from the spray additive, the water in the containment sump is adjusted to a pH of greater than 7.0 and re-evolution of iodine need not be considered (Reference 1).

A6.5.5 References

1. NUREG-0800, NRC Standard Review Plan, Section 6.5.2
"Containment Spray as a Fission Product Cleanup System,"
Revision 2, December 1988.

B/B-UFSAR

2. L. F. Parsley, Jr., "Design Considerations of Reactor Containment Spray Systems - Part VI," ORNL-TM-2412, Part 6, 1969.
3. Deleted. |
4. Deleted. |
5. M. O. Sanford, "Sprayco Model 1713A Nozzle Spray Drop-Size Distribution," WCAP 8258, Revision 1, May 1975.
6. E. V. Somers and M. O. Sanford, "Iodine Removal by Spray in the Joseph M. Farley Station Containment," WCAP 8376, July 1974.

TABLE A6.5-1

INPUT PARAMETERS FOR SPRAY IODINE REMOVAL ANALYSIS

Containment temperature	260 °F*
Total containment free volume	$2.85 \times 10^6 \text{ ft}^3$
Fraction of containment volume sprayed	0.825
Spray fall height	141 ft
Net spray flowrate per pump	2950 gpm
Number of spray pumps operation	1 of 2

*The effect of higher peak LOCA containment temperatures has been evaluated up to 300°F and has been determined to be negligible (Reference Westinghouse letter MSE-TPM-059, dated September 1, 1995).

6.6 INSERVICE INSPECTION OF CLASS 2 AND 3 COMPONENTS

This section describes the inservice inspection program for Class 2 and 3 components.

6.6.1 Components Subject to Examination

Class 2 and 3 components are examined and tested in accordance with the requirements of ASME Section XI, Subsections IWC and IWD, respectively. The applicable Edition and Addenda of Section XI are specified in 10 CFR 50.55a and the Station ISI Program Plan. In cases where the Section XI requirements are determined to be impractical, a relief request is developed to detail why the examination(s) are impractical and also include proposed alternative examination(s). Relief requests are included in the station ISI program plan and submitted to the NRC for approval.

Byron and Braidwood have been approved to implement 10 CFR 50.69, "Risk-informed categorization and treatment of structures, systems, and components for nuclear power plants." This regulation provides an alternative approach for establishing requirements for treatment of structures, systems, and components (SSCs) using a risk-informed method of categorizing SSCs according to their safety significance. Specifically, for SSCs categorized as low safety significant, alternate treatment requirements may be implemented rather than treatments chosen by the ISI program. Refer to Section 3.2.3 for further information.

6.6.2 Accessibility

The design arrangements of Class 2 and 3 system components provides, to the extent possible, adequate clearances to conduct code required examinations. When specific exceptions to the above are identified, alternate examinations are described and justified in the inservice inspection program.

6.6.3 Examination Techniques and Procedures

The examination techniques and procedures described in Section XI of the code are used to the extent possible. When specific exceptions to the above are identified, alternate techniques and procedures will be described and justified in the inservice inspection program.

6.6.4 Inspection Intervals and Scheduling

An inspection interval, as defined in ASME Section XI Subarticle IWA-2400, is a 10-year interval of service. The schedule for inspection of Class 2 components is in accordance with Subarticles IWA-2400 and IWC-2400. The schedule for inspection of Class 3 components is in accordance with Subarticles IWA-2400 and IWD-2400.

6.6.5 Examination and Testing Requirements

Inservice inspection of Class 2 and 3 components is in agreement with the specific examination and testing requirements detailed in ASME Section XI, Tables IWC-2500-1 and IWD-2500-1, respectively. When these requirements cannot be met, a relief request is developed to detail why the examination(s) or test(s) are impractical and also include proposed alternative examination(s). Relief requests are included in the Station ISI Program Plan and submitted to the NRC for approval.

6.6.6 Evaluation of Examination Results/Repair Procedures

Evaluation of the examination results for Class 2 and 3 components complies with the requirements of Articles IWC-3000 and IWD-3000, respectively. Repair procedures for Class 2 and 3 components comply with the requirements of Articles IWC-4000 and IWD-4000, respectively.

6.6.7 System Pressure Testing

System pressure testing of Class 2 and 3 components is performed in accordance with ASME Section XI, Articles IWC-5000 and IWD-5000, respectively.

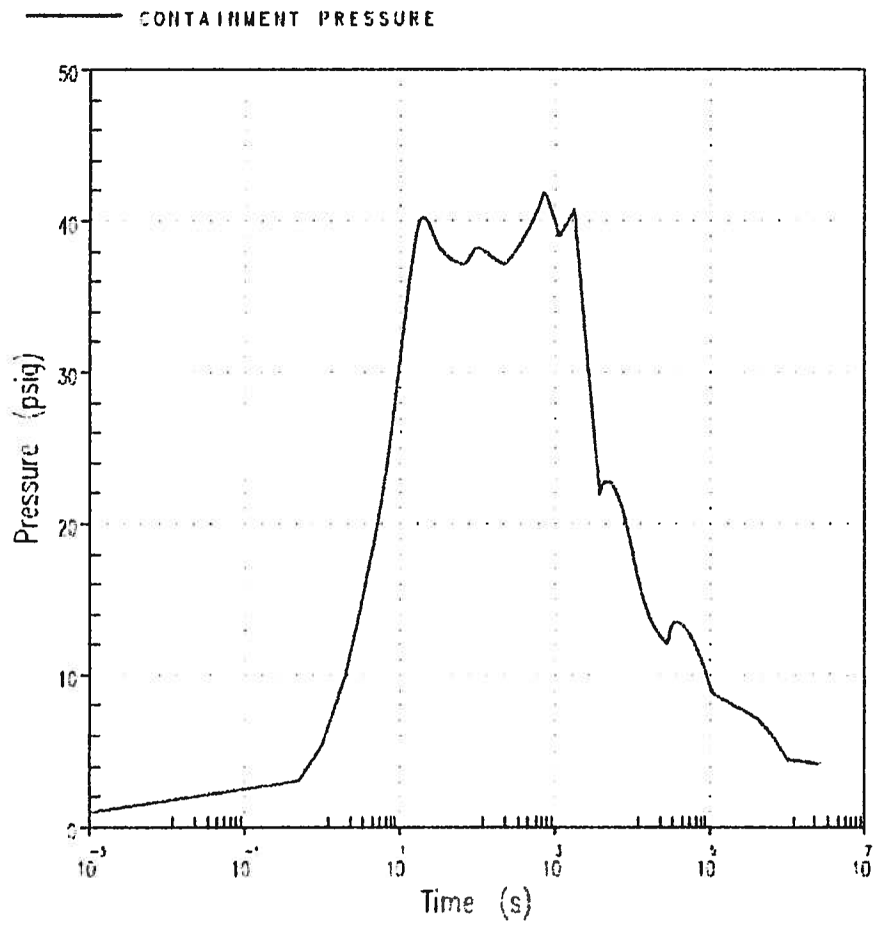

BYRON/BRAIDWOOD STATION
UPDATED FINAL SAFETY ANALYSIS REPORT

FIGURE 6.2-1
LOCA CONTAINMENT PRESSURE RESPONSE FOR
DOUBLE ENDED PUMP SUCTION BREAK
MINIMUM SI UNIT 1

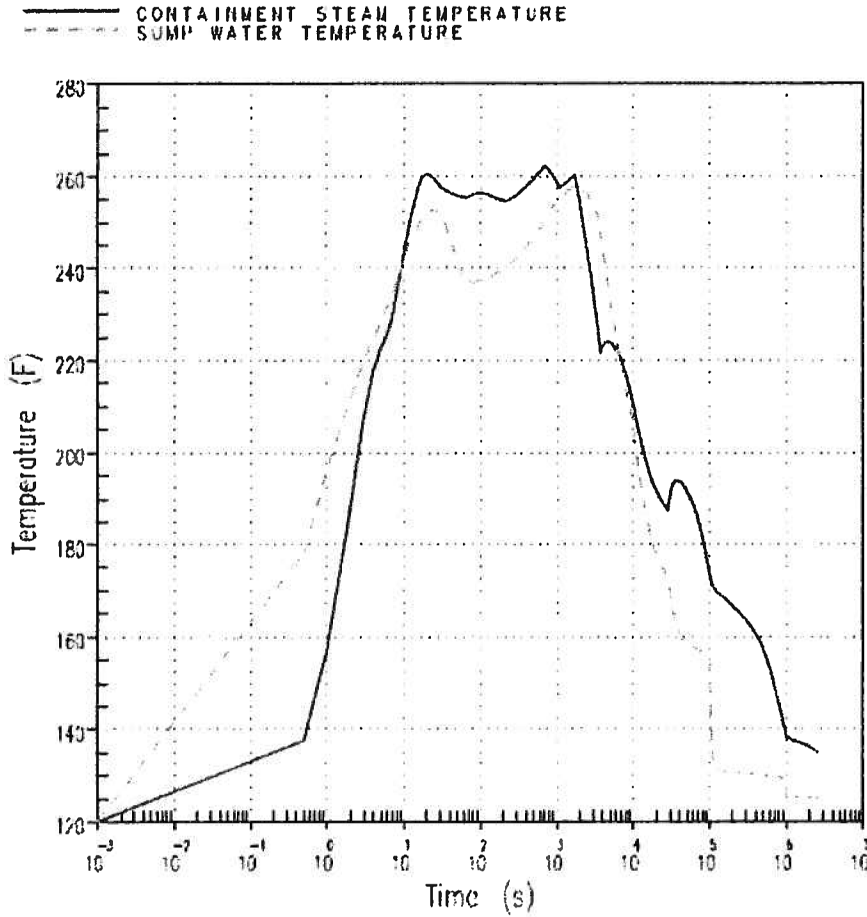

BYRON/BRAIDWOOD STATION
UPDATED FINAL SAFETY ANALYSIS REPORT

FIGURE 6.2-2
LOCA CONTAINMENT TEMPERATURE RESPONSE
FOR DOUBLE ENDED PUMP SUCTION BREAK
MINIMUM SI UNIT 1

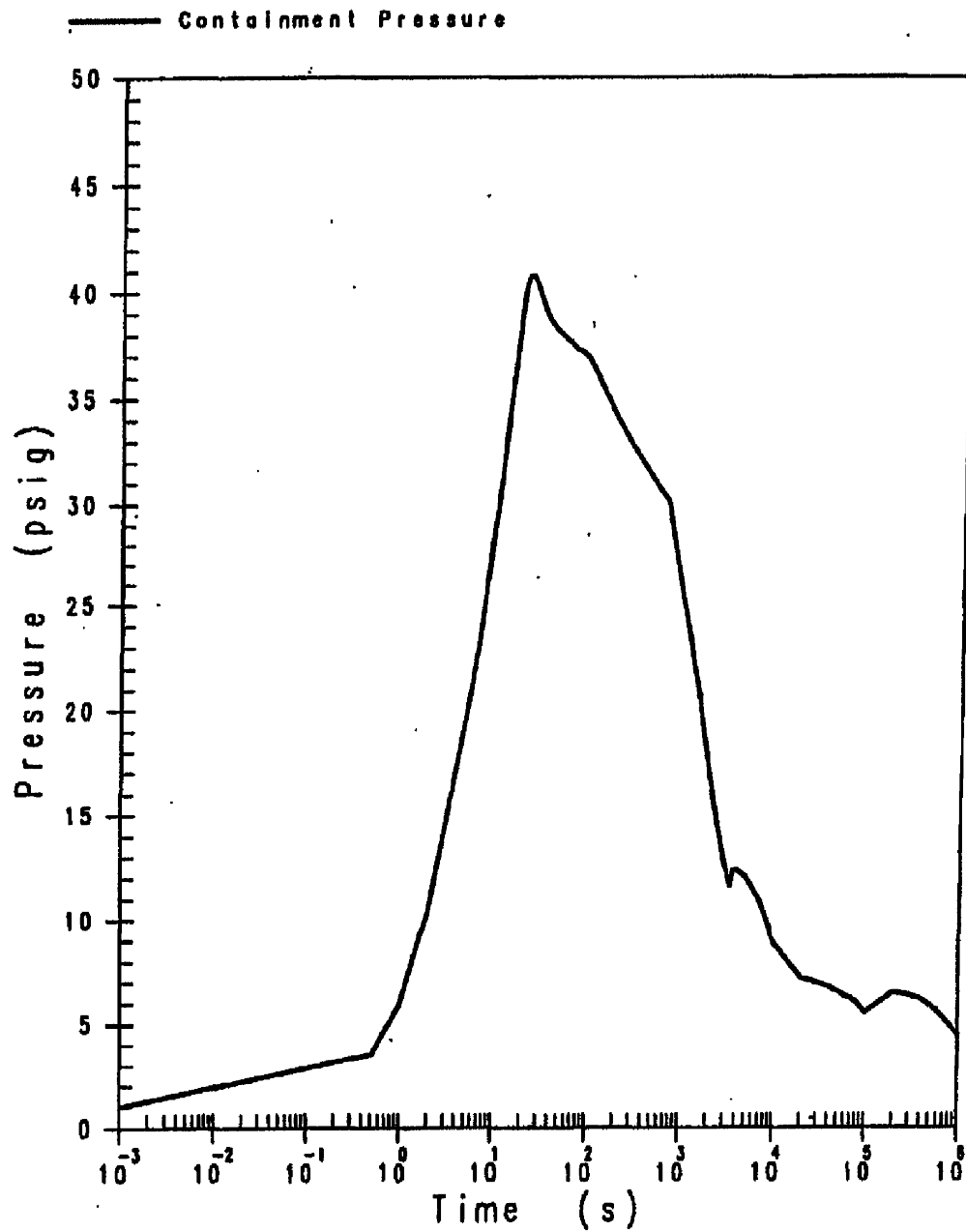

BYRON/BRAIDWOOD STATION
UPDATED FINAL SAFETY ANALYSIS REPORT

FIGURE 6.2-3
LOCA CONTAINMENT PRESSURE RESPONSE FOR
DOUBLE ENDED PUMP SUCTION BREAK
MAXIMUM SI UNIT 1

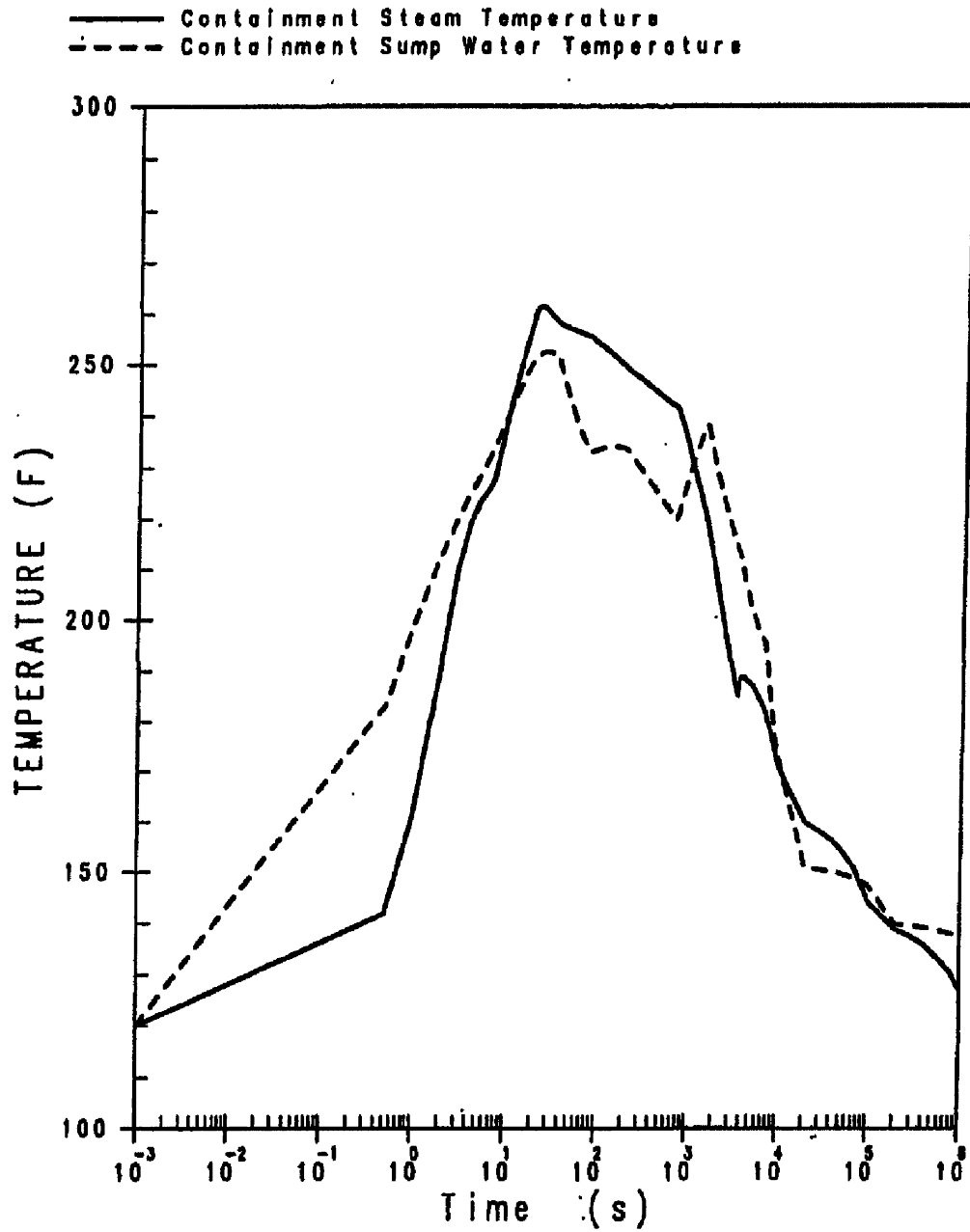

BYRON/BRAIDWOOD STATION
UPDATED FINAL SAFETY ANALYSIS REPORT

FIGURE 6.2-4

LOCA CONTAINMENT TEMPERATURE RESPONSE
FOR DOUBLE ENDED PUMP SUCTION BREAK
MAXIMUM SI UNIT 1

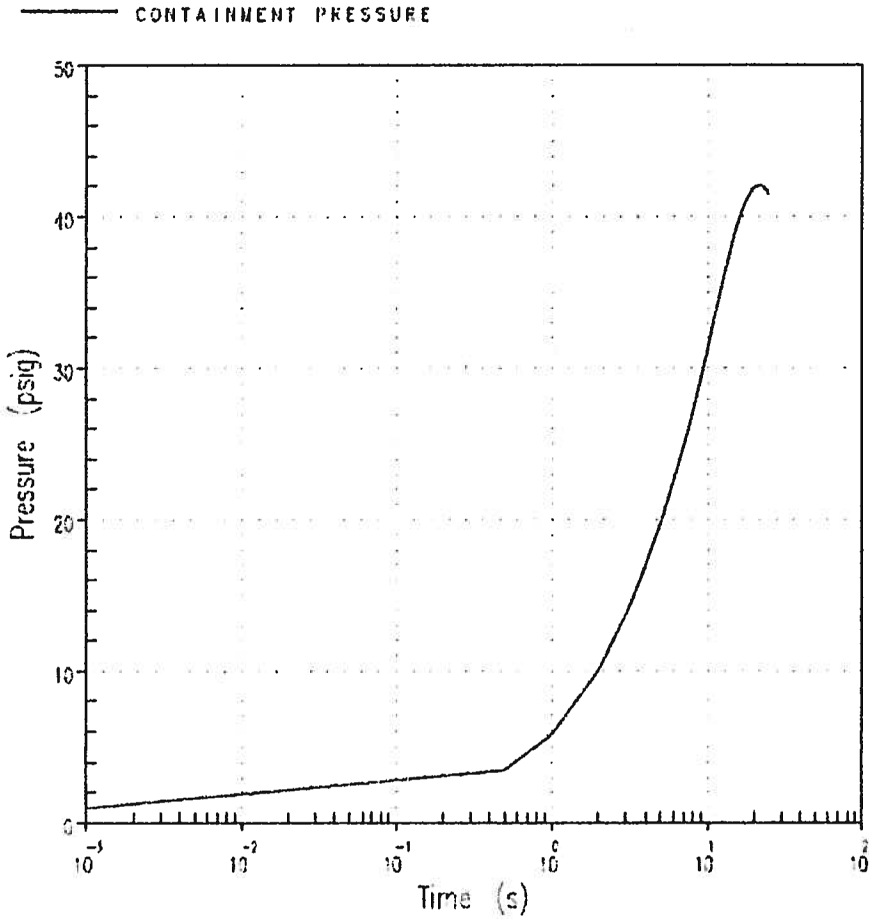

BYRON/BRAIDWOOD STATION
UPDATED FINAL SAFETY ANALYSIS REPORT

FIGURE 6.2-5
LOCA CONTAINMENT PRESSURE RESPONSE FOR
DOUBLE ENDED HOT LEG BREAK
UNIT 1

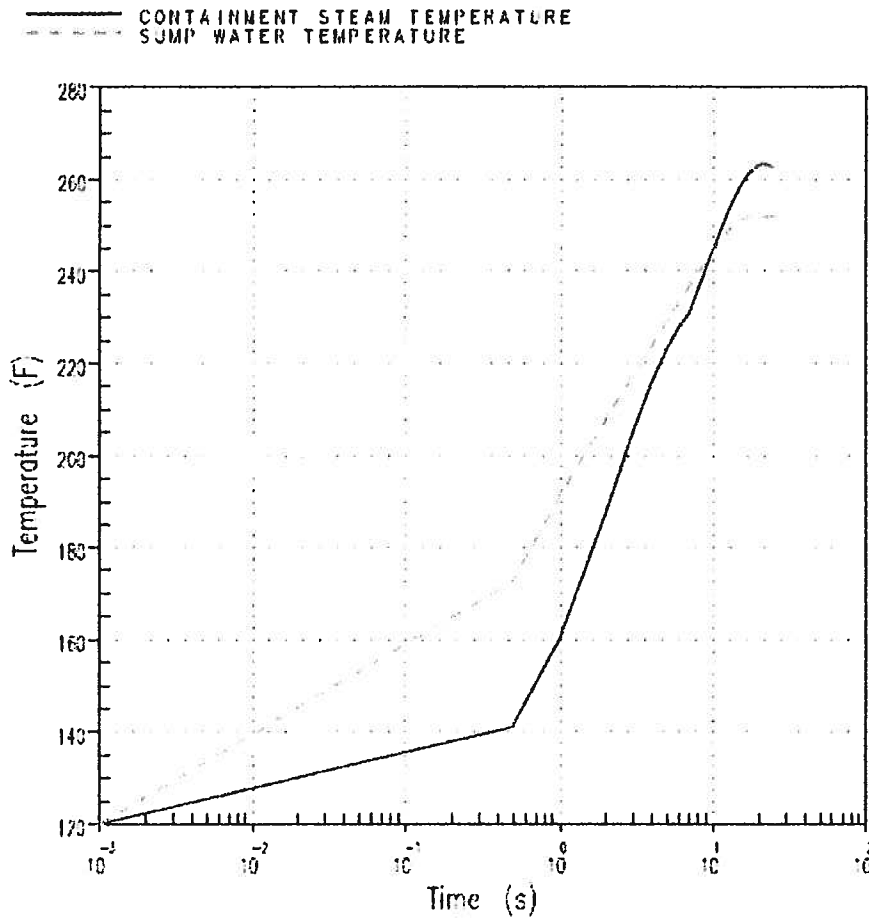

BYRON/BRAIDWOOD STATION
UPDATED FINAL SAFETY ANALYSIS REPORT

FIGURE 6.2-6
LOCA CONTAINMENT TEMPERATURE RESPONSE
FOR DOUBLE ENDED HOT LEG BREAK
UNIT 1

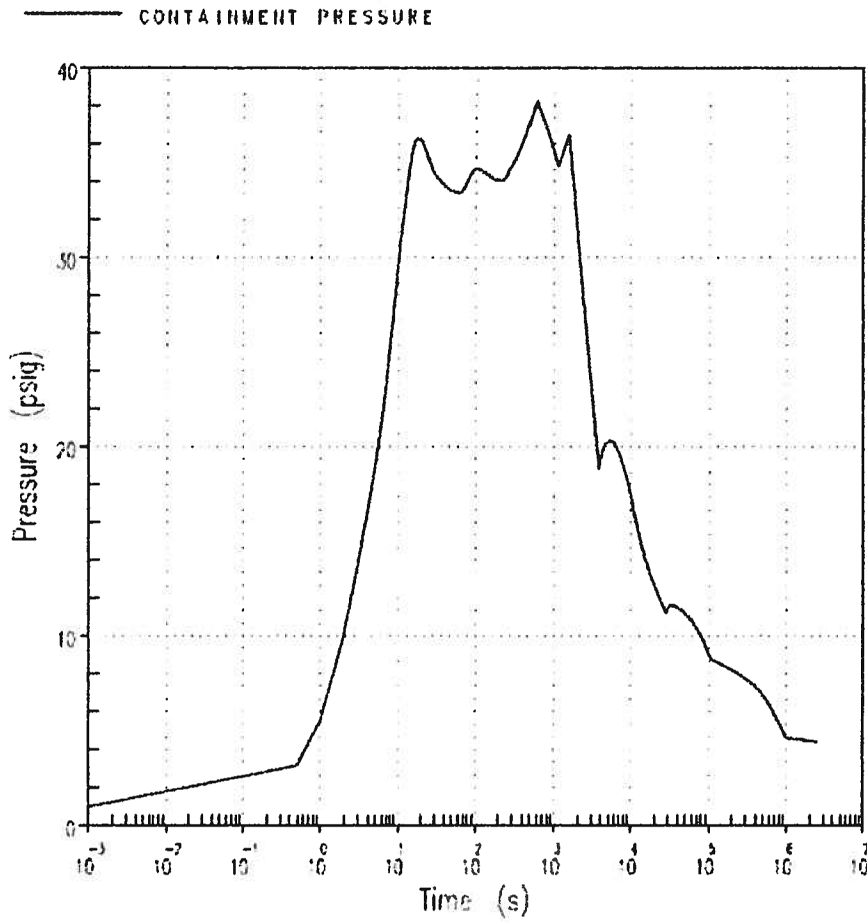

BYRON/BRAIDWOOD STATION
UPDATED FINAL SAFETY ANALYSIS REPORT

FIGURE 6.2-7
LOCA CONTAINMENT PRESSURE RESPONSE FOR
DOUBLE ENDED PUMP SUCTION BREAK
MINIMUM SI UNIT 2

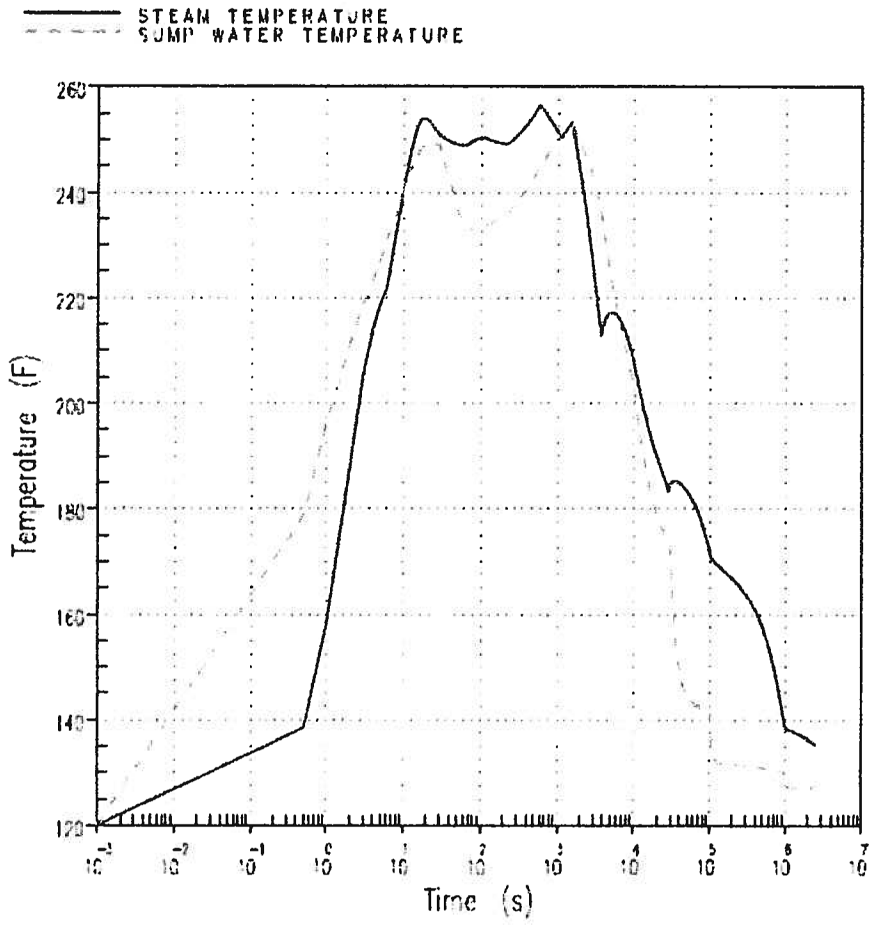

BYRON/BRAIDWOOD STATION
UPDATED FINAL SAFETY ANALYSIS REPORT

FIGURE 6.2-8
LOCA CONTAINMENT TEMPERATURE RESPONSE
FOR DOUBLE ENDED PUMP SUCTION BREAK
MINIMUM SI UNIT 2

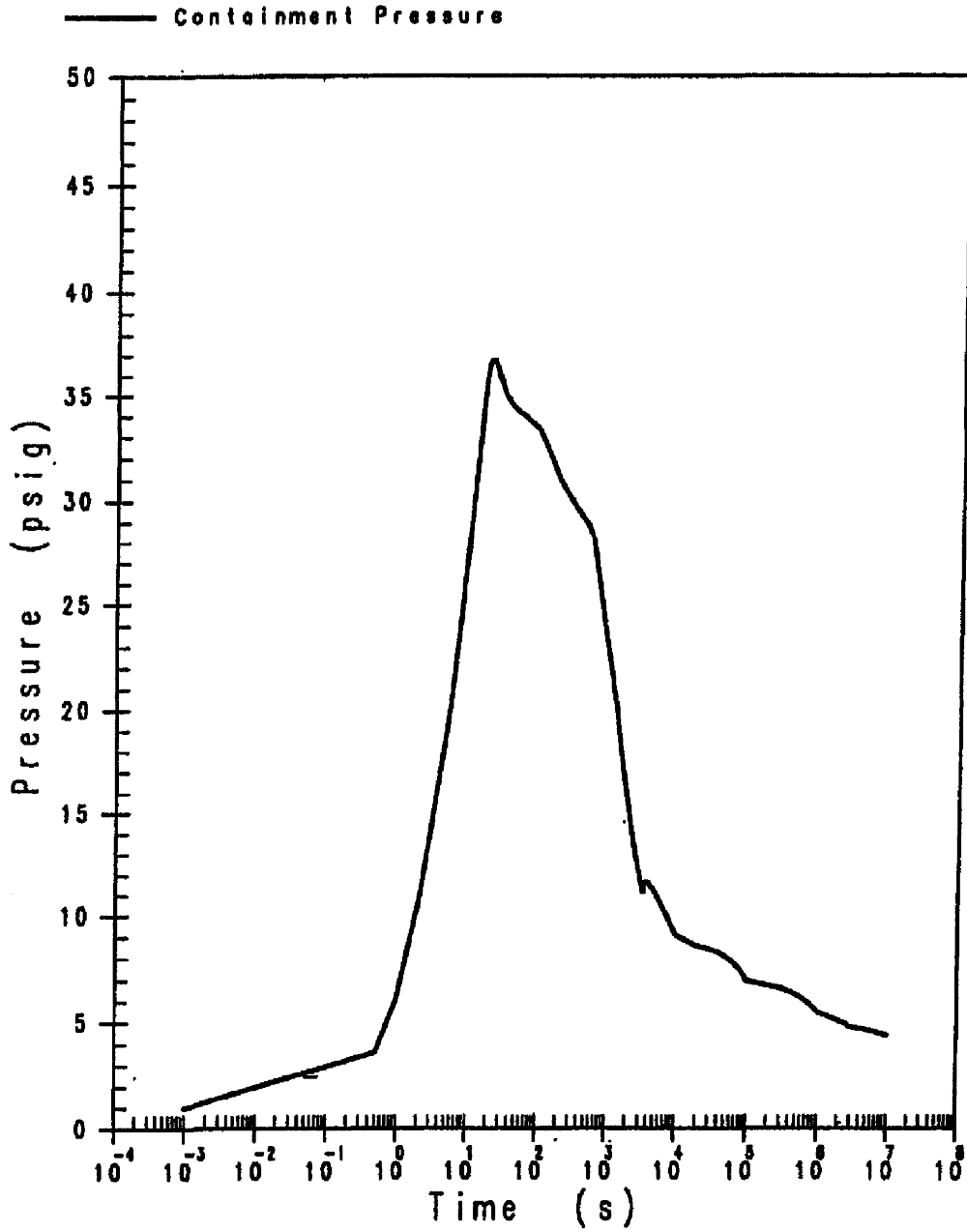

BYRON/BRAIDWOOD STATION
UPDATED FINAL SAFETY ANALYSIS REPORT

FIGURE 6.2-9
LOCA CONTAINMENT PRESSURE RESPONSE FOR
DOUBLE ENDED PUMP SUCTION BREAK
MAXIMUM SI UNIT 2

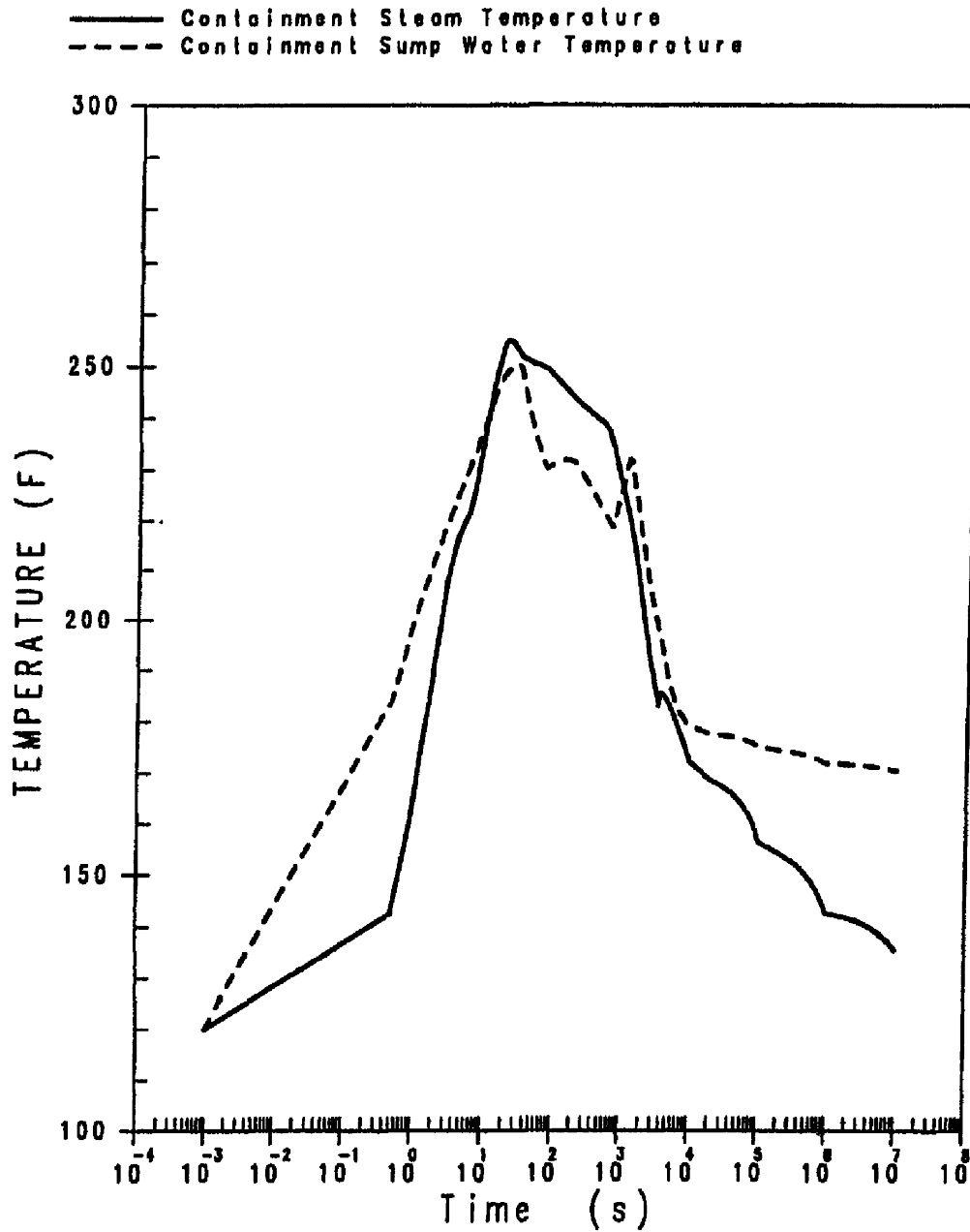

BYRON/BRAIDWOOD STATION
UPDATED FINAL SAFETY ANALYSIS REPORT

FIGURE 6.2-10
LOCA CONTAINMENT TEMPERATURE RESPONSE
FOR DOUBLE ENDED PUMP SUCTION BREAK
MAXIMUM SI UNIT 2

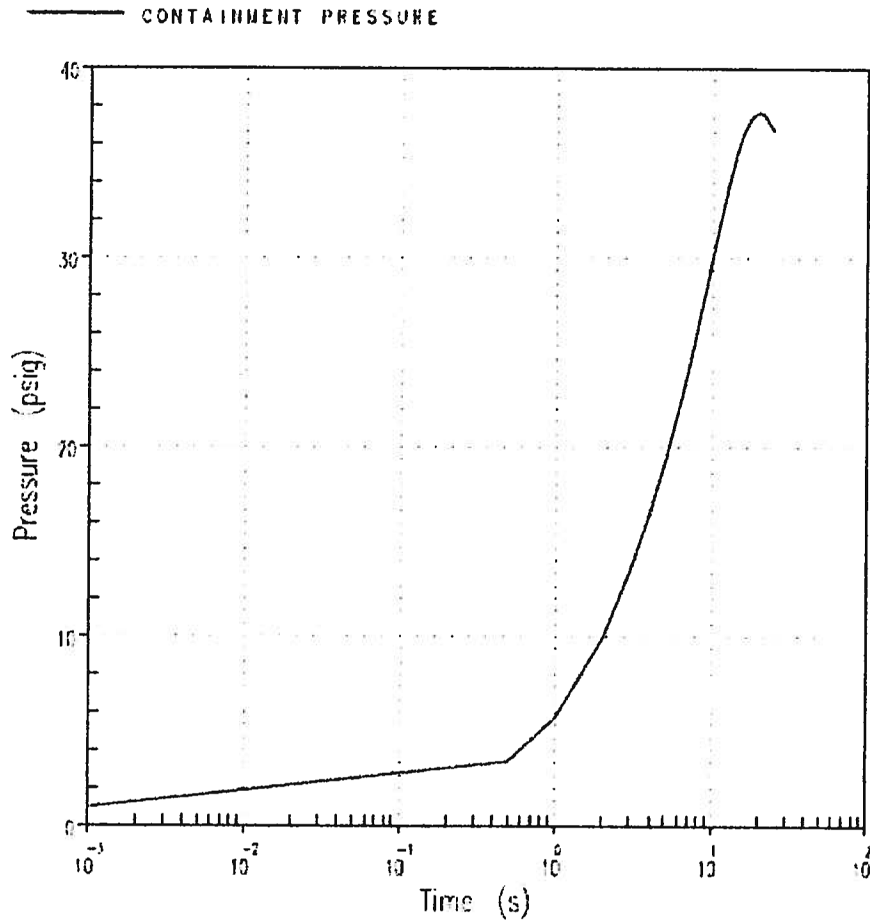

BYRON/BRAIDWOOD STATION
UPDATED FINAL SAFETY ANALYSIS REPORT

FIGURE 6.2-11
LOCA CONTAINMENT PRESSURE RESPONSE FOR
DOUBLE ENDED HOT LEG BREAK
UNIT 2

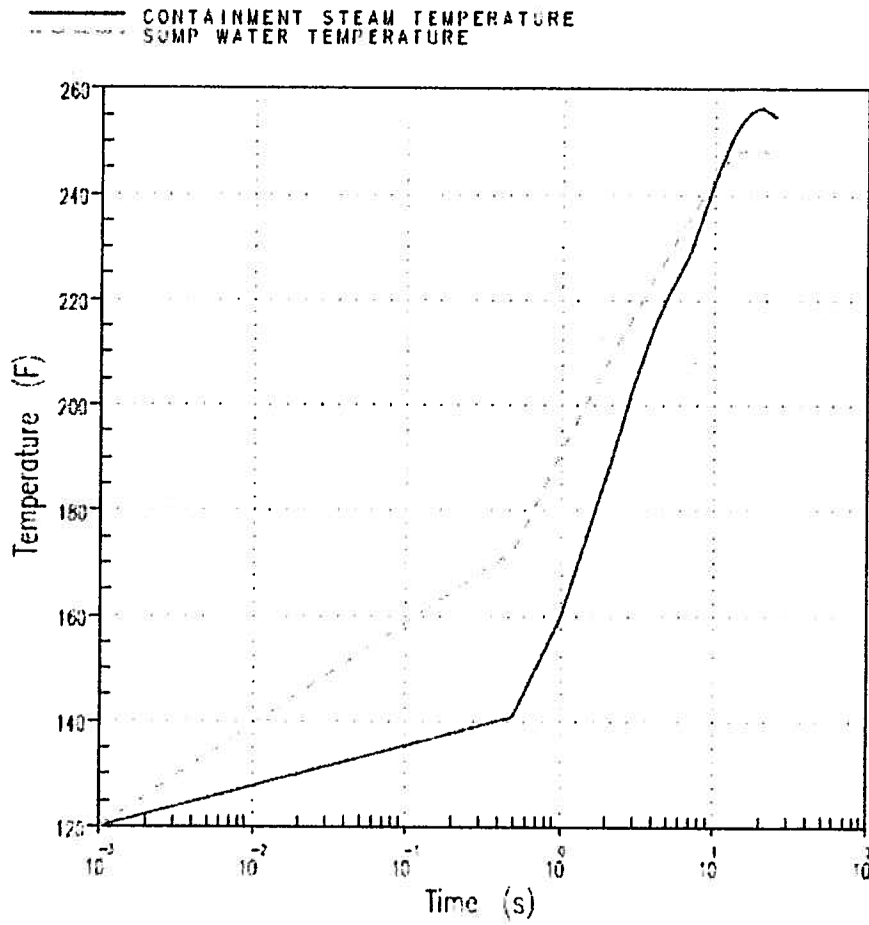

BYRON/BRAIDWOOD STATION
UPDATED FINAL SAFETY ANALYSIS REPORT

FIGURE 6.2-12
LOCA CONTAINMENT TEMPERATURE RESPONSE
FOR DOUBLE ENDED HOT LEG BREAK
UNIT 2

REVISION 7
DECEMBER 1998

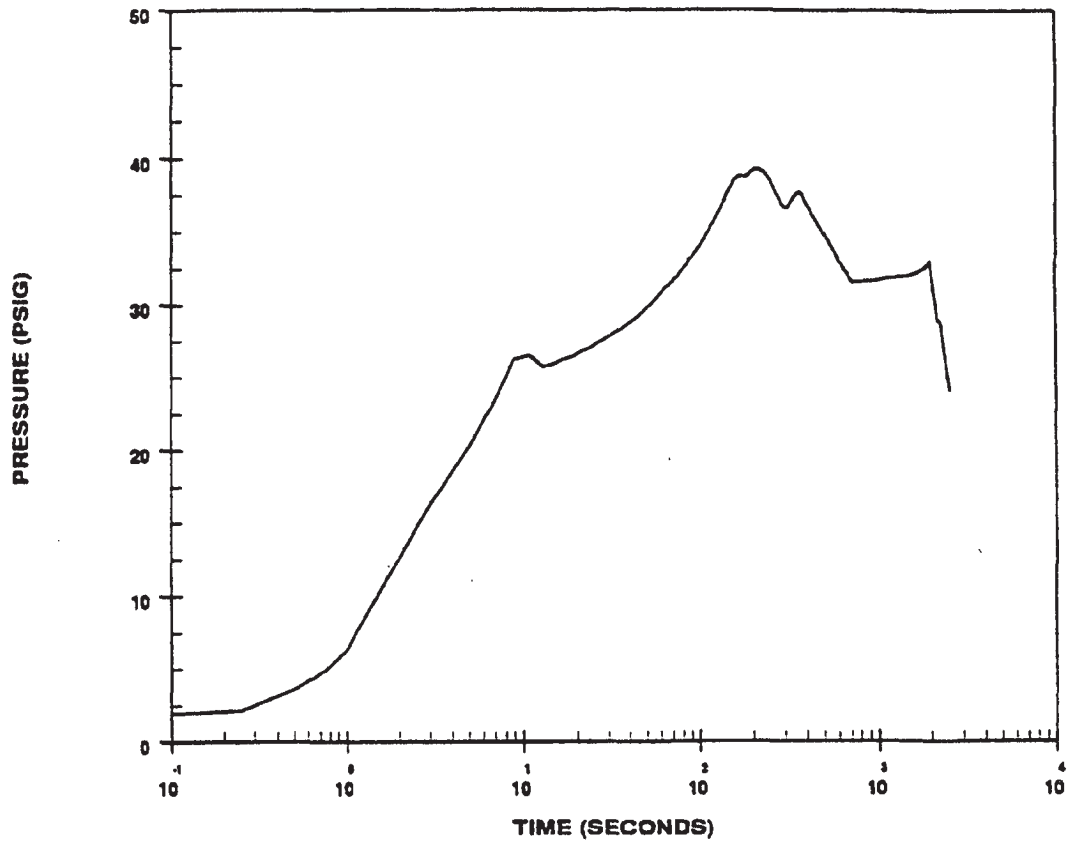

BYRON/BRAIDWOOD STATIONS
UPDATED FINAL SAFETY ANALYSIS REPORT

FIGURE 6.2-13
MSLB CONTAINMENT PRESSURE RESPONSE
COMPOSITE CURVE
UNIT 1

Containment Pressure for SLB Unit 1 Most Limiting SLB Case

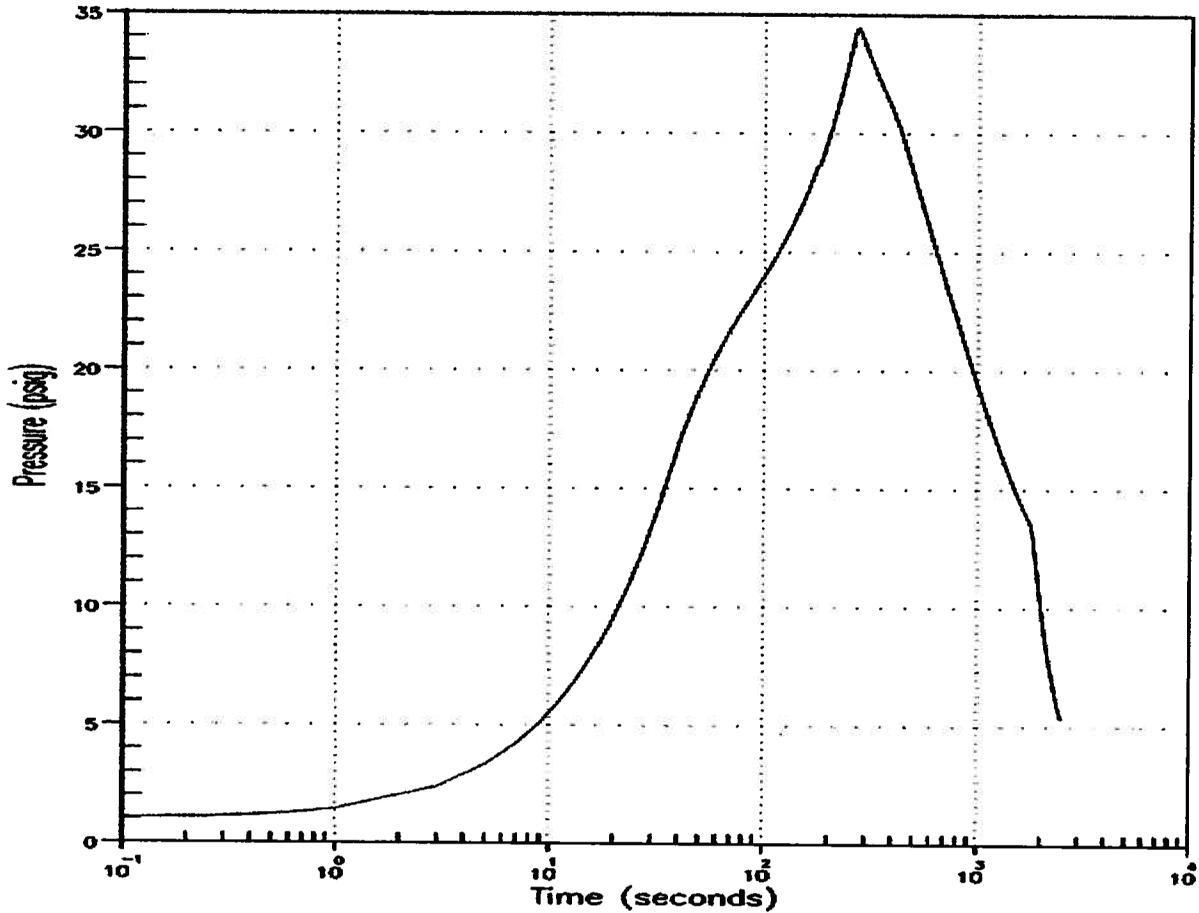

BYRON/BRAIDWOOD STATION
UPDATED FINAL SAFETY ANALYSIS REPORT

FIGURE 6.2-13a
MSLB CONTAINMENT PRESSURE RESPONSE FOR
0.83 FT² SPLIT BREAK AT 30% POWER AND MAIN
STEAM ISOLATION VALVE FAILURE - UNIT 1

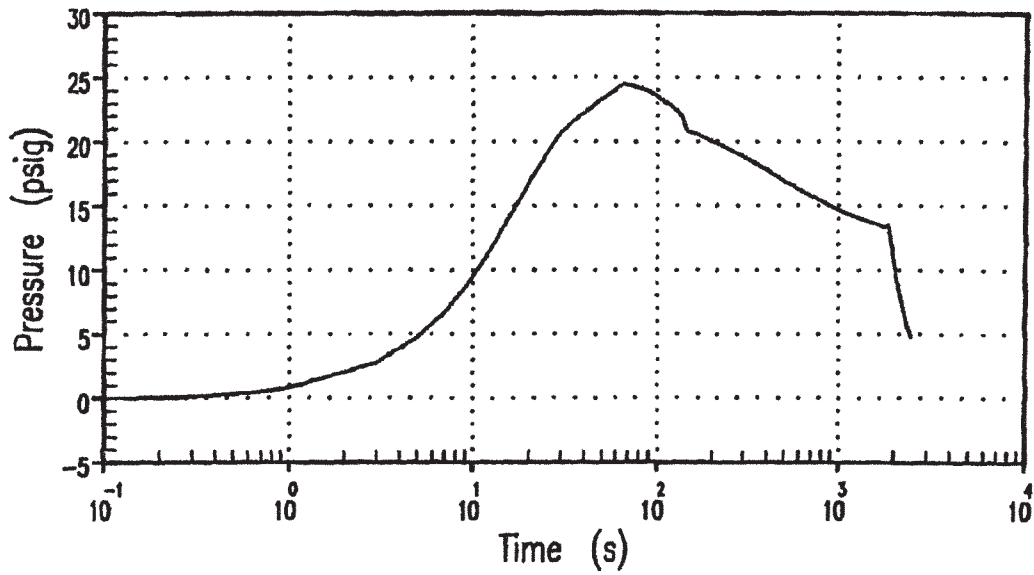

BYRON/BRAIDWOOD STATION
UPDATED FINAL SAFETY ANALYSIS REPORT

FIGURE 6.2-13b
MSLB CONTAINMENT PRESSURE RESPONSE FOR
1.0 FT² DER AT 102% POWER WITH LOOP AND
MAIN STEAM ISOLATION VALVE FAILURE - UNIT 1

REVISION 8
DECEMBER 2000

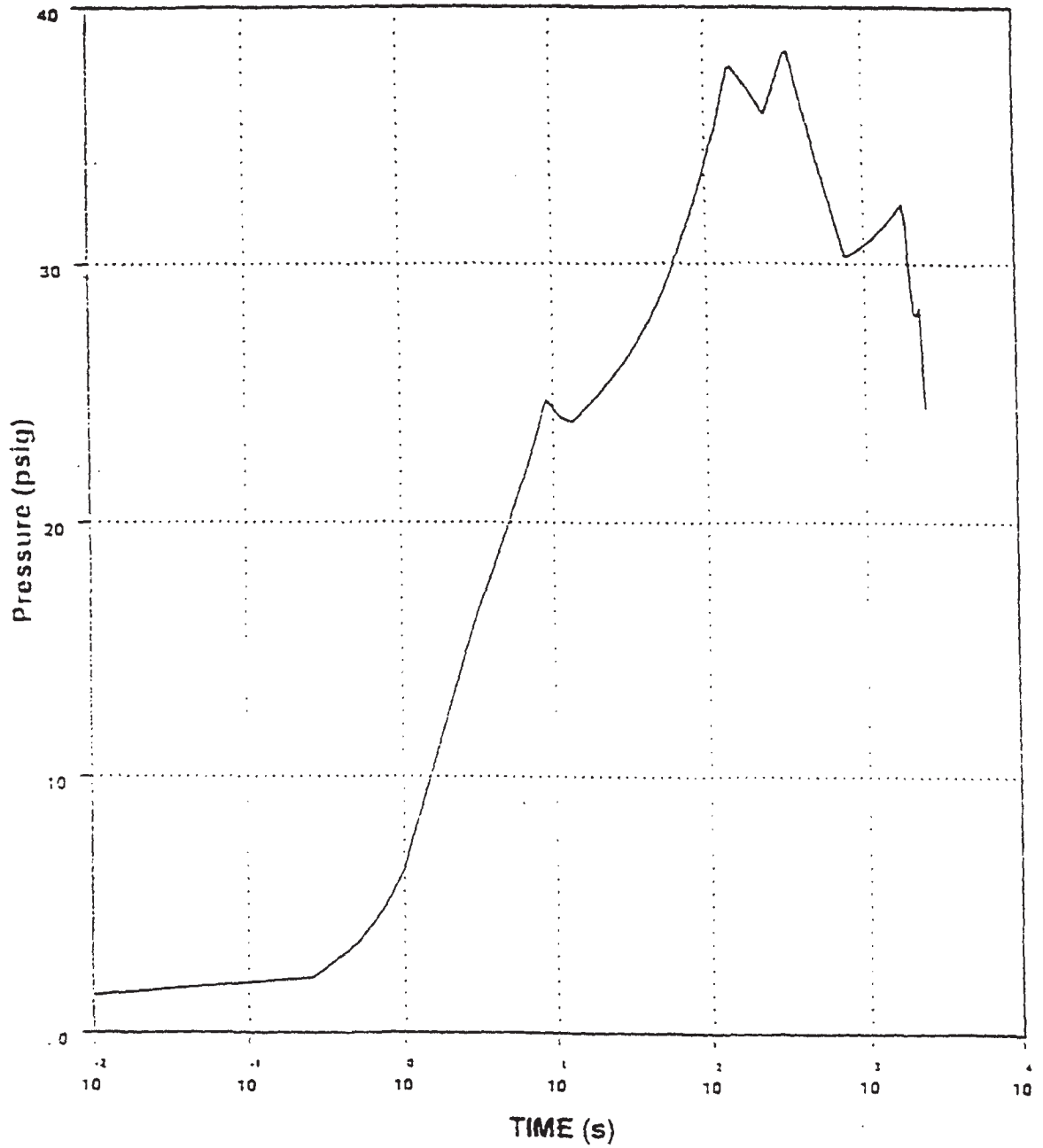

BYRON/BRAIDWOOD STATIONS
UPDATED FINAL SAFETY ANALYSIS REPORT
FIGURE 6.2 - 13c
MSLB CONTAINMENT PRESSURE RESPONSE
COMPOSITE CURVE, UNIT 2

Containment Pressure for SLB Unit 2 Most Limiting SLB Case

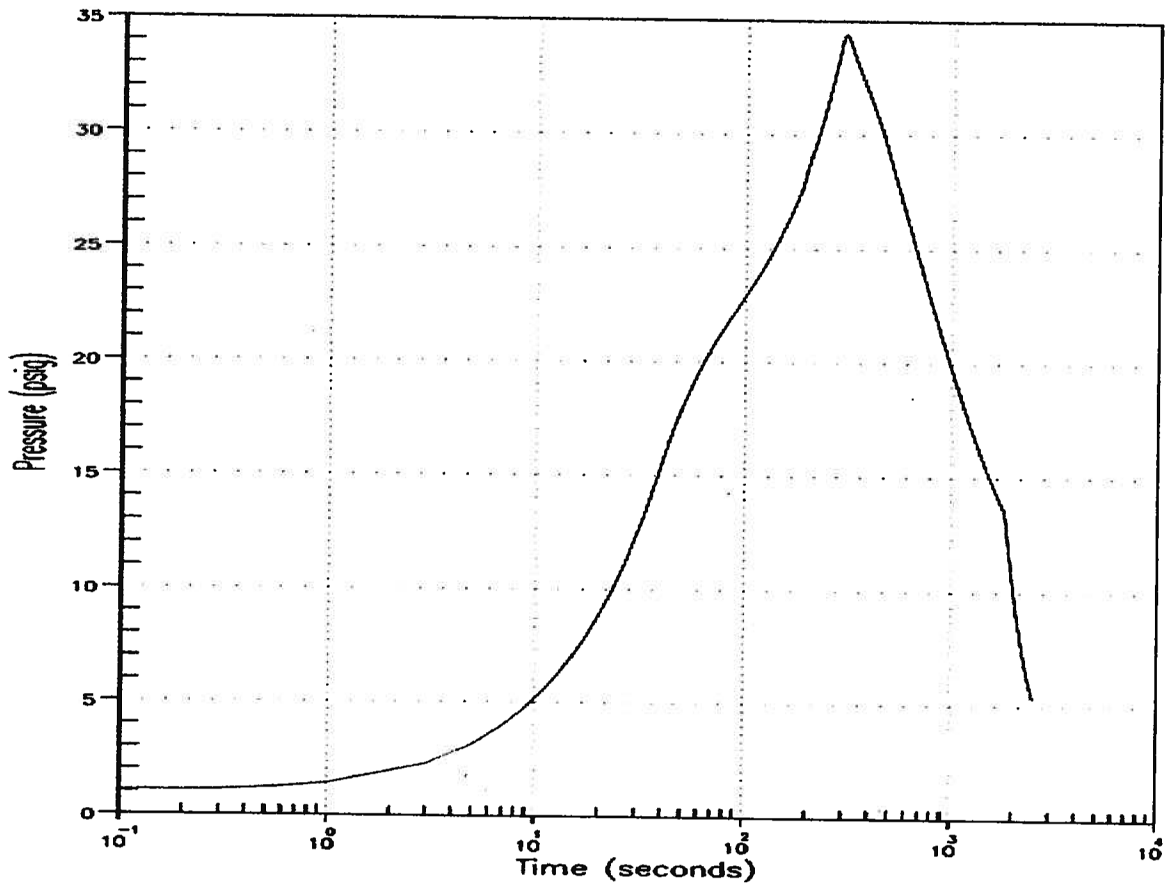

BYRON/BRAIDWOOD STATION
UPDATED FINAL SAFETY ANALYSIS REPORT

FIGURE 6.2-13d

MSLB CONTAINMENT PRESSURE RESPONSE FOR
0.83 FT² SPLIT BREAK AT 30% POWER AND
MAIN STEAM ISOLATION VALVE FAILURE - UNIT 2

Figure 6.2-13e has been deleted intentionally.

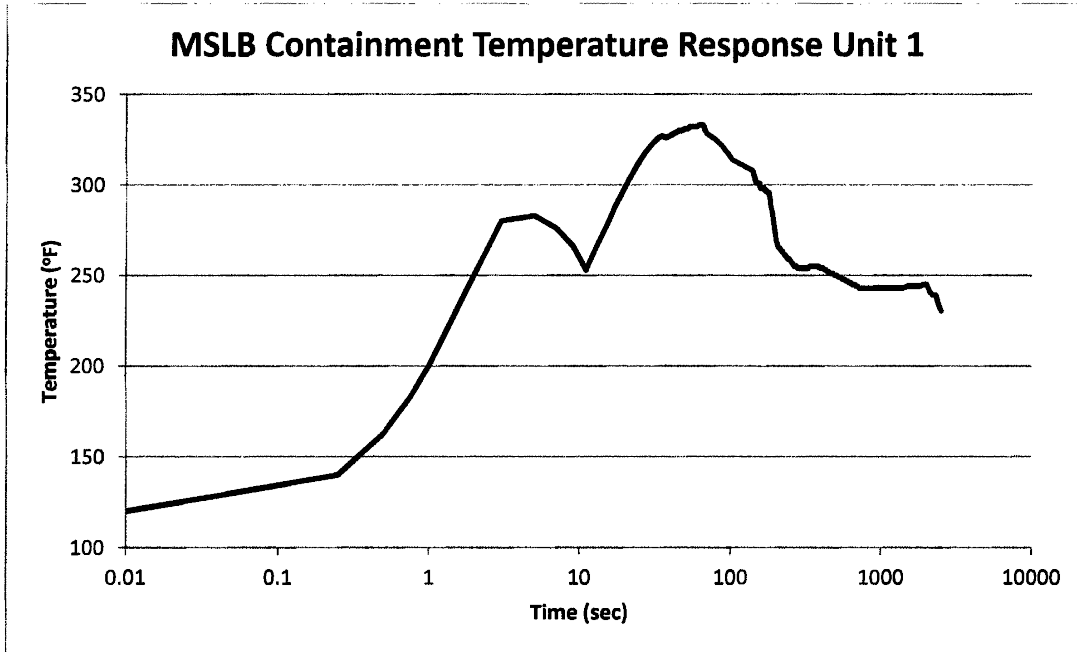

BYRON/BRAIDWOOD STATION
UPDATED FINAL SAFETY ANALYSIS REPORT

FIGURE 6.2-14
MSLB CONTAINMENT TEMPERATURE RESPONSE
COMPOSITE CURVE UNIT 1

REVISION 17
DECEMBER 2018

Containment Temperature for SLB Unit 1 Most Limiting SLB Case

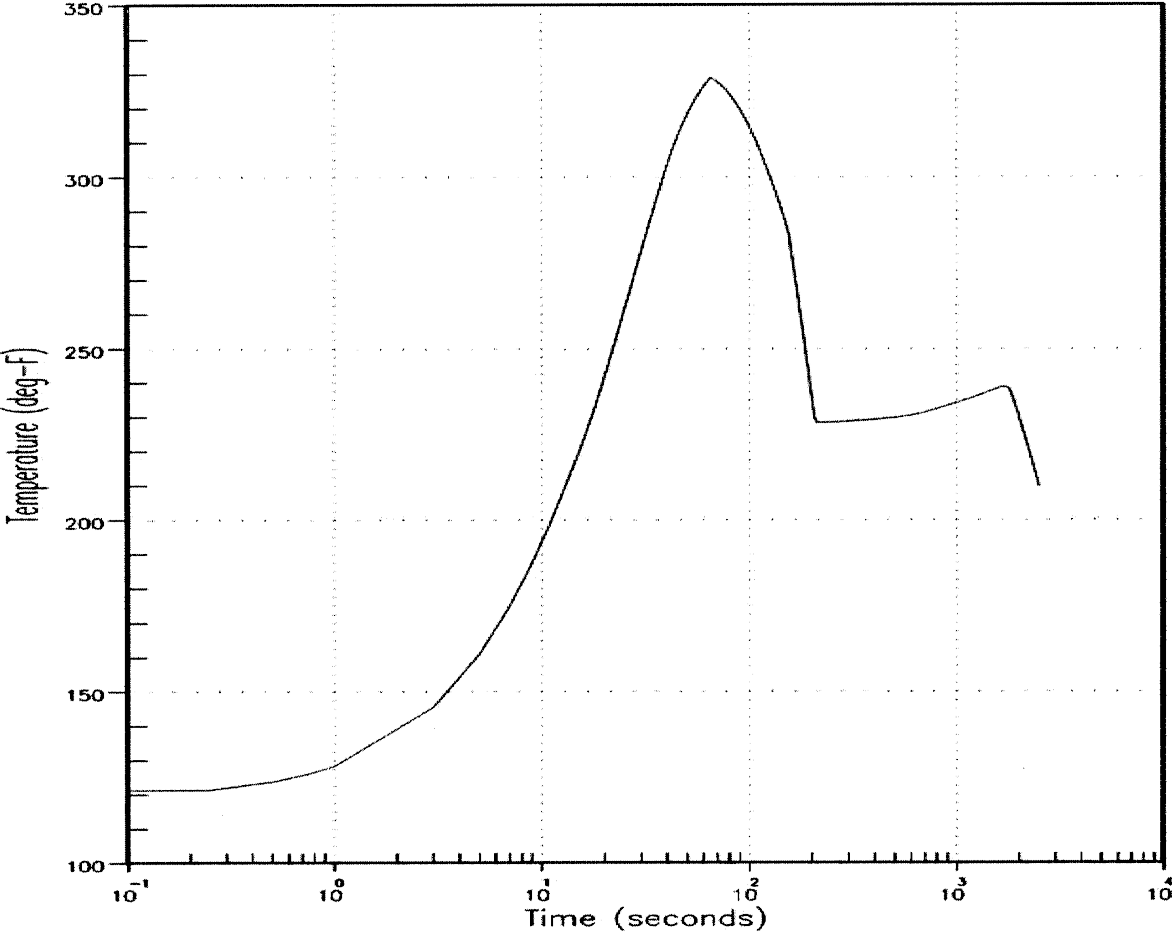

BYRON/BRAIDWOOD STATION
UPDATED FINAL SAFETY ANALYSIS REPORT

FIGURE 6.2-14a
MSLB CONTAINMENT TEMPERATURE RESPONSE FOR
0.81 FT² SPLIT BREAK AT 100% POWER WITH LOOP
& MAIN STEAM ISOLATION VALVE FAILURE UNIT 1

Figure 6.2-14b has been deleted intentionally.

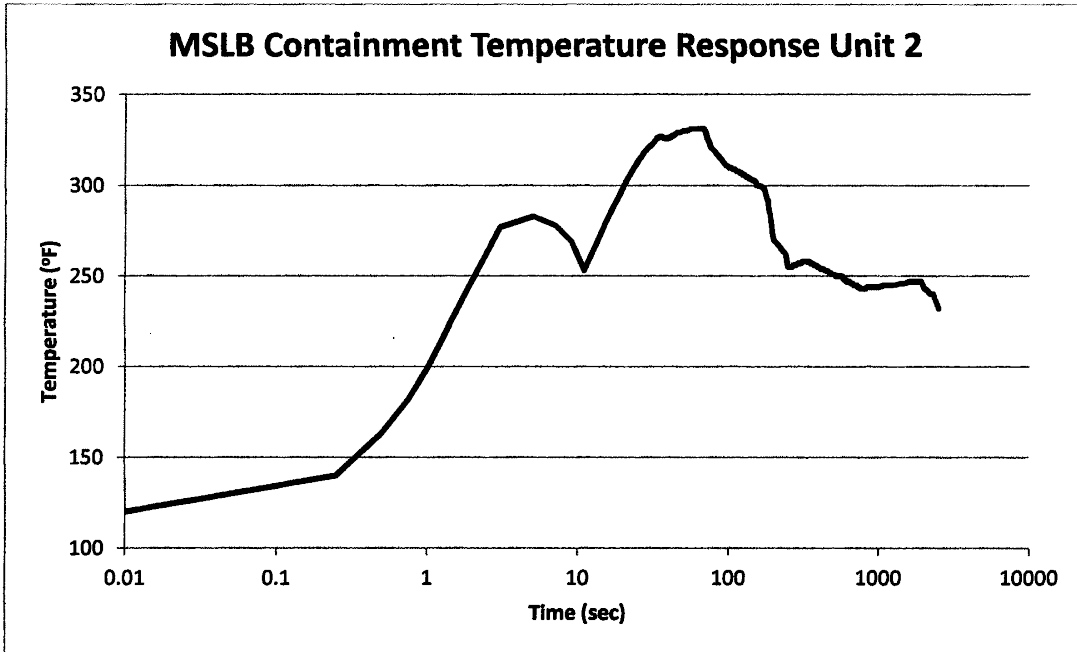

BYRON/BRAIDWOOD STATION
UPDATED FINAL SAFETY ANALYSIS REPORT

FIGURE 6.2-14c
MSLB CONTAINMENT TEMPERATURE RESPONSE
COMPOSITE CURVE UNIT 2

Figure 6.2-14d has been deleted intentionally.

Figure 6.2-14e has been deleted intentionally.

Containment Temperature for SLB Unit 2 Most Limiting SLB Case

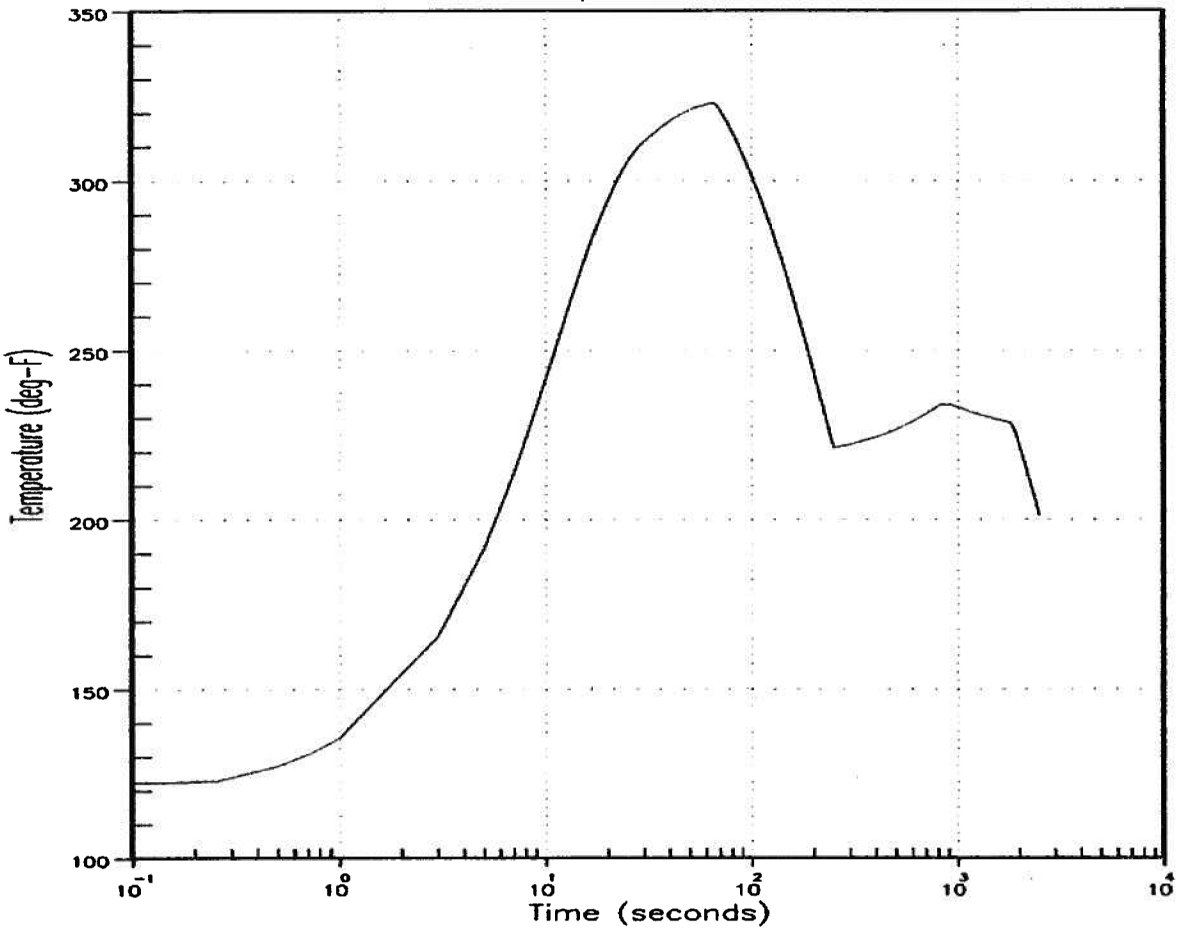

BYRON/BRAIDWOOD STATION
UPDATED FINAL SAFETY ANALYSIS REPORT

FIGURE 6.2-15

MSLB CONTAINMENT TEMPERATURE RESPONSE
FOR 1.00 FT² DER AT 100% POWER WITH LOOP &
MAIN STEAM ISOLATION VALVE FAILURE UNIT 2

Figures 6.2-16 through 6.2-16c have been deleted intentionally.

Figures 6.2-17a through 6.2-17b have been deleted intentionally.

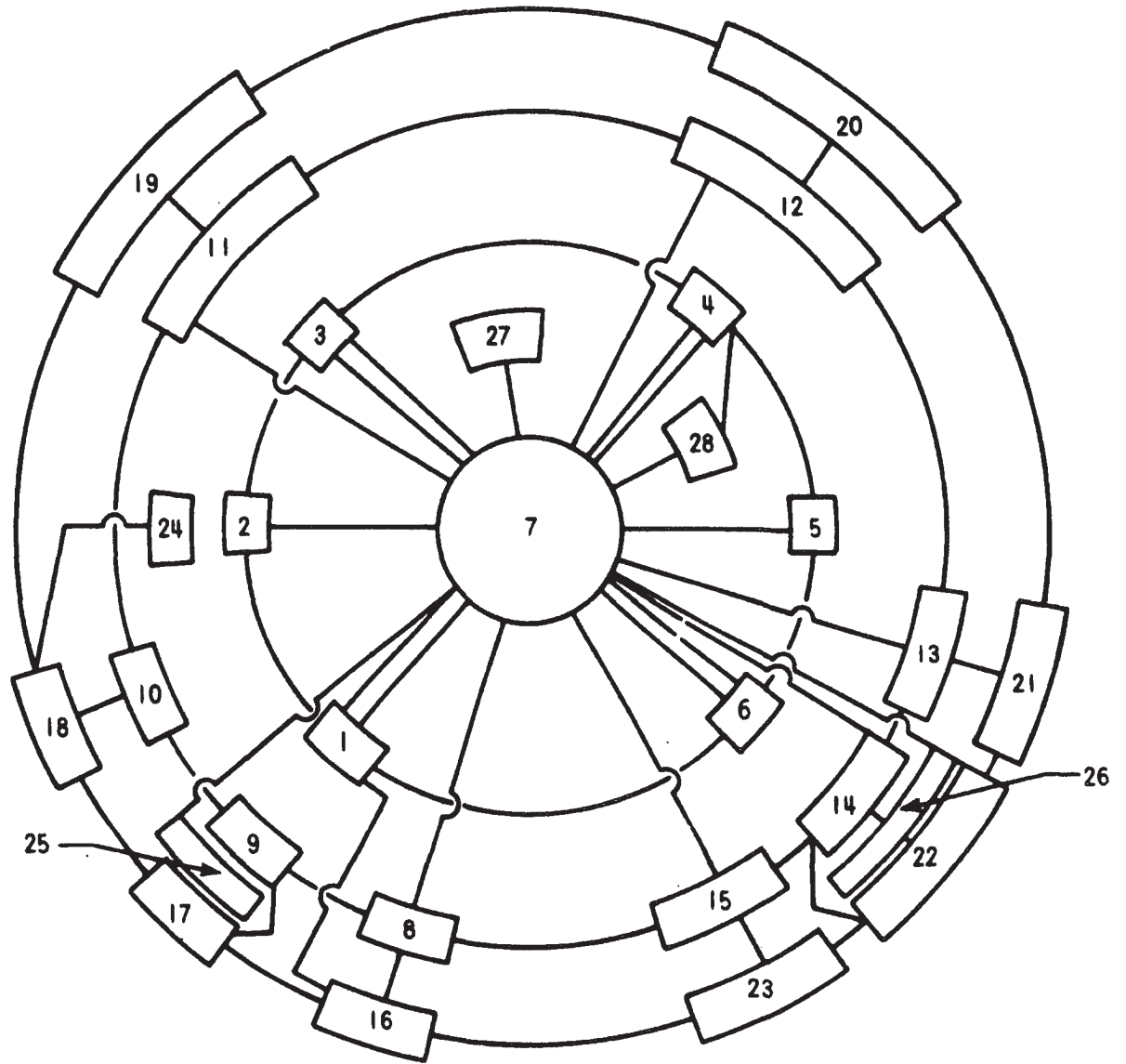

**BYRON/BRAIDWOOD STATIONS
UPDATED FINAL SAFETY ANALYSIS REPORT**

FIGURE 6.2-18

**CONTAINMENT SUBCOMPARTMENT
NODALIZATION DIAGRAM**

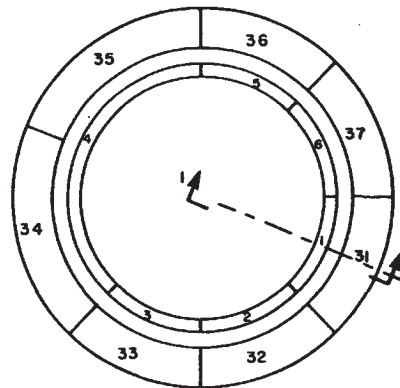

SECTION 2-2

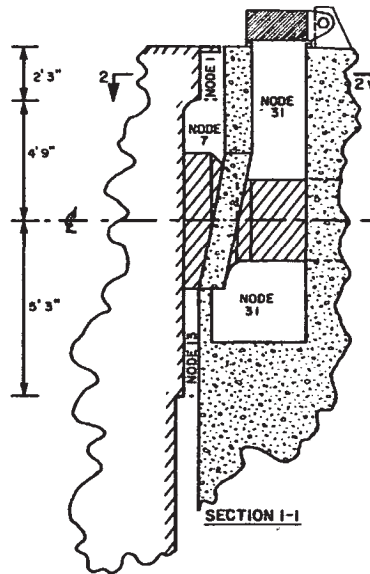

SECTION 1-1

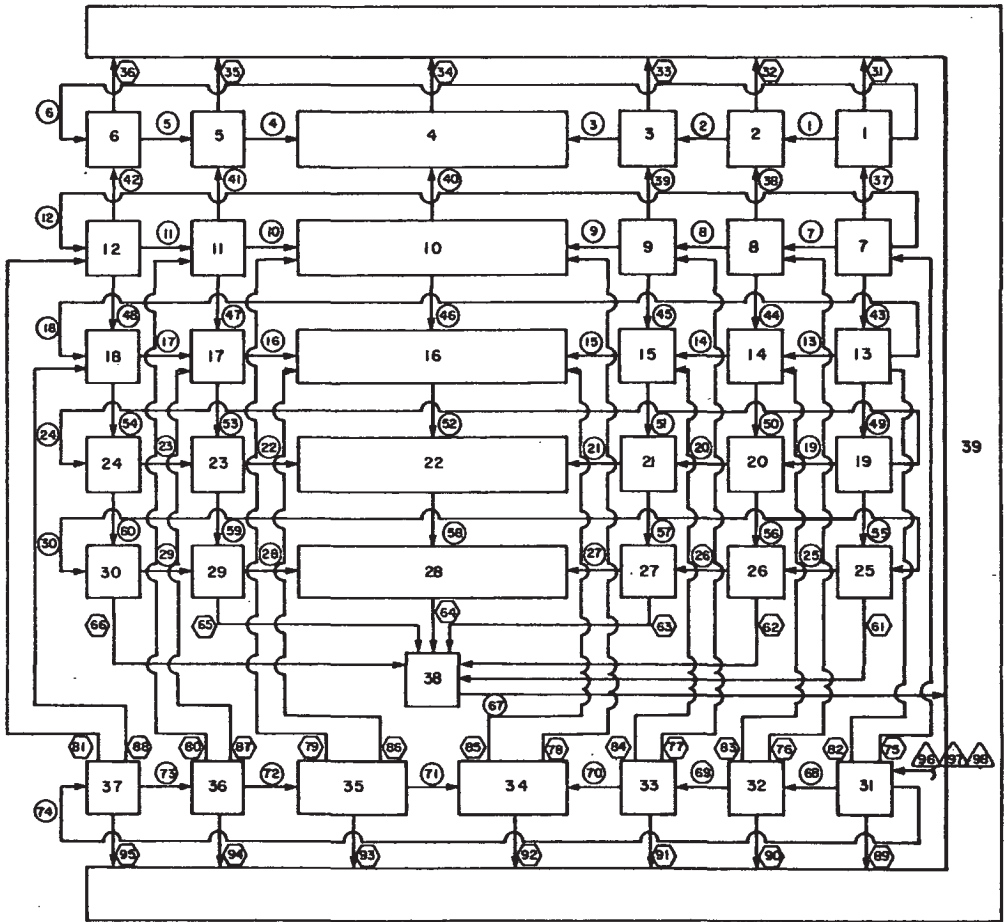

- NODE
- INCOMPRESSIBLE FLOW PATH
- △ FILL PATH
- ⬡ COMPRESSIBLE FLOW PATH

BYRON/BRAIDWOOD STATIONS
 UPDATED FINAL SAFETY ANALYSIS REPORT
 FIGURE 6.2-18a
 NODALIZATION SCHEMATIC

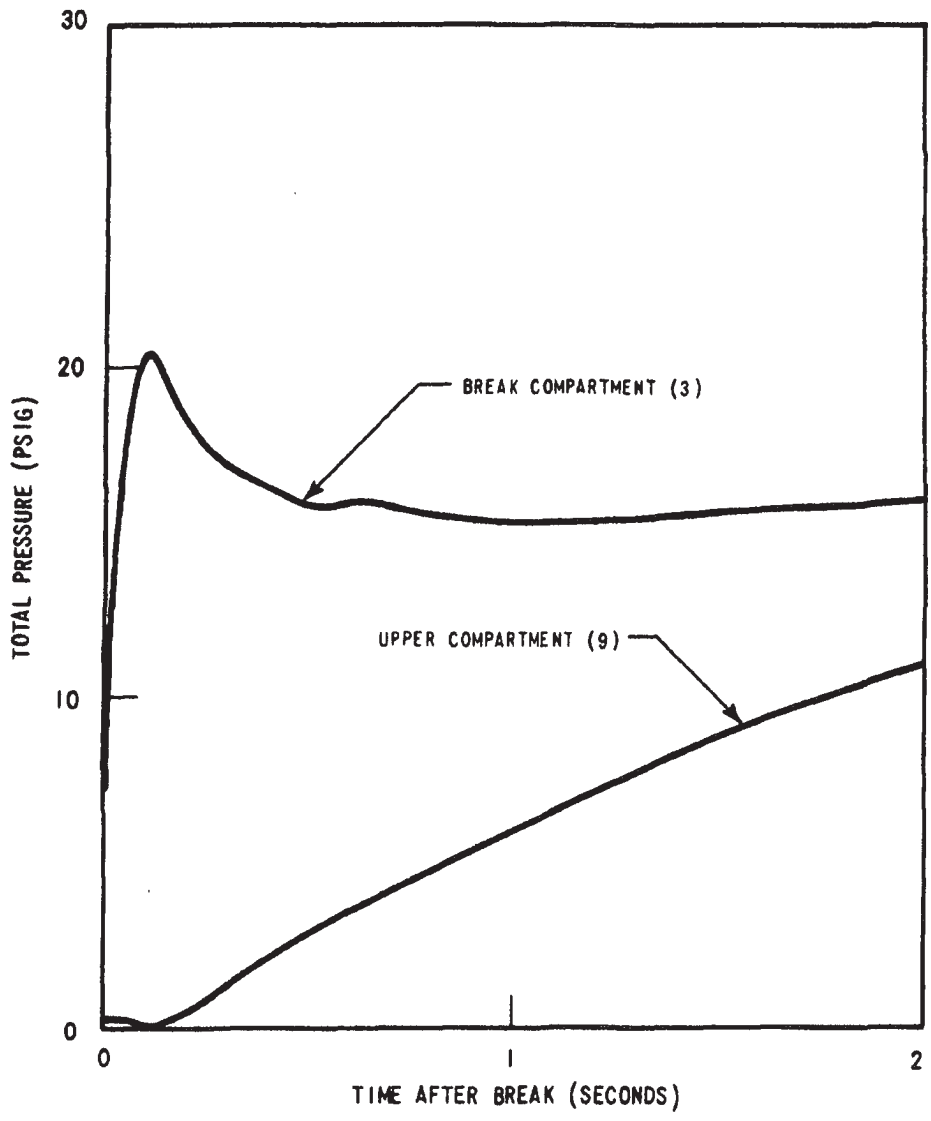

See subsection 6.2.1.2.1. These are loop compartment controlling loads. They need not be considered due to primary coolant loop leak-before-break analysis.

BYRON/BRAIDWOOD STATION
UPDATED FINAL SAFETY ANALYSIS REPORT

FIGURE 6.2-19
LOOP COMPARTMENT AND UPPER COMPARTMENT
PRESSURE TRANSIENT FOR WORST CASE BREAK
COMPARTMENT (ELEMENT 3) HAVING A DEHL BREAK

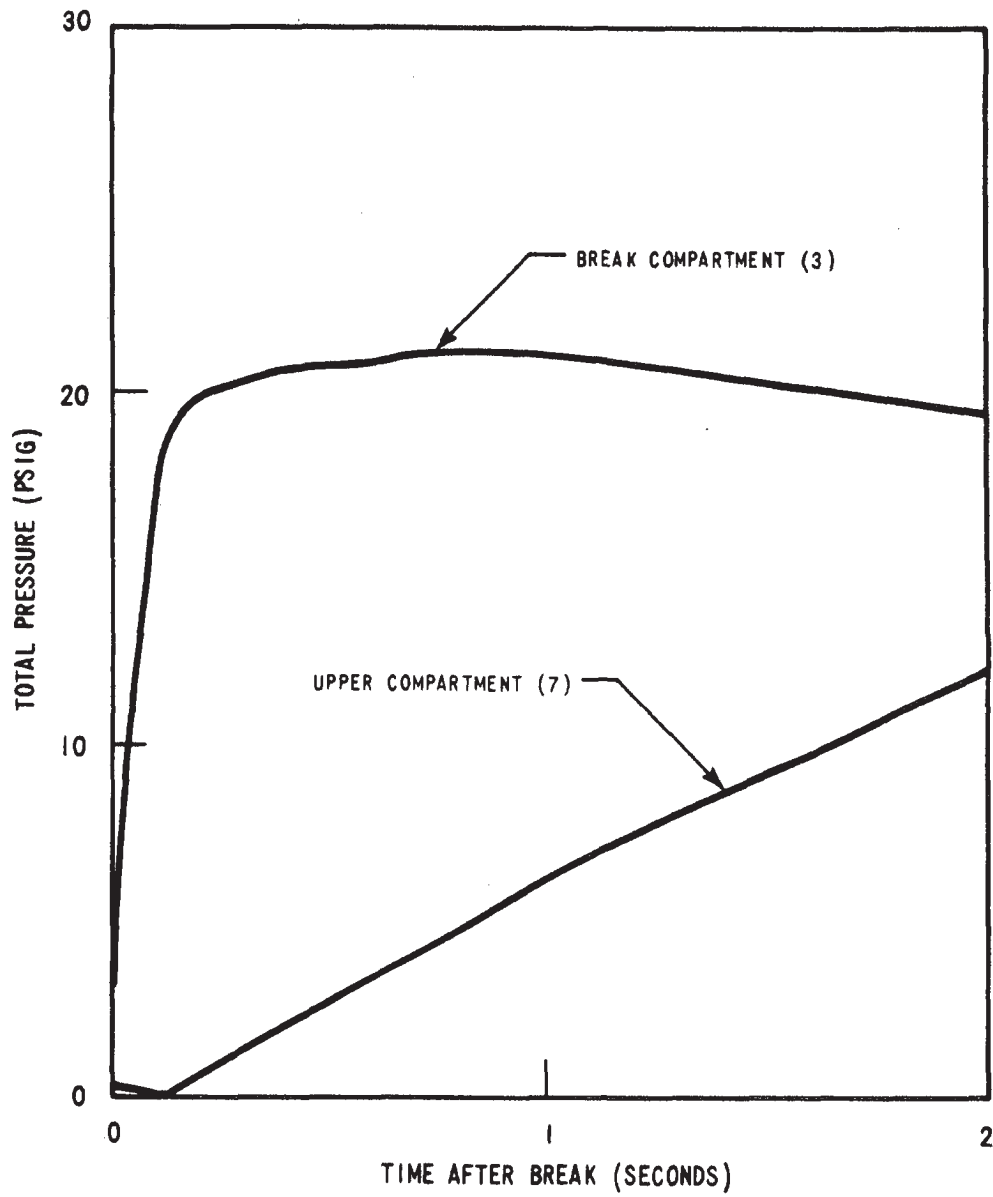

See subsection 6.2.1.2.1. These are loop compartment controlling loads. They need not be considered due to primary coolant loop leak-before-break analysis.

**BYRON/BRAIDWOOD STATIONS
UPDATED FINAL SAFETY ANALYSIS REPORT**

**FIGURE 6.2-20
LOOP COMPARTMENT AND UPPER
COMPARTMENT PRESSURE TRANSIENT FOR
WORST CASE BREAK COMPARTMENT
(ELEMENT 3) HAVING A DECL BREAK**

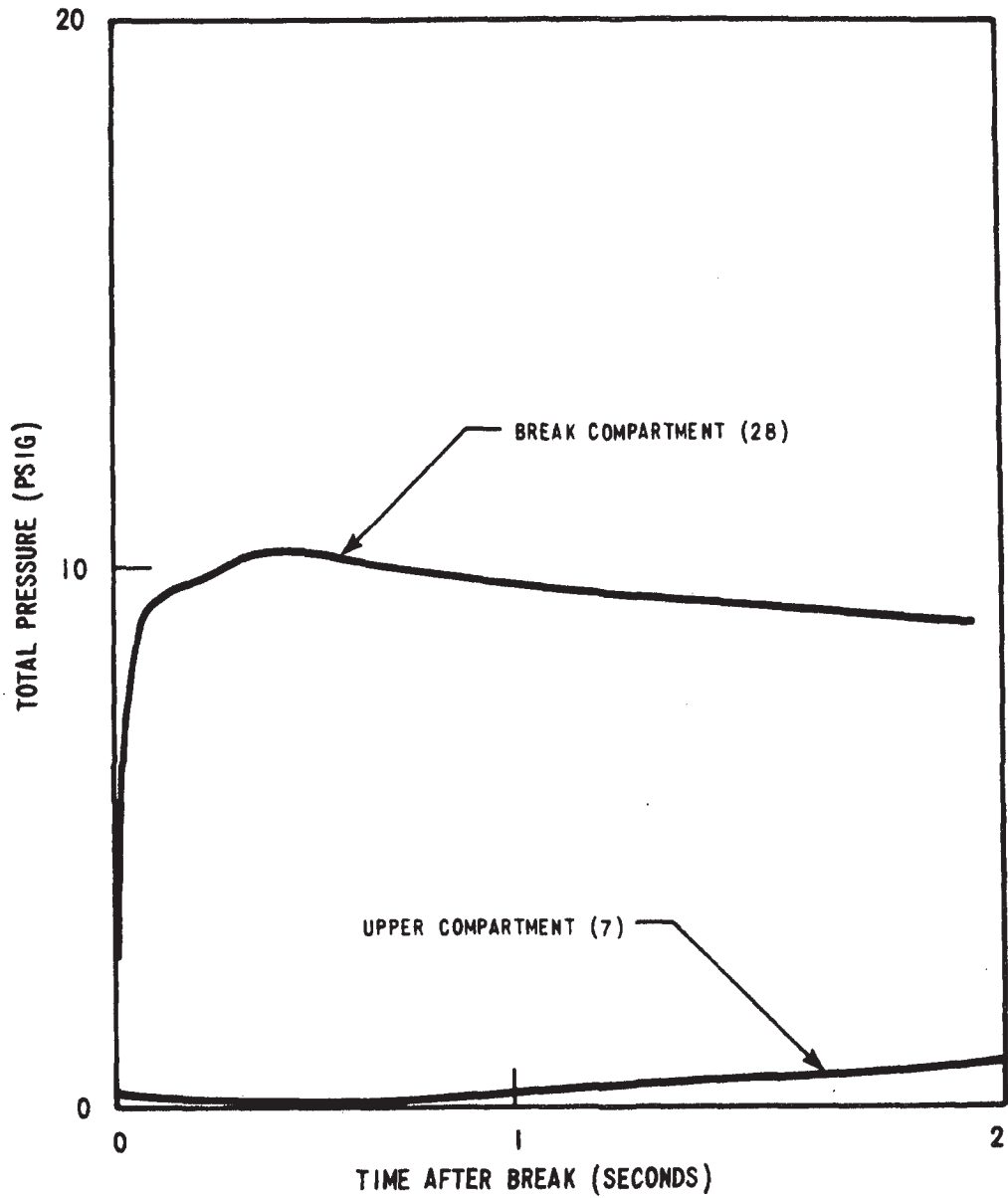

**BYRON/BRAIDWOOD STATIONS
UPDATED FINAL SAFETY ANALYSIS REPORT**

FIGURE 6.2-21

**UPPER PRESSURIZER CUBICLE AND UPPER
COMPARTMENT PRESSURE TRANSIENT FOR
SPRAY LINE BREAK (ELEMENT 28)**

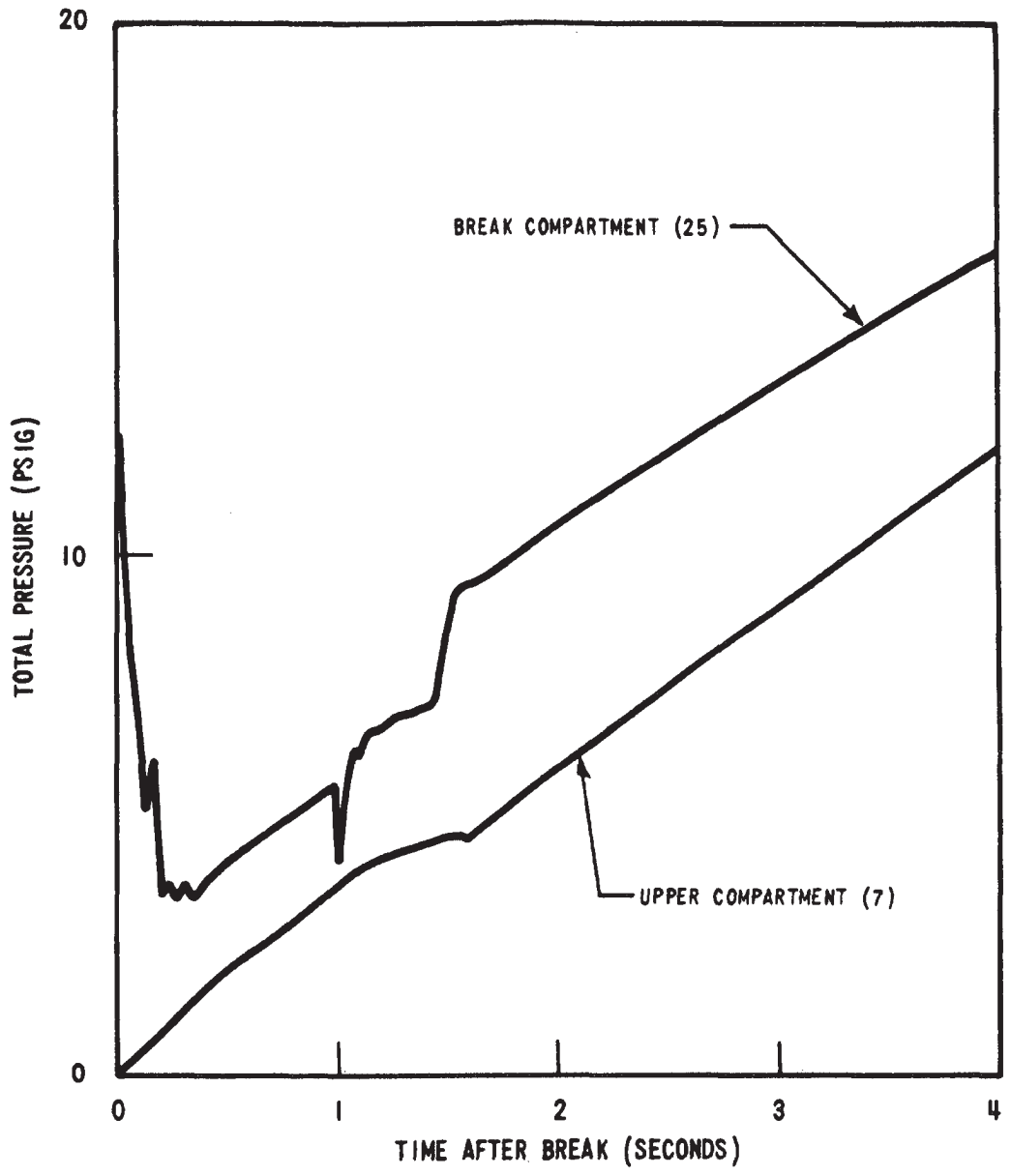

**BYRON/BRAIDWOOD STATIONS
UPDATED FINAL SAFETY ANALYSIS REPORT**

FIGURE 6.2-22

**STEAMLINE COMPARTMENT AND UPPER
COMPARTMENT PRESSURE TRANSIENT FOR
STEAMLINE BREAK (ELEMENT 25)**

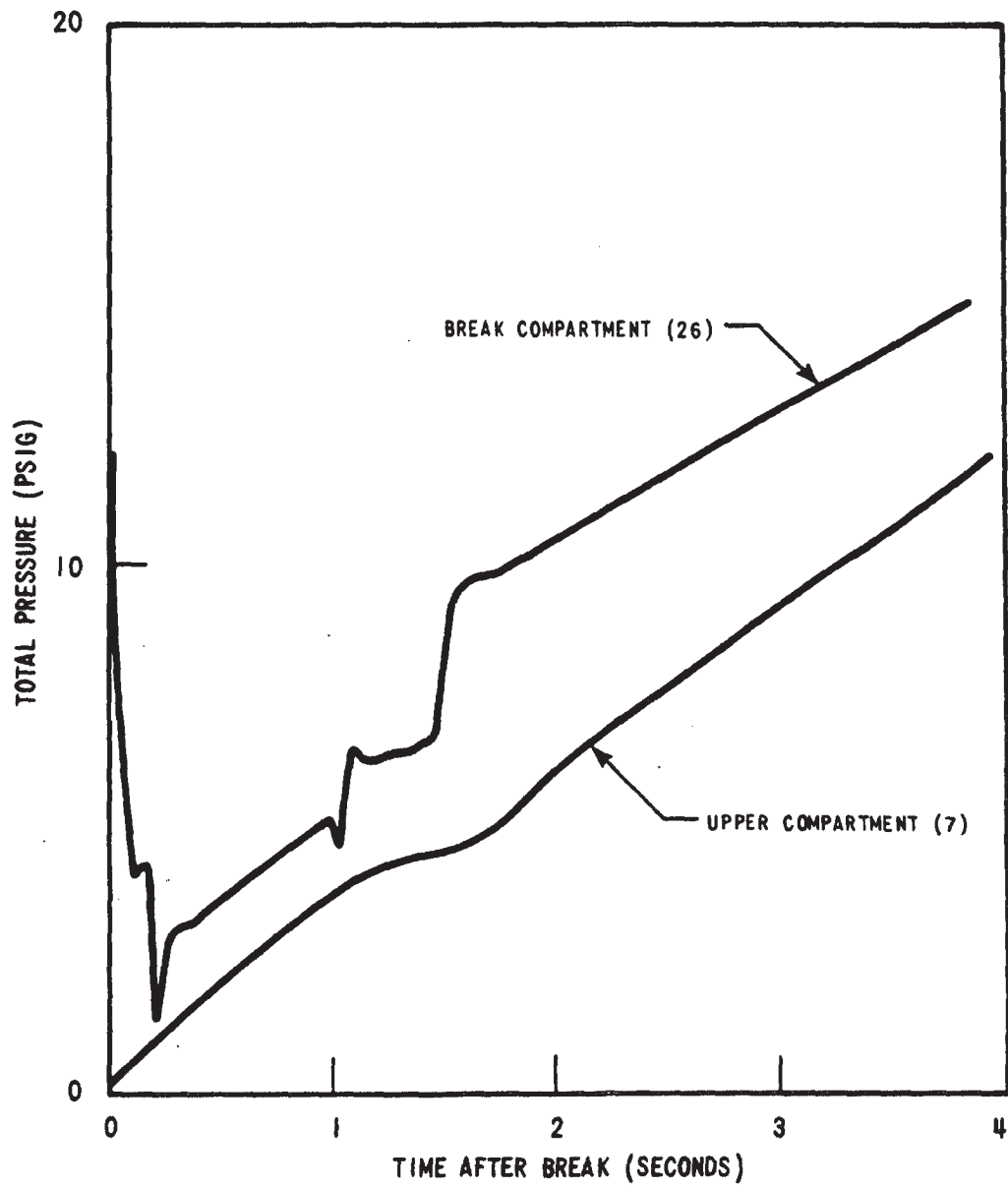

**BYRON/BRAIDWOOD STATIONS
UPDATED FINAL SAFETY ANALYSIS REPORT**

FIGURE 6.2-23

**STEAMLINE COMPARTMENT AND UPPER
COMPARTMENT PRESSURE TRANSIENT FOR
STEAMLINE BREAK (ELEMENT 26)**

Figure 6.2-24 has been deleted intentionally.

1252025329

By/Br Unit 1 ASTRUM COCO Confirmation

----- PWTR 0 0 0 COCO RESULT
----- PN 8 1 0 WC/T BREAK INPUT

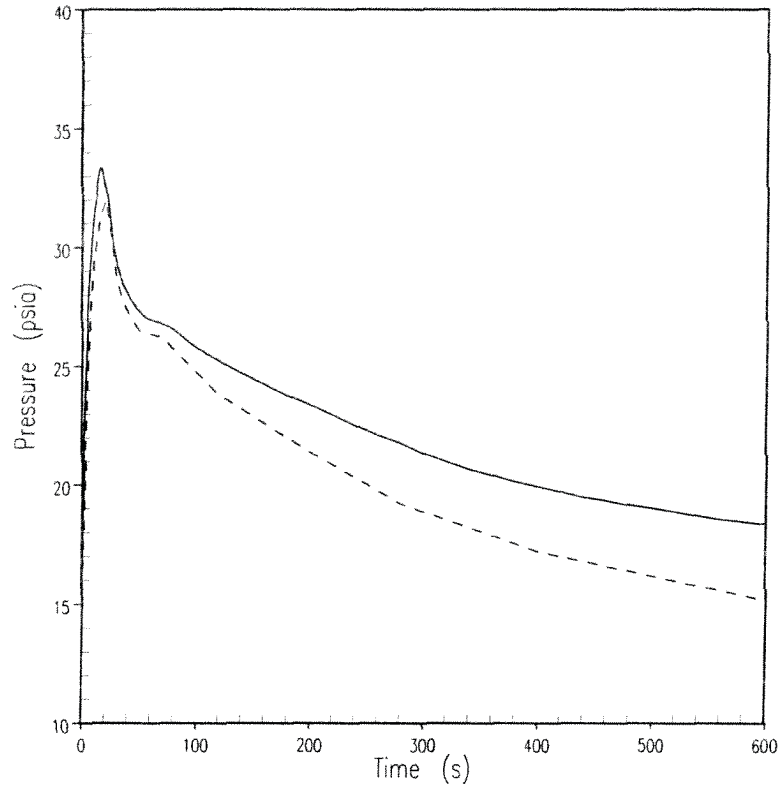

929:929:356235/17-Apr-07

BYRON/BRAIDWOOD STATIONS
UPDATED FINAL SAFETY ANALYSIS REPORT

FIGURE 6.2-24a
CONTAINMENT PRESSURE FOR ECCS LB LOCA
(UNIT 1)

566585370

By/Br Unit 2 ASTRUM COCO Confirmation

— PWTR 0 0 0 COCO RESULT
- - - PN 8 1 0 WC/T BREAK INPUT

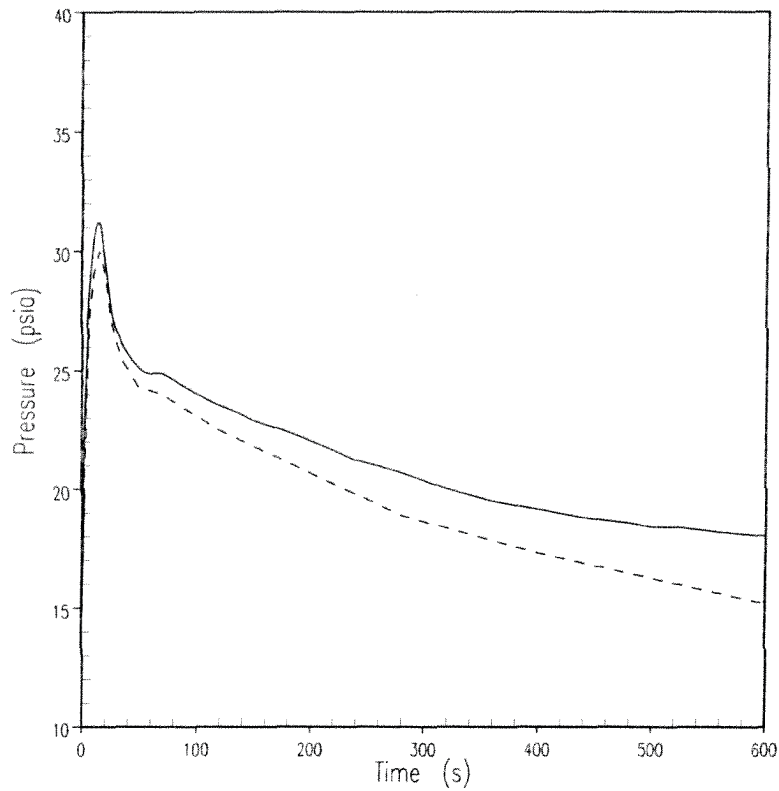

942-929-355588/16-Apr-07

BYRON/BRAIDWOOD STATIONS
UPDATED FINAL SAFETY ANALYSIS REPORT

FIGURE 6.2-24b
CONTAINMENT PRESSURE FOR ECCS LB LOCA
(UNIT 2)

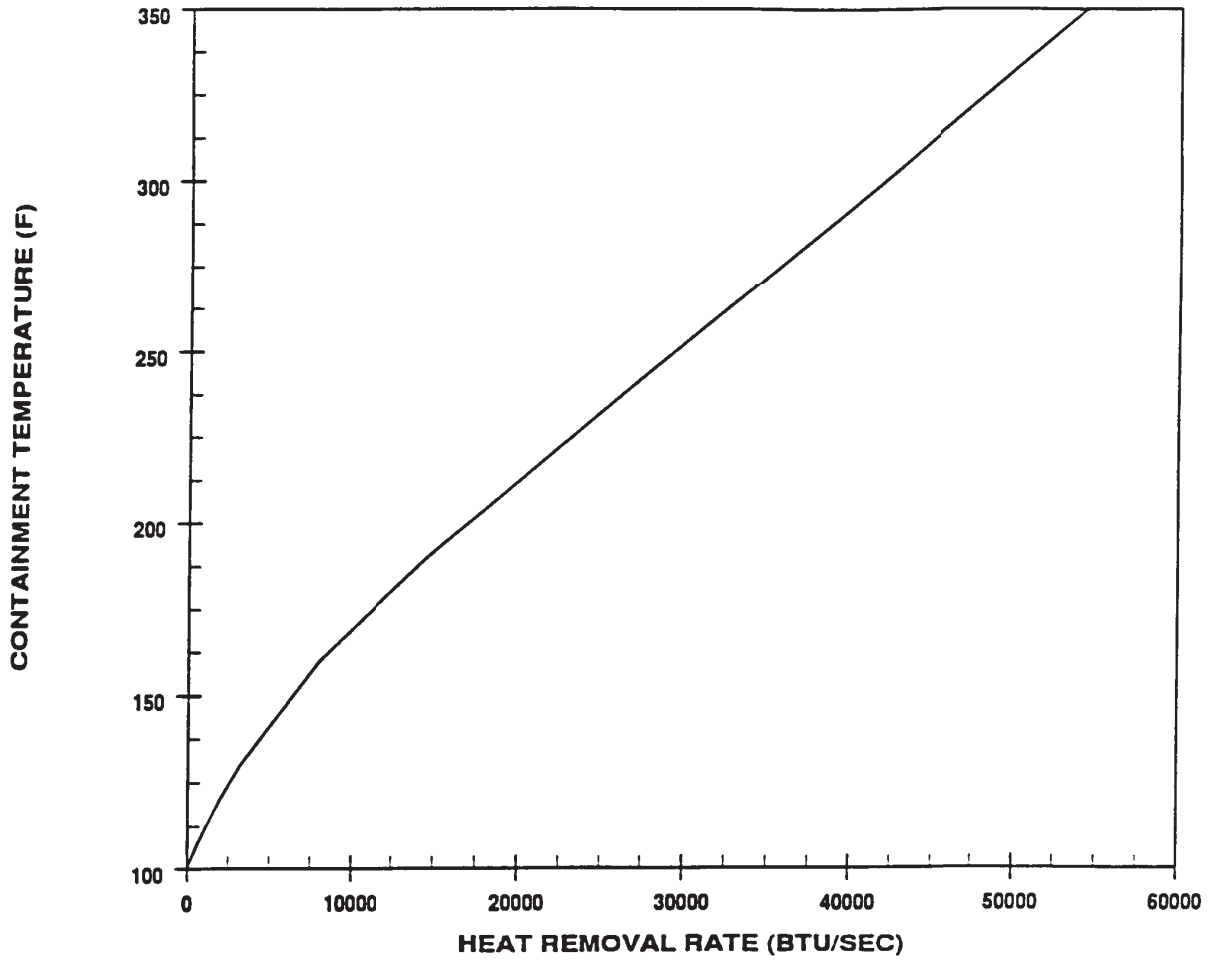

ACCIDENT MODE
ENTERING SERVICE WATER TEMP = 100 F

BYRON STATION UPDATED FINAL SAFETY ANALYSIS REPORT
FIGURE 6.2-25 ONE FAN COOLER ESTIMATED HEAT REMOVAL CAPACITY FOR CONTAINMENT RESPONSE ANALYSIS

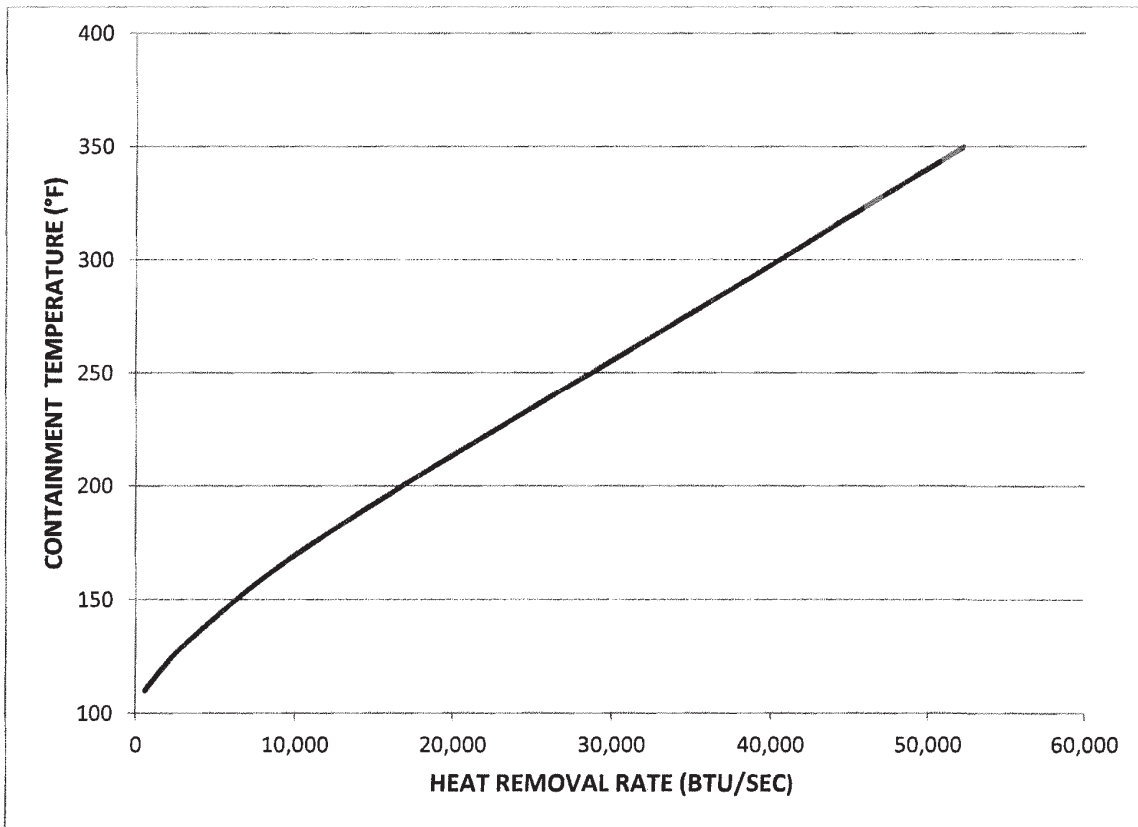

Note – The estimated heat removal capacity is based on a Service Water inlet temperature of 104 °F. The maximum initial Service Water Temperature is 102 °F. The cooler performance curve reflects the post-LOCA Ultimate Heat Sink temperature.

BRAIDWOOD STATION UPDATED FINAL SAFETY ANALYSIS REPORT
FIGURE 6.2–25 ONE FAN COOLER ESTIMATED HEAT REMOVAL CAPACITY FOR CONTAINMENT RESPONSE ANALYSIS

Heat Transfer Coefficient to Steel Exposure

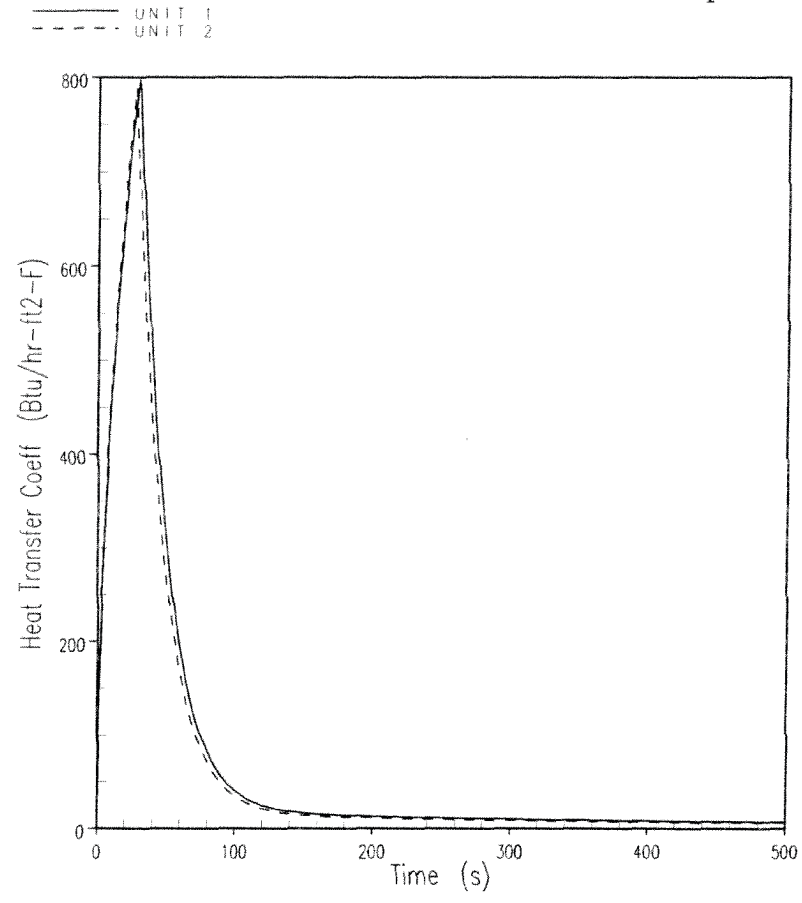

1144612097

BYRON/BRAIDWOOD STATIONS
UPDATED FINAL SAFETY ANALYSIS REPORT

FIGURE 6.2-26
HEAT TRANSFER COEFFICIENT VERSUS TIME FOR
ECCS LB LOCA REFERENCE TRANSIENT

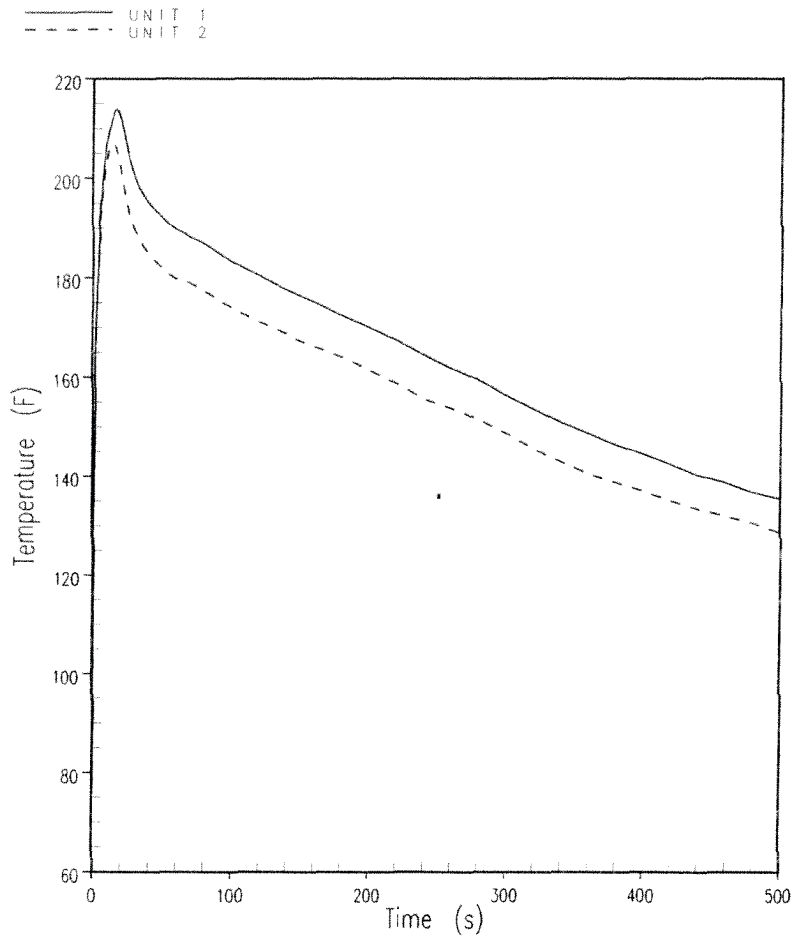

1144612097

BYRON/BRAIDWOOD STATIONS
UPDATED FINAL SAFETY ANALYSIS REPORT

FIGURE 6.2-27
CONTAINMENT AIR TEMPERATURE VERSUS TIME
FOR ECCS LB LOCA REFERENCE TRANSIENT

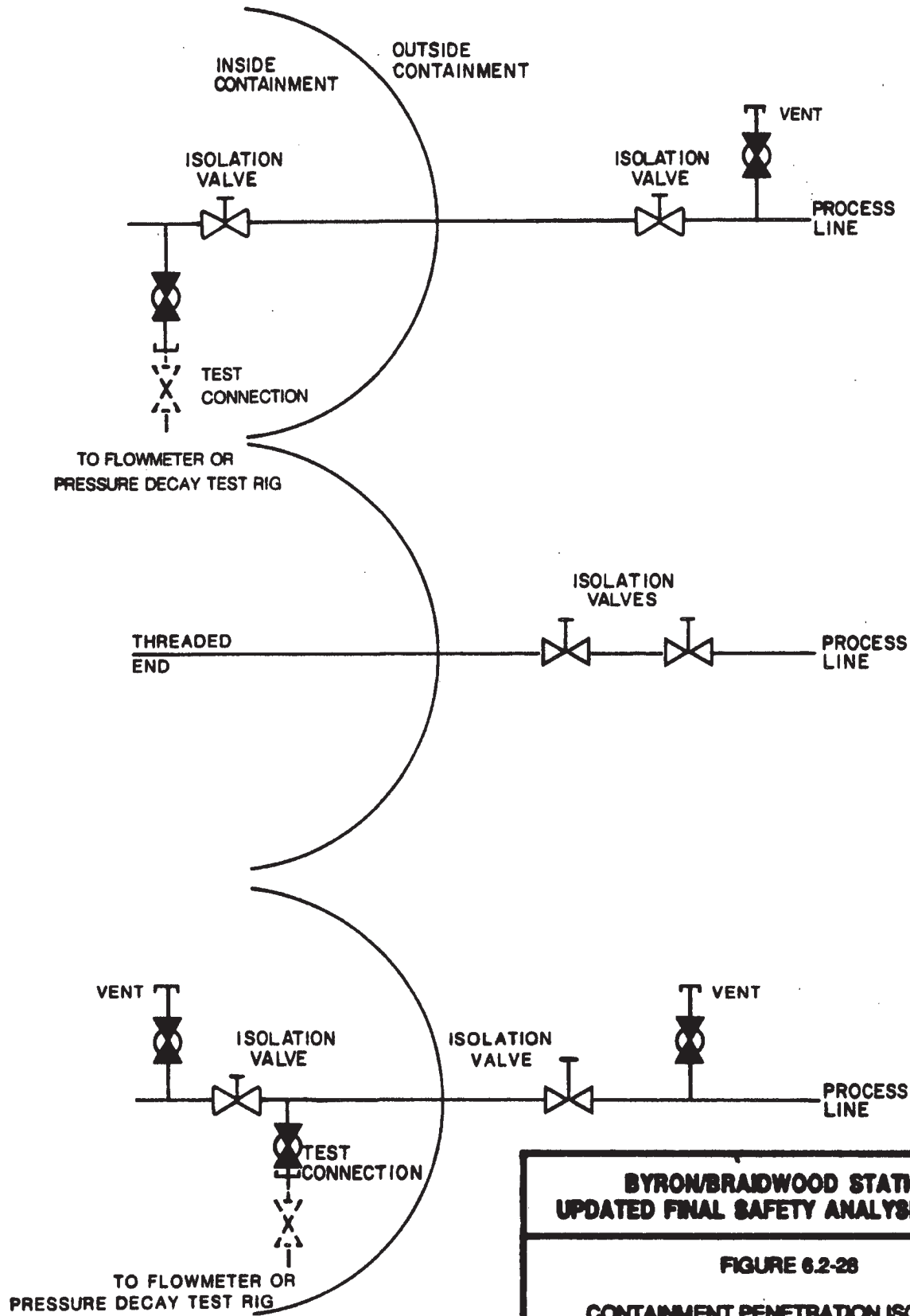

**BYRON/BRAIDWOOD STATIONS
 UPDATED FINAL SAFETY ANALYSIS REPORT**

FIGURE 6.2-28

**CONTAINMENT PENETRATION ISOLATION
 VALVE TEST CONNECTIONS**

NOTE:
 M= MANUAL
 MO= MOTOR OPERATED
 AO= AIR OPERATED
 AO/S= AIR OPERATED WITH SOLENOID
 S= SPRING LOADED NORMALLY CLOSED

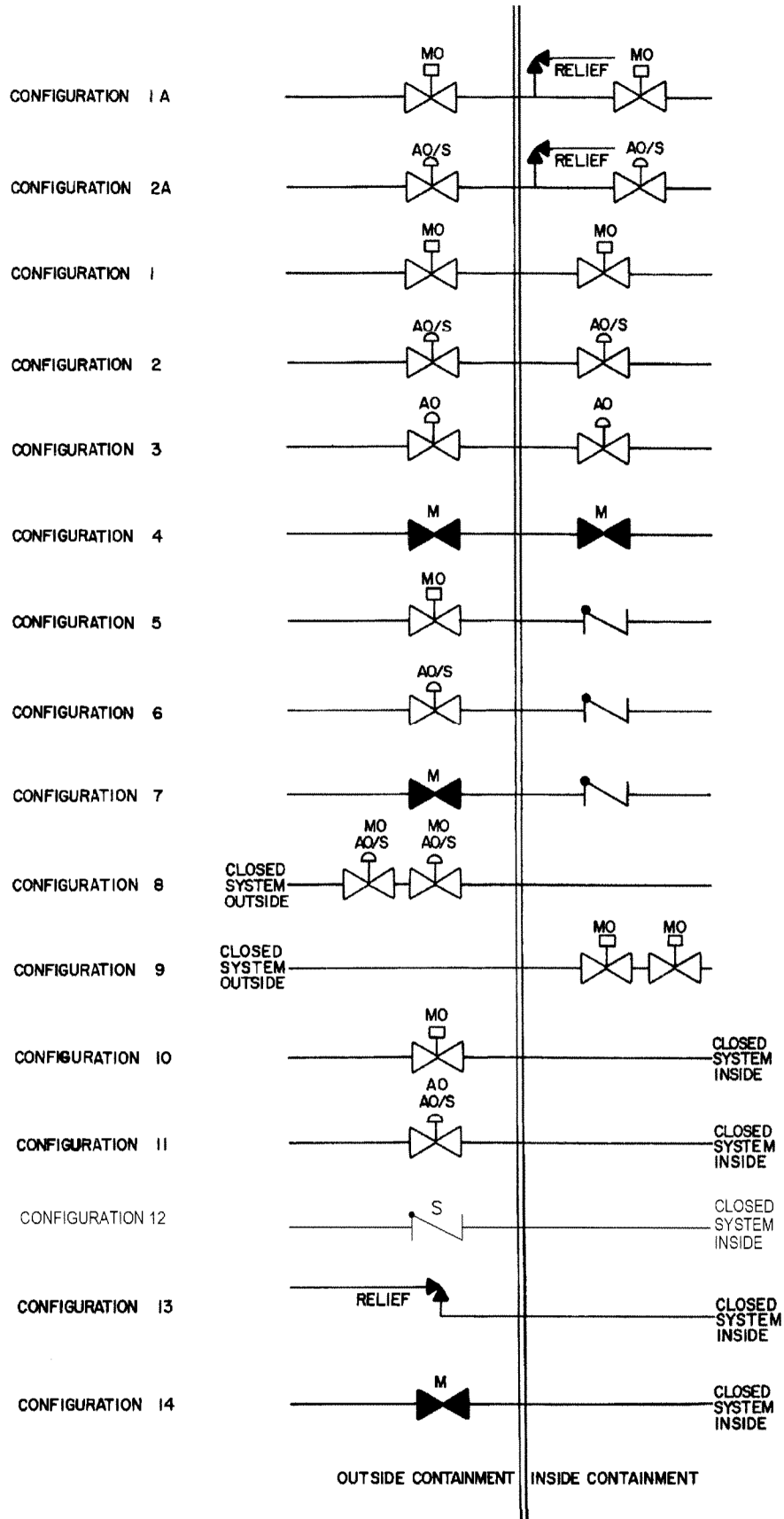

BYRON/BRATWOOD STATIONS UPDATED FINAL SAFETY ANALYSIS REPORT FIGURE 6.2-29 ISOLATION VALVE SCHEMES

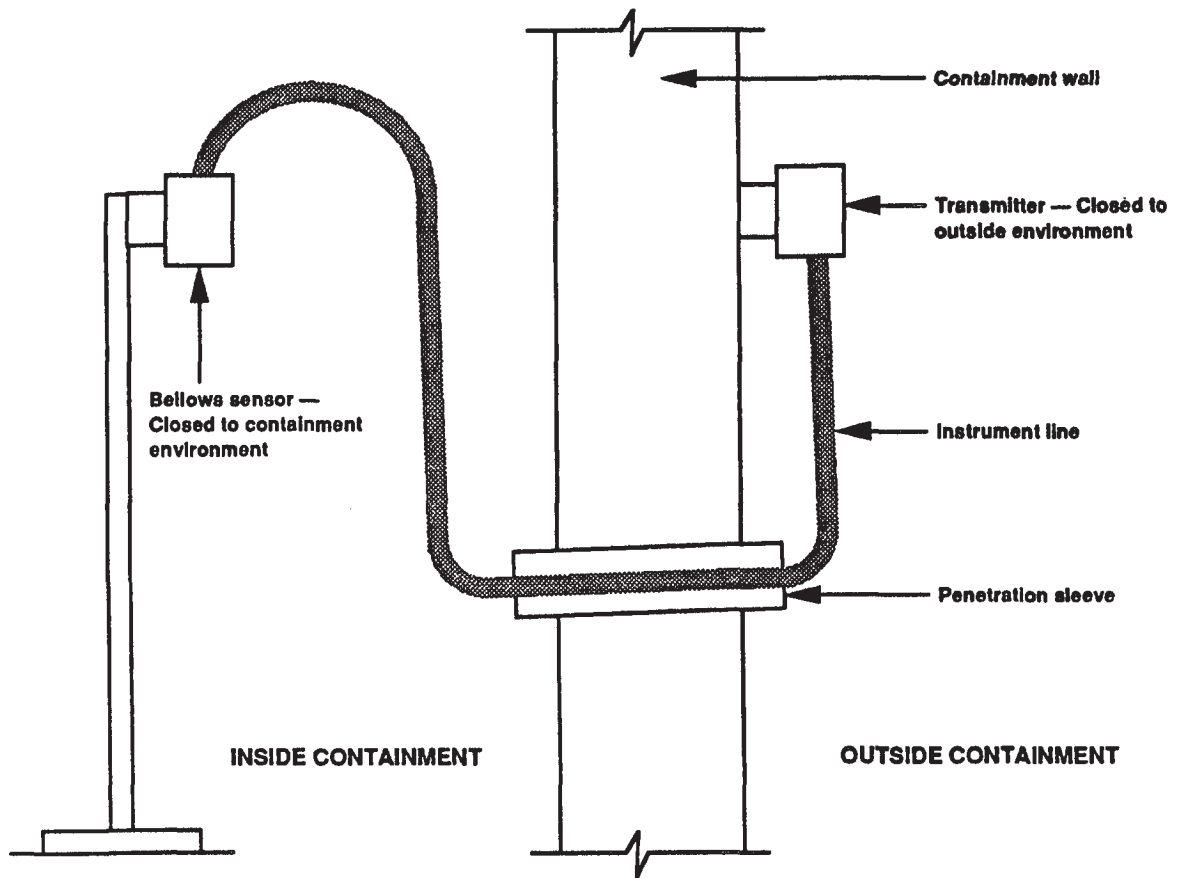

**CONTAINMENT PRESSURE AND REACTOR COOLANT SYSTEM
PRESSURE INSTRUMENT PENETRATIONS**

**BYRON/BRAIDWOOD STATIONS
UPDATED FINAL SAFETY ANALYSIS REPORT**

FIGURE 6.2-30

**INSTRUMENTATION PENETRATION SCHEME
(SHEET 1 OF 3)**

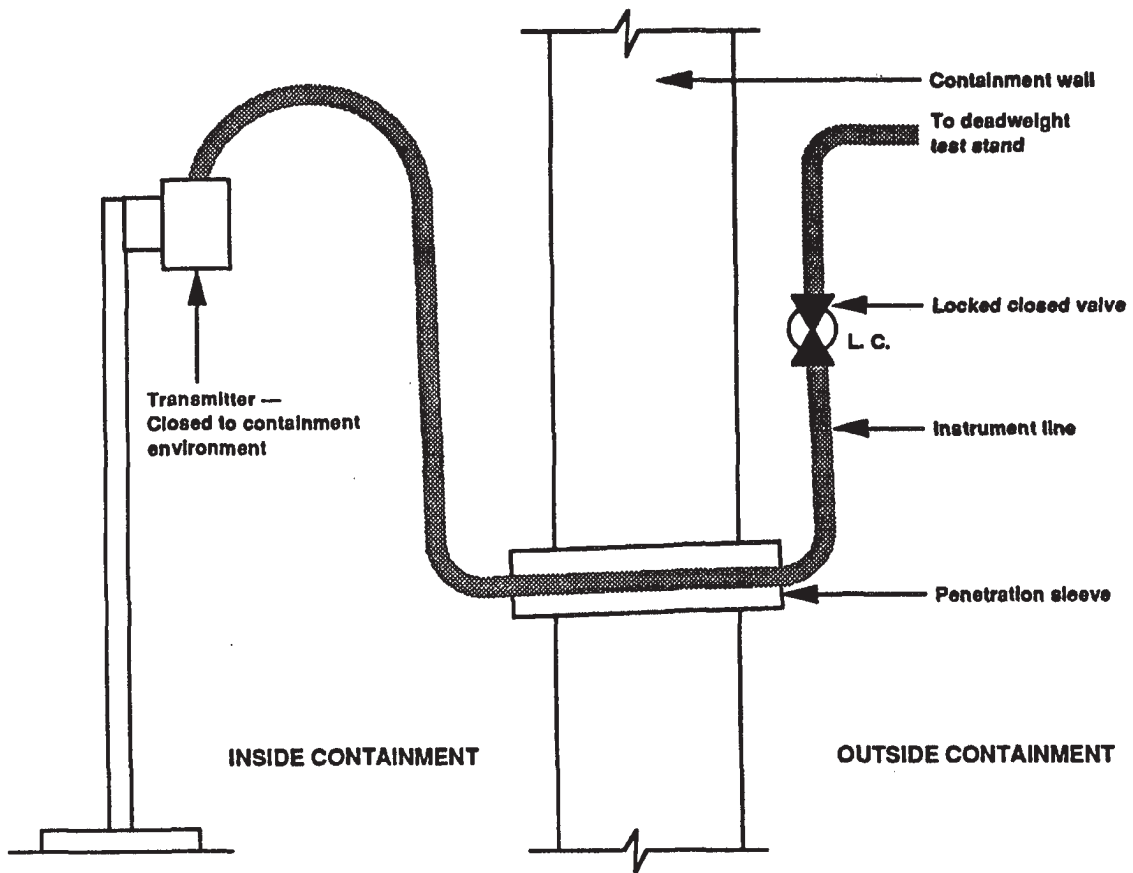

**PRESSURIZER PRESSURE TRANSMITTER DEADWEIGHT TEST STAND
CALIBRATION INSTRUMENTATION PENETRATION**

**BYRON/BRAIDWOOD STATIONS
UPDATED FINAL SAFETY ANALYSIS REPORT**

**FIGURE 6.2-30
INSTRUMENTATION PENETRATION SCHEME
(SHEET 2 OF 3)**

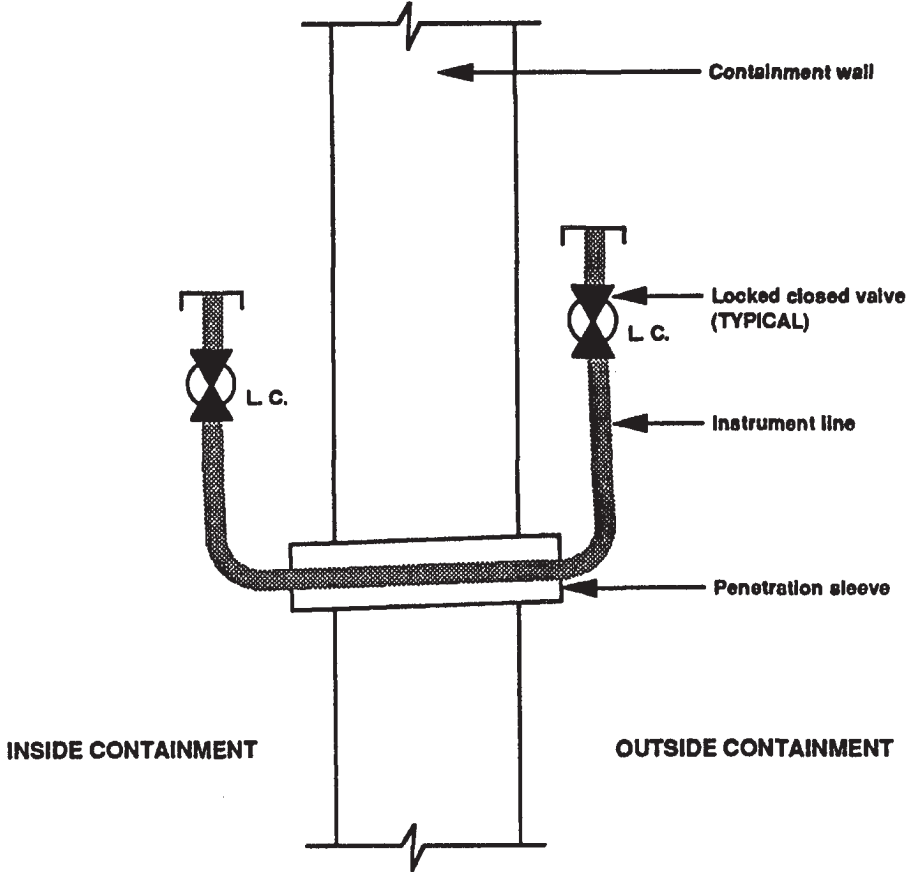

**INTEGRATED LEAK RATE TEST
INSTRUMENT PENETRATIONS**

<p>BYRON/BRAIDWOOD STATIONS UPDATED FINAL SAFETY ANALYSIS REPORT</p>
<p>FIGURE 6.2-30 INSTRUMENTATION PENETRATION SCHEME (SHEET 3 OF 3)</p>

Figures 6.2-31 through 6.2-32 have been deleted intentionally.

◆◆◆ POINTS TAKEN FROM CURVE OF SECTION 6.2.5 OF REGULATORY GUIDE 1.70

— CALCULATED RESULTS

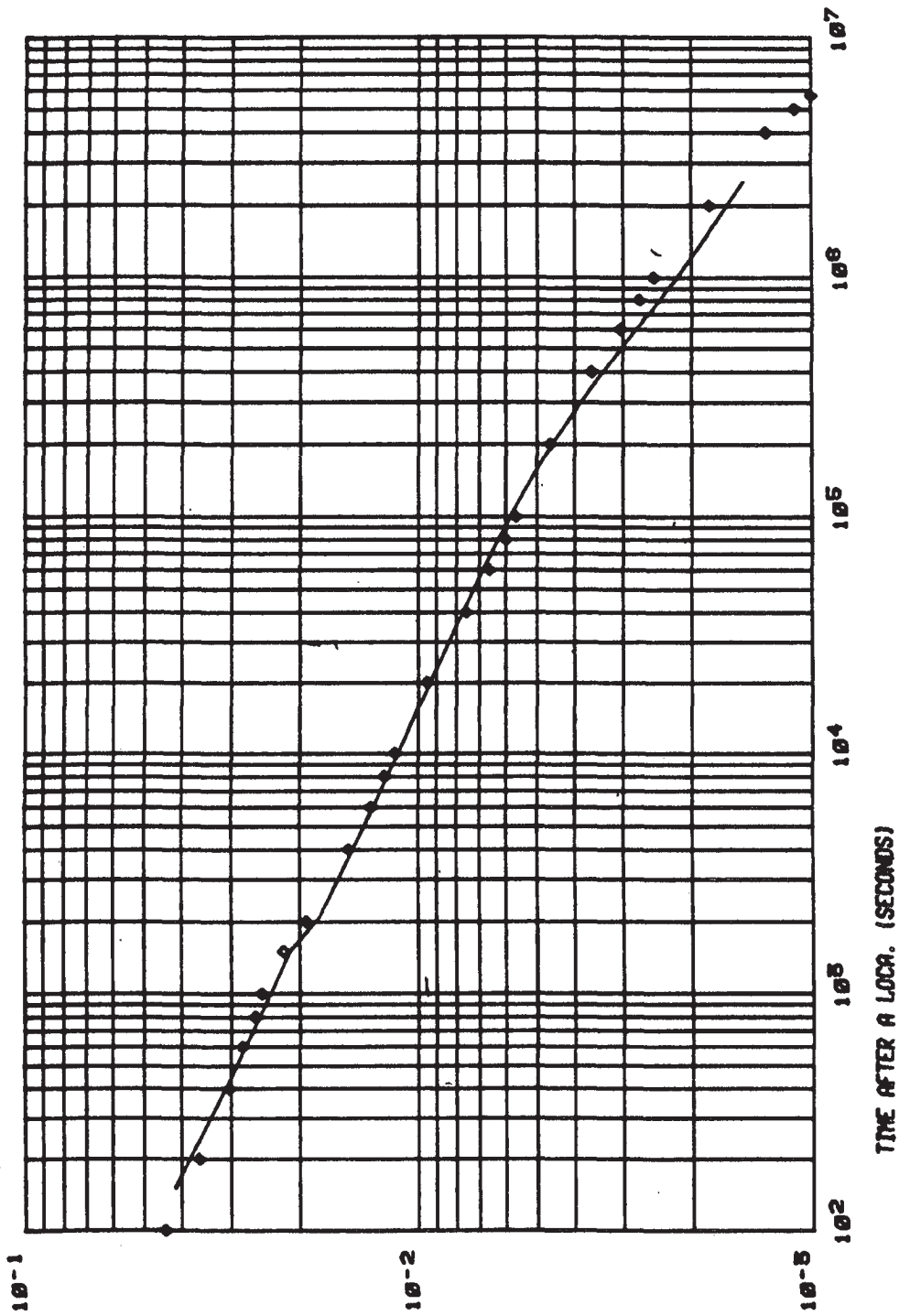

(DECAY POWER)/(OPERATING POWER)

**BYRON/BRAIDWOOD STATIONS
UPDATED FINAL SAFETY ANALYSIS REPORT**

FIGURE 6.2-33

**TOTAL RESIDUAL DECAY POWER AS A
FRACTION OF OPERATING POWER VS. TIME**

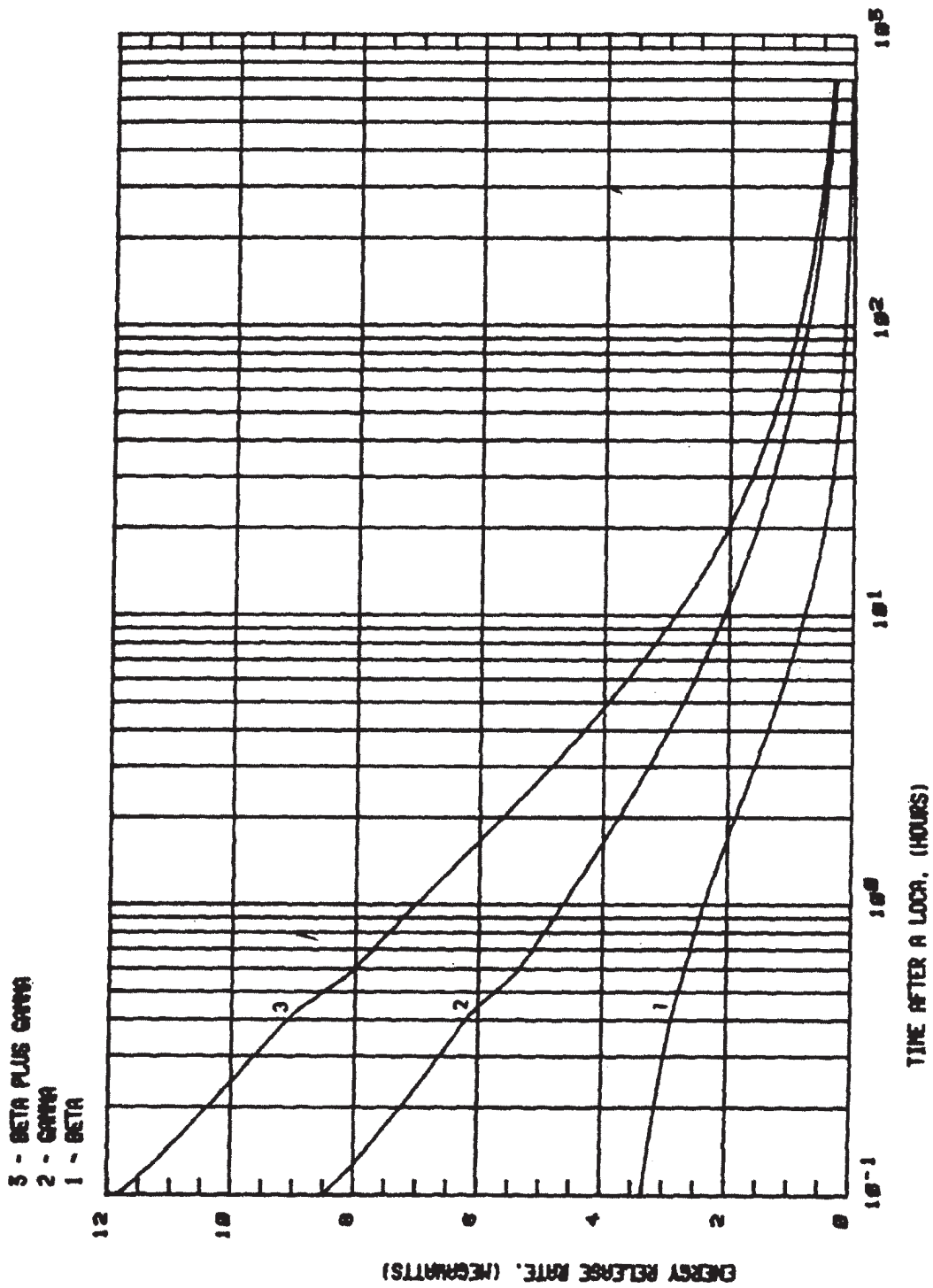

**BYRON/BRAIDWOOD STATIONS
UPDATED FINAL SAFETY ANALYSIS REPORT**

FIGURE 6.2-34

**BETA, GAMMA, AND BETA PLUS GAMMA
ENERGY RELEASE RATES VS. TIME**
(TID-14844 BASED)

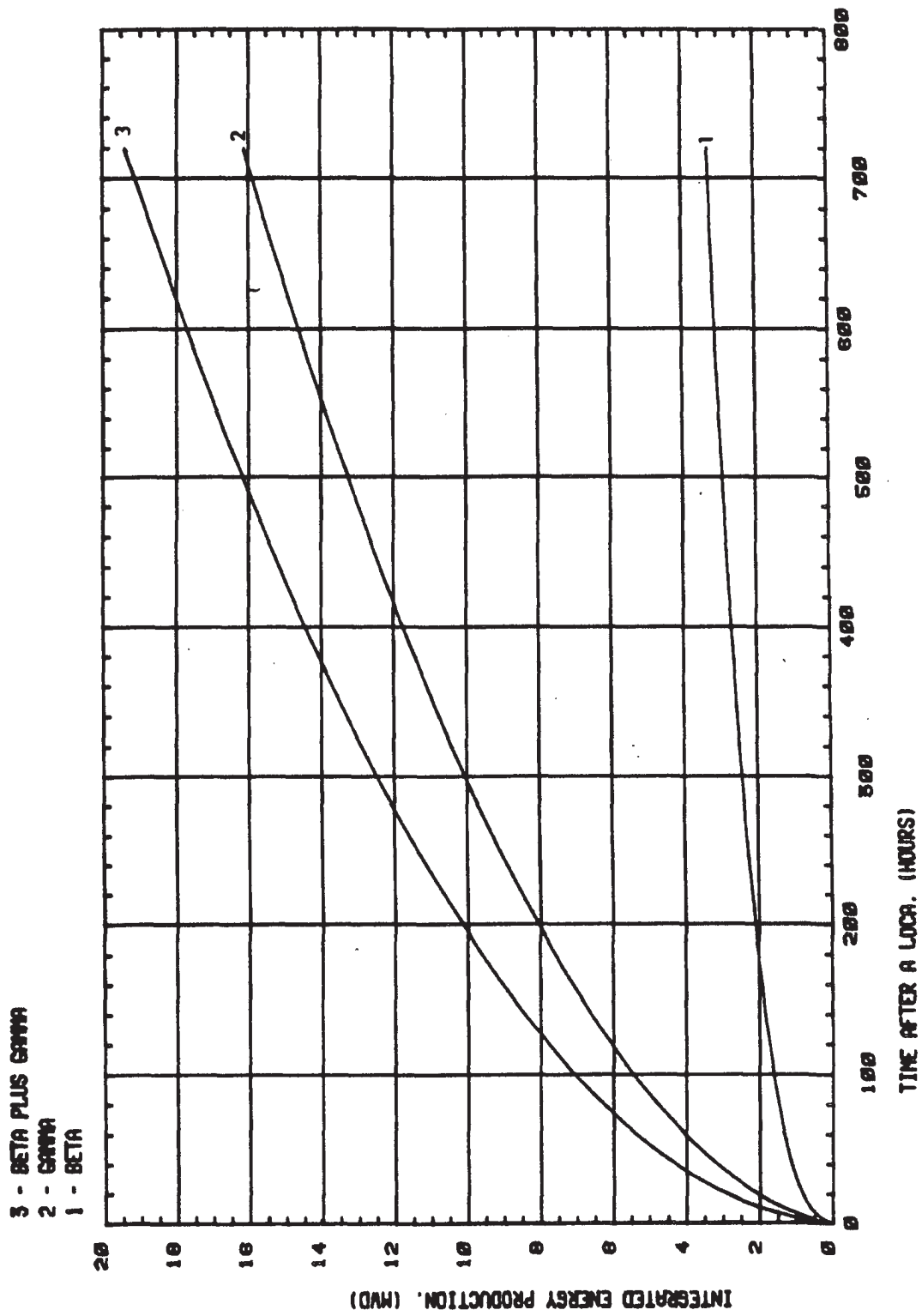

**BYRON/BRAIDWOOD STATIONS
UPDATED FINAL SAFETY ANALYSIS REPORT**

FIGURE 6.2-34a

**INTEGRATED ENERGY RELEASE OF
BETA, GAMMA, AND BETA PLUS GAMMA VS. TIME**

Figures 6.2-35 through 6.2-36 have been deleted intentionally.

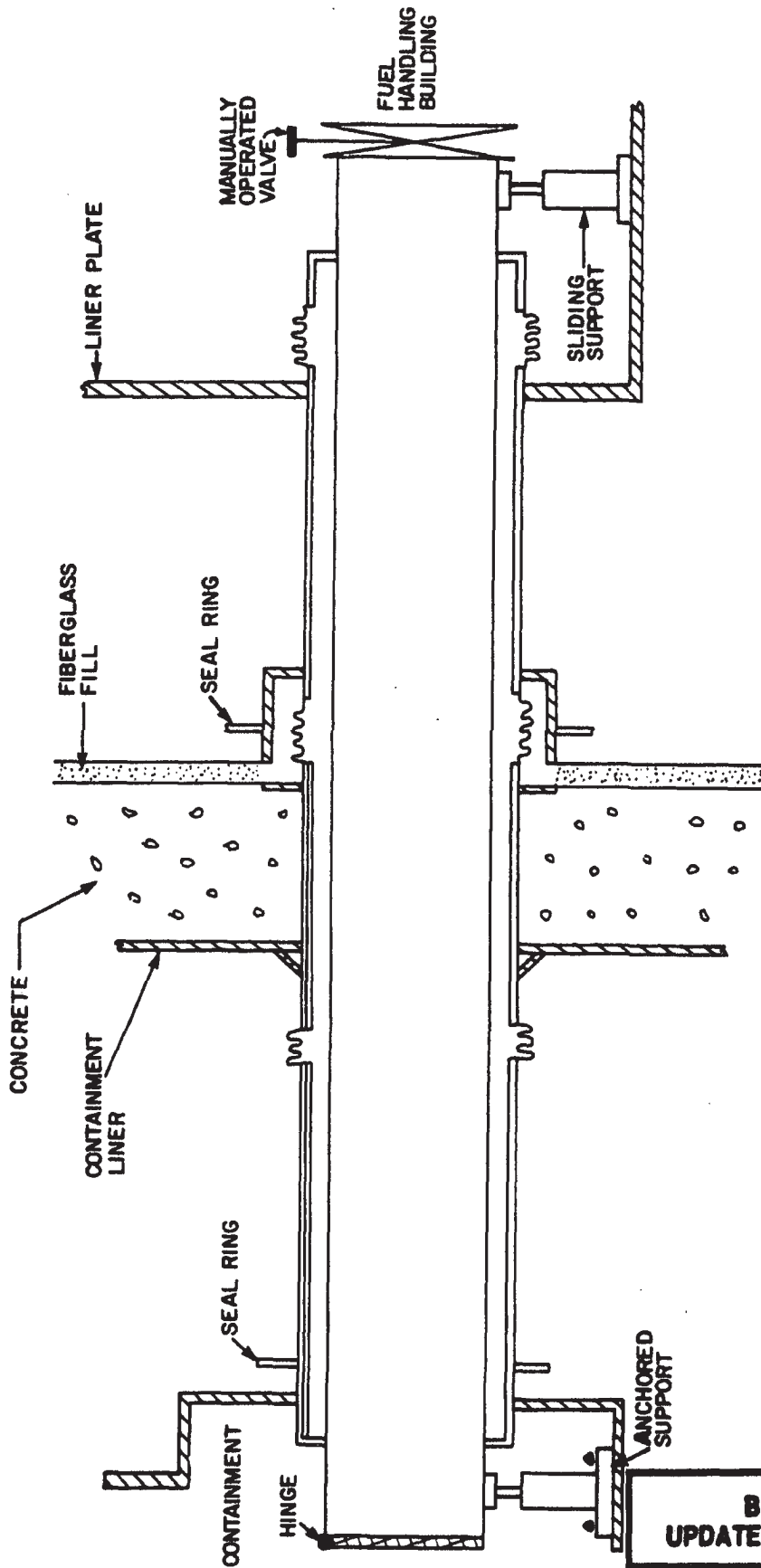

**BYRON/BRAIDWOOD STATIONS
 UPDATED FINAL SAFETY ANALYSIS REPORT**

**FIGURE 6.2-37
 FUEL TRANSFER PENETRATION**

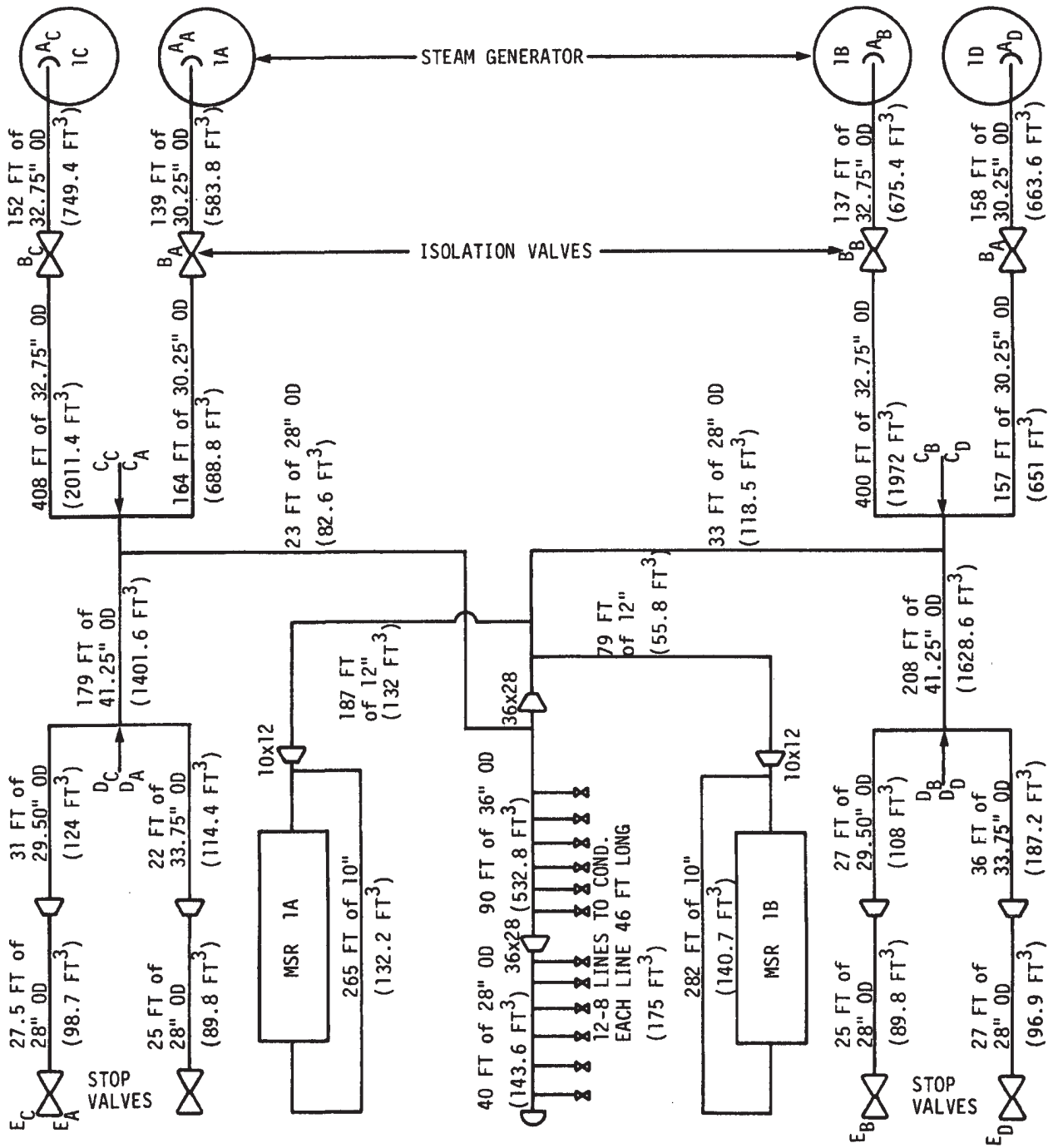

**BYRON/BRAIDWOOD STATIONS
UPDATED FINAL SAFETY ANALYSIS REPORT**

FIGURE 6.2-38

PIPING VOLUMES IN THE MAIN STEAM SYSTEM

REVISION 7
DECEMBER 1998

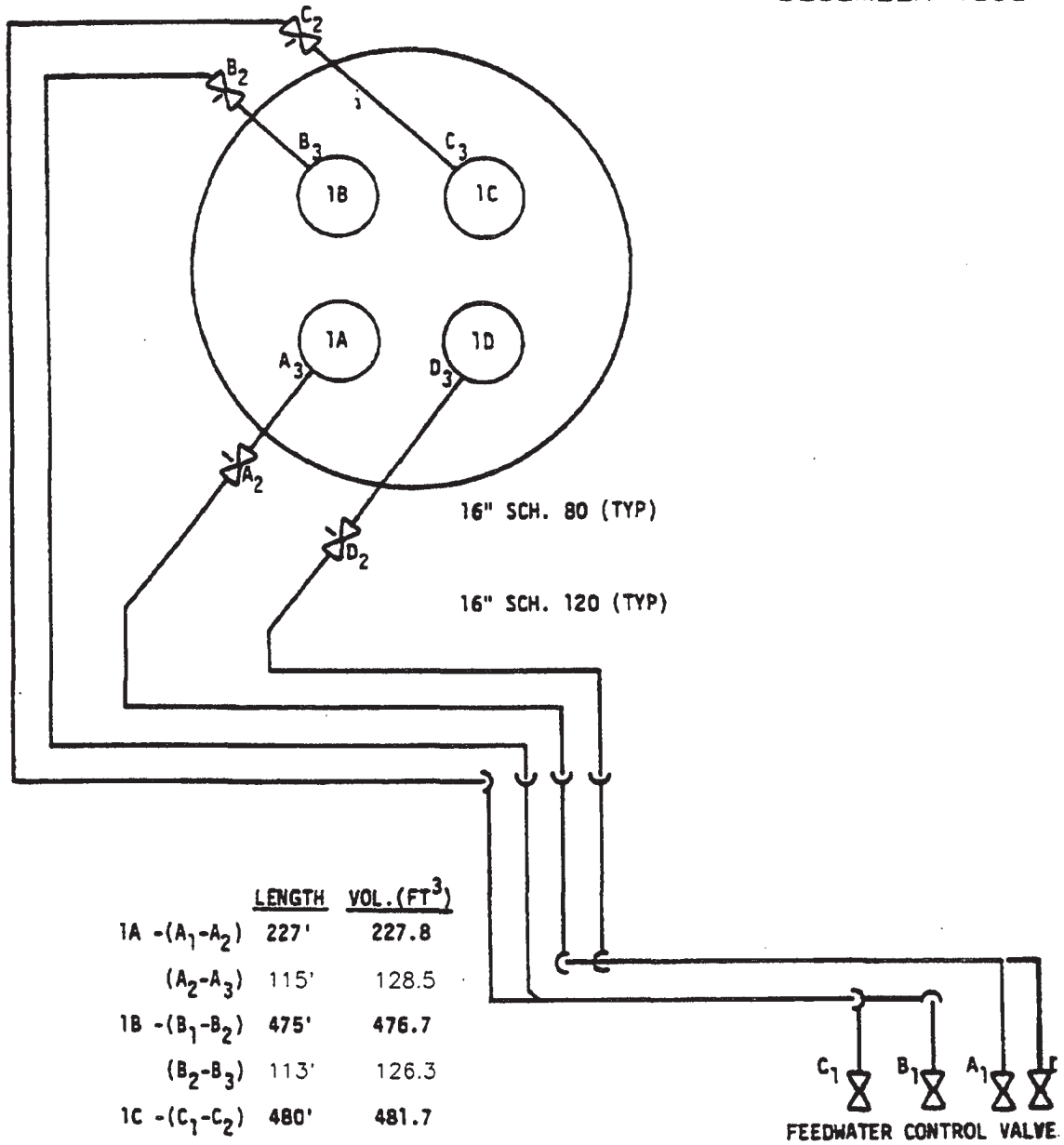

	<u>LENGTH</u>	<u>VOL. (FT³)</u>
1A -(A ₁ -A ₂)	227'	227.8
(A ₂ -A ₃)	115'	128.5
1B -(B ₁ -B ₂)	475'	476.7
(B ₂ -B ₃)	113'	126.3
1C -(C ₁ -C ₂)	480'	481.7
(C ₂ -C ₃)	155'	173.2
1D -(D ₁ -D ₂)	205'	205.7
(D ₂ -D ₃)	142'	158.7

BYRON/BRAIDWOOD STATIONS
UPDATED FINAL SAFETY ANALYSIS REPORT

FIGURE 6.2-39
PIPING VOLUMES IN THE MAIN FEEDWATER
SYSTEM (BETWEEN CONTROL VALVES
AND STEAM GENERATORS) - UNIT 1

REVISION 7
DECEMBER 1998

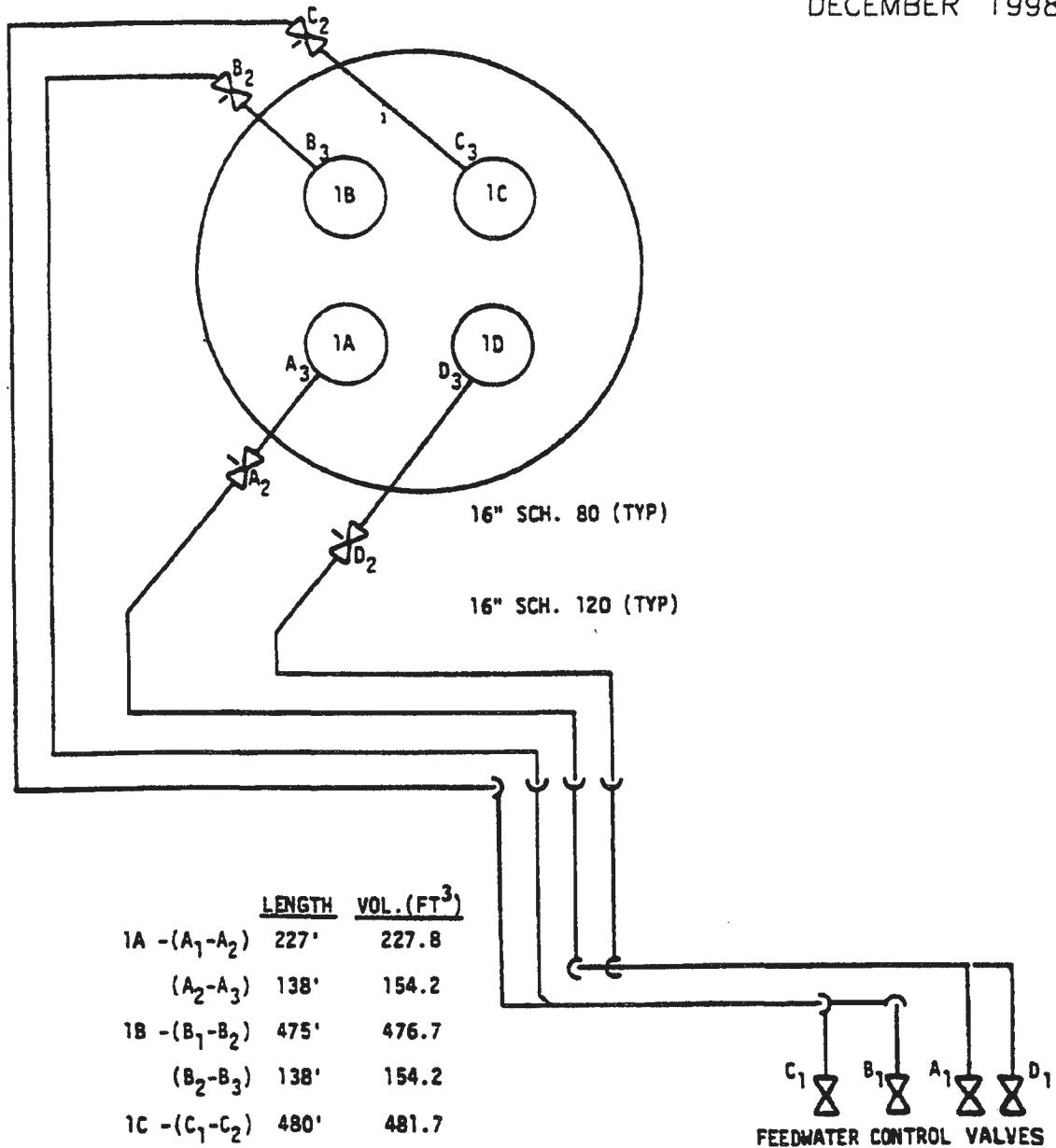

	<u>LENGTH</u>	<u>VOL. (FT³)</u>
1A -(A ₁ -A ₂)	227'	227.8
(A ₂ -A ₃)	138'	154.2
1B -(B ₁ -B ₂)	475'	476.7
(B ₂ -B ₃)	138'	154.2
1C -(C ₁ -C ₂)	480'	481.7
(C ₂ -C ₃)	155'	173.2
1D -(D ₁ -D ₂)	205'	205.7
(D ₂ -D ₃)	157'	175.4

BYRON/BRAIDWOOD STATIONS
UPDATED FINAL SAFETY ANALYSIS REPORT

FIGURE 6.2-40

PIPING VOLUMES IN THE MAIN FEEDWATER SYSTEM (BETWEEN CONTROL VALVES AND STEAM GENERATORS) - UNIT 2

Figures 6.3-1 through 6.3-2 have been deleted intentionally.

Security - Related Information Figure Withheld Under 10 CFR 2.390

BYRON/BRAIDWOOD STATIONS
UPDATED FINAL SAFETY ANALYSIS REPORT

FIGURE 6.3-2a
EMERGENCY CORE COOLING SYSTEM

B/B - UFSAR

NOTES TO FIGURE 6.3-2a

MODES OF OPERATION

MODE A - INJECTION

This mode presents the process conditions for the case of maximum safeguards, i.e., all pumps operating, following accumulator delivery. Two residual heat removal (RHR) pumps, two safety injection (SI) pumps, and two centrifugal charging (CV) pumps operate, taking suction from the refueling water storage tank and delivering to the reactor through the cold leg connections. Note that the flow from each pump is less than its maximum runout since the pump discharge piping is shared by the two pumps of each subsystem. Note also that the SI pump branch connections to the residual lines are assumed very close to their discharge into the accumulator lines, thereby eliminating any increase in the RHR branch line head loss due to the combined flows of the RHR and SI pumps.

MODE B - COLD-LEG RECIRCULATION

This mode presents the process conditions for the case of cold-leg recirculation assuming residual heat removal (RHR) pump No. 2 operating, safety injection pumps 1 and 2 operating, and centrifugal charging (CV) pumps 1 and 2 operating. It is assumed that the spray pumps have emptied the RWST at this time.

In this mode the safeguards pumps operate in series, with only the RHR pump capable of taking suction from the containment sump. The recirculated coolant is then delivered by the RHR pump to both of the SI pumps which deliver to the reactor through their cold-leg connections and to both of the CV pumps which deliver to the reactor through their cold-leg connections. The RHR pump also delivers flow directly to the reactor through two cold legs since the RHR discharge cross connect valves are closed when making the transfer from injection to recirculation.

MODE C - HOT-LEG RECIRCULATION

This mode presents the process conditions for the case of hot-leg recirculation, assuming residual heat removal (RHR) pump No. 1 operating, centrifugal charging (CV) pumps 1 and 2 operating, and safety injection (SI) pumps 1 and 2 operating.

In this mode, the safeguards pumps again operate in series with only the RHR pump taking suction from the containment sump. The recirculated coolant is then delivered by the RHR pump to both of the CV pumps which continue to deliver to the reactor through their cold-leg connections and to both of the SI pumps which deliver to the reactor through their hot-leg connections. The RHR pump also delivers directly to the reactor through two hot-leg connections.

B/B - UFSAR

VALVE ALIGNMENT CHART

OPERATIONAL MODES

VALVE NUMBER	INJECTION (A)	COLD LEG RECIRCULATION (B)	HOT LEG RECIRCULATION (C)
1 (SI8806)	O	C	C
2 (SI8812B)	O	C	C
3 (SI8812A)	O	C	C
4 (SI8814)	O	C	C
5 (SI8920)	O	C	C
6 (SI8821A)	O	O	C
7 (SI8821B)	O	O	C
8 (SI8802A)	C	C	O
9 (SI8802B)	C	C	O
10 (RH8702A and 8702B)	C C		C
11 (RH8701A and 8701B)	C C		C
12 (SI8811B)	C	O	O
13 (SI8811A)	C	O	O
14 (RH611)	C	C	C
15 (RH610)	C	C	C
16 (RH619)	C	C	C
17 (RH618)	C	C	C
18 (RH607)	O	O	O
19 (RH606)	O	O	O
20 (SI8804B)	C O		O

O = OPEN

C = CLOSED

B/B - UFSAR

VALVE ALIGNMENT CHART (Cont'd)

OPERATIONAL MODES

VALVE NUMBER	A	B	C
21 (CV8804A)	C	O	O
22 (RH8716B)	O	C	C
23 (RH8716A)	O	C	O
24 (SI8809B)	O	O	C
25 (SI8809A)	O	O	C
26 (CV112B and CV112C)	C C		C
27 (SI8840)	C	C	O
28 (SI8924)	C O		O
29 (CV8111) and CV8110	O C		C
30 (SI8801A and SI8801B)	O O		O
31 (CV112D and CV112E)	O C		C
32 (SI8835)	O	O	C
33 (SI8807A and SI8807B)	C O		O
34 (CV8114 and CV8116)	V C		C
35 (SI8813)	O C		C
36 (SI8808A, SI8808B, SI8808C and SI8808D)	O C		C
37 (CV8105 and CV8106)	C C		C

O = OPEN

C = CLOSED

V = Variable, can be open or closed dependent on reactor coolant system pressure.

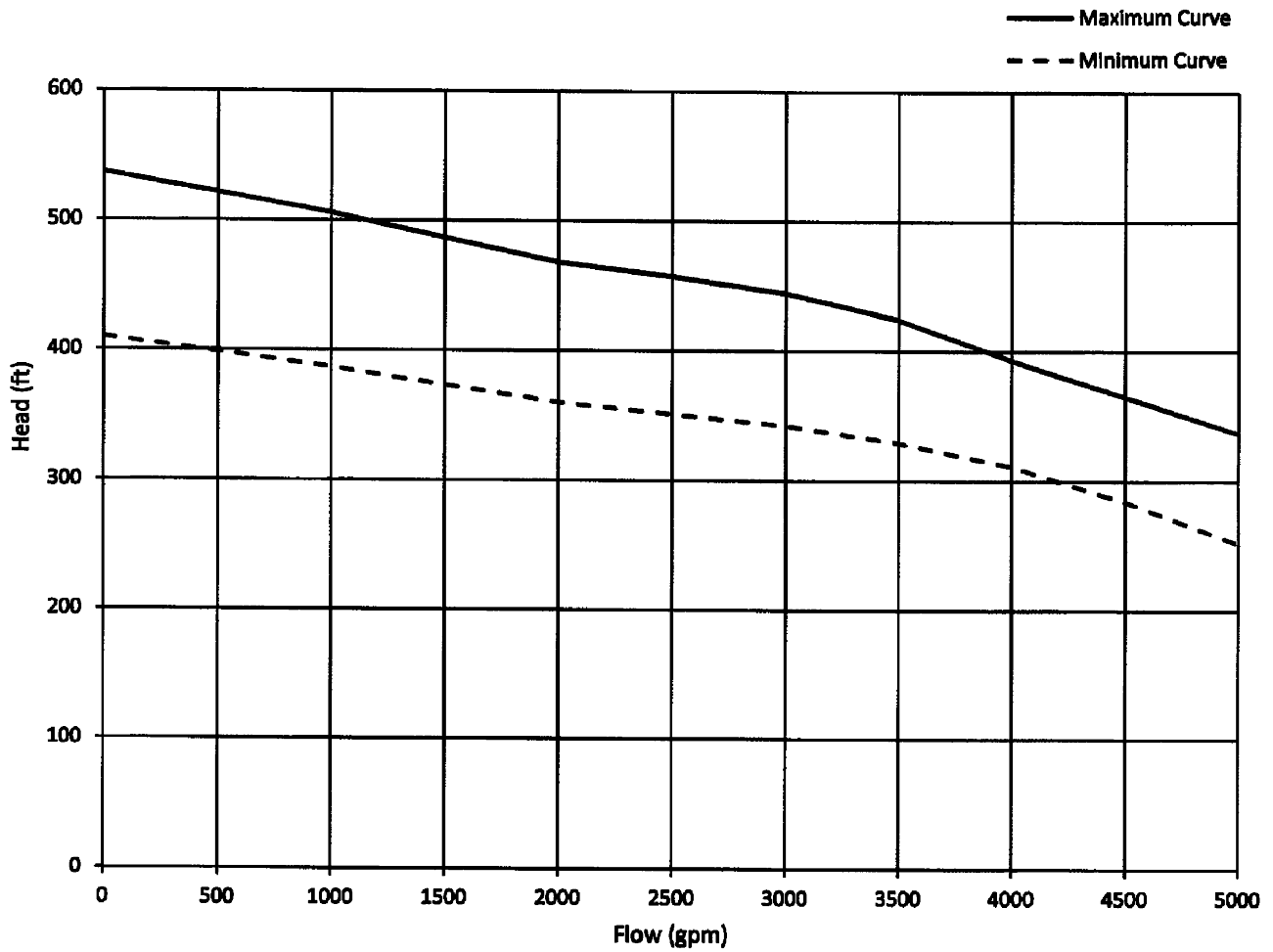

BYRON/BRAIDWOOD STATIONS
UPDATED FINAL SAFETY ANALYSIS REPORT

FIGURE 6.3-3
RESIDUAL HEAT REMOVAL PUMP
PERFORMANCE CURVE
(WITHOUT UNCERTAINTY)

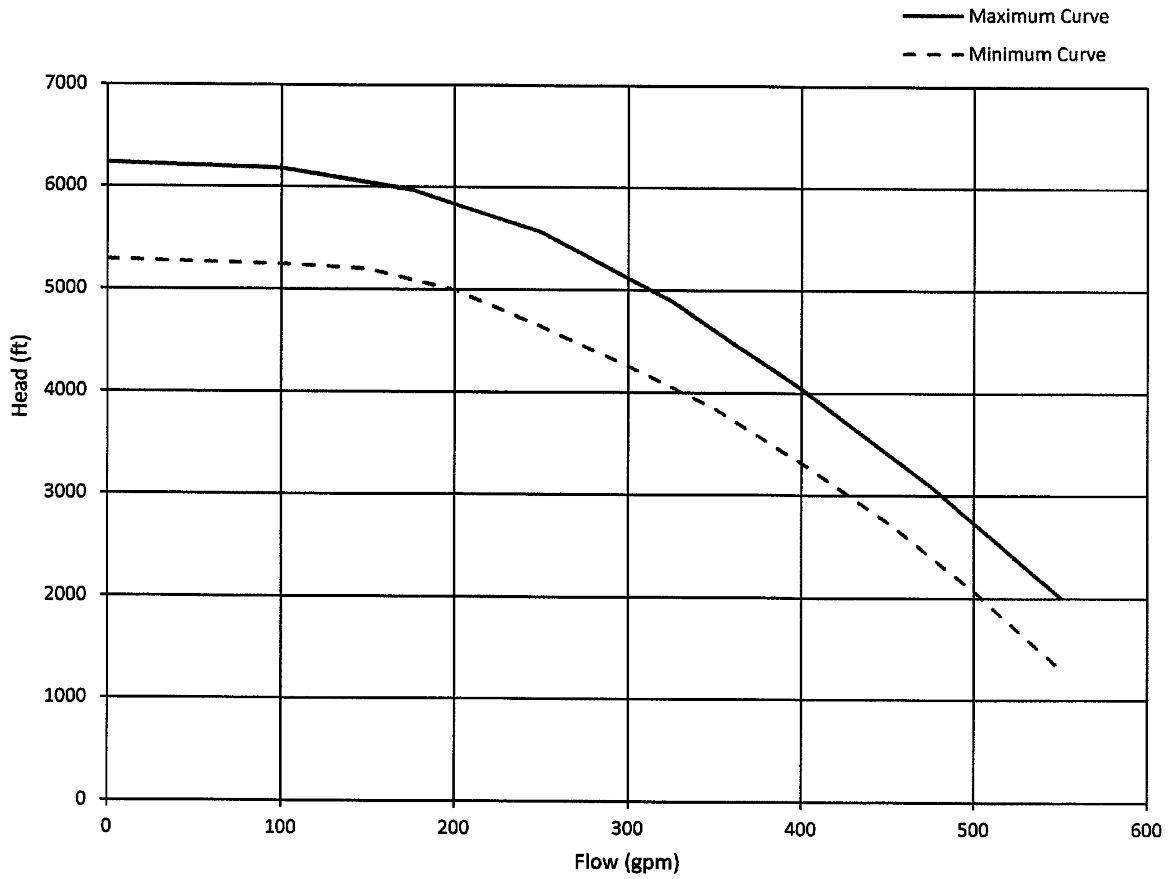

BYRON/BRAIDWOOD STATIONS
UPDATED FINAL SAFETY ANALYSIS REPORT

FIGURE 6.3-4
CENTRIFUGAL CHARGING PUMP
PERFORMANCE CURVE
(WITHOUT UNCERTAINTY)

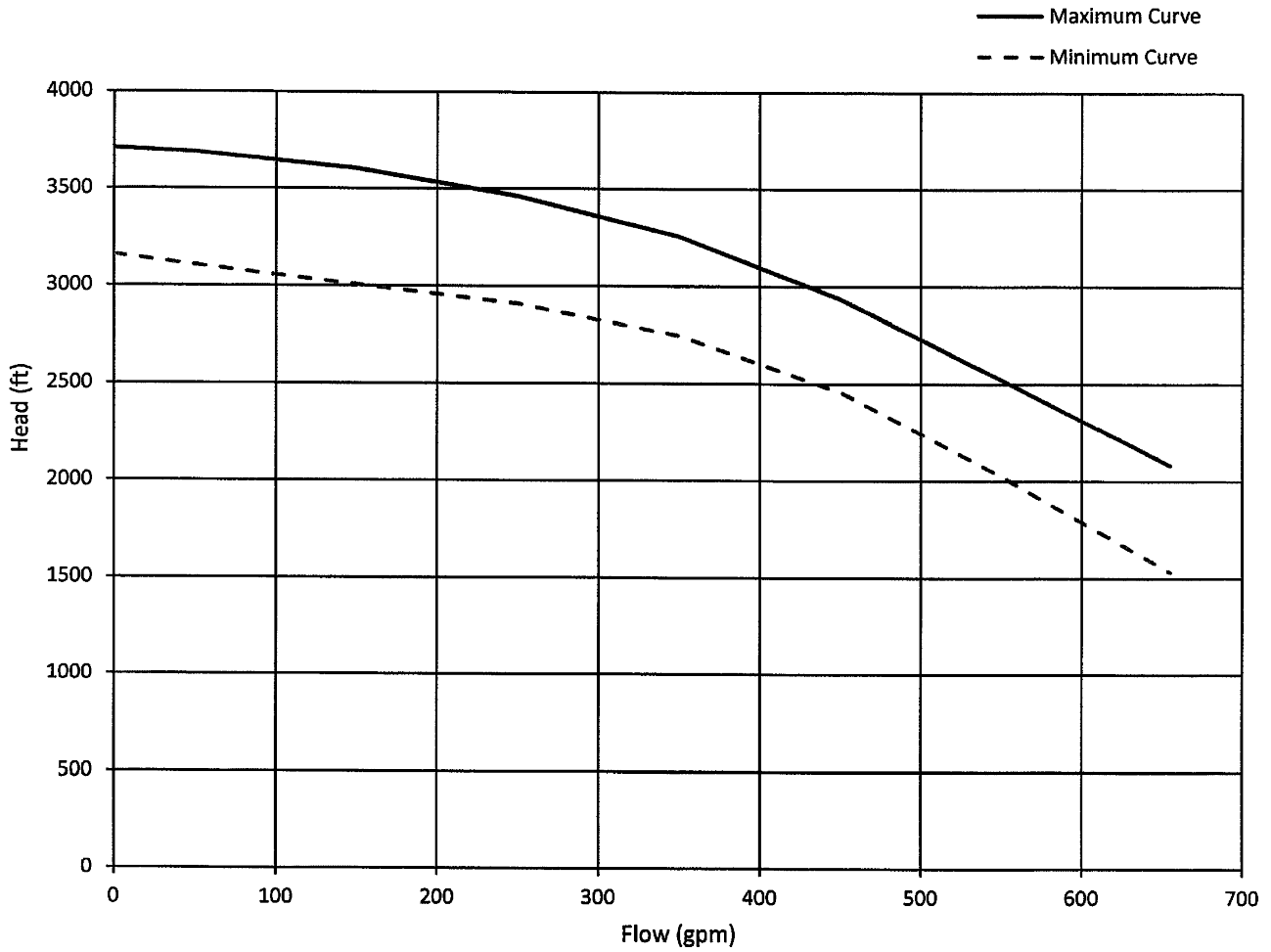

BYRON/BRAIDWOOD STATIONS
UPDATED FINAL SAFETY ANALYSIS REPORT

FIGURE 6.3-5
SAFETY INJECTION PUMP
PERFORMANCE CURVE
(WITHOUT UNCERTAINTY)

Figure 6.3-6 has been deleted intentionally.

Figure 6.3-7 has been deleted intentionally.

Figure 6.3-8 has been deleted intentionally.

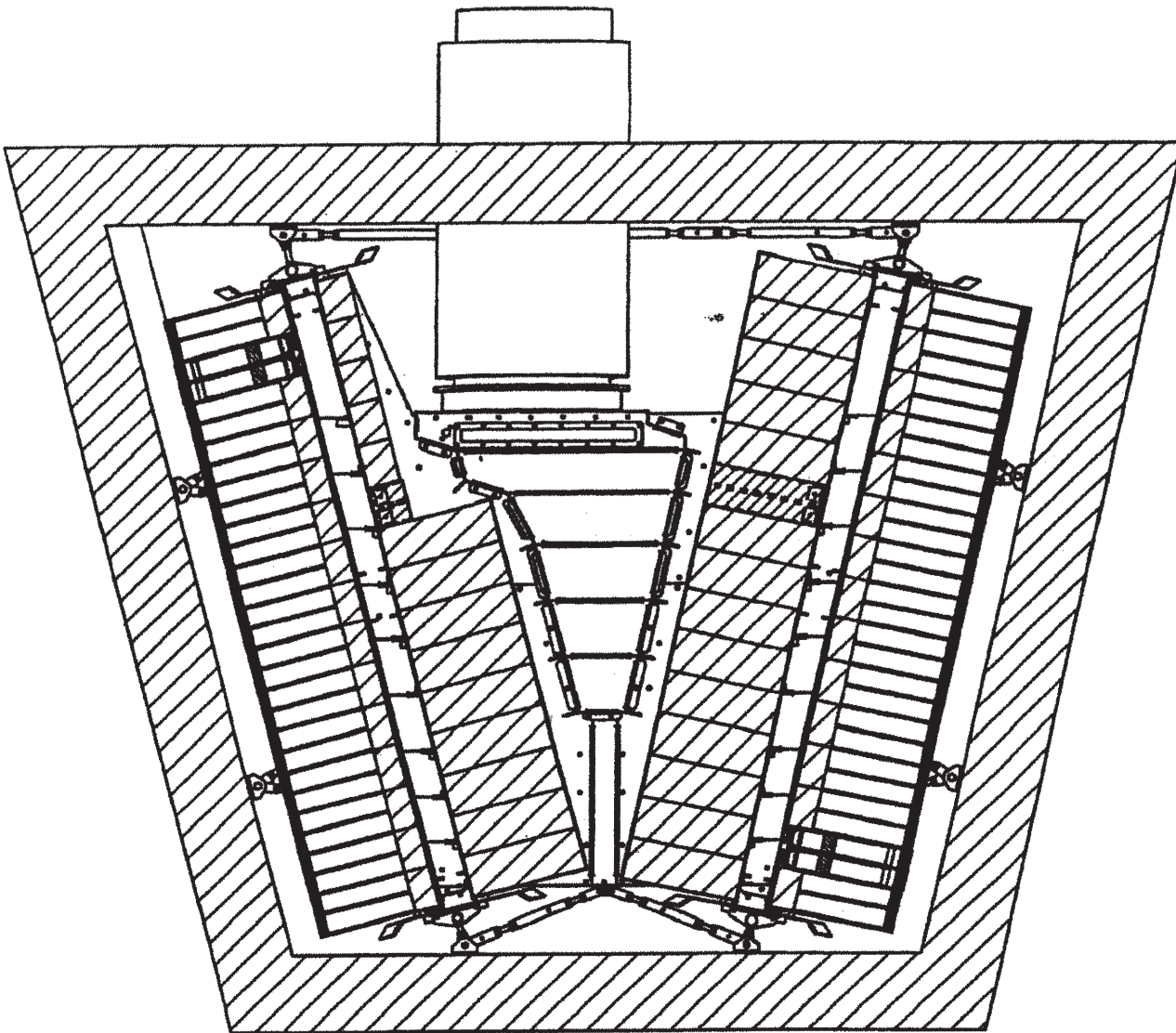

BYRON/BRAIDWOOD STATIONS
UPDATED FINAL SAFETY ANALYSIS REPORT

FIGURE 6.3-8A
RECIRCULATION SUMP DETAILS

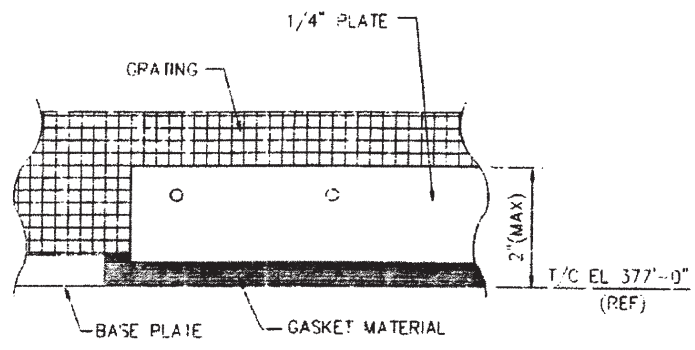
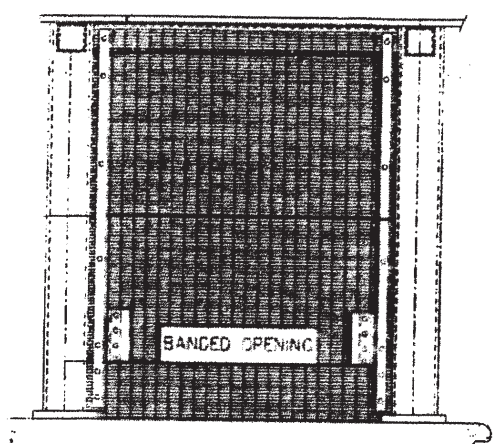
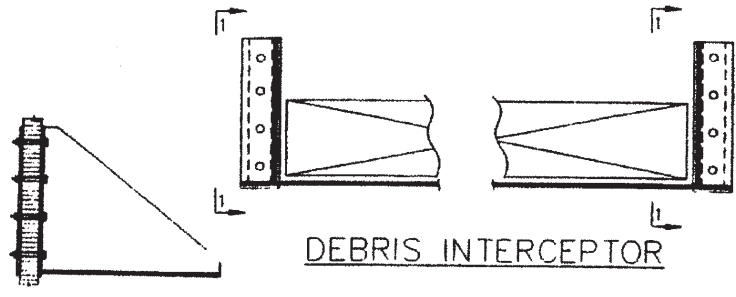
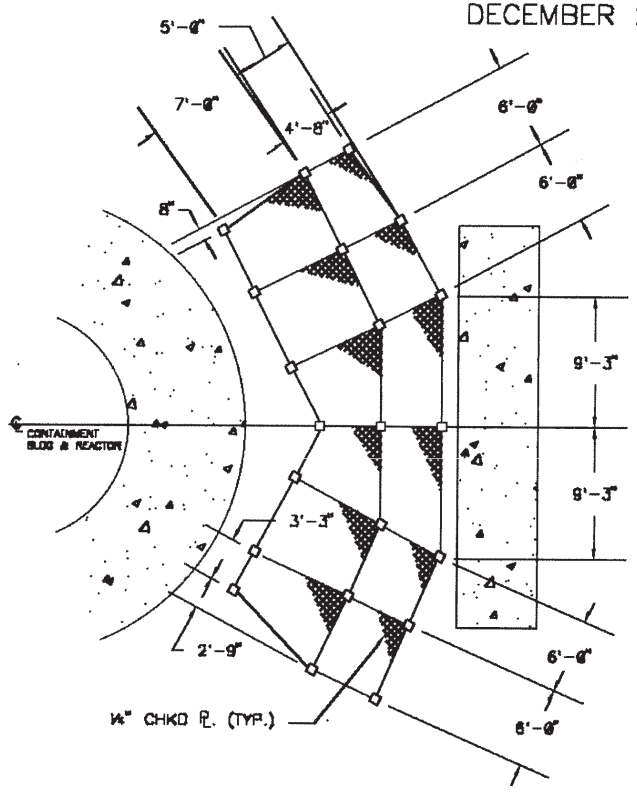
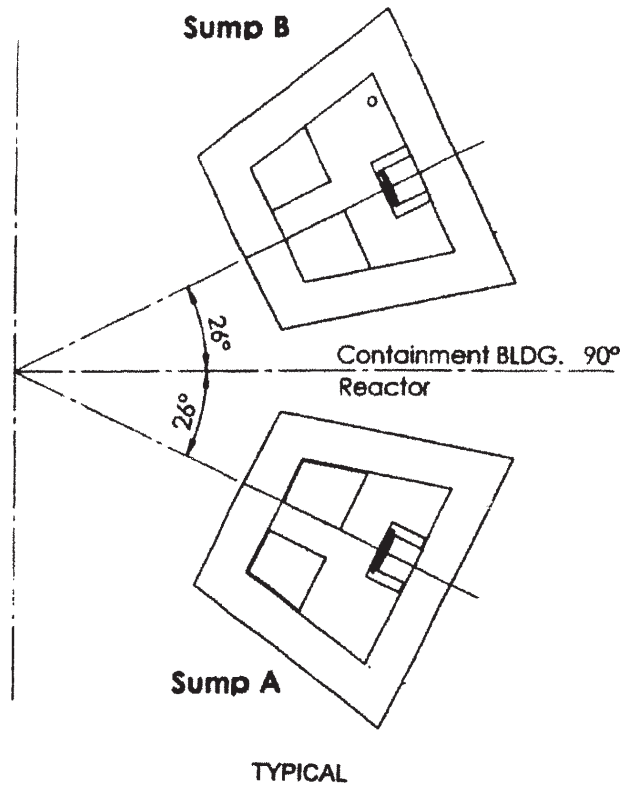

BYRON/BRAIDWOOD STATIONS
UPDATED FINAL SAFETY ANALYSIS REPORT

FIGURE 6.3-8B
SUMP OUTLINE/TRASH RACK DETAILS

Figure 6.4-1 has been deleted intentionally.

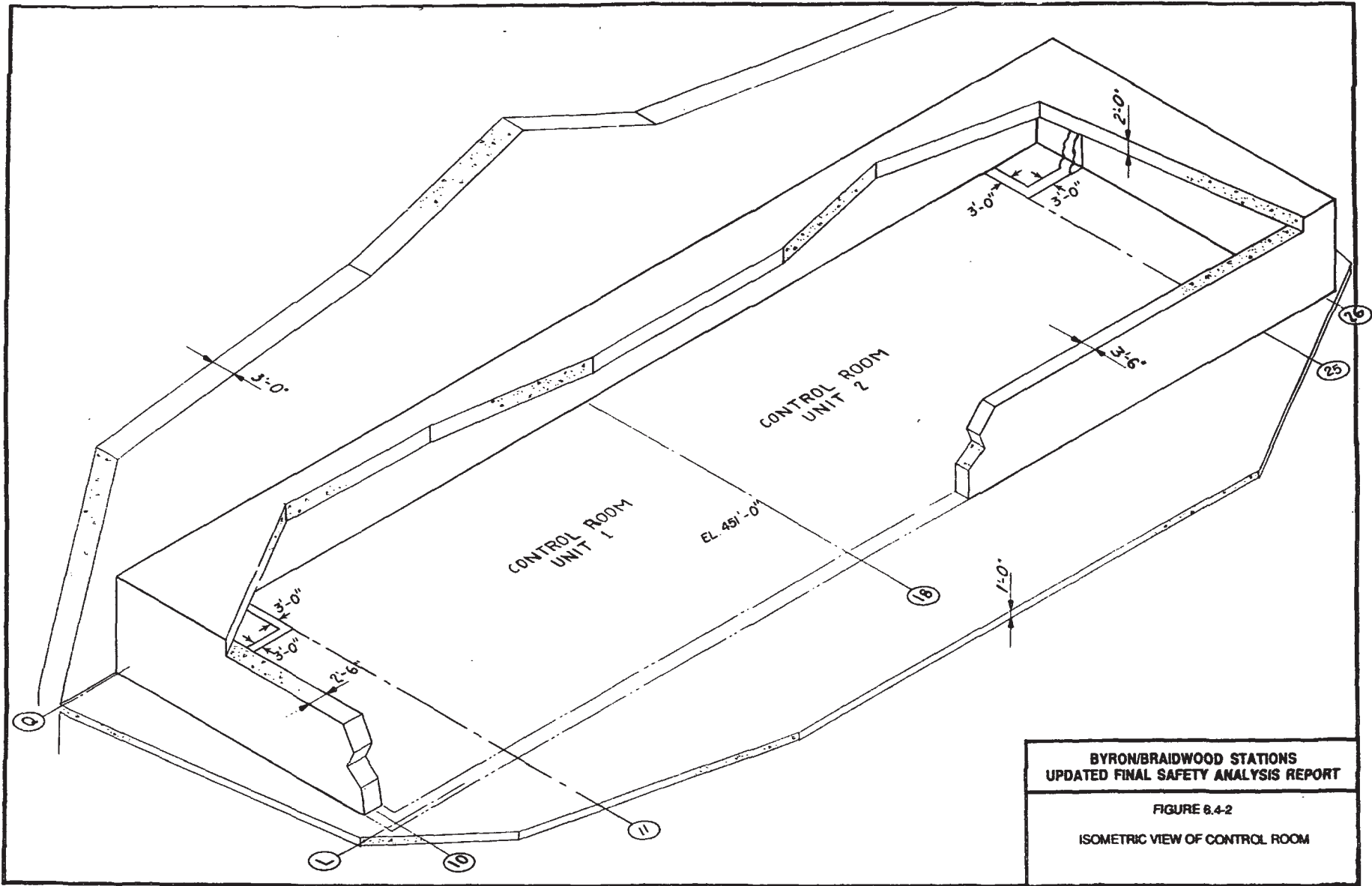

**BYRON/BRAIDWOOD STATIONS
 UPDATED FINAL SAFETY ANALYSIS REPORT**

FIGURE 8.4-2
 ISOMETRIC VIEW OF CONTROL ROOM

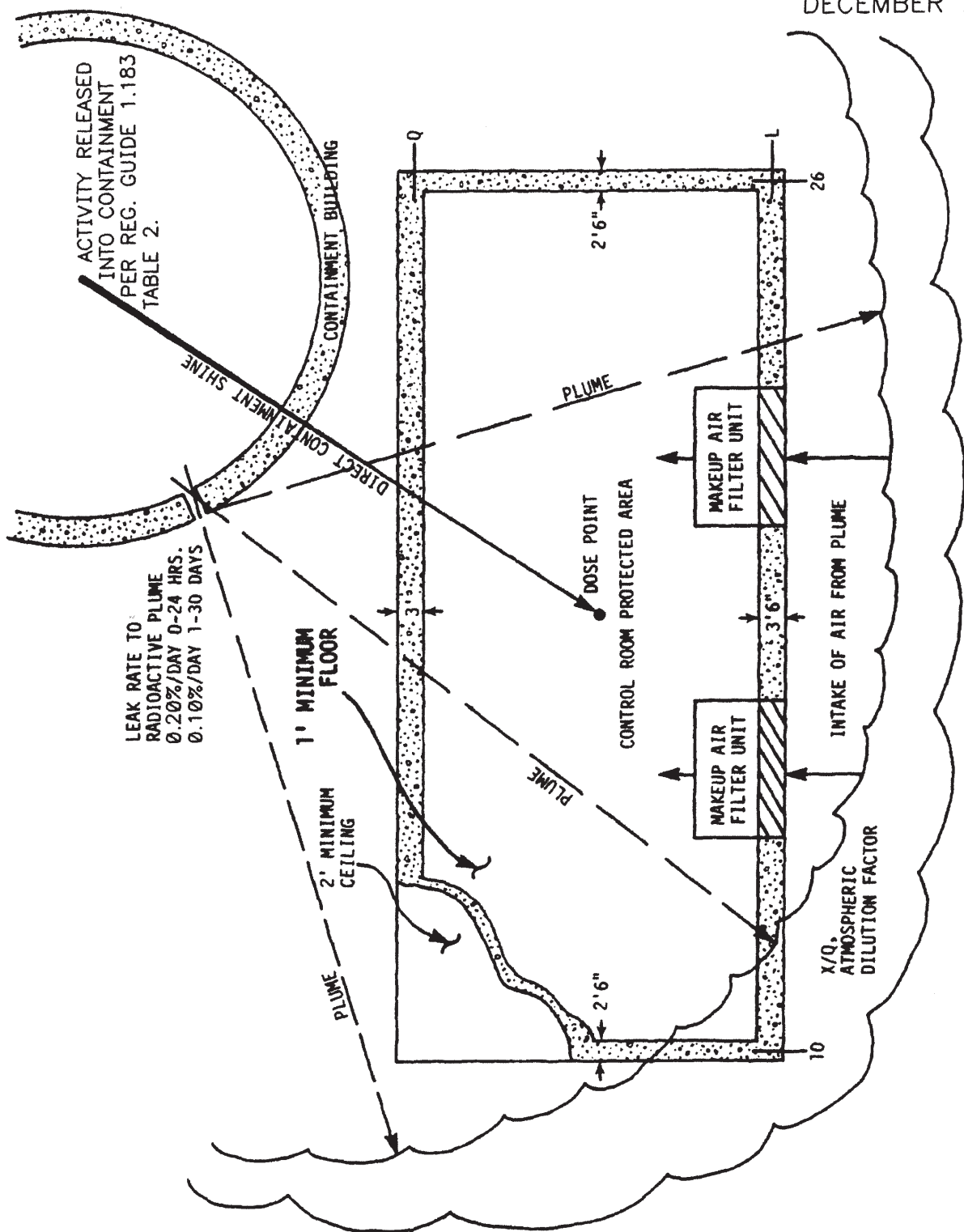

**BYRON/BRAIDWOOD STATIONS
UPDATED FINAL SAFETY ANALYSIS REPORT**

FIGURE 6.4-3

**DIAGRAMMATIC REPRESENTATION OF
RADIOACTIVE SOURCES FOR PROTECTED AREA
OF CONTROL ROOM DURING A LOCA**

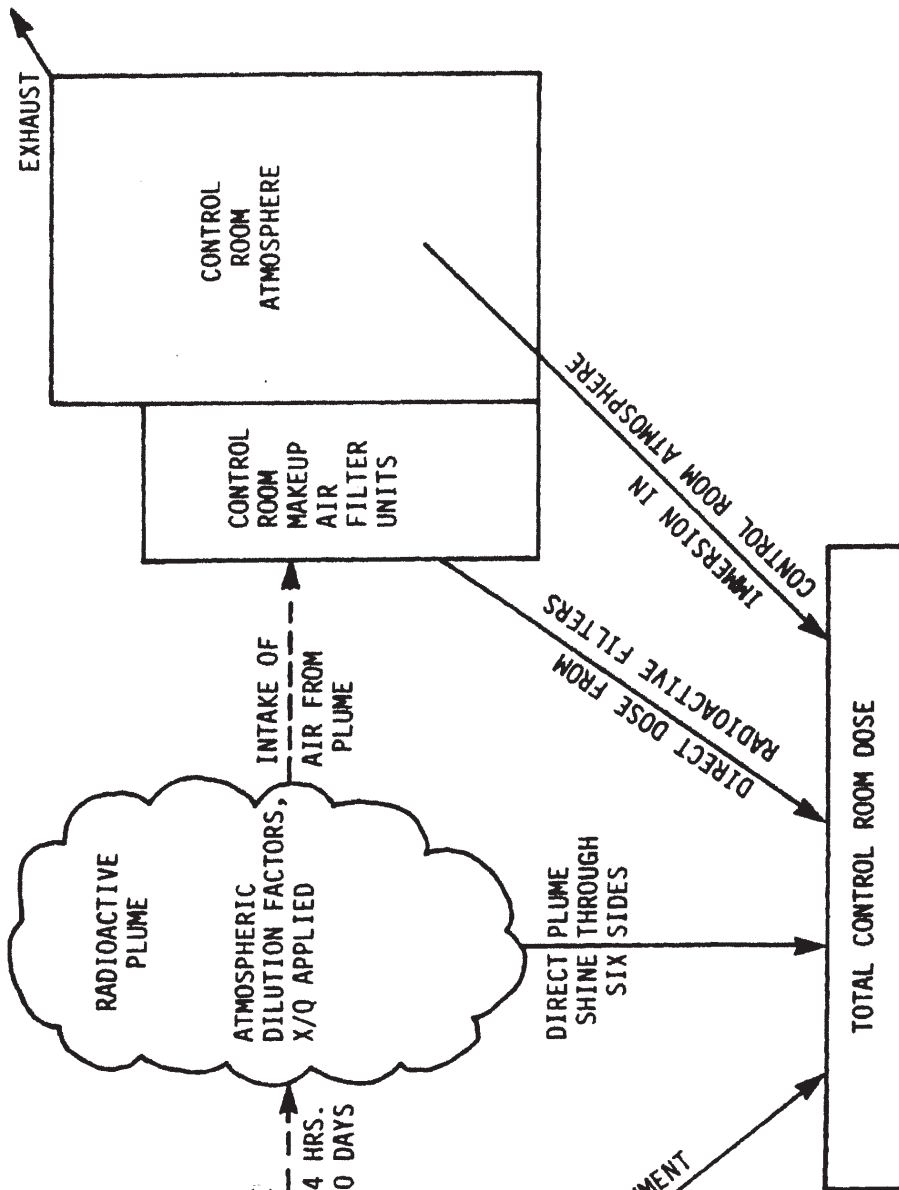

**BYRON/BRAIDWOOD STATIONS
UPDATED FINAL SAFETY ANALYSIS REPORT**

FIGURE 6.4-4

**DIAGRAMMATIC REPRESENTATION OF
TOTAL CONTROL ROOM LOCA DOSE**

Security - Related Information Figure Withheld Under 10 CFR 2.390

BYRON/BRAIDWOOD STATIONS UPDATED FINAL SAFETY ANALYSIS REPORT
FIGURE 6.4-5 SIMPLIFIED CONTROL ROOM HVAC SYSTEM DIAGRAM NORMAL OPERATION

Security - Related Information Figure Withheld Under 10 CFR 2.390

BYRON/BRAIDWOOD STATIONS UPDATED FINAL SAFETY ANALYSIS REPORT
FIGURE 6.4-6 SIMPLIFIED CONTROL ROOM HVAC SYSTEM DIAGRAM EMERGENCY OPERATION

Security - Related Information Figure Withheld Under 10 CFR 2.390

<p>BYRON/BRAIDWOOD STATIONS UPDATED FINAL SAFETY ANALYSIS REPORT</p>
<p>FIGURE 6.4-7 SIMPLIFIED CONTROL ROOM HVAC SYSTEM DIAGRAM EMERGENCY OPERATION (ALTERNATE)</p>

Security - Related Information Figure Withheld Under 10 CFR 2.390

BYRON STATION
UPDATED FINAL SAFETY ANALYSIS REPORT

FIGURE 6.4-8
SIMPLIFIED CONTROL ROOM
HVAC SYSTEM DIAGRAM
MAKEUP HEPA FILTER TESTING OPERATION

Figures 6.5-1 through 6.5-4 have been deleted intentionally.

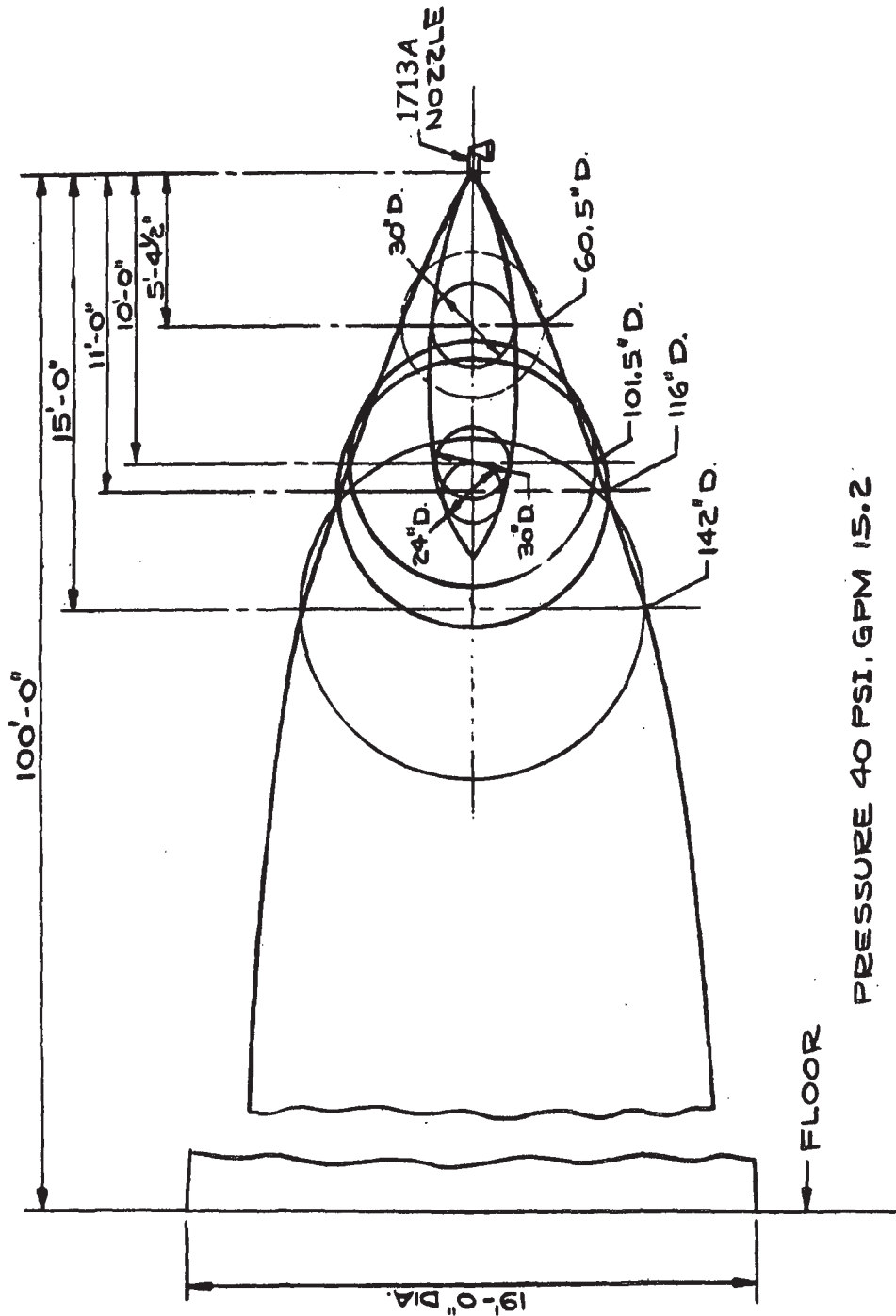

**BYRON/BRAIDWOOD STATIONS
UPDATED FINAL SAFETY ANALYSIS REPORT**

FIGURE 6.5-5

NOZZLE SPRAYING DOWNWARD

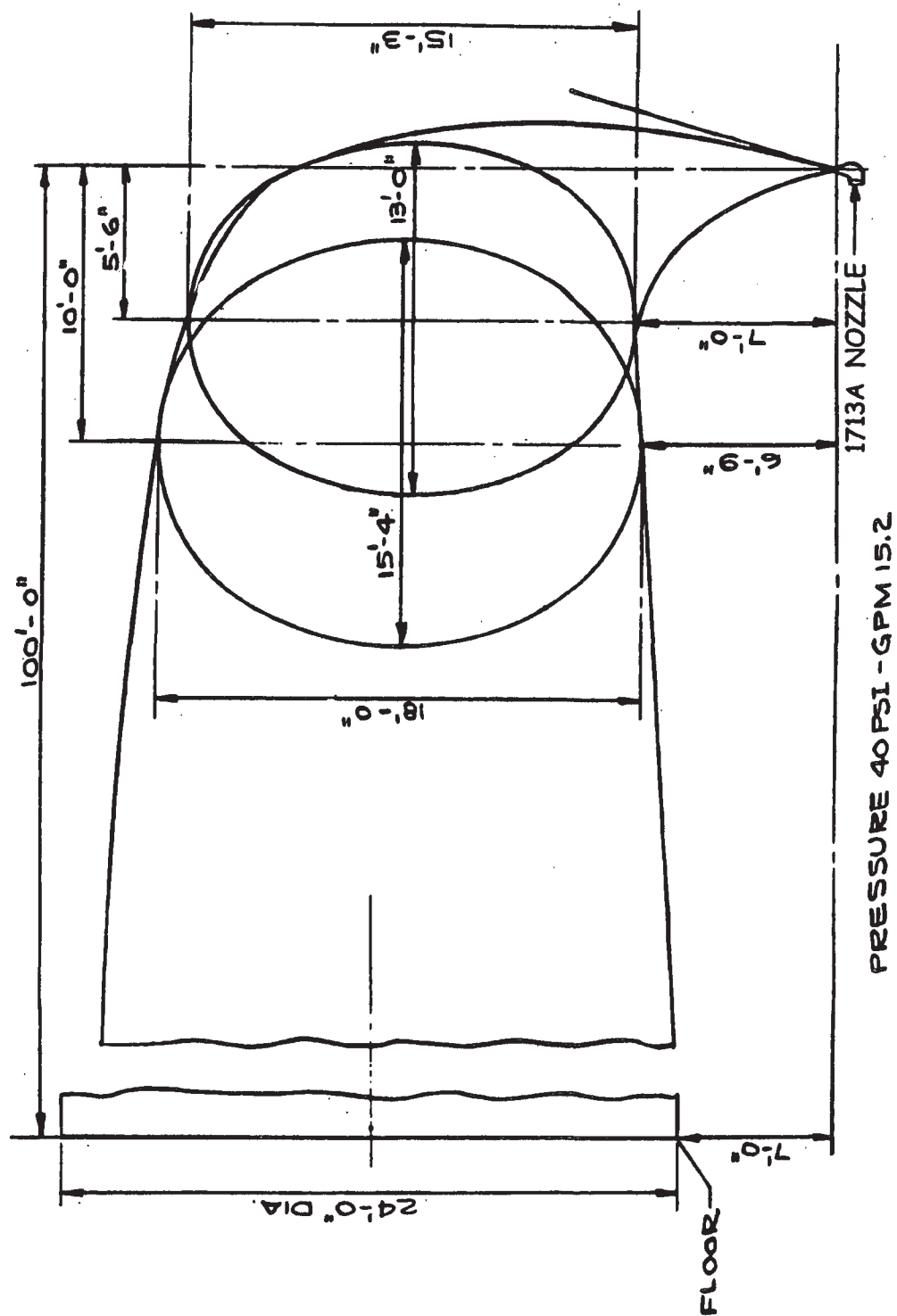

**BYRON/BRAIDWOOD STATIONS
UPDATED FINAL SAFETY ANALYSIS REPORT**

FIGURE 6.5-6

NOZZLE SPRAYING HORIZONTALLY

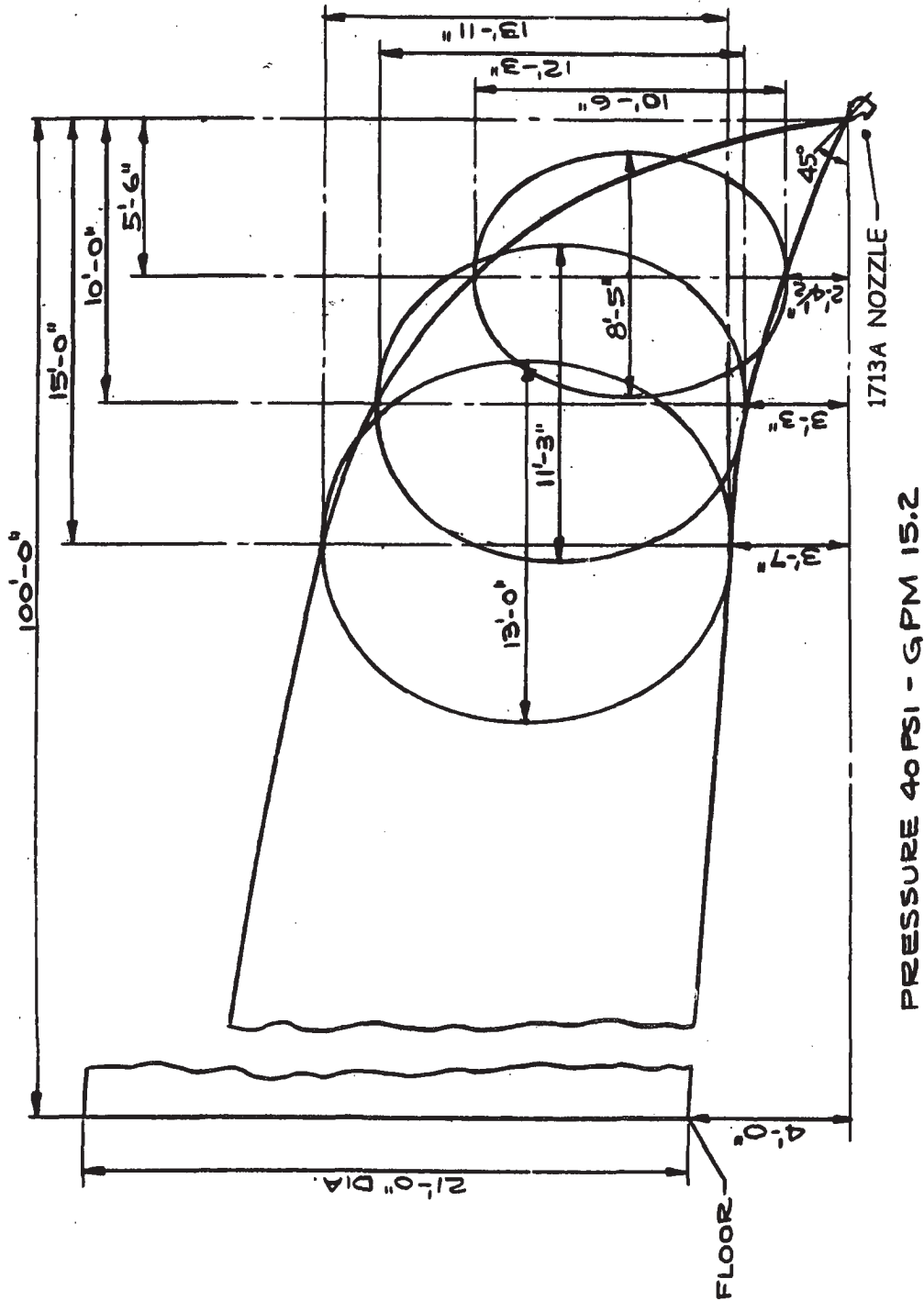

**BYRON/BRAIDWOOD STATIONS
UPDATED FINAL SAFETY ANALYSIS REPORT**

FIGURE 6.5-7

NOZZLE SPRAYING DOWNWARD AT 45°

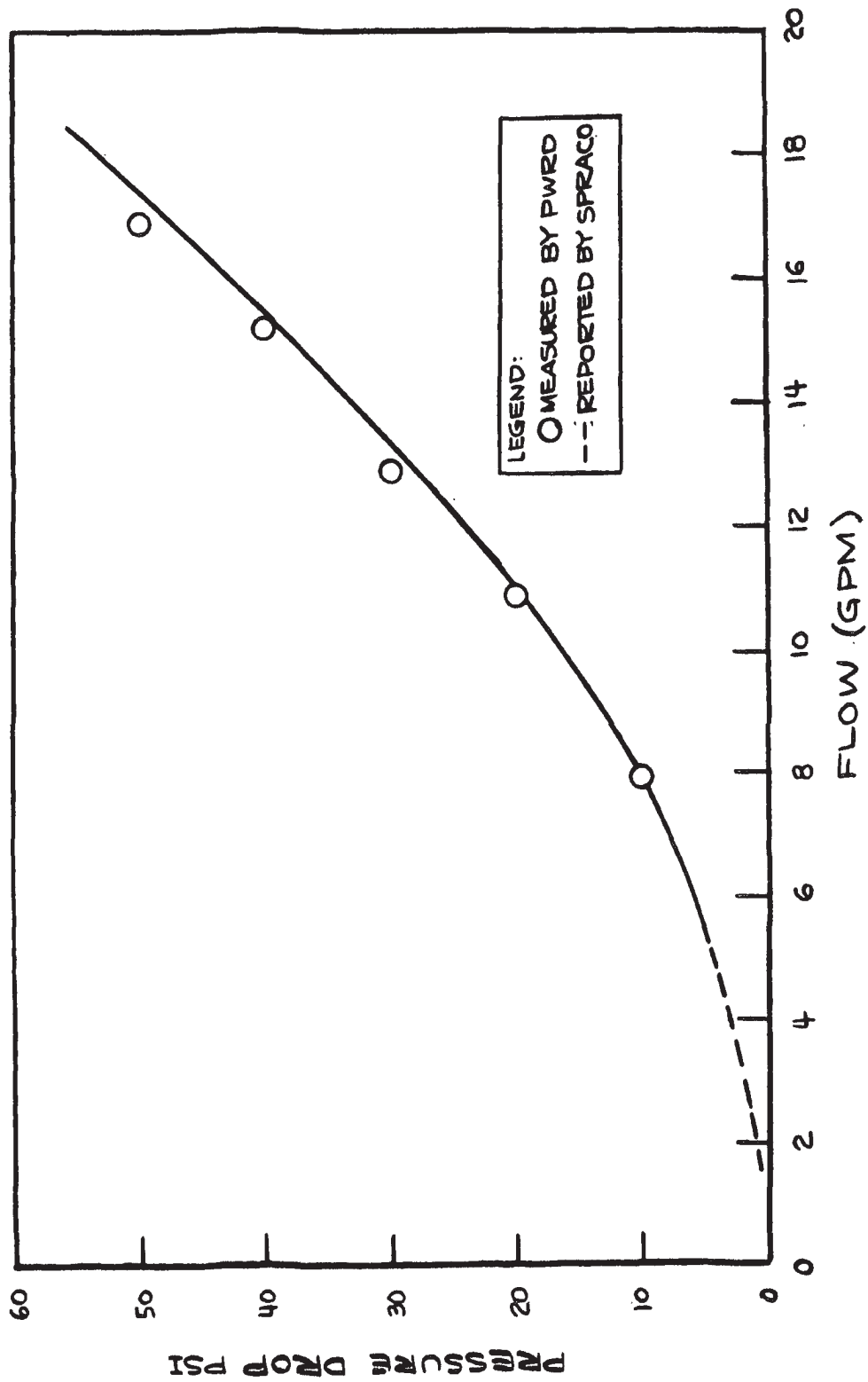

**BYRON/BRAIDWOOD STATIONS
UPDATED FINAL SAFETY ANALYSIS REPORT**

FIGURE 6.5-8

PRESSURE DROP VS. FLOW
1713A NOZZLE

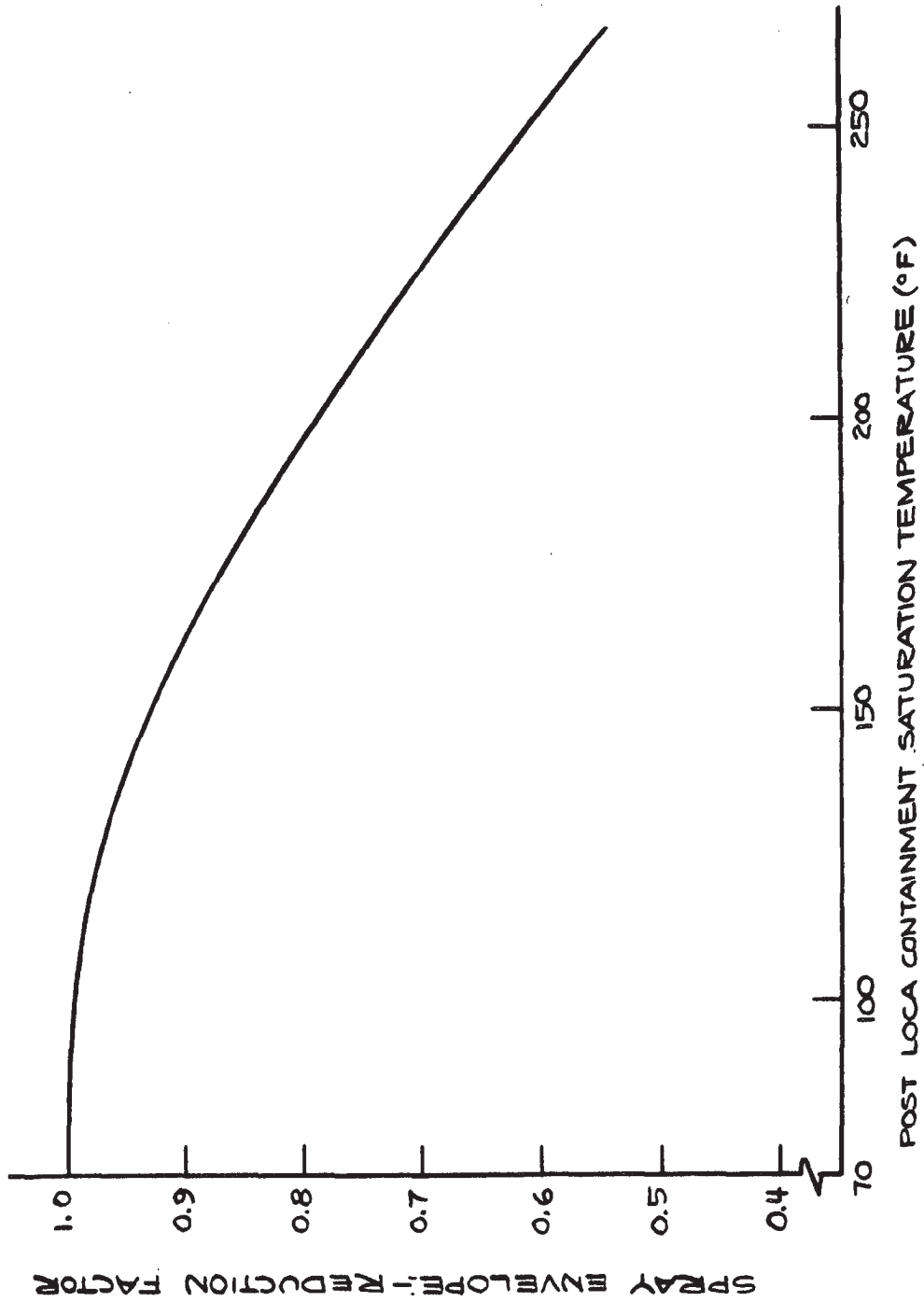

**BYRON/BRAIDWOOD STATION
 UPDATED FINAL SAFETY ANALYSIS REPORT**

**FIGURE 6.5-9
 SPRAY ENVELOPE REDUCTION FACTOR**