

**OFFICE OF CIVILIAN RADIOACTIVE WASTE MANAGEMENT  
DESIGN CALCULATION OR ANALYSIS COVER SHEET**

1. QA: QA  
2. Page 1

3. System: Waste Isolation System	4. Document Identifier: CAL-WIS-TH-000013 REV A	5. Verified: <input type="checkbox"/> Yes <input checked="" type="checkbox"/> No
6. Title: Thermal Calculation of the In-Drift Configuration Options		MOL.20020613.0482

7. Group:  
Analyses and Component Design - Specialty Analyses and Waste Package Design

8. Document Status Designation:  
 Preliminary   
 Final   
 Superseded   
 Cancelled

9. Notes/Comments:

Attachments	Total Number of Pages
I: Compact disk (CD) (1 of 1) containing ANSYS and Excel files	N/A
II: File listing for Attachment I	4

**RECORD OF REVISIONS**

10. No.	11. Reason for Revision	12. Total No. of Pages	13. Last Page No.	14. Originator (Print/Sign)	15. Checker (Print/Sign)	16. Quality Engineering Representative (Print/Sign)	17. Approved/ Accepted (Print/Sign)	18. Date
A	Initial Issue	69	II-4	HONGYAN MA <i>Hongyan</i>	Matthew Hinds <i>M.Hinds</i>	Daniel J. Tunney D. J. Tunney 5/30/2002	M.J. ANDERSON <i>M.J. Anderson</i>	5/30/02

---

**CONTENTS**

	Page
1. PURPOSE.....	5
2. METHOD.....	5
3. ASSUMPTIONS.....	5
4. USE OF COMPUTER SOFTWARE.....	7
5. CALCULATION.....	8
5.1 ALTERNATIVE IN-DRIFT CONFIGURATION EVALUATION.....	8
5.1.1 Alternative In-Drift Configuration Cases.....	8
5.1.2 ANSYS Thermal Representations.....	12
5.2 WASTE PACKAGE DIAMETER EFFECT.....	14
5.3 THERMAL PROPERTIES.....	15
5.4 ANSYS FILES.....	18
6. RESULTS.....	19
6.1 ALTERNATIVE IN-DRIFT CONFIGURATION TEMPERATURE RESULTS.....	19
6.2 IN-DRIFT THERMAL RESISTANCE.....	19
6.3 RESULTS OF DRIFT DIAMETER EFFECT.....	53
7. REFERENCES.....	63
8. ATTACHMENTS.....	65

Originator: HM Date: 5/29/02Checker: MH Date: 5/29/02

## FIGURES

	Page
5-1. Configuration for SR Base Design.....	9
5-2. Configuration for Cases (1) and (2).....	9
5-3. Configuration for Case (3).....	10
5-4. Configuration for Case (4).....	10
5-5. Configuration for Case (5).....	11
5-6. Configuration for Case (6).....	11
6-1. Waste Package Surface Temperature Comparison with SR Baseline Design ( $T_{5m}=20^{\circ}\text{C}$ ) ..	44
6-2. Drift Wall Temperature Comparison with SR Baseline Design ( $T_{5m}=20^{\circ}\text{C}$ ) ..	44
6-3. Waste Package Surface Temperature Comparison with SR Baseline Design ( $T_{5m}=30^{\circ}\text{C}$ ) ..	45
6-4. Drift Wall Temperature Comparison with SR Baseline Design ( $T_{5m}=30^{\circ}\text{C}$ ).....	45
6-5. Waste Package Surface Temperature Comparison with SR Baseline Design ( $T_{5m}=40^{\circ}\text{C}$ ) ..	46
6-6. Drift Wall Temperature Comparison with SR Baseline Design ( $T_{5m}=40^{\circ}\text{C}$ ) ..	46
6-7. Waste Package Surface Temperature Comparison with SR Baseline Design ( $T_{5m}=50^{\circ}\text{C}$ ) ..	47
6-8. Drift Wall Temperature Comparison with SR Baseline Design ( $T_{5m}=50^{\circ}\text{C}$ ) ..	47
6-9. Waste Package Surface Temperature Comparison with SR Baseline Design ( $T_{5m}=60^{\circ}\text{C}$ ) ..	48
6-10. Drift Wall Temperature Comparison with SR Baseline Design ( $T_{5m}=60^{\circ}\text{C}$ ) ..	48
6-11. Waste Package Surface Temperature Comparison with SR Baseline Design ( $T_{5m}=70^{\circ}\text{C}$ ) ..	49
6-12. Drift Wall Temperature Comparison with SR Baseline Design ( $T_{5m}=70^{\circ}\text{C}$ ) ..	49
6-13. Waste Package Surface Temperature Comparison with SR Baseline Design ( $T_{5m}=80^{\circ}\text{C}$ ) ..	50
6-14. Drift Wall Temperature Comparison with SR Baseline Design ( $T_{5m}=80^{\circ}\text{C}$ ) ..	50
6-15. Waste Package Surface Temperature Comparison with SR Baseline Design ( $T_{5m}=90^{\circ}\text{C}$ ) ..	51
6-16. Drift Wall Temperature Comparison with SR Baseline Design ( $T_{5m}=90^{\circ}\text{C}$ ) ..	51
6-17. Temperature Contours ( $T_{5m} = 70^{\circ}\text{C}$ ) ..	52
6-18. Waste Package Surface Temperature Comparison ( $T_{\text{drift}} = 20^{\circ}\text{C}$ ) ..	58
6-19. Waste Package Surface Temperature Comparison ( $T_{\text{drift}} = 30^{\circ}\text{C}$ ) ..	58
6-20. Waste Package Surface Temperature Comparison ( $T_{\text{drift}} = 40^{\circ}\text{C}$ ) ..	59
6-21. Waste Package Surface Temperature Comparison ( $T_{\text{drift}} = 50^{\circ}\text{C}$ ) ..	59
6-22. Waste Package Surface Temperature Comparison ( $T_{\text{drift}} = 60^{\circ}\text{C}$ ) ..	60
6-23. Waste Package Surface Temperature Comparison ( $T_{\text{drift}} = 70^{\circ}\text{C}$ ) ..	60
6-24. Waste Package Surface Temperature Comparison ( $T_{\text{drift}} = 80^{\circ}\text{C}$ ) ..	61
6-25. Waste Package Surface Temperature Comparison ( $T_{\text{drift}} = 90^{\circ}\text{C}$ ) ..	61
6-26. Waste Package Surface Temperature Comparison ( $T_{\text{drift}} = 200^{\circ}\text{C}$ ) ..	62

Originator: HM Date: 5/29/02Checker: MH Date: 5/29/02

## TABLES

	Page
5-1. Case Summary.....	13
5-2. Key Dimensions Used in the Calculation.....	14
5-3. Material List .....	15
5-4. Thermal Properties of the Drift Rock.....	15
5-5. Effective Thermal Conductivity of the Waste Package Internal Cylinder .....	16
5-6. Thermal Conductivity of Alloy 22 .....	16
5-7. Thermal Conductivity of 316NG.....	16
5-8. Emissivity of Alloy 22.....	17
5-9. Emissivity of Titanium Grade 7 .....	17
5-10. Thermal Conductivity of Titanium Grade 7.....	17
5-11. Effective Thermal Conductivity of the Invert (top layer).....	18
5-12. Thermal Properties of Invert Ballast Material (bottom layer).....	18
6-1. Temperature Results for SR Baseline Case (D = 5.5 m; circular; with drip shield) .....	20
6-2. Temperature Results for SR Baseline Case (D = 5.5 m; circular; without drip shield) .....	23
6-3. Temperature Results for Case 1 (D = 4.5 m; circular; trench; ground support).....	26
6-4. Temperature Results for Case 2 (D = 5.5 m; circular; trench; ground support).....	29
6-5. Temperature Results for Case 3 (D = 6.0 m; circular) .....	32
6-6. Temperature Results for Case 4 (D = 6.0 m; circular; trench) .....	35
6-7. Temperature Results for Case 5 (D = 5.0 m; mailbox) .....	38
6-8. Temperature Results for Case 6 (D = 4.0 m; mailbox; no drip shield) .....	41
6-9. Waste Package Surface Temperature Comparison (D = 1 m vs. D = 1.564 m).....	54
6-10. Waste Package Surface Temperature Comparison (D = 1.5 m vs. D = 1.564 m).....	55
6-11. Waste Package Surface Temperature Comparison (D = 2 m vs. D = 1.564 m).....	56
6-12. Waste Package Surface Temperature Comparison (D = 2.5 m vs. D = 1.564 m).....	57
8-1. Attachments Summary .....	65

Originator: HM Date: 5/29/02Checker: MM Date: 5/29/02

## 1. PURPOSE

The objective of this calculation is to evaluate the impact of the in-drift configuration on the waste package thermal performance. The scope of this calculation is limited to thermal calculation of the alternative in-drift configuration options and comparison against the Site Recommendation (SR) baseline in-drift configuration. This calculation is performed to support the Design Alternatives Study for Licensing Application (LA). The procedure, AP-3.12Q, *Design Calculations and Analyses* (Ref. 1) and *Technical Work Plan for: Waste Package Design Description for LA* (Ref. 2), work package P3212234FC – *WP Design Concept Re-Evaluation LA* are used to develop this document. The Activity Evaluation (Addendum A, Ref. 2) determined that the preparation of this document is subject to the Quality Assurance Requirement Description Requirements (Ref. 21). The information provided in References 19 and 23 is that of the potential design of the type of waste package and drip shield considered in this calculation, and all obtained results are valid for these designs only.

## 2. METHOD

Finite element solution is performed using the commercially available ANSYS Version (V) 5.4 finite element code (Ref. 7) and ANSYS V5.6.2 finite element code (Ref. 13). Two-dimensional (2-D) finite element representations of the waste package emplacement are developed and analyzed parametrically using the steady-state ANSYS solvers.

The control of the electronic management of information was evaluated in accordance with the planned method specified in the technical work plan (Ref. 2). This evaluation determined that current work processes and procedures are adequate for the control of the electronic management of information for this activity.

## 3. ASSUMPTIONS

- 3.1 The waste package emplaced in the drift is simulated as a homogeneous inner cylinder with inner and outer shells. The rationale for this assumption is that since the waste package internal temperatures are not of interest for this calculation, smeared material properties for the homogeneous cylinder are applied in the ANSYS representations (see Section 5.3). This assumption is used in Sections 5.1 and 5.3.
- 3.2 The ballast material used in the invert and conduit ground support is assumed to have a thermal conductivity of 0.2 W/m-K. The rationale for selecting this value is that based on the experimental measurements on possible ballast materials (i.e., crushed tuff, overton sand, silica sand, and white marble), the measured values range from 0.13 to 0.35 W/m-K (Ref. 10). Therefore, 0.2 W/m-K is selected for this calculation. This assumption is used in Section 5.3.
- 3.3 The waste package supports are not included in the ANSYS representations. The rationale for this assumption is that the waste package supports have point contact with the waste package in only a few places. Therefore, conduction through the support

Originator: HM Date: 5/29/02

Checker: MH Date: 5/29/02

structure will be limited and can be conservatively neglected. This assumption is used in Section 5.1.

- 3.4 The natural convection in the drift is ignored for the calculation. The rationale for this assumption is that since the emplacement drifts are not actively ventilated in the post-closure period, natural convection in the drift is conservatively ignored. Therefore, radiation is the dominant heat transfer mechanism for this calculation. This assumption is used in Section 5.1.
- 3.5 The thermal conductivity of the repository rock ( $T_{ptll}$ ) is taken from Ref. 8 (DTN: SN0003T0571897.013). The rationale for this assumption is that although Ref. 8 is superseded by Ref. 22 (DTN: SN0011T0571897.014), the thermal conductivity provided in Ref. 22 is based on lithophysal porosity of zero which is not reasonable for this calculation. Therefore, Ref. 8 is used as the best available source for the thermal conductivity values. This assumption is used in Section 5.3.

Originator: HM Date: 5/29/02

Checker: MH Date: 5/29/02

#### 4. USE OF COMPUTER SOFTWARE

The finite element computer code used for this calculation is ANSYS V5.4 (Ref. 7), which is identified by the Computer System Configuration Item (CSCI) identifier 30040 V5.4. ANSYS V5.4 is a qualified commercially available finite element code and is appropriate for the thermal analysis of the waste package as performed in this calculation. Calculations using the ANSYS V5.4 software were executed on a Hewlett-Packard (HP) 9000 Series, operation system HP.UX10.20 (Central Processing Unit Name: "Bloom" and Civilian Radioactive Waste Management System - Management and Operating Contractor [CRWMS-M&O] Tag Number: 700887). The ANSYS V5.4 evaluations performed in this calculation are fully within the range of the validation performed for ANSYS V5.4. Access to, and use of, the code for this calculation was granted by Software Configuration in accordance with the appropriate procedures. Inputs to ANSYS V5.4 and output files are included as attachments and are described in Section 5 of this document.

The finite element computer code also used for this calculation is ANSYS V5.6.2 (Ref. 13), which is identified by the Software Tracking number 10364-5.6.2-00. ANSYS V5.6.2 is a qualified commercially available finite element code and is appropriate for the thermal analysis of the waste package as performed in this calculation. Calculations using the ANSYS V5.6.2 software were executed on a Hewlett-Packard (HP) 9000 Series, operation system HP.UX10.20 (Central Processing Unit Name: "Bloom" and Civilian Radioactive Waste Management System - Management and Operating Contractor [CRWMS-M&O] Tag Number: 700887). The ANSYS V5.6.2 evaluations performed in this calculation are fully within the range of the validation performed for ANSYS V5.6.2. Access to, and use of, the code for this calculation was granted by Software Configuration in accordance with the appropriate procedures. Inputs to ANSYS V5.6.2 and output files are included as attachments and are described in Section 5 of this document.

Commercially available software Excel 97, which is exempt from requirements of AP-SI.1Q (Ref. 6), is used for the curve fit and waste package diameter effect calculations in Section 5 and used for plotting results in Section 6. The calculation results can be reproduced and checked by hand.

Originator: HM Date: 5/29/02

Checker: MH Date: 5/29/02

## 5. CALCULATION

### 5.1 ALTERNATIVE IN-DRIFT CONFIGURATION EVALUATION

#### 5.1.1 Alternative In-Drift Configuration Cases

Among all the alternative configurations considered in Reference 5, Attachment I, six representative geometries are selected for the thermal calculation. The SR baseline design (see Ref. 5, Attachment I) is also included for comparison purposes. The following lists the brief description of the SR base case, and changes made for the alternative in-drift configurations. Note that all the dimensions shown in Figures 5-1 through 5-6 are in mm or otherwise noted.

SR Baseline Case (see Figure 5-1, taken from p. I-4, Ref. 5):

The drift diameter is 5.5 m. Invert is constructed with steel beams / ballast material on the top layer and ballast material on the bottom layer. The material of the drip shield is titanium.

Cases (1) and (2) (see Figure 5-2):

This design alternative is not described in detail in Ref. 5 (The general concept can be found on p. 50, Ref. 5.). Figure 5-2 is used to illustrate the concept of the design. For the thermal calculation performed in this document, the ground control conduit is titanium and filled with ballast material. The thickness of the conduit is 150 mm. The trench is ballast material and lined with Alloy 22. Drift invert height of 308.4 mm instead of 465 mm is used in the calculation. The drift diameter for Case 1 is 4.5 m and 5.5 m for Case 2 (ignore 4.6 m drift diameter and 4.3 m diameter of ground support envelope in Figure 5-2). No drip shield is used.

Case (3) (see Figure 5-3, taken from p. I-6, Ref. 5):

The materials and geometry used in this representation are the same as in the SR baseline case, except that the drift diameter is increased from 5.5 m to 6.0 m due to the change in emplacement method.

Case (4) (see Figure 5-4, taken from p. I-8, Ref. 5):

The trench is ballast material with Alloy 22 liner. The height of the trench is 1041 mm instead of 1000 mm. The drift diameter is 6.0 m.

Case (5) (see Figure 5-5):

The width of the mailbox-shaped drift is 5.0 m.

Case (6) (see Figure 5-6):

The width of the mailbox-shaped drift is 4.0 m. The waste package is positioned higher due to different support design. No drip shield is used.

Originator: HM Date: 5/29/02

Checker: MH Date: 5/29/02



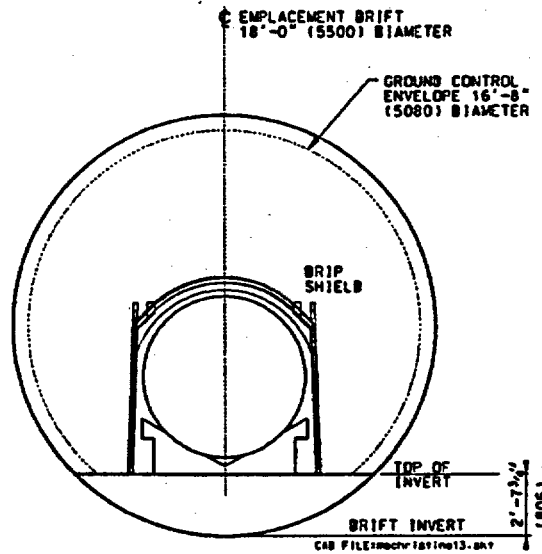

Figure 5-1. Configuration for SR Base Design

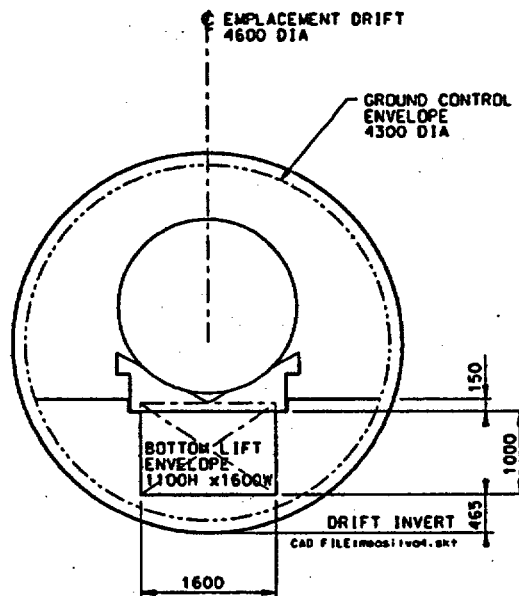

Figure 5-2. Configuration for Cases (1) and (2)

Originator: Hm Date: 5/29/02

Checker: MH Date: 5/29/02

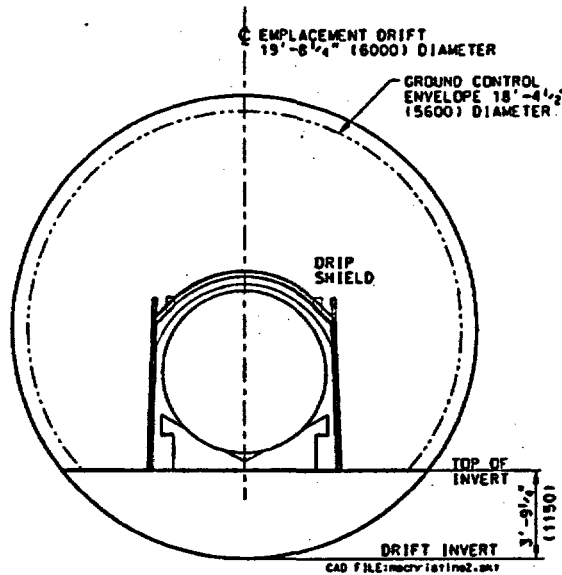

Figure 5-3. Configuration for Case (3)

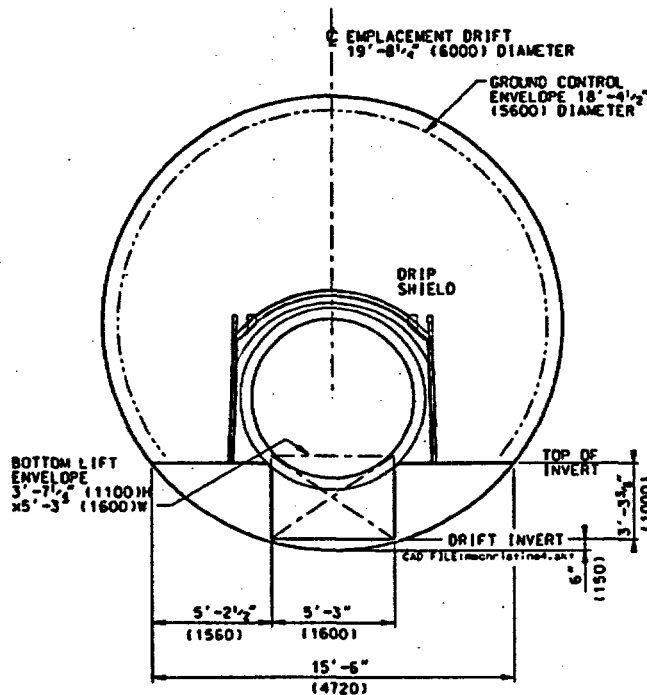

Figure 5-4. Configuration for Case (4)

Originator: HM Date: 5/29/02

Checker: MH Date: 5/29/02

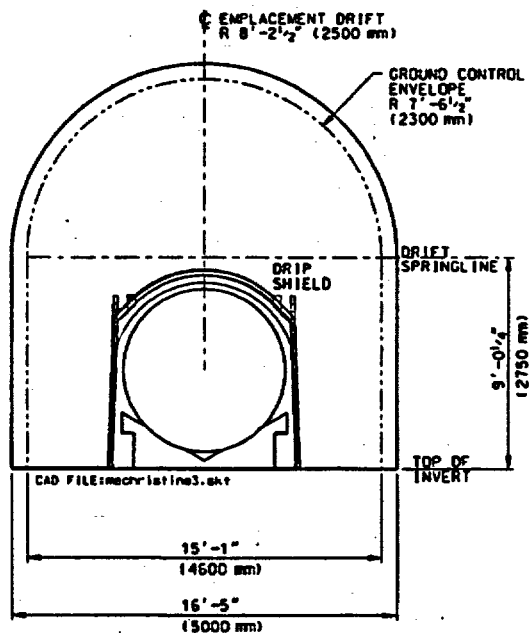

Figure 5-5. Configuration for Case (5)

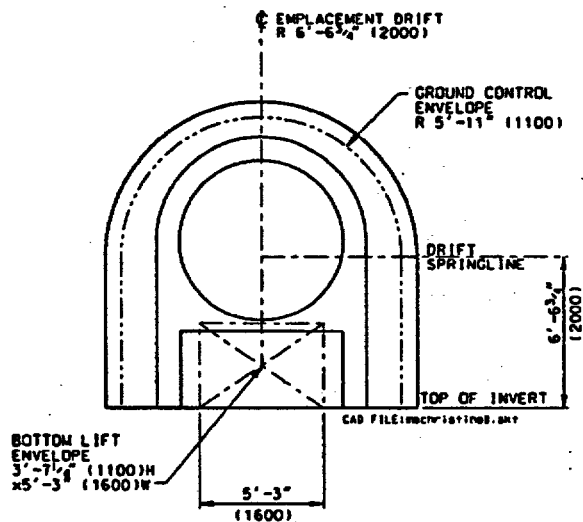

Figure 5-6. Configuration for Case (6)

Originator: HM Date: 5/29/02

Checker: MM Date: 5/29/02

### 5.1.2 ANSYS Thermal Representations

To evaluate the impact of in-drift configuration on the waste package thermal performance, a 2-D section includes a waste package, a drip shield (for most in-drift configurations), and a rock layer with outer diameter of 15.5 m (which is equivalent to 5 m into the rock from the drift wall for the SR base design; hereinafter referred to as 5m-into-rock). Since the temperature response at 5m-into-rock should remain the same for the same waste package heat generation rate regardless of the in-drift configuration, the same temperature boundary conditions at 5m-into-rock and same heat generation are used to compare the waste package and drift wall responses. The waste package supports are not represented in the drift, so that the conduction paths through the waste package supports are neglected (see Assumption 3.3). Only radiation and conduction heat transfer mechanisms are considered for the calculation (see Assumption 3.4).

The boundary condition for each of the cases is a constant temperature at the 5m-into-rock, the range of which includes 5°C, and 20 °C to 90°C in increments of 10°C (Only the SR Baseline cases with and without drip shield includes the 5°C rock boundary condition. Other cases range from 20°C to 90°C for the 5m-into-rock temperature.). Constant heat generation rates ranging from 0.01 kW/m to 1.44 kW/m from the waste package are also applied. A number of runs have been performed to account for various heat generation rates and temperature boundary conditions. For all the cases analyzed, the waste package is represented as a homogeneous cylinder with waste package shells (see Assumption 3.1). The temperature results from different cases will be compared with the SR baseline case. Table 5-1 lists the cases performed in this calculation.

In addition, the in-drift thermal resistance for the SR Baseline Case (Note: with and without drip shield cases are both included) and Case 2 (5.5 m ground control conduit) will be calculated. These correlations for thermal resistance can be later used for quick waste package surface temperature calculation if the drift wall temperature and thermal output are known. The thermal resistance is defined as

$$R = \frac{T_{wp} - T_{df}}{q} \quad (\text{Equation 5-1})$$

where:

R = thermal resistance between waste package surface and drift wall (°C·m/kW)

$T_{wp}$  = waste package surface temperature (°C)

$T_{df}$  = drift wall temperature (°C)

q = waste package heat generation (kW/m)

The thermal resistance R is curve-fit using a third-order polynomial correlation with respect to median temperature  $T_m = (T_{wp} + T_{df})/2$ . The correlation can then be expressed as

$$R = a + bT_m + cT_m^2 + dT_m^3 \quad (\text{Equation 5-2})$$

Originator: HM Date: 5/29/02

Checker: MH Date: 5/29/02

Attachment I shows the calculation details for the SR Baseline Case (with and without drip shield; files /Excel\_Files/d55\_cir\_fit.xls and /Excel\_Files/d55\_cir\_nodrip\_fit.xls) and Case 2 (file /Excel\_Files/d55\_trh\_gs\_fit.xls).

Table 5-1. Case Summary

SR Baseline Case (with drip shield)	SR Baseline Case (without drip shield)	Case 1	Case 2	Case 3	Case 4	Case 5	Case 6
/SR dp/	/SR nd/	/case1/	/case2/	/case3/	/case4/	/case5/	/case6/
d55 001	d55 001	d45 001	d55 001	d60 001	d60 001	d50 001	d40 001
d55 004	d55 004	d45 004	d55 004	d60 004	d60 004	d50 004	d40 004
d55 008	d55 008	d45 008	d55 008	d60 008	d60 008	d50 008	d40 008
d55 012	d55 012	d45 012	d55 012	d60 012	d60 012	d50 012	d40 012
d55 016	d55 016	d45 016	d55 016	d60 016	d60 016	d50 016	d40 016
d55 020	d55 020	d45 020	d55 020	d60 020	d60 020	d50 020	d40 020
d55 024	d55 024	d45 024	d55 024	d60 024	d60 024	d50 024	d40 024
d55 028	d55 028	d45 028	d55 028	d60 028	d60 028	d50 028	d40 028
d55 032	d55 032	d45 032	d55 032	d60 032	d60 032	d50 032	d40 032
d55 036	d55 036	d45 036	d55 036	d60 036	d60 036	d50 036	d40 036
d55 040	d55 040	d45 040	d55 040	d60 040	d60 040	d50 040	d40 040
d55 044	d55 044	d45 044	d55 044	d60 044	d60 044	d50 044	d40 044
d55 048	d55 048	d45 048	d55 048	d60 048	d60 048	d50 048	d40 048
d55 052	d55 052	d45 052	d55 052	d60 052	d60 052	d50 052	d40 052
d55 056	d55 056	d45 056	d55 056	d60 056	d60 056	d50 056	d40 056
d55 060	d55 060	d45 060	d55 060	d60 060	d60 060	d50 060	d40 060
d55 064	d55 064	d45 064	d55 064	d60 064	d60 064	d50 064	d40 064
d55 068	d55 068	d45 068	d55 068	d60 068	d60 068	d50 068	d40 068
d55 072	d55 072	d45 072	d55 072	d60 072	d60 072	d50 072	d40 072
d55 076	d55 076	d45 076	d55 076	d60 076	d60 076	d50 076	d40 076
d55 080	d55 080	d45 080	d55 080	d60 080	d60 080	d50 080	d40 080
d55 084	d55 084	d45 084	d55 084	d60 084	d60 084	d50 084	d40 084
d55 088	d55 088	d45 088	d55 088	d60 088	d60 088	d50 088	d40 088
d55 092	d55 092	d45 092	d55 092	d60 092	d60 092	d50 092	d40 092
d55 096	d55 096	d45 096	d55 096	d60 096	d60 096	d50 096	d40 096
d55 100	d55 100	d45 100	d55 100	d60 100	d60 100	d50 100	d40 100
d55 104	d55 104	d45 104	d55 104	d60 104	d60 104	d50 104	d40 104
d55 108	d55 108	d45 108	d55 108	d60 108	d60 108	d50 108	d40 108
d55 112	d55 112	d45 112	d55 112	d60 112	d60 112	d50 112	d40 112
d55 116	d55 116	d45 116	d55 116	d60 116	d60 116	d50 116	d40 116
d55 120	d55 120	d45 120	d55 120	d60 120	d60 120	d50 120	d40 120
d55 124	d55 124	d45 124	d55 124	d60 124	d60 124	d50 124	d40 124
d55 128	d55 128	d45 128	d55 128	d60 128	d60 128	d50 128	d40 128
d55 132	d55 132	d45 132	d55 132	d60 132	d60 132	d50 132	d40 132
d55 136	d55 136	d45 136	d55 136	d60 136	d60 136	d50 136	d40 136
d55 140	d55 140	d45 140	d55 140	d60 140	d60 140	d50 140	d40 140
d55 144	d55 144	d45 144	d55 144	d60 144	d60 144	d50 144	d40 144
d55 5c	d55 5c						

For the calculations described above, the waste package diameter and shell thickness are based on the dimensions of a 21-PWR waste package (Ref. 19). Note that the waste package outer shell thickness of 25 mm instead of 20 mm is used in the calculation. This thickness difference, although it may have a small impact on the waste package internal temperature, will not affect the waste package surface temperature results, which is of concern for this calculation.

The design of the drift invert (SR Baseline Case and Case 3) requires using two layers of materials. The top region is composed of steel beams and ballast material (sand) and the bottom region is composed of only ballast material (see Ref. 20, p. 25 for the design). The sand material is filled to the top of the steel invert giving it a height of 0.806 m (Ref. 20, p. 24) from the

Originator: HM Date: 5/29/02

Checker: MH Date: 5/29/02

bottom of the drift. The sand-filled steel invert structure is represented in ANSYS using homogenous thermal properties calculated in Ref. 4. Geometrically, the top region has a depth of a W12X65 beam from the surface of the invert. Page 1-28 of Ref. 14 lists the depth of a W12X65 beam as 12.12 inches (0.3078 m).

The design details and overall dimensions of the drip shield are provided in Ref. 23. In this calculation, the drip shield is simplified as titanium plate with a width of 2.512 m, a top radius of curvature of 1.285 m, and a thickness of 15 mm.

All other dimensions of the alternative in-drift configurations are in Section 5.1.1.

Table 5-2 lists the key dimensions used in this calculation.

Table 5-2. Key Dimensions Used in the Calculation

Description	Dimension
Waste Package Outer Diameter	1.564 m
Waste Package Inner Shell Thickness	0.050 m
Waste Package Outer Shell Thickness	0.025 m
Drip Shield Width	2.512 m
Drip Shield Top Radius	1.285 m
Drip Shield Thickness	0.015 m

## 5.2 WASTE PACKAGE DIAMETER EFFECT

The effect of waste package diameter variance on the thermal performance can be estimated by using a simple radiation equation for concentric cylinders (p. 739 of Ref. 17):

$$q_{12} = \frac{\sigma A_1 (T_1^4 - T_2^4)}{\frac{1}{\varepsilon_1} + \frac{1 - \varepsilon_2}{\varepsilon_2} \left( \frac{r_1}{r_2} \right)} \quad (\text{Equation 5-3})$$

where:

$q_{12}$  = heat transfer rate from waste package to drift (W)

$\sigma$  = Stefan-Boltzmann constant =  $5.670 \times 10^{-8} \text{ W/m}^2 \cdot \text{K}^4$

$A_1$  = waste package surface area ( $\text{m}^2$ )

$T_1$  = waste package surface temperature (K)

$T_2$  = drift wall temperature (K)

$\varepsilon_1$  = waste package surface emissivity

$\varepsilon_2$  = drift wall emissivity

Since the drift wall temperature remains the same for different waste package diameters as long as the waste package thermal output is the same, the waste package surface temperatures for different waste package diameters are compared against that of a 21 PWR waste package ( $D = 1.564 \text{ m}$ ) for a given drift wall temperature. The drift diameter used in the calculation is 5.5 m,

Originator: HM Date: 5/29/02

Checker: MA Date: 5/29/02

and the waste package diameters of 1 m, 1.5 m, 2 m and 2.5 m are used to evaluate the thermal effect.

The calculation is performed in a Microsoft Excel spreadsheet included in Attachment I (file /Excel\_Files/wpdia.xls).

### 5.3 THERMAL PROPERTIES

The number of digits in the values cited herein may be the result of a calculation or may reflect the results of a units conversion; consequently, it should not be interpreted as an indication of accuracy.

Table 5-3 summarizes the waste package, drip shield, trench, ground support, and rock materials used in the calculation.

Table 5-3. Material List

Name	Material
Waste Package Outer Shell	Alloy 22
Waste Package Inner Shell	316NG
Waste Package Internal	homogeneous material
Drip Shield	Titanium Grade 7
Ground Support Conduit	Titanium Grade 7
Ground Support Conduit Filler	Ballast Material
Trench	Ballast Material
Trench Liner	Alloy 22
Rock	Tptpl

The drift rock material used in the calculation is Tptpl, since the location of the proposed repository is limited to the TSw2 geologic unit at an elevation of 1072.3 meters (Ref. 18, p. 16), which is located in the Tptpl according to the rock layer thicknesses (Ref. 8). Table 5-4 lists thermal conductivity and emissivity of the drift rock (Tptpl) taken from Ref. 8 (see Assumption 3.5) and Ref. 17, page 853 (for rock), respectively.

Table 5-4. Thermal Properties of the Drift Rock

Emissivity	Thermal Conductivity (W/m-K)	
	T $\leq$ 100°C	T $>$ 100°C
0.92	2.02	1.20

To simplify the waste package emplacement representation, the waste package is assumed to be emplaced in the drift as a homogeneous heat-generating cylinder (Assumption 3.1). The effective thermal conductivity for the waste package internal homogeneous cylinder is taken from Ref. 9, Equation 5.1.3-2 for a 21-PWR (pressurized water reactor) waste package. Table 5-5 lists the effective thermal conductivity of the waste package internal cylinder.

Originator: l/m Date: 5/29/02

Checker: MH Date: 5/29/02

Table 5-5. Effective Thermal Conductivity of the Waste Package Internal Cylinder

Thermal Conductivity (W/m-K)
1.5

Table 5-6 lists the thermal conductivity of Alloy 22, the outer shell and trench liner material. Values for thermal conductivity are taken from Ref. 12, p. 13.

The material properties of stainless steel 316 are used for the inner shell material, stainless steel 316NG. Stainless steel 316NG, which is 316 with tightened control on carbon and nitrogen content, has the same mechanical and physical properties as 316 (see Ref. 16, page 931 and Ref. 15, SA-240 in Section II, Table U). Table 5-7 lists the thermal conductivity of stainless steel 316NG. Values for thermal conductivity of stainless steel 316NG (16Cr-12Ni-2Mo) are taken from Ref. 15, Section II, Table TCD.

Table 5-8 lists the emissivity of the outer shell and trench liner material Alloy 22. The emissivity is taken from Ref. 11, p. 10-297 for nickel-chromium alloy.

Table 5-6. Thermal Conductivity of Alloy 22

Temperature (°C)	Thermal Conductivity (W/m-K)
48	10.1
100	11.1
200	13.4
300	15.5
400	17.5
500	19.5
600	21.3

Table 5-7. Thermal Conductivity of 316NG

Temperature		Thermal Conductivity (Btu/hr-ft-°F)	Thermal Conductivity (W/m-K)
(°F)	(°C)		
70	21.11	7.7	13.33
100	37.78	7.9	13.67
150	65.56	8.2	14.19
200	93.33	8.4	14.54
250	121.11	8.7	15.06
300	148.89	9.0	15.58
350	176.67	9.2	15.92
400	204.44	9.5	16.44
450	232.22	9.8	16.96
500	260.00	10.0	17.31
550	287.78	10.3	17.83
600	315.56	10.5	18.17
650	343.33	10.7	18.52
700	371.11	11.0	19.04
750	398.89	11.2	19.38
800	426.67	11.5	19.90

Originator: HM Date: 5/29/02

Checker: MH Date: 5/29/02



Table 5-8. Emissivity of Alloy 22

Emissivity
0.87

Table 5-9 lists the emissivity of Titanium Grade 7 used as the drip shield and conduit material. The emissivity of Titanium Grade 7 is from Ref. 11, Page 10-298, and generalized as that of titanium.

Table 5-10 lists the thermal conductivity of Titanium Grade 7. The thermal conductivity is taken from Ref. 15, Section II, Table TCD.

Table 5-9. Emissivity of Titanium Grade 7

Emissivity
0.63

Table 5-10. Thermal Conductivity of Titanium Grade 7

Temperature		Thermal Conductivity (Btu/hr-ft. <sup>2</sup> °F)	Thermal Conductivity (W/m·K)
(°F)	(°C)		
70	21.11	12.68	21.95
100	37.78	12.52	21.67
150	65.56	12.25	21.20
200	93.33	12.00	20.77
250	121.11	11.85	20.51
300	148.89	11.72	20.28
350	176.67	11.60	20.08
400	204.44	11.45	19.82
450	232.22	11.35	19.64
500	260.00	11.29	19.54
550	287.78	11.23	19.44
600	315.56	11.20	19.38
650	343.33	11.17	19.33
700	371.11	11.15	19.30
750	398.89	11.18	19.35
800	426.67	11.20	19.38
850	454.44	11.23	19.44
900	482.22	11.30	19.56
950	510.00	11.36	19.66
1000	537.78	11.43	19.78
1050	565.56	11.51	19.92
1100	593.33	11.58	20.04

Table 5-11 lists the effective thermal conductivity of the invert top layer (composed of steel beams and ballast material), which is taken from Ref. 4, Tables 6-4, 6-8 and 6-12. Table 5-12 lists the properties of the invert bottom layer and conduit filler, which are ballast material. The

Originator: HM Date: 5/29/02

Checker: MH Date: 5/29/02

thermal conductivity is based on Assumption 3.2. The emissivity of sand (Table A.11, Ref. 17) is used for the invert surface listed in Table 5-12.

Table 5-11. Effective Thermal Conductivity of the Invert (top layer)

Temperature (°C)	Thermal Conductivity (W/m-K)		
	Vertical	Lateral	Axial
50	7.078	1.735	1.206
100	7.163	1.723	1.212
150	7.170	1.705	1.210
200	7.111	1.680	1.202
250	7.001	1.651	1.187
300	6.852	1.617	1.168
350	6.678	1.580	1.145

Table 5-12. Thermal Properties of Invert Ballast Material (bottom layer)

Thermal Conductivity (W/m-K)	Emissivity
0.2	0.9

#### 5.4 ANSYS FILES

This section briefly describes the ANSYS format used to develop the thermal representations.

The format of the input file normally includes the following:

- 1) Describe the file names, problem evaluated, and additional files needed to run the input file, etc.
- 2) Define parameters and dimensions which are repeatedly used in the representation.
- 3) Read in additional files, i.e., material property files and heat load files needed for the execution.
- 4) Define element types used in the file.
- 5) Define geometry and generate mesh.
- 6) Apply the body load (heat output) and boundary conditions and solve the problem.
- 7) Extract temperature results at desired locations in the representation.

All ANSYS files including material properties files (.dat) and output files (.out) are stored on a compact disc (Attachment I) and summarized in Attachment II, Table II-1.

The mesh of the finite element representation is appropriately generated according to standard engineering practice. Thus, the accuracy and representativeness of the results of this thermal calculation is deemed acceptable.

Originator: HM Date: 5/29/02

Checker: MH Date: 5/29/02

## 6. RESULTS

### 6.1 ALTERNATIVE IN-DRIFT CONFIGURATION TEMPERATURE RESULTS

Tables 6-1 through 6-8 list the maximum waste package surface and drift wall temperatures at different instantaneous linear thermal loads and different rock boundary conditions for the SR Baseline case and alternative in-drift configurations cases.

Figures 6-1, 6-3, 6-5, 6-7, 6-9, 6-11, 6-13, and 6-15 show the waste package surface temperature comparison with that of the SR base design (with drip shield) at different instantaneous linear heat loads. For any rock boundary conditions, all cases except for (1) and (2) with conduit / ballast ground support design have lower waste package surface temperatures than the SR base design.

Figure 6-11 shows the 5m-into-rock temperature condition at 70°C. This boundary condition is similar to that of post-closure at 200-300 years (Ref. 3, Figures 6-4 and 6-5). The instantaneous linear heat load for a 2-m waste package spacing at these times is about 0.12-0.15 kW/m. Therefore the temperature difference between the alternative cases and the SR base design becomes insignificant.

Similar results can be observed in the drift wall temperature comparison shown in Figures 6-2, 6-4, 6-6, 6-8, 6-10, 6-12, 6-14, and 6-16. The drift wall temperatures do not change significantly for the alternative in-drift configurations.

Figure 6-17 shows the ANSYS representations and temperature contours for all the cases at rock temperature of 70°C.

### 6.2 IN-DRIFT THERMAL RESISTANCE

The thermal resistance calculated for SR Baseline Case and the Case 2 (See Attachment I, Files: /Excel\_Files:/d55\_cir\_fit.xls; /Excel\_Files:/d55\_cir\_nodrip\_fit.xls; /Excel\_Files:/d55\_trh\_gs\_fit.xls) are listed as follows:

SR Baseline Case (with drip shield):

$$R = 123.60980 - 1.04808 \times T_m + 0.00504 \times T_m^2 - 1.40067e-5 \times T_m^3 + 1.67707e-8 \times T_m^4$$

(Equation 6-1)

SR Baseline Case (without drip shield):

$$R = 69.41964 - 0.59251 \times T_m + 0.00290 \times T_m^2 - 8.19436e-6 \times T_m^3 + 1.00068e-8 \times T_m^4$$

(Equation 6-2)

Case 2:

$$R = 116.24725 - 0.57115 \times T_m + 0.00214 \times T_m^2 - 3.62399e-6 \times T_m^3 + 2.13395e-9 \times T_m^4$$

(Equation 6-3)

Originator: HM Date: 5/29/02

Checker: MH Date: 6/29/02

Table 6-1. Temperature Results for SR Baseline Case (D = 5.5 m; circular; with drip shield)

B.C. at 5m-into-rock (°C)	Case Name	Instantaneous Linear Heat (kW/m)	Max. Waste Package Surface Temperature (°C)	Max. Drift Wall Temperature (°C)	Case Name	Instantaneous Linear Heat (kW/m)	Max. Waste Package Surface Temperature (°C)	Max. Drift Wall Temperature (°C)	Case Name	Instantaneous Linear Heat (kW/m)	Max. Waste Package Surface Temperature (°C)	Max. Drift Wall Temperature (°C)
5°	/SR_dp/d55_001	0.01	7.0	5.8	/SR_dp/d55_052	0.52	85.4	47.8	/SR_dp/d55_104	1.04	143.9	91.1
20		0.01	21.8	20.8		0.52	97.0	62.9		1.04	156.0	108.0
30		0.01	31.8	30.8		0.52	105.0	72.9		1.04	166.0	121.5
40		0.01	41.7	40.8		0.52	113.0	83.0		1.04	176.6	135.6
50		0.01	51.6	50.8		0.52	121.3	93.0		1.04	187.9	149.9
60		0.01	61.6	60.8		0.52	130.3	103.9		1.04	198.3	162.8
70		0.01	71.5	70.8		0.52	141.8	117.7		1.04	210.1	177.2
80		0.01	81.5	80.8		0.52	153.7	131.4		1.04	222.1	191.5
90		0.01	91.4	90.8		0.52	166.1	145.8		1.04	233.0	204.3
5°	/SR_dp/d55_004	0.04	12.8	8.3	/SR_dp/d55_056	0.56	90.4	51.1	/SR_dp/d55_108	1.08	148.0	94.4
20		0.04	27.3	23.3		0.56	101.9	66.2		1.08	160.9	112.5
30		0.04	37.0	33.3		0.56	109.8	76.2		1.08	171.0	126.3
40		0.04	46.7	43.3		0.56	117.8	86.3		1.08	181.1	139.5
50		0.04	56.4	53.3		0.56	126.0	96.3		1.08	192.5	154.0
60		0.04	66.2	63.3		0.56	135.9	108.4		1.08	204.1	168.4
70		0.04	76.0	73.3		0.56	147.5	122.4		1.08	214.8	181.4
80		0.04	85.8	83.3		0.56	159.4	136.2		1.08	226.9	195.9
90		0.04	95.7	93.3		0.56	171.5	150.0		1.08	238.2	209.2
5°	/SR_dp/d55_008	0.08	20.2	11.5	/SR_dp/d55_060	0.6	95.3	54.4	/SR_dp/d55_112	1.12	152.0	97.8
20		0.08	34.2	26.5		0.6	106.7	69.5		1.12	165.8	117.1
30		0.08	43.6	36.6		0.6	114.5	79.6		1.12	176.0	131.0
40		0.08	53.1	46.6		0.6	122.5	89.6		1.12	186.8	145.2
50		0.08	62.7	56.6		0.6	130.6	99.7		1.12	197.0	158.1
60		0.08	72.2	66.6		0.6	141.3	112.9		1.12	208.8	172.8
70		0.08	81.9	76.6		0.6	152.8	126.6		1.12	219.6	185.9
80		0.08	91.5	86.6		0.6	164.6	140.5		1.12	231.7	200.3
90		0.08	101.2	96.6		0.6	176.8	154.4		1.12	243.8	214.6
5°	/SR_dp/d55_012	0.12	27.3	14.8	/SR_dp/d55_064	0.64	100.1	57.8	/SR_dp/d55_116	1.16	156.1	101.2
20		0.12	40.9	29.8		0.64	111.4	72.8		1.16	170.7	121.8
30		0.12	50.1	39.8		0.64	119.2	82.9		1.16	180.5	135.1
40		0.12	59.3	49.9		0.64	127.1	92.9		1.16	191.3	149.2
50		0.12	68.7	59.9		0.64	135.8	103.8		1.16	202.8	163.8
60		0.12	78.1	69.9		0.64	146.8	117.5		1.16	213.4	177.0
70		0.12	87.6	79.9		0.64	158.5	131.5		1.16	225.4	191.5
80		0.12	97.1	89.9		0.64	170.4	145.5		1.16	236.4	204.7
90		0.12	106.6	100.0		0.64	182.1	158.9		1.16	248.8	219.4
5°	/SR_dp/d55_016	0.16	34.0	18.1	/SR_dp/d55_068	0.68	104.8	61.1	/SR_dp/d55_120	1.2	160.7	105.6
20		0.16	47.3	33.1		0.68	116.0	76.2		1.2	175.1	125.9
30		0.16	56.3	43.1		0.68	123.8	86.2		1.2	185.7	140.2

Originator: HM Date: 5/29/02

Checker: MH Date: 5/29/02

B.C. at 5m-into-rock (°C)	Case Name	Instantaneous Linear Heat (kW/m)	Max. Waste Package Surface Temperature (°C)	Max. Drift Wall Temperature (°C)	Case Name	Instantaneous Linear Heat (kW/m)	Max. Waste Package Surface Temperature (°C)	Max. Drift Wall Temperature (°C)	Case Name	Instantaneous Linear Heat (kW/m)	Max. Waste Package Surface Temperature (°C)	Max. Drift Wall Temperature (°C)
40		0.16	65.4	53.1		0.68	131.6	96.3		1.2	195.7	153.2
50		0.16	74.5	63.2		0.68	141.1	108.3		1.2	207.4	168.1
60		0.16	83.8	73.2		0.68	152.2	122.0		1.2	218.0	181.2
70		0.16	93.1	83.2		0.68	163.6	135.7		1.2	230.2	196.1
80		0.16	102.5	93.2		0.68	175.7	149.9		1.2	241.1	209.1
90		0.16	112.9	104.3		0.68	187.6	163.7		1.2	253.7	224.0
5°		0.2	40.4	21.3		0.72	109.4	84.4		1.24	165.3	110.0
20		0.2	53.5	36.4		0.72	120.6	79.5		1.24	180.0	130.6
30		0.2	62.3	46.4		0.72	128.3	89.5		1.24	190.0	144.2
40		0.2	71.2	56.4		0.72	136.1	99.6		1.24	201.5	159.1
50		0.2	80.2	66.5		0.72	146.4	112.8		1.24	211.9	172.3
60		0.2	89.3	76.5		0.72	157.3	126.3		1.24	223.1	186.1
70		0.2	98.5	86.5		0.72	169.3	140.7		1.24	234.9	200.5
80		0.2	107.8	96.5		0.72	180.7	154.2		1.24	245.9	213.6
90		0.2	119.2	108.9		0.72	193.1	168.6		1.24	258.6	228.6
5°		0.24	46.7	24.6		0.76	114.0	87.7		1.28	170.0	114.7
20		0.24	59.4	39.7		0.76	125.1	82.8		1.28	184.9	135.6
30		0.24	68.1	49.7		0.76	132.7	92.9		1.28	195.1	149.3
40		0.24	76.9	59.8		0.76	141.1	103.7		1.28	206.0	163.3
50		0.24	85.8	69.8		0.76	151.7	117.4		1.28	216.4	176.4
60		0.24	94.7	79.8		0.76	163.0	131.4		1.28	228.5	191.5
70		0.24	103.8	89.8		0.76	174.3	144.9		1.28	239.5	204.8
80		0.24	113.0	99.9		0.76	186.1	158.9		1.28	250.5	218.0
90		0.24	125.3	113.4		0.76	198.3	173.1		1.28	263.4	233.1
5°		0.28	52.7	27.9		0.8	118.4	71.1		1.32	174.8	119.5
20		0.28	65.2	43.0		0.8	129.5	86.2		1.32	189.3	139.6
30		0.28	73.8	53.0		0.8	137.1	96.2		1.32	200.1	154.1
40		0.28	82.4	63.1		0.8	146.3	108.3		1.32	210.4	167.4
50		0.28	91.2	73.1		0.8	156.9	121.9		1.32	221.5	181.5
60		0.28	100.0	83.1		0.8	167.8	135.4		1.32	233.1	195.8
70		0.28	109.0	93.1		0.8	179.7	149.8		1.32	244.0	209.1
80		0.28	118.9	104.2		0.8	191.8	163.9		1.32	255.4	222.7
90		0.28	131.4	118.0		0.8	203.4	177.6		1.32	268.2	237.7
5°		0.32	58.6	31.2		0.84	122.8	74.4		1.36	179.1	123.6
20		0.32	70.9	46.3		0.84	133.8	89.5		1.36	194.4	144.8
30		0.32	79.3	56.3		0.84	141.4	99.5		1.36	204.4	158.2
40		0.32	87.8	66.4		0.84	151.4	112.8		1.36	214.7	171.4
50		0.32	96.5	76.4		0.84	162.0	126.3		1.36	226.8	186.8
60		0.32	105.2	86.4		0.84	173.6	140.7		1.36	237.6	200.2
70		0.32	114.1	96.5		0.84	185.0	154.5		1.36	248.6	213.4
80		0.32	124.8	108.7		0.84	196.6	168.3		1.36	261.2	228.5
90		0.32	137.4	122.5		0.84	208.5	182.1		1.36	273.0	242.3

Originator: HM Date: 5/29/02

Checker: MMH Date: 5/29/02

B.C. at 5m-into-rock (°C)	Case Name	Instantaneous Linear Heat (kW/m)	Max. Waste Package Surface Temperature (°C)	Max. Drift Wall Temperature (°C)	Case Name	Instantaneous Linear Heat (kW/m)	Max. Waste Package Surface Temperature (°C)	Max. Drift Wall Temperature (°C)	Case Name	Instantaneous Linear Heat (kW/m)	Max. Waste Package Surface Temperature (°C)	Max. Drift Wall Temperature (°C)	
5*	/SR_dp/d55_036	0.36	64.2	34.5	/SR_dp/d55_088	0.88	127.2	77.7	/SR_dp/d55_140	1.4	183.8	128.2	
20		0.36	76.4	49.6		0.88	138.1	92.8		1.4	198.6	148.9	
30		0.36	84.6	59.6		0.88	146.2	103.7		1.4	208.7	162.2	
40		0.36	93.1	69.7		0.88	156.5	117.3		1.4	220.6	177.5	
50		0.36	101.6	79.7		0.88	167.2	130.9		1.4	231.3	191.1	
60		0.36	110.3	89.7		0.88	178.4	144.8		1.4	242.2	204.5	
70		0.36	119.1	99.8		0.88	189.8	158.7		1.4	253.1	217.7	
80		0.36	130.8	113.2		0.88	201.5	172.6		1.4	266.0	233.2	
90		0.36	143.2	127.1		0.88	213.5	186.6		1.4	277.7	246.9	
5*	/SR_dp/d55_040	0.4	69.7	37.8	/SR_dp/d55_092	0.92	131.4	81.1	/SR_dp/d55_144	1.44	188.6	133.2	
20		0.4	81.7	52.9		0.92	142.4	96.2		1.44	202.8	152.8	
30		0.4	89.9	63.0		0.92	151.2	108.0		1.44	214.5	168.3	
40		0.4	98.2	73.0		0.92	161.7	122.0		1.44	225.0	181.8	
50		0.4	106.7	83.0		0.92	172.6	135.9		1.44	235.7	195.3	
60		0.4	115.3	93.1		0.92	183.6	149.5		1.44	246.6	208.7	
70		0.4	124.7	104.0		0.92	194.8	163.1		1.44	258.2	222.7	
80		0.4	136.6	117.8		0.92	206.4	176.9		1.44	270.7	237.7	
90		0.4	149.1	131.7		0.92	218.4	191.0		1.44	282.5	251.5	
5*	/SR_dp/d55_044	0.44	75.1	41.1	/SR_dp/d55_096	0.96	135.7	84.4					
20		0.44	86.9	56.2		0.96	146.6	99.5					
30		0.44	95.0	66.3		0.96	156.1	112.5					
40		0.44	103.3	76.3		0.96	166.7	126.5					
50		0.44	111.6	86.4		0.96	177.5	140.3					
60		0.44	120.1	96.4		0.96	188.9	154.4					
70		0.44	130.4	108.5		0.96	200.5	168.5					
80		0.44	142.4	122.3		0.96	211.6	181.7					
90		0.44	154.7	136.2		0.96	223.3	195.4					
5*	/SR_dp/d55_048	0.48	80.3	44.5	/SR_dp/d55_100	1	139.8	87.7					
20		0.48	92.0	59.5		1	151.2	103.6					
30		0.48	100.0	69.6		1	161.1	117.0					
40		0.48	108.2	79.6		1	171.4	130.6					
50		0.48	116.5	89.7		1	182.1	144.3					
60		0.48	124.9	99.7		1	193.6	158.6					
70		0.48	136.1	113.1		1	205.3	172.8					
80		0.48	148.3	127.1		1	217.2	187.1					
90		0.48	140.8			1	228.1	199.8					

Note: \* The case name for this boundary condition is /SR\_dp/d55\_5c.

Originator: HM Date: 5/29/02

Checker: MH Date: 5/29/02

Table 6-2. Temperature Results for SR Baseline Case (D = 5.5 m; circular; without drip shield)

B.C. at 5m-into-rock (°C)	Case Name	Instantaneous Linear Heat (kW/m)	Max. Waste Package Surface Temperature (°C)	Max. Drift Wall Temperature (°C)	Case Name	Instantaneous Linear Heat (kW/m)	Max. Waste Package Surface Temperature (°C)	Max. Drift Wall Temperature (°C)	Case Name	Instantaneous Linear Heat (kW/m)	Max. Waste Package Surface Temperature (°C)	Max. Drift Wall Temperature (°C)
5°	/SR_nd/d55_001	0.01	6.5	5.8	/SR_nd/d55_052	0.52	70.9	48.7	/SR_nd/d55_104	1.04	124.0	92.3
20		0.01	21.4	20.8		0.52	83.7	63.7		1.04	137.9	109.4
30		0.01	31.4	30.8		0.52	92.4	73.7		1.04	149.1	122.9
40		0.01	41.3	40.8		0.52	101.2	83.7		1.04	160.8	136.6
50		0.01	51.3	50.8		0.52	110.1	93.7		1.04	173.1	150.8
60		0.01	61.3	60.8		0.52	120.0	104.7		1.04	184.7	163.9
70		0.01	71.2	70.8		0.52	132.2	118.3		1.04	197.2	177.9
80		0.01	81.2	80.8		0.52	144.9	132.0		1.04	210.2	192.3
90		0.01	91.2	90.8		0.52	157.9	146.1		1.04	221.8	205.1
5°	/SR_nd/d55_004	0.04	10.9	8.4	/SR_nd/d55_056	0.56	75.3	52.0	/SR_nd/d55_108	1.08	127.8	95.7
20		0.04	25.6	23.4		0.56	88.1	67.0		1.08	142.6	113.8
30		0.04	35.4	33.4		0.56	96.7	77.0		1.08	153.9	127.4
40		0.04	45.3	43.4		0.56	105.4	87.0		1.08	165.3	140.8
50		0.04	55.1	53.4		0.56	114.3	97.0		1.08	177.5	154.9
60		0.04	65.0	63.4		0.56	125.2	109.2		1.08	190.2	169.3
70		0.04	74.9	73.4		0.56	137.6	123.1		1.08	201.8	182.2
80		0.04	84.8	83.4		0.56	150.2	136.8		1.08	214.8	196.7
90		0.04	94.7	93.4		0.56	162.9	150.6		1.08	226.9	210.0
5°	/SR_nd/d55_008	0.08	16.7	11.7	/SR_nd/d55_060	0.6	79.8	55.4	/SR_nd/d55_112	1.12	131.6	99.0
20		0.08	31.1	26.7		0.6	92.3	70.4		1.12	147.3	118.3
30		0.08	40.7	36.7		0.6	100.9	80.4		1.12	158.9	132.3
40		0.08	50.4	46.7		0.6	109.6	90.4		1.12	170.7	146.2
50		0.08	60.2	56.7		0.6	118.5	100.4		1.12	181.9	159.0
60		0.08	69.9	66.7		0.6	130.3	113.8		1.12	194.8	173.6
70		0.08	79.7	76.7		0.6	142.5	127.4		1.12	206.7	187.0
80		0.08	89.5	86.7		0.6	155.1	141.2		1.12	219.4	201.1
90		0.08	99.3	96.7		0.6	167.9	155.0		1.12	232.4	215.4
5°	/SR_nd/d55_012	0.12	22.2	15.1	/SR_nd/d55_064	0.64	83.9	58.8	/SR_nd/d55_116	1.16	135.8	103.1
20		0.12	36.4	30.1		0.64	96.5	73.7		1.16	152.1	123.1
30		0.12	45.9	40.1		0.64	105.1	83.7		1.16	163.2	136.3
40		0.12	55.5	50.1		0.64	113.7	93.7		1.16	175.0	150.2
50		0.12	65.1	60.1		0.64	123.4	104.8		1.16	187.7	164.8
60		0.12	74.7	70.1		0.64	135.4	118.4		1.16	199.2	177.9
70		0.12	84.4	80.1		0.64	147.8	132.1		1.16	212.2	192.4
80		0.12	94.1	90.1		0.64	160.6	146.2		1.16	224.0	205.5
90		0.12	103.9	100.1		0.64	172.9	159.5		1.16	237.3	220.1
5°	/SR_nd/d55_016	0.16	27.6	18.4	/SR_nd/d55_068	0.68	88.1	62.1	/SR_nd/d55_120	1.2	140.4	107.5
20		0.16	41.6	33.4		0.68	100.7	77.1		1.2	156.9	127.8
30		0.16	50.9	43.4		0.68	109.2	87.1		1.2	168.3	141.3

Originator: AM Date: 5/29/02

Checker: MH Date: 5/29/02

B.C. at 5m-into-rock (°C)	Case Name	Instantaneous Linear Heat (kW/m)	Max. Waste Package Surface Temperature (°C)	Max. Drift Wall Temperature (°C)	Case Name	Instantaneous Linear Heat (kW/m)	Max. Waste Package Surface Temperature (°C)	Max. Drift Wall Temperature (°C)	Case Name	Instantaneous Linear Heat (kW/m)	Max. Waste Package Surface Temperature (°C)	Max. Drift Wall Temperature (°C)
40		0.16	60.4	53.4		0.68	117.8	97.1		1.2	179.4	154.4
50		0.16	69.9	63.4		0.68	128.4	109.3		1.2	192.2	169.1
60		0.16	79.5	73.4		0.68	140.5	123.0		1.2	203.6	182.0
70		0.16	89.1	83.4		0.68	152.7	136.5		1.2	216.8	196.9
80		0.16	98.7	93.4		0.68	165.5	150.6		1.2	228.6	209.9
90		0.16	109.4	104.6		0.68	178.2	164.4		1.2	242.1	224.7
5°		0.2	32.9	21.8		0.72	92.3	65.5		1.24	144.8	111.8
20		0.2	46.6	36.8		0.72	104.8	80.5		1.24	161.2	131.8
30		0.2	55.9	46.8		0.72	113.3	90.4		1.24	172.4	145.3
40		0.2	65.2	56.8		0.72	121.9	100.5		1.24	185.1	160.1
50	/SR_nd/d55_020	0.2	74.6	66.8	/SR_nd/d55_072	0.72	133.5	113.9	/SR_nd/d55_124	1.24	196.6	173.2
60		0.2	84.1	76.8		0.72	145.3	127.3		1.24	209.2	187.6
70		0.2	93.6	86.8		0.72	158.0	141.4		1.24	221.4	201.3
80		0.2	103.2	96.8		0.72	170.2	154.9		1.24	233.2	214.3
90		0.2	115.0	109.2		0.72	183.4	169.3		1.24	246.8	229.3
5°		0.24	38.0	25.2		0.76	96.4	68.8		1.28	149.2	116.1
20		0.24	51.6	40.1		0.76	108.8	83.8		1.28	166.3	136.9
30		0.24	60.7	50.2		0.76	117.3	93.8		1.28	178.1	151.1
40		0.24	70.0	60.2		0.76	126.8	104.9		1.28	189.5	164.3
50	/SR_nd/d55_024	0.24	79.3	70.1	/SR_nd/d55_076	0.76	138.5	118.5	/SR_nd/d55_128	1.28	200.9	177.4
60		0.24	88.7	80.1		0.76	150.6	132.1		1.28	214.1	192.4
70		0.24	98.2	90.2		0.76	162.7	145.6		1.28	226.0	205.7
80		0.24	107.7	100.2		0.76	175.5	159.8		1.28	237.8	218.7
90		0.24	120.5	113.7		0.76	188.3	173.8		1.28	251.5	233.9
5°		0.28	43.0	28.5		0.8	100.4	72.2		1.32	154.0	120.8
20		0.28	56.4	43.5		0.8	112.9	87.2		1.32	170.4	140.8
30		0.28	65.5	53.5		0.8	121.3	97.2		1.32	182.4	155.2
40		0.28	74.7	63.5		0.8	131.7	109.3		1.32	193.8	168.4
50	/SR_nd/d55_028	0.28	83.9	73.5	/SR_nd/d55_080	0.8	143.5	123.1	/SR_nd/d55_132	1.32	206.7	183.2
60		0.28	93.2	83.5		0.8	155.3	136.4		1.32	218.6	196.7
70		0.28	102.6	93.5		0.8	168.2	150.8		1.32	230.5	210.0
80		0.28	113.0	104.6		0.8	180.7	164.6		1.32	242.8	223.7
90		0.28	126.0	118.3		0.8	193.2	178.3		1.32	256.3	238.5
5°		0.32	47.9	31.9		0.84	104.5	75.5		1.36	158.8	125.7
20		0.32	61.1	46.9		0.84	116.9	90.5		1.36	175.6	146.1
30		0.32	70.1	56.9		0.84	125.3	100.6		1.36	186.7	159.2
40		0.32	79.2	66.9		0.84	136.5	113.8		1.36	198.4	172.9
50	/SR_nd/d55_032	0.32	88.4	76.9	/SR_nd/d55_084	0.84	148.4	127.5	/SR_nd/d55_136	1.36	211.3	187.7
60		0.32	97.7	86.9		0.84	160.7	141.5		1.36	223.1	201.0
70		0.32	107.0	96.9		0.84	173.0	155.2		1.36	234.9	214.3
80		0.32	118.4	109.1		0.84	185.5	169.0		1.36	248.5	229.4
90		0.32	131.4	122.9		0.84	198.1	182.8		1.36	261.0	243.1

Originator: HM Date: 5/29/02

Checker: MH Date: 5/29/02



B.C. at 5m-into-rock (°C)	Case Name	Instantaneous Linear Heat (kW/m)	Max. Waste Package Surface Temperature (°C)	Max. Drift Wall Temperature (°C)	Case Name	Instantaneous Linear Heat (kW/m)	Max. Waste Package Surface Temperature (°C)	Max. Drift Wall Temperature (°C)	Case Name	Instantaneous Linear Heat (kW/m)	Max. Waste Package Surface Temperature (°C)	Max. Drift Wall Temperature (°C)
5'	/SR_nd/d55_038	0.36	52.7	35.3	/SR_nd/d55_088	0.88	108.4	78.9	/SR_nd/d55_140	1.4	162.8	129.5
20		0.36	65.8	50.2		0.88	120.8	93.9		1.4	179.7	150.0
30		0.36	74.7	60.2		0.88	130.0	104.9		1.4	190.9	163.4
40		0.36	83.8	70.2		0.88	141.4	118.3		1.4	204.0	178.6
50		0.36	92.9	80.2		0.88	153.0	131.8		1.4	215.7	192.0
60		0.36	102.0	90.2		0.88	165.2	145.6		1.4	227.5	205.3
70		0.36	111.4	100.3		0.88	177.6	159.5		1.4	239.4	218.6
80		0.36	123.8	113.7		0.88	190.2	173.4		1.4	253.2	234.0
90		0.36	136.7	127.5		0.88	202.9	187.2		1.4	265.7	247.8
5'	/SR_nd/d55_040	0.4	57.4	38.6	/SR_nd/d55_092	0.92	112.4	82.3	/SR_nd/d55_144	1.44	167.8	134.7
20		0.4	70.4	53.6		0.92	124.7	97.2		1.44	184.0	154.3
30		0.4	79.3	63.6		0.92	134.9	109.5		1.44	196.8	169.4
40		0.4	88.2	73.6		0.92	146.3	122.9		1.44	208.4	182.9
50		0.4	97.3	83.6		0.92	158.5	137.1		1.44	220.1	196.3
60		0.4	106.4	93.6		0.92	170.6	150.7		1.44	231.9	209.6
70		0.4	116.6	104.7		0.92	182.5	164.0		1.44	244.8	224.1
80		0.4	129.1	118.3		0.92	194.8	177.7		1.44	257.9	238.5
90		0.4	142.2	132.2		0.92	207.6	191.7		1.44	270.3	252.2
5'	/SR_nd/d55_044	0.44	61.9	42.0	/SR_nd/d55_096	0.96	116.3	85.6				
20		0.44	74.9	56.9		0.96	128.6	100.6				
30		0.44	83.7	66.9		0.96	139.8	114.1				
40		0.44	92.6	76.9		0.96	151.3	127.7				
50		0.44	101.6	86.9		0.96	163.0	141.2				
60		0.44	110.7	96.9		0.96	175.4	155.3				
70		0.44	121.8	109.2		0.96	188.0	169.3				
80		0.44	134.4	122.8		0.96	200.0	182.6				
90		0.44	147.3	136.7		0.96	212.4	196.2				
5'	/SR_nd/d55_048	0.48	66.5	45.3	/SR_nd/d55_100	1	120.1	89.0				
20		0.48	79.3	60.3		1	133.2	105.0				
30		0.48	88.1	70.3		1	144.5	118.6				
40		0.48	96.9	80.3		1	155.9	131.9				
50		0.48	105.9	90.3		1	167.6	145.4				
60		0.48	115.0	100.4		1	179.9	159.4				
70		0.48	127.0	113.7		1	192.6	173.6				
80		0.48	139.8	127.6		1	205.4	187.8				
90		0.48	152.5	141.3		1	217.1	200.6				

Note: \* The case name for this boundary condition is /SR\_nd/d55\_5c.

Originator: HM Date: 5/29/02

Checker: MH Date: 5/29/02

Table 6-3. Temperature Results for Case 1 (D = 4.5 m; circular; trench; ground support)

B.C. at 5m-into-rock (°C)	Case Name	Instantaneous Linear Heat (kW/m)	Max. Waste Package Surface Temperature (°C)	Max. Drift Wall Temperature (°C)	Case Name	Instantaneous Linear Heat (kW/m)	Max. Waste Package Surface Temperature (°C)	Max. Drift Wall Temperature (°C)	Case Name	Instantaneous Linear Heat (kW/m)	Max. Waste Package Surface Temperature (°C)	Max. Drift Wall Temperature (°C)
20	/case1/ d45_001	0.01	22.2	21.6	/case1/ d45_052	0.52	119.3	106.1	/case1/ d45_104	1.04	214.1	200.3
30		0.01	32.1	31.6		0.52	128.5	116.1		1.04	226.8	214.0
40		0.01	42.1	41.6		0.52	137.7	126.1		1.04	240.0	228.2
50		0.01	52.1	51.6		0.52	147.6	136.8		1.04	253.3	242.4
60		0.01	62.0	61.7		0.52	159.7	150.0		1.04	266.2	256.0
70		0.01	72.0	71.7		0.52	172.8	164.0		1.04	279.1	269.7
80		0.01	82.0	81.7		0.52	186.0	177.9		1.04	292.2	283.4
90	0.01	92.0	91.7	0.52	199.0	191.6	1.04	305.7	297.5			
20	/case1/ d45_004	0.04	28.7	28.6	/case1/ d45_058	0.56	126.3	112.7	/case1/ d45_108	1.08	221.5	207.7
30		0.04	38.5	36.6		0.56	135.4	122.7		1.08	234.9	222.2
40		0.04	48.3	46.6		0.56	144.6	132.8		1.08	248.0	236.2
50		0.04	58.2	56.6		0.56	155.5	144.7		1.08	261.0	250.1
60		0.04	68.1	66.6		0.56	167.9	158.0		1.08	274.0	263.9
70		0.04	78.0	76.6		0.56	180.8	171.8		1.08	287.0	277.6
80		0.04	87.9	86.6		0.56	194.0	185.7		1.08	300.3	291.5
90	0.04	97.8	96.6	0.56	207.4	199.8	1.08	313.7	305.5			
20	/case1/ d45_008	0.08	37.0	33.2	/case1/ d45_060	0.6	133.2	119.3	/case1/ d45_112	1.12	230.1	216.6
30		0.08	46.7	43.2		0.6	142.3	129.4		1.12	242.1	229.5
40		0.08	56.5	53.2		0.6	151.5	139.4		1.12	255.4	243.7
50		0.08	66.2	63.2		0.6	163.3	152.3		1.12	268.6	257.8
60		0.08	76.0	73.2		0.6	176.3	166.3		1.12	281.7	271.7
70		0.08	85.8	83.2		0.6	189.1	179.9		1.12	294.9	285.5
80		0.08	95.6	93.2		0.6	202.1	193.6		1.12	308.7	300.0
90	0.08	105.4	103.2	0.6	215.6	207.8	1.12	321.6	313.5			
20	/case1/ d45_012	0.12	45.2	39.8	/case1/ d45_064	0.64	140.1	126.0	/case1/ d45_116	1.16	238.1	224.8
30		0.12	54.8	49.8		0.64	149.2	136.0		1.16	250.8	238.4
40		0.12	64.4	59.8		0.64	159.9	147.7		1.16	262.8	251.3
50		0.12	74.0	69.8		0.64	171.5	160.5		1.16	276.1	265.4
60		0.12	83.7	79.8		0.64	184.1	174.0		1.16	289.4	279.5
70		0.12	93.4	89.9		0.64	197.7	188.4		1.16	302.9	293.6
80		0.12	103.2	99.9		0.64	210.4	201.9		1.16	316.6	307.9
90	0.12	113.5	110.4	0.64	223.6	215.7	1.16	329.6	321.5			
20	/case1/ d45_016	0.16	53.2	46.4	/case1/ d45_068	0.68	147.0	132.8	/case1/ d45_120	1.2	246.1	232.9
30		0.16	62.7	56.4		0.68	156.0	142.7		1.2	258.8	246.6
40		0.16	72.2	66.4		0.68	167.3	155.1		1.2	271.6	260.3
50		0.16	81.8	76.5		0.68	179.3	168.2		1.2	283.7	273.1
60		0.16	91.4	86.5		0.68	192.7	182.5		1.2	297.3	287.4
70		0.16	101.0	96.5		0.68	205.5	196.1		1.2	311.2	302.0
80		0.16	110.7	106.5		0.68	219.0	210.3		1.2	324.4	315.8

Originator: HM Date: 5/29/02

Checker: MN Date: 5/29/02

B.C. at 5m-into-rock (°C)	Case Name	Instantaneous Linear Heat (kW/m)	Max. Waste Package Surface Temperature (°C)	Max. Drift Wall Temperature (°C)	Case Name	Instantaneous Linear Heat (kW/m)	Max. Waste Package Surface Temperature (°C)	Max. Drift Wall Temperature (°C)	Case Name	Instantaneous Linear Heat (kW/m)	Max. Waste Package Surface Temperature (°C)	Max. Drift Wall Temperature (°C)
90	/case1/ d45_020	0.16	122.3	118.5	/case1/ d45_072	0.68	231.5	223.5	/case1/ d45_124	1.2	337.5	329.5
20		0.2	61.0	53.0		0.72	153.8	139.3		1.24	253.8	240.8
30		0.2	70.4	63.0		0.72	163.1	149.6		1.24	267.3	255.2
40		0.2	79.8	73.1		0.72	175.1	162.8		1.24	280.6	269.3
50		0.2	89.3	83.1		0.72	188.0	176.9		1.24	293.4	282.9
60		0.2	98.9	93.1		0.72	201.1	190.8		1.24	305.5	295.6
70		0.2	108.5	103.1		0.72	213.3	203.8		1.24	318.9	309.7
80		0.2	118.1	113.1		0.72	227.0	218.3		1.24	332.2	323.7
90		0.2	131.0	126.6		0.72	239.6	231.4		1.24	345.5	337.5
20	/case1/ d45_024	0.24	68.6	59.6	/case1/ d45_076	0.76	160.5	145.9	/case1/ d45_128	1.28	261.1	248.1
30		0.24	77.9	69.6		0.76	171.6	158.3		1.28	274.7	262.8
40		0.24	87.3	79.7		0.76	183.2	171.1		1.28	288.2	277.1
50		0.24	96.8	89.7		0.76	196.2	185.0		1.28	301.5	291.1
60		0.24	106.3	99.7		0.76	208.6	198.3		1.28	313.6	303.8
70		0.24	115.9	109.8		0.76	222.4	212.9		1.28	326.6	317.5
80		0.24	126.4	120.9		0.76	235.1	226.3		1.28	340.1	331.5
90		0.24	139.7	134.7		0.76	248.0	239.8		1.28	353.4	345.4
20		/case1/ d45_028	0.28	76.1		66.2	/case1/ d45_080	0.8		167.2	152.6	/case1/ d45_132
30	0.28		85.4	76.3	0.8	178.8		165.5	1.32	282.1	270.2	
40	0.28		94.8	86.3	0.8	191.1		178.9	1.32	295.8	284.8	
50	0.28		104.2	96.3	0.8	203.8		192.5	1.32	309.3	299.0	
60	0.28		113.7	106.4	0.8	217.0		206.7	1.32	322.5	312.9	
70	0.28		123.2	116.4	0.8	230.4		220.9	1.32	334.3	325.2	
80	0.28		135.0	128.9	0.8	243.3		234.5	1.32	347.9	339.4	
90	0.28		148.4	142.8	0.8	256.6		248.5	1.32	361.4	353.4	
20	/case1/ d45_032		0.32	83.5	72.8	/case1/ d45_084		0.84	175.6	161.0	/case1/ d45_136	
30		0.32	92.8	82.9	0.84		186.7	173.4	1.36	289.5		277.7
40		0.32	102.1	92.9	0.84		199.5	187.3	1.36	303.3		292.4
50		0.32	111.5	102.9	0.84		212.4	201.2	1.36	317.0		306.9
60		0.32	120.9	113.0	0.84		225.7	215.4	1.36	330.5		321.0
70		0.32	131.1	123.8	0.84		238.3	228.7	1.36	343.0		334.1
80		0.32	143.6	137.0	0.84		251.2	242.3	1.36	355.6		347.2
90		0.32	156.9	150.9	0.84		264.9	256.7	1.36	369.3		361.4
20		/case1/ d45_036	0.36	90.8	79.4		/case1/ d45_088	0.88	183.1	168.8		/case1/ d45_140
30	0.36		100.1	89.5	0.88	194.8		181.7	1.4	298.6	287.1	
40	0.36		109.3	99.6	0.88	207.5		195.4	1.4	310.9	300.1	
50	0.36		118.7	109.6	0.88	220.9		209.7	1.4	324.7	314.7	
60	0.36		128.1	119.7	0.88	233.5		223.1	1.4	338.3	329.0	
70	0.36		139.0	131.3	0.88	246.1		236.5	1.4	351.8	342.8	
80	0.36		152.3	145.3	0.88	259.0		250.1	1.4	363.5	355.1	
90	0.36		165.4	159.1	0.88	273.2		265.0	1.4	377.2	369.4	
20	/case1/ d45_040		0.4	98.1	86.1	/case1/ d45_092		0.92	190.2	175.9	/case1/ d45_144	

Originator: HM Date: 5/29/02

Checker: MH Date: 5/29/02

B.C. at 5m-into-rock (°C)	Case Name	Instantaneous Linear Heat (kW/m)	Max. Waste Package Surface Temperature (°C)	Max. Drift Wall Temperature (°C)	Case Name	Instantaneous Linear Heat (kW/m)	Max. Waste Package Surface Temperature (°C)	Max. Drift Wall Temperature (°C)	Case Name	Instantaneous Linear Heat (kW/m)	Max. Waste Package Surface Temperature (°C)	Max. Drift Wall Temperature (°C)
30		0.4	107.3	96.2		0.92	202.7	189.6		1.44	307.6	296.3
40		0.4	116.5	106.2		0.92	215.7	203.6		1.44	318.4	307.7
50		0.4	125.8	116.2		0.92	228.4	217.3		1.44	332.4	322.5
60		0.4	135.2	126.2		0.92	241.1	230.8		1.44	346.2	336.9
70		0.4	147.4	139.4		0.92	254.2	244.6		1.44	359.7	351.0
80		0.4	160.5	153.2		0.92	267.7	258.9		1.44	371.3	363.0
90		0.4	173.8	167.1		0.92	281.5	273.3		1.44	385.2	377.4
20		0.44	105.2	92.8		0.96	198.2	184.1				
30		0.44	114.4	102.8		0.96	210.1	197.0				
40		0.44	123.6	112.8		0.96	223.1	211.0				
50	/case1/ d45_044	0.44	132.9	122.9	/case1/ d45_096	0.96	235.9	224.8				
60		0.44	143.5	134.3		0.96	248.7	238.4				
70		0.44	156.0	147.7		0.96	262.4	252.8				
80		0.44	169.1	161.5		0.96	276.0	267.2				
90		0.44	182.1	175.1		0.96	289.7	281.5				
20		0.48	112.3	99.4		1	206.3	192.3				
30		0.48	121.4	109.4		1	219.0	206.2				
40		0.48	130.7	119.5		1	231.7	219.8				
50	/case1/ d45_048	0.48	140.0	129.5	/case1/ d45_100	1	244.5	233.5				
60		0.48	151.3	141.8		1	258.2	247.9				
70		0.48	164.1	155.5		1	271.1	261.6				
80		0.48	177.1	169.2		1	284.1	275.3				
90		0.48	190.7	183.5		1	297.7	289.5				

Originator: HM Date: 5/29/02

Checker: MH Date: 5/29/02

Table 6-4. Temperature Results for Case 2 (D = 5.5 m; circular; trench; ground support)

B.C. at 5m-into-rock (°C)	Case Name	Instantaneous Linear Heat (kW/m)	Max. Waste Package Surface Temperature (°C)	Max. Drift Wall Temperature (°C)	Case Name	Instantaneous Linear Heat (kW/m)	Max. Waste Package Surface Temperature (°C)	Max. Drift Wall Temperature (°C)	Case Name	Instantaneous Linear Heat (kW/m)	Max. Waste Package Surface Temperature (°C)	Max. Drift Wall Temperature (°C)
20	/case2/ d55_001	0.01	21.9	20.8	/case2/ d55_052	0.52	105.6	64.1	/case2/ d55_104	1.04	181.6	111.7
30		0.01	31.9	30.8		0.52	114.5	74.1		1.04	193.0	124.9
40		0.01	41.8	40.8		0.52	123.6	84.2		1.04	205.4	138.8
50		0.01	51.8	50.8		0.52	132.7	94.2		1.04	218.2	152.4
60		0.01	61.7	60.8		0.52	143.1	105.8		1.04	230.6	165.8
70		0.01	71.7	70.8		0.52	155.4	119.2		1.04	243.1	179.3
80		0.01	81.7	80.8		0.52	168.2	132.8		1.04	256.9	194.5
90	0.01	91.7	90.8	0.52	181.2	146.8	1.04	270.3	208.4			
20	/case2/ d55_004	0.04	27.5	23.4	/case2/ d55_056	0.56	111.5	67.5	/case2/ d55_108	1.08	187.4	115.4
30		0.04	37.3	33.4		0.56	120.4	77.5		1.08	199.4	129.0
40		0.04	47.2	43.4		0.56	129.5	87.6		1.08	211.8	142.8
50		0.04	57.0	53.4		0.56	138.6	97.6		1.08	224.4	156.5
60		0.04	66.9	63.4		0.56	149.3	109.6		1.08	236.8	170.0
70		0.04	76.8	73.4		0.56	162.0	123.4		1.08	250.0	184.3
80		0.04	86.7	83.4		0.56	175.0	137.5		1.08	263.6	199.2
90	0.04	96.6	93.4	0.56	188.4	151.7	1.08	277.0	213.1			
20	/case2/ d55_008	0.08	34.8	26.7	/case2/ d55_060	0.6	117.3	70.9	/case2/ d55_112	1.12	193.1	119.1
30		0.08	44.5	36.8		0.6	126.3	81.0		1.12	205.3	132.9
40		0.08	54.2	46.8		0.6	135.3	91.0		1.12	218.0	146.8
50		0.08	63.9	56.8		0.6	144.4	101.0		1.12	230.4	160.5
60		0.08	73.7	66.8		0.6	156.5	114.8		1.12	243.6	175.2
70		0.08	83.5	76.8		0.6	169.3	128.7		1.12	257.5	190.2
80		0.08	93.3	86.8		0.6	182.3	142.6		1.12	270.3	203.8
90	0.08	103.1	96.8	0.6	195.3	156.3	1.12	283.6	217.7			
20	/case2/ d55_012	0.12	41.8	30.1	/case2/ d55_064	0.64	123.1	74.3	/case2/ d55_116	1.16	200.7	125.7
30		0.12	51.4	40.1		0.64	132.1	84.4		1.16	212.9	139.5
40		0.12	61.0	50.1		0.64	141.1	94.4		1.16	225.5	153.3
50		0.12	70.6	60.2		0.64	151.4	106.3		1.16	238.1	167.0
60		0.12	80.3	70.2		0.64	162.9	118.7		1.16	251.4	181.1
70		0.12	90.0	80.2		0.64	176.0	133.0		1.16	264.0	194.7
80		0.12	99.7	90.2		0.64	188.9	146.9		1.16	276.8	208.4
90	0.12	109.6	100.3	0.64	202.1	160.9	1.16	290.1	222.2			
20	/case2/ d55_016	0.16	48.7	33.5	/case2/ d55_068	0.68	128.9	77.8	/case2/ d55_120	1.2	206.7	129.7
30		0.16	58.2	43.5		0.68	137.8	87.8		1.2	219.3	143.7
40		0.16	67.7	53.5		0.68	146.9	97.8		1.2	232.0	157.7
50		0.16	77.2	63.6		0.68	157.6	110.0		1.2	245.2	171.8
60		0.16	86.8	73.6		0.68	170.3	124.3		1.2	257.8	185.5
70		0.16	96.5	83.6		0.68	182.6	137.5		1.2	270.5	199.2
80		0.16	106.1	93.6		0.68	195.6	151.3		1.2	283.4	212.9

Originator: Hms Date: 5/29/02

Checker: MH Date: 5/29/02

B.C. at 5m-into-rock (°C)	Case Name	Instantaneous Linear Heat (kW/m)	Max. Waste Package Surface Temperature (°C)	Max. Drift Wall Temperature (°C)	Case Name	Instantaneous Linear Heat (kW/m)	Max. Waste Package Surface Temperature (°C)	Max. Drift Wall Temperature (°C)	Case Name	Instantaneous Linear Heat (kW/m)	Max. Waste Package Surface Temperature (°C)	Max. Drift Wall Temperature (°C)
90		0.16	116.8	104.8		0.68	208.9	165.5		1.2	296.7	226.8
20	/case2/ d55_020	0.2	55.5	36.9	/case2/ d55_072	0.72	134.7	81.2	/case2/ d55_124	1.24	213.1	133.8
30		0.2	64.8	46.9		0.72	143.6	91.2		1.24	225.7	147.9
40		0.2	74.2	56.9		0.72	152.6	101.3		1.24	238.6	162.1
50		0.2	83.7	67.0		0.72	164.6	115.4		1.24	251.4	176.1
60		0.2	93.3	77.0		0.72	176.8	128.4		1.24	264.1	189.9
70		0.2	102.8	87.0		0.72	190.1	142.9		1.24	276.9	203.7
80		0.2	112.4	97.0		0.72	202.5	156.2		1.24	290.2	217.6
90		0.2	124.2	109.4		0.72	215.5	169.9		1.24	303.2	231.4
20	/case2/ d55_024	0.24	62.1	40.3	/case2/ d55_076	0.76	140.4	84.6	/case2/ d55_128	1.28	219.0	137.7
30		0.24	71.4	50.3		0.76	149.3	94.6		1.28	231.9	152.0
40		0.24	80.7	60.3		0.76	159.6	106.8		1.28	244.8	166.2
50		0.24	90.1	70.4		0.76	171.1	119.5		1.28	257.6	180.3
60		0.24	99.6	80.4		0.76	183.4	133.0		1.28	270.4	194.2
70		0.24	109.1	90.4		0.76	196.6	147.2		1.28	283.4	208.1
80		0.24	118.7	100.4		0.76	209.8	161.5		1.28	296.9	222.3
90		0.24	131.5	114.1		0.76	222.1	174.4		1.28	309.8	236.0
20	/case2/ d55_028	0.28	68.6	43.7	/case2/ d55_080	0.8	146.0	88.0	/case2/ d55_132	1.32	226.7	144.5
30		0.28	77.8	53.7		0.8	154.9	98.1		1.32	237.9	156.2
40		0.28	87.1	63.7		0.8	165.7	110.6		1.32	250.8	170.3
50		0.28	96.4	73.7		0.8	177.3	123.4		1.32	263.7	184.4
60		0.28	105.9	83.8		0.8	190.7	138.4		1.32	276.7	198.5
70		0.28	115.3	93.8		0.8	203.0	151.4		1.32	289.9	212.6
80		0.28	125.6	104.9		0.8	216.4	166.0		1.32	303.4	226.8
90		0.28	138.8	118.7		0.8	228.7	178.9		1.32	316.3	240.5
20	/case2/ d55_032	0.32	75.0	47.1	/case2/ d55_084	0.84	151.7	91.5	/case2/ d55_136	1.36	233.1	148.8
30		0.32	84.1	57.1		0.84	160.6	101.5		1.36	245.7	163.0
40		0.32	93.3	67.1		0.84	171.6	114.3		1.36	257.2	175.2
50		0.32	102.6	77.1		0.84	184.8	129.3		1.36	269.9	188.7
60		0.32	112.0	87.2		0.84	197.4	142.7		1.36	283.0	202.8
70		0.32	121.5	97.2		0.84	209.8	156.3		1.36	296.7	217.3
80		0.32	132.8	109.5		0.84	223.0	170.5		1.36	309.8	231.3
90		0.32	146.0	123.4		0.84	235.7	184.0		1.36	322.8	245.1
20	/case2/ d55_036	0.36	81.2	50.5	/case2/ d55_088	0.88	157.3	94.9	/case2/ d55_140	1.4	239.4	153.1
30		0.36	90.3	60.5		0.88	167.5	107.2		1.4	252.1	167.3
40		0.36	99.5	70.5		0.88	179.0	120.2		1.4	264.9	181.5
50		0.36	108.8	80.5		0.88	191.3	133.6		1.4	276.8	194.1
60		0.36	118.1	90.6		0.88	203.6	146.8		1.4	289.8	207.4
70		0.36	127.5	100.6		0.88	217.3	161.9		1.4	303.1	221.7
80		0.36	140.0	114.2		0.88	229.7	175.0		1.4	316.2	235.7
90		0.36	153.1	128.0		0.88	243.0	189.4		1.4	329.3	249.7
20	/case2/ d55_040	0.4	87.4	53.9	/case2/ d55_092	0.92	162.8	98.3	/case2/ d55_144	1.44	245.6	157.2

Originator: HM Date: 5/29/02

Checker: MM Date: 5/29/02

B.C. at 5m-into-rock (°C)	Case Name	Instantaneous Linear Heat (kW/m)	Max. Waste Package Surface Temperature (°C)	Max. Drift Wall Temperature (°C)	Case Name	Instantaneous Linear Heat (kW/m)	Max. Waste Package Surface Temperature (°C)	Max. Drift Wall Temperature (°C)	Case Name	Instantaneous Linear Heat (kW/m)	Max. Waste Package Surface Temperature (°C)	Max. Drift Wall Temperature (°C)
30		0.4	96.5	63.9		0.92	173.7	111.1		1.44	258.8	171.8
40		0.4	105.6	73.9		0.92	185.4	124.3		1.44	272.0	188.3
50		0.4	114.9	84.0		0.92	197.6	137.6		1.44	284.9	200.4
60		0.4	124.2	94.0		0.92	210.8	152.5		1.44	296.4	212.3
70		0.4	134.4	105.2		0.92	223.8	166.2		1.44	309.4	226.1
80		0.4	147.3	119.1		0.92	236.4	179.5		1.44	322.6	240.2
90		0.4	160.3	132.9		0.92	249.8	194.2		1.44	335.8	254.3
20		0.44	93.5	57.3		0.96	168.4	101.7				
30		0.44	102.6	67.3		0.96	179.6	114.8				
40		0.44	111.7	77.3		0.96	191.5	128.2				
50	/case2/ d55_044	0.44	120.9	87.4	/case2/ d55_096	0.96	204.8	143.5				
60		0.44	130.1	97.4		0.96	217.9	157.4				
70		0.44	141.4	110.0		0.96	230.2	170.6				
80		0.44	154.1	123.4		0.96	242.9	183.9				
90		0.44	167.3	137.4		0.96	256.6	198.9				
20		0.48	99.6	60.7		1	175.3	107.7				
30		0.48	108.6	70.7		1	186.6	120.8				
40		0.48	117.7	80.7		1	199.0	134.4				
50	/case2/ d55_048	0.48	126.8	90.8	/case2/ d55_100	1	211.5	148.0				
60		0.48	136.1	100.8		1	224.3	161.7				
70		0.48	146.1	114.1		1	236.6	174.9				
80		0.48	161.5	128.5		1	249.3	188.5				
90		0.48	174.2	141.9		1	263.4	203.6				

Originator: HM Date: 5/29/02

Checker: MH Date: 5/29/02

Table 6-5. Temperature Results for Case 3 (D = 6.0 m; circular)

B.C. at Sm-into-rock (°C)	Case Name	Instantaneous Linear Heat (kW/m)	Max. Waste Package Surface Temperature (°C)	Max. Drift Wall Temperature (°C)	Case Name	Instantaneous Linear Heat (kW/m)	Max. Waste Package Surface Temperature (°C)	Max. Drift Wall Temperature (°C)	Case Name	Instantaneous Linear Heat (kW/m)	Max. Waste Package Surface Temperature (°C)	Max. Drift Wall Temperature (°C)
20	/case3/ d60_001	0.01	21.9	20.8	/case3/ d60_052	0.52	97.0	61.6	/case3/ d60_104	1.04	154.6	104.2
30		0.01	31.8	30.8		0.52	104.9	71.6		1.04	164.2	117.5
40		0.01	41.7	40.8		0.52	112.8	81.6		1.04	174.3	131.0
50		0.01	51.6	50.8		0.52	121.0	91.7		1.04	184.6	144.5
60		0.01	61.6	60.8		0.52	129.5	102.1		1.04	195.7	158.6
70		0.01	71.5	70.8		0.52	140.7	115.5		1.04	207.2	172.7
80		0.01	81.5	80.8		0.52	152.4	129.2		1.04	219.0	186.9
90		0.01	91.4	90.8		0.52	164.6	143.2		1.04	229.8	199.7
20		/case3/ d60_004	0.04	27.3		23.2	/case3/ d60_056	0.56		101.9	64.8	/case3/ d60_108
30	0.04		37.0	33.2	0.56	109.6		74.8	1.08	168.9	121.8	
40	0.04		46.7	43.2	0.56	117.5		84.9	1.08	179.3	135.8	
50	0.04		56.5	53.2	0.56	125.6		94.9	1.08	190.1	149.8	
60	0.04		66.2	63.2	0.56	134.9		106.3	1.08	200.3	162.7	
70	0.04		76.0	73.2	0.56	146.1		119.8	1.08	211.8	176.9	
80	0.04		85.8	83.2	0.56	157.9		133.8	1.08	223.7	191.2	
90	0.04		95.6	93.2	0.56	169.9		147.7	1.08	234.6	204.2	
20	/case3/ d60_008		0.08	34.3	26.4	/case3/ d60_060		0.6	106.6	68.0	/case3/ d60_112	
30		0.08	43.7	36.4	0.6		114.3	78.1	1.12	173.8		126.5
40		0.08	53.2	46.4	0.6		122.2	88.1	1.12	183.6		139.6
50		0.08	62.7	56.4	0.6		130.2	98.1	1.12	194.5		153.8
60		0.08	72.2	66.4	0.6		140.3	110.6	1.12	205.8		168.0
70		0.08	81.8	76.4	0.6		151.6	124.4	1.12	216.3		180.9
80		0.08	91.5	86.4	0.6		163.2	138.1	1.12	228.3		195.4
90		0.08	101.1	96.4	0.6		175.1	151.9	1.12	239.7		209.0
20		/case3/ d60_012	0.12	41.0	29.6		/case3/ d60_064	0.64	111.3	71.3		/case3/ d60_116
30	0.12		50.2	39.6	0.64	118.9		81.3	1.16	178.4	130.7	
40	0.12		59.4	49.6	0.64	126.7		91.3	1.16	189.0	144.9	
50	0.12		68.7	59.6	0.64	134.8		101.6	1.16	198.9	157.7	
60	0.12		78.1	69.6	0.64	145.6		115.0	1.16	210.4	172.1	
70	0.12		87.5	79.6	0.64	156.8		128.7	1.16	221.2	185.5	
80	0.12		97.0	89.6	0.64	168.4		142.4	1.16	232.9	199.6	
90	0.12		106.5	99.6	0.64	180.2		156.1	1.16	245.0	214.0	
20	/case3/ d60_016		0.16	47.4	32.8	/case3/ d60_068		0.68	115.9	74.5	/case3/ d60_120	
30		0.16	56.4	42.8	0.68		123.4	84.5	1.2	183.0		134.9
40		0.16	65.4	52.8	0.68		131.2	94.5	1.2	193.4		148.8
50		0.16	74.5	62.8	0.68		140.0	105.8	1.2	204.2		162.8
60		0.16	83.7	72.8	0.68		150.9	119.4	1.2	214.8		176.2
70		0.16	93.0	82.8	0.68		162.0	133.0	1.2	226.6		190.7
80		0.16	102.4	92.8	0.68		173.9	147.1	1.2	237.4		203.9

Originator: HM Date: 5/29/02

Checker: MH Date: 5/29/02



B.C. at 5m-into-rock (°C)	Case Name	Instantaneous Linear Heat (kW/m)	Max. Waste Package Surface Temperature (°C)	Max. Drift Wall Temperature (°C)	Case Name	Instantaneous Linear Heat (kW/m)	Max. Waste Package Surface Temperature (°C)	Max. Drift Wall Temperature (°C)	Case Name	Instantaneous Linear Heat (kW/m)	Max. Waste Package Surface Temperature (°C)	Max. Drift Wall Temperature (°C)
90	/case3/ d60_020	0.16	112.6	103.7	/case3/ d60_072	0.68	185.5	160.6	/case3/ d60_124	1.2	249.8	218.5
20		0.2	53.6	36.0		0.72	120.4	77.7		1.24	177.6	125.5
30		0.2	62.4	46.0		0.72	127.9	87.7		1.24	187.9	139.7
40		0.2	71.3	56.0		0.72	135.6	97.7		1.24	197.6	152.7
50		0.2	80.2	66.0		0.72	145.2	110.1		1.24	208.8	167.2
60		0.2	89.3	76.0		0.72	156.1	123.8		1.24	219.2	180.2
70		0.2	98.4	86.0		0.72	167.3	137.4		1.24	231.1	195.0
80		0.2	107.6	96.0		0.72	178.8	151.2		1.24	242.0	208.1
90		0.2	118.7	108.1		0.72	190.9	165.4		1.24	254.4	222.9
20	/case3/ d60_024	0.24	59.6	39.2	/case3/ d60_076	0.76	124.8	80.9	/case3/ d60_128	1.28	182.4	130.3
30		0.24	68.2	49.2		0.76	132.3	90.9		1.28	192.2	143.7
40		0.24	76.9	59.2		0.76	140.0	101.1		1.28	203.0	158.0
50		0.24	85.7	69.2		0.76	150.4	114.5		1.28	213.2	171.2
60		0.24	94.7	79.2		0.76	161.1	127.9		1.28	224.1	184.9
70		0.24	103.7	89.2		0.76	172.5	141.9		1.28	235.6	199.2
80		0.24	112.7	99.2		0.76	183.8	155.4		1.28	246.5	212.3
90		0.24	124.7	112.4		0.76	196.0	169.8		1.28	259.1	227.3
20		/case3/ d60_028	0.28	65.4		42.4	/case3/ d60_080	0.8		129.1	84.1	/case3/ d60_132
30	0.28		73.9	52.4	0.8	136.6		94.1	1.32	196.3	147.5	
40	0.28		82.4	62.4	0.8	145.0		105.3	1.32	207.4	162.2	
50	0.28		91.1	72.4	0.8	155.5		118.9	1.32	217.5	175.2	
60	0.28		99.9	82.4	0.8	166.3		132.5	1.32	229.3	190.1	
70	0.28		108.8	92.4	0.8	177.3		145.9	1.32	240.1	203.4	
80	0.28		118.4	103.1	0.8	189.3		160.4	1.32	251.0	216.5	
90	0.28		130.7	116.8	0.8	201.0		174.1	1.32	263.7	231.6	
20	/case3/ d60_032		0.32	71.0	45.6	/case3/ d60_084		0.84	133.4	87.3	/case3/ d60_136	
30		0.32	79.3	55.6	0.84		140.8	97.3	1.36	201.7		153.0
40		0.32	87.8	65.6	0.84		150.0	109.5	1.36	211.6		166.1
50		0.32	96.4	75.6	0.84		160.6	123.3	1.36	222.1		179.7
60		0.32	105.0	85.6	0.84		171.1	136.6	1.36	233.7		194.3
70		0.32	113.8	95.6	0.84		182.8	150.9	1.36	244.5		207.5
80		0.32	124.2	107.4	0.84		194.3	164.7	1.36	255.8		221.2
90		0.32	136.5	121.2	0.84		205.9	178.4	1.36	268.2		236.0
20		/case3/ d60_036	0.36	76.5	48.8		/case3/ d60_088	0.88	137.7	90.5		/case3/ d60_140
30	0.36		84.7	58.8	0.88	145.1		100.6	1.4	205.9	157.0	
40	0.36		93.0	68.8	0.88	154.9		113.8	1.4	215.8	170.0	
50	0.36		101.5	78.8	0.88	165.4		127.4	1.4	227.4	185.0	
60	0.36		110.1	88.8	0.88	176.5		141.4	1.4	238.1	198.4	
70	0.36		118.8	98.8	0.88	187.6		155.1	1.4	248.9	211.7	
80	0.36		130.0	111.8	0.88	199.1		168.9	1.4	261.3	226.6	
90	0.36		142.3	125.6	0.88	210.8		182.7	1.4	272.8	240.3	
20	/case3/ d60_040		0.4	81.8	52.0	/case3/ d60_092		0.92	141.8	93.8	/case3/ d60_144	

Originator: Hm Date: 5/29/02

Checker: MA Date: 5/29/02

Title: Thermal Calculation of the In-Drift Configuration Options

Document Identifier: CAL-WIS-TH-000013 REV A

B.C. at 5m-into-rock (°C)	Case Name	Instantaneous Linear Heat (kW/m)	Max. Waste Package Surface Temperature (°C)	Max. Drift Wall Temperature (°C)	Case Name	Instantaneous Linear Heat (kW/m)	Max. Waste Package Surface Temperature (°C)	Max. Drift Wall Temperature (°C)	Case Name	Instantaneous Linear Heat (kW/m)	Max. Waste Package Surface Temperature (°C)	Max. Drift Wall Temperature (°C)
30		0.4	89.9	62.0		0.92	149.8	104.7		1.44	210.0	160.8
40		0.4	98.1	72.0		0.92	159.9	118.2		1.44	221.2	175.6
50		0.4	106.5	82.0		0.92	170.3	131.7		1.44	231.8	189.2
60		0.4	115.0	92.0		0.92	181.1	145.3		1.44	242.5	202.5
70		0.4	124.0	102.6		0.92	192.3	159.1		1.44	253.3	215.8
80		0.4	135.8	116.2		0.92	203.8	173.0		1.44	265.9	231.1
90		0.4	148.0	130.0		0.92	215.6	186.9		1.44	277.3	244.6
20		0.44	87.0	55.2		0.96	145.9	97.0				
30		0.44	95.0	65.2		0.96	154.7	109.0				
40		0.44	103.1	75.2		0.96	164.9	122.7				
50	/case3/ d60_044	0.44	111.4	85.2	/case3/ d60_096	0.96	175.4	136.4				
60		0.44	119.8	95.2		0.96	186.2	150.0				
70		0.44	129.7	106.9		0.96	197.3	163.6				
80		0.44	141.5	120.6		0.96	208.5	177.2				
90		0.44	153.6	134.4		0.96	220.3	191.2				
20		0.48	92.1	58.4		1	150.0	100.2				
30		0.48	100.0	68.4		1	159.5	113.3				
40		0.48	108.0	78.4		1	169.7	127.0				
50	/case3/ d60_048	0.48	116.2	88.4	/case3/ d60_100	1	180.2	140.7				
60		0.48	124.6	98.5		1	191.2	154.6				
70		0.48	135.2	111.2		1	202.6	168.6				
80		0.48	146.9	124.9		1	213.8	182.1				
90		0.48	159.0	138.7		1	225.1	195.4				

Originator: HM Date: 5/29/02

Checker: MH Date: 5/29/02

Table 6-6. Temperature Results for Case 4 (D = 6.0 m; circular; trench)

B.C. at 5m-into-rock (°C)	Case Name	Instantaneous Linear Heat (kW/m)	Max. Waste Package Surface Temperature (°C)	Max. Drift Wall Temperature (°C)	Case Name	Instantaneous Linear Heat (kW/m)	Max. Waste Package Surface Temperature (°C)	Max. Drift Wall Temperature (°C)	Case Name	Instantaneous Linear Heat (kW/m)	Max. Waste Package Surface Temperature (°C)	Max. Drift Wall Temperature (°C)
20	/case4/ d60_001	0.01	21.6	20.7	/case4/ d60_052	0.52	88.9	58.2	/case4/ d60_104	1.04	141.5	97.1
30		0.01	31.6	30.7		0.52	97.0	68.3		1.04	151.1	109.8
40		0.01	41.5	40.7		0.52	105.2	78.4		1.04	161.7	123.5
50		0.01	51.4	50.7		0.52	113.6	88.4		1.04	173.2	138.0
60		0.01	61.4	60.7		0.52	122.2	98.5		1.04	184.6	152.0
70		0.01	71.3	70.7		0.52	133.5	111.7		1.04	196.1	165.9
80		0.01	81.3	80.7		0.52	145.6	125.6		1.04	207.2	179.1
90		0.01	91.3	90.7		0.52	157.8	139.4		1.04	219.1	193.0
20		/case4/ d60_004	0.04	26.4		22.9	/case4/ d60_056	0.56		93.3	61.2	/case4/ d60_108
30	0.04		36.1	32.9	0.56	101.4		71.3	1.08	155.6	113.9	
40	0.04		45.9	42.9	0.56	109.6		81.4	1.08	166.5	127.9	
50	0.04		55.7	52.9	0.56	117.9		91.4	1.08	177.3	141.6	
60	0.04		65.5	62.9	0.56	126.8		102.0	1.08	188.8	155.8	
70	0.04		75.3	72.9	0.56	138.5		115.7	1.08	200.5	169.9	
80	0.04		85.1	83.0	0.56	150.6		129.6	1.08	212.3	184.0	
90	0.04		95.0	93.0	0.56	163.0		143.7	1.08	223.5	196.9	
20	/case4/ d60_008		0.08	32.6	25.8	/case4/ d60_060		0.6	97.7	64.2	/case4/ d60_112	
30		0.08	42.1	35.8	0.6		105.7	74.3	1.12	160.0		117.9
40		0.08	51.6	45.9	0.6		113.8	84.3	1.12	170.6		131.6
50		0.08	61.2	55.9	0.6		122.1	94.4	1.12	181.7		145.5
60		0.08	70.8	65.9	0.6		131.8	106.0	1.12	193.0		159.5
70		0.08	80.5	75.9	0.6		143.5	119.8	1.12	204.7		173.8
80		0.08	90.2	85.9	0.6		155.7	134.0	1.12	216.7		188.1
90		0.08	99.9	95.9	0.6		167.9	147.9	1.12	227.8		201.0
20		/case4/ d60_012	0.12	38.5	28.7		/case4/ d60_064	0.64	102.0	67.2		/case4/ d60_116
30	0.12		47.8	38.8	0.64	109.9		77.2	1.16	164.3	121.8	
40	0.12		57.1	48.8	0.64	118.0		87.3	1.16	175.4	136.1	
50	0.12		66.5	58.8	0.64	126.2		97.4	1.16	186.7	150.5	
60	0.12		76.0	68.8	0.64	136.8		110.1	1.16	197.7	163.9	
70	0.12		85.5	78.9	0.64	148.6		124.1	1.16	209.2	177.9	
80	0.12		95.1	88.9	0.64	160.5		137.9	1.16	221.2	192.2	
90	0.12		104.7	98.9	0.64	172.7		151.9	1.16	232.4	205.3	
20	/case4/ d60_016		0.16	44.2	31.7	/case4/ d60_068		0.68	106.2	70.1	/case4/ d60_120	
30		0.16	53.3	41.7	0.68		114.1	80.2	1.2	169.0		126.3
40		0.16	62.5	51.7	0.68		122.1	90.3	1.2	179.4		139.7
50		0.16	71.7	61.7	0.68		130.4	100.5	1.2	190.8		154.2
60		0.16	81.0	71.8	0.68		141.7	114.2	1.2	202.5		168.6
70		0.16	90.4	81.8	0.68		153.5	128.1	1.2	213.4		181.7
80		0.16	99.9	91.8	0.68		165.4	142.1	1.2	225.7		196.4

Originator: HM Date: 5/29/02

Checker: MH Date: 5/29/02

B.C. at 5m-into-rock (°C)	Case Name	Instantaneous Linear Heat (kW/m)	Max. Waste Package Surface Temperature (°C)	Max. Drift Wall Temperature (°C)	Case Name	Instantaneous Linear Heat (kW/m)	Max. Waste Package Surface Temperature (°C)	Max. Drift Wall Temperature (°C)	Case Name	Instantaneous Linear Heat (kW/m)	Max. Waste Package Surface Temperature (°C)	Max. Drift Wall Temperature (°C)
90		0.16	110.0	102.5		0.68	177.4	155.8		1.2	237.2	209.9
20	/case4/ d60_020	0.2	49.7	34.6	/case4/ d60_072	0.72	110.3	73.1	/case4/ d60_124	1.24	163.0	116.6
30		0.2	58.6	44.6		0.72	118.2	83.2		1.24	173.3	130.3
40		0.2	67.7	54.7		0.72	126.1	93.3		1.24	184.5	144.9
50		0.2	76.8	64.7		0.72	135.3	104.5		1.24	194.9	157.9
60		0.2	86.0	74.7		0.72	146.7	118.4		1.24	206.7	172.5
70		0.2	95.3	84.8		0.72	158.4	132.3		1.24	218.0	186.1
80		0.2	104.6	94.8		0.72	170.4	146.4		1.24	230.0	200.4
90		0.2	115.6	106.6		0.72	182.2	160.0		1.24	242.1	214.6
20		/case4/ d60_024	0.24	55.0		37.5	/case4/ d60_076	0.76		114.4	78.1	/case4/ d60_128
30	0.24		63.8	47.6	0.76	122.2		88.2	1.28	177.7	134.5	
40	0.24		72.7	57.6	0.76	130.2		98.3	1.28	188.6	148.6	
50	0.24		81.7	67.7	0.76	140.1		108.6	1.28	200.1	163.1	
60	0.24		90.8	77.7	0.76	151.5		122.5	1.28	210.8	176.3	
70	0.24		100.0	87.7	0.76	163.1		136.3	1.28	222.9	190.9	
80	0.24		109.2	97.8	0.76	175.0		150.4	1.28	234.2	204.3	
90	0.24		121.2	110.7	0.76	187.2		164.4	1.28	246.6	218.9	
20	/case4/ d60_028		0.28	60.2	40.4	/case4/ d60_080		0.8	118.5	79.1	/case4/ d60_132	
30		0.28	68.9	50.5	0.8		126.2	89.2	1.32	182.1		138.7
40		0.28	77.7	60.6	0.8		134.2	99.3	1.32	192.6		152.2
50		0.28	86.6	70.6	0.8		144.9	112.7	1.32	204.4		167.1
60		0.28	95.5	80.7	0.8		156.1	126.4	1.32	215.1		180.3
70		0.28	104.6	90.7	0.8		168.1	140.8	1.32	227.1		194.9
80		0.28	114.0	101.0	0.8		179.7	154.3	1.32	238.4		208.2
90		0.28	126.7	114.8	0.8		192.1	168.8	1.32	251.1		223.2
20		/case4/ d60_032	0.32	65.3	43.4		/case4/ d60_084	0.84	122.4	82.1		/case4/ d60_136
30	0.32		73.8	53.5	0.84	130.1		92.2	1.36	186.4	142.9	
40	0.32		82.5	63.5	0.84	138.6		103.0	1.36	197.6	157.3	
50	0.32		91.3	73.6	0.84	149.6		116.8	1.36	208.3	170.8	
60	0.32		100.2	83.6	0.84	161.2		131.0	1.36	219.7	184.7	
70	0.32		109.2	93.7	0.84	172.5		144.5	1.36	231.3	198.9	
80	0.32		119.4	105.0	0.84	184.5		158.7	1.36	242.5	212.2	
90	0.32		132.1	118.9	0.84	196.8		172.9	1.36	255.6	227.5	
20	/case4/ d60_036		0.36	70.2	46.3	/case4/ d60_088		0.88	126.3	85.1	/case4/ d60_140	
30		0.36	78.7	56.4	0.88		134.0	95.2	1.4	190.3		146.4
40		0.36	87.2	66.5	0.88		143.3	107.0	1.4	201.9		161.4
50		0.36	95.9	76.5	0.88		154.3	120.8	1.4	212.3		174.5
60		0.36	104.7	86.6	0.88		165.6	134.7	1.4	224.5		189.6
70		0.36	113.6	96.6	0.88		177.5	149.0	1.4	235.7		203.0
80		0.36	124.8	109.1	0.88		189.3	163.0	1.4	246.7		216.1
90		0.36	137.4	123.0	0.88		201.4	177.0	1.4	260.0		231.7
20		/case4/ d60_040	0.4	75.1	49.3		/case4/ d60_092	0.92	130.2	88.1		/case4/ d60_144

Originator: HM Date: 5/29/02

Checker: MM Date: 5/29/02

B.C. at 5m-into-rock (°C)	Case Name	Instantaneous Linear Heat (kW/m)	Max. Waste Package Surface Temperature (°C)	Max. Drift Wall Temperature (°C)	Case Name	Instantaneous Linear Heat (kW/m)	Max. Waste Package Surface Temperature (°C)	Max. Drift Wall Temperature (°C)	Case Name	Instantaneous Linear Heat (kW/m)	Max. Waste Package Surface Temperature (°C)	Max. Drift Wall Temperature (°C)
30		0.4	83.4	59.4		0.92	137.9	98.2		1.44	195.5	151.9
40		0.4	91.9	69.5		0.92	148.0	111.2		1.44	205.9	165.2
50		0.4	100.5	79.5		0.92	159.0	125.0		1.44	216.7	178.7
60		0.4	109.2	89.6		0.92	170.7	139.5		1.44	228.6	193.5
70		0.4	118.1	99.6		0.92	182.1	153.2		1.44	240.0	207.1
80		0.4	130.1	113.2		0.92	193.9	167.1		1.44	251.1	220.4
90		0.4	142.6	127.1		0.92	205.9	181.0		1.44	264.2	235.8
20		0.44	79.8	52.3		0.96	134.0	91.1				
30		0.44	88.0	62.4		0.96	142.0	101.5				
40		0.44	96.4	72.4		0.96	152.6	115.3				
50	/case4/ d60_044	0.44	104.9	82.5	/case4/ d60_096	0.96	163.8	129.4				
60		0.44	113.6	92.5		0.96	175.1	143.2				
70		0.44	123.1	103.5		0.96	186.5	157.1				
80		0.44	135.3	117.3		0.96	198.4	171.1				
90		0.44	147.8	131.3		0.96	210.3	185.0				
20		0.48	84.4	55.2		1	137.8	94.1				
30		0.48	92.5	65.3		1	146.5	105.6				
40		0.48	100.9	75.4		1	157.1	119.3				
50	/case4/ d60_048	0.48	109.3	85.5	/case4/ d60_100	1	168.0	133.0				
60		0.48	117.9	95.5		1	179.4	147.0				
70		0.48	128.3	107.5		1	191.0	161.0				
80		0.48	140.5	121.5		1	202.7	175.0				
90		0.48	152.9	135.3		1	214.7	189.0				

Originator: Hm Date: 5/29/02

Checker: MMH Date: 5/29/02

Table 6-7. Temperature Results for Case 5 (D = 5.0 m; mailbox)

B.C. at 5m-into-rock (°C)	Case Name	Instantaneous Linear Heat (kW/m)	Max. Waste Package Surface Temperature (°C)	Max. Drift Wall Temperature (°C)	Case Name	Instantaneous Linear Heat (kW/m)	Max. Waste Package Surface Temperature (°C)	Max. Drift Wall Temperature (°C)	Case Name	Instantaneous Linear Heat (kW/m)	Max. Waste Package Surface Temperature (°C)	Max. Drift Wall Temperature (°C)
20	/case5/ d50_001	0.01	21.6	20.7	/case5/ d50_052	0.52	87.8	58.0	/case5/ d50_104	1.04	142.4	97.3
30		0.01	31.5	30.7		0.52	98.0	68.0		1.04	152.6	110.7
40		0.01	41.5	40.7		0.52	104.4	78.1		1.04	163.4	124.4
50		0.01	51.4	50.7		0.52	113.2	88.3		1.04	174.1	137.9
60		0.01	61.4	60.7		0.52	122.6	98.6		1.04	186.0	152.4
70		0.01	71.3	70.7		0.52	134.3	112.1		1.04	197.8	166.7
80		0.01	81.3	80.7		0.52	146.5	126.0		1.04	209.5	180.4
90	0.01	91.2	90.7	0.52	158.7	139.8	1.04	221.1	194.0			
20	/case5/ d50_004	0.04	26.2	22.9	/case5/ d50_056	0.56	92.2	60.9	/case5/ d50_108	1.08	146.4	100.5
30		0.04	36.0	32.9		0.56	100.4	71.0		1.08	157.0	114.4
40		0.04	45.8	42.9		0.56	108.7	81.1		1.08	167.6	128.1
50		0.04	55.6	52.9		0.56	117.8	91.3		1.08	179.2	142.7
60		0.04	65.4	62.9		0.56	127.3	102.0		1.08	190.2	156.1
70		0.04	75.2	72.9		0.56	139.3	116.1		1.08	202.1	170.5
80		0.04	85.1	82.9		0.56	151.4	130.0		1.08	213.9	184.4
90	0.04	94.9	92.9	0.56	163.8	144.0	1.08	225.6	198.1			
20	/case5/ d50_008	0.08	32.2	25.8	/case5/ d50_060	0.6	98.6	63.9	/case5/ d50_112	1.12	150.7	104.1
30		0.08	41.7	35.8		0.6	104.7	74.0		1.12	161.4	118.3
40		0.08	51.3	45.8		0.6	113.2	84.1		1.12	172.6	132.7
50		0.08	60.9	55.8		0.6	122.3	94.4		1.12	184.0	147.0
60		0.08	70.6	65.8		0.6	132.7	106.5		1.12	194.6	160.1
70		0.08	80.3	75.9		0.6	144.5	120.4		1.12	206.4	174.4
80		0.08	90.0	85.9		0.6	156.7	134.4		1.12	218.3	188.4
90	0.08	99.8	95.9	0.6	168.7	148.0	1.12	230.2	202.4			
20	/case5/ d50_012	0.12	38.0	28.7	/case5/ d50_064	0.64	100.9	66.8	/case5/ d50_116	1.16	155.9	109.5
30		0.12	47.3	38.7		0.64	108.9	76.9		1.16	166.5	123.4
40		0.12	56.7	48.7		0.64	117.6	87.2		1.16	177.2	137.1
50		0.12	66.2	58.7		0.64	126.7	97.5		1.16	188.0	150.6
60		0.12	75.7	68.8		0.64	137.5	110.4		1.16	200.0	165.3
70		0.12	85.3	78.8		0.64	149.4	124.3		1.16	210.7	178.3
80		0.12	94.9	88.8		0.64	161.4	138.2		1.16	222.7	192.5
90	0.12	104.7	98.9	0.64	173.7	152.2	1.16	234.8	206.6			
20	/case5/ d50_016	0.16	43.6	31.6	/case5/ d50_068	0.68	105.0	69.8	/case5/ d50_120	1.2	160.3	113.3
30		0.16	52.7	41.6		0.68	113.2	79.9		1.2	171.0	127.4
40		0.16	62.0	51.6		0.68	122.0	90.2		1.2	181.7	141.1
50		0.16	71.3	61.7		0.68	131.1	100.7		1.2	192.2	154.4
60		0.16	80.7	71.7		0.68	143.0	115.0		1.2	204.3	169.3
70		0.16	90.1	81.7		0.68	154.6	128.8		1.2	215.2	182.5
80		0.16	99.6	91.8		0.68	166.6	142.6		1.2	227.1	196.5

Originator: Hm Date: 5/29/02

Checker: MH Date: 5/29/02

B.C. at 5m-into-rock (°C)	Case Name	Instantaneous Linear Heat (kW/m)	Max. Waste Package Surface Temperature (°C)	Max. Drift Wall Temperature (°C)	Case Name	Instantaneous Linear Heat (kW/m)	Max. Waste Package Surface Temperature (°C)	Max. Drift Wall Temperature (°C)	Case Name	Instantaneous Linear Heat (kW/m)	Max. Waste Package Surface Temperature (°C)	Max. Drift Wall Temperature (°C)
90		0.16	110.2	102.6		0.68	178.7	156.5		1.2	239.4	210.9
20	/case5/ d50_020	0.2	49.0	34.5	/case5/ d50_072	0.72	109.2	72.8	/case5/ d50_124	1.24	164.5	117.0
30		0.2	58.0	44.5		0.72	117.6	83.0		1.24	175.0	130.9
40		0.2	67.1	54.6		0.72	126.4	93.3		1.24	185.8	144.8
50		0.2	76.3	64.6		0.72	136.1	105.0		1.24	197.7	159.8
60		0.2	85.6	74.6		0.72	147.5	118.7		1.24	208.5	173.1
70		0.2	94.9	84.7		0.72	159.2	132.5		1.24	220.6	187.7
80		0.2	104.4	94.7		0.72	171.5	146.9		1.24	231.6	200.8
90		0.2	115.9	106.7		0.72	183.5	160.7		1.24	243.9	215.1
20		/case5/ d50_024	0.24	54.2		37.4	/case5/ d50_076	0.76		113.3	75.8	/case5/ d50_128
30	0.24		63.1	47.4	0.76	121.9		86.0	1.28	179.3	134.9	
40	0.24		72.1	57.5	0.76	130.7		96.4	1.28	190.3	149.2	
50	0.24		81.2	67.5	0.76	141.2		109.2	1.28	202.0	163.8	
60	0.24		90.4	77.6	0.76	152.8		123.2	1.28	212.6	176.9	
70	0.24		99.6	87.6	0.76	164.6		137.3	1.28	224.9	191.7	
80	0.24		109.3	97.8	0.76	176.1		150.7	1.28	236.2	205.2	
90	0.24		121.5	110.8	0.76	188.3		164.7	1.28	248.3	219.3	
20	/case5/ d50_028		0.28	59.4	40.3	/case5/ d50_080		0.8	117.6	78.8	/case5/ d50_132	
30		0.28	68.1	50.4	0.8		126.2	89.1	1.32	184.6		140.3
40		0.28	77.0	60.4	0.8		134.9	99.5	1.32	195.5		154.2
50		0.28	86.0	70.5	0.8		145.8	113.0	1.32	206.1		167.5
60		0.28	95.0	80.5	0.8		157.6	127.3	1.32	216.9		180.8
70		0.28	104.2	90.6	0.8		169.1	141.0	1.32	229.1		195.6
80		0.28	114.3	101.0	0.8		180.9	154.9	1.32	240.8		209.3
90		0.28	127.1	115.0	0.8		193.0	168.9	1.32	252.6		223.3
20		/case5/ d50_032	0.32	64.4	43.2		/case5/ d50_084	0.84	121.9	81.9		/case5/ d50_136
30	0.32		73.0	53.3	0.84	130.4		92.2	1.36	188.6	144.0	
40	0.32		81.8	63.4	0.84	139.4		103.0	1.36	199.6	158.0	
50	0.32		90.7	73.4	0.84	151.2		117.9	1.36	210.1	171.3	
60	0.32		99.6	83.5	0.84	162.0		131.0	1.36	222.3	186.3	
70	0.32		108.9	93.6	0.84	173.7		145.0	1.36	233.3	199.5	
80	0.32		119.8	105.2	0.84	186.1		159.5	1.36	245.2	213.7	
90	0.32		132.5	119.1	0.84	197.8		173.1	1.36	256.9	227.3	
20	/case5/ d50_036		0.36	69.3	46.2	/case5/ d50_088		0.88	126.1	84.9	/case5/ d50_140	
30		0.36	77.8	56.2	0.88		134.6	95.3	1.4	192.9		148.1
40		0.36	86.5	66.3	0.88		144.8	108.1	1.4	203.5		161.6
50		0.36	95.3	76.4	0.88		155.6	121.5	1.4	214.2		175.1
60		0.36	104.2	86.4	0.88		167.5	136.0	1.4	226.7		190.4
70		0.36	113.7	96.6	0.88		179.0	149.8	1.4	237.5		203.5
80		0.36	125.2	109.3	0.88		190.6	163.5	1.4	249.7		217.9
90		0.36	137.9	123.3	0.88		202.5	177.3	1.4	261.2		231.4
20		/case5/ d50_040	0.4	74.0	49.1		/case5/ d50_092	0.92	130.3	88.0		/case5/ d50_144

Originator: Hm Date: 5/29/02

Checker: MH Date: 5/29/02

B.C. at 5m-into-rock (°C)	Case Name	Instantaneous Linear Heat (kW/m)	Max. Waste Package Surface Temperature (°C)	Max. Drift Wall Temperature (°C)	Case Name	Instantaneous Linear Heat (kW/m)	Max. Waste Package Surface Temperature (°C)	Max. Drift Wall Temperature (°C)	Case Name	Instantaneous Linear Heat (kW/m)	Max. Waste Package Surface Temperature (°C)	Max. Drift Wall Temperature (°C)
30		0.4	82.5	59.2		0.92	138.7	98.4		1.44	196.9	151.8
40		0.4	91.1	69.3		0.92	149.3	111.8		1.44	207.5	165.4
50		0.4	99.8	79.3		0.92	160.2	125.5		1.44	219.9	180.8
60		0.4	108.7	89.4		0.92	171.8	139.7		1.44	230.8	194.3
70		0.4	118.4	99.7		0.92	183.5	153.7		1.44	241.7	207.5
80		0.4	130.7	113.5		0.92	195.1	167.4		1.44	254.0	222.0
90		0.4	143.2	127.4		0.92	207.1	181.4		1.44	265.5	235.5
20		0.44	78.7	52.1		0.96	134.4	91.1				
30		0.44	87.1	62.1		0.96	142.9	101.7				
40		0.44	95.6	72.2		0.96	153.8	115.7				
50	/case5/ d50_044	0.44	104.2	82.3	/case5/ d50_096	0.96	165.3	130.2				
60		0.44	113.4	92.5		0.96	176.1	143.4				
70		0.44	123.8	103.9		0.96	187.8	157.5				
80		0.44	136.1	117.7		0.96	199.6	171.4				
90		0.44	148.5	131.6		0.96	211.8	185.6				
20		0.48	83.3	55.0		1	138.4	94.2				
30		0.48	91.6	65.1		1	147.5	105.9				
40		0.48	100.0	75.2		1	159.1	120.7				
50	/case5/ d50_048	0.48	108.7	85.3	/case5/ d50_100	1	169.9	134.2				
60		0.48	118.1	95.5		1	181.7	148.6				
70		0.48	128.9	107.7		1	192.6	161.8				
80		0.48	141.1	121.7		1	204.4	175.8				
90		0.48	153.5	135.6		1	216.5	189.8				

Originator: HM Date: 5/29/02

Checker: MH Date: 5/29/02



Table 6-8. Temperature Results for Case 6 (D = 4.0 m; mailbox; no drip shield)

B.C. at 5m-into-rock (°C)	Case Name	Instantaneous Linear Heat (kW/m)	Max. Waste Package Surface Temperature (°C)	Max. Drift Wall Temperature (°C)	Case Name	Instantaneous Linear Heat (kW/m)	Max. Waste Package Surface Temperature (°C)	Max. Drift Wall Temperature (°C)	Case Name	Instantaneous Linear Heat (kW/m)	Max. Waste Package Surface Temperature (°C)	Max. Drift Wall Temperature (°C)
20	/case6/ d40_001	0.01	21.4	21.0	/case6/ d40_052	0.52	83.2	70.5	/case6/ d40_104	1.04	143.6	127.6
30		0.01	31.3	31.0		0.52	92.1	80.4		1.04	155.8	141.3
40		0.01	41.3	41.0		0.52	101.2	90.3		1.04	168.0	154.7
50		0.01	51.3	51.0		0.52	110.3	100.3		1.04	180.8	168.6
60		0.01	61.3	61.0		0.52	120.0	113.9		1.04	193.4	182.2
70		0.01	71.2	71.0		0.52	135.7	127.5		1.04	206.3	196.1
80		0.01	81.2	81.0		0.52	148.8	141.3		1.04	219.1	209.7
90	0.01	91.2	91.0	0.52	161.8	155.0	1.04	231.8	223.1			
20	/case6/ d40_004	0.04	25.5	23.9	/case6/ d40_056	0.56	87.5	74.3	/case6/ d40_108	1.08	148.6	132.6
30		0.04	35.3	33.9		0.56	96.4	84.2		1.08	160.7	146.1
40		0.04	45.2	43.9		0.56	105.5	94.2		1.08	173.3	159.9
50		0.04	55.1	53.9		0.56	116.3	105.9		1.08	186.2	174.0
60		0.04	65.0	63.9		0.56	128.4	119.0		1.08	198.5	187.3
70		0.04	74.9	73.9		0.56	141.4	133.0		1.08	211.2	200.9
80		0.04	84.8	83.9		0.56	154.2	146.5		1.08	224.6	215.1
90	0.04	94.7	93.9	0.56	167.5	160.5	1.08	237.0	228.2			
20	/case6/ d40_008	0.08	30.8	27.8	/case6/ d40_060	0.6	91.8	78.2	/case6/ d40_112	1.12	153.6	137.6
30		0.08	40.5	37.8		0.6	100.7	88.1		1.12	166.4	151.8
40		0.08	50.3	47.8		0.6	109.7	98.0		1.12	178.9	165.6
50		0.08	60.1	57.8		0.6	121.0	110.3		1.12	191.3	179.0
60		0.08	69.9	67.8		0.6	134.0	124.4		1.12	204.0	192.7
70		0.08	79.7	77.8		0.6	146.8	138.0		1.12	216.4	206.0
80		0.08	89.5	87.7		0.6	159.8	151.8		1.12	230.4	220.8
90	0.08	99.4	97.7	0.6	173.0	165.8	1.12	242.1	233.3			
20	/case6/ d40_012	0.12	36.0	31.7	/case6/ d40_064	0.64	96.1	82.0	/case6/ d40_116	1.16	159.5	143.6
30		0.12	45.6	41.7		0.64	105.0	91.9		1.16	171.8	157.2
40		0.12	55.3	51.7		0.64	114.0	101.9		1.16	184.0	170.6
50		0.12	65.0	61.7		0.64	127.1	116.2		1.16	196.2	183.9
60		0.12	74.7	71.7		0.64	139.6	129.7		1.16	208.8	197.5
70		0.12	84.4	81.6		0.64	152.5	143.5		1.16	222.1	211.7
80		0.12	94.2	91.6		0.64	165.4	157.2		1.16	235.5	226.0
90	0.12	104.5	102.1	0.64	178.3	170.8	1.16	247.3	238.4			
20	/case6/ d40_016	0.16	41.1	35.6	/case6/ d40_068	0.68	100.3	85.9	/case6/ d40_120	1.2	164.4	148.5
30		0.16	50.6	45.6		0.68	109.2	95.8		1.2	176.6	162.1
40		0.16	60.2	55.6		0.68	120.2	108.0		1.2	188.9	175.6
50		0.16	69.8	65.6		0.68	132.2	121.0		1.2	201.8	189.6
60		0.16	79.4	75.5		0.68	145.0	134.9		1.2	214.7	203.4
70		0.16	89.1	85.5		0.68	157.8	148.6		1.2	227.3	216.9
80		0.16	98.8	95.5		0.68	171.0	162.6		1.2	240.6	231.0

Originator: HM Date: 5/29/02

Checker: MH Date: 5/29/02

B.C. at Sm-Into-rock (°C)	Case Name	Instantaneous Linear Heat (kW/m)	Max. Waste Package Surface Temperature (°C)	Max. Drift Wall Temperature (°C)	Case Name	Instantaneous Linear Heat (kW/m)	Max. Waste Package Surface Temperature (°C)	Max. Drift Wall Temperature (°C)	Case Name	Instantaneous Linear Heat (kW/m)	Max. Waste Package Surface Temperature (°C)	Max. Drift Wall Temperature (°C)
90		0.16	110.4	107.4		0.68	183.5	175.9		1.2	252.6	243.7
20	/case6/ d40_020	0.2	46.1	39.5	/case6/ d40_072	0.72	104.5	89.7	/case6/ d40_124	1.24	169.2	153.3
30		0.2	55.5	49.5		0.72	113.4	99.6		1.24	181.5	168.9
40		0.2	65.0	59.4		0.72	124.9	112.4		1.24	194.3	181.0
50		0.2	74.5	69.4		0.72	136.1	126.8		1.24	207.3	195.0
60		0.2	84.1	79.4		0.72	150.4	140.1		1.24	219.8	208.5
70		0.2	93.7	89.4		0.72	163.3	153.9		1.24	233.1	222.7
80		0.2	103.3	99.3		0.72	176.0	167.5		1.24	245.6	235.9
90		0.2	116.3	112.7		0.72	189.0	181.1		1.24	258.2	249.3
20		/case6/ d40_024	0.24	51.0		43.4	/case6/ d40_076	0.76		108.7	93.5	/case6/ d40_128
30	0.24		60.3	53.4	0.76	117.7		103.7	1.28	187.5	173.0	
40	0.24		69.7	63.3	0.76	131.2		118.6	1.28	199.8	186.6	
50	0.24		79.2	73.3	0.76	143.2		131.6	1.28	212.3	200.1	
60	0.24		88.7	83.3	0.76	156.0		145.6	1.28	225.0	213.7	
70	0.24		98.2	93.2	0.76	168.8		159.3	1.28	238.5	228.1	
80	0.24		108.8	104.2	0.76	181.5		172.7	1.28	250.6	240.9	
90	0.24		122.2	118.0	0.76	194.7		186.7	1.28	263.9	255.0	
20	/case6/ d40_028		0.28	55.8	47.3	/case6/ d40_080		0.8	112.8	97.4	/case6/ d40_132	
30		0.28	65.1	57.2	0.8		124.1	110.0	1.32	192.5		178.1
40		0.28	74.4	67.2	0.8		136.0	123.2	1.32	205.0		191.8
50		0.28	83.8	77.1	0.8		148.8	137.1	1.32	217.2		205.0
60		0.28	93.2	87.1	0.8		161.2	150.5	1.32	231.0		219.7
70		0.28	102.7	97.1	0.8		174.0	164.3	1.32	243.4		233.0
80		0.28	114.7	109.6	0.8		187.1	178.2	1.32	255.6		245.9
90		0.28	127.9	123.3	0.8		200.3	192.2	1.32	269.5		260.5
20		/case6/ d40_032	0.32	60.5	51.2		/case6/ d40_084	0.84	117.0	101.2		/case6/ d40_136
30	0.32		69.7	61.1	0.84	128.7		114.4	1.36	197.5	183.1	
40	0.32		79.0	71.1	0.84	141.3		128.4	1.36	209.8	196.6	
50	0.32		88.3	81.0	0.84	154.2		142.4	1.36	222.5	210.3	
60	0.32		97.7	91.0	0.84	166.9		156.1	1.36	235.8	224.6	
70	0.32		107.2	101.0	0.84	179.5		169.7	1.36	248.3	237.9	
80	0.32		120.5	114.9	0.84	192.8		183.8	1.36	260.6	250.9	
90	0.32		133.8	128.7	0.84	205.9		197.6	1.36	275.1	266.1	
20	/case6/ d40_036		0.36	65.2	55.0	/case6/ d40_088		0.88	122.9	107.2	/case6/ d40_140	
30		0.36	74.3	65.0	0.88		135.2	120.9	1.4	202.3		188.0
40		0.36	83.5	74.9	0.88		147.0	134.0	1.4	214.7		201.5
50		0.36	92.8	84.9	0.88		159.2	147.2	1.4	227.8		215.7
60		0.36	102.1	94.8	0.88		172.2	161.4	1.4	240.6		229.4
70		0.36	113.0	106.2	0.88		184.7	174.7	1.4	253.2		242.8
80		0.36	126.2	120.1	0.88		198.0	188.9	1.4	265.6		255.9
90		0.36	139.4	133.9	0.88		211.1	202.7	1.4	280.5		271.5
20		/case6/ d40_040	0.4	69.8	58.9		/case6/ d40_092	0.92	127.9	112.1		/case6/ d40_144

Originator: HM Date: 5/29/02

Checker: MH Date: 5/29/02

B.C. at 5m-into-rock (°C)	Case Name	Instantaneous Linear Heat (kW/m)	Max. Waste Package Surface Temperature (°C)	Max. Drift Wall Temperature (°C)	Case Name	Instantaneous Linear Heat (kW/m)	Max. Waste Package Surface Temperature (°C)	Max. Drift Wall Temperature (°C)	Case Name	Instantaneous Linear Heat (kW/m)	Max. Waste Package Surface Temperature (°C)	Max. Drift Wall Temperature (°C)
30		0.4	78.8	68.8		0.92	139.8	125.4		1.44	207.5	193.2
40		0.4	88.0	78.8		0.92	152.0	138.9		1.44	220.4	207.3
50		0.4	97.2	88.7		0.92	165.0	153.1		1.44	232.5	220.3
60		0.4	106.5	98.7		0.92	177.2	166.2		1.44	245.4	234.2
70		0.4	118.8	111.6		0.92	190.3	180.3		1.44	258.1	247.7
80		0.4	131.9	125.4		0.92	203.1	193.8		1.44	271.1	261.4
90		0.4	145.1	139.3		0.92	216.3	207.8		1.44	285.6	276.7
20		0.44	74.3	62.8		0.96	132.4	116.4				
30		0.44	83.3	72.7		0.96	144.8	130.3				
40		0.44	92.4	82.6		0.96	157.7	144.5				
50	/case6/ d40_044	0.44	101.6	92.6	/case6/ d40_096	0.96	170.2	158.1				
60		0.44	111.7	103.3		0.96	182.8	171.8				
70		0.44	124.6	117.1		0.96	195.7	185.5				
80		0.44	137.6	130.8		0.96	208.1	198.8				
90		0.44	150.8	144.6		0.96	221.5	212.9				
20		0.48	78.8	66.6		1	138.9	123.1				
30		0.48	87.7	76.6		1	151.0	136.5				
40		0.48	96.8	86.5		1	163.1	149.8				
50	/case6/ d40_048	0.48	106.0	96.4	/case6/ d40_100	1	175.2	163.1				
60		0.48	117.0	108.3		1	188.3	177.2				
70		0.48	130.2	122.3		1	201.4	191.2				
80		0.48	143.1	136.0		1	213.4	204.0				
90		0.48	156.2	149.7		1	226.7	218.0				

Originator: HM Date: 5/29/02

Checker: MH Date: 5/29/02

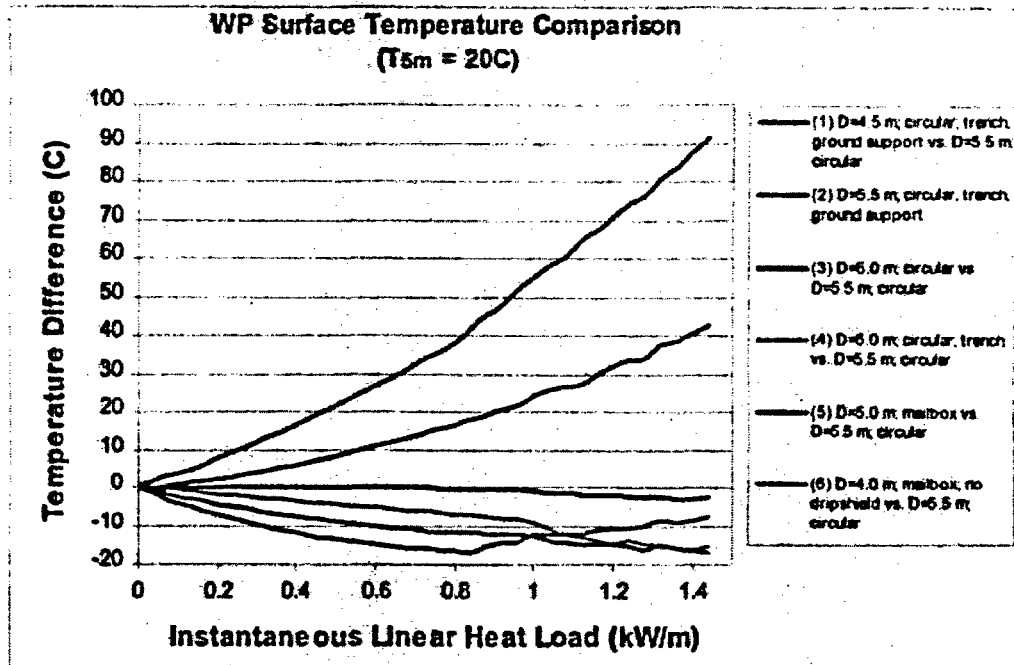

Figure 6-1. Waste Package Surface Temperature Comparison with SR Baseline Design ( $T_{5m}=20^{\circ}\text{C}$ )

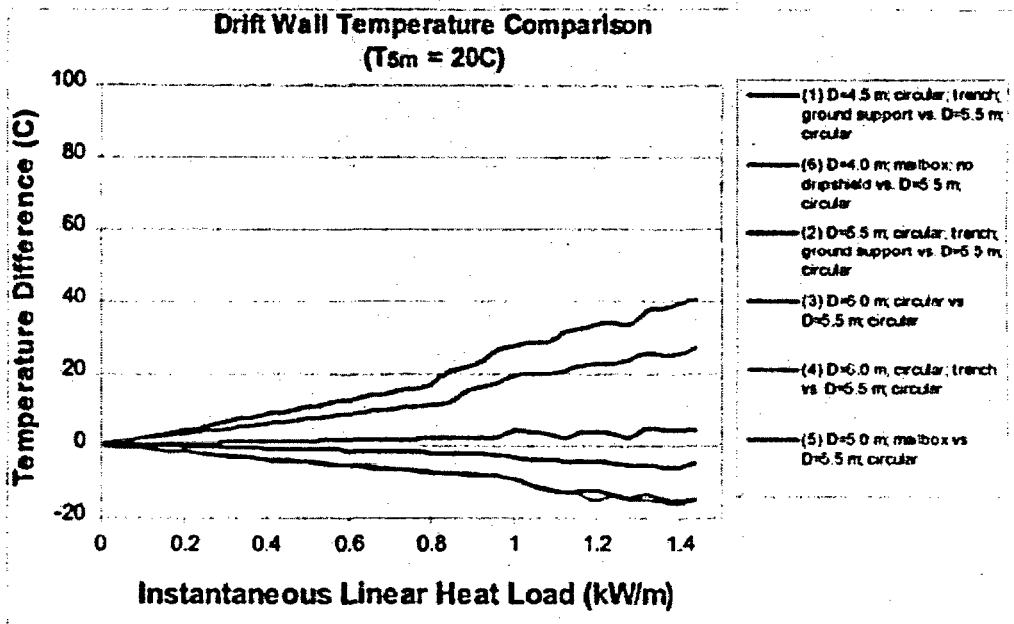

Figure 6-2. Drift Wall Temperature Comparison with SR Baseline Design ( $T_{5m}=20^{\circ}\text{C}$ )

Originator: Hm Date: 5/29/02

Checker: MH Date: 5/29/02

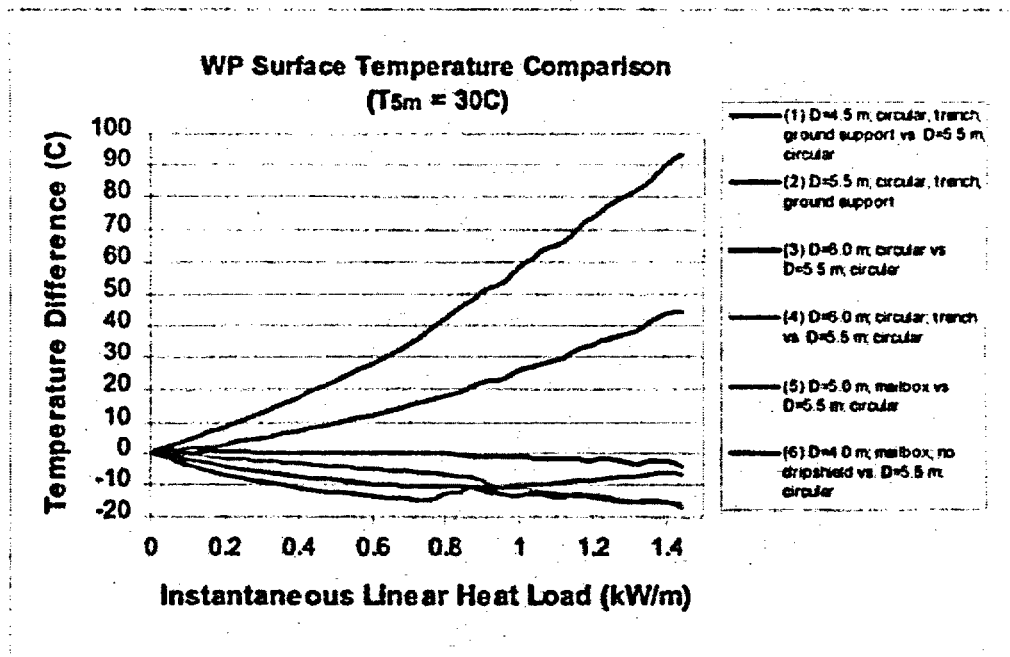

Figure 6-3. Waste Package Surface Temperature Comparison with SR Baseline Design ( $T_{sm}=30^{\circ}C$ )

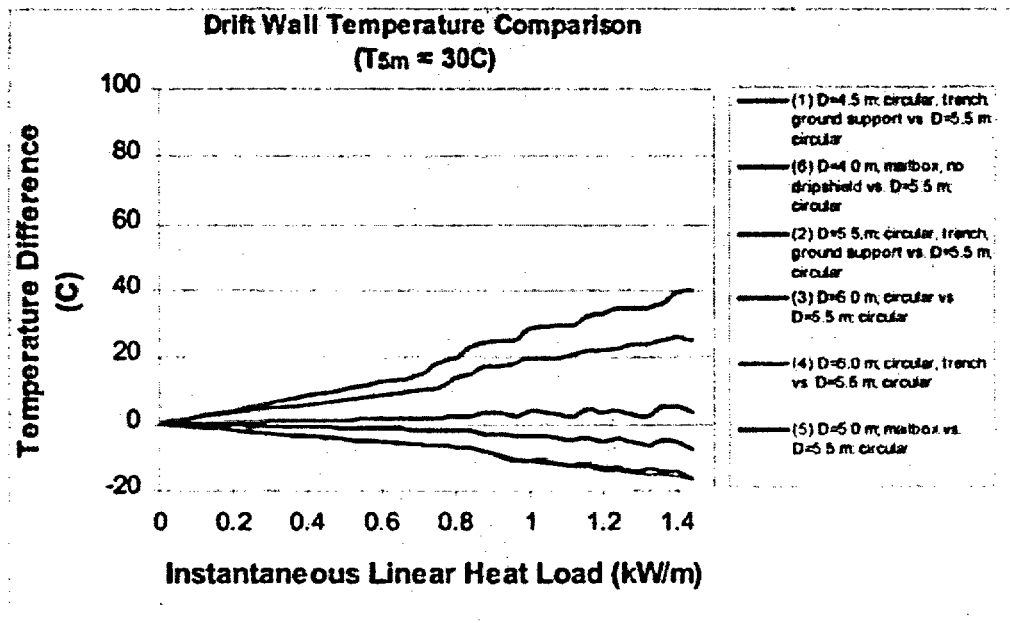

Figure 6-4. Drift Wall Temperature Comparison with SR Baseline Design ( $T_{sm}=30^{\circ}C$ )

Originator: HM Date: 5/29/02

Checker: MLA Date: 5/29/02

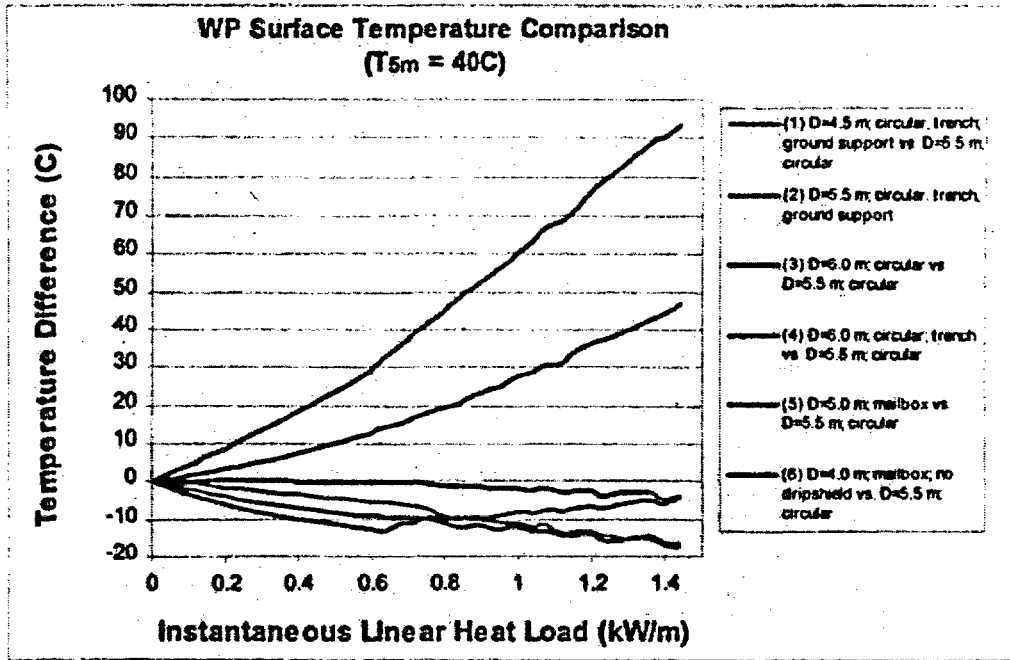

Figure 6-5. Waste Package Surface Temperature Comparison with SR Baseline Design ( $T_{sm}=40^{\circ}C$ )

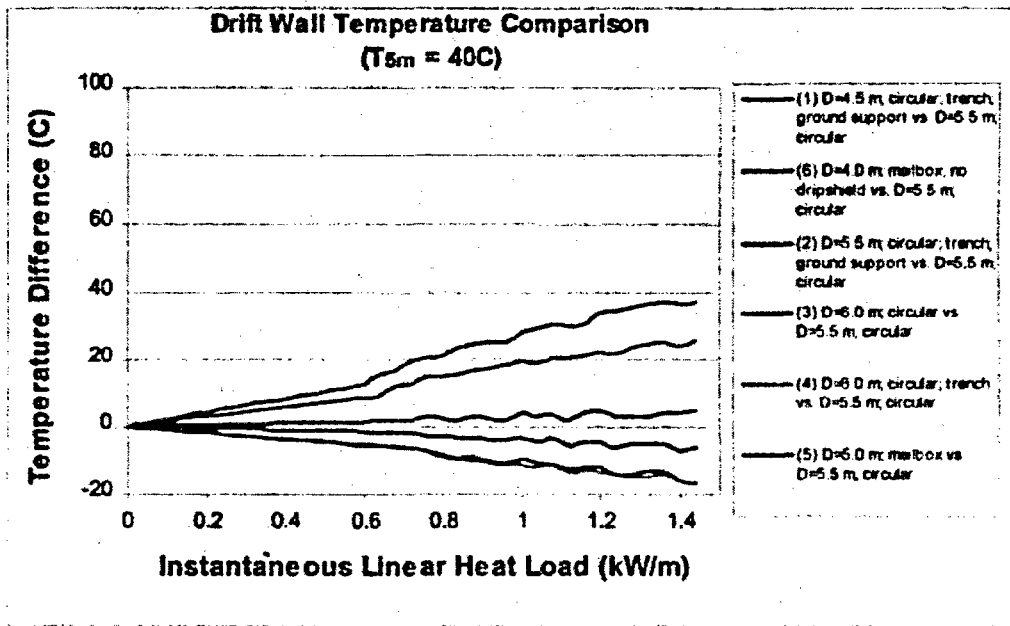

Figure 6-6. Drift Wall Temperature Comparison with SR Baseline Design ( $T_{sm}=40^{\circ}C$ )

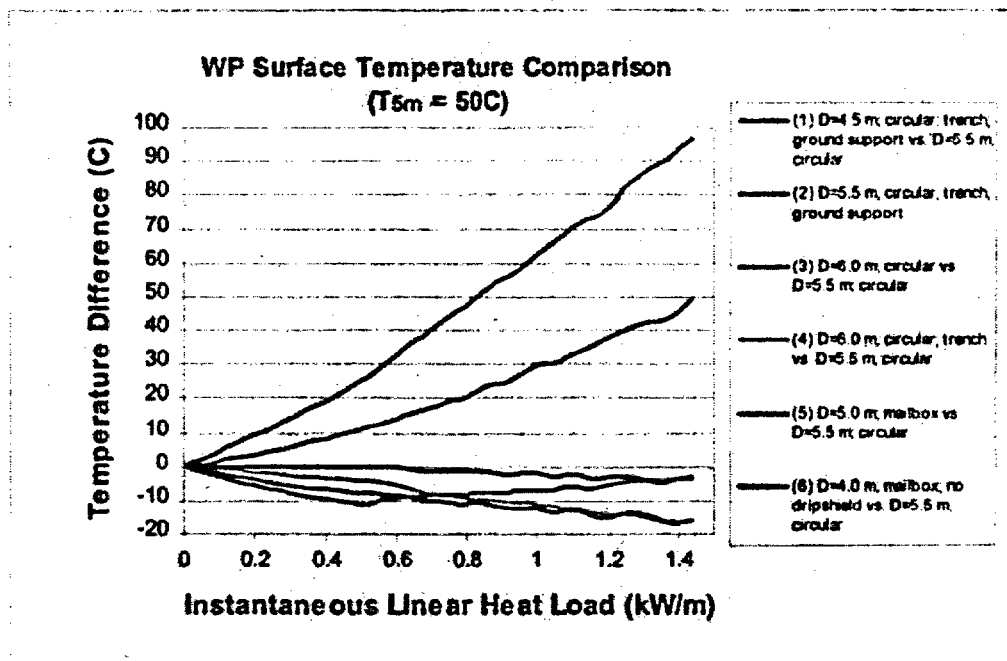

Figure 6-7. Waste Package Surface Temperature Comparison with SR Baseline Design ( $T_{sm}=50^{\circ}\text{C}$ )

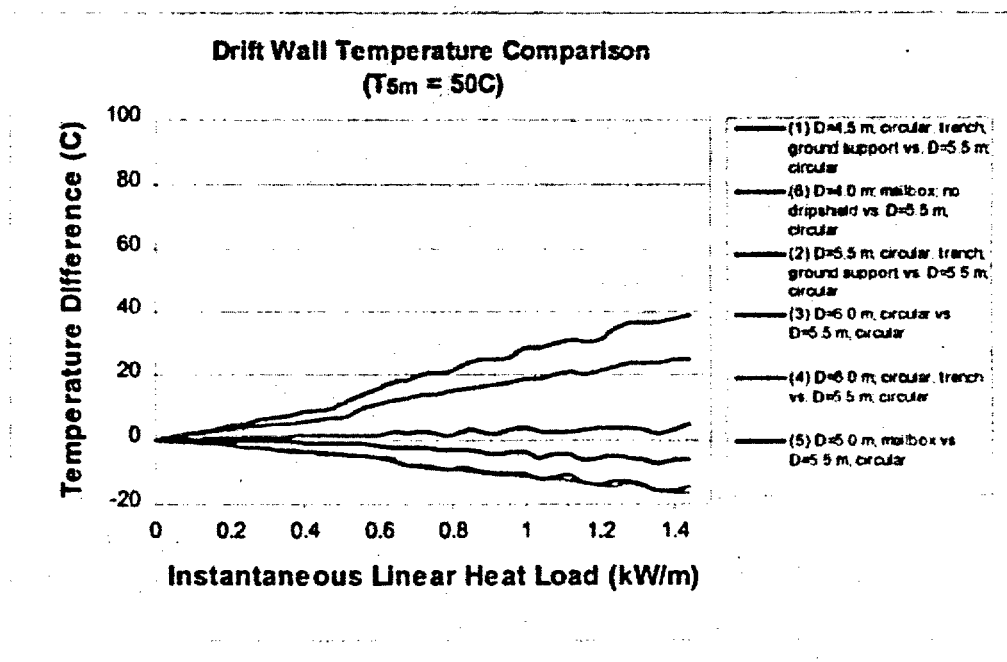

Figure 6-8. Drift Wall Temperature Comparison with SR Baseline Design ( $T_{sm}=50^{\circ}\text{C}$ )

Originator: HM Date: 5/29/02

Checker: MLL Date: 5/29/02

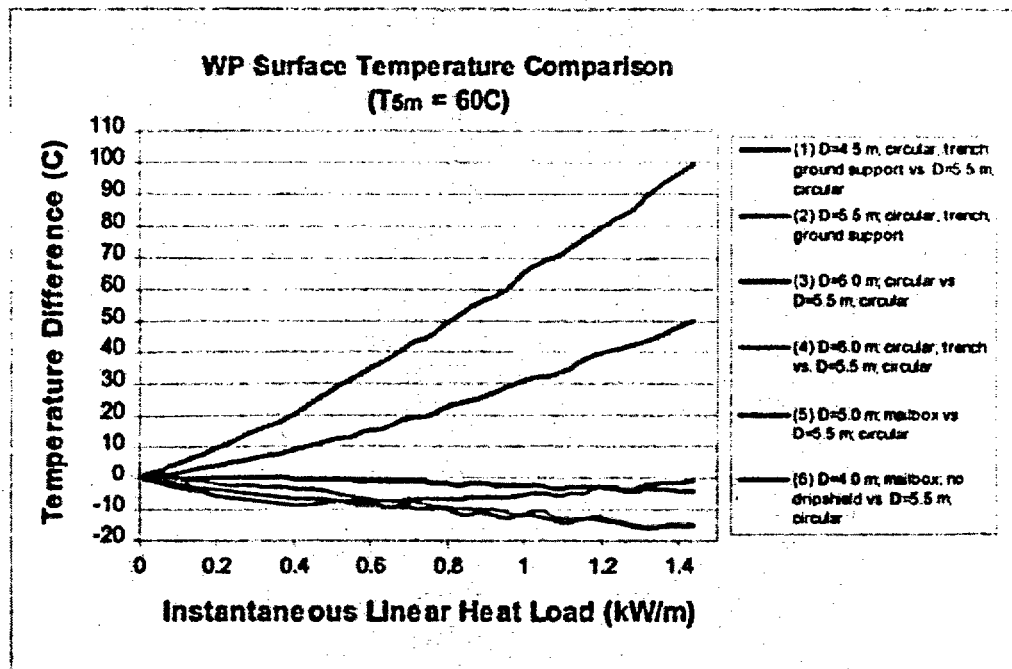

Figure 6-9. Waste Package Surface Temperature Comparison with SR Baseline Design ( $T_{sm}=60^{\circ}C$ )

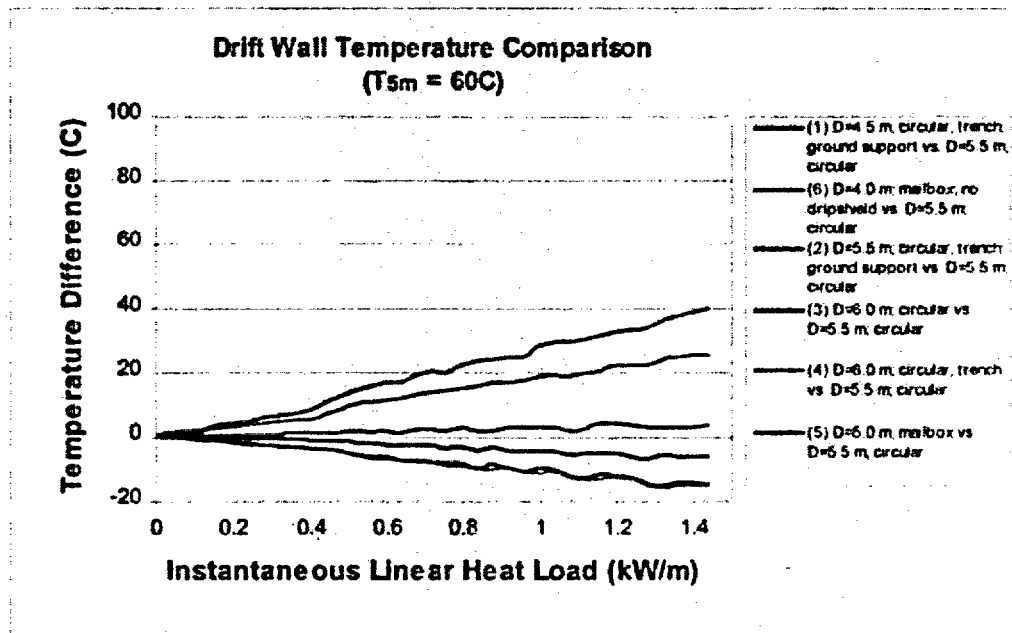

Figure 6-10. Drift Wall Temperature Comparison with SR Baseline Design ( $T_{sm}=60^{\circ}C$ )

Originator: HM Date: 5/29/02

Checker: MH Date: 5/29/02



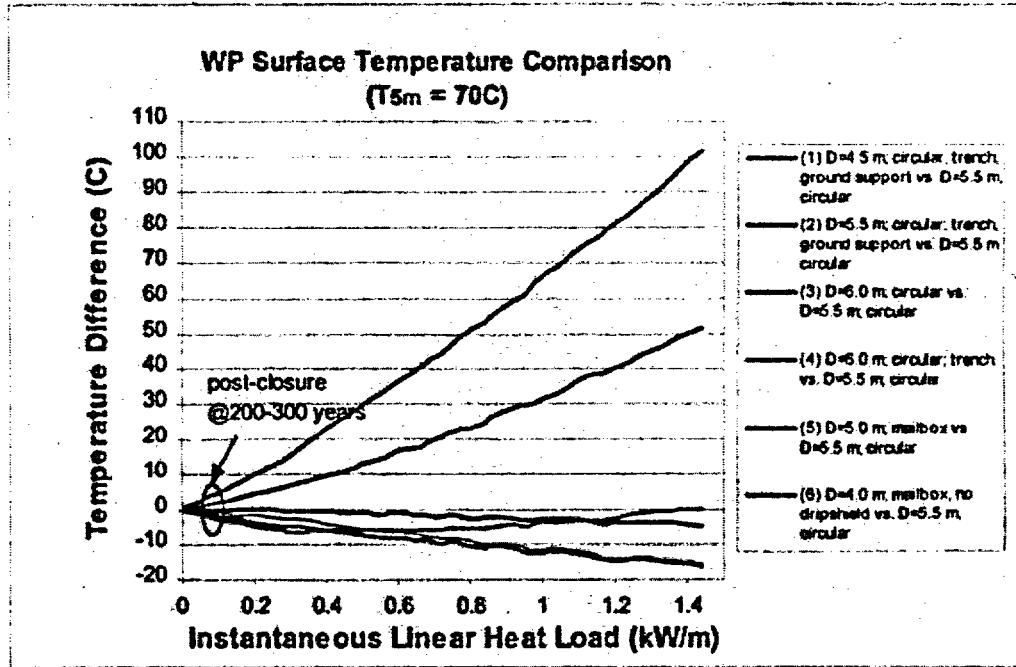

Figure 6-11. Waste Package Surface Temperature Comparison with SR Baseline Design ( $T_{sm}=70^{\circ}C$ )

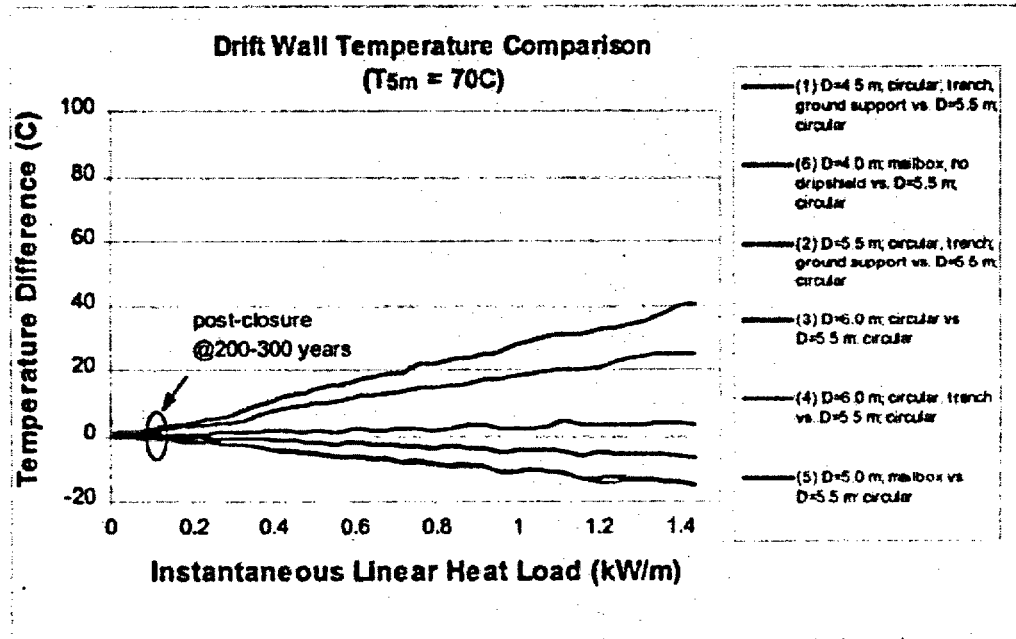

Figure 6-12. Drift Wall Temperature Comparison with SR Baseline Design ( $T_{sm}=70^{\circ}C$ )

Originator: HM Date: 5/29/02

Checker: MH Date: 5/27/02

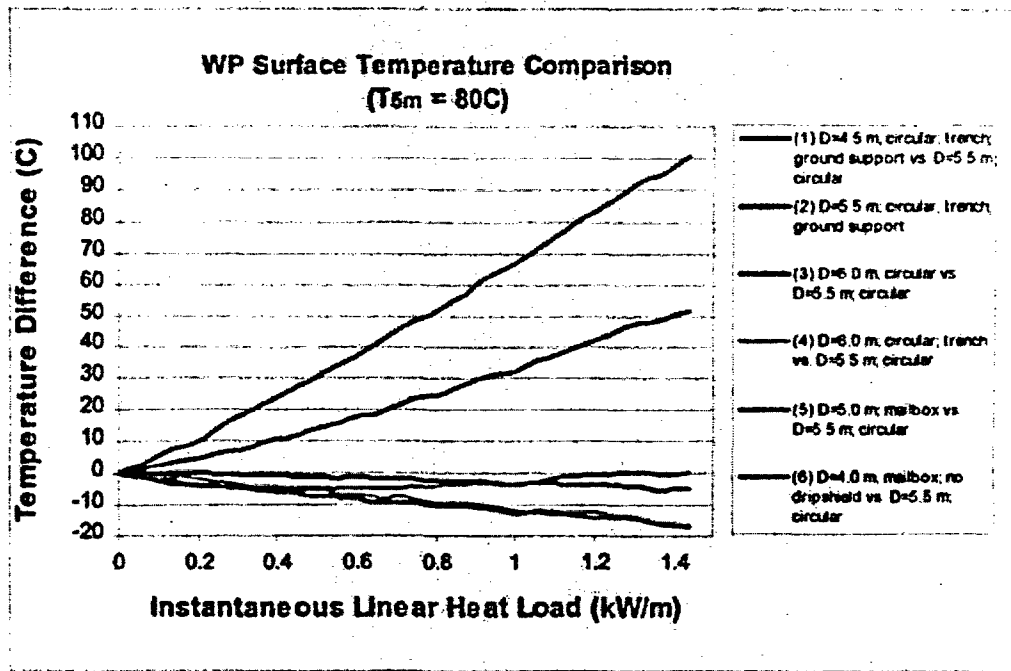

Figure 6-13. Waste Package Surface Temperature Comparison with SR Baseline Design ( $T_{sm}=80^{\circ}C$ )

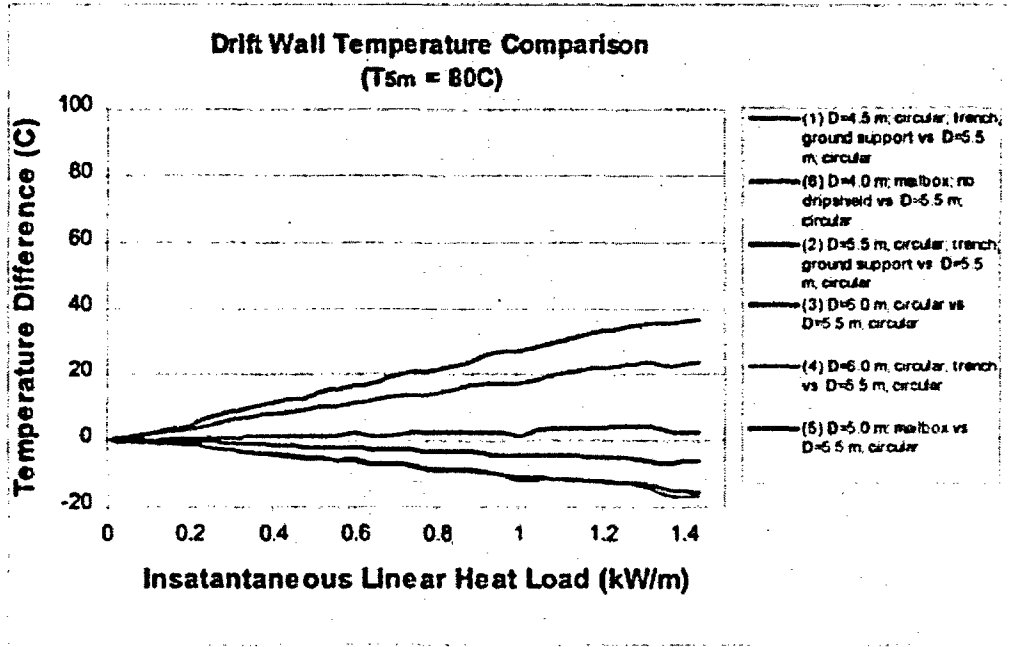

Figure 6-14. Drift Wall Temperature Comparison with SR Baseline Design ( $T_{sm}=80^{\circ}C$ )

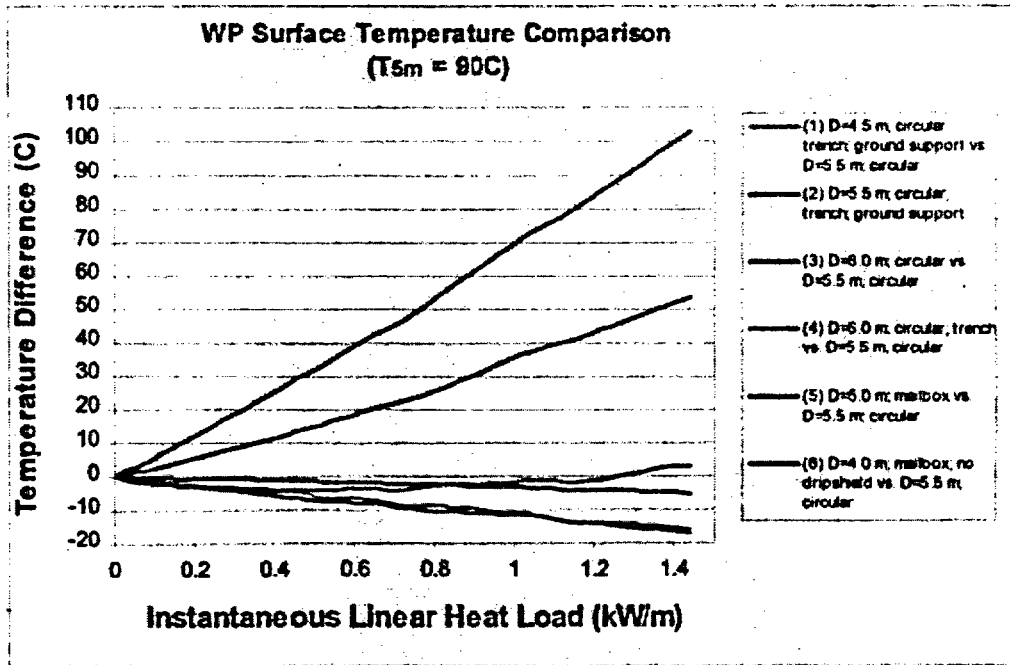

Figure 6-15. Waste Package Surface Temperature Comparison with SR Baseline Design ( $T_{sm}=90^{\circ}C$ )

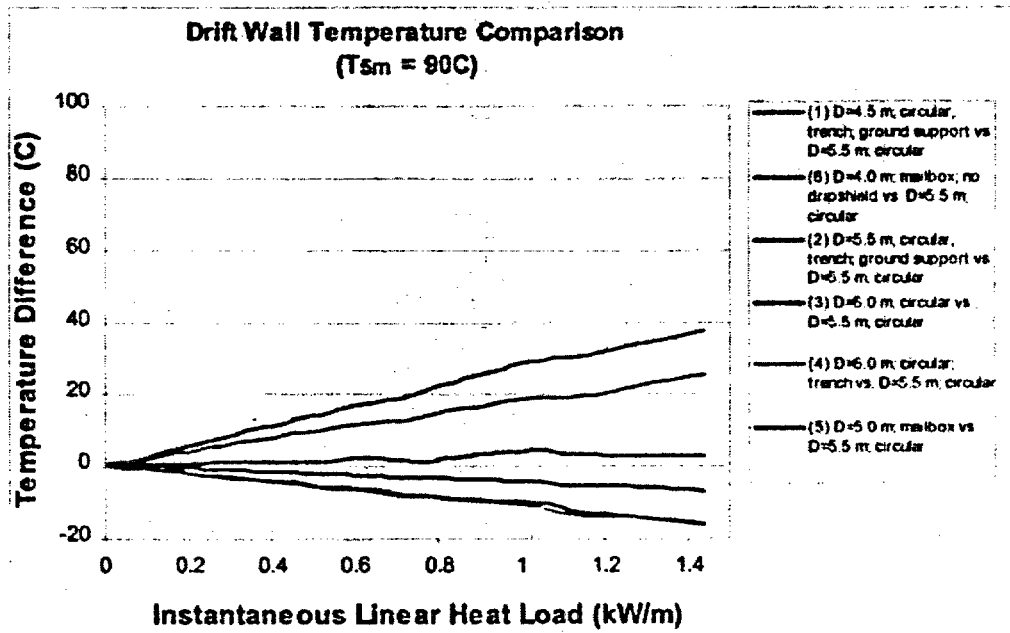
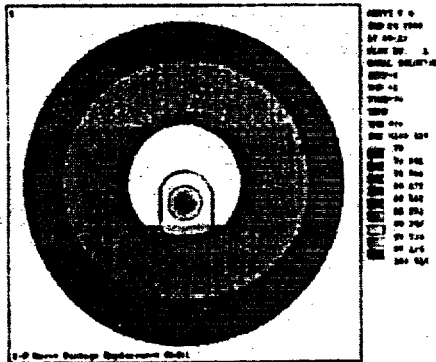

Figure 6-16. Drift Wall Temperature Comparison with SR Baseline Design ( $T_{sm}=90^{\circ}C$ )

Originator: HM Date: 5/29/02

Checker: MH Date: 5/29/02

SR Baseline Case:



Case 1:

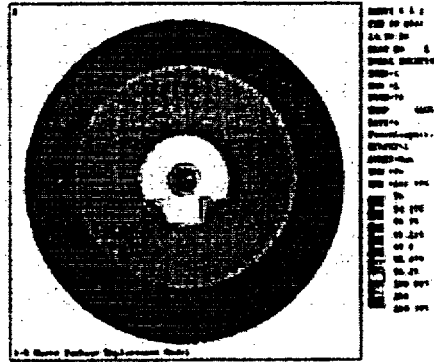

Case 2:

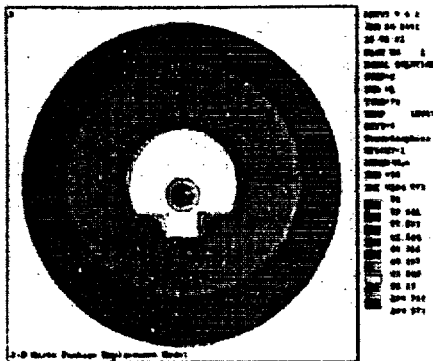

Case 3:

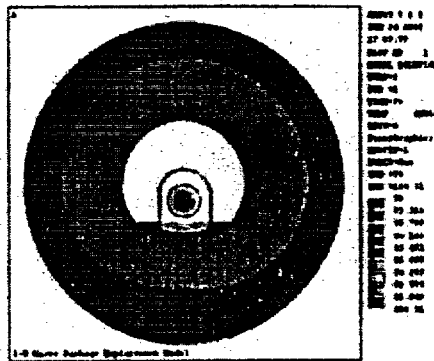

Case 4:

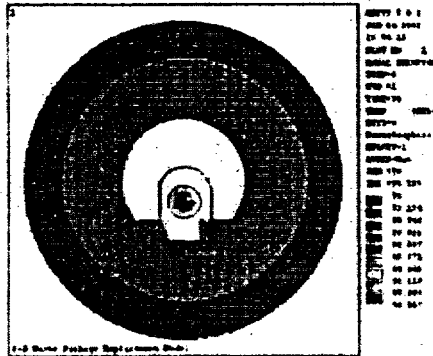

Case 5:

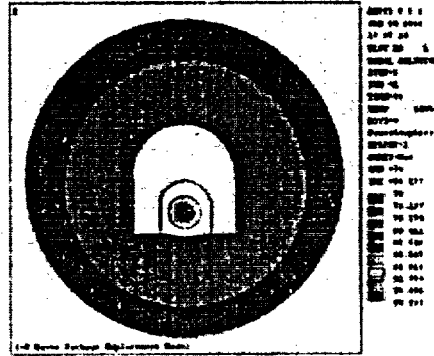

Case 6:

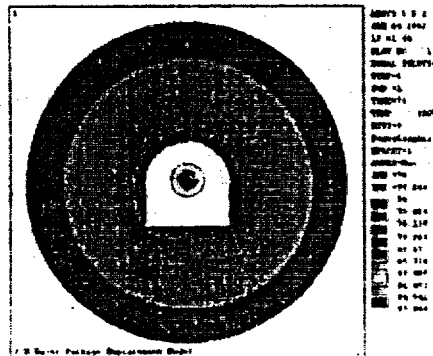

Figure 6-17. Temperature Contours ( $T_{5m} = 70^{\circ}C$ )

Originator: Hm Date: 5/29/02

Checker: ML Date: 5/29/02

### 6.3 RESULTS OF DRIFT DIAMETER EFFECT

Tables 6-9 through 6-12 list the waste package surface temperature differences due to the change in diameter from that of a 21 PWR waste package. Figures 6-18 through 6-26 graphically present the comparison (for drift wall temperatures of 20°C to 90°C and 200°C).

The results show that waste package surface temperature increases with decreasing of the waste package diameter. For the same linear heat load, the higher the drift wall temperature, the smaller the waste package surface temperature difference with changing of the waste package diameter.

Figure 6-23 shows the drift wall temperature condition at 70°C. This boundary condition is similar to that of post-closure at 200-300 years (Ref. 3, Figures 6-4 and 6-5). The instantaneous linear heat load for a 2-m waste package spacing at these times is about 0.12-0.15 kW/m. Therefore the waste package surface temperature difference for all the waste package sizes compared to that of the 21 PWR is insignificant.

Originator: HM Date: 5/29/02

Checker: MH Date: 5/29/02

Table 6-9. Waste Package Surface Temperature Comparison (D = 1 m vs. D = 1.564 m)

Linear Heat Load (kW/m)	Waste Package Surface Temperature Difference (D = 1 m vs. D = 1.564 m) (°C)																						
	0.01	0.02	0.03	0.04	0.05	0.06	0.07	0.08	0.09	0.1	0.2	0.3	0.4	0.5	0.6	0.7	0.8	0.9	1	1.1	1.2	1.3	1.45
Tdrift (°C)																							
20	0.2	0.5	0.7	0.9	1.1	1.3	1.6	1.8	2.0	2.2	4.2	6.0	7.6	9.2	10.6	11.9	13.1	14.3	15.4	16.4	17.3	18.3	19.6
30	0.2	0.4	0.6	0.8	1.0	1.2	1.4	1.6	1.8	2.0	3.8	5.5	7.1	8.5	9.8	11.1	12.3	13.4	14.5	15.5	16.4	17.3	18.6
40	0.2	0.4	0.6	0.7	0.9	1.1	1.3	1.5	1.6	1.8	3.5	5.1	6.5	7.9	9.2	10.4	11.5	12.6	13.6	14.6	15.5	16.4	17.6
50	0.2	0.3	0.5	0.7	0.8	1.0	1.2	1.3	1.5	1.7	3.2	4.7	6.0	7.3	8.5	9.7	10.8	11.8	12.8	13.7	14.6	15.5	16.7
60	0.2	0.3	0.5	0.6	0.8	0.9	1.1	1.2	1.4	1.5	3.0	4.3	5.6	6.8	7.9	9.0	10.1	11.1	12.0	12.9	13.8	14.6	15.8
70	0.1	0.3	0.4	0.6	0.7	0.8	1.0	1.1	1.3	1.4	2.7	4.0	5.2	6.3	7.4	8.4	9.4	10.4	11.3	12.1	13.0	13.8	15.0
80	0.1	0.3	0.4	0.5	0.7	0.8	0.9	1.0	1.2	1.3	2.5	3.7	4.8	5.9	6.9	7.9	8.8	9.7	10.6	11.4	12.2	13.0	14.1
90	0.1	0.2	0.4	0.5	0.6	0.7	0.8	1.0	1.1	1.2	2.3	3.4	4.5	5.5	6.4	7.3	8.2	9.1	9.9	10.7	11.5	12.3	13.4
100	0.1	0.2	0.3	0.4	0.6	0.7	0.8	0.9	1.0	1.1	2.2	3.2	4.1	5.1	6.0	6.9	7.7	8.5	9.3	10.1	10.8	11.6	12.6
110	0.1	0.2	0.3	0.4	0.5	0.6	0.7	0.8	0.9	1.0	2.0	2.9	3.9	4.7	5.6	6.4	7.2	8.0	8.8	9.5	10.2	10.9	11.9
120	0.1	0.2	0.3	0.4	0.5	0.6	0.7	0.8	0.8	0.9	1.9	2.7	3.6	4.4	5.2	6.0	6.8	7.5	8.2	8.9	9.6	10.3	11.2
130	0.1	0.2	0.3	0.4	0.4	0.5	0.6	0.7	0.8	0.9	1.7	2.5	3.4	4.1	4.9	5.6	6.3	7.0	7.7	8.4	9.1	9.7	10.6
140	0.1	0.2	0.2	0.3	0.4	0.5	0.6	0.7	0.7	0.8	1.6	2.4	3.1	3.9	4.6	5.3	6.0	6.6	7.3	7.9	8.5	9.1	10.0
150	0.1	0.2	0.2	0.3	0.4	0.5	0.5	0.6	0.7	0.8	1.5	2.2	2.9	3.6	4.3	4.9	5.6	6.2	6.8	7.4	8.0	8.6	9.5
160	0.1	0.1	0.2	0.3	0.4	0.4	0.5	0.6	0.6	0.7	1.4	2.1	2.7	3.4	4.0	4.6	5.3	5.9	6.4	7.0	7.6	8.1	8.9
170	0.1	0.1	0.2	0.3	0.3	0.4	0.5	0.5	0.6	0.7	1.3	1.9	2.6	3.2	3.8	4.4	4.9	5.5	6.1	6.6	7.1	7.7	8.4
180	0.1	0.1	0.2	0.2	0.3	0.4	0.4	0.5	0.6	0.6	1.2	1.8	2.4	3.0	3.6	4.1	4.7	5.2	5.7	6.2	6.7	7.2	8.0
190	0.1	0.1	0.2	0.2	0.3	0.3	0.4	0.5	0.5	0.6	1.2	1.7	2.3	2.8	3.3	3.9	4.4	4.9	5.4	5.9	6.4	6.9	7.6
200	0.1	0.1	0.2	0.2	0.3	0.3	0.4	0.4	0.5	0.5	1.1	1.6	2.1	2.6	3.1	3.6	4.1	4.6	5.1	5.6	6.0	6.5	7.1
210	0.1	0.1	0.2	0.2	0.3	0.3	0.4	0.4	0.5	0.5	1.0	1.5	2.0	2.5	3.0	3.4	3.9	4.4	4.8	5.3	5.7	6.1	6.8
220	0.0	0.1	0.1	0.2	0.2	0.3	0.3	0.4	0.4	0.5	1.0	1.4	1.9	2.3	2.8	3.2	3.7	4.1	4.5	5.0	5.4	5.8	6.4
230	0.0	0.1	0.1	0.2	0.2	0.3	0.3	0.4	0.4	0.5	0.9	1.3	1.8	2.2	2.6	3.1	3.5	3.9	4.3	4.7	5.1	5.5	6.1
240	0.0	0.1	0.1	0.2	0.2	0.3	0.3	0.3	0.4	0.4	0.9	1.3	1.7	2.1	2.5	2.9	3.3	3.7	4.1	4.5	4.8	5.2	5.8
250	0.0	0.1	0.1	0.2	0.2	0.2	0.3	0.3	0.4	0.4	0.8	1.2	1.6	2.0	2.4	2.7	3.1	3.5	3.9	4.2	4.6	4.9	5.5
260	0.0	0.1	0.1	0.2	0.2	0.2	0.3	0.3	0.3	0.4	0.8	1.1	1.5	1.9	2.2	2.6	3.0	3.3	3.7	4.0	4.4	4.7	5.2
270	0.0	0.1	0.1	0.1	0.2	0.2	0.3	0.3	0.3	0.4	0.7	1.1	1.4	1.8	2.1	2.5	2.8	3.1	3.5	3.8	4.1	4.5	4.9
280	0.0	0.1	0.1	0.1	0.2	0.2	0.2	0.3	0.3	0.3	0.7	1.0	1.4	1.7	2.0	2.3	2.7	3.0	3.3	3.6	3.9	4.2	4.7
290	0.0	0.1	0.1	0.1	0.2	0.2	0.2	0.3	0.3	0.3	0.6	1.0	1.3	1.6	1.9	2.2	2.5	2.8	3.1	3.4	3.7	4.0	4.5
300	0.0	0.1	0.1	0.1	0.2	0.2	0.2	0.2	0.3	0.3	0.6	0.9	1.2	1.5	1.8	2.1	2.4	2.7	3.0	3.3	3.6	3.8	4.3

Originator: HM Date: 5/29/02

Checker: MH Date: 5/29/02

Table 6-10. Waste Package Surface Temperature Comparison (D = 1.5 m vs. D = 1.564 m)

Linear Heat Load (kW/m)	Waste Package Surface Temperature Difference (D = 1.5 m vs. D = 1.564 m) (°C)																						
	0.01	0.02	0.03	0.04	0.05	0.06	0.07	0.08	0.09	0.1	0.2	0.3	0.4	0.5	0.6	0.7	0.8	0.9	1	1.1	1.2	1.3	1.45
Tdrift (°C)																							
20	0.0	0.0	0.1	0.1	0.1	0.1	0.1	0.1	0.2	0.2	0.3	0.5	0.6	0.7	0.8	0.9	1.0	1.1	1.2	1.3	1.4	1.5	1.6
30	0.0	0.0	0.0	0.1	0.1	0.1	0.1	0.1	0.1	0.2	0.3	0.4	0.6	0.7	0.8	0.9	1.0	1.1	1.2	1.2	1.3	1.4	1.5
40	0.0	0.0	0.0	0.1	0.1	0.1	0.1	0.1	0.1	0.1	0.3	0.4	0.5	0.6	0.7	0.8	0.9	1.0	1.1	1.2	1.2	1.3	1.4
50	0.0	0.0	0.0	0.1	0.1	0.1	0.1	0.1	0.1	0.1	0.2	0.4	0.5	0.6	0.7	0.8	0.8	0.9	1.0	1.1	1.2	1.2	1.3
60	0.0	0.0	0.0	0.0	0.1	0.1	0.1	0.1	0.1	0.1	0.2	0.3	0.4	0.5	0.6	0.7	0.8	0.9	1.0	1.0	1.1	1.2	1.3
70	0.0	0.0	0.0	0.0	0.1	0.1	0.1	0.1	0.1	0.1	0.2	0.3	0.4	0.5	0.6	0.7	0.7	0.8	0.9	1.0	1.0	1.1	1.2
80	0.0	0.0	0.0	0.0	0.0	0.1	0.1	0.1	0.1	0.1	0.2	0.3	0.4	0.5	0.5	0.6	0.7	0.8	0.8	0.9	1.0	1.0	1.1
90	0.0	0.0	0.0	0.0	0.0	0.1	0.1	0.1	0.1	0.1	0.2	0.3	0.3	0.4	0.5	0.6	0.6	0.7	0.8	0.8	0.9	1.0	1.1
100	0.0	0.0	0.0	0.0	0.0	0.1	0.1	0.1	0.1	0.1	0.2	0.2	0.3	0.4	0.5	0.5	0.6	0.7	0.7	0.8	0.9	0.9	1.0
110	0.0	0.0	0.0	0.0	0.0	0.0	0.1	0.1	0.1	0.1	0.2	0.2	0.3	0.4	0.4	0.5	0.6	0.6	0.7	0.7	0.8	0.9	0.9
120	0.0	0.0	0.0	0.0	0.0	0.0	0.1	0.1	0.1	0.1	0.1	0.2	0.3	0.3	0.4	0.5	0.5	0.6	0.6	0.7	0.8	0.8	0.9
130	0.0	0.0	0.0	0.0	0.0	0.0	0.0	0.1	0.1	0.1	0.1	0.2	0.3	0.3	0.4	0.4	0.5	0.5	0.6	0.7	0.7	0.8	0.8
140	0.0	0.0	0.0	0.0	0.0	0.0	0.0	0.0	0.1	0.1	0.1	0.2	0.2	0.3	0.4	0.4	0.5	0.5	0.6	0.6	0.7	0.7	0.8
150	0.0	0.0	0.0	0.0	0.0	0.0	0.0	0.0	0.1	0.1	0.1	0.2	0.2	0.3	0.3	0.4	0.4	0.5	0.5	0.6	0.6	0.7	0.7
160	0.0	0.0	0.0	0.0	0.0	0.0	0.0	0.0	0.0	0.1	0.1	0.2	0.2	0.3	0.3	0.4	0.4	0.5	0.5	0.6	0.6	0.7	0.7
170	0.0	0.0	0.0	0.0	0.0	0.0	0.0	0.0	0.0	0.1	0.1	0.1	0.2	0.2	0.3	0.3	0.4	0.4	0.5	0.5	0.6	0.6	0.7
180	0.0	0.0	0.0	0.0	0.0	0.0	0.0	0.0	0.0	0.0	0.1	0.1	0.2	0.2	0.3	0.3	0.4	0.4	0.4	0.5	0.5	0.6	0.6
190	0.0	0.0	0.0	0.0	0.0	0.0	0.0	0.0	0.0	0.0	0.1	0.1	0.2	0.2	0.3	0.3	0.3	0.4	0.4	0.5	0.5	0.5	0.6
200	0.0	0.0	0.0	0.0	0.0	0.0	0.0	0.0	0.0	0.0	0.1	0.1	0.2	0.2	0.2	0.3	0.3	0.4	0.4	0.4	0.5	0.5	0.6
210	0.0	0.0	0.0	0.0	0.0	0.0	0.0	0.0	0.0	0.0	0.1	0.1	0.2	0.2	0.2	0.3	0.3	0.3	0.4	0.4	0.4	0.5	0.5
220	0.0	0.0	0.0	0.0	0.0	0.0	0.0	0.0	0.0	0.0	0.1	0.1	0.1	0.2	0.2	0.2	0.3	0.3	0.3	0.4	0.4	0.4	0.5
230	0.0	0.0	0.0	0.0	0.0	0.0	0.0	0.0	0.0	0.0	0.1	0.1	0.1	0.2	0.2	0.2	0.3	0.3	0.3	0.4	0.4	0.4	0.5
240	0.0	0.0	0.0	0.0	0.0	0.0	0.0	0.0	0.0	0.0	0.1	0.1	0.1	0.2	0.2	0.2	0.3	0.3	0.3	0.3	0.4	0.4	0.4
250	0.0	0.0	0.0	0.0	0.0	0.0	0.0	0.0	0.0	0.0	0.1	0.1	0.1	0.2	0.2	0.2	0.2	0.3	0.3	0.3	0.4	0.4	0.4
260	0.0	0.0	0.0	0.0	0.0	0.0	0.0	0.0	0.0	0.0	0.1	0.1	0.1	0.1	0.2	0.2	0.2	0.3	0.3	0.3	0.3	0.4	0.4
270	0.0	0.0	0.0	0.0	0.0	0.0	0.0	0.0	0.0	0.0	0.1	0.1	0.1	0.1	0.2	0.2	0.2	0.2	0.3	0.3	0.3	0.3	0.4
280	0.0	0.0	0.0	0.0	0.0	0.0	0.0	0.0	0.0	0.0	0.1	0.1	0.1	0.1	0.2	0.2	0.2	0.2	0.3	0.3	0.3	0.3	0.4
290	0.0	0.0	0.0	0.0	0.0	0.0	0.0	0.0	0.0	0.0	0.0	0.1	0.1	0.1	0.1	0.2	0.2	0.2	0.2	0.3	0.3	0.3	0.3
300	0.0	0.0	0.0	0.0	0.0	0.0	0.0	0.0	0.0	0.0	0.0	0.1	0.1	0.1	0.1	0.2	0.2	0.2	0.2	0.2	0.3	0.3	0.3

Originator: HM Date: 5/29/02

Checker: MH Date: 5/29/02

Table 6-11. Waste Package Surface Temperature Comparison (D = 2 m vs. D = 1.564 m)

Linear Heat Load (kW/m)	Waste Package Surface Temperature Difference (D = 2 m vs. D = 1.564 m) (°C)																						
	0.01	0.02	0.03	0.04	0.05	0.06	0.07	0.08	0.09	0.1	0.2	0.3	0.4	0.5	0.6	0.7	0.8	0.9	1	1.1	1.2	1.3	1.45
Tdrift (°C)																							
20	-0.1	-0.2	-0.3	-0.4	-0.4	-0.5	-0.6	-0.7	-0.8	-0.9	-1.7	-2.4	-3.1	-3.8	-4.4	-5.0	-5.5	-6.1	-6.6	-7.0	-7.5	-7.9	-8.6
30	-0.1	-0.2	-0.2	-0.3	-0.4	-0.5	-0.6	-0.6	-0.7	-0.8	-1.5	-2.2	-2.9	-3.5	-4.1	-4.6	-5.1	-5.6	-6.1	-6.6	-7.0	-7.5	-8.1
40	-0.1	-0.1	-0.2	-0.3	-0.4	-0.4	-0.5	-0.6	-0.6	-0.7	-1.4	-2.0	-2.6	-3.2	-3.8	-4.3	-4.8	-5.3	-5.7	-6.2	-6.6	-7.0	-7.6
50	-0.1	-0.1	-0.2	-0.3	-0.3	-0.4	-0.5	-0.5	-0.6	-0.6	-1.3	-1.9	-2.4	-3.0	-3.5	-4.0	-4.4	-4.9	-5.3	-5.8	-6.2	-6.6	-7.1
60	-0.1	-0.1	-0.2	-0.2	-0.3	-0.4	-0.4	-0.5	-0.5	-0.6	-1.2	-1.7	-2.2	-2.7	-3.2	-3.7	-4.1	-4.6	-5.0	-5.4	-5.8	-6.2	-6.7
70	-0.1	-0.1	-0.2	-0.2	-0.3	-0.3	-0.4	-0.4	-0.5	-0.5	-1.1	-1.6	-2.1	-2.5	-3.0	-3.4	-3.8	-4.3	-4.7	-5.0	-5.4	-5.8	-6.3
80	-0.1	-0.1	-0.2	-0.2	-0.3	-0.3	-0.4	-0.4	-0.5	-0.5	-1.0	-1.5	-1.9	-2.3	-2.8	-3.2	-3.6	-4.0	-4.3	-4.7	-5.1	-5.4	-5.9
90	0.0	-0.1	-0.1	-0.2	-0.2	-0.3	-0.3	-0.4	-0.4	-0.5	-0.9	-1.3	-1.8	-2.2	-2.6	-3.0	-3.3	-3.7	-4.1	-4.4	-4.7	-5.1	-5.6
100	0.0	-0.1	-0.1	-0.2	-0.2	-0.3	-0.3	-0.3	-0.4	-0.4	-0.8	-1.2	-1.6	-2.0	-2.4	-2.8	-3.1	-3.5	-3.8	-4.1	-4.4	-4.8	-5.2
110	0.0	-0.1	-0.1	-0.2	-0.2	-0.2	-0.3	-0.3	-0.4	-0.4	-0.8	-1.2	-1.5	-1.9	-2.2	-2.6	-2.9	-3.2	-3.5	-3.9	-4.2	-4.5	-4.9
120	0.0	-0.1	-0.1	-0.1	-0.2	-0.2	-0.3	-0.3	-0.3	-0.4	-0.7	-1.1	-1.4	-1.7	-2.1	-2.4	-2.7	-3.0	-3.3	-3.6	-3.9	-4.2	-4.6
130	0.0	-0.1	-0.1	-0.1	-0.2	-0.2	-0.2	-0.3	-0.3	-0.3	-0.7	-1.0	-1.3	-1.6	-1.9	-2.2	-2.5	-2.8	-3.1	-3.4	-3.7	-3.9	-4.3
140	0.0	-0.1	-0.1	-0.1	-0.2	-0.2	-0.2	-0.3	-0.3	-0.3	-0.6	-0.9	-1.2	-1.5	-1.8	-2.1	-2.4	-2.6	-2.9	-3.2	-3.4	-3.7	-4.1
150	0.0	-0.1	-0.1	-0.1	-0.1	-0.2	-0.2	-0.2	-0.3	-0.3	-0.6	-0.9	-1.1	-1.4	-1.7	-2.0	-2.2	-2.5	-2.7	-3.0	-3.2	-3.5	-3.8
160	0.0	-0.1	-0.1	-0.1	-0.1	-0.2	-0.2	-0.2	-0.2	-0.3	-0.5	-0.8	-1.1	-1.3	-1.6	-1.8	-2.1	-2.3	-2.6	-2.8	-3.0	-3.3	-3.6
170	0.0	-0.1	-0.1	-0.1	-0.1	-0.2	-0.2	-0.2	-0.2	-0.3	-0.5	-0.8	-1.0	-1.2	-1.5	-1.7	-2.0	-2.2	-2.4	-2.6	-2.9	-3.1	-3.4
180	0.0	0.0	-0.1	-0.1	-0.1	-0.1	-0.2	-0.2	-0.2	-0.2	-0.5	-0.7	-0.9	-1.2	-1.4	-1.6	-1.8	-2.1	-2.3	-2.5	-2.7	-2.9	-3.2
190	0.0	0.0	-0.1	-0.1	-0.1	-0.1	-0.2	-0.2	-0.2	-0.2	-0.4	-0.7	-0.9	-1.1	-1.3	-1.5	-1.7	-1.9	-2.1	-2.3	-2.5	-2.7	-3.0
200	0.0	0.0	-0.1	-0.1	-0.1	-0.1	-0.1	-0.2	-0.2	-0.2	-0.4	-0.6	-0.8	-1.0	-1.2	-1.4	-1.6	-1.8	-2.0	-2.2	-2.4	-2.6	-2.8
210	0.0	0.0	-0.1	-0.1	-0.1	-0.1	-0.1	-0.2	-0.2	-0.2	-0.4	-0.6	-0.8	-1.0	-1.2	-1.3	-1.5	-1.7	-1.9	-2.1	-2.3	-2.4	-2.7
220	0.0	0.0	-0.1	-0.1	-0.1	-0.1	-0.1	-0.1	-0.2	-0.2	-0.4	-0.6	-0.7	-0.9	-1.1	-1.3	-1.4	-1.6	-1.8	-2.0	-2.1	-2.3	-2.5
230	0.0	0.0	-0.1	-0.1	-0.1	-0.1	-0.1	-0.1	-0.2	-0.2	-0.4	-0.5	-0.7	-0.9	-1.0	-1.2	-1.4	-1.5	-1.7	-1.9	-2.0	-2.2	-2.4
240	0.0	0.0	0.0	-0.1	-0.1	-0.1	-0.1	-0.1	-0.1	-0.2	-0.3	-0.5	-0.7	-0.8	-1.0	-1.1	-1.3	-1.4	-1.6	-1.8	-1.9	-2.1	-2.3
250	0.0	0.0	0.0	-0.1	-0.1	-0.1	-0.1	-0.1	-0.1	-0.2	-0.3	-0.5	-0.6	-0.8	-0.9	-1.1	-1.2	-1.4	-1.5	-1.7	-1.8	-1.9	-2.2
260	0.0	0.0	0.0	-0.1	-0.1	-0.1	-0.1	-0.1	-0.1	-0.1	-0.3	-0.4	-0.6	-0.7	-0.9	-1.0	-1.2	-1.3	-1.4	-1.6	-1.7	-1.8	-2.0
270	0.0	0.0	0.0	-0.1	-0.1	-0.1	-0.1	-0.1	-0.1	-0.1	-0.3	-0.4	-0.6	-0.7	-0.8	-1.0	-1.1	-1.2	-1.4	-1.5	-1.6	-1.8	-1.9
280	0.0	0.0	0.0	-0.1	-0.1	-0.1	-0.1	-0.1	-0.1	-0.1	-0.3	-0.4	-0.5	-0.7	-0.8	-0.9	-1.0	-1.2	-1.3	-1.4	-1.5	-1.7	-1.8
290	0.0	0.0	0.0	-0.1	-0.1	-0.1	-0.1	-0.1	-0.1	-0.1	-0.3	-0.4	-0.5	-0.6	-0.7	-0.9	-1.0	-1.1	-1.2	-1.3	-1.5	-1.6	-1.8
300	0.0	0.0	0.0	0.0	-0.1	-0.1	-0.1	-0.1	-0.1	-0.1	-0.2	-0.4	-0.5	-0.6	-0.7	-0.8	-0.9	-1.1	-1.2	-1.3	-1.4	-1.5	-1.7

Originator: HM Date: 5/29/02

Checker: MH Date: 5/29/02



Table 6-12. Waste Package Surface Temperature Comparison (D = 2.5 m vs. D = 1.564 m)

Linear Heat Load (kW/m) Tdrift (°C)	Waste Package Surface Temperature Difference (D = 2.5 m vs. D = 1.564 m) (°C)																						
	0.01	0.02	0.03	0.04	0.05	0.06	0.07	0.08	0.09	0.1	0.2	0.3	0.4	0.5	0.6	0.7	0.8	0.9	1	1.1	1.2	1.3	1.45
20	-0.2	-0.3	-0.5	-0.6	-0.8	-0.9	-1.0	-1.2	-1.3	-1.5	-2.9	-4.2	-5.4	-6.6	-7.7	-8.7	-9.7	-10.6	-11.5	-12.4	-13.2	-14.0	-15.1
30	-0.1	-0.3	-0.4	-0.5	-0.7	-0.8	-1.0	-1.1	-1.2	-1.3	-2.6	-3.8	-5.0	-6.0	-7.1	-8.0	-9.0	-9.9	-10.7	-11.8	-12.4	-13.1	-14.2
40	-0.1	-0.3	-0.4	-0.5	-0.6	-0.7	-0.9	-1.0	-1.1	-1.2	-2.4	-3.5	-4.6	-5.6	-6.5	-7.5	-8.3	-9.2	-10.0	-10.8	-11.6	-12.3	-13.3
50	-0.1	-0.2	-0.3	-0.5	-0.6	-0.7	-0.8	-0.9	-1.0	-1.1	-2.2	-3.2	-4.2	-5.1	-6.0	-6.9	-7.7	-8.5	-9.3	-10.1	-10.8	-11.5	-12.5
60	-0.1	-0.2	-0.3	-0.4	-0.5	-0.6	-0.7	-0.8	-0.9	-1.0	-2.0	-3.0	-3.9	-4.7	-5.6	-6.4	-7.2	-8.0	-8.7	-9.4	-10.1	-10.8	-11.7
70	-0.1	-0.2	-0.3	-0.4	-0.5	-0.6	-0.7	-0.8	-0.8	-0.9	-1.8	-2.7	-3.6	-4.4	-5.2	-5.9	-6.7	-7.4	-8.1	-8.8	-9.4	-10.1	-11.0
80	-0.1	-0.2	-0.3	-0.3	-0.4	-0.5	-0.6	-0.7	-0.8	-0.9	-1.7	-2.5	-3.3	-4.1	-4.8	-5.5	-6.2	-6.9	-7.6	-8.2	-8.8	-9.4	-10.3
90	-0.1	-0.2	-0.2	-0.3	-0.4	-0.5	-0.6	-0.6	-0.7	-0.8	-1.6	-2.3	-3.0	-3.8	-4.5	-5.1	-5.8	-6.4	-7.0	-7.7	-8.3	-8.8	-9.7
100	-0.1	-0.1	-0.2	-0.3	-0.4	-0.4	-0.5	-0.6	-0.7	-0.7	-1.4	-2.1	-2.8	-3.5	-4.1	-4.8	-5.4	-6.0	-6.6	-7.2	-7.7	-8.3	-9.1
110	-0.1	-0.1	-0.2	-0.3	-0.3	-0.4	-0.5	-0.5	-0.6	-0.7	-1.3	-2.0	-2.6	-3.2	-3.8	-4.4	-5.0	-5.6	-6.1	-6.7	-7.2	-7.8	-8.5
120	-0.1	-0.1	-0.2	-0.3	-0.3	-0.4	-0.4	-0.5	-0.6	-0.6	-1.2	-1.8	-2.4	-3.0	-3.6	-4.1	-4.7	-5.2	-5.7	-6.3	-6.8	-7.3	-8.0
130	-0.1	-0.1	-0.2	-0.2	-0.3	-0.4	-0.4	-0.5	-0.5	-0.6	-1.2	-1.7	-2.3	-2.8	-3.3	-3.9	-4.4	-4.9	-5.4	-5.9	-6.3	-6.8	-7.5
140	-0.1	-0.1	-0.2	-0.2	-0.3	-0.3	-0.4	-0.4	-0.5	-0.5	-1.1	-1.6	-2.1	-2.6	-3.1	-3.6	-4.1	-4.6	-5.0	-5.5	-6.0	-6.4	-7.1
150	-0.1	-0.1	-0.2	-0.2	-0.3	-0.3	-0.4	-0.4	-0.5	-0.5	-1.0	-1.5	-2.0	-2.5	-2.9	-3.4	-3.8	-4.3	-4.7	-5.2	-5.6	-6.0	-6.6
160	0.0	-0.1	-0.1	-0.2	-0.2	-0.3	-0.3	-0.4	-0.4	-0.5	-0.9	-1.4	-1.8	-2.3	-2.7	-3.2	-3.6	-4.0	-4.4	-4.8	-5.3	-5.7	-6.2
170	0.0	-0.1	-0.1	-0.2	-0.2	-0.3	-0.3	-0.4	-0.4	-0.4	-0.9	-1.3	-1.7	-2.1	-2.6	-3.0	-3.4	-3.8	-4.2	-4.6	-4.9	-5.3	-5.9
180	0.0	-0.1	-0.1	-0.2	-0.2	-0.2	-0.3	-0.3	-0.4	-0.4	-0.8	-1.2	-1.6	-2.0	-2.4	-2.8	-3.2	-3.5	-3.9	-4.3	-4.6	-5.0	-5.5
190	0.0	-0.1	-0.1	-0.2	-0.2	-0.2	-0.3	-0.3	-0.3	-0.4	-0.8	-1.1	-1.5	-1.9	-2.3	-2.6	-3.0	-3.3	-3.7	-4.0	-4.4	-4.7	-5.2
200	0.0	-0.1	-0.1	-0.1	-0.2	-0.2	-0.3	-0.3	-0.3	-0.4	-0.7	-1.1	-1.4	-1.8	-2.1	-2.5	-2.8	-3.1	-3.5	-3.8	-4.1	-4.4	-4.9
210	0.0	-0.1	-0.1	-0.1	-0.2	-0.2	-0.2	-0.3	-0.3	-0.3	-0.7	-1.0	-1.3	-1.7	-2.0	-2.3	-2.6	-3.0	-3.3	-3.6	-3.9	-4.2	-4.7
220	0.0	-0.1	-0.1	-0.1	-0.2	-0.2	-0.2	-0.3	-0.3	-0.3	-0.6	-1.0	-1.3	-1.6	-1.9	-2.2	-2.5	-2.8	-3.1	-3.4	-3.7	-4.0	-4.4
230	0.0	-0.1	-0.1	-0.1	-0.2	-0.2	-0.2	-0.2	-0.3	-0.3	-0.6	-0.9	-1.2	-1.5	-1.8	-2.1	-2.4	-2.6	-2.9	-3.2	-3.5	-3.7	-4.2
240	0.0	-0.1	-0.1	-0.1	-0.1	-0.2	-0.2	-0.2	-0.3	-0.3	-0.6	-0.8	-1.1	-1.4	-1.7	-2.0	-2.2	-2.5	-2.8	-3.0	-3.3	-3.5	-3.9
250	0.0	-0.1	-0.1	-0.1	-0.1	-0.2	-0.2	-0.2	-0.2	-0.3	-0.5	-0.8	-1.1	-1.3	-1.6	-1.8	-2.1	-2.4	-2.6	-2.9	-3.1	-3.4	-3.7
260	0.0	-0.1	-0.1	-0.1	-0.1	-0.2	-0.2	-0.2	-0.2	-0.3	-0.5	-0.8	-1.0	-1.3	-1.5	-1.7	-2.0	-2.2	-2.5	-2.7	-2.9	-3.2	-3.5
270	0.0	0.0	-0.1	-0.1	-0.1	-0.1	-0.2	-0.2	-0.2	-0.2	-0.5	-0.7	-1.0	-1.2	-1.4	-1.7	-1.9	-2.1	-2.3	-2.6	-2.8	-3.0	-3.4
280	0.0	0.0	-0.1	-0.1	-0.1	-0.1	-0.2	-0.2	-0.2	-0.2	-0.5	-0.7	-0.9	-1.1	-1.3	-1.6	-1.8	-2.0	-2.2	-2.4	-2.7	-2.9	-3.2
290	0.0	0.0	-0.1	-0.1	-0.1	-0.1	-0.2	-0.2	-0.2	-0.2	-0.4	-0.6	-0.9	-1.1	-1.3	-1.5	-1.7	-1.9	-2.1	-2.3	-2.5	-2.7	-3.0
300	0.0	0.0	-0.1	-0.1	-0.1	-0.1	-0.1	-0.2	-0.2	-0.2	-0.4	-0.6	-0.8	-1.0	-1.2	-1.4	-1.6	-1.8	-2.0	-2.2	-2.4	-2.6	-2.9

Originator: HM Date: 5/29/02

Checker: MH Date: 5/29/02

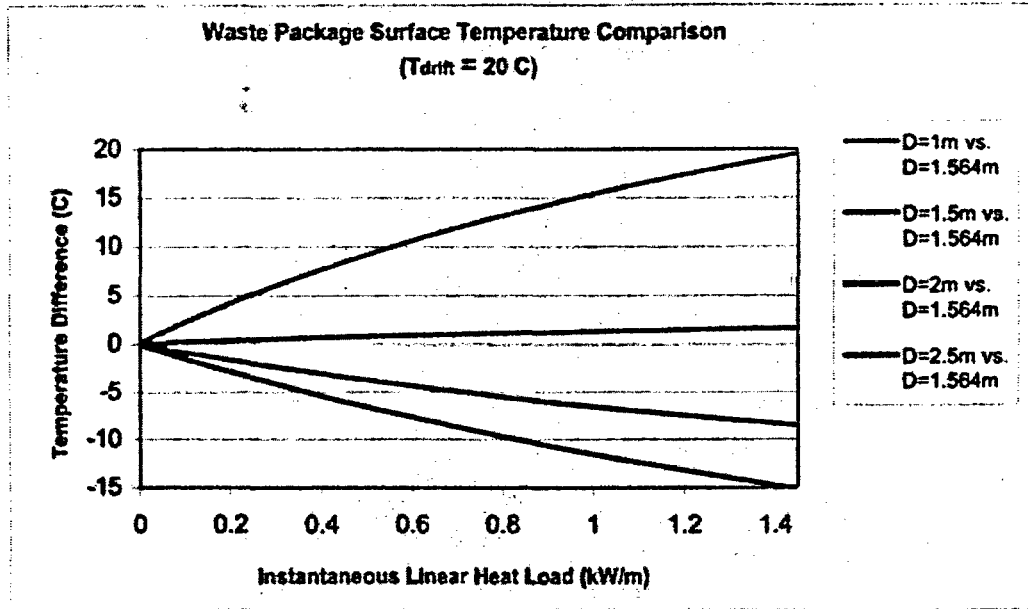

Figure 6-18. Waste Package Surface Temperature Comparison ( $T_{drift} = 20^{\circ}\text{C}$ )

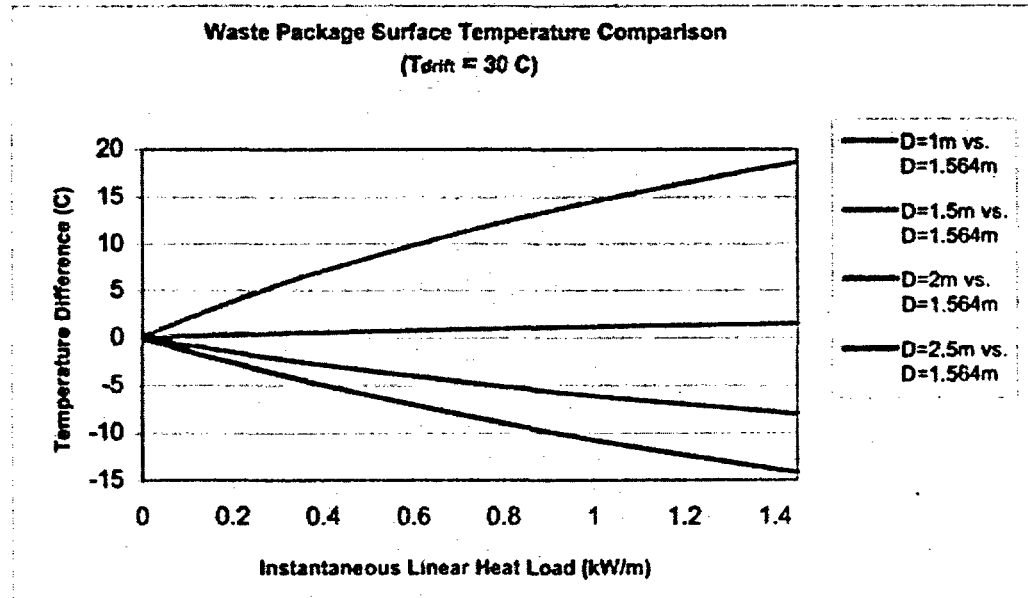

Figure 6-19. Waste Package Surface Temperature Comparison ( $T_{drift} = 30^{\circ}\text{C}$ )

Originator: HM Date: 5/29/02

Checker: MH Date: 5/29/02

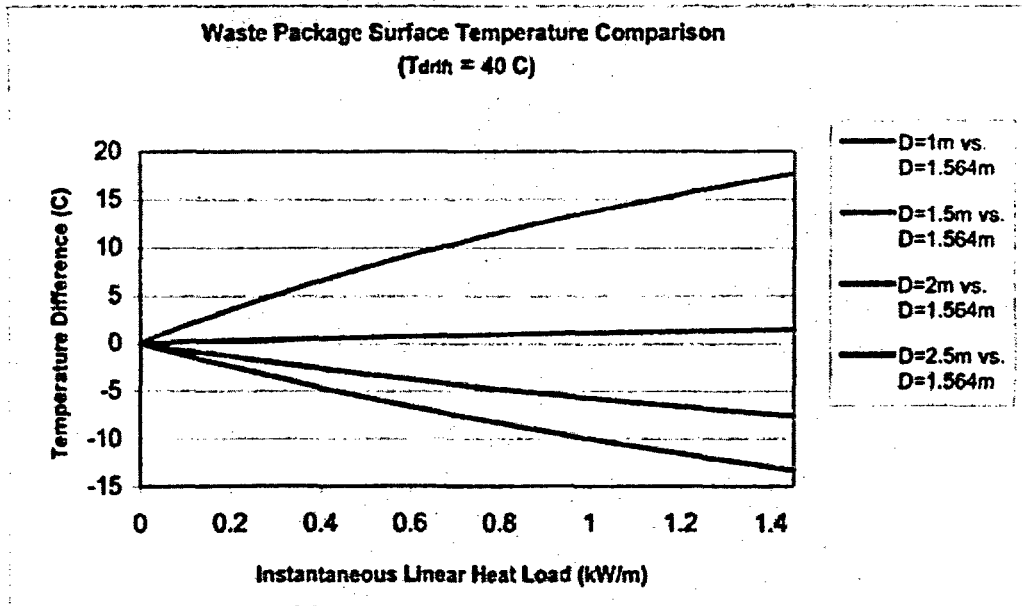

Figure 6-20. Waste Package Surface Temperature Comparison ( $T_{drift} = 40^{\circ}\text{C}$ )

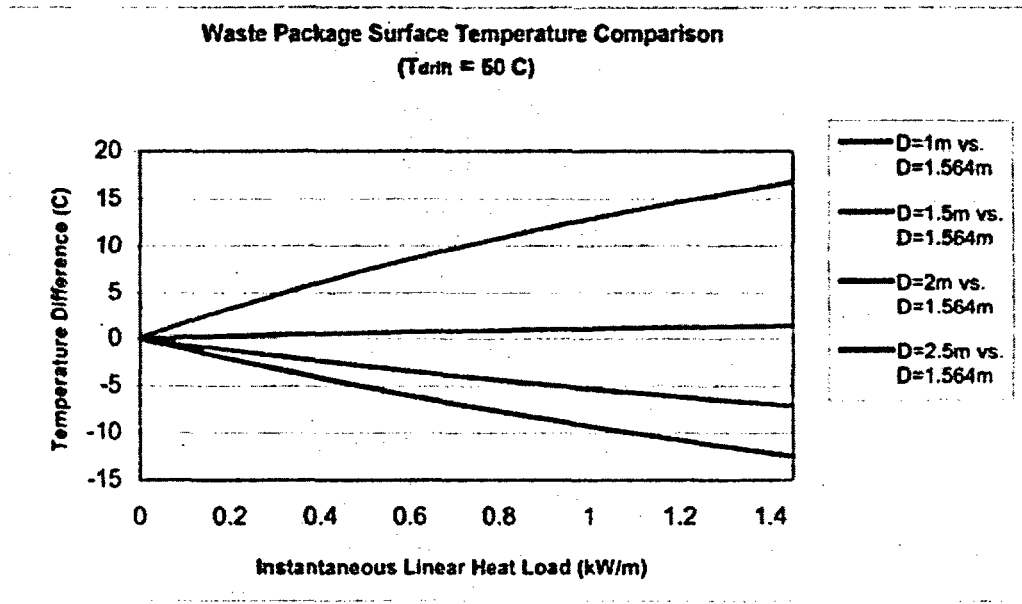

Figure 6-21. Waste Package Surface Temperature Comparison ( $T_{drift} = 50^{\circ}\text{C}$ )

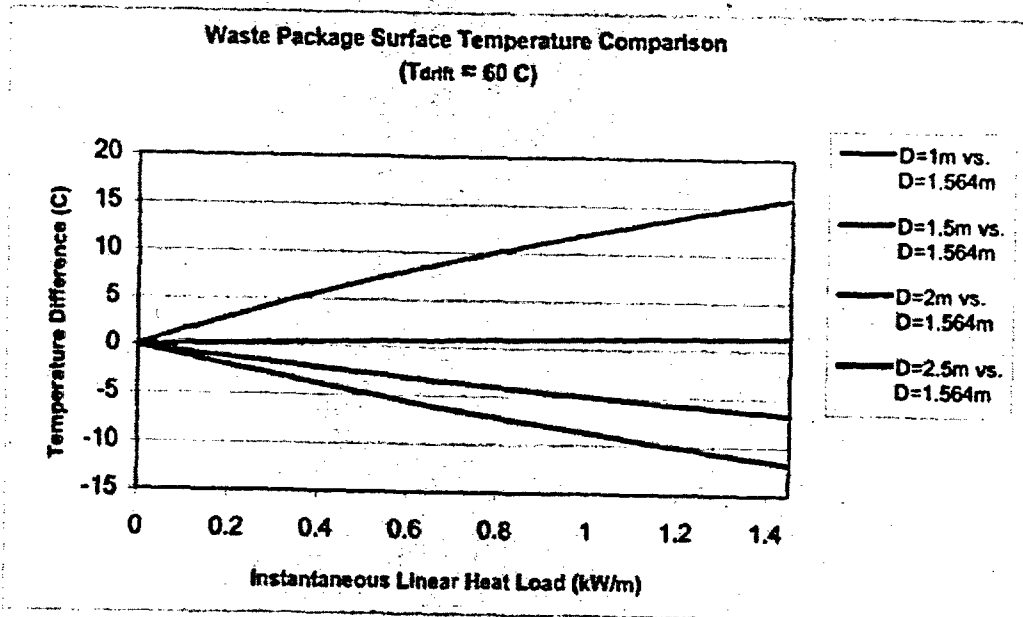

Figure 6-22. Waste Package Surface Temperature Comparison ( $T_{drift} = 60^{\circ}\text{C}$ )

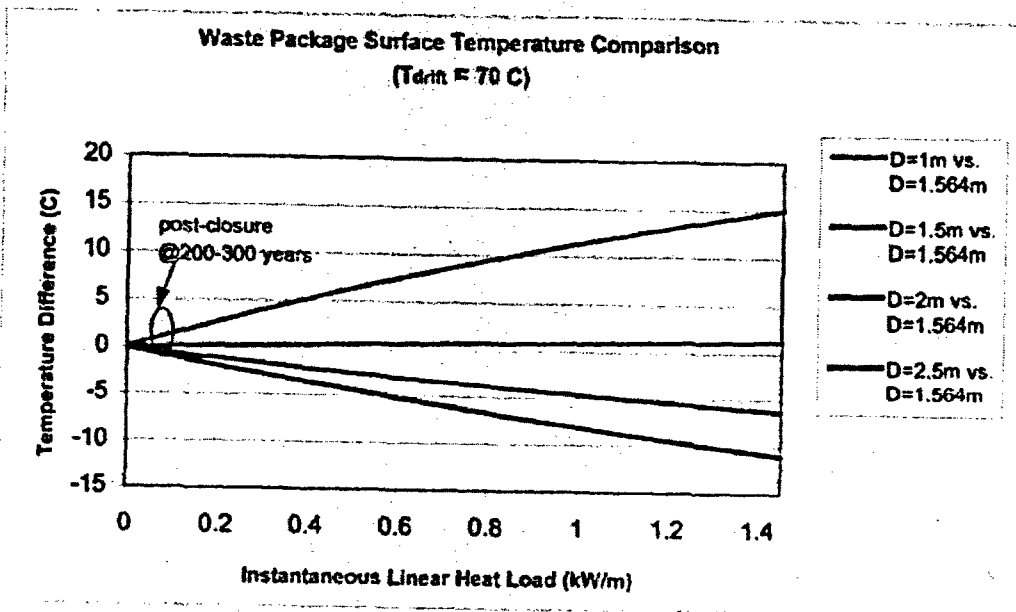

Figure 6-23. Waste Package Surface Temperature Comparison ( $T_{drift} = 70^{\circ}\text{C}$ )

Originator: HM Date: 5/29/02

Checker: MH Date: 5/29/02

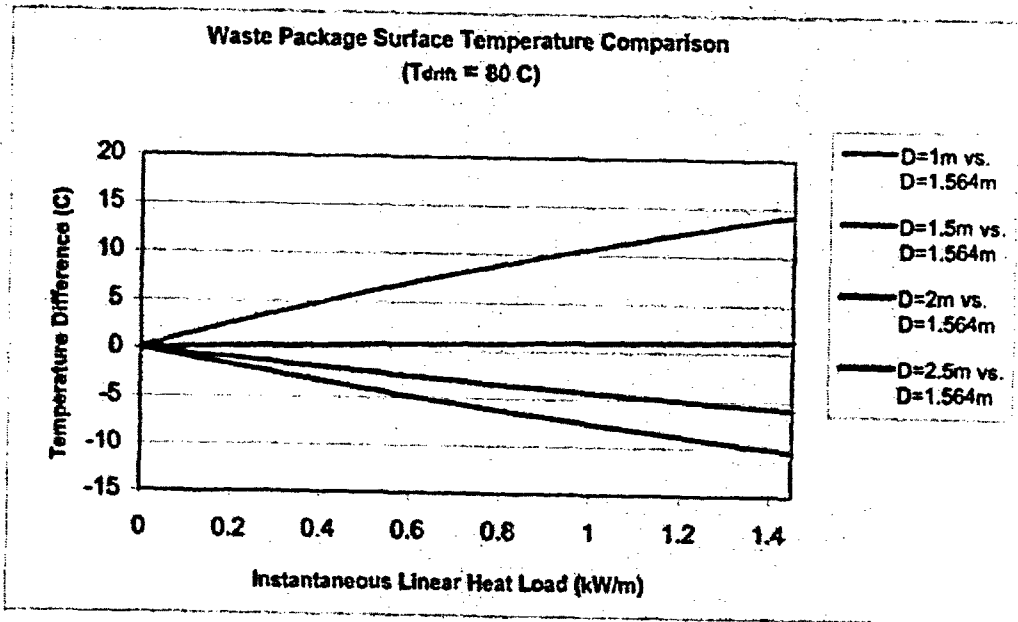

Figure 6-24. Waste Package Surface Temperature Comparison ( $T_{drift} = 80^{\circ}C$ )

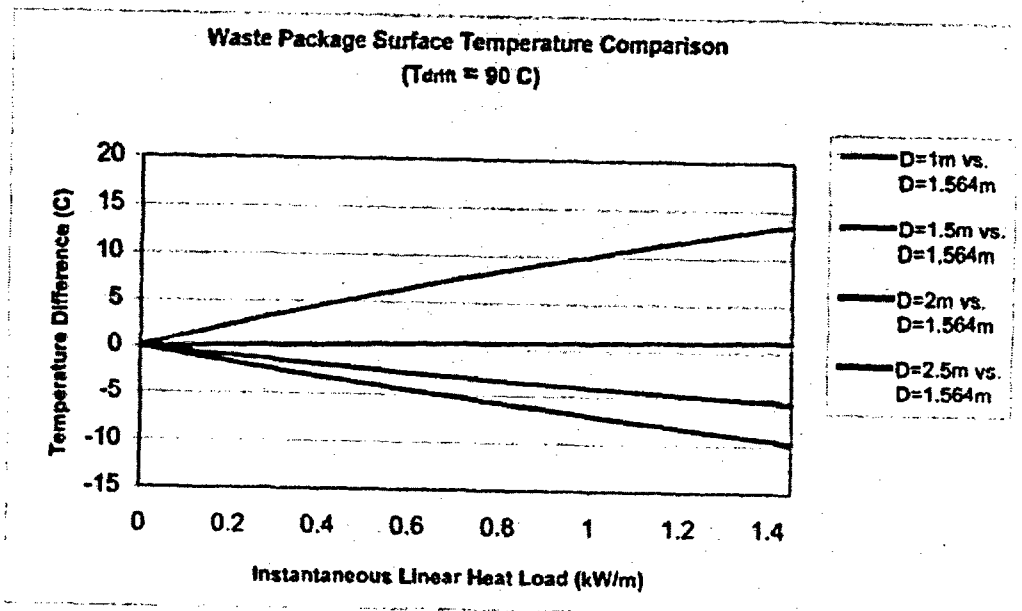

Figure 6-25. Waste Package Surface Temperature Comparison ( $T_{drift} = 90^{\circ}C$ )

Originator: HM Date: 5/29/02

Checker: MH Date: 5/29/02

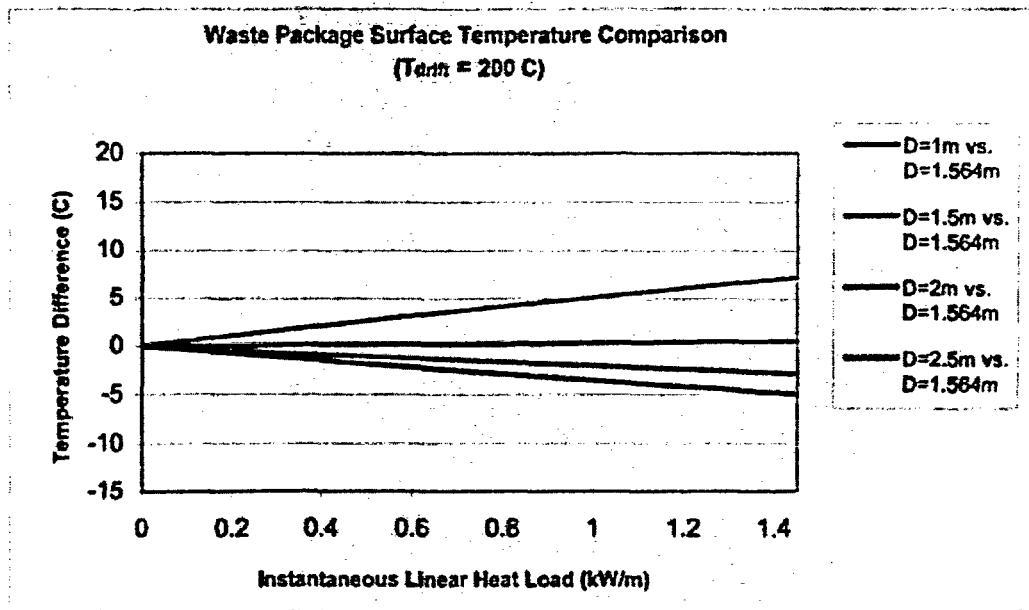

Figure 6-26. Waste Package Surface Temperature Comparison ( $T_{drift} = 200^{\circ}\text{C}$ )

Originator: HM Date: 5/29/02

Checker: MH Date: 5/29/02

## 7. REFERENCES

1. AP-3.12Q, Rev. 1, ICN 1. *Design Calculations and Analyses*. Washington, D.C.: U.S. Department of Energy. ACC: MOL.20020404.0079.
2. BSC (Bechtel SAIC Company) 2001. *Technical Work Plan for: Waste Package Design Description for LA*. TWP-EBS-MD-000004 REV 02. Las Vegas, Nevada: Bechtel SAIC Company. ACC: MOL.20011106.0177.
3. BSC (Bechtel SAIC Company) 2001. *Repository Multiple Waste Package Thermal Calculation*. CAL-WIS-TH-000010 REV 00. Las Vegas, Nevada: Bechtel SAIC Company. ACC: MOL.20010814.0330.
4. CRWMS M&O 2000. *Invert Effective Thermal Conductivity Calculation*. CAL-WIS-TH-000004 REV 00. Las Vegas, Nevada: CRWMS M&O. ACC: MOL.20000317.0593.
5. Linden, C. 2002. *Design Evolution Study—In-Drift Configuration*. TDR-MGR-MD-000008 REV 00. Las Vegas, Nevada: Bechtel SAIC Company. ACC: MOL.20020429.0022.
6. AP-SI.1Q Rev. 3, ICN 4. *Software Management*. Washington, D.C.: U.S. Department of Energy. ACC: MOL.20020520.0283.
7. CRWMS M&O 1998. *ANSYS V5.4. HP-UX 10.20. 30040 5.4*.
8. SN0003T0571897.013. Thermal Modeling Parameters by Stratigraphic Unit. Submittal date: 03/29/2000.
9. CRWMS M&O 1999. *Thermal Calculation of the Waste Package with Backfill*. BB0000000-01717-0210-00001 Rev 00. Las Vegas, Nevada: CRWMS M&O. ACC: MOL.19981214.0073.
10. GS000483351030.003. Preliminary Thermal Properties Measured 12/01/99 to 12/02/99 Using the Thermolink Soil Multimeter and Thermal Properties Sensor on Selected Potential Candidate Backfill Materials Used in the Engineered Barrier System. Submittal date: 11/09/2000.
11. Lide, D.R., ed. 1995. *CRC Handbook of Chemistry and Physics*. 76th Edition. Boca Raton, Florida: CRC Press. TIC: 216194.
12. Haynes International. 1988. Hastelloy Alloy C-22. Kokomo, Indiana: Haynes International. TIC: 239938.
13. CRWMS M&O 2000. *Software Code: ANSYS V5.6.2. HP-UX 10.20. 10364-5.6.2-00*.

Originator: HM Date: 5/29/02Checker: MM Date: 5/29/02

---

Title: Thermal Calculation of the In-Drift Configuration Options

Document Identifier: CAL-WIS-TH-000013 REV A

Page 64 of 65

---

14. AISC (American Institute of Steel Construction) 1989. *Manual of Steel Construction, Allowable Stress Design*. 9th Edition. Chicago, Illinois: American Institute of Steel Construction. TIC: 205770.
15. ASME (American Society of Mechanical Engineers) 1995. "Materials." Section II of *1995 ASME Boiler and Pressure Vessel Code*. New York, New York: American Society of Mechanical Engineers. TIC: 245287.
16. ASM International 1987. *Corrosion*. Volume 13 of *Metals Handbook*. 9th Edition. Metals Park, Ohio: ASM International. TIC: 209807.
17. Incropera, F.P. and DeWitt, D.P. 1996. *Fundamentals of Heat and Mass Transfer*. 4th Edition. New York, New York: John Wiley & Sons. TIC: 243950.
18. CRWMS M&O 1998. *Repository Ground Support Analysis for Viability Assessment*. BCAA00000-01717-0200-00004 REV 01. Las Vegas, Nevada: CRWMS M&O. ACC: MOL.19980512.0714.
19. BSC (Bechtel SAIC Company) 2001. *Repository Design, Waste Package, Project 21-PWR Waste Package with Absorber Plates, Sheet 1 of 3, Sheet 2 of 3, and Sheet 3 of 3*. DWG-UDC-ME-000001 REV A. Las Vegas, Nevada: Bechtel SAIC Company. ACC: MOL.20020102.0174.
20. CRWMS M&O 2000. *Invert Configuration and Drip Shield Interface*. TDR-EDS-ST-000001 REV 00. Las Vegas, Nevada: CRWMS M&O. ACC: MOL.20000505.0232.
21. DOE (U.S. Department of Energy) 2002. *Quality Assurance Requirements and Description*. DOE/RW-0333P, Rev. 11. Washington, D.C.: U.S. Department of Energy, Office of Civilian Radioactive Waste Management. ACC: MOL.20020506.0915.
22. SN0011T0571897.014. Revised Thermal Modeling Parameters for Conduction-Only Models by Stratigraphic Unit. Submittal date: 11/29/2000.
23. BSC (Bechtel SAIC Company) 2001. *Repository Design, Waste Package Project Interlocking Drip Shield, Sheet 1 of 3, Sheet 2 of 3, and Sheet 3 of 3*. DWG-EDS-ME-000001 REV A. Las Vegas, Nevada: Bechtel SAIC Company. ACC: MOL.20020102.0178.

Originator: HM Date: 5/29/02

Checker: MMH Date: 5/29/02



**8. ATTACHMENTS**

The attachments to this calculation are summarized in Table 8-1.

Table 8-1. Attachments Summary

Attachment Number	Description	Pages
I	Compact disk (CD) (1 of 1 ) containing ANSYS V5.4 and V5.6.2 files, and Excel files (see Attachment IV for file listing)	N/A
II	File Listing for Attachment I	4

Originator: HM Date: 5/29/02Checker: MH Date: 5/29/02

Title: Thermal Calculation of the In-Drift Configuration Options

Document Identifier: CAL-WIS-TH-000013 REV A

Attachment II-1

Table II-1. ANSYS and Excel File Listing

/ANSYS_Files/case1				/ANSYS_Files/case2			
File Name	Size (bytes)	Date	Time	File Name	Size (bytes)	Date	Time
d45_001.out	302,060	03/29/2002	2:38p	d55_001.out	305,023	03/29/2002	2:49p
d45_004.out	302,204	03/29/2002	2:39p	d55_004.out	305,023	03/29/2002	2:50p
d45_008.out	302,204	03/29/2002	2:39p	d55_008.out	305,023	03/29/2002	2:59p
d45_012.out	302,637	03/29/2002	2:40p	d55_012.out	305,168	03/29/2002	2:59p
d45_016.out	302,637	03/29/2002	2:40p	d55_016.out	305,600	03/29/2002	2:59p
d45_020.out	303,069	03/29/2002	2:40p	d55_020.out	305,744	03/29/2002	2:59p
d45_024.out	303,213	03/29/2002	2:40p	d55_024.out	306,032	03/29/2002	2:59p
d45_028.out	303,357	03/29/2002	2:40p	d55_028.out	306,176	03/29/2002	2:59p
d45_032.out	303,645	03/29/2002	2:40p	d55_032.out	306,320	03/29/2002	3:00p
d45_036.out	303,789	03/29/2002	2:41p	d55_036.out	306,320	03/29/2002	3:00p
d45_040.out	304,077	03/29/2002	2:41p	d55_040.out	306,608	03/29/2002	3:00p
d45_044.out	304,077	03/29/2002	2:41p	d55_044.out	306,464	03/29/2002	3:00p
d45_048.out	304,365	03/29/2002	2:41p	d55_048.out	306,896	03/29/2002	3:00p
d45_052.out	305,085	03/29/2002	2:41p	d55_052.out	306,896	03/29/2002	3:00p
d45_056.out	304,653	03/29/2002	2:41p	d55_056.out	307,763	03/29/2002	3:01p
d45_060.out	304,941	03/29/2002	2:42p	d55_060.out	307,040	03/29/2002	3:01p
d45_064.out	304,509	03/29/2002	2:42p	d55_064.out	307,184	03/29/2002	3:01p
d45_068.out	304,992	03/29/2002	2:42p	d55_068.out	307,040	03/29/2002	3:01p
d45_072.out	305,280	03/29/2002	2:42p	d55_072.out	307,616	03/29/2002	3:01p
d45_076.out	306,144	03/29/2002	2:42p	d55_076.out	307,472	03/29/2002	3:01p
d45_080.out	306,576	03/29/2002	2:42p	d55_080.out	307,184	03/29/2002	3:01p
d45_084.out	306,784	03/29/2002	2:42p	d55_084.out	308,691	03/29/2002	3:02p
d45_088.out	305,776	03/29/2002	2:43p	d55_088.out	308,835	03/29/2002	3:02p
d45_092.out	307,072	03/29/2002	2:43p	d55_092.out	309,123	03/29/2002	3:02p
d45_096.out	306,640	03/29/2002	2:43p	d55_096.out	308,547	03/29/2002	3:02p
d45_100.out	307,217	03/29/2002	2:43p	d55_100.out	308,900	03/29/2002	3:02p
d45_104.out	306,497	03/29/2002	2:43p	d55_104.out	309,124	03/29/2002	3:03p
d45_108.out	306,065	03/29/2002	2:43p	d55_108.out	308,756	03/29/2002	3:03p
d45_112.out	379,112	03/29/2002	2:43p	d55_112.out	309,396	03/29/2002	3:03p
d45_116.out	385,879	03/29/2002	2:44p	d55_116.out	308,900	03/29/2002	3:03p
d45_120.out	380,318	03/29/2002	2:44p	d55_120.out	308,180	03/29/2002	3:03p
d45_124.out	378,561	03/29/2002	2:44p	d55_124.out	308,532	03/29/2002	3:03p
d45_128.out	414,339	03/29/2002	2:44p	d55_128.out	308,327	03/29/2002	3:04p
d45_132.out	305,800	03/29/2002	2:44p	d55_132.out	308,052	03/29/2002	3:04p
d45_136.out	434,502	03/29/2002	2:44p	d55_136.out	308,337	03/29/2002	3:04p
d45_140.out	306,088	03/29/2002	2:44p	d55_140.out	308,913	03/29/2002	3:04p
d45_144.out	305,656	03/29/2002	2:45p	d55_144.out	372,523	03/29/2002	3:04p
pd45_001.out	19,993	03/29/2002	2:39p	pd55_001.out	19,993	03/29/2002	2:58p
pd45_004.out	19,993	03/29/2002	2:39p	pd55_004.out	19,993	03/29/2002	2:59p
pd45_008.out	19,993	03/29/2002	2:39p	pd55_008.out	19,852	03/29/2002	2:59p
pd45_012.out	19,993	03/29/2002	2:40p	pd55_012.out	19,993	03/29/2002	2:59p
pd45_016.out	19,993	03/29/2002	2:40p	pd55_016.out	19,993	03/29/2002	2:59p
pd45_020.out	19,993	03/29/2002	2:40p	pd55_020.out	19,993	03/29/2002	2:59p
pd45_024.out	19,993	03/29/2002	2:40p	pd55_024.out	19,993	03/29/2002	2:59p
pd45_028.out	19,993	03/29/2002	2:40p	pd55_028.out	19,993	03/29/2002	2:59p
pd45_032.out	19,993	03/29/2002	2:40p	pd55_032.out	19,993	03/29/2002	3:00p
pd45_036.out	19,993	03/29/2002	2:41p	pd55_036.out	19,993	03/29/2002	3:00p
pd45_040.out	19,993	03/29/2002	2:41p	pd55_040.out	19,993	03/29/2002	3:00p
pd45_044.out	19,993	03/29/2002	2:41p	pd55_044.out	19,993	03/29/2002	3:00p
pd45_048.out	19,993	03/29/2002	2:41p	pd55_048.out	19,993	03/29/2002	3:00p
pd45_052.out	19,993	03/29/2002	2:41p	pd55_052.out	19,993	03/29/2002	3:00p
pd45_056.out	19,993	03/29/2002	2:41p	pd55_056.out	19,993	03/29/2002	3:01p
pd45_060.out	19,993	03/29/2002	2:42p	pd55_060.out	19,993	03/29/2002	3:01p
pd45_064.out	19,993	03/29/2002	2:42p	pd55_064.out	19,993	03/29/2002	3:01p
pd45_068.out	19,993	03/29/2002	2:42p	pd55_068.out	19,993	03/29/2002	3:01p
pd45_072.out	19,993	03/29/2002	2:42p	pd55_072.out	19,993	03/29/2002	3:01p
pd45_076.out	19,993	03/29/2002	2:42p	pd55_076.out	19,993	03/29/2002	3:01p

Originator: HM Date: 5/29/02Checker: MH Date: 5/29/02

## Title: Thermal Calculation of the In-Drift Configuration Options

Document Identifier: CAL-WIS-TH-000013 REV A

Attachment II-2

pd45_080.out	19,993	03/29/2002	2:42p	pd55_080.out	19,993	03/29/2002	3:01p
pd45_084.out	19,993	03/29/2002	2:42p	pd55_084.out	19,993	03/29/2002	3:02p
pd45_088.out	19,993	03/29/2002	2:43p	pd55_088.out	19,993	03/29/2002	3:02p
pd45_092.out	19,993	03/29/2002	2:43p	pd55_092.out	19,993	03/29/2002	3:02p
pd45_096.out	19,993	03/29/2002	2:43p	pd55_096.out	19,993	03/29/2002	3:02p
pd45_100.out	19,993	03/29/2002	2:43p	pd55_100.out	19,993	03/29/2002	3:02p
pd45_104.out	19,993	03/29/2002	2:43p	pd55_104.out	19,993	03/29/2002	3:03p
pd45_108.out	19,993	03/29/2002	2:43p	pd55_108.out	19,993	03/29/2002	3:03p
pd45_112.out	19,993	03/29/2002	2:43p	pd55_112.out	19,993	03/29/2002	3:03p
pd45_116.out	19,993	03/29/2002	2:44p	pd55_116.out	19,993	03/29/2002	3:03p
pd45_120.out	19,993	03/29/2002	2:44p	pd55_120.out	19,993	03/29/2002	3:03p
pd45_124.out	19,993	03/29/2002	2:44p	pd55_124.out	19,993	03/29/2002	3:04p
pd45_128.out	19,993	03/29/2002	2:44p	pd55_128.out	19,993	03/29/2002	3:04p
pd45_132.out	19,993	03/29/2002	2:44p	pd55_132.out	19,993	03/29/2002	3:04p
pd45_136.out	19,993	03/29/2002	2:44p	pd55_136.out	19,993	03/29/2002	3:04p
pd45_140.out	19,993	03/29/2002	2:44p	pd55_140.out	19,993	03/29/2002	3:04p
pd45_144.out	19,993	03/29/2002	2:45p	pd55_144.out	19,302	03/29/2002	3:04p
/ANSYS_Files/case3				/ANSYS_Files/case4			
File Name	Size (bytes)	Date	Time	File Name	Size (bytes)	Date	Time
d60_001.out	357,736	03/29/2002	3:05p	d60_001.out	304,676	03/29/2002	4:05p
d60_004.out	357,528	03/29/2002	3:05p	d60_004.out	304,820	03/29/2002	4:05p
d60_008.out	357,736	03/29/2002	3:57p	d60_008.out	304,964	03/29/2002	4:05p
d60_012.out	357,737	03/29/2002	3:57p	d60_012.out	305,541	03/29/2002	4:05p
d60_016.out	358,153	03/29/2002	3:57p	d60_016.out	305,973	03/29/2002	4:05p
d60_020.out	358,777	03/29/2002	3:57p	d60_020.out	306,117	03/29/2002	4:05p
d60_024.out	358,985	03/29/2002	3:58p	d60_024.out	306,117	03/29/2002	4:05p
d60_028.out	359,753	03/29/2002	3:58p	d60_028.out	306,405	03/29/2002	4:05p
d60_032.out	359,753	03/29/2002	3:58p	d60_032.out	306,405	03/29/2002	4:05p
d60_036.out	359,753	03/29/2002	3:58p	d60_036.out	306,405	03/29/2002	4:05p
d60_040.out	359,545	03/29/2002	3:58p	d60_040.out	306,693	03/29/2002	4:05p
d60_044.out	359,961	03/29/2002	3:58p	d60_044.out	306,837	03/29/2002	4:06p
d60_048.out	359,961	03/29/2002	3:58p	d60_048.out	306,837	03/29/2002	4:06p
d60_052.out	360,729	03/29/2002	3:59p	d60_052.out	307,413	03/29/2002	4:06p
d60_056.out	360,793	03/29/2002	3:59p	d60_056.out	307,557	03/29/2002	4:06p
d60_060.out	360,937	03/29/2002	3:59p	d60_060.out	307,701	03/29/2002	4:06p
d60_064.out	361,225	03/29/2002	3:59p	d60_064.out	307,701	03/29/2002	4:06p
d60_068.out	361,033	03/29/2002	3:59p	d60_068.out	309,150	03/29/2002	4:06p
d60_072.out	361,964	03/29/2002	3:59p	d60_072.out	307,989	03/29/2002	4:06p
d60_076.out	361,244	03/29/2002	3:59p	d60_076.out	309,147	03/29/2002	4:06p
d60_080.out	361,484	03/29/2002	3:59p	d60_080.out	308,421	03/29/2002	4:06p
d60_084.out	361,596	03/29/2002	3:59p	d60_084.out	308,421	03/29/2002	4:07p
d60_088.out	362,111	03/29/2002	4:02p	d60_088.out	308,277	03/29/2002	4:07p
d60_092.out	361,465	03/29/2002	4:02p	d60_092.out	308,824	03/29/2002	4:07p
d60_096.out	362,025	03/29/2002	4:02p	d60_096.out	309,115	03/29/2002	4:07p
d60_100.out	362,877	03/29/2002	4:02p	d60_100.out	309,548	03/29/2002	4:07p
d60_104.out	362,256	03/29/2002	4:02p	d60_104.out	309,257	03/29/2002	4:07p
d60_108.out	361,578	03/29/2002	4:03p	d60_108.out	309,401	03/29/2002	4:07p
d60_112.out	362,797	03/29/2002	4:03p	d60_112.out	309,692	03/29/2002	4:07p
d60_116.out	362,522	03/29/2002	4:03p	d60_116.out	309,404	03/29/2002	4:08p
d60_120.out	290,823	03/29/2002	4:03p	d60_120.out	310,271	03/29/2002	4:08p
d60_124.out	362,464	03/29/2002	4:03p	d60_124.out	310,124	03/29/2002	4:08p
d60_128.out	362,093	03/29/2002	4:03p	d60_128.out	309,401	03/29/2002	4:09p
d60_132.out	361,722	03/29/2002	4:03p	d60_132.out	310,044	03/29/2002	4:09p
d60_136.out	362,877	03/29/2002	4:04p	d60_136.out	309,977	03/29/2002	4:09p
d60_140.out	362,733	03/29/2002	4:04p	d60_140.out	309,113	03/29/2002	4:09p
d60_144.out	290,544	03/29/2002	4:04p	d60_144.out	310,335	03/29/2002	4:09p
/ANSYS_Files/case5				/ANSYS_Files/case6			
File Name	Size (bytes)	Date	Time	File Name	Size (bytes)	Date	Time
d50_001.out	301,569	03/29/2002	4:10p	d40_001.out	296,977	03/29/2002	4:15p
d50_004.out	301,569	03/29/2002	4:10p	d40_004.out	297,121	03/29/2002	4:15p
d50_008.out	301,713	03/29/2002	4:10p	d40_008.out	297,121	03/29/2002	4:15p

Originator: HAM Date: 5/29/02Checker: MH Date: 5/29/02

Title: Thermal Calculation of the In-Drift Configuration Options

Document Identifier: CAL-WIS-TH-000013 REV A

Attachment II-3

d50_012.out	302,290	03/29/2002	4:10p	d40_012.out	297,410	03/29/2002	4:15p
d50_016.out	302,722	03/29/2002	4:10p	d40_016.out	297,554	03/29/2002	4:15p
d50_020.out	303,010	03/29/2002	4:10p	d40_020.out	297,842	03/29/2002	4:15p
d50_024.out	303,010	03/29/2002	4:10p	d40_024.out	298,274	03/29/2002	4:15p
d50_028.out	303,298	03/29/2002	4:11p	d40_028.out	298,274	03/29/2002	4:15p
d50_032.out	303,298	03/29/2002	4:11p	d40_032.out	298,706	03/29/2002	4:15p
d50_036.out	303,442	03/29/2002	4:11p	d40_036.out	298,562	03/29/2002	4:15p
d50_040.out	303,586	03/29/2002	4:11p	d40_040.out	298,994	03/29/2002	4:16p
d50_044.out	303,730	03/29/2002	4:11p	d40_044.out	299,429	03/29/2002	4:16p
d50_048.out	303,874	03/29/2002	4:11p	d40_048.out	298,994	03/29/2002	4:16p
d50_052.out	303,874	03/29/2002	4:11p	d40_052.out	299,717	03/29/2002	4:16p
d50_056.out	304,888	03/29/2002	4:11p	d40_056.out	299,426	03/29/2002	4:16p
d50_060.out	305,131	03/29/2002	4:11p	d40_060.out	299,429	03/29/2002	4:16p
d50_064.out	304,885	03/29/2002	4:12p	d40_064.out	299,282	03/29/2002	4:16p
d50_068.out	304,885	03/29/2002	4:12p	d40_068.out	299,429	03/29/2002	4:16p
d50_072.out	304,882	03/29/2002	4:12p	d40_072.out	300,152	03/29/2002	4:16p
d50_076.out	305,026	03/29/2002	4:12p	d40_076.out	301,013	03/29/2002	4:16p
d50_080.out	304,882	03/29/2002	4:12p	d40_080.out	301,224	03/29/2002	4:17p
d50_084.out	305,752	03/29/2002	4:12p	d40_084.out	301,867	03/29/2002	4:17p
d50_088.out	304,882	03/29/2002	4:12p	d40_088.out	300,146	03/29/2002	4:17p
d50_092.out	305,026	03/29/2002	4:12p	d40_092.out	300,437	03/29/2002	4:17p
d50_096.out	305,026	03/29/2002	4:13p	d40_096.out	301,016	03/29/2002	4:17p
d50_100.out	305,606	03/29/2002	4:13p	d40_100.out	300,726	03/29/2002	4:17p
d50_104.out	304,883	03/29/2002	4:13p	d40_104.out	300,147	03/29/2002	4:17p
d50_108.out	305,171	03/29/2002	4:13p	d40_108.out	300,726	03/29/2002	4:17p
d50_112.out	306,441	03/29/2002	4:13p	d40_112.out	301,158	03/29/2002	4:18p
d50_116.out	305,747	03/29/2002	4:13p	d40_116.out	300,585	03/29/2002	4:18p
d50_120.out	305,462	03/29/2002	4:13p	d40_120.out	300,579	03/29/2002	4:18p
d50_124.out	305,606	03/29/2002	4:14p	d40_124.out	301,718	03/29/2002	4:18p
d50_128.out	306,249	03/29/2002	4:14p	d40_128.out	301,014	03/29/2002	4:18p
d50_132.out	305,894	03/29/2002	4:14p	d40_132.out	301,014	03/29/2002	4:18p
d50_136.out	306,166	03/29/2002	4:14p	d40_136.out	301,289	03/29/2002	4:19p
d50_140.out	305,897	03/29/2002	4:14p	d40_140.out	300,425	03/29/2002	4:19p
d50_144.out	305,654	03/29/2002	4:14p	d40_144.out	301,062	03/29/2002	4:19p

/ANSYS_Files/SR_dp				/ANSYS_Files/SR_nd			
File Name	Size (bytes)	Date	Time	File Name	Size (bytes)	Date	Time
d55_001.out	283,814	04/11/2002	3:40p	d55_001.out	268,203	04/03/2002	10:22a
d55_004.out	283,830	04/11/2002	3:40p	d55_004.out	268,347	04/03/2002	10:22a
d55_008.out	283,831	04/11/2002	3:40p	d55_008.out	268,347	04/03/2002	10:22a
d55_012.out	283,831	04/11/2002	3:40p	d55_012.out	268,492	04/03/2002	10:23a
d55_016.out	284,039	04/11/2002	4:11p	d55_016.out	269,068	04/03/2002	10:23a
d55_020.out	284,455	04/11/2002	4:11p	d55_020.out	269,212	04/03/2002	10:23a
d55_024.out	284,871	04/11/2002	3:41p	d55_024.out	269,644	04/03/2002	10:23a
d55_028.out	285,847	04/11/2002	3:41p	d55_028.out	269,788	04/03/2002	10:23a
d55_032.out	285,639	04/11/2002	3:41p	d55_032.out	269,932	04/03/2002	10:23a
d55_036.out	285,847	04/11/2002	3:41p	d55_036.out	270,367	04/03/2002	10:23a
d55_040.out	286,056	04/11/2002	3:41p	d55_040.out	270,364	04/03/2002	10:24a
d55_044.out	286,039	04/11/2002	3:42p	d55_044.out	270,220	04/03/2002	10:24a
d55_048.out	286,055	04/11/2002	3:42p	d55_048.out	270,511	04/03/2002	10:24a
d55_052.out	286,327	04/11/2002	3:42p	d55_052.out	270,796	04/03/2002	10:24a
d55_056.out	287,031	04/11/2002	3:42p	d55_056.out	270,364	04/03/2002	10:24a
d55_060.out	286,472	04/11/2002	3:42p	d55_060.out	271,234	04/03/2002	10:24a
d55_064.out	287,562	04/11/2002	3:42p	d55_064.out	271,084	04/03/2002	10:24a
d55_068.out	288,253	04/11/2002	3:42p	d55_068.out	271,522	04/03/2002	10:24a
d55_072.out	286,919	04/11/2002	3:42p	d55_072.out	271,519	04/03/2002	10:25a
d55_076.out	287,674	04/11/2002	3:42p	d55_076.out	271,372	04/03/2002	10:25a
d55_080.out	287,672	04/11/2002	3:43p	d55_080.out	272,306	04/03/2002	10:25a
d55_084.out	287,528	04/11/2002	3:43p	d55_084.out	272,744	04/03/2002	10:25a
d55_088.out	287,511	04/11/2002	3:43p	d55_088.out	272,082	04/03/2002	10:25a
d55_092.out	288,618	04/11/2002	3:43p	d55_092.out	271,951	04/03/2002	10:25a
d55_096.out	288,638	04/11/2002	3:43p	d55_096.out	272,575	04/03/2002	10:25a

Originator: HM Date: 5/29/02

Checker: MH Date: 5/29/02

Title: Thermal Calculation of the In-Drift Configuration Options

Document Identifier: CAL-WIS-TH-000013 REV A

Attachment II-4

d55_100.out	287,944	04/11/2002	3:44p	d55_100.out	273,075	04/03/2002	10:25a
d55_104.out	287,755	04/11/2002	3:44p	d55_104.out	272,640	04/03/2002	10:26a
d55_108.out	288,833	04/11/2002	3:44p	d55_108.out	273,654	04/03/2002	10:26a
d55_112.out	290,491	04/11/2002	3:44p	d55_112.out	273,360	04/03/2002	10:26a
d55_116.out	287,656	04/11/2002	3:44p	d55_116.out	272,784	04/03/2002	10:26a
d55_120.out	287,601	04/11/2002	3:44p	d55_120.out	273,449	04/03/2002	10:26a
d55_124.out	288,107	04/11/2002	3:44p	d55_124.out	273,507	04/03/2002	10:26a
d55_128.out	288,955	04/11/2002	3:45p	d55_128.out	272,208	04/03/2002	10:26a
d55_132.out	287,960	04/11/2002	3:45p	d55_132.out	273,072	04/03/2002	10:26a
d55_136.out	288,952	04/11/2002	3:45p	d55_136.out	273,219	04/03/2002	10:27a
d55_140.out	289,022	04/11/2002	3:45p	d55_140.out	273,075	04/03/2002	10:27a
d55_144.out	289,399	04/11/2002	3:45p	d55_144.out	274,227	04/03/2002	10:27a
d55_5c.out	407,027	04/16/2002	9:00a	d55_5c.out	391,885	04/03/2002	11:49a
/Excel_Files/				/Ansys_Files/			
File Name	Size (bytes)	Date	Time	File Name	Size (bytes)	Date	Time
d55_dr_fit.xls	188,928	05/22/2002	4:43p	mater_3d1.dat	13,375	03/29/2002	4:19p
d55_dr_nodri p_fit.xls	201,728	04/17/2002	9:13a				
d55_bh_gs_fit .xls	180,224	04/01/2002	2:28p				
wpdia.xls	310,784	04/17/2002	9:25a				

Originator: Am Date: 5/29/02Checker: AMH Date: 5/29/02

