

COPRA™ FANS COMPACT AND EFFICIENT. THE PERFECT MATCH.

THE SPACE-SAVING CENTRIFUGAL FAN SYSTEM.

CATALOG VERSION 1.0

PUTTING AN END TO COMPROMISE

COPRA™ fans combine high system efficiency, decisive compactness and high power density for the best overall performance.

The new space-saving COPRA system is comprised of a motor, impeller and integrated controller. It combines three properties in a way that previously seemed almost impossible: exceptional compactness, outstanding system efficiency and high power density. Its short motor does not restrict airflow while minimizing the space needed for the system. This, with the newly developed aerodynamic impeller design, delivers maximum efficiency – especially at reduced operating speeds.

Compared to conventional plug fans, COPRA™ fans offer maximum airflow with the greatest possible efficiency and significantly reduce footprint for all sizes. With its low installation losses, the new aluminum impeller demonstrates its advantages to the fullest, even in confined installation conditions. This makes COPRA fans the ideal solution in HVAC systems, data centers, and many other areas.

Why only improve, when you can reinvent?

For good reasons, plug or hybrid radial fans have largely replaced fans with scroll housings in air-conditioning applications. Even though the latter have some positive physical characteristics, plug fans take up less space, and drive losses due to belts, bearings or couplings are not an issue. Planners are particularly focused on lower pressures. In addition, the European Ecodesign Directive prescribes variable-speed drives. This favors direct-drive solutions.

In terms of physics, plug impellers can only achieve a pressure increase or energy conversion via two factors: a swirl added to the flow and a maximum delay in the relative flow in the impeller's blade channel.

A swirl in the flow at the exit from the impeller is unavoidable and necessary for energy conversion. However, this swirl also represents a loss in air-conditioning applications. As a result, fan concepts of this kind can achieve maximum aerodynamic system efficiencies of around 70%. We have achieved these maximum plug static efficiencies with COPRA™ fans.

The only way to gain more static efficiency from the energy of the flow swirl at the impeller exit is to use guide vanes, specifically a direct-driven hybrid fan with multiple discharge scrolls. However, this is typically less compact in design. Taking the above aspects into account, we have achieved greater aerodynamic efficiency levels with a reduced footprint in the development of the COPRA system.



Consolidated characteristics: overview of sizes.

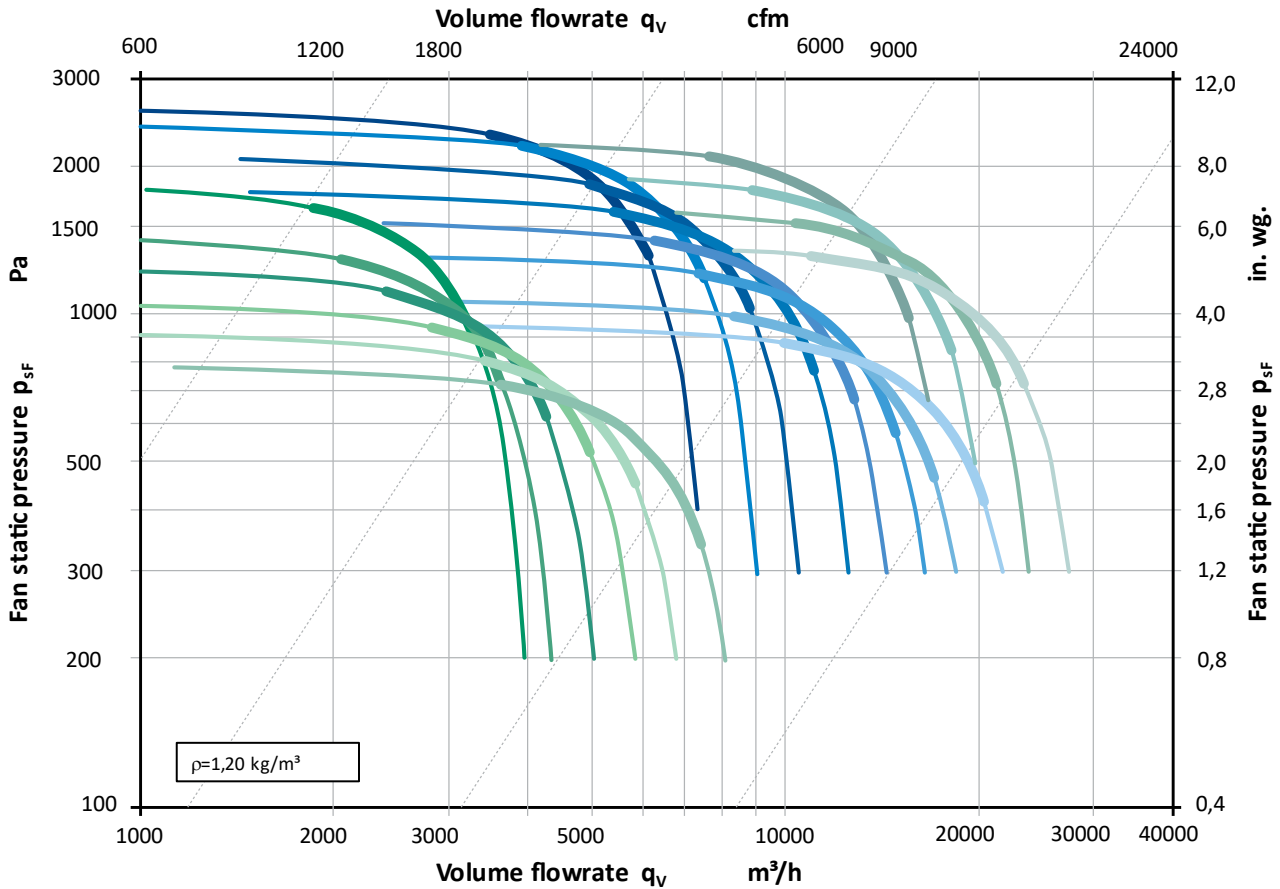

The chart shows an overview of sizes 250 mm to 710 mm with up to 8 kW motor power at the maximum speed of the respective size. The ranges with the best overall static fan efficiencies (operating range with best efficiency) are highlighted.

COPRA™

COPRA CORE 1.3 – 8 kW COPRA PLUG 1.3 – 8 kW

- Internal-rotor motor PM/EC technology with efficiency up to IE6
- Integrated electronics
- Air volume up to 28,000 m^3/h / 16,480 CFM
- Static pressures up to 2,000 Pa / ~6.8" wg
- Installation made simple with frame system
- UL/CE certified



COPRA CORE

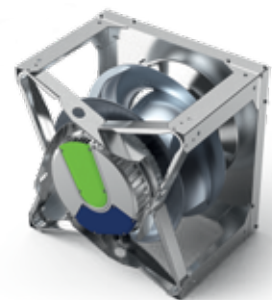

COPRA PLUG

Impeller

- Aluminum, welded; 3-dimensional backward curved blade design
- Impeller diameters: 250, 280, 315, 355, 400, 450, 500, 560, 630, 710 mm
- Maximum static pressure 2,000 Pa / ~6.8" wg
- Maximum circumferential speed at impeller outer diameter: ~70 m/s
- Conical backplate

Motor

- 1.3 kW, 4.5 kW, 8 kW
- 208-230 V 50/60 Hz 3~
- 380-460 V 50/60 Hz 3~
- No use of rare earth magnets
- Operating temperature range: -20 to +40 °C

A PERFECT COMBINATION

Maximum airflow, maximum efficiency together on one unit; with COPRA™ fans, the motor and impeller are optimally matched.

In the new COPRA™ fans, a perfect combination of impeller and motor across all sizes ensures maximum airflow with the highest possible efficiency and no mutual aerodynamic interference. Every application benefits from the perfect fit of COPRA™ fans' motor and impeller. Aerodynamically, the new impeller is one of the best currently available. It also enables a perfect symbiosis with the new motor form factor. Since the new internal-rotor motor is very short and its motor hub does not recede into the impeller it does not obstruct the impeller airflow. And at the same time, the overall system is highly compact and has a small footprint.

Standout features: maximum aerodynamic efficiency levels with ultra small footprint.

Conventional plug fans with external-rotor motors are hard to improve in terms of system efficiency and compactness. The greatest optimization potential for fan systems lies in adapting the characteristics of the drive required for the application in terms of the geometry and specifications – without aerodynamic disturbance or the need for additional cooling. It is precisely this goal – the perfect motor/impeller combination – that we have pursued and achieved in the development of COPRA™ fans. We have perfectly matched the motor and impeller geometrically and with regard to the necessary power, speed and speed range, aerodynamics, pressure increase, and corresponding torque. We have eliminated any mutual aerodynamic interference.

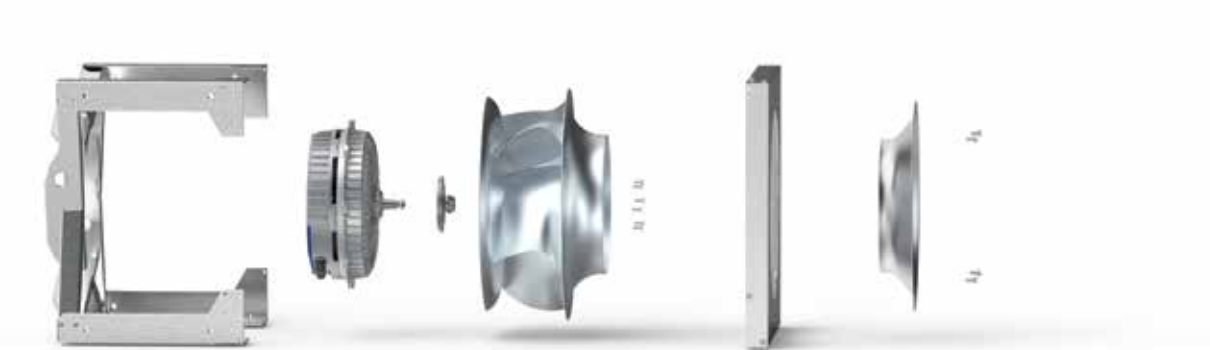

The Impeller

The new aluminum impeller with its advanced geometry can compete aerodynamically with the best impellers. Its three-dimensional backward curved blade design provides the necessary width to achieve a physical balance of forces between the flow lines and flow surfaces. It avoids an unfavorable cross-flow within the impeller. The profiled design (hollow profile) achieves the best aerodynamic properties at the respective flow surfaces for the pressure increase in the blade region. The profile cross-sections are designed as airfoils, in order to optimize the flow on the suction and pressure sides of the blades at every position within the impeller.

The Motor

The COPRA™ fans' motor sets the benchmark with its maximum efficiency and high effectiveness. At the same time, it has to be as compact as possible in combination with the impeller – and without negatively affecting the aerodynamics. For centrifugal fans with an impeller within a plug arrangement, this means the motor must be as short as possible. We have achieved all this with the PM/EC motor in COPRA™ fans. It achieves an efficiency class of up to IE6. Moreover, the COPRA™ fans' motor does not require direct cooling by air circulation or a separate cooling system. The integrated cooling of the motor electronics is sufficient. In any case, the motor's high efficiency means it requires less cooling. This makes the motor and system extremely reliable in operation.

Compact and efficient without impeller obstruction: COPRA™ fans make the impossible possible.

The size and shape of an external-rotor motor have an immense impact on the aerodynamic efficiency of a fan. The problem here is obstruction of the impeller airflow. With COPRA™ fans, it has been possible to avoid impeller obstruction and still achieve an extremely compact, highly efficient centrifugal fan system with an internal rotor. Solutions that are compact but compromise on efficiency are now a thing of the past. COPRA™ fans therefore unlock completely new potential for saving energy and costs.

Partly because of how they were historically developed, the design of external-rotor motors is better suited to axial flow fans than centrifugal fans. Nevertheless, despite the aerodynamic disadvantage of obstructing the airflow in the impeller, they have also become widely used for centrifugal fans. However, especially with compact EC motors, the motor protruding into the impeller significantly reduces system efficiency.

Pulling the motor out of the impeller – withdrawing it into a cone-shaped impeller or backplate – does reduce impeller obstruction, because the fan hub no longer protrudes into the impeller. However, this sacrifices the system's footprint. Yet

compactness is a crucial requirement in many applications. This is because, particularly where space is limited, fan solutions with pulled-out motors cannot be implemented in some applications due to their length.

Using an EC external-rotor motor in a plug fan is always a compromise between efficiency and overall length. This is why COPRA™ fans, with a very short internal-rotor motor, consistently prove to be the ideal, compromise-free, and therefore highly economical, system solution.



Fan solution with external-rotor motor and obstruction of the airflow in the impeller.

Fan solution with COPRA™ technology, without obstructing the airflow in the impeller.

CREATING SPACE WHERE THERE IS NONE

In short, COPRA™ fans are the ideal system for tight installation spaces.

In the new COPRA™ fans, it has been possible to make the internal rotor motor so short that it does not obstruct the impeller's airflow as is the case in conventional fan solutions. This creates ideal conditions for particularly economical operation even in tight installation spaces; the shortest axial length with maximum efficiency.

At the same time, the new motor/impeller concept ensures very low installation losses. There are hardly any unexpected, disadvantageous interactions between fan and application. A major reason for this is the modified overall geometry of the impeller.

No more compromise: short axial length plus high efficiency.

Typical competitive fans use external rotor motors while COPRA™ fans use a compact internal rotor motor. For fans with external rotor motors (left), pulling the motor out of the impeller provides high efficiency, but makes the system longer. In addition, cooling is required for the external rotor motor due to the lack of air stream around the rotor in the impeller.

For systems with an external rotor located inside the impeller (center), the opposite is true. The system is compact and the motor is cooled in the airstream, but unavoidable turbulence in the impeller considerably reduces the aerodynamic efficiency.

COPRA™ fans (right) utilize the best features from both configurations without the compromises. The exclusively-designed short motor does not protrude into the impeller, making the system extremely compact and does not generate any turbulence. It also has integrated cooling for the electronics. The result is the best efficiency with maximum compactness of the system.

With its outstanding compactness, COPRA™ fans are ideal for use in specific applications in data centers, or in ventilation and air-conditioning system fan arrays, where installations can often be made a crucial few centimeters shorter. This results in valuable material cost savings.

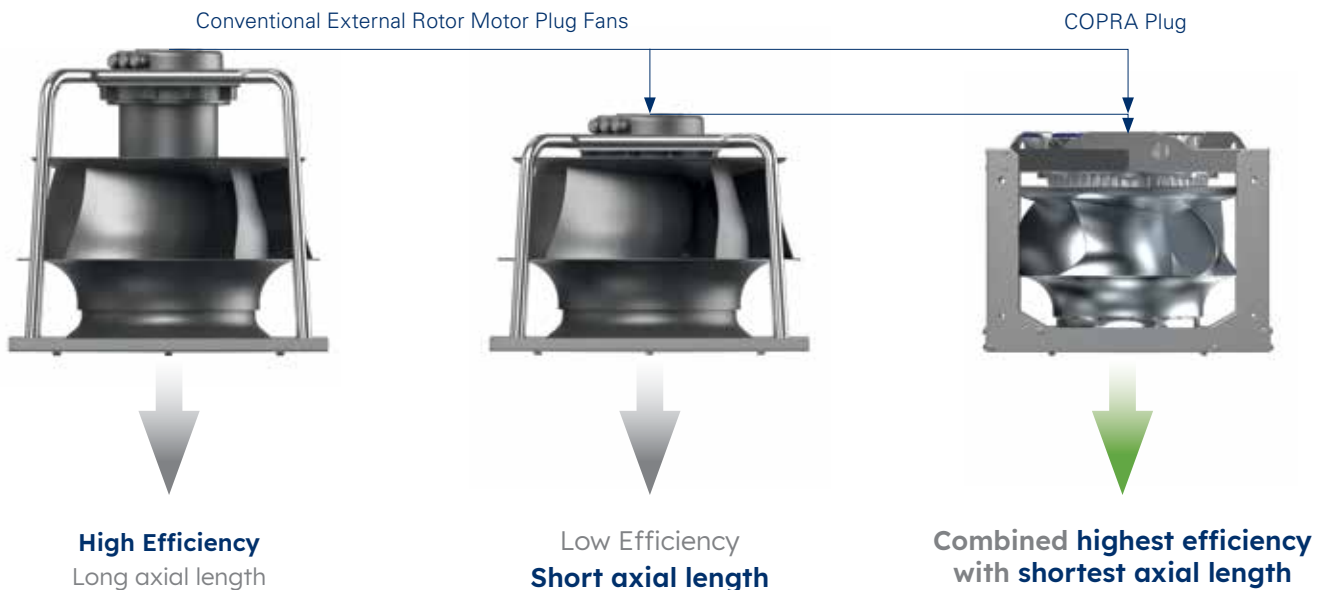

COPRA™ fans: the perfect system for tight installation spaces.

Tight installation spaces cause many challenges for centrifugal fan systems. The usual problem here is that the fan is not running under ideal conditions, and efficiency drops due to the limited gap between the fan and the chamber walls. In this case, the actual values can differ significantly from the catalog data measured in the laboratory.

COPRA™ fans, by contrast, show their strengths particularly under such difficult installation conditions. The technical reasons for this are found in the modified overall geometry of the impeller. They include its three-dimensional properties with large flow surfaces resulting in relatively low flow velocities, as well as the conical backplate and different diameters on the backplate and cover plate.

Compared to conventional EC fans, for example, COPRA™ fans attain the maximum achievable aerodynamic static pressure increase and static efficiency. The specific performance, i.e. the relationship between the power consumption for given diameters and speeds, and the volume of air moved, has been optimized.

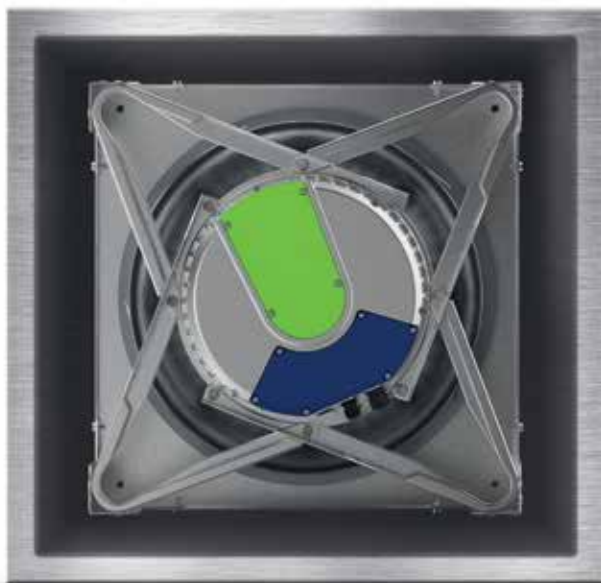
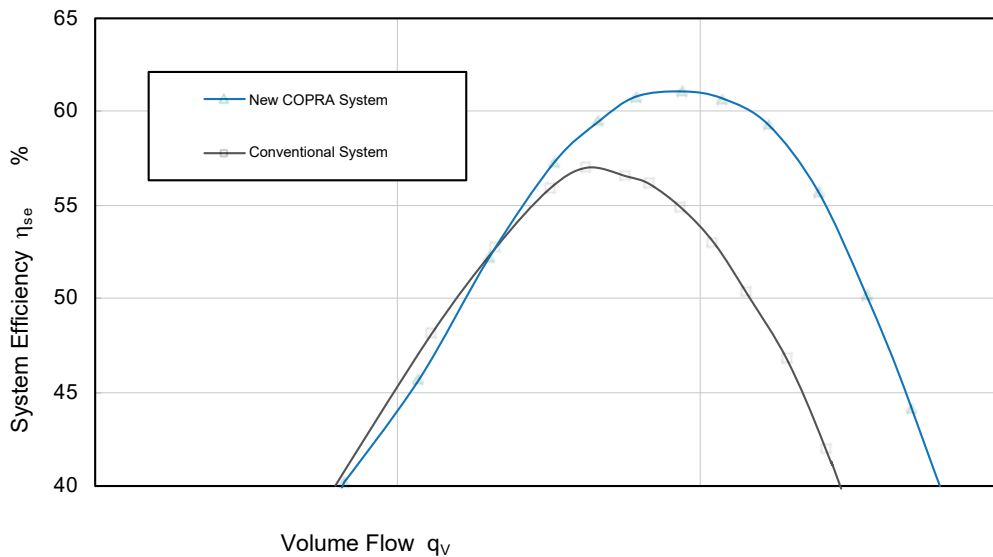

In this example, we compare VGreen Evo (TM) motor series fan with the COPRA system under otherwise identical conditions. With an installation ratio of factor 1.5 to the outer wall, in relation to the impeller diameter, COPRA™ fans achieve significantly better values, especially to the right of the optimum.

THE EASY AND SURE WAY OF SELECTING YOUR FAN!

For your Specification

Extremely short compact built-in module with highest system efficiency. Specially designed motor impeller unit. Free from aerodynamic obstructions in the inflow area. Newly developed high performance impeller manufactured automatically from high strength aluminum, step welded, with 5 backward curved blades in profiled 3D design with true airfoil. balanced statically and dynamically according to DIN ISO 21940-11. System inlet cone made of galvanized sheet steel for optimal inflow to the impeller, equipped with flow measuring device IMV as a standard feature. Extremely short internal rotor motor in highly efficient permanent magnet technology with integrated control electronics, in efficiency class IE6, functionally perfectly matched to the impeller. Continuous speed control of the Drive System by 0 ... 10 V analogue signal, or with Modbus RS485-compliant interface. Due to minimal losses and intelligent cooling concept, no additional motor cooling by air flow required. Magnets without the use of rare earths. Fan can be used in horizontal and vertical axis position. Performance data to DIN 24166 Class 1 (BS 848 Class „A“)

proSELECTA

The Fan-Configurator

On <https://www.nicotra-gebhardt.com/en/> start the interaktive online software for selecting your individual fan system.

Your Registration and login is required.



Wiring Systems

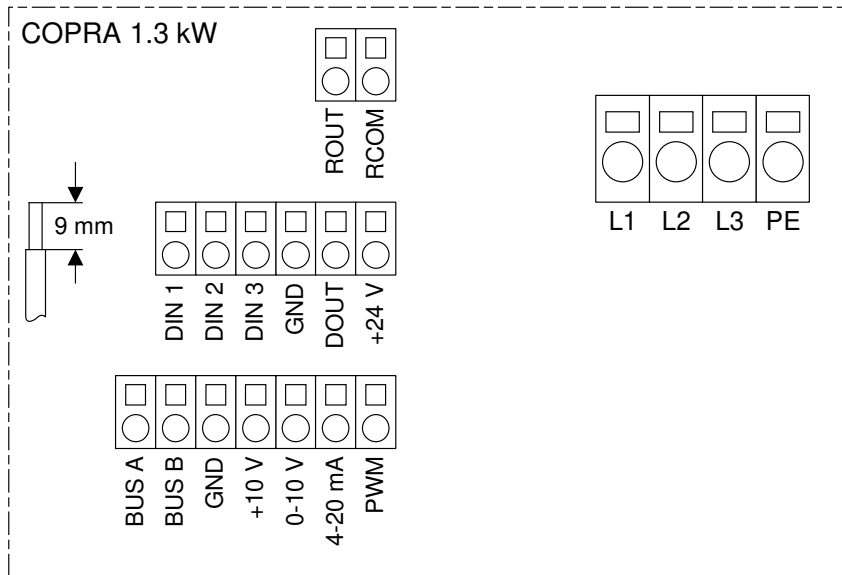

13-07-22 **640**

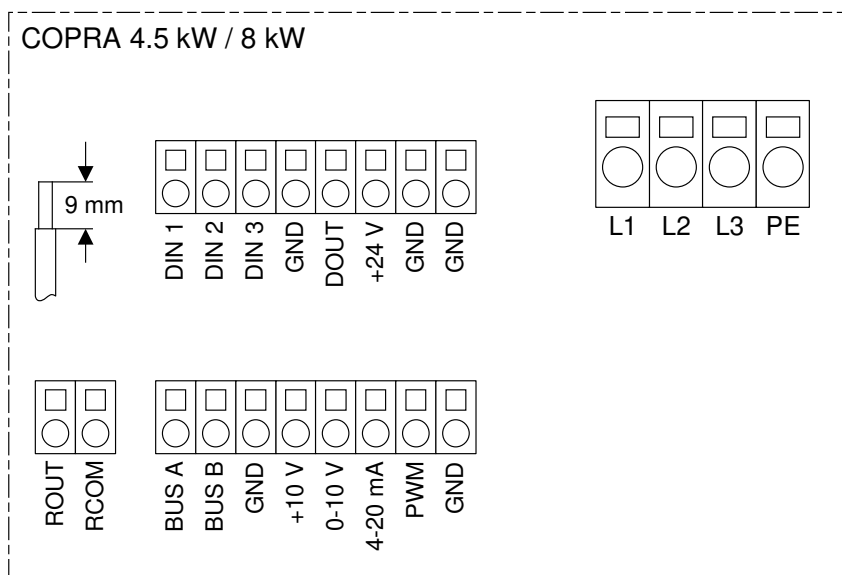

15-07-22 **641**

Performance data

Determination of the fan characteristics and performance data is conducted in "A" type of installation on a test bench certified in accordance with ISO 5801. In the diagrams of all installation sizes, the free increase in blowout pressure psF is shown relative to the volume flow qV.

The characteristics relate to a density $\rho_1 = 1.2 \text{ kg/m}^3$ of the conveying medium. Increase in pressure and drive power will alter in proportion to the density. The levels of efficiency η_{sa} specified in the characteristics relate to the full system (impeller, motor, control unit).

Noises

The measurement and analysis of noise will be conducted in accordance with DIN 45635-38 "Measuring noise in machines; fans". In the characteristics, the A sound power level LWA8 is specified as the emission level for the outlet side. The value for the inlet side LWA5 and the unweighted octave spectrum, which, for example, is required for sound absorber designs, can be determined for different operating points and rotational speeds using our fan selection program - proSELECTA II. Access to this is on www.nicotra-gebhardt.com.

Accessories

Please note: Optionally available accessories are supplied loose when ordered.

Description	Product name
Protection grid for intake	ZSG 04-0225V
Potentiometer (control range 0 ... 100 %)	EGH 01
Potentiometer with snap-in positions	EGH 04

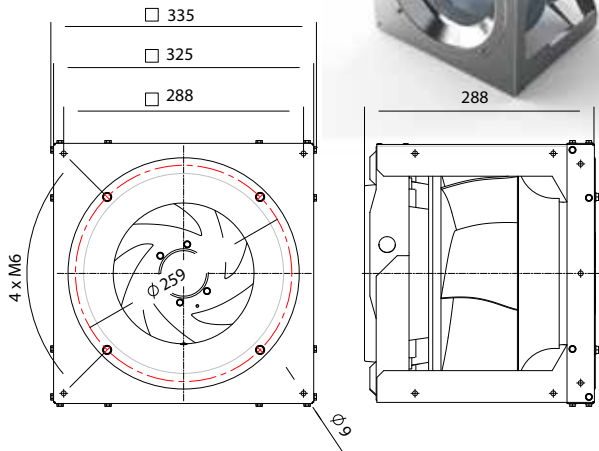

Description	Value	Dim.
Installation acc. DIN 24163 Part 1	A	
Reference density (Rho1)	1,20	kg/m ³
Medium temperature (t)	20	C
Fan weight (m) basic device without accessories	22	kg
Feed data		
Main's frequency (f _N)	50/60	Hz
Voltage (U _N)	3~200-240	V
operational limits		
Max. fan speed (n _{vmax})	4200	1/min
Max. absorbed power of the system (P _{maxS})	1,30	kW
max. current: Inverter out resp. control unit in (I _{max})	3,4	A
Temperature range for conveying medium (t _{min} ... t _{max})	-20...40	C

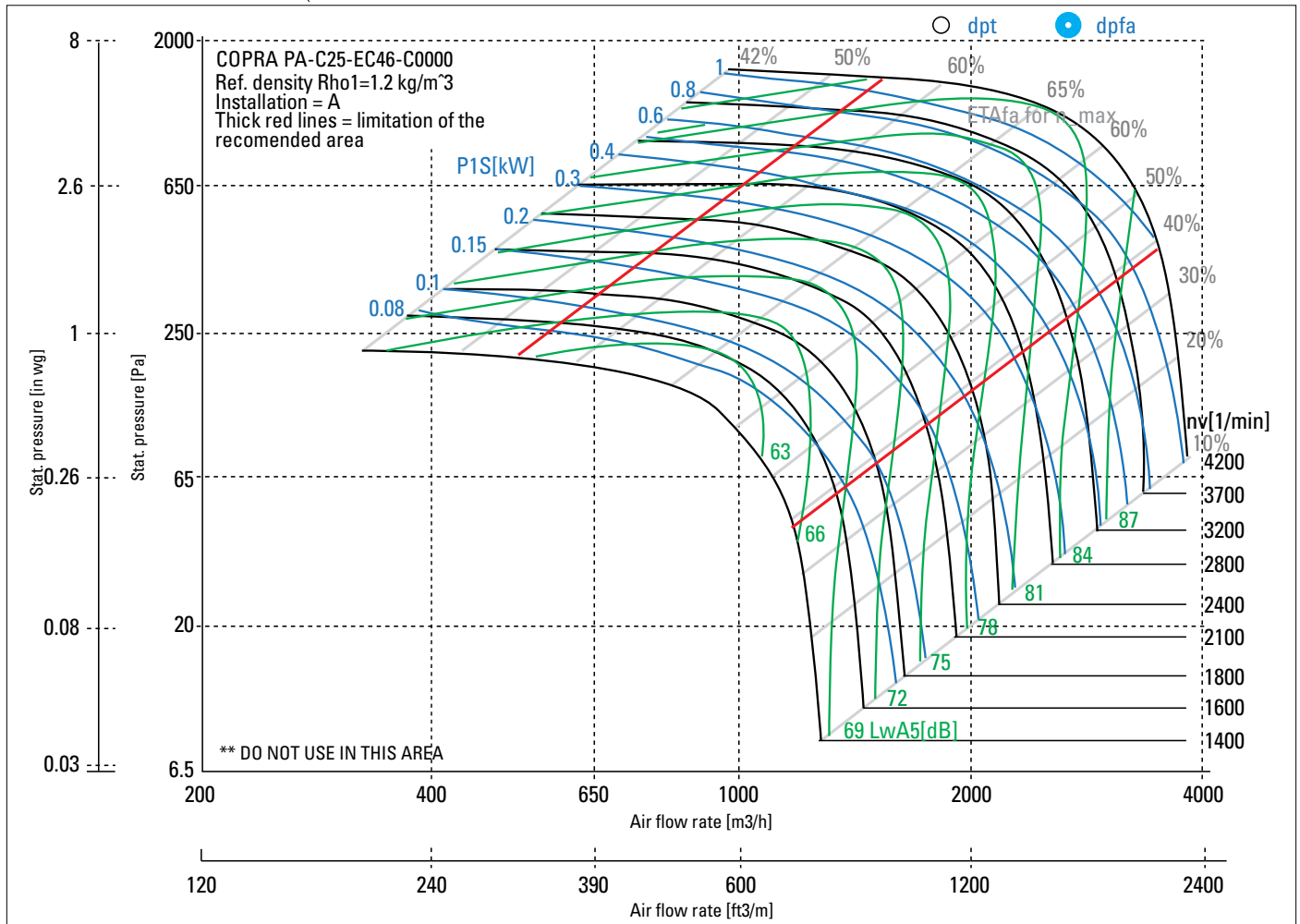

Technical Data according to ErP-REGULATION 327/2011/EU

measurement- / efficiency category A / static
 design status of VSD is integrated
 overall efficiency (ETA_{opt}) 69,9 %
 achieved efficiency grade (N_{ist}) 79,7
 required efficiency grade in 2015 (N) 62
 Year of manufacture is shown on the relevant rating plate for the product
 Manufacturer Nicotra Gebhardt GmbH, Gebhardtstr. 19-25, 74638 Waldenburg
 Type Model number PA-C25-EC46-C0000
 Air flow rate (V_{opt}) 2458 m3/h

pressure rise (dp_{opt}) 1201 Pa
 Fan speed (n_{vopt}) 4200 min⁻¹
 motor power input (P_{1opt}) 1,17 kW
 specific ratio (d_{dopt}) 1,012
 Disposal/Recycling: Information on recycling and disposal is provided in the operating instruction.
 Information on maintenance: Information on installation, operation and maintenance is provided in the operating instructions.
 Additional components: The measurements do not use components which are not part of the fan.

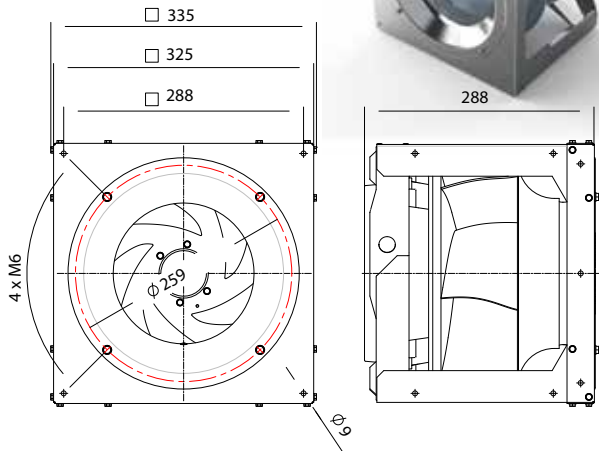

Description

Installation acc. DIN 24163 Part 1
 Reference density (Rho1)
 Medium temperature (t)
 Fan weight (m) basic device without accessories

Value	Dim.
A	
1,20	kg/m ³
20	C
22	kg

Feed data

Main's frequency (f_N)
 Voltage (U_N)

50/60	Hz
3~ 380-480	V

operational limits

Max. fan speed (n_{vmax})
 Max. absorbed power of the system (P_{maxS})
 max. current: Inverter out resp. control unit in (I_{max})
 Temperature range for conveying medium (t_{min} ... t_{max})

4200	1/min
1,30	kW
2,0	A
-20...40	C

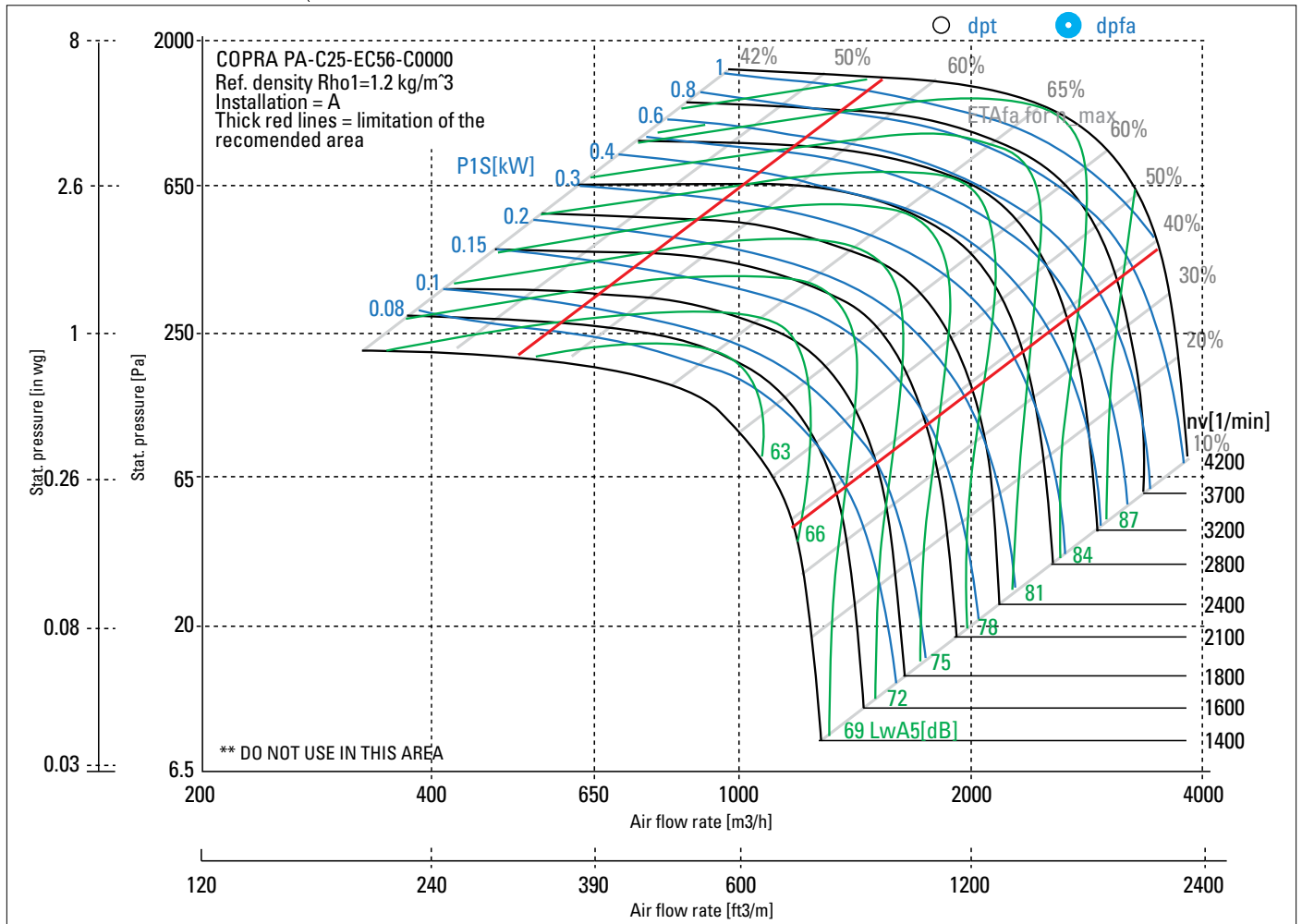

Technical Data according to ErP-REGULATION 327/2011/EU

measurement- / efficiency category A / static
 design status of VSD is integrated
 overall efficiency (ETA_{opt}) 71,0 %
 achieved efficiency grade (N_{ist}) 80,8
 required efficiency grade in 2015 (N) 62
 Year of manufacture is shown on the relevant rating plate for the product
 Manufacturer Nicotra Gebhardt GmbH, Gebhardtstr. 19-25, 74638 Waldenburg
 Type Model number PA-C25-EC56-C0000
 Air flow rate (V_{opt}) 2458 m3/h

pressure rise (dp_{opt}) 1201 Pa
 Fan speed (n_{vopt}) 4200 min⁻¹
 motor power input (P_{1opt}) 1,16 kW
 specific ratio (d_{dopt}) 1,012
 Disposal/Recycling: Information on recycling and disposal is provided in the operating instruction.
 Information on maintenance: Information on installation, operation and maintenance is provided in the operating instructions.
 Additional components: The measurements do not use components which are not part of the fan.

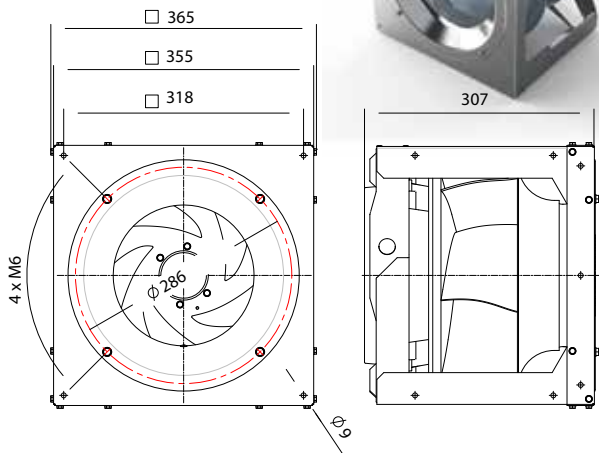

Description

Installation acc. DIN 24163 Part 1
 Reference density (Rho1)
 Medium temperature (t)
 Fan weight (m) basic device without accessories

Value	Dim.
A	
1,20	kg/m ³
20	C
22	kg

Feed data

Main's frequency (f_N)
 Voltage (U_N)

50/60	Hz
3~ 200-240	V

operational limits

Max. fan speed (n _{vmax})	3480	1/min
Max. absorbed power of the system (P _{maxS})	1,30	kW
max. current: Inverter out resp. control unit in (I _{max})	3,4	A
Temperature range for conveying medium (t _{min} ... t _{max})	-20...40	C

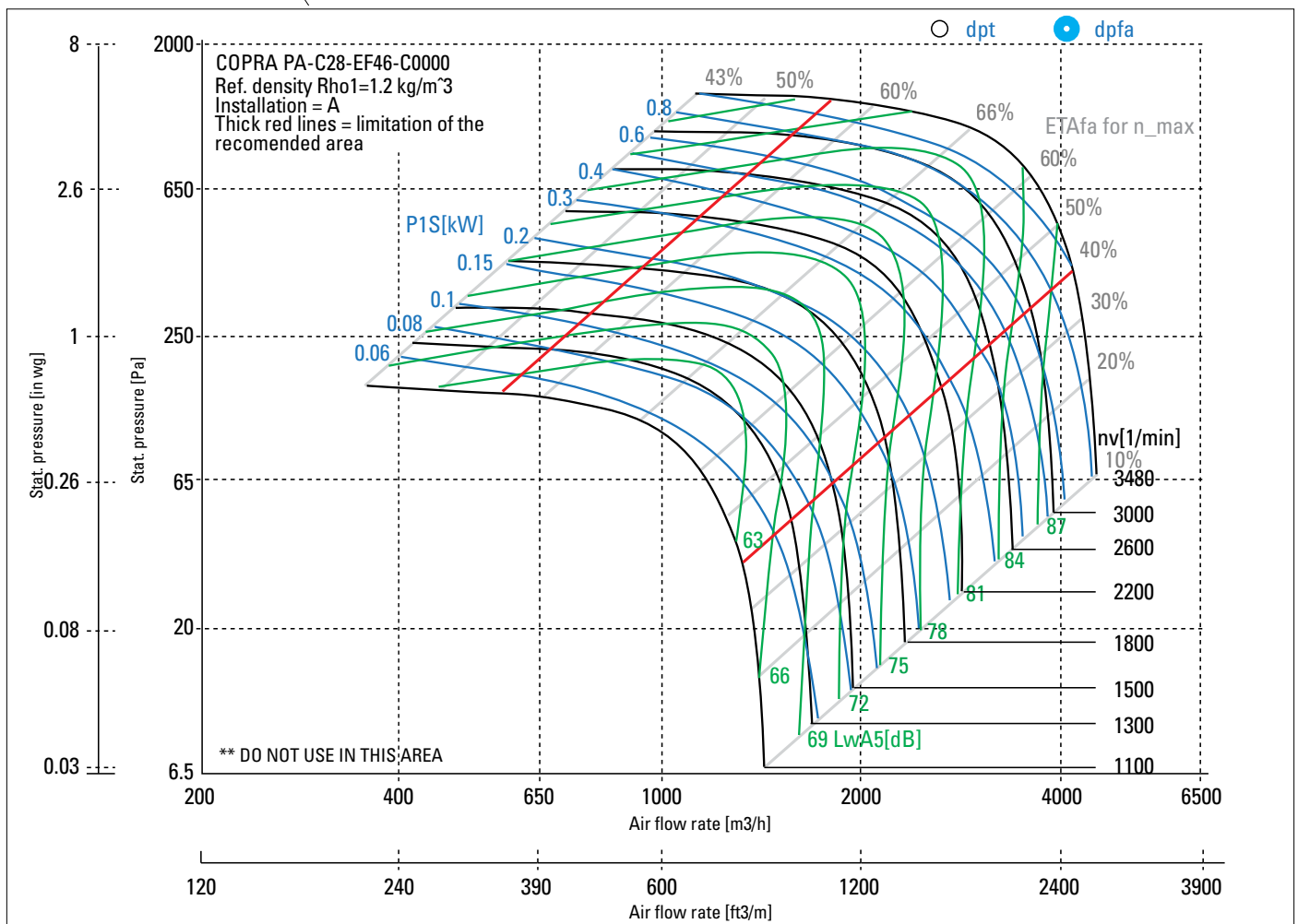

Technical Data according to ErP-REGULATION 327/2011/EU

measurement- / efficiency category A / static
 design status of VSD is integrated
 overall efficiency (ETA_{opt}) 71,0 %
 achieved efficiency grade (N_{ist}) 80,8
 required efficiency grade in 2015 (N) 62
 Year of manufacture is shown on the relevant rating plate for the product
 Manufacturer Nicotra Gebhardt GmbH, Gebhardtstr. 19-25, 74638 Waldenburg
 Type Model number PA-C28-EF46-C0000
 Air flow rate (V_{opt}) 2929 m3/h

pressure rise (dp _{opt})	1031 Pa
Fan speed (n _{vopt})	3480 min ⁻¹
motor power input (P _{1opt})	1,18 kW
specific ratio (d _{dpopt})	1,010

Disposal/Recycling: Information on recycling and disposal is provided in the operating instruction.
 Information on maintenance: Information on installation, operation and maintenance is provided in the operating instructions.
 Additional components: The measurements do not use components which are not part of the fan.

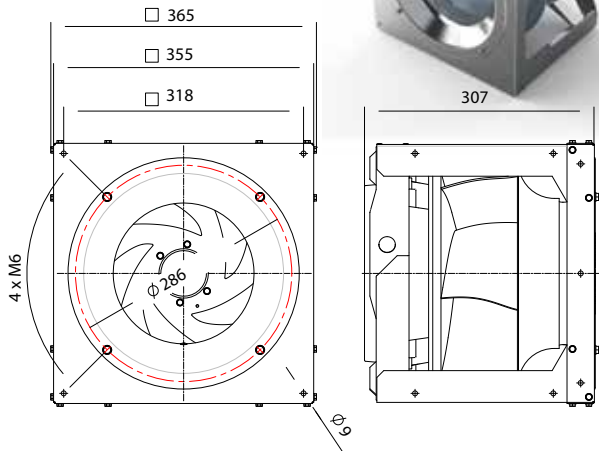

Description

Installation acc. DIN 24163 Part 1
 Reference density (Rho1)
 Medium temperature (t)
 Fan weight (m) basic device without accessories

Value	Dim.
A	
1,20	kg/m ³
20	C
22	kg

Feed data

Main's frequency (f_N)
 Voltage (U_N)

50/60	Hz
3~ 380-480	V

operational limits

Max. fan speed (n _{vmax})	3480	1/min
Max. absorbed power of the system (P _{maxS})	1,30	kW
max. current: Inverter out resp. control unit in (I _{max})	2,0	A
Temperature range for conveying medium (t _{min} ... t _{max})	-20...40	C

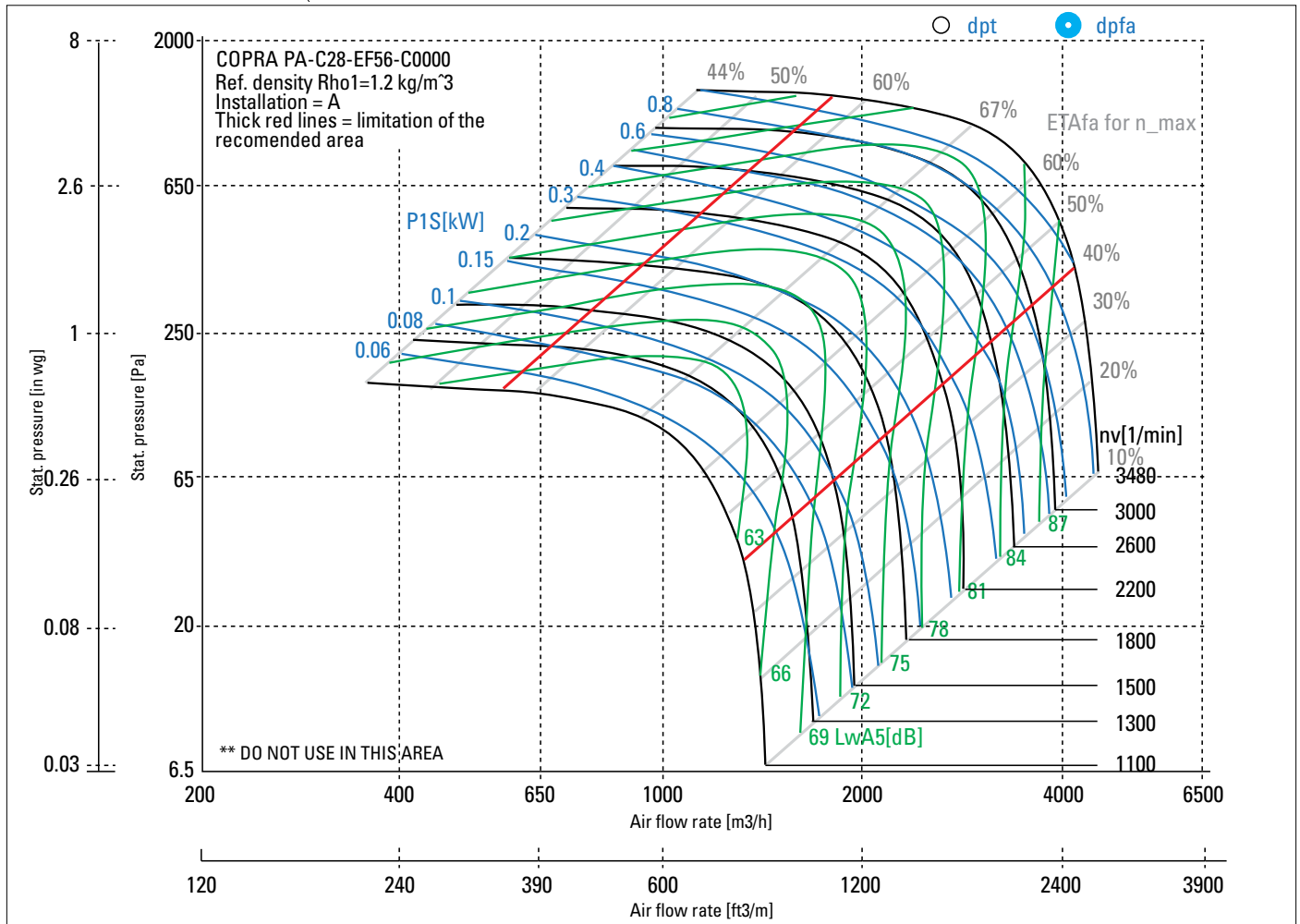

Technical Data according to ErP-REGULATION 327/2011/EU

measurement- / efficiency category A / static
 design status of VSD is integrated
 overall efficiency (ETA_{opt}) 72,1 %
 achieved efficiency grade (N_{ist}) 81,9
 required efficiency grade in 2015 (N) 62
 Year of manufacture is shown on the relevant rating plate for the product
 Manufacturer Nicotra Gebhardt GmbH, Gebhardtstr. 19-25, 74638 Waldenburg
 Type Model number PA-C28-EF56-C0000
 Air flow rate (V_{opt}) 2929 m³/h

pressure rise (dp_{opt}) 1031 Pa
 Fan speed (n_{opt}) 3480 min⁻¹
 motor power input (P_{1opt}) 1,16 kW
 specific ratio (d_{dopt}) 1,010
 Disposal/Recycling: Information on recycling and disposal is provided in the operating instruction.
 Information on maintenance: Information on installation, operation and maintenance is provided in the operating instructions.
 Additional components: The measurements do not use components which are not part of the fan.

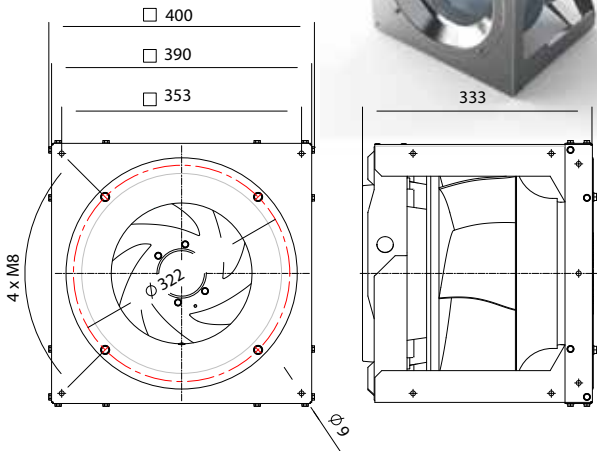

Description

Installation acc. DIN 24163 Part 1
 Reference density (Rho1)
 Medium temperature (t)
 Fan weight (m) basic device without accessories

Value	Dim.
A	
1,20	kg/m ³
20	C
24	kg

Feed data

Main's frequency (f_N)
 Voltage (U_N)

50/60	Hz
3~ 200-240	V

operational limits

Max. fan speed (n _{max})	2900	1/min
Max. absorbed power of the system (P _{maxS})	1,30	kW
max. current: Inverter out resp. control unit in (I _{max})	3,5	A
Temperature range for conveying medium (t _{min} ... t _{max})	-20...40	C

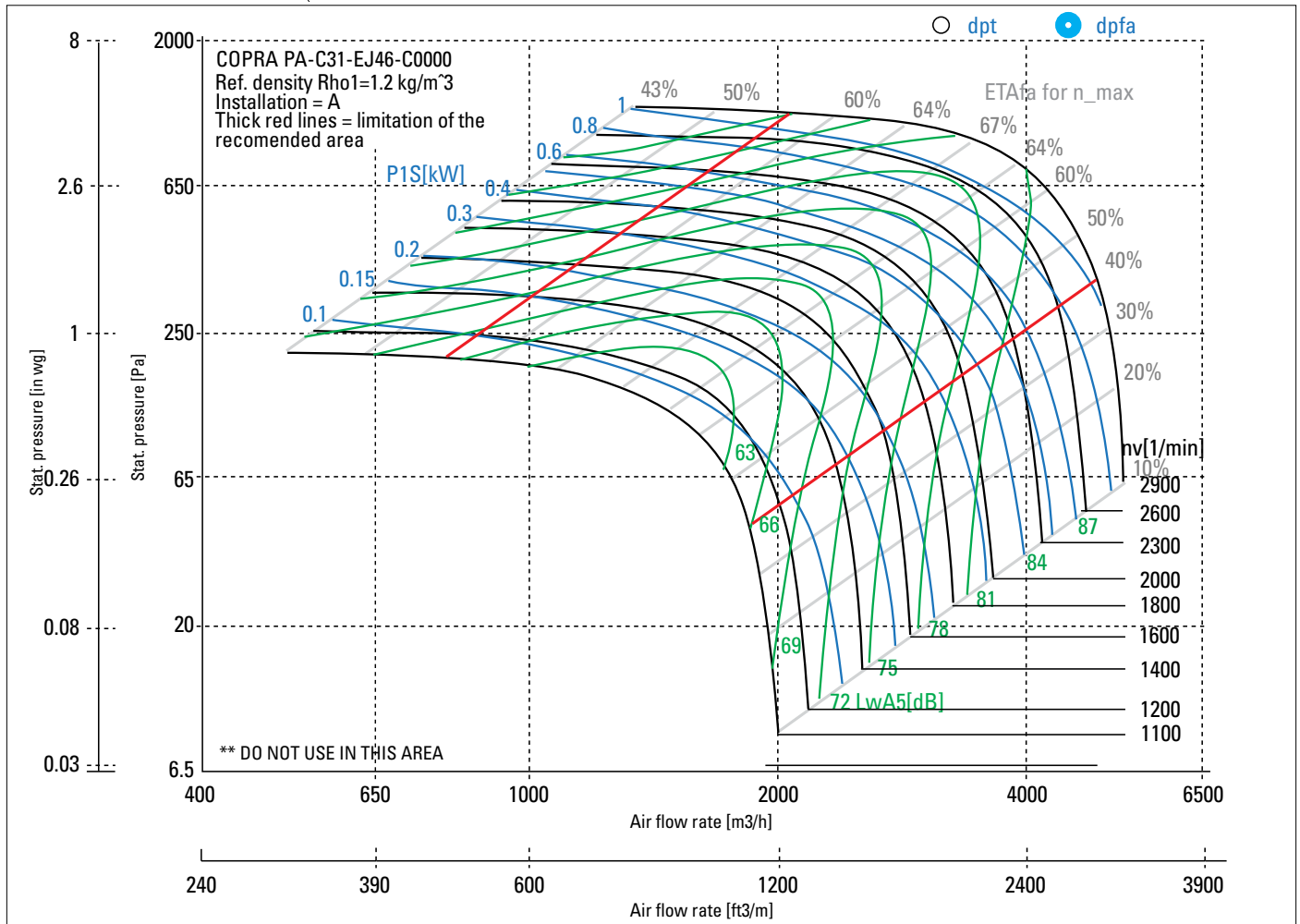

Technical Data according to ErP-REGULATION 327/2011/EU

measurement- / efficiency category A / static
 design status of VSD is integrated
 overall efficiency (ETA_{opt}) 71,1 %
 achieved efficiency grade (N_{ist}) 80,7
 required efficiency grade in 2015 (N) 62
 Year of manufacture is shown on the relevant rating plate for the product
 Manufacturer Nicotra Gebhardt GmbH, Gebhardtstr. 19-25, 74638 Waldenburg
 Type Model number PA-C31-EJ46-C0000
 Air flow rate (V_{opt}) 3435 m³/h

pressure rise (dp_{opt}) 912 Pa
 Fan speed (n_{opt}) 2900 min⁻¹
 motor power input (P_{1opt}) 1,22 kW
 specific ratio (d_{dopt}) 1,009
 Disposal/Recycling: Information on recycling and disposal is provided in the operating instruction.
 Information on maintenance: Information on installation, operation and maintenance is provided in the operating instructions.
 Additional components: The measurements do not use components which are not part of the fan.

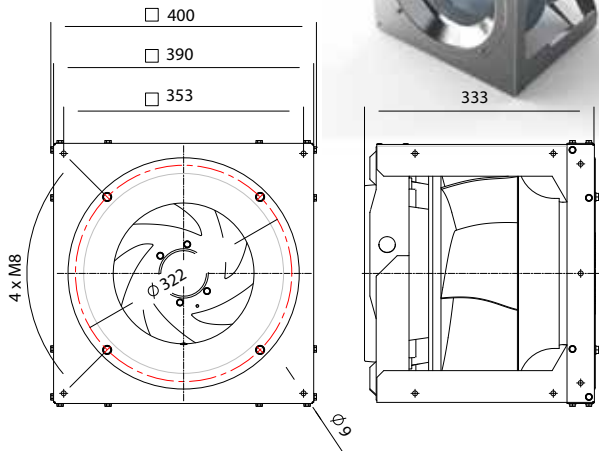

Description

Installation acc. DIN 24163 Part 1
 Reference density (Rho1)
 Medium temperature (t)
 Fan weight (m) basic device without accessories

Value	Dim.
A	
1,20	kg/m ³
20	C
24	kg

Feed data

Main's frequency (f_N)
 Voltage (U_N)

50/60	Hz
3~ 380-480	V

operational limits

Max. fan speed (n _{max})	2900	1/min
Max. absorbed power of the system (P _{maxS})	1,30	kW
max. current: Inverter out resp. control unit in (I _{max})	2,0	A
Temperature range for conveying medium (t _{min} ... t _{max})	-20...40	C

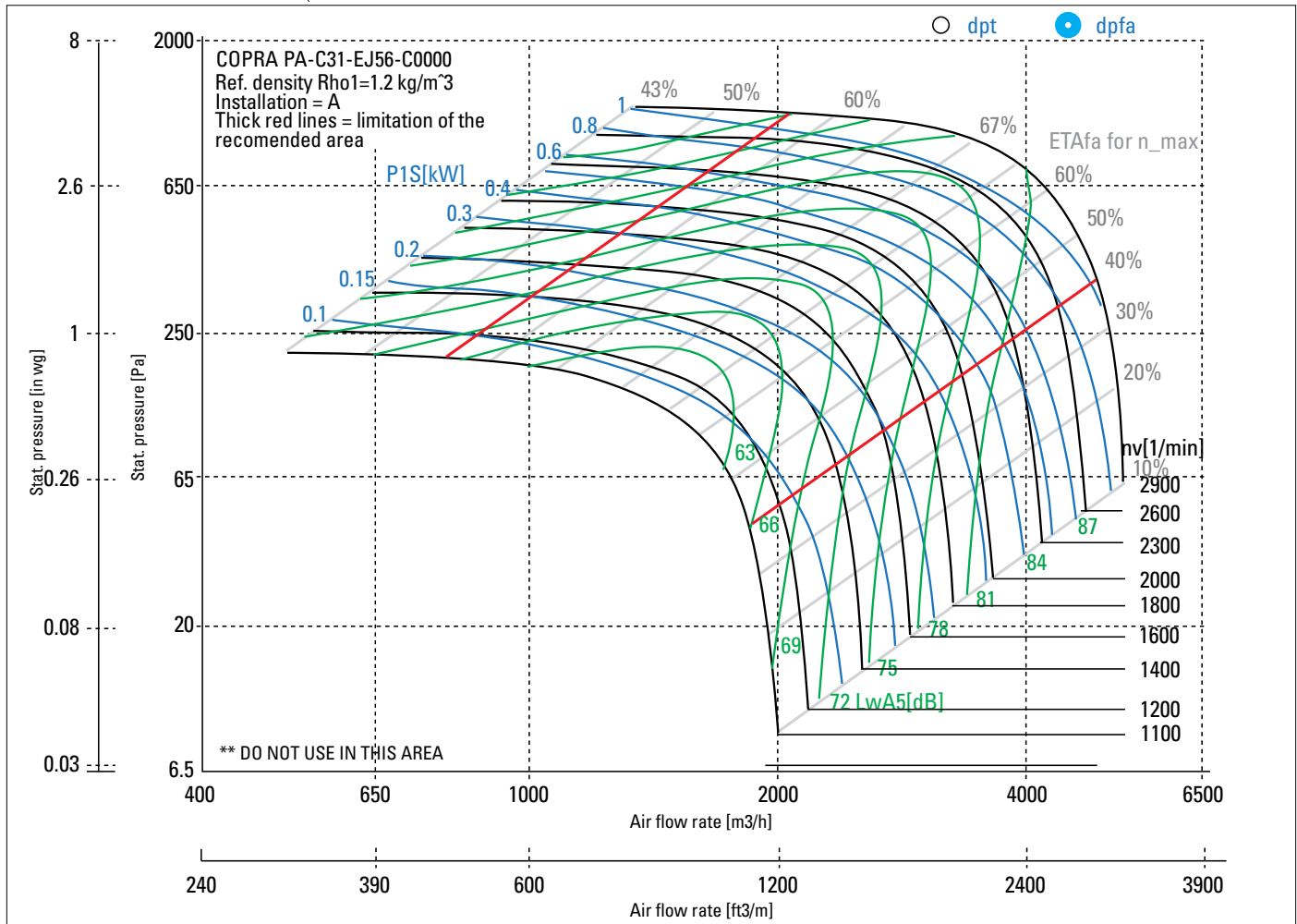

Technical Data according to ErP-REGULATION 327/2011/EU

measurement- / efficiency category A / static
 design status of VSD is integrated
 overall efficiency (ETA_{opt}) 72,0 %
 achieved efficiency grade (N_{ist}) 81,7
 required efficiency grade in 2015 (N) 62
 Year of manufacture is shown on the relevant rating plate for the product
 Manufacturer Nicotra Gebhardt GmbH, Gebhardtstr. 19-25, 74638 Waldenburg
 Type Model number PA-C31-EJ56-C0000
 Air flow rate (V_{opt}) 3435 m³/h

pressure rise (dp_{opt}) 912 Pa
 Fan speed (n_{opt}) 2900 min⁻¹
 motor power input (P_{1opt}) 1,21 kW
 specific ratio (d_{dopt}) 1,009
 Disposal/Recycling: Information on recycling and disposal is provided in the operating instruction.
 Information on maintenance: Information on installation, operation and maintenance is provided in the operating instructions.
 Additional components: The measurements do not use components which are not part of the fan.

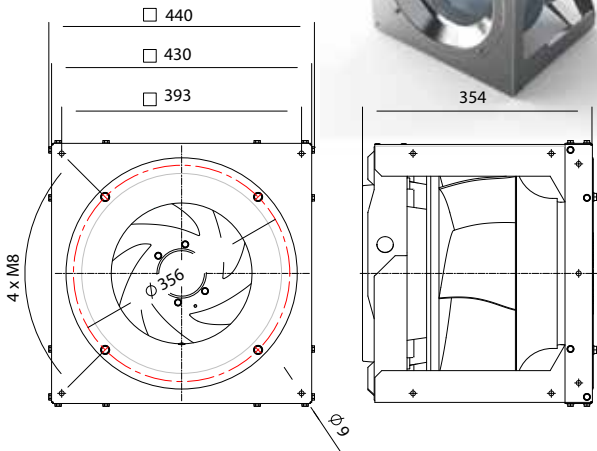

Description

Installation acc. DIN 24163 Part 1
 Reference density (Rho1)
 Medium temperature (t)
 Fan weight (m) basic device without accessories

Value	Dim.
A	
1,20	kg/m ³
20	C
26	kg

Feed data

Main's frequency (f_N)
 Voltage (U_N)

50/60	Hz
3~ 200-240	V

operational limits

Max. fan speed (n _{max})	2370	1/min
Max. absorbed power of the system (P _{maxS})	1,30	kW
max. current: Inverter out resp. control unit in (I _{max})	3,4	A
Temperature range for conveying medium (t _{min} ... t _{max})	-20...40	C

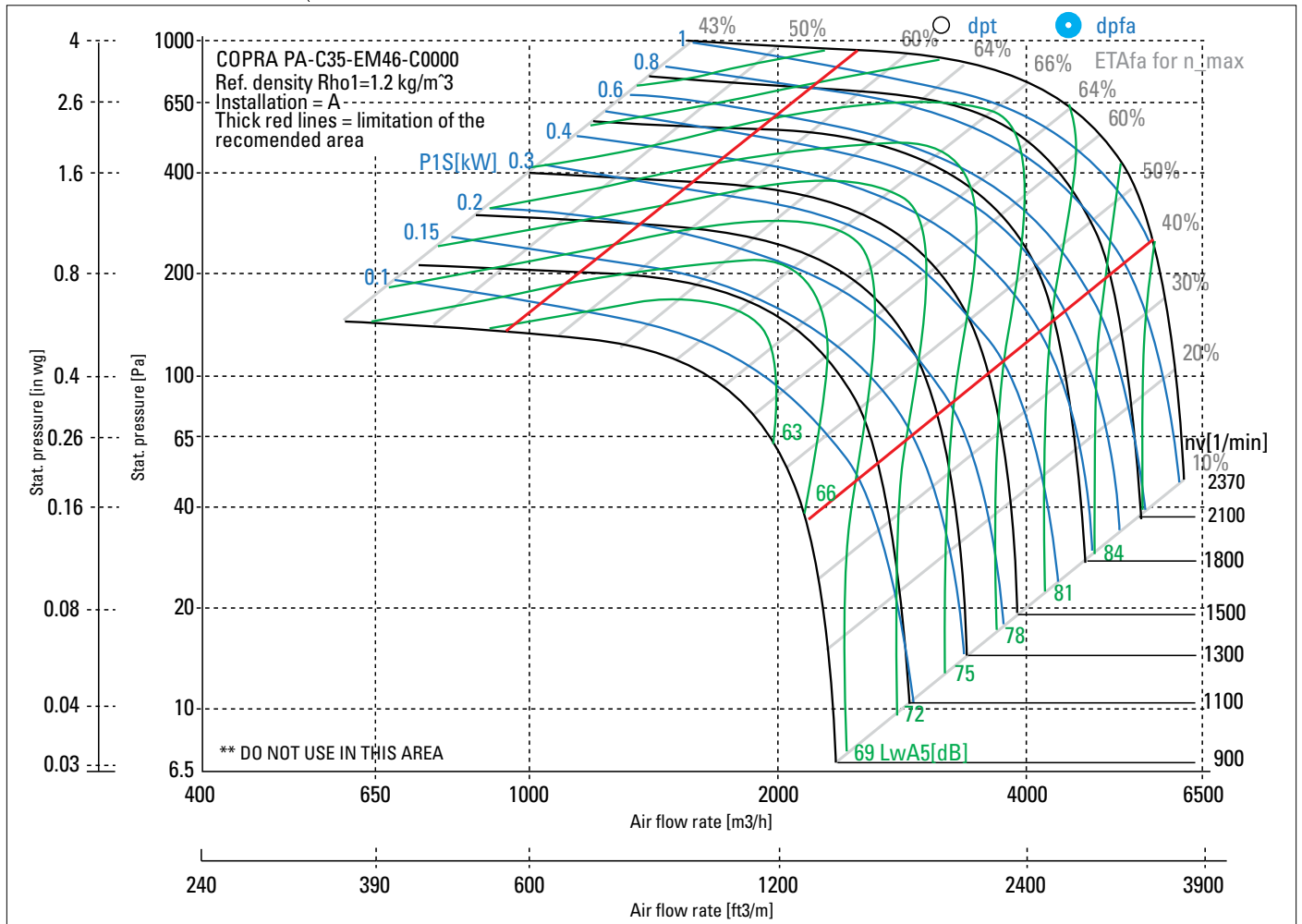

Technical Data according to ErP-REGULATION 327/2011/EU

measurement- / efficiency category A / static
 design status of VSD is integrated
 overall efficiency (ETA_{opt}) 71,0 %
 achieved efficiency grade (N_{ist}) 80,8
 required efficiency grade in 2015 (N) 62
 Year of manufacture is shown on the relevant rating plate for the product
 Manufacturer Nicotra Gebhardt GmbH, Gebhardtstr. 19-25, 74638 Waldenburg
 Type Model number PA-C35-EM46-C0000
 Air flow rate (V_{opt}) 3987 m³/h

pressure rise (dp_{opt}) 756 Pa
 Fan speed (n_{opt}) 2370 min⁻¹
 motor power input (P_{1opt}) 1,18 kW
 specific ratio (d_{dopt}) 1,008
 Disposal/Recycling: Information on recycling and disposal is provided in the operating instruction.
 Information on maintenance: Information on installation, operation and maintenance is provided in the operating instructions.
 Additional components: The measurements do not use components which are not part of the fan.

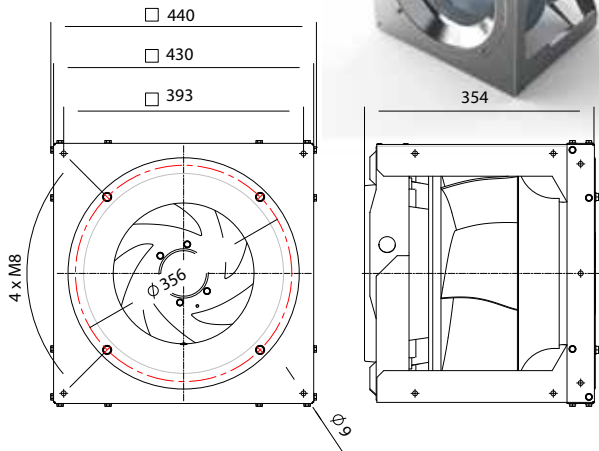

Description

Installation acc. DIN 24163 Part 1
 Reference density (Rho1)
 Medium temperature (t)
 Fan weight (m) basic device without accessories

Value	Dim.
A	
1,20	kg/m ³
20	C
26	kg

Feed data

Main's frequency (f_N)
 Voltage (U_N)

50/60	Hz
3~ 380-480	V

operational limits

Max. fan speed (n _{max})	2370	1/min
Max. absorbed power of the system (P _{maxS})	1,30	kW
max. current: Inverter out resp. control unit in (I _{max})	2,0	A
Temperature range for conveying medium (t _{min} ... t _{max})	-20...40	C

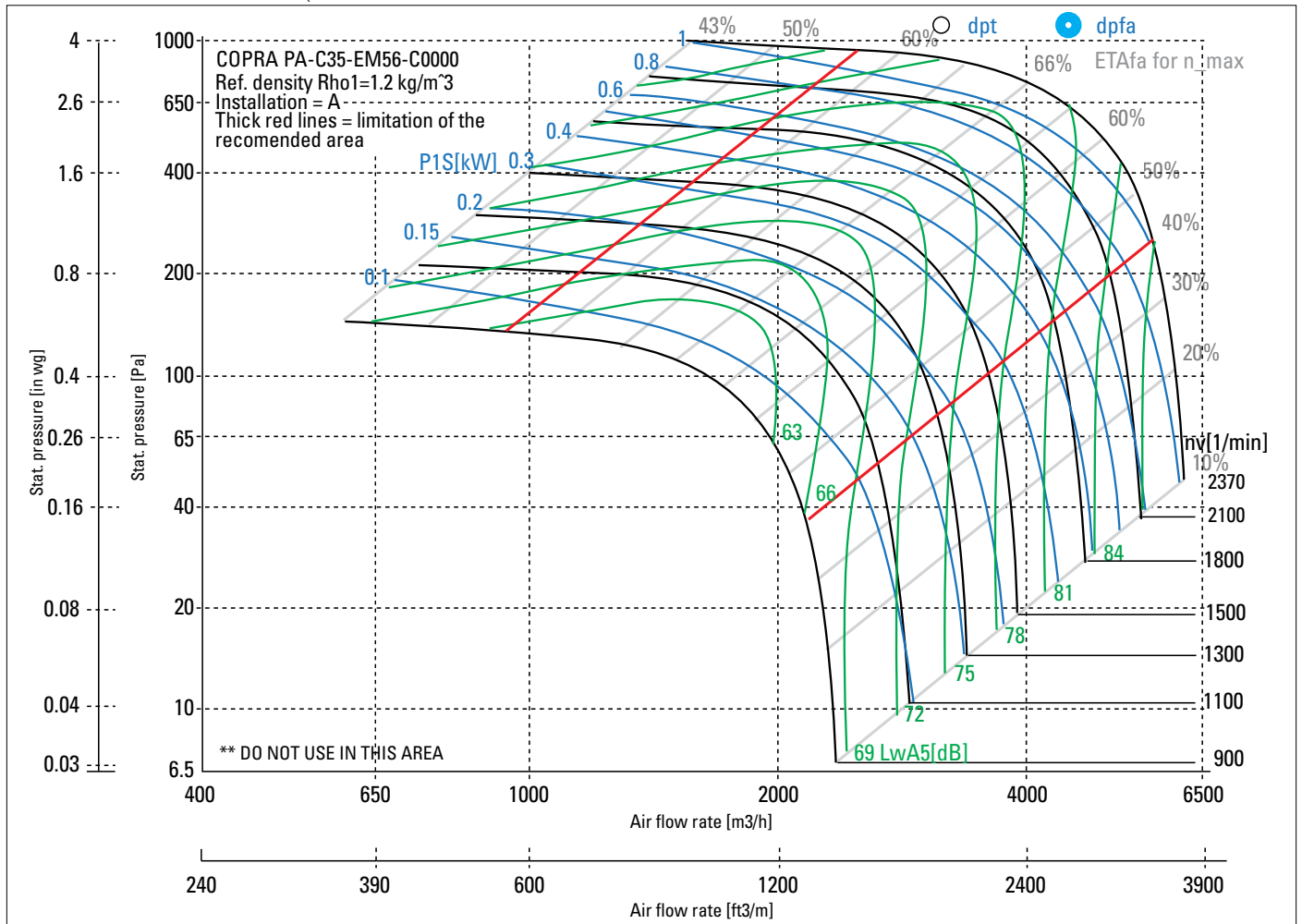

Technical Data according to ErP-REGULATION 327/2011/EU

measurement- / efficiency category A / static
 design status of VSD is integrated
 overall efficiency (ETA_{opt}) 72,1 %
 achieved efficiency grade (N_{ist}) 81,9
 required efficiency grade in 2015 (N) 62
 Year of manufacture is shown on the relevant rating plate for the product
 Manufacturer Nicotra Gebhardt GmbH, Gebhardtstr. 19-25, 74638 Waldenburg
 Type Model number PA-C35-EM56-C0000
 Air flow rate (V_{opt}) 3987 m³/h

pressure rise (dp_{opt}) 756 Pa
 Fan speed (n_{opt}) 2370 min⁻¹
 motor power input (P_{1opt}) 1,16 kW
 specific ratio (d_{dopt}) 1,008
 Disposal/Recycling: Information on recycling and disposal is provided in the operating instruction.
 Information on maintenance: Information on installation, operation and maintenance is provided in the operating instructions.
 Additional components: The measurements do not use components which are not part of the fan.

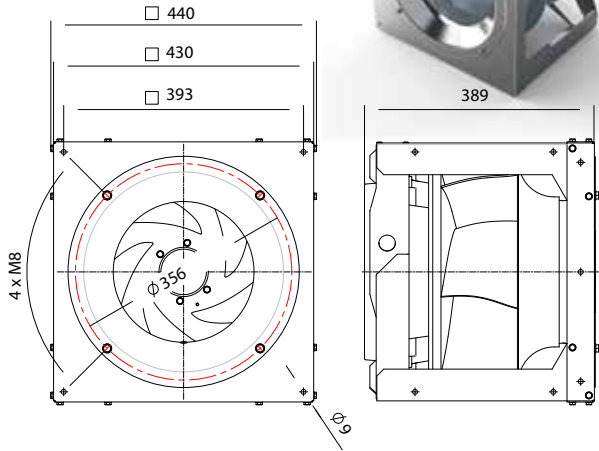

Description

Installation acc. DIN 24163 Part 1
 Reference density (Rho1)
 Medium temperature (t)
 Fan weight (m) basic device without accessories

Value	Dim.
A	
1,20	kg/m ³
20	C
33	kg

Feed data

Main's frequency (f_N)
 Voltage (U_N)

50/60	Hz
3~ 200-240	V

operational limits

Max. fan speed (n _{vmax})	3600	1/min
Max. absorbed power of the system (P _{maxS})	4,40	kW
max. current: Inverter out resp. control unit in (I _{max})	11,9	A
Temperature range for conveying medium (t _{min} ... t _{max})	-20...40	C

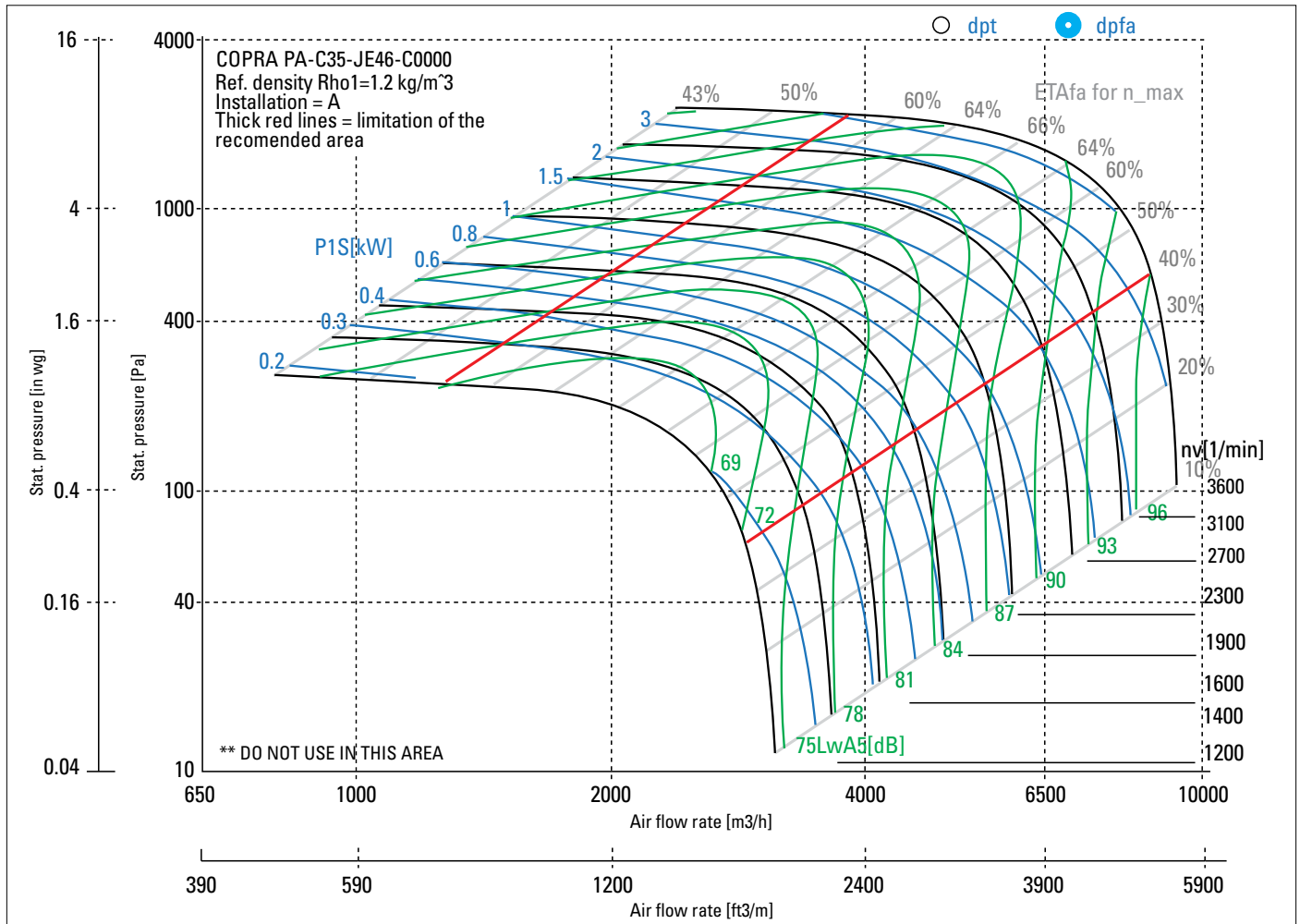

Technical Data according to ErP-REGULATION 327/2011/EU

measurement- / efficiency category A / static
 design status of VSD is integrated
 overall efficiency (ETA_{opt}) 68,9 %
 achieved efficiency grade (N_{ist}) 72,7
 required efficiency grade in 2015 (N) 62
 Year of manufacture is shown on the relevant rating plate for the product
 Manufacturer Nicotra Gebhardt GmbH, Gebhardtstr. 19-25, 74638 Waldenburg
 Type Model number PA-C35-JE46-C0000
 Air flow rate (V_{opt}) 6104 m3/h

pressure rise (dp_{opt}) 1762 Pa
 Fan speed (n_{opt}) 3600 min⁻¹
 motor power input (P_{1opt}) 4,34 kW
 specific ratio (d_{dopt}) 1,018

Disposal/Recycling: Information on recycling and disposal is provided in the operating instruction.
 Information on maintenance: Information on installation, operation and maintenance is provided in the operating instructions.
 Additional components: The measurements do not use components which are not part of the fan.

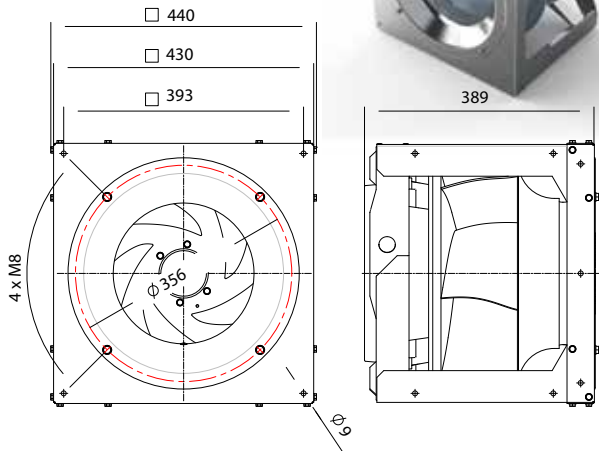

Description	Value	Dim.
Installation acc. DIN 24163 Part 1	A	
Reference density (Rho1)	1,20	kg/m ³
Medium temperature (t)	20	C
Fan weight (m) basic device without accessories	33	kg
Feed data		
Main's frequency (f _N)	50/60	Hz
Voltage (U _N)	3~ 380-480	V
operational limits		
Max. fan speed (n _{vmax})	3600	1/min
Max. absorbed power of the system (P _{maxS})	4,40	kW
max. current: Inverter out resp. control unit in (I _{max})	6,8	A
Temperature range for conveying medium (t _{min} ... t _{max})	-20...40	C

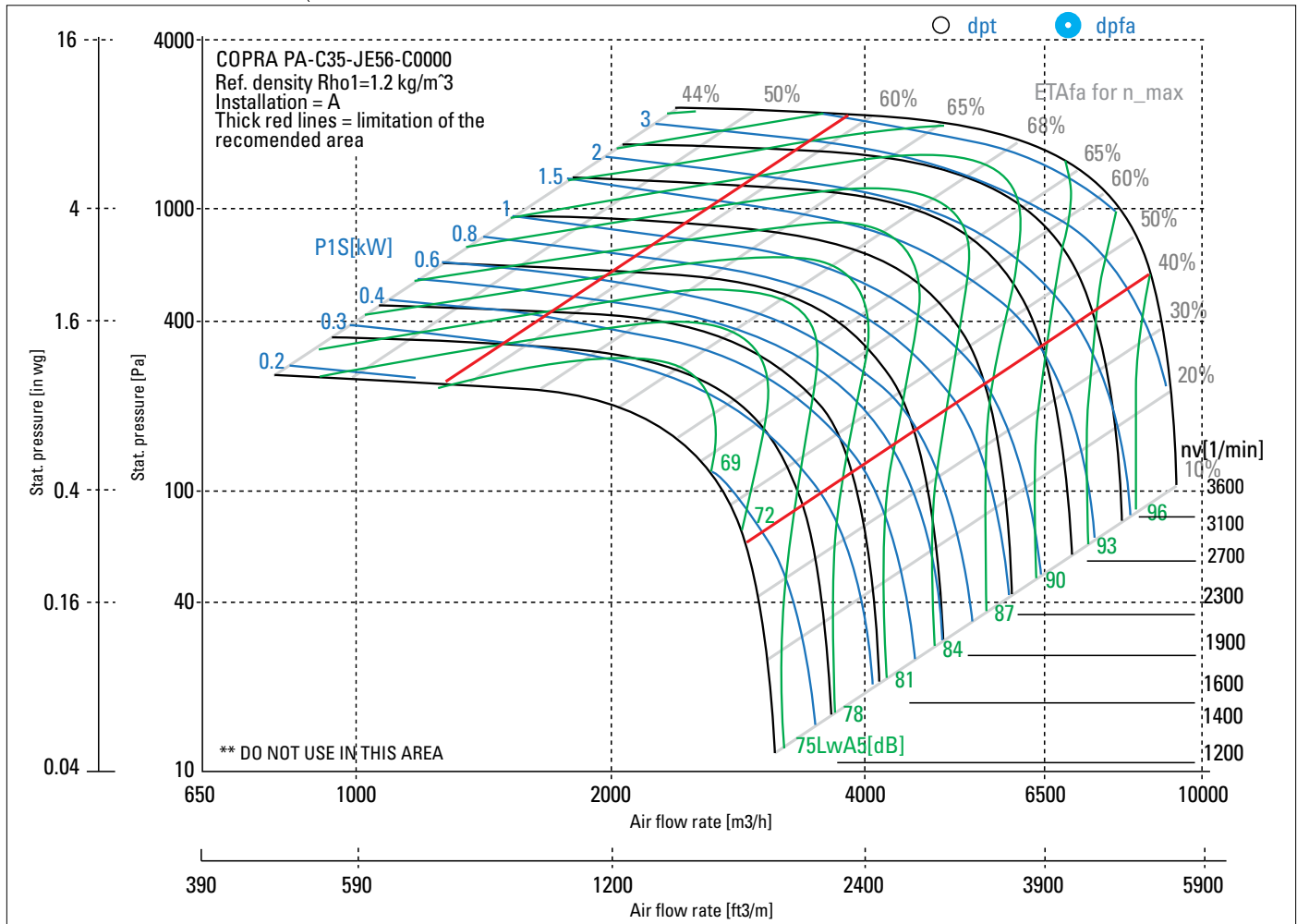

Technical Data according to ErP-REGULATION 327/2011/EU

measurement- / efficiency category A / static
 design status of VSD is integrated
 overall efficiency (ETA_{opt}) 71,0 %
 achieved efficiency grade (N_{ist}) 74,9
 required efficiency grade in 2015 (N) 62
 Year of manufacture is shown on the relevant rating plate for the product
 Manufacturer Nicotra Gebhardt GmbH, Gebhardtstr. 19-25, 74638 Waldenburg
 Type Model number PA-C35-JE56-C0000
 Air flow rate (V_{opt}) 6104 m³/h

pressure rise (dp_{opt}) 1762 Pa
 Fan speed (n_{opt}) 3600 min⁻¹
 motor power input (P_{1opt}) 4,21 kW
 specific ratio (d_{dopt}) 1,018

Disposal/Recycling: Information on recycling and disposal is provided in the operating instruction.
 Information on maintenance: Information on installation, operation and maintenance is provided in the operating instructions.
 Additional components: The measurements do not use components which are not part of the fan.

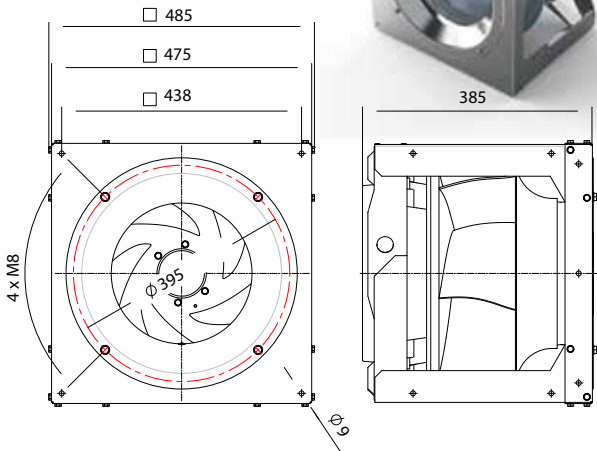

Description

Installation acc. DIN 24163 Part 1
 Reference density (Rho1)
 Medium temperature (t)
 Fan weight (m) basic device without accessories

Value	Dim.
A	
1,20	kg/m ³
20	C
27	kg

Feed data

Main's frequency (f_N)
 Voltage (U_N)

50/60	Hz
3~ 200-240	V

operational limits

Max. fan speed (n _{vmax})	1970	1/min
Max. absorbed power of the system (P _{maxS})	1,30	kW
max. current: Inverter out resp. control unit in (I _{max})	3,4	A
Temperature range for conveying medium (t _{min} ... t _{max})	-20...40	C

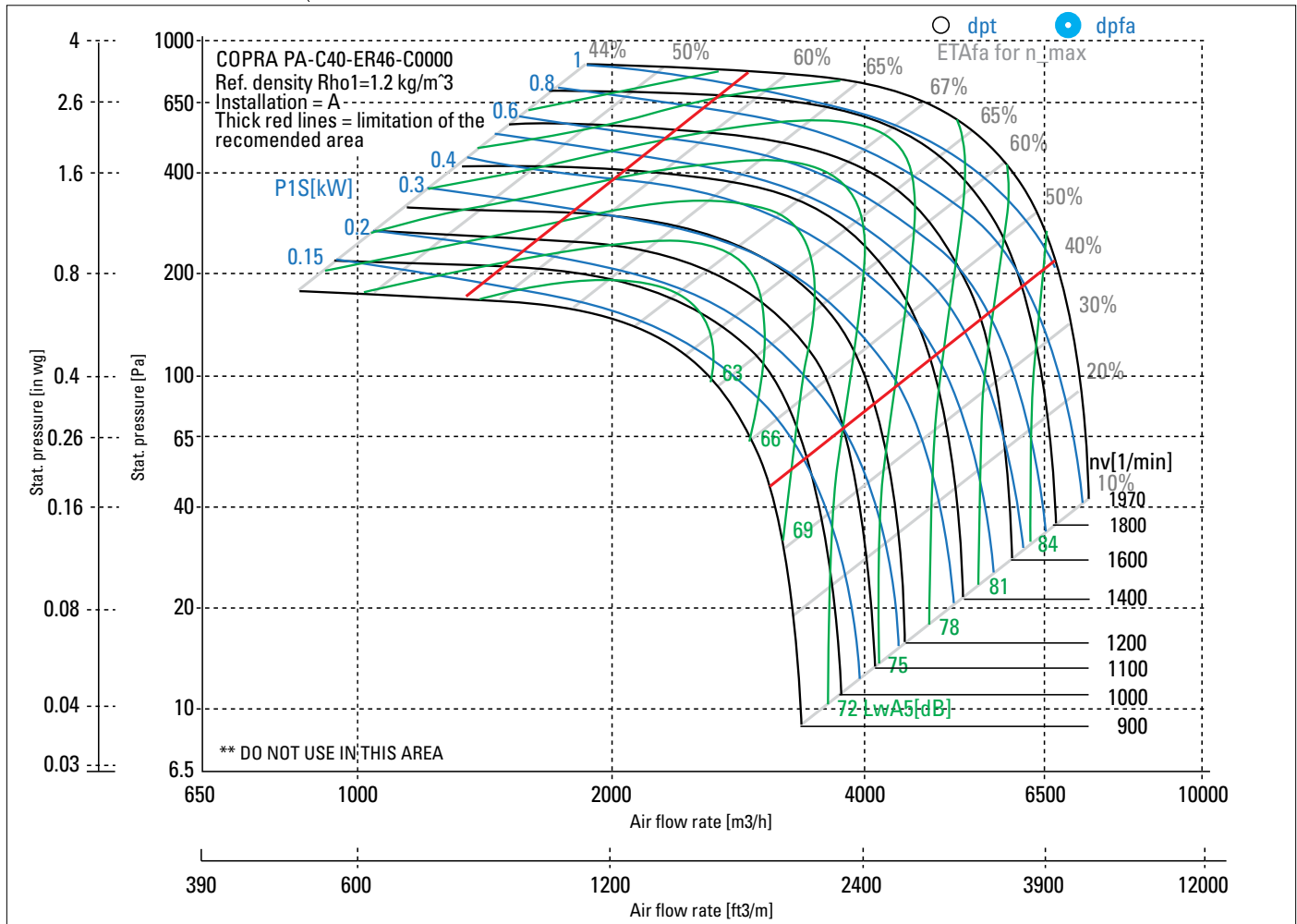

Technical Data according to ErP-REGULATION 327/2011/EU

measurement- / efficiency category A / static
 design status of VSD is integrated
 overall efficiency (ETA_{opt}) 72,5 %
 achieved efficiency grade (N_{ist}) 82,3
 required efficiency grade in 2015 (N) 62
 Year of manufacture is shown on the relevant rating plate for the product
 Manufacturer Nicotra Gebhardt GmbH, Gebhardtstr. 19-25, 74638 Waldenburg
 Type Model number PA-C40-ER46-C0000
 Air flow rate (V_{opt}) 4685 m³/h

pressure rise (dp_{opt}) 656 Pa
 Fan speed (n_{vopt}) 1970 min⁻¹
 motor power input (P_{1opt}) 1,18 kW
 specific ratio (d_{dopt}) 1,007
 Disposal/Recycling: Information on recycling and disposal is provided in the operating instruction.
 Information on maintenance: Information on installation, operation and maintenance is provided in the operating instructions.
 Additional components: The measurements do not use components which are not part of the fan.

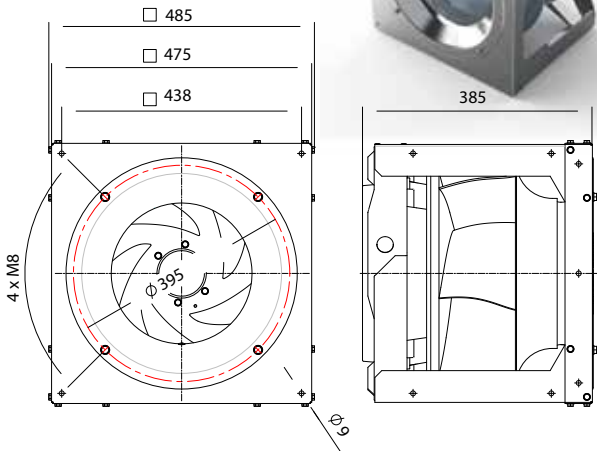

Description

Installation acc. DIN 24163 Part 1
 Reference density (Rho1)
 Medium temperature (t)
 Fan weight (m) basic device without accessories

Value	Dim.
A	
1,20	kg/m ³
20	C
27	kg

Feed data

Main's frequency (f_N)
 Voltage (U_N)

50/60	Hz
3~ 380-480	V

operational limits

Max. fan speed (n _{vmax})	1970	1/min
Max. absorbed power of the system (P _{maxS})	1,30	kW
max. current: Inverter out resp. control unit in (I _{max})	2,0	A
Temperature range for conveying medium (t _{min} ... t _{max})	-20...40	C

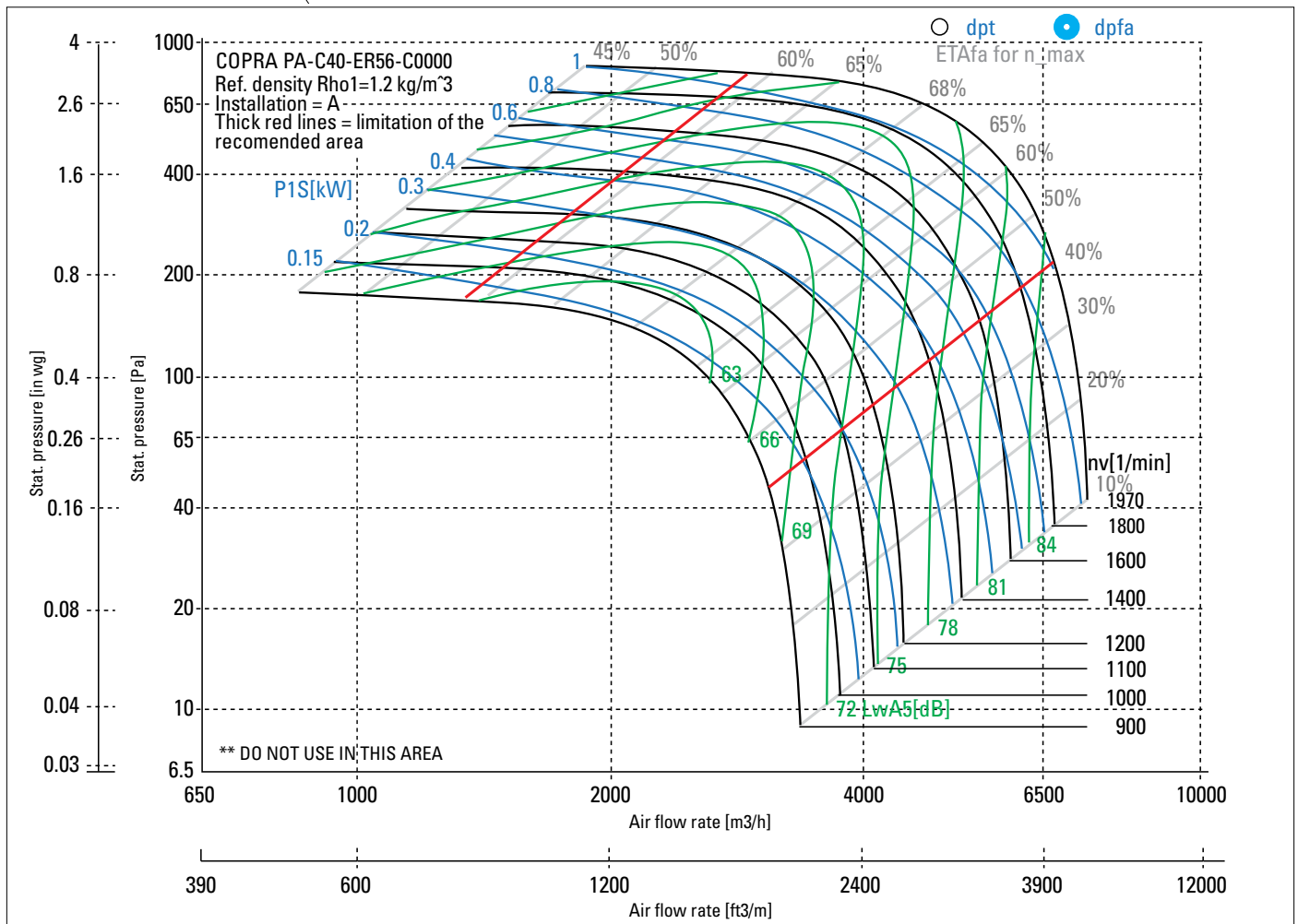

Technical Data according to ErP-REGULATION 327/2011/EU

measurement- / efficiency category A / static
 design status of VSD is integrated
 overall efficiency (ETA_{opt}) 74,0 %
 achieved efficiency grade (N_{ist}) 83,9
 required efficiency grade in 2015 (N) 62
 Year of manufacture is shown on the relevant rating plate for the product
 Manufacturer Nicotra Gebhardt GmbH, Gebhardtstr. 19-25, 74638 Waldenburg
 Type Model number PA-C40-ER56-C0000
 Air flow rate (V_{opt}) 4685 m³/h

pressure rise (dp_{opt}) 656 Pa
 Fan speed (n_{vopt}) 1970 min⁻¹
 motor power input (P_{1opt}) 1,15 kW
 specific ratio (d_{dopt}) 1,007
 Disposal/Recycling: Information on recycling and disposal is provided in the operating instruction.
 Information on maintenance: Information on installation, operation and maintenance is provided in the operating instructions.
 Additional components: The measurements do not use components which are not part of the fan.

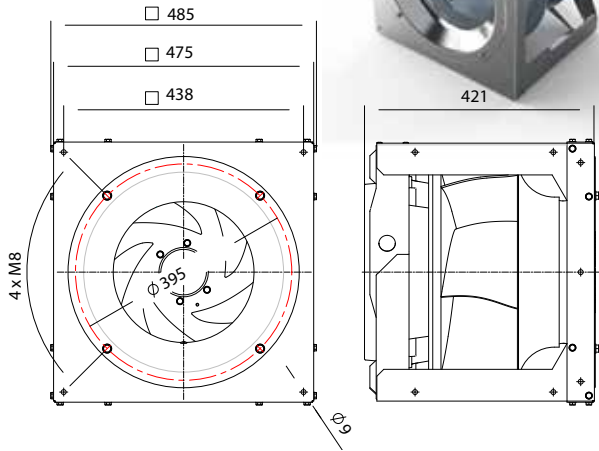

Description

Installation acc. DIN 24163 Part 1
 Reference density (Rho1)
 Medium temperature (t)
 Fan weight (m) basic device without accessories

Value	Dim.
A	
1,20	kg/m ³
20	C
36	kg

Feed data

Main's frequency (f_N)
 Voltage (U_N)

50/60	Hz
3~ 200-240	V

operational limits

Max. fan speed (n_{vmax})
 Max. absorbed power of the system (P_{maxS})
 max. current: Inverter out resp. control unit in (I_{max})
 Temperature range for conveying medium (t_{min} ... t_{max})

2980	1/min
4,40	kW
11,8	A
-20...40	C

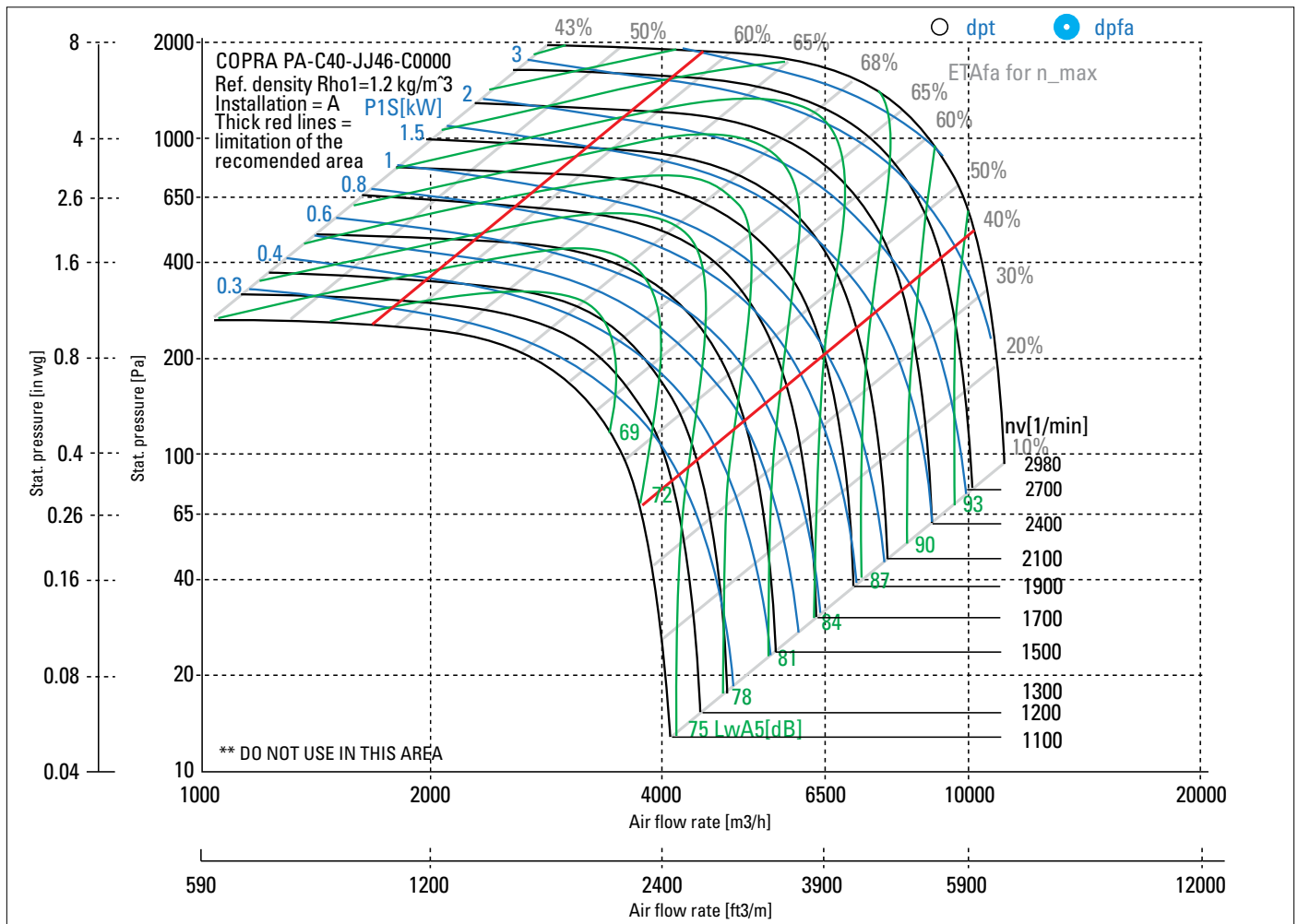

Technical Data according to ErP-REGULATION 327/2011/EU

measurement- / efficiency category A / static
 design status of VSD is integrated
 overall efficiency (ETA_{opt}) 70,6 %
 achieved efficiency grade (N_{ist}) 74,5
 required efficiency grade in 2015 (N) 62
 Year of manufacture is shown on the relevant rating plate for the product
 Manufacturer Nicotra Gebhardt GmbH, Gebhardtstr. 19-25, 74638 Waldenburg
 Type Model number PA-C40-JJ46-C0000
 Air flow rate (V_{opt}) 7115 m3/h

pressure rise (dp_{opt}) 1529 Pa
 Fan speed (n_{vopt}) 2980 min⁻¹
 motor power input (P_{1opt}) 4,28 kW
 specific ratio (d_{dopt}) 1,015
 Disposal/Recycling: Information on recycling and disposal is provided in the operating instruction.
 Information on maintenance: Information on installation, operation and maintenance is provided in the operating instructions.
 Additional components: The measurements do not use components which are not part of the fan.

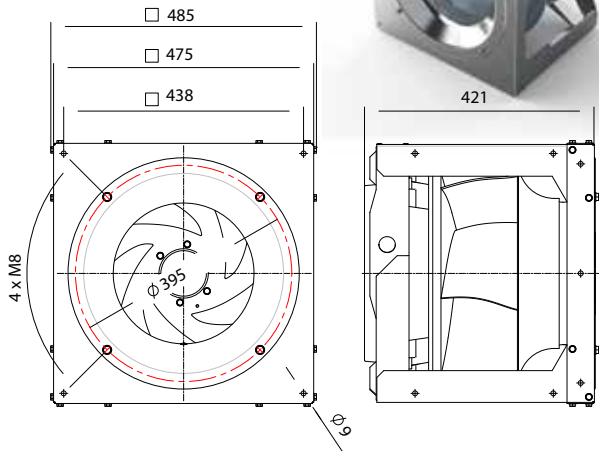

Description

Installation acc. DIN 24163 Part 1
 Reference density (Rho1)
 Medium temperature (t)
 Fan weight (m) basic device without accessories

Value	Dim.
A	
1,20	kg/m ³
20	C
36	kg

Feed data

Main's frequency (f_N)
 Voltage (U_N)

50/60	Hz
3~ 380-480	V

operational limits

Max. fan speed (n_{max})
 Max. absorbed power of the system (P_{maxS})
 max. current: Inverter out resp. control unit in (I_{max})
 Temperature range for conveying medium (t_{min} ... t_{max})

2980	1/min
4,40	kW
6,8	A
-20...40	C

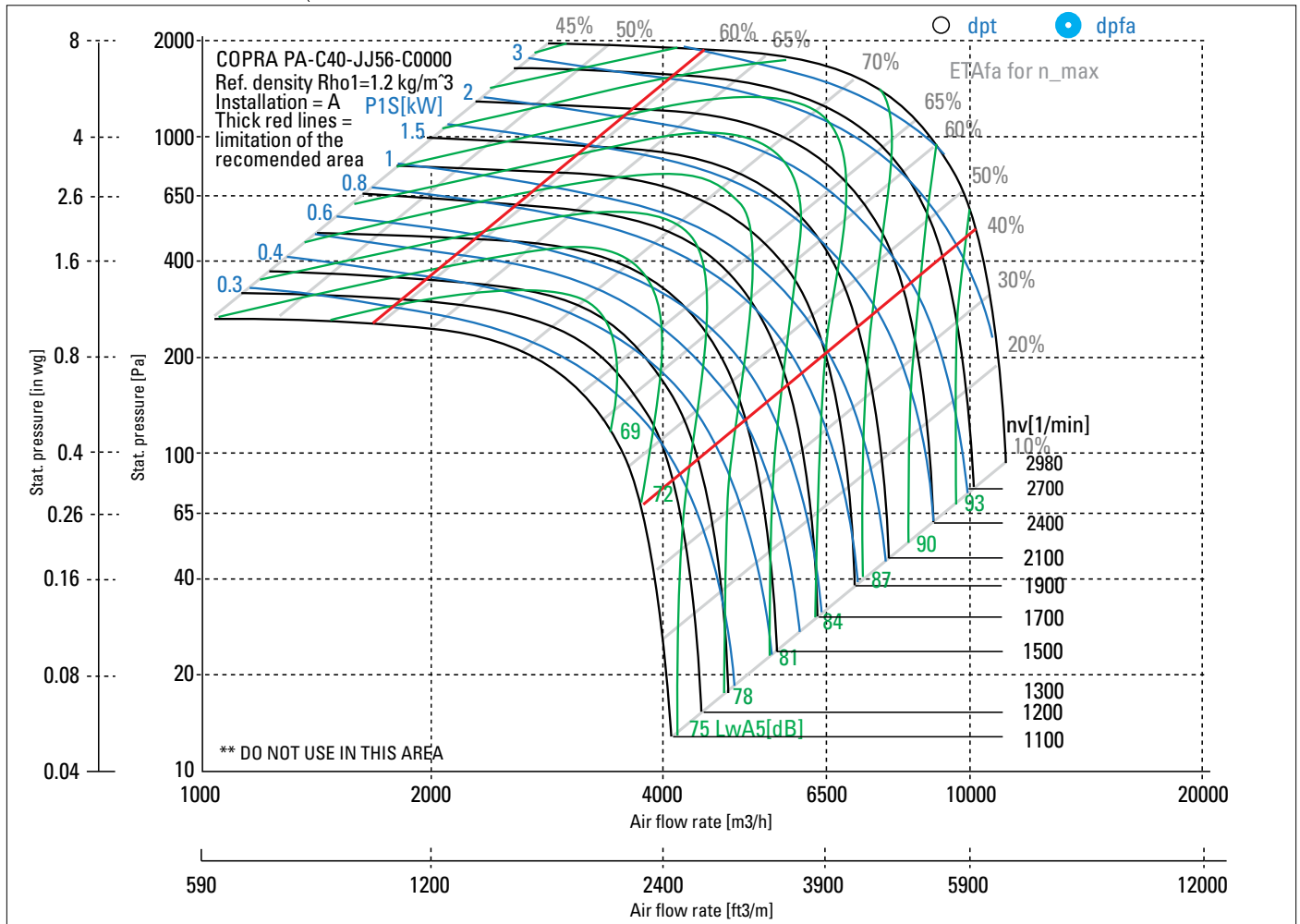

Technical Data according to ErP-REGULATION 327/2011/EU

measurement- / efficiency category A / static
 design status of VSD is integrated
 overall efficiency (ETA_{opt}) 72,8 %
 achieved efficiency grade (N_{ist}) 76,8
 required efficiency grade in 2015 (N) 62
 Year of manufacture is shown on the relevant rating plate for the product
 Manufacturer Nicotra Gebhardt GmbH, Gebhardtstr. 19-25, 74638 Waldenburg
 Type Model number PA-C40-JJ56-C0000
 Air flow rate (V_{opt}) 7115 m3/h

pressure rise (dp_{opt}) 1529 Pa
 Fan speed (n_{opt}) 2980 min⁻¹
 motor power input (P_{1opt}) 4,15 kW
 specific ratio (d_{dopt}) 1,015
 Disposal/Recycling: Information on recycling and disposal is provided in the operating instruction.
 Information on maintenance: Information on installation, operation and maintenance is provided in the operating instructions.
 Additional components: The measurements do not use components which are not part of the fan.

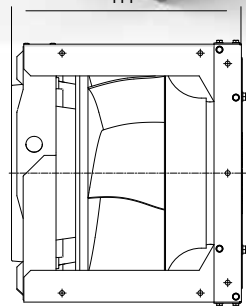
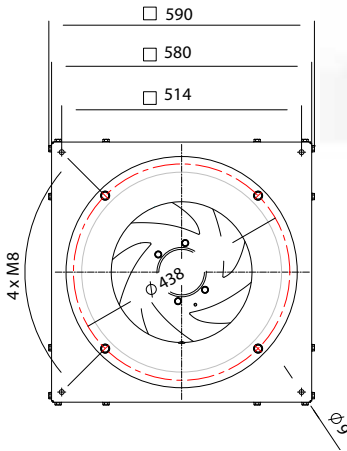

Description

Installation acc. DIN 24163 Part 1
 Reference density (Rho1)
 Medium temperature (t)
 Fan weight (m) basic device without accessories

Value	Dim.
A	
1,20	kg/m ³
20	C
33	kg

Feed data

Main's frequency (f_N)
 Voltage (U_N)

50/60	Hz
3~ 200-240	V

operational limits

Max. fan speed (n _{vmax})	1620	1/min
Max. absorbed power of the system (P _{maxS})	1,30	kW
max. current: Inverter out resp. control unit in (I _{max})	3,4	A
Temperature range for conveying medium (t _{min} ... t _{max})	-20...40	C

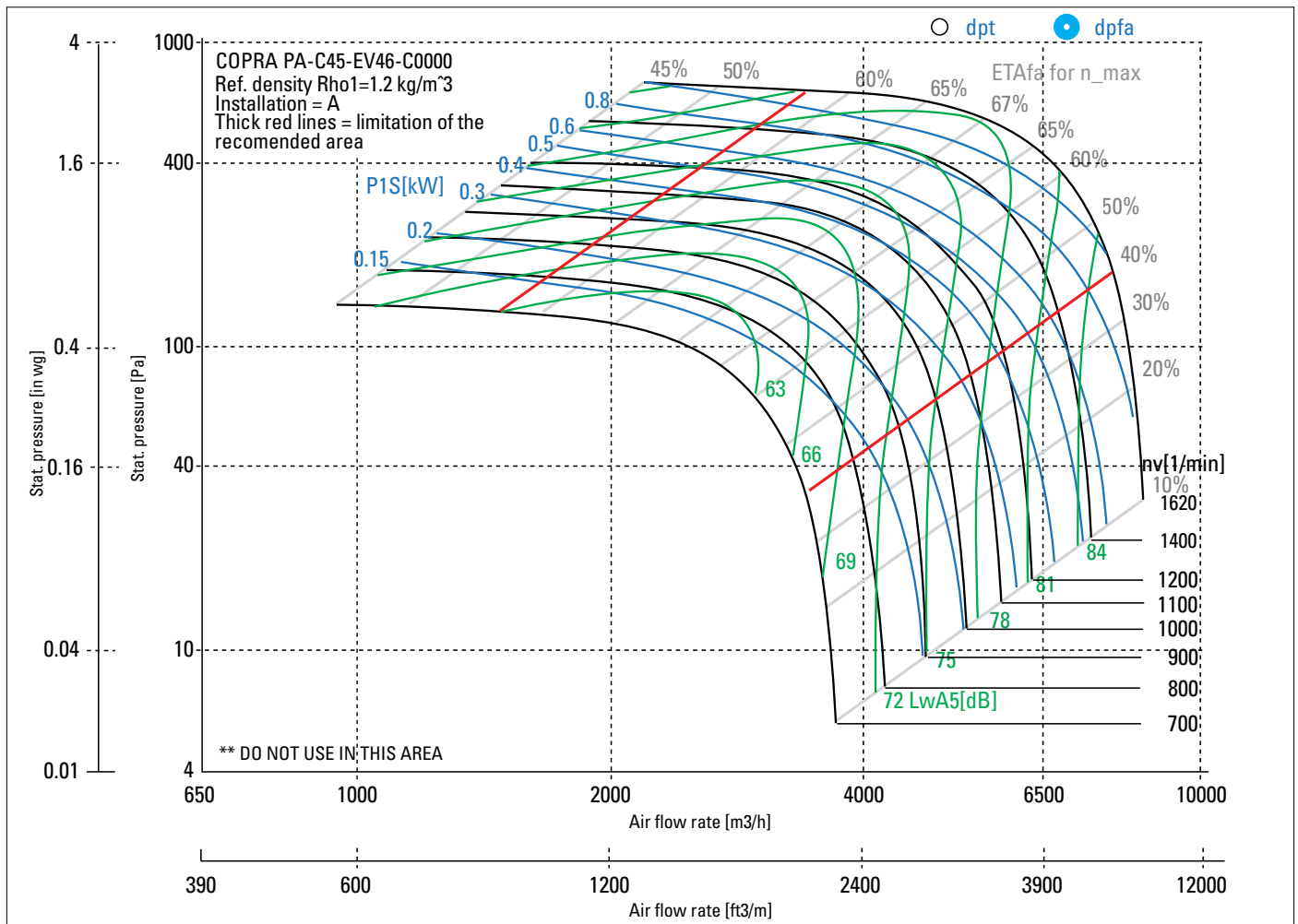

Technical Data according to ErP-REGULATION 327/2011/EU

measurement- / efficiency category A / static
 design status of VSD is integrated
 overall efficiency (ETA_{opt}) 72,3 %
 achieved efficiency grade (N_{ist}) 82,0
 required efficiency grade in 2015 (N) 62
 Year of manufacture is shown on the relevant rating plate for the product
 Manufacturer Nicotra Gebhardt GmbH, Gebhardtstr. 19-25, 74638 Waldenburg
 Type Model number PA-C45-EV46-C0000
 Air flow rate (V_{opt}) 5551 m³/h

pressure rise (dp_{opt}) 552 Pa
 Fan speed (n_{vopt}) 1620 min⁻¹
 motor power input (P_{1opt}) 1,18 kW
 specific ratio (d_{dopt}) 1,006
 Disposal/Recycling: Information on recycling and disposal is provided in the operating instruction.
 Information on maintenance: Information on installation, operation and maintenance is provided in the operating instructions.
 Additional components: The measurements do not use components which are not part of the fan.

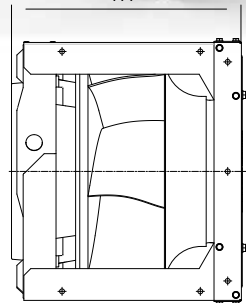
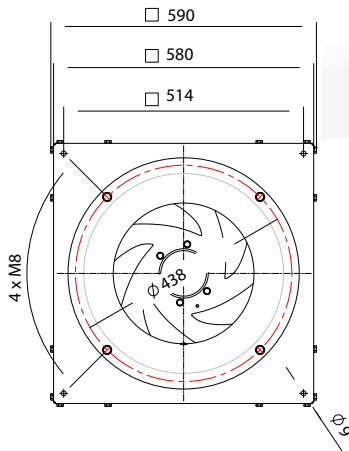

Description

Installation acc. DIN 24163 Part 1
 Reference density (Rho1)
 Medium temperature (t)
 Fan weight (m) basic device without accessories

Value	Dim.
A	
1,20	kg/m ³
20	C
33	kg

Feed data

Main's frequency (f_N)
 Voltage (U_N)

50/60	Hz
3~ 380-480	V

operational limits

Max. fan speed (n _{vmax})	1620	1/min
Max. absorbed power of the system (P _{maxS})	1,30	kW
max. current: Inverter out resp. control unit in (I _{max})	2,0	A
Temperature range for conveying medium (t _{min} ... t _{max})	-20...40	C

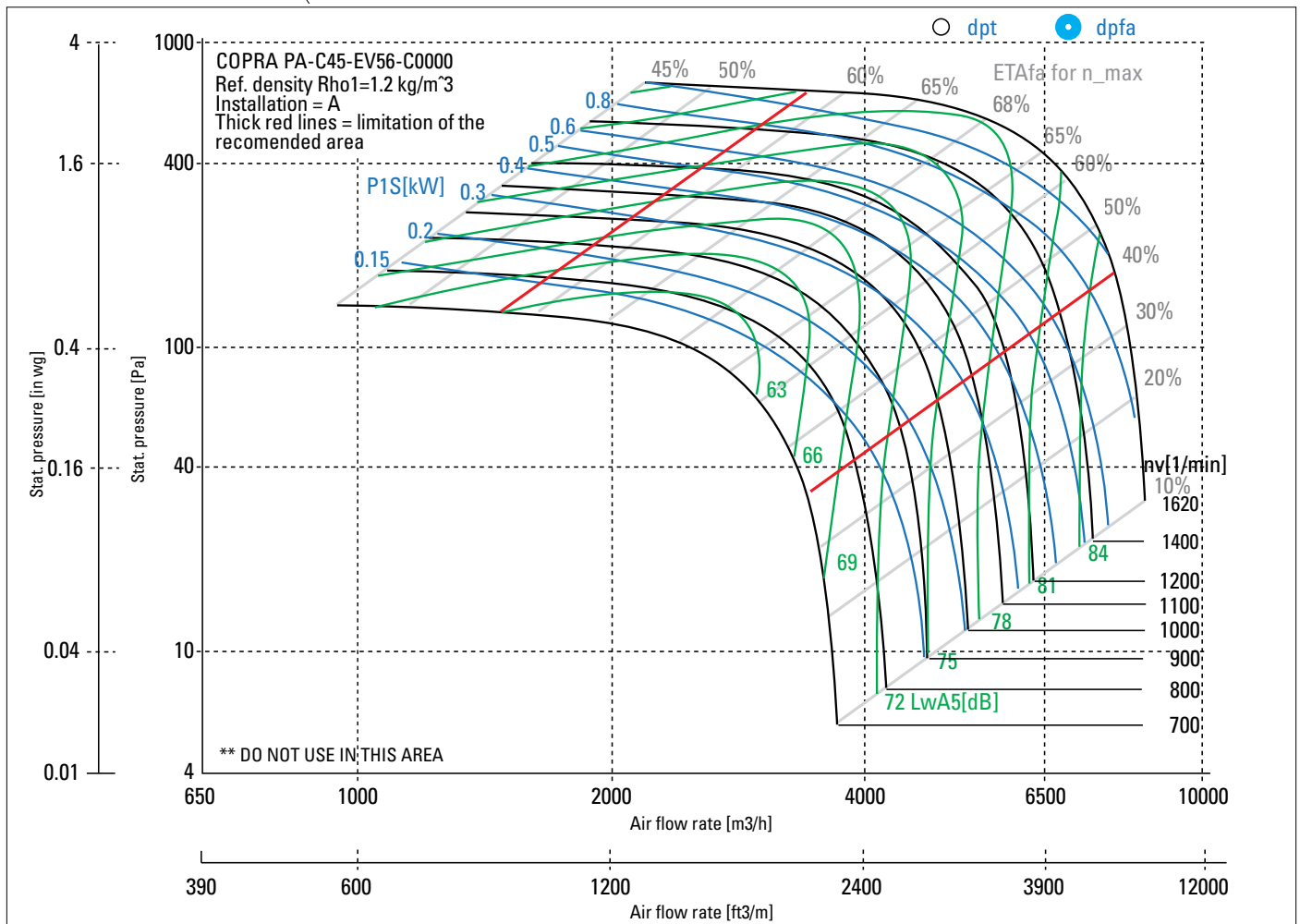

Technical Data according to ErP-REGULATION 327/2011/EU

measurement- / efficiency category A / static
 design status of VSD is integrated
 overall efficiency (ETA_{opt}) 73,0 %
 achieved efficiency grade (N_{ist}) 82,8
 required efficiency grade in 2015 (N) 62
 Year of manufacture is shown on the relevant rating plate for the product
 Manufacturer Nicotra Gebhardt GmbH, Gebhardtstr. 19-25, 74638 Waldenburg
 Type Model number PA-C45-EV56-C0000
 Air flow rate (V_{opt}) 5551 m³/h

pressure rise (dp_{opt}) 552 Pa
 Fan speed (n_{vopt}) 1620 min⁻¹
 motor power input (P_{1opt}) 1,17 kW
 specific ratio (d_{dopt}) 1,006
 Disposal/Recycling: Information on recycling and disposal is provided in the operating instruction.
 Information on maintenance: Information on installation, operation and maintenance is provided in the operating instructions.
 Additional components: The measurements do not use components which are not part of the fan.

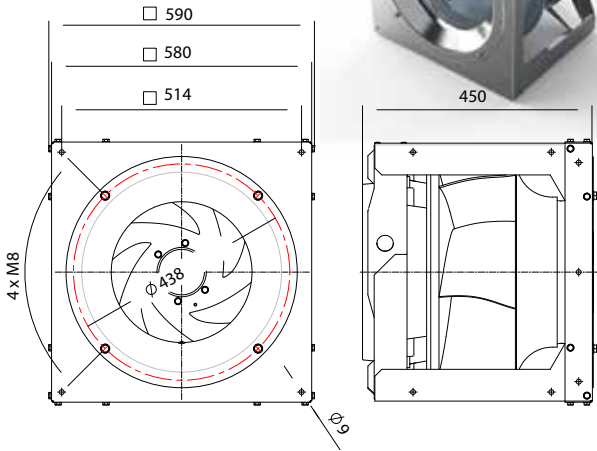

Description

Installation acc. DIN 24163 Part 1
 Reference density (Rho1)
 Medium temperature (t)
 Fan weight (m) basic device without accessories

Value	Dim.
A	
1,20	kg/m ³
20	C
41	kg

Feed data

Main's frequency (f_N)
 Voltage (U_N)

50/60	Hz
3~ 200-240	V

operational limits

Max. fan speed (n _{vmax})	2460	1/min
Max. absorbed power of the system (P _{maxS})	4,40	kW
max. current: Inverter out resp. control unit in (I _{max})	11,7	A
Temperature range for conveying medium (t _{min} ... t _{max})	-20...40	C

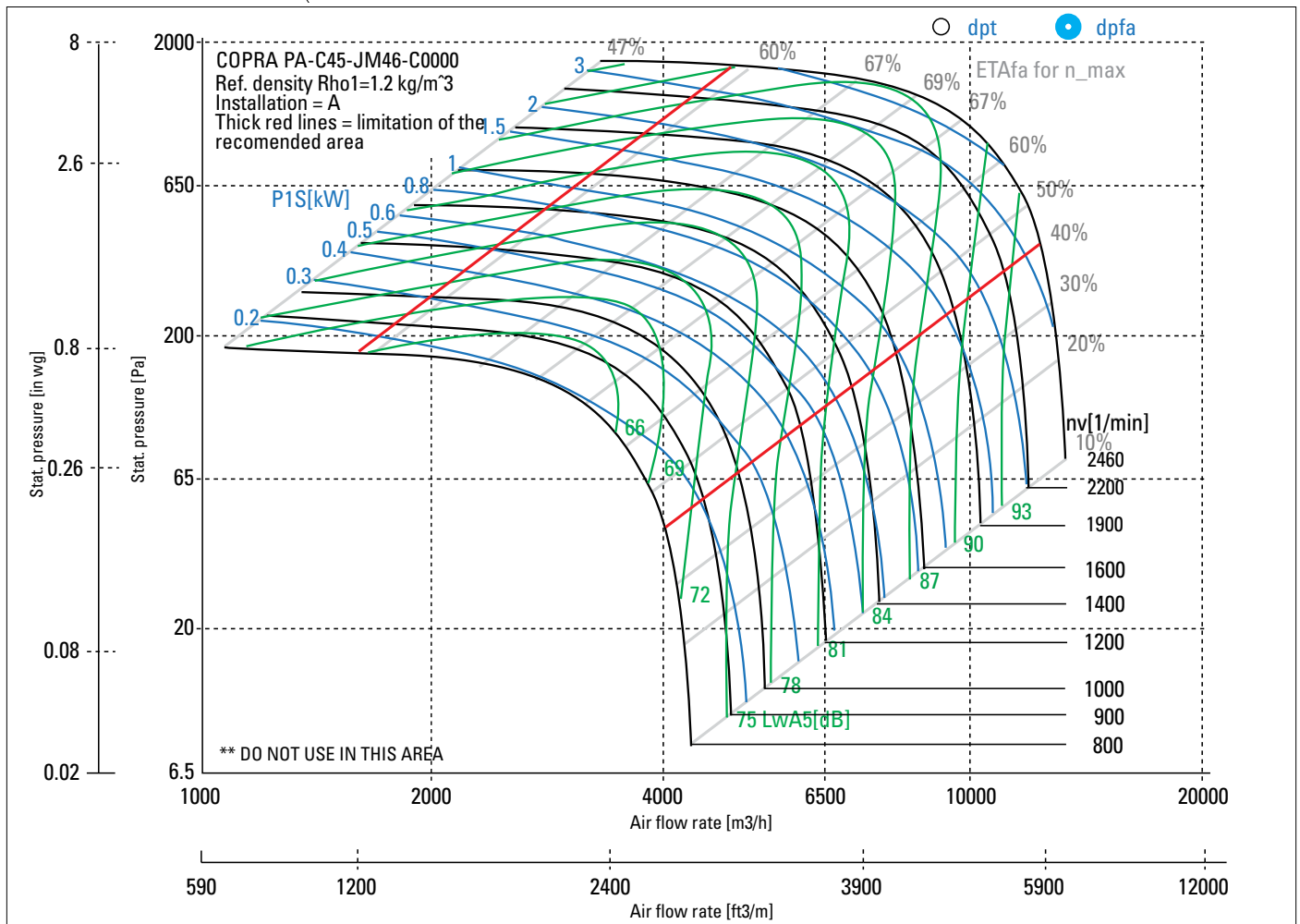

Technical Data according to ErP-REGULATION 327/2011/EU

measurement- / efficiency category A / static
 design status of VSD is integrated
 overall efficiency (ETA_{opt}) 71,6 %
 achieved efficiency grade (N_{ist}) 75,4
 required efficiency grade in 2015 (N) 62
 Year of manufacture is shown on the relevant rating plate for the product
 Manufacturer Nicotra Gebhardt GmbH, Gebhardtstr. 19-25, 74638 Waldenburg
 Type Model number PA-C45-JM46-C0000
 Air flow rate (V_{opt}) 8529 m³/h

pressure rise (dp_{opt}) 1317 Pa
 Fan speed (n_{opt}) 2460 min⁻¹
 motor power input (P_{1opt}) 4,36 kW
 specific ratio (d_{dopt}) 1,013
 Disposal/Recycling: Information on recycling and disposal is provided in the operating instruction.
 Information on maintenance: Information on installation, operation and maintenance is provided in the operating instructions.
 Additional components: The measurements do not use components which are not part of the fan.

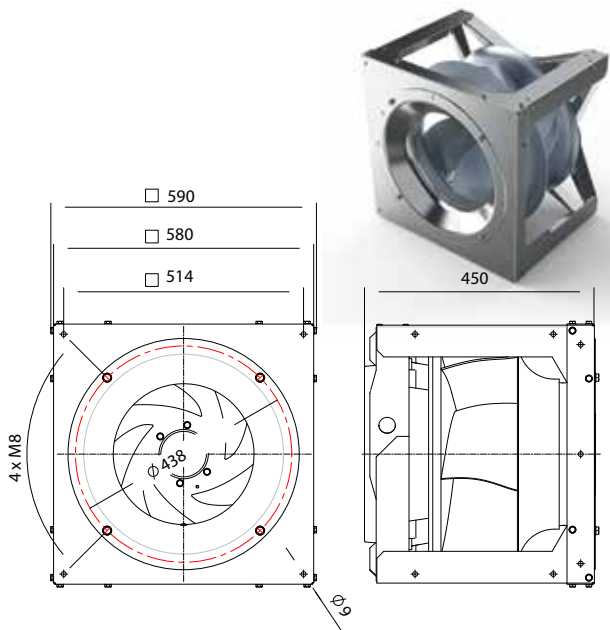

Description	Value	Dim.
Installation acc. DIN 24163 Part 1	A	
Reference density (Rho1)	1,20	kg/m ³
Medium temperature (t)	20	C
Fan weight (m) basic device without accessories	41	kg
Feed data		
Main's frequency (f _N)	50/60	Hz
Voltage (U _N)	3~ 380-480	V
operational limits		
Max. fan speed (n _{vmax})	2460	1/min
Max. absorbed power of the system (P _{maxS})	4,40	kW
max. current: Inverter out resp. control unit (I _{max})	6,7	A
Temperature range for conveying medium (t _{min} ... t _{max})	-20...40	C

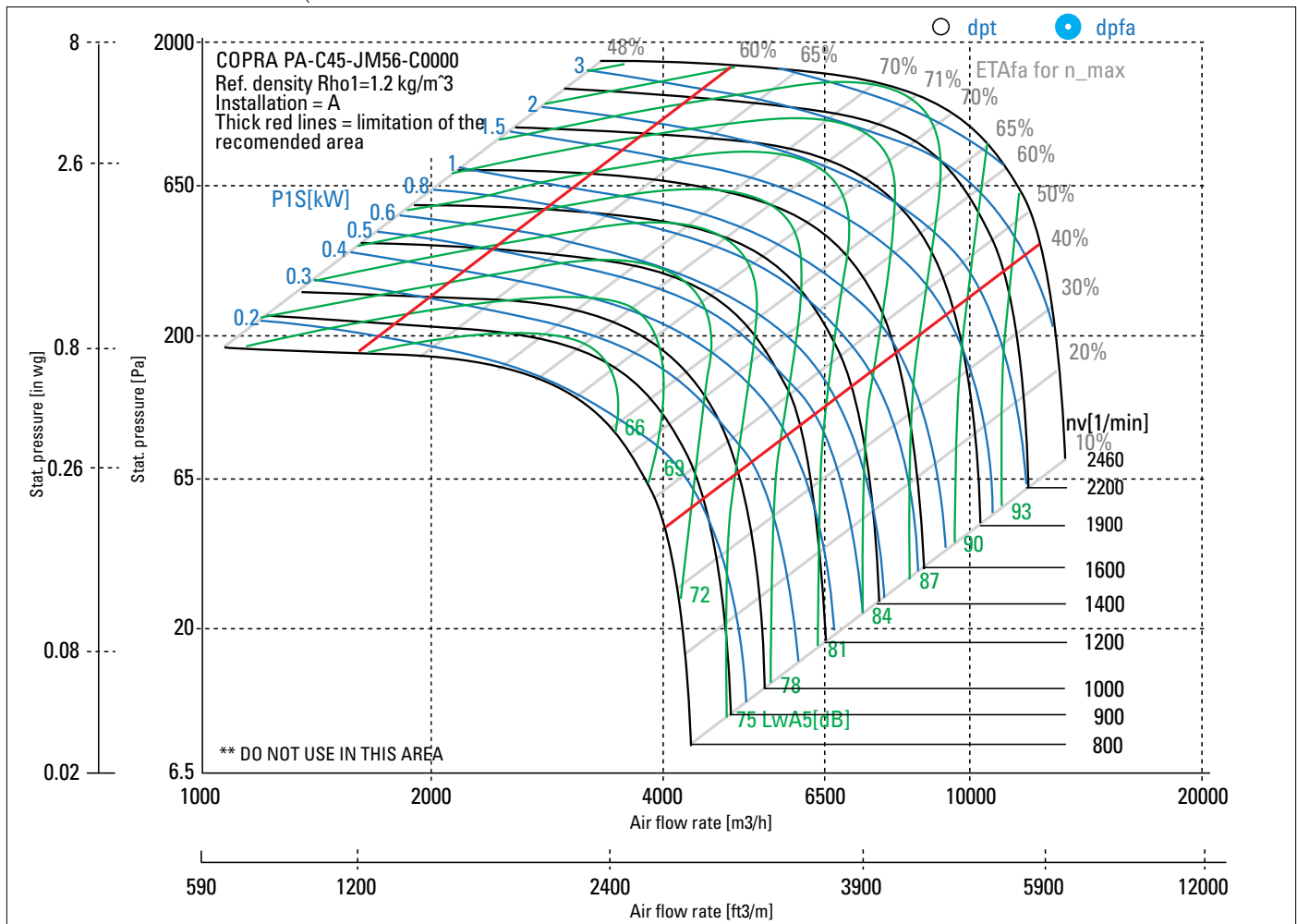

Technical Data according to ErP-REGULATION 327/2011/EU

measurement- / efficiency category A / static
 design status of VSD is integrated
 overall efficiency (ETA_{opt}) 73,7 %
 achieved efficiency grade (N_{ist}) 77,6
 required efficiency grade in 2015 (N) 62
 Year of manufacture is shown on the relevant rating plate for the product
 Manufacturer Nicotra Gebhardt GmbH, Gebhardtstr. 19-25, 74638 Waldenburg
 Type Model number PA-C45-JM56-C0000
 Air flow rate (V_{opt}) 8529 m3/h

pressure rise (dp_{opt}) 1317 Pa
 Fan speed (n_{vopt}) 2460 min⁻¹
 motor power input (P_{1opt}) 4,24 kW
 specific ratio (d_{dopt}) 1,013
 Disposal/Recycling: Information on recycling and disposal is provided in the operating instruction.
 Information on maintenance: Information on installation, operation and maintenance is provided in the operating instructions.
 Additional components: The measurements do not use components which are not part of the fan.

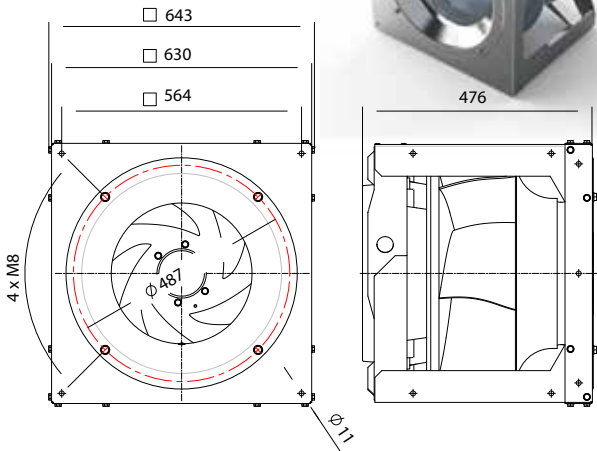

Description	Value	Dim.
Installation acc. DIN 24163 Part 1	A	
Reference density (Rho1)	1,20	kg/m ³
Medium temperature (t)	20	C
Fan weight (m) basic device without accessories	45	kg

Feed data	Value	Dim.
Main's frequency (f _N)	50/60	Hz
Voltage (U _N)	3~ 380-480	V

operational limits	Value	Dim.
Max. fan speed (n _{vmax})	2020	1/min
Max. absorbed power of the system (P _{maxS})	4,40	kW
max. current: Inverter out resp. control unit in (I _{max})	6,7	A
Temperature range for conveying medium (t _{min} ... t _{max})	-20...40	C

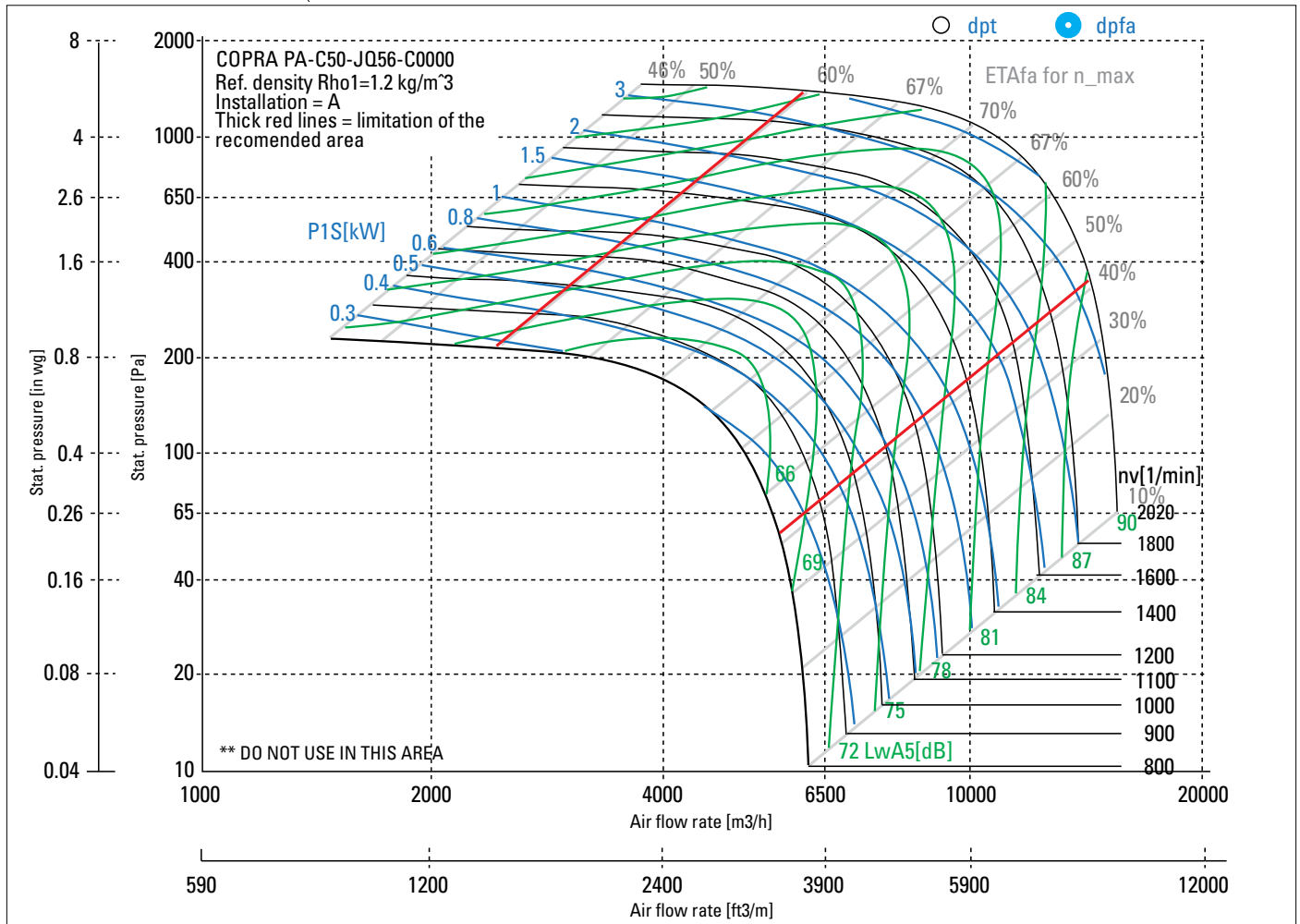

Technical Data according to ErP-REGULATION 327/2011/EU

measurement- / efficiency category A / static
 design status of VSD is integrated
 overall efficiency (ETA_{opt}) 73,1 %
 achieved efficiency grade (N_{ist}) 77,1
 required efficiency grade in 2015 (N) 62
 Year of manufacture is shown on the relevant rating plate for the product
 Manufacturer Nicotra Gebhardt GmbH, Gebhardtstr. 19-25, 74638 Waldenburg
 Type Model number PA-C50-JQ56-C0000
 Air flow rate (V_{opt}) 10056 m3/h

pressure rise (dp_{opt}) 1088 Pa
 Fan speed (n_{vopt}) 2020 min⁻¹
 motor power input (P_{1opt}) 4,16 kW
 specific ratio (d_{dopt}) 1,011
 Disposal/Recycling: Information on recycling and disposal is provided in the operating instruction.
 Information on maintenance: Information on installation, operation and maintenance is provided in the operating instructions.
 Additional components: The measurements do not use components which are not part of the fan.

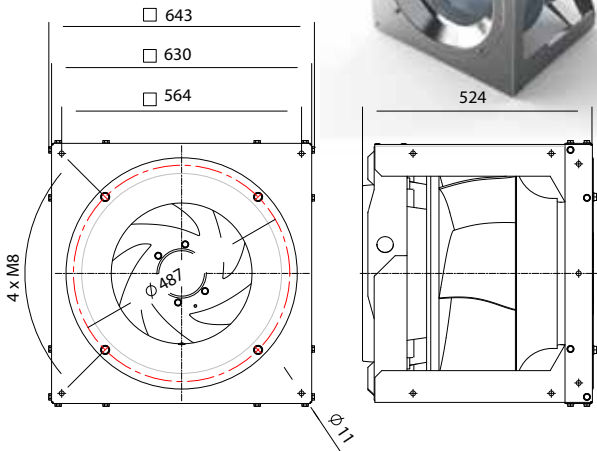

Description

Installation acc. DIN 24163 Part 1
 Reference density (Rho1)
 Medium temperature (t)
 Fan weight (m) basic device without accessories

Value	Dim.
A	
1,20	kg/m ³
20	C
60	kg

Feed data

Main's frequency (f_N)
 Voltage (U_N)

50/60	Hz
3~ 380-480	V

operational limits

Max. fan speed (n _{vmax})	2450	1/min
Max. absorbed power of the system (P _{maxS})	7,80	kW
max. current: Inverter out resp. control unit (I _{max})	11,8	A
Temperature range for conveying medium (t _{min} ... t _{max})	-20...40	C

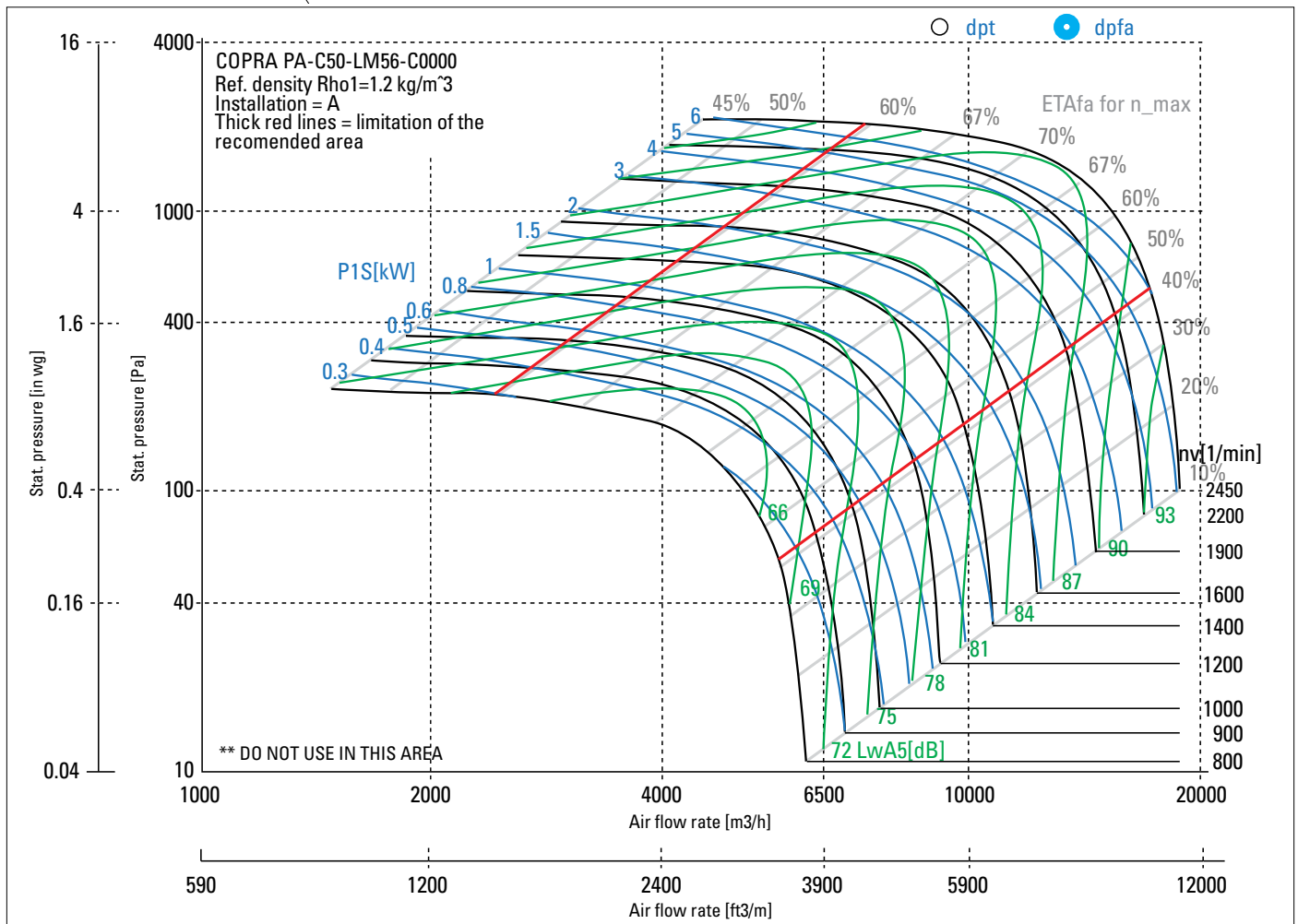

Technical Data according to ErP-REGULATION 327/2011/EU

measurement- / efficiency category A / static
 design status of VSD is integrated
 overall efficiency (ETA_{opt}) 72,8 %
 achieved efficiency grade (N_{ist}) 74,1
 required efficiency grade in 2015 (N) 62
 Year of manufacture is shown on the relevant rating plate for the product
 Manufacturer Nicotra Gebhardt GmbH, Gebhardtstr. 19-25, 74638 Waldenburg
 Type Model number PA-C50-LM56-C0000
 Air flow rate (V_{opt}) 12015 m3/h

pressure rise (dp_{opt}) 1620 Pa
 Fan speed (n_{opt}) 2450 min⁻¹
 motor power input (P_{1opt}) 7,43 kW
 specific ratio (d_{dopt}) 1,016

Disposal/Recycling: Information on recycling and disposal is provided in the operating instruction.

Information on maintenance: Information on installation, operation and maintenance is provided in the operating instructions.

Additional components: The measurements do not use components which are not part of the fan.

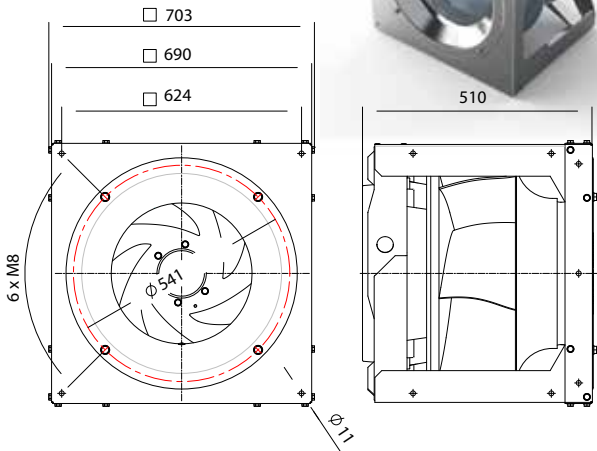

Description

Installation acc. DIN 24163 Part 1
 Reference density (Rho1)
 Medium temperature (t)
 Fan weight (m) basic device without accessories

Value	Dim.
A	
1,20	kg/m ³
20	C
59	kg

Feed data

Main's frequency (f_N)
 Voltage (U_N)

50/60	Hz
3~ 380-480	V

operational limits

Max. fan speed (n_{vmax})
 Max. absorbed power of the system (P_{maxS})
 max. current: Inverter out resp. control unit in (I_{max})
 Temperature range for conveying medium (t_{min} ... t_{max})

1670	1/min
4,40	kW
6,6	A
-20...40	C

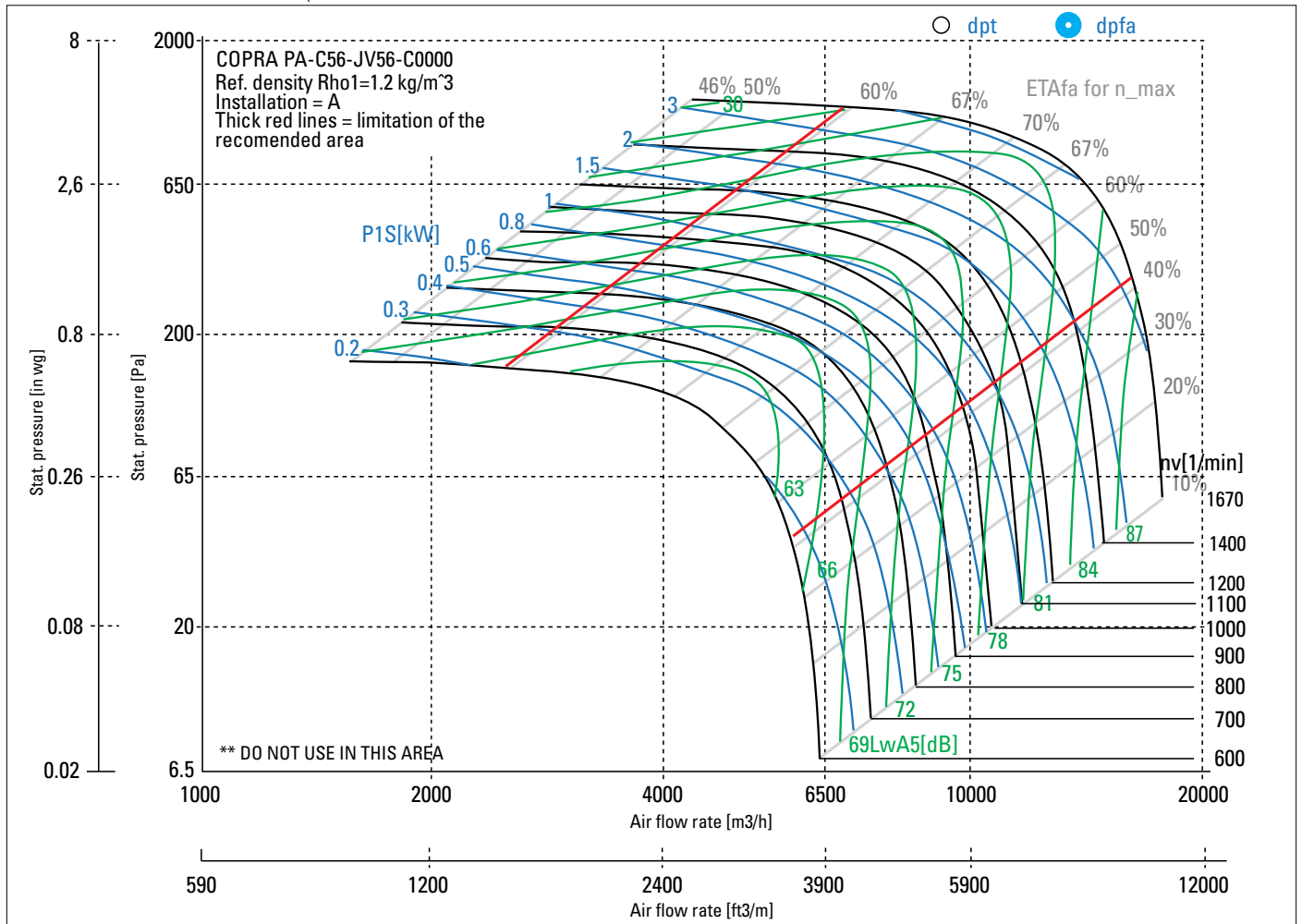

Technical Data according to ErP-REGULATION 327/2011/EU

measurement- / efficiency category A / static
 design status of VSD is integrated
 overall efficiency (ETA_{opt}) 73,0 %
 achieved efficiency grade (N_{ist}) 77,1
 required efficiency grade in 2015 (N) 62
 Year of manufacture is shown on the relevant rating plate for the product
 Manufacturer Nicotra Gebhardt GmbH, Gebhardtstr. 19-25, 74638 Waldenburg
 Type Model number PA-C56-JV56-C0000
 Air flow rate (V_{opt}) 11462 m³/h

pressure rise (dp_{opt}) 946 Pa
 Fan speed (n_{vopt}) 1670 min⁻¹
 motor power input (P_{1opt}) 4,13 kW
 specific ratio (d_{dopt}) 1,009
 Disposal/Recycling: Information on recycling and disposal is provided in the operating instruction.
 Information on maintenance: Information on installation, operation and maintenance is provided in the operating instructions.
 Additional components: The measurements do not use components which are not part of the fan.

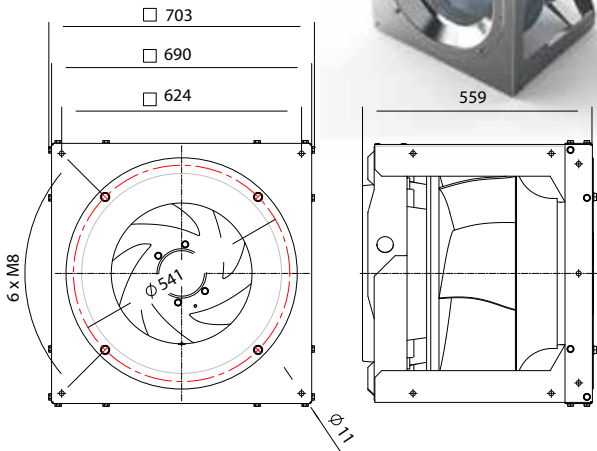

Description

Installation acc. DIN 24163 Part 1
 Reference density (Rho1)
 Medium temperature (t)
 Fan weight (m) basic device without accessories

Value	Dim.
A	
1,20	kg/m ³
20	C
73	kg

Feed data

Main's frequency (f_N)
 Voltage (U_N)

50/60	Hz
3~ 380-480	V

operational limits

Max. fan speed (n_{vmax})
 Max. absorbed power of the system (P_{maxS})
 max. current: Inverter out resp. control unit in (I_{max})
 Temperature range for conveying medium (t_{min} ... t_{max})

2030	1/min
7,80	kW
12,0	A
-20...40	C

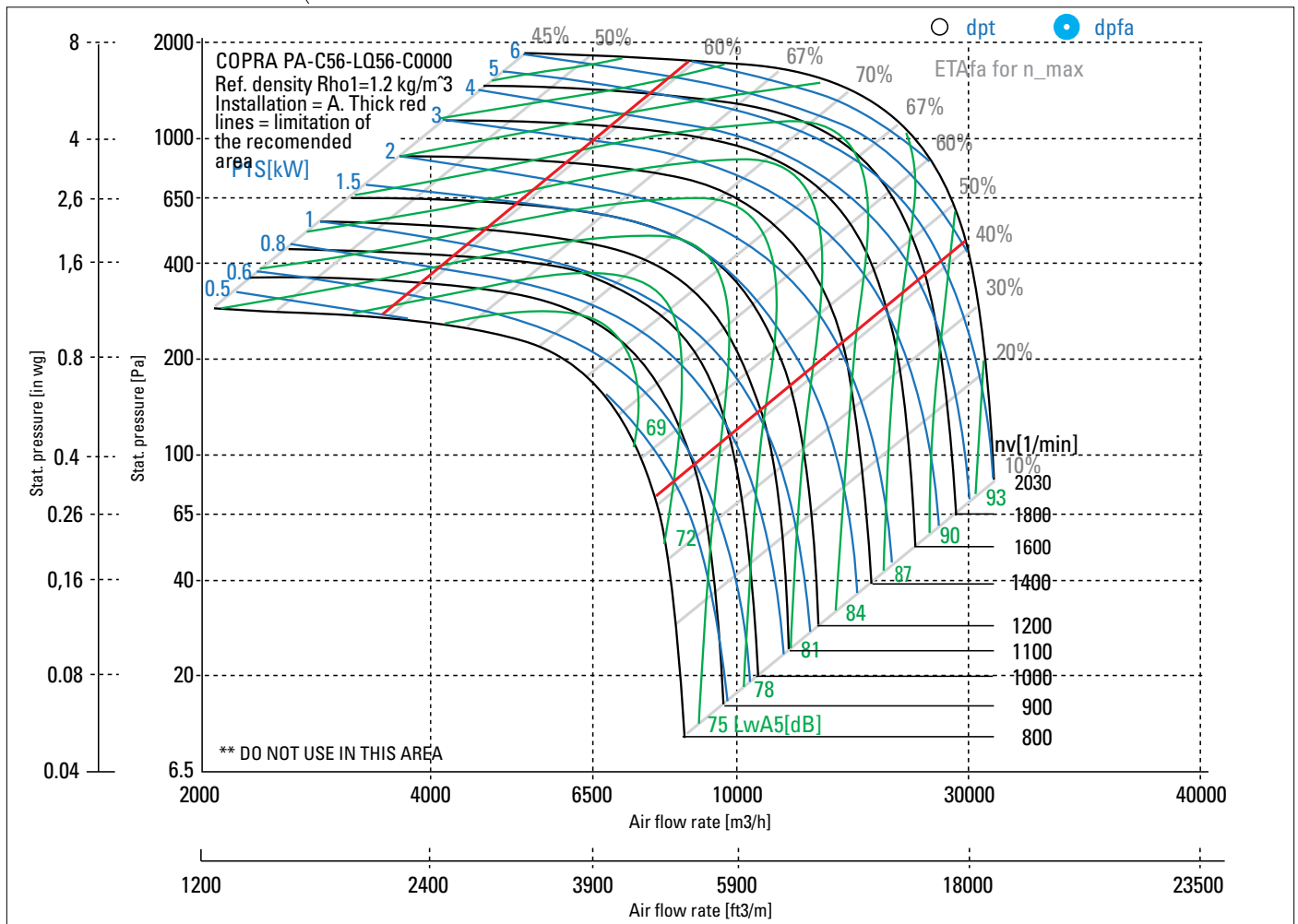

Technical Data according to ErP-REGULATION 327/2011/EU

measurement- / efficiency category A / static
 design status of VSD is integrated
 overall efficiency (ETA_{opt}) 72,7 %
 achieved efficiency grade (N_{ist}) 74,0
 required efficiency grade in 2015 (N) 62
 Year of manufacture is shown on the relevant rating plate for the product
 Manufacturer Nicotra Gebhardt GmbH, Gebhardtstr. 19-25, 74638 Waldenburg
 Type Model number PA-C56-LQ56-C0000
 Air flow rate (V_{opt}) 13986 m3/h

pressure rise (dp_{opt}) 1406 Pa
 Fan speed (n_{opt}) 2030 min⁻¹
 motor power input (P_{1opt}) 7,51 kW
 specific ratio (d_{dopt}) 1,014
 Disposal/Recycling: Information on recycling and disposal is provided in the operating instruction.
 Information on maintenance: Information on installation, operation and maintenance is provided in the operating instructions.
 Additional components: The measurements do not use components which are not part of the fan.



We will find the best individually tailored solution for you.

Our product experts will work with you to configure the right solution for your facility, whatever the application, size or requirements. Ensuring your system maximizes energy savings while conforming to ever-changing efficiency standards is our goal. Reach out for detailed, individual advice today.

NICOTRA | **Gebhardt**[®]

Nicotra Gebhardt Germany

Nicotra Gebhardt GmbH

Gebhardtstraße 19-25

74638 Waldenburg (Germany)

Phone +49 7942 1010

Fax +49 7942 101 170

E-Mail info.ng.de@RegalRexnord.com

Web www.nicotra-gebhardt.com

Nicotra Gebhardt Italy

Regal Beloit Italy S.p.A.

Via Modena, 18

24040 Zingonia (BG) (Italy)

Phone +39 035 873 111

Fax +39 035 884 319

E-Mail info.ng.it@RegalRexnord.com

Web www.nicotra-gebhardt.com

The proper selection and application of products and components, including assuring that the product is safe for its intended use, are the responsibility of the customer. To view our Application Considerations, please visit <https://www.regalrexnord.com/Application-Considerations>.

To view our Standard Terms and Conditions of Sale, please visit <https://www.regalrexnord.com/Terms-and-Conditions-of-Sale> (which may redirect to other website locations based on product family).

"Regal Rexnord" is not indicative of legal entity. Refer to product purchase documentation for the applicable legal entity.

Regal Rexnord, Nicotra Gebhardt, VGreen EVO, and COPRA are trademarks of Regal Rexnord Corporation or one of its affiliated companies.

© 2022 Regal Rexnord Corporation, All Rights Reserved.
MCB22101E • Form# 10526E

RegalRexnord[™]