



General Pump recommends using a safety relief device in conjunction with this unloader valve when installed on a positive displacement pump. General Pump is not liable and assumes no responsibility when used in a customer's high pressure system.

FEATURES

- Sturdy brass and steel construction
- Multiple connections for easy installation
- Powerful spring action provides reliable pressure adjustment
- Hexagonal shaped check valve avoids jamming
- Knob is fitted with a locknut for minimum and maximum pressure regulation

SPECIFICATIONS

Part Number	PULSAR3KHP
Max. Volume.....	7.8 GPM ¹
Max. Discharge Pressure.....	4000 PSI
Max Temperature.....	194 ⁰ F ²
Port Sizes: Inlet.....	3/8" NPT-F
Outlet.....	3/8" NPT-F
Bypass.....	3/8" NPT-F
Overall Dimensions.....	7.0" x 3.2" x 2.3"
Weight	1.6 lbs.
Materials	Brass, Stainless Steel, Buna-N

¹ Maximum flow rate: 4.0 GPM if fed through the lower connection.
² This unloader has been designed to operate at a continuous water temperature of 86°F. It can be operated for short periods at a maximum temperature of 194°F.

DIMENSIONS

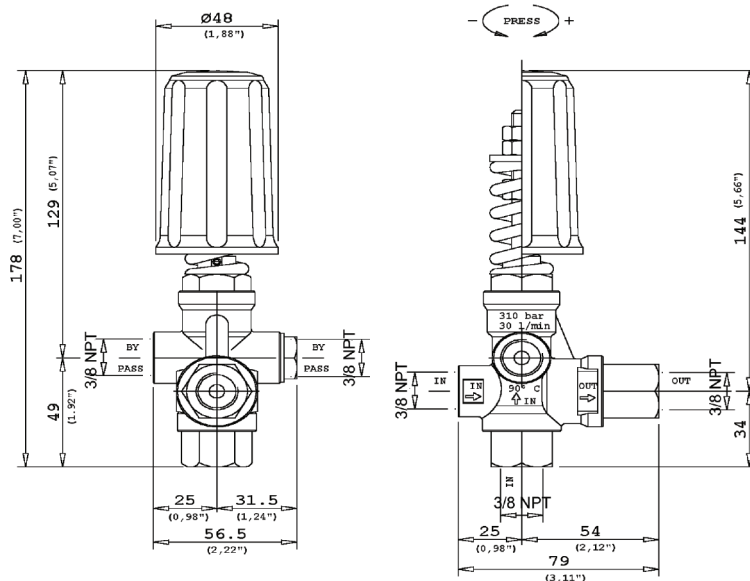

INSTRUCTIONS

SELECTION

This product is to be used with clean water which can contain the addition of normal detergents. For use involving different or corrosive liquids, contact the General Pump Customer Service Department. Appropriate filtration should be installed when using water that may contain any sort of debris. Choose the valve appropriate for the system rated pressure, maximum flow rate and maximum temperature. In any case, the pressure of the machine should not exceed the permissible pressure rate imprinted on the valve. The supply of the lower connection is possible with reduced flow rate (see point 1).

INSTALLATION

This unloader, on a system that produces hot water must be fitted in **front of the heat generator**. This unloader is meant to be incorporated on a finished machine. On a system that generates hot water, anticipate the fitting of accessories that limit the accidental increase of fluid temperature.

Always install a safety valve that protects the pressurized inlet channel.

Choose the correct nozzle size that is able to discharge regularly, on bypass, at least 5% of the total flow of the system, in order to achieve a constant pressure, and avoid troublesome pressure spikes.

When the nozzle wears, the pressure drops. After installing a new nozzle, re-adjust the system to the original pressure setting.

OPERATIONS

The valve regulates the maximum pressure of the system through a piston, which acts on a ball correctly positioned, that closes the bypass opening. A check valve cuts out the delivery section, the pressure of which controls the drive of the piston. Each setting operation should be made when the system is operational and the nozzle open.

ATTENTION: The nuts (item 22 - 2 pieces) must never be removed. Removal will compromise a mechanical safety feature that limits the maximum pressure, thus could result in serious damage to people and equipment.

MAINTENANCE

Maintenance should be carried out by specialized technicians.

Standard: every 400 working hours (10,000 cycles), control and lubricate the seals with water resistant grease.

Special: every 800 working hours (20,000 cycles), control the wear of the seals and internal parts and, if necessary, replace with original General Pump parts taking care during installation to lubricate with water resistant grease.

ATTENTION: reassemble the valve in the correct sequence paying special attention to the nuts (item 22) by fastening them with a drop of strong glue.

The manufacturer is not responsible for damage as a result from incorrect fitting and maintenance.

TROUBLESHOOTING

PROBLEMS	PROBABLE CAUSES	SOLUTIONS
Frequenyt unloader cycles	Damaged check valve o-ring Leaking connections Restricted bypass	Replace Check and replace Clean or adapt
Unloader does not come up to pressure	Unloader not properly sized Debris lodged in unloader Unloader piston o-ring worn Worn nozzle	Change spring or type of valve Clean unloader Replace Replace
Excessive pressure spikes	There is not a minimum of 5% flow in bypass Excessive flow in bypass Spring totally compressed	Reset Change type of valve or adjust passages Loosen knob and change nozzle
Unloader won't go into bypass	Discharge check valve jammed Worn discharge check valve o-ring Debris in unloader valve	Clean or replace Replace Clean unloader

PARTS LIST

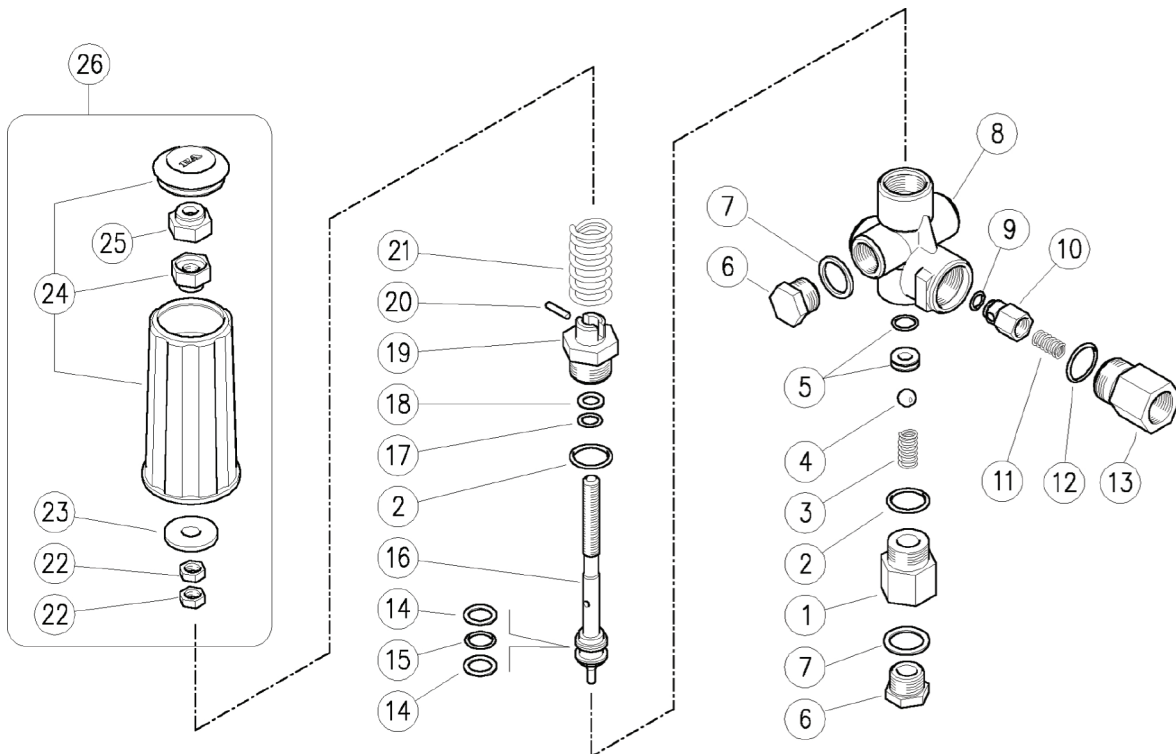

ITEM	PART #	DESCRIPTION	QTY
1	Y60005031	Inlet Fitting, 3/8 NPT-Brass	1
2*	Y10306801	O-ring, 1.78x17.7 mm	2
3	Y60001551	Spring, 1.4 x 10 x 16 mm	1
4*	Y14746100	SS Ball, 13/32"	1
5*	Y60025920	Seat, 8mm & O-ring	1
6	Y60002531	Grub Screw, Brass, 3/8 NPT-M	2
7	Y14404200	Washer, 17.7 x 22 x 1.5 mm	2
8	Y60007535	Brass Housing	1
9*	Y10321308	O-ring, 3 x 6 mm	1
10	Y60005231	Shutter Pin, Brass	1
11	Y60005351	Spring, 0.7 x 9 x 20 mm, SS	1
12*	Y10307002	O-ring, 1.78 x 18.77 mm	1
13	Y60005931	Outlet Fitting, 3/3 NPT-F, Brass	1
14*	Y10402100	Back-up Ring, open, 11.5 x 15.9 x 1.2 mm	2

ITEM	PART #	DESCRIPTION	QTY
15*	Y10317508	O-ring, 2.62 x 10.77 mm	1
16	Y60006123	Valve Piston, SS	1
17*	Y10317008	O-ring, 2.62 x 7.7 mm	1
18*	Y10402000	Back-up Ring, 8 x 12.6 x 1.2 mm	1
19	Y60006431	Piston Holder, Brass	1
20	Y15102100	Roll Pin, 3 x 14 mm, SS	1
21	Y60003361	Spring, 5.7 x 26 x 53 mm	1
22	Y11457331	Hex Nut, M8, Brass	2
23	Y14372040	Washer, 9.2 x 24 x 0.5 mm	1
24	Y60000424	Knob & Plug	1
25	Y11458910	Hex Locknut, M8	1
26	YUKNOB	Knob Kit	1

* YKITPULSAR3KHP Repair Kit