

MAHLE



MAHLE — practical tips

Replacing the A/C compressor
and flushing the A/C system

BEHR[®]

Replacing the A/C compressor

Overview and important information

General

The air conditioning compressor is usually driven by the vehicle engine via a V-ribbed belt. It compresses or circulates the refrigerant in the system. There are different types of air conditioning compressor.

Principle of operation

At low pressure and low temperature, the gaseous refrigerant coming from the evaporator is sucked in, compressed, and then directed to the condenser, still in its gaseous state, under high pressure and at a high temperature.

Impact in the event of failure

The following signs may indicate a damaged or broken air conditioning compressor:

- Leaks
- Noise
- Insufficient cooling or absence of cooling
- Error code in the climate control unit or engine/central control unit

Malfunctions may be due to a variety of reasons:

- Bearing damage due to defective clamping device or wear and tear
- Leaks in the air conditioning compressor shaft or housing
- Mechanical damage to the air conditioning compressor housing
- Bonding (electrical connections)
- Electric control valve
- Insufficient refrigerant oil
- Insufficient refrigerant
- Solid matter (e.g., chips)
- Moisture (corrosion, etc.)
- Defective clamping elements, engine accessories

Troubleshooting

Function test and pressure measurement for the installation:

- Does the air conditioning compressor switch on, is the plug firmly connected, is a voltage applied?
- Check electric control valve or actuation
- Check the drive belts for positioning, damage, and tension
- Carry out visual inspection for leaks
- Check that the refrigerant lines are properly secured
- Compare pressure on the high- and low-pressure sides
- Read out fault memory

A/C compressor cross section

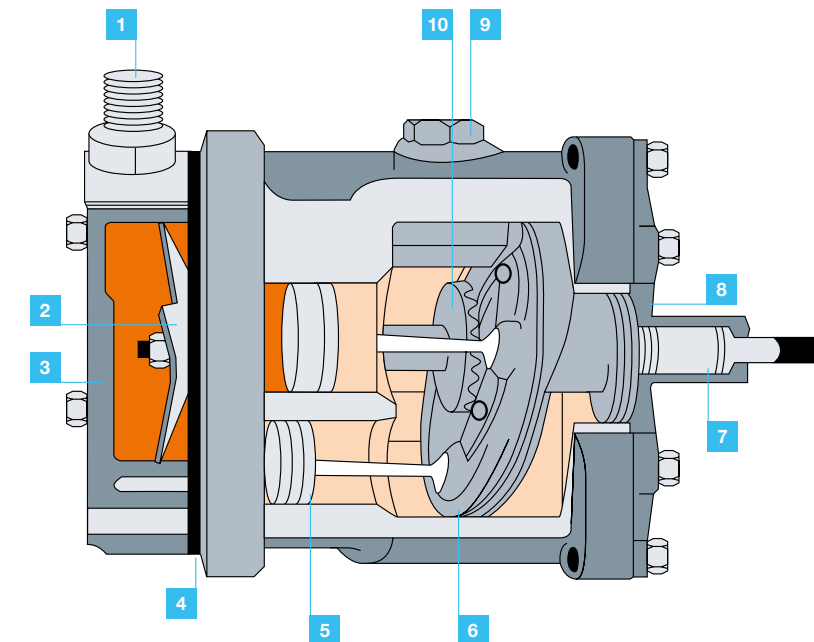

- | | | | |
|---|------------------------|----|---------------|
| 1 | Screw connections | 6 | Swash plate |
| 2 | Suction pressure valve | 7 | Driving shaft |
| 3 | Cylinder head | 8 | Housing |
| 4 | Gasket | 9 | Oil cap |
| 5 | Piston | 10 | Gear wheel |



Caution

Before installing a new A/C compressor, always check the oil quantity and viscosity in accordance with the manufacturer specifications and top up if necessary! (See work process on the next page.)

Is the A/C compressor faulty?

Work process for failure analysis and replacement

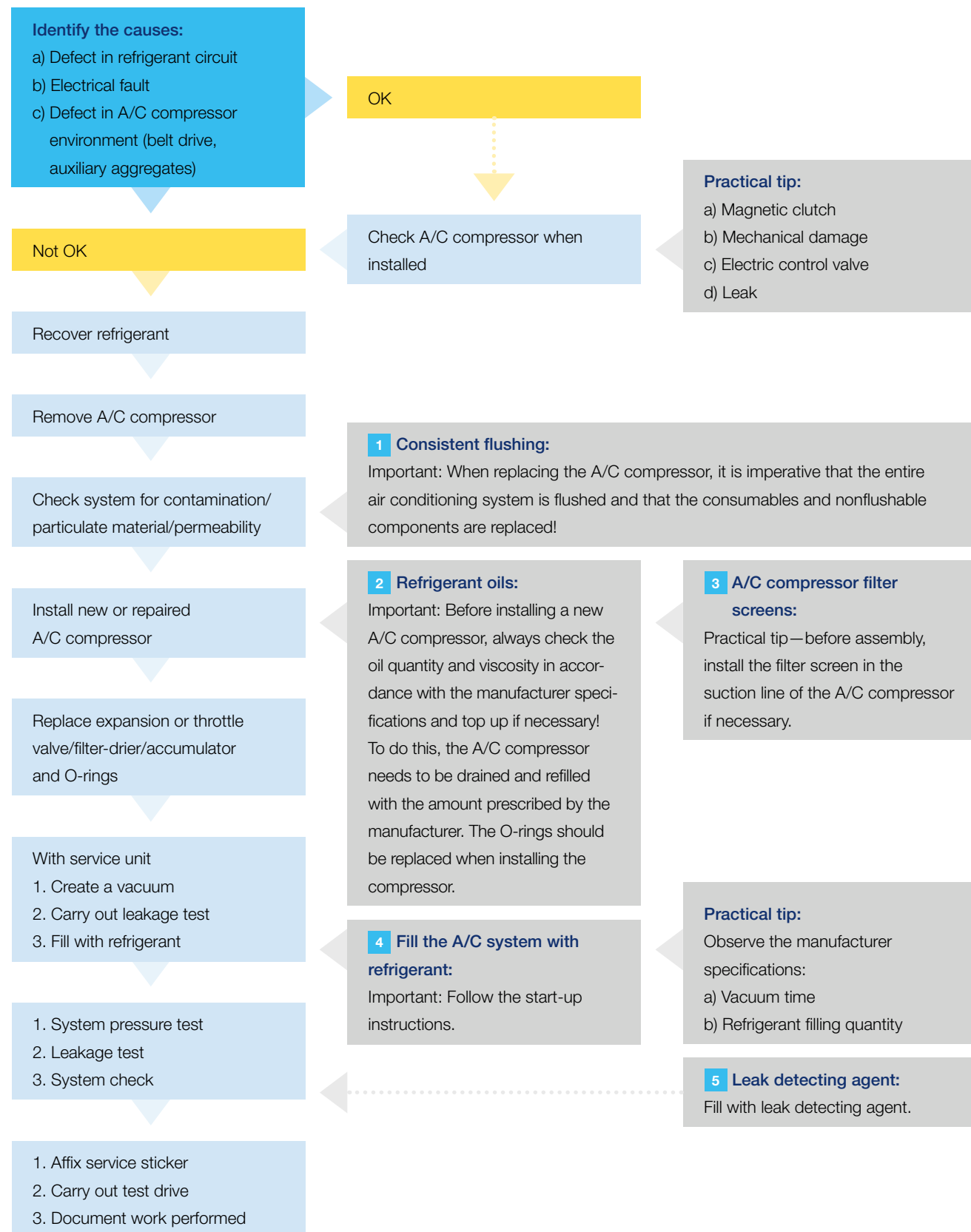

1 Consistent flushing

Dirt particles in the air conditioning circuit can only be removed with thorough flushing of the entire system. Depending on the contamination level, it is advisable to use refrigerant R134a or R1234yf, or a special flushing solution. Air conditioning compressors, driers (accumulators), and expansion or throttle valves cannot be flushed. Because system contamination (abrasion particles, chips) is always assumed, or cannot be ruled out, when the air conditioning compressor is defective, the system must always be flushed when replacing these components.

2 Refrigerant oils

Note the manufacturer specifications and accompanying leaflet/viscosity.

2.1 Breakdown of oil quantities

Refrigerant oil is found in every component in the air conditioning system. In the event of a repair, the oil is removed along with the component being replaced. It is therefore imperative that the system is topped up again with the relevant quantity of oil. The chart below illustrates the average breakdown of the oil quantities within the system.

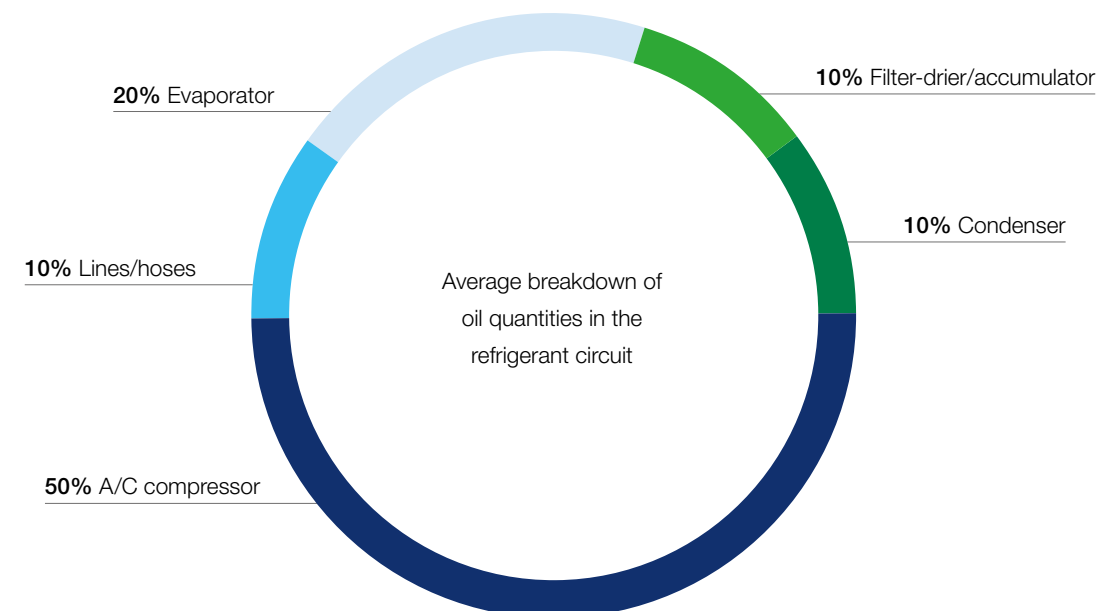

2.2 Note the oil quantity and specification

Before installing a new air conditioning compressor or topping up the system with refrigerant oil, the oil quantity and viscosity must always be checked in accordance with the vehicle manufacturer specifications.

2.3 System oil quantity in the air conditioning compressor

As one air conditioning compressor may be used for different vehicles or systems, it is crucial to check or adjust the oil filling quantity before installing the compressor. All the oil must be drained and collected for this purpose. The compressor must then be refilled with the total oil quantity specified by the vehicle manufacturer (system oil quantity). To ensure that the oil is distributed evenly, the compressor must be turned ten times by hand before installation. This also corresponds to the instructions issued by the air conditioning compressor manufacturer Sanden. Individual vehicle manufacturer specifications must be taken into account in each case.

3 A/C compressor filter screens

In principle, every air conditioning system must be flushed when replacing the air conditioning compressor in order to remove contamination and foreign material from the system. If contamination remains in the circuit after flushing, the use of filter screens in the suction line can help to prevent damage.

4 Filling the A/C system with refrigerant

Start-up instructions for the air conditioning compressor:

- The refrigerant must always be filled via the air conditioning service unit using the service connection on the high-pressure side, to prevent refrigerant hammering in the air conditioning compressor.
- Only the appropriate refrigerant should be used, in the quantity/specification prescribed by the vehicle manufacturer.
- Set the air distribution to the “center nozzles” position and open all center nozzles.
- Set the switch for the fresh air blowers to the central position.
- Set the temperature to maximum cooling.
- Start the engine (without running the air conditioning system) and let the engine run uninterrupted at idle-running speed for at least 2 minutes.
- Switch on the air conditioning for about 10 seconds at idle-running speed; switch off the air conditioning for around 10 seconds. Repeat this process at least five times.
- Carry out a system check.

5 Leak detecting agent

Insufficient refrigerant can also cause damage to the air conditioning compressor. For this reason, regular air conditioning maintenance and, if necessary, addition of contrast agent (e.g., Warranty Line from BRAIN BEE®) to the system is recommended. There are various methods for doing this. The use of contrast agent in the vehicle should be documented. This prevents over-filling, which—in extreme cases—can cause damage to the air conditioning compressor.



Important!

Always replace all O-rings and coat them with refrigerant oil prior to installation. Before installing a new A/C compressor, always check the oil quantity and viscosity in accordance with the manufacturer specifications and top up if necessary! When replacing the A/C compressor, it is imperative that the entire air conditioning system is flushed and that the consumables and nonflushable components are replaced!



Flushing the A/C system — methods

Caution!

When replacing the A/C compressor, it is imperative that the entire air conditioning system is flushed and that the consumables and nonflushable components are replaced!

Flushing the air conditioning system is one of the most important activities performed during repair work or when an air conditioning compressor is damaged. The flushing process removes contamination and harmful substances from the air conditioning circuit.

Flushing is necessary to ensure proper repairs and avoid expensive follow-up work. In addition, it maintains the supplier's warranty and ensures customer satisfaction.

There are two flushing methods for flushing air conditioning systems:

- Flushing method A:
Flushing with refrigerant and service units
- Flushing method B:
Flushing with flushing agent (Step 1),
blowing out/drying with nitrogen (Step 2)

However, air conditioning compressors, expansion or throttle valves, and filter driers or accumulators cannot be flushed. During the flushing process, they must therefore be bypassed using adapters. After the flushing process is complete, the aforementioned valves and filters must be replaced.



Method A: flushing with refrigerant and service unit

As standard, all MAHLE ArcticPRO® air conditioning service units have an integrated flushing function that allows fast, low-cost flushing of the air conditioning system with the refrigerants R134a or

R1234yf. An external flushing unit and parts from a flushing kit will be required—both are available separately. After starting the function on the unit, the vehicle air conditioning system is flushed with liquid

refrigerant under high pressure and then evacuated. This cycle should be completed three times in order to achieve an optimal cleaning result.



Refrigerant
R134a

Part number: 1010350383XX

ArcticPRO® ACX 380 is the top A/C service unit in the equipment series for R134a. You can't get better than that! It offers all the distinguishing features of this line, in addition to the extreme convenience of the integrated POE oil circuit, which is a must for anyone who frequently services hybrid or electric cars in addition to vehicles with traditional engines. ACX 380 for R134a systems can be easily converted to R1234yf or, if required, the refrigerant R513a. Thanks to the optional integration of our diagnostic tool for A/C systems, an expert diagnosis of the air conditioning components can be carried out directly on the A/C service unit.



Refrigerant
R1234yf

Part number: 1010350384XX

ArcticPRO® ACX 480 is the flagship model in the equipment series for R1234yf. With the ACX 480, the complete A/C service can be entrusted fully to the unit's automated processes. This ensures an accurate result and allows you to take care of other tasks in the meantime. This guarantees a reliable, effective, and economical A/C service! The ACX480 also offers integration with highly innovative and practical management apps, as well as with the TechPRO® diagnostic tool, which expands the unit's capabilities even further.

With these advanced features, these two units offer an unprecedented level of flexibility and professionalism.

Accessories

For flushing with the A/C service unit ArcticPRO®

With the A/C service units, MAHLE is expanding its range for workshop connectivity: using a smartphone app, workshop technicians can view the workflows and unit status or automatically order a service. The ASA interface on the unit and the integration of the unit in the workshop network enable fast data exchange. The large touch screen, which is standard on all units, provides a continuous display of all information and programmed procedures, as well as the current status. A quick-start can be

initiated at any time. While automatic software updates are performed in the background via Wi-Fi, work can continue on the vehicle. Possible leaks in the air conditioning system are quickly detected with nitrogen or forming gas via a direct connection to the air conditioner. For a time-saving service, the devices can be serviced remotely: workshops can obtain fast support and diagnostics directly on the unit via Wi-Fi.

ACX universal flushing unit for refrigerants R134a and R1234yf

- Flushing tank with support for flexible usage—entirely independent of the A/C service unit location and model
- Ergonomically positioned: control sight glass to check flushing process and refrigerant purity
- Flexible application: HP hose connector adapter set for various A/C service units
- Flushing adapter set (3/8" and 1/4") allows connection to all standard flushing adapters for air conditioning systems or to a system's individual components
- Coupling adapter set for refrigerants R134a and R1234yf to connect the LP coupling to the flushing unit
- Optional: Protective storage cover



Part number: 1010350150XX

ArcticPRO® ROU—recovery only unit

- Removes unknown and contaminated refrigerants from vehicle air conditioning systems simply and safely.
- Environmentally friendly: professional and safe disposal protects people and the environment.
- Economical: the ROU is immediately ready to use together with an A/C service unit. No other materials and supplies are required.
- Efficient: our patented internal cycle guarantees a fast service with a 95% recovery rate within 30 minutes.



BRAIN BEE® Warranty Line flushing kit R134a



Part number 1010350053XX

BRAIN BEE® Warranty Line flushing kit R1234yf



Part number 1010350198XX

The flushing kits contain various adapters to bypass nonflushable components such as filter-driers and expansion valves, etc. The kits can be used with all our service units.

IDX 500 Refrigerant analysis unit

Internal analysis unit for the MAHLE ACX A/C service units for refrigerants R134a and R1234yf

- Faster than the predecessor model
- Clearly indicates whether R134a or R1234yf is detected in the system
- Offers maximum protection of the A/C service unit
- Safe analysis via LP coupling
- Plug and play function allows immediate integration with the unit
- Simple, automatic operation and instant measurement result
- Fully automated control via integrated software process



Part number: 1010350393XX

Method B: flushing with flushing agent

Besides flushing the air conditioning system with refrigerant, it is also possible to flush with a special chemical flushing agent (in combination with compressed air) and blow the system out with nitrogen. This combination is the key to a

good result: the flushing agent ensures proper chemical cleaning while the nitrogen eliminates residues of the flushing agent and helps the system to dry out. During the blowing out/drying process, the connection lines and system

components are blown out individually with nitrogen. It is important to ensure that the maximum pressure while components are being blown out does not exceed 12 bar.



Advantages and disadvantages of the two flushing methods A and B:

Method A

Refrigerant

Flushing method

Using the MAHLE A/C service unit and an additional flushing device with filters and adapters, the system components are flushed against the direction of flow of the refrigerant (both available separately).

Advantages

- No costs for a separate flushing medium, as the existing refrigerant is used as the flushing medium
- No disposal costs for the flushing medium
- Removes loose dirt particles and oil
- Method is approved by different vehicle manufacturers

Disadvantages

- The filter element on the flushing unit must be replaced regularly
- The A/C service unit cannot be used for other purposes during the flushing process

Method B

Flushing agent

Flushing method

Using an additional flushing device and a chemical solution, the system components are flushed against the direction of flow of the refrigerant. Nitrogen must be used to remove the remaining flushing medium and dry the system.

Advantages

- Removes loose and embedded particles and oil

Disadvantages

- Costs of the flushing medium
- Disposal costs for the flushing medium
- Not approved by vehicle manufacturers

Contamination and effects

*What types of contamination can be removed by flushing?
What are the effects of these types of contamination?*

- Abrasion resulting from compressor damage
The material particles clog expansion valves, throttle valves (orifice tubes), or multiflow components (capacitor, evaporator).
- Moisture
Expansion valves and orifice tubes can freeze. Chemical reactions between refrigerants or refrigerant oils and moisture can lead to the formation of acids that cause hose lines and O-rings to become porous. As a result, the system components suffer corrosion damage.
- Elastomers (rubber)
The elastomer particles clog expansion valves, orifice tubes, and multiflow components.
- Contaminated refrigerant oil or refrigerant
Contaminated refrigerant or mixing of different refrigerants can result in the formation of acids. These can cause hose lines and O-rings to become porous. As a result, other system components may be damaged by corrosion.





MAHLE Aftermarket GmbH
Pragstraße 26-46
70376 Stuttgart/Germany
Phone: +49 711 501-0

www.mahle-aftermarket.com
www.mpulse.mahle.com