

SOGEVAC®

SV630 B (F) - SV750 B (F)

Single-stage, oil-sealed rotary vane pump

**Original Operating Instructions 300270020_002_C0
and spare parts list**

Part Numbers :

960 862

960 863

960 865

960 866

960 867

960 869

960 875

960877

and their variants



Contents

	Page
0 Important Safety Information	4
0.1 Mechanical Hazards	4
0.2 Electrical Hazards	4
0.3 Thermal Hazards	4
0.4 Hazards Caused by Materials and Substances	4
0.5 Danger of Pump Damage	5
1 Description	6
1.1 Principle of operation	6
1.2 Technical characteristics	7
1.3 Ordering Information	15
1.4 Connection fittings	17
1.5 Accessories	19
1.6 SV + WAU combinations	19
1.7 Spare parts	20
1.8 Lubricants	20
2 Transport and Storing	21
2.1 Transport and packaging	21
2.2 Mounting orientation	21
2.3 Storage	21
3 Installation	22
3.1 Installation	22
3.2 Connection to system	22
3.3 Electrical connections	27
3.4 Start-up	31
4 Operation	32
4.1 Operation	32
4.2 Switching off / Shutdown	33
4.3 Ultimate pump pressure	33
5 Maintenance	34
5.1 Safety Information	34
5.2 Maintenance Intervals	34
5.3 Leybold Service	35
5.4 Maintenance Work	35
6 Troubleshooting	43
7 Spare parts	45
8 Waste Disposal	54
EC Conformance Declaration	56

Safety Information

Obligation to Provide Information

Before installing and commissioning the pumps, carefully read these Operating Instructions and follow the information so as to ensure optimum and safe working right from the start.

The Leybold SOGEVAC® has been designed for safe and efficient operation when used properly and in accordance with these Operating Instructions. It is the responsibility of the user to carefully read and strictly observe all safety precautions described in this section and throughout the Operating Instructions. The SOGEVAC® must only be operated in the proper condition and under the conditions described in the Operating Instructions. It must be operated and maintained by trained personnel only. Consult local, state, and national agencies regarding specific requirements and regulations. Address any further safety, operation and/or maintenance questions to our nearest office.

DANGER indicates an imminently hazardous situation which, if not avoided, will result in death or serious injury.

WARNING indicates a potentially hazardous situation which, if not avoided, could result in death or serious injury.

CAUTION indicates a potentially hazardous situation which, if not avoided, could result in minor or moderate injury.

NOTICE is used to notify users of installation, operation, programming or maintenance information that is important, but not hazard related.

We reserve the right to modify the design and the specified data. The illustrations are not binding.

Retain the Operating Instructions for further use.

NOTICE



DANGER



WARNING



CAUTION



NOTICE



Safety Information



0 Important Safety Information

0.1 Mechanical Hazards

- 1 Never expose part of the body to the vacuum. There is a danger of injury. Never operate the pump with an open and thus accessible inlet. Vacuum connections as well as oil filling and oil draining openings must not be opened during operation of the pump.



0.2 Electrical Hazards

- 1 The electrical connection must only be provided by a trained person. Please observe the national regulations in the country of use like EN 50110-1 for Europe, for example.
- 2 Disconnect the unit from the power supply before starting any work.



0.3 Thermal Hazards

- 1 When operating pump is hot and some surfaces could reach a temperature higher than 80°C (176°F). There is a risk of burn by touching.



0.4 Hazards Caused by Materials and Substances

- 1 SOGEVAC® pumps are **not** designed:
 - for pumping of aggressive, corrosive, flammable or explosive gases or gases mixtures ;
 - for pumping of oxygen or other highly reactive gases with a greater concentration than atmospheric concentration (>20%) ;
 - for working in flammable or explosive environment.For all these cases, special materials must be used. In case of doubt, please contact Leybold.

See also the limits of use indicated in the CE declaration of conformity.

- 2 Depending on the process involved, dangerous substances and oil may escape from the pump. Take the necessary safety precautions !
 - 3 Take appropriate precautions to insure that the pump cannot start.
 - 4 If the pump has pumped hazardous gases it will be absolutely necessary to determine the nature of the hazard involved and take the appropriate safety precautions.
 - 5 Observe all safety regulations !
 - 6 Take adequate safety precautions prior to opening the intake or exhaust port.
 - 7 Respect the instructions concerning environment protection when discarding used oil or exhaust filters !
-

0.5 Danger of Pump Damage

- 1 Liquid and solid particles must not enter the pump. Install the adequate filters, separators and/or condensers. In case of doubt consult Leybold.
- 2 The intake line of the pump must never be connected to a device with over atmospheric pressure. Design the exhaust line so that no pressure higher than 1,15 bar abs. (0,15 bar rel.) can occur. Never work with closed or restricted pump exhaust.
- 3 Operating of the pump without oil or operating with incorrect direction of rotation can destroy the pump or lead to oil backstreaming.
- 4 Never use discarded seals. Always assemble using new seals.
- 5 The pump must be packaged in such a way that it will not be damaged during shipping, and so that no harmful substances can escape from the package.

NOTICE



Description

1 Description

SOGEVAC® pumps are designed for pumping of inert gases in the range of rough vacuum, between atmospheric pressure and end pressure of the pump.

When removing condensable vapours, a gas ballast valve (or 2) must be installed or opened.

1.1 Principle of operation

The SOGEVAC® is a single-stage, oil-sealed rotary vane pump.

The anti-suckback valve, gas ballast valve, exhaust filters, oil feedback circuit, oil cooler and thermal switch are integrated functional elements. The pump is driven by a foot-mounted motor via four V-belts.

The rotor mounted eccentrically in the pump cylinder has three vanes which divide the pump chamber into several compartments. The volume of each changes periodically with the rotation of the rotor.

As a result of enlargement of the pump chamber that is open in the direction of the intake port, gas is sucked in. The gas passes through the dirt trap and the open antisuckback valve and enters the pump chamber. As the rotor rotates further, the vane separates part of the pump chamber from the intake port. This part of the pump chamber is reduced, and the gas is compressed. At slightly above atmospheric pressure the gas is expelled from the chamber via the exhaust valves.

Oil injected into the pump chamber serves to seal, lubricate and cool the pump.

The oil entrained with the compressed gas is coarsely trapped in the bottom part of the oil casing. Then fine filtering occurs in the 8 integrated exhaust filter elements.

The proportion of oil in the exhaust gas is thus reduced below the visibility threshold (over 99 % entrapment rate).

The oil trapped in the exhaust filters is returned to the stator via an oil return line. To prevent gas flowing at atmospheric pressure from the oil reservoir into the intake port, the oil return line is controlled by a float valve.

The oil cycle of the SOGEVAC® is maintained by the pressure difference existing between the oil casing (pressure above atmospheric pressure) and the intake port (pressure below atmospheric pressure).

Unintentional venting of the vacuum chamber as well as oil suckback when switching off the pump are prevented by the built-in anti-suckback valve. Nevertheless, the anti-suckback valve does not guarantee the same safety as a valve.

As an additional failsafe device a thermal switch is incorporated ; it measures the temperature of the vacuum generator exhaust.

1.2 Technical characteristics

SV630 B AIR

Technical data		50 Hz	60 Hz
Pumping speed ¹⁾	m ³ . h ⁻¹	640	755
Ultimate total pressure without gas ballast ¹⁾	mbar	≤ 8.10 ⁻²	≤ 8.10 ⁻²
Ultimate total pressure with 1 gas ballast ¹⁾	mbar	≤ 0,7	≤ 0,7
Ultimate total pressure with 2 gas ballasts ^{1) 4)}	mbar	≤ 2	≤ 2
Water vapour tolerance:	mbar		
■ without gas ballast			
■ with 1 gas ballast ^{1) 3)}		40	50
■ with 2 gas ballasts ^{1) 3) 4)}		60	70
Water vapour capacity:	kg.h ⁻¹		
■ without gas ballast			
■ with 1 gas ballast ^{1) 3)}		17	24
■ with 2 gas ballasts ^{1) 3) 4)}		26	34
Noise level ²⁾	dB (A)	72	75
Type of protection/Isolation		IP 54/F	IP 54/F
Rated rotational speed pump	min ⁻¹	820	1000
Weight (with oil filling)	kg	730	730
Oil capacity min./max.	l	20/23	20/23
Intake connection		DN100 PN10	100 ISOK
Exhaust connection		Option	
Thermal switch (pump)		YES	YES

1) to DIN 28400 and following numbers, with standard gas-ballast

2) operated at the ultimate pressure without gas-ballast, free-field measurement at a distance of 1 m

3) please contact Leybold

4) option

Description

SV630 B - SV750 B

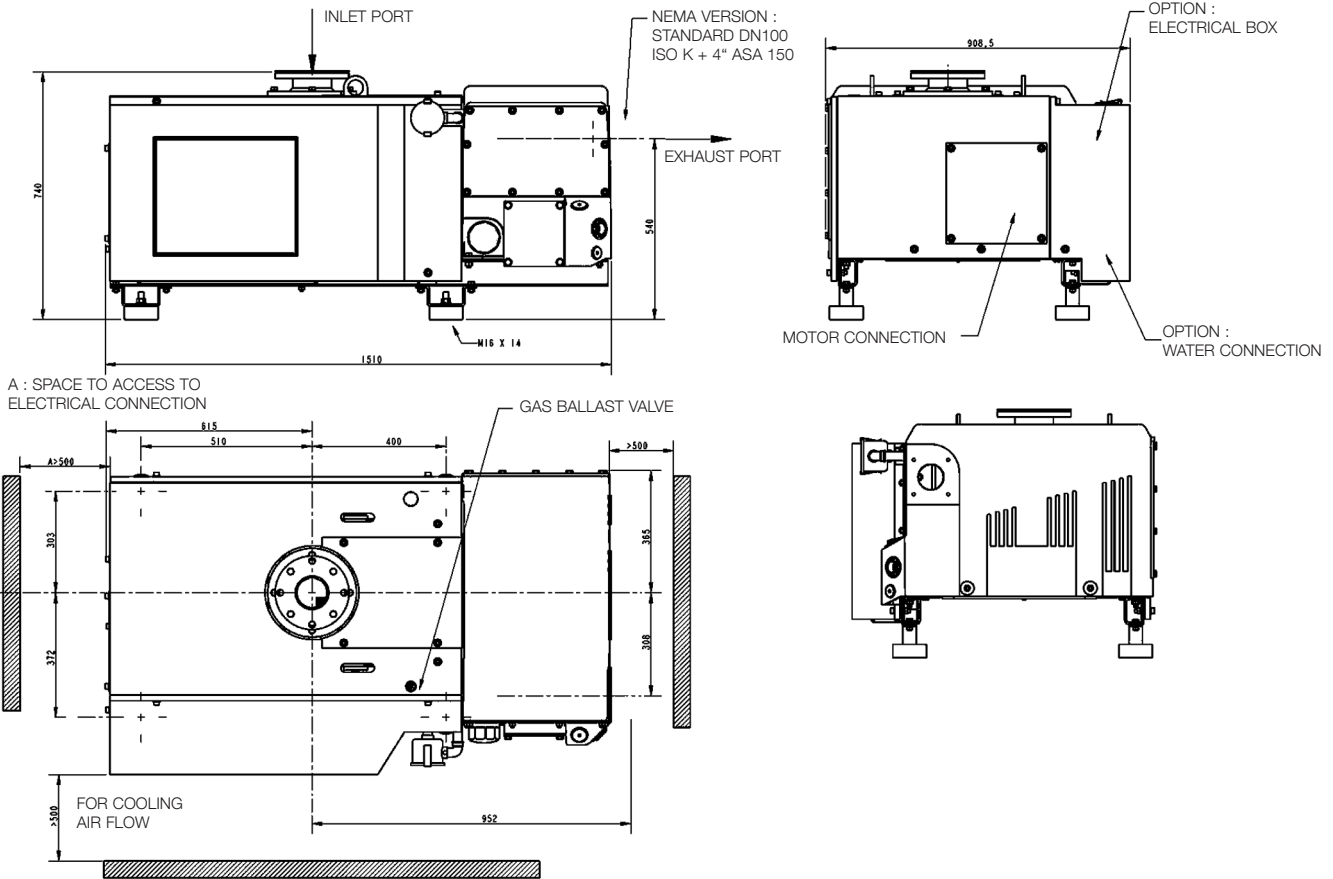

Pumping speeds SV630 B - SV750 B (use 60 Hz curves)

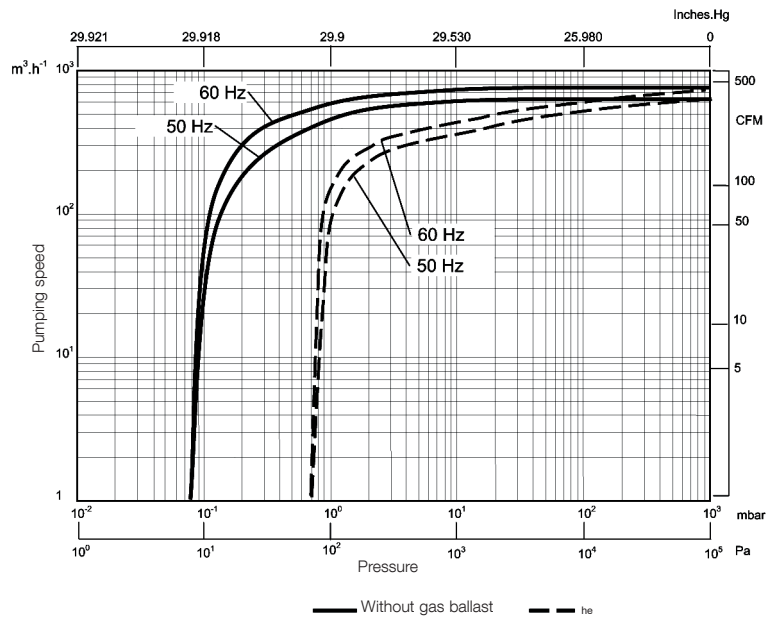

fig. 1

SV630 BF WATER

Technical data		50 Hz	60 Hz
Pumping speed ¹⁾	m ³ . h ⁻¹	640	755
Ultimate total pressure without gas ballast ¹⁾	mbar	≤ 8.10 ⁻²	≤ 8.10 ⁻²
Ultimate total pressure with 1 gas ballast EM ¹⁾ 24 VDC	mbar	≤ 0,7	≤ 0,7
Ultimate total pressure with 2 gas ballasts EM 24 VDC ^{2) 4)}	mbar	≤ 2	≤ 2
Antisuckback valve 24 VDC		YES	YES
Water vapour tolerance:	mbar		
■ without gas ballast			
■ with 1 gas ballast ³⁾		25	30
■ with 2 gas ballasts ^{1) 4)}		35	40
Water vapour capacity:	kg.h ⁻¹		
■ without gas ballast			
■ with 1 gas ballast ^{1) 3)}		11	14
■ with 2 gas ballasts ^{1) 3) 4)}		15	19
Cooling		H ₂ O	H ₂ O
Thermostatic valve		YES	YES
Water quality	TH (°F)	4 - 8	4 - 8
Water pressure min./max. see § 3.2 for water consumption	bar	2/8	2/8
Noise level ²⁾	dB (A)	72	72
Type of protection/Isolation		IP 54/F	IP 54/F
Rated rotational speed pump	min ⁻¹	820	1000
Weight (with oil filling)	kg	730	730
Oil capacity min./max.	l	20/23	20/23
Intake connection 2001		DIN 160 Roots adapter	
Exhaust connection		DIN 100 ISO K	
Thermal switch pump		YES	YES
Thermal switch motor		YES	YES

1) to DIN 28400 and following numbers, with standard gas-ballast

2) operated at the ultimate pressure without gas-ballast, free-field measurement at a distance of 1 m

3) please contact Leybold

4) option

Description

SV630 BF / SV750 BF

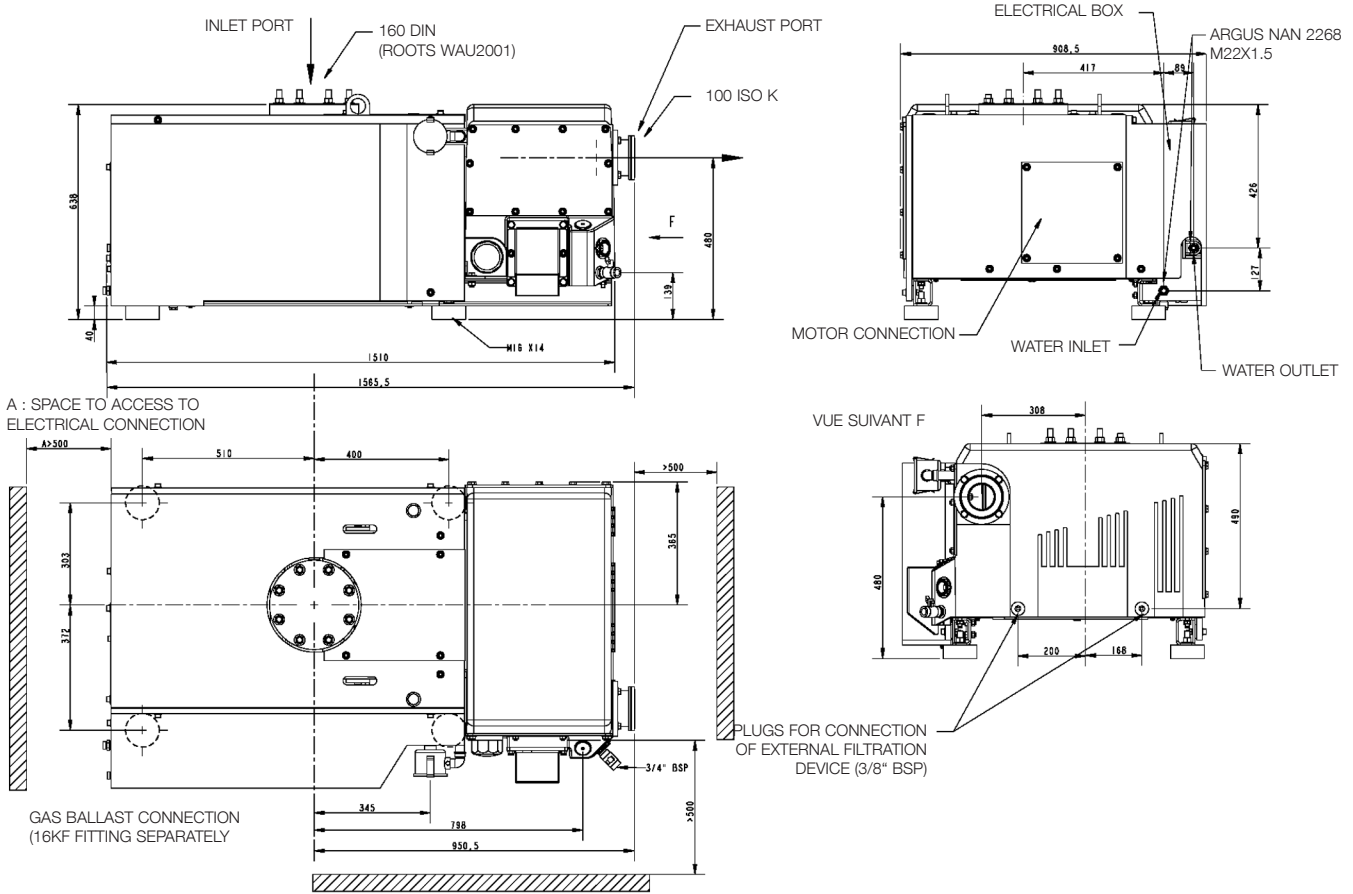

Pumping speeds SV630 BF - SV750 BF (use 60 Hz curves)

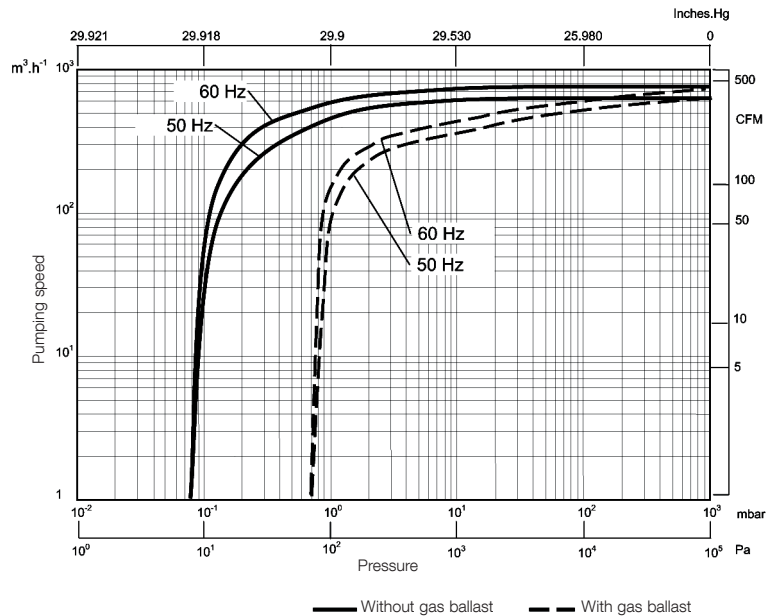

fig. 2

SV750 B AIR

Technical data		50 Hz
Pumping speed ¹⁾	m ³ · h ⁻¹	755
Ultimate total pressure without gas ballast ¹⁾	mbar	≤ 8 · 10 ⁻²
Ultimate total pressure with 1 gas ballast standard ¹⁾	mbar	≤ 0,7
Ultimate total pressure with 2 gas ballasts standard ^{1) 4)}	mbar	≤ 2
Water vapour tolerance:	mbar	
■ without gas ballast		
■ with 1 gas ballast ^{1) 3)}		50
■ with 2 gas ballasts ^{1) 3) 4)}		70
Water vapour capacity:	kg · h ⁻¹	
■ without gas ballast		
■ with 1 gas ballast ^{1) 3)}		24
■ with 2 gas ballasts ^{1) 3) 4)}		34
Noise level ²⁾	dB (A)	75
Type of protection/Isolation		IP 54/F
Rated rotational speed pump	min ⁻¹	1000
Weight (with oil filling)	kg	750
Oil capacity min./max.	l	20/23
Intake connection		DN 100 PN 10 100 ISOK
Exhaust connection		option
Oil cooler		
Thermal switch (pump)		YES
Thermal sensors motor		YES

1) to DIN 28400 and following numbers, with standard gas-ballast

2) operated at the ultimate pressure without gas-ballast, free-field measurement at a distance of 1 m

3) please contact Leybold

4) option

Description

SV750 BF WATER

Technical data		50 Hz
Pumping speed ¹⁾	m ³ . h ⁻¹	755
Ultimate total pressure without gas ballast ¹⁾	mbar	≤ 8.10 ⁻²
Ultimate total pressure with 1 gas ballast EM ¹⁾ 24 VDC	mbar	≤ 0,7
Ultimate total pressure with 2 gas ballasts EM 24 VDC ^{1) 4)}	mbar	≤ 2
Antisuckback valve 24 VDC		YES
Water vapour tolerance:	mbar	
■ without gas ballast		
■ with 1 gas ballast ³⁾		30
■ with 2 gas ballasts ^{3) 4)}		40
Water vapour capacity:	kg.h ⁻¹	
■ without gas ballast		
■ with 1 gas ballast ^{1) 3)}		14
■ with 2 gas ballasts ^{1) 3) 4)}		19
Cooling		H ₂ O
Thermostatic valve		YES
Water quality	TH (°F)	4 - 8
Water pressure min./max. see § 3.2 for water consumption	bar	2/8
Noise level ²⁾	dB (A)	72
Type of protection/Isolation		IP 54/F
Rated rotational speed pump	min ⁻¹	1000
Weight (with oil filling)	kg	750
Oil capacity min./max.	l	20/23
Intake connection		DIN 160 Roots adapter 2001
Exhaust connection		DIN 100 ISO K
Thermal switch pump		YES
Thermal switch motor		YES

1) to DIN 28400 and following numbers, with standard gas-ballast

2) operated at the ultimate pressure without gas-ballast, free-field measurement at a distance of 1 m

3) please contact Leybold

4) option

SV630 B US/AIR (60 Hz)

Technical data		60 Hz
Pumping speed ¹⁾	cfm	444
Ultimate total pressure without gas ballast ¹⁾	Torr	≤ 0.06
Ultimate total pressure with 1 gas ballast standard ¹⁾	Torr	≤ 0.5
Ultimate total pressure with 2 gas ballasts standard ^{1) 4)}	Torr	≤ 1.5
Water vapour tolerance:	Torr	
■ without gas ballast		
■ with 1 gas ballast ¹⁾		37
■ with 2 gas ballasts ^{1) 4)}		52
Water vapour capacity:	qt/hr	
■ without gas ballast		
■ with 1 gas ballast ^{1) 3)}		25
■ with 2 gas ballasts ^{1) 3) 4)}		35
Noise level ²⁾	dB (A)	75
Motor power	hp	25
Type of protection/Isolation		TEFC / F
Rated rotational speed pump	rpm	1000
Weight (with oil filling)	lb	1678
Oil capacity min./max.	qt	21/24
Intake connection		4" ASA 150 / 100 ISOK
Exhaust connection		4" ASA 150 / 100 ISOK
Thermal switch (pump)		YES
Thermal sensors motor		YES

1) to DIN 28400 and following numbers, with standard gas-ballast

2) operated at the ultimate pressure without gas-ballast, free-field measurement at a distance of 1 m

3) please contact Leybold

4) option

Conversion factors	Different pressure units				Different pumping speed units		
	Mbar (millibar)	torr	inches Hg vacuum		m ³ .h ⁻¹	l.s ⁻¹	cfm
1 lb = 0.453 kg	1013	760	0	m ³ . h ⁻¹ = m ³ /h	1	0.278	0.589
1 qt = 0.946 l	400	300	18.12				
1 hp = 0.735 kW	133	100	25.98	l.s ⁻¹ = l/s	3.60	1	2.12 1 r.p.m.
= 1 min ⁻¹	4	3	29.80				
1 pouce = 25.4 mm	1	0.75	29.89	cfm (cubic feet per minute)	1.699	0.472	1
	0	0	29.92				
1 atm (atmosphere) = 1013 mbar				Example : 1 m ³ .H ⁻¹ = 0.589 cfm			
1 Pa (pascal) = 0.01 mbar = 10 ⁻² mbar							
1 bar = 1000 mbar							
1 torr = 1.33 mbar							

Description

SV630 BF US WATER (60 Hz)

Technical data		60 Hz
Pumping speed ¹⁾	cfm	444
Ultimate total pressure without gas ballast ¹⁾	Torr	0.06
Ultimate total pressure with 1 gas ballast EM ¹⁾ 24 VDC	Torr	≤ 0.5
Ultimate total pressure with 2 gas ballasts EM 24 VDC ^{1) 4)}	Torr	≤ 1.5
Antisuckback valve 24 VDC		OUI
Water vapour tolerance:	Torr	
■ without gas ballast		
■ with 1 gas ballast ³⁾		22,5
■ with 2 gas ballasts ^{3) 4)}		30
Water vapour capacity:	qt/hr	
■ without gas ballast		
■ with 1 gas ballast ^{1) 3)}		15
■ with 2 gas ballasts ^{1) 3) 4)}		20
Cooling		H2O
Thermostatic valve		YES
Water quality	TH (°F)	4 - 8
Water pressure min./max.	PSI	29/114
Noise level ²⁾	dB (A)	72
Motor power	HP	25
Type of protection/Isolation		TEFC / F
Rated rotational speed pump	rpm	1000
Weight (with oil filling)	lb	1678
Oil capacity min./max.	qt	21/24
Intake connection		DIN 160 Roots adapter 2001
Exhaust connection		DN 100 ISOK
Thermal switch Pump		YES
Thermal switch Motor		YES

1) to DIN 28400 and following numbers, with standard gas-ballast

2) operated at the ultimate pressure without gas-ballast, free-field measurement at a distance of 1 m

3) please contact Leybold

4) option

1.3 Ordering Information

SV630 B

Options	960 862	960 863	960 865
Intake connection	DN 100 PN10 DN 100 ISO-K	DN 100 PN10 DN 100 ISO-K	4" ASA 150 / DN 100 ISO-K
Exhaust connection	Option	Option	4" ASA 150 / 100 ISO-K
Gas ballast	Manual	Manual	Manual
Anti-suckback valve	Standard	Standard	Standard
Mains voltage	200 V \pm 10%, 50 Hz 18,5 kW JIS	380 V \pm 10%, 50 Hz 400 V \pm 10%, 50 Hz 690 V \pm 10%, 50 Hz 415 V \pm 10%, 50 Hz	400 V \pm 10%, 50 Hz 25 hp NEMA PREMIUM
	200 V \pm 10%, 60 Hz 18,5 kW	440 V \pm 10%, 60 Hz 460 V \pm 10%, 60 Hz 17 kW	230 V \pm 10%, 60 Hz 460 V \pm 10%, 60 Hz 25 hp
PTC thermistors	YES	YES	YES

SV630 BF

Options	960 866	960 867	960 869
Intake connection	DIN 160 Roots Adapter 2001		
Exhaust connection	DN 100 ISO-K	DN 100 ISO-K	DN 100 ISO-K
Gas ballast	24 VDC	24 VDC	24 VDC
Anti-suckback valve	24 VDC	24 VDC	24 VDC
Mains voltage	200 V \pm 10%, 50 Hz 18,5 kW JIS	380 V \pm 10%, 50 Hz 400 V \pm 10%, 50 Hz 690 V \pm 10%, 50 Hz 415 V \pm 10%, 50 Hz 15 kW	400 V \pm 10%, 50 Hz 25 hp NEMA PREMIUM
	200 V \pm 10%, 60 Hz 18,5 kW	440 V \pm 10%, 60 Hz 460 V \pm 10%, 60 Hz 17 kW	230 V \pm 10%, 60 Hz 460 V \pm 10%, 60 Hz 25 hp
PTC thermistors	YES	YES	YES

Description

SV750 B (F)

Options	960 875	960 877
Intake connection	DN 100 PN10 DN 100 ISO-K	DIN 160 Roots adapter 2001
Exhaust connection	Option	DN 100 ISO-K
Gas ballast	Manual	24 V DC
Anti-suckback valve	Standard	24 V DC
Mains voltage	380 V \pm 10%, 50 Hz 400 V \pm 10%, 50 Hz 690 V \pm 10%, 50 Hz 415 V \pm 10%, 50 Hz 18,5 kW	380 V \pm 10%, 50 Hz 400 V \pm 10%, 50 Hz 690 V \pm 10%, 50 Hz 415 V \pm 10%, 50 Hz 18,5 kW
PTC thermistors	YES	YES

1.4 Connection fittings

Rep.	Specification	Size	Cat. Nr.
1	PVC tube	Ø 90	711 18 329
2	Adapter for tube	DN 90 - 100 PN 10	711 18 362
3	Elastic coupling	Ø 100 - PN 10	711 18 342
4	Adapter flange	DN 100 PN 10-4" BSP	711 18 372
5	Adapter flange	DN 100 PN 10-3" BSP	711 18 370
6	Adapter flange	4" BSP M/DN 90	711 18 017
7	Roots Adapter	Roots 1001	9 714 32 340
	Roots Adapter	Roots 2001	9 714 32 350
	Adapter (not represented)	DN100 PN10 100 ISO K	711 18 336
	Screwsset*		714 12 440
8	O Ring (NBR)	DN 110x5	712 42 882
9	Centering Ring + O Ring (NBR)	100 ISO K, 100 PN 10	711 18 391
10	Elbow 90°	DN 100 PN 10	711 18 284
11	Filter (Paper)	F 400 - 630 P	951 71
	Filter (Metal)	F 400 - 630 M	711 27 163
	Filter (Activated charcoal)	F 400 - 630 CA	711 27 162
	Filter (Polyester)	F 400 - 630	711 27 164
12	Hand valve	DN 100	711 30 116
13	EP valve	DN 100	Option**
14	Adapter flange	Ø 100 PN 10 - NFE 29222	711 18 351
15	Adapter flange	DN 100 PN 10 - 100 ISO K	711 18 383
16	Ball valve	1/2" BSP M/F	711 30 113
17	Manometer	Ø 1/2" BSP M	951 92
18	Elbow 90°	100 ISO K	887 26
19	Set of 4 clamps for ISO K flanges	M 10 x 24	26 701
20	Centering ring	100 ISO K AL/NBR	26 808
21	Filtre (Paper)	100 ISO K	951 72
	Filtre (Metal)	100 ISO K	711 27 167
	Filter (Activated charcoal)	100 ISO K	711 27 166
	Filtre (Polyester)	100 ISO K	711 27 168

* 8 Screws and nuts for DN100 PN10 connection fittings

** Please contact Leybold

Description

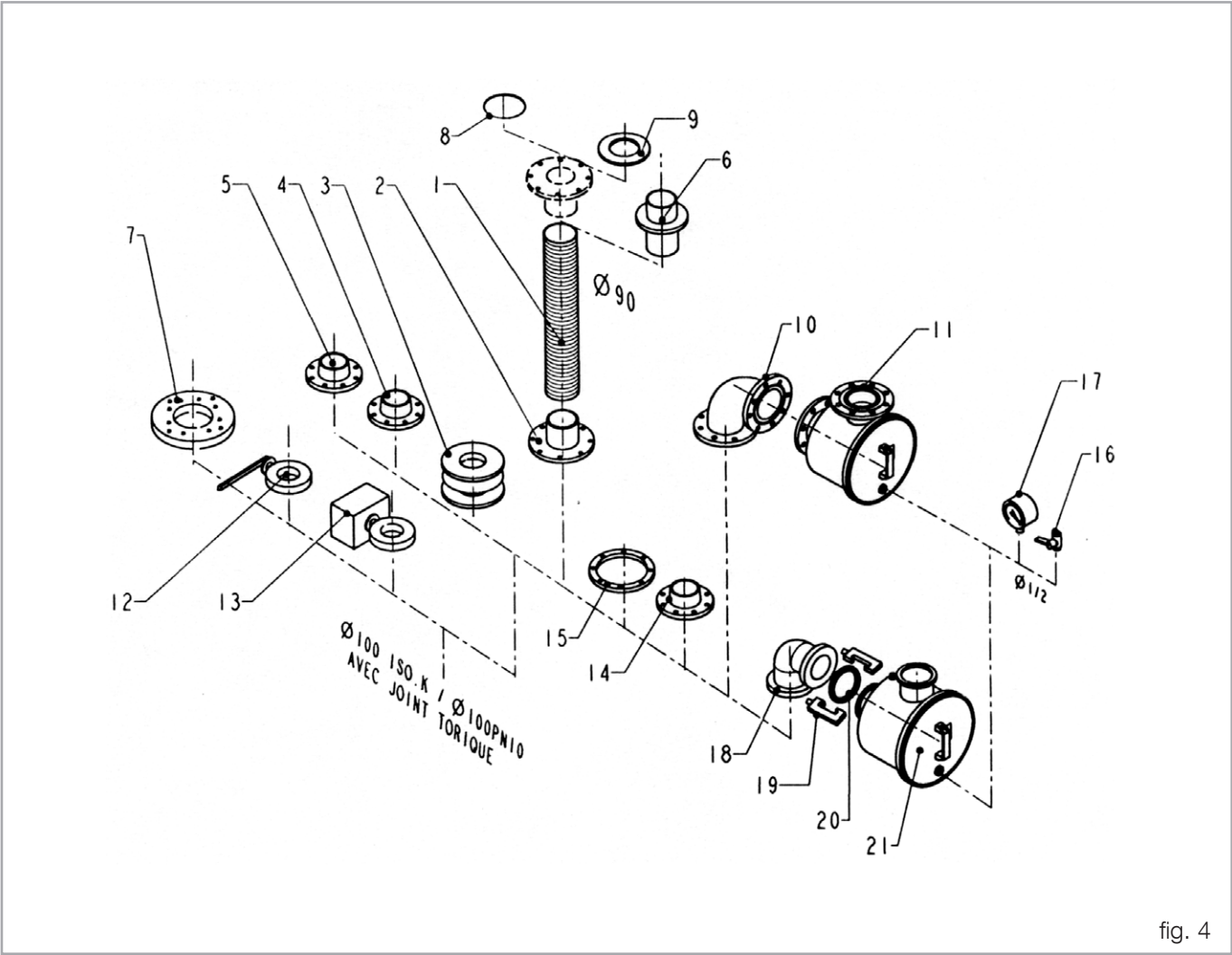

fig. 4

1.5 Accessories

	SV630 B - SV750 B	SV630 BF -S V750 BF	
Specification	Size	Cat. Nr.	Cat. Nr.
Oil drain tap		711 30 114	Standard
EM gas ballast kit	24 V DC	9 714 38 170	9 714 38 170
Gas ballast standard (manual)		9 714 46 490	9 714 46 490
2 EM gas ballasts	24 V DC		9 714 38 160
2 gas ballasts (manual)		9 714 38 340	9 714 38 340
Exhaust filter gauge (manometer)		951 94	951 94
Oil level monitor		9 714 25 760	9 714 25 760
Thermal switch 115° C	Standard	9 714 30 630	9 714 40 000
Inlet kit 100 ISOK		Standard	9 714 30 550
Water cooling with thermostatic valve		On request	Standard
Oil filter by-pass		712 36 390	712 36 390
Exhaust filter over pressure switch		712 22 360	712 22 360

Operation of pump is insured with accessories of Leybold: mounting any other accessory will engage the responsibility of user concerning operation of pump.

1.6 SV + WAU combinations

	SV630 B - SV750 B	SV630 BF - SV750 BF	
Specification	Size	Cat. Nr.	Cat. Nr.
Adapter Roots 1001		9 714 32 340	9 714 32 340
Adapter Roots 2001		9 714 32 350	Standard
Adapter Roots 4400		97143WH4400	97143WH4400

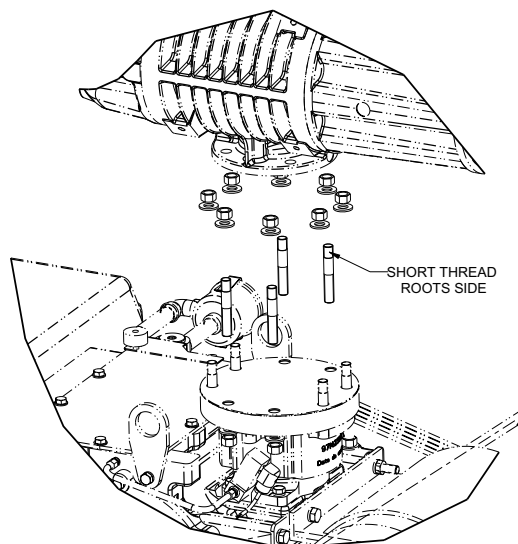

Description

1.7 Spare parts

		SV630 B	SV630 BF	SV750 B
Specification	Size	Cat. Nr.	Cat. Nr.	Cat. Nr.
Oil filter standard		714 05 310	714 05 310	714 05 310
Exhaust filter (Quantity per pump)		9 714 31 120 8	9 714 31 120 8	9 714 31 120 8
Set of seals	FPM	9 714 37 310	9 714 37 310	9 714 37 310
Repair set		9 714 37 320	9 714 37 320	(1)
Module kit		9 714 37 330	9 714 37 330	(1)
Service kit		9 714 37 340	9 714 37 340	9 714 37 340
Inlet filter element				
■ paper		710 35 242	710 35 242	710 35 242
■ metal		710 37 734	710 37 734	710 37 734
■ charcoal		710 37 724	710 37 724	710 37 724
■ polyester		712 61 508	712 61 508	712 61 508

1) Upon request

1.8 Lubricants

The SOGEVAC® pumps should be run with mineral oils for vacuum pumps with low viscosity according to ISO category VG77. The Leybold oil fulfills these specifications.

LVO130 Oil :	Conditioning	Reference
	2 l	L13002
	5 l	L13005
	20 l	L13020
	200 l	L13099

You may use other Leybold lubricants adapted to the applications. Please consult us.

The use of non Leybold oils can change the pump performance and may cause damage or reduce the maintenance intervals.

If non Leybold oils are used during the warranty period, Leybold may reject any warranty claim.

2 Transport and Storing

2.1 Transport and packaging

SOGEVAC® vacuum pumps pass a rigorous operating test in our factory and are packaged to avoid transport damages.

Please check packaging on delivery for transport damages.

Packing materials should be disposed off according to environmental laws or re-cycled. These operating instructions are part of the consignment.

The pump is delivered enclosed in a plastic foil with 5 dessicant bags inside.

The connection ports are blanked off by plastic protective caps or self-adhesives. Take these caps or self-adhesives away before turning on the pump.

The pumps have the oil filled in.

2.2 Mounting orientation

See required space on drawings in paragraph 1.2.

Pumps which have been filled with oil must only be moved in the upright position (horizontally). Otherwise oil may escape. The angle of slope may not be over 10° max. Avoid any other orientations while moving the pump.

Only use the lifting lugs which are provided on the pump to lift the pump with the specified lifting devices.

Make sure that these have been installed safety. Use suitable lifting equipment. Make sure that all safety regulations are observed.

Use only lifting devices appropriated to the pump weight. Check name plate. Do not use other pump elements than the lifting lugs as handles.

2.3 Storage

Before stocking the pump for a long time put it back in its original condition (blank off inlet and exhaust ports with the shipping seals, drain the oil) and store the pump in a dry place at room temperature.

Until the pump is put back in to service again, the pump should be stored in a dry place, preferably at room temperature (20 °C - 168 °F). Before taking the pump out of service, it should be properly disconnected from the vacuum system, purged with dry nitrogen and the oil should be exchange too. Drain the water from the cooling circuit (See § 3.2). The gas ballast must be closed and if the pump is to be shelved for a longer period of time is should be sealed in a plastic bag together with a desiccant (Silicagel).

If the pump has been shelved for over one year, standard maintenance must be done and the oil must be exchanged too before the pump is put in to service once more.

We recommend that you contact the service from Leybold.

NOTICE



Installation



3 Installation

It is essential to observe the following instructions step by step to ensure safe start-up. Start-up may only be conducted by trained specialists.

The standard pump is not suitable for installation in explosion hazard areas ATEX. Please contact us, if you are planning such an application. Before installing the pump you must reliably disconnect it from the electrical power supply and prevent the pump from running up inadvertently.

Observe all safety regulations.

3.1 Installation

The SOGEVAC® can be set up on any flat, horizontal surface. Under the four feet, there are metric threaded holes (M16x1.4) for securing the pump.

The oil level cannot be read properly if the pump is tilted and lubrication may be affected.

NOTICE



The pump's ambient temperature should be between 12°C (55°F) and 40°C (104°F). By modifying the pump or changing the oil type, the pump can be run at a other ambient temperature. Please consult us.

To ensure adequate cooling of the pump, leave enough space at the air intake and exhaust points, and for access and maintenance (see Fig. 1-2-3).

Make sure to keep the pump and air intake of the motor clean.

3.2 Connection to system

The standard pump is not suitable for installation in explosion hazard areas ATEX. Please contact us, when you are planning such an application.

Intake Side

NOTICE



Pump should be connected to inlet line without any tension. Use flex lines or pipe unions in your inlet and exhaust lines so that they can be easily removed for pump maintenance.

The maximum pressure at the inlet may not exceed atmospheric pressure (about 1013 mbar). Never operate the pump in the presence of over pressures at its intake.

Type of materials used for mounting of pipings should take care of pumped gases. It is the same for its tightness.

The pump is equipped with an inlet flange 100 ISO K/DN 100 PN 10 (SV630 B / SV750 B) or DIN 160 roots adapter (SV630 BF / SV750 BF). Using suitable connecting elements (see § 1.4) the pump can be connected to the vacuum system.

The cross-section of the intake line should be at least the same as the one for the intake port. If the intake line is too narrow, it reduces the pumping speed.

If the process gas contains dust, it is absolutely essential to install a dust filter in addition to the dirt trap supplied (see §1.4).

We recommend to install the dust filter horizontally. This ensures that when removing the filter no particles fall into the intake port.

When pumping vapors, we recommend installing condensate traps on the intake and exhaust sides

The intake must be installed in such a way to avoid condensates flowing into the pump.

Exhaust Side

The SOGEVAC® pumps have integrated exhaust filters which, even at a high gas throughput, trap the oil mist and guarantee exhaust gas free of oil mist. If the exhaust filters are clogged, the by pass opens at 1.5 bar, (absolute pressure), and the filters are bypassed. As a result, the proportion of oil in the exhaust gas as well as the pump's oil consumption will rise. Installing new exhaust filters will correct this problem. (See § 5.4).

Check in the individual case whether an line is necessary and/or prescribed. Volatile substances will pass through the filter. Depending on the process gas, we recommend connecting an exhaust line ; this is always necessary when the exhaust gases are dangerous.

The maximum exhaust pressure must neither exceed 1.15 bar absolute (0.15 bar relative), nor fall under atmosphere pressure minus 15 mbar.

Corresponding pressure regulating devices to be installed by the user.

Exhaust flanges

- The SV630 B (Euro-version) and the SV750 B are not equipped with outlet flange (only hole Ø 80). An outlet pipe can be connected through accessory : Exhaust kit DN 100 PN10, 100 ISO K : Cat. Nr. 9 714 38 540.
- SV630 BF / SV750 BF is in standard equipped with outlet flange DN 100 ISO K.

The diameter of the exhaust line should be at least Ø 100 mm. If the exhaust line is too narrow, overpressure or overheating may occur in the pump.

Before installing the exhaust line, remove the exhaust-flange plate and ensure that the exhaust demister(s) are secured tightly in place. They sometimes loosen during shipping and installation. A loose demister results in exhaust smoke during start-up and operation. Install the exhaust line with a downward slope to prevent condensate from flowing back into the pump. If this is not possible, we strongly recommend installing a condensate trap.

Never operate the pump with a blocked or restricted exhaust line. Before start-up, ensure that any blinds or similar shut-off devices in the exhaust line on the pressure side are opened and that the exhaust line is not obstructed.

Exhaust pipe material must be resistant to pumped gases.

NOTICE



NOTICE



Installation

Water cooling

The SOGEVAC® pumps are equipped, in standard for the SV630 BF & SV750 BF and as an option for the SV630 B/SV750 B, with a water cooling system and a thermostatic valve. Depending on the local regulations, the cooling water needed may not be taken from the drinking water mains and max. water temperatures must be observed. The water cooling connection is made by an ARGUS type 1/2» x M22 - 150 adapter delivered separately or by a female G 1/2 connection.

The thermostatic valve regulates the cooling water throughput, and so the pump temperature. The valve is set in standard on position 1. Rated pump performance is achieved on position 1 or 2. On higher positions, ultimate pressure may degrade.

Normally, the thermostatic valve should be set somewhere in the range from 1 to 3. Thermostat setting 1 (valve fully open) produces a low operating temperature of the pump, and setting 3 a high one.

Pumping on vapors requires setting on position 3. Do not use positions 4 and 5.

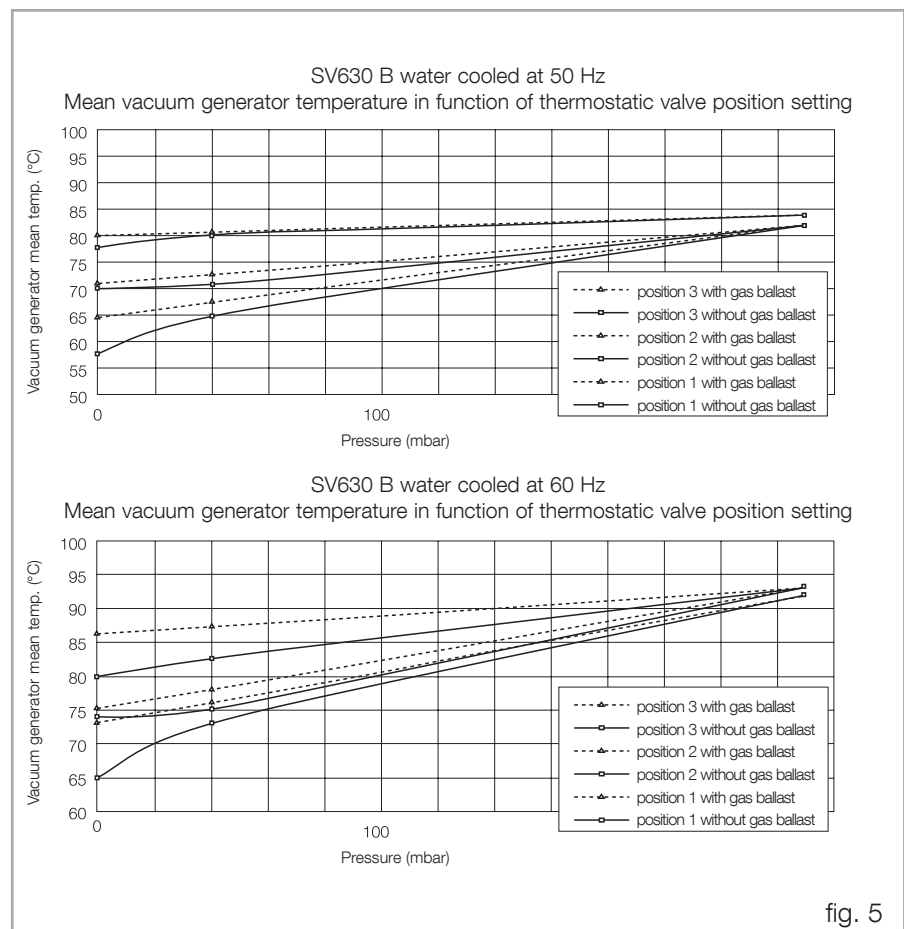

Water Quality

In order to ensure long trouble-free operation the cooling water must not contain any oils, greases and suspended solids. Moreover, we recommend compliance with the following limit values:

Position thermo. valve		50 Hz				60 Hz			
		Ultimate pr.	40 mbar	Ultimate pr. and gas ballast	250 mbar and gas ballast	Ultimate pr.	40 mbar	Ultimate pr. and gas ballast	250 mbar and gas ballast
1	ΔT water (°C)	7	10	9	13	8	11	11	15
	δ H ₂ O (l/h)	643	667	668	656	690	668	676	685
	P (kW)	6	7	7	10	7	9	8	12
2	ΔT water (°C)	52	17	18	12	27	14	10	14
	δ H ₂ O (l/h)	99	307	292	726	181	511	718	730
	P (kW)	4	6	6	10	6	8	8	12
3	ΔT water (°C)	45	32	35	17	38	23	34	14
	δ H ₂ O (l/h)	78	158	139	462	129	276	185	703
	P (kW)	4	6	6	9	6	7	7	11

ΔT water (°C) : Cooling water temperature increase

δ H₂O (l/h) : Cooling water flow

P (kW) : Absorbed power by cooling water

Max. cooling water temperature : 30°C (86°F)

Water cooling

	TH (°f)	0°	4°	8°	12°	20°
Water quality		Corrosion (water too soft)		Service area		Incrusting water (deposit of scale)
Carbonat content	PPm	0	30	90	160	300
		Corrosion (water too soft)		Service area	Incrusting water	Very incrusting water
	PH	0	5	7,5		
		Corrosion (water too soft)		Service area	Incrusting water	

Water temperature at inlet	max. 30 °C (86 °F)
Appearance	Clear, free of oils and greases
Suspended matter	< 250 mg/l
Particle size	< 150 µm
Electrical conductivity	< 700 µS/cm
Aggressive carbon dioxide	None, not detectable
Chloride	< 100 mg/l
Sulfate	< 150 mg/l
Nitrate	≤ 50 mg/l
Iron	< 0.2 mg/l
Manganese	< 0.1 mg/l
Ammonium	< 1.0 mg/l

Installation

Free chlorine	< 0.2 mg/l
---------------	------------

If there is the danger of frost, you may use a water glycol mixture of up to 30 %.

Do not use deionised cooling water.

To clean the heat exchanger : it is recommended to clean at least twice a year the water circuit.

For that, dismantle the exchanger from the pump. Chemical cleaning is the most efficient, with dilute hydrochloric acid solution (5 to 10%) then neutralize with hexamethylethyrene tetramine at 0.2 %. For a 1 mm coat of scale, leave acting the acid during about 30 min.

The system must be open during the operations, so the product gases can escape. Rinse copiously with water after neutralization.



Proceed in an open and well ventilated place.

Observe the safety regulations given by the manufacturer of the product you are using.

Observe the regulations for the treatment and the disposal of chemical products.

Observe the relevant environmental regulations.

Draining of the water-cooling circuit (before transport, long time storage, winter time).

Remove the cover Item 55 and place a water recovery pan under the heat exchanger and unscrew the plug Item 57.

The heat exchanger water will drain.

To drain completely the heat exchanger:

- Remove the water outlet hose and close the water outlet with a plug.
- Remove the water inlet hose
- Connect a compressed air supply in place of plug Item 57 and blow.

Attention, water will be evacuated through the water inlet connection.

Reassemble in the reverse sequence.

3.3 Electrical connections

Ensure that incoming power to the pump is off before wiring the motor or altering the wiring.

DANGER

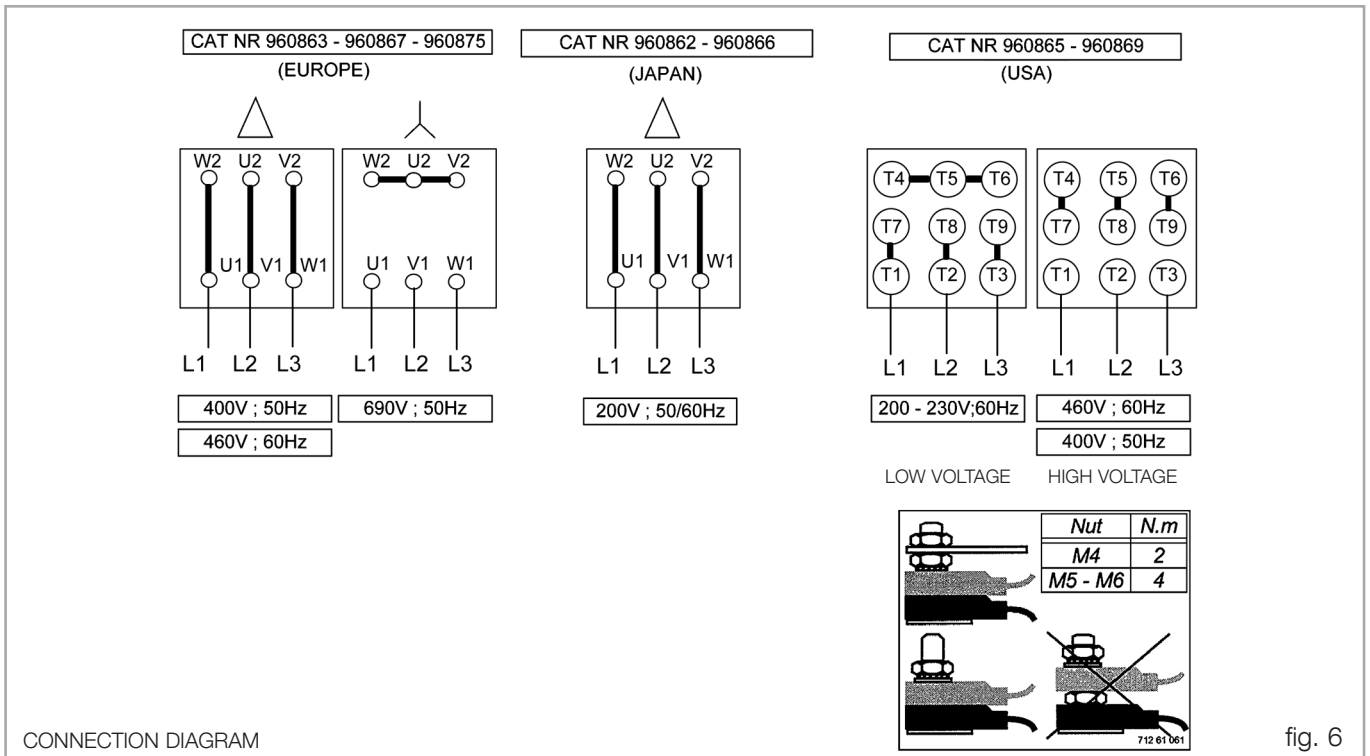

fig. 6

Electrical connection work must only be carried out by a qualified electrician in accordance with the applicable safety rules, see IEC 60204-1 & 61010-1.

Connect the pump's motor to the right supply voltage via the connections in the junction box (see fig. 6). The relevant safety rules require the use of a suitable motor protection switch. Set the switch in accordance with the rating on the motor nameplate.

If any security switch or electrical defect cuts out the pump, re-start-up of the pump has to be possible only manually.

CAUTION



Installation

Motor protection device

To protect the motor windings against a variety of operational malfunctions, the motor of the SV630 BF is fitted with protection devices.

PTC thermistors to IEC 60034-1 and DIN 44081/440823 are temperature - dependent, semi-conductor devices embedded in the motor windings.

Working principle

Non-linear variable resistors. It is recommended to connect them to the control circuit. PTC thermistors ensure a good protection against the overheating of the motor.

The pump is designed for direct starting even under load conditions, i.e. the pump can be switched on against vacuum in the intake port.

After connecting the motor and after every time you alter the wiring, check the direction of rotation. Refer to the marking on the motor. During the check, the intake port should be open. If the direction of rotation is wrong, oil may be ejected out the intake port. (The vacuum system may be pressurised).

For the check, switch on the motor briefly. If it starts up with the wrong direction of rotation, switch it off immediately and interchange two phases of the connection. It is recommendable to check the direction of rotation with a phase sequence indicator.

NOTICE



Prolonged running of the motor in the wrong direction of rotation will damage the pump !

Oil thermal Switch

Connection has to be made in the junction box (see fig. 7).

Breaking power on resistive circuit 25 VAC or 60 V DC max.

To be serial wired with the coil of motor's contactor. Use an auxiliary relay.

The pump is switched off once a certain oil temperature (115 °C/239 °F) is exceeded. It is also possible to connect an alarm system. (see fig. 7).

Motorization

European versions :

A 50/60 Hz motor is mounted in standard on the SV630 B and SV630 BF.

Voltages :

400 V $\pm 10\%$ at 50 Hz

460 V $\pm 10\%$ at 60 Hz

A motor working only at 50 Hz is mounted in standard on the SV750.B

Voltage :

400 V $\pm 10\%$ at 50 Hz

Japan versions :

A JIS 50/60Hz motor is mounted in standard on the SV630 B and SV630 BF. With PTC sensors.

Voltage :

200 V $\pm 10\%$ at 50 Hz and 60 Hz

US versions:

A NEMA motor is mounted in standard on the SV630 B and SV630 BF.

With PTC sensors.

Voltages :

400 V $\pm 10\%$ at 50 Hz

230 V/460 V $\pm 10\%$ at 60 Hz

Installation

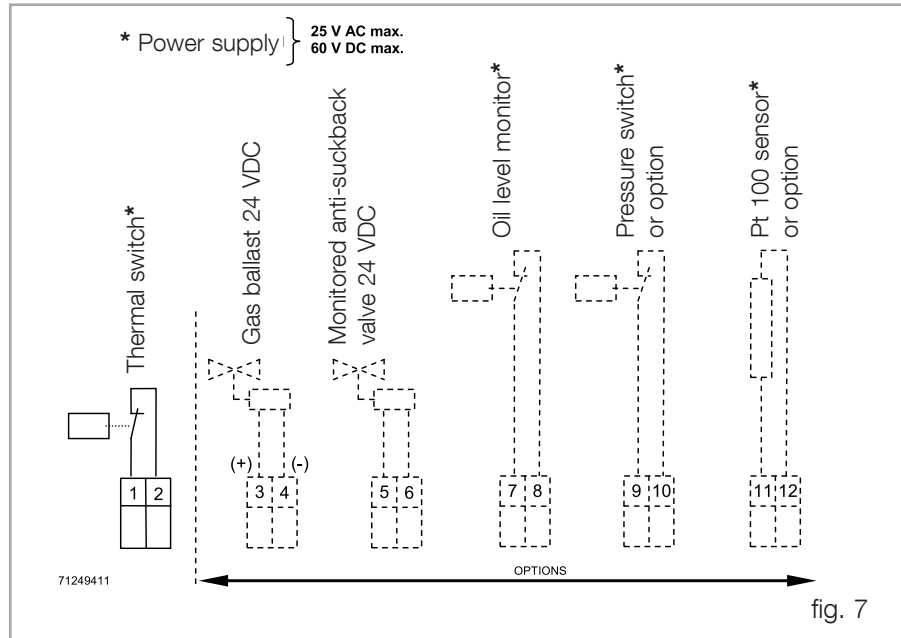

Particularities SV630 BF / SV750 BF

The pump is in standard equipped with options which have to be connected before starting up the pump:

Gas Ballast (EM Valve)

Normally closed (Power supply 24 V DC $\pm 10\%$)

To be wired in connection box (see fig. 7). Polarity must be respected.

Electromagnetic valve (antisuck-back valve)

Normally open

To be supplied in 24 V DC as soon as the pump starts. Shut down power supply as the pump stops.

If several pumps with EM antisuck-back valves are operated in parallel, there is a risk in case of V belt failure that the pump oil is sucked out. This can be prevented by using a valve on the intake port controlled by a motor cos phi controlling device.

The rotation detector P/N 9 714 48 780 can be used as well as a retrofit or on new pumps.

The electrical options installed on the pump are wired and have their respective connection terminals installed in the connection box.

Option : Oil level monitor

Reed contact	Power supply (max.)	Breaking power on resistiv circuit
AC 0.5 A	25 V	50 VA
DC 1.0 A	60 V	50 W

To be serial wired with the coil of motor's contactor (the pump stops in case of missing oil).

You must use imperatively an auxiliairy relay.

3.4 Start-up

The pumps are supplied with the necessary oil filling in ready-to-use condition. Always verify proper oil level before operating the pump.

The pump is designed for fail-safe start-up at temperatures over 12°C (55°F) (as per PNEUROP).

If local regulations provide a WYE-DELTA starting connect the pump to the system so that it can start loadfree, i.e. at atmospheric pressure in the intake port. If the vacuum system is not to be vented further measures will be necessary, e.g. a starting valve can be mounted. Please contact us in this case.

The signals of the oil level switch and exhaust filter over pressure switch must be delayed (timer) on the pump switch-on for approx. 1 minute.

SV630 BF / SV750 BF is equipped with :

- Electromagnetic gas ballast valve 24 V DC. Connection has to be made on junction box (see fig. 7).
- Antisuckback valve driven by EM valve DC. Connection has to be made on junction box (see fig. 7).

NOTICE



Operation

4 Operation

4.1 Operation

To avoid overloading the motor, do not start the pump more than 6 times within one hour.

If more than 6 starts per hour are necessary keep the pump running and mount a valve which opens and closes into the intake line.



CAUTION



Take note of warning labels on the pump.

Use ear protection in case of operation at high inlet pressures.

Pumping of non-condensable gases

If the pump system contains mainly non condensable gases, the pump should be operated without gas ballast.

If the composition of the gases to be pumped is not known and if condensation in the pump cannot be ruled out, run the pump with gas ballast valve open in accordance with section below.

Pumping of condensable gases and vapors

With the gas ballast valve open and at operating temperature, the SOGEVAC® can pump pure water vapor up to the values indicated in the Technical Data.

The gas ballast valve is opened by a screwdriver. The running noise of the pump is slightly louder if the gas ballast valve is open. Before pumping vapors ensure that the pump has warmed up for approx. 30 min. with closed intake line and with open gas ballast valve.

NOTICE



Don't open the pump to condensable vapors until it has warmed to operating temperature ; pumping process gas with a cold pump results in vapors condensing in the oil.

For processes with a high proportion of condensable vapors, the intake line should be opened only slowly after reaching the operating temperature.

One sign of condensation of vapors in the pump is a rise of the oil level during operation of the pump.

NOTICE



When vapors are pumped, the pump must not be switched off immediately after completion of the process because the condensate dissolved in the pump oil may cause changes or corrosion. To prevent this, the pump must continue to operate with open gas ballast valve and closed intake port until the oil is free of condensate. We recommend operating the pump in this mode for at least 30 min. after completion of the process.

In cycle operation, the pump should not be switched off between the cycles but should continue to run with gas ballast valve open and intake port closed (if possible via a valve). Power consumption is minimal when the pump is operating at ultimate pressure.

Once all vapors have been pumped off from a process (e. g. during drying), the gas ballast valve can be closed in order to improve the ultimate pressure.

4.2 Switching off / Shutdown

The intake port of the SOGEVAC® contains an anti-suckback valve which closes the intake port when the pump is switched off, thus maintaining the vacuum in the connected apparatus and preventing oil from being sucked back into the apparatus. The valve's functioning is not impaired by gas ballast operation.

If the pump has to be shutdown, drain the oil flush out the pump with fresh oil and fill in the required amount of clean oil (see § 5.4). Close the connection ports. Special preservation or flushing oils do not need to be used.

When the pump has been switched off due to over heating, initiated by the motor or its temperature detector, the pump must be cooled down to the ambient temperature, and must only be switched on again manually after having eliminated the cause.

NOTICE



In order to prevent the pump from running up unexpectedly after a mains power failure, the pump must be integrated in to the control system in such a way that the pump can only be started by a manually operated switch. This applies equally to emergency cut-off switches.

In case of switching processes in connection with a pump which has warmed up under operation conditions, the pump must then not be directly switched on again.

4.3 Ultimate pump pressure

If the values specified in the Technical Data are not reached in the apparatus, measure the ultimate pressure directly at the pump's intake port after disconnecting the pump from the apparatus.

The ultimate pressure of non-condensable gases (partial pressure of air) can only be measured with a compression vacuum gauge or a partial pressure gauge. Precise measurements can only be obtained with calibrated instruments.

Upon initial start-up, after prolonged idle periods or after an oil change, it takes a while until the pump reaches the specified ultimate pressure. The pump has to attain its operating temperature, and the pump oil has to be degassed. We recommend operating the pump initially with the gas ballast valve open.

The ultimate pressure depends on the pump temperature and the pump oil used. The best ultimate pressures can be obtained at a low pump temperature and by using the recommended oil types.

Maintenance

5 Maintenance

5.1 Safety Information

Depending on the process involved dangerous substances may escape from the pump and oil. Take the appropriate precautions.

Observe the safety regulations.

When disposing of used oil please observe the relevant environmental regulations !

All work must be done by suitably trained personnel. Maintenance or repairs carried out incorrectly will affect the life and performance of the pump and may cause problems when filing warranty claims.

Never mount used seals ; always mount new seals.

5.2 Maintenance Intervals

The intervals stated in the maintenance schedule are approximate values for normal pump operation. Unfavourable ambient conditions and/or aggressive media may significantly reduce the maintenance intervals.

Maintenance job	Frequency	Section
Check the oil level	Daily	A
Check the oil condition	Depends on process	B
1st oil change	After 150 h of operation	C
Subsequent oil changes	Every 2000 h or 6 months (depending on application)	C
Replace the oil filter	At each oil change	C
Replace the exhaust filter d'échappement	If oil mist at exhaust or annually	D
Clean the dirt trap	Monthly	E
Check the anti-suckback valve	Annually	F
Clean oil cooler	Annually	
Clean filter of gasballast	Monthly	G
Checking the float valve	When changing the exhaust filters	H
Replacing the exhaust valves	*	I
Replacing the pump module	*	J
Disassembling and reassembling the pump module	*	K
Control belts	6 months	L

* in case of specific pump servicing

To simplify the maintenance work we recommend combining several jobs.



5.3 Leybold Service

Whenever you send us in equipment, indicate whether the equipment is contaminated or is free of substances which could pose a health hazard. If it is contaminated, specify exactly which substances are involved. You must use the form we have prepared for this purpose.

A copy of the form has been reproduced at the end of these Operating Instructions: "Declaration of Contamination for Compressors, Vacuum Pumps and Components". Another suitable form is available from www.leybold.com → Documents → Download Documents.

Attach the form to the equipment or enclose it with the equipment.

This statement detailing the type of contamination is required to satisfy legal requirements and for the protection of our employees.

We must return to the sender any equipment which is not accompanied by a contamination statement.

The pump must be packaged in such a way that it will not be damaged during shipping, and so that no harmful substances can escape from the package.

When disposing of used oil, please observe the relevant environmental regulations.

Contamination

Form

CAUTION



5.4 Maintenance Work

Checking the oil

A. Oil level

The pump's oil level during operation must always be between the middle and top edge of the oil-level glass (164). When necessary, switch off the pump and add the correct quantity of oil.

High oil consumption often indicates that exhaust filters are clogged (See 5.4 - D).

The oil level should be checked at least once a day.

B. Oil Condition

Normally the oil is clear and transparent. If the oil darkens, it should be changed.

If gases or liquids are dissolved in the oil, the result is a deterioration of the ultimate pressure, the oil can be degassed by allowing the pump to run for about 30 min. with the intake port closed and the gas ballast valve open.

To check if oil should be changed, drain some oil via the oil-drain plug (5) into a beaker or similar container with the pump switched off but still at operating temperature.

Depending on the process involved, dangerous substances may escape from the pump and oil. Take the appropriate precautions.

Observe the safety regulations.

Maintenance

C. Oil Change, Replacing the Oil Filter (if installed)

Tool required : oil filter key (Ref. No. 710 73 532)

Always change the oil when the pump is switched off but still at working temperature.

If there is a risk of the oil being polymerized by the connected process, change the oil immediately after operation of the pump.

CAUTION



Pump when operating is hot and some surfaces could reach a temperature higher than 80° C (176 °F). There is a risk of burn by touching. Take note of the warning labels on the pump.

Unscrew the oil-drain plug (5) and let the used oil drain into a suitable container.

When the flow of oil slows down, screw the oil drain plug back in, briefly switch on the pump (max. 10s) and switch it off. Remove the oil drain plug again and drain the remaining oil.

Unscrew the oil filter (168). Take a new oil filter, moisten its gasket with oil and screw it in manually.

Reinsert the oil-drain plug.

Unscrew the oil-fill plug (122) and fill the pump with fresh oil up to the bottom edge of the oil level glass, run the pump for a short time and then change the oil again.

Use suitable oil only (see Section 1.8).

CAUTION



Clean any oil which is on the floor !
Check regularly that no oil is on the floor !

D. Replacing the exhaust filters and checking the by-pass

Tools required : tubular box wrench 16 mm.

When the exhaust filter elements are clogged, the integrated by-pass opens and the filters are bypassed. Oil mist at the exhaust, and/or high oil consumption are signs that the exhaust filters are clogged.

The exhaust filters must be replaced more often if subjected to increased oil cracking products at high operating temperatures and/or aggressive media.

Remove the cover (22) with gasket (106). Remove the exhaust deflector (162) by unscrewing the bolt (9).

Remove both demister support units (165) by unscrewing the nuts (11).

The exhaust filters (167) can be removed individually.

Check also the float valve (172). See § 5.4 - H.

Plug new exhaust filters (167) into the oil casing (160).

Insert carefully the demister support units (165) over the new exhaust filters (167) threaded bars (M6) and compress slightly the demister springs.

Tighten the demister support units (165) and the exhaust deflector (162). If necessary mount a new seal (106) and mount the cover (22).

E. Cleaning the dirt trap

Tools required : Open-jaw or box wrenches 10 mm, 17 mm.

A wire-mesh filter is located in the pump's intake port (43 or 67) to act as a dirt trap for impurities. It should be kept clean at all times in order to avoid reduction of the pumping capacity.

For this purpose, disconnect the intake line, remove the dirt trap from the intake port and rinse it in a suitable vessel using a solvent. Then dry it with compressed air. If the dirt trap is defective, replace it.

The cleaning intervals depend on requirements. If large amounts of abrasive materials occur, a dust filter should be fitted into the intake line (see § 1.4).

Maintenance

F. Checking the anti suckback valve

SV630 B Standard version - SV750 B

Tools required : Tubular box wrench 19 mm.

First remove the intake line and the intake flange (42 or 67).

Remove the 4 screws and take off the intake port.

Remove the anti-suckback valve (103 and 105), the spring and the gasket. Clean all parts and check that they are in perfect condition ; if not, replace them.

If the anti-suckback valve closes too early, carefully compress the spring slightly. The top edge of the valve should be about 1 mm away from the top side of the intake port.

Reassemble in the reverse order.

SV 630 BF - SV 750 BF

Anti-suckback valve is driven by a EM Valve 24 V DC.

G. Cleaning the gas ballast intake filter

When the pump operates with open gas ballast valve, clean the filter (127) once a month.

Release the clips on the gas ballast filter. Clean the filter using a suitable solvent. Then dry it. Reassemble in the reverse sequence.

H. Checking the float Valve

Tools required :

- Tubular box wrench SW16.
- Allen keys 4,6.

If the pressure does not fall below approx. 5 mbar (4 Torr) during pump operation, check the tightness of the float valve (172).

Remove the cover (22) by unscrewing the nuts (11) and remove the seal (106).

Remove the exhaust deflector (162) by unscrewing the bolt (9).

Remove the clip (173) and pull out the float valve (172).

Take off the gasket, clean the nozzle, check the tightness of the float valve.

Check the gaskets of the float-valve and replace them if required.

Reassemble the float-valve in reverse sequence.

Tighten the demister support units (165) and the exhaust deflector (162). If necessary mount a new seal (106) and mount the cover (22).

I. Replacing the exhaust valves

Required tools: Tubular box wrench SW16.

Remove the hood (48) by unscrewing the screws (26).

Remove the rubber mounts (44) and the screws (9).

Remove the cover (22) and the gasket (106).

By removing the nuts (11), it is possible to dismount the valve stop and valve plates (107, 108 & 109).

Replace these elements if required.

Reassemble the valve stop and valve plates (107, 108 & 109) in reverse sequence.

J. Replacing the pump module

Fully assembled pump modules are available under Ref. Nos. :
SV630 B / SV 630 BF: 9 714 37 330, SV 750 B: 9 714 37 330
Consult Leybold.

K. Disassembling and reassembling the pump module

Consult Leybold.

Maintenance

L. Checking and tightening the V-belts

Tools required : Key 19 and 24.

Take off the hood (55 or 15).

Loosen the nuts (66) and (23) x 2. Loosen the push rod (82).

Remove the V belts.

Reassemble in reverse sequence.

Stretch the V-Belts with the following method:

V-belt tension meter

This tension meter ref. 971437840 is a tool designed to check and re-tighten the v-belts

It is made of two sliding pipes with a graded spring inside.

How to use this v-belt tension meter :

- Set the first o-ring at 10 mm (PIX) on the millimeter scale or 25 Inches of Span (Goodyear), as shown figure 8, picture 3, and the other o-ring on position 0 on the Newton scale.
- Install the tension meter as shown on picture 1 – figure 8, in the middle, half-way between the v-belt contacts point of the v-belts and the two pulleys.
- Push the Newton scale's black rubber down in order to reach a 10 mm bending of the v-belt (pictures 2 and 4).

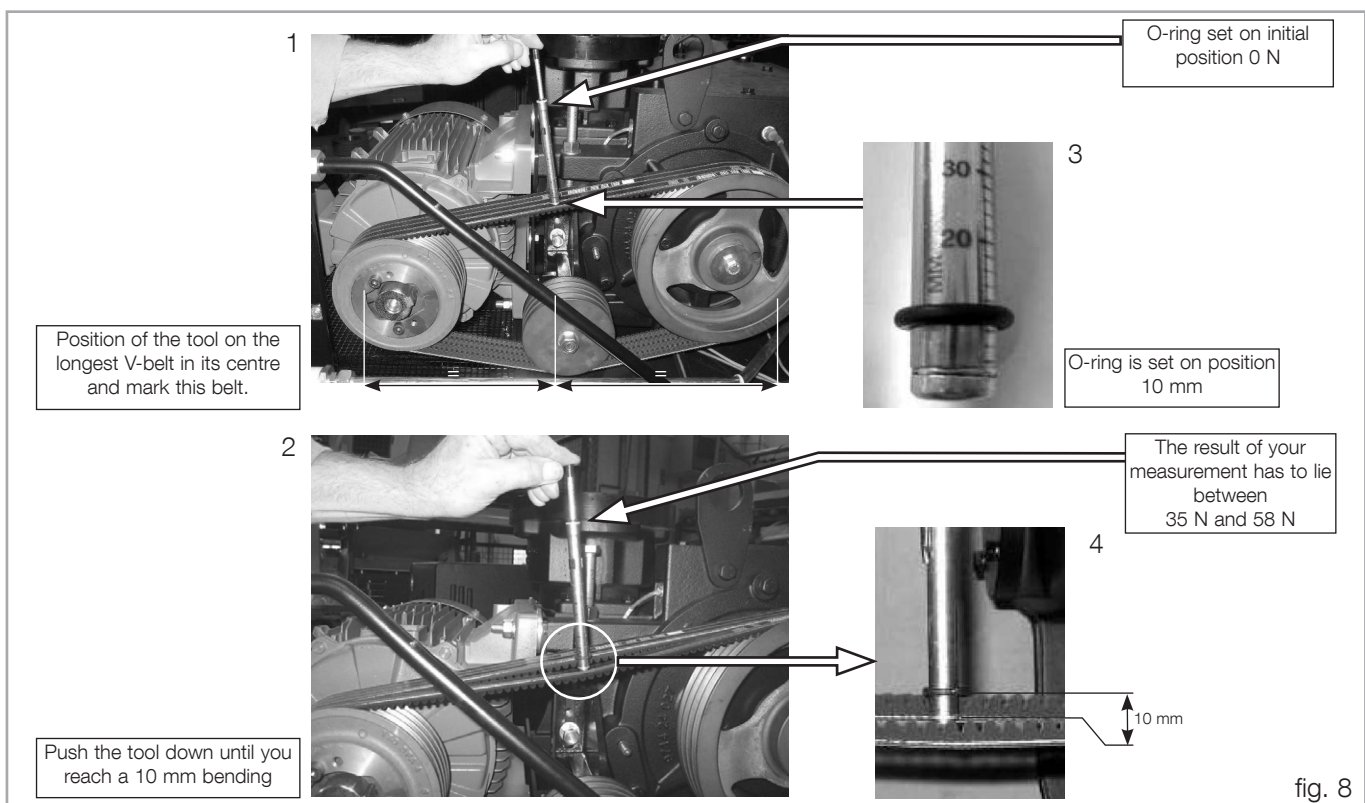

- Check the result of your measurement. Tighten the belt tightener to reach the value given in table below.

Tension values with Goodyear tensionmeter

Pump	Belts L (mm)	Pin	Before run-in	Re-tightening (after 10 to 24 h) (1)	Regular check (≈6 months or 3000 h.) Value under which a re-tension is necessary. *
			Force F (kg)	Force F (kg)	Force F (kg)
SV630 B (F)	1500	9 714 30 590	5,0	4,5	3,5
SV630 B USA/JPN	1532	9 714 37 640	5,0	4,5	3,5
SV750 B (F)	1582	9 714 33 170	5,0	4,5	3,5

* Re-tighten with values given in column (1)

Measure always on the same belt.

CAUTION : Do no untighten a belt if the measurement is over the value in column (1). Do not change the V-belt tension.

Tension values with PIX tensionmeter

Pump	Belts L (mm)	Pin	Before run-in	Re-tightening (after 10 to 24 h) (1)	Regular check (≈6 months or 3000 h.) Value under which a re-tension is necessary. *
			Force F (N)	Force F (N)	Force F (N)
SV630 B (F)	1500	9 714 30 590	50	45	35
SV630 B USA/JPN	1532	9 714 37 640	50	45	35
SV750 B (F)	1582	9 714 33 170	50	45	35

* Re-tighten with values given in column (1)

Measure always on the same belt.

CAUTION : Do no untighten a belt if the measurement is over the value in column (1). Do not change the V-belt tension.

Maintenance

M. Lubricating the bearings

The SOGEVAC® are equipped with separate grease-lubricated bearings. In normal operation the permanent-lubricated bearings are provided for 30 000 hours of maintenance-free operation.

With increased thermal load, i. e. continuous operation at high intake pressures, gas ballast operation, it is advisable to check the bearings at shorter intervals. To do so, remove the rear and front covers (97 and 136).

Test the bearing grease. If the grease is degraded, clean the bearings and change the grease.

Use special Leybold high temperature grease included in the Leybold repair kits and sets.

Grease quantity per bearing :

Bearing (94)	14 cm ³ or 12 g
Bearing (139)	20 cm ³ or 18 g

The motor bearings must be changed every 20 000 h.

Please check the instruction manual of the motor, also available on Internet. Clean the motor and remove its condensate plugs once a year at least;

For all maintenance works, use only genuine Leybold parts !

If non genuine Leybold parts are used during warranty period, we reserve the right to reject any claim.

Troubleshooting

6 Troubleshooting

Fault	Possible cause	Remedy	Reference section *
Pump does not start.	Pump is connected incorrectly.	Connect the pump correctly.	3.3
	Motor protection switch incorrectly set.	Set motor protection switch properly.	3.3
	Operating voltage does not match motor.	Replace the motor.	
	Motor is malfunctioning.	Replace the motor.	
	Oil temperature is below 12°C (54°F).	Heat the pump and pump oil or use different oil.	1.8
	Oil is too viscous.	Use appropriate oil grade.	5.4-C
	Exhaust filter / exhaust line is clogged.	Replace the filter or clean the exhaust line.	3.4-D
Pump does not reach ultimate pressure.	Power transmission by V-belts is impaired.	Tighten or replace the V-belts.	5.4-L
	Pump is seized up	Repair the pump.	5.4-M
	Measuring technique or gauge is unsuitable.	Use correct measuring technique and gauge.	4.3
	External leak	Repair the pump.	
	Float valve does not close.	Repair the valve.	5.4-I
	Anti-suckback valve is malfunctioning.	Repair the valve.	5.4-F
	Inadequate lubrication due to:		
■ unsuitable or contaminated oil,	Change the oil (degas it, if necessary).	5.4-C	
■ clogged oil filter,	Replace the oil filter.	5.4-C	
■ clogged oil lines.	Clean the oil casing.		
Vacuum lines are dirty.	Clean vacuum lines.		
Pump is too small.	Check the process date; replace the pump, if necessary.		
Pumping speed is too low.	Dirt trap in the intake port is clogged.	Clean the dirt trap ; Precaution : install a dust filter in intake line.	5.4-E/1.2/3.2
	Exhaust filter is clogged.	Install new filter elements.	5.4-D
	Connecting lines are too narrow or too long.	Use adequately wide and short connecting lines.	3.2
	Anti-suckback valve is hard to open.	Check spring free length.	
After switching off pump under vacuum, pressure in system rises too fast.	System has a leak.	Check the system.	
	Anti-suckback is malfunctioning.	Repair the valve.	5.4-F
Pump gets too hot	Cooling air supply is obstructed.	Set pump up correctly.	3.1
	Cooler is dirty.	Clean the cooler.	
	Ambient temperature is too high.	Set pump up correctly.	3.1
	Process gas is too hot.	Change the process.	
	Oil level is too low.	Add oil to reach the correct oil level.	5.4-C
	Oil is unsuitable.	Change the oil.	5.4-C
	Oil cycle is obstructed.	Clean or repair the oil lines.	
	Exhaust filter / exhaust line is obstructed.	Replace the exhaust filter, clean the exhaust line.	5.4-D
Pump module is no longer usable.	Replace the pump module.	5.4-K	

Troubleshooting

Fault	Possible cause	Remedy	Reference section *
Oil in intake line or in vacuum vessel.	Oil comes from the vacuum system.	Check the vacuum system.	
	Anti-suckback valve is obstructed.	Clean or repair the valve.	5.4-F
	Sealing surfaces of anti-suckback valve are damaged or dirty.	Clean or repair the intake port and valve.	5.4-F
	Oil level is too high.	Drain the excess oil.	5.4-C
Pump's oil consumption too high, oil mist at exhaust.	Exhaust filters are clogged or damaged.	Replace the filters.	5.4-D
	Nozzle of float valve is clogged.	Check the valve, clean the nozzle.	5.4-I
	Oil level is too high.	Drain the excess oil.	5.4-C
Oil is turbid.	Condensation.	Degas the oil or change the oil and clean the pump.	4.1/5.4-B
		Precaution : open the gas ballast valve or insert a condensate trap.	
		Clean the gas ballast intake filter.	5.4-G
Pump is excessively noisy.	Oil level is very low (oil is no longer visible).	Add oil.	5.4-C
	Oil filter is clogged.	Change the oil and filter.	5.4-C
	Large vacuum leak in system.	Repair vacuum leak.	5.4-L
	Power transmission by V-belts is impaired.	Tighten or replace the V-belts.	5.4-M

* Reference section : This column refers to the section in the Operating Instructions that contains the applicable repair information.

Never mount used seals. Always mount new seals.

7 Spare parts

To guarantee safe operation of the Leybold vacuum pump, only original spare parts and accessories should be used. When ordering spare parts and accessories, always state pump type and serial number. You can find part numbers in the spare parts list.

Consummables and main spare parts kits for SOGEVAC® pumps are usually available on stock at Leybold's service centers. The list of these parts is given here after and in the spare parts table where the contents of each kits is detailed.

- Oil filter (on some models)
- Exhaust demisters
- Oil (Special oils please refer to the specific notice of the pump or contact Leybold).
- Service kit
- Set of seals
- Repair kit

We recommend to use these kits which have been defined to allow an optimal maintenance or repair. individual spare parts may need longer delivery time.

For all maintenance works, use only genuine Leybold parts !
If non genuine Leybold parts are used during warranty period, we reserve the right to reject any claim.

Spare parts

Pos.	Qty	SPECIFICATION	Dimensions (mm), Material	Ref, No,	Notes	971437310	960863	960867	971437320	971437330	971437340
1	1	OIL CASING		971424050			●	●			
2	14	NUT	Q6				●	●			
3	32	WASHER					●	●	●		
4	1	O-RING	FKM			●	●				●
5	1	PLUG	G3/4	71256380			●				
6	1	BASE FRAME		971430740			●				
	1	SET OF RUBBER FEET	DN100	71403350			●	●			
7	26	SCREW	Q8.8				●	●	●		
8	3	WASHER					●	●			
9	51	SCREW	Q6.8				●	●			
10	35	WASHER					●	●			
11	47	NUT	Q6				●	●			
12	87	WASHER					●	●			
13	1	COVER UNDER OIL CASING		971425750			●	●			
14	2	O-RING	FKM			●	●	●			
15	1	FRONT HOOD AIR COOL		971432390			●				
16	1	OIL PIPE COOLER OIL CASING		971434740			●				
17	1	OIL TUBE COOLER STATOR		971434730			●				
18	1	V-BELT (SET OF 4)	LG1500	971430590	SV630 B / BF		●	●			
18	1	V-BELT (SET OF 4)	LG1532	971437640	SV630 B US / JIS						
18	1	V-BELT (SET OF 4)	LG1582	971433170	SV750 B						
19	2	DISC FOR ROTOR	D59	71249660			●	●	●		
20	1	V-BELT PULLEY	DN250	971431890			●	●			
21	1	GENERATOR VACUUM GB		971439030			●	●		●	
22	3	COVER FRONT OIL CASING		971425270			●	●			
24	1	UNIT STRETCHER		971424070			●	●			
24a	1	BALL BEARING (SET OF 2)					●	●	●		
25	18	SCREW	Q8.8				●	●			
26	12	SCREW	Q8.8				●	●			
27	1	OIL COOLER		971432800			●				
28	1	OIL COOLER BASE		971425110			●				
29	4	SCREW	Q6.8				●	●			
30	2	WASHER					●				
31	1	FAN	D350	971431620			●				
32	2	SCREW	Q8.8				●				
33	1	ADAPTOR VENTILATOR		71249280	SV630 B EUR		●				
33	1	ADAPTOR VENTILATOR		71249570	SV630 B / BF US						
33	1	ADAPTOR VENTILATOR		71249560	SV750 B EUR						
33	1	ADAPTOR VENTILATOR		71249490	SV630 B JIS						
34	1	PULLEY UNIT		971465330	SV630 B EUR		●				
34	1	PULLEY UNIT		EK71415758	SV630 BF EUR			●			
34	1	PULLEY UNIT		971465340	SV630 B / BF US						
34	1	PULLEY UNIT		971465360	SV750 B EUR						
34	1	PULLEY UNIT		EK971433168	SV750 BF EUR						
34	1	PULLEY UNIT		971465350	SV630 B JIS						
35	1	HUB		Incl. in 34			●	●			

Spare parts

Pos.	Qty	SPECIFICATION	Dimensions (mm), Material	Ref, No,	Notes	971437310	960863	960867	971437320	971437330	971437340
36	6	WASHER					●	●			
37	4	NUT	Q6				●	●			
38	1	MOTOR	15KW	71405020	SV630 B/F EURO		●	●			
38	1	MOTOR	25HP	71408560	SV630 B/F US						
38	1	MOTOR	18.5KW	71405200	SV750 B/F EUR						
38	1	MOTOR	18.5KW	71251610	SV630 B/F JIS						
38	1	WIDE RANGE MOTOR	18.5KW	E971472058	SV630 B/F						
39	1	PIN (x10)	Q8.8	971434010			●	●			
40	2	SCREW	Q6.8				●	●			
41	2	WASHER	NFE25513-A1K				●	●			
42	1	INTAKE FLANGE 100ISOK	100ISOK	971430550			●				
43	1	COLLAR FLANGE	100PN10-100ISO-K	71118383			●				
44	10	RUBBER MOUNT	D40 H20	71010280			●	●			
45	1	PLATE CONN BOX		71403670			●	●			
46	1	HOOD (UPPER)		971432510			●	●			
47	1	PLUG		971434020			●	●			
48	1	HOOD		971432420			●	●			
49	1	HOOD REAR		971432410			●	●			
50	1	NIPPLE	R3/4	71255330				●			
51	1	VALVE	G3/4 DN20	71235740				●			
52	1	BASE FRAME		971432330				●			
53	1	PROTECTION ACCESSORIES		971434560				●			
54	1	COVER		971433490				●			
55	1	HOOD FRONT WATER		971432400				●			
56	1	WATER INLET FLEXIBLE		971466880				●			
57	1	FLAT GASKET (SET OF 4)				●		●			
58	1	WATER OUTLET FLEXIBLE		971466860				●			
59	1	OIL TUBE EXCH STATOR		971434770				●			
60	1	OIL TUBE EXCH OIL CASING		971434760				●			
61	1	THERMOSTATIC VALVE		71232450				●			
62	1	ELECTRICAL BOX		71405150				●			
63	1	HEAT EXCHANGER		971426690				●			
64	8	PIN	Q6.8					●			
65	18	WASHER					●	●			
66	18	NUT	Q6				●	●			
67	1	ROOTSADAPTER 2000		971432350				●			
68	1	O-RING				●		●			
69	1	EXHAUST FLANGE	100 ISO K	971425260				●			
70	1	O-RING	89			●		●			
72	19	SCREW	Q6.8				●	●			
73	20	NUT					●	●			
75	1	O-RING				●	●	●			
80	1	STATOR		971424000			●	●			
81	4	CONNECTION		71405810			●	●			
82	1	PUSH ROD		971430580			●	●			
84	1	MOTOR SUPPORT		971424980			●	●			
85	1	MOTOR SUPPORT		971424970			●	●			
86	2	SCREW	Q6.8				●	●			

Spare parts

Pos.	Qty	SPECIFICATION	Dimensions (mm), Material	Ref, No,	Notes	971437310	960863	960867	971437320	971437330	971437340
87	1	KEY		71077560			●	●			
88	1	SET OF VANE (3)		971424540			●	●	●		
89	1	ROTOR		971424480			●	●			
90	7	O-RING	FKM			●	●	●			
91	2	O-RING	FKM			●	●	●			
92	1	RACE BUSHING	50	971425950			●	●	●		
93	1	FRONT END PLATE		971424010			●	●			
94	1	BALL BEARING C3	D100				●	●	●		
95	1	SPRING RING					●	●	●		
96	2	O-RING	FKM			●	●	●			
97	1	FRONT COVER		971425980			●	●			
98	2	SHAFT SEAL (SET)				●	●	●			
100	2	LIFTING LUG		971432640			●	●			
101	1	INLET FLANGE	Used until S/N 31000813670	971423990							
103	1	ANTISUCKBACK VALVE				●	●	●			
105	1	SPRING		971425990	SV630 B		●		●		
106	2	O-RING	FKM			●	●	●			
107	4	VALVE STOP		971425920			●	●	●		
108	2	VALVE PLATE		971425900			●	●	●		
109	2	VALVE PLATE		971425910			●	●	●		
110	26	PIN	Q6.8				●	●			
111	2	PIN	Q6.8				●	●			
112	1	THERMALSWITCH		971430630			●				
112	1	THERMALSWITCH		971440000				●			
116	1	O-RING	FKM			●	●	●			
118	2	O-RING	FKM			●	●	●			
119	1	GAS BALLAST VALVE		971426060			●				
120	1	O-RING	FKM			●	●				
121	1	O-RING	FKM			●	●				
122	1	PLUG	G1	71073040			●	●			
123	2	O-RING	FKM			●	●	●			●
124	1	GAS BALLAST		971446490			●				
124	1	GAS BALLAST		971438170				●			
127	1	PAPER FILTER		71040760			●	●	●	●	
130	1	GAS BALLAST MEMBRANE				●	●	●			
131	1	O-RING	FKM			●	●	●			
134	2	TAPERED PIN		971430520			●	●			
135	1	SCREW		971424710			●				
136	1	REAR END PLATE		971425940			●	●			
137	1	RACE BUSHING					●	●			
138	1	SPRING RING					●	●	●		
139	1	BALL BEARING	D120				●	●	●		
140	2	TAPERED PIN					●	●			
141	1	REAR END PLATE		971424020			●				
141	1	REAR END PLATE		971424420				●			
142	1	RACE BUSHING	D50				●	●	●		
143	1	PIN	Q6.8				●	●			
144	1	OIL TUBE		971433480				●			
145	1	E.M. VALVE	G1/4 24VDC	71405860				●			

Spare parts

Pos.	Qty	SPECIFICATION	Dimensions (mm), Material	Ref, No,	Notes	971437310	960863	960867	971437320	971437330	971437340
146	1	NIPPLE	R1/4					●			
146	2	PLUG	R1/4				●				
147	1	REDUCER SEAL	3/4F - 1/2M	971438900				●			
148	1	EM VALVE	G1/2 24VDC	71405870				●			
149	1	CONNECTION ELEMENT	DN18	971430990				●			
150	1	OIL HOLD BACK STEEL SHEET		971437760			●	●			
151	1	PLUG	1/2 BSP	71231810			●	●			
152	1	O-RING		FKM		●	●				
152	2	O-RING		FKM		●		●			
160	1	OIL CASING		971424040			●	●			
161	2	PLUG	G3/8	71402700			●	●			
162	1	EXHAUST DEFLECTOR		971425210			●	●			
164	1	OIL LEVEL GLASS		71029600			●	●	●		
165	2	DEMISTER SUPPORT UNIT		971425130			●	●			
166	8	SPRING		71436210			●	●			●
167	8	EXHAUST CARTRIDGE BY PASS		971431120			●	●	●	●	●
168	1	OIL FILTER		71405310			●	●	●	●	●
172	1	FLOAT VALVE.		71417210			●	●	●		
172 a	1	O-RING		FKM		●	●	●			
172 b	1	OIL RETURN VALVE SEAL				●	●	●			
173	1	CLIP		971425870			●	●	●		
174	1	COVER		971425860			●	●			
175	1	O-RING		FKM		●	●	●			
176	1	O-RING		FKM		●	●	●			
177	1	COVER		971425710			●	●			
178	1	O-RING		FKM		●	●	●			
179	4	PIN	Q8.8	971443750			●	●			
		SET OF SEALS		971437310		↑			●	●	
		SOGEVAC AIR-COOLED	SV630 B / SV750 B	960863		↑	↑	↑	↑	↑	↑
		SOGEVAC WATER-COOLED	SV630 BF	960867		↑	↑	↑	↑	↑	↑
		REPAIR KIT		971437320		↑	↑	↑	↑	↑	↑
		MODULE KIT		971437330		↑	↑	↑	↑	↑	↑
		SERVICE KIT		971437340		↑	↑	↑	↑	↑	↑

* For every order, please indicate the brand and the serial number of motor and of the pump.

Spare parts

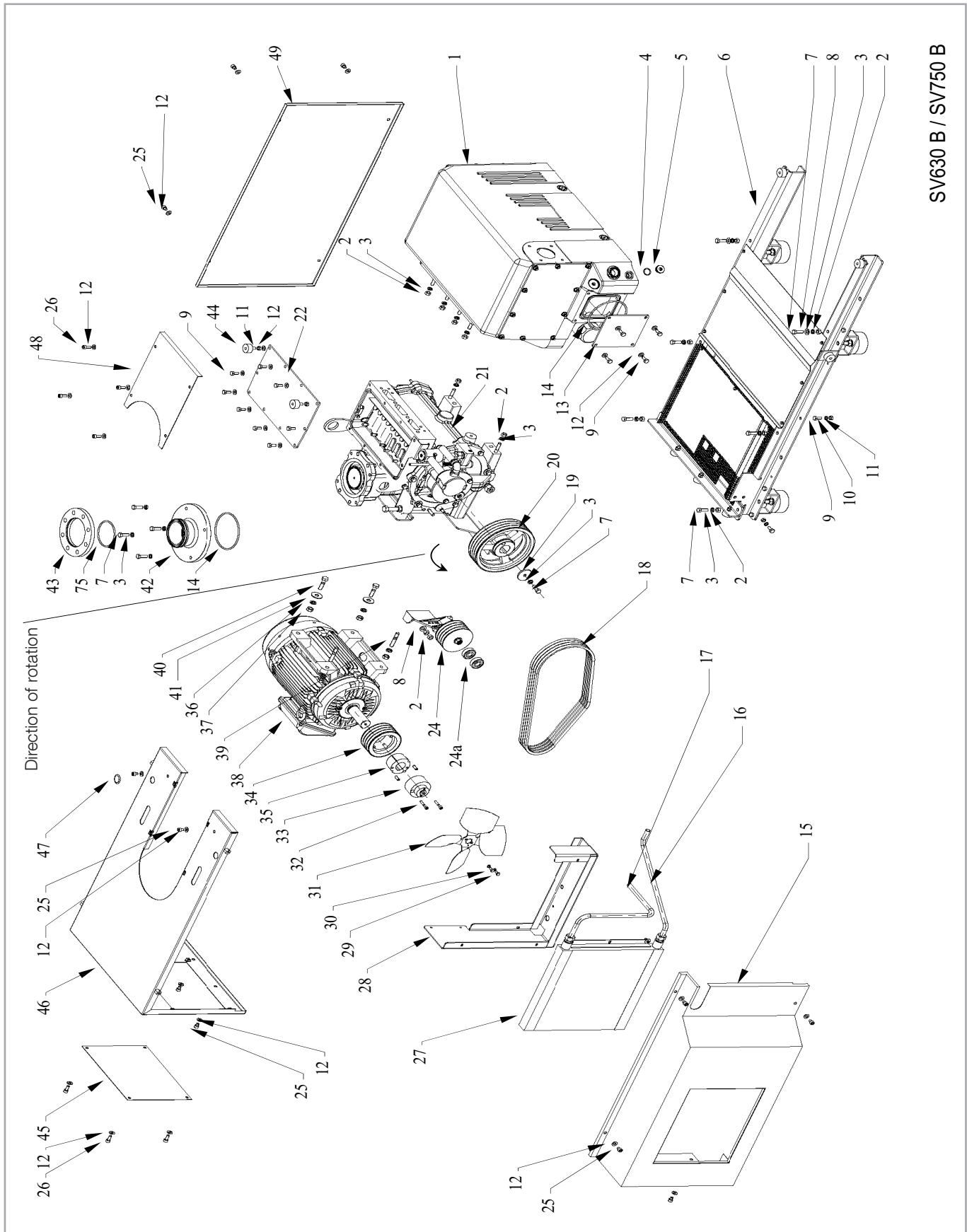

SV630 B / SV750 B

Spare parts

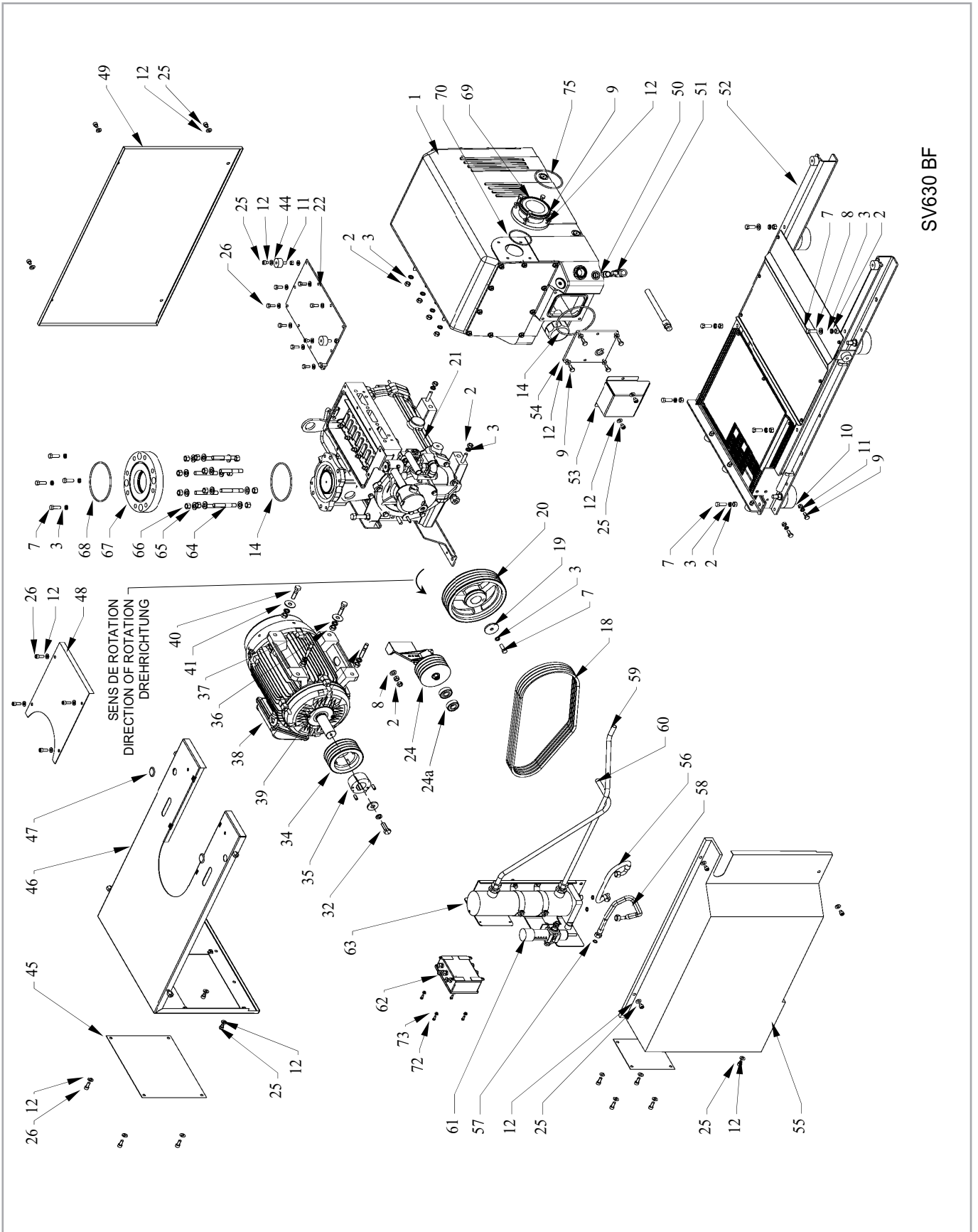

Spare parts

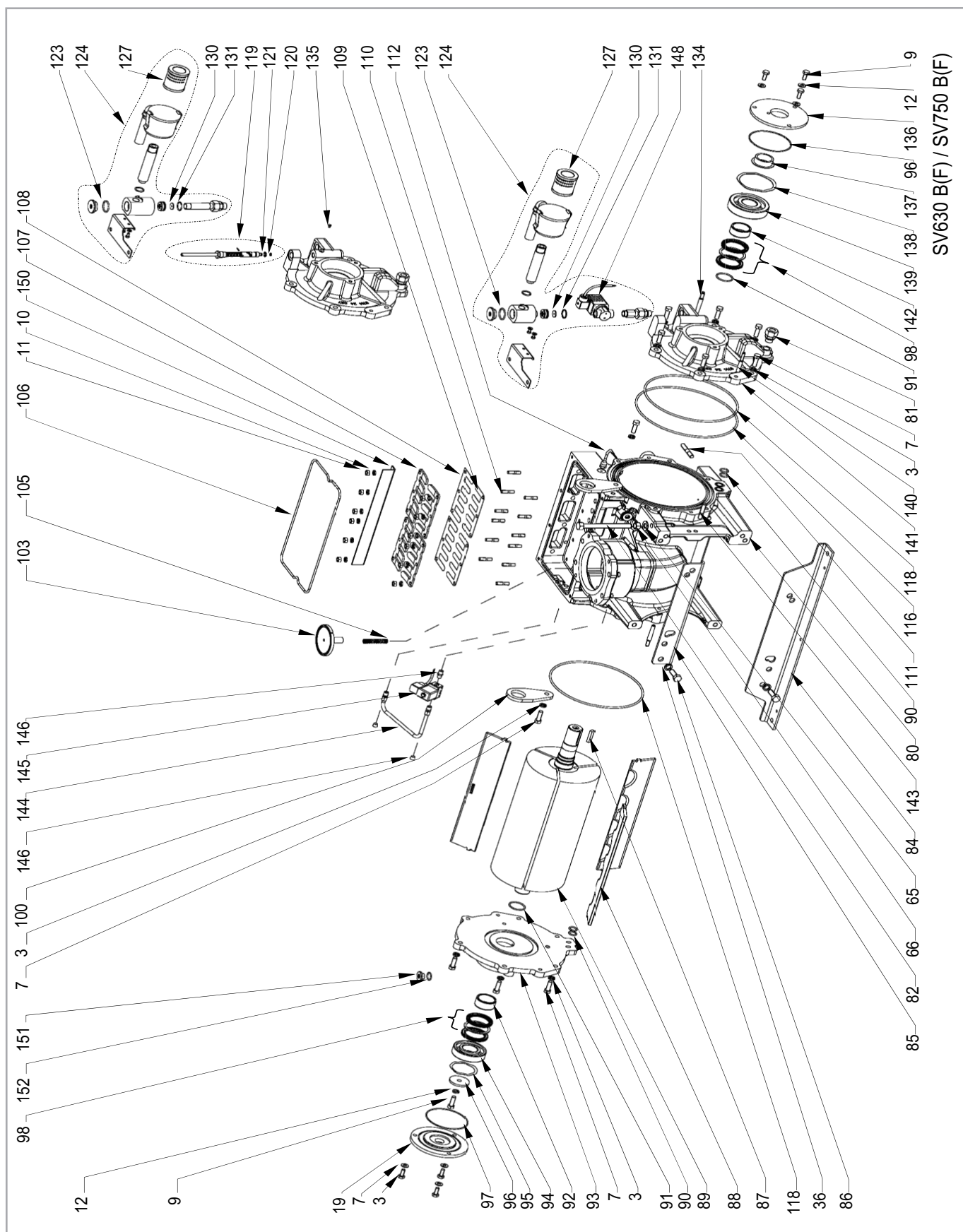

SV630 B(F) / SV750 B(F)

Spare parts

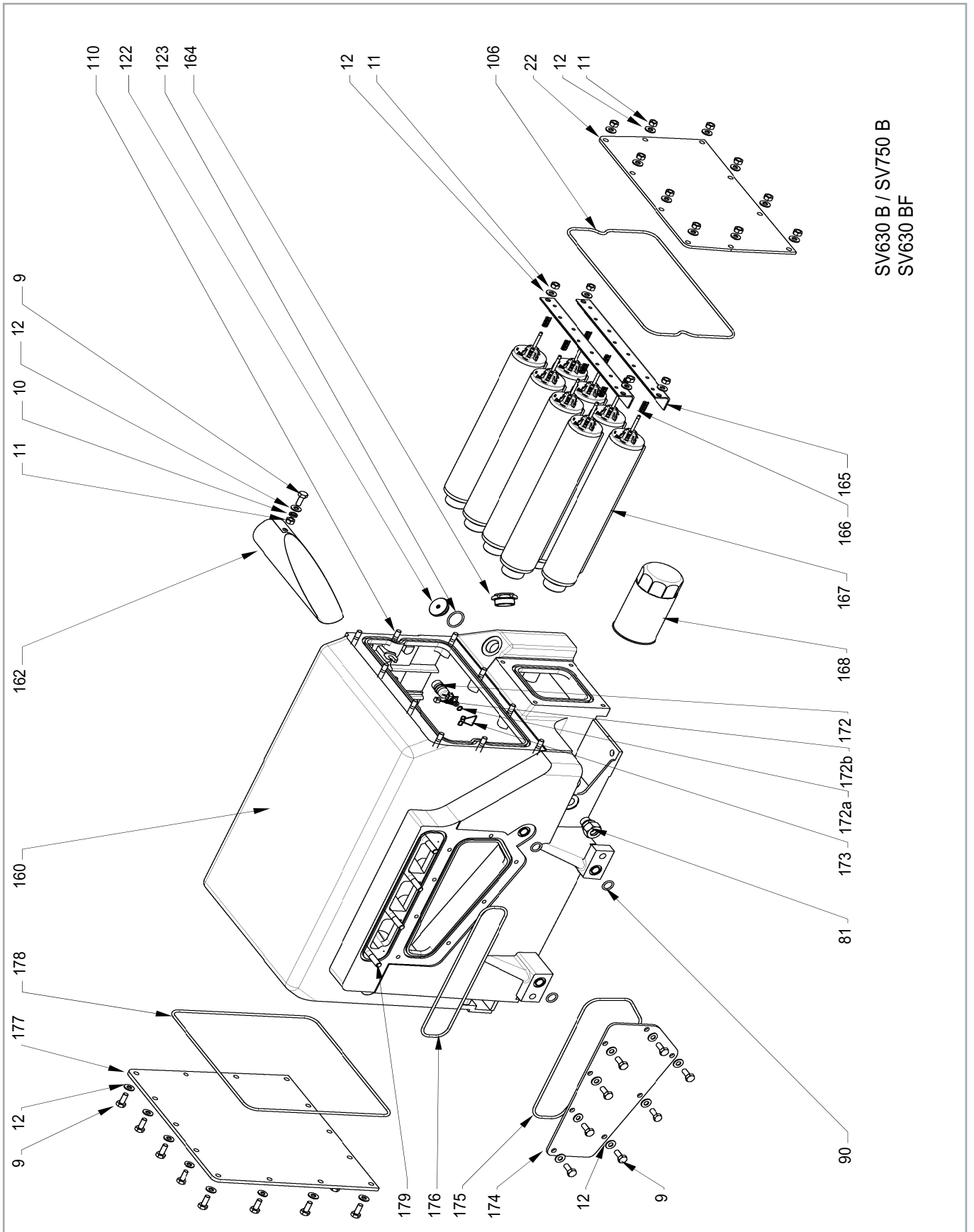

SV630 B / SV750 B
SV630 BF

Disposal

Contamination

WARNING



8 Waste Disposal

The equipment may have been contaminated by the process or by environmental influences. In this case the equipment must be decontaminated in accordance with the relevant regulations. We offer this service at fixed prices. Further details are available on request.

Contaminated parts can be detrimental to health and environment. Before beginning with any work, first find out whether any parts are contaminated. Adhere to the relevant regulations and take the necessary precautions when handling contaminated parts.

Separate clean components according to their materials, and dispose of these accordingly. We offer this service. Further details are available on request.

When sending us any equipment, observe the regulations given in Section "5.3 Leybold service".

Disposal of Waste Oil

Owners of waste oil are entirely self-responsible for proper disposal of this waste.

Waste oil from vacuum pumps must not be mixed with other substances or materials.

Waste oil from vacuum pumps (Leybold oils which are based on mineral oils) which are subject to normal wear and which are contaminated due to the influence of oxygen in the air, high temperatures or mechanical wear must be disposed of through the locally available waste oil disposal system.

Waste oil from vacuum pumps which is contaminated with other substances must be marked and stored in such a way that the type of contamination is apparent. This waste must be disposed of as special waste.

European, national and regional regulations concerning waste disposal need to be observed. Waste must only be transported and disposed of by an approved waste disposal vendor.

EU Declaration of Conformity

(Translation of original Declaration of Conformity)

The manufacturer: Leybold GmbH
Bonner Strasse 498
D-50968 Köln
Germany

herewith declares that the products specified and listed below which we have placed on the market, comply with the applicable EU Council Directives. This declaration becomes invalid if modifications are made to the product without agreement of Leybold GmbH.

Product designation: SOGEVAC
Type designation: SV16, SV25, SV16D, SV25D, SV200, SV1200, SV16B, SV25B, SV40B, SV65B, SV100B, SV120B (I FC), SV300B, SV470B, SV500B, SV570B, SV630B, SV750B, SV28BI (FC), SV40BI (FC), SV65BI (FC), and their variants, excepted pumps delivered without motor

The products complies to the following European Council Directives:

Machinery Directive (2006/42/EC)

The safety objectives of the Low Voltage Directive 2014/35/EU were complied with in accordance with Appendix 1 No. 1.5.1 of Machinery Directive 2006/42/EC.

Electromagnetic Compatibility (2014/30/EU)

RoHS Directive (2011/65/EU) & (2015/863/EU)

The following harmonized standards have been applied:

- | | |
|---------------------------|---|
| EN 1012-2:1996+A1:2009 | Compressors and vacuum pumps — Safety requirements — Part 2: Vacuum pumps |
| EN 60204-1:2006/A1:2009 | Safety of machinery — Electrical equipment of machines — Part 1: General requirements requirements |
| EN 61000-6-2:2005/AC:2005 | Electromagnetic compatibility (EMC) - Part 6-2: Generic standards - Immunity for industrial environments |
| EN 61000-6-4:2007/A1:2011 | Electromagnetic compatibility (EMC) - Part 6-4: Generic standards - Emission standard for industrial environments |

Documentation officer: Herbert Etges
T: +49(0)221 347 0
F: +49(0)221 347 1250
documentation@leybold.com

Cologne, November 14, 2016

Cologne, November 14, 2016



ppa. Martin Tollner
Head of Product Lines

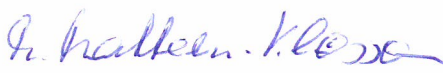

ppa. Dr. Monika Mattern-Klosson
Head of Quality & Business Process Management

Declaration of Contamination of Compressors, Vacuum Pumps and Components

The repair and / or servicing of compressors, vacuum pumps and components will be carried out only if a correctly completed declaration has been submitted. Non-completion will result in delay. The manufacturer can refuse to accept any equipment without a declaration.

A separate declaration has to be completed for each single component.

This declaration may be completed and signed only by authorized and qualified staff.

Customer/Dep./Institute : _____ Address : _____ _____ Person to contact: _____ Phone : _____ Fax: _____ End user: _____	Reason for return: <input checked="" type="checkbox"/> applicable please mark Repair: <input type="checkbox"/> chargeable <input type="checkbox"/> warranty Exchange: <input type="checkbox"/> chargeable <input type="checkbox"/> warranty <input type="checkbox"/> Exchange already arranged / received Return only: <input type="checkbox"/> rent <input type="checkbox"/> loan <input type="checkbox"/> for credit Calibration: <input type="checkbox"/> DKD <input type="checkbox"/> Factory-calibr. <input type="checkbox"/> Quality test certificate DIN 55350-18-4.2.1
--	--

A. Description of the Leybold product: Material description : _____ Catalog number: _____ Serial number: _____ Type of oil (ForeVacuum-Pumps) : _____	Failure description: _____ Additional parts: _____ Application-Tool: _____ Application- Process: _____
--	---

B. Condition of the equipment	No¹⁾	Yes	No	Contamination :	No¹⁾	Yes
1. Has the equipment been used	<input type="checkbox"/>	<input type="checkbox"/>	<input type="checkbox"/>	toxic	<input type="checkbox"/>	<input type="checkbox"/>
2. Drained (Product/service fluid)	<input type="checkbox"/>	<input type="checkbox"/>	<input type="checkbox"/>	corrosive	<input type="checkbox"/>	<input type="checkbox"/>
3. All openings sealed airtight	<input type="checkbox"/>	<input type="checkbox"/>	<input type="checkbox"/>	flammable	<input type="checkbox"/>	<input type="checkbox"/>
4. Purged	<input type="checkbox"/>	<input type="checkbox"/>	<input type="checkbox"/>	explosive ²⁾	<input type="checkbox"/>	<input type="checkbox"/>
If yes, which cleaning agent				radioactive ²⁾	<input type="checkbox"/>	<input type="checkbox"/>
and which method of cleaning				microbiological ²⁾	<input type="checkbox"/>	<input type="checkbox"/>
¹⁾ If answered with "No", go to D.				other harmful substances	<input type="checkbox"/>	<input type="checkbox"/>

C. Description of processed substances (Please fill in absolutely)

1. **What substances have come into contact with the equipment ?**
 Trade name and / or chemical term of service fluids and substances processed, properties of the substances
 According to safety data sheet (e.g. toxic, inflammable, corrosive, radioactive)

X	Tradename:	Chemical name:
a)		
b)		
c)		
d)		

2. Are these substances harmful ? No Yes

3. Dangerous decomposition products when heated ? No Yes

If yes, which ? _____

²⁾ Components contaminated by microbiological, explosive or radioactive products/substances will not be accepted without written evidence of decontamination.

D. Legally binding declaration

I / we hereby declare that the information supplied on this form is accurate and sufficient to judge any contamination level.

Name of authorized person (block letters) : _____ _____ Date	_____ signature of authorized person	<div style="border: 1px dashed black; height: 60px; width: 100%;"></div> firm stamp
--	---	---

Sales and Service

Germany

Leybold GmbH

Sales, Service, Support Center (3SC)
Bonner Strasse 498
D-50968 Cologne
T: +49-(0)221-347 1234
F: +49-(0)221-347 31234
sales@leybold.com
www.leybold.com

Leybold GmbH Sales Area North

Branch Office Berlin
Industriestrasse 10b
D-12099 Berlin
T: +49-(0)30-435 609 0
F: +49-(0)30-435 609 10
sales.bn@leybold.com

Leybold GmbH Sales Office South

Branch Office Munich
Karl-Hammerschmidt-Strasse 34
D-85609 Aschheim-Dornach
T: +49-(0)89-357 33 9-10
F: +49-(0)89-357 33 9-33
sales.mn@leybold.com
service.mn@leybold.com

Leybold Dresden GmbH Service Competence Center

Zur Wetterwarte 50, Haus 304
D-01109 Dresden
Service:
T: +49-(0)351-88 55 00
F: +49-(0)351-88 55 041
info.dr@leybold.com

Europe

Belgium

Leybold Nederland B.V. Belgisch bijkantoor

Leuvensesteenweg 542-9A
B-1930 Zaventem
Sales:
T: +32-2-711 00 83
F: +32-2-720 83 38
sales.zv@leybold.com
Service:
T: +32-2-711 00 82
F: +32-2-720 83 38
service.zv@leybold.com

France

Leybold France S.A.S.

Parc du Technopolis, Bâtiment Beta
3, Avenue du Canada
F-91940 Les Ulis cedex
Sales and Service:
T: +33-1-69 82 48 00
F: +33-1-69 07 57 38
info.ctb@leybold.com
sales.ctb@leybold.com

Leybold France S.A.S.

Valence Factory
640, Rue A. Bergès
B.P. 107
F-26501 Bourg-lès-Valence Cedex
T: +33-4-75 82 33 00
F: +33-4-75 82 92 69
marketing.vc@leybold.com

Great Britain

Leybold UK LTD.

Unit 9
Silverglade Business Park
Leatherhead Road
Chessington
Surrey (London)
KT9 2QL
Sales:
T: +44-13-7273 7300
F: +44-13-7273 7301
sales.ln@leybold.com
Service:
T: +44-13-7273 7320
F: +44-13-7273 7303
service.ln@leybold.com

Italy

Leybold Italia S.r.l.

Via Trasimeno 8
I-20128 Mailand
Sales:
T: +39-02-27 22 31
F: +39-02-27 20 96 41
sales.mi@leybold.com
Service:
T: +39-02-27 22 31
F: +39-02-27 22 32 17
service.mi@leybold.com

Netherlands

Leybold Nederland B.V.

Floridadreef 102
NL-3565 AM Utrecht
Sales and Service:
T: +31-(30) 242 63 30
F: +31-(30) 242 63 31
sales.ut@leybold.com
service.ut@leybold.com

Switzerland

Leybold Schweiz AG, Pfäffikon

Churerstrasse 120
CH-8808 Pfäffikon
Warehouse and shipping address:
Riedthofstrasse 214
CH-8105 Regensdorf
Sales:
T: +41-44-308 40 50
F: +41-44-302 43 73
sales.zh@leybold.com
Service:
T: +41-44-308 40 62
F: +41-44-308 40 60
service.zh@leybold.com

Spain

Leybold Spain, S.A.

C/. Huelva, 7
E-08940 Cornellà de Llobregat
(Barcelona)
Sales:
T: +34-93-666 43 11
F: +34-93-666 43 70
sales.ba@leybold.com
Service:
T: +34-93-666 46 11
F: +34-93-685 43 70
service.ba@leybold.com

America

USA

Leybold USA Inc.

5700 Mellon Road
USA-Export, PA 15632
T: +1-724-327-5700
F: +1-724-325-3577
info.ex@leybold.com
Sales:
T: +1-724-327-5700
F: +1-724-333-1217
Service:
T: +1-724-327-5700
F: +1-724-325-3577

Brazil

Leybold do Brasil

Rod. Vice-Prefeito Hermenegildo Tonolli,
nº. 4413 - 6B
Distrito Industrial
Jundiaí - SP
CEP 13.213-086
Sales and Service:
T: +55 11 3395 3180
F: +55 11 99467 5934
sales.ju@leybold.com
service.ju@leybold.com

Asia

P. R. China

Leybold (Tianjin) International Trade Co. Ltd.

Beichen Economic
Development Area (BEDA),
No. 8 Western Shuangchen Road
Tianjin 300400
China
Sales and Service:
T: +86-22-2697 0808
F: +86-22-2697 4061
F: +86-22-2697 2017
sales.tj@leybold.com
service.tj@leybold.com

India

Leybold India Pvt Ltd.

No. 82(F), 4th Phase
K.I.A.D.B. Plot
Bommasandra Industrial Area
Bangalore - 560 099
Indien
Sales and Service:
T: +91-80-2783 9925
F: +91-80-2783 9926
sales.bgl@leybold.com
service.bgl@leybold.com

Japan

Leybold Japan Co., Ltd.

Headquarters
Shin-Yokohama A.K.Bldg., 4th floor
3-23-3, Shin-Yokohama
Kohoku-ku, Yokohama-shi
Kanawaga 222-0033
Japan
Sales:
T: +81-45-471-3330
F: +81-45-471-3323
sales.yh@leybold.com

Leybold Japan Co., Ltd.

Tsukuba Technical Service Center
1959, Kami-yokoba
Tsukuba-shi, Ibaraki-shi 305-0854
Japan
Service:
T: +81-29 839 5480
F: +81-29 839 5485
service.iik@leybold.com

Malaysia

Leybold Malaysia

Leybold Singapore Pte Ltd.

No. 1 Jalan Hi-Tech 2/6
Kulim Hi-Tech Park
Kulim, Kedah Darul
Aman 09000
Malaysia
Sales and Service:
T: +604 4020 222
F: +604 4020 221
sales.ku@leybold.com
service.ku@leybold.com

South Korea

Leybold Korea Ltd.

3F. Jellzone 2 Tower
Jeongja-dong 159-4
Bundang-gu Sungnam-si
Gyeonggi-do
Bundang 463-384, Korea
Sales:
T: +82-31 785 1367
F: +82-31 785 1359
sales.bd@leybold.com
Service:
623-7, Upsung-Dong
Cheonan-Si
Chungcheongnam-Do
Korea 330-290
T: +82-41 589 3035
F: +82-41 588 0166
service.cn@leybold.com

Singapore

Leybold Singapore Pte Ltd.

8 Commonwealth Lane #01-01
Singapore 149555
Singapore
Sales and Service:
T: +65-6303 7030
F: +65-6773 0039
sales.sg@leybold.com
service.sg@leybold.com

Taiwan

Leybold Taiwan Ltd.

No 416-1, Sec. 3
Chunghsin Rd., Chutung
Hsinchu County 310
Taiwan, R.O.C.
Sales and Service:
T: +886-3-500 1688
F: +886-3-583 3999
sales.hc@leybold.com
service.hc@leybold.com

Headquarter

Leybold GmbH

Bonner Strasse 498
D-50968 Cologne
T: +49-(0)221-347-0
F: +49-(0)221-347-1250
info@leybold.com



www.leybold.com