

Operation and Service Manual

Scaling Amplifier

SIM983



Distribution in the UK & Ireland



Lambda Photometrics Limited
Lambda House Batford Mill
Harpenden Herts AL5 5BZ
United Kingdom

E: info@lambdaphoto.co.uk
W: www.lambdaphoto.co.uk
T: +44 (0)1582 764334
F: +44 (0)1582 712084

**Characterisation,
Measurement &
Analysis**

Revision 2.2 • August 28, 2006

Certification

Stanford Research Systems certifies that this product met its published specifications at the time of shipment.

Warranty

This Stanford Research Systems product is warranted against defects in materials and workmanship for a period of one (1) year from the date of shipment.

Service

For warranty service or repair, this product must be returned to a Stanford Research Systems authorized service facility. Contact Stanford Research Systems or an authorized representative before returning this product for repair.

Information in this document is subject to change without notice.

Copyright © Stanford Research Systems, Inc., 2005, 2006. All rights reserved.

Stanford Research Systems, Inc.
1290-D Reamwood Avenue
Sunnyvale, CA 94089 USA
Phone: (408) 744-9040 • Fax: (408) 744-9049
www.thinkSRS.com • e-mail: info@thinkSRS.com

Printed in U.S.A.

Document number 9-01598-903



SIM983 Scaling Amplifier

Contents

General Information	iii
Safety and Preparation for Use	iii
Symbols	iv
Notation	v
Specifications	vi
1 Getting Started	1 – 1
1.1 Introduction to the Instrument	1–2
1.2 Front-Panel Operation	1–3
1.3 Connections	1–5
1.4 Power-On	1–6
1.5 Restoring the Default Configuration	1–6
1.6 SIM Interface	1–7
2 Description of Operation	2 – 1
2.1 Signal Connections and Grounding	2–2
2.2 Autocalibration	2–2
2.3 AC Characteristics	2–3
2.4 Clock Stopping	2–4
3 Remote Operation	3 – 1
3.1 Index of Common Commands	3–2
3.2 Alphabetic List of Commands	3–4
3.3 Introduction	3–6
3.4 Commands	3–7
3.5 Status Model	3–19
4 Performance Verification	4 – 1
4.1 Verifying the DC Accuracy	4–2
4.2 Verifying AC Performance	4–4
4.3 Noise Characteristics	4–6
4.4 Performance Test Record	4–8
5 Circuit Description	5 – 1
5.1 Circuit Discussion	5–2
5.2 Parts List	5–6
5.3 Schematic Diagrams	5–10

A Index

A - 1

General Information

The SIM983 Scaling Amplifier, part of Stanford Research Systems' Small Instrumentation Modules family, performs the function

$$V_{\text{out}} = G \times (V_{\text{in}} + V_{\text{ofs}})$$

where V_{in} and V_{out} are voltages (up to ± 10 V) at the input and the output of the instrument, respectively, G is a user-specified gain, and V_{ofs} is a user-specified offset voltage. The instrument is accurate within its resolution.

Safety and Preparation for Use

The front-panel input, front-panel output, and the rear-panel output coaxial (BNC) connectors in the SIM983 are referenced to the Earth, and their outer casings are grounded. No dangerous voltages are generated by the module.











CAUTION

Do not exceed ± 15 volts to the Earth at the center terminal of each BNC connector. Do not install substitute parts or perform unauthorized modifications to this instrument.

The SIM983 is a single-wide module designed to be used inside the SIM900 Mainframe. Do not turn on the power to the mainframe or apply voltage input to the module until the module is completely inserted into the mainframe and locked in place.

Symbols you may Find on SRS Products

Symbol	Description
	Alternating current
	Caution - risk of electric shock
	Frame or chassis terminal
	Caution - refer to accompanying documents
	Earth (ground) terminal
	Battery
	Fuse
	On (supply)
	Off (supply)

Notation



WARNING

The following notation will be used throughout this manual:

A warning means that injury or death is possible if the instructions are not obeyed.



CAUTION

A caution means that damage to the instrument or other equipment is possible.

Typesetting conventions used in this manual are:

- Front-panel buttons are set as [gain ▲]; [gain ▲▼] is shorthand for “[gain ▲] & [gain ▼]”.
- Front-panel indicators are set as *OVLD*.
- Signal names are set as \neg STATUS.
- Signal levels are set as HIGH.
- Remote command names are set as *IDN?.
- Literal text other than command names is set as OFF.
- Special ASCII characters are set as <CR>.

Remote command examples will all be set in monospaced font. In these examples, data sent by the host computer to the SIM983 are set as *straight teletype font*, while responses received by the host computer from the SIM983 are set as *slanted teletype font*.

Specifications

Performance characteristics

		Min	Typ	Max	Units	
Input	Voltage [1]	-10.0		+10.0	V	
	Coupling	DC				
	Resistance	0.99	1.00	1.01	MΩ	
	Capacitance		26		pF	
	Bias current [2]			40	pA	
	Voltage noise [3, 4], 1 kHz			43		nV/√Hz
		10 kHz		38		nV/√Hz
	Current noise, 10 kHz		3		fA/√Hz	
	Terminals	Grounded BNC [5]				
	Gain	Absolute value	0.01		19.99	
Polarity		Inverting, non-inverting				
Resolution		0.01				
Accuracy [2]		±0.01				
Offset [3]	Stability			±10	ppm/°C	
	Voltage	-10.00		+10.00	V	
		Resolution, $ V_{\text{ofs}} \leq 1.999 \text{ V}$	1			mV
	$ V_{\text{ofs}} \geq 2.00 \text{ V}$	10			mV	
	Accuracy [2, 4, 6]	±1 ± 200			mV + ppm	
	Stability [4]			±20 ± 20	(μV + ppm)/°C	
	Settling time [7]			2	s	
AC performance	-3 dB bandwidth, $ G \leq 1.00$	2.0			MHz	
	Gain-bandwidth product, $ G \geq 1.00$	[8] $ G \geq 2.40$	3.0			MHz
		$ G \geq 2.40$	5.0			MHz
		$ G \geq 4.20$	10.0			MHz
		$ G \geq 9.60$	17.0			MHz
	Slew rate	70			V/μs	
THD, 1 kHz			-90	dB		
Output	Voltage [1]	-10.0		+10.0	V	
	Maximum current	±100			mA	
	Short circuit duration	Indefinite				
	Resistance		50		Ω	
Terminals	Grounded BNC, front [5] and rear [9]					
Operating	Temperature [10]	0		40	°C	
	Power	+5, ±15			V DC	
	Supply current, +5 V		100		mA	
		±15 V		300		mA

Conditions:

- [1] An overload will be detected and the instrument is not guaranteed to perform properly if these limits are exceeded, or if $|V_{in} + V_{ofs}|$ exceeds the limits. Continuous application of an input voltage V_{in} in excess of ± 15 V will damage the instrument.
- [2] At 23 °C.
- [3] Referred to input.
- [4] For $|G| \geq 1$. For $|G| < 1$, the specification applies to the output-referred noise and offset.
- [5] Amphenol 31-10-4052 or similar.
- [6] Following an autocalibration at (23 ± 5) °C within 24 hours; following a 2-hour warmup.
- [7] To within 0.1% of the final value.
- [8] The gain-bandwidth product (GBP) determines the -3 dB bandwidth:
For gain G , the bandwidth is $GBP/|G|$.
- [9] Tyco 227169-4 or similar.
- [10] Non-condensing.

General characteristics

Interface	Serial (RS-232) through SIM interface
Connectors	BNC (2 front [5], 1 rear [9]); DB-15 (male) SIM interface
Weight	1.5 lbs
Dimensions	1.5" W \times 3.6" H \times 7.0" D

1 Getting Started

This chapter gives you the necessary information to get started quickly with your SIM983 Scaling Amplifier.

In This Chapter

1.1	Introduction to the Instrument	1-2
1.1.1	Front and rear panels	1-3
1.2	Front-Panel Operation	1-3
1.2.1	Polarity	1-3
1.2.2	Gain	1-3
1.2.3	Offset	1-4
1.2.4	Overload	1-4
1.3	Connections	1-5
1.4	Power-On	1-6
1.5	Restoring the Default Configuration	1-6
1.6	SIM Interface	1-7
1.6.1	SIM interface connector	1-7
1.6.2	Direct interfacing	1-7

1.1 Introduction to the Instrument

remote interface The SIM983 Scaling Amplifier provides fine adjustable gain and offset control of an analog signal. The gain ($0.01 \leq |G| \leq 19.99$), its polarity (inverting or non-inverting), and the offset voltage ($-10.00 \text{ V} \leq V_{\text{ofs}} \leq +10.00 \text{ V}$) can be set from either the front panel or remotely. A remote computer can access the module through the SIM900 Mainframe, using RS-232 or GPIB.

DC accuracy The digital control circuitry in the SIM983 is designed with a special clock-stopping architecture. The microcontroller is turned on only when the polarity, gain, or offset are being changed, during remote communications, or when an overload condition occurs. This guarantees that no digital noise contaminates low-level analog signals. A user-commanded autocalibration procedure allows one to control the input-referred offset to within $\pm 1 \text{ mV}$ of the desired value.

AC performance The amplifier's high slew rate allows it to output a $\pm 10 \text{ V}$ peak-peak sine wave at a frequency of 1 MHz. The gain stage of the amplifier is compensated in a flexible fashion to provide a sensible pulse response, so the bandwidth of the instrument is adjusted according to its gain.¹ The ample output current in the SIM983 permits one to drive a 50Ω load.

If the maximum input voltage is exceeded, or the gain or offset cause the output voltage to exceed its maximum, the appropriate overload LED turns on. If armed, the module also generates a status signal to alert the user of the overload condition. The SIM983 can be operated outside the SIM900 Mainframe by powering it with its required DC voltages.

A block diagram of the amplifier is shown below in Figure 1.1.

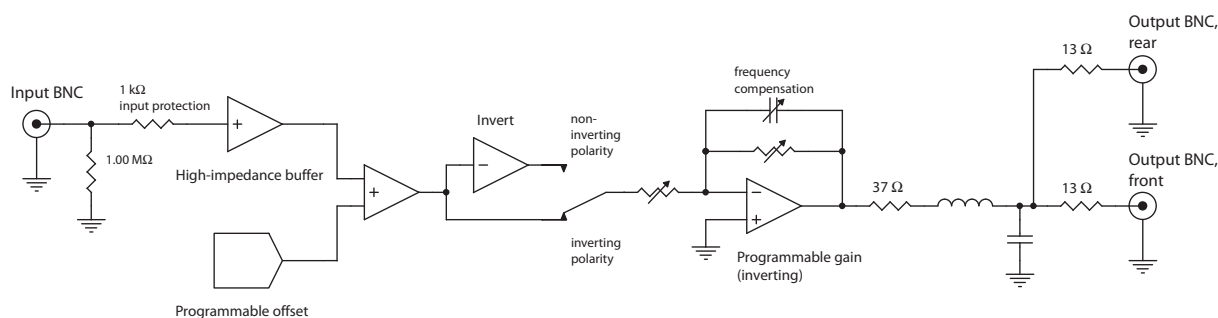

Figure 1.1: The SIM983 block diagram.

¹ The gain-bandwidth product changes with the gain.

1.1.1 Front and rear panels



Figure 1.2: The SIM983 front and rear panels.

1.2 Front-Panel Operation

1.2.1 Polarity

The polarity is the sign of the gain. It is indicated on the upper display of the front panel. To change the polarity, press the [polarity] button once. Holding this button has no effect.

Pressing [polarity] has no effect on the input-referred offset. However, a simultaneous press of [polarity] and one of [gain ▲▼] has a special meaning. This press initiates autocalibration (Section 2.2).

1.2.2 Gain

The gain G can be set to an absolute value between 0.01 and 19.99. To raise or lower the absolute value of the gain, press the button [gain ▲] or the button [gain ▼]. The decimal point position of the gain displayed on the front panel is fixed, so the resolution of the gain is 0.01. If [gain ▲] is pressed when the gain $G = \pm 19.99$, the press has no effect. If [gain ▼] is pressed when $G = \pm 0.01$, the press has no effect. Pressing either [gain ▲▼] does not change the polarity.

If one of [gain ▲▼] is pressed and held, the gain is continuously adjusted. The rate of the adjustment increases as the button is held. If the absolute value of the gain is being lowered, the rate of the adjustment changes as $|G|$ crosses 1.00, and possibly again as $|G|$ crosses 0.10.

resetting gain If *both* [gain ▲] and [gain ▼] buttons are pressed at the same time, the absolute value of the gain is reset to 1.00. This action does not change the polarity.

Pressing one of [gain ▲▼] and [polarity] at the same time has a special meaning. This press initiates autocalibration (Section 2.2).

1.2.3 Offset

The input-referred voltage offset V_{ofs} can be set to a value between -10.00 V and $+10.00\text{ V}$. Its value, in volts, is shown on the second line of displays on the front panel of the amplifier.

To increase or decrease the offset, press the button [offset ▲] or the button [offset ▼]. Unlike the gain, the “up” and “down” buttons adjust the offset, not its absolute value. Thus, for example, pressing [offset ▲] when $V_{\text{ofs}} = -5.49\text{ V}$ makes $V_{\text{ofs}} = -5.48\text{ V}$. If [offset ▲] is pressed when $V_{\text{ofs}} = +10.00\text{ V}$, the press has no effect. If [offset ▼] is pressed when $V_{\text{ofs}} = -10.00\text{ V}$, the press has no effect.

Between the values $-2.00\text{ V} < V_{\text{ofs}} < +2.00\text{ V}$, the offset is selected with 0.001 V resolution; the position of the decimal point on the front-panel displays is shifted to the left. Although the resolution is 0.01 V for $|V_{\text{ofs}}| \geq 2.00\text{ V}$, the accuracy of the offset is still $\pm 1\text{ mV} \pm 0.02\%$. Thus, for example, setting $V_{\text{ofs}} = -5.48\text{ V}$ produces $V_{\text{ofs}} = (-5.480 \pm 0.001 \pm 0.001) = (-5.480 \pm 0.002)\text{ V}$.

If one of [offset ▲▼] is pressed and held, the offset is continuously adjusted. The rate of the adjustment increases as the button is held. If the value crosses the threshold $V_{\text{ofs}} = \pm 2.00\text{ V}$, the rate changes appropriately.

resetting offset If *both* [offset ▲] and [offset ▼] buttons are pressed at the same time, the offset is reset to 0.000 V .

1.2.4 Overload

There are two overload indicators, one *OVL*D LED in the INPUT block and one *OVL*D LED in the OUTPUT block of the front panel. The overload signal can also be asserted on the $\overline{\text{STATUS}}$ pin. See Section 3.5.

1.2.4.1 Input overload

overload limits An overload condition is recognized and the input *OVL*D LED is activated if the absolute value of the voltage applied to the input exceeds certain limits. These limits are typically $\pm 10.0\text{ V}$, and are between

$$-10.4\text{ V} \leq V_{\min} \leq -9.9\text{ V}, \quad 9.9\text{ V} \leq V_{\max} \leq 10.4\text{ V}.$$

The overloaded state is also recognized, and the input overload LED activated, if the sum of the input voltage and the commanded offset, $|V_{\text{in}} + V_{\text{ofs}}|$, exceeds these limits. To distinguish between the two input overload possibilities, use the command *OVL*D?. The overload LED stays on for a minimum of 50 ms; after this time it turns off if the overload condition has ceased.

1.2.4.2 Output overload

An overload condition is recognized and the output *OVL*D LED is activated if the absolute value $|G \times (V_{\text{in}} + V_{\text{ofs}})|$ exceeds the limits in Section 1.2.4.1. The overload LED stays on for a minimum of 50 ms; after this time it turns off if the overload condition has ceased.

1.3 Connections

For a discussion of the front and rear BNC connections, see Section 2.1. The SIM interface connector is discussed in Section 1.6.1.

1.4 Power-On

The instrument retains the values of the gain and the offset in non-volatile memory. Upon power-on, those settings are restored to their values before the power was turned off.

The power-on configuration of the remote interface is detailed in Section 3.3.1.

1.5 Restoring the Default Configuration

The default configuration of the SIM983 is $G = +1.00$, $V_{\text{ofs}} = 0.000 \text{ V}$, and bandwidth \emptyset (see Section 2.3.1). This configuration is reached from the remote interface by issuing the `*RST` command. To reset only the gain or the offset to their default values, use button combinations described in Sections 1.2.2 or 1.2.3.

1.6 SIM Interface

The primary connection to the SIM983 Scaling Amplifier is the rear-panel DB–15 SIM interface connector. Typically, the SIM983 is mated to a SIM900 Mainframe via this connection, either through one of the internal mainframe slots or the remote cable interface.

It is also possible to operate the SIM983 directly, without using the SIM900 Mainframe. This section provides details on the interface.

1.6.1 SIM interface connector

The DB–15 SIM interface connector carries all the power and communication lines to the instrument. The connector signals are specified in Table 1.1.

Pin	Signal	Direction Src ⇒ Dest	Description
1	SIGNAL_GND	MF ⇒ SIM	Ground Reference 1
2	–STATUS	SIM ⇒ MF	Status/service request (GND = asserted, +5 V = idle)
3	RTS	MF ⇒ SIM	HW handshake (unused in SIM983)
4	CTS	SIM ⇒ MF	HW handshake (unused in SIM983)
5	–REF.10MHZ	MF ⇒ SIM	10 MHz reference (no connection in SIM983)
6	–5V	MF ⇒ SIM	Power supply (no connection in SIM983)
7	–15V	MF ⇒ SIM	Power supply
8	PS_RTN	MF ⇒ SIM	Ground Reference 2
9	CHASSIS_GND		Chassis ground
10	TXD	MF ⇒ SIM	Async data (start bit = “0” = +5 V; “1” = GND)
11	RXD	SIM ⇒ MF	Async data (start bit = “0” = +5 V; “1” = GND)
12	+REF.10MHZ	MF ⇒ SIM	10 MHz reference (no connection in SIM983)
13	+5V	MF ⇒ SIM	Power supply
14	+15V	MF ⇒ SIM	Power supply
15	+24V	MF ⇒ SIM	Power supply (no connection in SIM983)

Table 1.1: SIM interface connector pin assignments, DB–15.

1.6.2 Direct interfacing

The SIM983 is intended for operation in the SIM900 Mainframe, but users may wish to directly interface the module to their own systems without the use of additional hardware.

The mating connector needed is a standard DB–15 receptacle, such as Tyco part number 747909–2 (or equivalent). Clean, well-regulated supply voltages of ± 15.0 V DC, +5.0 V DC must be provided, following the pinout specified in Table 1.1 and the minimum currents in the table on Page vi. Ground must be provided on Pins 1 and 8, with chassis ground on Pin 9. The –STATUS signal may be monitored

on Pin 2 for a low-going TTL-compatible output indicating a status message. See Section 3.5 for the description of status messages.



CAUTION

The SIM983 has no internal protection against reverse polarity, missing supply, or overvoltage on the +5 V and the ± 15 V power-supply pins. Supply voltages above 5.5 V on Pin 13, above +16 V on Pin 14, or below -16 V on Pin 7 are likely to damage the instrument. SRS recommends using the SIM983 together with the SIM900 Mainframe for most applications.

1.6.2.1 Direct interface cabling

If the user intends to directly wire the SIM983 independent of the SIM900 Mainframe, communication is usually possible by directly connecting the appropriate interface lines from the SIM983 DB-15 plug to the RS-232 serial port of a personal computer.² Connect RXD from the SIM983 directly to RD on the PC, TXD directly to TD, and similarly RTS→RTS and CTS→CTS. In other words, a null-modem-style cable is *not* needed.

To interface directly to the DB-9 male (DTE) RS-232 port typically found on contemporary personal computers, a cable must be made with a female DB-15 socket to mate with the SIM983, and a female DB-9 socket to mate with the PC's serial port. Separate leads from the DB-15 need to go to the power supply, making what is sometimes know as a "hydra" cable. The pin connections are given in Table 1.2.

DB-15/F to SIM983	Name
	<u>DB-9/F</u>
10 \longleftrightarrow 3	TxD
11 \longleftrightarrow 2	RxD
5	Computer Ground
	<u>to Power Supply</u>
7 \longleftrightarrow -15 V DC	
13 \longleftrightarrow +5 V DC	
14 \longleftrightarrow +15 V DC	
1 \longleftrightarrow Ground 1 (separate wire to Ground)	
8 \longleftrightarrow Ground 2 (separate wire to Ground)	
9 \longleftrightarrow Chassis Ground (separate wire to Ground)	

Table 1.2: SIM983 direct interface cable pin assignments.

note about grounds The distinct Ground References 1 and 2, and the chassis ground, are *not* directly connected within the SIM983. Ground 1 carries the return

² Although the serial interface lines on the DB-15 do not satisfy the minimum voltage levels of the RS-232 standard, these lines are typically compatible with desktop personal computers.

currents of digital control signals and the power supplies, whereas the input voltage and the output voltage reference to Ground 2 (Section 2.1.2). When operating in the SIM900, the three grounds are tied together in the SIM900 Mainframe. Grounds 1 and 2 are connected through back-to-back Schottky diodes, so they cannot be more than $\sim \pm 0.35$ V apart. The three ground lines should be separately wired to a single, low-impedance ground source at the power supply.

1.6.2.2 Serial settings

The initial serial port settings at power-on are: baud rate 9600, 8 bits, no parity, 1 stop bit, and no flow control. The baud rate of the SIM983 cannot be changed. Flow control is not implemented in the SIM983. The parity may be changed with the `PAR1` command.

2 Description of Operation

This chapter provides a number of additional details of the operation of the SIM983.

In This Chapter

2.1	Signal Connections and Grounding	2-2
2.1.1	Output drive	2-2
2.1.2	Grounds	2-2
2.2	Autocalibration	2-2
2.3	AC Characteristics	2-3
2.3.1	Bandwidth	2-3
2.3.2	Slew rate	2-3
2.4	Clock Stopping	2-4

2.1 Signal Connections and Grounding

2.1.1 Output drive

The output impedance of the SIM983 Scaling Amplifier is $50\ \Omega$. The amplifier can drive load impedances from ∞ to $50\ \Omega$ for the full $\pm 10\ \text{V}$ range of output voltage. When driving a $50\ \Omega$ load, the gain will be half of that displayed on the front panel.

The rear-panel output connector is wired in parallel with the front-panel output, and shares some of the output impedance (Figure 1.1). The output stage is not designed to drive two $50\ \Omega$ loads simultaneously.

2.1.2 Grounds

Both the input and the output of the SIM983 are referenced to ground. To maintain the DC accuracy of the instrument, there are two separate ground references. Ground 1 (Pin 1 of the SIM interface connector) provides a return path for digital control signals and the power supply currents, while Ground 2 (Pin 8 of the interface connector) serves as the reference point for analog voltages. The outer casings of the input and the output front-panel BNC connectors are tied to Ground 2. The output current of the amplifier returns to the power supply through Ground 2.

The outer casing of the rear-panel output BNC is connected to chassis ground, Pin 9 of the DB-15 SIM interface connector. The separate power, analog, and chassis grounds are *not* directly connected within the amplifier. When operating in the SIM900 Mainframe, the three grounds are tied together inside the mainframe, and through the mainframe to the Earth. Grounds 1 and 2 are connected inside the SIM983 through back-to-back Schottky diodes, so they cannot be more than $\sim \pm 0.35\ \text{V}$ apart.

2.2 Autocalibration

To ensure DC offset accuracy, the amplifier must be self-calibrated within the 24 hours preceding a measurement. A valid autocalibration must take place at $(23 \pm 5)\ ^\circ\text{C}$ with the module warmed up for at least 2 hours at $(23 \pm 5)\ ^\circ\text{C}$. If the module is being used inside the SIM900 Mainframe, the autocalibration must also be inside the mainframe. Otherwise, perform the autocalibration with the same connection to an independent supply as you use for the operation. The autocalibration is only accurate if the output has stabilized within $\pm 15\ \text{mV}$ of zero for at least 2 minutes immediately preceding the calibration. However, the gain and the offset need not be at

their default values; after the calibration completes, these values are restored.

Disconnect all inputs and outputs to the SIM983 while performing the autocalibration. To calibrate, issue the command `ACAL`, or press the button [polarity] and one of [gain ▲▼] at the same time. The calibration completes and the instrument is ready for operation within 2 seconds. If autocalibration is unsuccessful, for example because an external voltage (which cannot be nulled) is applied to the input, the calibration parameters revert to their original values and the command `LDDE?` will return Code 1.

Autocalibration does not affect gain accuracy.

2.3 AC Characteristics

2.3.1 Bandwidth

The gain-bandwidth product (GBP) of the SIM983 is a measure of its small-signal behavior, and depends on $|G|$. Four gain ranges correspond to four values of gain-bandwidth product, as specified in the table on Page vi. For $|G| \geq 1$, the -3 dB small-signal bandwidth of the amplifier is $f_{-3\text{dB}} = \text{GBP}/|G|$. For $|G| < 1$, $f_{-3\text{dB}}(G) \approx f_{-3\text{dB}}(G = 1.00)$.

The gain-bandwidth product is determined by a compensation capacitor in the feedback path of the gain-stage amplifier. It is possible to override the value of this capacitor, giving the instrument more bandwidth. To do this, use the command `BWTH`. If the bandwidth is altered in this way, the next front-panel button press will return the bandwidth to the value appropriate for the current gain. Cycling the power or performing an autocalibration will also return the bandwidth to its default value for the gain.

If the bandwidth is set to a value other than its default, the amplifier may exhibit slow settling, excessive ringing, or oscillations.

The small-signal settling time of the amplifier is a complex function of its gain and its bandwidth.

2.3.2 Slew rate

The slew rate of an amplifier is a measure of its large-signal behavior. It is the maximum rate of change of the output voltage, measured in V/s. The slew rate (SR) determines the maximum undistorted AC signal that can be output; for a sine-wave output at a frequency f , the maximum peak-peak voltage is $|V_{\text{max}} - V_{\text{min}}| = \text{SR}/(\pi f)$. The SIM983 is designed to be able to output a full-range sine wave at 1 MHz.

If the output or an intermediate stage of the amplifier is driven beyond the limits in the table on Page vi, large-signal behavior is not guaranteed.

2.4 Clock Stopping

The microprocessor clock of the SIM983 stops if the module is idle, “freezing” the digital circuitry. The following actions “wake up” the clock:

1. A power-on.
2. A press of a front-panel button.
3. Activity (send or receive) at the remote interface.
4. An overload.

The clock runs for as long as is necessary to complete a gain or offset adjustment, or to communicate the output of a query through the remote interface. However, the clock will remain active for as long as the overload condition exists.

This default behavior can be modified with the remote command *AWAK*. Setting *AWAK ON* will prevent the clock from stopping. The module returns to *AWAK OFF* upon power-on.

3 Remote Operation

This chapter describes operating the SIM983 over the serial interface.

In This Chapter

3.1	Index of Common Commands	3-2
3.2	Alphabetic List of Commands	3-4
3.3	Introduction	3-6
3.3.1	Power-on configuration	3-6
3.3.2	Buffers	3-6
3.3.3	Device Clear	3-6
3.4	Commands	3-7
3.4.1	Command syntax	3-7
3.4.2	Notation	3-8
3.4.3	Examples	3-8
3.4.4	General commands	3-9
3.4.5	Configuration commands	3-10
3.4.6	Calibration commands	3-11
3.4.7	Status commands	3-11
3.4.8	Interface commands	3-14
3.4.9	Serial communication commands	3-17
3.5	Status Model	3-19
3.5.1	Status Byte (SB)	3-20
3.5.2	Service Request Enable (SRE)	3-20
3.5.3	Standard Event Status (ESR)	3-20
3.5.4	Standard Event Status Enable (ESE)	3-21
3.5.5	Communication Error Status (CESR)	3-21
3.5.6	Communication Error Status Enable (CESE)	3-22
3.5.7	Overload Status (OLSR)	3-22
3.5.8	Overload Status Enable (OLSE)	3-23

3.1 Index of Common Commands

Symbol	Definition
<i>f</i>	Floating-point value
<i>i</i>	Bit number (0-7)
<i>j</i>	Unsigned integer (0-255)
<i>m</i>	Unsigned integer (0-3)
<i>z</i>	Literal token
(?)	Required for queries; illegal for set commands
<i>var</i>	Parameter always required
{ <i>var</i> }	Required parameter for set commands; illegal for queries
[<i>var</i>]	Optional parameter for both set and query forms

General

HELP(?)	3-9 Instrument Help
AWAK(?) { <i>z</i> }	3-10 Keep Clock Awake

Configuration

GAIN(?) { <i>f</i> }	3-10 Gain
OFST(?) { <i>f</i> }	3-10 Offset
BWTH(?) [<i>m</i>]	3-11 Bandwidth

Calibration

ACAL	3-11 Autocalibration
------	----------------------

Status

*CLS	3-11 Clear Status
*STB? [<i>i</i>]	3-12 Status Byte
*SRE(?) [<i>i</i> ,] { <i>j</i> }	3-12 Service Request Enable
*ESR? [<i>i</i>]	3-12 Standard Event Status
*ESE(?) [<i>i</i> ,] { <i>j</i> }	3-12 Standard Event Status Enable
CESR? [<i>i</i>]	3-12 Communication Error Status
CESE(?) [<i>i</i> ,] { <i>j</i> }	3-13 Communication Error Status Enable
OLSR? [<i>i</i>]	3-13 Overload Status
OLSE(?) [<i>i</i> ,] { <i>j</i> }	3-13 Overload Status Enable
PSTA(?) { <i>z</i> }	3-13 Pulse -STATUS Mode
LBTN?	3-13 Last Button
OVLN?	3-14 Overload

Interface

*RST	3-14 Reset
*IDN?	3-15 Identify
*TST?	3-15 Self Test

*OPC(?)	3-15	Operation Complete
CONS(?) {z}	3-15	Console Mode
LEXE?	3-16	Execution Error
LCME?	3-16	Command Error
LDDE?	3-17	Device Error
TOKN(?) {z}	3-17	Token Mode
TERM(?) {z}	3-17	Response Termination

Serial Communications

PARI(?) {z}	3-18	Parity
-------------	------	--------

3.2 Alphabetic List of Commands

★

*CLS	3-11 Clear Status
*ESE(?) [i,] {j}	3-12 Standard Event Status Enable
*ESR? [i]	3-12 Standard Event Status
*IDN?	3-15 Identify
*OPC(?)	3-15 Operation Complete
*RST	3-14 Reset
*SRE(?) [i,] {j}	3-12 Service Request Enable
*STB? [i]	3-12 Status Byte
*TST?	3-15 Self Test

A

ACAL	3-11 Autocalibration
AWAK(?) {z}	3-10 Keep Clock Awake

B

BWTH(?) [m]	3-11 Bandwidth
-------------	----------------

C

CESE(?) [i,] {j}	3-13 Communication Error Status Enable
CESR? [i]	3-12 Communication Error Status
CONS(?) {z}	3-15 Console Mode

G

GAIN(?) {f}	3-10 Gain
-------------	-----------

H

HELP(?)	3-9 Instrument Help
---------	---------------------

L

LBTN?	3-13 Last Button
LCME?	3-16 Command Error
LDDE?	3-17 Device Error
LEXE?	3-16 Execution Error

O

OFST(?) {f}	3-10 Offset
OLSE(?) [i,] {j}	3-13 Overload Status Enable
OLSR? [i]	3-13 Overload Status
OVLDT?	3-14 Overload

P

PARI(?) {z}	3-18 Parity
PSTA(?) {z}	3-13 Pulse \rightarrow STATUS Mode

T

TERM(?) {z}	3-17 Response Termination
TOKN(?) {z}	3-17 Token Mode

3.3 Introduction

Remote operation of the SIM983 is through a simple command language documented in this chapter. Both set and query forms of most commands are supported, allowing the user complete control of the amplifier from a remote computer, either through the SIM900 Mainframe or directly via RS-232 (see Section 1.6.2.1).

See Table 1.1 for the specification of the DB-15 SIM Interface Connector.

3.3.1 Power-on configuration

The initial settings for the remote interface are 9600 baud with no parity and no flow control, and with local echo disabled (**CONS OFF**).

The values of the gain and the offset are retained in non-volatile memory. Upon power-on, those settings are restored to their values before the power was turned off. The bandwidth is set to the value appropriate for the stored gain.

Where appropriate, the default or power-on value for parameters is listed in **boldface** in the command descriptions.

3.3.2 Buffers

The SIM983 stores incoming bytes from the host interface in a 64-byte input buffer. Characters accumulate in the input buffer until a command terminator (either **<CR>** or **<LF>**) is received, at which point the message is parsed and executed. Query responses from the SIM983 are buffered in a 64-byte output queue.

If the input buffer overflows, then all data in *both* the input buffer and the output queue are discarded, and an error is recorded in the CESR and ESR status registers.

3.3.3 Device Clear

The SIM983 host interface can be asynchronously reset to its power-on configuration by sending an RS-232-style **<break>** signal. From the SIM900 Mainframe, this is accomplished with the **SRST** command; if directly interfacing via RS-232, then use a serial break signal. After receiving the Device Clear, the **CONS** mode is turned **OFF**. Note that this *only* resets the communication interface; the basic function of the SIM983 is left unchanged; to reset the amplifier, use ***RST**.

The Device Clear signal will also terminate the output of the **HELP?** command from the SIM983.

3.4 Commands

This section provides syntax and operational descriptions for remote commands.

3.4.1 Command syntax

The four letter mnemonic (shown in CAPS) in each command sequence specifies the command. The rest of the sequence consists of parameters.

Commands may take either *set* or *query* form, depending on whether the “?” character follows the mnemonic. *Set only* commands are listed without the “?”, *query only* commands show the “?” after the mnemonic, and *optionally query* commands are marked with a “(?)”.

Parameters shown in { } and [] are not always required. Parameters in { } are required to set a value, and should be omitted for queries. Parameters in [] are optional in both set and query commands. Parameters listed without surrounding characters are always required.

Do *not* send () or { } or [] as part of the command.

Multiple parameters are separated by commas. Multiple commands may be sent on one command line by separating them with semicolons (;) so long as the input buffer does not overflow. Commands are terminated by either <CR> or <LF> characters. Null commands and whitespaces are ignored. Execution of the command does not begin until the command terminator is received.

tokens *Token* parameters (generically shown as Z in the command descriptions) can be specified either as a keyword or as an integer value. Command descriptions list the valid keyword options, with each keyword followed by its corresponding integer value. For example, to set the response termination sequence to <CR>+<LF>, the following two commands are equivalent:

TERM CRLF —or— TERM 3

For queries that return token values, the return format (keyword or integer) is specified with the TOKN command.

3.4.2 Notation

The following table summarizes the notation used in the command descriptions:

Symbol	Definition
<i>f</i>	Floating-point value
<i>i</i>	Bit number (0-7)
<i>j</i>	Unsigned integer (0-255)
<i>m</i>	Unsigned integer (0-3)
<i>z</i>	Literal token
(?)	Required for queries; illegal for set commands
<i>var</i>	Parameter always required
{ <i>var</i> }	Required parameter for set commands; illegal for queries
[<i>var</i>]	Optional parameter for both set and query forms

3.4.3 Examples

Each command is provided with a simple example illustrating its usage. In these examples, all data sent by the host computer to the SIM983 are set as *straight teletype font*, while responses received by the host computer from the SIM983 are set as *slanted teletype font*.

The usage examples vary with respect to set/query, optional parameters, and token formats. These examples are not exhaustive, and are intended to provide a convenient starting point for user programming.

3.4.4 General commands

HELP(?) Instrument Help

Outputs a condensed version of Section 3.4 to the remote interface.

HELP may be used with or without the query sign, with the same effects.

Example: HELP?

Notation:

f is a floating-point number;

i is bit number (0..7);

j is an 8-bit unsigned integer (0..255);

m is a 2-bit unsigned integer (0..3);

z is a token

(?) question required for queries, illegal for set commands;

[] = parameter is optional for both set and query forms;

{ } = parameter is required to set, illegal for queries;

parameter without brackets is always required;

the brackets themselves should not be sent.

General commands:

HELP? - Send this text.

AWAK(?) {z} - Keep the module clock awake.

Configuration commands:

GAIN(?) {f} - Set/query gain.

OFST(?) {f} - Set/query offset.

BWTH(?) [m] - Output bandwidth.

Calibration commands:

ACAL - One-time autocalibration.

Status commands:

**CLS - Clear Status.*

**STB? [i] - Query the Status Byte.*

**SRE(?) [i,] {j} - Service Request Enable.*

**ESR? [i] - Query Standard Event Status register.*

**ESE(?) [i,] {j} - Standard Event Status Enable.*

CESR? [i] - Query the Communications Error Status.

CESE(?) [i,] {j} - Communications Error Status Enable.

OLSR? [i] - Query Overload Status register.

OLSE(?) [i,] {j} - Overload Status Enable.

PSTA(?) {z} - Pulse Status or change its level.

LBTN? - Which button last pressed?

OVLVD? - Input or output currently overloaded?

Interface commands:

<i>*RST</i>	- Reset to known state.
<i>*IDN?</i>	- Identify.
<i>*TST?</i>	- Does nothing.
<i>*OPC(?)</i>	- Operation complete.
<i>CONS(?) {z}</i>	- Console OFF/ON.
<i>LEXE?</i>	- Last Execution Error.
<i>LCME?</i>	- Last Communications Error.
<i>LDDE?</i>	- Last Device-Dependent Error.
<i>TOKN(?) {z}</i>	- Turn token mode OFF/ON.
<i>TERM(?) {z}</i>	- Cmd line end (NONE, CR, LF, CRLF, LFCR).

Serial interface command (baud rate is always 9600):

<i>PARI(?) {z}</i>	- Parity (NONE, EVEN, ODD, MARK, SPACE).
--------------------	--

AWAK(?) {z}

Keep Clock Awake

Set (query) the SIM983 keep-awake mode {to $z = (\text{OFF } 0, \text{ON } 1)$ }.

Ordinarily, the clock oscillator for the SIM983 microcontroller is held in a stopped state, and only enabled during processing of events (Section 2.4). Setting AWAK ON forces the clock to stay running, and is useful only for diagnostic purposes.

Example: AWAK ON

3.4.5 Configuration commands**GAIN(?) {f}**

Gain

Set (query) the amplifier gain {to f }. The module accepts signed floating-point values in the ranges $-19.99 \leq f \leq -0.01$, $0.01 \leq f \leq 19.99$. The reset value is $f = +1.00$.

After a GAIN set command, the bandwidth is set to the value appropriate for the new gain. Gain queries do not alter the bandwidth.

Example: GAIN 1.4232E1; GAIN?
+14.23

OFST(?) {f}

Offset

Set (query) the offset of the amplifier {to f volts}. The module accepts signed floating-point values in the range $-10.000 \leq f \leq 10.000$. The reset value is $f = 0.000$.

Setting or querying the offset does not change the bandwidth.

Example: OFST -7.032; OFST?
-07.030

BWTH(?) [*m*]

Bandwidth

Set (query) the gain-bandwidth product of the amplifier [to *m*]. Allowed values of the optional parameter are 0 through 3, with a larger value corresponding to a greater gain-bandwidth. When the gain is set from the front panel or from the remote interface, the bandwidth automatically reverts to the following:

Range	Bandwidth <i>m</i>	GBP, MHz min
$0.01 \leq G \leq 2.39$	0	3.0 ($ G \geq 1.00$)
$2.40 \leq G \leq 4.19$	1	5.0
$4.20 \leq G \leq 9.59$	2	10.0
$9.60 \leq G \leq 19.99$	3	17.0

The bandwidth is also automatically selected from this table if the optional parameter is omitted.

Example: GAIN 17; BWTH 1; BWTH?
1
GAIN 17; BWTH?
3

3.4.6 Calibration commands

ACAL

Autocalibration

Perform a self-calibration (Section 2.2). *Make sure to disconnect all inputs and outputs to the SIM983, and to set the output to zero.* Remote commands are not processed until ACAL is complete.

Example: ACAL
LDDE?
0
checks for success of an autocalibration.

3.4.7 Status commands

The Status commands query and configure registers associated with status reporting of the SIM983. See Section 3.5 for the status model.

*CLS

Clear Status

*CLS immediately clears the ESR, CESR, and OLSR status registers.

Example: *CLS

*STB? [i]	<p>Status Byte</p> <p>Query the Status Byte register [Bit <i>i</i>].</p> <p>Execution of the *STB? query (without the optional Bit <i>i</i>) always causes the \negSTATUS signal to be deasserted. Note that *STB? <i>i</i> will <i>not</i> clear \negSTATUS, even if Bit <i>i</i> is the only bit presently causing the \negSTATUS signal.</p> <p><i>Example:</i> *STB? 16</p>
<hr/>	
*SRE(?) [i,] {j}	<p>Service Request Enable</p> <p>Set (query) the Service Request Enable register [Bit <i>i</i>] {to <i>j</i>}.</p> <p><i>Example:</i> *SRE 0, 1</p>
<hr/>	
*ESR? [i]	<p>Standard Event Status</p> <p>Query the Standard Event Status Register [Bit <i>i</i>].</p> <p>Upon execution of *ESR?, the returned bit(s) of the ESR register are cleared.</p> <p><i>Example:</i> *ESR? 64</p>
<hr/>	
*ESE(?) [i,] {j}	<p>Standard Event Status Enable</p> <p>Set (query) the Standard Event Status Enable register [Bit <i>i</i>] {to <i>j</i>}.</p> <p><i>Example:</i> *ESE 6, 1 ESE? 64</p>
<hr/>	
CESR? [i]	<p>Communication Error Status</p> <p>Query the Communication Error Status Register [Bit <i>i</i>].</p> <p>Upon executing a CESR? query, the returned bit(s) of the CESR register are cleared.</p> <p><i>Example:</i> CESR? 0</p>

CESE(?) [i,] {j}	<p>Communication Error Status Enable</p> <p>Set (query) the Communication Error Status Enable register [Bit <i>i</i>] {to <i>j</i>}.</p> <p><i>Example:</i> CESE? 2</p>
------------------	---

OLSR? [i]	<p>Overload Status</p> <p>Query the Overload Status Register [Bit <i>i</i>].</p> <p>Upon executing an OLSR? query, the returned bit(s) of the OLSR register are cleared.</p> <p><i>Example:</i> OLSR? 3</p>
-----------	---

OLSE(?) [i,] {j}	<p>Overload Status Enable</p> <p>Set (query) the Overload Status Enable register [Bit <i>i</i>] {to <i>j</i>}.</p> <p><i>Example:</i> OLSE 4</p>
------------------	--

PSTA(?) {z}	<p>Pulse \negSTATUS Mode</p> <p>Set (query) the Pulse \negSTATUS mode {to <i>z</i> = (OFF 0, ON 1)}.</p> <p>When PSTA ON is set, all new service requests will only <i>pulse</i> the \negSTATUS signal LOW (for a minimum of 1 μs). The default behavior is to latch \negSTATUS LOW until a *STB? query is received.</p> <p>A reset does not alter PSTA. The value in boldface above is the power-on value.</p> <p><i>Example:</i> PSTA? OFF</p>
-------------	---

LBTN?	<p>Last Button</p> <p>Query the number of the last button pressed. The response is</p> <table border="1" style="margin-left: 20px;"> <thead> <tr> <th style="border-right: 1px solid black;">LBTN?</th> <th>Last button</th> </tr> </thead> <tbody> <tr><td style="border-right: 1px solid black;">1</td><td>[polarity]</td></tr> <tr><td style="border-right: 1px solid black;">2</td><td>[gain ▲]</td></tr> <tr><td style="border-right: 1px solid black;">3</td><td>[gain ▼]</td></tr> <tr><td style="border-right: 1px solid black;">4</td><td>[offset ▲]</td></tr> <tr><td style="border-right: 1px solid black;">5</td><td>[offset ▼]</td></tr> <tr><td style="border-right: 1px solid black;">6</td><td>Both [gain ▲] and [gain ▼] (reset gain)</td></tr> <tr><td style="border-right: 1px solid black;">7</td><td>Both [offset ▲] and [offset ▼] (reset offset)</td></tr> <tr><td style="border-right: 1px solid black;">8</td><td>One of [gain ▲▼] and [polarity] (autocalibrate)</td></tr> </tbody> </table>	LBTN?	Last button	1	[polarity]	2	[gain ▲]	3	[gain ▼]	4	[offset ▲]	5	[offset ▼]	6	Both [gain ▲] and [gain ▼] (reset gain)	7	Both [offset ▲] and [offset ▼] (reset offset)	8	One of [gain ▲▼] and [polarity] (autocalibrate)
LBTN?	Last button																		
1	[polarity]																		
2	[gain ▲]																		
3	[gain ▼]																		
4	[offset ▲]																		
5	[offset ▼]																		
6	Both [gain ▲] and [gain ▼] (reset gain)																		
7	Both [offset ▲] and [offset ▼] (reset offset)																		
8	One of [gain ▲▼] and [polarity] (autocalibrate)																		

The value 0 is returned if no button was pressed since the last LBTN? .

A query of LBTN? always clears the button code, so a subsequent LBTN? will return 0.

Example: LBTN?
5

OVLD?

Overload

Query the current overload condition. The response is

OVLD?	Overloaded
1	Input
2	Input + offset
4	Output

Combination overloads are reported by summing the values of the individual overload flags. This command complements the OLSR status register described in Section 3.5.7, and the three overload flags correspond one-to-one with bits in OLSR. However, once cleared by OLSR? or *CLS, the overload status bits will stay cleared even though the overload condition may persist and remain reported by OVLD? .

Example: OVLD?
6

implies that the input is *not* overloaded; the intermediate stage ($V_{in} + V_{ofs}$) *is* overloaded; and the output *is* overloaded.

3.4.8 Interface commands

The Interface commands provide control over the interface between the SIM983 and the host computer.

*RST

Reset

Reset the SIM983 to its default configuration.

*RST sets the following:

- Clock oscillator to stop during idle time (AWAK OFF).
- Gain to +1.00.
- Offset to 0.000 V.
- Bandwidth to 0.
- The token mode to OFF.

*RST does *not* affect PSTA, CONS, TERM, and all service-enable registers (*SRE, *ESE, CESE, or OLSE).

Example: *RST
CONS?
1

*IDN? Identify
Query the device identification string.
The identification string is formatted as:
Stanford_Research_Systems, SIM983, s/n*****, ver#.###
where SIM983 is the model number, ***** is a 6-digit serial number,
and #.### is the firmware revision level.

Example: *IDN?
Stanford_Research_Systems, SIM983, s/n004900, ver2.0

*TST? Self Test
There is no internal self-test in the SIM983 after the power-on, so this query always returns 0.

Example: *TST?
0

*OPC(?) Operation Complete
Sets the OPC flag in the ESR register.
The query form *OPC? writes a 1 into the output queue when complete, but does not affect the ESR register.

Example: *OPC?
1

CONS(?) {z} Console Mode
Set (query) the console mode {to z = (**OFF 0**, ON 1)}.
CONS causes each character received at the input buffer to be copied to the output queue.
A reset does not alter CONS. The value in boldface above is the power-on value. CONS is set to OFF upon Device Clear.

Example: CONS ON

LEXE?

Execution Error

Query the Last Execution Error code. A query of LEXE? always clears the error code, so a subsequent LEXE? will return 0. Valid codes are:

Value	Definition
0	No execution error since last LEXE?
1	Illegal value
2	Wrong token
3	Invalid bit

Example: *STB? 12; LEXE?; LEXE?

3

0

The error (3, "Invalid bit") is because *STB? only allows bit-specific queries of 0–7. The second read of LEXE? returns 0.

LCME?

Command Error

Query the Last Command Error code. A query of LCME? always clears the error code, so a subsequent LCME? will return 0. Valid codes are:

Value	Definition
0	No command error since last LCME?
1	Illegal command
2	Undefined command
3	Illegal query
4	Illegal set
5	Missing parameter(s)
6	Extra parameter(s)
7	Null parameter(s)
8	Parameter buffer overflow
9	Bad floating point
10	Bad integer
11	Bad integer token
12	Bad token value
14	Unknown token

Example: *IDN

LCME?

4

The error (4, "Illegal set") is due to the missing "?".

LDDE?	<p>Device Error</p> <p>Query the Last Device-Dependent Error code. A query of LDDE? always clears the error code, so a subsequent LDDE? will return 0. Valid codes are:</p> <table border="1"> <thead> <tr> <th>Value</th> <th>Definition</th> </tr> </thead> <tbody> <tr> <td>0</td> <td>No execution error since last LEXE?</td> </tr> <tr> <td>1</td> <td>Unable to autocalibrate</td> </tr> </tbody> </table> <p><i>Example:</i> ACAL LDDE? 0 indicates a successful autocalibration.</p>	Value	Definition	0	No execution error since last LEXE?	1	Unable to autocalibrate
Value	Definition						
0	No execution error since last LEXE?						
1	Unable to autocalibrate						

TOKEN(?) {z}	<p>Token Mode</p> <p>Set (query) the token query mode {to z = (OFF 0, ON 1)}.</p> <p>If TOKEN ON is set, then queries to the SIM983 that return tokens will return a text keyword; otherwise they return a decimal integer value. Thus, the only possible responses to the TOKEN? query are ON and 0.</p> <p><i>Example:</i> TOKEN OFF</p>
--------------	---

TERM(?) {z}	<p>Response Termination</p> <p>Set (query) the <term> sequence {to z = (NONE 0, CR 1, LF 2, CRLF 3, or LFCR 4)}.</p> <p>The <term> sequence is appended to all query responses sent by the module, and is constructed of ASCII character(s) 13 (carriage return) and 10 (line feed). The token mnemonic gives the sequence of characters.</p> <p>A reset does not alter TERM. The value in boldface above is the power-on value.</p> <p><i>Example:</i> TOKEN ON; TERM? CRLF</p>
-------------	---

3.4.9 Serial communication commands

Note that the SIM983 can only support a single baud rate of 9600, and does not support flow control. A reset does not change the serial interface settings; use Device Clear.

PARI(?) {z}

Parity

Set (query) the parity {to z = (**NONE 0**, ODD 1, EVEN 2, MARK 3, SPACE 4)}. The value in boldface is the power-on value.

Example: TOKN ON; PARI?
EVEN

3.5 Status Model

status registers The SIM983 status registers follow the hierarchical IEEE-488.2 format. A block diagram of the status register array is given in Figure 3.1.

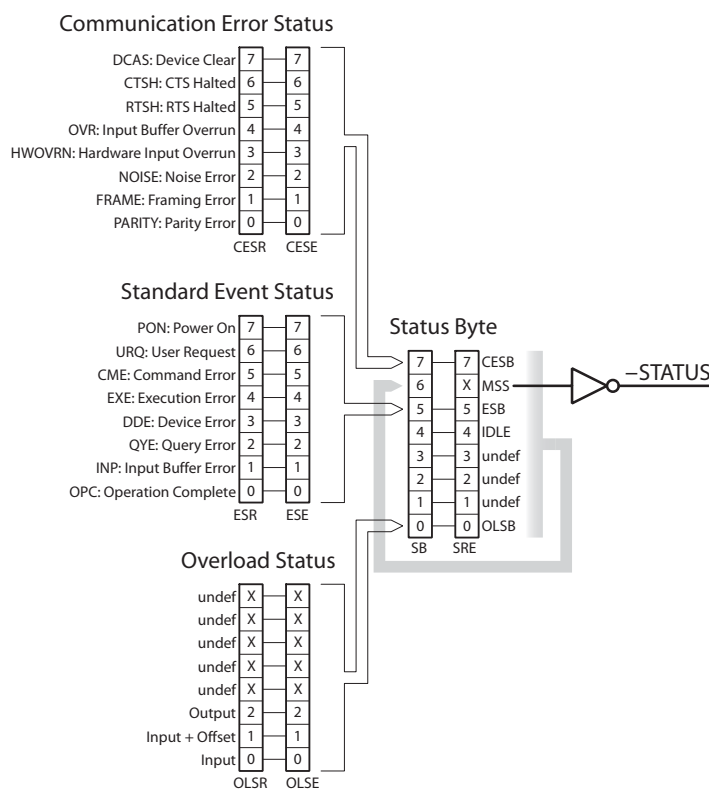

Figure 3.1: Status register model for the SIM983 Scaling Amplifier.

There are two categories of registers in the SIM983 status model:

Event Registers : These read-only registers record the occurrence of defined events. If the event occurs, the corresponding bit is set to 1. Upon querying an event register, all set bits within it are cleared. These are sometimes known as “sticky bits,” since once set, a bit can only be cleared by reading its value. Event register names end with SR.

Enable Registers : These read/write registers define a bitwise mask for their corresponding event register. If a bit position is set in an event register while the same bit position is also set in the enable register, then the corresponding summary bit message is set. Enable register names end with SE.

At power-on, all status registers are cleared.

3.5.1 Status Byte (SB)

The Status Byte is the top-level summary of the SIM983 status model. When masked by the Service Request Enable register, a bit set in the Status Byte causes the \neg STATUS signal to be asserted on the rear-panel SIM interface connector.

Weight	Bit	Flag
1	0	OLSB
2	1	undef (0)
4	2	undef (0)
8	3	undef (0)
16	4	IDLE
32	5	ESB
64	6	MSS
128	7	CESB

OLSB : Overload Summary Bit. Indicates whether one or more of the enabled flags in the Overload Status Register has become true.

IDLE : Indicates that the input buffer is empty and the command parser is idle. Can be used to help synchronize SIM983 query responses.

ESB : Event Status Bit. Indicates whether one or more of the enabled events in the Standard Event Status Register is true.

MSS : Master Summary Status. Indicates whether one or more of the enabled status messages in the Status Byte register is true.

CESB : Communication Error Summary Bit. Indicates whether one or more of the enabled flags in the Communication Error Status Register has become true.

3.5.2 Service Request Enable (SRE)

Each bit in the SRE corresponds one-to-one with a bit in the SB register, and acts as a bitwise AND of the SB flags to generate MSS. Bit 6 of the SRE is undefined—setting it has no effect, and reading it always returns 0. This register is set and queried with the **SRE(?)* command.

At power-on, this register is cleared.

3.5.3 Standard Event Status (ESR)

The Standard Event Status Register consists of 8 event flags. These event flags are all “sticky bits” that are set by the corresponding events, and cleared only by reading or with the **CLS* command. Reading a single bit (with the **ESR? i* query) clears only Bit *i*.

Weight	Bit	Flag
1	0	OPC
2	1	INP
4	2	QYE
8	3	DDE
16	4	EXE
32	5	CME
64	6	URQ
128	7	PON

OPC : Operation Complete. Set by the *OPC command.

INP : Input buffer error. Indicates data has been discarded from the input buffer.

QYE : Query Error. Indicates data in the output queue has been lost.

DDE : Device-Dependent Error. Indicates a failed autocalibration.

EXE : Execution Error. Indicates the error in a command that was successfully parsed. Out-of-range parameters are an example.

CME : Command Error. Indicates a command parser-detected error.

URQ : User Request. Indicates that a front-panel button was pressed.

PON : Power On. Indicates that an off-to-on transition has occurred.

3.5.4 Standard Event Status Enable (ESE)

The ESE acts as a bitwise AND with the ESR register to produce the single-bit ESB message in the Status Byte Register (SB). The register can be set and queried with the *ESE(?) command.

At power-on, this register is cleared.

3.5.5 Communication Error Status (CESR)

The Communication Error Status Register consists of 8 event flags; each of the flags is set by the corresponding event, and cleared only by reading the register or with the *CLS command. Reading a single bit (with the CESR? *i* query) clears only Bit *i*.

Weight	Bit	Flag
1	0	PARITY
2	1	FRAME
4	2	NOISE
8	3	HWOVRN
16	4	OVR
32	5	RTSH
64	6	CTSH
128	7	DCAS

- PARITY : Parity error. Set by serial parity mismatch on the incoming data byte.
- FRAME : Framing error. Set when an incoming serial data byte is missing the STOP bit.
- NOISE : Noise error. Set when an incoming serial data byte does not present a steady logic level during each asynchronous bit-period window.
- HWOVRN : Hardware Overrun. Set when an incoming serial data byte is lost due to internal processor latency. Causes the input buffer to be flushed, and resets the command parser.
- OVR : Input buffer Overrun. Set when the input buffer is overrun by the incoming data. Causes the input buffer to be flushed, and resets the command parser.
- RTSH : RTS Holdoff Event. Unused in the SIM983.
- CTSH : CTS Holdoff Event. Unused in the SIM983.
- DCAS : Device Clear. Indicates that the SIM983 received the Device Clear signal (an RS-232 <break>). Clears the input buffer and the output queue, and resets the command parser.

3.5.6 Communication Error Status Enable (CESE)

The CESE acts as a bitwise AND with the CESR register to produce the single-bit CESB message in the Status Byte Register (SB). The register can be set and queried with the CESE(?) command.

At power-on, this register is cleared.

3.5.7 Overload Status (OLSR)

The Overload Status Register consists of 3 event flags; each of the flags is set by the corresponding overload, and cleared only by reading the register or with the *CLS command. Reading a single bit (with the OLSR? *i* query) clears only Bit *i*.

Weight	Bit	Flag
1	0	Input
2	1	Input + Offset
4	2	Output
8	3	undef (0)
16	4	undef (0)
32	5	undef (0)
64	6	undef (0)
128	7	undef (0)

Input : Input overload. Indicates that $|V_{in}| > 10.0\text{ V}$ (see also Section 1.2.4.1).

Input + Offset : Intermediate stage overload. Indicates that $|V_{in} + V_{ofs}| > 10.0\text{ V}$.

Output : Output overload. Indicates that $|V_{out}| > 10.0\text{ V}$.

Reading this register (with the OLSR? query) clears all overload bits that are set. If the overload condition persists, the bits will remain cleared until the overload condition ceases and reoccurs. Use OVLD? to query the current state of the overload.

3.5.8 Overload Status Enable (OLSE)

The OLSE acts as a bitwise AND with the OLSR register to produce the single-bit OLSB message in the Status Byte Register (SB). The register can be set and queried with the OLSE(?) command.

At power-on, this register is cleared.

4 Performance Verification

This chapter describes the tests necessary to verify the SIM983 is operating correctly and within specified calibration.

In This Chapter

4.1	Verifying the DC Accuracy	4-2
4.1.1	Getting ready	4-2
4.1.2	Interpreting the accuracy specifications . . .	4-2
4.1.3	Input bias current	4-4
4.2	Verifying AC Performance	4-4
4.2.1	Transfer characteristic	4-4
4.2.2	Step response	4-4
4.2.3	Slew rate	4-6
4.2.4	Total harmonic distortion	4-6
4.3	Noise Characteristics	4-6
4.4	Performance Test Record	4-8
4.4.1	DC test	4-8
4.4.2	Noise test	4-9

4.1 Verifying the DC Accuracy

The gain and the offset of the SIM983 Scaling Amplifier are calibrated at the factory. Besides self-calibration, there are no user-adjustable calibration settings.

4.1.1 Getting ready

To verify the DC performance of the SIM983, one needs a DC signal source (able to output either polarity) and, as a minimum, a voltmeter accurate to $\pm 500 \mu V$ or better. Two voltmeters with matched calibration are most convenient, such as two channels of the Stanford Research Systems' SIM970 Quad DVM. The SIM928 Isolated Voltage Source is recommended as the calibrator; however, the wiper of a potentiometer connected to a power supply can be a simpler if less convenient solution. The DC source must be quiet. If the verification is done with only one voltmeter, cables have to be connected and disconnected between measurements, so the voltage source must be stable within the voltmeter's accuracy. No such stability is required if two voltmeters are used.

1. Warm up the SIM983 for at least 2 hours.
2. If the voltmeter requires a warmup of a certain duration prior to establishing its accuracy specifications, or an autocalibration, be certain to complete these.
3. Perform an autocalibration of the SIM983 as specified in Section 2.2.

In order to perform the measurements, connect the output of the voltage source to the input of the amplifier and to Voltmeter 1. Connect the output of the SIM983 to Voltmeter 2. If using only one voltmeter, use it to alternately measure the DC source voltage and the output voltage of the SIM983.

4.1.2 Interpreting the accuracy specifications

Gain and offset errors specified in the table on Page vi contribute to the overall output error. The error in $V_{\text{out}} = G \times (V_{\text{in}} + V_{\text{ofs}})$ is

$$\delta V_{\text{out}} = \delta G \times (V_{\text{in}} + V_{\text{ofs}}) + G \times \delta V_{\text{ofs}}.$$

The gain error δG and the offset error δV_{ofs} both have temperature-dependent contributions, mentioned in the specification table under "Stability".

4.1.2.1 Error budget

Consider, for example, a measurement with $G = +13.30$, $V_{in} = 6.192\text{ V}$, and $V_{ofs} = -5.480\text{ V}$, performed at a laboratory temperature of $+28\text{ }^\circ\text{C}$.¹ The following are the worst-case contributions of the factors specified in the table on Page vi to the output error:

Specification	Contribution to Overall Error, V
Gain accuracy, ± 0.01	$\pm 0.01 \times (6.192 - 5.480) = \pm 0.0071$
Gain stability, $(28\text{ }^\circ\text{C} - 23\text{ }^\circ\text{C}) \times (\pm 10\text{ ppm}/^\circ\text{C}) = \pm 50 \times 10^{-6}$	$\pm 50 \times 10^{-6} \times (6.192 - 5.480) = \pm 0.0000$
Offset accuracy, $\pm 1\text{ mV} \pm 200\text{ ppm}$	$13.30 \times (\pm 0.001 \pm 200 \times 10^{-6} \times (-5.480)) = \pm 0.0279$
Offset stability, $(28\text{ }^\circ\text{C} - 23\text{ }^\circ\text{C}) \times (\pm 20\text{ } \mu\text{V}/^\circ\text{C} \pm 20\text{ ppm}/^\circ\text{C})$ $= \pm 100\text{ } \mu\text{V} \pm 100 \times 10^{-6}$	$13.30 \times (\pm 0.0001 \pm 100 \times 10^{-6} \times (-5.480)) = \pm 0.0086$
Total	$= \pm 0.0436$

The output of the instrument is therefore

$$V_{out} = 13.30 \times (6.192\text{ V} - 5.480\text{ V}) \pm 0.0436\text{ V} = (9.47 \pm 0.04)\text{ V}$$

if the amplifier is performing within its specifications.

Consider another example, with $G = -0.19$, $V_{in} = -3.954\text{ V}$, and $V_{ofs} = -5.480\text{ V}$, performed at a laboratory temperature of $+23\text{ }^\circ\text{C}$. For $|G| < 1$, the specified offset error term is referenced to the output, according to Note 4 on Page vii. The worst-case error budget is

Specification	Contribution to Overall Error, V
Gain accuracy, ± 0.01	$\pm 0.01 \times (-3.954 - 5.480) = \pm 0.0943$
Offset accuracy, $\pm 1\text{ mV} \pm 200\text{ ppm}$	$\pm 0.001 \pm 200 \times 10^{-6} \times (-0.19) \times (-3.954 - 5.480) = \pm 0.0014$
Total	$= \pm 0.0957$

The stability terms are zero because the test is taken at the calibration temperature. The output of the SIM983 is therefore

$$V_{out} = -0.19 \times (-3.954\text{ V} - 5.480\text{ V}) \pm 0.0957\text{ V} = (1.79 \pm 0.10)\text{ V}$$

if the unit is working according to the specifications.

When interpreting the results of a DC performance test of the SIM983, always account for the voltmeter accuracy specifications.

4.1.2.2 Recalibration

If the module fails its DC accuracy specifications, return it to Stanford Research Systems for a new calibration.

¹ Note that the input voltage by itself, or the output voltage by itself, overloads the amplifier at the chosen gain, but their combination does not.

4.1.3 Input bias current

A simple test of the input current can be done by connecting the input of the SIM983 to the input of a voltmeter that has a microvolt range, such as the SIM970. The current will flow through a parallel combination of the 1 M Ω input resistance of the SIM983 and the input resistance of the voltmeter, which is typically 10 M Ω in the SIM970 and is that or greater in other voltmeters. Divide the voltmeter reading by the resistance (e.g. 0.9 M Ω) to obtain the current. A current that exceeds the specification in the table on Page vi indicates a damaged front end. The module should then be returned to Stanford Research Systems for repair.

4.2 Verifying AC Performance

Most information about the AC behavior of the SIM983 Scaling Amplifier can be deduced by observing the response of the instrument to a square wave at the input. The equipment required for the test is a function generator with at most 25 ns square-wave rise time, such as the Stanford Research Systems' DS345, and an oscilloscope with at least 100 MHz bandwidth. An FFT spectrum analyzer, such as the Stanford Research Systems' SR785, is needed to measure total harmonic distortion and noise.

4.2.1 Transfer characteristic

It is possible to measure the small-signal bandwidth of the amplifier by applying a 100 mV peak-peak sine wave to its input, and increasing the frequency of the applied signal until the output amplitude reduces to -3 dB, i.e. $1/\sqrt{2}$, of its low-frequency value. However, the small-signal bandwidth can also be measured from the rise time of the instrument's response to a small-input step. For example, in Figure 4.1 measure the rise time of the output from 10% to 90%, i.e. -400 mV to $+400$ mV:

$$t_{\text{rise}} = 111 \text{ ns},$$

so the small-signal bandwidth

$$f_{-3 \text{ dB}}(G = 1) = \frac{0.35}{t_{\text{rise}}} = 3.1 \text{ Mhz},$$

which is consistent with the bandwidth expected from $\text{GBP} = 3.0 \text{ MHz}$ in the specification table on Page vi.

4.2.2 Step response

Figures 4.1–4.6 illustrate the typical responses of a SIM983 to steps in the input voltage. Figure 4.2 is for $G = 4.00$, a value near the

top end of the range for $BWTH = 1$. According to the discussion in Section 5.1.2.5, the amplifier is relatively overcompensated, resulting in an increased settling time. Compare with Figure 4.3, with $G = 10.00$ at the low end of the range for $BWTH = 3$. The amplifier is relatively undercompensated, and the smaller phase margin results in some overshoot and ringing.



Figure 4.1: Response of the SIM983 to a 1.0 V peak-peak step, $G = +1.00$, $V_{ofs} = 0.000$ V.

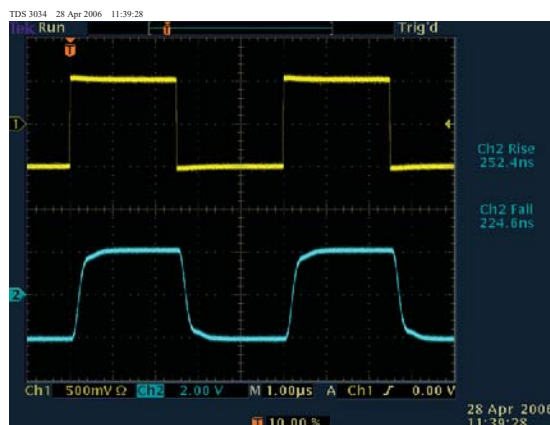

Figure 4.2: Response of the SIM983 to a 1.0 V peak-peak step, $G = +4.00$, $V_{ofs} = 0.000$ V.

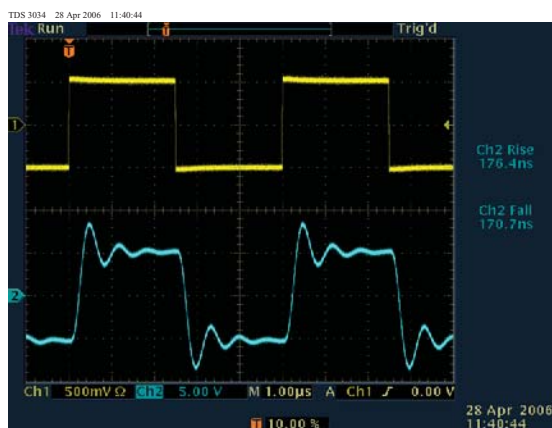

Figure 4.3: Response of the SIM983 to a 1.0 V peak-peak step, $G = +10.00$, $V_{ofs} = 0.000$ V.

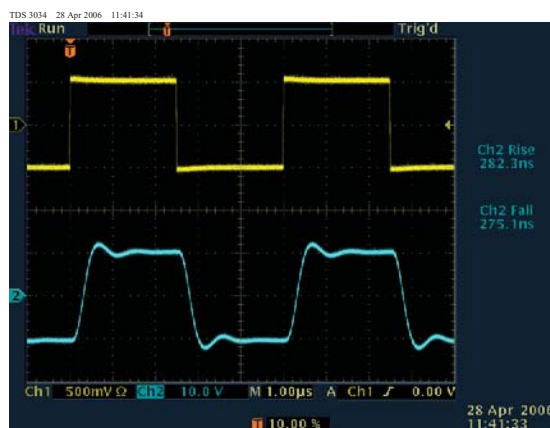

Figure 4.4: Response of the SIM983 to a 1.0 V peak-peak step, $G = +19.99$, $V_{ofs} = 0.000$ V.

The asymmetrical positive-going and negative-going responses in Figures 4.5 and 4.6 are ultimate artifacts of the single-ended, as opposed to differential, topology of the input voltage buffer (Section 5.1.2.1).

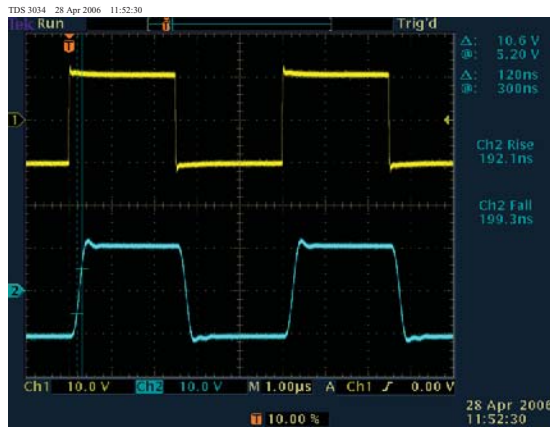

Figure 4.5: Response of the SIM983 to a 20 V peak-peak step, $G = +1.00$, $V_{\text{ofs}} = 0.000$ V.

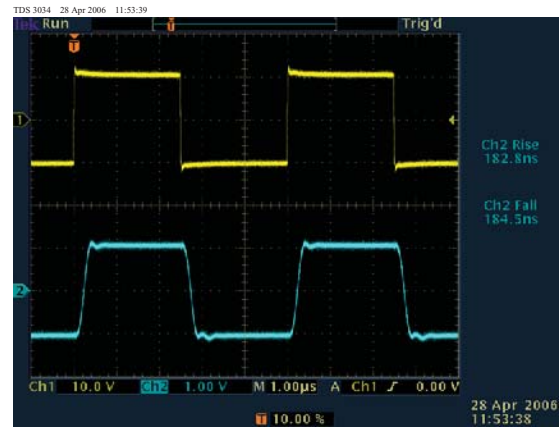

Figure 4.6: Response of the SIM983 to a 20 V peak-peak step, $G = +0.10$, $V_{\text{ofs}} = 0.000$ V.

4.2.3 Slew rate

Slew rate information is contained within the large-input, large-output step response (Figure 4.5).² After an initial delay, the output rises from -5.4 V to $+5.2$ V in 120 ns. The slew rate

$$SR = \frac{5.2 - (-5.4)}{120 \times 10^{-9}} = 88 \text{ V}/\mu\text{s}.$$

4.2.4 Total harmonic distortion

Figure 4.7 shows a distortion measurement made on the SR785 FFT Spectrum Analyzer.

4.3 Noise Characteristics

Figure 4.8 shows noise plots of the SIM983 up to $f = 100$ kHz, measured with an SR785. Note the quite weak dependence of the input-referenced noise on the gain for $|G| \geq 1$. Figure 4.9 shows the time dependence of the output voltage of the SIM983. The 0.17 Hz single-pole high-pass, and 10 Hz eighth-order low-pass filtering was provided by the SIM965 Analog Filter.

²The small-input, large-output step response of Figure 4.4 is limited by the 1.15 MHz bandwidth at $G = 19.99$, so no slew-rate limitation is evident.

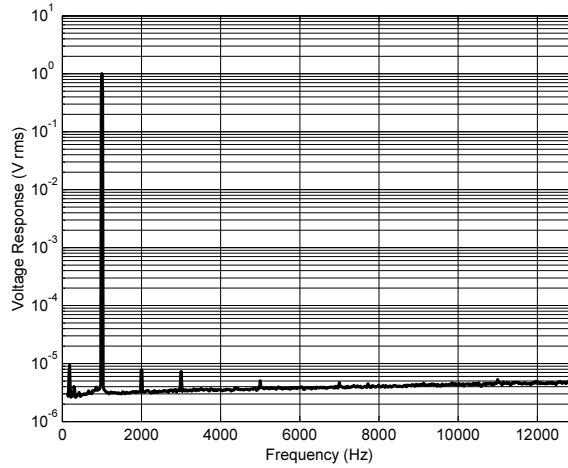

Figure 4.7: Response spectrum of the SIM983 at $G = +1.00$ to a 1.0 kHz, 1.0 V rms sine wave, showing harmonic artifacts at $< 1 \times 10^{-5}$ of the principal. The total THD for 10 harmonics is -96 dB, as measured by an SR785. The THD does not degrade with higher gain, or larger input signal, up to the overload limits of the SIM983.

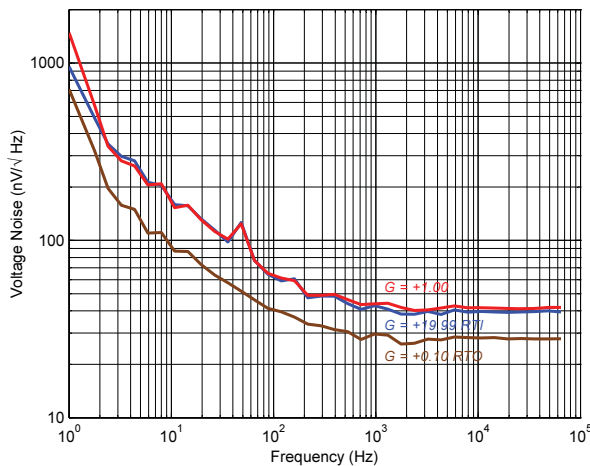

Figure 4.8: Noise of the SIM983, referenced to the input for $|G| \geq 1$.

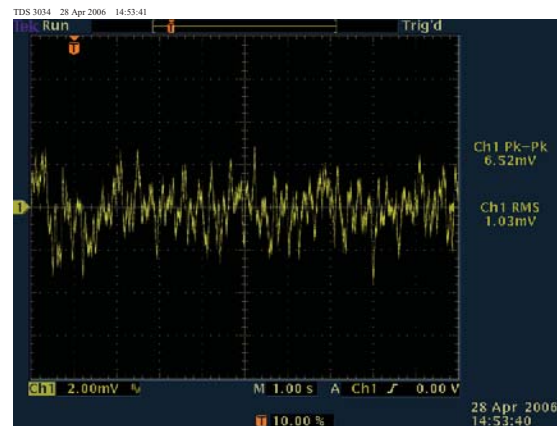

Figure 4.9: 0.1 Hz to 10 Hz noise of the SIM983, $G = +19.99$, additional gain of 50.

4.4 Performance Test Record

4.4.1 DC test

Serial number

Lab temperature (°C) =

G	V_{in} (V)	V_{ofs} (V)	V_{out} (V)	$G \times$ $(V_{in} + V_{ofs})$ (V)	Error (V)	Gain accuracy error (V)	Gain stability error (V)	Offset accuracy error (V)	Offset stability error (V)	Cal within spec?



4.4.2 Noise test

Serial number

Input bias current (pA) =

Noise volage, $\text{nV}/\sqrt{\text{Hz}}$:

	$G = -0.10$	$G = +0.10$	$G = -1.00$	$G = +1.00$	$G = -19.99$	$G = +19.99$
$f = 1 \text{ kHz}$						
$f = 10 \text{ kHz}$						

5 Circuit Description

This chapter presents a brief description of the SIM983 circuit design. A complete parts list and circuit schematics are included.

In This Chapter

5.1	Circuit Discussion	5-2
5.1.1	Microcontroller interface	5-2
5.1.2	The amplifier	5-2
5.1.3	Front panel	5-6
5.2	Parts List	5-6
5.3	Schematic Diagrams	5-10

5.1 Circuit Discussion

The following sections correspond to schematic pages at the end of the manual.

5.1.1 Microcontroller interface

The SIM983 is controlled by microcontroller U107.

5.1.1.1 Digital control and clock stopping

A critical aspect of the design is the clock-stop circuitry implemented by U102 and U105. A simple RC oscillator is enabled or disabled at Pin 1 of U105. This pin is driven by synchronizing flip-flop U102B to ensure that no “runt” clock pulses are produced that would violate the minimum clock period of U107. Four separate clock starting signals are combined by U103 and U104, as discussed in Section 2.4.

The fast start time of the RC oscillator ensures that incoming serial data will be correctly decoded by the microcontroller’s UART, even when the clock is started by the serial start bit of the incoming data. When the microcontroller has completed all pending activity, it drives the STOP signal HIGH (Pin 71 of U107), effectively halting its own processor clock. In this way, the SIM983 guarantees that no digital clock artifacts can be generated during quiescent operation.

5.1.1.2 Power and grounds

A separate clean +5 V source is provided by voltage regulator U109 to power the analog circuitry of the amplifier. Each point in the circuit that connects to Ground 2 (Section 2.1.2) is separately routed to Pin 8 of interface connector J101, forming a star ground on Layer 3 of the circuit board.

5.1.2 The amplifier

The signal path in the SIM983 Scaling Amplifier consists of five stages: the high-impedance input voltage buffer, the summing amplifier, the voltage inverter, the programmable gain stage, and the passive LRC filter. Other parts of the amplifier circuit are the precision voltage reference, the offset voltage generator, and the output microvoltmeter, used for autocalibration.

5.1.2.1 Input voltage buffer

The input buffer is a high-impedance (40 pA max bias current), high-slew-rate (1200 V/ μ s typ.), high-speed (105 MHz typ. small-signal

bandwidth) composite operational amplifier, running at gain 1. Cascoded radiofrequency FET Q201 provides the slew rate and the bandwidth, whereas U201, a precision JFET operational amplifier (op-amp), disciplines Q201 to a maximum of $900\ \mu\text{V}$ of offset voltage, $12\ \mu\text{V}/^\circ\text{C}$ maximum offset drift, and $8.5\ \text{nV}/\sqrt{\text{Hz}}$ typical noise.¹ The output of the voltage buffer is monitored for overload by comparator U213, which trips at the voltage limits specified in Section 1.2.4.1.

5.1.2.2 Offset voltage generator

The offset voltage is provided by U204, a 16-bit digital-to-analog converter (DAC). Because of the ultralow drift of the DAC and precision resistor network R215, the temperature stability of the generated offset is largely determined by the $5\ \text{ppm}/^\circ\text{C}$ typical performance of scaling resistor R217. The integral nonlinearity of U204 puts a 200 ppm limit on the overall accuracy of the instrument's offset. A second, 12-bit DAC U206 allows for fine tuning of the generated offset, cancelling the contribution of the input offset voltage of U201 and offsets in subsequent stages in order to achieve the specified accuracy. The offset voltage is filtered by the $6.3\ \text{k}\Omega$ output resistance of U204 in combination with C206, with $f_{-3\text{dB}} = 11\ \text{Hz}$.

5.1.2.3 Summing amplifier

The voltages at the outputs of the input buffer and the two offset-generating DACs are combined by a summing amplifier built around U208A. This low-noise, high-speed op-amp is disciplined by one half of precision op-amp U207, so its input offset contributes negligibly to the overall offset error and the offset drift. However, the input bias current of the op-amp does contribute to the error, and this contribution is partially cancelled by a constant current injected into the summing node through R219. The remaining contribution is calibrated out via U204 and U206.

At this stage, three major contributions to the overall noise of the SIM983 come into play; these contributions are comparable in magnitude, and add in quadrature. The $1.5\ \text{nV}/\sqrt{\text{Hz}}$ noise (at 10 kHz) of U208 faces a noise gain of 6 from R216 and R217. The input buffer contributes another $9.5\ \text{nV}/\sqrt{\text{Hz}}$. Finally, the Johnson noise of the $2.5\ \text{k}\Omega$ resistors of R216 and the $604\ \Omega$ R217, times the noise gain, yields $16.5\ \text{nV}/\sqrt{\text{Hz}}$, referenced to the input. Therefore, the total noise at the output of this stage is typically $21\ \text{nV}/\sqrt{\text{Hz}}$. The input bias current of U208, passing through the feedback portion

¹ The $9.4\ \text{nV}/\sqrt{\text{Hz}}$ noise at the output of the input voltage buffer includes the contribution of the $1\ \text{k}\Omega$ input protection resistor R203.

of R216, only generates a contribution of $3 \text{ nV}/\sqrt{\text{Hz}}$, insignificant when added in quadrature.

Scaling resistor network R216 is highly stable, and does not contribute appreciably to the drift of the gain.

5.1.2.4 Voltage inverter

The inversion, if required, is performed by the other half of dual op-amp U208. Precision resistor network R222 is connected in such a way that the noise gain of the op-amp is always 2, ensuring stability from oscillation. The Johnson noise of the network contributes to the overall noise of the SIM983, resulting in $22 \text{ nV}/\sqrt{\text{Hz}}$ (typ., at 10 kHz) at the stage's output.

Because the inverting stage is not disciplined, its offset contributes to the overall error; this offset typically drifts by $10 \mu\text{V}/^\circ\text{C}$, and, combined with the drift of the input voltage buffer, this error determines the offset stability of the instrument. The error produced by the input bias current of the op-amp is calibrated out.

The output of the summing amplifier is monitored for overload by comparator U214, triggered at the voltage limits discussed in Section 1.2.4.1.

5.1.2.5 Gain stage

The variable-gain element is one half of high-speed op-amp U211, connected in the inverting configuration. Two matched converters of dual multiplying DAC (MDAC) U210 serve as variable input and feedback resistors for this inverting amplifier:

$$|G| = \frac{R(\text{U210B})}{R(\text{U210A})}.$$

When $|G| \leq 1$, U210B is set to or near its minimum resistance value of $10 \text{ k}\Omega$, and U210A, to an equal or greater resistance. The situation is reversed for $|G| > 1$. The 12-bit resolution of the MDACs places limitations on the values of achievable gains. The two MDACs track to within $10 \text{ ppm}/^\circ\text{C}$, and this term is the dominant one for the stability of the instrument's gain.

Similarly to the summing portion of U208, the gain amplifier (U211A) is disciplined by U207B in order to achieve a negligible contribution to the overall offset, offset drift, and noise. However, the error from the input bias current of U211A (which is multiplied by the resistance $R(\text{U210B})$) is not negligible.² A first-order cancellation of the

²The same part as U208 could not be used in place of U211 because the low-noise U208 is not unity-gain stable.

bias is achieved by mirroring the input current of the second half, U211B, and injecting it into the input node of U211A. The remaining input current produces a drift term that is roughly the same as, or smaller than, the other dominant contributions to the offset stability of the instrument.

This cancellation scheme increases the contribution of the gain stage to the overall noise. The noise current of U211 is multiplied by $R(U210B)$ and by $\sqrt{2}$. As $R(U210B)$ increases linearly with the gain for $|G| \geq 1$, this term yields $21 \text{ nV}/\sqrt{\text{Hz}}$, referenced to the input.

The remaining noise contribution is from $R(U210A)$ and $R(U210B)$. Their Johnson noise at the output of the stage depends on the gain as

$$e_n \propto \sqrt{|G|(1 + |G|)},$$

and for large gains is just the noise of the $10 \text{ k}\Omega$ resistor $R(U210A)$, referenced to the input. This $13.5 \text{ nV}/\sqrt{\text{Hz}}$ term adds in quadrature with the $22 \text{ nV}/\sqrt{\text{Hz}}$ contribution of the earlier three stages, and with the bias-current contribution, to yield $34 \text{ nV}/\sqrt{\text{Hz}}$ ($f \gtrsim 10 \text{ kHz}$). At most frequencies $f \gtrsim 100 \text{ Hz}$, and for $|G| \geq 1$, the input-referenced noise of the SIM983 is independent of the gain to within $2 \text{ nV}/\sqrt{\text{Hz}}$.

The capacitances of the analog switches³ that configure the variable-resistance MDAC add together at the output of the MDAC. This capacitance becomes the input capacitance of the inverting amplifier, and its value places the ultimate limits on the small-signal bandwidth achievable in the gain stage and with it, in the whole instrument. The capacitance together with $R(U210A)$ forms an input pole, so if the gain of the amplifier is not rolled off with a capacitor in the feedback path, the amplifier will oscillate. The amount of compensation feedback capacitance desired for stability from oscillation increases with decreasing $|G|$. The compensation network consists of PFETs Q205–Q208, functioning as switches and chosen for ultralow OFF capacitance, and capacitors C208–C210. One, both, or none of C209 and C210 are inserted into the feedback path for four ranges of the gain, resulting in four possible values of the gain-bandwidth product of the stage (Page vi). With the feedback capacitor selected, the phase margin of the amplifier improves with increasing $|G|$, and with it the overshoot and ringing in the step response decrease.

Output voltage buffer U212 enables the instrument to drive 50Ω loads. Comparator U215 indicates an overload at the specified output voltage limits (Section 1.2.4.2).

³ Internal to the MDAC.

5.1.2.6 Output filter

The performance of the passive filter, composed of L201, R226, R227, and C211, is described on Schematic Page 2. The filter eliminates the broad-spectrum noise of high-bandwidth amplifiers Q201, U208, and U211 beyond a few megahertz, while adding a negligible amount of overshoot in the step response.

5.1.2.7 Output microvoltmeter

The analog-to-digital converter (ADC) used for autocalibration is a part of microcontroller U107. The output signal is amplified by precision op-amp U217, then shifted by +2.5 V by shunt reference D201 and fed into the ADC.

5.1.3 Front panel

Bright red 7-segment LED displays U302, U304, U306, U307, U309, U311, U313, and U314, and overload LEDs D301 and D302 are driven by shift registers U301, U303, U305, U308, U310, U312, and U315.

5.2 Parts List

STANFORD RESEARCH SYSTEMS, INC.						
SIM983 Scaling Amplifier		Circuit Board (1 of 1)			Revision D	
BILL OF MATERIALS		May 5, 2006				
Item	Qty.	Reference	Part	SRS P/N	Manufacturer	Manf. P/N
1	2	C101,C102	22 μ T	5-00327-030	VISHAY	199D226X9035E6B1
2	10	C103,C110,C111,C205,C221, C222,C223,C224,C225,C226	10 μ T	5-00098-030	VISHAY	199D106X9035D2B1
3	1	C104	330p	5-00381-100	KEMET	C1206C331J5GACTM
4	1	C105	9.0--50p	5-00106-090	XICON	24AA024
5	3	C106,C107,C108	1000p	5-00387-100	KEMET	C1206C102J1GACTM
6	5	C109,C217,C218,C219,C220	1.0 μ T	5-00099-030	VISHAY	199D105X9035A2B1
7	1	C201	2.7p NPO \pm 0.25p	5-00630-100	KEMET	C1206C279C5GACTM
8	2	C202,C210	3.3p NPO \pm 0.25p	5-00357-100	KEMET	C1206C339C5GACTM
9	3	C203,C204,C209	1.5p NPO \pm 0.25p	5-00353-100	KEMET	C1206C159C5GACTM
10	2	C206,C216	2.2 μ MPE 5%	5-00584-050	PANASONIC	ECQ-E1225JFB
11	2	C207,C213	4.7 μ MPE 5%	5-00073-050	XICON	146-250V4.7K
12	1	C208	0.5p NPO \pm 0.25p	5-00592-100	AVX	12065A0R5C
13	1	C211	1500p NPO 5%	5-00389-100	KEMET	C1206C152J5GACTM
14	2	C212,C214	1.0 μ MPE 5%	5-00245-050	WIMA	MKS4/1/63/5RM10
15	1	C215	10 μ MPE 10%	5-00072-050	PANASONIC	ECQ-E1106KF

Item	Qty.	Reference	Part	SRS P/N	Manufacturer	Manf. P/N
16	43	X101,X102,X103,X104,X105, X106,X107,X108,X109,X110, X111,X112,X113,X114,X115, X201,X202,X203,X204,X205, X206,X207,X208,X209,X210, X211,X212,X213,X214,X215, X216,X217,X218,X219,X220, X221,X301,X302,X303,X304, X305,X306,X307	0.1 μ	5-00299-100	KEMET	C1206C104K5RACTM
17	2	D101,D102	BAT54S	3-00945-143	DIODES INC	BAT54S-7
18	1	D201	TL431CDBV	3-01133-123	PHILIPS	TL431CD5
19	1	D202	BAV99	3-00896-145	ON SEMI	BAV99LT1
20	2	D301,D302	Red	3-00425-060	LITEON	LTL-709E
21	1	J101	15 Pin D	1-00367-040	CINCH	DAKL-15PATI-E
22	0	J102	Header 0.100" 4x1	no part		
23	1	J103	Socket 0.100" 3x2	1-00302-010	SAMTEC	CES-103-01-G-D
24	1	J104	Header 0.050" 7x2/Mixed	1-01063-109	SAMTEC	FTSH-107-04-L-M-T
25	0	J201,J202,J203	Flying Leads	no part		
26	1	J301	Socket 0.050" 7x2/SM	1-01064-119	SAMTEC	FLE-107-01-G-DV-A
27	3	L101,L102,L103	FR43 bead	6-00174-051	FAIR-RITE	2643666611
28	1	L201	1.2 μ 5% 500mA	6-00676-100	API DELEVAN	1210-122J
29	0	MH101,MH102,MH103,MH104	Mounting Hole	no part		
30	2	Q201,Q202,Q203	MMBF4416	3-01324-152	VISHAY	SST4416
31	1	Q204	MMBT2907A	3-00927-150	ON SEMI	MMBT2907ALT1
32	4	Q205,Q206,Q207,Q208	MMBF5460	3-01305-152	FSC	MMBF5460
33	5	R101,R111,R112,R115,R117	100k 5%	4-01527-100	VENKEL	CR1206-8W-104JT
34	1	R102	1.0k	4-01479-100	VENKEL	CR1206-8W-102JT
35	1	R103	210	4-01052-110	VENKEL	TRN55CF-2100TR
36	1	R104	3.9k	4-01493-100	VENKEL	CR1206-8W-392JT
37	1	R105	3.9kx4 D	4-00917-120	BI	BCN164A-392-J7
38	3	R106,R261,R314	4.7k	4-01495-100	VENKEL	CR1206-8W-472JT
39	1	R107	22k	4-01511-100	VENKEL	CR1206-8W-223JT
40	1	R108	10	4-01431-100	VENKEL	CR1206-8W-100JT
41	3	R109,R118,R119	270	4-01465-100	VENKEL	CR1206-8W-271JT
42	5	R110,R120,R121,R227,R262	100 5%	4-01455-100	VENKEL	CR1206-8W-101JT
43	3	R113,R114,R260	10k	4-01503-100	VENKEL	CR1206-8W-103JT
44	1	R116	100kx4 D 5%	4-01704-120	CTS	742C083104J
45	1	R122	150 5%	4-01459-110	VISHAY	CRCW1206151JRT1
46	1	R123	121	4-01029-110	VENKEL	TRN55CF-1210TR
47	1	R124	365	4-01075-110	VENKEL	TRN55CF-3650TR

Item	Qty.	Reference	Part	SRS P/N	Manufacturer	Manf. P/N
48	8	R201,R219,R223,R224,R233, R234,R242,R249	1.00M	4-01405-110	VENKEL	TRN55CF-1004TR
49	2	R202,R203	1.00k 1.0W flameproof	4-00542-000	VISHAY	CPF11K0000FKB14
50	2	R204,R205	200 1%	4-01050-110	VENKEL	TRN55CF-2000TR
51	1	R206	510	4-01472-100	VENKEL	CR1206-8W-511JT
52	8	R207,R210,R211,R212,R239, R246,R253,R258	1.00k	4-01117-110	VENKEL	TRN55CF-1001TR
53	1	R208	280	4-01064-110	VENKEL	TRN55CF-2800TR
54	1	R209	4.02k	4-01175-110	VENKEL	TRN55CF-4021TR
55	1	R213	909	4-01113-110	VENKEL	TRN55CF-9090TR
56	1	R214	14.0k	4-01227-110	VENKEL	TRN55CF-1402TR
57	2	R215,R222	1.000k×2 1ppm/K 0.1%rat	4-01738-122	VISHAY	MPM2001AT
58	1	R216	2.500k×2 1ppm/K 0.1%rat	4-01721-122	VISHAY	MPM5001AW
59	1	R217	604.0 5ppm/K	4-01733-000	VISHAY	PTF56604R00BZBF
60	1	R218	523k	4-01378-110	VENKEL	TRN55CF-5233TR
61	1	R220	49.9k	4-01280-110	VENKEL	TRN55CF-4992TR
62	1	R221	10.0	4-00925-110	VENKEL	TRN55CF-10R0TR
63	1	R225	10.0k	4-01213-110	VENKEL	TRN55CF-1002TR
64	1	R226	2.00k	4-01146-110	VENKEL	TRN55CF-2001TR
65	1	R228	35.7 2W flameproof	4-01735-000	VISHAY	CPF235R700FKB14
66	1	R229	5.1	4-01424-100	VENKEL	CR1206-8W-5R1JT
67	2	R230,R231	13.3 2W flameproof	4-01736-000	VISHAY	CPF213R300FKB14
68	3	R232,R241,R248	365k	4-01363-110	VENKEL	TRN55CF-3653TR
69	1	R235	649k	4-01387-110	VENKEL	TRN55CF-6493TR
70	3	R236,R243,R250	221k	4-01342-110	VENKEL	TRN55CF-2213TR
71	6	R237,R238,R244,R245,R251, R252	2.4M	4-01560-100	VISHAY	CRCW1206245JRT1
72	3	R240,R247,R254	3.01k	4-01163-110	VENKEL	TRN55CF-3011TR
73	1	R255	392	4-01078-110	VENKEL	TRN55CF-3920TR
74	1	R256	732	4-01104-110	VENKEL	TRN55CF-7320TR
75	1	R257	249	4-01059-110	VENKEL	TRN55CF-2490TR
76	1	R259	150k 1%	4-01326-110	VENKEL	TRN55CF-1503TR
77	13	R301,R302,R303,R304,R305, R306,R307,R308,R309,R310, R311,R312,R313	4.7k×4 D	4-00911-120	BI	BCN164A-472-J7
78	2	R315,R316	2.2k	4-01487-100	VENKEL	CR1206-8W-222JT
79	5	S301,S302,S303,S304,S305	B3F-1052	2-00053-000	OMRON	B3F-1052
80	0	TP101	Test Point	no part		

Item	Qty.	Reference	Part	SRS P/N	Manufacturer	Manf. P/N
81	2	U101,U108	74HC14	3-00662-103	PHILIPS	74HC14D
82	1	U102	74HC74	3-00742-103	TI	SN74HC74D
83	2	U103,U104	74HC21	3-01502-103	PHILIPS	74HC21D
84	1	U105	74AC00	3-01405-100	FSC	74AC00SC
85	1	U106	MAX6348 4.4V	3-00903-124	MAXIM	MAX6348UR44-T
86	1	U107	68HC912B32	3-01379-114	FREESCALE	MC68HC912B32CFU8
87	1	U109	LM317L	3-00096-030	ON SEMI	LM317LZ
88	1	U201	AD8510A	3-01318-120	ANALOG	AD8510AR
89	2	U202,U203	LM7121	3-01306-120	NSC	LM7121IM
90	1	U204	MAX5541C	3-01217-171	MAXIM	MAX5541CSA
91	2	U205,U207	OPA2227A	3-01471-120	TI	OPA2227UA
92	1	U206	LTC1452C	3-00652-171	LTC	LTC1452CS8
93	1	U208	THS4032	3-01219-120	TI	THS4032CDGN
94	1	U209	DG419	3-01367-122	VISHAY	DG419DY
95	1	U210	AD5415	3-01171-171	ANALOG	AD5415YRU
96	1	U211	EL2244	3-01300-120	INTERSIL	EL2244CS
97	1	U212	BUF634P	3-01221-120	TI	BUF634P
98	3	U213,U214,U215	LM393	3-00728-121	TI	LM393D
99	1	U216	MAX6225BC	3-00970-123	MAXIM	MAX6225BCSA
100	1	U217	OPA277A	3-01370-120	TI	OPA277UA
101	7	U301,U303,U305,U308,U310, U312,U315	74HC595A	3-00672-103	ON SEMI	MC74HC595ADT
102	2	U302,U309	HDSP-A107	3-01424-061	AVAGO	HDSP-A107
103	6	U304,U306,U307,U311,U313, U314	HDSP-A101	3-00290-061	AVAGO	HDSP-A101
104	5	no designator	Button Cap	0-00996-999	OMRON	B32-1000
105	4	no designator	4-40x1/4 Pan Phil	0-00187-999	ACF	PPM-04C04-0-Z
106	4	no designator	#4 Split Washer	0-00096-999	J&M	4NLOCLZ
107	2	no designator	4-40x3/8 Flat Phil	0-00835-999	ACF	PUM-04C06-0-Z
108	4	no designator	4-40x1/8 Pan Slot	0-00148-999	ACF	SPM-04C02-0-Z
109	4	no designator	4-40x1/8 Pan Phil	0-00515-999	ACF	PPM-04C02-0-Z
110	8	no designator	4-40x1/8 Black Flat Phil	0-00371-999	ACF	PUM-04C03-0-B
111	6	no designator	1.5" 24AWG Uninsulated	0-00772-999	>	>
112	1	no designator	6.5" 22AWG White	0-00436-999	>	>
113	1	no designator	6.5" 22AWG Black	0-00268-999	>	>
114	1	no designator	7.5" 22AWG Red	0-00154-999	>	>
115	1	no designator	7.5" 22AWG Black	0-00161-999	>	>
116	1	no designator	3.0" 22AWG Red	0-00006-999	>	>
117	2	no designator	BNC Insulated	1-00073-256	AMPHENOL	31-10-4052
118	1	no designator	BNC	1-00003-256	TYCO	227169-4
119	1	no designator	Circuit Board	7-01639-999	FAB	SIM983 Circuit Board Rev. D
120	1	no designator	Front Panel	7-01603-999	FAB	SIM983 Front Panel Rev. B
121	1	no designator	Lexan Overlay	7-01605-999	FAB	SIM983 Front Lexan Rev. B
122	1	no designator	Rear Panel	7-01604-999	FAB	SIM983 Rear Panel Rev. A
123	2	no designator	Top/Bottom Bracket	7-00933-999	FAB	SIM Sglw. Bracket Rev. D
124	2	no designator	Module Cover	7-00932-999	FAB	SIM Module Cover Rev. C2
125	4	no designator	Rubber Foot	0-00188-999	MOUSER	5167-202
126	1	no designator	Serial Number Label	9-01545-999	FAB	SIM SN Label Rev. A

5.3 Schematic Diagrams

Circuit schematic diagrams follow this page.

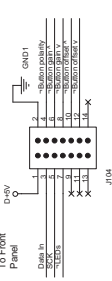
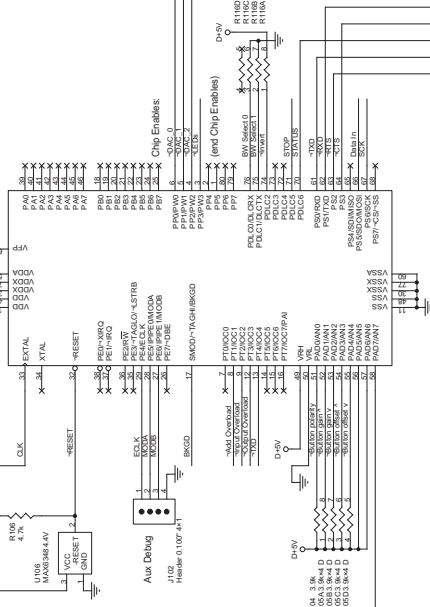
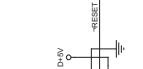
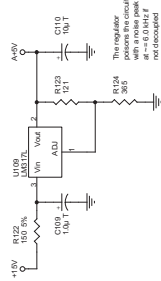
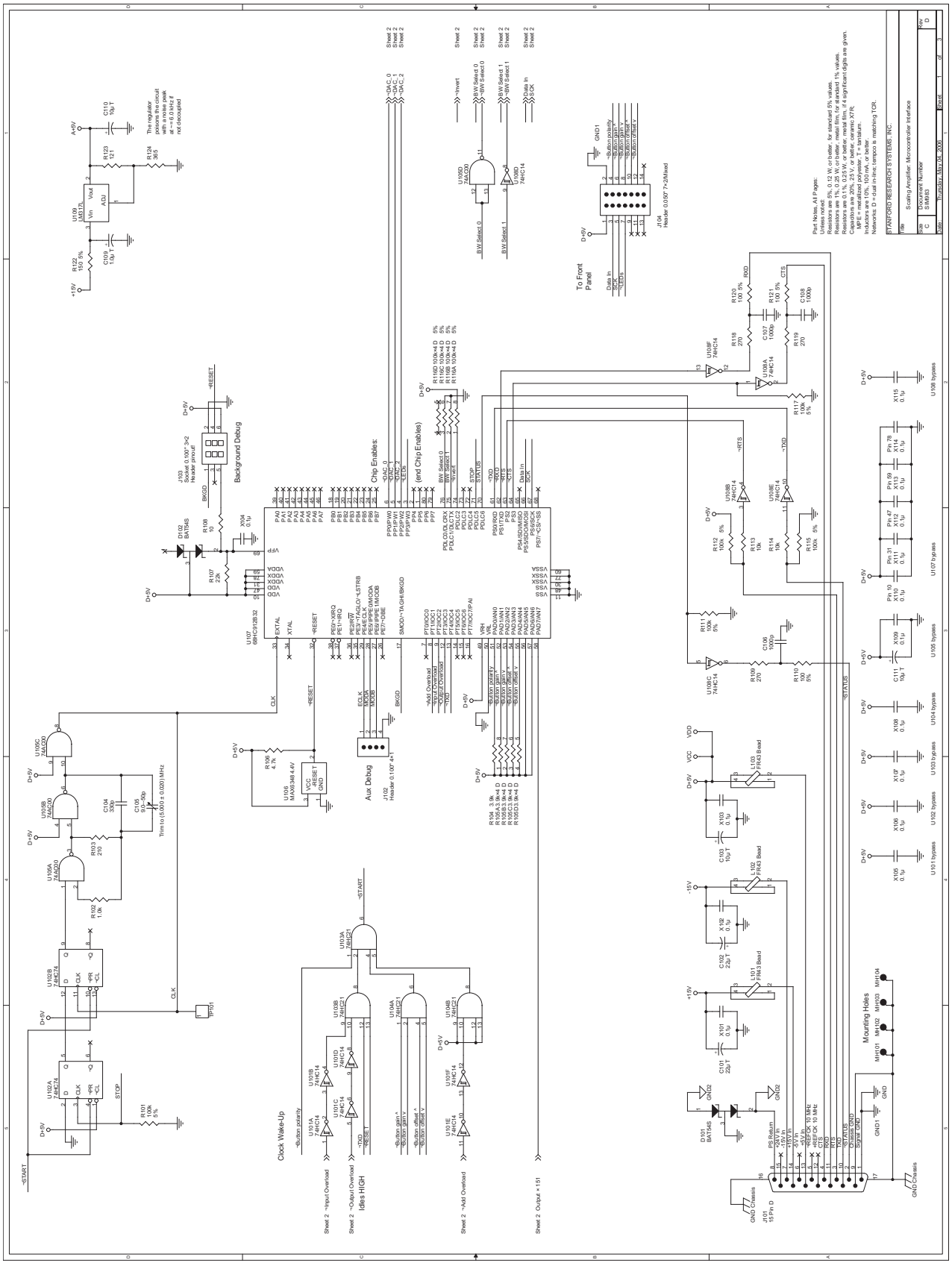

Part Name: All Pages
 Unless noted:
 Resistors are 1% tolerance, 0.1W, unless otherwise noted.
 Resistors are 0.1%, 0.25W, or better, metal film, if a significant figure is given.
 Capacitors are 10% tolerance, unless otherwise noted.
 MFE = metallized polyester; T = tantalum.
 Inductors are 10%, 100mA, or better.
 Dimensions in inches (metric in matching) (mm).
 November 5, 2005 (Initial complete & matching) CSR.

PINFORD RESEARCH SYSTEMS, INC	
Part	Serial Number
Doc	Doc Number
Rev	Rev
Date	Date
Author	Author
Drawn	Drawn
Checked	Checked
Approved	Approved

Clock Wake-Up

Sheet 2 - Input Overload

Sheet 2 - Output Overload

Sheet 2 - High

Sheet 2 - Mid Overload

Sheet 2 Output x151

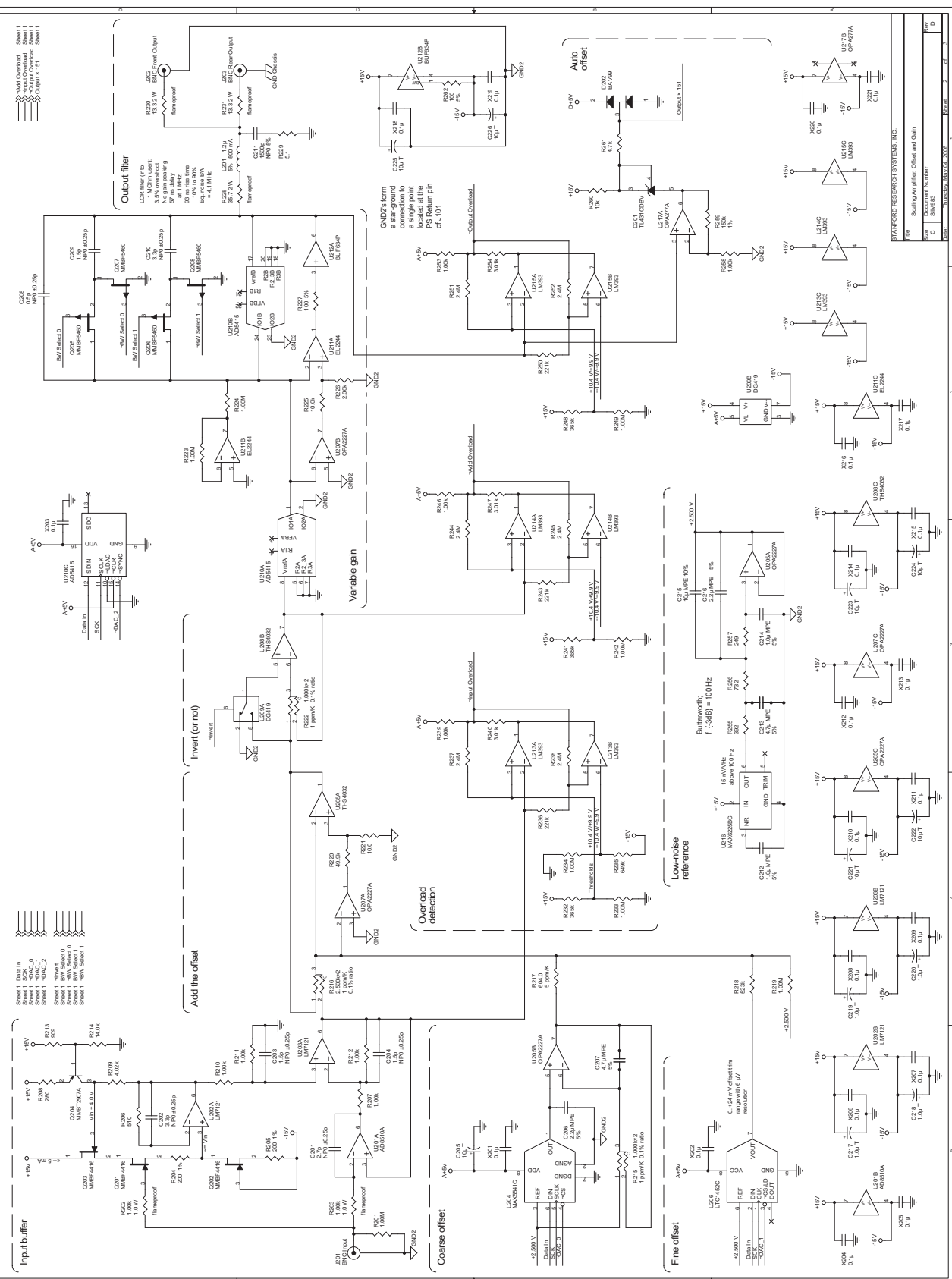

Sheet 1
Sheet 2
Sheet 3
Sheet 4
Sheet 5
Sheet 6
Sheet 7
Sheet 8
Sheet 9
Sheet 10
Sheet 11
Sheet 12

Sheet 1 Data In
Sheet 1 -DAC_0
Sheet 1 -DAC_1
Sheet 1 -DAC_2
Sheet 1 -DAC_3
Sheet 1 -DAC_4
Sheet 1 -DAC_5
Sheet 1 -DAC_6
Sheet 1 -DAC_7
Sheet 1 -DAC_8
Sheet 1 -DAC_9
Sheet 1 -DAC_10
Sheet 1 -DAC_11
Sheet 1 -DAC_12

Sheet 1
Sheet 2
Sheet 3
Sheet 4
Sheet 5
Sheet 6
Sheet 7
Sheet 8
Sheet 9
Sheet 10
Sheet 11
Sheet 12

FINFORD RESEARCH SYSTEMS, INC.
Title: Scaling Amplifier, Offset and Gain
Doc: S-1000-001
Rev: 1.0
Date: 11/11/00

Doc: S-1000-001
Rev: 1.0
Date: 11/11/00

Doc: S-1000-001
Rev: 1.0
Date: 11/11/00

Doc: S-1000-001
Rev: 1.0
Date: 11/11/00

Doc: S-1000-001
Rev: 1.0
Date: 11/11/00

Doc: S-1000-001
Rev: 1.0
Date: 11/11/00

Doc: S-1000-001
Rev: 1.0
Date: 11/11/00

Doc: S-1000-001
Rev: 1.0
Date: 11/11/00

Doc: S-1000-001
Rev: 1.0
Date: 11/11/00

Doc: S-1000-001
Rev: 1.0
Date: 11/11/00

Doc: S-1000-001
Rev: 1.0
Date: 11/11/00

Doc: S-1000-001
Rev: 1.0
Date: 11/11/00

Doc: S-1000-001
Rev: 1.0
Date: 11/11/00

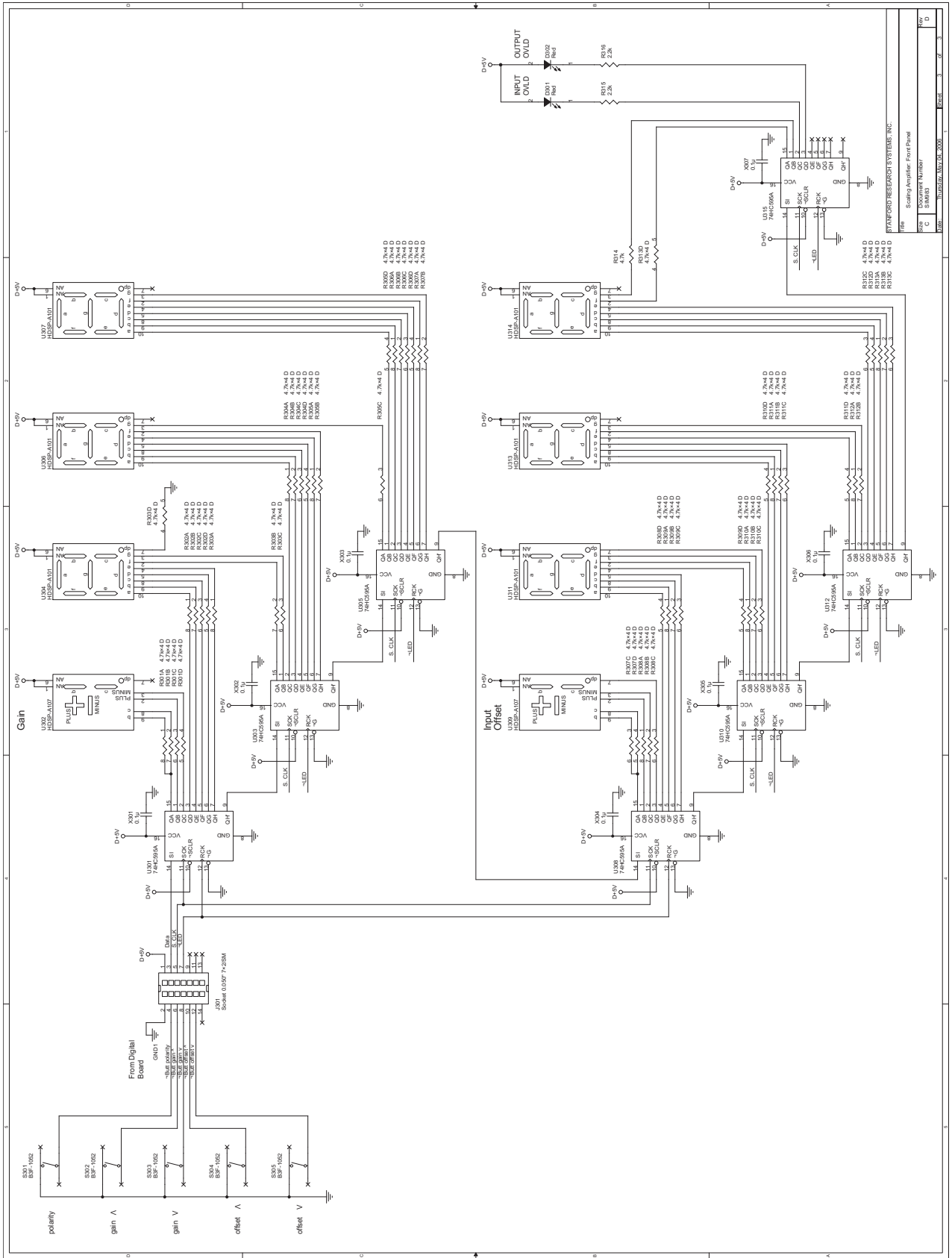

Appendix A Index

- STATUS signal, 1 – 2, 1 – 7, 3 – 12, 13, 3 – 20
- ⟨break⟩ signal, *see* Device Clear
- Accuracy, iii, 4 – 2
 - gain, *see* Gain, accuracy
 - offset, *see* Offset, accuracy
 - verifying at DC, 4 – 2, 4 – 8
- Autocalibration, vii, 1 – 2, 2 – 2, 3, 3 – 11, 3 – 13, 3 – 17, 3 – 21, 4 – 2, 5 – 2, 5 – 6
- Bandwidth, vi, 1 – 2, 2 – 3, 3 – 6, 3 – 10, 11, 4 – 4, 5, 5 – 2, 5 – 5
 - default, 1 – 6, 3 – 11, 3 – 14
- Baud rate, 1 – 9, 3 – 6
- Bias current, vi, 4 – 3, 5 – 2
- Block diagram, 1 – 2
- BNC, iii, vi, vii, 2 – 2
- Buffer
 - input, 3 – 6, 3 – 20–22
 - overflow, 3 – 6, 3 – 22
 - voltage, *see* Input, voltage buffer
 - output, *see* Output queue
 - voltage, *see* Output, voltage buffer
- Button, 3 – 11, 3 – 13, 3 – 21
 - [gain], 1 – 3, 2 – 3, 3 – 13
 - [offset], 1 – 4, 3 – 13
 - [polarity], 1 – 3, 4, 2 – 3, 3 – 13
- Calibration, *see* Factory calibration
- Circuit schematics, *see* Schematic diagrams
- Clock stopping, 1 – 2, 2 – 4, 3 – 10, 3 – 14, 5 – 2
- Command
 - error, 3 – 16, 3 – 21
 - parameters, 3 – 7, 3 – 16
 - separator, 3 – 7
 - terminator, 3 – 6, 7, 3 – 14, 3 – 17
- Compensation, 2 – 3, 4 – 4, 5 – 5
- Console mode, 3 – 6, 3 – 14, 15
- DB–15, 1 – 7, 8, 2 – 2
- DB–9
 - female, 1 – 8
 - male, 1 – 8
- Default configuration, *see* Reset
- Device Clear, 3 – 6, 3 – 15, 3 – 17, 3 – 22
- Device error, 3 – 16, 3 – 21
- Dimensions, vii
- Distortion, *see* Total harmonic distortion
- DS345, 4 – 4
- Error
 - budget, 4 – 2
 - command, *see* Command, error
- Execution error, 3 – 15, 3 – 21
- Factory calibration, 4 – 2, 3
- Firmware revision, 3 – 15
- Flow control, 1 – 9, 3 – 6, 3 – 17
- Front panel, 1 – 2, 3, 2 – 3, 4, 3 – 11
 - operation, 1 – 3
- Full duplex, *see* Console mode
- Gain, iii, vi, 1 – 2, 3, 1 – 6, 2 – 2, 3, 3 – 6, 3 – 10, 11, 5 – 4
 - accuracy, vi, 2 – 3, 4 – 3
 - button, *see* Button, [gain]
 - default, 1 – 4, 1 – 6, 3 – 10, 3 – 14
 - polarity, *see* Polarity
 - resetting, 1 – 4, 3 – 13
 - resolution, vi, 1 – 3, 5 – 4
 - stability, vi, 4 – 3, 5 – 4
- Gain-bandwidth product, vi, vii, 1 – 2, 2 – 3, 3 – 11, 4 – 4, 5 – 5
- Gain stage, 2 – 3, 5 – 2, 5 – 4
- General information, iii
- Ground, 1 – 7, 8, 2 – 2, 5 – 2
 - analog, 1 – 8, 2 – 2, 5 – 2
 - chassis, 1 – 7, 8, 2 – 2
 - Earth, 2 – 2
 - power, 1 – 8, 2 – 2
 - star, 5 – 2
- Help, 3 – 9

- Input
- capacitance, vi
 - connector, vi, 2 - 2
 - coupling, vi
 - overload, *see* Overload, input
 - resistance, vi, 4 - 3
 - voltage, iii, 1 - 8
 - limits, vi, vii, 1 - 5, 5 - 2, 5 - 4
 - voltage buffer, 4 - 5, 5 - 2
- Interface
- direct, 1 - 7
 - cable, 1 - 8
 - remote, *see* Remote interface
 - SIM, *see* SIM interface
- Inverter, 5 - 2, 5 - 4
- Mainframe, *see* SIM900
- Microcontroller, 5 - 2
- Noise, vi, 4 - 6, 5 - 3-5
 - dependence on gain, 4 - 6, 5 - 5
 - verifying, 4 - 6, 4 - 8
- Non-volatile settings, 1 - 6, 3 - 6
- Notation, v, 3 - 6, 3 - 8
- Null modem, 1 - 8
- Offset, iii, vi, 1 - 2-4, 1 - 6, 3 - 6, 3 - 10, 5 - 3
 - accuracy, vi, 1 - 2, 1 - 4, 2 - 2, 4 - 3, 5 - 3
 - button, *see* Button, [offset]
 - default, 1 - 4, 1 - 6, 3 - 10, 3 - 14
 - resetting, 1 - 4, 3 - 13
 - resolution, vi, 1 - 4
 - settling time, vi, 5 - 3
 - stability, vi, 4 - 3, 5 - 2-4
 - voltage limits, vi, 1 - 4
- Offset generator, 5 - 2, 3
- Output
- connector
 - front, vi, 2 - 2
 - rear, vi, 2 - 2
 - current, vi, 1 - 2, 2 - 2
 - filter, 5 - 2, 5 - 5
 - maximum load, 1 - 2, 2 - 2, 5 - 5
 - overload, *see* Overload, output
 - resistance, vi, 2 - 2
 - voltage, iii, 1 - 8
 - limits, vi, 1 - 5, 2 - 3, 5 - 5
 - maximum undistorted sine wave, 1 - 2, 2 - 3
 - voltage buffer, 5 - 5
- Output queue, 3 - 6, 3 - 15, 3 - 21, 22
- Overload, 1 - 2, 1 - 4, 2 - 4, 3 - 14, 4 - 2
 - input, vii, 1 - 2, 1 - 5, 3 - 14, 3 - 22, 5 - 2
 - OVL indicator, 1 - 2, 1 - 5, 5 - 6
 - input plus offset, vii, 1 - 5, 3 - 14, 3 - 23, 5 - 4
 - output, vii, 1 - 2, 1 - 5, 3 - 14, 3 - 23, 5 - 5
 - OVL indicator, 1 - 2, 1 - 5, 5 - 6
- Overshoot, 4 - 4, 5 - 5
- Parity, 1 - 9, 3 - 6, 3 - 17, 3 - 21
- Parts, 5 - 6
- Polarity, vi, 1 - 2-4
 - button, *see* Button, [polarity]
- Power
- analog, 5 - 2
 - ground, *see* Ground, power
 - requirements, vi, 1 - 7, 8
- Power-on, 1 - 6, 2 - 4, 3 - 6, 3 - 13, 3 - 15, 3 - 17, 3 - 20-23
- Preparation for use, iii
- Query command, 3 - 7, 3 - 16, 3 - 20
- Rear panel, 1 - 2, 3
- Registers, *see* Status, registers
- Remote interface, vii, 1 - 2, 1 - 6, 2 - 4, 3 - 1, 3 - 6, 3 - 9, 3 - 14
 - data format, 3 - 10, 11
- Reset, 1 - 6, 2 - 3, 3 - 13-15, 3 - 17
- Rise time, 4 - 4
- RS-232, 1 - 2, 1 - 8, 3 - 6, 3 - 17, 3 - 21, 22, 5 - 2
 - settings, 1 - 9, 3 - 17
- Safety, iii
- Schematic diagrams, 5 - 9
- Self-test, 3 - 15
- Serial interface, *see* RS-232
- Serial number, 3 - 15
- Service, iii, 4 - 3
- Set command, 3 - 7, 3 - 16
- Settling time, *see* Bandwidth
 - offset, *see* Offset, settling time

SIM900, iii, 1 - 2, 1 - 7, 8, 2 - 2, 3 - 6
SIM928, 4 - 2
SIM965, 4 - 6
SIM970, 4 - 2, 3
SIM interface, vii, 1 - 7, 3 - 20
 connector, 1 - 7, 2 - 2, 5 - 2
Slew rate, vi, 2 - 3, 4 - 5, 5 - 2
Specifications, vi
SR785, 4 - 4, 4 - 6
Stability
 gain, *see* Gain, stability
 offset, *see* Offset, stability
Status, 3 - 11, 3 - 19
 registers, 3 - 11, 3 - 19
 CESE, 3 - 12, 3 - 22
 CESR, 3 - 6, 3 - 12, 3 - 20-22
 ESE, 3 - 12, 3 - 14, 3 - 21
 ESR, 3 - 6, 3 - 12, 3 - 15, 3 - 20
 OLSB, 3 - 20
 OLSE, 3 - 13, 14, 3 - 23
 OLSR, 3 - 13, 14, 3 - 22, 23
 SB, 3 - 12, 3 - 20-23
 SRE, 3 - 12, 3 - 14, 3 - 20
Step response, 4 - 4, 5, 5 - 5
Sticky bits, 3 - 19, 20
Summing amplifier, 5 - 2, 3

Temperature, vi, 2 - 2, 4 - 2
Token, 3 - 7, 3 - 15, 16
 mode, 3 - 14, 3 - 17
Total harmonic distortion (THD), vi, 4 - 6

Warmup, vii, 2 - 2, 4 - 2
Weight, vii

Distribution in the UK & Ireland



**Characterisation,
Measurement &
Analysis**

Lambda Photometrics Limited

Lambda House Batford Mill
Harpenden Herts AL5 5BZ

United Kingdom

E: info@lambdaphoto.co.uk

W: www.lambdaphoto.co.uk

T: +44 (0)1582 764334

F: +44 (0)1582 712084