

# **Nutrislice Response for KEDC's RFP-Nutrition-DSS-2018**



**Tab 1**

# **Cover Letter & Executive Summary**

To the Kentucky Educational Development Center (KEDC):

Nutrislice presents this proposal with detailed information about our software, services and programs, which fully meet the requirements of your RFP. Nutrislice consists of three products: Digital Menus, Signage, and Ordering. We look forward to the opportunity to continuing a partnership with Kentucky Education Development Corporation (KEDC) to improve the digital experience Kentucky School Districts' parents and students have. In this proposal you will see detailed information how our products, menus, signage, and ordering, meet the requirements and provide the best option for Kentucky Education Development Corporation.

For over 7 years, Nutrislice has focused on building an innovative software platform that helps programs, like those in Kentucky, communicate and grow with their customers. In that time we've seen organization gain greater trust, brand loyalty, awareness, sales, participation, and operational efficiency. We are the first company to provide interactive digital menus via both web and a mobile app. In this time we've grown to be the leader in foodservice marketing technology and are trusted by more than 1,800 school districts to be the way they communicate with their more than 10 million enrolled students. They're able to effectively do this through the following products:

#### **Nutrislice Digital Menus**

Nutrislice Menus is a powerful platform that helps school nutrition programs, like those in Kentucky, market their programs. Through Nutrislice, school menus can be published across multiple channels and accessed by parents and students anywhere at anytime.

#### **Nutrislice Digital Signage**

Our turnkey digital signage enables districts to market to their students right up to the point of sale. With automated menu options, restaurant-quality imagery, design templates, customizable options, and engaging content districts have the ability to move through the cafeteria lines in a fun and educational way. We provide clients with the option to either use our software on existing hardware or purchase turnkey hardware with installation packages to ensure an easy start!

#### **Nutrislice Digital Ordering**

With Nutrislice Ordering programs are able to help clients provide their parents and students with an innovative experience they've become accustomed to in major restaurants. Through a seamless extension of the Nutrislice menus software, students and parents can place orders days in advance, and when it comes time to pick up the meal, skip the line and go directly to picking up the pre-order pickup line. The results allow for more time to eat and socialize.

In this proposal you will find that Nutrislice meets or exceeds all of the requirements outlined for this RFP. We are looking forward to opportunity to continue our relationship with the Kentucky Education Development Corporation and working with more Kentucky school districts.

**Tab 2**

# **Digital Menus**

# 1. Menu Display Options

## a. Powerful, interactive online menus (including an available allergen filter for parents whose children have food allergies)

Nutrislice provides interactive online and mobile menus that allow parents and students nationwide the ability to see what their school is offering and how it fits into their dietary and allergen needs through interactive filters and highlights.

## b. Innovative smartphone menus that work across all platforms

Nutrislice menus are available via the free mobile app which is available in both the Google Play Store and the Apple App Store as well as any web browser.

## c. Convenient email subscription options for parents

Nutrislice provides a quick and easy way for foodservice programs to get the word out about their menus through email subscription. To do this programs simply put a subscribe button, pre-formatted within the Nutrislice admin, on their digital menus and then on a monthly basis they have the ability to go in and choose to send an email automatically.

## d. PDF menus for customer printing

Customers can easily print menus from their mobile device or computer. Parents and students can personalize their menu before printing. Nutrislice print menus include functionality that allows menus to print in a visually appealing format while adapting to their page proportions. The menu is highly configurable to the preferences of the person printing the menu by allowing them to include allergen filters and highlights and nutrition information, change sizes, exclude or include graphics, save ink, and more!

**Location**  
Lincoln Elementary

**Menu**  
Lunch

**Language**  
English

View By: **Week** | Month

Orientation: **Portrait** | Landscape

**Print**

**Print Settings (Optional)**

Save Ink (Remove graphics and color)  
 OFF

Hide Sidebar  
 OFF

Font Size: Normal

Fit to one page

**Add Nutrition Info**  
Choose Up to 3

Calories

Carbohydrates

Fiber

Protein

Total Fat

Saturated Fat

Sugar

Cholesterol

Sodium

Calcium

© 2018 Nutris

d Proprietary

## 2. Menus Include:

### a. Customer-Friendly Names

Nutrislice digital menus allow you to name your foods to anything you desire, including customer-friendly names. As you onboard with the Client Success Team they will include menu-ready names in your import, saving you the time and hassle of changing each one. If you have any changes you want made to them or already have your own in a spreadsheet, it can easily be updated with a quick import or change in the Admin.

### b. Images

We want to empower you to have the best and most visually appealing menus right away, which is why we offer an extensive library of foods which can automatically be assigned using our image smart match. You can at any time add in your own images by simply uploading the desired image to that food within Admin.

### c. Descriptions

Just like with images, we offer a large resource of ready-to-use descriptions. If you would like to add in your own that is possible as well be simply updating the information tied to the food profile in Admin.

### d. Basic Nutritional Information (calories, carbs, sodium, etc.)

Each food you keep within Nutrislice is able to hold a wealth of information to display on the nutrition label parents and students see on the front-end. This information includes; serving sizes, ingredients, subfoods, calories, fats, cholesterol, sodium, total carbohydrates, dietary fiber, sugars, protein, vitamins, calcium, iron, and potassium. You can choose to show as many of these items or as few of these as you desire.

### e. Allergen Information (including the 8 most-common allergens that account for ~90% of food allergies)

Nutrislice allows you to provide your customers with detailed information on allergies, special diets, and any other special food icon. You can create custom allergen and special diet groups to allow parents and students to identify and filter out menu items that don't meet their needs.

With Nutrislice you can go beyond the Big 8 allergens and add more options from our library of more than 50 icons. If there is an allergens we don't have you can simply upload your own custom icons to ensure you are meeting all of your students' needs.

The Nutrislice Admin includes an approval workflow, so foods never appear to be allergen-free when they have no been coded yet.

With Nutrislice you will have:

- Infinite icon capabilities
- The ability to highlight special diets like gluten-free, vegan, and vegetarian
- The capability to filter menu items based on allergens
- Options to add promotional icons like 'Farm to School' or 'Chef Special' to showcase your program

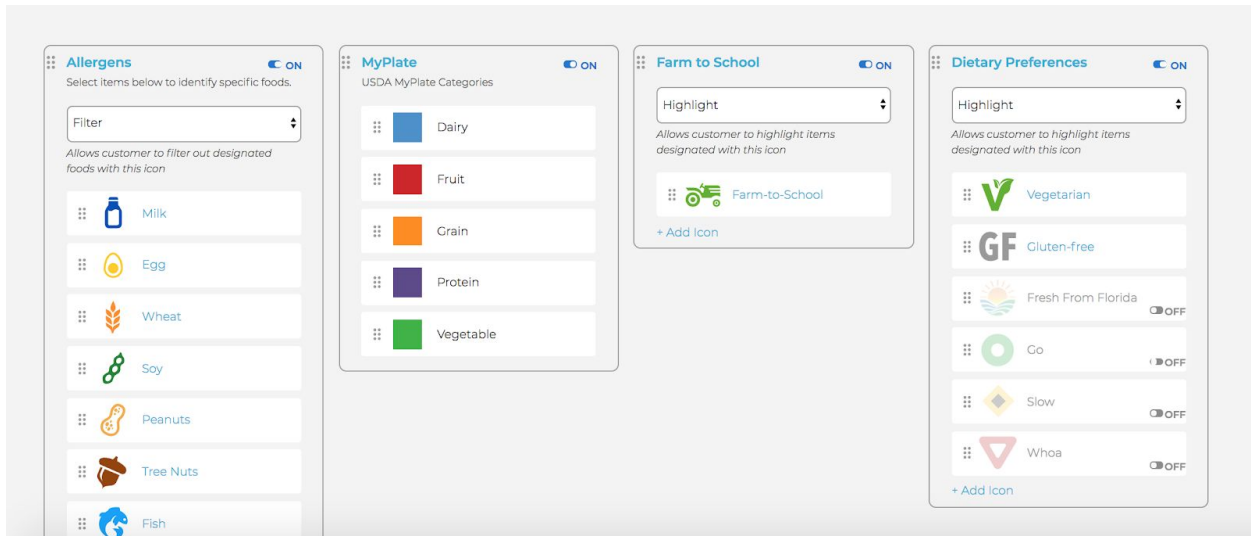

**f. Ingredients List (including the ability to include multiple or nested ingredient list(s)).**

With Nutrislice you can add in as many or as few ingredients as you would like. Nutrislice also allows you to pull together foods already in your system to make up subfoods, for example you could have cereal as a food and then pull in subfoods of milk and the dry cereal to roll-up into “cereal”.

**3. Nutritional Data Import Must Be Included**

You’re able to easily import your nutrition information into our software within minutes, by uploading a detailed spreadsheet that you can pull out of your nutrient analysis system. Our Client Success Team is here to support you in your ongoing efforts as well.

**4. Lifetime Feature Upgrades**

In your partnership with Nutrislice you will continue to receive updates to your system. Large and small you will receive updates, upgrades, and improvements that are made to the software.

**5. Background Images and Video Library**

Nutrislice offers an extensive library to provide clients with all the materials they need to have a robust and visually appealing Nutrislice site. From food images to advertising pieces it is all ready for you to use once you’re with Nutrislice.

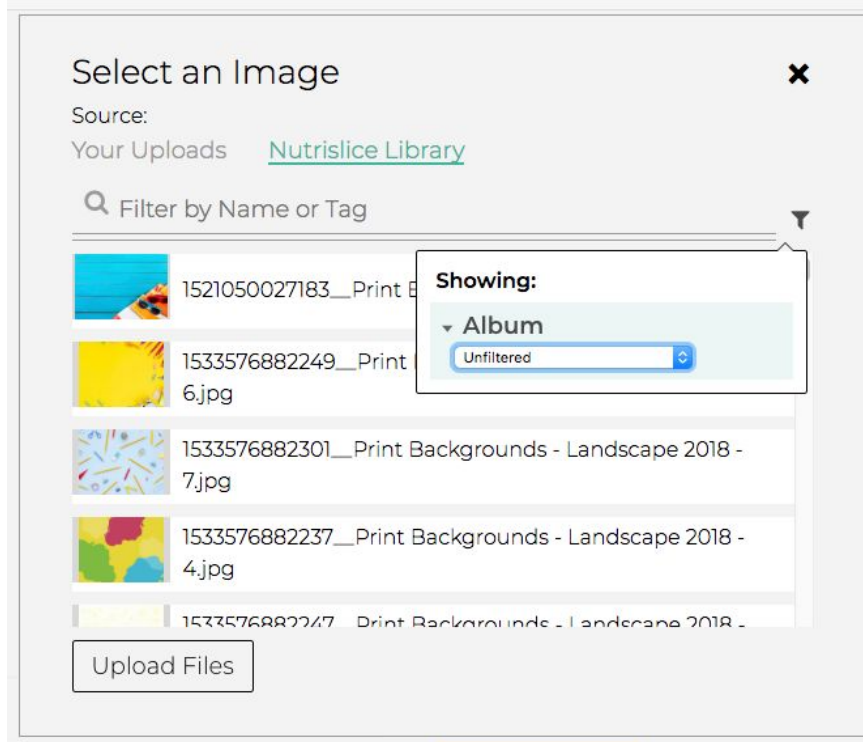

## 6. The System Must Support Cycle Menus and Allow Users to Copy and Reuse Menu(s)

With Nutrislice digital menus you can easily upload cycle menus and set them to run as far into the future as you would like. At anytime you may clone published or unpublished menus for use. If you wish to not clone the entire menu you may also copy certain days using a quick import feature and import it elsewhere, including other menus.

## 7. Menus Created Must be Assignable to Multiple Schools

Easily assign out your menus to as many or as few schools as you would like, at anytime. You can quickly choose which locations you would like to assign to the menu within the menu builder. Locations can be assigned to a “location group” which allows you to categorize your sites so that when assigning menus, marketing, and more you can choose a while group rather than each individual site.

## 8. Menu Changes are Updated Instantly and Available On All Menus

With the click of “save” your menus are instantly updated across all platforms including, mobile, web, Alexa, and digital signage.



## 9. The Provider Must Host All Websites, Databases, and Applications Associated with the Solution in a Secure Location and Provide Off-Site Redundancy

All Nutrislice websites, databases, and applications associated with the solutions are hosted in a secure location and provide off-site redundancy.

## 10. The Provider Must Maintain All Websites, Databases and Application Associated with the Solution Including Providing All Required Patches and Software Upgrades for the Life of the Contract

During the life of the contract Nutrislice will continually release updates, upgrades, and fixes for menus. For any issues that you experience and report to our team we will get our Development Team working on the issue and communicate the progress along to you.

## 11. The Supplier Must Provide Training to Assist Staff

Nutrislice has extensive training experience with school districts of all sizes and our software allows us to onboard and support new districts in a timely manner. We focus on reducing the level of effort required to onboard and maintain our software, which allows us to be confident in our ability to get districts up and running in a short turn around.

We provide comprehensive education, training, and mentoring to ensure our clients are prepared with the skills needed to use and maintain the software. Clients are provided with one-on-one trainings, webinars, user guides, as well as recorded training accessible at anytime through a client knowledge base.

The Nutrislice Client Success Team is available from 7:00am - 5:00pm CST to answer any questions, assist with needs, and troubleshoot problems that arise to ensure the best experience and success for clients.



## **12.The Provider Must Perform the Initial Account Set-Up**

As you get started with Nutrislice the Client Success Team begins to build your Nutrislice site including importing your menu information, uploading your district imagery to your site, and setting you up for ease and success!

## **13.The Provider Must Offer an Annual Report Card. The Report Card Should be a Private Analysis of How Effectively Each Member Uses the Tool to Communicate with Customers and Suggestions on how to Improve Menu Communication**

Each account is assigned an Account Manager who will provide evaluation of the site. Our Nutrislice Admin offers a robust analytics tool which can provide insights as to how your Nutrislice site is doing and what areas of improvement there are and what progress has been made. Clients can request to have a walk through of admin and talk through ways to address the analytics and improving them.

Account Managers will have a yearly review in which they will talk through how things are proceeding and what goals you may have.

**Tab 3**

# **Digital Signage**

## 14. Digital Signage Display Minimum Requirements

**a. Software must be compatible with Microsoft Windows 10 Professional, Mac, Chrome OS, Android and IOS**

Nutrislice is a cloud-based system which allows for it to be accessed on the internet via any operating system using FireFox, Internet Explorer, Google Chrome, Safari, and more.

**b. Minimum 43” display (include optional upgrades for larger screen sizes)**

The Philips TVs that Nutrislice offers range from a minimum of 43” and go as large as 65”.

**c. Minimum 3 year hardware warranty**

With the Philips displays Nutrislice offers it includes a 3 year advanced warranty.

**d. Commercial Grade**

Nutrislice offers the D-Line Display by Philips which is a commercial grade display with a 24/7 duty cycle.

**e. 1920 x 1080 resolution**

The Philips displays we recommend and offer a panel resolution of 1920 x 1080 to ensure a clear viewing experience.

**f. Supports HDMI or DisplayPort**

The Philips D-Lines displays support both HDMI and DisplayPort options.

**g. Wall mounting hardware to be installed at each site**

The display have the option to be purchased in kits which include a standard tilt mount (upgradeable to full motion or ceiling mount), all necessary cables, and a lock. For installation we use local installers through a trusted national network of technicians that has partnered with Nutrislice.

## 15. Media Player Requirements (Wired or Wireless)

**a. Remote Management Software (Windows 10, Mac OS)**

Nutrislice displays are configured with a remote management system to provide remote support for each screen. System online/offline status and player reboot capability is within the Nutrislice administration site, accessible through any network on any operating system. Through an additional remote management system we are able to get real-time screenshots, change inputs, set display on/off on a schedule, set volume, and diagnose system health.

**b. Configured for Each Location**

Nutrislice allows you to configure each location separately with set up and automation specific to that location. This allows you to decrease the

amount of unique content you need to create. Screens will automatically use menus, color schemes, and logos assigned to their school. Items such as color schemes can be set from a location level down to a screen level. Each screen is set up to be a standalone unit which allows you to seamlessly play unique content on multiple screens in the same location.

**c. Plug and Play**

In Nutrislice digital signage we have a plug-and-play approach. You have the ability to set up your presentations to pull each day's menu without any effort on the user's side. We offer a wide variety of digital signage templates where within a matter of minutes you can upload your menu content and have it running on your screens. We believe in digital signage that has an ease of low-maintenance, but with a flexibility to allow you to do what you want and make changes whenever you want.

**Tab 4**

# **Digital Ordering**

## 16. Digital Online Ordering Requirements

### a. Integrates with menu software

Online ordering is a direct pairing and integration with our digital menus. You can easily make any menu in your system orderable by selecting a box turning on that feature.

### b. Uses menus in the following formats:

#### i. Interactive online menus (including an available allergen filter for parents whose children have food allergies)

Our menus allow parents and students to interact with them in a number of ways. They have the ability to filter or highlight items to see what meets their dietary needs and preferences, as well as provide feedback based on each item by rating them or leaving comments. Parents and students are also able to subscribe for emails for menu updates, track carbohydrates by viewing the report, and accessing resources the district chooses to link on the menu site.

#### ii. Smartphone menus that work across all platforms

Nutrislice Menus are available in the Nutrislice app available in both the Apple App Store and Google Play Store.

### c. Support real time menu changes

Just like with non-orderable menus, once a change has been made in the administrative side it automatically reflects that on the mobile app and web menus. Parents and students will always be up-to-date for their ordering options.

### d. Operating hour customization

As you create your ordering settings in the Nutrislice admin you're able to tailor your settings to fit each location's needs. In the Ordering Settings section you're able to adjust serving days and hours by day. This area also allows you to set cut-off times and number of days in advance you're able to order.

### e. Order Management

With Nutrislice Ordering you will be able to see and manage all of your orders through our Order Queue. This area in our administrative system includes filters, reports, and status updates that allow you to know exactly what is going on. In this area you're able to print tickets, see the order status, learn details about what was ordered, and more.

Order Queue

Filtered results: 60 out of 60 Orders [Clear Filters](#) More [Refresh \(0\)](#)

Search Order Queue Submitted  In Progress  Ready  Picked Up  Canceled  Rejected  All  Filters

Previous  of 1 Next

| Location      | Status      | Submitted        | Ready By                  | Confirmation | Payment Type  | Customer                   | Order Type | Actions |
|---------------|-------------|------------------|---------------------------|--------------|---------------|----------------------------|------------|---------|
| McKinley High | In Progress | 6/07/18 7:19 am  | 1st-lunch<br>(06/07/2018) | 384763782    | Pay at Pickup | Kyle Swikoski<br>(123456a) | Pick Up    |         |
| McKinley High | Picked Up   | 6/07/18 8:07 am  | 1st-lunch<br>(06/07/2018) | 264128589    | Pay at Pickup | Kyle Swikoski<br>(123456a) | Pick Up    |         |
| McKinley High | Picked Up   | 6/11/18 4:05 pm  | 1st-lunch<br>(06/12/2018) | 203778886    | Pay at Pickup | Kyle Swikoski<br>(123456a) | Pick Up    |         |
| McKinley High | Canceled    | 6/12/18 3:52 pm  | 1st-lunch<br>(06/13/2018) | 588242177    | Pay at Pickup | Parke Hunter<br>(12345)    | Pick Up    |         |
| McKinley High | Picked Up   | 6/18/18 10:12 am | 1st-lunch<br>(06/19/2018) | 060937376    | Pay at Pickup | Pat Stephens<br>(12345)    | Pick Up    |         |
| McKinley High | Submitted   | 7/02/18 9:17 am  | 2nd-lunch<br>(07/03/2018) | 250524685    | Pay at Pickup | Pat Stephens<br>(12345)    | Pick Up    |         |

## f. Secure payment options

### i. Point of Sale integration

Nutrislice has integrations with Heartland MCS Newton POS and Lunchtime. We are open to integrating with other partners as well and have a great working relationship with other POS providers. The Nutrislice platform is built in a way to easily integrate with available APIs from any provider.

### ii. Prepaid accounts for students

Nutrislice has the ability to integrate with POS and student account providers to process payments via Nutrislice Ordering. During the order process, accounts will be checked to see if they have sufficient funds, but the actual amount of funds will not be shown. Reimbursable meals prices can be adjusted based on the student's F/R status, as provided by the POS or other integration.

### iii. Credit Cards

Districts have the ability to allow orders to be paid for via credit card. Credit cards are available for set-up via a processing agreement with Heartland Payment Systems and upcoming, Worldpay.

### iii. Pay at Pickup option

Nutrislice allows for you to set the payment options you would like to be made available including, Pay at Pickup. With this option the flow of how to execute this can be done in a number of ways depending on the district's preference.

## 17. The provider must host all websites, database, and applications associated with the solution in a secure location and provide off-site redundancy.

All Nutrislice websites, databases, and applications associated with the solutions are hosted in a secure location and provide off-site redundancy.



**18. The provider must maintain all websites, databases, and applications associated with the solution including providing all required patches and software upgrades for the life of the contract.**

Nutrislice continually releases updates, upgrades, and fixes. If there are issues with the websites and programs associated with the solution we will report the issues to our development team who will then produce a fix for that issue.

**19. The supplier must provide training to assist staff.**

As with Nutrislice menus and signage, our Client Success Team is there every step of the way with you when launching ordering. Our team trains you on the software and works with you to set up ordering in the way that works best for your scenario. After training is complete you will have access to supplemental documents and recording on using the program.

**20. The provider must perform the initial account set-up.**

As a part of your onboarding process with Nutrislice Ordering our Client Success Team gets to building your admin to accommodate those changes including, turning on the controls necessary to make it live, creating the initial needs for ordering settings, and more.

**21. Software must be compatible with Microsoft Windows 10 Professional, Mac, Chrome OS, and Android and IOS.**

Nutrislice is setup as a cloud-based software system so that you will be able to access both the administrative site, all your information, and the front-end of your system from anywhere, including, all operating systems and web browsers.

**22. Lifetime feature upgrades.**

With all of our products, including ordering, you will receive upgrades and updates, large and small, as they're released.

**23. Minimum 3 year hardware warranty.**

The hardware that we use for ordering are two ticket printer options, a high speed ticket printer and a self-stick ticket printer. When ordering these with Nutrislice we include a 3 year warranty.

**Tab 5**

**References,  
Support, &  
Professional  
Development**

## 24. Provide three references from Kentucky School Districts

| Contact                                | Kentucky District             | Information  |
|--|-------------------------------|--|
| Wendy Young - Assistant Director       | Fayette County Public Schools | (859) 381.3846<br><a href="mailto:wendy.young2@fayette.kyschools.us">wendy.young2@fayette.kyschools.us</a>         |
| Josey Crew - Director of Food Services | Hardin County Schools         | (270) 769.8877<br><a href="mailto:josey.crew@hardin.kyschools.us">josey.crew@hardin.kyschools.us</a>               |
| Julia Bauscher - Director              | Jefferson County Schools      | (502) 485.3186<br><a href="mailto:julia.bauscher@jefferson.kyschools.us">julia.bauscher@jefferson.kyschools.us</a> |

## 25. Describe technical support guidelines and procedures.

Our Client Success Team provides clients with technical support in three ways; phone, chat, and email. Our team offers both phone and chat support from 7:00am-5:00pm CT. Outside of these hours we provide a knowledge base which includes an extensive amount of documents and videos to help guide issues or questions you may be having.

## 26. Explain professional development and training offerings including delivery method, frequency, cost, etc.

### Training

We offer both group and personalized training sessions for our clients. Clients have the opportunity to attend webinars, have a screen-share with a Client Success Manager, or review other training documentation such as videos and user-guides.

### Professional Development

Nutrislice believes in providing clients with continuing information to grow professionally which is why we offer free monthly webinars on industry trends. We will send out communications in regards to the webinars and their topics so that clients may sign up and attend. Our Account Management Team is also available to talk through new ways to implement marketing tactics and coaching.

# Tab 8

# Pricing

## Digital Menus Pricing

| Enrollment Low | Enrollment High | Subscription List Price | KEDC Special Subscription Pricing | Set-up List Price | KEDC Special Set-up Pricing |
|----------------|-----------------|-------------------------|-----------------------------------|-------------------|-----------------------------|
| 0              | 1,000           | \$1,020                 | \$918                             | \$1,000           | \$750                       |
| 1,001          | 2,000           | \$1,380                 | \$1,242                           | \$1,000           | \$750                       |
| 2,001          | 3,000           | \$2,100                 | \$1,890                           | \$1,000           | \$750                       |
| 3,001          | 4,000           | \$2,340                 | \$2,106                           | \$1,000           | \$750                       |
| 4,001          | 5,000           | \$2,940                 | \$2,646                           | \$1,000           | \$750                       |
| 5,001          | 7,500           | \$3,540                 | \$3,186                           | \$1,000           | \$750                       |
| 7,501          | 10,000          | \$4,500                 | \$4,050                           | \$1,000           | \$750                       |
| 10,001         | 15,000          | \$5,340                 | \$4,806                           | \$1,500           | \$1,125                     |
| 15,001         | 20,000          | \$7,140                 | \$6,426                           | \$3,000           | \$2,250                     |
| 20,001         | 30,000          | \$10,140                | \$9,126                           | \$3,500           | \$2,625                     |
| 30,001         | 40,000          | \$14,340                | \$12,906                          | \$4,500           | \$3,375                     |
| 40,001         | 50,000          | \$17,940                | \$16,146                          | \$6,500           | \$4,875                     |
| 50,001         | 60,000          | \$22,740                | \$20,466                          | \$7,500           | \$5,625                     |
| 60,001         | 70,000          | \$26,340                | \$23,706                          | \$8,500           | \$6,375                     |
| 70,001         | 80,000          | \$32,340                | \$29,106                          | \$9,500           | \$7,125                     |
| 80,001         | 90,000          | \$35,940                | \$32,346                          | \$10,500          | \$7,875                     |
| 90,001         | 100,000         | \$41,940                | \$37,746                          | \$11,500          | \$8,625                     |
| 100,001        | 150,000         | \$47,340                | \$42,606                          | \$12,500          | \$9,375                     |

## Digital Signage Pricing

| Subscription Per-Screen | Special KEDC Subscription Per-Screen Pricing | Per-Screen Onboarding |
|-------------------------|--|-----------------------|
| \$648                   | \$480  | \$200                 |

## Digital Signage Hardware

| Philips D-Line Size       | Includes  | Pricing |
|---------------------------|---|---------|
| 43" Indoor Display Bundle | Commercial Grade Display, Shipping, Display Mounting Hardware (tilt mount), Accessories, Installation | \$1,599 |
| 49" Indoor Display Bundle | Commercial Grade Display, Shipping, Display Mounting Hardware (tilt mount), Accessories, Installation | \$1,849 |
| 55" Indoor Display Bundle | Commercial Grade Display, Shipping, Display Mounting Hardware (tilt mount), Accessories, Installation | \$2,199 |
| 65" Indoor Display Bundle | Commercial Grade Display, Shipping, Display Mounting Hardware (tilt mount), Accessories, Installation | \$3,249 |

*This pricing represents commercial grade display, shipping, display mounting hardware*

(tilt mount), accessories, installation, Nutrislice can work with individual KEDC districts for other pricing options.

### Digital Signage Other Hardware Options

| Item  | Included  | Pricing |
|---|---|---------|
| Pre-Configured Chromebox Media Player (not installed) | Chromebox, Configuration, Accessories, Shipping, and Google EDU license | \$399   |

*For existing compatible displays*

### Digital Ordering Pricing

| Standard Subscription | KEDC Special Subscription Pricing | Set-up Pricing |
|-----------------------|-----------------------------------|----------------|
| \$1,200               | \$1,020                           | \$750          |

### Digital Ordering Hardware

| Thermal Receipt Printer - Standard | Thermal Receipt Printer - Adhesive |
|------------------------------------|------------------------------------|
| \$396                              | \$453                              |



Philips Signage Solutions  
D-Line Display

43"

Powered by Android  
450cd/m<sup>2</sup>

**Signage**Solutions

43BDL4050D

## Chasing innovation

powered by Android

Amaze your guests with a smarter, faster, signage display. With integrated WiFi and designed for running Android apps, it's the next evolution in signage solutions.

### Care about you, your business and your audience

- SmartPower for energy saving
- Keep your content up and running with FailOver
- Ensure your content is running with automatic screenshots

### Maximizing the impact of your message

- Connect and control your content via the cloud

### Innovative solutions for any signage application

- Free and easy-to-use content management with SmartCMS
- Save and play content with internal memory
- Android: Run your own app or choose your favorite app to run
- Integrated WiFi
- Enhance your connectivity with an integrated mPCIe slot.

**PHILIPS**



# Highlights

## FailOver



Keeping your content up and running is critical for demanding commercial applications. While it is unlikely you will face a content disaster, FailOver provides content protection with a revolutionary technology that plays back-up content on screen in the event of a media player failure. FailOver automatically kicks in when the primary input fails. Simply select a primary input connection and a FailOver connection and your ready for instant protection.

## SmartPower



The backlight intensity can be controlled and pre-set by the system to reduce the power

consumption by up to 50%, which saves substantially on energy costs.

## PCI Slot

With an integrated PCI slot, you can connect a WiFi/bluetooth or 4G LTE module, allowing for even greater communication with the display. Machine to machine communication is also enhanced, with numerous configurations available for customers to use, such as the ability to expand product features or signal-handling capability.

## Powered by Android

With Android OS integrated into the display, you can work with the most developed OS on the planet and save your own app directly into the display. Or, choose from the large library of Android apps and play content from there. With the built-in scheduler, you can daypart your apps and content based on your customer and time of day and with the auto orientation feature, showing content in portrait or landscape is as simple as turning the display.

## SmartBrowser



Connect and control your content via the cloud with the integrated HTML5 browser. Using the Chromium based browser, design your content online and connect a single display, or your complete network. Show content in both landscape and portrait mode, with fullHD resolution. Streaming content can also be shown in a PIP (picture-in-picture) window. Simply connect the display to the internet using WiFi or with an RJ45 cable, and enjoy your own created playlists

## Proof of Play

Content is king, and with the automatic screenshot feature, you can make sure that your content is up and running at all times. Screenshots are taken throughout the day, which are then stored in the FTP server. From there, the screenshots can be viewed no matter when, or where you are.

# Specifications

## Picture/Display

- Diagonal screen size: 42.5 inch / 107.95 cm
- Panel resolution: 1920x1080p
- Optimum resolution: 1920 x 1080 @ 60Hz
- Brightness: 450 cd/m<sup>2</sup>
- Contrast ratio (typical): 1100:1
- Dynamic contrast ratio: 500,000:1
- Aspect ratio: 16:9
- Response time (typical): 12 ms
- Pixel pitch: 0.49 x 0.49 mm
- Display colors: 16.77 million
- Viewing angle (H / V): 178 / 178 degree

## Connectivity

- Video input: DisplayPort (1.2), HDMI (x2), DVI-D, USB 2.0 (Type A) (x2), USB 2.0 (Type B)
- Video output: DisplayPort, DVI-I
- Audio input: 3.5 mm jack
- Audio output: 3.5mm jack
- Other connections: micro SD, micro USB
- External control: RJ45, RS232C (in/out) 2.5 mm jack, IR (in/out) 3.5 mm jack

## Supported Display Resolution

### Computer formats

| Resolution  | Refresh rate     |
|-------------|------------------|
| 1920 x 1080 | 60Hz             |
| 1440 x 900  | 60Hz             |
| 1366 x 768  | 60Hz             |
| 1360 x 768  | 60Hz             |
| 1280 x 800  | 60Hz             |
| 1280 x 768  | 60Hz             |
| 1024 x 768  | 60Hz             |
| 800 x 600   | 56, 60, 72, 75Hz |
| 640 x 480   | 60, 67, 72, 75Hz |

### Video formats

| Resolution | Refresh rate |
|------------|--------------|
| 1080p      | 50, 60Hz     |
| 1080i      | 50, 60Hz     |
| 720p       | 50, 60Hz     |
| 576i       | 50Hz         |
| 576p       | 50Hz         |
| 480p       | 60Hz         |
| 480i       | 60Hz         |

## Dimensions

- Set dimensions in inch (W x H x D): 39.47 x 23.26 x 2.52 inch
- Set dimensions (W x H x D): 1002.6 x 590.8 x 64.0 mm
- Bezel width: 9.6 mm (T/L/R), 15.7 mm (B)
- Product weight (lb): 23.59 lb
- Product weight: 10.7 kg
- VESA Mount: 400 x 400 mm, M6

## Convenience

- Memory: 16GB eMMC
- Placement: Landscape, Portrait
- Tiled Matrix: Up to 15x 15
- Keyboard control: Hidden, Lockable
- Signal Loop Through: DVI, VGA, RS232, IR Loophrough, DisplayPort
- Network controllable: RJ45, RS232, One Wire (HDMI-CEC), HDMI (One Wire)
- Energy saving functions: Smart Power
- Screen saving functions: Pixel Shift, Low Bright
- Other convenience: Carrying handles, G sensor

## Power

- Consumption (On mode): 59 W
- Standby power consumption: <0.5 W
- Mains power: 100 ~ 240 VAC, 50 ~ 60 Hz

## Operating conditions

- Temperature range (operation): 0 ~ 40 °C
- Temperature range (storage): -20 ~ 60 °C
- Relative humidity: 20 ~ 80 %
- Altitude: 0 ~ 3000 m
- MTBF: 60,000 hour(s)

## Sound

- Built-in speakers: 2 x 10W RMS

## Accessories

- Included accessories: Remote Control, Batteries for remote control, Quick start guide, RS232 cable, VGA cable, AC Power Cord, Edge alignment plates
- Stand: BM05922(Optional)
- Included Accessories: DVI-VGA adapter, Philips logo, RS232 daisy-chain cable

## Multimedia Applications

- USB Playback Audio: AAC, MP3, WMA, M4A, MP1, MP2
- USB Playback Picture: BMP, GIF, JPEG, JPG, PDF, PNG
- USB Playback Video: 3GP, AVI, FLV, MKV, MOV, MP4, TS

## Miscellaneous

- On-Screen Display Languages: English, French, German, Spanish, Polish, Turkish, Russian, Italian, Simplified Chinese, Traditional Chinese, Arabic, Japanese
- Regulatory approvals: CE, FCC, Class B, UL/cUL, CCC, C-Tick, RoHS, GOST, BSMI, CB, J-Moss, PSE, VCCI
- Warranty: 3 year warranty

## Internal Player

- CPU: Quad Core Cortex A9 1.8GHz
- GPU: ARM Mali400 Quad Core 533MHz
- Memory: 2GB DDR3
- Storage: 16GB EMMC

Philips 43BDL4050D  
Version: 1.3  
Release Date: 2016/05/16

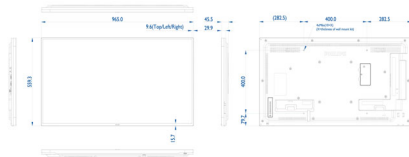

Issue date 2018-04-05

Version: 4.0.1

12 NC: 8670 001 37417  
EAN: 87 12581 73953 9

© 2018 Koninklijke Philips N.V.  
All Rights reserved.

Specifications are subject to change without notice.  
Trademarks are the property of Koninklijke Philips N.V.  
or their respective owners.

[www.philips.com](http://www.philips.com)



Philips Signage Solutions  
D-Line Display

49"

Powered by Android  
450cd/m<sup>2</sup>

**Signage**Solutions

49BDL4050D

## Chasing innovation

powered by Android

Amaze your guests with a smarter, faster, signage display. With integrated WiFi and designed for running Android apps, it's the next evolution in signage solutions.

### **Innovative solutions for any signage application**

- Android: Run your own app or choose your favorite app to run
- Enhance your connectivity with an integrated mPCIe slot.
- Integrated WiFi
- Save and play content with internal memory

### **Maximizing the impact of your message**

- CMND: Take control of your displays
- Create and update content with CMND & Create
- Manage settings of multiple displays with CMND & Control
- Connect and control your content via the cloud

### **Care about you, your business and your audience**

- Ensure your content is running with automatic screenshots
- Keep your content up and running with FailOver
- SmartPower for energy saving

# PHILIPS

# Highlights

## Powered by Android

With Android OS integrated into the display, you can work with the most developed OS on the planet and save your own app directly into the display. Or, choose from the large library of Android apps and play content from there. With the built-in scheduler, you can daypart your apps and content based on your customer and time of day and with the auto orientation feature, showing content in portrait or landscape is as simple as turning the display.

## PCI Slot

With an integrated PCI slot, you can connect a WiFi/bluetooth or 4G LTE module, allowing for even greater communication with the display. Machine to machine communication is also enhanced, with numerous configurations available for customers to use, such as the ability to expand product features or signal-handling capability.

## Internal Memory



Save and play content with internal memory. Upload your media into the display and playback content immediately. Working in conjunction with the internal browser, it also serves as a memory cache when streaming online content. If the network ever fails, the internal memory keeps content running by playing a cached version of the content, ensuring that your media stays up even if the network goes down.

## Proof of Play

Content is king, and with the automatic screenshot feature, you can make sure that your content is up and running at all times. Screenshots are taken throughout the day, which are then stored in the FTP server. From there, the screenshots can be viewed no matter when, or where you are.

## FailOver



Keeping your content up and running is critical for demanding commercial applications. While it is unlikely you will face a content disaster, FailOver provides content protection with a revolutionary technology that plays back-up content on screen in the event of a media player failure. FailOver automatically kicks in when the primary input fails. Simply select a primary input connection and a FailOver connection and your ready for instant protection.

## SmartPower



The backlight intensity can be controlled and pre-set by the system to reduce the power consumption by up to 50%, which saves substantially on energy costs.

## CMND



A robust display management platform, CMND puts the power back into your hands. Update and manage content with CMND & Create or control your settings with CMND & Control. It's all possible with CMND.

## CMND & Control



With CMND & Control, easily manage multiple displays in a central location. With real time display monitoring, setting and software updates from a remote location, and the ability to customize and configure multiple displays at once, such as video wall or menu board displays, controlling your suite of displays has never been easier.

## CMND & Create



Design and create compelling content with CMND & Create, a powerful authoring tool. With a drag and drop interface, preloaded templates, and integrated widgets, you'll be able to amaze your customers with compelling content. Available in portrait and landscape mode.

## SmartBrowser



Connect and control your content via the cloud with the integrated HTML5 browser. Using the Chromium based browser, design your content online and connect a single display, or your complete network. Show content in both landscape and portrait mode, with fullHD resolution. Streaming content can also be shown in a PIP (picture-in-picture) window. Simply connect the display to the internet using WiFi or with an RJ45 cable, and enjoy your own created playlists

# Specifications

## Picture/Display

- Diagonal screen size: 48.5 inch / 123.2 cm
- Panel resolution: 1920x1080p
- Optimum resolution: 1920 x 1080 @ 60Hz
- Brightness: 450 cd/m<sup>2</sup>
- Contrast ratio (typical): 1100:1
- Dynamic contrast ratio: 500,000:1
- Aspect ratio: 16:9
- Response time (typical): 12 ms
- Pixel pitch: 0.55926 x 0.55926 mm
- Display colors: 16.7 million
- Viewing angle (H / V): 178 / 178 degree
- Picture enhancement: 3/2 - 2/2 motion pull down, 3D Combfilter, Motion compens. deinterlacing, 3D MA deinterlacing, Dynamic contrast enhancement, Progressive scan

## Connectivity

- Video input: DisplayPort (1.2), HDMI (x2), DVI-D, USB, VGA (via DVI)
- Video output: DisplayPort, DVI-I, VGA (via DVI-D)
- Audio input: 3.5 mm jack, Audio Left/Right (RCA)
- Audio output: Audio Left/Right (RCA), Ext. speaker cntrl (aud. out)
- Other connections: mPCIe, micro SD, micro USB, USB power outlet (5 V, 2 amp)
- External control: RJ45, RS232C (in/out) 2.5 mm jack, IR (in/out) 3.5 mm jack

## Supported Display Resolution

### Computer formats

| Resolution  | Refresh rate     |
|-------------|------------------|
| 1920 x 1080 | 60Hz             |
| 1440 x 900  | 60Hz             |
| 1366 x 768  | 60Hz             |
| 1360 x 768  | 60Hz             |
| 1280 x 800  | 60Hz             |
| 1280 x 768  | 60Hz             |
| 1024 x 768  | 60Hz             |
| 800 x 600   | 56, 60, 72, 75Hz |
| 640 x 480   | 60, 67, 72, 75Hz |

### Video formats

| Resolution | Refresh rate |
|------------|--------------|
| 1080p      | 50, 60Hz     |
| 1080i      | 50, 60Hz     |

|      |          |
|------|----------|
| 720p | 50, 60Hz |
| 576i | 50Hz     |
| 576p | 50Hz     |
| 480p | 60Hz     |
| 480i | 60Hz     |

## Dimensions

- Set dimensions (W x H x D): 1097.28 x 632.46 x 45.72 mm
- Set dimensions in inch (W x H x D): 43.2 x 24.9 x 1.8 inch
- Bezel width: 9.5 mm (T/L/R), 15.6 mm (B)
- Product weight (lb): 32.41 lb
- Product weight: 14.7 kg
- VESA Mount: 400 x 400 mm, M6

## Convenience

- Placement: Landscape (24/7), Portrait (24/7)
- Tiled Matrix: Up to 15 x 15
- Keyboard control: Hidden, Lockable
- Signal Loop Through: DVI, VGA, RS232, IR Loopthrough, DisplayPort
- Network controllable: RJ45, RS232, One Wire (HDMI-CEC), HDMI (One Wire)
- Energy saving functions: Smart Power
- Screen saving functions: Pixel Shift, Low Bright

## Power

- Standby power consumption: <0.4 W
- Mains power: 100 ~ 240 VAC, 50 ~ 60 Hz
- Consumption (EPA 6.0): 55 W
- Consumption (Typical): 67 W

## Operating conditions

- Temperature range (operation): 0 ~ 40 °C
- Temperature range (storage): -20 ~ 60 °C
- Relative humidity: 20 ~ 80 %
- Altitude: 0 ~ 3000 m
- MTBF: 50,000 hour(s)

## Sound

- Built-in speakers: 2 x 10W RMS

## Accessories

- Included accessories: Remote Control, Batteries for

remote control, Quick start guide, RS232 cable, AC Power Cord

- Stand: BM05922(Optional)
- Optional accessories: ColourCalibrationKit (CCK4601)

## Multimedia Applications

- USB Playback Audio: AAC, AIF, AIFF, M4A, MP3, WAV, WMA, ASF, LPCM, M3U, MP4
- USB Playback Picture: BMP, GIF, JPEG, JPG, PDF
- USB Playback Video: M2TS, M4V, MK3D, MKV, MP4, MPEG, MPG, MTS, TS, TTS, VOB, WMV

## Miscellaneous

- On-Screen Display Languages: English, French, German, Spanish, Polish, Turkish, Russian, Italian, Simplified Chinese, Traditional Chinese, Arabic, Japanese, Danish, Dutch, Finnish, Norwegian, Portuguese, Swedish
- Regulatory approvals: EnergyStar 7.0, CE, FCC, Class B, UL/cUL, CCC, C-Tick, RoHS, GOST, BSMI, CB, J-Moss, PSE, VCCI
- Warranty: 3 year warranty

## Internal Player

- CPU: Quad Core Cortex A9 1.8GHz
- GPU: ARM Mali400 Quad Core 533MHz
- Memory: 2GB DDR3
- Storage: 16GB EMMC

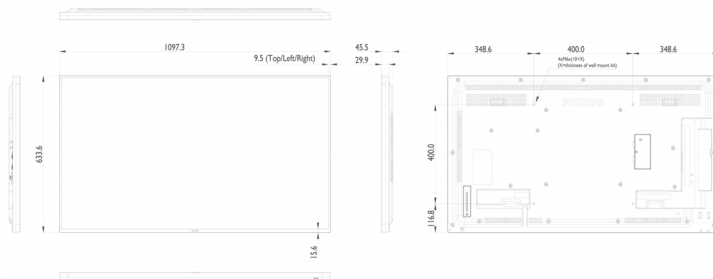

Issue date 2016-12-09

Version: 3.0.1

12 NC: 8670 001 37394  
EAN: 87 12581 74129 7

© 2016 Koninklijke Philips N.V.  
All Rights reserved.

Specifications are subject to change without notice.  
Trademarks are the property of Koninklijke Philips N.V.  
or their respective owners.

[www.philips.com](http://www.philips.com)



Philips Signage Solutions  
D-Line Display

55"

Powered by Android  
450cd/m<sup>2</sup>

**Signage**Solutions

55BDL4050D

## Chasing innovation

powered by Android

Amaze your guests with a smarter, faster, signage display. With integrated WiFi and designed for running Android apps, it's the next evolution in signage solutions.

### **Innovative solutions for any signage application**

- Android: Run your own app or choose your favorite app to run
- Enhance your connectivity with an integrated mPCIe slot.
- Integrated WiFi
- Save and play content with internal memory

### **Maximizing the impact of your message**

- CMND: Take control of your displays
- Create and update content with CMND & Create
- Manage settings of multiple displays with CMND & Control
- Connect and control your content via the cloud

### **Care about you, your business and your audience**

- Ensure your content is running with automatic screenshots
- Keep your content up and running with FailOver
- SmartPower for energy saving

# PHILIPS

# Highlights

## Powered by Android

With Android OS integrated into the display, you can work with the most developed OS on the planet and save your own app directly into the display. Or, choose from the large library of Android apps and play content from there. With the built-in scheduler, you can daypart your apps and content based on your customer and time of day and with the auto orientation feature, showing content in portrait or landscape is as simple as turning the display.

## PCI Slot

With an integrated PCI slot, you can connect a WiFi/bluetooth or 4G LTE module, allowing for even greater communication with the display. Machine to machine communication is also enhanced, with numerous configurations available for customers to use, such as the ability to expand product features or signal-handling capability.

## Internal Memory



Save and play content with internal memory. Upload your media into the display and playback content immediately. Working in conjunction with the internal browser, it also serves as a memory cache when streaming online content. If the network ever fails, the internal memory keeps content running by playing a cached version of the content, ensuring that your media stays up even if the network goes down.

## Proof of Play

Content is king, and with the automatic screenshot feature, you can make sure that your content is up and running at all times. Screenshots are taken throughout the day, which are then stored in the FTP server. From there, the screenshots can be viewed no matter when, or where you are.

## FailOver



Keeping your content up and running is critical for demanding commercial applications. While it is unlikely you will face a content disaster, FailOver provides content protection with a revolutionary technology that plays back-up content on screen in the event of a media player failure. FailOver automatically kicks in when the primary input fails. Simply select a primary input connection and a FailOver connection and your ready for instant protection.

## SmartPower



The backlight intensity can be controlled and pre-set by the system to reduce the power consumption by up to 50%, which saves substantially on energy costs.

## CMND

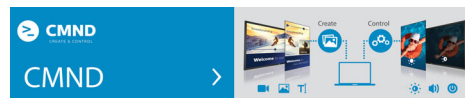

A robust display management platform, CMND puts the power back into your hands. Update and manage content with CMND & Create or control your settings with CMND & Control. It's all possible with CMND.

## CMND & Control



With CMND & Control, easily manage multiple displays in a central location. With real time display monitoring, setting and software updates from a remote location, and the ability to customize and configure multiple displays at once, such as video wall or menu board displays, controlling your suite of displays has never been easier.

## CMND & Create



Design and create compelling content with CMND & Create, a powerful authoring tool. With a drag and drop interface, preloaded templates, and integrated widgets, you'll be able to amaze your customers with compelling content. Available in portrait and landscape mode.

## SmartBrowser



Connect and control your content via the cloud with the integrated HTML5 browser. Using the Chromium based browser, design your content online and connect a single display, or your complete network. Show content in both landscape and portrait mode, with fullHD resolution. Streaming content can also be shown in a PIP (picture-in-picture) window. Simply connect the display to the internet using WiFi or with an RJ45 cable, and enjoy your own created playlists

# Specifications

## Picture/Display

- Diagonal screen size: 54.64 inch / 138.8 cm
- Panel resolution: 1920x1080p
- Optimum resolution: 1920 x 1080 @ 60Hz
- Brightness: 450 cd/m<sup>2</sup>
- Contrast ratio (typical): 1100:1
- Dynamic contrast ratio: 500,000:1
- Aspect ratio: 16:9
- Response time (typical): 12 ms
- Pixel pitch: 0.63 x 0.63 mm
- Display colors: 16.7 million
- Viewing angle (H / V): 178 / 178 degree
- Picture enhancement: 3/2 - 2/2 motion pull down, 3D Combfilter, Motion compens. deinterlacing, 3D MA deinterlacing, Dynamic contrast enhancement, Progressive scan

## Connectivity

- Video input: DisplayPort (1.2), HDMI (x2), DVI-D, USB, VGA (via DVI)
- Video output: DisplayPort, DVI-I, VGA (via DVI-D)
- Audio input: 3.5 mm jack, Audio Left/Right (RCA)
- Audio output: Audio Left/Right (RCA), Ext. speaker cntrl (aud. out)
- Other connections: mPCIe, micro SD, micro USB, USB power outlet (5 V, 2 amp)
- External control: RJ45, RS232C (in/out) 2.5 mm jack, IR (in/out) 3.5 mm jack

## Supported Display Resolution

### Computer formats

| Resolution  | Refresh rate     |
|-------------|------------------|
| 1920 x 1080 | 60Hz             |
| 1440 x 900  | 60Hz             |
| 1366 x 768  | 60Hz             |
| 1360 x 768  | 60Hz             |
| 1280 x 800  | 60Hz             |
| 1280 x 768  | 60Hz             |
| 1024 x 768  | 60Hz             |
| 800 x 600   | 56, 60, 72, 75Hz |
| 640 x 480   | 60, 67, 72, 75Hz |

### Video formats

| Resolution | Refresh rate |
|------------|--------------|
| 1080p      | 50, 60Hz     |
| 1080i      | 50, 60Hz     |

|      |          |
|------|----------|
| 720p | 50, 60Hz |
| 576i | 50Hz     |
| 576p | 50Hz     |
| 480p | 60Hz     |
| 480i | 60Hz     |

## Dimensions

- Set dimensions (W x H x D): 1231.9 x 711.2 x 45.72 mm
- Set dimensions in inch (W x H x D): 48.5 x 28.0 x 1.8 inch
- Bezel width: 9.5 mm (T/L/R) 15.6mm (B)
- Product weight (lb): 39.68 lb
- Product weight: 18.0 kg
- VESA Mount: 400 x 400 mm, M6

## Convenience

- Placement: Landscape (24/7), Portrait (24/7)
- Tiled Matrix: Up to 15 x 15
- Keyboard control: Hidden, Lockable
- Signal Loop Through: DVI, VGA, RS232, IR Loopthrough, DisplayPort
- Network controllable: RJ45, RS232, One Wire (HDMI-CEC), HDMI (One Wire)
- Energy saving functions: Smart Power
- Screen saving functions: Pixel Shift, Low Bright

## Power

- Standby power consumption: <0.4 W
- Mains power: 100 ~ 240 VAC, 50 ~ 60 Hz
- Consumption (EPA 6.0): 64 W
- Consumption (Typical): 76 W

## Operating conditions

- Temperature range (operation): 0 ~ 40 °C
- Temperature range (storage): -20 ~ 60 °C
- Relative humidity: 20 ~ 80 %
- Altitude: 0 ~ 3000 m
- MTBF: 50,000 hour(s)

## Sound

- Built-in speakers: 2 x 10W RMS

## Accessories

- Included accessories: Remote Control, Batteries for

- remote control, Quick start guide, RS232 cable, AC Power Cord
- Stand: BM05922 (Optional)
- Optional accessories: ColourCalibrationKit (CCK4601)

## Multimedia Applications

- USB Playback Audio: AAC, AIF, AIFF, M4A, MP3, WAV, WMA, ASF, LPCM, M3U, MP4
- USB Playback Picture: BMP, GIF, JPEG, JPG, PDF
- USB Playback Video: M2TS, M4V, MK3D, MKV, MP4, MPEG, MPG, MTS, TS, TTS, VOB, WMV

## Miscellaneous

- On-Screen Display Languages: English, French, German, Spanish, Polish, Turkish, Russian, Italian, Simplified Chinese, Traditional Chinese, Arabic, Japanese, Danish, Dutch, Finnish, Norwegian, Portuguese, Swedish
- Regulatory approvals: EnergyStar 7.0, CE, FCC, Class B, UL/cUL, CCC, C-Tick, RoHS, GOST, BSMI, CB, J-Moss, PSE, VCCI
- Warranty: 3 year warranty

## Internal Player

- CPU: Quad Core Cortex A9 1.8GHz
- GPU: ARM Mali400 Quad Core 533MHz
- Memory: 2GB DDR3
- Storage: 16GB EMMC

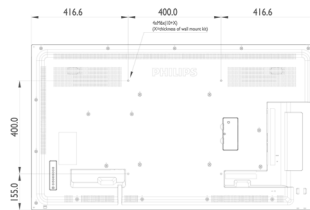

Issue date 2016-12-09

Version: 4.0.1

12 NC: 8670 001 37395  
EAN: 87 12581 74128 0

© 2016 Koninklijke Philips N.V.  
All Rights reserved.

Specifications are subject to change without notice.  
Trademarks are the property of Koninklijke Philips N.V.  
or their respective owners.

[www.philips.com](http://www.philips.com)





Philips Signage Solutions  
D-Line Display

65"

Powered by Android  
450cd/m<sup>2</sup>

**Signage**Solutions

65BDL4050D

## Chasing innovation

powered by Android

Amaze your guests with a smarter, faster, signage display. With integrated WiFi and designed for running Android apps, it's the next evolution in signage solutions.

### **Innovative solutions for any signage application**

- Android: Run your own app or choose your favorite app to run
- Enhance your connectivity with an integrated mPCIe slot.
- Integrated WiFi
- Save and play content with internal memory

### **Maximizing the impact of your message**

- CMND: Take control of your displays
- Create and update content with CMND & Create
- Manage settings of multiple displays with CMND & Control
- Connect and control your content via the cloud

### **Care about you, your business and your audience**

- Ensure your content is running with automatic screenshots
- Keep your content up and running with FailOver
- Simplify meetings with FailOver for conferencing
- SmartPower for energy saving

# PHILIPS

D-Line Display  
65" Powered by Android, 450cd/m<sup>2</sup>

# Highlights

## Powered by Android

With Android OS integrated into the display, you can work with the most developed OS on the planet and save your own app directly into the display. Or, choose from the large library of Android apps and play content from there. With the built-in scheduler, you can daypart your apps and content based on your customer and time of day and with the auto orientation feature, showing content in portrait or landscape is as simple as turning the display.

## PCI Slot

With an integrated PCI slot, you can connect a WiFi/bluetooth or 4G LTE module, allowing for even greater communication with the display. Machine to machine communication is also enhanced, with numerous configurations available for customers to use, such as the ability to expand product features or signal-handling capability.

## Internal Memory



Save and play content with internal memory. Upload your media into the display and playback content immediately. Working in conjunction with the internal browser, it also serves as a memory cache when streaming online content. If the network ever fails, the internal memory keeps content running by playing a cached version of the content, ensuring that your media stays up even if the network goes down.

## Proof of Play

Content is king, and with the automatic screenshot feature, you can make sure that your content is up and running at all times. Screenshots are taken throughout the day, which are then stored in the FTP server. From there, the screenshots can be viewed no matter when, or where you are.

## FailOver



Keeping your content up and running is critical for demanding commercial applications. While it is unlikely you will face a content disaster, FailOver provides content protection with a revolutionary technology that plays back-up content on screen in the event of a media player failure. FailOver automatically kicks in when the primary input fails. Simply select a primary input connection and a FailOver connection and your ready for instant protection.

## FailOver for Meeting Rooms

Using FailOver, simplify your presentations and videoconferencing. When a meeting or conference room is not in use, background content can run from whatever input source you choose. When the meeting starts and you need to share a presentation or your screen, simply connect your computer and the display automatically switches inputs and shows what's on your screen, with no need to manually switch inputs.

## SmartPower



The backlight intensity can be controlled and pre-set by the system to reduce the power consumption by up to 50%, which saves substantially on energy costs.

65BDL4050D/00

## CMND

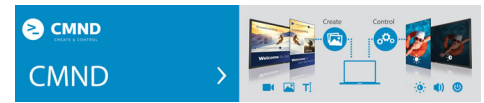

A robust display management platform, CMND puts the power back into your hands. Update and manage content with CMND & Create or control your settings with CMND & Control. It's all possible with CMND.

## CMND & Control

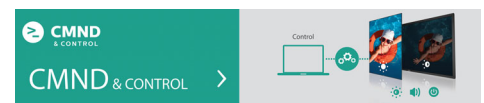

With CMND & Control, easily manage multiple displays in a central location. With real time display monitoring, setting and software updates from a remote location, and the ability to customize and configure multiple displays at once, such as video wall or menu board displays, controlling your suite of displays has never been easier.

## CMND & Create

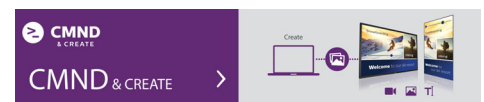

Design and create compelling content with CMND & Create, a powerful authoring tool. With a drag and drop interface, preloaded templates, and integrated widgets, you'll be able to amaze your customers with compelling content. Available in portrait and landscape mode.

# Specifications

## Picture/Display

- Diagonal screen size: 65.5 inch / 166.37 cm
- Panel resolution: 1920x1080p
- Optimum resolution: 1920 x 1080 @ 60Hz
- Brightness: 450 cd/m<sup>2</sup>
- Contrast ratio (typical): 1100:1
- Dynamic contrast ratio: 500,000:1
- Aspect ratio: 16:9
- Response time (typical): 12 ms
- Pixel pitch: 0.744 x 0.744 mm
- Display colors: 16.7 million
- Viewing angle (H / V): 178 / 178 degree
- Picture enhancement: 3/2 - 2/2 motion pull down, 3D Combfilter, Motion compens. deinterlacing, 3D MA deinterlacing, Dynamic contrast enhancement, Progressive scan

## Connectivity

- Video input: DisplayPort (1.2), HDMI (x2), DVI-D, USB, VGA (via DVI)
- Video output: DisplayPort, DVI-I, VGA (via DVI-D)
- Audio input: 3.5 mm jack, Audio Left/Right (RCA)
- Audio output: Audio Left/Right (RCA), Ext. speaker cntrl (aud. out)
- Other connections: mPCIe, micro SD, micro USB, USB power outlet (5 V, 2 amp)
- External control: RJ45, RS232C (in/out) 2.5 mm jack, IR (in/out) 3.5 mm jack

## Supported Display Resolution

### • Computer formats

| Resolution  | Refresh rate     |
|-------------|------------------|
| 1920 x 1080 | 60Hz             |
| 1440 x 900  | 60Hz             |
| 1366 x 768  | 60Hz             |
| 1360 x 768  | 60Hz             |
| 1280 x 800  | 60Hz             |
| 1280 x 768  | 60Hz             |
| 1024 x 768  | 60Hz             |
| 800 x 600   | 56, 60, 72, 75Hz |
| 640 x 480   | 60, 67, 72, 75Hz |

### • Video formats

| Resolution | Refresh rate |
|------------|--------------|
| 1080p      | 50, 60Hz     |
| 1080i      | 50, 60Hz     |

|      |          |
|------|----------|
| 720p | 50, 60Hz |
| 576i | 50Hz     |
| 576p | 50Hz     |
| 480p | 60Hz     |
| 480i | 60Hz     |

## Dimensions

- Set dimensions (W x H x D): 1452.0 x 833.1 x 63.5 mm
- Set dimensions in inch (W x H x D): 57.17 x 32.80 x 2.50 inch
- Bezel width: 9.5 (T/L/R) 15.6 (B)
- Product weight (lb): 65.7 lb
- Product weight: 29.8 kg
- VESA Mount: 400 x 400, M6
- Smart Insert mount: 100 x 100 mm, 100 x 200 mm

## Convenience

- Placement: Landscape (24/7), Portrait (24/7)
- Tiled Matrix: Up to 15 x 15
- Keyboard control: Hidden, Lockable
- Signal Loop Through: DVI, VGA, RS232, IR Loopthrough, DisplayPort
- Network controllable: RJ45, RS232, One Wire (HDMI-CEC), HDMI (One Wire)
- Energy saving functions: Smart Power
- Screen saving functions: Pixel Shift, Low Bright
- Ease of installation: Smart Insert
- Picture in picture: PIP

## Power

- Standby power consumption: <0.4 W
- Mains power: 100 ~ 240 VAC, 50 ~ 60 Hz
- Consumption (EPA 6.0): 99 W
- Consumption (Typical): 103 W

## Operating conditions

- Temperature range (operation): 0 ~ 40 °C
- Temperature range (storage): -20 ~ 60 °C
- Relative humidity: 20 ~ 80 %
- Altitude: 0 ~ 3000 m
- MTBF: 50,000 hour(s)

## Sound

- Built-in speakers: 2 x 10W RMS

## Accessories

- Included accessories: Remote Control, Batteries for remote control, Quick start guide, RS232 cable, AC Power Cord
- Stand: BMO5922 (Optional)
- Optional accessories: ColourCalibrationKit (CCK4601)

## Multimedia Applications

- USB Playback Audio: AAC, AIF, AIFF, M4A, MP3, WAV, WMA, ASF, LPCM, M3U, MP4
- USB Playback Picture: BMP, GIF, JPEG, JPG, PDF
- USB Playback Video: M2TS, M4V, MK3D, MKV, MP4, MPEG, MPG, MTS, TS, TTS, VOB, WMV

## Miscellaneous

- On-Screen Display Languages: English, French, German, Spanish, Polish, Turkish, Russian, Italian, Simplified Chinese, Traditional Chinese, Arabic, Japanese, Danish, Dutch, Finnish, Norwegian, Portuguese, Swedish
- Regulatory approvals: EnergyStar 7.0, CE, FCC, Class B, UL/cUL, CCC, C-Tick, RoHS, GOST, BSMI, CB, J-Moss, PSE, VCCI
- Warranty: 3 year warranty

## Internal Player

- CPU: Quad Core Cortex A9 1.8GHz
- GPU: ARM Mali400 Quad Core 533MHz
- Memory: 2GB DDR3
- Storage: 16GB EMMC

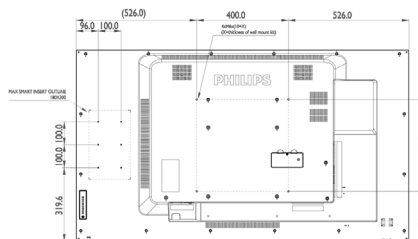
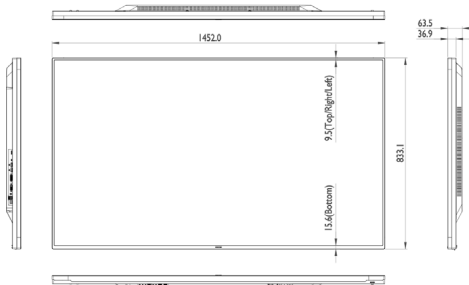

Issue date 2016-12-09

Version: 2.0.1

12 NC: 8670 001 37396  
EAN: 87 12581 73999 7

© 2016 Koninklijke Philips N.V.  
All Rights reserved.

Specifications are subject to change without notice.  
Trademarks are the property of Koninklijke Philips N.V.  
or their respective owners.

[www.philips.com](http://www.philips.com)



## Nutrislice Software Subscription Agreement

Version 3.0.1 – For Schools and School Districts  
Last updated July 7, 2017

This Software Subscription Agreement (“Agreement”) governs your acquisition and use of software services from Nutrislice, Inc., a Delaware corporation (“Nutrislice”) headquartered in Broomfield, Colorado.

By executing an Order Contract that references this Agreement, you agree to the terms and conditions herein. If you are entering into this Agreement on behalf of a company, government organization, or other legal entity, you represent that you have the authority to bind such entity to this Agreement and are doing so by executing the Order Contract herewith, in which case the terms “You” or “Your” shall refer to such entity. If you do not have such authority to bind the entity you represent, or if you do not agree with these terms and conditions, you must not accept the Order Contract referencing this Agreement and may not use the Software Services.

**1. DEFINITIONS.** In addition to other terms defined in Title Case throughout this Agreement, usage in Title Case of the terms defined in this section shall have the following meanings:

**1.1 “Authorized User(s)”** means individuals who are authorized by You to use the Software Services. Authorized Users may include but are not limited to You, Your employees, consultants, contractors, agents, Your students (including minors) and/or other third parties with whom You transact business, who You have authorized to access and/or use Nutrislice Software.

**1.2 “End User(s)”** means individuals who consume or interact with information or interfaces made available via the Software Services, including Authorized User(s), third parties with whom You transact business, and persons from the general public who engage with Your application of any Nutrislice Software.

**1.3 “Order Contract”** means a contract in which this Agreement is attached or referenced, which conveys the terms and conditions of an agreement between the Parties for the purchase of one or more Subscriptions and/or other associated services and/or products from Nutrislice. The parties agree that an Order Contract may be formed either by execution of an Order Contract document, or by acceptance of an offer, quote or proposal from Nutrislice that incorporates or references this Agreement.

**1.4 “Parties”** shall mean both You and Nutrislice; **“Party”** shall mean either You or Nutrislice, according to the context of its usage.

**1.5 “Personal Data”** means any information that is considered to “personally-identifiable,” “personal data,” or information that may be used to identify an individual, as defined in each context herein by the Privacy Law(s) applicable to such information, including without limitation name, birth date, address, username/password, etc.

**1.6 “Privacy Laws”** means all data protection and privacy laws to the extent applicable to the collection, use, storage, or disclosure, or processing of the Personal Data hereunder, including but not be limited to:

- a) all United States Federal Trade Commission (“**FTC**”) rules, regulations and guidance relating to the collection, use, disclosure and processing of Personal Data;
- b) the Children’s Online Privacy Protection Act of 1998 (“**COPPA**”), including any regulations and guidance issued thereunder;
- c) The Family Education Rights and Privacy Act (“**FERPA**”), including any relevant regulations, and guidance issued thereunder, as well as any other federal laws, state laws, rules and regulations relating to the protection of Personal Data of students; and
- d) The Payment Card Industry Data Security Standard v3.2 or any successor standard thereto which has been in effect for at least 1 year (“**PCI**”).

**1.7 “Software Services”** or **“Software”** means any software application (including web-based software) that is created and/or operated by Nutrislice. Software Services specifically refers to Software, provided by Nutrislice as a subscription-based service.

**1.8 “Subscription”** means a grant from Nutrislice of non-exclusive, non-transferable, non-sublicensable, limited rights for You and Your employees and authorized Users to access and/or use the Software specified in Your Order Contract for the time period specified therein.

**1.9 “User Data”** means all electronic data or information submitted by You or Authorized Users of the Software Services and any data derived directly therefrom by any Nutrislice software, which is not Personal Data.



1.10 "Us," "We" or "Our" means Nutrislice and/or any affiliate thereof.

## 2. GENERAL

**2.1 Our Responsibilities and Service Level Commitments.** Subject to the terms of this Agreement and the applicable Order Contract, We shall: (a) provide you with access to Software Services that perform the functions and/or services described in any Order Contract and documentation; (b) provide standard email and phone support for the Software Services to You during standard business hours of 7:30 AM - 4:30 PM, MT, and any additional or upgraded support and consultations as specified in Your Order Contract; (c) use commercially reasonable efforts to make Subscribed-to Software Services available with at least 98% availability, 24 hours a day, 7 days a week, except for: (i) planned downtime, which We shall minimize and limit to low traffic times; (ii) occasional temporary outages caused by unforeseen technological issues of our hosting platform(s) or a third-party technological dependency, which We shall use commercially reasonable efforts to expedite resolution in a rapid manner, given that continual uptime is in Our own interest; or (iii) any unavailability caused by circumstances beyond Our reasonable control, including without limitation, acts of God, acts of government, floods, fires, earthquakes, civil unrest, acts of terror, strikes or other labor problems (other than those involving Our employees), Internet service provider failures or delays, or denial of service attacks; and (d) provide the Software Services only in accordance with applicable laws and government regulations.

### 2.2 Your Responsibilities.

a. You shall (i) be responsible for Authorized Users' compliance with this Agreement; (ii) be responsible for the accuracy, quality and legality of any User Data; (iii) use commercially reasonable efforts to prevent unauthorized access to or use of the Software, and notify Us promptly of any such unauthorized access or use; (iv) use the Software Services only in accordance with applicable laws and government regulations; (v) if the Software Services are provided to minors or minors are the intended audience of the output of the Software, assure that any federal, state, or local (including school) regulations, guidelines, or laws are followed with respect to Your particular use of the Software Services with minors; and (vi) to cooperate with Us and Our licensors (if any) in connection with efforts to protect intellectual property and other legal rights in the Software.

b. You shall not use access to the Software or provide access thereto to any third party for any of the following: (i) to make secured areas (those for which a password, or other credential is required) of the Software available to anyone other than Authorized Users; (ii) to sell, resell, rent or lease the Software Services; (iii) to store or transmit obscene, pornographic, libelous, unlawful or tortious material, or material in violation of third-party privacy or intellectual property rights; (iv) to use the Software to store or transmit any harmful, exploitative or malicious code or program; (v) to interfere with, access without authorization, or disrupt the integrity or performance of the Software, data contained therein, or any third-party dependencies; (vi) to reverse engineer the Software; (vii) to create any competing product or service or product with similar features to the Software or to provide access to the Software or information about the Software or derived from the Software with any Nutrislice competitor; (viii) to create any application, web site or program code incorporating any interfaces, API's or URL's exposed by the Software without written authorization from Us; (ix) to copy, frame or mirror any graphics, code, content or portion of the Software without written authorization from Us; (x) to disseminate performance information or analysis from any source relating to the Software; or (xii) to remove any product identification, copyright notice or other proprietary marking from the Software.

**2.3 Subscriptions.** For the duration of each fully paid Subscription, Nutrislice will provide access to Software specified in your Order Contract and corresponding hosting, system and general updates, client support, and maintenance. Subscriptions are limited to products, modules and services, at purchased Subscription level(s), as specified in Your Order Contract, and include all standard improvements and changes made to those products, modules and services at the purchased Subscription level(s), for the duration of the Subscription(s). If you wish to purchase additional software, services, or Subscription level(s), such purchase shall be made in an addendum or additional Order Contract that references Your original Order Contract, and the Subscription costs and terms for such subsequent additional products will be prorated so that they co-terminate and/or co-renew with this Agreement. You acknowledge that updates and changes to the software will be provided as part of your Subscription, and agree that Nutrislice may change, update or remove features or functions of the software at its discretion, so long as the core software functionality corresponding to your purchased Subscription(s) are not impeded.

**2.4 Customizations and modifications.** To the extent that You request or require customizations or modifications to the Nutrislice Software, Nutrislice only agrees to such customizations or modifications if they are explicitly reflected in your Order Contract. You recognize that any outstanding or future requests for customizations not reflected in an Order Contract will only be considered at Nutrislice's sole discretion and may require an additional charge and an additional Order Contract or Addendum agreed to by both Parties.

**2.5 Menu data intended for publishing.** Nutrislice is primarily a platform to assist You in marketing and publishing information about Your program to Your consumers and potential consumers amongst the general public. As such, You acknowledge that the food and menu information that you provide to Nutrislice will be made



electronically available to consumers and the general public without access restrictions, and that third parties will inherently be able to view, consume, archive, analyze and share such data, and as such, You agree to hold Nutrislice harmless for any consequence of such information being made publicly available. Nutrislice's responsibility with respect to Personal Data and User Data is defined in Section 8.

**2.6 Usage Limitations.** Your Subscription may be subject to limitations, such as, for example, limits on (a) disk storage space; (b) the number of text messages that may be sent and/or received via any SMS system included in the Software Services; (c) limits on push notifications; or (d) the number of locations, rooms, or screens in which the software may be used or displayed. Such limits shall be communicated to you in Writing as part of your Order Contract.

### 3. FEES AND PAYMENT

**3.1 Fees.** You shall pay all fees that are specified in all Order Contracts, on time. Except as otherwise specified herein or in a corresponding Order Contract, (a) fees are based on Software Services Subscriptions purchased and not actual usage, (b) payment obligations are non-cancelable and fees paid are non-refundable, and (c) the number of User Subscriptions, text messages, or screen/location licenses purchased cannot be decreased during the relevant Subscription term for refund or credit.

**3.2 Invoicing and Payment.** All charges for the Software Services shall be made according to the terms of the Order Contract. Unless otherwise stated in the Order Contract, invoiced charges are due 30 days from the invoice date. You are responsible for providing complete and accurate billing and contact information to Us and notifying Us of any changes to such information. For placing orders of Nutrislice products or services, Nutrislice may require you to submit the details of an order using a specific form, document, or website for it to be accepted.

**3.3 Overdue Charges.** If any invoiced amount is not received by Us by the due date, then at Our discretion, (a) such charges may accrue late interest at the rate of 1.5% of the outstanding balance per month, or the maximum rate permitted by law, whichever is lower, from the date such payment was due until the date paid, and/or (b) We may condition future Subscription renewals and Order Contracts on payment terms shorter than those specified in Section 3.2.

**3.4 Suspension of Service.** If any amount owed by You to Us under this or any other agreement for Software Services is thirty (30) or more days overdue, We may, without limiting Our other rights and remedies, suspend Software Services to You until such amounts are paid in full. We will give You at least fifteen (15) days notice that Your account is overdue prior to suspension.

**3.5 Taxes.** Unless otherwise stated, Our fees do not include any taxes, levies, duties or similar governmental assessments of any nature, including but not limited to value-added, sales, use or withholding taxes, assessable by any local, state, provincial, federal or foreign jurisdiction (collectively, "**Taxes**"). You are responsible for paying all such Taxes associated with Your purchases hereunder, not including any tax premised on the Nutrislice's net income. If We have the legal obligation to pay or collect Taxes for which You are responsible under this paragraph, the appropriate amount shall be invoiced to and paid by You, unless You provide Us with a valid tax exemption certificate authorized by the appropriate taxing authority.

### 4. PROPRIETARY RIGHTS

**4.1 Reservation of Rights in Software.** Subject to the limited rights expressly granted hereunder, We reserve all rights, title and interest in and to the Software, including all related intellectual property rights. No rights are granted to You hereunder other than limited usage rights for a limited time, as expressly set forth herein and/or in any Order Contract.

**4.2 Reservation of Rights to Content.** Subject to the limited rights expressly granted hereunder, We reserve all rights, title and interest in and to any content owned or licensed by Nutrislice that is provided with the Software Services, including any images, text, video, and other content or files. No rights to Content are granted to You hereunder other than limited usage rights of the content within the Software for the duration of corresponding active Subscription(s).

**4.3 Suggestions.** To the extent applicable and possible, You hereby grant Us a royalty-free, worldwide, irrevocable, perpetual license to use and incorporate into the Software any suggestions, enhancement requests, recommendations or other feedback provided by You, Authorized Users or End Users.

### 5. CONFIDENTIALITY

**5.1 Confidential Information.** As used herein, "**Confidential Information**" means all confidential information disclosed by a Party ("**Disclosing Party**") to the other Party ("**Receiving Party**"), whether orally or in writing, that is designated as confidential or that reasonably should be understood to be confidential given the nature of the



information and the circumstances of disclosure. Your Confidential Information shall include any data which is provided to Us and is indicated as being private or confidential in a written communication to an authorized Nutrislice employee or agent. Our Confidential Information shall include the Software, including any designs, pages, user interfaces, html, scripts, source code, or internal mechanisms thereof, as well as business and marketing plans, technology and technical information, product plans and designs, and pricing. Confidential Information of each Party shall include the terms and conditions of this Agreement and Order Contracts and attachments thereto and business plans or processes disclosed by such Party, and any other information that is specified to be confidential in an Order Contract.

**5.2 Exclusions from Confidential Information.** Confidential Information shall not include any information that (i) is or becomes generally known to the public without breach of any obligation owed to the Disclosing Party, (ii) is received from a third party without breach of any obligation owed to the Disclosing Party, (iii) was independently developed by the Receiving Party, or (iv) is **subject to immediate public disclosure or public availability under any public information law**. The Receiving Party may disclose Confidential Information of the Disclosing Party if it is compelled by law to do so, provided the Receiving Party gives the Disclosing Party prior notice of such compelled disclosure (to the extent legally permitted) and reasonable assistance if the Disclosing Party wishes to contest the disclosure. User Data and Personal Data shall be provided the confidentiality and protections described under Section 8 herein, but shall not generally be deemed Confidential Information under this Section (5).

**5.3 Protection of Confidential Information.** The Receiving Party shall use the same degree of care that it uses to protect the confidentiality of its own confidential information of like kind (but in no event less than reasonable care) (a) not to use any Confidential Information of the Disclosing Party for any purpose outside the scope of this Agreement, and (b) except as otherwise authorized by the Disclosing Party in writing, to limit access to Confidential Information of the Disclosing Party to those of its and any affiliates' employees, contractors and agents who need such access for purposes consistent with this Agreement. You shall not disclose the terms of this Agreement or any Order Contract to any third party other than legal counsel and accountants without Our prior written consent.

## 6. REPRESENTATIONS, WARRANTY AND DISCLAIMER

**6.1 Representations.** Each Party represents that it has validly entered into this Agreement and has the legal power to do so. We represent that we have all necessary rights, including intellectual property rights, to provide you with the Software Services specified in Your Order Contract.

**6.2 WARRANTY.** WE WARRANT THAT THE SOFTWARE WILL PERFORM THE FUNCTIONS DESCRIBED IN YOUR ORDER CONTRACT.

**6.3 DISCLAIMER.** WE MAKE NO OTHER WARRANTIES, GUARANTEES OR REPRESENTATIONS TO YOU AS TO THE SOFTWARE AND SOFTWARE SERVICES. ALL IMPLIED WARRANTIES AND CONDITIONS, INCLUDING BUT NOT LIMITED TO THE IMPLIED WARRANTIES OF MERCHANTABILITY, FITNESS FOR A PARTICULAR PURPOSE OR NON-INFRINGEMENT, ARE HEREBY DISCLAIMED BY NUTRISLICE AND WAIVED BY YOU, TO THE EXTENT PERMITTED BY APPLICABLE LAW.

## 7. ALLERGENS & DIETARY RESTRICTIONS NOTICE AND DISCLAIMER

**7.1 Notice of Limitations, Acknowledgment, and Disclaimer.** Depending on the Software Services You purchase, the Software may include one or more features ("Dietary Information Functionality") that may be used by End Users to identify and/or filter menu items based on particular criteria ("Dietary Information"), including ingredients, allergens, particular nutritional information (e.g., carbohydrates or other nutrient data), or conformity to mandatory or voluntary dietary restrictions. You agree and acknowledge that We do not identify any Dietary Information and that the accuracy of any such information in the system is the sole responsibility of You. You agree and acknowledge that the effectiveness of the Dietary Information Functionality in identifying the presence of Dietary Information is **limited** by the following: (a) Each manufacturer of menu items sold within the district must accurately and clearly provide food information and identify ALL the ingredients and allergens in the information they provide to You; (b) You must accurately enter the information provided by the manufacturer in ALL published menu items in a timely manner before publishing information to End Users; (c) Dietary Information may not be accurate due to substitutions, alterations, changes in supplier, mislabeling by manufacturer, or by failure of You to update your database; (d) Authorized Users and End Users may fail to identify an allergen, mistakenly identify an allergen, or improperly enter data into the Software; and (e) in the case that We provides human services or automation in importing food data from Your menu planning or inventory systems, that it is Your responsibility to verify that such food data is imported properly and that Dietary Information is accurately reflected in the Nutrislice system. We hereby disclaim any responsibility and You agree to accept responsibility and hold Us harmless for the accuracy of Dietary Information inputted into Nutrislice software, whether by You, by Your agent, or by any automated process or human input service that is provided to You as a convenience by Us. You agree to assess the output of the Dietary Information Functionality, and that if you find the output, formatting, and/or user interface of the Dietary Information Functionality to be inadequate, you will disable the Dietary Information Functionality. **The Dietary Information Functionality should never be a substitute or**



replacement for competent medical advice, or End Users' own proper due diligence. We assume no liability for any adverse reactions to food consumed, or food items one may come in contact with.

## 8. PRIVACY

### 8.1 Data Rights and Licenses

**8.1.1 Ownership.** For avoidance of doubt, as between Nutrislice and Client, Client is the sole and exclusive owner of all Personal Data.

**8.1.2 License.** Subject to the Section 8.1.1, Client grants Nutrislice the right, during the Term of the Agreement, to access, collect, use, copy, assemble, compile, analyze, modify, transform, receive and transmit Personal Data and User Data for the purposes set forth in the Agreement. Further, to the extent allowed under Applicable Law, Nutrislice may use Personal Data and User Data in connection with optimization, statistical analysis, and product improvement, the de-identified results of which shall be owned exclusively by Nutrislice.

**8.2 Return of Data.** At any time during the Term, at Client's written request, or upon the termination or expiration of this Agreement for any reason, Nutrislice shall promptly return to Client all copies, whether in written, electronic, or other form or media, of Personal Data or User Data in its possession or control or securely dispose of all such copies, and shall upon request by Client provide written certification by an officer of Nutrislice to Client that such Personal Data has been returned to Client or disposed of securely. Nutrislice shall comply with all reasonable directions provided by Client with respect to the return or disposal of Personal Data or User Data, including without limitation returning the Personal Data or User Data in the format reasonably requested by Client, subject to a reasonable charge if such formatting causes Nutrislice to incur additional expenses. Notwithstanding the foregoing, Nutrislice may retain copies of any Personal Data or User Data to the extent reasonable or necessary for recordkeeping, legal compliance, accounting or other similar purposes.

### 8.3 Data Privacy Obligations

**8.3.1 Client Obligations.** Client shall: (a) not provide Nutrislice with any PHI as defined in 45 CFR Part 160 (HIPAA), and promptly notify Nutrislice if Client discovers that it has done so; (b) comply, and require compliance by its licensors (where applicable), with all Privacy Laws regarding the collection, use, handling, processing, access, security, and disclosure of Personal Data; and (c) obtain, or require its licensors to obtain, any and all consents from individuals, or in the case of a minors or where required by law, of any parent or legal guardian which are or may be required by the Privacy Laws applicable to the Personal Data.

**8.3.2 Nutrislice Obligations.** Nutrislice shall implement and maintain commercially reasonable administrative, technical, and physical safeguards, including procedures and practices with regard to Personal Data in Nutrislice's possession and control designed to (i) ensure the security, confidentiality, and integrity of the Personal Data, (ii) protect against any anticipated threats or hazards to the security or integrity of the Personal Data, and (iii) protect against unauthorized access to, or unauthorized use or disclosure of, the Personal Data, provided, however, that such security measures shall meet any requirements of any applicable Privacy Laws

### 8.4 Representations and Warranties

**8.4.1 Client.** Client represents and warrants to Nutrislice that (i) Client has all rights, title, and interest necessary to provide any Personal Data to Nutrislice; (ii) Client has provided all necessary notices and obtained all necessary consents from data subjects which are required to assign or grant the rights or licenses in any Client Data to Nutrislice; (iii) it has complied with all Privacy Laws; and (iv) Client Data does not infringe any data, privacy, publicity or similar rights of any third party, nor has any claim (whether or not embodied in an action, past or present) of such infringement been threatened or asserted, and no such claim is pending against Client or, to the best of Client's knowledge, against any entity from which Client has obtained such rights.

**8.4.2 Nutrislice.** Nutrislice represents and warrants to Client that (i) it has complied with all Privacy Laws; and (ii) Client Data it collects does not infringe any data, privacy, publicity or similar rights of any third party to Nutrislice's knowledge, nor has any claim (whether or not embodied in an action, past or present) of such infringement been threatened or asserted, and no such claim is pending against Nutrislice or, to the best of Nutrislice's knowledge, against any entity from which Nutrislice has obtained such rights.

**8.5 Security Breach.** In the event that Nutrislice becomes aware that any Personal Data or User Data has been disclosed by Nutrislice (or its employees, subcontractors or agents) contrary to any applicable law, security procedures or the privacy policy under which such Personal Data was collected, or Nutrislice (or its employees, subcontractors or agents) discovers, receives notice of, or suspects that unauthorized access, acquisition, disclosure or use of Personal Data or User Data has occurred or is likely to occur (a "Data Breach"), then Nutrislice shall give prompt notice to Client, with full particulars, and shall immediately commence a thorough investigation of any such incident. If applicable laws require notice to authorities or individuals, or other remedial action, or Client determines that notices or





other remedial actions are warranted, then Nutrislice shall undertake remedial action which may be necessary in Nutrislice's reasonable discretion. If any notices are to be sent to individuals or other parties, Client shall have the right, at its option, to either send the notices itself, or to approve the text of the notices to be sent by Nutrislice.

**8.6 Confidentiality and Nondisclosure.** All Personal Data disclosed or made available to Nutrislice hereunder is deemed Confidential Information, subject to all the obligations of confidentiality set forth in the Agreement, whether or not such Personal Data marked or otherwise indicated as being Confidential Information.

**8.7 Child Protection Laws.** Nutrislice may provide optional Software Services to You that facilitate the collection of information by You or on Your behalf by Nutrislice. Given that child protection and privacy laws vary by jurisdiction, You agree not to enable or use any information gathering functionality in Nutrislice Software to collect information from children unless You verify that your use of such functionality complies with local, state (or provincial), and national laws, including COPPA. You agree that You are responsible for the content of any surveys, polls, and/or input prompts that You (or Authorized Users) create and/or conduct through Nutrislice software, including making sure Your use of information-collecting functionality complies with applicable laws. You agree that any information collected by You via your instance of the Nutrislice Software is done so by Nutrislice strictly on Your behalf, to Your benefit, and under Your supervision, in accordance with COPPA. You agree to not enable or utilize any user feedback and/or information gathering functionality that is not compliant with any applicable law, or that you deem to be inappropriate.

**8.8 Passive Data Collection.** You acknowledge and authorize that in order to support the internal operations of core functionalities of Nutrislice Software and to provide the Software to You, the Software must passively collect usage data, which may include de-identified Personal Data, User Data, or non-Personal Data, including IP addresses, device ID's, and cookies. Nutrislice may submit such data to data analytics service providers with whom Nutrislice has partnered for no purpose other than to improve the Software, to support internal operations and business decisions, and to share such information with You.

## 9. TERM, RENEWAL, AND TERMINATION

**9.1 Term of Agreement.** This Agreement commences on the date You accept it and continues until the Contract End Date specified in the Order Contract; notwithstanding, this Agreement will continue to be in effect beyond the Contract End Date for the duration of any Renewal Terms that are entered into according to Section 9.2. If this Agreement is terminated for cause in accordance with Section 9.3, all Subscriptions granted herewith shall effectively terminate immediately.

### 9.2 Renewal.

**a. Renewal Subscriptions.** Unless renewal is explicitly excluded by additional terms provided in the Order Contract, the entire Order Contract including this Agreement and corresponding Subscriptions may be renewable for successive, contiguous 12-month renewal term(s) unless other renewal terms are agreed upon by the parties; notwithstanding, **renewal shall not be automatic**, shall only be available at Nutrislice's discretion, and will only occur after the following occur: (i) We affirmatively send You an updated Order Contract, proposal, quote or invoice corresponding to the renewal (a "Renewal Document"); and (ii) You agree to the Renewal Document or provide Us with payment for the renewal Subscription(s). Regardless of payment date, renewal Subscriptions will commence on the Renewal Date (or anniversary thereof) or date following the End Date, as specified in your original Order Contract. Upon renewal, the renewal Subscriptions, the original Order Contract, this Agreement and any addendums or attachments herewith, unless explicitly superseded, will remain effective and will terminate at the end of the renewal term following the Renewal Date. The same contractual obligations with respect to the initial Subscription(s) shall apply to any renewal Subscription(s), and renewal Subscriptions may only be terminated earlier than their term under the same conditions as the initial Agreement (see Section 9.3). We reserve the right to make renewal contingent upon You executing a new or updated Order Contract and/or Software Subscription Agreement, which would supersede this Agreement.

**b. Inflation and/or Pricing Increase on Renewal.** We may adjust the pricing for any renewal based on inflation or market reasons. A pricing increase upon renewal may be reflected in any proposal, invoice or updated Order Contract, with or without prior notice, in which case renewal will be contingent upon payment of the increased price.

**9.3 Termination for Cause.** This agreement may be terminated for cause under the following circumstances: (a) if a Party becomes the subject of a petition in bankruptcy or any other proceeding relating to insolvency, receivership, liquidation or assignment for the benefit of creditors, the other Party may terminate this Agreement for cause immediately; (b) We may terminate this Agreement for cause immediately if You violate Our intellectual property rights or violate your responsibilities under Section 2.2(b); (c) You may terminate this Agreement if an Error constituting a material breach as described in Section 9.4 occurs; (d) for other material breaches of this Agreement or an Order Contract, a Party may terminate this Agreement following 30 days' written notice to the other Party of the material breach, if such breach remains uncured at the expiration of such period; provided that such notice includes full



information regarding the material breach, is founded on specific material terms of this Agreement or Order Contract, and describes what, with reference to the terms of this Agreement or the Order Contract, may be done to by the other Party to cure such breach. If the Party accused of breach under subsection (c) or (d) of this paragraph disputes whether a material breach has occurred, and agreement or resolution cannot be reached between the Parties, the Parties agree to resolve the dispute according to Section 11.5, within 30 days if possible, and to delay the termination until the dispute is resolved.

**9.4 Termination for Bugs, Errors, Downtime.** Although We will make reasonable efforts to test all software prior to release, and to correct any bugs, errors, data loss and/or downtime in the Software ("Error(s)") that You bring in a reasonable and fully descriptive manner to Our attention; Errors shall not be considered a material breach nor be sufficient cause to terminate this Agreement under Section 9.3 unless: (i) the Error is sufficiently problematic to completely or substantially inhibit Your use of the Software Services; (ii) there is no reasonable work-around; (iii) You provide Us with notice that you intend to terminate this agreement if the Error is not cured, along with any information available to You regarding the Error that we request in order to evaluate or troubleshoot the Error; and (iv) We fail to remedy the Error within five (5) business days after being given such notice and full information regarding the Error. The lack of a requested feature or functionality in the software, which was not available in the Software when you purchased a Subscription thereto, shall not be deemed an Error or be sufficient grounds to terminate the agreement for cause.

**9.5 Payment upon Termination.** In no event shall any termination relieve You of the obligation to pay any fees payable to Us for the period prior to the effective date of termination.

## **10. LIMITATION OF LIABILITY**

**10.1 Limitation of Liability.** IN PROVIDING YOU WITH THE SOFTWARE SERVICES, WE ARE NOT ACCEPTING ANY RESPONSIBILITY FOR UTILIZATION OF THE SOFTWARE SERVICES OR FOR ANY DECISIONS THAT ARE MADE IN CONNECTION THEREWITH. NEITHER PARTY'S LIABILITY WITH RESPECT TO ANY SINGLE INCIDENT ARISING OUT OF OR RELATED TO THIS AGREEMENT (WHETHER IN CONTRACT OR TORT OR UNDER ANY OTHER THEORY OF LIABILITY) SHALL EXCEED THE LESSER OF \$25,000 OR THE AMOUNT PAID BY YOU HEREUNDER IN THE 12 MONTHS PRECEDING THE INCIDENT, PROVIDED THAT IN NO EVENT SHALL EITHER PARTY'S AGGREGATE LIABILITY ARISING OUT OF OR RELATED TO THIS AGREEMENT (WHETHER IN CONTRACT OR TORT OR UNDER ANY OTHER THEORY OF LIABILITY) EXCEED THE TOTAL AMOUNT PAID BY YOU HEREUNDER. THE FOREGOING SHALL NOT LIMIT YOUR PAYMENT OBLIGATIONS UNDER SECTION 3.

**10.2 Exclusion of Consequential and Related Damages.** IN NO EVENT SHALL EITHER PARTY HAVE ANY LIABILITY TO THE OTHER PARTY FOR ANY LOST PROFITS OR REVENUES OR FOR ANY INDIRECT, SPECIAL, INCIDENTAL, CONSEQUENTIAL, COVER OR PUNITIVE DAMAGES HOWEVER CAUSED, WHETHER IN CONTRACT, TORT OR UNDER ANY OTHER THEORY OF LIABILITY, AND WHETHER OR NOT THE PARTY HAS BEEN ADVISED OF THE POSSIBILITY OF SUCH DAMAGES. THE FOREGOING DISCLAIMER SHALL NOT APPLY TO THE EXTENT PROHIBITED BY APPLICABLE LAW.

## **11. MISCELLANEOUS PROVISIONS**

**11.1 Notices.** All notices required under this Agreement shall be specific, in writing, and effective upon receipt. It is Your responsibility to provide us with updated notice contact information and to verify Our receipt thereof if for any reason your contact information changes or You require that notices be addressed to different contact information than that specified in the Order Contract. Any required notice to You under this Agreement shall be sent via email or posted by certified mail or overnight courier with delivery verification capability to the contact specified in the Order Contract or other updated notice email and/or mailing address provided by You per this section. Notices to Us shall be addressed to legal@nutrislice.com or to Nutrislice, Inc., Attn: Legal, 295 Interlocken Blvd, #100 Broomfield, Colorado 80021. Telephone, facsimile and other notices do not constitute notice hereunder.

**11.2 Severability.** If for any reason this Agreement or any portion thereof is held or deemed by a court of competent jurisdiction to be invalid or unenforceable under any applicable law or equitable principle or is so held by applicable court decision, such unenforceability or invalidity will not render this Agreement unenforceable or invalid as a whole, and, in such event, such provision will be changed, enforced and interpreted so as to best accomplish the objectives of such unenforceable or invalid provision to the maximum allowable extent within the limits of applicable law, equity or applicable decisions, and the remaining provisions of this Agreement shall remain binding upon the Parties in full force and effect.

**11.3 Independent Contractors.** You and Nutrislice are independent contractors; neither Party is the partner, joint venture, agent, representative or employee of the other Party; and nothing in this Agreement will be construed to create any relationship between them other than an independent contractor relationship. Neither Party shall have any



responsibility or liability for the actions or inactions of the other Party, except as expressly provided herein. Neither Party will have any right or authority to bind or obligate the other Party in any manner or make any representation or warranty on behalf of the other Party.

**11.4 Limit on Cause of Action.** All legal or equitable action(s) arising out of this Agreement that is commenced or initiated by You shall be forever barred unless commenced within one (1) year of the act(s) or omission(s) giving rise to the right(s)/cause(s) of action. The Parties hereby expressly agree that this Section 11.4 is an express waiver by You of all applicable statutes of limitation and/or periods of liberative prescription that may be held or deemed to be applicable by any court of proper jurisdiction.

**11.5 Dispute Resolution.** Unless alternative dispute resolution is mutually agreed upon by the parties, any dispute arising under this Agreement shall be settled in a court of proper jurisdiction in Your state.

**11.6 Force Majeure.** Neither You nor We will be liable to each other or any third Party by reason of any failure or delay in the performance of our obligations hereunder on account of strikes, shortages, riots, insurrection, terrorist actions or threats, fires, flood, storms, explosions, acts of God, war (declared or undeclared), governmental action, labor conditions, earthquakes, material shortages or any other cause which is beyond the reasonable control of You or Us.

**11.7 No Waiver.** The failure of You or Us to require performance of any provision of this Agreement will not affect the full right of You or Us to require such performance at any time hereafter; nor will the waiver by You or Us of a breach of any provision hereof be taken or held to be a waiver by You or Us of that provision or of the right to demand performance by legal action, equitable action or otherwise.

**11.8 Assignment.** Neither this Agreement nor any rights or obligations of You hereunder may be assigned or transferred by You in whole or in part, whether by operation of law, equity or otherwise, without the prior written approval of Nutrislice. Nutrislice may exercise full transfer and assignment rights in any manner at its discretion and specifically may sell, pledge, mortgage, hypothecate, or grant a security interest or security right in, and/or otherwise assign its rights and responsibilities herein to a third party it deems will responsibly carry out the obligations herein that are attributed to Nutrislice.

**11.9 Survival.** The rights and obligations of the parties contained in Sections 3, 4, 5, 8, 10 and any other right, obligation or provision under this Agreement that, by its nature, should survive termination or expiration of this Agreement shall survive any termination or expiration of this Agreement or of any individual Subscriptions.

**11.10 Governing Law.** This Agreement shall be governed by the laws of Your state of domicile, without regard to its conflict of laws principles.

**11.11 Entire Agreement.** The Order Contract, this Agreement and any attachments or exhibits herewith, and any properly executed subsequent Addenda or add-on Order Contracts constitute the entire, complete and exclusive agreement between the Parties with respect to the subject matter hereof and supersede any prior or concurrent agreements between the Parties with respect to such subject matter, whether in written or oral form. Any term or condition stated in a purchase order provided by You that is additional to or inconsistent with this Agreement shall not be binding. In the event of any conflict or inconsistency between this Agreement and the terms stated in an Order Contract or Addendum, the terms of the Order Contract or Addendum shall only prevail if the same is signed by an Officer, Vice President, or Controller of Nutrislice.

ST650(P)



Display size  
**39"- 75"**



Max load  
**175lb (79kg)**

**SMARTMOUNT**

# Universal Tilt Wall Mount

FOR 39" TO 75" DISPLAYS

The SmartMount® Universal Tilt Wall Mount series offers the most versatile installation features and mounting options. Horizontal and vertical adjustment abilities allow for post installation leveling and side-to-side positioning, making it easier than ever to find the perfect TV position. Lock the tilt angle at installation to prevent tampering or moving with the IncreLok™ tilt technology. Security screws provided in the ST650 models deter tampering and theft. The open wall plate design offers total wall access, increasing the electrical and cable management options. The display can now simply be installed by a single person with the Hook-and-Hang™ system. The Easy-Glide™ adaptors hook onto the wall plate for an overall quick, simple, and secure installation.

*The ST650's adjustable viewing feature provides 15° of forward tilt and 5° backward tilt, creating the most optimal viewing angle.*

## Additional Features

- ✓ Universal mount fits displays with mounting patterns up to 742 x 405mm (29.21" W x 15.95" H)
- ✓ Adjustable 15° forward tilt and 5° backward tilt for finding the optimal viewing angle
- ✓ Easy-Grip™ ratcheting handle locks tilt angle into place
- ✓ Included IncreLok™ feature offers fixed tilt lock in 5° increments when used
- ✓ Up to 0.25" (6mm) of vertical adjustment on each universal display adaptor bracket for post-installation leveling and height adjustment fine-tuning
- ✓ Horizontal display adjustment up to 8.00" (203mm) for centering display on wall
- ✓ Mounts to wood studs, concrete, cinder block or metal studs (metal stud accessory required)
- ✓ Includes all necessary wall and display attachment hardware
- ✓ Integrated security options available
- ✓ Design is UL listed and tested to four times stated load capacity

For mounts requiring theft resistant hardware, installed with security tool (included), please purchase ST650

For mounts requiring standard hardware, installed with a Philips screwdriver, please purchase ST650P



Please visit [peerless-av.com/en-us/patents](http://peerless-av.com/en-us/patents) for patent information.

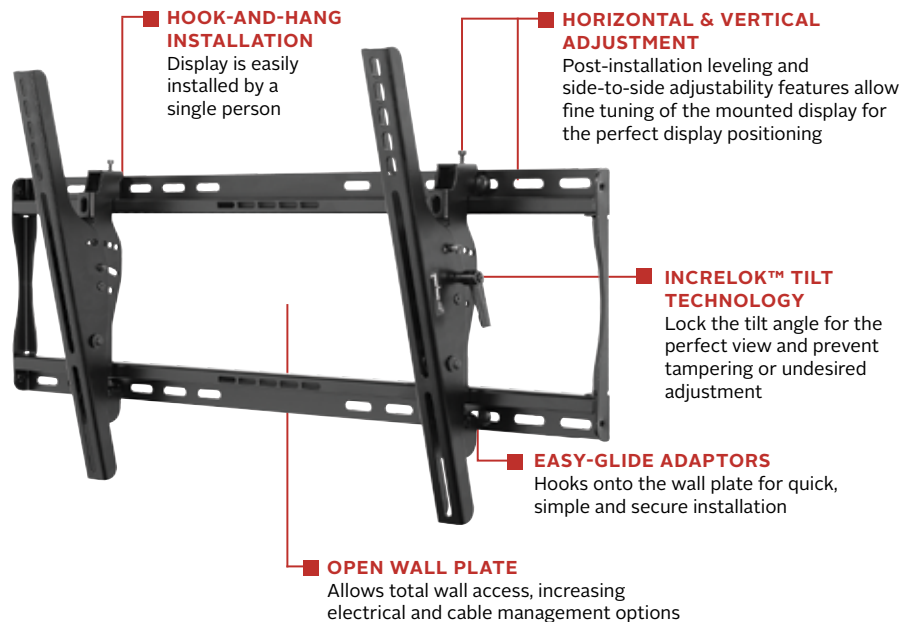

+15°/-5° of tilt for versatile viewing angles



Comes in color packaging with included installation hardware and easy to follow instructions.

## Model Numbers

**WARRANTY: Limited 5-year**

|               |   |
|---------------|---|
| <b>ST650P</b> | SmartMount® Universal Tilt Wall Mount for 39" to 75" Displays - standard models |
| <b>ST650</b>  | SmartMount® Universal Tilt Wall Mount for 39" to 75" Displays - security models |

## Product Specifications

|                 | DIMENSIONS (W x H x D)                                  | PRODUCT WEIGHT  | LOAD CAPACITY | FINISH                        | AVAILABLE COLORS |
|-----------------|---|-----------------|---------------|-------------------------------|------------------|
| <b>ST650(P)</b> | 31.26" x 16.89" x 2.62"-5.40"<br>(794 x 429 x 67-137mm) | 8.15lb (3.70kg) | 175lb (79kg)  | Scratch resistant fused epoxy | Semi-gloss black |

## Package Specifications

|                 | PACKAGE SIZE (W x H x D)                      | PACKAGE SHIP WEIGHT | PACKAGE UPC CODE                            | PACKAGE CONTENTS  | UNITS IN PACKAGE |
|-----------------|---|---------------------|---|---|------------------|
| <b>ST650(P)</b> | 33.19" x 2.95" x 10.71"<br>(843 x 75 x 272mm) | 10.35lb (4.70kg)    | ST650: 735029235941<br>ST650P: 735029235965 | Wall mount, wall and display installation hardware, installation instructions | 1                |

## Accessories

**ACC415:** Metal Stud Fastener Kit

All dimensions = inch (mm)

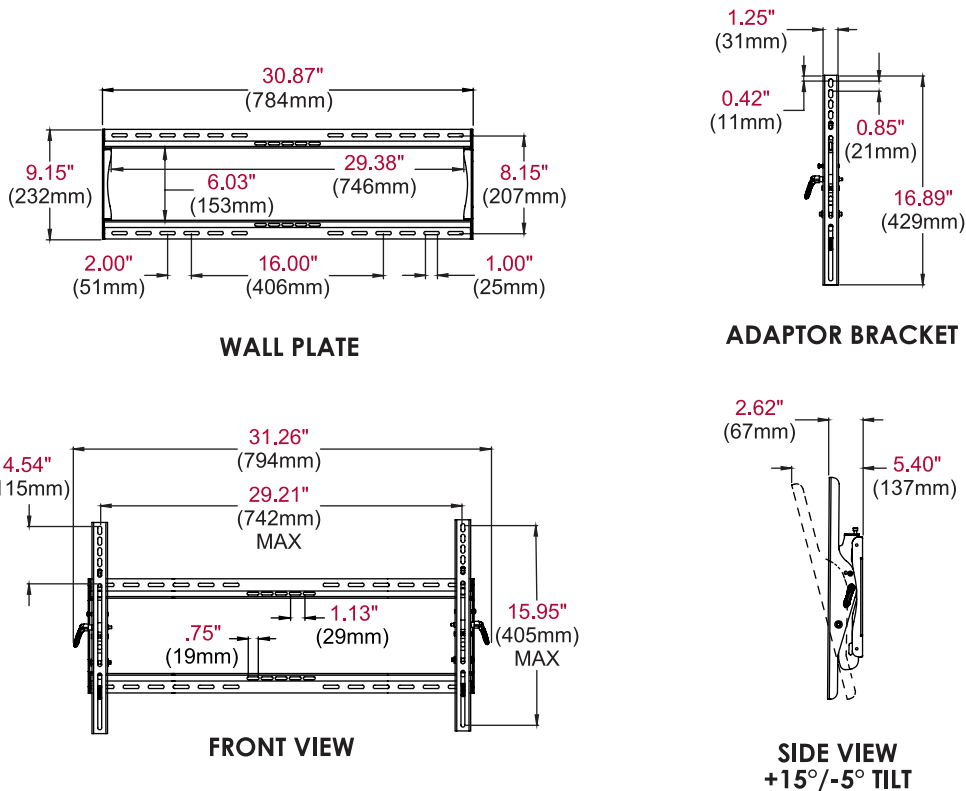

## Architect Specifications

The Smartmount® Tilt Wall Mount shall be a Peerless-AV model ST650(P) and shall be located where indicated on the plans. Assembly and installation shall be done according to instructions provided by the manufacturer.

Visit [peerless-av.com](http://peerless-av.com) to see the complete line of AV solutions from Peerless-AV, including outdoor displays, wireless, kiosks, digital audio, display mounts, projector mounts, carts/stands, and a full assortment of accessories.

**Peerless-AV**  
2300 White Oak Circle  
Aurora, IL 60502 USA  
**(800) 865-2112**  
**(630) 375-5100**  
**Fax: (800) 359-6500**

**Peerless-AV Europe**  
Unit 3 Watford Interchange  
Colonial Way, Watford  
Herts, WD24 4WP  
United Kingdom  
**+44 (0) 1923 200100**  
**Fax: +44 (0) 1923 200101**

**Peerless-AV de México**  
Ave de las Industrias 413  
Parque Industrial Escobedo  
Escobedo, N.L.,  
Mexico 66050  
**+52 (81) 8384-8300**  
**Fax: +52 (81) 8384-8360**

**peerless-AV®**

LIT-0594 Rev.6

**KEDC DIGITAL SIGNAGE AND MENU SOFTWARE PACKAGE – RFP-NUTRITION-DSS-2018**

**REQUEST FOR PROPOSAL CERTIFICATION**

We have read all the conditions and requirements of the request for proposal. In compliance with all general and specific terms and conditions of the request for proposal, in consideration of the detailed description attached hereto, and subject to the statements thereof, the undersigned agrees that, upon proper acceptance by the KEDC Board of Directors or its designee, of any part of the offer within the time stipulated, a contract shall thereby be created in accordance with the specifications for that part of the offer accepted.

**RFP CERTIFICATION**

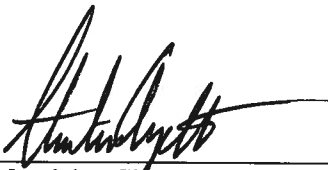
|  |   |
|--|---|
| <u>Nutrislice Inc.</u><br>Bidding Firm       | <br>Authorizing Signature |
| <u>Stanton Aydlett</u><br>Printed Name       | <u>accounting@nutrislice.com</u><br>Email Address   |
| <u>866-524-3444</u><br>Phone #               | <br>Fax #   |
| <u>295 Interlocken Blvd. #100</u><br>Address | <u>Broomfield, CO 80021</u><br>City, State, Zip   |

**RFP CLARIFICATION (Please provide contact information if the person authorized to answer questions regarding this RFP is different from above.)**

|  |   |
|--|---|
| <u>Katie Mellott</u><br>Printed Name         | <u>Katie@nutrislice.com</u><br>Email Address    |
| <u>866-524-3444</u><br>Phone #               | <br>Fax #                                       |
| <u>295 Interlocken Blvd. #100</u><br>Address | <u>Broomfield, CO 80021</u><br>City, State, Zip |

# TICKET PRINTERS



## High-Speed Ticket Printer

Star TSP743IIU-24GRY  
Part#: 39442511

*For standard non-adhesive thermal paper*

### FEATURES

- High-speed, high-reliability commercial-grade thermal printer for printing tickets and receipts
- **Speed:** 250mm/s (48 receipts per minute)
- **Paper Compatibility:**
  - 3.125" (80mm) standard (non-adhesive) thermal paper
  - 3.5" (82.5mm), and 2.25" (58mm) with Paper Guide
- **Nutrislice paper offerings:**
  - Standard white thermal paper
  - 50 3.125" x 220' rolls/case



## Self-Stick Ticket Printer

Star TSP654U GRY SK-US  
Part#: 37963020

*For self-stick and standard thermal paper*

### FEATURES

- Restickable liner-free paper option allows you to easily attach tickets to packaging and reposition, with no need for tape or adhesive
- **Speed:** 150mm/s (30 receipts per minute)
- **Paper Compatibility:**
  - 3.125" (80mm) standard (non-adhesive) OR liner-free self-stick (adhesive) thermal paper (MAXStick or equivalent)
  - 2.25" (58mm) with paper guide
- **Nutrislice Paper Offerings:**
  - White 55g side edge adhesive liner-free sticky thermal paper
  - 24 3.125" x 160' rolls/case

- **Auto-cut technology cuts between each ticket for easy bulk printing**
- **Connect to your computer using standard USB**
- **Drivers compatible with Windows 10, Windows 8.1**
- **Kit includes: Printer, Power Supply, USB Cable, and Installation Instructions**