

## Overview

### HP ProBook 6450b Notebook PC

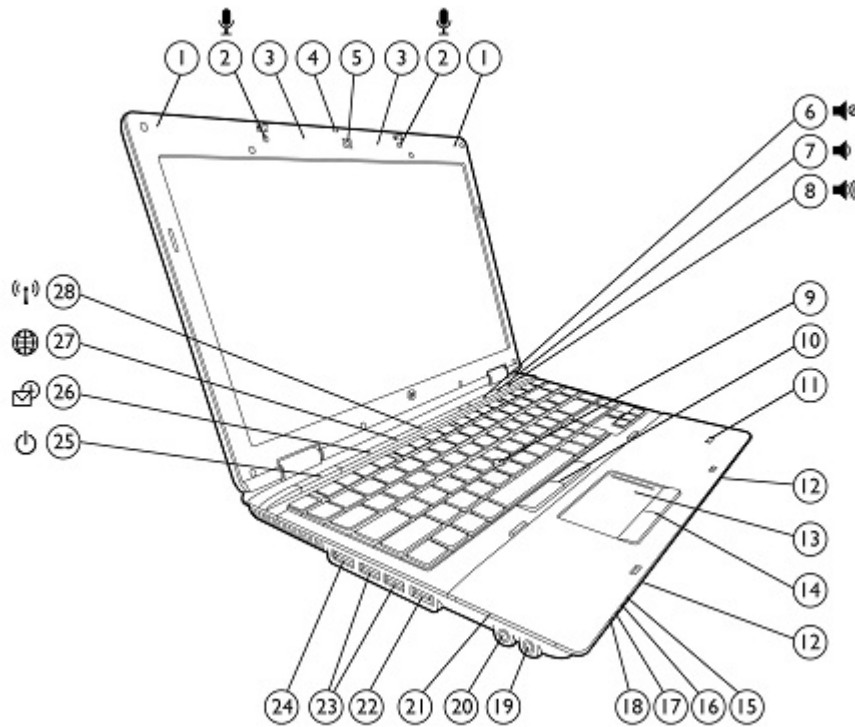

- |  |  |
|--|--|
| 1. WWAN antennas (select models)                       | 15. Hard drive activity / HP 3D DriveGuard LED indicator |
| 2. Dual-microphone array with optional webcam only*    | 16. Battery charging LED indicator                       |
| 3. WLAN antennas                                       | 17. Power/standby LED indicator                          |
| 4. Webcam LED indicator                                | 18. Wireless on/off LED indicator                        |
| 5. Optional 2 MP webcam                                | 19. Stereo headphone/line out                            |
| 6. Volume mute button with LED indicator               | 20. Stereo microphone/line in                            |
| 7. Volume down button with LED indicator               | 21. ExpressCard/54 slot or optional Smart Card Reader    |
| 8. Volume up button with LED indicator                 | 22. eSATA/USB combo port                                 |
| 9. Optional pointstick                                 | 23. (2) USB 2.0 port                                     |
| 10. Pointstick pick buttons (with optional pointstick) | 24. DisplayPort  |
| 11. Optional HP Fingerprint Sensor                     | 25. Power button with LED indicator                      |
| 12. Stereo speakers                                    | 26. QuickLook button                                     |
| 13. Touchpad with scroll zone                          | 27. QuickWeb button                                      |
| 14. Touchpad pick buttons                              | 28. Wireless on/off button with LED indicator            |

\* Models without webcam have single integrated microphone on left side of display panel.

## Overview

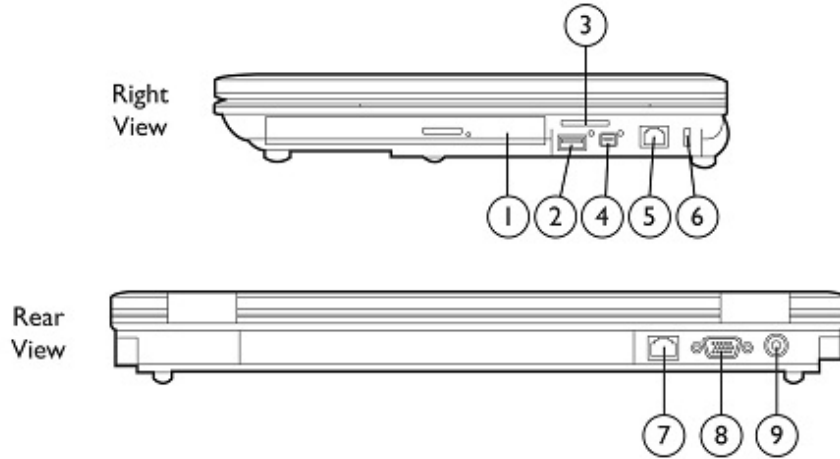

- |   |                                   |
|---|-----------------------------------|
| 1. Upgrade Bay (optical drive or second hard drive) | 6. Lock slot                      |
| 2. (1) USB 2.0 port                                 | 7. RJ-45/Ethernet port            |
| 3. Media Card Reader                                | 8. VGA/external monitor connector |
| 4. 1394a port                                       | 9. Power connector                |
| 5. RJ-11/modem port                                 |                                   |

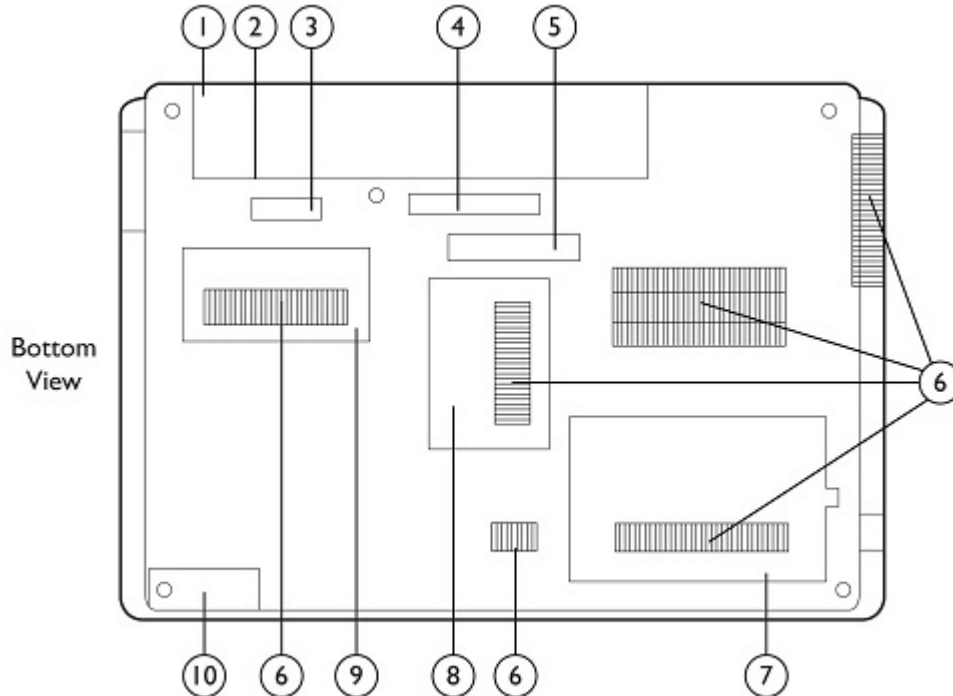

- |   |   |
|---|---|
| 1. Battery bay  | 6. Vents  |
| 2. SIM slot for WWAN (select models) – inside battery bay | 7. Hard drive bay                               |
| 3. Battery release latch                                  | 8. Memory module compartment                    |
| 4. Docking connector                                      | 9. WLAN/WWAN module compartment (select models) |
| 5. Secondary battery connector                            | 10. Bluetooth module compartment                |

## Overview

### HP ProBook 6550b Notebook PC

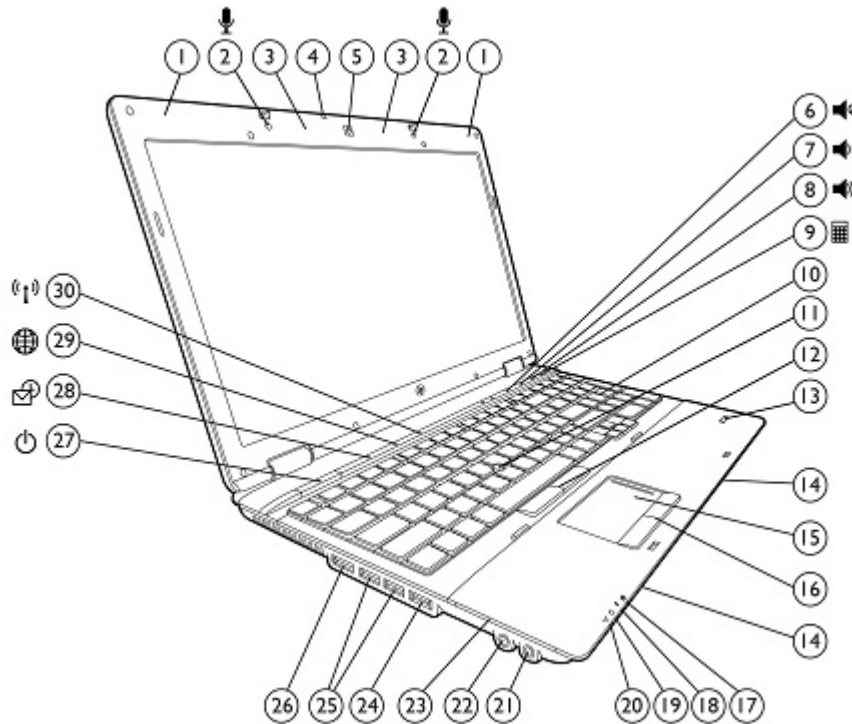

1. WWAN antennas (select models)
2. Dual-microphone array with optional webcam only\*
3. WLAN antennas
4. Webcam LED indicator
5. Optional 2 MP webcam
6. Volume mute button with LED indicator
7. Volume down button with LED indicator
8. Volume up button with LED indicator
9. Calculator button
10. Separate numeric keypad
11. Optional pointstick
12. Pointstick pick buttons (with optional pointstick)
13. Optional HP Fingerprint Sensor
14. Stereo speakers
15. Touchpad with scroll zone
16. Touchpad pick buttons
17. Hard drive activity / HP 3D DriveGuard LED indicator
18. Battery charging LED indicator
19. Power/standby LED indicator
20. Wireless on/off LED indicator
21. Stereo headphone/line out
22. Stereo microphone/line in
23. ExpressCard/54 slot or optional Smart Card Reader
24. eSATA/USB 2.0 combo port
25. (2) USB 2.0 ports
26. DisplayPort
27. Power button with LED indicator
28. QuickLook button
29. QuickWeb button
30. Wireless on/off button with LED indicator

\* Models without webcam have single integrated microphone on left side of display panel.

# QuickSpecs

HP ProBook 6450b Notebook PC  
HP ProBook 6550b Notebook PC

## Overview

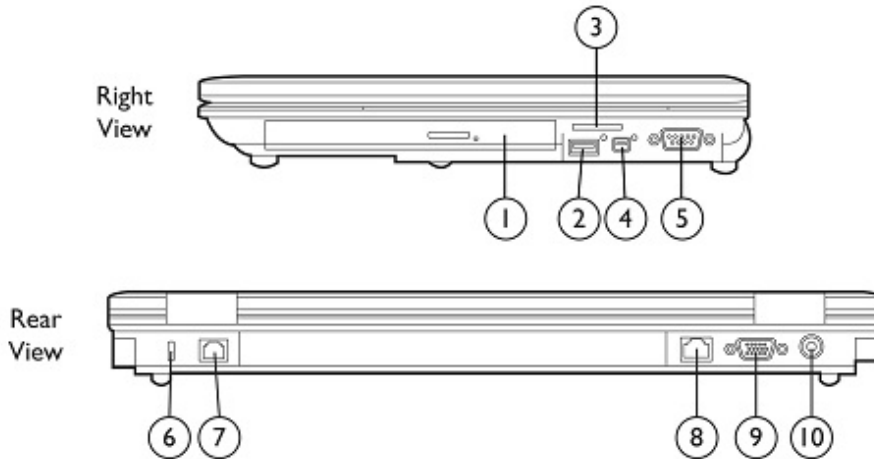

- |   |                                   |
|---|-----------------------------------|
| 1. Upgrade Bay (optical drive or second hard drive) | 6. Lock slot                      |
| 2. (1) USB 2.0 port                                 | 7. RJ-11/modem port               |
| 3. Media Card Reader                                | 8. RJ-45/Ethernet port            |
| 4. 1394a port                                       | 9. VGA/external monitor connector |
| 5. Serial port                                      | 10. Power connector               |

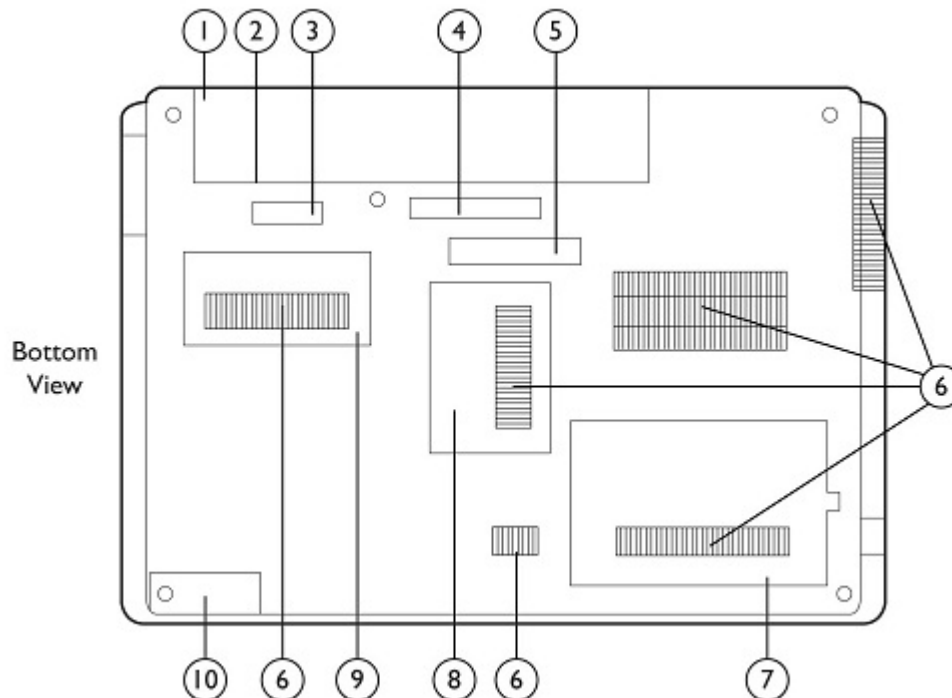

- |   |   |
|---|---|
| 1. Battery bay  | 6. Vents  |
| 2. SIM slot for WWAN (select models) – inside battery bay | 7. Hard drive bay                               |
| 3. Battery release latch                                  | 8. Memory module compartment                    |
| 4. Docking connector                                      | 9. WLAN/WWAN module compartment (select models) |
| 5. Secondary battery connector                            | 10. Bluetooth module compartment                |



## Overview

### At A Glance

- Genuine Windows 7 versions or FreeDOS
- New Intel vPro Technology for remote manageability
- Choice of Intel® Core™ i7, Core i5, or Core i3 processor
- ATI Mobility Radeon HD 540v discrete graphics with 512 MB dedicated video memory or integrated Intel HD Graphics
- Widescreen LED-backlit HD or HD+ display
  - HP ProBook 6450b: 14.0-inch diagonal; HD anti-glare
  - HP ProBook 6550b: 15.6-inch diagonal; HD anti-glare or HD+ anti-glare
- Starting at 5.0 lb/2.26 kg (6450b) or 5.5 lb/2.51 kg (6550b)
- Flexible wireless connectivity options:
  - Integrated HP un2420 EV-DO/HSPA Mobile Broadband Module provides worldwide Gobi mobile Internet technology with GPS
  - Integrated Intel Centrino® 802.11 a/b/g/n or b/g/n; Broadcom 802.11 a/b/g/n wireless LAN module
  - Bluetooth® v2.1 +EDR
- Touchpad with scroll zone; optional pointstick
- Full-sized spill-resistant keyboard with drains; full separate numeric keypad on the HP ProBook 6550b
- Touch-sensitive controls for HP QuickLook 3, HP QuickWeb, wireless on/off, mute, volume down, volume up; calculator button on HP ProBook 6550b
- Choice of 9-cell (93 WHr) or 6-cell (55 WHr & 47 WHr) primary battery, or 6-cell (51 WHr) HP Long Life Battery
- 3-cell (47 WHr) HP Long Life Battery available as after-market option
- Optional external batteries: HP Ultra-Capacity Battery, HP Extended Life Battery
- Optional integrated 2 MP Webcam with dual-microphone array
- Choice of 7200 rpm user-removable hard drive up to 320 GB with HP 3D DriveGuard protection, or 128 GB Solid State Drive
- Upgrade Bay for optical drive
- Media Card Reader
- New eSATA/USB 2.0 combo port
- Reliability with HP 3D DriveGuard, magnesium alloy support structure, HP DuraFinish, and the spill-resistant keyboard with drains
- Security features including HP ProtectTools with Central Management, Computrace LoJack Pro ready, HP SpareKey, HP Disk Sanitizer, TPM 1.2;\* optional Smart Card Reader (replaces ExpressCard slot), optional HP Fingerprint Sensor, and optional HP Privacy Filter
- HP Power Assistant allows you to conserve power, stretch battery run-time, accurately monitor your reported power need, and report workforce power consumption.
- HP QuickLook 3 for instant access to e-mail, calendar, and contacts; HP QuickWeb for fast access to the web
- HP DayStarter displays your calendar and battery charge while Windows starts up
- HP Support Assistant helps maintain your PC performance and resolve problems with automated updates and tune-ups, onboard diagnostics, and guided assistance.
- Options include HP Advanced Docking Station, HP Docking Station, HP USB 2.0 Docking Station, and HP Essential USB 2.0 Port Replicator
- BFR/PVC-free\*\*, ENERGY STAR qualified and EPEAT Gold registered in the U.S. EPEAT status varies by country- please see [epeat.net](http://epeat.net).

\* TPM module disabled where not permitted by law (for example, Russia and China).

\*\* This notebook is brominated flame retardant and polyvinyl chloride-free (BFR/PVC-free) on notebooks that are non-WWAN; meeting the evolving definition of 'BFR/PVC-free' as set forth in the "iNEMI Position Statement on the 'Definition of Low-Halogen' Electronics (BFR/CFR/PVC-Free)". Plastic parts contain < 1000 ppm (0.1%) of bromine [if the Br source is from BFRs] and < 1000 ppm (0.1%) of chlorine [if the Cl source is from CFRs or PVC or PVC copolymers]. Power supply and power cords are not BFR/PVC-free. Service parts after purchase may not be BFR/PVC-free.



Standard Features (availability may vary by country)

Processors

**Intel Dual-Core Processors**

Intel Core i7-620M Processor (2.66 GHz, 35W, 4 MB L3 cache)\*

Up to 3.33 GHz with Intel Turbo Boost Technology

Intel Core i5-540M Processor (2.53 GHz, 35W, 3 MB L3 cache)\*

Up to 3.06 GHz with Intel Turbo Boost Technology

Intel Core i5-520M Processor (2.40 GHz, 35W, 3 MB L3 cache)\*

Up to 2.93 GHz with Intel Turbo Boost Technology

Intel Core i3-350M Processor (2.26 GHz, 35W, 3 MB L3 cache)\*

\* Intel's numbering is not a measurement of higher performance.

**NOTE:** Processor speed denotes maximum performance mode; processors will run at lower speeds in battery optimization mode.

Operating System

**Preinstalled**

Genuine Windows 7 Professional Edition 32\*

Genuine Windows 7 Professional Edition 64\*

FreeDOS

**Supported**

Genuine Windows 7 Enterprise 32\*

Genuine Windows 7 Enterprise 64\*

Genuine Windows 7 Ultimate 32\*

Genuine Windows 7 Ultimate 64\*

Genuine Windows Vista Enterprise 32\*\*

Genuine Windows Vista Enterprise 64\*\*

**Certified**

SuSE Linux Enterprise Desktop 11

\* System may require upgraded and/or separately purchased hardware and/or a DVD drive to install the Windows 7 software and take full advantage of Windows 7 functionality. See <http://www.microsoft.com/windows/windows-7/> for details.

\*\* Certain Windows Vista product features require advanced or additional hardware. See: <http://www.microsoft.com/windowsvista/getready/hardwarereqs.mspx> and <http://www.microsoft.com/windowsvista/getready/capable.mspx> for details. Windows Vista Upgrade Advisor can help you determine which features of Windows Vista will run on your computer. To download the tool, visit: <http://www.windowsvista.com/upgradeadvisor>.

Chipset

Mobile Intel QM57 Express Chipset (vPro configurations)

Mobile Intel HM57 Express Chipset (non vPro configurations)

## Standard Features (availability may vary by country)

### Intel Core i5 with vPro/Core i7 with vPro technology capable

Intel Core i5 with vPro and Core i7 with vPro technology is a selectable feature that is available on units configured with an Intel Centrino® Advanced-N 6200 WLAN module and a preinstalled Windows operating system. It provides advances in remote manageability, security, energy efficient performance, and wireless connectivity. Intel Active Management Technology 6.0 (iAMT) offers built-in manageability and proactive security for networked notebook PCs, even when they are powered off\* or when the operating system is inoperable. It can help identify threats before they reach the network, isolate infected systems, and update PCs regardless of their power state.

\*Requires a Windows operating system, network hardware and software, connection with a power source, and a direct (non-VPN) corporate network connection which is either cable or wireless LAN.

**NOTE:** Some functionality of Intel Core i5 with vPro/Core i7 with vPro technology, such as Intel Active Management technology and Intel Virtualization technology, requires additional 3rd party software in order to run. Availability of future "virtual appliances" applications for Intel Core i5 with vPro/Core i7 with vPro technology is dependent on 3rd party software providers. Compatibility with future "virtual appliances" is yet to be determined.

## Graphics

Models with discrete graphics:

ATI Mobility Radeon™ HD 540v with 512 MB dedicated video memory  
Microsoft DirectX 10.1 (Shader Model 4.1) and OpenGL 2.1 capable

Models with integrated graphics:

Intel HD Graphics  
Microsoft DirectX 10 (Shader Model 4.0) and OpenGL 2.0 capable

## Display

### Internal

HP ProBook 6450b:  
14.0-inch diagonal LED-backlit HD anti-glare (1366 x 768 resolution)

HP ProBook 6550b:  
15.6-inch diagonal LED-backlit HD anti-glare (1366 x 768 resolution)  
15.6-inch diagonal LED-backlit HD+ WVA anti-glare (1600 x 900 resolution)

### External

HP Privacy Filter support

Up to 32-bit per pixel color depth

**DisplayPort** supports resolutions up to 2560 x 1600, 30-bit color depth at 60 Hz, and full HD (1920 x 1080) monitors, 24-bit color depth at 120 Hz  
**VGA** port supports resolutions up to 2048 x 1536 at 75 Hz, and lower resolutions at up to 100 Hz

**DVI-D** (single link) video signal available through DVI port in optional HP Docking Station (sold separately)

supports resolutions up to 1600 x 1200 at both full and reduced blanking, and 1920 x 1200 at reduced blanking

**NOTE:** Resolutions are dependent upon monitor capability, and resolution and color depth settings.



## Standard Features (availability may vary by country)

Memory	Standard	DDR3 PC3-10600 SDRAM (1333 MHz)* Two SODIMM slots supporting dual-channel memory 1024 MB, 2048 MB and 4096 MB SODIMMs
	Maximum Dual-channel	Upgradeable to 8192 MB with 4096 MB SODIMMs in slots 1 and 2 Maximized dual-channel performance requires SODIMMs of the same size and speed in both memory slots.

\* Memory speed is processor dependent.

**NOTE:** Due to the non-industry standard nature of some third-party memory modules, we recommend HP branded memory to ensure compatibility. If you mix memory speeds, the system will perform at the lower memory speed. Full availability of 4 GB or more of memory requires a Windows 64-bit operating system or Linux. With Windows 32-bit operating systems, the amount of usable memory is dependent upon your configuration, so that above 3 GB all memory may not be available due to system resource requirements.

---

Communications	Integrated Intel 82577LM Gigabit* Network Connection (vPro configurations) Integrated Intel 82577LC Gigabit* Network Connection (non vPro configurations) 56K V.92 modem**  * The term "10/100/1000" or "Gigabit" Ethernet indicates compliance with IEEE standard 802.3ab for Gigabit Ethernet, and does not connote actual operating speed of 1 Gb/s. For high-speed transmission, connection to a Gigabit Ethernet server and network infrastructure is required.  ** Designed for downloads from 56K modem compliant sources. Maximum achievable download transmission rates currently do not reach 56 KB/s, and will vary with line conditions. Modem availability is subject to country regulatory approval.
----------------	--

---

Wireless Devices	Support for a broad range of secure, integrated wireless LAN and wireless WAN options featuring support for the latest industry standards. Broadband Wireless (WWAN) requires a Windows operating system and is available in select countries as a standard, factory configurable feature only. Integrated Bluetooth is also available (factory configurable only) and can be combined with any of the supported wireless LAN and wireless WAN options.  <b>HP un2420 EV-DO/HSPA Mobile Broadband Module</b> Integrated mobile broadband module with Gobi global mobile Internet technology that provides connectivity to both CDMA (EVDO) and UMTS (HSPA) networks. It also provides GPS functionality for various mapping applications and security applications such as Computrace LoJack Pro Premium for HP ProtectTools.  <b>NOTE:</b> Separately purchased mobile network operator service is required. Two 850/900/1575/1800/1900/2100 MHz antennas integrated in the top of the display panel support current and future WWAN technologies.  <b>All 802.11 integrated wireless LAN options</b> Wi-Fi Certified* Cisco Compatible Extensions support Wired Equivalent Privacy (WEP) support up to 128-bit keys Wi-Fi Protected Access (WPA) and WPA2 support 802.1x authentication support, including EAP-TLS, EAP-TTLS, PEAP-GTC, PEAP-MSCHAPv2, and LEAP Advanced Encryption Standard (AES) support Dual antennas integrated in the display enclosure  <b>Intel Centrino Advanced-N 6200 (2x2)</b> Integrated support for 802.11a, b, g, and n* 2 transmit, 2 receive antennas Up to 300 mbps data rate
------------------	---





*Standard Features (availability may vary by country)*

<b>Intel Centrino Wireless-N 1000 (1x2)</b>	Integrated support for 802.11b, g, and n* 1 transmit, 2 receive antennas Up to 300 mbps data rate
<b>Broadcom 4322AGN 802.11a/b/g/n WiFi Adapter</b>	Integrated support for 802.11 a, b, g, and n Up to 300 mbps data rate
<b>Broadcom 4313GN 802.11b/g/n WiFi Adapter</b>	Integrated support for 802.11 b, g, and n Up to 72 mbps data rate
<b>Broadcom 4312G 802.11b/g WiFi Adapter (Russia/Ukraine only)</b>	Integrated support for 802.11 b and g Up to 54 mbps data rate
<b>HP Integrated Module with Bluetooth 2.1 +EDR Wireless Technology</b>	Bluetooth Specification v2.1 +EDR compliant Works with a wide range of Bluetooth devices

---

## Keyboard

The HP spill-resistant keyboard is designed using a thin layer of Mylar film under the keyboard and a drain system that funnels fluid through a hole in the bottom of the notebook. This minimizes the risk of damage to sensitive components underneath. The 101/102-key compatible keyboard features a full-pitch key layout with desktop keyboard features, such as the isolated inverted-T cursor control keys, editing keys, both left and right control and alt keys, 12 function keys, and 19.05 x 19.05 mm key pitch (center-to-center spacing). U.S. and International key layouts are available. Other features include hotkeys for instant access to power conservation and brightness. The HP ProBook 6550b includes a separate numeric keypad.

---

## Touch-sensitive controls

Touch-sensitive controls provide easy access to the following features: HP QuickLook 3, HP QuickWeb, wireless on/off, volume mute, volume down, volume up. The HP ProBook 6550b also features a calculator button.

---

## Pointing device

Touchpad with scroll zone, two pick buttons  
Optional pointstick with two additional pointstick buttons

---



## Standard Features (availability may vary by country)

Expansion card slots	ExpressCard/54 slot	Supports ExpressCard/54 and ExpressCard/34
	or	
	<b>Optional Integrated Smart Card Reader</b> (replaces ExpressCard/54 slot)	Compatible with ISO 7816 compliant Smart Cards PC/SC interface support
	<b>Media Card Reader</b>	Supports SD (Secure Digital), HC-SD (High Capacity Secure Digital), MMC (MultiMedia Card), HS-MMC (MultiMedia Card Plus), Sony Memory Stick, Sony Memory Stick Pro, Memory Stick Duo*, xD-Picture card

Additionally, the following cards are supported via passive adapters (sold separately): Mini-Secure Digital (Mini-SD), Transflash (Micro-SD), Reduced size Multimedia card (RS-MMC), Reduced size Dual voltage Multimedia card, MMC Mobile Cards, MMC Micro Cards, Memory Stick Duo (MS Duo)\*, Memory Stick Duo Pro (MS Duo Pro)\*, Memory Stick M2 Micro

\* Memory Stick Duo Adapters are required and sold separately. Inserting a Memory Stick Duo Card directly into your notebook could damage the memory card and/or notebook.

---

Internal Storage	<b>Hard drives</b>	160/250/320 GB 7200 rpm SMART SATA II 320 GB 7200 rpm SMART SATA II Self Encrypting Drive
		<b>NOTE:</b> These hard drives are customer removable and will withstand multiple insertion/removal cycles. Up to 10 GB is reserved for the system recovery software.
	<b>HP 3D DriveGuard</b> (Windows only)	The hard drive is mounted directly to the notebook frame, reducing the transmission of shock to the hard drive. Uses three-axis digital motion detection with intelligent sensitivity to help protect the hard drive during normal use from shock and vibration. The digital accelerometer temporarily halts all data transfer and parks the hard drive when abrupt motion is detected.
	<b>Solid State Drive*</b>	128 GB

\* Installation of a Solid State Drive on systems with Windows 7 requires system memory of 2 GB or more.

---

Upgrade Bay	<b>Fixed 12.7 mm SATA optical drive</b>	DVD+/-RW SuperMulti DL LightScribe Drive DVD-ROM Drive
	<b>Weight saver</b>	

## Standard Features (availability may vary by country)

Interfaces	ExpressCard/54 slot	One (or optional Smart Card Reader)
	External monitor	Two - (1) DisplayPort, (1) VGA
	1394a	One
	Stereo microphone in	One
	Stereo headphone/line out	One
	Power connector	One
	RJ-11/modem	One
	RJ-45/Ethernet	One
	USB 2.0	Three
	eSATA/USB 2.0 combo	One
	Serial port	One (HP ProBook 6550b only)
	Docking connector	One
	Secondary battery connector	One

---

## Audio/Visual

HD audio (HP Premier Sound)  
Integrated stereo speakers  
Integrated microphone (dual-microphone array when equipped with optional 2 MP webcam)  
Touch-sensitive controls for volume up, volume down, and mute  
Stereo headphone/line out  
Stereo microphone/line in

### Optional 2 MP webcam

- Supports videoconferencing and still image capture
  - Large image sensor for excellent colour matching and good low light sensitivity
  - Up to 30 frames/sec
  - Fixed focus lens
  - Video capture at VGA, 1.3 Mpixel, and 2 Mpixel resolutions
  - 16-bit true colour (camera sensors output YCrCb format among others)
-

Standard Features (availability may vary by country)

<b>Software</b>	<b>Preinstalled software with Windows operating system</b>	HP Recovery Manager (available with Windows 7 or Vista only) HP Support Assistant (available with Windows 7 or Vista only) HP ProtectTools Security Manager HP ProtectTools for Central Management HP Quick Launch Buttons Software HP QuickLook 3 HP QuickWeb HP Power Assistant HP Connection Manager 3.1 HP Wireless Assistant HP DayStarter Microsoft Office 2010 preloaded (purchase of a Product Key required to activate a full Office 2010 suite)* McAfee Total Protection* PDF Complete Special Edition** Intervideo WinDVD – DVD Player (select models) Roxio Creator Business (select models) HP Webcam Software (select models) Skype WinZip 14.5 trial
	<b>Additional software available from the web</b>	HP SoftPaq Download Manager

\* Microsoft Office 2010 Preloaded includes reduced functionality versions of Word and Excel. Purchase of Product Key required to activate full Office 2010 suite available at participating resellers/retailers and <http://www.office.com>.

\*\* 60 day trial period for McAfee Total Protection for Small Business software. Internet access required to receive updates. First update included. Subscription required for updates thereafter.

\*\*\* 60 day trial; purchase license afterwards for full functionality.

---

<b>HP Recovery Manager</b>	Models shipped with Windows 7 or Windows Vista include HP Recovery Manager. HP Recovery Manager enables fast recovery of the factory preinstalled image if the system becomes corrupted or if important system files are accidentally deleted. Up to 10 GB of the hard drive is reserved for the system recovery software.
----------------------------	--

---

## Standard Features (availability may vary by country)

Security	Standard Features	HP ProtectTools Security Manager Enhanced Pre-Boot Security HP SpareKey One-Step Logon Setup Password TPM 1.2 Embedded Security Chip* TPM Enhanced DriveLock* HP Disk Sanitizer Lock slot Support for Computrace** LoJack Pro for HP ProtectTools
	Optional Features	<b>Smart Card Reader</b> Compatible with ISO 7816 compliant Smart Cards (replaces ExpressCard/54 slot) PC/SC interface support <b>HP Fingerprint Sensor</b> Enhanced sensor scans the fingerprint to uniquely identify and authenticate a person. <b>HP Privacy Filter</b> Narrows viewing area so that screen data is visible only to persons directly in front of the monitor. <b>Computrace** LoJack Pro Premium for HP ProtectTools with GPS Tracking</b> Subscription based security solution providing the ability to track, initiate physical recovery, conduct asset management, and perform remote data delete by utilizing GPS technology. GPS functionality requires HP un2420 EV-DO/HSPA Mobile Broadband Module.

\* TPM module disabled where use is restricted by law; for example, Russia and China.

\*\* The Computrace agent is shipped turned off, and must be activated by customers when they purchase a subscription with terms ranging from one to five years.

For more information on HP security solutions refer to: <http://www.hp.com/go/security>.

### HP ProtectTools Security Manager with Central Management

HP ProtectTools Security Manager is the security platform for business notebooks and desktops. The HP ProtectTools Security Manager is an extensible client security console that delivers enhanced security capabilities through add-on software modules. The following modules are available on the hard drive (also downloadable from the web) and can be configured in Software Setup:

- Credential Manager for HP ProtectTools
- Device Access Manager for HP ProtectTools
- Drive Encryption for HP ProtectTools
- File Sanitizer for HP ProtectTools
- Privacy Manager for HP ProtectTools (Chat & Sign)
- Embedded Security for HP ProtectTools
- Computrace LoJack Pro for HP ProtectTools

HP ProtectTools is now capable of being centrally managed from a single control point. HP ProtectTools is management ready out of the box, in partnership with Digital Persona, and provides features that customers expect from a centrally managed security solution, such as user provisioning, credential reset, and system and network revocation. Central Management is available in two feature levels:

- Digital Persona Pro Enterprise: Designed for environments with Active Directory. For large businesses, as well as smaller businesses utilizing an active directory based infrastructure. Gives IT Managers the ability to create role based security policies, provision users, and create login



## Standard Features (availability may vary by country)

policies based on passwords, biometrics or smart cards. Management features also include remote credential recovery in case the user forgets the password, loses the smart card, or cannot use the fingerprint reader for any reason. In addition, advanced auditing capabilities are also built in.

- Digital Persona Workgroup Manager: Designed for environments without Active Directory. This option can be used by smaller businesses as well as workgroups within large organizations. Workgroup Manager offers features similar to Digital Persona Pro Enterprise, but without active directory integration. Workgroup activation is built into HP ProtectTools, and activation of up to 5 seats is completely free.

---

### Power Supply

Models with discrete graphics:

External 90-watt Smart AC adapter

Models with integrated graphics:

External 65-watt Smart AC adapter

Power cord included is 6-foot (1.8 meter).

Total length including external AC adapter is 12 feet (3.66 meter).

HP Fast Charge\*

\*HP Fast Charge recharges your battery up to 90% within 90 minutes when the system is off. HP Fast Charge does not apply to the 9-cell primary battery, the 12-cell Ultra-Capacity batteries, or the HP Long Life Battery.

---

### Battery

#### Primary battery

HP 9-cell (93 WHr) Li-Ion battery

HP 6-cell (55 WHr) Li-Ion battery

HP Long Life 6-cell (51 WHr) Battery\*

#### Optional HP Long Life Battery\*

3-cell (47 WHr) Li-Ion battery

#### Optional HP Extended Life Battery

8-cell (52 WHr) Li-Ion battery

#### Optional HP Ultra-Capacity Battery

12-cell (95 WHr) Li-Ion battery

\* The 3-year limited warranty on the HP Long Life Battery is only available on platforms with a 3-year system warranty. The HP Long Life Battery will carry a limited 1-year warranty on platforms with a 1-year system warranty.



Standard Features (availability may vary by country)

Battery Life

	Configurations with integrated graphics	Configurations with discrete graphics
<b>HP ProBook 6450b</b>		
<b>9-cell (93 WHr)</b>	Up to 11 hours	Up to 9 hours and 30 minutes
with optional HP Extended Life Battery	Up to 17 hours and 30 minutes	Up to 15 hours and 45 minutes
with optional HP Ultra-Capacity Battery	Up to 22 hours	Up to 19 hours and 30 minutes
<b>6-cell (55 WHr)</b>	Up to 6 hours and 30 minutes	Up to 5 hours and 45 minutes
with optional HP Extended Life Battery	Up to 13 hours and 15 minutes	Up to 12 hours
with optional HP Ultra-Capacity Battery	Up to 17 hours and 30 minutes	Up to 15 hours and 30 minutes
<b>6-cell (51 WHr) Long Life</b>	Up to 6 hours	Up to 5 hours and 15 minutes
<b>HP ProBook 6550b</b>		
<b>9-cell (93 WHr)</b>	Up to 10 hours	Up to 8 hours and 45 minutes
with optional HP Extended Life Battery	Up to 15 hours and 15 minutes	Up to 14 hours
with optional HP Ultra-Capacity Battery	Up to 20 hours and 30 minutes	Up to 18 hours
<b>6-cell (55 WHr)</b>	Up to 6 hours and 15 minutes	Up to 5 hours and 30 minutes
with optional HP Extended Life Battery	Up to 11 hours and 45 minutes	Up to 10 hours and 15 minutes
with optional HP Ultra-Capacity Battery	Up to 16 hours and 30 minutes	Up to 14 hours and 30 minutes
<b>6-cell (51 WHr) Long Life</b>	Up to 5 hours and 15 minutes	Up to 4 hours and 30 minutes

**NOTE:** Battery life will vary depending on the product model, configuration, loaded applications, features, use, wireless functionality and power management settings. The maximum capacity of the battery will naturally decrease with time and usage. See MobileMark07 battery benchmark [www.bapco.com/products/mobilemark2007](http://www.bapco.com/products/mobilemark2007) for additional details.

System Standby Time

Up to 1 week

Power Conservation

ATI PowerPlay technology  
Hibernation  
Standby  
ACPI compliance



## Standard Features (availability may vary by country)

Docking and Stands	HP 90W Docking Station
	HP 120W Advanced Docking Station
	HP USB 2.0 Docking Station
	HP Essential USB 2.0 Port Replicator
	HP Dual Hinge Notebook Stand
	HP Display & Notebook Stand
	HP Adjustable Display Stand
HP Adjustable Dual Display Stand	

**NOTE:** Some HP Docking stations may not support every feature of some HP Notebook models. Please refer to the individual docking station documentation for specific information about supported features.

---

Service and Support	HP Services offers limited 3-year, 1-year and 90-day warranty options depending on country. On-site service and warranty upgrades are also available. HP Care Pack Services extend service contracts beyond the standard warranties. To choose the right level of service for your HP product, use the HP Care Pack Services Lookup Tool at: <a href="http://www.hp.com/go/lookuptool">http://www.hp.com/go/lookuptool</a> . Additional HP Care Pack Services information by product is available at: <a href="http://www.hp.com/hps/carepack">http://www.hp.com/hps/carepack</a> .
---------------------	---

**NOTE:** Certain restrictions and exclusions apply. Consult the HP Customer Support Centre for details. <http://h20000.www2.hp.com/bizsupport/TechSupport/ProductRoot.jsp>.





# QuickSpecs

HP ProBook 6450b Notebook PC  
HP ProBook 6550b Notebook PC

Options (availability may vary by country)

<b>Memory</b>	HP 1 GB (DDR3 1333 MHz) SODIMM	AT911AA
	HP 2 GB (DDR3 1333 MHz) SODIMM	AT912AA
	HP 4 GB (DDR3 1333 MHz) SODIMM	AT913AA
<hr/>		
<b>Storage</b>	HP Upgrade Bay SATA DVD+/-RW SuperMulti DL LightScribe Drive	AK869AA
	HP 250 GB Pocket Media Drive	FE477AA
	HP External USB Drive CD/DVD R/RW	FS943AA
	HP Primary SATA 320 GB 7200 rpm Hard Drive	AS282AA
<hr/>		
<b>Expansion Solutions</b>	HP 90W Docking Station	VB041AA
	HP 120W Advanced Docking Station	NZ222AA
	HP USB 2.0 Docking Station	FQ834AA
	HP Essential USB 2.0 Port Replicator	AQ731AA
	HP Dual Hinge Notebook Stand	AW661AA
	HP Display & Notebook Stand	AW662AA
	HP Adjustable Display Stand	AW663AA
HP Adjustable Dual Display Stand	AW664AA	
<hr/>		
<b>Power</b>	HP Smart 65W Travel AC Adapter	AU155AA
	HP 90W Smart AC Adapter	ED495AA
	HP 90W Smart Combo Adapter	AJ652AA
	HP Long Life 3-Cell Battery	AU213AA
	HP 6-Cell Li-Ion Primary Battery	KU531AA
	HP 9-Cell Li-Ion Primary Battery	AT908AA
	HP Extended Life Battery	AJ359AA
	HP Ultra-Capacity Battery	AT486AA



*Options (availability may vary by country)*

<b>Carrying Cases</b>	HP Basic Carrying Case	AJ078AA
	HP Value Nylon Case	RR314AA
	HP Universal Nylon Case	RR315AA
	HP Professional Slim Top Load Case	AY530AA
	HP Executive Leather Case	RR316AA
	HP Deluxe Nylon Backpack	RR317AA
	HP Deluxe Roller Case	GD405AA
	HP Basic Backpack	AM863AA
	HP Merlot Slipcase	AU095AA
	HP Basic Messenger Carrying Case	AP355AA
	HP Professional Series Carrying Case	AT886AA
	HP Professional Series Backpack	AT887AA
	HP Professional Series Messenger	AT888AA
	HP Professional Series Designer Tote	AT889AA
	HP Professional Series Slip Case	AT890AA
	HP Elite Series Designer Tote	AT891AA
HP Elite Series Quick Case	AT892AA	

---

<b>Security</b>	HP Notebook Combination Lock	AY475AA
	HP Docking Station Cable Lock	AU656AA
	HP 14.0-inch Display Privacy Filter	AU100AA
	HP 15.6-inch Display Privacy Filter	AU103AA
	HP ExpressCard Smart Card Reader	AJ451AA

---

<b>Input/Output Devices</b>	HP PS/2 Keyboard & Mouse Bundle	RC464AA
	HP USB Keyboard & Mouse Bundle	RC465AA
	HP USB Optical Travel Mouse	RH304AA
	HP USB/PS2 Optical 2-Button Scroll Mouse	DC369A
	HP Wireless Mouse	AR085AA
	HP BT Headset	AR084AA
	HP Mobile Audio Speakers	FS944AA
	HP Mobile Productivity Bundle	AQ792AA
	HP Bluetooth ExpressCard Mouse	GK872AA
	HP Notebook Companion Projector	AX325AA
	HP Migration Cable for Windows 7	AY493AA
	HP Premium Autofocus Webcam	KQ245AA
	Premium Digital Headset	KJ270AA

---



*Options (availability may vary by country)*

<b>Miscellaneous</b>	DisplayPort To DVI-D Adapter	FH973AA
	Promo USB Graphics Adapter	NL571AT
	External USB Modem	GS023AA
	Belkin USB to Serial Adapter	EM449AA
	Notebook Multi-Purpose Cleaning Kit	BL528AA



## Memory

DDR3 PC3-10600 SDRAM (1333 MHz)\*  
Two SODIMM slots supporting dual-channel memory  
SODIMM sizes supported: 1024 MB, 2048 MB and 4096 MB

- Standard Memory**
- 1024 MB (1024 MB x 1)
  - 2048 MB (1024 MB x 2)
  - 2048 MB (2048 MB x 1)
  - 3072 MB (2048 MB + 1024 MB)
  - 4096 MB (2048 MB x 2)
  - 4096 MB (4096 MB x 1)

**Optional Memory Upgrades** Support for up to 8192 MB of memory with the installation of optional DDR3 SDRAM memory kits. Both memory slots are user-accessible. Please refer to the Hardware and Software Guide for installation procedures. Maximized dual-channel performance requires SODIMMs of the same size and speed in both memory slots.

Up to	Slot 1	Slot 2
2048 MB	1024 MB	1024 MB
3072 MB	2048 MB	1024 MB
4096 MB	2048 MB	2048 MB
4096 MB	4096 MB	Empty
8192 MB	4096 MB	4096 MB

\* Memory speed is processor dependent.

**NOTE:** This chart does not represent all possible memory configurations. Due to the non-industry standard nature of some third-party memory modules, we strongly recommend using only HP- branded memory modules to ensure compatibility. If you mix memory speeds, the system will perform at the lower memory speed. Full availability of 4 GB or more of memory requires a Windows 64-bit operating system or Linux. With Windows 32-bit operating systems, the amount of usable memory is dependent upon your configuration, so that above 3 GB all memory may not be available due to system resource requirements.

<b>Memory Upgrades</b>	HP 1 GB (DDR3 1333 MHz) SODIMM	AT911AA
	HP 2 GB (DDR3 1333 MHz) SODIMM	AT912AA
	HP 4 GB (DDR3 1333 MHz) SODIMM	AT913AA



## Storage

### Upgrade Bay Drive Support

---

	Quantity Supported	Drive Bay
DVD+/-RW SuperMulti DL LightScribe Drive	One	Upgrade Bay
DVD-ROM Drive	One	Upgrade Bay
Weight Saver	One	Upgrade Bay

---

### Internal Storage Device

---

	Quantity Supported	Drive Bay
<b>Hard Drives</b>		
320 GB 7200 rpm SMART SATA II Hard Drive	One	Dedicated hard drive bay
320 GB 7200 rpm SMART SATA II Self Encrypting Hard Drive	One	Dedicated hard drive bay
250 GB 7200 rpm SMART SATA II Hard Drive	One	Dedicated hard drive bay
160 GB 7200 rpm SMART SATA II Hard Drive	One	Dedicated hard drive bay
<b>Solid State Drive*</b>		
128 GB Solid State Drive	One	Dedicated hard drive bay

\* Installation of a Solid State Drive on systems with Windows 7 requires system memory of 2 GB or more.

## Technical Specifications

<b>System Unit</b>	<b>Dimensions (HxWxD)</b>	<p>HP ProBook 6450b: 1.33 in (at front) x 13.35 in x 9.3 in 33.8 mm (at front) x 339 mm x 236.2 mm</p> <p>HP ProBook 6550b: 1.37 in (at front) x 14.62 in x 9.76 in 34.8 mm (at front) x 371.4 mm x 248.0 mm</p>
	<b>Weight</b>	<p>HP ProBook 6450b: Starting at 5.0 lb (2.26 kg) with weight saver (no optical drive) Starting at 5.31 lb (2.39 kg) with DVD-ROM drive</p> <p>HP ProBook 6550b: Starting at 5.5 lb (2.51 kg) with weight saver (no optical drive) Starting at 5.81 lb (2.64 kg) with DVD-ROM drive</p>

**NOTE:** Height varies depending upon where on the notebook the measurement is made. Weight varies by configuration and components. Weight includes 6-cell battery and hard drive.

<b>Stand-Alone Power Requirements (AC Power)</b>	Nominal Operating Voltage	18.5 V
	Average Operating Power	Integrated graphics: 17.1 W Discrete graphics: 19.71 W
	Max Operating Power	< 65 W or < 90 W
<b>Temperature</b>	Operating	32° to 95° F (0° to 35° C) (not writing optical) 41° to 95° F (5° to 35° C) (writing optical)
	Non-operating	-4° to 140° F (-20° to 60° C)
<b>Relative Humidity</b>	Operating	10% to 90%, non-condensing
	Non-operating	5% to 95%, 101.6° F (38.7° C) maximum wet bulb temperature
<b>Shock</b>	Operating	125 G, 2 ms, half-sine
	Non-operating	200 G, 2 ms, half-sine
<b>Random Vibration</b>	Operating	0.75 grms
	Non-operating	1.50 grms
<b>Altitude (unpressurized)</b>	Operating	-50 to 10,000 ft (-15.24 to 3,048 m)
	Non-operating	-50 to 40,000 ft (-15.24 to 12,192 m)
<b>Industry Standard Certifications</b>	UL	Yes
	CSA	Yes
	FCC Compliance	Yes
	ENERGY STAR®	Select models*
	EPEAT	Registered Gold in United States**
	ICES	Yes



## Technical Specifications

GS	Yes
Australia / NZ A-Tick Compliance	Yes
CCC	Yes
Japan VCCI Compliance	Yes
KCC	Yes
BSMI	Yes
CE Marking Compliance	Yes
BNCI or BELUS	Yes
CIT	Yes
GOST	Yes
Saudi Arabian Compliance (ICCP)	Yes
SABS	Yes
UKRSERTCOMPUTER	Yes

\* Configurations of the HP ProBook 6450b and HP ProBook 6550b that are ENERGY STAR qualified are identified as HP ProBook 6450b ENERGY STAR and HP ProBook 6550b ENERGY STAR on HP websites and on [www.energystar.gov](http://www.energystar.gov).

\*\* EPEAT Registered Gold in U.S. EPEAT registration varies by country. See [www.epeat.net](http://www.epeat.net) for registration status by country.

**NOTE:** For accessibility information on HP products, please visit: <http://www.hp.com/accessibility>.

### HP 90W Smart AC Adapter

<b>Dimensions</b>	5.00 x 1.97 x 1.1 in (12.7 x 5.0 x 2.9 cm)
<b>Weight</b>	0.82 lb (370 g)
<b>Input</b>	100 to 240 VAC
	Input Efficiency 87% min at 115 VAC
	Input frequency range 47 to 63 Hz
	Input AC current 1.5 A at 90 VAC, 0.75 A at 180 VAC PFC Version
	2.4 A at 90 VAC, 1.2 A at 180 VAC NON PFC Version
<b>Output</b>	Output power 90W
	DC output 19.0V
	Hold-up time 5 msec at 115 VAC input
	Output current limit < 11A, Over voltage protection- 29V max automatic shutdown
<b>Connector</b>	3 pin/grounded, mates with interchangeable cords
<b>Environmental Design</b>	Operating temperature 32° to 104° F (0° to 40° C)
	Non-operating (storage) temperature -4° to 149° F (-20° to 65° C)
	Altitude 0 to 10,000 ft (0 to 3,048 m)
	Humidity 20% to 80%



## Technical Specifications

	Storage Humidity	10% to 90%
<b>EMI and Safety Certifications</b>	CE Mark - full compliance with LVD and EMC directives; Worldwide safety standards - IEC60950, EN60950, UL60950, Class1, SELV; Agency approvals - C-UL-US, NORDICS, DENAN, EN55022 Class B, FCC Class B, CISPR22 Class B, CCC, NOM-1 NYCE; MTBF- over 200,000 hours at 25°C ambient condition.	

<b>HP 65W Smart AC Adapter</b>	<b>Dimensions</b>	4.17 x 1.85 x 1.1 in (10.6 x 4.7 x 2.8 cm)		
	<b>Weight</b>	0.62 lb (280 g)		
	<b>Input</b>	100 to 240 VAC		
		Input Efficiency	87% min at 115 VAC	
		Input frequency range	47 to 63 Hz	
		Input AC current	1.7 A at 90 VAC, 0.85 A at 180 VAC	
	<b>Output</b>	Output power	65W	
		DC output	18.5V	
		Hold-up time	5 msec at 115 VAC input	
		Output current limit	<11A, Over voltage protection- 29V max automatic shutdown	
	<b>Connector</b>	3 pin/grounded, mates with interchangeable cords		
	<b>Environmental Design</b>	Operating temperature	32° to 104° F (0° to 40° C)	
		Non-operating (storage) temperature	-4° to 149° F (-20° to 65° C)	
		Altitude	0 to 10,000 ft (0 to 3,048 m)	
	Humidity	20% to 80%		
	Storage Humidity	10% to 90%		
<b>EMI and Safety Certifications</b>	CE Mark - full compliance with LVD and EMC directives; Worldwide safety standards - IEC60950, EN60950, UL60950, Class1, SELV; Agency approvals - C-UL-US, NORDICS, DENAN, EN55022 Class B, FCC Class B, CISPR22 Class B, CCC, NOM-1 NYCE; MTBF - over 200,000 hours at 25°C ambient condition.			

<b>Optional HP Ultra-Capacity Battery</b>	<b>Dimensions (H x W x L)</b>	1.3 x 6.0 x 10.6 in (3.33 x 15.25 x 26.88 cm)		
	<b>Weight</b>	1.77 lb (0.803 kg)		
	<b>Cells/Type</b>	12-cell Lithium-Ion		
	<b>Energy</b>	Watt-hour Capacity	95 WHr	
	<b>Temperature</b>	Operating (Charging)	32° to 113° F (0° to 45° C)	
		Operating (Discharging)	14° to 140° F (-10° to 60° C)	
		Non-operating	-4° to 140° F (-20° to 60° C)	
	<b>Battery Re-Charge Time</b>	Smart Adapter	3 to 4 hours	
		System ON	4 to 5 hours (depending on system power consumption)	
	<b>Fuel Gauge</b>	When pressed, LEDs light indicating level of charge remaining on battery		





## Technical Specifications

<b>Optional HP Extended Life Battery</b>	<b>Dimensions (H x W x L)</b>	1.0 x 3.9 x 8.7 in (2.5 x 10.0 x 22.0 cm)		
	<b>Weight</b>	1.00 lb (0.455 kg)		
	<b>Cells/Type</b>	8-cell Lithium-Ion		
	<b>Energy</b>	Watt-hour Capacity	52 WHr	
	<b>Temperature</b>	Operating (Charging)	32° to 113° F (0° to 45° C)	
		Operating (Discharging)	14° to 140° F (-10° to 60° C)	
		Non-operating	-4° to 140° F (-20° to 60° C)	
	<b>Battery Re-Charge Time</b>	System in OFF mode or Standby	3 hours	
		System ON	3 to 5 hours (depending on system power consumption)	
		HP Fast Charge Technology	Charges the battery up to 90% within 90 minutes when system is OFF	
<b>Fuel Gauge</b>	When pressed, LEDs light indicating level of charge remaining on battery			

<b>Optional HP Long Life 3-cell 47 WHr Lithium-Ion Battery</b>	<b>Dimensions (H x W x L)</b>	0.8 x 2.1 x 8.0 in (2.0 x 5.3 x 20.4 cm)		
	<b>Weight</b>	0.71 lb (0.32 kg)		
	<b>Cells/Type</b>	3-cell Lithium-Ion		
	<b>Energy</b>	Watt-hour Capacity	47 WHr	
	<b>Temperature</b>	Operating (Charging)	32° to 113° F (0° to 45° C)	
		Operating (Discharging)	14° to 140° F (-10° to 60° C)	
		Non-operating	-4° to 140° F (-20° to 60° C)	
	<b>Battery Re-Charge Time</b>	System in OFF mode or Standby	2.5 hours	
System ON		3 to 5 hours (depending on system power consumption)		
HP Fast Charge Technology		Charges the battery up to 90% within 90 minutes when system is OFF		

<b>HP Long Life 6-cell 51 WHr Lithium-Ion Primary battery</b>	<b>Dimensions (H x W x L)</b>	0.8 x 2.1 x 8.0 in (2.0 x 5.3 x 20.3 cm)		
	<b>Weight</b>	0.73 lb (0.331 kg)		
	<b>Cells/Type</b>	6-cell Lithium-Ion		
	<b>Energy</b>	Watt-hour Capacity	51 WHr	
	<b>Temperature</b>	Operating (Charging)	32° to 113° F (0° to 45° C)	
		Operating (Discharging)	14° to 140° F (-10° to 60° C)	
		Non-operating	-4° to 140° F (-20° to 60° C)	
	<b>Battery Re-Charge Time</b>	System in OFF mode or Standby	2.5 hours	
System ON		3 to 5 hours (depending on system power consumption)		



## Technical Specifications

9-Cell (93 WHr) Lithium-Ion battery	Dimensions (H x W x L)	0.8 x 2.9 x 8.3 in (2.0 x 7.3 x 21.0 cm)		
	Weight	1.07 lb (0.488 kg)		
	Cells/Type	9-cell Lithium-Ion		
	Energy	Watt-hour Capacity	93 WHr	
	Temperature	Operating (Charging)	32° to 113° F (0° to 45° C)	
		Operating (Discharging)	14° to 140° F (-10° to 60° C)	
		Non-operating	-4° to 140° F (-20° to 60° C)	
Battery Re-Charge Time	System in OFF mode or Standby	3 to 4 hours		
	System ON	4 to 6 hours (depending on system power consumption)		

6-Cell (55 WHr) Lithium-Ion battery	Dimensions (H x W x L)	0.8 x 2.1 x 8.0 in (2.0 x 5.3 x 20.4 cm)		
	Weight	0.71 lb (0.32 kg)		
	Cells/Type	6-cell Lithium-Ion		
	Energy	Watt-hour Capacity	55 WHr	
	Temperature	Operating (Charging)	32° to 113° F (0° to 45° C)	
		Operating (Discharging)	14° to 140° F (-10° to 60° C)	
		Non-operating	-4° to 140° F (-20° to 60° C)	
Battery Re-Charge Time	System in OFF mode or Standby	2.5 hours		
	System ON	3 to 5 hours (depending on system power consumption)		
	HP Fast Charge Technology	Charges the battery up to 90% within 90 minutes when system is OFF		

## Displays



## Technical Specifications

15.6-inch LED HD (1366 x 768) anti-glare	Active Area (W x H)	13.54 x 7.59 in (34.4 x 19.4 cm)	
	Diagonal Size	15.6 in (39.6cm)	
	Surface Treatment	Anti-glare	
	Contrast Ratio	300:1 (typical)	
	Refresh Rate	60 Hz	
	Brightness	200 nit (typical)	
	Pixel Resolution	Pitch	0.252 mm
		Format	1366 x 768
		Configuration	RGB Stripe
	Backlight	LED	
PPI	100 ppi		
Viewing Angle	±30° Horizontal, ±10° Vertical (minimum) 30/30/20/10 (Left/Right/Down/Up) (minimum) or 45/45/35/25 (Left/Right/Down/Up) (typical)		

---

15.6-inch LED HD+ WVA (1600 x 900) anti-glare	Active Area (W x H)	13.54 x 7.59 in (34.4 x 19.4 cm)	
	Diagonal Size	15.6 in (39.6 cm)	
	Surface Treatment	Anti-glare	
	Contrast Ratio	300:1 (typical)	
	Refresh Rate	60 Hz	
	Brightness	200 nit (typical)	
	Pixel Resolution	Pitch	0.215 mm
		Format	1600 x 900
		Configuration	RGB Stripe
	Backlight	LED	
PPI	118 ppi		
Viewing Angle	±60° Horizontal, ± 50° Vertical (minimum) or ±70° Horizontal, ±60° Vertical (typical)		

---

## Technical Specifications

14.0-inch LED HD (1366 x 768) anti-glare	Active Area (W x H)	12.74 x 7.56 in (32.4 x 19.2 cm)	
	Diagonal Size	14.0 in (35.6cm)	
	Surface Treatment	Anti-glare	
	Contrast Ratio	400:1 (typical)	
	Refresh Rate	60 Hz	
	Brightness	200 nit (typical)	
	Pixel Resolution	Pitch	0.227 mm
		Format	1366 x 768
		Configuration	RGB Stripe
	Backlight	LED	
PPI	112 ppi		
Viewing Angle	$\pm 30^\circ$ Horizontal, $\pm 10^\circ$ Vertical (minimum)		
	30/30/20/10 (Left/Right/Down/Up) (minimum) or 45/45/35/25 (Left/Right/Down/Up) (typical)		

## Internal Storage

128 GB 2.5-inch SATA Solid State Drive	Weight	80.1 Grams	
	Capacity	128 GB	
	Height	0.37 in (9.5 mm)	
	Width	2.75 in (70 mm)	
	Interface	SATA	
	Performance	Maximum Sequential Read	220 MB/s
		Maximum Sequential Write	200 MB/s
	Logical Blocks	250,069,680	
	Operating Temperature	32° to 158°F (0° to 70°C) [case temp]	
	Features	ATA Security; ATA-7 ;SATA 2.6; DIPM	



## Technical Specifications

320 GB 7200 rpm SATA Hard Drive	Drive Weight	0.25 lbs (115 g)	
	Capacity	320 GB	
	Height	0.37 in (9.5 mm) or on some models 0.28 in (7 mm)	
	Width	2.75 in (70 mm)	
	Interface	ATA-8, SATA 2.6, 3.0 Gb/s, NCQ	
	Transfer Rate	<b>Synchronous</b> (maximum) 100 MB/s (Drive Capability)	
	Seek Time (typical reads, including settling)	<b>Single Track</b>	1.5 ms
		<b>Average</b>	11 ms
		<b>Maximum</b>	22 ms
	Rotational Speed	7200 rpm	
	Logical Blocks	625,142,448	
	Operating Temperature	32° to 140° F (0° to 60° C) [case temp]	
	Features	ATA Security	

---

250 GB 7200 rpm SATA Hard Drive	Drive Weight	0.25 lbs (115g)	
	Capacity	250 GB	
	Height	0.37 in (9.5 mm) or on some models 0.28 in (7 mm)	
	Width	2.75 in (70 mm)	
	Interface	ATA-8, SATA 2.6, 3.0 Gb/s, NCQ	
	Transfer Rate	<b>Synchronous</b> (maximum) 100 MB/s (Drive Capability)	
	Seek Time (typical reads, including settling)	<b>Single Track</b>	1.5 ms
		<b>Average</b>	11 ms
		<b>Maximum</b>	22 ms
	Rotational Speed	7200 rpm	
	Logical Blocks	488,397,168	
	Operating Temperature	32° to 140° F (0° to 60° C) [case temp]	
	Features	ATA Security	

---

## Technical Specifications

160 GB 7200 rpm SATA Hard Drive	Drive Weight	0.25 lb (115 g)	
	Capacity	160 GB	
	Height	0.37 in (9.5 mm)	
	Width	2.75 in (70 mm)	
	Interface	ATA-8, SATA 2.6, 3.0 Gb/s, NCQ	
	Transfer Rate	<b>Synchronous</b> (maximum)	100 MB/s (Drive Capability)
	Seek Time (typical reads, including settling)	<b>Single Track</b>	1.5 ms
		<b>Average</b>	11 ms
		<b>Maximum</b>	22 ms
	Rotational Speed	7200 rpm	
	Logical Blocks	312,581,808	
	Operating Temperature	32° to 140° F (0° to 60° C) [case temp]	
Features	ATA Security		
<hr/>			
DVD-ROM Drive	Access Times	Random	< 110 ms CD (typical) < 110 ms DVD (typical)
	Max Data Transfer Rate	24X CD-ROM	Up to 3,600 KB/s
		8X-DVD	Up to 10,800 KB/s
	Transfer Mode	UDMA Mode 5	
	Interface	Gen 1 SATA	
	Supported Media (read)	CD-DA, CD+(E)G, CD-MIDI, CD-TEXT, CD-ROM, CD-ROM XA, MIXED MODE CD, CD-I, CD-I Bridge (Photo-CD, Video CD), Multisession CD (Photo-CD, CD-EXTRA, Portfolio, CD-R, CD-RW), CD-R, CD-RW, DVD-ROM (DVD-5, DVD-9, DVD-10, DVD-18), DVD-R, DVD-RW, DVD+R, DVD+RW, DVD-RAM	
	Supported Media (write)	None	
	Max Media Capacity (read)	8.5 GB	
	Transport	Tray Loading	
<hr/>			



## Technical Specifications

DVD+/-RW SuperMulti DL LightScribe Drive	<b>Access Times</b>	Random	< 150ms CD (typical) < 160 ms DVD (typical)
	<b>Max Data Transfer Rate</b>	24X CD-ROM	Up to 3,600 KB/s
		8X DVD	Up to 10,800 KB/s
		24X CD-R	Up to 3,600 KB/s
		16X CD-RW	Up to 2,400 KB/s
		8X DVD+R	Up to 10,800 KB/s
		8X DVD+RW	Up to 10,800 KB/s
		8X DVD-R	Up to 10,800 KB/s
		6X DVD-RW	Up to 8100KB/s
		4X - DVD+R Dual Layer	Up to 5,400 KB/s
		4X - DVD-R Dual Layer	Up to 5,400 KB/s
	5X DVD-RAM	Up to 6,750 KB/s	
	<b>Transfer Mode</b>	UDMA Mode 5	
	<b>Interface</b>	Gen 1 SATA	
<b>Supported Media (read)</b>	CD-DA, CD+(E)G, CD-MIDI, CD-TEXT, CD-ROM, CD-ROM XA, MIXED MODE CD, CD-I, CD-I Bridge (Photo-CD, Video CD), Multisession CD (Photo-CD, CD-EXTRA, Portfolio, CD-R, CD-RW), CD-R, CD-RW, DVD-ROM (DVD-5, DVD-9, DVD-10, DVD-18), DVD-R, DVD-RW, DVD+R, DVD+RW, DVD-RAM		
<b>Supported Media (write)</b>	CD-R, CD-RW, DVD+R, DVD+RW, DVD-R, DVD-RW, DVD-RAM, LightScribe		
<b>Max Media Capacity (read)</b>	8.5 GB		
<b>Max Media Capacity (write)</b>	8.5 GB		
<b>Transport</b>	Tray Loading		

## Audio

Hardware	<b>Implementation</b>	IDT 92HD75B High Definition CODEC
	<b>Touch-Sensitive Volume Controls</b>	Volume up, volume down, and mute
	<b>Full Duplex</b>	Yes
	<b>Microphone In</b>	Stereo
	<b>Headphone/Line Out</b>	Stereo
	<b>Integrated Microphone</b>	Yes, one microphone on configurations without optional webcam; dual-microphone array when equipped with optional webcam



## Technical Specifications

---

Audio Output Quality	Frequency Response	20 Hz – 20 kHz
	Signal to Noise Ratio	>85 dB
	Total Harmonic Distortion	0.01%
	Noise Floor	-110 dB
	Play/Record Sampling Rate(s)	8 kHz – 48kHz
	DAC	16, 20 or 24-bit
	ADC	16 or 20-bit

---

Integrated Stereo Speakers	Power Rating	2 Watts
	Impedance	4 Ohms

---

## Security

---

HP Fingerprint Sensor (optional)	Mobile Voltage Operation	3.0V-3.6V Single Supply
	Operating Temperature	32° - 158°F (0° - 70°C)
	Current Consumption @ 3.3V	Less than 70 mA peak imaging and scrolling Less than 25 mA hardware finger detection Advanced Power Management
	High-Rate Image Capture	Up to 240 image frames /sec
	ESD Resistance	IEC 61000-4-2 Level 4 (±15KV)
	Detection Matrix	192 x 16 Pixels
		9.7 mm x 0.81 mm 500 ppi High-Resolution Images

---

## Communications

---





## Technical Specifications

<b>Integrated Intel Gigabit Network Connection</b> (10/100/1000 NIC)	<b>Ethernet Features</b>	10 Mbit/s operation (10BASE-T; IEEE 802.3i; IEEE 802.3 clauses 13-14) 100 Mbit/s operation (100BASE-TX; IEEE 802.3u; IEEE 802.3 clauses 21-30) 1000 Mbit/s operation (1000BASE-T; IEEE 802.3z and 802.3ab; IEEE 802.3 clauses 34-42) Auto-Negotiation (Automatic Speed Selection) Full Duplex Operation at all Speeds, Half Duplex operation at 10 and 100 Mbit/s IEEE 802.1p QoS (Quality of Service) Support IEEE 802.3x Flow Control (IEEE 802.3 clauses 31-32; configurable)
82577LM	<b>Power Management</b>	ACPI compliant – multiple power modes Situation-sensitive features reduce power consumption
	<b>Performance Features</b>	TCP/IP/UDP Checksum Offload (configurable)
	<b>Manageability</b>	Wake-on-LAN from standby and hibernation (Magic Packet and Microsoft Wake-Up Frame); Wake-on-LAN from off (Magic Packet only) PXE 2.1 Remote Boot Statistics Gathering (SNMP MIB II, Ethernet-like MIB, Ethernet MIB (802.3x, clause 30)) Comprehensive diagnostic and configuration software suite Intel Advanced Management Technology 6.0 (iAMT)
	<b>Interface</b>	PCI Express x1 based, SMBUS dedicated connection with Intel® 5 Series Chipset
	<b>NIC Device Driver Name</b>	Intel 82577 Gigabit Network Connection

---

<b>V.92 56K Data/Fax Modem</b>	<b>Form Factor</b>	MDC 1.5 Daughtercard
	<b>Power Management Support</b>	APM Revision 1.2, ACPI
	<b>Approvals/Certifications</b>	UL, CSA, NEMKO, CCIB, Industry Canada, FCC Part 68, CTR21, FCC Part 15 Class B, Canadian ICES-003 Class B, C.I.S.P.R.22, Australian ACA, CE Mark, Other Countries
	<b>Data Mode Capabilities</b>	V.92 data V.8bis V.80 V44, V.42bis, MNP5 (Compression) V.42 (LAPM, MNP2-4) (Error Correction) <b>Optional symbol rates:</b> 2800, 3429 Asymmetric Symbol rates <b>Synchronous primary channel data signaling rates:</b> 3600, 31200 Automatic rate re-negotiation V.34 V.32bis V.32 V.23 V.22bis V.22



## Technical Specifications

	V.21
	Bell 212A
	Bell 103J
<b>Fax Mode Capabilities</b>	TIA/EIA-578-B (Class 1) T.30, T.4 (Group 3)
	V.17
	V.29
	V.27ter
	V.21 Channel 2
<b>Command Set</b>	V.250 (Partial)
	TIA-602
	Identification: +GMI, +GMM, +GMR
	Port control: +IPR, +ICF, +IFC, +ILRR
	Modulation: +MS, +MR, +MA
	Error control: +ES, +ER, +EB, +ESR, +ETBM
	Data compression: +DS, +DR
	V.251

<b>HP un2420 EV-DO/HSPA Mobile Broadband Module</b>	<b>Technology/Operating Bands</b>	GSM/GPRS/EDGE: 850MHz(Cell), 900MHz(EGSM), 1800MHz(DCS), 1900MHz (PCS) UMTS/WCDMA with receive diversity: 2100MHz (UTRA FDD Band I), 1900MHz (UTRA FDD Band II), 900MHz (UTRA FDD Band VIII), 850MHz (UTRA FDD Band V) 1xEVDO/1xRTT with receive diversity: 850MHz (Band Class0-Cell), 1900MHz (Band Class1-PCS)
	<b>Wireless Protocol Standards</b>	GSM/GPRS/EDGE: Class B, Multi-slot operation, coding schemes CS1 – CS4 and MSC1 – MSC9. UMTS/WCDMA: Release 99 and Release 6 CDMA: 1xEVDO Release 0 and Release A, IS-95A, IS-95B, IS-2000
	<b>Wireless Parametric Standards</b>	Meets or exceeds TIA/EIA IS-98-D
	<b>Maximum Data Rates</b>	UMTS (HSPA) – 7.2 Mbps (Download ), 2.0 Mbps (Upload) CDMA (EVDO Release A) – 3.1 Mbps (Download), 1.8 Mbps (Upload)
	<b>GPS</b>	Standalone GPS enabled
	<b>GPS Bands</b>	L1 – 1575.42 MHz
	<b>Maximum Output Power</b>	GSM/GPRS/EDGE: 32dBm (+/-1) WCDMA: 24dBm (+/-1) CDMA: 24dBm (+/-1)
	<b>Maximum Power Consumption</b>	2500mA (peak); 1000mA (average)
	<b>Power Consumption, Sleep Mode</b>	5 mA
	<b>Power Management</b>	USB selective suspend Integrated notebook wireless button
	<b>Antenna Type</b>	Dual high efficiency 5 band antennae with spatial diversity, mounted in the display enclosure
	<b>Form Factor</b>	PCI-Express MiniCard, USB 2.0 interface
	<b>Weight</b>	11.5 g



## Technical Specifications

<b>Dimensions</b> (Length x Width x Thickness)	2.01 x 1.18 x 0.18 in (51 x 30 x 5 mm)
<b>Voltage, Operating</b>	3.3v +/- 10%
<b>Temperature, Operating</b> (from TIA/EIA/IS-98-D)	-22° to 140° F (-30° to 60° C) (full RF performance) -22° to 167° F (-30° to 75° C) (reduced RF performance)
<b>Temperature, Non-operating, 96 hours</b> (from MIL-STD 202 Method 108)	-40° to 185° F (-40° to 85° C)
<b>Humidity, Non-operating</b>	85% relative humidity for 48 hours @ 185° F (85° C) (non-condensing)
<b>Configuration Utilities</b>	HP Connection Manager
<b>LED Activity</b>	LED Off – Radio Off; Solid LED On – Radio On

---

<b>Intel Centrino Advanced-N 6200 (2x2)</b>	<b>Wireless LAN Standards</b>	IEEE 802.11a IEEE 802.11b IEEE 802.11g IEEE 802.11n*  * In countries where 802.11n is not allowed, this capability is not enabled.
	<b>Interoperability</b>	Wi-Fi certified Cisco Compatible Extensions Program compliant with Microsoft Windows Vista and XP
	<b>Frequency Band</b>	2.4 GHz and 5GHz
	<b>Antenna Structure</b>	2 transmit; 2 receive (2x2)
	<b>Data Rates</b>	802.11a: 6, 9, 12, 18, 24, 36, 48, 54 Mbps 802.11b: 1, 2, 5.5, 11 Mbps 802.11g: 6, 9, 12, 18, 24, 36, 48, 54 Mbps 802.11n: 66 possible data rates, ranging from 6 Mbps to 300 Mbps, depending on the combination of Bandwidth, Modulation Coding Scheme, and Guard Interval used, as defined in IEEE 802.11n specification
	<b>Modulation</b>	Direct Sequence Spread Spectrum DBPSK, DQPSK, CCK, OFDM, BPSK, QPSK, 16-QAM, 64-QAM
	<b>Security<sup>1</sup></b>	Authentication: WPA and WPA2, 802.1x (EAP_TLS, TTLS, PEAP, LEAP, EAP-FAST)  Authentication Protocols: PAP, CHAP, TLS, GTC, MS-CHAP, MS-CHAPv2  Encryption: 64 and 128-bit WEP, AES-CCMP, CKIP, TKIP  Support for Cisco Security Features (proven compatibility with Cisco Aironet infrastructure products through the Cisco Compatible Extensions Program Version 4) with Microsoft Windows Vista and XP only.
	<b>Sub-channels</b>	Multinational support with frequency bands and channels compliant to local regulations.
	<b>Media Access Protocol</b>	CSMA/CA (Collision Avoidance) with ACK
	<b>Network Architecture Models</b>	Ad-hoc (Peer to Peer) Infrastructure (Access Point Required)



## Technical Specifications

<b>Roaming</b>	IEEE 802.11 compliant roaming between 2.4GHz band Access Points
<b>Output Power</b> (for CCK and OFDM) <sup>2</sup>	17 dBm max
<b>Power Consumption</b>	Transmit: 2.3 Watts (average, with one spatial streams) Receive: 1 Watt (max with two spatial streams) Idle mode <sup>3</sup> : 35 mW (average) Radio off: 20 mW (max)
<b>Power Management</b>	ACPI compliant power management 802.11 compliant power saving mode
<b>Receiver Sensitivity</b> <sup>4</sup>	54 Mbps: -76 dBm, 6 Mbps: -92 dBm
<b>Antenna Connections</b>	2 U.FL type connectors, 50 ohm nominal impedance
<b>Form Factor</b>	PCI-Express Half-MiniCard
<b>Weight</b>	0.0075 lb (3.4 g)
<b>Dimensions</b>	0.12 x 1.06 x 1.18 in (3.1 x 26.8 x 30.0 mm)
<b>Operating Voltage</b>	3.3V +/- 9%
<b>Temperature</b>	Operating 32° to 176° F (0° to 80° C) Non-operating -40° to 176° F (-40° to 80° C)
<b>Humidity</b>	Operating 10% to 90% (non-condensing) Non-operating 5% to 90% (non-condensing)
<b>Altitude</b>	Operating 0 to 10,000 ft (3,048 m) Non-operating 0 to 50,000 ft (15,240 m)
<b>Configuration Utility</b> <sup>5</sup>	Microsoft Windows XP Choice of Configuration Utility: <ul style="list-style-type: none"><li>● Microsoft Windows XP Wireless Network Connection Manager</li><li>● Intel PROSet for Microsoft Windows XP (required for Cisco Compatible Extensions support)</li></ul> Microsoft Windows Vista <ul style="list-style-type: none"><li>● Microsoft Windows Vista Wireless Network Connection Manager.</li><li>● Intel IHV extensions for Windows Vista available to support Cisco Compatible Extensions.</li></ul>
<b>LED Activity</b>	LED Off – Radio OFF; Solid LED On – Radio ON <ol style="list-style-type: none"><li>1. Check latest software/driver release for updates on supported security features.</li><li>2. Maximum output power may vary by country according to local regulations.</li><li>3. In Power Save Polling mode and on battery power.</li><li>4. Receiver sensitivity is measured at a packet error rate of 8% for 802.11b (CCK modulation) and a packet error rate of 10% for 802.11a/g (OFDM modulation).</li><li>5. WLAN supplier's client utility is required for Cisco Compatible Extensions support with Microsoft Windows XP. WLAN may also be compatible with certain third-party software supplicants. WLAN supplier IHV extensions required for Cisco Compatible Extensions support for Microsoft Windows Vista.</li></ol>

---

Intel Centrino Wireless-N 1000	Wireless LAN Standards	IEEE 802.11b IEEE 802.11g IEEE 802.11n*
--------------------------------	------------------------	---



## Technical Specifications

\* In countries where 802.11n is not allowed, this capability is not enabled.

<b>Interoperability</b>	Wi-Fi certified Cisco Compatible Extensions Program compliant with Microsoft Windows Vista and XP
<b>Frequency Band</b>	2.4 GHz
<b>Antenna Structure</b>	1 transmit; 2 receive (1x2)
<b>Data Rates</b>	802.11b: 1, 2, 5.5, 11 Mbps 802.11g: 6, 9, 12, 18, 24, 36, 48, 54 Mbps 802.11n: many possible data rates, ranging from 6 Mbps to 300 Mbps, depending on the combination of Bandwidth, Modulation Coding Scheme, and Guard Interval used, as defined in IEEE 802.11n specification
<b>Modulation</b>	Direct Sequence Spread Spectrum DBPSK, DQPSK, CCK, OFDM, BPSK, QPSK, 16-QAM, 64-QAM
<b>Security<sup>1</sup></b>	Authentication: WPA and WPA2, 802.1x (EAP_TLS, TTLS, PEAP, LEAP, EAP-FAST)  Authentication Protocols: PAP, CHAP, TLS, GTC, MS-CHAP, MS-CHAPv2 Encryption: 64 and 128-bit WEP, AES-CCMP, CKIP, TKIP  Support for Cisco Security Features (proven compatibility with Cisco Aironet infrastructure products through the Cisco Compatible Extensions Program Version 4) with Microsoft Windows Vista and XP only.
<b>Sub-channels</b>	Multinational support with frequency bands and channels compliant to local regulations.
<b>Media Access Protocol</b>	CSMA/CA (Collision Avoidance) with ACK
<b>Network Architecture Models</b>	Ad-hoc (Peer to Peer) Infrastructure (Access Point Required)
<b>Roaming</b>	IEEE 802.11 compliant roaming between 2.4GHz band Access Points
<b>Output Power (for CCK and OFDM)<sup>2</sup></b>	15 dBm typical
<b>Power Consumption</b>	Transmit: 1.4 Watts (average, with one spatial streams) Receive: 1.3 Watts (average with two receive chains) Idle mode <sup>3</sup> : 30 mW (average) Radio off: 20 mW (max)
<b>Power Management</b>	ACPI compliant power management 802.11 compliant power saving mode
<b>Receiver Sensitivity<sup>4</sup></b>	54 Mbps: -74 dBm, 6 Mbps: -91 dBm
<b>Antenna Connections</b>	2 U.FL type connectors, 50 ohm nominal impedance
<b>Form Factor</b>	PCI-Express Half-MiniCard
<b>Weight</b>	0.0075 lb (3.4 g)
<b>Dimensions</b>	0.12 x 1.06 x 1.18 in (3.1 x 26.8 x 30.0 mm)
<b>Operating Voltage</b>	3.3V +/- 9%
<b>Temperature</b>	Operating 32° to 176° F (0° to 80° C) Non-operating -40° to 176° F (-40° to 80° C)
<b>Humidity</b>	Operating 10% to 90% (non-condensing) Non-operating 5% to 90% (non-condensing)



## Technical Specifications

<b>Altitude</b>	Operating	0 to 10,000 ft (3,048 m)
	Non-operating	0 to 50,000 ft (15,240 m)
<b>Configuration Utility<sup>5</sup></b>	Microsoft Windows XP	
	Choice of Configuration Utility:	
		<ul style="list-style-type: none"> <li>• Microsoft Windows XP Wireless Network Connection Manager</li> <li>• Intel PROSet for Microsoft Windows XP (required for Cisco Compatible Extensions support)</li> </ul>
	Microsoft Windows Vista	
		<ul style="list-style-type: none"> <li>• Microsoft Windows Vista Wireless Network Connection Manager.</li> <li>• Intel IHV extensions for Windows Vista available to support Cisco Compatible Extensions.</li> </ul>
<b>LED Activity</b>	LED Off – Radio OFF; Solid LED On – Radio ON	
		<ol style="list-style-type: none"> <li>1. Check latest software/driver release for updates on supported security features.</li> <li>2. Maximum output power may vary by country according to local regulations.</li> <li>3. In Power Save Polling mode and on battery power.</li> <li>4. Receiver sensitivity is measured at a packet error rate of 8% for 802.11b (CCK modulation) and a packet error rate of 10% for 802.11a/g (OFDM modulation).</li> <li>5. WLAN supplier's client utility is required for Cisco Compatible Extensions support with Microsoft Windows XP. WLAN may also be compatible with certain third-party software supplicants. WLAN supplier IHV extensions required for Cisco Compatible Extensions support for Microsoft Windows Vista.</li> </ol>

---

<b>Broadcom 4322AGN 802.11a/b/g/n WiFi Adapter</b>	<b>Wireless LAN Standards</b>	IEEE 802.11a IEEE 802.11b IEEE 802.11g IEEE 802.11n
	<b>Interoperability</b>	Wi-Fi certified (802.11abg only) Cisco Compatible Extensions Program compliant (802.11abg only) with Microsoft Windows Vista and XP
	<b>Frequency Band</b>	2.4 GHz and 5 GHz
	<b>Data Rates</b>	802.11b: 1, 2, 5.5, 11 Mbps 802.11a/g: 6, 9, 12, 18, 24, 36, 48, 54 Mbps 802.11n: 6, 6.5, 9, 12, 13, 13.5, 18, 19.5, 24, 26, 27, 36, 39, 40.5, 48, 52, 54, 58.5, 65, 78, 81, 104, 108, 117, 121.5, 130, 135, 162, 216, 243, 270, 300 Mbps
	<b>Frequency Support</b>	20 MHz: 2.4 GHz and 5 GHz bands 40 MHz: 2.4 GHz and 5 GHz bands
	<b>Modulation</b>	Direct Sequence Spread Spectrum DBPSK, DQPSK, CCK, OFDM, BPSK, QPSK, 16-QAM, 64-QAM
	<b>Security<sup>1</sup></b>	Supports 64- and 128-bit WEP, WPA, WPA2, hardware-accelerated AES, 802.1x authentication types EAP-TLS, EAP-TTLS, PEAP-GTC, PEAP-MSCHAPv2, LEAP, EAP-FAST.
		Support for Cisco Security Features (proven compatibility with Cisco Aironet infrastructure products through the Cisco Compatible Extensions Program Version 4) with Microsoft Windows Vista and XP only.



## Technical Specifications

<b>Sub-channels</b>	Multinational support with frequency bands and channels compliant to local regulations.
<b>Media Access Protocol</b>	CSMA/CA (Collision Avoidance) with ACK
<b>Network Architecture Models</b>	Ad-hoc (Peer to Peer) Infrastructure (Access Point Required)
<b>Roaming</b>	IEEE 802.11 compliant roaming between access points
<b>Output Power (for CCK)<sup>2</sup></b>	17 dBm
<b>Output Power (for OFDM; power varies by data rate)<sup>2</sup></b>	15 dBm
<b>Power Consumption</b>	Idle associated: 250 mW Idle unassociated: 150 mW Transmit/Receive 20 MHz channel: 2.0 W (max) Transmit/Receive 40 MHz channel: 2.0 W (max)
<b>Power Management</b>	ACPI compliant power management 802.11 compliant power saving mode
<b>Receiver Sensitivity<sup>3</sup></b>	270 Mbps: -61dBm, , 54 Mbps: -72 dBm, 11 Mbps: -85 dBm , 1 Mbps: -92 dBm
<b>Antenna type</b>	High efficiency dual band antenna with spatial diversity, mounted in the display enclosure
<b>Form Factor</b>	PCI-Express Half-MiniCard
<b>Weight</b>	0.013 lb (6 g)
<b>Dimensions</b>	0.19 x 1.06 x 1.18 in (4.75 x 26.8 x 30 mm)
<b>Operating Voltage</b>	3.3v +/- 10%
<b>Temperature</b>	Operating 14° to 149° F (-10° to 65° C) Non-operating -40° to 176° F (-40° to 80° C)
<b>Humidity</b>	Operating 10% to 90% (non-condensing) Non-operating 5% to 95% (non-condensing)
<b>Altitude</b>	Operating 0 to 10,000 ft (3,048 m) Non-operating 0 to 50,000 ft (15,240 m)
<b>Configuration Utility<sup>4</sup></b>	Microsoft Windows XP Choice of Configuration Utility: <ul style="list-style-type: none"><li>● Microsoft Windows XP Wireless Network Connection Manager</li><li>● Broadcom Wireless Configuration Utility (required for Cisco Compatible Extensions support)</li></ul> Microsoft Windows Vista <ul style="list-style-type: none"><li>● Microsoft Windows Vista Wireless Network Connection Manager</li><li>● Broadcom IHV extensions for Windows Vista available to support Cisco Compatible Extensions.</li></ul>
<b>LED Activity</b>	LED Off – Radio OFF; Solid LED On – Radio ON <ol style="list-style-type: none"><li>1. Check latest software/driver release for updates on supported security features.</li><li>2. Maximum output power may vary by country according to local regulations.</li><li>3. Receiver sensitivity is measured at a packet error rate of 8% for 802.11b (CCK modulation) and a packet error rate of 10% for 802.11a/g (OFDM modulation).</li><li>4. WLAN supplier's client utility is required for Cisco Compatible Extensions support with Microsoft</li></ol>



## Technical Specifications

Windows XP. WLAN may also be compatible with certain third-party software supplicants. WLAN supplier IHV extensions required for Cisco Compatible Extensions support for Microsoft Windows Vista.

HP Integrated Module with Bluetooth 2.1+EDR Wireless Technology	Bluetooth Specification	2.1+EDR Compliant
	Dimensions	1.18 x 0.26 x 0.13 in (30 x 6.5 x 3.25 mm)
	Frequency Band	2402 to 2480 MHz
	Number of Available Channels	79 (1 MHz) available channels
	Data Rates and Throughput	3 Mbps data rate; throughput up to 2.17 Mbps Synchronous Connection Oriented links up to 3, 64 kbps, voice channels Asynchronous Connection Less links 2178.1 kbps/177.1 kbps asymmetric or 1306.9 kbps symmetric
	Transmit Power	-6 dBm to 4 dBm (Bluetooth Class II)
	Receiver Sensitivity	Better than -80 dBm at 0.1 % raw bit error rate
	Power Consumption	Peak (Tx) 264 mW Peak (Rx) 231 mW Sleep <1 mW
	Antenna	Internally integrated within module
	Range	Up 33 ft (10 m)
	Electrical Interface	USB 2.0 compliant Microsoft Windows Plug and Play compliant
	Bluetooth Software Supported	Broadcom Bluetooth for Windows Microsoft Windows Bluetooth Software
	Link Topology	Point to Point, Multipoint Pico Nets up to 7 slaves
	Security	Full support of Bluetooth Security Provisions
	Power Management	Microsoft Windows ACPI, and USB Bus Support Self configurable to optimize power conservation in all operating modes, including Standby, Hold, Park, and Sniff
	Certifications	All necessary regulatory approvals for supported countries, including: FCC (47 CFR) Part 15C, Section 15.247 & 15.249 ETS 300 328, ETS 300 826 Low Voltage Directive IEC950 UL, CSA, and CE Mark
	Temperature	Operating -4° to 158° F (-20° to 70° C) Non-operating -40° to 176° F (-40° to 80° C)
	Humidity	Operating 10% to 90% Non-operating 5% to 95%
	Altitude	Operating 15,000 ft (4,572 m) Non-operating 40,000 ft (12,192 m)
	Bluetooth Profiles Supported	Serial Port Profile (SPP) <sup>1</sup> Service Discovery Application Profile (SDAP)





## Technical Specifications

Dial-Up Networking (DUN)<sup>1,2</sup>  
 Generic Object Exchange Profile (GOEP)<sup>1,2</sup>  
 Object Push Profile (OPP)<sup>1,2</sup>  
 File Transfer Profile (FTP)  
 Synchronization Profile (SYNC)  
 Hard Copy Cable Replacement (HCRP)<sup>1,2</sup>  
 Personal Area Networking Profile (PAN)<sup>1,2</sup>  
 Human Interface Device Profile (HID)<sup>1,2,3</sup>  
 FAX Profile (FAX)  
 Basic Imaging Profile (BIP)<sup>2</sup>  
 Headset Profile (HSP)  
 Hands Free Profile (HFP)  
 Advanced Audio Distribution Profile (A2DP)

<sup>1</sup> indicates the profile is supported by Microsoft Windows XP SP2

<sup>2</sup> indicates the profile is part of Windows Vista

### Environmental Data

#### Eco-Label Certifications

This product has received or is in the process of being certified to the following approvals and may be labeled with one or more of these marks:

- US Energy Star
- IT ECO declaration
- EPEAT – Gold where HP registers commercial notebook products. See <http://www.epeat.net> for registration status in your country.

#### System Configuration

The configuration used for the Energy Consumption and Declared Noise Emissions data for the Convertible Mini tower Desktop model is based on a "Typically Configured Notebook"

#### HP ProBook 6450b Notebook PC

Energy Consumption	115 VAC	230 VAC	100 VAC
Normal Operation	13.37W	13.50W	13.20W
Sleep (Energy Star low power mode)	1.05W	1.11W	1.01W
Off	0.49W	0.52W	0.45W
Heat Dissipation*	115 VAC	230 VAC	100 VAC
Normal Operation	46 BTU/hr	46 BTU/hr	45 BTU/hr
Sleep	4 BTU/hr	4 BTU/hr	3 BTU/hr
Off	2 BTU/hr	2 BTU/hr	2 BTU/hr

\* Heat dissipation is calculated based on the measured watts, assuming the service level is attained for one hour.



## Technical Specifications

### Declared Noise Emissions (in accordance with ISO 7779 and ISO 9296)

System Fan Off	Sound Power (LWAd, bels)	Sound Pressure (LpAm, decibels)
Idle	2.6	17.3
Fixed Disk (random writes)	2.7	17.6

System fan is usually off except when charging the battery

### HP ProBook 6550b Notebook PC

Energy Consumption	115 VAC	230 VAC	100 VAC
Normal Operation	9.33W	9.65W	9.26W
Sleep (Energy Star low power mode)	0.8W	0.95W	0.79W
Off	0.64W	0.82W	0.64W

Heat Dissipation*	115 VAC	230 VAC	100 VAC
Normal Operation	32 BTU/hr	33 BTU/hr	32 BTU/hr
Sleep	3 BTU/hr	3 BTU/hr	3 BTU/hr
Off	2 BTU/hr	3 BTU/hr	2 BTU/hr

\* Heat dissipation is calculated based on the measured watts, assuming the service level is attained for one hour.

### Declared Noise Emissions (in accordance with ISO 7779 and ISO 9296)

System Fan Off	Sound Power (LWAd, bels)	Sound Pressure (LpAm, decibels)
Idle	3.0	22.5
Fixed Disk (random writes)	3.0	22.6

System fan is usually off except when charging the battery

### HP ProBook 6450b Notebook PC and HP 6550b Notebook PC

**Batteries** This battery(s) in this product comply with EU Directive 2006/66/EC

Batteries used in the product do not contain:

- Mercury greater the 5ppm by weight
- Cadmium greater than 10ppm by weight

The battery type and chemistry used in the product is:

Li-ion  
High capacity Lithium-Ion battery

### Additional information

This product is in compliance with the Restrictions of Hazardous Substances (RoHS) directive – 2002/95/EC.



## Technical Specifications

This HP product is designed to comply with the Waste Electrical and Electronic Equipment (WEEE) Directive - 2002/96/EC.

This product is in compliance with California Proposition 65 (State of California; Safe Drinking Water and Toxic Enforcement Act of 1986).

This product is in compliance with the IEEE 1680 (EPEAT) standard at the Gold level, see [www.epeat.net](http://www.epeat.net)

Plastics parts weighing over 25 grams used in the product are marked per ISO 11469 and ISO1043.

This product contains 0% post consumer recycled plastic (by wt.)

This product is greater than 95.1% recycle-able when properly disposed of at end of life.

### Packaging Materials

- External:
  - Corrugated carton – 360 g
  - Cardboard & misc. – 365 g
- Internal:
  - Polyethylene low density – 15 g
  - EPE - Expanded Polyethylene – 90 g
- The Corrugated carton packaging material is made from 70% – 80% recycled content.
- The Cardboard & misc. packaging material is made from 70% – 80% recycled content.
- The Polyethylene low density packaging material is made from 0% recycled content.
- The EPE –Expanded Polyethylene packaging material is made from 70% – 80% recycled content.

HP follows these guidelines to decrease the environmental impact of product packaging:

- Eliminate the use of heavy metals such as lead, chromium, mercury and cadmium in packaging materials.
- Eliminate the use of ozone-depleting substances (ODS) in packaging materials.
- Design packaging materials for ease of disassembly.
- Maximize the use of post-consumer recycled content materials in packaging materials.
- Use readily recyclable packaging materials such as paper and corrugated materials.
- Reduce size and weight of packages to improve transportation fuel efficiency.
- Plastic packaging materials are marked according to ISO 11469 and DIN 6120 standards.

### Material Usage

This product does not contain any of the following substances in excess of



## Technical Specifications

regulatory limits (for reference of these limits please refer to the HP General Specification of the Environment ([http://www.hp.com/hpinfo/globalcitizenship/environment/supplychain/gen\\_specifications.html](http://www.hp.com/hpinfo/globalcitizenship/environment/supplychain/gen_specifications.html)):

- Asbestos
- Certain Azo Colorants
- Certain Brominated Flame Retardants – may not be used as flame retardants in plastics
- Cadmium
- Chlorinated Hydrocarbons
- Chlorinated Paraffins
- Formaldehyde
- Halogenated Diphenyl Methanes
- Lead carbonates and sulfates
- Lead and Lead compounds
- Mercuric Oxide Batteries
- Ozone Depleting Substances
- Polybrominated Biphenyls (PBBs)
- Polybrominated Biphenyl Ethers (PBBEs)
- Polybrominated Biphenyl Oxides (PBBOs)
- Polychlorinated Biphenyl (PCB)
- Polychlorinated Terphenyls (PCT)
- Polyvinyl Chloride (PVC) - except for wires and cables, and certain retail packaging has been voluntarily removed from most applications.
- Radioactive Substances
- Tributyl Tin (TBT), Triphenyl Tin (TPT), Tributyl Tin Oxide (TBTO)
- Nickel finishes that release greater than 0.5  $\mu\text{grams}/\text{cm}^2/\text{week}$ , measured according to EN 1811:1998, are not used on any product surface designed to be frequently handled or touched by users.

### End-of-life Management and Recycling

Hewlett-Packard offers end-of-life HP product return and recycling programs in many geographic areas. To recycle your product, please go to: <http://www.hp.com/go/reuse-recycle> or contact your nearest HP sales office. Products returned to HP will be recycled, recovered or disposed of in a responsible manner.

The EU WEEE directive (2002/95/EC) requires manufacturers to provide treatment information for each product type for use by treatment facilities. This information (product disassembly instructions) is posted on the Hewlett Packard web site at: <http://www.hp.com/go/recyclers>. These instructions may be used by recyclers and other WEEE treatment facilities as well as HP OEM customers who integrate and re-sell HP equipment.

### Hewlett-Packard Corporate Environmental Information

For more information about HP's commitment to the environment: Global Citizenship Report  
<http://www.hp.com/hpinfo/globalcitizenship/gcreport/index.html>  
Environment website  
<http://www.hp.com/environment>  
Eco-label certifications  
<http://www.hp.com/hpinfo/globalcitizenship/environment/productdesign/ecolabels.html>  
ISO 14001 certificates:  
<http://www.hp.com/hpinfo/globalcitizenship/environment/operations/>



Copyright © 2011 Hewlett-Packard Development Company, L.P.

All rights reserved. Microsoft, Windows, Windows 7, Windows Vista and Windows XP are registered trademarks or trademarks of Microsoft Corporation in the U.S. and/or other countries. Intel, Core, and Celeron are registered trademarks or trademarks of Intel Corporation in the U.S. and/or other countries. Bluetooth is a registered trademark of Bluetooth SIG, Inc., in the U.S. and other countries. All other product names mentioned herein may be trademarks of their respective companies.

The information contained herein is subject to change without notice and is provided "as is" without warranty of any kind. The warranties for HP products are set forth in the express limited warranty statements accompanying such products. Nothing herein should be construed as constituting an additional warranty. HP shall not be liable for technical or editorial errors or omissions contained herein.

