



TECHNICAL GUIDE

R-410A SERIES 10 J**XP 6-1/2 Thru 12-1/2 TON 60 Hertz



6-1/2 THROUGH 10 TON



12-1/2 TON

Description

ASHRAE 90.1 COMPLIANT

Series 10 J**XP units are convertible single packages with a common footprint cabinet and common roof curb for all 6-1/2 through 12-1/2 ton models. All units have two compressors with independent refrigeration circuits to provide 2 stages of cooling. The units were designed for light commercial applications and can be easily installed on a roof curb, slab, or frame.

All J**XP units are self-contained and assembled on rigid full perimeter base rails allowing for 3-way forklift access and overhead rigging. Every unit is completely charged, wired, piped, and tested at the factory to provide a quick and easy field installation.

All units are convertible between side and down airflow. Independent economizer designs are used on side and down discharge applications, as well as all tonnage sizes.

J**XP units are available in the following configurations: heat pump and heat pump with electric heaters. Electric heaters are available as factory-installed options or field-installed accessories.

Tested in accordance with:

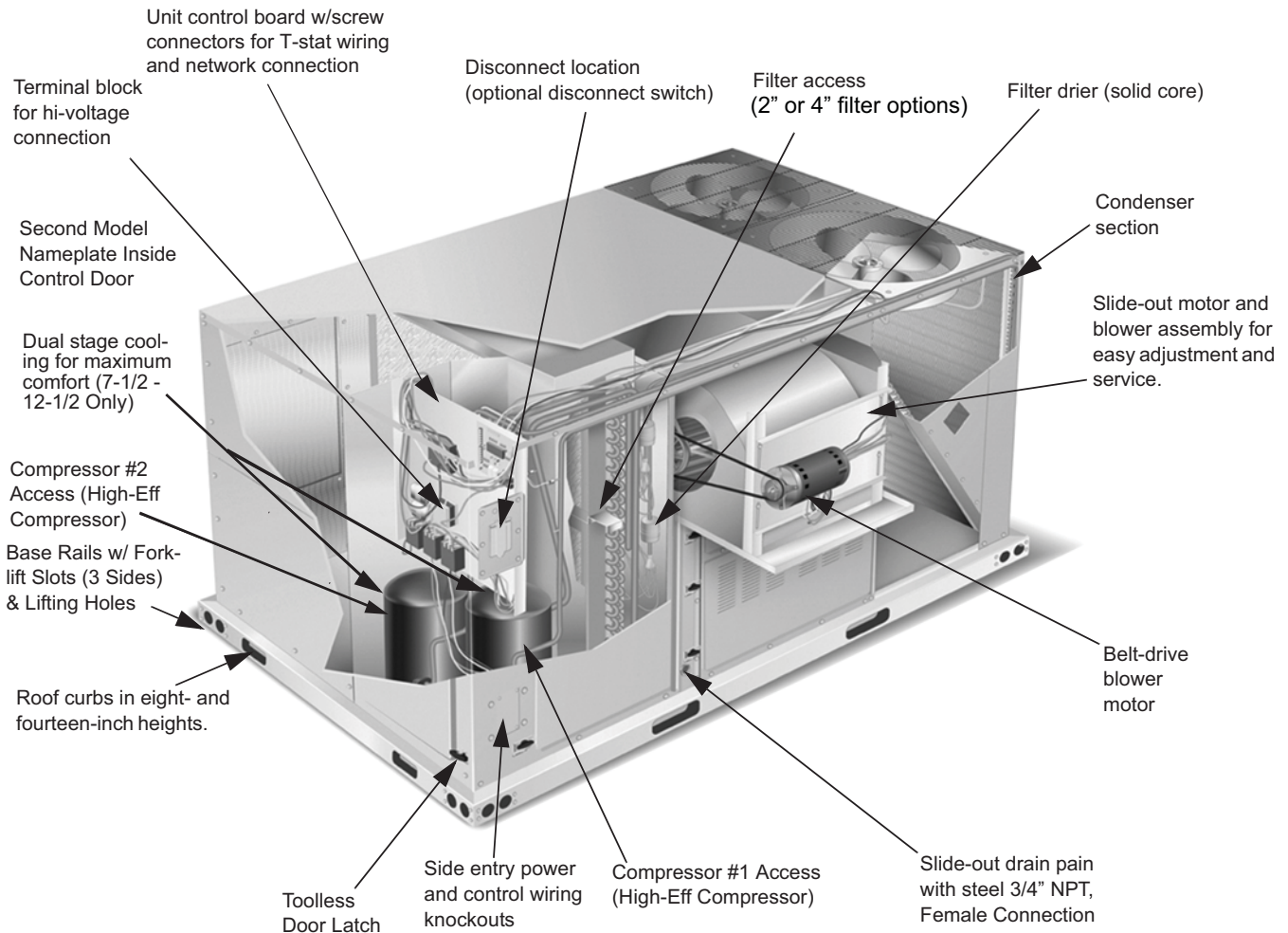

Table of Contents

Description	1
Table of Contents	2
Component Location	2
Nomenclature	3
Features and Benefits	4
Guide Specifications	9
Physical Data	12
Capacity Performance	14
Airflow Performance	26
Sound Performance	33
Electrical Data	35
Typical Wiring Diagrams	43
Weights and Dimensions	45
Economizer Options	52

Component Location

Heat Pump



Nomenclature

6.5-12.5 Ton Series 10 Model Number Nomenclature

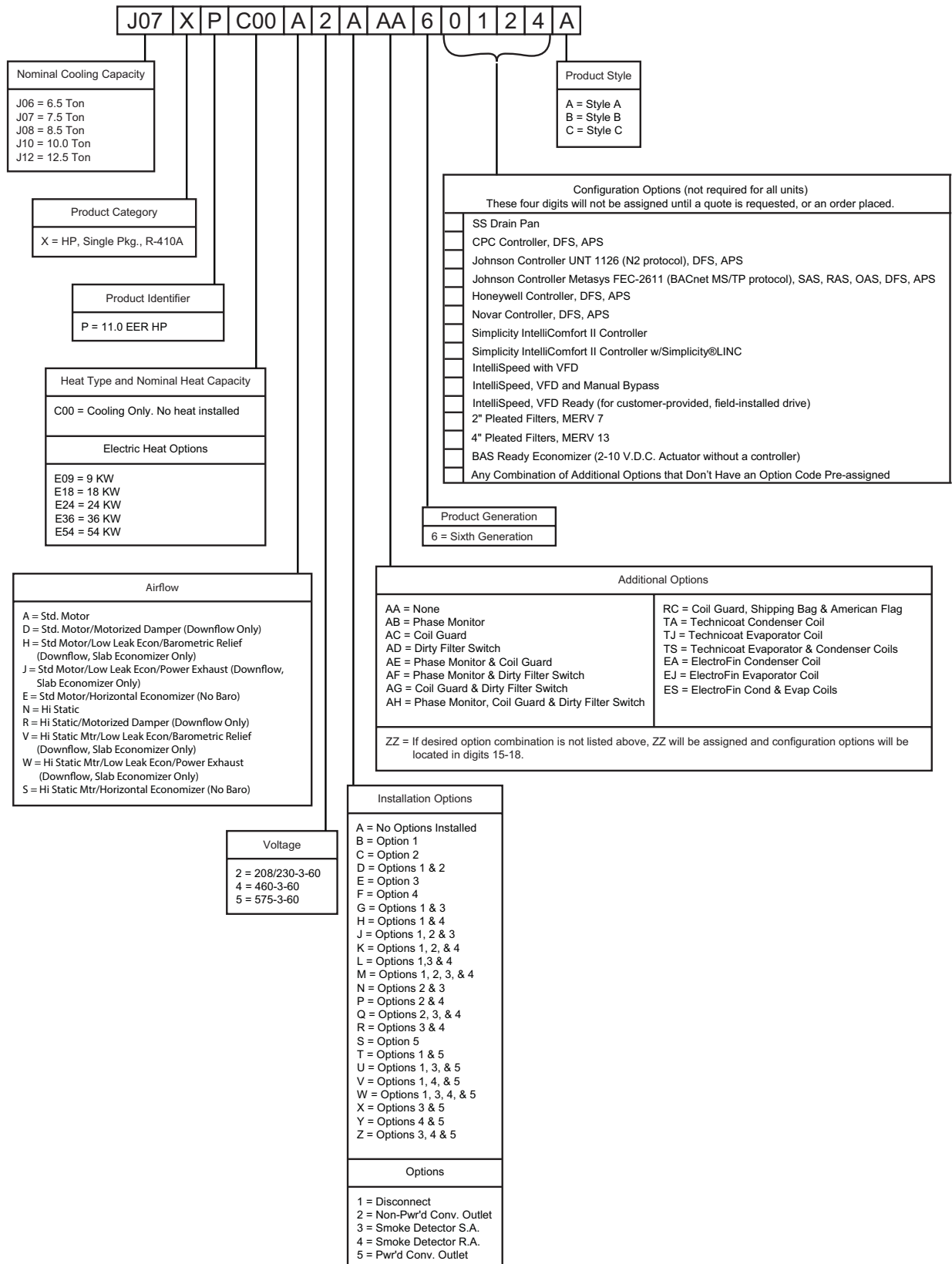

Features and Benefits

Standard Features

- **High Efficiency** – High efficiency units reach as high as 11.5 EER. These efficiencies exceed all legislated minimum levels and provide low operating costs.
- **Service Friendly** – The J**XP incorporates a number of enhancements which improve serviceability.

The motor and blower slide out of the unit as a common assembly. This facilitates greater access to all the indoor airflow components, thus simplifying maintenance and adjustment.

Service time is reduced through the use of hinged, toolless panels. Such panels provide access to frequently inspected components and areas, including the control box, compressors, filters, indoor motor & blower, and the heating section. The panels are screwed in place at the factory to prevent access by children or other unauthorized persons. It is recommended that the panels be secured with screws once service is complete.

Service windows have been placed in both condenser section walls. Rotation of the cover allows easy access to the condenser coils for cleaning or inspection.

The unit control board utilizes flash codes to aid in diagnosis of unit malfunctions. Unique alarm codes quickly identify the source of the unit alarm.

All units use the same standard filter size. This standardization removes any confusion on which filter sizes are needed for replacement.

The non-corrosive drain pan slides out of the unit to permit easy cleaning. The drain pan is accessed by removing the drain pan cover plate on the rear of the unit. Once the plate is removed, the drain pan slides out through the rear of the unit.

All J**XP units have a second model nameplate located inside the control access door. This is to prevent deterioration of the nameplate through weathering.
- **Environmentally Aware** – For improved Indoor Air Quality, A combination of foil faced and elastometric rubber insulation is used exclusively throughout the units.
- **Convertible Airflow Design** – The side duct openings are covered when they leave the factory. If a side supply/return is desired, the installer simply removes the two side duct covers from the outside of the unit and installs them over the down shot openings. No panel cutting is required. Convertible airflow design allows maximum field flexibility and minimum inventory.
- **System Protection** - Suction line freezestats are supplied on all units to protect against loss of charge and coil frosting when the economizer operates at low outdoor air temperatures while the compressors are running. Every unit has solid-core liquid line filter-driers and high and low-pressure switches. Internal compressor protection is standard on all compressors. Crankcase heaters are standard on reciprocating compressors. Scroll compressors do not require crankcase heaters. Phase Monitors are standard on units with scroll compressors. This accessory monitors the incoming power to the unit and protects the unit from phase loss and reversed phase rotation.

- **Advanced Controls** - Simplicity® control boards have standardized a number of features previously available only as options or by utilizing additional controls.
- **Low Ambient** - An integrated low-ambient control allows all units to operate in the cooling mode down to 0°F outdoor ambient without additional assistance. Optionally, the control board can be programmed to lockout the compressors when the outdoor air temperature is low or when free cooling is available.

CAUTION

The Simplicity® control board used in this product will effectively operate the cooling system down to 0°F when this product is applied in a comfort cooling application for people. An economizer is typically included in this type of application. When applying this product for process cooling applications (computer rooms, switchgear, etc.), please reference applications bulletin AE-011-07 or call the applications department for Unitary Products @ 1-877-UPG-SERV for guidance. Additional accessories may be needed for stable operation at temperatures below 30° F.

- **Anti-Short Cycle Protection** - To aid compressor life, an anti-short cycle delay is incorporated into the standard controls. Compressor reliability is further ensured by programmable minimum run times. For testing, the anti-short cycle delay can be temporarily overridden with the push of a button.
- **Fan Delays** - Fan on and fan off delays are fully programmable. Furthermore, the heating and cooling fan delay times are independent of one another. All units are programmed with default values based upon their configuration of cooling and heat.
- **Safety Monitoring** - The control board monitors the high and low-pressure switches, the freezestats, the gas valve, if applicable, and the temperature limit switch on gas and electric heat units. The unit control board will alarm on ignition failures, compressor lockouts and repeated limit switch trips.
- **Nuisance Trip Protection and Strikes** - To prevent nuisance trouble calls, the control board uses a “three times, you’re out” philosophy. The high and low-pressure switches and the freezestats must trip three times within two hours before the unit control board will lock out the associated compressor.
- **On Board Diagnostics** - Each alarm will energize a trouble light on the thermostat, if so equipped, and flash an alarm code on the control board LED. Each high and low-pressure switch alarm as well as each freezestat alarm has its own flash code. The control board saves the five most recent alarms in memory, and these alarms can be reviewed at any time. Alarms and programmed values are retained through the loss of power.
- **Reliable** – From the beginning – All units undergo computer automated testing before they leave the factory.

Units are tested for refrigerant charge and pressure, unit amperage, and 100% functionality. For the long term – All J**XP units are painted with a long lasting, powder paint that stands up over the life of the unit. The paint used has been proven by a 1000 hour salt spray test.

- **Flexible Placement** – All models and configurations share the same cabinet/footprint and thus the same roof curb. You have the flexibility to set one curb and choose the correct tonnage size and heating option after the internal loads have been determined.

To further simplify planning and installation, Predator® XP cabinets are designed to fit your roof. With the optional roof curb, the unit ductwork is designed to fit around 24" on-center joists or between 48" on-center joists.

The drain pan can be rotated to drain to either the front or the rear of the unit. Additionally, the drain pan can be fitted to drain through the roof curb. As it is sometimes difficult to have a level installation, the drain pan features a generous slope to ensure proper drainage.

- **Full Perimeter Base Rails** – The permanently attached base rails provide a solid foundation for the entire unit and protect the unit during shipment. The rails offer forklift access from 3 sides, and rigging holes are available so that an overhead crane can be used to place the units on a roof.
- **Easy Installation** – Electric utility knockouts are supplied in the unit underside as well as the side of the unit. A clearly identified location is provided to mount a field supplied electrical disconnect switch. Utility connections can be made quickly and with a minimum amount of field labor. All units are shipped with 2" throw-away filters installed.
- **Wide Range of Indoor Airflows** – All indoor fan motors are belt-drive type providing maximum flexibility to handle most airflow requirements. For high static applications, factory installed alternate indoor fan motors are available. With the optional indoor fan motor, all units can supply nominal airflow at a minimum of 1.5" ESP.
- **Warranty** - All models include a 1-year limited warranty on the complete unit. Compressors and electric heater elements each carry a 5-year warranty.

Factory Installed Options

Johnson Controls offers several equipment options factory installed, for the J**XP line.

- **Optional Factory Installed Economizers** - Predator units offer a variety of optional factory installed economizers with low leak dampers. The outdoor air enthalpy sensor enables economizer operation if the outdoor enthalpy is less than the setpoint of the economizer logic module. See economizer options section to determine the correct economizer for your application.
- **Downflow Slab Economizers (with barometric relief and fresh air hood)** - All units offer a variety of optional factory installed down flow economizers that are shipped, installed and wired with low leak dampers designed to meet ASHRAE 90.1-2010, AMCA 511 Class 1A damper, and the International Energy Conservation Code (IECC) certification requirements by achieving leakage rates of 3 cfm/sq. ft. at 1" of static pressure. Each economizer goes through a rigorous 60,000 cycle test. Dry bulb, single enthalpy, and dual

enthalpy (with field installed kit) can be selected. The economizer has spring return, fully modulating damper actuators and is capable of introducing up to 100% outdoor air. As the outdoor air intake dampers open, the return air dampers close. The changeover from mechanical refrigeration to economizer operation is regulated by the outdoor air dry bulb temperature or the outdoor air enthalpy input. The dual enthalpy kit provides a second input used to monitor the return air (field installed). The installer needs only to assemble the outdoor air hood, attach the enthalpy control the hood and mount the hood to the unit (Hood and control are provided). When selected with **BAS Ready Economizer Option** the actuator requires 2-10 VDC input from an external source, such as a field-installed or factory-installed BAS controller. BAS-ready actuators have an adjustable auxiliary end-switch for optional power exhaust control.

- **Horizontal Economizer - (Without barometric relief)** - All features of the downflow economizer exist except economizer is not designed with low leak dampers and you must order the duct mount barometric relief separately. **You must order a 1EH0408 if you are installing a power exhaust. You can order a 1RD0411 Barometric Relief for horizontal flow economizers only.**
- **Power Exhaust (Downflow only)** - This accessory installs in the unit with a down flow economizer.
- **Motorized Outdoor Air Damper** - The motorized outdoor air damper includes a slide-in/plug-in damper assembly with an outdoor air hood and filters. The outdoor air dampers open to the preset position when the indoor fan motor is energized. The damper has a range of 0% to 100% outdoor air entry. Factory installed option or field installed accessory.
- **Alternate Indoor Blower Motor** - For applications with high static restrictions, units are offered with optional indoor motors that provide higher static output and/or higher airflow, depending upon the installer's needs.
- **Stainless Steel Drain Pan** - An optional rust-proof stainless steel drain pan is available to provide years of trouble-free operation in corrosive environments.
- **Electric Heaters** - The electric heaters range from 9kW to 54kW and are available in all the voltage options of the base units. All heaters are dual staged. All heaters are intended for single point power supply.
- **IntelliSpeed™ Supply Fan Control Option (ASHRAE 90.1 compliant, section 6.4.3.10)** - Units configured with the **IntelliSpeed™** Supply Fan Option will contain a VFD for variable volume supply fan operation. This option allows the supply fan RPM to vary based on the number of compressors or heating stages energized. The economizer's minimum position will also be configurable to vary based on the supply fan VFD frequency output.
- **Disconnect Switch** - For heat pump units with electric heat, a HACR breaker sized to the unit is provided. For heat pump units, a switch sized to the largest electric heat available for the particular unit is provided. Factory installed option only.

- **Convenience Outlet - (Non-Powered/Powered)** - This option locates a 120V single-phase GFCI outlet with cover, on the corner of the unit housing adjacent to the compressors. The "Non-powered" option requires the installer to provide the 120V single-phase power source and wiring. The "Powered" option is powered by a stepdown transformer in the unit. Factory installed option only.
- **Smoke Detectors** - The smoke detectors stop operation of the unit by interrupting power to the control board if smoke is detected within the air compartment. Available for both the supply and/or return air.

WARNING

Factory installed smoke detectors in the return air, may be subjected to freezing temperatures during "off" times due to outside air infiltration. These smoke detectors have an operational limit of -4 °F to 158°F. Smoke detectors installed in areas that could be outside those limitations will have to be moved to prevent having false alarms.

- **Filters** – 2" Pleated MERV 7 or 4" Pleated MERV 13 are available to meet LEED requirements. A 2" Throwaway is shipped as standard.
- **Phase Monitors** - Designed to prevent unit damage. The phase monitor will shut the unit down in an out-of phase condition. **(Standard on units with Scroll Compressors.)**
- **Coil Guard** - Customers can purchase a coil guard kit to protect the condenser coil from damage. Additionally, this kit stops animals and foreign objects from entering the space between the inner condenser coil and the main cabinet. This is not a hail guard kit.
- **Dirty Filter Switch** - This kit includes a differential pressure switch that energizes the fault light on the unit thermostat, indicating that there is an abnormally high pressure drop across the filters. Factory installed option or field installed accessory.
- **Technicoat Condenser Coils** - The condenser coils are coated with a phenolic coating for protection against corrosion due to harsh environments.
- **Technicoat Evaporator Coil** - The evaporator coils are coated with a phenolic coating for protection against corrosion due to harsh environments.
- **ElectroFin® E-coat Condenser Coils** - The condenser coils are coated with an epoxy polymer coating to protect against corrosion.
- **ElectroFin® E-coat Evaporator Coils** - The evaporator coils are coated with an epoxy polymer coating to protect against corrosion.

Control Options

- **BAS - Building Automation System Controls Simplicity® INTELLI-Comfort II™ Control** - The Simplicity® INTELLI-Comfort II™ control is factory installed. It includes a supply air sensor, a return air sensor, and an outside air sensor. There are provisions for a field installed dirty filter indicator switch, an air-proving switch, an Outside Air Humidity sensor, a Return Air Humidity sensor, an Inside IAQ sensor, and an Outside Air IAQ sensor. Construction mode

operation, 365-day real time clock with 7 day programming plus holiday scheduling is built-in. Two different modes of demand ventilation are achieved through the INTELLI-Comfort II™ using CO₂ sensors. It uses an inside CO₂ sensor to perform Demand Ventilation. It can also use an Outside CO₂ sensor to perform Differential Demand Ventilation. It uses a Patented Comfort Ventilation algorithm to provide comfortable ventilation air temperature. The patented economizer-loading algorithm will protect the equipment when harsh operating conditions exist. It uses the INTELLI-Start™ algorithm to maximize energy savings by recovering the building from the Unoccupied Setpoints to the Occupied Setpoints just in time for the Occupied Time Period to begin. The Simplicity® INTELLI-Comfort II™ balances space temperature, ventilation air temperature and CO₂.

- **Simplicity® INTELLI-Comfort II™ with Simplicity@LINC Control** - The Simplicity® INTELLI-Comfort II™ with Simplicity@LINC control is factory installed. It includes all the features of the INTELLI-Comfort II™ control with an additional control to translate communications from MODBUS to the BACnet MSTP protocol.
- **Novar® BAS Control** - The Novar® building automation system controller is factory installed. Includes supply air sensor, return air sensor, dirty filter indicator switch, and air proving switch.
- **Johnson Controls BAS Control** - The Johnson Control YK-UNT-1126 building automation system controller is factory installed. Includes supply air sensor, return air sensor, dirty filter indicator switch, and air proving switch.
- **Johnson Controls BACnet BAS Control** - The Johnson Controls FEC-2611 building automation system controller is factory installed. Includes supply air sensor, return air sensor, outdoor air sensor, dirty filter indicator switch, and air proving switch.
- **CPC BAS Control** - The Computer Process Controls Model 810-3060 ARTC Advanced Rooftop building automation system controller is factory installed. Includes supply air sensor, return air sensor, dirty filter indicator switch and air proving switch.
- **Honeywell BAS Control** - The Honeywell W7750C building automation system controller is factory installed. Includes air supply sensor, return air sensor, dirty filter indicator switch, and air proving switch.

Field Installed Accessories

Johnson Controls offers several equipment accessories for field installation, for the J**XP line.

- **Downflow Slab Economizers (with fresh air hood and without barometric relief)** - All units offer a variety of optional factory installed down flow economizers that are shipped, installed and wired with low leak dampers designed to meet ASHRAE 90.1-2010, AMCA 511 Class 1A damper, and the International Energy Conservation Code (IECC) certification requirements by achieving leakage rates of 3 cfm/sq. ft. at 1" of static pressure. Each economizer goes through a rigorous 60,000 cycle test. Dry bulb, single enthalpy, and dual enthalpy (with field installed kit) can be selected. The economizer has spring return, fully modulating damper actuators and is capable of introducing up to 100%

outdoor air. As the outdoor air intake dampers open, the return air dampers close. The changeover from mechanical refrigeration to economizer operation is regulated by the outdoor air dry bulb temperature or the outdoor air enthalpy input. The dual enthalpy kit provides a second input used to monitor the return air (field installed). The installer needs only to assemble the outdoor air hood, attach the enthalpy control the hood and mount the hood to the unit (Hood and control are provided).

- **Horizontal Economizer - (Without barometric relief) -** All features of the downflow economizer exist except economizer is not designed with low leak dampers and you must order the duct mount barometric relief separately. **You must order a 1EH0408 if you are installing a power exhaust. You can order a 1RD0411 Barometric Relief for horizontal flow economizers only.**
- **Dual Enthalpy Control, Accessory** - This kit contains the required components to convert a single enthalpy economizer to dual enthalpy.
- **Barometric Relief Damper** - Zero to 100% capacity barometric relief dampers for use with horizontal flow, or field installed slab economizers.
- **Power Exhaust** - This accessory installs in the unit with a down flow economizer. Power exhaust plugs into the connector in the unit bulkhead. **You must purchase 1EH0408 barometric relief when applying to a horizontal flow application.**
- **Manual Outdoor Air Damper** - Like the motorized outdoor air damper, each manual outdoor air damper includes a slide-in damper assembly with an outdoor air hood and filters. Customers have a choice of dampers with ranges of 0% to 100% or 0% to 35% outdoor air entry.
- **Motorized Outdoor Air Damper** - The motorized outdoor air damper includes a slide-in/plug-in damper assembly with an outdoor air hood and filters. The outdoor air dampers open to the preset position when the indoor fan motor is energized. The damper has a range of 0% to 100% outdoor air entry. Factory installed option or field installed accessory.
- **Smoke Detectors** - The smoke detectors stop operation of the unit by interrupting power to the control board if smoke is detected within the air compartment.
- **CO₂ Sensor** - Senses CO₂ levels and automatically overrides the economizer when levels rise above the preset limits.
- **Dirty Filter Switch** - This kit includes a differential pressure switch that energizes the fault light on the unit thermostat, indicating that there is an abnormally high pressure drop across the filters.
- **Coil Guard** - Field installed decorative wire coil guard.
- **Hail Guard** - This kit includes a sloped hood which installs over the outside condenser coil and prevents damage to the coil fins from hail strikes. Field installed accessory only.
- **Electric Heaters** - The electric heaters range from 9 kW to 54kW and are available in all the voltage options of the base units. All heaters are dual staged. All units include an adapter panel for easy installation of the electric heaters. Necessary hardware and connectors are included with the heaters. All heaters are intended for single point power supply.
- **Low Limit / Compressor Lockout Kit**
 - **Compressor Lockout (CLO):** To prevent mechanical (compressorized) operation of the unit during cold outdoor conditions where there is a risk of returning liquid refrigerant back to the compressors.
 - **Low Limit Control (LLC):** To prevent the supply air from dropping below a specified setpoint by utilizing the units first stage heating means when there is a demand for cooling during cold outside conditions.
- **Metal Frame Filter Kit** - Metal frame with polyester filter medium.
- **Permanent Filters** - Permanent filters are available.
- **Roof Curbs** - The roof curbs have insulated decks and are shipped disassembled The roof curbs are available in 8" and 14" heights. For applications with security concerns, burglar bars are available for the duct openings of the roof curbs.
- **Burglar Bars** - Mount in the supply and return openings to prevent entry into the duct work.
- **Thermostat** - The units are designed to operate with 24-volt electronic and electro-mechanical thermostats. All units (with or without an economizer) operate with two-stage heat/two-stage cool or two-stage cooling only thermostats, depending upon unit configuration.

Accessories

Part Number	Description
1RC0470	Roof Curb, 8" Height
1RC0471	Roof Curb, 14" Height
1RC0472	Roof Curb, Transition (7.5 T through 12.5 T)
1BD0408	Burglar Bars, Downflow
2TP04520925	Electric Heat 9kW 230V
2TP04521825	Electric Heat 18kW 230V
2TP04522425	Electric Heat 24kW 230V
2TP04523625	Electric Heat 36kW 230V
2TP04525425	Electric Heat 54kW 230V
2TP04520946	Electric Heat 9kW 460V
2TP04521846	Electric Heat 18kW 460V
2TP04522446	Electric Heat 24kW 460V
2TP04523646	Electric Heat 36kW 460V
2TP04525446	Electric Heat 54kW 460V
2TP04520958	Electric Heat 9kW 575V
2TP04521858	Electric Heat 18kW 575V
2TP04522458	Electric Heat 24kW 575V
2TP04523658	Electric Heat 36kW 575V
2TP04525458	Electric Heat 54kW 575V
2TP04540925	Electric Heat 9kW 230V, 42" Tall Cabinet
2TP04541825	Electric Heat 18kW 230V, 42" Tall Cabinet
2TP04542425	Electric Heat 24kW 230V, 42" Tall Cabinet
2TP04543625	Electric Heat 36kW 230V, 42" Tall Cabinet
2TP04540946	Electric Heat 9kW 460V, 42" Tall Cabinet
2TP04541846	Electric Heat 18kW 460V, 42" Tall Cabinet
2TP04542446	Electric Heat 24kW 460V, 42" Tall Cabinet
2TP04543646	Electric Heat 36kW 460V, 42" Tall Cabinet
2TP04540958	Electric Heat 9kW 575V, 42" Tall Cabinet
2TP04541858	Electric Heat 18kW 575V, 42" Tall Cabinet
2TP04542458	Electric Heat 24kW 575V, 42" Tall Cabinet
2TP04543658	Electric Heat 36kW 575V, 42" Tall Cabinet
2MD04703224	Motorized Damper, Downflow without Barometric Relief
2MD04703224	Motorized Damper, Downflow without Barometric Relief
2MD04703724	Motorized Damper, Horizontal
2EE04708324	Downflow Economizer, Slab type for ERV & Downflow Applications, (no Barometric Relief or FA hood) 50" Cabinets
2EE04707524	Downflow Economizer, Slab type for ERV & Downflow Applications, (no Barometric Relief or FA hood) 42" Cabinets
2EE04706024	Horizontal Economizer without Barometric Relief
2PE04704706*	Power Exhaust 230V Downflow or Horizontal
2PE04704746*	Power Exhaust 460V Downflow or Horizontal
2PE04704758*	Power Exhaust 575V Downflow or Horizontal
2EC04700924	Dual Enthalpy Control (Use with Single Enthalpy Economizer)
1RD0411	Barometric Relief Kit, Ductmount for Horizontal Application (Incl. Damper & Hood)
1EH0408	Barometric Relief Kit for Power Exhaust, Horizontal Application
1FA0413	Manual Outside Air Damper 0-35%, Downflow
1FA0414	Manual Outside Air Damper 0-100%, Downflow
2AQ04700424	CO2 Detector Unit Mount
2AQ04700324	CO2 Detector Space Mount
2SD04700824	Smoke Detector for Supply (All Gen 5 units with 2" & 4" Filters)
2SD04700924	Smoke Detector for Return (All Gen 5 units with 2" & 4" Filters)
2SD04701024	Smoke Detector for Supply and Return (All Gen 5 units with 2" & 4" Filters)
2MK04700624	Low Limit / Compressor Lockout Kit
1CG0419	Coil Guard (Electric / Electric & HP models), 8-1/2 and 10 Ton
1CG0424	Coil Guard (Electric / Electric and HP models), 12-1/2 Ton
1CG0427	Coil Guard (Electric / Electric & HP Models), 6-1/2 and 7-1/2 Ton
1HG0411	Hail Guard Kit
1HG0415	Hail Guard Kit, 42" Tall Cabinet
1FL0402	Permanent Filter Kit
1FL0423	Permanent Filter Kit, 42" Tall Cabinet
2DF0401	Dirty Filter Switch
1FF0414	2" only Metal Filter Frame Kit, 50" Tall Cabinet
1FF0415	2" only Metal Filter Frame Kit, 42" Tall Cabinet

Guide Specifications

GENERAL

Units shall be manufactured by Johnson Controls in an ISO 9001 certified facility. Series 10, J**XP units are convertible single packages with a common footprint cabinet and common roof curb for all 6-1/2 through 12-1/2 ton models. All units have two compressors with independent R-410a refrigeration circuits to provide 2 stages of cooling. The units were designed for light commercial applications and can be easily installed on a roof curb, slab, or frame. All units are self-contained and assembled on rigid full perimeter base rails allowing for 3-way forklift access and overhead rigging. Every unit is completely charged with R-410a, wired, piped, and tested at the factory to provide a quick and easy field installation. All units are convertible between side and down airflow. Independent economizer designs are used on side and down discharge applications, as well as all tonnage sizes. All units are available in the following configurations: heat pump and heat pump with electric heat. Electric heaters are available as factory-installed options or field-installed accessories.

DESCRIPTION

Units shall be factory assembled, single package (Heat Pump), designed for outdoor installation. They shall have built in field convertible duct connections for down discharge supply/return or horizontal discharge supply/return and be available with factory installed options or field installed accessories. The units shall be factory wired, piped and charged with R-410a refrigerant and factory tested prior to shipment. All unit wiring shall be both numbered and color coded. The cooling performance shall be rated in accordance with DOE and AHRI test procedures. Units shall be CSA certified to ANSI Z21.47 and UL 1995/CAN/CSA No. 236-M90 standards.

UNIT CABINET

Unit cabinet shall be constructed of galvanized steel with exterior surfaces coated with a non-chalking, powder paint finish, certified at 1000 hour salt spray test per ASTM-B117 standards. Indoor blower sections shall be insulated with up to 1" thick insulation coated on the airside. Either aluminum foil faced or elastometric rubber insulation shall be used in the unit's compartments and be fastened to prevent insulation from entering the air stream. Cabinet doors shall be hinged with toolless access for easy servicing and maintenance. Full perimeter base rails shall be provided to assure reliable transit of equipment, overhead rigging, fork truck access and proper sealing on roof curb applications. Disposable 2" filters shall be furnished and be accessible through hinged access door. Fan performance measuring ports shall be provided on the outside of the cabinet to allow accurate air measurements of evaporator fan performance without removing panels or creating bypass of the coils. Condensate pan shall be slide out design, constructed of a non corrosive material, internally sloped and conforming to ASHRAE 62-B9 standards. Condensate connection shall be a minimum of 3/4" I.D. female and be rigid mount connection.

INDOOR (EVAPORATOR) FAN ASSEMBLY

Fan shall be a belt drive assembly and include an adjustable pitch motor pulley. Job site selected brake horsepower shall not exceed the motors nameplate horsepower rating plus the service factor. Units shall be designed to operate within the service factor. Fan wheel shall be double inlet type with forward curve blades, dynamically balanced to operate smoothly throughout the entire range of operation. Airflow design shall be constant volume. Bearings shall be sealed and permanently lubricated for longer life and no maintenance. Entire blower assembly and motor shall be slide out design.

OUTDOOR (CONDENSER) FAN ASSEMBLY

The outdoor fans shall be of the direct drive type, discharge air vertically, have aluminum blades riveted to corrosion resistant steel spider brackets and shall be dynamically balanced for smooth operation. The outdoor fan motors shall have permanently lubricated bearings internally protected against overload conditions and staged independently. A cleaning window shall be provided on two sides of the units for coil cleaning.

REFRIGERANT COMPONENTS

Compressors:

- a. Shall be fully hermetic type, direct drive, internally protected with internal high-pressure relief and over temperature protection. The hermetic motor shall be suction gas cooled and have a voltage range of + or – 10% of the unit nameplate voltage.
- b. Shall have internal spring isolation and sound muffling to minimize vibration and noise, and be externally isolated on a dedicated, independent mounting.

Coils:

- a. Evaporator and condenser coils shall have aluminum plate fins mechanically bonded to seamless internally enhanced copper tubes with all joints brazed. Special Phenolic coating shall be available as a factory option.
- b. Evaporator and condenser coils shall be of the direct expansion, draw-thru design.

Refrigerant Circuit and Refrigerant Safety Components shall include:

- a. Independent fixed-orifice or thermally operated expansion devices.
- b. Solid core filter drier/strainer to eliminate any moisture or foreign matter.
- c. Accessible service gage connections on both suction and discharge lines to charge, evacuate, and measure refrigerant pressure during any necessary servicing or troubleshooting, without losing charge.
- d. The unit shall have two independent refrigerant circuits, equally split in 50% capacity increments.

Unit Controls:

- a. Unit shall be complete with self-contained low-voltage control circuit protected by a resettable circuit breaker on the 24-volt transformer side.
- b. Unit shall incorporate a lockout circuit which provides reset capability at the space thermostat or base unit should any of the following standard safety devices trip and shut off compressor:
 - c. Loss-of-charge/Low-pressure switch.
 - High-pressure switch.
 - Freeze-protection thermostat, evaporator coil. If any of the above safety devices trip, an LED (light-emitting diode) indicator shall flash a diagnostic code that indicates which safety switch has tripped.
 - d. Unit shall incorporate "AUTO RESET" compressor over temperature, over current protection.
 - e. Unit shall operate with conventional thermostat designs and have a low voltage terminal strip for easy hook-up.
 - f. Unit control board shall have on-board diagnostics and fault code display.
 - g. Standard controls shall include anti-short cycle and low voltage protection, and permit cooling operation down to 0 °F.
 - h. Control board shall monitor each refrigerant safety switch independently.
 - i. Control board shall retain last 5 fault codes in non-volatile memory, which will not be lost in the event of a power loss.

ELECTRIC HEATING SECTION (IF EQUIPPED)

An electric heating section, with nickel chromium elements, shall be provided in a range of 9 thru 54 KW, offering two states of capacity all sizes. The heating section shall have a primary limit control(s) (automatic reset) to prevent the heating element system from operating at an excessive temperature. The Heating Section assembly shall slide out of the unit for easy maintenance and service. Units with Electric Heating Sections shall be wired for a single point power supply with branch circuit fusing (where required).

UNIT OPERATING CHARACTERISTICS

Unit shall be capable of starting and running at 125 °F outdoor temperature, exceeding maximum load criteria of AHRI Standard 340/360. The compressor, with standard controls, shall be capable of operation down to 0 °F outdoor temperature.

ELECTRICAL REQUIREMENTS - All unit power wiring shall enter unit cabinet at a single factory provided location and be capable of side or bottom entry to minimize roof penetrations and avoid unit field modifications. Separate side and bottom openings shall be provided for the control wiring.

STANDARD LIMITED WARRANTIES - Compressor – 5 Years, Elect. Heat Elem. – 5 Years, Parts – 1 Year

FACTORY INSTALLED OPTIONAL OUTDOOR AIR (Shall be made available by either/or):

- **ELECTRONIC ENTHALPY AUTOMATIC ECONOMIZER** - Outdoor and return air dampers that are interlocked and positioned by a fully-modulating, spring-return damper actuator. The maximum leakage rate for the outdoor air intake dampers shall be designed to meet ASHRAE 90.1-2010, AMCA 511 Class 1A damper, and the International Energy Conservation Code (IECC) certification requirements by achieving leakage rates of 3 cfm/sq. ft. at 1" of static pressure. During economizer operation, a mixed-air temperature control shall modulate the outdoor and return air damper assembly to prevent the supply air temperature from dropping below 55°F. Changeover from compressor to economizer operation shall be provided by an integral electronic enthalpy control that feeds input into the basic module. The outdoor intake opening shall be covered with a rain hood that matches the exterior of the unit. Water eliminator/filters shall be provided. Simultaneous economizer/compressor operation is also possible. Dampers shall fully close on power loss. Available with barometric relief and power exhaust.
- **MOTORIZED OUTDOOR AIR DAMPERS** - Outdoor and return air dampers that are interlocked and positioned by a 2- position, spring-return damper actuator. A unit-mounted potentiometer shall be provided to adjust the outdoor and return air damper assembly to take in the design CFM of outdoor air to meet the ventilation requirements of the conditioned space during normal operation. Whenever the indoor fan motor is energized, the dampers open up to one of two pre-selected positions - regardless of the outdoor air enthalpy. Dampers return to the fully closed position when the indoor fan motor is de-energized. Dampers shall fully close on power loss.

ADDITIONAL FACTORY INSTALLED OPTIONS

- **ALTERNATE INDOOR BLOWER MOTOR** – For applications with high restrictions, units are available with optional indoor blower motors that provide higher static output and/or higher airflow.
- **CONVENIENCE OUTLET (POWERED/NON-POWERED)**– Unit can be provided with an optional 120VAC GFCI outlet with cover on the corner of the unit housing the compressors.
- **ELECTRIC HEAT** - Electric Heaters range from 9 kW to 54 kW and are available in all the voltage options of the base unit.
- **PHASE MONITOR** - Designed to prevent damage in out-of-phase condition.
- **COIL GUARD** - Designed to prevent condenser coil damage.
- **DIRTY FILTER SWITCH** – This kit includes a differential pressure switch that energizes the fault light on the unit thermostat, indicating that there is an abnormally high-pressure drop across the filters.
- **BREAKER** – An HACR breaker can be factory installed on heat pumps or heat pumps with electric heat.

- **DISCONNECT SWITCH** - A disconnect can be factory installed on a cooling only units sized for the largest electric heat available.
- **SMOKE DETECTOR** – A smoke detector can be factory mounted and wired in the supply and/or return air compartments.
- **CONTROLS**
 - **Johnson Light Commercial System (LCCS)** - Provides rooftop system integration for LCCS single zone, change-over bypass and VAV systems. (Not offered on J**ZR units)
 - **Johnson UNT 1126 Rooftop Controller** - N2 protocol with air proving and dirty filter sensors. Hardware contains generic application logic; field engineering and/or modification may be required.

OTHER PRE-ENGINEERED ACCESSORIES AVAILABLE

- **ROOF CURB** - 14" and 8" high, full perimeter knockdown curb, with hinged design for quick assembly.
- **BAROMETRIC RELIEF DAMPER** – (Unit mounted – Downflow, Duct Mounted – Horizontal) – Contains a rain hood, air inlet screen, exhaust damper and mounting hardware. Used to relieve internal air pressure through the unit during economizer operation.
- **ECONOMIZER** (Downflow and Horizontal flow)
- **POWER EXHAUST** – (Unit mount – Downflow, Duct mount – Horizontal flow)
- **DUAL ENTHALPY KIT** - Provides a second input to economizer to monitor return air.

Physical Data

J06 thru 12XP Physical Data

Component	Models				
	J06XP	J07XP	J08XP	J10XP	J12XP
Nominal Tonnage	6.5	7.5	8.5	10	12.5
AHRI COOLING PERFORMANCE					
Gross Capacity @ AHRI A point (Mbh)	80000	92550	105600	122000	158300
AHRI net capacity (Mbh)	78000	90000	102000	117000	150000
EER	11.5	11.2	11.2	11.2	11.0
IEER	12.0	12.0	11.4	11.4	10.5
IPLV	12.4	12.4	12.4	12.4	11.9
Nominal CFM	2600	3000	3750	3750	4900
System power (KW)	6.78	8.18	9.27	10.45	13.64
Refrigerant type	R-410A	R-410A	R-410A	R-410A	R-410A
Refrigerant charge (lb-oz)					
System 1	14-2	13-0	13-12	12-14	17-6
System 2	12-10	13-2	13-13	12-12	17-8
AHRI HEATING PERFORMANCE					
47°F capacity rating (Mbh)	75.0	88.0	90.5	102.0	135.0
System power (KW) / COP	6.2 / 3.35	7.7 / 3.35	7.9 / 3.35	8.6 / 3.30	13.2 / 3.0
17°F capacity rating (Mbh)	43.0	51.0	53.0	58.0	90.0
System power (KW) / COP	5.7 / 2.20	6.4 / 2.25	6.9 / 2.25	7.8 / 2.20	13.5 / 2.2
HSPF (Btu/Watts-hr)	-	-	-	-	-
DIMENSIONS (inches)					
Length	89	89	89	89	119-7/16
Width	59	59	59	59	59
Height	50-3/4	50-3/4	50-3/4	50-3/4	50-3/4
OPERATING WT. (lbs.)	1080	1090	1137	1135	1403
COMPRESSORS					
Type	Scroll	Scroll	Scroll	Scroll	Scroll
Quantity	2	2	2	2	2
Unit Capacity Steps (%)	50 / 100	50 / 100	50 / 100	50 / 100	50/100
CONDENSER COIL DATA					
Face area (Sq. Ft.)	29.0	29.0	29.0	29.0	47.5
Rows	2	2	2	2	2
Fins per inch	16	16	16	16	15
Tube diameter (in.)	3/8	3/8	3/8	3/8	3/8
Circuitry Type	Split-face	Split-face	Split-face	Split-face	Split-face
Refrigerant control	TXV	29.0	29.0	TXV	TXV
EVAPORATOR COIL DATA					
Face area (Sq. Ft.)	13.2	13.2	13.2	13.2	13.2
Rows	4	4	4	4	4
Fins per inch	15	15	15	15	15
Tube diameter	3/8	3/8	3/8	3/8	3/8
Circuitry Type	Split-face	Split-face	Split-face	Split-face	Split-face
Refrigerant control	TXV	TXV	TXV	TXV	TXV

J06 thru 12XP Physical Data (Continued)

Component	Models									
	J06XP		J07XP		J08XP		J10XP		J12XP	
Nominal Tonnage	6.5		7.5		8.5		10		12.5	
CONDENSER FAN DATA										
Quantity of Fans	2		2		2		2		4	
Fan diameter (Inch)	24		24		24		24		24	
Type	Prop		Prop		Prop		Prop		Prop	
Drive Type	Direct		Direct		Direct		Direct		Direct	
Quantity of motors	2		2		2		2		4	
Motor HP each	1/3		1/3		1/3		1/3		1/3	
No. speeds	1		1		1		1		1	
RPM	850		850		850		850		850	
Nominal total CFM	6800		6800		6800		6800		14000	
BELT DRIVE EVAP FAN DATA										
Quantity	1		1		1		1		1	
Fan Size (Inch)	15 x 15		15 x 15		15 x 15		15 x 15		15 x 15	
Type	Centrifugal		Centrifugal		Centrifugal		Centrifugal		Centrifugal	
Motor Sheave	VL40	VL44	1VL40	1VM50	1VP50	1VP50	1VM50	1VM50	1VM50	1VP56
Blower Sheave	AK84	AK71	AK69	AK69	AK89	AK74	AK84	AK74	AK74	BK77
Belt	A54	A52	A52	A54	A56	A54	A56	A54	A54	BX56
Motor HP each	1-1/2	2	1-1/2	3	2	3	2	3	3	5
RPM	1725	1725	1725	1725	1725	1725	1725	1725	1725	1725
Frame size	56	56	56	56	56	56	56	56	56	184T
FILTERS										
Quantity - Size	4 - (24 x 20 x 2) ^{1,2}		4 - (24 x 20 x 2) ^{1,2}		4 - (24 x 20 x 2) ^{1,2}		4 - (24 x 20 x 2) ^{1,2}		4 - (24 x 20 x 2) ^{1,2}	
	4 - (24 x 20 x 2) ³		4 - (24 x 20 x 4) ³		4 - (24 x 20 x 4) ³		4 - (24 x 20 x 2) ³		4 - (24 x 20 x 4) ³	

1. 2 In. Throwaway, Standard, MERV (Minimum Efficiency Reporting Value) 3.
2. 2 In. Pleated, Optional, MERV 7.
3. 4 In. Pleated, Optional, MERV 13.

J06 thru 12XP Unit Limitations

Size (Tons)	Model	Unit Voltage	Unit Limitations		
			Applied Voltage		Outdoor DB Temp
			Min	Max	Max (°F)
J06 (6.5)	XP	208/230-3-60	187	252	125
		460-3-60	432	504	125
		575-3-60	540	630	125
J07 (7.5)	XP	208/230-3-60	187	252	125
		460-3-60	432	504	125
		575-3-60	540	630	125
J08 (8.5)	XP	208/230-3-60	187	252	125
		460-3-60	432	504	125
		575-3-60	540	630	125
J10 (10)	XP	208/230-3-60	187	252	125
		460-3-60	432	504	125
		575-3-60	540	630	125
J12 (12.5)	XP	208/230-3-60	187	252	125
		460-3-60	432	504	125
		575-3-60	540	630	125

Capacity Performance

J06 thru 12XP Cooling Capacities

J06XP (6.5 Ton)

Air on Evaporator Coil		Temperature of Air on Condenser Coil																	
CFM	WB (°F)	Total Capacity ¹ (MBh)	Total Input (kW) ²	Sensible Capacity (MBh)						Total Capacity ¹ (MBh)	Total Input (kW) ²	Sensible Capacity (MBh)							
				Return Dry Bulb (°F)								Return Dry Bulb (°F)							
				90	85	80	75	70	65			90	85	80	75	70	65		
				75°F						85°F									
1625	77	107.3	4.8	47.0	38.9	30.7	-	-	-	103.2	5.5	45.6	37.7	29.7	-	-	-		
	72	99.2	4.7	57.9	49.8	41.7	33.5	-	-	94.7	5.4	56.2	48.3	40.4	32.5	-	-		
	67	91.1	4.7	68.8	60.7	52.6	44.5	36.4	-	86.3	5.4	66.8	58.9	51.0	43.1	35.2	-		
	62	81.6	4.6	81.6	70.5	61.8	53.7	45.5	37.4	78.4	5.3	78.4	70.8	61.1	53.2	45.3	37.4		
1950	77	112.8	4.8	53.0	43.7	34.4	-	-	-	107.7	5.5	51.3	42.1	32.9	-	-	-		
	72	104.3	4.8	65.2	55.9	46.6	37.3	-	-	98.9	5.5	63.0	53.8	44.6	35.5	-	-		
	67	95.7	4.7	77.4	68.1	58.8	49.5	40.2	-	90.1	5.4	74.7	65.6	56.4	47.2	38.0	-		
	62	85.8	4.7	85.8	78.4	69.1	59.8	50.5	41.2	81.8	5.4	81.8	76.8	67.6	58.4	49.2	40.0		
	57	83.3	4.6	83.3	81.9	72.6	63.3	54.0	44.7	80.0	5.4	80.0	79.0	69.8	60.6	51.4	42.3		
2275	77	118.3	4.9	58.9	48.5	38.0	-	-	-	112.3	5.5	56.9	46.5	36.0	-	-	-		
	72	109.4	4.8	72.5	62.0	51.5	41.1	-	-	103.1	5.5	69.8	59.4	48.9	38.5	-	-		
	67	100.4	4.8	86.0	75.5	65.1	54.6	44.1	-	93.9	5.5	82.7	72.2	61.8	51.3	40.9	-		
	62	90.0	4.7	90.0	86.3	76.5	66.0	55.6	45.1	85.2	5.4	85.2	82.7	74.0	63.6	53.1	42.7		
	57	87.4	4.7	87.4	86.7	80.3	69.8	59.4	48.9	83.4	5.4	83.4	82.9	76.5	66.0	55.6	45.1		
2600	77	123.8	4.9	64.9	53.3	41.6	-	-	-	116.8	5.6	62.6	50.9	39.2	-	-	-		
	72	114.4	4.9	79.7	68.1	56.5	44.8	-	-	107.2	5.5	76.6	64.9	53.2	41.5	-	-		
	67	105.1	4.8	94.5	82.9	71.3	59.7	48.0	-	97.6	5.5	90.6	78.9	67.2	55.5	43.7	-		
	62	94.2	4.8	94.2	94.2	83.8	72.2	60.6	48.9	88.7	5.4	88.7	88.7	80.5	68.8	57.1	45.3		
	57	91.5	4.7	91.5	91.5	88.0	76.4	64.7	53.1	86.7	5.4	86.7	86.7	83.2	71.4	59.7	48.0		
2925	72	117.9	4.9	85.1	72.4	59.7	47.0	-	-	109.4	5.5	82.4	69.5	56.6	43.8	-	-		
	67	108.2	4.8	102.9	88.1	75.4	62.6	49.9	-	99.6	5.5	96.1	84.4	71.5	58.7	45.8	-		
	62	97.1	4.8	97.1	97.1	90.5	77.8	65.1	52.4	90.5	5.4	90.5	90.5	85.7	72.9	60.0	47.1		
	57	94.2	4.7	94.2	94.2	92.5	79.8	67.1	54.3	88.5	5.4	88.5	88.5	86.7	73.8	61.0	48.1		
3250	72	121.3	4.9	90.6	76.7	62.9	49.1	-	-	111.6	5.5	88.1	74.1	60.1	46.1	-	-		
	67	111.3	4.9	111.3	93.3	79.5	65.6	51.8	-	101.6	5.5	101.6	89.9	75.9	61.9	47.9	-		
	62	99.9	4.8	99.9	99.9	97.3	83.5	69.6	55.8	92.3	5.4	92.3	92.3	91.0	77.0	62.9	48.9		
	57	97.0	4.8	97.0	97.0	97.0	83.2	69.4	55.6	90.2	5.4	90.2	90.2	90.2	76.2	62.2	48.2		
				95°F						105°F									
1625	77	99.2	6.2	44.1	36.5	28.8	-	-	-	92.8	7.0	39.9	33.2	25.5	-	-	-		
	72	90.3	6.1	54.5	46.8	39.1	31.4	-	-	84.1	7.0	51.2	43.5	35.8	28.1	-	-		
	67	81.5	6.1	64.8	57.1	49.4	41.7	34.0	-	75.4	7.0	62.6	53.9	46.2	38.5	30.8	-		
	62	75.1	6.1	75.1	71.1	60.4	52.7	45.0	37.3	69.4	6.9	69.4	67.0	55.6	47.9	40.2	32.5		
1950	77	102.7	6.2	49.6	40.5	31.4	-	-	-	95.7	7.0	46.0	37.0	28.0	-	-	-		
	72	93.5	6.2	60.8	51.7	42.7	33.6	-	-	86.8	7.0	57.3	48.3	39.3	30.3	-	-		
	67	84.4	6.1	72.1	63.0	53.9	44.9	35.8	-	77.8	7.0	68.7	59.7	50.7	41.7	32.7	-		
	62	77.8	6.1	77.8	75.1	66.0	57.0	47.9	38.8	71.6	6.9	71.6	70.0	61.0	52.0	43.0	34.0		
	57	76.7	6.1	76.7	76.1	67.0	57.9	48.9	39.8	71.9	6.9	71.9	70.8	61.8	52.8	43.8	34.8		
2275	77	106.2	6.2	55.0	44.5	34.1	-	-	-	98.7	7.0	52.1	40.8	30.5	-	-	-		
	72	96.8	6.2	67.2	56.7	46.3	35.8	-	-	89.4	7.0	63.4	53.1	42.8	32.5	-	-		
	67	87.3	6.1	79.4	68.9	58.5	48.1	37.6	-	80.2	7.0	74.8	65.5	55.2	44.9	34.6	-		
	62	80.4	6.1	80.4	79.1	71.6	61.2	50.7	40.3	73.8	6.9	73.8	73.0	66.4	56.1	45.8	35.5		
	57	79.3	6.1	79.3	79.0	72.7	62.2	51.8	41.3	74.1	6.9	74.1	73.5	67.3	57.0	46.7	36.4		
2600	77	109.8	6.2	60.4	48.6	36.7	-	-	-	101.6	7.0	58.2	44.6	33.0	-	-	-		
	72	100.0	6.2	73.5	61.7	49.9	38.1	-	-	92.1	7.0	69.5	57.9	46.3	34.7	-	-		
	67	90.2	6.1	86.7	74.9	63.1	51.2	39.4	-	82.6	7.0	80.8	71.3	59.7	48.1	36.5	-		
	62	83.1	6.1	83.1	83.1	77.2	65.4	53.6	41.8	76.0	6.9	76.0	76.0	71.8	60.2	48.6	37.0		
	57	82.0	6.1	82.0	82.0	78.4	66.5	54.7	42.9	76.3	6.9	76.3	76.3	72.8	61.2	49.6	38.0		
2925	72	100.9	6.1	79.6	66.6	53.6	40.6	-	-	92.9	7.0	75.7	62.8	49.8	36.9	-	-		
	67	91.1	6.1	89.3	80.7	67.7	54.7	41.7	-	83.3	6.9	82.4	76.3	64.2	51.3	38.3	-		
	62	83.9	6.1	83.9	83.9	80.9	67.9	54.9	41.9	76.6	6.9	76.6	76.6	74.6	61.6	48.7	35.7		
	57	82.7	6.1	82.7	82.7	80.9	67.9	54.9	41.9	77.0	6.9	77.0	77.0	75.2	62.3	49.3	36.3		
3250	72	101.9	6.1	85.7	71.4	57.2	43.0	-	-	93.7	6.9	81.9	67.6	53.3	39.0	-	-		
	67	91.9	6.1	91.9	86.5	72.3	58.1	43.9	-	84.0	6.9	84.0	81.4	68.7	54.4	40.1	-		
	62	84.7	6.0	84.7	84.7	84.7	70.5	56.2	42.0	77.3	6.9	77.3	77.3	77.3	63.0	48.7	34.4		
	57	83.5	6.0	83.5	83.5	83.5	69.3	55.1	40.8	77.7	6.9	77.7	77.7	77.7	63.3	49.0	34.7		

J06XP (6.5 Ton) (Continued)

Air on Evaporator Coil		Temperature of Air on Condenser Coil															
CFM	WB (°F)	Total Capacity ¹ (MBh)	Total Input (kW) ²	Sensible Capacity (MBh)						Total Capacity ¹ (MBh)	Total Input (kW) ²	Sensible Capacity (MBh)					
				Return Dry Bulb (°F)								Return Dry Bulb (°F)					
				90	85	80	75	70	65			90	85	80	75	70	65
				115°F						125°F							
1625	77	86.5	7.8	35.6	29.9	22.2	-	-	-	80.1	8.7	30.4	26.7	19.0	-	-	-
	72	77.9	7.8	48.0	40.3	32.6	24.9	-	-	71.7	8.6	44.8	37.1	29.4	21.7	-	-
	67	69.4	7.8	60.5	50.7	43.0	35.3	27.6	-	63.3	8.6	58.3	47.5	39.8	32.1	24.4	-
	62	63.7	7.8	63.7	62.9	50.7	43.0	35.3	27.6	58.0	8.6	58.0	58.0	45.8	38.1	30.4	22.7
1950	77	88.8	7.8	42.4	33.5	24.6	-	-	-	81.8	8.7	38.8	30.0	21.1	-	-	-
	72	80.0	7.8	53.8	44.9	36.0	27.1	-	-	73.2	8.6	50.4	41.5	32.6	23.8	-	-
	67	71.2	7.8	65.3	56.4	47.4	38.5	29.6	-	64.6	8.6	61.9	53.0	44.2	35.3	26.5	-
	62	65.4	7.8	65.4	64.9	55.9	47.0	38.1	29.2	59.2	8.6	59.2	59.2	50.9	42.0	33.2	24.3
	57	67.1	7.7	67.1	65.5	56.5	47.6	38.7	29.8	62.4	8.5	62.4	60.2	51.3	42.5	33.6	24.7
2275	77	91.1	7.8	49.3	37.0	26.9	-	-	-	83.5	8.6	47.3	33.3	23.2	-	-	-
	72	82.1	7.8	59.7	49.5	39.4	29.2	-	-	74.7	8.6	55.9	45.9	35.9	25.9	-	-
	67	73.1	7.8	70.1	62.0	51.9	41.7	31.6	-	65.9	8.6	65.5	58.6	48.6	38.6	28.6	-
	62	67.1	7.8	67.1	66.8	61.2	51.0	40.9	30.7	60.4	8.6	60.4	60.4	56.0	46.0	36.0	26.0
	57	68.9	7.7	68.9	68.1	61.9	51.7	41.5	31.4	63.7	8.5	63.7	62.6	56.5	46.4	36.4	26.4
2600	77	93.4	7.8	56.1	40.5	29.2	-	-	-	85.2	8.6	55.7	36.5	25.4	-	-	-
	72	84.2	7.8	65.5	54.1	42.8	31.4	-	-	76.2	8.6	61.5	50.3	39.2	28.0	-	-
	67	74.9	7.8	74.9	67.7	56.3	45.0	33.6	-	67.3	8.6	67.3	64.1	53.0	41.8	30.7	-
	62	68.8	7.8	68.8	68.8	66.5	55.1	43.7	32.3	61.6	8.6	61.6	61.6	61.1	49.9	38.8	27.6
	57	70.6	7.7	70.6	70.6	67.2	55.8	44.4	33.0	65.0	8.5	65.0	65.0	61.6	50.4	39.3	28.1
2925	72	84.9	7.8	71.9	59.0	46.1	33.2	-	-	76.8	8.6	68.0	55.2	42.4	29.5	-	-
	67	75.6	7.8	75.6	72.0	60.7	47.8	35.0	-	67.8	8.6	67.8	67.6	57.3	44.4	31.6	-
	62	69.4	7.8	69.4	69.4	68.2	55.3	42.4	29.5	62.1	8.6	62.1	62.1	61.8	49.0	36.2	23.3
	57	71.2	7.7	71.2	71.2	69.5	56.6	43.7	30.8	65.5	8.5	65.5	65.5	63.8	51.0	38.1	25.3
3250	72	85.6	7.8	78.2	63.8	49.4	35.0	-	-	77.4	8.6	74.5	60.0	45.5	31.0	-	-
	67	76.2	7.8	76.2	76.2	65.1	50.7	36.3	-	68.3	8.6	68.3	68.3	61.5	47.0	32.5	-
	62	69.9	7.8	69.9	69.9	69.9	55.5	41.1	26.7	62.6	8.6	62.6	62.6	62.6	48.1	33.6	19.1
	57	71.8	7.7	71.8	71.8	71.8	57.4	43.0	28.6	66.0	8.5	66.0	66.0	66.0	51.5	37.0	22.5

1. These capacities are gross ratings. For net capacity, deduct air blower motor, MBh = 3.415 x kW. Refer to the appropriate Blower Performance Table for the kW of the supply air blower motor.
2. These ratings include the condenser fan motors (total 1 kW) and the compressor motors but not the supply air blower motor.

J07XP (7.5 Ton)

Air on Evaporator Coil		Temperature of Air on Condenser Coil															
CFM	WB (°F)	Total Capacity ¹ (MBh)	Total Input (kW) ²	Sensible Capacity (MBh)						Total Capacity ¹ (MBh)	Total Input (kW) ²	Sensible Capacity (MBh)					
				Return Dry Bulb (°F)								Return Dry Bulb (°F)					
				90	85	80	75	70	65			90	85	80	75	70	65
				75°F						85°F							
1875	77	116.6	5.8	48.6	40.0	31.5	-	-	-	110.0	6.5	45.8	37.4	29.0	-	-	-
	72	107.8	5.7	62.9	54.3	45.7	37.2	-	-	101.4	6.5	59.8	51.4	43.0	34.6	-	-
	67	99.0	5.6	77.2	68.6	60.0	51.5	42.9	-	92.8	6.4	73.8	65.4	57.0	48.6	40.2	-
	62	93.7	5.5	93.7	85.2	74.6	66.1	57.5	48.9	86.4	6.3	86.4	82.1	70.6	62.2	53.8	45.4
2250	77	120.7	5.8	53.8	44.0	34.1	-	-	-	113.5	6.5	50.7	41.1	31.5	-	-	-
	72	111.7	5.7	69.3	59.5	49.6	39.8	-	-	104.7	6.5	65.9	56.3	46.7	37.1	-	-
	67	102.6	5.6	84.8	75.0	65.1	55.3	45.5	-	95.8	6.4	81.2	71.5	61.9	52.3	42.7	-
	62	97.0	5.6	97.0	91.3	81.0	71.2	61.4	51.5	89.2	6.3	89.2	86.3	76.7	67.1	57.5	47.9
2625	77	124.9	5.8	59.0	47.9	36.8	-	-	-	117.1	6.6	55.6	44.8	34.0	-	-	-
	72	115.5	5.7	75.7	64.6	53.5	42.5	-	-	108.0	6.5	72.1	61.2	50.4	39.6	-	-
	67	106.1	5.6	92.4	81.3	70.2	59.2	48.1	-	98.8	6.4	88.5	77.7	66.8	56.0	45.2	-
	62	100.3	5.6	100.3	97.5	87.3	76.3	65.2	54.1	92.0	6.4	92.0	90.5	82.8	72.0	61.1	50.3
3000	77	129.1	5.8	64.1	51.8	39.5	-	-	-	120.7	6.6	60.5	48.5	36.5	-	-	-
	72	119.4	5.7	82.1	69.7	57.4	45.1	-	-	111.2	6.5	78.2	66.1	54.1	42.1	-	-
	67	109.6	5.6	100.0	87.7	75.4	63.0	50.7	-	101.8	6.4	95.8	83.8	71.7	59.7	47.7	-
	62	103.7	5.6	103.7	103.7	93.7	81.4	69.1	56.7	94.8	6.4	94.8	94.8	88.8	76.8	64.8	52.7
3375	77	129.1	5.8	64.1	51.8	39.5	-	-	-	120.7	6.6	60.5	48.5	36.5	-	-	-
	72	119.4	5.7	82.1	69.7	57.4	45.1	-	-	111.2	6.5	78.2	66.1	54.1	42.1	-	-
	67	109.6	5.6	100.0	87.7	75.4	63.0	50.7	-	101.8	6.4	95.8	83.8	71.7	59.7	47.7	-
	62	103.7	5.6	103.7	103.7	93.7	81.4	69.1	56.7	94.8	6.4	94.8	94.8	88.8	76.8	64.8	52.7
3750	77	129.1	5.8	64.1	51.8	39.5	-	-	-	120.7	6.6	60.5	48.5	36.5	-	-	-
	72	119.4	5.7	82.1	69.7	57.4	45.1	-	-	111.2	6.5	78.2	66.1	54.1	42.1	-	-
	67	109.6	5.6	100.0	87.7	75.4	63.0	50.7	-	101.8	6.4	95.8	83.8	71.7	59.7	47.7	-
	62	103.7	5.6	103.7	103.7	93.7	81.4	69.1	56.7	94.8	6.4	94.8	94.8	88.8	76.8	64.8	52.7
1875	77	103.4	7.3	43.0	34.8	26.5	-	-	-	95.4	8.2	37.5	31.2	23.2	-	-	-
	72	95.0	7.2	56.8	48.5	40.3	32.0	-	-	87.7	8.1	53.1	45.1	37.0	29.0	-	-
	67	86.6	7.2	70.5	62.3	54.0	45.8	37.5	-	79.9	8.1	68.7	58.9	50.9	42.9	34.8	-
	62	79.0	7.1	79.0	79.0	66.6	58.4	50.1	41.9	74.0	8.0	74.0	74.0	62.0	54.0	45.9	37.9
2250	77	106.3	7.3	47.7	38.2	28.8	-	-	-	97.6	8.2	43.7	34.5	25.3	-	-	-
	72	97.7	7.3	62.6	53.2	43.8	34.4	-	-	89.7	8.2	58.8	49.6	40.4	31.2	-	-
	67	89.0	7.2	77.6	68.1	58.7	49.3	39.9	-	81.8	8.1	73.9	64.7	55.5	46.3	37.1	-
	62	81.3	7.1	81.3	81.3	72.4	63.0	53.6	44.2	75.7	8.0	75.7	75.7	67.6	58.4	49.2	40.0
2625	77	109.3	7.4	52.3	41.7	31.1	-	-	-	99.9	8.3	49.8	37.7	27.4	-	-	-
	72	100.4	7.3	68.4	57.9	47.3	36.7	-	-	91.8	8.2	64.5	54.1	43.8	33.4	-	-
	67	91.5	7.2	84.6	74.0	63.4	52.8	42.2	-	83.7	8.1	79.2	70.5	60.2	49.8	39.4	-
	62	83.6	7.1	83.6	83.6	78.2	67.6	57.0	46.5	77.5	8.1	77.5	77.5	73.3	62.9	52.5	42.2
3000	77	112.2	7.4	56.9	45.2	33.4	-	-	-	102.1	8.3	56.0	41.0	29.5	-	-	-
	72	103.1	7.3	74.3	62.5	50.8	39.0	-	-	93.8	8.2	70.2	58.7	47.1	35.6	-	-
	67	94.0	7.2	91.6	79.9	68.1	56.3	44.6	-	85.6	8.1	84.4	76.3	64.8	53.3	41.7	-
	62	85.8	7.2	85.8	85.8	84.0	72.2	60.5	48.7	79.2	8.1	79.2	79.2	78.9	67.4	55.8	44.3
3375	77	103.5	7.3	79.7	67.0	54.2	41.4	-	-	93.9	8.2	75.2	62.7	50.2	37.7	-	-
	72	94.4	7.3	93.2	85.5	72.7	59.9	47.2	-	85.6	8.2	85.1	80.1	69.0	56.5	44.1	-
	67	86.2	7.2	86.2	86.2	85.3	72.5	59.7	47.0	79.3	8.1	79.3	79.3	79.1	66.7	54.2	41.7
	62	86.0	7.2	86.0	86.0	86.5	73.8	61.0	48.2	78.9	8.1	78.9	78.9	79.8	67.3	54.8	42.3
3750	77	104.0	7.3	85.2	71.4	57.6	43.8	-	-	94.0	8.3	80.1	66.7	53.3	39.8	-	-
	72	94.8	7.3	94.8	91.1	77.3	63.5	49.7	-	85.7	8.2	85.7	83.9	73.2	59.8	46.4	-
	67	86.5	7.2	86.5	86.5	86.5	72.8	59.0	45.2	79.4	8.1	79.4	79.4	79.4	65.9	52.5	39.1
	62	86.3	7.2	86.3	86.3	86.3	72.5	58.7	45.0	79.0	8.1	79.0	79.0	79.0	65.6	52.1	38.7

J07XP (7.5 Ton) (Continued)

Air on Evaporator Coil		Temperature of Air on Condenser Coil															
CFM	WB (°F)	Total Capacity ¹ (MBh)	Total Input (kW) ²	Sensible Capacity (MBh)						Total Capacity ¹ (MBh)	Total Input (kW) ²	Sensible Capacity (MBh)					
				Return Dry Bulb (°F)								Return Dry Bulb (°F)					
				90	85	80	75	70	65			90	85	80	75	70	65
				115°F						125°F							
1875	77	87.4	9.1	32.0	27.6	19.8	-	-	-	79.5	10.1	25.8	23.8	16.5	-	-	-
	72	80.3	9.1	49.4	41.6	33.8	26.0	-	-	73.0	10.0	45.8	38.2	30.6	23.0	-	-
	67	73.3	9.0	66.9	55.6	47.8	40.0	32.2	-	66.6	9.9	65.4	52.3	44.7	37.1	29.5	-
	62	68.9	8.9	68.9	68.9	57.4	49.6	41.7	33.9	63.9	9.9	63.9	63.9	52.7	45.1	37.5	29.9
2250	77	89.0	9.2	39.7	30.7	21.7	-	-	-	80.3	10.1	35.7	26.9	18.1	-	-	-
	72	81.7	9.1	55.0	46.0	37.0	28.1	-	-	73.8	10.0	51.2	42.4	33.7	24.9	-	-
	67	74.5	9.0	70.3	61.3	52.4	43.4	34.4	-	67.3	9.9	66.7	57.9	49.2	40.4	31.7	-
	62	70.1	9.0	70.1	70.1	62.9	53.9	44.9	35.9	64.5	9.9	64.5	64.5	58.1	49.3	40.6	31.8
	57	69.6	9.0	69.6	69.6	63.3	54.4	45.4	36.4	63.9	9.9	63.9	63.9	57.6	48.8	40.1	31.3
2625	77	90.5	9.2	47.4	33.7	23.6	-	-	-	81.1	10.1	45.5	30.1	19.8	-	-	-
	72	83.2	9.1	60.6	50.4	40.3	30.1	-	-	74.5	10.0	56.6	46.7	36.8	26.8	-	-
	67	75.8	9.0	73.7	67.1	56.9	46.8	36.6	-	68.0	9.9	68.0	63.6	53.7	43.8	33.8	-
	62	71.3	9.0	71.3	71.3	68.3	58.2	48.1	37.9	65.2	9.9	65.2	65.2	63.4	53.5	43.6	33.6
	57	70.8	9.0	70.8	70.8	68.9	58.7	48.6	38.4	64.6	9.9	64.6	64.6	62.9	53.0	43.0	33.1
3000	77	92.0	9.2	55.1	36.8	25.5	-	-	-	81.9	10.1	55.4	33.2	21.5	-	-	-
	72	84.6	9.1	66.1	54.8	43.5	32.2	-	-	75.3	10.1	62.0	50.9	39.9	28.8	-	-
	67	77.1	9.1	77.1	72.8	61.5	50.2	38.9	-	68.7	10.0	68.7	68.7	58.2	47.1	36.0	-
	62	72.5	9.0	72.5	72.5	73.8	62.5	51.2	39.9	65.9	9.9	65.9	65.9	65.9	57.6	46.6	35.5
	57	72.0	9.0	72.0	72.0	74.4	63.1	51.8	40.5	65.2	9.9	65.2	65.2	65.2	57.1	46.0	34.9
3375	72	84.3	9.2	70.6	58.4	46.2	34.0	-	-	74.8	10.1	66.0	54.1	42.2	30.3	-	-
	67	76.9	9.1	76.9	74.8	65.3	53.1	41.0	-	68.2	10.0	68.2	68.2	61.6	49.8	37.9	-
	62	72.4	9.0	72.4	72.4	73.0	60.8	48.6	36.4	65.4	10.0	65.4	65.4	65.4	55.0	43.1	31.2
	57	71.8	9.0	71.8	71.8	73.0	60.8	48.7	36.5	64.8	10.0	64.8	64.8	64.8	54.4	42.5	30.6
3750	72	84.1	9.2	75.1	62.0	48.9	35.9	-	-	74.2	10.1	70.0	57.3	44.6	31.9	-	-
	67	76.7	9.1	76.7	76.7	69.2	56.1	43.0	-	67.7	10.0	67.7	67.7	65.1	52.4	39.7	-
	62	72.2	9.1	72.2	72.2	72.2	59.1	46.0	33.0	65.0	10.0	65.0	65.0	65.0	52.3	39.6	26.9
	57	71.7	9.0	71.7	71.7	71.7	58.6	45.5	32.5	64.3	10.0	64.3	64.3	64.3	51.6	38.9	26.2

1. These capacities are gross ratings. For net capacity, deduct air blower motor, MBh = 3.415 x kW. Refer to the appropriate Blower Performance Table for the kW of the supply air blower motor.
2. These ratings include the condenser fan motors (total 1 kW) and the compressor motors but not the supply air blower motor.

J08XP (8.5 Ton)

Air on Evaporator Coil		Temperature of Air on Condenser Coil																	
CFM	WB (°F)	Total Capacity ¹ (MBh)	Total Input (kW) ²	Sensible Capacity (MBh)						Total Capacity ¹ (MBh)	Total Input (kW) ²	Sensible Capacity (MBh)							
				Return Dry Bulb (°F)								Return Dry Bulb (°F)							
				90	85	80	75	70	65			90	85	80	75	70	65		
				75°F						85°F									
2125	77	120.9	6.2	58.3	45.7	36.0	-	-	-	118.6	7.0	52.6	42.8	32.9	-	-	-		
	72	113.7	6.1	69.9	60.2	50.5	40.8	-	-	109.4	6.9	67.3	57.4	47.6	37.7	-	-		
	67	106.4	6.0	81.4	74.6	65.0	55.3	45.6	-	100.2	6.9	82.0	72.1	62.3	52.4	42.5	-		
	62	96.7	5.9	96.7	94.3	79.3	69.6	59.9	50.2	92.3	6.8	92.3	91.1	75.4	65.6	55.7	45.9		
2550	77	126.2	6.2	62.1	51.0	39.8	-	-	-	123.3	7.0	59.3	47.9	36.6	-	-	-		
	72	118.6	6.1	78.1	67.0	55.8	44.7	-	-	113.7	7.0	75.6	64.2	52.9	41.5	-	-		
	67	110.9	6.0	94.1	83.0	71.8	60.7	49.5	-	104.2	6.9	91.9	80.5	69.2	57.8	46.4	-		
	62	100.9	6.0	100.9	99.3	87.7	76.5	65.4	54.3	96.0	6.8	96.0	95.2	83.8	72.4	61.0	49.7		
2975	77	131.4	6.2	65.9	56.2	43.6	-	-	-	128.0	7.0	66.0	53.1	40.2	-	-	-		
	72	123.5	6.1	86.3	73.7	61.2	48.6	-	-	118.1	7.0	83.9	71.0	58.1	45.2	-	-		
	67	115.5	6.0	106.8	91.3	78.7	66.1	53.5	-	108.1	6.9	101.8	89.0	76.1	63.2	50.3	-		
	62	105.1	6.0	105.1	104.3	96.1	83.5	70.9	58.3	99.6	6.9	99.6	99.2	92.2	79.3	66.4	53.5		
3400	77	136.7	6.2	69.7	61.5	47.5	-	-	-	132.7	7.1	72.7	58.3	43.8	-	-	-		
	72	128.4	6.1	94.6	80.5	66.5	52.5	-	-	122.4	7.0	92.2	77.8	63.4	49.0	-	-		
	67	120.1	6.0	119.5	99.6	85.6	71.5	57.5	-	112.1	7.0	111.8	97.4	83.0	68.5	54.1	-		
	62	109.3	6.0	109.3	109.3	104.5	90.4	76.4	62.4	103.3	6.9	103.3	103.3	100.5	86.1	71.7	57.3		
3825	72	132.2	6.2	101.6	86.1	70.7	55.3	-	-	125.5	7.1	99.2	83.4	67.6	51.8	-	-		
	67	123.6	6.1	123.3	106.7	91.0	75.5	60.1	-	115.0	7.0	114.8	104.3	88.4	72.6	56.8	-		
	62	112.5	6.0	112.5	112.5	110.1	94.7	79.2	63.8	105.9	6.9	105.9	105.9	104.5	88.7	72.9	57.1		
	57	111.8	6.0	111.8	111.8	111.0	95.5	80.1	64.7	105.6	6.9	105.6	105.6	104.8	88.9	73.1	57.3		
4250	72	136.0	6.3	108.6	91.8	74.9	58.1	-	-	128.6	7.1	106.2	89.0	71.8	54.5	-	-		
	67	127.2	6.2	127.2	113.8	96.4	79.5	62.7	-	117.8	7.0	117.8	111.1	93.9	76.7	59.4	-		
	62	115.7	6.1	115.7	115.7	115.7	98.9	82.1	65.2	108.6	7.0	108.6	108.6	108.6	91.3	74.1	56.8		
	57	115.0	6.1	115.0	115.0	115.0	98.2	81.4	64.5	108.2	7.0	108.2	108.2	108.2	91.0	73.7	56.5		
				95°F						105°F									
2125	77	116.2	7.8	46.9	39.8	29.8	-	-	-	107.5	8.9	44.1	37.9	28.3	-	-	-		
	72	105.1	7.8	64.7	54.7	44.7	34.7	-	-	97.2	8.8	62.6	52.5	42.4	32.3	-	-		
	67	94.0	7.8	82.5	69.6	59.6	49.5	39.5	-	86.8	8.8	81.1	67.1	56.5	46.4	36.3	-		
	62	87.9	7.7	87.9	87.9	71.6	61.6	51.5	41.5	80.7	8.7	80.7	80.7	68.6	58.5	48.4	38.3		
2550	77	120.4	7.8	56.5	44.9	33.3	-	-	-	111.4	8.9	56.2	43.5	31.8	-	-	-		
	72	108.9	7.8	73.1	61.5	49.9	38.3	-	-	100.6	8.9	71.1	59.4	47.6	35.9	-	-		
	67	97.4	7.8	89.7	78.1	66.5	54.9	43.3	-	89.9	8.8	86.0	75.2	63.5	51.7	40.0	-		
	62	91.1	7.7	91.1	91.1	79.9	68.3	56.7	45.1	83.5	8.7	83.5	83.5	77.0	65.3	53.5	41.8		
2975	77	124.5	7.9	66.1	50.0	36.8	-	-	-	115.2	9.0	68.4	49.2	35.3	-	-	-		
	72	112.6	7.9	81.5	68.3	55.1	41.9	-	-	104.0	8.9	79.7	66.3	52.9	39.4	-	-		
	67	100.7	7.8	96.9	86.6	73.4	60.2	47.0	-	92.9	8.9	91.0	83.4	70.4	57.0	43.6	-		
	62	94.2	7.7	94.2	94.2	88.2	75.0	61.8	48.6	86.4	8.8	86.4	86.4	85.5	72.1	58.7	45.2		
3400	77	128.7	7.9	75.7	55.0	40.2	-	-	-	119.0	9.0	80.5	54.8	38.8	-	-	-		
	72	116.4	7.9	89.9	75.1	60.3	45.5	-	-	107.5	9.0	88.3	73.2	58.1	43.0	-	-		
	67	104.1	7.9	104.1	95.2	80.4	65.6	50.8	-	96.0	8.9	96.0	91.5	77.4	62.3	47.2	-		
	62	97.4	7.8	97.4	97.4	96.6	81.8	67.0	52.2	89.2	8.8	89.2	89.2	93.9	78.9	63.8	48.7		
3825	72	118.8	7.9	96.9	80.7	64.4	48.2	-	-	109.5	9.0	95.4	78.8	62.2	45.6	-	-		
	67	106.3	7.9	106.3	101.8	85.9	69.7	53.4	-	97.8	8.9	97.8	95.6	82.9	66.3	49.7	-		
	62	99.4	7.8	99.4	99.4	99.0	82.8	66.5	50.3	90.9	8.8	90.9	90.9	93.3	76.7	60.1	43.5		
	57	99.4	7.8	99.4	99.4	98.6	82.3	66.1	49.9	92.6	8.8	92.6	92.6	91.9	75.3	58.7	42.1		
4250	72	121.3	7.9	103.9	86.2	68.6	50.9	-	-	111.6	9.0	102.5	84.4	66.3	48.2	-	-		
	67	108.4	7.9	108.4	108.4	91.4	73.8	56.1	-	99.7	8.9	99.7	99.7	88.4	70.3	52.2	-		
	62	101.4	7.8	101.4	101.4	101.4	83.8	66.1	48.4	92.6	8.9	92.6	92.6	92.6	74.6	56.5	38.4		
	57	101.4	7.8	101.4	101.4	101.4	83.8	66.1	48.5	94.4	8.9	94.4	94.4	94.4	76.3	58.2	40.1		

J08XP (8.5 Ton) (Continued)

Air on Evaporator Coil		Temperature of Air on Condenser Coil															
CFM	WB (°F)	Total Capacity ¹ (MBh)	Total Input (kW) ²	Sensible Capacity (MBh)						Total Capacity ¹ (MBh)	Total Input (kW) ²	Sensible Capacity (MBh)					
				Return Dry Bulb (°F)								Return Dry Bulb (°F)					
				90	85	80	75	70	65			90	85	80	75	70	65
				115°F						125°F							
2125	77	98.9	10.0	41.2	36.0	26.8	-	-	-	90.2	11.1	44.1	31.8	25.3	-	-	-
	72	89.2	9.9	60.4	50.3	40.1	30.0	-	-	81.3	11.0	58.2	48.0	37.8	27.6	-	-
	67	79.6	9.8	79.6	64.5	53.4	43.3	33.2	-	72.4	10.9	72.4	62.0	50.4	40.2	30.0	-
	62	73.4	9.7	73.4	73.4	65.6	55.4	45.3	35.2	66.2	10.8	66.2	66.2	66.2	52.3	42.2	32.0
2550	77	102.3	10.0	55.9	42.2	30.3	-	-	-	93.3	11.1	59.4	40.8	28.8	-	-	-
	72	92.4	9.9	69.1	57.3	45.4	33.5	-	-	84.1	11.0	67.2	55.1	43.1	31.1	-	-
	67	82.4	9.8	82.4	72.3	60.5	48.6	36.7	-	74.9	10.9	74.9	69.4	57.4	45.4	33.4	-
	62	76.0	9.8	76.0	76.0	74.1	62.3	50.4	38.5	68.5	10.8	68.5	68.5	68.5	59.2	47.2	35.2
	57	79.1	9.8	79.1	79.1	67.5	55.6	43.7	31.8	73.1	10.8	73.1	73.1	61.6	49.6	37.6	25.5
2975	77	105.8	10.1	70.7	48.4	33.8	-	-	-	96.4	11.2	74.8	49.9	32.3	-	-	-
	72	95.5	10.0	77.9	64.3	50.6	37.0	-	-	86.9	11.0	76.1	62.2	48.4	34.6	-	-
	67	85.1	9.9	85.1	80.1	67.5	53.8	40.2	-	77.3	10.9	77.3	76.9	64.5	50.6	36.8	-
	62	78.5	9.8	78.5	78.5	82.7	69.1	55.5	41.8	70.7	10.8	70.7	70.7	70.7	66.1	52.3	38.5
	57	81.8	9.8	81.8	81.8	75.3	61.6	48.0	34.4	75.6	10.9	75.6	75.6	69.2	55.3	41.5	27.7
3400	77	109.2	10.1	85.4	54.6	37.3	-	-	-	99.5	11.2	90.2	58.9	35.9	-	-	-
	72	98.6	10.0	86.6	71.3	55.9	40.5	-	-	89.7	11.1	85.0	69.4	53.7	38.0	-	-
	67	87.9	9.9	87.9	87.9	74.5	59.1	43.7	-	79.8	10.9	79.8	79.8	71.5	55.8	40.2	-
	62	81.1	9.8	81.1	81.1	91.3	75.9	60.6	45.2	73.0	10.9	73.0	73.0	73.0	73.0	57.4	41.7
	57	84.4	9.9	84.4	84.4	83.1	67.7	52.3	37.0	78.0	10.9	78.0	78.0	76.8	61.1	45.5	29.8
3825	72	100.3	10.0	93.9	76.9	60.0	43.0	-	-	91.0	11.1	91.0	75.1	57.8	40.5	-	-
	67	89.4	9.9	89.4	89.4	79.9	63.0	46.0	-	81.0	11.0	81.0	81.0	76.9	59.6	42.3	-
	62	82.5	9.9	82.5	82.5	87.6	70.7	53.7	36.8	74.0	10.9	74.0	74.0	74.0	64.6	47.3	30.0
	57	85.9	9.9	85.9	85.9	85.2	68.3	51.3	34.4	79.1	10.9	79.1	79.1	78.5	61.2	43.9	26.6
4250	72	101.9	10.1	101.1	82.6	64.1	45.6	-	-	92.3	11.1	92.3	80.8	61.8	42.9	-	-
	67	90.9	10.0	90.9	90.9	85.4	66.8	48.3	-	82.1	11.0	82.1	82.1	82.1	63.4	44.4	-
	62	83.9	9.9	83.9	83.9	83.9	65.4	46.8	28.3	75.1	10.9	75.1	75.1	75.1	56.2	37.2	18.3
	57	87.3	9.9	87.3	87.3	87.3	68.8	50.3	31.8	80.3	11.0	80.3	80.3	80.3	61.3	42.4	23.4

1. These capacities are gross ratings. For net capacity, deduct air blower motor, MBh = 3.415 x kW. Refer to the appropriate Blower Performance Table for the kW of the supply air blower motor.
2. These ratings include the condenser fan motors (total 1 kW) and the compressor motors but not the supply air blower motor.

J10XP (10 Ton)

Air on Evaporator Coil		Temperature of Air on Condenser Coil																	
		Total Capacity ¹ (MBh)	Total Input (kW) ²	Sensible Capacity (MBh)						Total Capacity ¹ (MBh)	Total Input (kW) ²	Sensible Capacity (MBh)							
				Return Dry Bulb (°F)								Return Dry Bulb (°F)							
CFM	WB (°F)			90	85	80	75	70	65			90	85	80	75	70	65		
		75°F									85°F								
2500	77	143.9	7.2	59.2	48.0	36.8	-	-	-	137.1	8.3	60.8	49.9	38.9	-	-	-		
	72	137.2	7.0	79.6	68.4	57.3	46.1	-	-	129.6	8.1	79.2	68.3	57.3	46.4	-	-		
	67	130.5	6.9	100.1	88.9	77.7	66.6	55.4	-	122.0	7.9	97.6	86.7	75.7	64.8	53.8	-		
	62	121.6	6.9	121.6	112.1	92.0	80.8	69.7	58.5	113.8	7.9	113.8	109.1	93.2	82.3	71.3	60.4		
3000	77	147.9	7.2	65.7	53.3	40.8	-	-	-	140.7	8.3	67.3	54.8	42.3	-	-	-		
	72	141.0	7.0	88.3	75.9	63.4	51.0	-	-	133.0	8.1	87.3	74.8	62.2	49.7	-	-		
	67	134.1	6.9	110.9	98.4	86.0	73.5	61.1	-	125.3	7.9	107.2	94.7	82.2	69.7	57.2	-		
	62	124.9	6.9	124.9	118.6	101.9	89.5	77.0	64.6	116.9	7.9	116.9	113.7	101.2	88.7	76.2	63.7		
	57	127.2	6.8	127.2	117.6	105.2	92.7	80.3	67.8	120.0	7.8	120.0	114.3	101.8	89.2	76.7	64.2		
3500	77	151.8	7.2	72.3	58.6	44.9	-	-	-	144.4	8.3	73.8	59.7	45.6	-	-	-		
	72	144.7	7.0	97.0	83.3	69.6	55.8	-	-	136.5	8.1	95.3	81.2	67.2	53.1	-	-		
	67	137.7	6.9	121.7	108.0	94.2	80.5	66.8	-	128.6	7.9	116.9	102.8	88.7	74.6	60.5	-		
	62	128.2	6.9	128.2	125.1	111.8	98.1	84.4	70.6	119.9	7.9	119.9	118.3	109.2	95.1	81.0	66.9		
	57	130.6	6.8	130.6	125.8	115.3	101.6	87.8	74.1	123.2	7.8	123.2	120.3	109.8	95.7	81.6	67.6		
4000	77	155.8	7.2	78.9	63.9	48.9	-	-	-	148.1	8.3	80.3	64.6	49.0	-	-	-		
	72	148.5	7.1	105.7	90.7	75.7	60.7	-	-	139.9	8.1	103.4	87.7	72.1	56.4	-	-		
	67	141.3	6.9	132.5	117.5	102.5	87.5	72.5	-	131.8	8.0	126.5	110.8	95.2	79.5	63.9	-		
	62	131.6	6.9	131.6	131.6	121.7	106.7	91.7	76.7	123.0	7.9	123.0	123.0	117.2	101.5	85.9	70.2		
	57	134.0	6.8	134.0	134.0	125.4	110.4	95.4	80.4	126.3	7.9	126.3	126.3	117.8	102.2	86.5	70.9		
4500	72	144.4	7.1	107.3	92.1	76.8	61.5	-	-	136.6	8.2	107.8	91.5	75.2	59.0	-	-		
	67	137.4	7.0	133.0	120.4	104.1	88.8	73.5	-	128.7	8.0	126.0	115.6	99.3	83.1	66.8	-		
	62	128.0	7.0	128.0	128.0	123.0	107.8	92.5	77.2	120.0	8.0	120.0	120.0	117.1	100.8	84.6	68.3		
	57	130.4	6.9	130.4	130.4	126.0	110.7	95.5	80.2	123.3	7.9	123.3	123.3	119.0	102.8	86.5	70.2		
5000	72	140.3	7.2	109.0	93.4	77.8	62.3	-	-	133.2	8.3	112.1	95.3	78.4	61.5	-	-		
	67	133.5	7.1	133.5	123.4	105.7	90.1	74.5	-	125.5	8.1	125.5	120.4	103.5	86.6	69.8	-		
	62	124.4	7.0	124.4	124.4	124.4	108.8	93.2	77.6	117.0	8.0	117.0	117.0	117.0	100.2	83.3	66.4		
	57	126.7	7.0	126.7	126.7	126.7	111.1	95.5	79.9	120.2	8.0	120.2	120.2	120.2	103.3	86.4	69.6		
		95°F									105°F								
2500	77	130.2	9.3	62.5	51.8	41.1	-	-	-	119.6	10.6	53.1	45.8	35.3	-	-	-		
	72	121.9	9.1	78.8	68.1	57.4	46.7	-	-	112.1	10.4	73.0	62.4	51.9	41.3	-	-		
	67	113.6	8.9	95.1	84.4	73.7	63.0	52.2	-	104.5	10.2	92.9	79.0	68.5	57.9	47.4	-		
	62	106.1	8.9	106.1	106.1	94.4	83.7	73.0	62.3	97.9	10.1	97.9	97.9	84.3	73.7	63.2	52.6		
3000	77	133.6	9.4	68.9	56.3	43.7	-	-	-	122.6	10.6	63.1	50.6	38.0	-	-	-		
	72	125.1	9.2	86.2	73.6	61.1	48.5	-	-	114.9	10.4	81.1	68.5	56.0	43.5	-	-		
	67	116.5	9.0	103.6	91.0	78.4	65.8	53.3	-	107.1	10.2	99.0	86.5	73.9	61.4	48.9	-		
	62	108.8	8.9	108.8	108.8	100.5	87.9	75.3	62.8	100.3	10.1	100.3	100.3	91.0	78.4	65.9	53.3		
	57	112.8	8.9	112.8	110.9	98.4	85.8	73.2	60.6	105.1	10.2	105.1	101.5	88.9	76.4	63.8	51.3		
3500	77	137.0	9.4	75.2	60.8	46.4	-	-	-	125.6	10.6	73.2	55.4	40.8	-	-	-		
	72	128.2	9.2	93.6	79.2	64.8	50.3	-	-	117.7	10.4	89.2	74.7	60.1	45.6	-	-		
	67	119.4	9.0	112.0	97.6	83.1	68.7	54.3	-	109.7	10.2	105.2	94.0	79.4	64.9	50.4	-		
	62	111.6	8.9	111.6	111.6	106.6	92.1	77.7	63.3	102.8	10.1	102.8	102.8	97.7	83.1	68.6	54.0		
	57	115.7	8.9	115.7	114.7	104.3	89.9	75.4	61.0	107.7	10.2	107.7	105.9	95.5	80.9	66.4	51.9		
4000	77	140.4	9.4	81.6	65.3	49.0	-	-	-	128.6	10.6	83.3	60.1	43.6	-	-	-		
	72	131.4	9.2	101.0	84.7	68.4	52.2	-	-	120.5	10.4	97.3	80.8	64.3	47.7	-	-		
	67	122.4	9.0	120.5	104.2	87.9	71.6	55.3	-	112.4	10.2	111.4	101.5	84.9	68.4	51.8	-		
	62	114.3	9.0	114.3	114.3	112.6	96.3	80.0	63.8	105.2	10.2	105.2	105.2	104.3	87.8	71.3	54.7		
	57	118.5	8.9	118.5	118.5	110.3	94.0	77.7	61.4	110.2	10.2	110.2	110.2	102.0	85.5	68.9	52.4		
4500	72	128.7	9.3	108.2	90.9	73.7	56.5	-	-	117.9	10.5	103.1	85.7	68.4	51.0	-	-		
	67	119.9	9.0	118.9	110.8	94.6	77.4	60.1	-	110.0	10.3	109.5	104.5	90.3	73.0	55.7	-		
	62	112.0	9.0	112.0	112.0	111.2	93.9	76.7	59.5	103.0	10.2	103.0	103.0	102.5	85.2	67.8	50.5		
	57	116.1	8.9	116.1	116.1	112.0	94.8	77.5	60.3	107.9	10.2	107.9	107.9	103.8	86.4	69.1	51.8		
5000	72	126.1	9.3	115.3	97.1	78.9	60.8	-	-	115.3	10.5	108.8	90.6	72.5	54.4	-	-		
	67	117.4	9.1	117.4	117.4	101.3	83.2	65.0	-	107.5	10.3	107.5	107.5	95.7	77.6	59.5	-		
	62	109.7	9.0	109.7	109.7	109.7	91.5	73.3	55.2	100.7	10.2	100.7	100.7	100.7	82.6	64.4	46.3		
	57	113.7	9.0	113.7	113.7	113.7	95.6	77.4	59.2	105.5	10.2	105.5	105.5	105.5	87.4	69.2	51.1		

J10XP (10 Ton) (Continued)

Air on Evaporator Coil		Temperature of Air on Condenser Coil															
CFM	WB (°F)	Total Capacity ¹ (MBh)	Total Input (kW) ²	Sensible Capacity (MBh)						Total Capacity ¹ (MBh)	Total Input (kW) ²	Sensible Capacity (MBh)					
				Return Dry Bulb (°F)								Return Dry Bulb (°F)					
				90	85	80	75	70	65			90	85	80	75	70	65
				115°F						125°F							
2500	77	109.0	11.8	43.6	39.8	29.5	-	-	-	98.4	13.1	36.1	32.0	23.6	-	-	-
	72	102.2	11.6	67.1	56.7	46.4	36.0	-	-	92.4	12.9	61.3	51.1	40.8	30.6	-	-
	67	95.4	11.5	90.6	73.6	63.3	52.9	42.5	-	86.4	12.7	86.4	68.3	58.0	47.8	37.6	-
	62	89.6	11.3	89.6	89.6	74.2	63.8	53.4	43.0	81.4	12.6	81.4	81.4	64.0	53.8	43.6	33.4
3000	77	111.7	11.8	57.4	44.9	32.4	-	-	-	100.7	13.1	53.3	39.2	26.7	-	-	-
	72	104.7	11.6	76.0	63.4	50.9	38.4	-	-	94.5	12.9	70.8	58.3	45.9	33.4	-	-
	67	97.7	11.5	94.5	82.0	69.5	57.0	44.5	-	88.4	12.7	88.4	77.5	65.0	52.5	40.1	-
	62	91.8	11.3	91.8	91.8	81.5	68.9	56.4	43.9	83.2	12.6	83.2	83.2	71.9	59.5	47.0	34.5
3500	77	114.3	11.8	71.2	49.9	35.3	-	-	-	102.9	13.0	70.5	46.3	29.7	-	-	-
	72	107.1	11.6	84.8	70.1	55.5	40.8	-	-	96.6	12.9	80.4	65.6	50.9	36.1	-	-
	67	100.0	11.4	98.4	90.4	75.7	61.1	46.4	-	90.3	12.7	90.3	86.8	72.0	57.3	42.5	-
	62	93.9	11.3	93.9	93.9	88.8	74.1	59.5	44.8	85.1	12.5	85.1	85.1	79.9	65.1	50.4	35.6
4000	77	116.9	11.8	85.0	55.0	38.2	-	-	-	105.2	13.0	87.6	53.5	32.7	-	-	-
	72	109.6	11.6	93.6	76.8	60.1	43.3	-	-	98.7	12.8	89.9	72.9	55.9	38.8	-	-
	67	102.3	11.4	102.3	98.7	82.0	65.2	48.4	-	92.3	12.7	92.3	92.3	79.0	62.0	44.9	-
	62	96.1	11.3	96.1	96.1	96.1	79.3	62.5	45.7	86.9	12.5	86.9	86.9	86.9	70.8	53.7	36.7
4500	77	107.1	11.7	97.9	80.5	63.1	45.6	-	-	96.3	12.9	92.8	75.3	57.7	40.2	-	-
	72	100.0	11.5	100.0	98.2	86.0	68.6	51.2	-	90.0	12.7	90.0	90.0	81.8	64.2	46.7	-
	67	93.9	11.4	93.9	93.9	93.9	76.4	59.0	41.6	84.8	12.6	84.8	84.8	84.8	67.7	50.2	32.6
	62	89.6	11.3	89.6	89.6	89.6	78.1	60.6	43.2	81.3	12.5	81.3	81.3	81.3	69.8	52.2	34.7
5000	72	104.6	11.7	102.3	84.2	66.1	48.0	-	-	93.9	13.0	93.9	77.7	59.6	41.6	-	-
	67	97.7	11.5	97.7	97.7	90.1	72.0	53.9	-	87.8	12.8	87.8	87.8	84.5	66.5	48.4	-
	62	91.7	11.4	91.7	91.7	91.7	73.6	55.5	37.4	82.7	12.6	82.7	82.7	82.7	64.6	46.6	28.5
	57	87.3	11.3	87.3	87.3	87.3	79.2	61.1	43.0	81.1	12.5	81.1	81.1	81.1	71.0	52.9	34.9

1. These capacities are gross ratings. For net capacity, deduct air blower motor, MBh = 3.415 x kW. Refer to the appropriate Blower Performance Table for the kW of the supply air blower motor.
2. These ratings include the condenser fan motors (total 1 kW) and the compressor motors but not the supply air blower motor.

J12XP (12.5 Ton)

Air on Evaporator Coil		Temperature of Air on Condenser Coil																	
CFM	WB (°F)	Total Capacity ¹ (MBh)	Total Input (kW) ²	Sensible Capacity (MBh)						Total Capacity ¹ (MBh)	Total Input (kW) ²	Sensible Capacity (MBh)							
				Return Dry Bulb (°F)								Return Dry Bulb (°F)							
				90	85	80	75	70	65			90	85	80	75	70	65		
				75°F						85°F									
3125	77	177.3	9.4	80.2	64.9	49.6	-	-	-	167.8	10.4	77.5	63.0	48.5	-	-	-		
	72	169.6	9.2	105.2	89.8	74.5	59.2	-	-	160.2	10.2	101.1	86.6	72.2	57.7	-	-		
	67	161.9	8.9	130.1	114.8	99.4	84.1	68.8	-	152.6	10.0	124.8	110.3	95.8	81.3	66.8	-		
	62	142.0	8.8	142.0	139.6	120.0	104.6	89.3	74.0	136.6	9.9	136.6	135.4	115.9	101.4	86.9	72.4		
3750	77	185.6	9.5	85.3	69.8	54.4	-	-	-	176.1	10.5	84.2	68.7	53.2	-	-	-		
	72	177.6	9.2	112.7	97.2	81.7	66.2	-	-	168.2	10.3	110.1	94.7	79.2	63.7	-	-		
	67	169.5	9.0	140.0	124.5	109.1	93.6	78.1	-	160.2	10.1	136.1	120.6	105.1	89.6	74.2	-		
	62	148.6	8.9	148.6	147.1	131.6	116.1	100.6	85.1	143.4	9.9	143.4	142.6	127.1	111.7	96.2	80.7		
4375	77	194.0	9.6	90.4	74.8	59.2	-	-	-	184.5	10.6	90.9	74.4	57.9	-	-	-		
	72	185.6	9.3	120.2	104.6	88.9	73.3	-	-	176.1	10.4	119.1	102.7	86.2	69.7	-	-		
	67	177.2	9.1	149.9	134.3	118.7	103.1	87.4	-	167.8	10.2	147.4	130.9	114.4	98.0	81.5	-		
	62	155.3	9.0	155.3	154.5	143.2	127.6	112.0	96.3	150.2	10.0	150.2	149.8	138.4	121.9	105.5	89.0		
5000	77	202.3	9.7	95.5	79.7	64.0	-	-	-	192.8	10.6	97.6	80.1	62.7	-	-	-		
	72	193.6	9.4	127.7	111.9	96.2	80.4	-	-	184.1	10.4	128.1	110.7	93.2	75.8	-	-		
	67	184.8	9.1	159.9	144.1	128.3	112.6	96.8	-	175.4	10.2	158.7	141.2	123.8	106.3	88.9	-		
	62	162.0	9.1	162.0	162.0	154.8	139.1	123.3	107.5	157.0	10.1	157.0	157.0	149.7	132.2	114.8	97.3		
5625	72	196.8	9.5	141.2	122.2	103.2	84.1	-	-	186.4	10.5	140.3	120.3	100.2	80.2	-	-		
	67	187.9	9.2	175.4	156.7	137.7	118.6	99.6	-	177.6	10.3	169.2	153.1	133.1	113.1	93.1	-		
	62	164.7	9.1	164.7	164.7	161.1	142.1	123.1	104.0	159.0	10.1	159.0	159.0	155.3	135.3	115.3	95.3		
	57	172.1	9.2	172.1	172.1	167.9	148.9	129.9	110.8	161.5	10.1	161.5	161.5	158.4	138.4	118.4	98.4		
6250	72	200.0	9.6	154.7	132.4	110.2	87.9	-	-	188.6	10.5	152.4	129.8	107.3	84.7	-	-		
	67	190.9	9.3	190.9	169.3	147.0	124.7	102.4	-	179.7	10.3	179.7	165.0	142.5	119.9	97.3	-		
	62	167.4	9.2	167.4	167.4	167.4	145.1	122.8	100.5	160.9	10.2	160.9	160.9	160.9	138.3	115.8	93.2		
	57	174.9	9.3	174.9	174.9	174.9	152.6	130.3	108.0	163.5	10.2	163.5	163.5	163.5	140.9	118.4	95.8		
				95°F						105°F									
3125	77	158.2	11.4	74.7	61.1	47.4	-	-	-	154.6	12.7	68.2	56.5	43.1	-	-	-		
	72	150.8	11.3	97.1	83.5	69.8	56.2	-	-	145.2	12.6	92.3	78.9	65.5	52.1	-	-		
	67	143.3	11.1	119.5	105.8	92.2	78.5	64.9	-	135.7	12.4	116.4	101.2	87.8	74.4	61.0	-		
	62	131.3	10.9	131.3	131.2	111.8	98.1	84.5	70.8	128.8	12.2	128.8	122.6	104.4	91.0	77.6	64.2		
3750	77	166.6	11.5	83.0	67.5	52.1	-	-	-	161.3	12.8	78.0	62.7	47.5	-	-	-		
	72	158.8	11.3	107.6	92.1	76.6	61.1	-	-	151.5	12.6	102.7	87.4	72.1	56.8	-	-		
	67	150.9	11.2	132.2	116.7	101.2	85.7	70.2	-	141.6	12.5	127.3	112.0	96.7	81.4	66.1	-		
	62	138.2	11.0	138.2	138.2	122.7	107.2	91.7	76.2	134.3	12.3	134.3	130.2	114.9	99.6	84.3	69.0		
4375	77	175.0	11.6	91.3	74.0	56.7	-	-	-	168.0	12.9	87.9	69.0	51.8	-	-	-		
	72	166.7	11.4	118.1	100.8	83.4	66.1	-	-	157.8	12.7	113.1	95.9	78.7	61.5	-	-		
	67	158.5	11.2	144.8	127.5	110.2	92.9	75.6	-	147.5	12.6	138.2	122.8	105.6	88.4	71.2	-		
	62	145.2	11.0	145.2	145.1	133.6	116.3	99.0	81.7	139.8	12.3	139.8	137.8	125.5	108.3	91.1	73.9		
5000	77	183.3	11.6	99.6	80.5	61.3	-	-	-	174.6	12.9	97.8	75.2	56.2	-	-	-		
	72	174.7	11.5	128.6	109.4	90.3	71.1	-	-	164.0	12.8	123.5	104.4	85.3	66.2	-	-		
	67	166.0	11.3	157.5	138.4	119.2	100.1	80.9	-	153.4	12.6	149.2	133.6	114.5	95.4	76.3	-		
	62	152.1	11.1	152.1	152.1	144.5	125.4	106.3	87.1	145.4	12.4	145.4	145.4	136.0	116.9	97.9	78.8		
5625	72	176.0	11.5	139.3	118.3	97.3	76.4	-	-	165.7	12.8	133.3	112.6	91.8	71.0	-	-		
	67	167.3	11.3	163.0	149.5	128.5	107.6	86.6	-	155.0	12.6	152.9	143.1	123.1	102.3	81.5	-		
	62	153.2	11.1	153.2	153.2	149.5	128.5	107.5	86.5	146.9	12.4	146.9	146.9	142.2	121.4	100.6	79.8		
	57	150.9	11.1	150.9	150.9	148.9	127.9	106.9	86.0	144.1	12.4	144.1	144.1	140.9	120.1	99.3	78.5		
6250	72	177.3	11.5	150.0	127.2	104.4	81.6	-	-	167.4	12.8	143.2	120.7	98.2	75.7	-	-		
	67	168.5	11.3	168.5	160.7	137.9	115.1	92.3	-	156.6	12.7	156.6	152.7	131.8	109.3	86.7	-		
	62	154.4	11.1	154.4	154.4	154.4	131.6	108.7	85.9	148.4	12.4	148.4	148.4	148.4	125.9	103.4	80.9		
	57	152.1	11.1	152.1	152.1	152.1	129.2	106.4	83.6	145.5	12.4	145.5	145.5	145.5	123.0	100.5	78.0		

J12XP (12.5 Ton) (Continued)

Air on Evaporator Coil		Temperature of Air on Condenser Coil															
CFM	WB (°F)	Total Capacity ¹ (MBh)	Total Input (kW) ²	Sensible Capacity (MBh)						Total Capacity ¹ (MBh)	Total Input (kW) ²	Sensible Capacity (MBh)					
				Return Dry Bulb (°F)								Return Dry Bulb (°F)					
				90	85	80	75	70	65			90	85	80	75	70	65
				115°F						125°F							
3125	77	151.0	14.0	61.6	51.9	38.8	-	-	-	147.4	15.3	52.9	47.4	34.5	-	-	-
	72	139.6	13.9	87.4	74.3	61.1	48.0	-	-	134.0	15.2	82.6	69.7	56.8	43.9	-	-
	67	128.2	13.7	113.3	96.7	83.5	70.3	57.2	-	120.6	15.0	110.2	92.1	79.2	66.2	53.3	-
	62	126.2	13.5	126.2	114.1	97.0	83.8	70.7	57.5	123.6	14.7	123.6	105.5	89.6	76.7	63.8	50.9
3750	77	156.0	14.1	73.1	57.9	42.8	-	-	-	150.7	15.4	68.1	53.1	38.2	-	-	-
	72	144.2	13.9	97.8	82.6	67.5	52.4	-	-	136.9	15.2	92.8	77.9	63.0	48.1	-	-
	67	132.4	13.8	122.5	107.4	92.2	77.1	62.0	-	123.1	15.1	117.6	102.7	87.8	72.9	57.9	-
	62	130.4	13.5	130.4	122.3	107.2	92.1	77.0	61.9	126.4	14.8	126.4	114.3	99.4	84.5	69.6	54.7
	57	127.3	13.6	127.3	121.7	106.6	91.5	76.4	61.3	122.8	14.9	122.8	114.5	98.1	83.1	68.2	53.3
4375	77	161.0	14.2	84.5	64.0	46.9	-	-	-	154.0	15.4	83.2	58.9	42.0	-	-	-
	72	148.8	14.0	108.1	91.0	74.0	56.9	-	-	139.8	15.3	103.1	86.1	69.2	52.3	-	-
	67	136.6	13.9	131.6	118.1	101.0	83.9	66.9	-	125.7	15.2	125.1	113.3	96.4	79.5	62.5	-
	62	134.5	13.6	134.5	130.5	117.3	100.3	83.2	66.2	129.2	14.9	129.2	123.1	109.2	92.3	75.3	58.4
	57	131.3	13.7	131.3	128.6	116.7	99.7	82.6	65.6	125.5	15.0	125.5	121.3	107.7	90.8	73.9	56.9
5000	77	166.0	14.2	95.9	70.0	51.0	-	-	-	157.3	15.5	98.3	64.7	45.8	-	-	-
	72	153.4	14.1	118.4	99.4	80.4	61.4	-	-	142.8	15.4	113.3	94.3	75.4	56.5	-	-
	67	140.8	13.9	140.8	128.8	109.8	90.7	71.7	-	128.2	15.3	128.2	124.0	105.0	86.1	67.1	-
	62	138.7	13.7	138.7	138.7	127.5	108.5	89.5	70.5	132.0	15.0	132.0	132.0	119.0	100.1	81.1	62.2
	57	135.4	13.7	135.4	135.4	126.8	107.8	88.8	69.8	128.2	15.1	128.2	128.2	117.4	98.5	79.5	60.6
5625	72	155.5	14.1	127.4	106.8	86.2	65.6	-	-	145.2	15.4	121.4	101.0	80.6	60.2	-	-
	67	142.7	14.0	142.7	136.7	117.7	97.1	76.5	-	130.4	15.3	130.4	130.3	112.3	91.9	71.4	-
	62	140.5	13.7	140.5	140.5	135.0	114.3	93.7	73.1	134.2	15.0	134.2	134.2	127.7	107.3	86.9	66.5
	57	137.2	13.7	137.2	137.2	132.9	112.3	91.7	71.1	130.3	15.1	130.3	130.3	124.9	104.5	84.1	63.7
6250	72	157.5	14.1	136.4	114.2	92.0	69.8	-	-	147.6	15.4	129.6	107.7	85.8	63.9	-	-
	67	144.6	14.0	144.6	144.6	125.6	103.4	81.2	-	132.7	15.3	132.7	132.7	119.5	97.6	75.7	-
	62	142.4	13.7	142.4	142.4	142.4	120.2	98.0	75.8	136.4	15.0	136.4	136.4	136.4	114.5	92.6	70.7
	57	139.0	13.7	139.0	139.0	139.0	116.8	94.6	72.4	132.5	15.1	132.5	132.5	132.5	110.6	88.7	66.8

1. These capacities are gross ratings. For net capacity, deduct air blower motor, MBh = 3.415 x kW. Refer to the appropriate Blower Performance Table for the kW of the supply air blower motor.
2. These ratings include the condenser fan motors (total 1 kW) and the compressor motors but not the supply air blower motor.

J06 thru 12XP Heating Capacities

J06 thru 12XP

Size (Tons)	Model	Air Over Evaporator Coil		Capacity ¹ & kW	Outdoor Temperature (°F @ 72% RH)									
		CFM	DB (°F)		-10	0	10	20	30	40	50	60		
J06 (6.5)	XP	1950	55	MBH	10.1	21.7	33.3	44.8	56.4	68.0	79.5	91.1		
			70	KW	4.10	4.30	4.50	4.70	4.89	5.09	5.29	5.49		
				MBH	4.8	16.4	28.0	39.5	51.1	62.7	74.2	85.8		
			80	KW	4.95	5.15	5.35	5.55	5.75	5.94	6.14	6.34		
				MBH	0.9	12.5	24.1	35.7	47.2	58.8	70.4	81.9		
			2600	55	MBH	13.4	25.0	36.6	48.1	59.7	71.3	82.8	94.4	
		70		KW	3.63	3.83	4.03	4.22	4.42	4.62	4.82	5.02		
				MBH	8.0	19.6	31.2	42.7	54.3	65.9	77.4	89.0		
		80		KW	4.45	4.65	4.85	5.05	5.24	5.44	5.64	5.84		
				MBH	4.3	15.8	27.4	39.0	50.5	62.1	73.7	85.2		
		3250		55	MBH	13.8	25.3	36.9	48.5	60.0	71.6	83.2	94.7	
			70	KW	3.25	3.45	3.65	3.85	4.05	4.24	4.44	4.64		
				MBH	8.5	20.0	31.6	43.2	54.7	66.3	77.9	89.5		
			80	KW	4.11	4.30	4.50	4.70	4.90	5.10	5.29	5.49		
				MBH	4.6	16.2	27.7	39.3	50.9	62.4	74.0	85.6		
			KW	4.69	4.89	5.09	5.29	5.48	5.68	5.88	6.08			
		J07 (7.5)	XP	2250	55	MBH	17.4	29.3	41.1	53.0	64.9	76.7	88.6	100.5
					70	KW	5.0	5.2	5.4	5.6	5.9	6.1	6.3	6.5
MBH	15.4					27.3	39.1	51.0	62.8	74.7	86.6	98.4		
80	KW				6.1	6.3	6.5	6.7	6.9	7.1	7.4	7.6		
	MBH				13.0	24.9	36.7	48.6	60.4	72.3	84.2	96.0		
3000	55				MBH	6.9	7.1	7.3	7.5	7.7	7.9	8.1	8.4	
	70			KW	20.1	32.0	43.8	55.7	67.6	79.4	91.3	103.2		
				MBH	4.4	4.6	4.9	5.1	5.3	5.5	5.7	5.9		
	80			KW	18.0	29.9	41.8	53.6	65.5	77.3	89.2	101.1		
				MBH	5.5	5.7	5.9	6.1	6.3	6.6	6.8	7.0		
	3750			55	MBH	15.9	27.7	39.6	51.5	63.3	75.2	87.1	98.9	
70				KW	6.4	6.6	6.8	7.0	7.2	7.4	7.6	7.8		
				MBH	21.2	33.0	44.9	56.7	68.6	80.5	92.3	104.2		
80				KW	4.0	4.2	4.4	4.6	4.8	5.1	5.3	5.5		
				MBH	19.1	31.0	42.9	54.7	66.6	78.5	90.3	102.2		
KW				5.1	5.3	5.5	5.7	5.9	6.1	6.3	6.6			
MBH	16.7			28.6	40.5	52.3	64.2	76.1	87.9	99.8				
KW	5.9			6.1	6.3	6.5	6.7	6.9	7.1	7.3				
J08 (8.5)	XP	2550	55	MBH	9.4	22.3	35.1	48.0	60.8	73.7	86.5	99.4		
			70	KW	4.9	5.1	5.3	5.5	5.7	5.9	6.1	6.3		
				MBH	12.2	25.1	37.9	50.8	63.7	76.5	89.4	102.2		
			80	KW	6.1	6.3	6.5	6.7	6.9	7.1	7.3	7.5		
				MBH	11.1	24.0	36.8	49.7	62.5	75.4	88.2	101.1		
			3400	55	KW	6.9	7.1	7.3	7.5	7.7	7.9	8.2	8.4	
		70		MBH	14.9	27.8	40.6	53.5	66.3	79.2	92.0	104.9		
				KW	4.3	4.5	4.7	4.9	5.2	5.4	5.6	5.8		
		80		MBH	17.7	30.6	43.4	56.3	69.1	82.0	94.8	107.7		
				KW	5.6	5.8	6.0	6.2	6.4	6.6	6.8	7.0		
		4250		55	MBH	16.6	29.4	42.3	55.1	68.0	80.8	93.7	106.6	
			70	KW	6.4	6.6	6.8	7.0	7.2	7.4	7.6	7.8		
				MBH	17.2	30.1	42.9	55.8	68.6	81.5	94.3	107.2		
			80	KW	4.0	4.2	4.4	4.6	4.8	5.0	5.2	5.4		
				MBH	20.0	32.9	45.7	58.6	71.4	84.3	97.1	110.0		
			KW	5.2	5.4	5.6	5.9	6.1	6.3	6.5	6.7			
		MBH	18.9	31.8	44.6	57.5	70.3	83.2	96.0	108.9				
		KW	6.1	6.3	6.5	6.7	6.9	7.1	7.3	7.5				

J06 thru 12XP (Continued)

Size (Tons)	Model	Air Over Evaporator Coil		Capacity ¹ & kW	Outdoor Temperature (°F @ 72% RH)								
		CFM	DB (°F)		-10	0	10	20	30	40	50	60	
J10 (10)	XP	3000	55	MBH	51.3	63.5	75.7	87.9	100.1	112.3	124.5	136.7	
					kW	5.35	5.59	5.83	6.07	6.31	6.55	6.79	7.03
				70	MBH	40.6	52.8	65.0	77.2	89.4	101.6	113.8	126.1
					kW	6.49	6.73	6.97	7.21	7.45	7.69	7.93	8.17
				80	MBH	37.7	50.0	62.2	74.4	86.6	98.8	111.0	123.2
					kW	7.24	7.48	7.72	7.96	8.20	8.44	8.68	8.92
			4000	55	MBH	52.4	64.6	76.8	89.1	101.3	113.5	125.7	137.9
					kW	4.68	4.92	5.16	5.40	5.65	5.89	6.13	6.37
				70	MBH	41.8	54.0	66.2	78.4	90.6	102.8	115.0	127.2
					kW	5.83	6.07	6.31	6.55	6.79	7.03	7.27	7.51
				80	MBH	39.0	51.2	63.4	75.6	87.8	100.0	112.2	124.4
					kW	6.59	6.83	7.07	7.31	7.55	7.79	8.03	8.28
			5000	55	MBH	52.1	64.4	76.6	88.8	101.0	113.2	125.4	137.6
					kW	3.49	3.73	3.97	4.21	4.45	4.70	4.94	5.18
				70	MBH	41.5	53.7	65.9	78.1	90.3	102.5	114.7	126.9
		kW		4.63	4.87	5.11	5.35	5.59	5.84	6.08	6.32		
	80	MBH		38.6	50.8	63.0	75.2	87.4	99.6	111.8	124.0		
		kW		5.38	5.62	5.86	6.11	6.35	6.59	6.83	7.07		
J12 (12.5)	XP	3750	55	MBH	26.6	46.1	65.7	85.2	104.8	124.4	143.9	163.5	
					kW	8.44	8.82	9.21	9.60	9.99	10.38	10.76	11.15
				70	MBH	22.5	42.0	61.6	81.2	100.7	120.3	139.8	159.4
					kW	10.24	10.63	11.02	11.41	11.80	12.18	12.57	12.96
				80	MBH	20.5	40.0	59.6	79.1	98.7	118.2	137.8	157.4
					kW	11.93	12.32	12.71	13.10	13.48	13.87	14.26	14.65
			5000	55	MBH	34.6	54.2	73.7	93.3	112.9	132.4	152.0	171.5
					kW	7.16	7.55	7.94	8.32	8.71	9.10	9.49	9.88
				70	MBH	30.6	50.2	69.7	89.3	108.9	128.4	148.0	167.5
					kW	8.99	9.38	9.77	10.16	10.55	10.93	11.32	11.71
				80	MBH	28.6	48.2	67.7	87.3	106.9	126.4	146.0	165.5
					kW	10.69	11.08	11.46	11.85	12.24	12.63	13.02	13.40
			6250	55	MBH	36.0	55.5	75.1	94.6	114.2	133.8	153.3	172.9
					kW	6.57	6.96	7.35	7.74	8.13	8.51	8.90	9.29
				70	MBH	31.9	51.4	71.0	90.6	110.1	129.7	149.2	168.8
		kW		8.38	8.77	9.16	9.55	9.93	10.32	10.71	11.10		
	80	MBH		29.9	49.4	69.0	88.5	108.1	127.7	147.2	166.8		
		kW		10.07	10.46	10.85	11.23	11.62	12.01	12.40	12.79		

1. These capacities do not include the supply air blower motor heat. For net capacity, add motor heat, MBh = 3.415 x kW.

Airflow Performance

J06 thru 12XP Side Duct Application

J06XP (6.5 Ton) Side Duct

Air Flow (CFM)	Available External Static Pressure - IWG ¹																				
	0.2		0.4		0.6		0.8		1.0		1.2		1.4		1.6		1.8		2.0		
	RPM	BHP	RPM	BHP	RPM	BHP	RPM	BHP	RPM	BHP	RPM	BHP	RPM	BHP	RPM	BHP	RPM	BHP	RPM	BHP	
	FS ⁴				Standard 1.5 HP & Drive						Hi Static 2 HP & Drive										
1800	441	0.44	552	0.54	639	0.63	719	0.72	785	0.81	859	0.99	920	1.16	966	1.25	1018	1.35	1066	1.43	
2000	470	0.48	571	0.59	654	0.69	730	0.79	795	0.89	870	1.09	932	1.25	978	1.35	1030	1.44	1078	1.53	
2200	500	0.54	591	0.66	669	0.76	743	0.87	806	0.97	882	1.18	944	1.35	990	1.44	1042	1.54	1090	1.62	
2400	529	0.60	612	0.73	686	0.85	756	0.96	819	1.07	894	1.29	956	1.45	1002	1.55	1054	1.64	1102	1.73	
2600	558	0.68	635	0.82	705	0.94	771	1.05	832	1.17	906	1.40	968	1.56	1014	1.66	1066	1.75	1114	1.84	
2800	587	0.78	658	0.92	725	1.04	788	1.16	847	1.29	918	1.51	980	1.68	1026	1.77	1078	1.87	1126	1.95	
3000	616	0.88	683	1.02	746	1.15	806	1.28	863	1.41	931	1.63	992	1.80	1038	1.89	1090	1.99	1138	2.07	
3200	645	1.00	710	1.14	768	1.27	825	1.41	879	1.55	943	1.76	1005	1.92	1051	2.02	1103	2.12	1151	2.20	
3400	674	1.14	737	1.27	792	1.40	846	1.55	897	1.70	956	1.89	1018	2.06	1064	2.15	1116	2.25	-	-	
																					FS ⁴

1. Blower performance includes gas heat exchangers and 2" filters. See STATIC RESISTANCE table for additional applications.
2. See RPM SELECTION table to determine desired motor sheave setting and to determine the maximum continuous BHP.
3. kW = BHP x .932.
4. Field Supplied Drive.

J07XP (7.5 Ton) Side Duct

Air Flow (CFM)	Available External Static Pressure - IWG ¹																			
	0.2		0.4		0.6		0.8		1.0		1.2		1.4		1.6		1.8		2.0	
	RPM	BHP	RPM	BHP	RPM	BHP	RPM	BHP	RPM	BHP	RPM	BHP	RPM	BHP	RPM	BHP	RPM	BHP	RPM	BHP
	FS ⁴				Standard 1.5 HP & Drive						Hi Static 3 HP & Drive									
2000	-	-	656	0.24	711	0.48	768	0.73	826	0.96	886	1.19	945	1.41	1003	1.61	1058	1.79	1110	1.95
2200	619	0.07	670	0.32	724	0.57	781	0.81	840	1.04	899	1.27	959	1.49	1016	1.69	1072	1.87	1124	2.04
2400	631	0.16	682	0.41	736	0.66	793	0.90	852	1.14	911	1.36	970	1.58	1028	1.78	1084	1.97	1136	2.13
2600	642	0.27	692	0.52	747	0.76	804	1.01	862	1.24	922	1.47	981	1.69	1039	1.89	1094	2.07	1146	2.24
2800	652	0.39	703	0.64	757	0.88	814	1.13	873	1.36	932	1.59	992	1.81	1049	2.01	1105	2.19	1157	2.36
3000	663	0.53	714	0.77	768	1.02	825	1.26	884	1.50	943	1.73	1003	1.94	1060	2.14	1116	2.33	1168	2.49
3200	675	0.68	726	0.92	780	1.17	837	1.41	896	1.65	955	1.88	1014	2.09	1072	2.29	1128	2.48	1180	2.64
3400	688	0.84	739	1.09	793	1.34	850	1.58	909	1.82	968	2.04	1027	2.26	1085	2.46	1141	2.65	1193	2.81
3600	703	1.03	753	1.28	807	1.52	864	1.76	923	2.00	983	2.23	1042	2.44	1100	2.64	1155	2.83	-	-
3800	718	1.23	769	1.47	823	1.72	880	1.96	939	2.20	998	2.43	1058	2.64	1115	2.84	1171	3.03	-	-

1. Blower performance includes gas heat exchangers and 2" filters. See STATIC RESISTANCE table for additional applications.
2. See RPM SELECTION table to determine desired motor sheave setting and to determine the maximum continuous BHP.
3. kW = BHP x 0.932.
4. Field Supplied Drive.

J08XP (8.5 Ton) Side Duct

Air Flow (CFM)	Available External Static Pressure - IWG ¹																				
	0.2		0.4		0.6		0.8		1.0		1.2		1.4		1.6		1.8		2.0		
	RPM	BHP	RPM	BHP	RPM	BHP	RPM	BHP	RPM	BHP	RPM	BHP	RPM	BHP	RPM	BHP	RPM	BHP	RPM	BHP	
	2 HP & Field Supplied Drive				Standard 2 HP & Drive						Hi Static 3 HP & Drive										
2200	632	0.23	684	0.44	734	0.65	783	0.84	830	1.03	876	1.21	921	1.39	966	1.56	1009	1.74	1051	1.91	
2400	639	0.32	691	0.53	741	0.74	790	0.93	837	1.12	883	1.30	928	1.48	972	1.65	1015	1.83	1058	2.00	
2600	646	0.41	698	0.62	748	0.82	797	1.02	844	1.21	890	1.39	936	1.57	980	1.74	1023	1.92	1065	2.09	
2800	654	0.50	706	0.71	756	0.92	805	1.11	852	1.30	898	1.48	943	1.66	987	1.83	1031	2.01	1073	2.18	
3000	663	0.60	714	0.81	765	1.02	813	1.21	861	1.40	907	1.58	952	1.76	996	1.93	1039	2.11	1082	2.28	
3200	673	0.71	724	0.93	774	1.13	823	1.32	871	1.51	917	1.69	962	1.87	1006	2.05	1049	2.22	1091	2.39	
3400	684	0.84	735	1.05	785	1.25	834	1.45	882	1.63	928	1.82	973	2.00	1017	2.17	1060	2.34	1102	2.52	
3600	696	0.98	747	1.19	798	1.39	846	1.59	894	1.78	940	1.96	985	2.14	1029	2.31	1072	2.48	1115	2.66	
3800	709	1.14	761	1.35	811	1.55	860	1.75	907	1.93	953	2.12	999	2.29	1043	2.47	1086	2.64	1128	2.81	
4000	724	1.31	776	1.52	826	1.72	874	1.92	922	2.11	968	2.29	1013	2.47	1057	2.64	1100	2.82	1143	2.99	
4200	740	1.50	792	1.71	842	1.92	890	2.11	938	2.30	984	2.48	1029	2.66	1073	2.83	1116	3.01	1159	3.18	
																					3 HP & Field Supplied Drive

1. Blower performance includes 2" filters. See STATIC RESISTANCE table for additional applications.
2. See RPM SELECTION table to determine desired motor sheave setting and to determine the maximum continuous BHP.
3. kW = BHP x 0.932.

J10XP (10 Ton) Side Duct

Air Flow (CFM)	Available External Static Pressure - IWG ¹																			
	0.2		0.4		0.6		0.8		1.0		1.2		1.4		1.6		1.8		2.0	
	RPM	BHP	RPM	BHP	RPM	BHP	RPM	BHP	RPM	BHP	RPM	BHP	RPM	BHP	RPM	BHP	RPM	BHP	RPM	BHP
	2 HP & Field Supplied Drive						Standard 2 HP & Drive						Hi Static 3 HP & Drive							
2600	646	0.41	698	0.62	748	0.82	797	1.02	844	1.21	890	1.39	936	1.57	980	1.74	1023	1.92	1065	2.09
2800	654	0.50	706	0.71	756	0.92	805	1.11	852	1.30	898	1.48	943	1.66	987	1.83	1031	2.01	1073	2.18
3000	663	0.60	714	0.81	765	1.02	813	1.21	861	1.40	907	1.58	952	1.76	996	1.93	1039	2.11	1082	2.28
3200	673	0.71	724	0.93	774	1.13	823	1.32	871	1.51	917	1.69	962	1.87	1006	2.05	1049	2.22	1091	2.39
3400	684	0.84	735	1.05	785	1.25	834	1.45	882	1.63	928	1.82	973	2.00	1017	2.17	1060	2.34	1102	2.52
3600	696	0.98	747	1.19	798	1.39	846	1.59	894	1.78	940	1.96	985	2.14	1029	2.31	1072	2.48	1115	2.66
3800	709	1.14	761	1.35	811	1.55	860	1.75	907	1.93	953	2.12	999	2.29	1043	2.47	1086	2.64	1128	2.81
4000	724	1.31	776	1.52	826	1.72	874	1.92	922	2.11	968	2.29	1013	2.47	1057	2.64	1100	2.82	1143	2.99
4200	740	1.50	792	1.71	842	1.92	890	2.11	938	2.30	984	2.48	1029	2.66	1073	2.83	1116	3.01	1159	3.18
4400	757	1.71	809	1.92	859	2.13	908	2.32	955	2.51	1001	2.69	1046	2.87	1091	3.04	1134	3.22	1176	3.39
4600	776	1.94	827	2.15	877	2.35	926	2.55	974	2.74	1020	2.92	1065	3.10	1109	3.27	1152	3.45	-	-
4800	795	2.19	847	2.40	897	2.60	946	2.79	993	2.98	1040	3.16	1085	3.34	-	-	-	-	-	-
5000	816	2.45	868	2.66	918	2.86	967	3.06	1014	3.25	1061	3.43	-	-	-	-	-	-	-	-
													3 HP & Field Supplied Drive							

1. Blower performance includes 2" filters. See STATIC RESISTANCE table for additional applications.
2. See RPM SELECTION table to determine desired motor sheave setting and to determine the maximum continuous BHP.
3. kW = BHP x 0.932.

J12XP (12.5 Ton) Side Duct

Air Flow (CFM)	Available External Static Pressure - IWG ¹																			
	0.2		0.4		0.6		0.8		1.0		1.2		1.4		1.6		1.8		2.0	
	RPM	BHP	RPM	BHP	RPM	BHP	RPM	BHP	RPM	BHP	RPM	BHP	RPM	BHP	RPM	BHP	RPM	BHP	RPM	BHP
	3 HP & Field Supplied Drive						Standard 3 HP & Drive						Hi Static 5 HP & Drive							
3200	673	0.71	724	0.93	774	1.13	823	1.32	871	1.51	917	1.69	962	1.87	1006	2.05	1049	2.22	1091	2.39
3400	684	0.84	735	1.05	785	1.25	834	1.45	882	1.63	928	1.82	973	2.00	1017	2.17	1060	2.34	1102	2.52
3600	696	0.98	747	1.19	798	1.39	846	1.59	894	1.78	940	1.96	985	2.14	1029	2.31	1072	2.48	1115	2.66
3800	709	1.14	761	1.35	811	1.55	860	1.75	907	1.93	953	2.12	999	2.29	1043	2.47	1086	2.64	1128	2.81
4000	724	1.31	776	1.52	826	1.72	874	1.92	922	2.11	968	2.29	1013	2.47	1057	2.64	1100	2.82	1143	2.99
4200	740	1.50	792	1.71	842	1.92	890	2.11	938	2.30	984	2.48	1029	2.66	1073	2.83	1116	3.01	1159	3.18
4400	757	1.71	809	1.92	859	2.13	908	2.32	955	2.51	1001	2.69	1046	2.87	1091	3.04	1134	3.22	1176	3.39
4600	776	1.94	827	2.15	877	2.35	926	2.55	974	2.74	1020	2.92	1065	3.10	1109	3.27	1152	3.45	1194	3.62
4800	795	2.19	847	2.40	897	2.60	946	2.79	993	2.98	1040	3.16	1085	3.34	1129	3.52	1172	3.69	1214	3.86
5000	816	2.45	868	2.66	918	2.86	967	3.06	1014	3.25	1061	3.43	1106	3.61	1150	3.78	1193	3.95	1235	4.13
5200	839	2.73	890	2.94	940	3.14	989	3.34	1037	3.53	1083	3.71	1128	3.89	1172	4.06	1215	4.23	1257	4.41
5400	862	3.03	914	3.24	964	3.44	1012	3.64	1060	3.82	1106	4.01	1151	4.18	1195	4.36	1238	4.53	1281	4.70
5600	886	3.34	938	3.55	988	3.76	1037	3.95	1084	4.14	1131	4.32	1176	4.50	1220	4.67	1263	4.85	1305	5.02
5800	912	3.67	964	3.89	1014	4.09	1063	4.28	1110	4.47	1156	4.65	1201	4.83	1246	5.01	1289	5.18	1331	5.35
6000	939	4.02	990	4.23	1041	4.44	1089	4.63	1137	4.82	1183	5.00	1228	5.18	1272	5.35	1315	5.53	1358	5.70
6200	967	4.39	1018	4.60	1068	4.80	1117	4.99	1165	5.18	1211	5.36	1256	5.54	1300	5.72	-	-	-	-
													5 HP & Field Supplied Drive							

1. Blower performance includes 2" filters. See STATIC RESISTANCE table for additional applications.
2. See RPM SELECTION table to determine desired motor sheave setting and to determine the maximum continuous BHP.
3. kW = BHP x 0.932.

J06 thru 12XP Bottom Duct Application

J06XP (6.5 Ton) Bottom Duct

Air Flow (CFM)	Available External Static Pressure - IWG ¹																			
	0.2		0.4		0.6		0.8		1.0		1.2		1.4		1.6		1.8		2.0	
	RPM	BHP	RPM	BHP	RPM	BHP	RPM	BHP	RPM	BHP	RPM	BHP	RPM	BHP	RPM	BHP	RPM	BHP	RPM	BHP
	FS ⁴				Standard 1.5 HP & Drive				Hi Static 2 HP & Drive											
1800	445	0.63	559	0.66	648	0.69	730	0.72	799	0.75	875	0.89	937	0.99	984	1.05	1038	1.08	1086	1.11
2000	486	0.71	589	0.76	674	0.79	753	0.83	820	0.87	898	1.02	960	1.13	1007	1.18	1061	1.21	1109	1.25
2200	530	0.84	624	0.90	705	0.94	781	0.99	846	1.03	924	1.19	988	1.31	1034	1.35	1088	1.39	1137	1.42
2400	567	0.91	653	0.98	729	1.04	801	1.09	867	1.14	944	1.31	1007	1.41	1055	1.47	1108	1.50	1156	1.54
2600	605	1.02	685	1.10	758	1.16	826	1.21	889	1.27	965	1.45	1028	1.55	1075	1.60	1128	1.63	1178	1.67
2800	645	1.16	719	1.24	788	1.29	854	1.36	915	1.43	988	1.60	1051	1.71	1099	1.75	1151	1.80	1201	1.83
3000	686	1.31	757	1.39	822	1.46	885	1.53	943	1.60	1013	1.77	1076	1.88	1123	1.93	1176	1.97	1225	2.00
3200	729	1.49	797	1.57	858	1.64	917	1.73	972	1.81	1038	1.96	1102	2.07	1149	2.11	1203	2.16	1252	2.19
3400	772	1.70	839	1.77	897	1.84	953	1.93	1005	2.03	1066	2.16	1130	2.27	1177	2.31	1230	2.36		
	FS ⁴																			

1. Blower performance includes gas heat exchangers and 2" filters. See STATIC RESISTANCE table for additional applications.
2. See RPM SELECTION table to determine desired motor sheave setting and to determine the maximum continuous BHP.
3. kW = BHP x .932.
4. Field Supplied Drive.

J07XP (7.5 Ton) Bottom Duct

Air Flow (CFM)	Available External Static Pressure - IWG ¹																			
	0.2		0.4		0.6		0.8		1.0		1.2		1.4		1.6		1.8		2.0	
	RPM	BHP	RPM	BHP	RPM	BHP	RPM	BHP	RPM	BHP	RPM	BHP	RPM	BHP	RPM	BHP	RPM	BHP	RPM	BHP
	FS ⁴				Standard 1.5 HP & Drive				Hi Static 3 HP & Drive											
2000	644	0.11	698	0.38	755	0.62	814	0.85	874	1.06	933	1.26	990	1.46	1043	1.66	1090	1.87	1131	2.09
2200	666	0.26	720	0.53	777	0.77	836	1.00	896	1.21	956	1.41	1012	1.61	1065	1.81	1113	2.02	1153	2.24
2400	689	0.42	743	0.69	800	0.93	859	1.16	919	1.37	978	1.57	1035	1.77	1088	1.97	1135	2.18	1176	2.40
2600	712	0.60	766	0.87	823	1.11	882	1.34	942	1.55	1002	1.75	1058	1.95	1111	2.15	1159	2.36	1199	2.58
2800	736	0.80	790	1.06	847	1.31	906	1.53	967	1.74	1026	1.94	1082	2.14	1135	2.34	1183	2.55	1223	2.78
3000	761	1.00	815	1.27	872	1.52	931	1.74	991	1.95	1051	2.15	1107	2.35	1160	2.55	1208	2.76	1248	2.98
3200	787	1.22	840	1.49	898	1.74	957	1.96	1017	2.17	1076	2.37	1133	2.57	1186	2.77	1233	2.98	1274	3.20
3400	813	1.46	867	1.73	924	1.97	984	2.19	1044	2.40	1103	2.61	1160	2.80	1212	3.01	1260	3.21	-	-
3600	841	1.70	894	1.97	952	2.21	1011	2.44	1071	2.65	1130	2.85	1187	3.05	-	-	-	-	-	-
3800	869	1.96	923	2.22	980	2.47	1039	2.69	1099	2.90	1158	3.10	1215	3.30	-	-	-	-	-	-
	3 HP & Field Supplied Drive																			

1. Blower performance includes gas heat exchangers and 2" filters. See STATIC RESISTANCE table for additional applications.
2. See RPM SELECTION table to determine desired motor sheave setting and to determine the maximum continuous BHP.
3. kW = BHP x 0.932.
4. Field Supplied Drive.

J08XP (8.5 Ton) Bottom Duct

Air Flow (CFM)	Available External Static Pressure - IWG ¹																			
	0.2		0.4		0.6		0.8		1.0		1.2		1.4		1.6		1.8		2.0	
	RPM	BHP	RPM	BHP	RPM	BHP	RPM	BHP	RPM	BHP	RPM	BHP	RPM	BHP	RPM	BHP	RPM	BHP	RPM	BHP
	2 HP & Field Supplied Drive				Standard 2 HP & Drive				Hi Static 3 HP & Drive											
2200	662	0.53	717	0.68	770	0.83	821	0.96	870	1.09	918	1.22	965	1.35	1010	1.47	1055	1.59	1098	1.71
2400	677	0.63	732	0.78	784	0.93	835	1.06	885	1.19	933	1.32	979	1.44	1025	1.57	1069	1.69	1112	1.81
2600	693	0.75	748	0.90	801	1.04	852	1.18	901	1.31	949	1.44	996	1.56	1041	1.68	1085	1.80	1129	1.92
2800	712	0.88	767	1.03	819	1.17	871	1.31	920	1.44	968	1.57	1014	1.69	1060	1.81	1104	1.94	1148	2.06
3000	733	1.03	788	1.18	841	1.33	892	1.46	941	1.59	989	1.72	1036	1.84	1081	1.97	1125	2.09	1169	2.21
3200	757	1.20	811	1.36	864	1.50	915	1.64	964	1.77	1012	1.89	1059	2.02	1104	2.14	1149	2.26	1192	2.38
3400	782	1.40	837	1.55	890	1.69	941	1.83	990	1.96	1038	2.09	1085	2.21	1130	2.33	1174	2.45	1218	2.58
3600	810	1.61	865	1.76	918	1.91	969	2.04	1018	2.18	1066	2.30	1113	2.43	1158	2.55	1203	2.67	1246	2.79
3800	841	1.85	896	2.00	948	2.14	999	2.28	1049	2.41	1097	2.54	1143	2.66	1189	2.78	1233	2.91	1276	3.03
4000	874	2.11	928	2.26	981	2.40	1032	2.54	1082	2.67	1130	2.80	1176	2.92	1222	3.04	1266	3.16	1309	3.28
4200	909	2.38	963	2.53	1016	2.68	1067	2.81	1117	2.95	1164	3.07	1211	3.20	1256	3.32	1301	3.44	-	-
	3 HP & Field Supplied Drive																			

1. Blower performance includes 2" filters. See STATIC RESISTANCE table for additional applications.
2. See RPM SELECTION table to determine desired motor sheave setting and to determine the maximum continuous BHP.
3. kW = BHP x 0.932.

J10XP (10 Ton) Bottom Duct

Air Flow (CFM)	Available External Static Pressure - IWG ¹																			
	0.2		0.4		0.6		0.8		1.0		1.2		1.4		1.6		1.8		2.0	
	RPM	BHP	RPM	BHP	RPM	BHP	RPM	BHP	RPM	BHP	RPM	BHP	RPM	BHP	RPM	BHP	RPM	BHP	RPM	BHP
	2 HP & Field Supplied Drive				Standard 2 HP & Drive						Hi Static 3 HP & Drive									
2600	693	0.75	748	0.90	801	1.04	852	1.18	901	1.31	949	1.44	996	1.56	1041	1.68	1085	1.80	1129	1.92
2800	712	0.88	767	1.03	819	1.17	871	1.31	920	1.44	968	1.57	1014	1.69	1060	1.81	1104	1.94	1148	2.06
3000	733	1.03	788	1.18	841	1.33	892	1.46	941	1.59	989	1.72	1036	1.84	1081	1.97	1125	2.09	1169	2.21
3200	757	1.20	811	1.36	864	1.50	915	1.64	964	1.77	1012	1.89	1059	2.02	1104	2.14	1149	2.26	1192	2.38
3400	782	1.40	837	1.55	890	1.69	941	1.83	990	1.96	1038	2.09	1085	2.21	1130	2.33	1174	2.45	1218	2.58
3600	810	1.61	865	1.76	918	1.91	969	2.04	1018	2.18	1066	2.30	1113	2.43	1158	2.55	1203	2.67	1246	2.79
3800	841	1.85	896	2.00	948	2.14	999	2.28	1049	2.41	1097	2.54	1143	2.66	1189	2.78	1233	2.91	1276	3.03
4000	874	2.11	928	2.26	981	2.40	1032	2.54	1082	2.67	1130	2.80	1176	2.92	1222	3.04	1266	3.16	1309	3.28
4200	909	2.38	963	2.53	1016	2.68	1067	2.81	1117	2.95	1164	3.07	1211	3.20	1256	3.32	1301	3.44	-	-
4400	946	2.68	1000	2.83	1053	2.98	1104	3.11	1154	3.24	1202	3.37	-	-	-	-	-	-	-	-
4600	985	3.00	1040	3.15	1092	3.29	1143	3.43	-	-	-	-	-	-	-	-	-	-	-	-
4800	1026	3.33	-	-	-	-	-	-	-	-	-	-	-	-	-	-	-	-	-	-
	3 HP & Field Supplied Drive																			

1. Blower performance includes 2" filters. See STATIC RESISTANCE table for additional applications.
2. See RPM SELECTION table to determine desired motor sheave setting and to determine the maximum continuous BHP.
3. kW = BHP x 0.932.

J12XP (12.5 Ton) Bottom Duct

Air Flow (CFM)	Available External Static Pressure - IWG ¹																			
	0.2		0.4		0.6		0.8		1.0		1.2		1.4		1.6		1.8		2.0	
	RPM	BHP	RPM	BHP	RPM	BHP	RPM	BHP	RPM	BHP	RPM	BHP	RPM	BHP	RPM	BHP	RPM	BHP	RPM	BHP
	3 HP & Field Supplied Drive				Standard 3 HP & Drive						Hi Static 5 HP & Drive									
3200	757	1.20	811	1.36	864	1.50	915	1.64	964	1.77	1012	1.89	1059	2.02	1104	2.14	1149	2.26	1192	2.38
3400	782	1.40	837	1.55	890	1.69	941	1.83	990	1.96	1038	2.09	1085	2.21	1130	2.33	1174	2.45	1218	2.58
3600	810	1.61	865	1.76	918	1.91	969	2.04	1018	2.18	1066	2.30	1113	2.43	1158	2.55	1203	2.67	1246	2.79
3800	841	1.85	896	2.00	948	2.14	999	2.28	1049	2.41	1097	2.54	1143	2.66	1189	2.78	1233	2.91	1276	3.03
4000	874	2.11	928	2.26	981	2.40	1032	2.54	1082	2.67	1130	2.80	1176	2.92	1222	3.04	1266	3.16	1309	3.28
4200	909	2.38	963	2.53	1016	2.68	1067	2.81	1117	2.95	1164	3.07	1211	3.20	1256	3.32	1301	3.44	1344	3.56
4400	946	2.68	1000	2.83	1053	2.98	1104	3.11	1154	3.24	1202	3.37	1248	3.49	1294	3.62	1338	3.74	1381	3.86
4600	985	3.00	1040	3.15	1092	3.29	1143	3.43	1193	3.56	1241	3.69	1287	3.81	1333	3.93	1377	4.05	1420	4.18
4800	1026	3.33	1081	3.48	1133	3.63	1184	3.76	1234	3.90	1282	4.02	1328	4.15	1374	4.27	1418	4.39	1461	4.51
5000	1069	3.69	1124	3.84	1177	3.98	1228	4.12	1277	4.25	1325	4.38	1372	4.50	1417	4.62	1461	4.74	1505	4.87
5200	1114	4.06	1169	4.21	1222	4.35	1273	4.49	1322	4.62	1370	4.75	1417	4.87	1462	5.00	1506	5.12	1550	5.24
5400	1161	4.45	1216	4.60	1268	4.74	1319	4.88	1369	5.01	1417	5.14	1463	5.26	1509	5.38	1553	5.51	1596	5.63
5600	1210	4.86	1264	5.01	1317	5.15	1368	5.29	1418	5.42	1465	5.55	1512	5.67	-	-	-	-	-	-
5800	1260	5.28	1315	5.43	1367	5.57	1418	5.71	-	-	-	-	-	-	-	-	-	-	-	-
	5 HP & Field Supplied Drive																			

1. Blower performance includes 2" filters. See STATIC RESISTANCE table for additional applications.
2. See RPM SELECTION table to determine desired motor sheave setting and to determine the maximum continuous BHP.
3. kW = BHP x 0.932.

RPM Selection

Size (Tons)	Model	HP	Max BHP	Motor Sheave	Blower Sheave	6 Turns Open	5 Turns Open	4 Turns Open	3 Turns Open	2 Turns Open	1 Turn Open	Fully Closed
J06 (6.5)	XP	1.5	1.73	VL40	AK84	NA	576	618	661	702	748	792
		2	2.30	VL44	AK71	NA	790	843	887	936	989	1041
J07 (7.5)	XP	1.5	1.73	1VL40	AK69	N/A	690	743	796	849	902	955
		3	3.45	1VM50	AK69	N/A	955	1008	1062	1115	1168	1221
J08 (8.5)	XP	2	2.30	1VP50	AK89	N/A	735	775	815	851	889	930
		3	3.45	1VP50	AK74	N/A	880	928	972	1016	1067	1110
J10 (10)	XP	2	2.30	1VM50	AK84	N/A	785	821	858	901	940	980
		3	3.45	1VM50	AK74	N/A	880	928	972	1016	1067	1110
J12 (12.5)	XP	3	3.45	1VM50	AK74	N/A	880	928	972	1016	1067	1110
		5	5.75	1VP56	BK77	1052	1095	1136	1175	1216	1272	N/A

Additional Static Resistance

Size (Tons)	Model	CFM	Economizer ^{1 2}	4" Filter ¹	Electric Heat kW ¹				
					9	18	24	36	54
J06 (6.5) J07 (7.5) J08 (8.5) J10 (10) J12 (12.5)	XP	1900	0.02	0.12	0.05	0.06	0.07	0.08	0.10
		2100	0.02	0.13	0.06	0.07	0.08	0.09	0.11
		2300	0.04	0.14	0.07	0.08	0.09	0.10	0.13
		2500	0.11	0.16	0.08	0.09	0.10	0.11	0.14
		2700	0.18	0.17	0.09	0.10	0.12	0.13	0.16
		2900	0.25	0.19	0.10	0.11	0.13	0.14	0.18
		3100	0.31	0.20	0.12	0.13	0.15	0.16	0.20
		3300	0.37	0.22	0.13	0.14	0.17	0.18	0.22
		3500	0.43	0.26	0.15	0.16	0.19	0.20	0.24
		3700	0.49	0.27	0.17	0.18	0.21	0.22	0.26
		3900	0.54	0.29	0.19	0.20	0.23	0.24	0.28
		4100	0.58	0.32	0.21	0.22	0.25	0.26	0.31
		4300	0.65	0.35	0.23	0.24	0.28	0.29	0.34
		4500	0.69	0.38	0.25	0.26	0.30	0.31	0.37
		4700	0.74	0.41	0.28	0.29	0.33	0.34	0.40
		4900	0.78	0.44	0.30	0.31	0.35	0.37	0.43
		5100	0.82	0.47	0.33	0.34	0.38	0.40	0.46
		5300	0.86	0.51	0.35	0.37	0.41	0.43	0.49
		5500	0.89	0.55	0.38	0.40	0.44	0.46	0.53
		5700	0.93	0.58	0.41	0.43	0.47	0.49	0.56
5900	0.96	0.62	0.44	0.46	0.50	0.53	0.59		
6100	0.98	0.67	0.47	0.49	0.53	0.56	0.62		
6300	1.01	0.71	0.50	0.53	0.56	0.59	0.65		

1. Deduct these values from the available external static pressure shown in the respective Blower Performance Tables.
2. The pressure drop through the economizer is greater for 100% outdoor air than for 100% return air. If the resistance of the return air duct is less than 0.25 IWG, the unit will deliver less CFM during full economizer operation.

Drive Selection

1. Determine side or bottom supply duct Application.
2. Determine desired airflow.
3. Calculate or measure the amount of external static pressure.
4. Using the operating point determined from steps 1, 2 & 3, locate this point on the appropriate supply air blower performance table. (Linear interpolation may be necessary.)
5. Noting the RPM and BHP from step 4, locate the appropriate motor and, or drive on the RPM selection table.
6. Review the BHP compared to the motor options available. Select the appropriate motor and, or drive.
7. Review the RPM range for the motor options available. Select the appropriate drive if multiple drives are available for the chosen motor.
8. Determine turns open to obtain the desired operation point.

Example

1. 2600 CFM
2. 1.6 iwg
3. Using the supply air blower performance table below, the following data point was located: 1268 RPM & 1.95 BHP.
4. Using the RPM selection table below, Size X and Model Y is found.
5. 1.95 BHP exceeds the maximum continuous BHP rating of the 1.5 HP motor. The 2 HP motor is required.
6. 1268 RPM is within the range of the 2 HP drives.
7. Using the 2 HP motor and drive, .5 turns open will achieve 1268 RPM.

Airflow Performance**Example Supply Air Blower Performance**

Air Flow (CFM)	Available External Static Pressure - IWG																			
	0.2		0.4		0.6		0.8		1.0		1.2		1.4		1.6		1.8		2.0	
	RPM	BHP	RPM	BHP	RPM	BHP	RPM	BHP	RPM	BHP	RPM	BHP	RPM	BHP	RPM	BHP	RPM	BHP	RPM	BHP
	1.5 HP & Field Supplied Drive						Standard 1.5 HP & Drive						Alternate 2 HP & Drive							
2200	804	0.50	866	0.71	925	0.90	982	1.06	1038	1.21	1092	1.35	1147	1.48	1203	1.61	1259	1.73	1317	1.87
2400	835	0.66	897	0.87	956	1.06	1013	1.22	1069	1.37	1124	1.51	1178	1.64	1234	1.77	1290	1.90	1348	2.03
2600	869	0.84	931	1.05	990	1.24	1047	1.40	1103	1.55	1158	1.69	1212	1.82	1268	1.95	1324	2.07	1382	2.21
2800	906	1.03	968	1.25	1027	1.43	1084	1.60	1139	1.75	1194	1.89	1249	2.02	1304	2.14	1361	2.27	-	-

Table X: RPM Selection

Size (Tons)	Model	HP	Max BHP	Motor Sheave	Blower Sheave	6 Turns Open	5 Turns Open	4 Turns Open	3 Turns Open	2 Turns Open	1 Turn Open	Fully Closed
X	Y	1.5	1.73	1VM50	AK74	N/A	897	945	991	1035	1079	1126
		2	2.30	1VM50	AK64	N/A	1039	1094	1150	1207	1256	1308

Altitude/Temperature Correction Factors

Air Temp.	Altitude (Ft.)										
	0	1000	2000	3000	4000	5000	6000	7000	8000	9000	10000
40	1.060	1.022	0.986	0.950	0.916	0.882	0.849	0.818	0.788	0.758	0.729
50	1.039	1.002	0.966	0.931	0.898	0.864	0.832	0.802	0.772	0.743	0.715
60	1.019	0.982	0.948	0.913	0.880	0.848	0.816	0.787	0.757	0.729	0.701
70	1.000	0.964	0.930	0.896	0.864	0.832	0.801	0.772	0.743	0.715	0.688
80	0.982	0.947	0.913	0.880	0.848	0.817	0.787	0.758	0.730	0.702	0.676
90	0.964	0.929	0.897	0.864	0.833	0.802	0.772	0.744	0.716	0.689	0.663
100	0.946	0.912	0.880	0.848	0.817	0.787	0.758	0.730	0.703	0.676	0.651

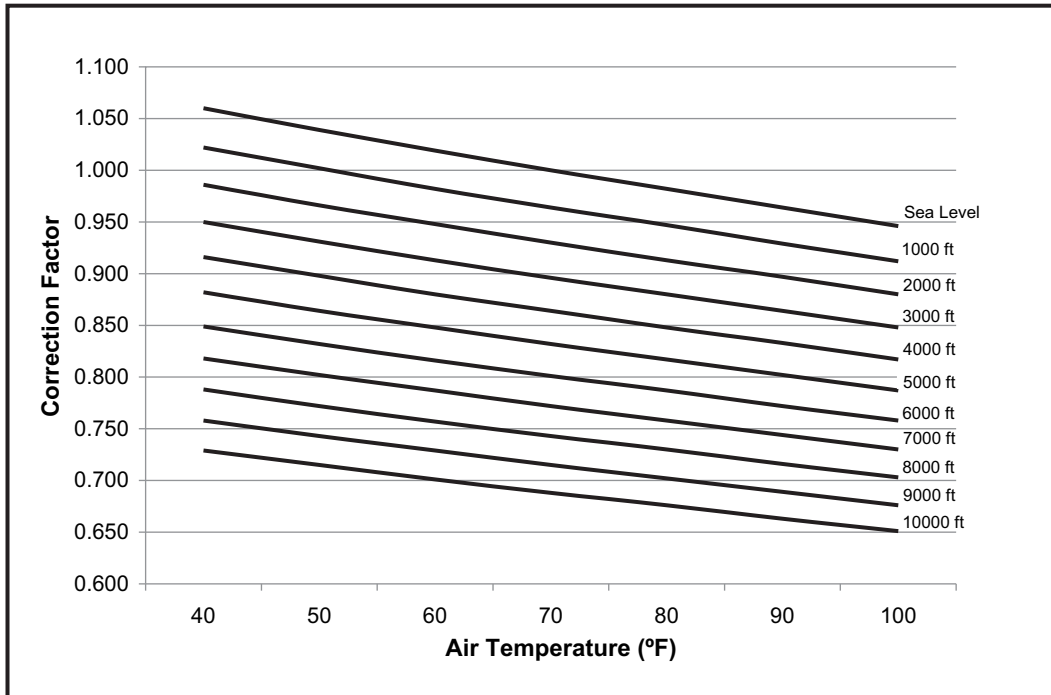

Electric Heat Minimum Supply Air

Size (Tons)	Model	Voltage	Minimum Supply Air (CFM)				
			Heater kW				
			9	18	24	36	54
J06 (6.5)	XP	208/230-3-60	1950	1950	1950	1950	-
		460-3-60	1950	1950	1950	1950	-
		600-3-60	1950	1950	1950	1950	-
J07 (7.5)	XP	208/230-3-60	2250	2250	2250	2250	-
		460-3-60	2250	2250	2250	2250	-
		600-3-60	2250	2250	2250	2250	-
J08 (8.5)	XP	208/230-3-60	2550	2550	2550	2550	-
		460-3-60	2550	2550	2550	2550	-
		600-3-60	2550	2550	2550	2550	-
J10 (10)	XP	208/230-3-60	-	3000	3000	3000	3500
		460-3-60	-	3000	3000	3000	3000
		600-3-60	-	3000	3000	3000	3500
J12 (12.5)	XP	208/230-3-60	-	3750	3750	3750	4000
		460-3-60	-	3750	3750	3750	3750
		600-3-60	-	3750	3750	3750	3750

Indoor Blower Specifications

Size (Tons)	Model	Motor					Motor Sheave			Blower Sheave			Belt
		HP	RPM	Eff.	SF	Frame	Datum Dia. (in.)	Bore (in.)	Model	Datum Dia. (in.)	Bore (in.)	Model	
J06 (6.5)	XP	1-1/2	1725	0.8	1.15	56	2.4 - 3.4	7/8	VL40	8.1	1	AK84	A54
		2	1725	0.8	1.15	56	2.8 - 3.8	7/8	VL44	6.7	1	AK71	A52
J07 (7.5)	XP	1-1/2	1725	0.8	1.15	56	2.6 - 3.6	7/8	1VL40	6.5	1	AK69	A52
		3	1725	0.8	1.15	56	3.6 - 4.6	7/8	1VM50	6.5	1	AK69	A54
J08 (8.5)	XP	2	1725	0.8	1.15	56	3.4 - 4.4	7/8	1VP50	8.5	1	AK89	A56
		3	1725	0.8	1.15	56	3.4 - 4.4	7/8	1VP50	7.0	1	AK74	A54
J10 (10)	XP	2	1725	0.8	1.15	56	3.4 - 4.4	7/8	1VM50	8.0	1	AK84	A56
		3	1725	0.8	1.15	56	3.4 - 4.4	7/8	1VM50	7.0	1	AK74	A54
J12 (12.5)	XP	3	1725	0.8	1.15	56	3.4 - 4.4	7/8	1VM50	7.0	1	AK74	A54
		5	1725	0.87	1.15	184T	4.3 - 5.3	1-1/8	1VP56	6.7	1	BK77	BX56

Power Exhaust Specifications

Model	Voltage	Motor			Motor			Fuse Size	CFM @ 0.1 ESP
		HP	RPM ¹	QTY	LRA	FLA	MCA		
2PE04703225	208/230-1-60	3/4	1075	1	7.8	5	6.3	10	3800
2PE04703246	460-1-60	3/4	1075	1	3.4	2.2	2.8	5	3800
2PE04703258	575-1-60	3/4	1050	1	2.9	1.5	1.9	4	3800

1. Motors are multi-tapped and factory wired for high speed.

Electric Heat Multipliers

Voltage		kW Capacity Multipliers ¹
Nominal	Applied	
240	208	0.75
	230	0.92
480	460	0.92
600	575	0.92

1. Electric heaters are rated at nominal voltage. Use this table to determine the electric heat capacity for heaters applied at lower voltages.

Sound Performance

Indoor Sound Power Levels

Size (Tons)	Model	CFM	ESP (IWG)	Blower		Sound Power, dB (10 ⁻¹²) Watts								
						RPM	BHP	Sound Rating ¹ dB (A)	Octave Band Centerline Frequency (Hz)					
				63	125				250	500	1000	2000	4000	8000
J06 (6.5)	XP	2600	0.6	812	1.14	74	71	73	73	71	69	65	65	60
J07 (7.5)	XP	3000	0.6	854	1.47	77	74	76	76	74	72	68	68	63
J08 (8.5)	XP	3400	0.6	872	1.65	80	77	79	79	77	75	71	71	66
J10 (10)	XP	4000	0.6	959	2.29	83	80	82	82	80	78	74	74	69
J12 (12.5)	XP	5000	0.6	1132	3.74	87	84	86	86	84	82	78	78	73

1. These values have been accessed using a model of sound propagation from a point source into the hemispheric/free field. The dBA values provided are to be used for reference only. Calculation of dBA values cover matters of system design and the fan manufacture has no way of knowing the details of each system. This constitutes an exception to any specification or guarantee requiring a dBA value of sound data in any other form than sound power level ratings.

Outdoor Sound Power Levels

Size (Tons)	Model	Sound Rating ¹ dB (A)	Octave Band Centerline Frequency (Hz)						
			125	250	500	1000	2000	4000	8000
J06 (6.5)	XP	83	88.0	82.5	81.5	78.0	73.0	69.0	62.0
J07 (7.5)	XP	83	89.5	83.5	82.0	78.0	72.5	68.0	60.5
J08 (8.5)	XP	83	89.0	84.5	81.5	78.0	72.5	68.5	70.5
J10 (10)	XP	83	89.5	83.5	81.0	78.0	72.0	68.5	70.5
J12 (12.5)	XP	84	90.0	84.5	81.5	77.5	72.0	68.5	61.5

1. Rated in accordance with AHRI 270 standard.

Electrical Data

J06 thru 12XP Standard Motor - Without Powered Convenience Outlet

Size (Tons)	Volt	Compressors (each)			OD Fan Motors (each)	Supply Blower Motor	Pwr Exh Motor	Pwr Conv Outlet	Electric Heat Option				MCA ¹ (Amps)	MCA ¹ w/Pwr Exh (Amps)	Max Fuse ² / Breaker ³ Size (Amps)	Max Fuse ¹ / Breaker ³ Size w/ Pwr Exh (Amps)
		RLA	LRA	MCC	FLA	FLA	FLA	FLA	Model	kW	Stages	Amps				
J06 (6.5)	208	13.5	88.0	15.1	1.5	6.2	5.5	0.0	None	-	-	-	39.6	45.1	50	50
									E09	6.8	1	18.9	63.2	68.7	70	70
									E18	13.5	2	37.5	86.4	91.9	90	100
									E24	18.0	2	50.0	102.0	107.5	110	110
									E36	25.5	2	70.8	128.1	133.6	150	150
	230	13.5	88.0	15.1	1.5	6.2	5.5	0.0	None	-	-	-	39.6	45.1	50	50
									E09	9.0	1	21.7	66.6	72.1	70	80
									E18	18.0	2	43.3	93.7	99.2	100	100
									E24	24.0	2	57.7	111.7	117.2	125	125
									E36	34.0	2	81.8	141.8	147.3	150	150
	460	6.0	44.0	9.3	0.8	3.1	2.2	0.0	None	-	-	-	18.2	20.4	20	25
									E09	9.0	1	10.8	31.7	33.9	35	35
									E18	18.0	2	21.7	45.3	47.5	50	50
									E24	24.0	2	28.9	54.3	56.5	60	60
									E36	34.0	2	40.9	69.3	71.5	70	80
	575	4.9	34.0	7.7	0.6	2.4	1.8	0.0	None	-	-	-	14.6	16.4	15	20
									E09	9.0	1	8.7	25.5	27.3	30	30
									E18	18.0	2	17.3	36.3	38.1	40	40
									E24	24.0	2	23.1	43.5	45.3	45	50
									E36	34.0	2	32.7	55.5	57.3	60	60
J07 (7.5)	208	15.6	83.1	21.4	1.5	6.0	5.5	0.0	None	-	-	-	44.1	49.6	50	60
									E09	6.8	1	18.9	67.7	73.2	70	80
									E18	13.5	2	37.5	90.9	96.4	100	100
									E24	18	2	50.0	106.6	112.1	110	125
									E36	25.5	2	70.8	132.6	138.1	150	150
	230	15.6	83.1	21.4	1.5	6.0	5.5	0.0	None	-	-	-	44.1	49.6	50	60
									E09	9	1	21.7	71.2	76.7	80	80
									E18	18	2	43.3	98.2	103.7	100	110
									E24	24	2	57.7	116.3	121.8	125	125
									E36	34	2	81.8	146.3	151.8	150	175
	460	6.9	41.0	9.7	0.8	3.0	2.2	0.0	None	-	-	-	20.1	22.3	25	25
									E09	9	1	10.8	33.7	35.9	35	40
									E18	18	2	21.7	47.2	49.4	50	50
									E24	24	2	28.9	56.2	58.4	60	60
									E36	34	2	40.9	71.2	73.4	80	80
	575	5.4	33.0	7.5	0.6	2.4	1.8	0.0	None	-	-	-	15.8	17.6	20	20
									E09	9	1	8.7	26.6	28.4	30	30
									E18	18	2	17.3	37.4	39.2	40	40
									E24	24	2	23.1	44.6	46.4	45	50
									E36	34	2	32.7	56.6	58.4	60	60
J08 (8.5)	208	14.5	98.0	22.6	1.5	8.2	5.5	0.0	None	-	-	-	43.8	49.3	50	60
									E09	6.8	1	18.9	67.4	72.9	70	80
									E18	13.5	2	37.5	90.7	96.2	100	100
									E24	18	2	50.0	106.3	111.8	110	125
									E36	25.5	2	70.8	132.3	137.8	150	150
	230	14.5	98.0	22.6	1.5	8.2	5.5	0.0	None	-	-	-	43.8	49.3	50	60
									E09	9	1	21.7	70.9	76.4	80	80
									E18	18	2	43.3	98.0	103.5	100	110
									E24	24	2	57.7	116.0	121.5	125	125
									E36	34	2	81.8	146.1	151.6	150	175
	460	6.3	55.0	9.9	0.8	4.1	2.2	0.0	None	-	-	-	19.9	22.1	25	25
									E09	9	1	10.8	33.4	35.6	35	40
									E18	18	2	21.7	46.9	49.1	50	50
									E24	24	2	28.9	56.0	58.2	60	60
									E36	34	2	40.9	71.0	73.2	80	80
	575	6.0	41.0	9.4	0.6	3.6	1.8	0.0	None	-	-	-	18.3	20.1	20	25
									E09	9	1	8.7	29.1	30.9	30	35
									E18	18	2	17.3	40.0	41.8	40	45
									E24	24	2	23.1	47.2	49.0	50	50
									E36	34	2	32.7	59.2	61.0	60	70

J06 thru 12XP Standard Motor - Without Powered Convenience Outlet (Continued)

Size (Tons)	Volt	Compressors (each)			OD Fan Motors (each)	Supply Blower Motor	Pwr Exh Motor	Pwr Conv Outlet	Electric Heat Option				MCA ¹ (Amps)	MCA ¹ w/Pwr Exh (Amps)	Max Fuse ² / Breaker ³ Size (Amps)	Max Fuse ¹ / Breaker ³ Size w/ Pwr Exh (Amps)
		RLA	LRA	MCC	FLA	FLA	FLA	FLA	Model	kW	Stages	Amps				
J10 (10)	208	16.0	110.0	24.9	1.5	8.2	5.5	0.0	None	-	-	-	47.2	52.7	60	60
									E18	13.5	2	37.5	94.0	99.5	100	100
									E24	18.0	2	50.0	109.7	115.2	110	125
									E36	25.5	2	70.8	135.7	141.2	150	150
									E54	40.6	2	112.7	151.1	158.0	175	175
	230	16.0	110.0	24.9	1.5	8.2	5.5	0.0	None	-	-	-	47.2	52.7	60	60
									E18	18.0	2	43.3	101.3	106.8	110	110
									E24	24.0	2	57.7	119.4	124.9	125	125
									E36	34.0	2	81.8	149.4	154.9	150	175
									E54	54.0	2	129.9	149.4	154.9	150	175
	460	7.8	52.0	12.1	0.8	4.1	2.2	0.0	None	-	-	-	23.3	25.5	30	30
									E18	18.0	2	21.7	50.3	52.5	60	60
									E24	24.0	2	28.9	59.3	61.5	60	70
									E36	34.0	2	40.9	74.4	76.6	80	80
									E54	54.0	2	65.0	74.4	76.6	80	80
	575	5.7	38.9	8.9	0.6	3.6	1.8	0.0	None	-	-	-	17.6	19.4	20	25
									E18	18.0	2	17.3	39.3	41.1	40	45
									E24	24.0	2	23.1	46.5	48.3	50	50
									E36	34.0	2	32.7	58.5	60.3	60	70
									E54	54.0	2	52.0	58.5	60.3	60	70
J12 (12.5)	208	22.4	149.0	35.0	1.5	10.9	5.5	0.0	None	-	-	-	67.3	72.8	80	90
									E18	13.5	2	37.5	114.1	119.6	125	125
									E24	18	2	50.0	129.8	135.3	150	150
									E36	25.5	2	70.8	155.8	161.3	175	175
									E54	40.6	2	112.7	155.8	161.4	175	175
	230	22.4	149.0	35.0	1.5	10.9	5.5	0.0	None	-	-	-	67.3	72.8	80	90
									E18	18	2	43.3	121.4	126.9	125	150
									E24	24	2	57.7	139.5	145.0	150	150
									E36	34	2	81.8	169.5	175.0	175	175
									E54	54	2	129.9	169.5	175.0	175	175
	460	10.6	75.0	16.5	0.8	5.3	2.2	0.0	None	-	-	-	32.4	34.6	40	45
									E18	18	2	21.7	59.4	61.6	60	70
									E24	24	2	28.9	68.4	70.6	70	80
									E36	34	2	40.9	83.5	85.7	90	90
									E54	54	2	65.0	83.5	85.7	90	90
	575	7.7	54.0	12.0	0.6	4.1	1.8	0.0	None	-	-	-	23.8	25.6	30	30
									E18	18	2	17.3	45.5	47.3	50	50
									E24	24	2	23.1	52.7	54.5	60	60
									E36	34	2	32.7	64.7	66.5	70	70
									E54	54	2	52.0	64.7	66.5	70	70

1. Minimum Circuit Ampacity.
2. Dual Element, Time Delay Type.
3. HACR type per NEC.

J06 thru 12XP Hi Static Motor - Without Powered Convenience Outlet

Size (Tons)	Volt	Compressors (each)			OD Fan Motors (each)	Supply Blower Motor	Pwr Exh Motor	Pwr Conv Outlet	Electric Heat Option				MCA ¹ (Amps)	MCA ¹ w/Pwr Exh (Amps)	Max Fuse ² / Breaker ³ Size (Amps)	Max Fuse ² / Breaker ³ Size w/ Pwr Exh (Amps)
		RLA	LRA	MCC	FLA	FLA	FLA	FLA	Model	kW	Stages	Amps				
J06 (6.5)	208	13.5	88.0	15.1	1.5	8.2	5.5	0.0	None	-	-	-	41.6	47.1	50	60
									E09	6.8	1	18.9	65.2	70.7	70	80
									E18	13.5	2	37.5	88.4	93.9	90	100
									E24	18.0	2	50.0	104.0	109.5	110	110
									E36	25.5	2	70.8	130.1	135.6	150	150
	230	13.5	88.0	15.1	1.5	8.2	5.5	0.0	None	-	-	-	41.6	47.1	50	60
									E09	9.0	1	21.7	68.6	74.1	70	80
									E18	18.0	2	43.3	95.7	101.2	100	110
									E24	24.0	2	57.7	113.7	119.2	125	125
									E36	34.0	2	81.8	143.8	149.3	150	150
	460	6.0	44.0	9.3	0.8	4.1	2.2	0.0	None	-	-	-	19.2	21.4	25	25
									E09	9.0	1	10.8	32.7	34.9	35	35
									E18	18.0	2	21.7	46.3	48.5	50	50
									E24	24.0	2	28.9	55.3	57.5	60	60
									E36	34.0	2	40.9	70.3	72.5	80	80
	575	4.9	34.0	7.7	0.6	3.6	1.8	0.0	None	-	-	-	15.8	17.6	20	20
									E09	9.0	1	8.7	26.7	28.5	30	30
									E18	18.0	2	17.3	37.5	39.3	40	40
									E24	24.0	2	23.1	44.7	46.5	45	50
									E36	34.0	2	32.7	56.7	58.5	60	60
J07 (7.5)	208	15.6	83.1	21.4	1.5	9.6	5.5	0.0	None	-	-	-	47.7	53.2	60	60
									E09	6.8	1	18.9	71.3	76.8	80	80
									E18	13.5	2	37.5	94.5	100.0	100	100
									E24	18	2	50.0	110.2	115.7	125	125
									E36	25.5	2	70.8	136.2	141.7	150	150
	230	15.6	83.1	21.4	1.5	9.6	5.5	0.0	None	-	-	-	47.7	53.2	60	60
									E09	9	1	21.7	74.8	80.3	80	90
									E18	18	2	43.3	101.8	107.3	110	110
									E24	24	2	57.7	119.9	125.4	125	150
									E36	34	2	81.8	149.9	155.4	150	175
	460	6.9	41.0	9.7	0.8	4.8	2.2	0.0	None	-	-	-	21.9	24.1	25	30
									E09	9	1	10.8	35.5	37.7	40	40
									E18	18	2	21.7	49.0	51.2	50	60
									E24	24	2	28.9	58.0	60.2	60	70
									E36	34	2	40.9	73.0	75.2	80	80
	575	5.4	33.0	7.5	0.6	3.9	1.8	0.0	None	-	-	-	17.3	19.1	20	20
									E09	9	1	8.7	28.1	29.9	30	30
									E18	18	2	17.3	38.9	40.7	40	45
									E24	24	2	23.1	46.1	47.9	50	50
									E36	34	2	32.7	58.1	59.9	60	60
J08 (8.5)	208	14.5	98.0	22.6	1.5	10.9	5.5	0.0	None	-	-	-	46.5	52.0	60	60
									E09	6.8	1	18.9	70.1	75.6	80	80
									E18	13.5	2	37.5	93.4	98.9	100	100
									E24	18	2	50.0	109.0	114.5	110	125
									E36	25.5	2	70.8	135.0	140.5	150	150
	230	14.5	98.0	22.6	1.5	10.9	5.5	0.0	None	-	-	-	46.5	52.0	60	60
									E09	9	1	21.7	73.6	79.1	80	80
									E18	18	2	43.3	100.7	106.2	110	110
									E24	24	2	57.7	118.7	124.2	125	125
									E36	34	2	81.8	148.8	154.3	150	175
	460	6.3	55.0	9.9	0.8	5.3	2.2	0.0	None	-	-	-	21.1	23.3	25	25
									E09	9	1	10.8	34.6	36.8	35	40
									E18	18	2	21.7	48.1	50.3	50	60
									E24	24	2	28.9	57.2	59.4	60	60
									E36	34	2	40.9	72.2	74.4	80	80
	575	6.0	41.0	9.4	0.6	4.1	1.8	0.0	None	-	-	-	18.8	20.6	20	25
									E09	9	1	8.7	29.6	31.4	30	35
									E18	18	2	17.3	40.5	42.3	45	45
									E24	24	2	23.1	47.7	49.5	50	50
									E36	34	2	32.7	59.7	61.5	60	70

J06 thru 12XP Hi Static Motor - Without Powered Convenience Outlet (Continued)

Size (Tons)	Volt	Compressors (each)			OD Fan Motors (each)	Supply Blower Motor	Pwr Exh Motor	Pwr Conv Outlet	Electric Heat Option				MCA ¹ (Amps)	MCA ¹ w/Pwr Exh (Amps)	Max Fuse ^{2/} Breaker ³ Size (Amps)	Max Fuse ^{2/} Breaker ³ Size w/ Pwr Exh (Amps)
		RLA	LRA	MCC	FLA	FLA	FLA	FLA	Model	kW	Stages	Amps				
J10 (10)	208	16.0	110.0	24.9	1.5	10.9	5.5	0.0	None	-	-	-	49.9	55.4	60	70
									E18	13.5	2	37.5	96.7	102.2	100	110
									E24	18.0	2	50.0	112.4	117.9	125	125
									E36	25.5	2	70.8	138.4	143.9	150	150
									E54	40.6	2	112.7	154.5	161.4	175	175
	230	16.0	110.0	24.9	1.5	10.9	5.5	0.0	None	-	-	-	49.9	55.4	60	70
									E18	18.0	2	43.3	104.0	109.5	110	110
									E24	24.0	2	57.7	122.1	127.6	125	150
									E36	34.0	2	81.8	152.1	157.6	175	175
									E54	54.0	2	129.9	152.1	157.6	175	175
	460	7.8	52.0	12.1	0.8	5.3	2.2	0.0	None	-	-	-	24.5	26.7	30	30
									E18	18.0	2	21.7	51.5	53.7	60	60
									E24	24.0	2	28.9	60.5	62.7	70	70
									E36	34.0	2	40.9	75.6	77.8	80	80
									E54	54.0	2	65.0	75.6	77.8	80	80
	575	5.7	38.9	8.9	0.6	4.1	1.8	0.0	None	-	-	-	18.1	19.9	20	25
									E18	18.0	2	17.3	39.8	41.6	40	45
									E24	24.0	2	23.1	47.0	48.8	50	50
									E36	34.0	2	32.7	59.0	60.8	60	70
									E54	54.0	2	52.0	59.0	60.8	60	70
J12 (12.5)	208	22.4	149.0	35.0	1.5	16.1	5.5	0.0	None	-	-	-	72.5	78.0	90	100
									E18	13.5	2	37.5	119.3	124.8	125	125
									E24	18	2	50.0	135.0	140.5	150	150
									E36	25.5	2	70.8	161.0	166.5	175	175
									E54	40.6	2	112.7	161.0	167.9	175	175
	230	22.4	149.0	35.0	1.5	16.1	5.5	0.0	None	-	-	-	72.5	78.0	90	100
									E18	18	2	43.3	126.6	132.1	150	150
									E24	24	2	57.7	144.7	150.2	150	175
									E36	34	2	81.8	174.7	180.2	175	200
									E54	54	2	129.9	174.7	180.2	175	200
	460	10.6	75.0	16.5	0.8	8.1	2.2	0.0	None	-	-	-	35.2	37.4	45	45
									E18	18	2	21.7	62.2	64.4	70	70
									E24	24	2	28.9	71.2	73.4	80	80
									E36	34	2	40.9	86.3	88.5	90	90
									E54	54	2	65.0	86.3	88.5	90	90
	575	7.7	54.0	12.0	0.6	6.0	1.8	0.0	None	-	-	-	25.7	27.5	30	35
									E18	18	2	17.3	47.4	49.2	50	50
									E24	24	2	23.1	54.6	56.4	60	60
									E36	34	2	32.7	66.6	68.4	70	70
									E54	54	2	52.0	66.6	68.4	70	70

1. Minimum Circuit Ampacity.
2. Dual Element, Time Delay Type.
3. HACR type per NEC.

J06 thru 12XP Standard Motor - With Powered Convenience Outlet

Size (Tons)	Volt	Compressors (each)			OD Fan Motors (each)	Supply Blower Motor	Pwr Exh Motor	Pwr Conv Outlet	Electric Heat Option				MCA ¹ (Amps)	MCA ¹ w/Pwr Exh (Amps)	Max Fuse ² / Breaker ³ Size (Amps)	Max Fuse ² / Breaker ³ Size w/ Pwr Exh (Amps)
		RLA	LRA	MCC	FLA	FLA	FLA	FLA	Model	kW	Stages	Amps				
J06 (6.5)	208	13.5	88.0	15.1	1.5	6.2	5.5	10.0	None	-	-	-	49.6	55.1	60	60
									E09	6.8	1	18.9	73.2	78.7	80	80
									E18	13.5	2	37.5	96.4	101.9	100	110
									E24	18.0	2	50.0	112.0	117.5	125	125
									E36	25.5	2	70.8	138.1	143.6	150	150
	230	13.5	88.0	15.1	1.5	6.2	5.5	10.0	None	-	-	-	49.6	55.1	60	60
									E09	9.0	1	21.7	76.6	82.1	80	90
									E18	18.0	2	43.3	103.7	109.2	110	110
									E24	24.0	2	57.7	121.7	127.2	125	150
									E36	34.0	2	81.8	151.8	157.3	175	175
	460	6.0	44.0	9.3	0.8	3.1	2.2	5.0	None	-	-	-	23.2	25.4	25	30
									E09	9.0	1	10.8	36.7	38.9	40	40
									E18	18.0	2	21.7	50.3	52.5	60	60
									E24	24.0	2	28.9	59.3	61.5	60	70
									E36	34.0	2	40.9	74.3	76.5	80	80
	575	4.9	34.0	7.7	0.6	2.4	1.8	4.0	None	-	-	-	18.6	20.4	20	25
									E09	9.0	1	8.7	29.5	31.3	30	35
									E18	18.0	2	17.3	40.3	42.1	45	45
									E24	24.0	2	23.1	47.5	49.3	50	50
									E36	34.0	2	32.7	59.5	61.3	60	70
J07 (7.5)	208	15.6	83.1	21.4	1.5	6.0	5.5	10.0	None	-	-	-	54.1	59.6	60	70
									E09	6.8	1	18.9	77.7	83.2	80	90
									E18	13.5	2	37.5	100.9	106.4	110	110
									E24	18	2	50.0	116.6	122.1	125	125
									E36	25.5	2	70.8	142.6	148.1	150	150
	230	15.6	83.1	21.4	1.5	6.0	5.5	10.0	None	-	-	-	54.1	59.6	60	70
									E09	9	1	21.7	81.2	86.7	90	90
									E18	18	2	43.3	108.2	113.7	110	125
									E24	24	2	57.7	126.3	131.8	150	150
									E36	34	2	81.8	156.3	161.8	175	175
	460	6.9	41.0	9.7	0.8	3.0	2.2	5.0	None	-	-	-	25.1	27.3	30	30
									E09	9	1	10.8	38.7	40.9	40	45
									E18	18	2	21.7	52.2	54.4	60	60
									E24	24	2	28.9	61.2	63.4	70	70
									E36	34	2	40.9	76.2	78.4	80	80
	575	5.4	33.0	7.5	0.6	2.4	1.8	4.0	None	-	-	-	19.8	21.6	25	25
									E09	9	1	8.7	30.6	32.4	35	35
									E18	18	2	17.3	41.4	43.2	45	45
									E24	24	2	23.1	48.6	50.4	50	60
									E36	34	2	32.7	60.6	62.4	70	70
J08 (8.5)	208	14.5	98.0	22.6	1.5	8.2	5.5	10.0	None	-	-	-	53.8	59.3	60	70
									E09	6.8	1	18.9	77.4	82.9	80	90
									E18	13.5	2	37.5	100.7	106.2	110	110
									E24	18	2	50.0	116.3	121.8	125	125
									E36	25.5	2	70.8	142.3	147.8	150	150
	230	14.5	98.0	22.6	1.5	8.2	5.5	10.0	None	-	-	-	53.8	59.3	60	70
									E09	9	1	21.7	80.9	86.4	90	90
									E18	18	2	43.3	108.0	113.5	110	125
									E24	24	2	57.7	126.0	131.5	150	150
									E36	34	2	81.8	156.1	161.6	175	175
	460	6.3	55.0	9.9	0.8	4.1	2.2	5.0	None	-	-	-	24.9	27.1	30	30
									E09	9	1	10.8	38.4	40.6	40	45
									E18	18	2	21.7	51.9	54.1	60	60
									E24	24	2	28.9	61.0	63.2	70	70
									E36	34	2	40.9	76.0	78.2	80	80
	575	6.0	41.0	9.4	0.6	3.6	1.8	4.0	None	-	-	-	22.3	24.1	25	30
									E09	9	1	8.7	33.1	34.9	35	35
									E18	18	2	17.3	44.0	45.8	45	50
									E24	24	2	23.1	51.2	53.0	60	60
									E36	34	2	32.7	63.2	65.0	70	70

J06 thru 12XP Standard Motor - With Powered Convenience Outlet (Continued)

Size (Tons)	Volt	Compressors (each)			OD Fan Motors (each)	Supply Blower Motor	Pwr Exh Motor	Pwr Conv Outlet	Electric Heat Option				MCA ¹ (Amps)	MCA ¹ w/Pwr Exh (Amps)	Max Fuse ² / Breaker ³ Size (Amps)	Max Fuse ² / Breaker ³ Size w/ Pwr Exh (Amps)
		RLA	LRA	MCC	FLA	FLA	FLA	FLA	Model	kW	Stages	Amps				
J10 (10)	208	16.0	110.0	24.9	1.5	8.2	5.5	10.0	None	-	-	-	57.2	62.7	70	70
									E18	13.5	2	37.5	104.0	109.5	110	110
									E24	18.0	2	50.0	119.7	125.2	125	150
									E36	25.5	2	70.8	145.7	151.2	150	175
									E54	40.6	2	112.7	163.6	170.5	175	175
	230	16.0	110.0	24.9	1.5	8.2	5.5	10.0	None	-	-	-	57.2	62.7	70	70
									E18	18.0	2	43.3	111.3	116.8	125	125
									E24	24.0	2	57.7	129.4	134.9	150	150
									E36	34.0	2	81.8	159.4	164.9	175	175
									E54	54.0	2	129.9	159.4	164.9	175	175
	460	7.8	52.0	12.1	0.8	4.1	2.2	5.0	None	-	-	-	28.3	30.5	35	35
									E18	18.0	2	21.7	55.3	57.5	60	60
									E24	24.0	2	28.9	64.3	66.5	70	70
									E36	34.0	2	40.9	79.4	81.6	80	90
									E54	54.0	2	65.0	79.4	81.6	80	90
	575	5.7	38.9	8.9	0.6	3.6	1.8	4.0	None	-	-	-	21.6	23.4	25	25
									E18	18.0	2	17.3	43.3	45.1	45	50
									E24	24.0	2	23.1	50.5	52.3	60	60
									E36	34.0	2	32.7	62.5	64.3	70	70
									E54	54.0	2	52.0	62.5	64.3	70	70
J12 (12.5)	208	22.4	149.0	35.0	1.5	10.9	5.5	10.0	None	-	-	-	77.3	82.8	90	100
									E18	13.5	2	37.5	124.1	129.6	125	150
									E24	18	2	50.0	139.8	145.3	150	150
									E36	25.5	2	70.8	165.8	171.3	175	175
									E54	40.6	2	112.7	167.0	173.9	175	175
	230	22.4	149.0	35.0	1.5	10.9	5.5	10.0	None	-	-	-	77.3	82.8	90	100
									E18	18	2	43.3	131.4	136.9	150	150
									E24	24	2	57.7	149.5	155.0	150	175
									E36	34	2	81.8	179.5	185.0	200	200
									E54	54	2	129.9	179.5	185.0	200	200
	460	10.6	75.0	16.5	0.8	5.3	2.2	5.0	None	-	-	-	37.4	39.6	45	50
									E18	18	2	21.7	64.4	66.6	70	70
									E24	24	2	28.9	73.4	75.6	80	80
									E36	34	2	40.9	88.5	90.7	90	100
									E54	54	2	65.0	88.5	90.7	90	100
	575	7.7	54.0	12.0	0.6	4.1	1.8	4.0	None	-	-	-	27.8	29.6	35	35
									E18	18	2	17.3	49.5	51.3	50	60
									E24	24	2	23.1	56.7	58.5	60	60
									E36	34	2	32.7	68.7	70.5	70	80
									E54	54	2	52.0	68.7	70.5	70	80

1. Minimum Circuit Ampacity.
2. Dual Element, Time Delay Type.
3. HACR type per NEC.

J06 thru 12XP Hi Static Motor - With Powered Convenience Outlet

Size (Tons)	Volt	Compressors (each)			OD Fan Motors (each)	Supply Blower Motor	Pwr Exh Motor	Pwr Conv Outlet	Electric Heat Option				MCA ¹ (Amps)	MCA ¹ w/Pwr Exh (Amps)	Max Fuse ² / Breaker ³ Size (Amps)	Max Fuse ² / Breaker ³ Size w/ Pwr Exh (Amps)
		RLA	LRA	MCC	FLA	FLA	FLA	FLA	Model	kW	Stages	Amps				
J06 (6.5)	208	13.5	88.0	15.1	1.5	8.2	5.5	10.0	None	-	-	-	51.6	57.1	60	70
									E09	6.8	1	18.9	75.2	80.7	80	90
									E18	13.5	2	37.5	98.4	103.9	100	110
									E24	18.0	2	50.0	114.0	119.5	125	125
									E36	25.5	2	70.8	140.1	145.6	150	150
	230	13.5	88.0	15.1	1.5	8.2	5.5	10.0	None	-	-	-	51.6	57.1	60	70
									E09	9.0	1	21.7	78.6	84.1	80	90
									E18	18.0	2	43.3	105.7	111.2	110	125
									E24	24.0	2	57.7	123.7	129.2	125	150
									E36	34.0	2	81.8	153.8	159.3	175	175
	460	6.0	44.0	9.3	0.8	4.1	2.2	5.0	None	-	-	-	24.2	26.4	30	30
									E09	9.0	1	10.8	37.7	39.9	40	40
									E18	18.0	2	21.7	51.3	53.5	60	60
									E24	24.0	2	28.9	60.3	62.5	70	70
									E36	34.0	2	40.9	75.3	77.5	80	80
	575	4.9	34.0	7.7	0.6	3.6	1.8	4.0	None	-	-	-	19.8	21.6	20	25
									E09	9.0	1	8.7	30.7	32.5	35	35
									E18	18.0	2	17.3	41.5	43.3	45	45
									E24	24.0	2	23.1	48.7	50.5	50	60
									E36	34.0	2	32.7	60.7	62.5	70	70
J07 (7.5)	208	15.6	83.1	21.4	1.5	9.6	5.5	10.0	None	-	-	-	57.7	63.2	70	70
									E09	6.8	1	18.9	81.3	86.8	90	90
									E18	13.5	2	37.5	104.5	110.0	110	110
									E24	18	2	50.0	120.2	125.7	125	150
									E36	25.5	2	70.8	146.2	151.7	150	175
	230	15.6	83.1	21.4	1.5	9.6	5.5	10.0	None	-	-	-	57.7	63.2	70	70
									E09	9	1	21.7	84.8	90.3	90	100
									E18	18	2	43.3	111.8	117.3	125	125
									E24	24	2	57.7	129.9	135.4	150	150
									E36	34	2	81.8	159.9	165.4	175	175
	460	6.9	41.0	9.7	0.8	4.8	2.2	5.0	None	-	-	-	26.9	29.1	30	35
									E09	9	1	10.8	40.5	42.7	45	45
									E18	18	2	21.7	54.0	56.2	60	60
									E24	24	2	28.9	63.0	65.2	70	70
									E36	34	2	40.9	78.0	80.2	80	90
	575	5.4	33.0	7.5	0.6	3.9	1.8	4.0	None	-	-	-	21.3	23.1	25	25
									E09	9	1	8.7	32.1	33.9	35	35
									E18	18	2	17.3	42.9	44.7	45	45
									E24	24	2	23.1	50.1	51.9	60	60
									E36	34	2	32.7	62.1	63.9	70	70
J08 (8.5)	208	14.5	98.0	22.6	1.5	10.9	5.5	10.0	None	-	-	-	56.5	62.0	70	70
									E09	6.8	1	18.9	80.1	85.6	90	90
									E18	13.5	2	37.5	103.4	108.9	110	110
									E24	18	2	50.0	119.0	124.5	125	125
									E36	25.5	2	70.8	145.0	150.5	150	175
	230	14.5	98.0	22.6	1.5	10.9	5.5	10.0	None	-	-	-	56.5	62.0	70	70
									E09	9	1	21.7	83.6	89.1	90	90
									E18	18	2	43.3	110.7	116.2	125	125
									E24	24	2	57.7	128.7	134.2	150	150
									E36	34	2	81.8	158.8	164.3	175	175
	460	6.3	55.0	9.9	0.8	5.3	2.2	5.0	None	-	-	-	26.1	28.3	30	30
									E09	9	1	10.8	39.6	41.8	40	45
									E18	18	2	21.7	53.1	55.3	60	60
									E24	24	2	28.9	62.2	64.4	70	70
									E36	34	2	40.9	77.2	79.4	80	80
	575	6.0	41.0	9.4	0.6	4.1	1.8	4.0	None	-	-	-	22.8	24.6	25	30
									E09	9	1	8.7	33.6	35.4	35	40
									E18	18	2	17.3	44.5	46.3	45	50
									E24	24	2	23.1	51.7	53.5	60	60
									E36	34	2	32.7	63.7	65.5	70	70

J06 thru 12XP Hi Static Motor - With Powered Convenience Outlet (Continued)

Size (Tons)	Volt	Compressors (each)			OD Fan Motors (each)	Supply Blower Motor	Pwr Exh Motor	Pwr Conv Outlet	Electric Heat Option				MCA ¹ (Amps)	MCA ¹ w/Pwr Exh (Amps)	Max Fuse ² / Breaker ³ Size (Amps)	Max Fuse ² / Breaker ³ Size w/ Pwr Exh (Amps)
		RLA	LRA	MCC	FLA	FLA	FLA	FLA	Model	kW	Stages	Amps				
J10 (10)	208	16.0	110.0	24.9	1.5	10.9	5.5	10.0	None	-	-	-	59.9	65.4	70	80
									E18	13.5	2	37.5	106.7	112.2	110	125
									E24	18.0	2	50.0	122.4	127.9	125	150
									E36	25.5	2	70.8	148.4	153.9	150	175
									E54	40.6	2	112.7	167.0	173.9	175	175
	230	16.0	110.0	24.9	1.5	10.9	5.5	10.0	None	-	-	-	59.9	65.4	70	80
									E18	18.0	2	43.3	114.0	119.5	125	125
									E24	24.0	2	57.7	132.1	137.6	150	150
									E36	34.0	2	81.8	162.1	167.6	175	175
									E54	54.0	2	129.9	162.1	167.6	175	175
	460	7.8	52.0	12.1	0.8	5.3	2.2	5.0	None	-	-	-	29.5	31.7	35	35
									E18	18.0	2	21.7	56.5	58.7	60	60
									E24	24.0	2	28.9	65.5	67.7	70	70
									E36	34.0	2	40.9	80.6	82.8	90	90
									E54	54.0	2	65.0	80.6	82.8	90	90
	575	5.7	38.9	8.9	0.6	4.1	1.8	4.0	None	-	-	-	22.1	23.9	25	25
									E18	18.0	2	17.3	43.8	45.6	45	50
									E24	24.0	2	23.1	51.0	52.8	60	60
									E36	34.0	2	32.7	63.0	64.8	70	70
									E54	54.0	2	52.0	63.0	64.8	70	70
J12 (12.5)	208	22.4	149.0	35.0	1.5	16.1	5.5	10.0	None	-	-	-	82.5	88.0	100	110
									E18	13.5	2	37.5	129.3	134.8	150	150
									E24	18	2	50.0	145.0	150.5	150	175
									E36	25.5	2	70.8	171.0	176.5	175	200
									E54	40.6	2	112.7	173.5	180.4	175	200
	230	22.4	149.0	35.0	1.5	16.1	5.5	10.0	None	-	-	-	82.5	88.0	100	110
									E18	18	2	43.3	136.6	142.1	150	150
									E24	24	2	57.7	154.7	160.2	175	175
									E36	34	2	81.8	184.7	190.2	200	200
									E54	54	2	129.9	184.7	190.2	200	200
	460	10.6	75.0	16.5	0.8	8.1	2.2	5.0	None	-	-	-	40.2	42.4	50	50
									E18	18	2	21.7	67.2	69.4	70	70
									E24	24	2	28.9	76.2	78.4	80	80
									E36	34	2	40.9	91.3	93.5	100	100
									E54	54	2	65.0	91.3	93.5	100	100
	575	7.7	54.0	12.0	0.6	6.0	1.8	4.0	None	-	-	-	29.7	31.5	35	35
									E18	18	2	17.3	51.4	53.2	60	60
									E24	24	2	23.1	58.6	60.4	60	70
									E36	34	2	32.7	70.6	72.4	80	80
									E54	54	2	52.0	70.6	72.4	80	80

1. Minimum Circuit Ampacity.
2. Dual Element, Time Delay Type.
3. HACR type per NEC.

Typical Wiring Diagrams

J06 thru 12XP Typical Wiring Diagrams

Typical J06 thru 10XP Heat Pump with/without Electric Heat Wiring Diagram

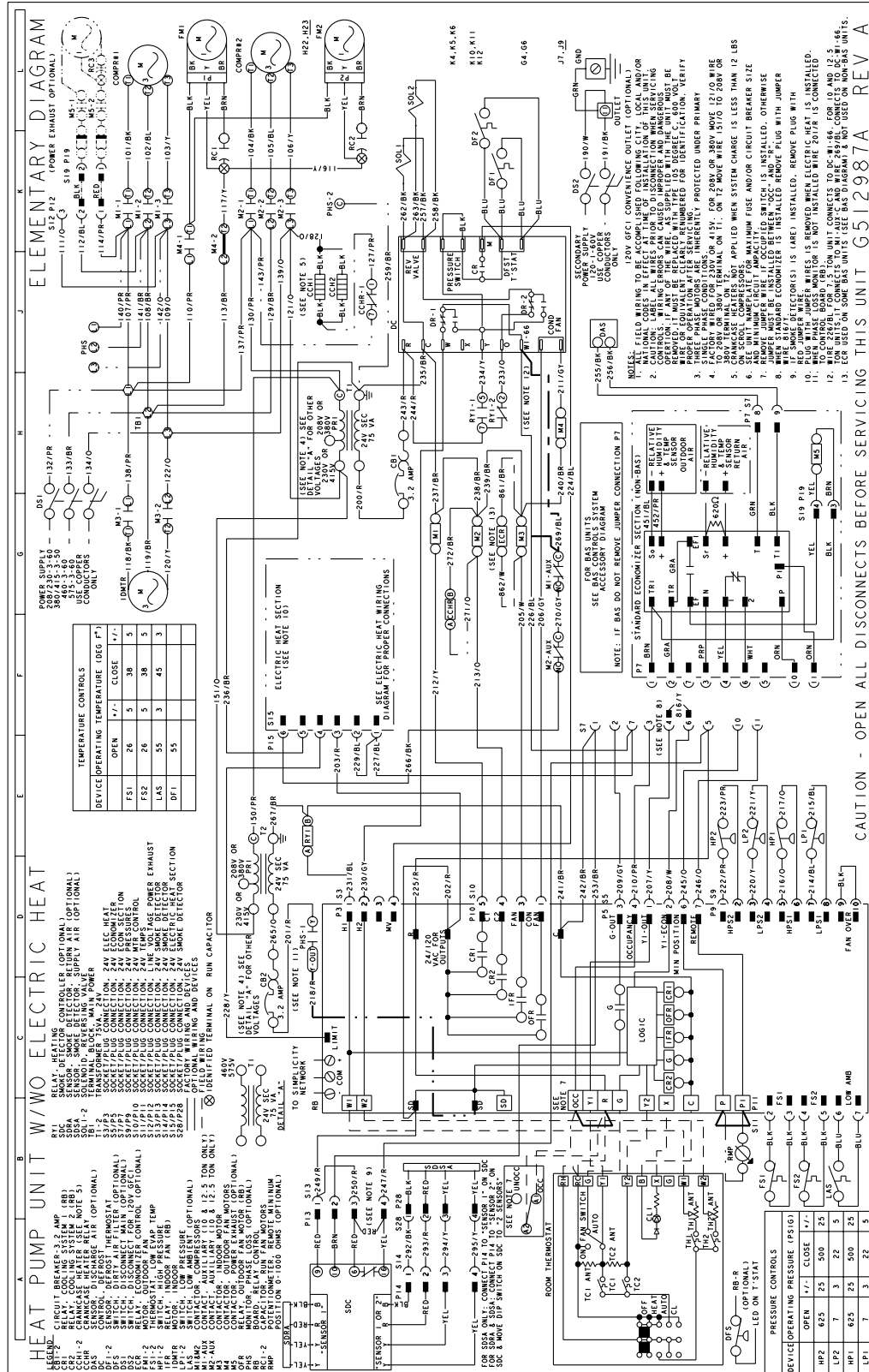

Typical J12XP Heat Pump with/without Electric Heat Wiring Diagram

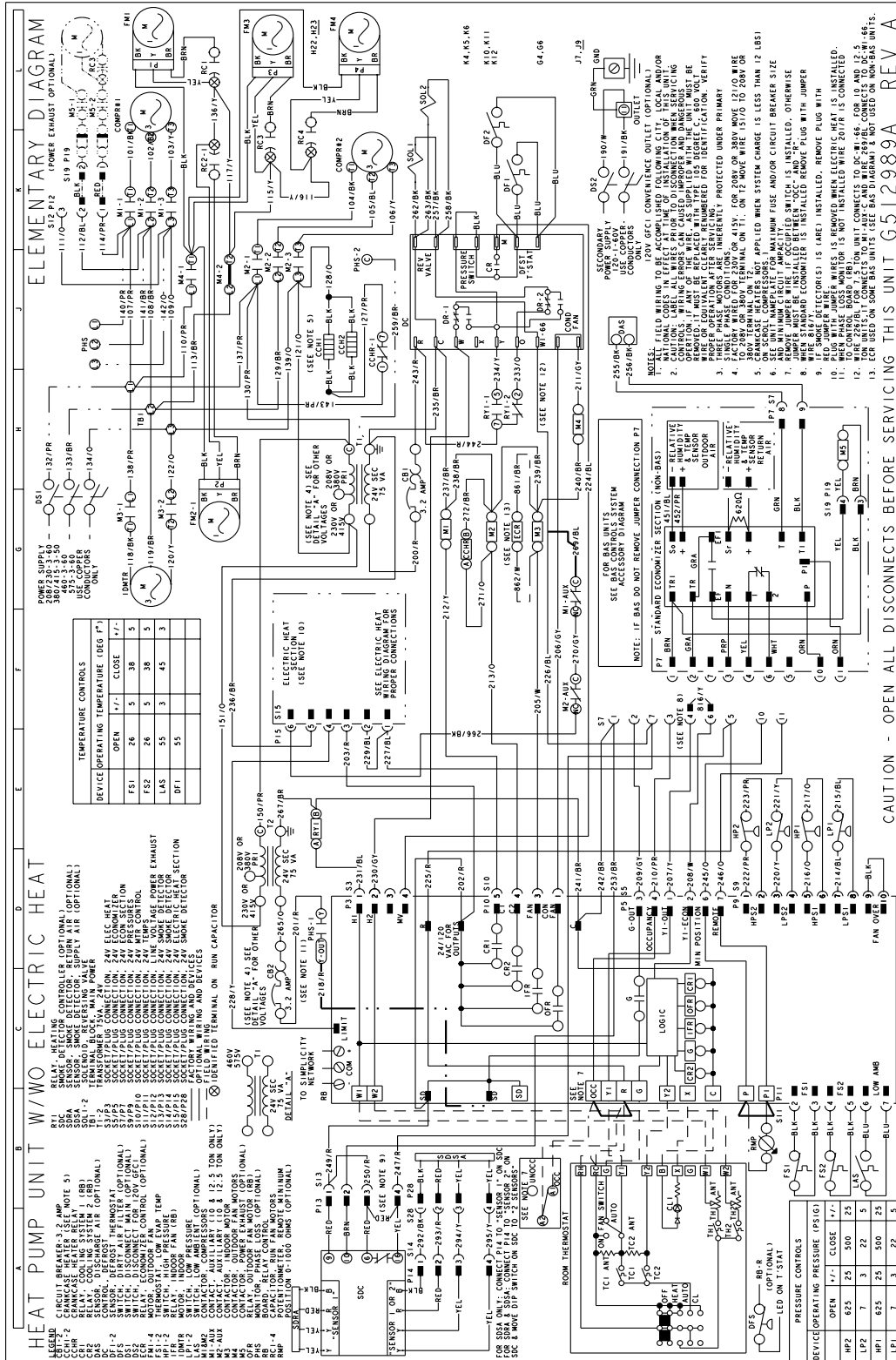

Weights and Dimensions

J06 thru 12XP Unit Weights

Unit 4 Point Load Weight

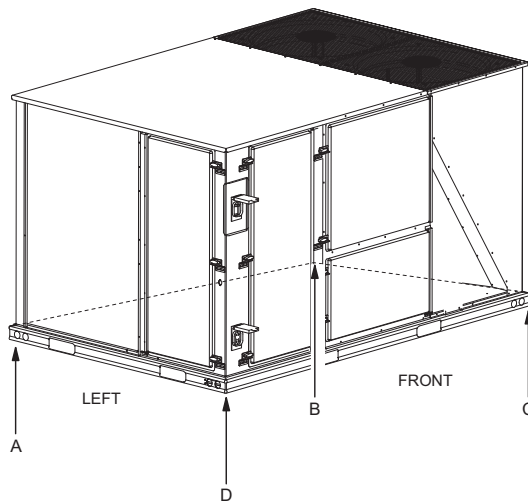

Unit 6 Point Load Weight

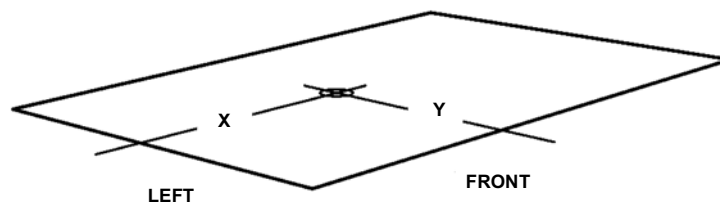
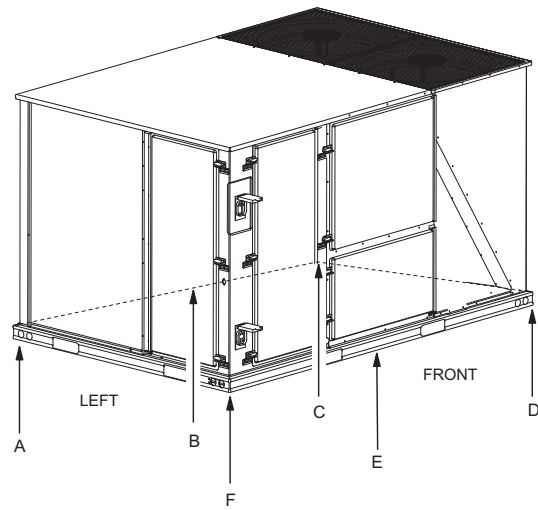

Size (Tons)	Model	Weight (lbs.)		Center of Gravity		4 Point Load Location (lbs.)				6 Point Load Location (lbs.)					
		Shipping	Operating	X	Y	A	B	C	D	A	B	C	D	E	F
J06 (6.5)	XP	1085	1080	38	25	262	195	266	357	184	150	124	169	204	250
J07 (7.5)	XP	1095	1090	38	23	243	181	284	381	171	139	115	181	217	267
J08 (8.5)	XP	1142	1137	38	25.5	282	210	276	370	197	161	133	175	211	259
J10 (10)	XP	1140	1135	38	25.5	281	209	275	369	197	160	133	175	211	259
J12 (12.5)	XP	1408	1403	51	25.5	259	347	456	340	165	198	244	320	260	216

J06 thru 12XP Unit Accessory Weights

Unit Accessory	Weight (lbs.)	
	Shipping	Operating
Economizer	90	85
Power Exhaust	40	35
Electric Heat ¹	49	49

1. Weight given is for the maximum heater size available (54KW).

J06 thru 12XP Unit Dimensions

J06 thru 10XP

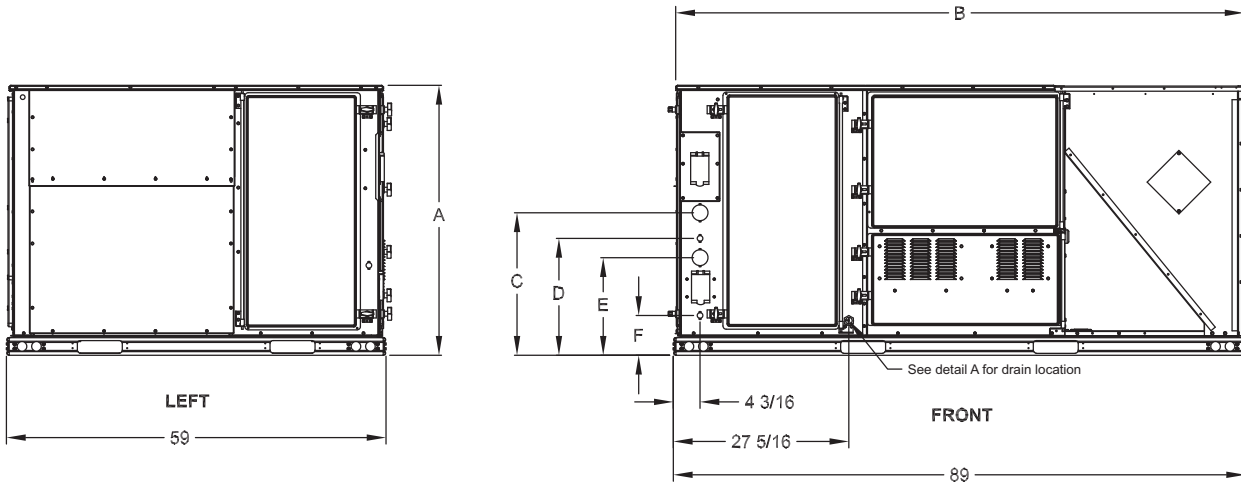

J12XP

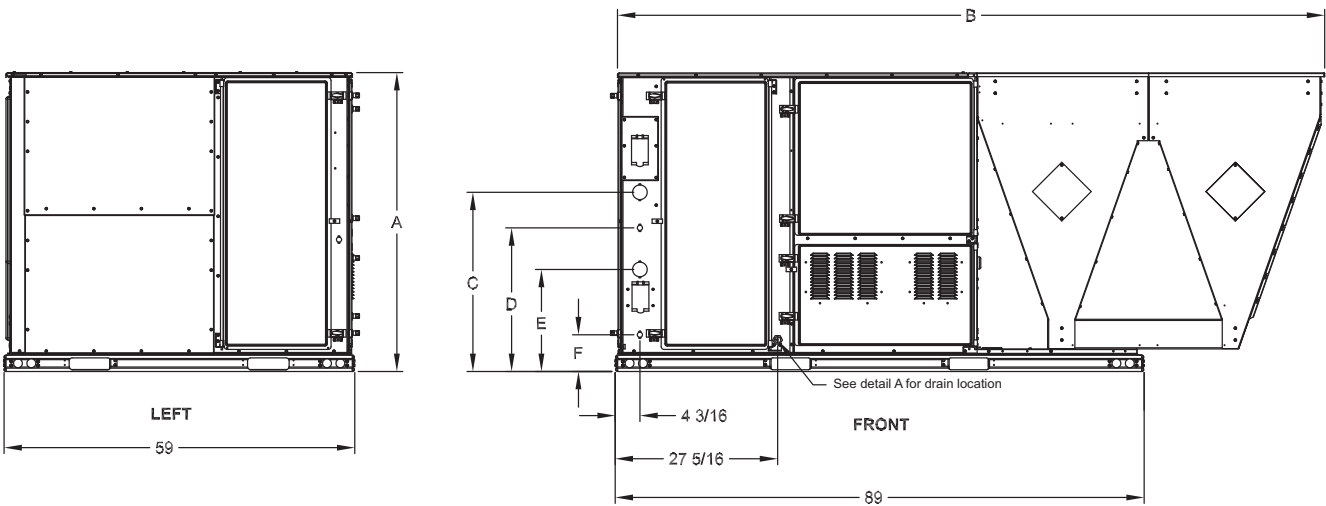

J06 thru 12XP Unit Physical Dimensions

Unit Model Number	Dimension (in.)					
	A	B	C	D	E	F
J06	50 3/4	89	30 3/16	24 3/16	17 3/16	6 3/16
J07	50 3/4	89	30 3/16	24 3/16	17 3/16	6 3/16
J08	50 3/4	89	30 3/16	24 3/16	17 3/16	6 3/16
J10	50 3/4	89	30 3/16	24 3/16	17 3/16	6 3/16
J12	50 3/4	119 1/2	30 3/16	24 3/16	17 3/16	6 3/16

Detail A

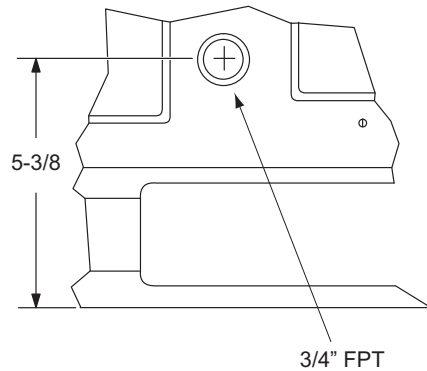

J06 thru 12XP Unit Clearances

Direction	Distance (in.)	Direction	Distance (in.)
Top ¹	72	Right	12
Front	36	Left	36
Rear	36	Bottom ²	0

- Units must be installed outdoors. Over hanging structure or shrubs should not obscure condenser air discharge outlet.
- Units may be installed on combustible floors made from wood or class A, B or C roof covering materials.

J06 thru 12XP Unit Bottom Duct Openings

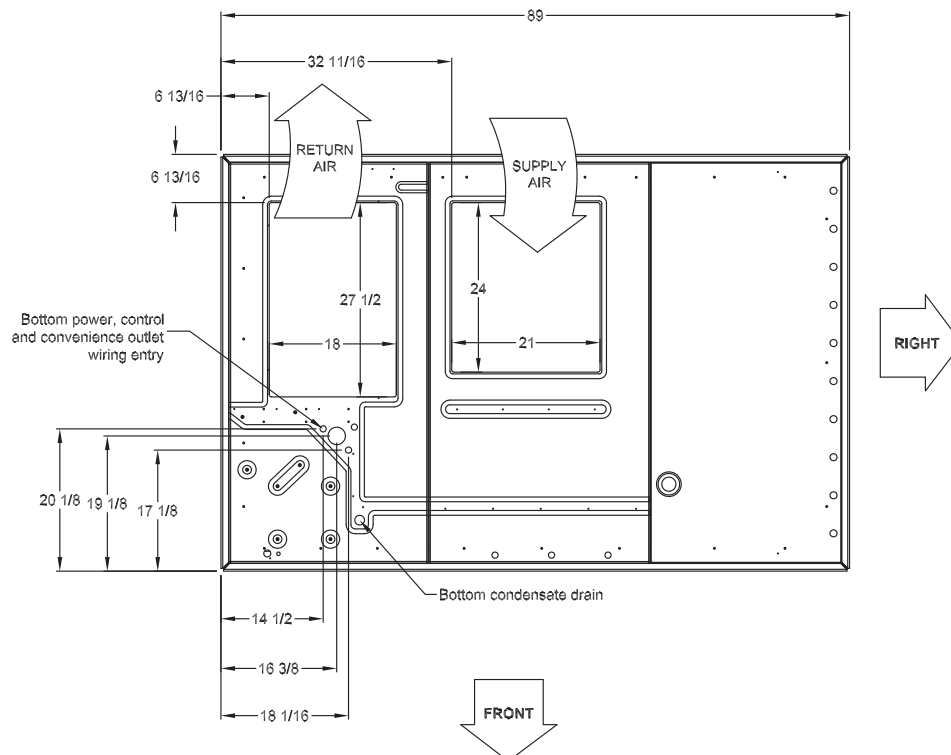

J06 thru 12XP Unit Electrical Entry

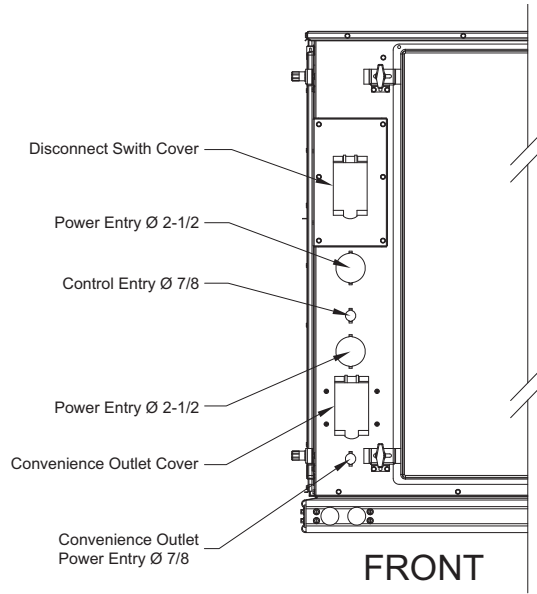

J06 thru 10XP Unit Side Duct Openings

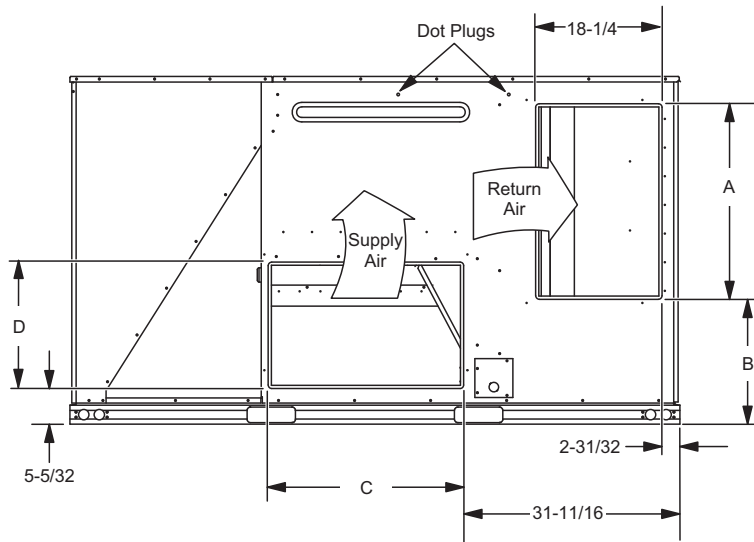

J12XP Unit Side Duct Openings

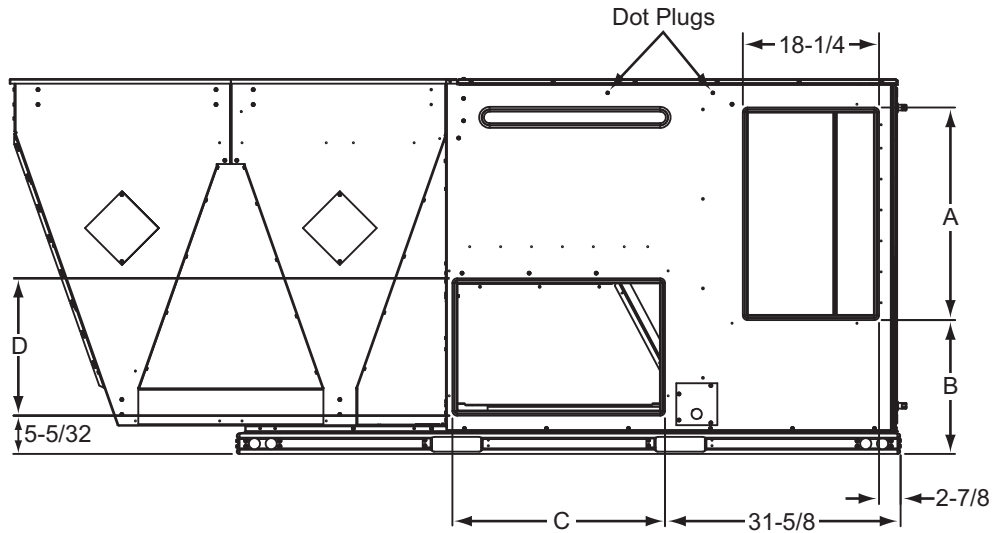

Side Duct Dimensions

Unit Model Number	Dimension (in.)			
	A	B	C	D
J06	28 1/4	18 1/16	28 1/4	18 1/4
J07	28 1/4	18 1/16	28 1/4	18 1/4
J08	28 1/4	18 1/16	28 1/4	18 1/4
J10	28 1/4	18 1/16	28 1/4	18 1/4
J12	28 1/4	18 1/16	28 1/4	18 1/4

J06 thru 12XP Unit Left Duct Opening

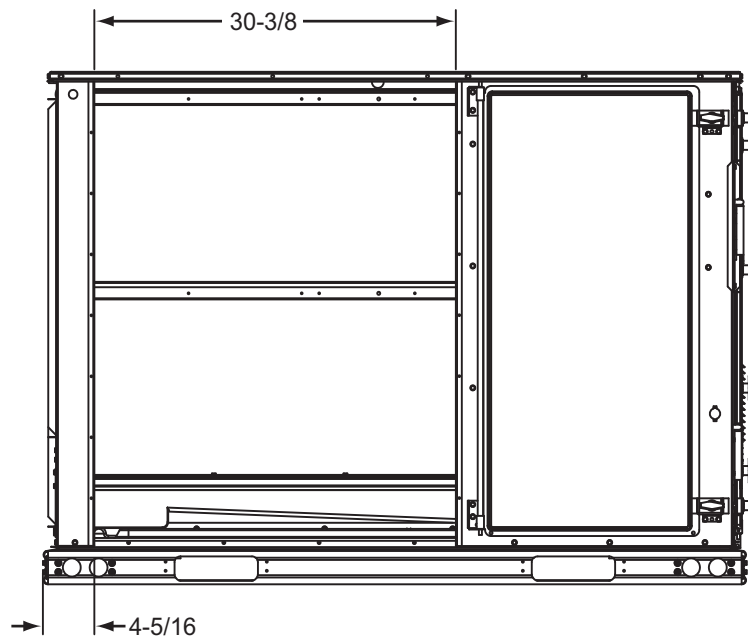

J06 thru 12XP Unit Accessory Dimensions

J06 thru 12XP Roof Curb

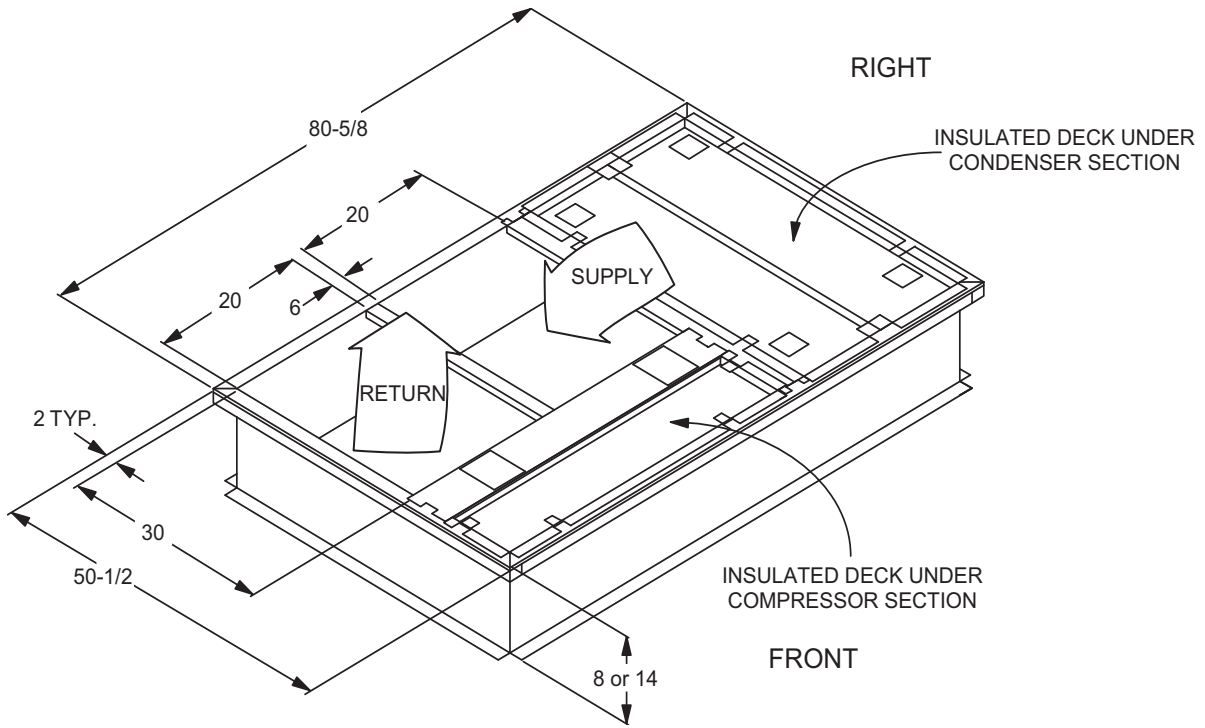

J06 thru 12XP Transition Roof Curb

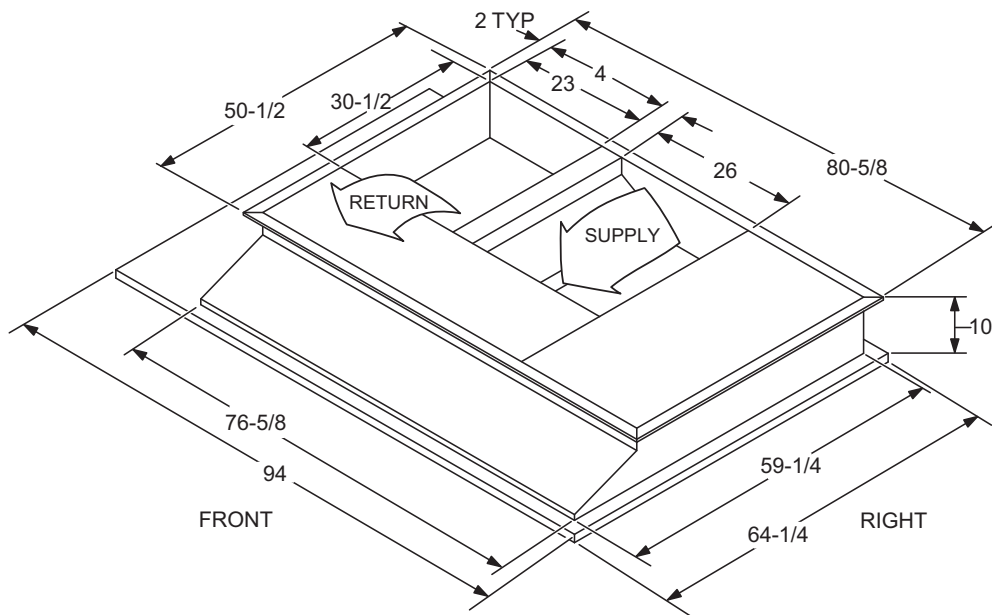

J06 thru 12XP Roof Curb Cut Away

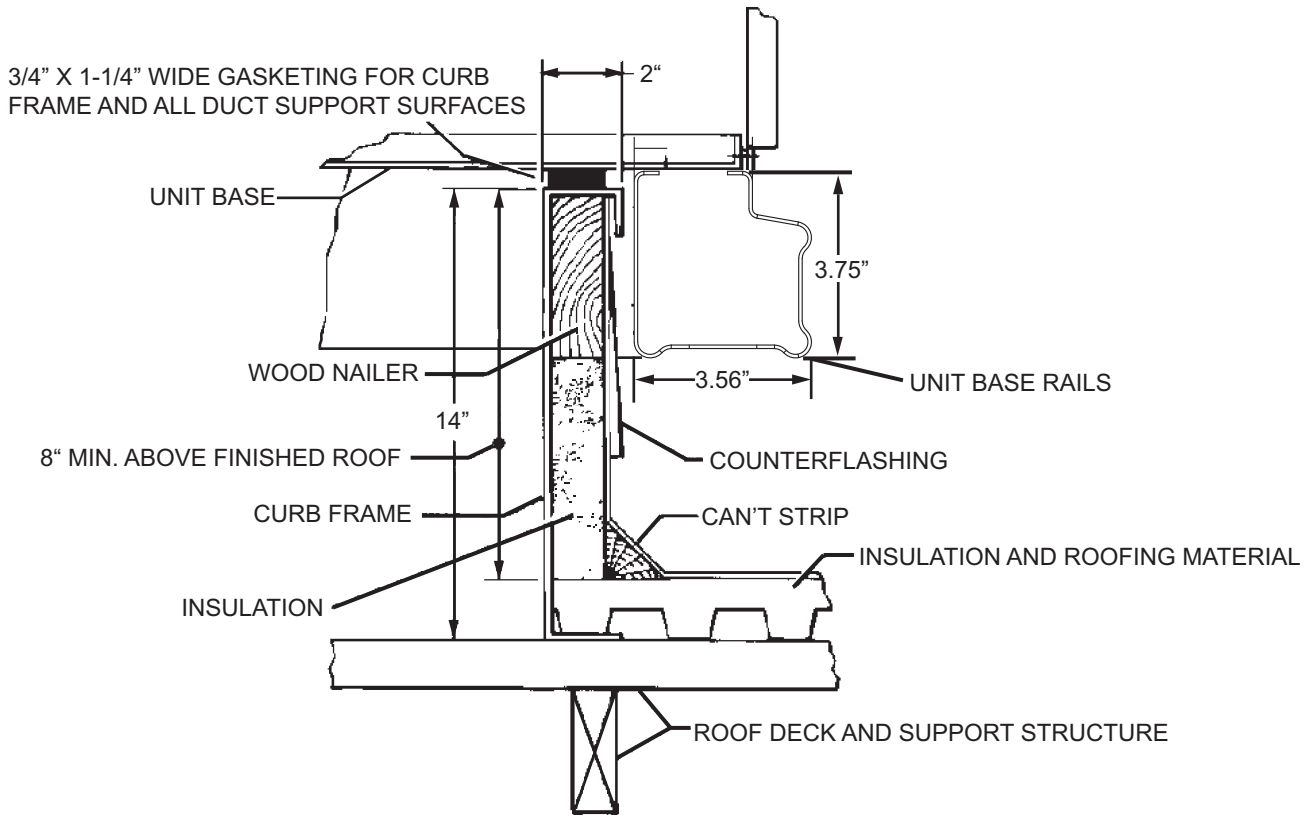

J06 thru 12XP Economizer Assembly

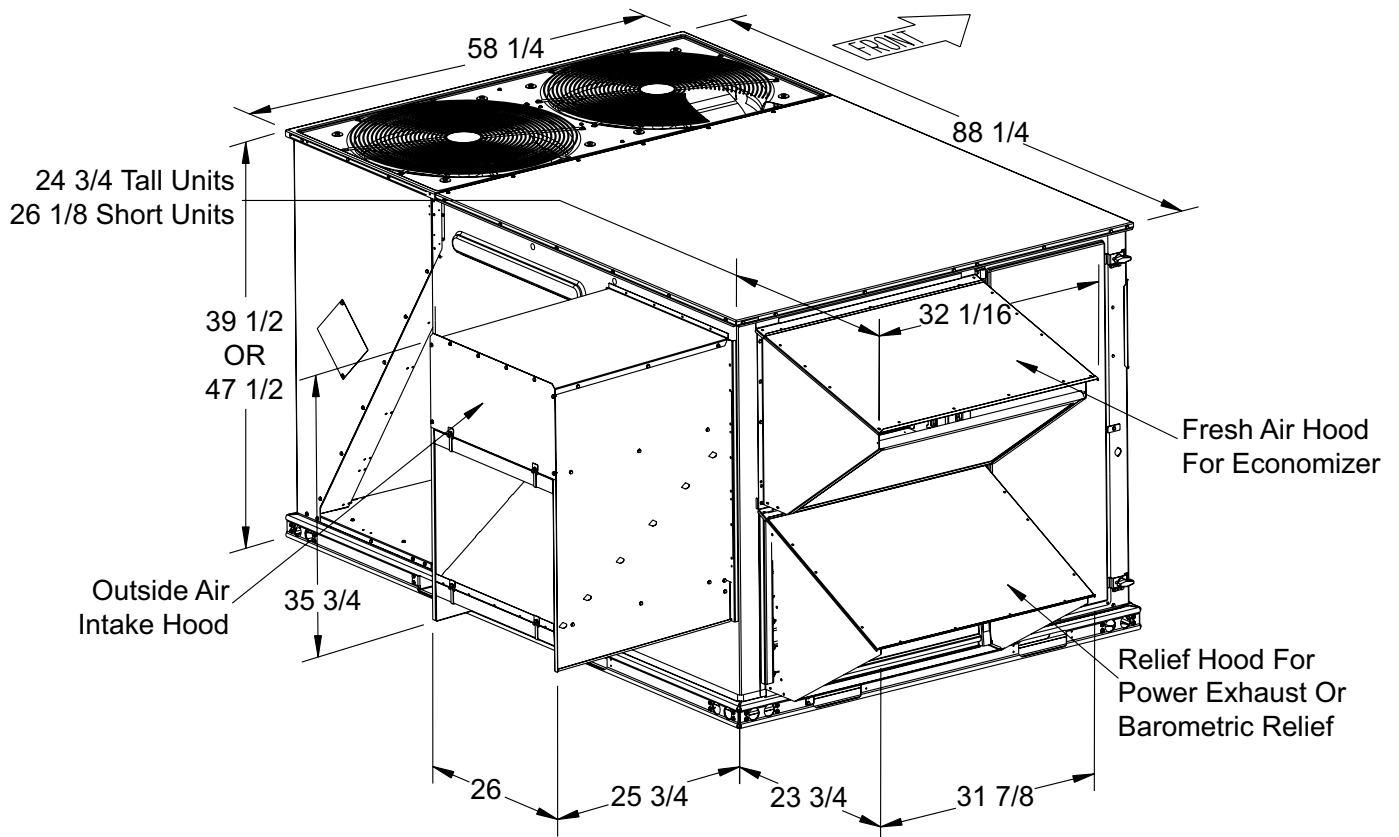

Economizer Options

Economizer Usage

Application	Cabinet Height	Description	Model
Side Return	All	Horizontal economizer without barometric relief	2EE04706024 ¹
ERV or End Return	42"	Slab Economizer, 42" tall cabinet	2EE04707524 ²
	50"	Slab Economizer, 50" tall cabinet	2EE04708324 ²

1. Barometric relief must be ordered separately and installed in duct work.
2. Barometric relief or fresh air hood not included. Must be ordered separately.

Field Installed Horizontal Economizer W/Power Exhaust

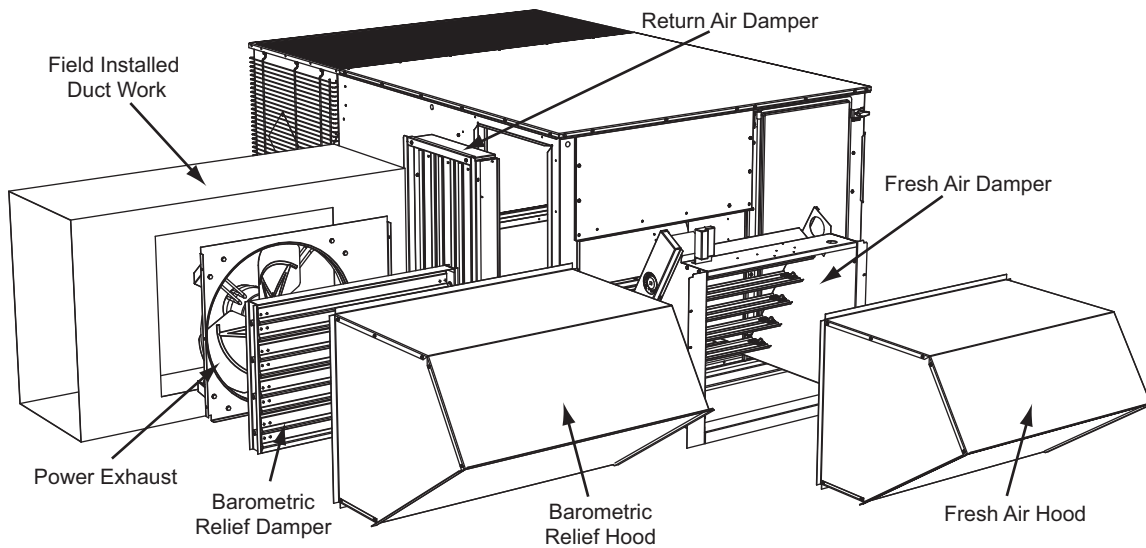

Slab Economizer Downflow W/Power Exhaust

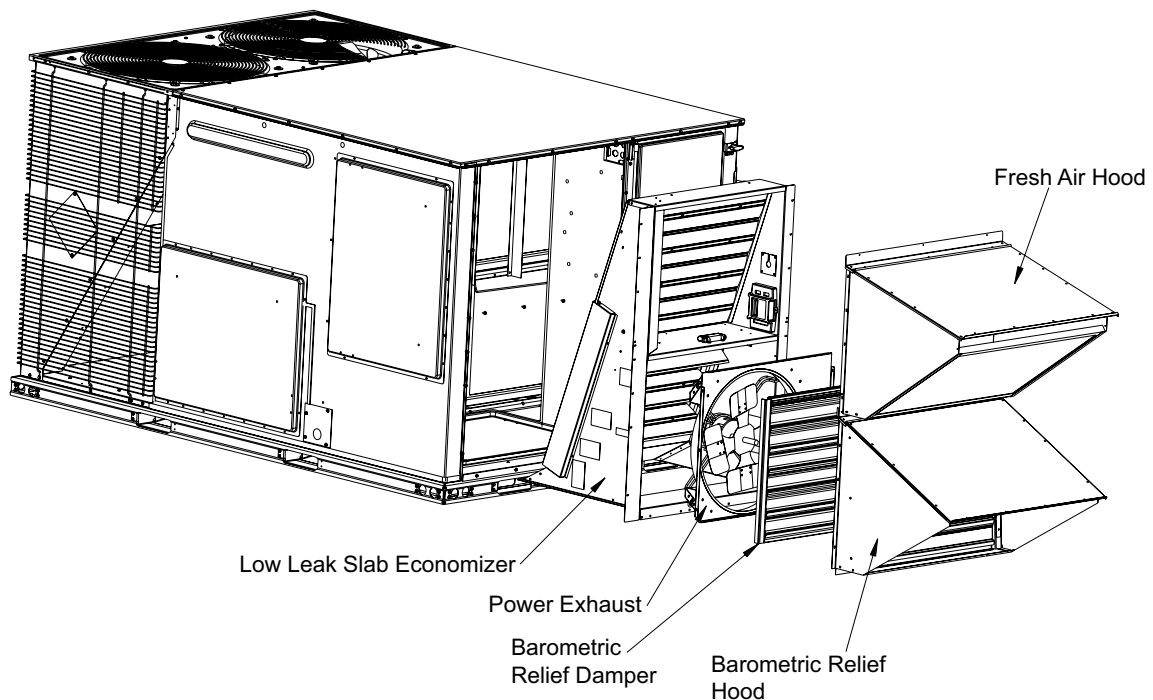

Slab Economizer End Return W/Power Exhaust

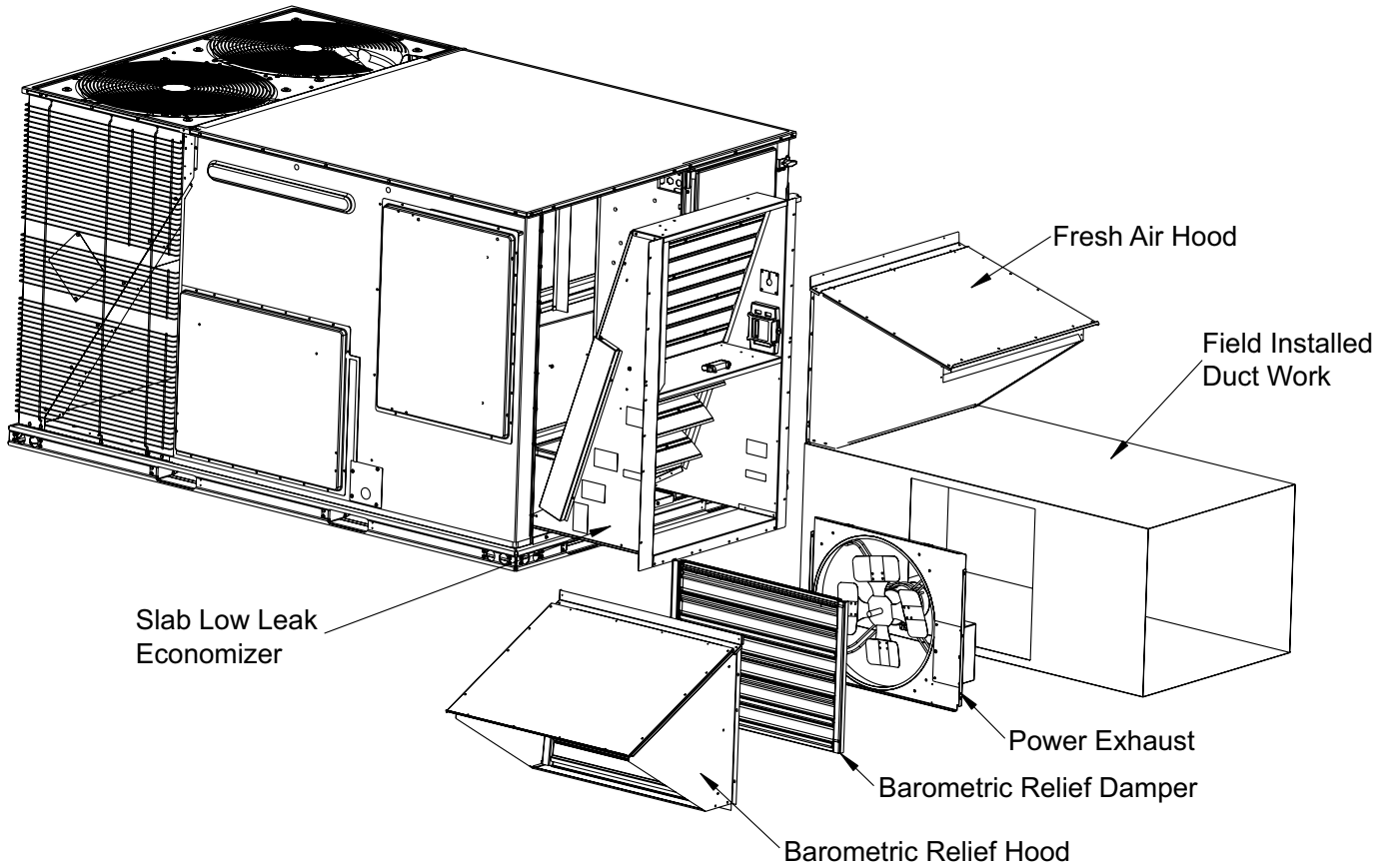

Subject to change without notice. Printed in U.S.A.
Copyright © 2014 by Johnson Controls, Inc. All rights reserved.

528461-JTG-K-0614
Supersedes: 528461-JTG-J-0513

York International Corporation
5005 York Drive
Norman, OK 73069