

**FOR SUBMITTAL
ONLY**

| NO. | ITEM | PART NUMBER | DESCRIPTION | QTY |
|-----|-----------------|------------------|--|-----|
| 1 | PUMP | HJ-4195 | VIKING - HEAVY DUTY - 21 GPM @ 25 PSIG - 1-1/2" NPT | 1 |
| 2 | MOTOR | 001158ET3E145T-S | WEG - 1.5 HP - 1800 RPM - TEFC - 145T FRAME - 3/60/460 | 1 |
| 3 | STRAINER | 53BTX | EATON - DUPLEX - 1-1/2" NPT | 1 |
| 4 | RELIEF VALVE | VJ-7R-SSWS | FULFLO - CI - SET @ 50 PSIG - 1-1/2" NPT | 1 |
| 5 | FILTER | RVFS-1 | RACOR - 2" NPT | - |
| 6 | CHECK VALVE | T-413Y | NIBCO - SWING TYPE - 1-1/2" NPT | 1 |
| 7 | FLOW SWITCH | V6EPB-B-S-6-B | DWYER - 1-1/2" | 1 |
| 8 | DISCHARGE GAUGE | 401L4PF | WGTC - 0-100 PSIG - 4" DIAL - 1/4" NPT | 2 |
| 9 | RBS SWITCH | L-170 | ISP | 1 |
| 10 | DP SWITCH | 1203PGS | ORANGE RESEARCH - 0-20 PSID | 1 |
| 11 | DP SWITCH | 1203PGS | ORANGE RESEARCH - 0-10 PSID | 1 |
| 12 | SUCTION GAUGE | 401L4P4 | WGTC - 30-0-30 PSIG - 4" DIAL - 1/4" NPT | 1 |
| 13 | CONTROL PANEL | | ISP FUEL SYSTEMS | 1 |
| 14 | BALL VALVE | 70-107-01 | APOLLO - BALL VALVE 1-1/2" NPT | |

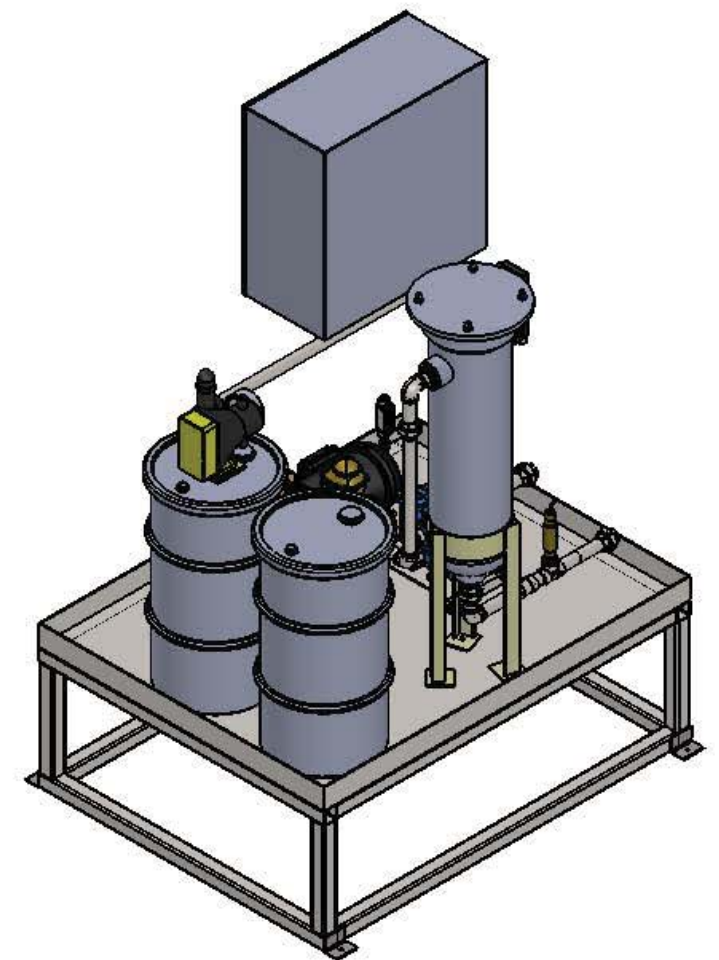
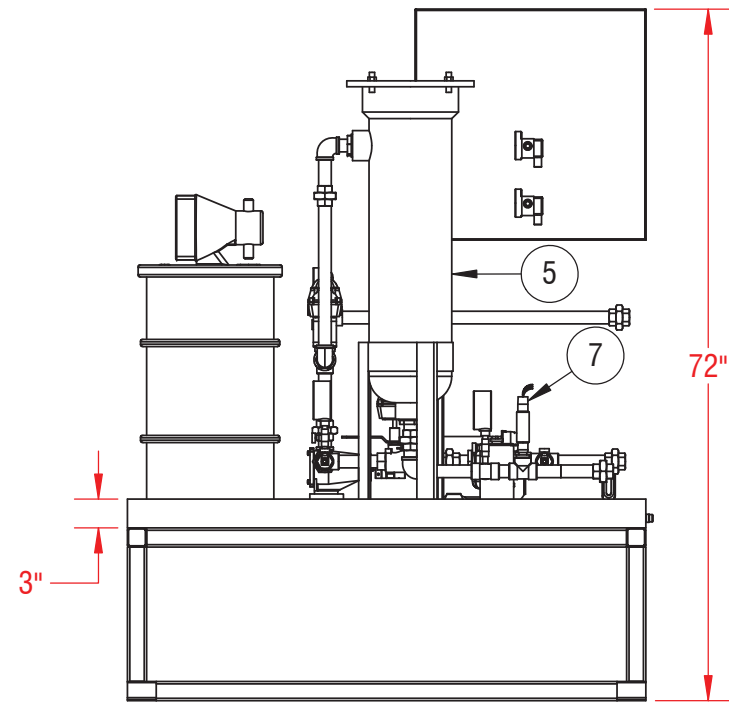
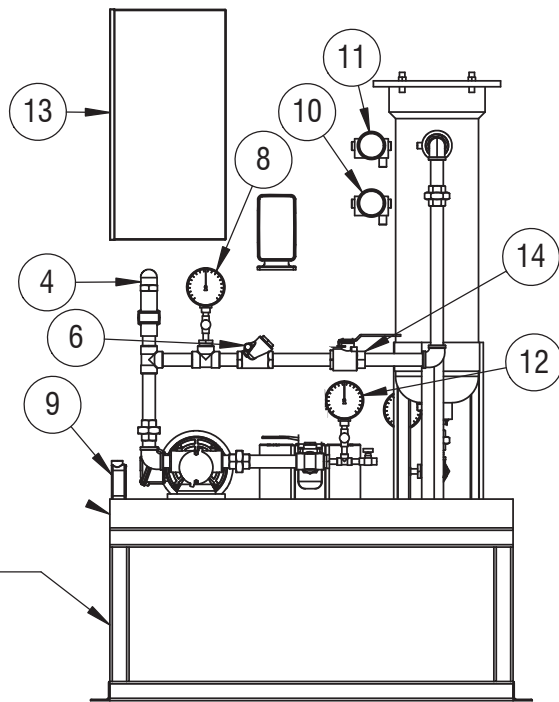

- NOTES:**
- WARNING:** DO NOT INSTALL ANY SHUT OFF DEVICES BETWEEN THE RETURN TO TANK CONNECTION AND THE TANK.
 - ALL PIPING IS SCHEDULE 40, CARBON STEEL.
 - ALL FITTINGS ARE 150#, THREADED.
 - SUPPORT STRUCTURE NOT SHOWN.
 - ASSEMBLE IN ACCORDANCE WITH PIPING SPECIFICATION PS-100; DIMENSIONS MAY VARY UP TO 1/8".

| | | | | |
|---|--------------------|-------------|------------------------|--------------------------------|
| DRAWN S.BECKETT (GW) | DATE 03/08/2016 | APPROVED BY | DATE | CUSTOMER |
| MATERIAL PER COMPONENT | FINISH | | SERVICE #2 FUEL OIL | |
| DRAWING TITLE/PROJECT FILTRATION SKID - SPF-13-3 | | | STATUS | SCALE |
| | | | JOB NO. 35-311 MWNT | SHEET 1 OF 1 |
| | | | SIZE B | DRAWING NUMBER 15-XXX-20-20 |
| | | | | REV. 1 |

