

Wire and Cable

Heat-shrink Tubing

Non-shrink Tubing

Braided Sleeving

Screening Braids

Moulded Parts

Terminals and Splices

**Wire and Cable Markers**

Accessories

Connectors

Backshells

Bonding Leads

Metal Braids

Relays and Contactors

Switches and Grips

Adhesives and Tapes

Application Equipment

Added Value Services

## INTRODUCTION

### Advanced Identification and Labelling Project Solutions

- Heat Shrinkable
- Tie-on Markers
- Adhesive Labels
- Hardware and Software
- Additional Ident Products

Identification and labelling products are increasingly important as the preferred method of identification and traceability, for harness wire and cable, control panel and components.

Our product range covers a multitude of styles and materials including heat-shrinkable markers, tie-on, wrap-around and self-adhesive labels that meet international UL, CSA & Mil-Spec specifications. Products can be marked using a range of state of the art thermal transfer printers.

Applications range from commercial component labelling through to high performance critical systems identification. Typical product performance characteristics include extreme temperature operation, zero halogen, low smoke, low toxicity, chemical resistance, abrasion resistant, electrical insulation, strain relief and UV resistance.



- Mechanical Protection
- Extreme Temperature Performance
- Chemical Resistance
- Fluid & Solvent Resistance
- Moisture protection
- Strain Relief, Flexibility
- Flame-Retardant, Low Smoke
- High Shrink Ratio
- Low shrink Temperature
- Aesthetic Enhancement
- Fast and Efficient Installation

<b>Heat Shrinkable Markers</b>	Selection Guide and Overview	page 286	1
TMS-SCE	Military Grade	page 288	
HT-SCE	High Temp, Low Out gassing	page 289	2
HX-SCE	Low Fire Hazard	page 290	
D-SCE	Fluid resistant	page 291	3
ZHD-SCE	LFH and Fluid resistant	page 292	
UV-SCE	UV resistant	page 293	4
RPS	Commercial Grade	page 294	
TMS-CCUV	UV Protection Sleeve	page 295	5
<b>Tie-on Markers</b>	Selection Guide	page 296	
CM-SCE-TP	Military Grade	page 297	6
HLX125	Low Fire Hazard	page 298	
PM316	Stainless Steel	page 299	7
<b>Adhesive Labels</b>	Selection Guide	page 300	
SBPlus	Self Laminating	page 301	8
PVF	Self laminating	page 302	
MP	Metallised Polyester	page 303	9
MV	Tamper Evident Metallised Polyester	page 304	
WP	White Polyester	page 305	10
TTP	Continuous Polyester	page 306	
RMK-A4	Epoxy Coated	page 307	11
<b>Hardware and Software</b>			
WinTotal	Software	page 308	12
T200 Ident	Printer	page 310	
TE3112	Printer	page 311	13
RIBBON	Thermal Transfer Ribbons	page 312	
<b>Additional Ident Products</b>			14
	Universal Payoff and Push-On Markers	page 314	
	Pre-Print Service	page 315	15
			16
			17
			18

# Wire and Cable Markers

## Heat Shrink Selection Chart

### Cable Identification Markers

#### Overview

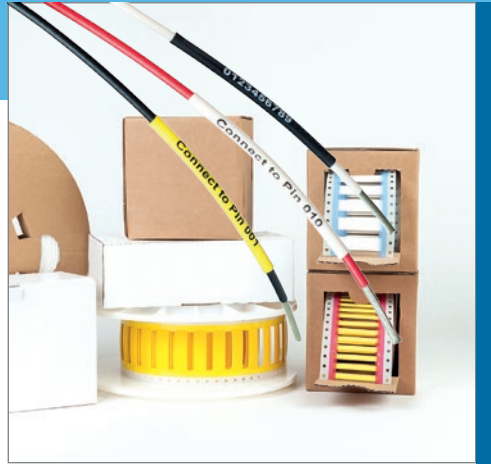

Our cable identification solutions provide a “marked” difference. Heat-shrinkable cable identification marker sleeves are available in a wide variety of configurations, colours and sizes for high performance applications such as military grade, low-fire hazard, fluid resistant, high temperature and commercial use.

Printable cable markers for large wire bundles, cables, pipes and conduits come in a variety of colours and sizes for military, high temperature, and low-fire hazard applications.

Product	UL Recognised	CSA Approved	SAE AS5942	SAE-AMS DTL-23053	SNCF NF F	EN 50343	Operating Temperature		Shrink Ratio	Thermal Printing	White	Yellow	Black	Clear	Non Standard Colours	Sleeve Pre-scored	Description
							Min.	Max.									
TMS-SCE	•	•	•	•			-55°C	135°C	3:1	•	•	•			•	•	MIL Spec
HT-SCE	•		•				-55°C	225°C	2:1	•	•		•			•	High temp. Low gas
HX-SCE			•		•	•	-30°C	105°C	2:1	•	•	•			•	•	Low fire hazard
D-SCE			•	•	•	•	-55°C	135°C	3:1	•	•	•			•	•	Fluid resistant
ZHD-SCE						•	-55°C	125°C	2:1	•	•	•			•	•	LFH & fluid resistant
UV-SCE	•						-55°C	200°C	2:1	•	•	•				•	UV & fire retardant
RPS	•	•	•				-30°C	105°C	3:1	•	•	•				•	Commercial
TMS-CCUV	•	•		•			-55°C	150°C	2:1					•			UV resistant, clear

Available on the range of heat shrinkable identification sleeves, in four standard lengths of 50mm, 25mm, 16mm and 12.5mm. Our in-house ability to score sleeves means we can offer a fast order turnaround.

- **S1** Scored sleeve for 2 x 25mm sleeves
- **S2** Scored sleeve for 3 x 16mm sleeves
- **S3** Scored sleeve for 4 x 12.5mm sleeves

For non-standard lengths please contact us.

Minimum order quantity is based on the pack size of the particular heat shrinkable sleeve.

Perforated score line is made to produce multiple markers from each sleeve. For part numbering add **S1**, **S2** or **S3** to end of the individual part number.

Illustration shows nominal actual size of a 3.2mm Ø marker, using an 11 point Arial font.

Un-scored sleeve



S1 Perforated sleeve for 2 x sleeves

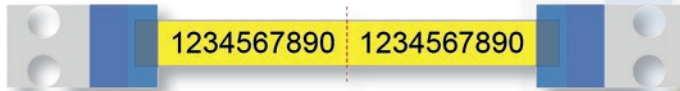

S2 Perforated sleeve for 3 x sleeves



S3 Perforated sleeve for 4 x sleeves

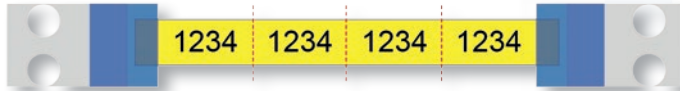

The above represents the standard choices, other options and variants are available, please contact us for information.

3/32	2.4	1
1/8	3.2	2
3/16	4.8	1
1/4	6.4	1
3/8	9.5	1
1/2	12	1
3/4	18	6

# Wire and Cable Markers

## TMS-SCE

Military Grade

Heat Shrink Identification Sleeves

3:1  
shrink



- 1 Military grade wire identification sleeve. Offering thin wall, flame retardant radiation cross linked modified heat shrinkable tubing.
- 2 Standard colours available are White or Yellow.

### Features & Benefits

- Lightweight for aerospace applications.
- CSA certified
- Available as pre-scored marker sleeves

### Operating Temperature Range

- -55°C to +135°C

### Installation

- Minimum recovery temperature +85°C
- Maximum storage temperature +40°C

Recommended printers:

T200-IDENT-PRINTER and the TE3112.

Approved ribbon:

TMS-RJS-RIBBON-4RPSCE

### Specifications and Approvals

- SAE AS5942 (print adherence)
- MIL-STD-202 method 215 (solvent resistance)
- SAE-AMS-DTL-23053/5 class 1
- EN45545-2 R24 HL2
- UL STD 224 (File 35586)
- CSA Certified (file 31929)
- NSA 937201 Type MR & MT
- BMS 13-69 Grade A & B

Ordering Description	Supplied Ø mm	Recovered Ø mm	Recommended Range mm	Weight g/10 pcs	Pack Size
TMS-SCE-3/32-2.0-Colour	2.36	0.79	0.81 - 1.90	1.50	250 pcs
TMS-SCE-1/8-2.0-Colour	3.18	1.07	1.11 - 2.66	2.03	250 pcs
TMS-SCE-3/16-2.0-Colour	4.75	1.57	1.75 - 4.06	2.68	250 pcs
TMS-SCE-1/4-2.0-Colour	6.35	2.11	2.31 - 5.46	3.51	250 pcs
TMS-SCE-3/8-2.0-Colour	9.53	3.18	3.47 - 8.12	5.04	250 pcs
TMS-SCE-1/2-2.0-Colour	12.70	4.22	4.64 - 10.79	6.81	250 pcs
TMS-SCE-3/4-2.0-Colour	19.05	6.35	6.99 - 16.25	12.03	250 pcs
TMS-SCE-1-2.0-Colour	25.40	8.46	9.29 - 21.59	15.35	250 pcs
TMS-SCE-1-1/2-2.0-Colour*	38.10	19.05	20.95 - 33.02	27.51	250 pcs
TMS-SCE-2-2.0-Colour*	50.80	25.40	27.94 - 44.95	47.27	250 pcs
TMS-SCE-2-1/4-2.0-Colour	57.15	19.05	22.32 - 50.80	42.06	250 pcs

Alternative packaging sizes also available please ask for details

\* Please note that shrink ratio is 2:1

### Standard Colours Available



For non standard colours please contact us for details and MOQ's.

## HT-SCE

High Temperature and Low Out-gassing  
Heat Shrink Identification Sleeves

2:1  
shrink



High temperature low out-gassing heat shrinkable wire identification sleeves. Designed for use in high temperature applications or where extreme resistance to fuels, lubricants and cleaning solvents is required.

### Features & Benefits

- High continuous operating temperature.
- Extreme fluid resistance.
- Low vacuum out-gassing.
- Available as pre-scored marker sleeves

### Operating Temperature Range

- -55°C to +225°C

### Installation

- Minimum recovery temperature +200°C
- Maximum storage temperature +40°C

Recommended printers:

**T200-IDENT-PRINTER** and the **TE3112**.

Approved ribbon:

**TMS-RJS-RIBBON-4HT**

If black tubing **TMS-RJS-RIBBON-WHT-4HT**

### Specifications and Approvals

- SAE AS5942 (print adherence)
- MIL-STD-202G method 215 (solvent resistance)
- UL-224 VW-1 rated
- Low out-gassing 1% max TML, 0.1% max VCM
- NSA 937201 Type MK & ML
- BMS 13-69 Grade C & D

Ordering Description	Supplied Ø mm	Recovered Ø mm	Recommended Range mm	Pack Size
HT-SCE-3/32-2.0-Colour	2.36	0.79	0.81 - 1.90	250 pcs
HT-SCE-1/8-2.0-Colour	3.17	1.57	1.75 - 2.66	250 pcs
HT-SCE-3/16-2.0-Colour	4.74	2.36	2.54 - 4.06	250 pcs
HT-SCE-1/4-2.0-Colour	6.35	3.18	3.40 - 6.00	250 pcs
HT-SCE-3/8-2.0-Colour	9.52	4.74	5.30 - 8.10	250 pcs
HT-SCE-1/2-2.0-Colour	12.70	6.35	6.60 - 11.40	250 pcs
HT-SCE-3/4-2.0-Colour	19.05	9.53	9.90 - 15.30	250 pcs
HT-SCE-1-2.0-Colour	25.40	12.70	13.30 - 23.00	250 pcs
HT-SCE-1-1/2-2.0-Colour	38.10	19.05	20.95 - 34.00	250 pcs

Alternative packaging sizes also available please ask for details.

### Standard Colours Available



9

White

0

Black

For non standard colours please contact us for details and MOQ's.

# Wire and Cable Markers

## HX-SCE

Low Fire Hazard  
Heat Shrink Identification Sleeves



1 Ideal for applications where limited fire hazard characteristics are necessary. The zero halogen material coupled with low smoke and low toxic fume emissions make the product ideal for use in enclosed spaces such as mass transit, marine and industrial installations.

### Features & Benefits

- Meets international rail LFH standards.
- High performance print quality.
- Available as pre-scored marker sleeves.

### Operating Temperature Range

- -55°C to +105°C

### Installation

- Minimum recovery temperature +120°C
- Maximum storage temperature +40°C

Recommended printers:

**T200-IDENT-PRINTER** and the **TE3112**.

Approved ribbon:

**1966-RIBBON**

### Specifications and Approvals

- SAE AS5942 (print adherence)
- MIL-STD-202G method 215 (solvent resistance)
- EN45545-2 R22/R23/R24 HL3
- LUL 1-085 A3 (Fire Safety Performance)
- NF F 16-101 (Class 1A)
- BS 6853 Cat 1A
- EN 50343 H (Diesel immersion removed)

Ordering Description	Supplied Ø mm	Recovered Ø mm	Recommended Range mm	Pack Size
<b>HX-SCE-2.4-50-Colour</b>	2.36	1.19	1.27 - 1.90	250 pcs
<b>HX-SCE-3.2-50-Colour</b>	3.17	1.58	1.77 - 2.66	250 pcs
<b>HX-SCE-4.8-50-Colour</b>	4.74	2.36	2.54- 4.06	250 pcs
<b>HX-SCE-6.4-50-Colour</b>	6.35	3.18	3.81 - 5.46	250 pcs
<b>HX-SCE-9.5-50-Colour</b>	9.52	4.75	5.59 - 8.12	250 pcs
<b>HX-SCE-12.7-50-Colour</b>	12.70	6.35	6.99- 10.79	250 pcs
<b>HX-SCE-19-50-Colour</b>	19.05	9.53	10.16 - 16.25	250 pcs
<b>HX-SCE-25.4-50-Colour</b>	25.40	12.70	14.29 - 21.59	250 pcs
<b>HX-SCE-38.1-50-Colour</b>	38.10	19.05	20.95 - 33.02	250 pcs

Alternative packaging sizes also available please ask for details

### Standard Colours Available



For non standard colours please contact us for details and MOQ's.



## D-SCE

### Fluid Resistant Heat Shrink Identification Sleeves

3:1 shrink



Suitable for applications where exposure to organic fluids, especially oils, is required. Designed to operate in these conditions at elevated temperatures for extended periods, making them ideal for rail and construction industries.

#### Features & Benefits

- Resistance to organic fluids, common fuels, lubricants and solvents.
- Available as pre-scored marker sleeves.

#### Operating Temperature Range

- -75°C to +135°C

#### Installation

- Minimum recovery temperature +135°C
- Maximum storage temperature +40°C

Recommended printers:

**T200-IDENT-PRINTER** and the **TE3112**.

Approved ribbon:

**1966-RIBBON**

#### Specifications and Approvals

- AMS AS5942 4.1 (print adherence)
- MIL-STD-202G method 215 (solvent resistance)
- SAE AMS DTL 23053/6 Class 1
- EN50343 appendix H
- SNCF NF F 00608 (cat. A & H)

Ordering Description	Supplied Ø mm	Recovered Ø mm	Recommended Range mm	Pack Size
D-SCE-2.4-50-Colour	2.36	0.79	0.81 - 1.90	250 pcs
D-SCE-3.2-50-Colour	3.17	1.07	1.11 - 2.66	250 pcs
D-SCE-4.8-50-Colour	4.74	1.57	1.75 - 4.06	250 pcs
D-SCE-6.4-50-Colour	6.35	2.11	2.31- 5.46	250 pcs
D-SCE-9.5-50-Colour	9.52	3.18	3.47 - 8.12	250 pcs
D-SCE-12-50-Colour	12.70	4.22	4.64 - 10.79	250 pcs
D-SCE-18-50-Colour	19.05	6.35	6.99 - 16.25	250 pcs
D-SCE-25-50-Colour	25.40	8.46	9.29 - 12.59	250 pcs
D-SCE-38-50-Colour*	38.10	19.05	20.95 - 33.02	250 pcs

Alternative packaging sizes also available please ask for details

\* Please note that shrink ratio is 2:1

#### Standard Colours Available



9  
White

4  
Yellow

For non standard colours please contact us for details and MOQ's.

# Wire and Cable Markers

## ZHD-SCE

Halogen Free and Fluid Resistance  
Heat Shrink Identification Sleeves



1 Manufactured using a specially developed radiation cross-linked, zero halogen material. Designed specifically to bridge the gap for installations where the highest performance is demanded from an identification sleeve.

### Features & Benefits

- Meets international rail LFH standards
- No Halogens, Sulphur and Nitrogen
- Non-flame propagating
- High performance print quality.
- Available as pre-scored marker sleeves.

### Operating Temperature Range

- -55°C to +135°C

### Installation

- Minimum recovery temperature +120°C
- Maximum storage temperature +40°C

8 Recommended printers:  
**T200-IDENT-PRINTER** and the **TE3112**.

9 Approved ribbon:  
**1966-RIBBON**

### Specifications and Approvals

- SAE AS5942 (print adherence)
- MIL-STD-202G method 215 (solvent resistance)
- EN45545-2 R22 HL2
- BS 6853 Cat II
- EN 50343 (Appendix H)

Ordering Description	Supplied Ø mm	Recovered Ø mm	Recommended Range mm	Pack Size
ZHD-SCE-2.4-50-Colour	2.4	1.19	1.27 - 1.90	250 pcs
ZHD-SCE-3.2-50-Colour	3.2	1.58	1.77 - 2.66	250 pcs
ZHD-SCE-4.8-50-Colour	4.8	2.36	2.54- 4.06	250 pcs
ZHD-SCE-6.4-50-Colour	6.4	3.18	3.81 - 5.46	250 pcs
ZHD-SCE-9.5-50-Colour	9.5	4.75	5.59 - 8.12	250 pcs
ZHD-SCE-12.7-50-Colour	12.7	6.35	6.99- 10.79	250 pcs
ZHD-SCE-19-50-Colour	19.0	9.53	10.16 - 16.25	250 pcs
ZHD-SCE-25.4-50-Colour	25.4	12.70	14.29 - 21.59	250 pcs
ZHD-SCE-38.1-50-Colour	38.1	19.05	20.95 - 33.02	250 pcs

15 Alternative packaging sizes also available please ask for details

### Standard Colours Available

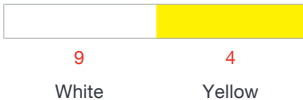

For non standard colours please contact us for details and MOQ's.

## UV-SCE

UV Resistant, Flame Retardant  
Heat Shrink Identification Sleeves

2:1\*  
shrink

UV  
PROTECT

RoHS  
compliant

The solution to identify wires and cables where extreme resistance to Ultra Violet (UV) and harsh weather conditions are required. UV-SCE offers outstanding physical performance, mark permanence and excellent legibility after 25,000 hours of UV and moisture exposure, without degradation.

### Features & Benefits

- UV Resistant
- Flame retardant polymer compound
- Available as pre-scored marker sleeves.

### Operating Temperature Range

- -55°C to +200°C

### Installation

- Minimum recovery temperature +135°C
- Maximum storage temperature +40°C

Recommended printers:

**T200-IDENT-PRINTER** and the **TE3112**.

Approved ribbon:

**T300-UV-SCE-RIBBON**

### Specifications and Approvals

- SAE AS5942 (print adherence)
- MIL-STD-202G method 215 (solvent resistance)
- EN45545-2 Class 3 R24
- IEC 60068-2, -5, procedure B
- NFT 46-019 method A
- BS EN 60068-2-5 B

Ordering Description	ID Supplied	ID Recovered	Recommended Range	Pack Size
UV-SCE-3/32-2.0-Colour	2.4	0.79	0.81 - 1.90	250 pcs
UV-SCE-1/8-2.0-Colour	3.2	1.58	1.75 - 2.66	250 pcs
UV-SCE-3/16-2.0-Colour	4.8	2.36	2.54 - 4.06	250 pcs
UV-SCE-1/4-2.0-Colour	6.4	3.18	3.40 - 6.00	250 pcs
UV-SCE-3/8-2.0-Colour	9.5	4.75	5.30 - 8.10	250 pcs
UV-SCE-1/2-2.0-Colour	12.7	6.35	6.60 - 11.40	250 pcs
UV-SCE-3/4-2.0-Colour	19.0	9.53	9.90 - 15.30	250 pcs
UV-SCE-1-2.0-Colour	25.4	12.70	13.30 - 23.00	250 pcs
UV-SCE-1-1/2-2.0-Colour	38.1	19.05	20.95 - 34.00	250 pcs

Alternative packaging sizes also available please ask for details

### Standard Colours Available



9

White

4

Yellow

For non standard colours please contact us for details and MOQ's.

# Wire and Cable Markers

## RPS

Commercial Grade  
Heat Shrink Identification Sleeves

3:1  
shrink



1 RPS markers are heat-shrinkable marker sleeves for general industrial applications, whilst resistant to abrasion, aggressive cleaning solvents and industrial fluids.

### Features & Benefits

- Flame retardant
- Available as pre-scored marker sleeves.

### Operating Temperature Range

- -30°C to +105°C

### Installation

- Minimum recovery temperature +120°C
- Maximum storage temperature +40°C

Recommended printers:

**T200-IDENT-PRINTER** and the **TE3112**.

Approved ribbon:

**TMS-RJS-RIBBON-4RPSCE**

### Specifications and Approvals

- SAE AS 81531 4.6.2 (print adherence)
- MIL-STD-202 method 215J (solvent resistance)
- UL 224 (file E35586)
- CSA Certified (file 31929)

Ordering Description	Supplied Ø mm	Recovered Ø mm	Recommended Range mm	Pack Size
RPS-22-18/2.0-Colour	3.18	1.07	1.17 - 2.66	250 pcs
RPS-18-12/2.0-Colour	4.75	1.57	1.75 - 4.06	250 pcs
RPS-16-10/2.0-Colour	6.35	2.11	2.31 - 5.46	250 pcs
RPS-8-4/2.0-Colour	9.53	3.18	3.47 - 8.12	250 pcs
RPS-10-2/2.0-Colour	12.70	4.22	4.64 - 10.79	250 pcs
RPS-6-250/2.0-Colour	19.05	6.35	6.99 - 16.25	250 pcs
RPS-1-400/2.0-Colour	25.40	8.46	9.29 - 21.59	250 pcs
RPS-400-1000/2.0-Colour*	38.10	19.05	20.95 - 3.02	250 pcs

Alternative packaging sizes also available please ask for details

\* Please note that shrink ratio is 2:1

### Standard Colours Available



For non standard colours please contact us for details and MOQ's.

## TMS-CCUV

Military Grade, UV Protection  
Cut Piece Clear Heat Shrink Sleeves

2:1  
shrink

UV  
PROTECT

RoHS  
compliant

Designed to provide increased protection for identification products in outdoor applications. The clear heat-shrinkable sleeves provide a barrier to the effects of ultraviolet (UV) radiation and tough resistance to abrasion and fluids.

Standard colour Clear only.

### Features & Benefits

- Added UV protection
- Resistance to abrasion and fluids

### Operating Temperature Range

- -55°C to +150°C

### Installation

- Minimum recovery temperature +150°C
- Maximum storage temperature +40°C

### Specifications and Approvals

- UL VW-1 rated
- SAE AMS DTL 23053/18, Class 2

Ordering Description	Supplied Ø mm	Recovered Ø mm	Length mm	Recommended Range mm	Pack Size
TMS-CCUV-SLEEVE-1	3.2	1.6	65	1.80 - 2.80	250 pcs
TMS-CCUV-SLEEVE-2	4.8	2.4	65	2.60 - 3.70	250 pcs
TMS-CCUV-SLEEVE-3	6.4	3.2	65	3.50 - 5.10	250 pcs
TMS-CCUV-SLEEVE-4	9.5	4.8	65	5.00 - 7.00	250 pcs
TMS-CCUV-SLEEVE-5	12.7	6.4	65	6.90 - 10.60	250 pcs
TMS-CCUV-SLEEVE-6	19.0	9.5	65	10.00 - 14.00	250 pcs
TMS-CCUV-SLEEVE-7	25.4	12.7	65	13.30 - 21.00	250 pcs
TMS-CCUV-SLEEVE-8	38.0	19.0	65	21.00 - 33.80	250 pcs

Also available in 32mm and 76mm lengths, in selected sizes, please ask for details

# Wire and Cable Markers

## Tie-On Selection Chart

### Cable Identification Markers Overview

1 Tie-On Cable markers are flat, non-adhesive labels that can be used to identify large cables and wire bundles in particularly aggressive environment.

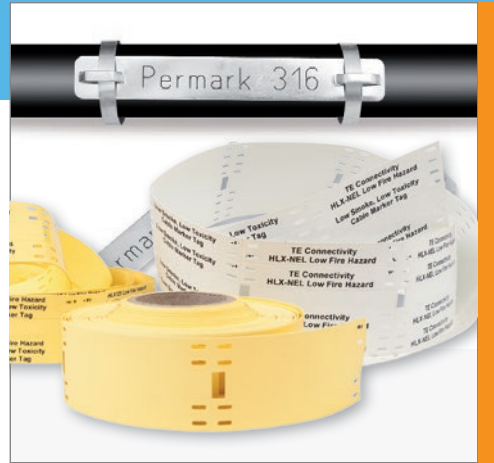

Product	SAE AS 81531 SAE-AMS DTL-23053		EN45545-2	Operating Temperature	Size (mm)	Thermal Print			Standard Colours	Non Standard Colours.	Description
						Metal	White	Yellow			
CM-SCE-TP	•		•	-55°C to +135°C	10.4 and 51.5	•		•	•	•	Polyolefin
HLX125	•	•		-40°C to +105°C	80 x 12.5	•		•	•	•	Zero halogen
PM316				-80°C to +500°C	95 x 12	n/a	•				Stainless Steel

## CM-SCE-TP

Military Grade  
Tie-On Cable Marker



These non-adhesive labels can be used to identify large cables and wire bundles in particularly aggressive environments. Can be applied post cable termination using cable ties.

Manufactured using specially developed radiation cross-linked flame retarded polymer. Typical installation include mass transit, military and aerospace.

Colours available are White (9) or Yellow (4).

### Features & Benefits

- Highly flame resistant - excellent resistance to burning (Oxygen Index 35%).
- Resistant to key industrial and military grade fluids, as defined by RW-2513.

### Operating Temperature Range

- -55°C to +135°C

High temperature version **HTCM-SCE-TP** also available offering 225°C please call us.

### Specifications and Approvals

- SAE AS 5942
- MIL-STD-202F Method 215
- EN45545-2 Class 3, R24, HL3
- NFPA130
- UL MH26328 Group PG1S2

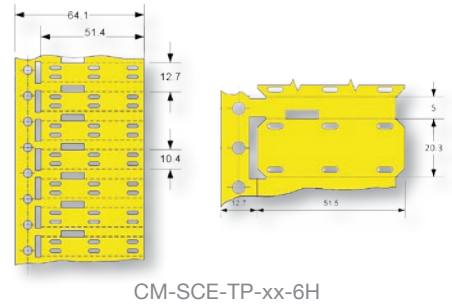
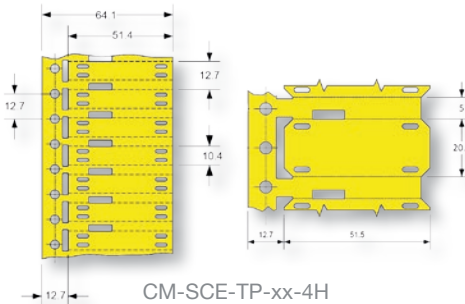

Ordering Description	Size (inch)	Markable Height mm	Markable Length mm	Recommended Range mm	Pack Size
<b>4 Tie Holes</b>					
CM-SCE-TP-1/4-4H-4 or 9	1/4	6.4	50.80	5.08 to 12.50	250 pcs
CM-SCE-TP-1/2-4H-4 or 9	1/2	12.70	50.80	12.50 and up	250 pcs
<b>6 Tie Holes</b>					
CM-SCE-TP-1/4-6H-4	1/4	6.4	50.80	5.08 to 12.50	250 pcs
CM-SCE-TP-1/2-6H-4 or 9	1/2	12.70	50.80	12.50 and up	250 pcs

Alternative packaging sizes also available please ask for details

Recommended printers: **T200-IDENT-PRINTER** and the **TE3112** printer.

Approved ribbon **1966-RIBBON**

# Wire and Cable Markers

## HLX125-NEL

Halogen free, Low Fire hazard  
Tie-On Cable Marker

1 Low Fire Hazard, UV stabilised, cross-linked polyolefin Cable Markers, assembled in a  
2 Narrow Edge Leading 'NEL' format. Consisting of a continuous strip formed into punched  
3 tie on Cable Markers. Cable Markers have perforated edges for easy removal

4 Markers are printed by a computer-based system and are attached using cable ties.  
5 Ideal for applications where low fire hazard characteristics (low smoke, low toxicity and low  
6 flammability) are critical.

7 Standard colours available are White or Yellow.

### Features & Benefits

- Recommended for use where combustion of products may endanger personnel or delicate electronics.
- Two formats available.
- Ideal for pre or post termination assembly.

### Operating Temperature Range

- -40°C to +105°C



### Specifications and Approvals

- SAE AS5942
- MIL-STD-202 Method 215
- London Underground 1-085 A3
- EN45545-2 R22/R23/R24 HL3
- BS 6853 Vehicle cat 1a
- NF F 16-101 Class A1

Ordering Description	Marker Dimensions mm	Printable Area mm	No. Markers Across	Pack Size
HLX125-Colour-4NEL60S	80.0 x 12.5	60.0 x 10.5	4	200 pcs per roll
HLX125-Colour-2NEL60S	80.0 x 12.5	60.0 x 10.5	2	200 pcs per roll

Recommended printers: T200-IDENT-PRINTER and the TE3112 printer.  
Approved ribbon 1966-RIBBON



## PM316 Metal

Stainless Steel  
Tie-On Cable Marker



For additional information on this product, associated part number and options please contact us direct.

Typical sizes are:

- 95 x 12mm, printable area 55 x 10mm
- 85 x 12mm, printable area 50 x 10mm
- 75 x 7mm, printable area 50 x 5mm

Permark® 316 stainless steel markers are recommended for use in highly demanding applications. Using state of the art technology and no inks, the marking process produces a permanent, deep surface mark with a darkened character in high contrast to the background.

Pre-print service option only.

Offering excellent resistance to a variety of hydrocarbons, organic chemicals, acids, alkali and inorganic salts.

### Features & Benefits

- Pre-marked to customer requirements.
- Variety of fixing methods possible.
- Mark will endure the lifetime of a Permark stainless steel marker.
- Excellent resistance to weather extremes and high levels of UV light.
- Resistant to corrosive marine and industrial atmospheres.
- Excellent resistance to a variety of hydrocarbons, organic chemicals, acids, alkalis & inorganic salts.

For resistance to a specific chemicals and substances, please contact us.

### Operating Temperature Range

- -80°C to +500°C

#### Ordering Description

As these parts are made to order please contact us for details.

# Wire and Cable Markers

## Label Selection Chart

### Adhesive Identification Labels Overview

Range of self-adhesive labels available in various forms and colours for either self printing or using our pre-print service.



Product	UL	ASTM D3330	SAE AD 4952	BMS 13-47	Operating Temperature	Size	Standard Colours			Non Standard Colours	Description
							Thermal Printing	White	Metalised		
SBP	•	•			-40°C to +80°C	Various	•	•			Self-laminating
PVF				•	-40°C to +107°C		•	•			Self-laminating
MP	•		•		-40°C to +150°C		•		•		Metalised polyester
MV	•				-40°C to +150°C		•		•		Temper evident
WP	•		•		-40°C to +150°C		•	•			Polyester
TTP	•	•			-29°C to +150°C		•	•	•	•	•
Raymark A4					-40°C to +105°C	A4		•			Ink-jet printable

## SBPlus

Self-laminating Labels  
Thermal Transfer Printable



### Specifications and Approvals

- ASTM D3330
- ASTM 3611
- MIL-STD-202 Method 215
- UL969 PGJ12 MH17292

Clear vinyl film with a permanent acrylic based adhesive, supplied with a white thermal transfer printable area, which is over-laminated upon application with the clear portion of the label.

Can also be 'flagged' around a wire rather than wrapped. This self-laminating feature protects the printed area from exposure to oil, solvents, water and abrasion.

Printable area is equal to the width of the label and the printable height as identified in the table below.

Standard colour is White with a clear tail.

### Features & Benefits

- Strong adhesive, prevents lift off and seals.
- Base material allows the printing to remain clear after lamination.
- Designed to withstand exposure to oil, solvents and water.

### Operating Temperature Range

- -40°C to +110°C

Ordering Description	Label Size mm		Printable Height mm	Max. Cable OD mm	No. Labels Across	Pack Size
	Height	Width				
SBP050100WE10	25.4	12.7	8.5	5.1	5	10,000
SBP050143WE10	36.5	12.7	12.7	7.6	5	10,000
SBP075094WE10	23.9	19.1	9.5	7.6	4	10,000
SBP080150WE10	38.1	20.3	12.7	7.6	4	10,000
SBP100143WE5	36.5	25.4	12.7	7.6	3	5,000
SBP100225WE5	57.2	25.4	19.1	12.2	3	5,000
SBP100375WE2.5	95.3	25.4	25.4	22.4	3	2,500
SBP100594WE1	151.0	25.4	38.1	35.6	3	1,000
SBP100743WE1	188.9	25.4	38.1	35.6	3	1,000
SBP190319WE2.5	81.0	48.3	19.1	12.2	2	2,500
SBP190594WE1	151.0	48.3	38.1	35.6	2	1,000
SBP200143WE2.5	6.5	50.8	12.7	7.6	2	2,500
SBP200225WE2.5	57.2	50.8	19.1	12.2	2	2,500
SBP200375WE2.5	95.3	50.8	25.4	22.4	2	2,500
SBP200743WE	188.9	50.8	38.1	48.3	2	11,000

Recommended printers **T200-IDENT-PRINTER** and the **TE3112** printer.

Approved ribbon **TMS-RJS-RIBBON-4RPSCE**

# Wire and Cable Markers

## PVF

Self Laminating Labels  
Thermal Transfer Printable

1 Translucent polyvinyl fluoride film with a permanent acrylic adhesive, designed for wire and cable marking applications that require the 'self-extinguishing' properties of polyvinyl fluoride. Supplied with a white printable area, which is over-laminated upon application.

2 PVF has a low-profile design making it suitable for wrapping onto thin wire gauges as well as excellent conform-ability to round, irregular or flexible surfaces and is ideal for wire & cable identification, including flat ribbon cables that are subject to repeated bending.

### Features & Benefits

- Thermal transfer printable
- Excellent UV resistance
- Excellent conform-ability to round, irregular and flexible surfaces.
- High resistance to aging

### Operating Temperature Range

- -40°C to +107°C

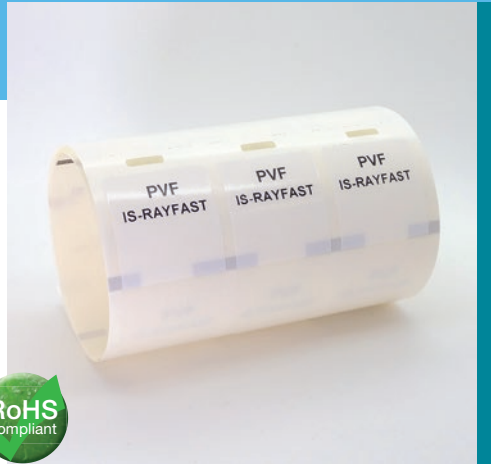

### Specifications and Approvals

- ASTM D1000-76
- AS-81531
- MIL-STD-202 Method 215
- MIL STD 833C
- BMS 13-47
- NGM802AK

Ordering Description	Label Width mm	Label Height mm	Labels Across	Pack Size
PVF050100WE10	12.7	25.4	5	10,000
PVF080150WE10	20.3	38.1	4	10,000
PVF100143WE5	25.4	36.5	3	5,000
PVF200143WE2.5	50.8	36.5	2	2,500
PVF100225WE5	25.4	57.2	3	5,000
PVF190319WE205	48.3	81.0	2	2,500
PVF100375WE2.5	25.4	95.3	3	2,500
PVF200375WE2.5	50.8	65.3	2	2,500
PVF100594WE1	25.4	151.0	3	1,000
PVF100743WE1	25.4	188.9	3	1,000
PVF190594WE1	48.3	151.0	2	1,000
PVF200743WE1	50.8	188.9	2	1,000

Recommended printers: T200-IDENT-PRINTER plus the TE3112 printer  
Approved ribbon 1330-3300-10



#### Specifications and Approvals

- ASTM AS 4952
- MIL-STD-202 Method 215
- FTM-1
- UL969 PGJ12 MH17292
- UL969 PGJ18 MH17292 (Canadian)

MP is a thermal transfer printable metalised polyester film with permanent acrylic adhesive, designed for rating plates and other applications that require a metal look, such as nameplates, equipment labels, detailed product information labels and serial number plates. MP is UL Listed and CSA certified.

Standard colour is Silver, metalised polyester

#### Features & Benefits

- Thermal transfer printable
- Several die-cut sizes available
- Metalised appearance
- UL listed and CSA certified
- Ideal for rating plate applications

#### Operating Temperature Range

- -40°C to +150°C

The table below only represents a selection of MP label products available, for a complete list or more detailed information please contact us for details.

Ordering Description	Label Width mm	Label Height mm	Labels Across	Pack Size
MP-080080-10-8A	8.0	8.0	8	10,000
MP-095080-25-8A	9.5	8.0	5	25,000
MP-127111-10-8A	12.7	11.1	5	10,000
MP-165102-10-8A	16.5	10.2	5	10,000
MP-191114-18-8A	19.1	11.4	3	15,000
MP-254045-10-8A	25.4	4.6	3	10,000
MP-254127-10-8A	25.4	12.7	3	10,000
MP-445102-5-8A	44.5	10.2	1	5,000
MP-762508-2.5-8A	76.2	50.8	1	2,500

Recommended printers: T200-IDENT-PRINTER plus the TE3112 printer

Approved ribbon 1330-0607-10

# Wire and Cable Markers

## MV

White Polyester Labels  
Thermal Transfer Printing

MV is a thermal transfer printable metalised polyester film with a permanent acrylic adhesive, designed with a tamper-evident feature which leaves a 'VOID' footprint when removed. It is ideal for applications such as rating plate and serial number labels that require protection against removal. Standard colour is Silver, metalised polyester.

### Features & Benefits

- Thermal transfer printable
- Metalised appearance
- Ideal for security applications
- UL recognised

### Operating Temperature Range

- -40°C to +150°C

The table below only represents a selection of MV label products available, for a complete list or more detailed information please contact us for details.

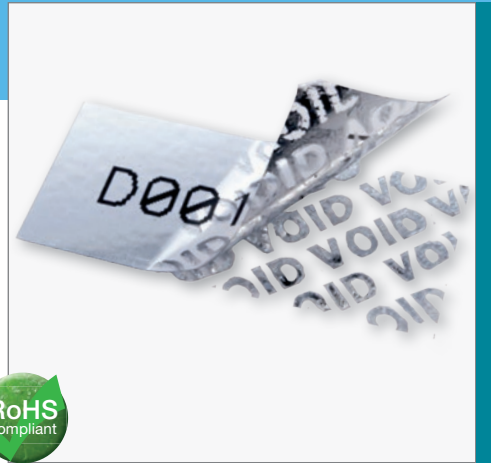

### Specifications

- MIL-STD-202 Method 215
- AS-81531
- UL969 PGJ12 MH17292

Ordering Description	Label Width mm	Label Height mm	Labels Across	Pack Size
MV-040040-25-8A	4.0	4.0	20	25,000
MV-089047-10-8A	8.9	4.7	5	10,000
MV-095095-10-8A	9.5	9.5	7	10,000
MV-127127-10-8A	12.7	12.7	5	10,000
MV-191114-15-8A	19.1	11.4	3	15,000
MV-254064-10-8A	25.4	6.4	3	10,000
MV-254097-10-8A	25.4	9.7	3	10,000
MV-381191-5-8A	38.1	19.1	2	5,000
MV-508127-8-8A	50.8	12.7	1	5,000
MV-762508-2.5-8A	76.2	50.8	1	2,500
MV-101508-2.5-8A	101.6	50.8	1	2,500
MV-101101-1.3-8A	101.6	101.6	1	1,300

Recommended printers: T200-IDENT-PRINTER and the TE3112 printer.  
Approved ribbon 1330-0607-10

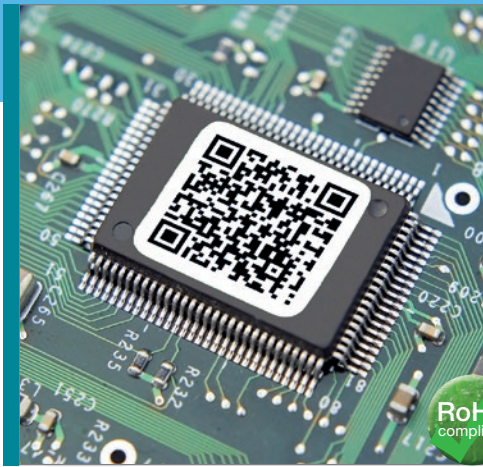

WP is a white polyester film with a permanent acrylic adhesive. It is ideal for bar coding, PCB and component labelling, as well as general purpose labelling applications that require a high durability white label. WP is resistant to a variety of solvents while maintaining print quality. It is UL listed and print performance and durability are reliable when used with specified ribbons.

Standard colour available is White.

#### Features & Benefits

- Ideal for use on PCB component labelling
- Ink receptive topcoat
- Excellent for bar code applications
- UL listed and CSA certified

#### Operating Temperature Range

- -40°C to +150°C

The table below only represents a selection of WP label products available, for a complete list or more detailed information please contact us for details.

#### Specifications and Approvals

- ASTM AS 4952
- MIL-STD-202 Method 215
- FTM-1
- UL969 PGJ12 MH17292
- UL969 PGJ18 MH17292 (Canadian)

Ordering Description	Label Width mm	Label Height mm	Labels Across	Pack Size
WP-127111-10-9	12.7	11.1	5	10,000
WP-165051-25-9	16.5	5.1	4	25,000
WP-171171-10-9	17.1	17.1	5	10,000
WP-191064-10-9	19.1	6.4	4	10,000
WP-229064-10-9	22.9	6.4	3	10,000
WP-254064-10-9	25.4	6.4	3	10,000
WP-254127-10-9	25.4	12.7	3	10,000
WP-318064-10-9	31.8	6.4	1	10,000
WP-381191-5-9	38.1	19.1	2	5,000
WP-508127-5-9	50.8	12.7	1	5,000

Recommended printers: **T200-IDENT-PRINTER** and the **TE3112** printer.

Approved ribbon **1330-0607-10**

# Wire and Cable Markers

## TTP

Continuous Polyester for Decals  
Thermal Transfer Printable

This highly durable system offers the features of 'Silk Screened' labels, only without the cost, time and inflexibility involved. The product utilises high performance polyester with permanent adhesive, suitable for panel labels, fascias and decals.

### Features & Benefits

- Effective alternative solution for expensive silk-screen printing
- Continuous format
- Several widths and colours available
- Interior and exterior aircraft use including flight entertainment and deck instrumentation.

### Operating Temperature Range

- Clear from -40°C to +125°C
- Other from -29°C to +150°C



### Specifications and Approvals

- A-A-59485
- GAT100BB
- UL MH17292 Group PGJ12 (polywhite)

Ordering Description	Label Width mm	Roll Length m	Qty per Pack
Standard adhesive version			
TTP200-Colour-10	50.8	30.48m (100ft)	Continuous Roll
TTP300-Colour-10	73.2	30.48m (100ft)	Continuous Roll
TTP400-Colour-10	101.6	30.48m (100ft)	Continuous Roll
TTP600-Colour-10	152.4	30.48m (100ft)	Continuous Roll
High tack adhesive version			
TTPA200-Colour-10	50.8	30.48m (100ft)	Continuous Roll
TTPA300-Colour-10	73.2	30.48m (100ft)	Continuous Roll
TTPA400-Colour-10	101.6	30.48m (100ft)	Continuous Roll
TTPA600-Colour-10	152.4	30.48m (100ft)	Continuous Roll

Ordering Information: Standard colours: **CL** = Clear, **WE** = White and **MP** = Metalised  
Non-Standard: **RD** = Red, **GN** = Green, **BE** = Blue; **OE** = Orange, **BK** = Black and **YW** = Yellow

Recommended printers: T200-IDENT-PRINTER and the TE3112 printer.

Approved ribbon 1330-0607-10



## Raymark RMK A4

Epoxy Coated Labels  
Computer Printable

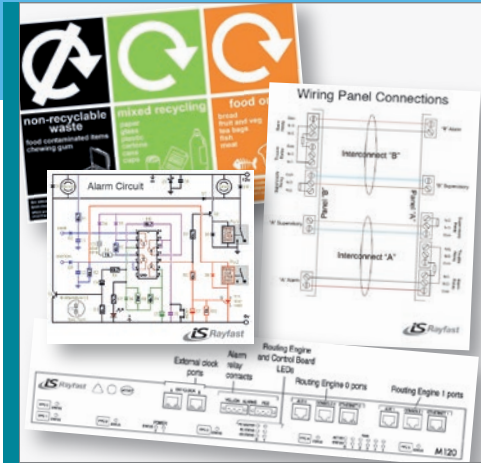

Raymark is a computer printer label stock with outstanding fluid and abrasion resistance, for ink-jet printers.

When heat-cured after printing, the heat reactive epoxy surface “locks-in” the printed image. Typical applications are rating plate labels, wiring diagrams, component identification and wraparound markers.

Standard colour available is White

### Features & Benefits

- Outstanding adhesion to many surfaces
- Outstanding fluid and abrasion resistance.
- Low fire hazard properties
- Indoor use only

### Operating Temperature Range

- Wire marking -40°C to +85°C
- Panel marking -40°C to +105°C

### Specifications and Approvals

- MIL-M-81531 (mark permanence)
- MIL-STD-202F Method 215 (solvent resistance)

Ordering Description	Label Height mm	Label Width mm	No. Labels / reel	Pack Size
RMK-9x25-A4	9	25	132 labels	50 Sheets
RMK-18x35-A4	18	35	48 labels	50 Sheets
RMK-18x50-A4	18	50	36 labels	50 Sheets
RMK-25x50-A4	25	50	27 labels	50 Sheets
RMK-25x75-A4	25	75	18 labels	50 Sheets
RMK-35x75-A4	35	75	12 labels	50 Sheets
RMK-25x100-A4	25	100	10 labels	50 Sheets
RMK-50x100-A4	50	100	5 labels	50 Sheets
RMK-75x150-A4	75	150	3 labels	50 Sheets
RMK-UNCUT-A4	A4	A4	1 label	50 Sheets

A standard pack contains 50 sheets in environmentally sealed package, if opened the labels should be stored at a temperature no greater than +25°C @ ,80% humidity and used within 6 months. An un-opened pack can be stored at a temperature no greater then +35°C and has a recommended shelf life of 12 months.

For full product performance characteristics, refer to product data sheets TH-93269 (UK) and H54584 (USA).

Recommended printers: New Raymark ink jet printer EPSON WF-5190DW.

Also refer to the TE 411-121005 (ribbon/ink matrix)

# Wire and Cable Markers

## WinTotal

Software Solution  
Design and Print

1 WinTotal is a label/marker design package that makes wire marker printing simple in an industrial environment. Running in the familiar  
2 Windows environment, WinTotal v6 has 2,500 standard TE Connectivity (TE) Identification products pre-installed. This makes the creation and printing of Identification sleeves or labels a quick and simple task. Using the advanced editor, it is also possible to create complex  
3 layouts that relate to active data fields, giving a true WYSIWYG representation.

4 WinTotal v6 now fully supports Unicode. This allows for multilingual text to be printed using any or all of the languages required.  
5 If a character has a Unicode equivalent, then WinTotal v6 will display and print that character, if it can be written into a Microsoft application, it can be copied into WinTotal v6.

### Key Features & Benefits

- Multi-lingual user interface.
- Pre-loaded WYSIWYG templates.
- Graphical user interface with WYSIWYG display
- Clipart gallery with commonly used symbols, on V6 and above only.
- Incremental alpha and numeric fields.
- Accepts and prints data in any language - UniCode data support (V6 only).
- Multiple Label Design Objects: Text, lines, boxes, circles and images.
- Double sided marker printing complete with WYSIWYG display.
- Extensive Barcode and 2D barcode support.
- Advanced label design elements & tools: Text boxes, rich text formatting, variable font size.
- Image files supported (JPG, WMF, BMP).
- Multiple Printers/Printing: Full MAPP (Multiple Application Port Printing). Able to drive multiple printers simultaneously with automatic selection.

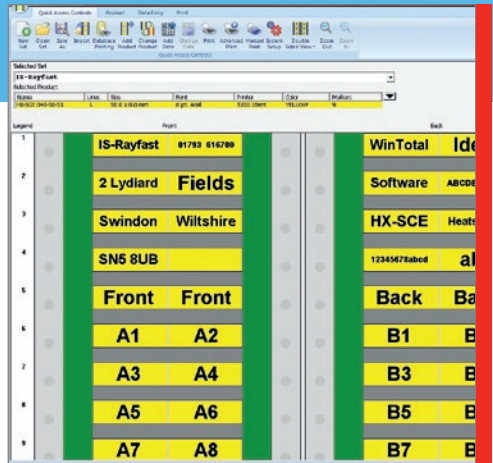

### System Requirements

Computer	IBM Compatible PC
Processor	1 GHz or higher
RAM	1GB
Screen Resolution	1024 x 768 pixels
Disk Space Required	100MB of free disk space

### Ordering Information

USB key with licence, once inserted. **WINTOTAL-6-DONGLE**

\*RAM requirement is less for earlier Windows operating systems please contact for details

### Basic Functionalities

- Toolbar design, 'Keypad' buttons, 'Zoom In/Out'.
- 'Selected Product' list box
- Simplified user interface configurable for both basic and advanced users
- Single file data format: One file now replaces multiple files used in older versions.
- 'System Setup' screen with simplified printer selection: 'Advanced Printer Setup' function shows all settings in one location.

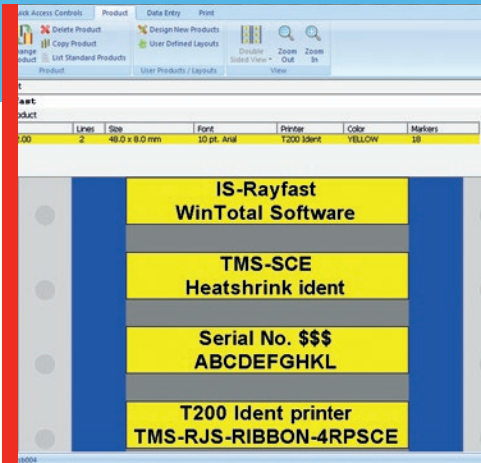

### Data Management

- Import data from ASCII or XMT files or from a Windows database
- 'Database printing' function for printing data without importing into WinTotal software
- 'Preview' option to review the import configuration without importing.

### Templates

- 'Rotation' option when creating products
- File format supporting importing and exporting of 'User Defined Layouts'.

### Supported Languages

Dutch, English, French, German, Italian, Japanese, Korean, Norwegian, Portuguese (Brazil), Russian, Simplified Chinese, Spanish and Turkish.

### Note

The WinTotal software package is available to suit a Windows® environment and is constantly being developed in line with operating system updates and technology improvements, please enquire for latest release levels.

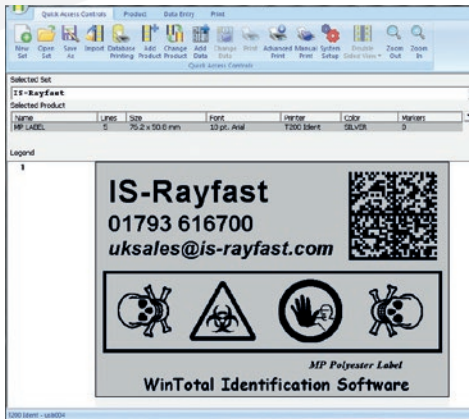

Please note that the WINTOTAL-6-DONGLE acts as an authorisation key, the software can be downloaded as a free trial from the TE.com website which this key activates for unrestricted use.

# Wire and Cable Markers

## T200-IDENT-PRINTER

Thermal Transfer Printer

1 Get the most out of your cable identification and labelling. The T200 Ident printer brings together a complete solution for your compact range of thermal transfer printing needs. The increased accuracy and the added flexibility of a movable Media sensor extends the variety of products approved for this printer, while reducing the number of misprints. The T200 is also available as a package with the WINTOTAL Software

### Features & Benefits

- Light-weight at 4kg and small footprint
- Automatic calibration
- Simple ribbon and media loading procedure
- Superior print positioning accuracy
- Touch Screen
- Full DHCP and LAN connection

### Compact Size

- D322mm x H189mm x W253mm

### Electrical

- 100 to 240 V | 50/60 Hz | FPC

### Operating Conditions

- 5°C to 40°C
- 25 to 85% non-condensing RH

### Printing Method

- 300 dpi Thermal Transfer

### Printing Speed

- 30, 40, 50, 75, 100 & 125 mm/s (recommended 50 mm/s).

### Product Properties

- Print width max: 105.7mm
- Label width 4mm to 105.7mm
- Label height: 5mm to 1,000mm

### Approvals & Declarations

- CE, FCC Class A, CB, CCC, UL, GOST

### Interfaces

- USB 2.0 (full speed)
- LAN 10/100 Base (Ethernet)



### Ordering Information

Standard printer	T200-IDENT-PRINTER
... with Wintotal	T200-IDENT-SWARE-PRINTER

### Spare Parts and Accessories

Print head	T200-PRINTHEAD
Drive roller	T200-DR4-DRIVEROLLER
Cutter	T200-CUTTER
Perforator	T200-PERFORATOR
Universal Payoff	UNIVERSAL-PAYOFF

For additional information please give us a call

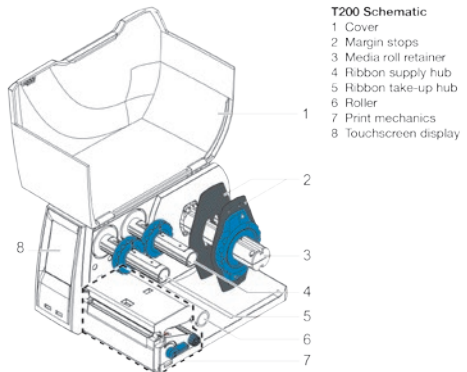

## TE3112-PRINTER

Thermal Transfer Printer



### Ordering Information

Standard printer **TE3112-PRINTER**

### Spare Parts and Accessories

Print head	<b>TTC-PRINthead-300</b>
Drive roller	<b>TTC-ROLLER</b>
Media Sensor	<b>TTC-3000-MEDIA SENSOR</b>
Cutter	<b>TTC-CUTTER</b>
Perforator	<b>TTC-PERFORATOR</b>
Metal Cover	<b>TE3112-METAL-COVER</b>
Universal Payoff	<b>UNIVERSAL-PAYOFF</b>

For additional information please give us a call

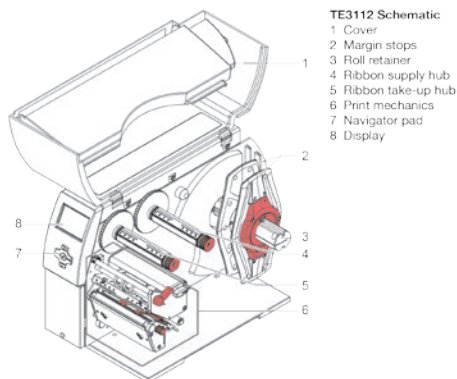

The TE3112 printer is a high performance mid-range identification printer for marking Heat-shrinkable Marker Sleeves, Cable Marker Tags and labels. With a 300 dpi print head, it's capable of marking a broad range of products for use in commercial and industrial environments.

### Features & Benefits

- High accuracy printing
- Light-weight at 9kg
- Automatic calibration
- Centre justification of the print media
- Easy to fit accessories
- Prints onto small 2.4mm marker sleeves

### Dimensions

- D446mm x H274mm x W242mm

### Electrical

- 100 to 240 V | 50/60 Hz
- 250W max, 45W Typical, 9W Power save

### Operating Conditions

- 5°C to 40°C
- 10 to 85% non-condensing RH

### Printing Method

- 300 dpi Thermal Transfer

### Printing Speed

- 30, 40, 50, 75, 100 & 125 mm/s (recommended 50 mm/s).

### Product Properties

- Print width max: 105.6mm
- Label width 4mm to 105.6mm
- Label height: 5mm to 4,000mm

### Approvals & Declarations

- CE, FCC Class A, CB, CCC, UL, GOST

### Interfaces

- USB 2.0 High (full speed)
- LAN 10/100 Base (Ethernet)
- Serial RS 232 C 1.200 up to 230.400 Baud/8 Bit

# Wire and Cable Markers

## RIBBONS

Thermal Transfer Printer Ribbons  
Product Cross Ref.



1 It is essential that the combination of printers,  
2 products and ribbons are correct, to ensure  
3 the best print quality and mark permanence.  
4 Each combination has been evaluated for print  
5 quality and tested for mark permanence. The  
6 table below illustrates the standard ribbons  
7 available for the two printers T200 and TE3112.

Compatible Products	Standard Ribbon
<b>Cable Identification Markers</b>	
CM-SCE-TP	1966-RIBBON
D-SCE	1966 RIBBON or TMS-RJS-RIBBON-4DSCE
HLX125	1966-RIBBON
HT-SCE	TMS-RJS-RIBBON-4HT or T300-RIBBON-WH-4HT
HT-SCE (Black)	T300-RIBBON-WH-4HT or TMS-RJS-RIBBON-4HT
HX-SCE	1966-RIBBON
RPS	TMS-RJS-RIBBON-4RPSCE
TMS-SCE	TMS-RJS-RIBBON-4RPSCE
TMS-SCE (Black)	T300-RIBBON-WH (White) or TMS-RJS-RIBBON-4AG (Silver)
TMS-90-SCE	1966-RIBBON
UV-SCE	T300-UV-SCE-RIBBON
ZHD-SCE	1966-RIBBON
<b>Labels</b>	
SBPlus	TMS-RJS-RIBBON-4RPSCE
TTP	1330-0607-10
MP	1330-0607-10
WP	1330-0607-10
MV	1330-0607-10
PVF	1330-3300-10

**1966-RIBBON**

Ultra-high performance black thermal transfer ribbon that produces the ultimate in print performance.

Ink type: Resin

**FEATURES AND BENEFITS**

- Ideal for use in environments where marker may come into contact with abrasion, solvent or chemical attack

**TMS RJS-RIBBON-4DSCE**

High performance black thermal transfer ribbon, for use on D-SCE heat shrinkable sleeves.

Ink type: Wax

**FEATURES AND BENEFITS**

- TMS RJS-RIBBON-4DSCE printed legends have high resistance to fluids, especially diesel.

**TMS RJS-RIBBON-4RPSCE**

High durability commercial grade black thermal transfer ribbon, for use with TMS-SCE and RPS heat shrinkable sleeves and SBPlus labels.

Ink type: Wax/Resin

**FEATURES AND BENEFITS**

- TMS RJS-RIBBON-4RPSCE printed legends have high resistance to abrasion, solvents and chemicals

**TMS RJS-RIBBON-4HT**

High temperature black thermal transfer ribbon, for use with HT-SCE heat shrinkable sleeves.

Ink type: Resin

**FEATURES AND BENEFITS**

- TMS RJS-RIBBON-4HT printed legends have excellent resistance to high temperatures.

**T300-RIBBON-WH-4HT**

A white resin based thermal transfer ribbon, for use on HT-SCE product range.

Ink type: Resin

**FEATURES AND BENEFITS**

- T300-RIBBON-WH-4HT printed legends have high resistance to abrasion, solvents and chemicals.

**1330-0607-10**

High durability black resin thermal transfer printable ribbon, ideal for use on pressure sensitive labels.

Ink type: Resin

**FEATURES AND BENEFITS**

- Excellent resistance to abrasion and chemicals.

**1330-3300-10**

High durability black resin thermal transfer printable ribbon, ideal for use on pressure sensitive labels.

Ink type: Resin

**FEATURES AND BENEFITS**

- Excellent resistance to chemicals.

**T300-UV-SCE-RIBBON**

High performance resin based thermal transfer ribbon, for use on UV-SCE product range.

Ink type: Resin

**FEATURES AND BENEFITS**

- T300-UV-SCE-RIBBON printed legends have high resistance to abrasion, solvents and chemicals.
- T300-UV-SCE-RIBBON has excellent UV resistance properties.

# Wire and Cable Markers

## Additional Ident' Products

Printer Universal Payoff and  
Push-On Markers

### 1 **EC9926-000 Universal Payoff**

2 The Universal Payoff is a free standing bench  
3 top, or wall mounted stand. Designed to  
4 dispense all TE Connectivity identification  
5 marker sleeves, cable markers and labels.

#### 6 **Key Features and Benefits**

- Free standing bench top.
- Wall mountable for space saving.
- Robust, all metal stand.
- Maximum outside roll diameter 400mm
- Size 300 (D) x 232 (H) x 200 (W) mm
- Weight 2.23kg.

6 TE Part Number: **EC9926-000**



### 7 **Pre-Printed Push-On Markers**

8 A range of cold applied push-on markers are  
9 also available for wire and cable marking,  
10 including...

- KTMS-501 heat shrinkable bandolier
- Z-Type Marker
- K-Type Marker
- STD-Type Marker

11 Please contact us for additional information.

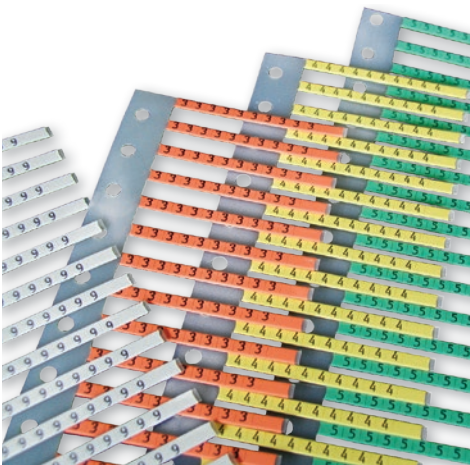





We have a full electronic capability, to receive and manipulate customer files for printing. Printing capabilities include logos, barcodes, images and a full range of text fonts.

Working closer with our customers providing practical design solutions, full technical support, site visits, system demonstrations and after sales support. Our in-house design and printing capabilities include a full range of text fonts, sequential numbering, logos, barcode, images and personalised graphics.

- Heat Shrinkable Sleeves
- Metal Photo Labels
- Tie-on Cable Markers
- Custom Self-adhesive Labels
- Pre-printed Markers
- Engraved Materials
- Complete Sets and Kits
- Barcodes and Logos

Custom designed solutions is an area of particular interest to our customers for their bespoke identification needs. Where awkward shapes or harsh environments require a particular specialist solution, such as;

- Ruggedised label applied to contoured surface that needs to withstand mechanical abrasion, environmental weathering, plus chemical solvent abuse.
- Metalised permanent adhesive labels for evidence of tampering.
- Control switch panel foil for external application, to withstand UV.
- Etched identification diagrams available on various substrates for use where long term harsh environments require a permanently legible solution is required.

For further information on the Pre-print service capabilities available or to discuss your specific labelling requirements, please contact us.

