

# USER MANUAL

2-Bay Model

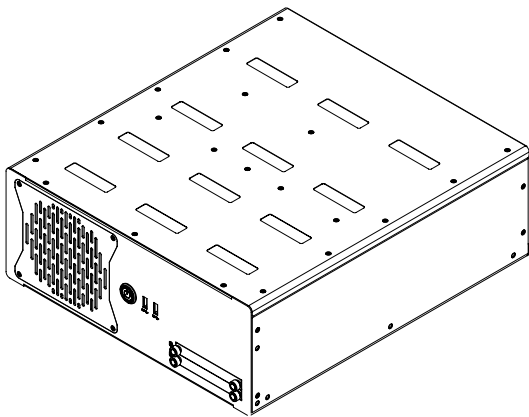

4-Bay Model

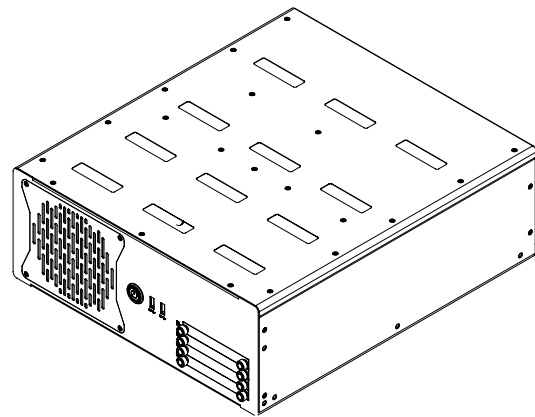

## HTC03 - Compact Computer

**Models:**

**HTC03-xx-AC yzzzzzz (Single AC power input)**  
**HTC03-xx-MP yzzzzzz (Multi-Power AC+DC inputs)**

where xx=CPU type (i3,i5,i7), y=manufacturing site, zz=configuration

User Manual HTC03	
Updated: 23 Nov 2021	Doc Id: INB100042-6 (Rev 04)
Created: 7495/363	Approved: 6987

Copyright © 2021 Hatteland Technology AS  
Eikeskogvegen 52, N-5570 Akسدal, Norway.

All rights are reserved by Hatteland Technology AS. This information may not, in whole or in part, be copied, photocopied, reproduced, translated or reduced to any electronic medium or machine-readable form without the prior written consent of Hatteland Technology AS. Review also: [www.hattelandtechnology.com/hubfs/pdf/misc/doc100703-1\\_permission\\_to\\_create\\_user\\_manuals.pdf](http://www.hattelandtechnology.com/hubfs/pdf/misc/doc100703-1_permission_to_create_user_manuals.pdf)

The products described, or referenced, herein are copyrighted to the respective owners. The products may not be copied or duplicated in any way. This documentation contains proprietary information that is not to be disclosed to persons outside the user's company without prior written consent of Hatteland Technology AS.

The copyright notice appearing above is included to provide statutory protection in the event of unauthorized or unintentional public disclosure.

**All other product names or trademarks are properties of their respective owners !**

WARNING: This is a class A product. In a domestic environment this product may cause radio interference in which case the user may be required to take adequate measures.

Statement above last revised 31 Jul. 2019

# Contents

<b>Contents .....</b>	<b>3</b>
Contents of package.....	6
<b>General .....</b>	<b>9</b>
IEC62368 policy - Introduction .....	10
About this manual.....	11
About Hatteland Technology.....	11
www.hattelandtechnology.com .....	11
Contact Information .....	11
Computers introduction .....	12
Product Labels (Examples) .....	13
<b>Installation.....</b>	<b>15</b>
Installation and mounting of computers.....	16
General mounting instructions.....	17
Cables .....	17
Unit Upgrade Precaution Note.....	18
Ferrite .....	19
Housing / Terminal Block Connector Overview .....	20
Cabinet cover removal.....	22
Installing PCIe Card / Rework PCI Bracket Options - Notice .....	23
HT 00275OPT-A1 (PCIe Card Bracket, Removal & Replacement) HL/FL/HH.....	25
Air Filter removal / replacement (H733S30Q20-SP000-0) .....	26
Front Fan removal / replacement .....	27
Mounting Bracket Kit (Desktop) HTC03 .....	28
Mounting Brackets for Console Mounting - HT 00226 OPT-A1 .....	29
19 inch Rack Kit 4U - HT 00223 OPT-A1 .....	30
Sliding Rails - HT 00224 OPT-A1 (20") / HT 00225 OPT-A1 (26") .....	30
Examples of mounting orientations to avoid.....	31
Replacing Internal CMOS/BIOS Battery.....	32
User Controls.....	34
Physical Connections .....	36
Module Expansion Matrix .....	41
Factory Preset COM Port Numbering.....	44
<b>Specifications .....</b>	<b>45</b>
Specifications - HTC03-xx-AC xxxxxxxx .....	46
Specifications - HTC03-xx-MP xxxxxxxx.....	47
<i>Multi-Power (AC+DC)</i> .....	47

# Contents

<b>Specifications Factory Options.....</b>	<b>49</b>
Specifications - NMEA / IEC COM Module RS-422 / RS-485 .....	50
<i>PCA200828-1</i> .....	50
Specifications - CAN Module with CO-Processor.....	54
<i>ZIA0001310-B</i> .....	54
Specifications - CAN Module with CO-Processor.....	55
<i>ZIA0001310-SLCAN</i> .....	55
Specifications - Isolated Digital Input/Output Module .....	56
<i>PCA100297-1</i> .....	56
Specifications - LAN Module .....	58
<i>PCA100298-1</i> .....	58
Specifications - Isolated COM Module RS-232 .....	59
<i>PCA100309-1</i> .....	59

<b>Specifications Accessories .....</b>	<b>61</b>
Specifications - External Modules (USB).....	62
Specifications - VSDDPVGA340 / HT DPM2VGAF-A1 .....	64
<i>DisplayPort to VGA adapter</i> .....	64
Specifications - RC3473 / HT DPM2DVI-DF-A1.....	65
<i>DisplayPort to DVI adapter</i> .....	65
Specifications - JH C01MF A-A .....	66

<b>Technical Drawings .....</b>	<b>67</b>
Technical Drawings - HTC03-xx-AC xxxxxxxx .....	68
Technical Drawings - HTC03-xx-MP xxxxxxxx .....	69
<i>Multi-Power (AC+DC)</i> .....	69

<b>Technical Drawings - Accessories.....</b>	<b>71</b>
Technical Drawings - HT MBK STD-C1 .....	72
<i>Mounting Bracket Kit HTC03/HTC04 - L-Shaped</i> .....	72
Technical Drawings - 19" Rack Kit 4U .....	73
<i>HT 00223 OPT-A1</i> .....	73
Technical Drawings - Mounting Brackets.....	75
<i>HT 00226 OPT-A1</i> .....	75
Technical Drawings - EN60945 PCI/PCIe Support Bracket.....	76
<i>HT 00275 OPT-A1</i> .....	76
Technical Drawings - External Modules (USB).....	77
Technical Drawings - 20" Slide Rails (for 19" Rack) .....	78
<i>HT 00224 OPT-A1</i> .....	78
Technical Drawings - 26" Slide Rails (for 19" Rack) .....	79
<i>HT 00225 OPT-A1</i> .....	79











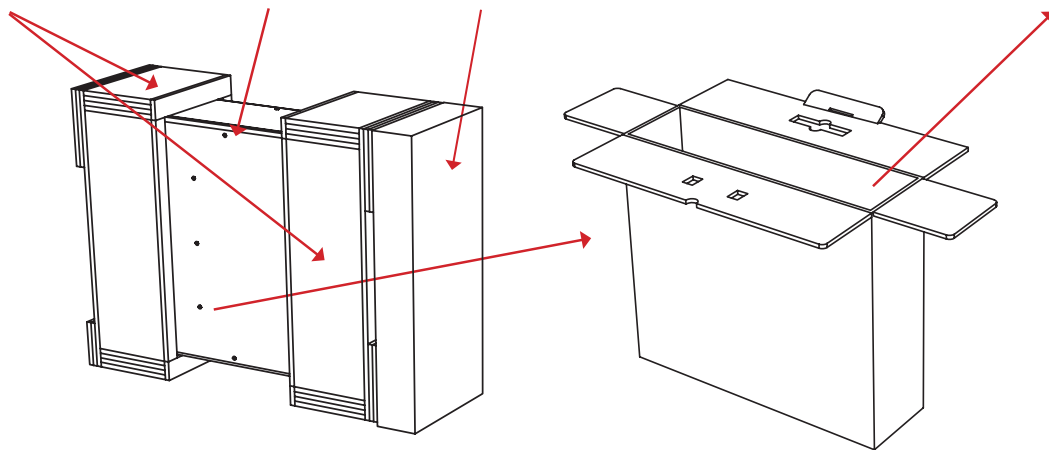

# Contents

<b>Appendixes .....</b>	<b>81</b>
SSD Selection Guide.....	82
BIOS - Overview and functions .....	86
BIOS - How to create RAID volume .....	135
BIOS - Hybrid Multi Monitor Configuration .....	137
WatchDog Timer function .....	138
Pinout Assignments .....	140
Trouble-shooting.....	143
Operating System Recovery (tool) .....	143
How to activate Windows Recovery Environment on OS Drive .....	147
IEC62368 policy for Hatteland Technology products.....	148
IEC62368 policy - Appendix .....	150
Chassis Thermal / Heat note .....	150
Declaration of Conformity .....	151
Return Of Goods Information .....	152
General Terms and Conditions .....	153
Notes .....	154
Revision History.....	156

# Contents of package

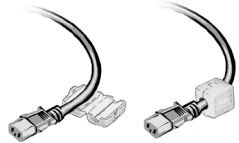
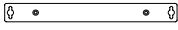
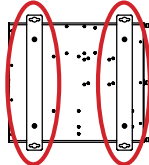

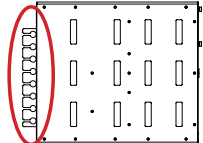
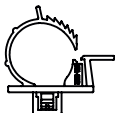
Stratocell packaging foam    HTC03 computer    Accessories Box (Contains items as listed below)    Outer Box



Item	Description	Illustration
 702002605	1 x Power Cable European Type F "Schuko" to IEC. Length 1.8m	EUR TYPE F 
 702002600	1 x Power Cable US Type B plug to IEC. Length 1.8m	US TYPE B 
 Würth 742 712 21 (1212004518-01) (split, 10.5mm)	1 x Würth 742 712 21  This ferrite is required when using 100/110/115V AC voltage on the power supply (not required for 230V AC) to be fully compliant with type approvals.  Review installation chapter for more information.	
 HT 00226 OPT-A1	Mounting brackets incl. screws (for console mounting)	
 HT RET STD-A3	Cable Retainer/Relief kit with 3 x Screws M3x4 DIN 965-10.9 Torx BLANK	
	Cable Relief for DP - kit consists of: 1 x DP cable tie (1990025128S000) 1 x DP cable mounting (1990036354S000) 1 x screw M3x5 (1930006255-01)	
	Test Reports papers: 1 x Product Declaration <b>TBD</b> 1 x Computer Checklist <b>TBD</b> 1 x BurnInTest Certificate <b>TBD</b>	

# Contents of package

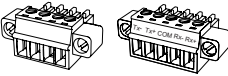
## Package may also include: (based on accessories/options ordered)

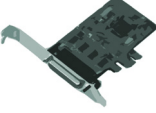
Item	Description	Illustration
 <p>Terminal Block Connectors</p>	<p>Depending on factory mounted options, connector kit as follows:            2 x 4-pin Terminal Block 3.81 for CAN Interface (ZIA0001310-B / ZIA0001310-SLCAN)            4 x 5-pin Terminal Block 3.81 for RS-422 / RS-485 NMEA 4 Channel (PCA100828-1)            4 x 5-pin Terminal Block 3.81 for Digital Input/Output (PCA100297-1)</p>	
 <p>PNY NVIDIA Quadro P2200</p>	<p>1 x Installation guide            1 x DP to DVI-D (SL) Adapter</p> <p><b>Not available for Multi-Power models</b></p>	
 <p>PNY NVIDIA Quadro P620</p>	<p>1 x Installation guide            1 x DVD with drivers/support software            4 x mDP to DP adapter*            or 4 x mDP to DVI (SL) adapter*            *Depends on ordered configuration</p> <p><b>Not available for Multi-Power models</b></p>	
 <p>CP114EL-I</p>	<p>1 x MOXA Cable with 4 ports</p>	

This page left intentionally blank







# General

# IEC62368 policy - Introduction

## Safety Instructions

Please read and understand the material in this manual in its entirety before doing any installation/servicing/upgrades. Personnel who are allowed to do work on the unit is detailed in the “**IEC62368 policy for Hatteland Technology product**” section later in this manual. Symbols pertaining to different personnel in regard to operations is described in the user manual.

### Based on requirements EN 62368-1:2014 and IEC 62368-1:2018

Authority	Description
<b>Children</b> 	This equipment is not suitable for use in locations where children are likely to be present.
<b>Ordinary person/ Sailor/End-User</b> 	Not allowed to open unit. Not allowed to install the unit. Not allowed to terminate/connect cables to the unit.
<b>Instructed person</b> 	Allowed to open hatches/latches which does not require tools, such as Disktrays. Allowed to open "battery-hatch" to change the battery even if tools are required. Allowed to install the unit. Allowed to terminate/connect cables to the unit indoors.
<b>Skilled person</b> 	Allowed to open and disassemble the unit.  Allowed to install the unit. Allowed to terminate/connect cables to the unit indoors and outdoors. Allowed to terminate/connect earth/ground wire.  Note: Be aware that additional definition for “skilled person” may apply, country dependent.

## About this manual

The manual contains electrical, mechanical and input/output signal specifications. All specifications in this manual, due to manufacturing, new revisions and approvals, are subject to change without notice. However, the last updated and revision date of this manual are shown both on the frontpage and also in the "Revision History" chapter. This user manual is a standard/general manual that applies to all variations of its product family, i.e. deviation from actual configuration may exist.

## About Hatteland Technology

Hatteland Technology is the leading technology provider of specialized display and computer products, delivering high quality, unique and customized solutions to the international maritime, naval and industrial markets.

The company represents innovation and quality to the system integrators worldwide. Effective quality assurance and investment in sophisticated in-house manufacturing methods and facilities enable us to deliver Type Approved and Mil tested products. Our customer-oriented approach, technical knowledge and dedication to R&D, makes us a trusted and preferred supplier of approved solutions, which are backed up by a strong service network.

## www.hattelandtechnology.com

You will find our website full of useful information to help you make an informed choice as to the right product for your needs. You will find detailed product descriptions and specifications for the entire range on Displays, Computers, Panel Computers and Military solutions as well as the range of supporting accessories. The site carries a wealth of information regarding our product testing and approvals in addition to company contact information for our various offices around the world, the global service locations and the technical support centre, all ensuring the best possible support wherever you, or your vessel, may be in the world.

## Contact Information

<p><b>Head office, Akdsal / Norway:</b> Hatteland Technology AS Eikeskogvegen 52 N-5570 Akdsal, Norway</p> <p>Switchboard: Tel: +47 4814 2200 mail@hattelandtechnology.com</p>	<p><b>Sales office, Frankfurt / Germany:</b> Hatteland Technology GmbH Werner Heisenberg Strasse 2, D-63263 Neu-Isenburg, Germany</p> <p>Elke Freisens: Tel: +49 173 6174753</p>
<p><b>Sales office, Oslo / Norway:</b> Hatteland Technology AS Strandveien 35 N-1366 Lysaker Norway</p> <p>Switchboard: Tel: +47 4814 2200 mail@hattelandtechnology.com</p>	<p><b>Sales office, Aix-en-Provence / France:</b> Hatteland Technology SAS Actimart- 1140, rue Ampère, CS 80544 13594 Aix-en-Provence, Cedex 3 France</p> <p>Mehdi Bounoua (Sales Director Europe, Middle East &amp; Africa): Tel : +33 6 88 33 64 93</p>
<p><b>Sales office, Vista / USA:</b> Hatteland Technology Inc 450 South Melrose Drive, Suite #107 Vista, CA 92081 USA</p> <p>Donna Pallonetti: Tel: +1 858-282-0659 Fax: +1 858-408-1834</p>	

For an up-2-date list, please visit <https://www.hattelandtechnology.com/contact>

## Computers introduction

Hatteland Technology's range of type-approved computers is designed to perform in harsh environments while providing the performance and flexibility you expect. We offer rack mount and black box/standalone computer solutions for every need. Our computers are used by system integrators, boat builders and end-users and can be found on all vessel types, all over the world.

If you are looking for a high quality computer for navigation, monitoring or entertainment solutions, Hatteland Technology can fulfil your high expectations at a reasonable cost.

Our computer range covers all eventualities and requirements. We offer a wide range of processor choices, SSD storage and power options, and solid state technology, neatly engineered within industry standard form factors such as 19" rack mount, 2U and 4U solutions.

We continually develop our computers portfolio to make the best use of emerging computer technology so you can be sure that your Hatteland Technology computer offers the power needed to run modern applications, with the flexibility to be installed wherever you want, for any marine use.

Designed to perform in harsh environments...

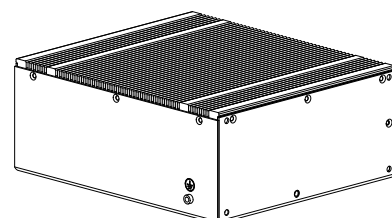
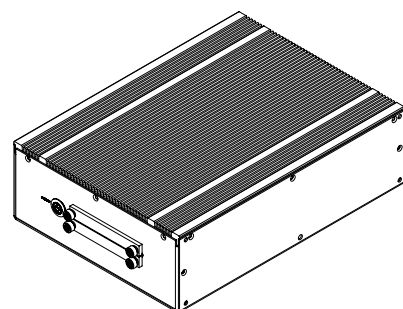
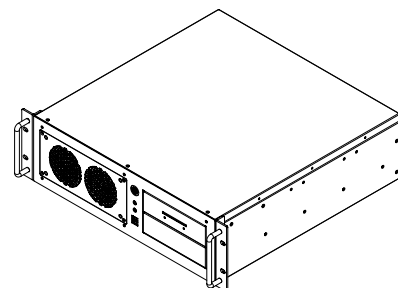
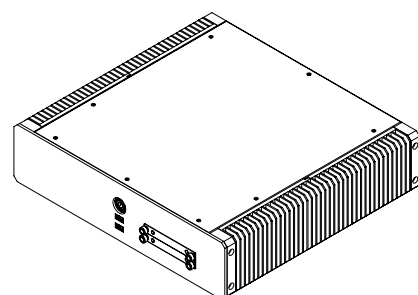
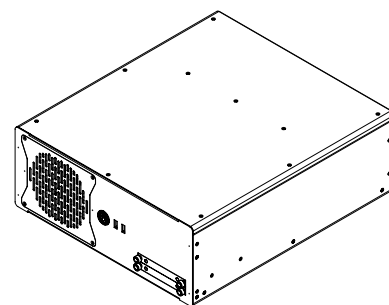



# Product Labels (Examples)

Only present if the unit was delivered with factory installed Operating System (OS) such as Microsoft® Windows® Embedded Enterprise. The same Product Key is also printed on the "Product Declaration" sheet that follows the unit, check contents of package. Note: For certain OS, there is no physical Product Key Label required or a Product Key Number that must be entered during installation / usage of the unit.

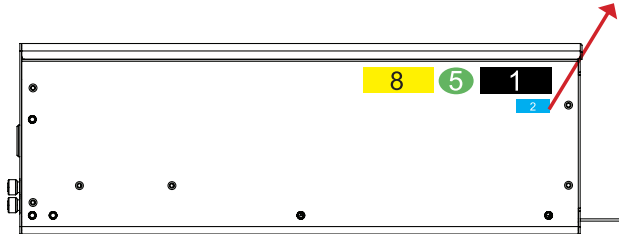
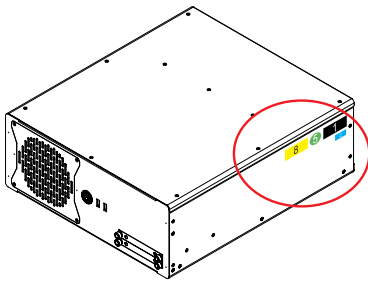

## Label Size and Types

ID	Label Layout	Description	Specification
1		<p><b>Type</b> : Serial Number Label  <b>Name</b> : Label B  <b>Size</b> : 60mm wide x 22mm high (rectangle size)                      Note: Text content of label will match specifications derived from Data Sheet.</p>	<p>Silver with glue on back, non-tearable and made for thermal transfer printing.</p>
2		<p><b>Type</b> : Operating System (OS) label.  <b>Size</b> : 22mm wide x 9mm high (rectangle size)                      Note: Label only present if OS was part of factory option order. Linux OS does not have any label.</p>	<p>As per delivered from supplier.</p> <p>Label applies for:                      Windows® 10 IoT Enterprise</p>
5		<p><b>Type</b> : Quality Control (QC) Label  <b>Size</b> : 30mm wide x 23mm high (oval size)</p> <p>This label indicates that the unit is produced, tested and packed according to the manufacture's QA specifications. It will include a Personal ID and signature by the personnell responsible for approving the unit in production, test and warehouse departments.</p>	<p>FLEXcon@PHARMcal@V 400 F                      WhiteTC-848V-23 TRACrite™ 150</p>
8		<p><b>Type</b> : Shock Hazard Caution Label  <b>Name</b> : Label B  <b>Size</b> : 60mm wide x 20mm high (rectangle size)</p>	<p>Silver with glue on back, non-tearable and made for thermal transfer printing.</p> <p>Rules specified in IEC62368-1:2018 annex L.8 and F.5. Applies for units with Dual/Multi-Power inputs only (more than 1 Power Input).</p>

# Product Labels (Examples)

## Serial Number Label Layout Example

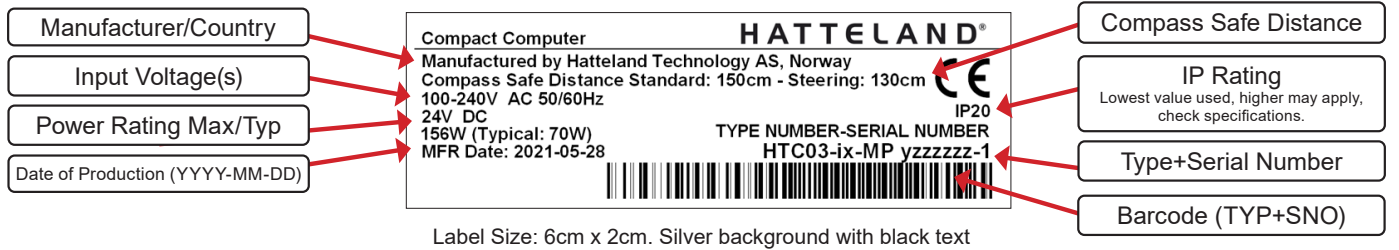
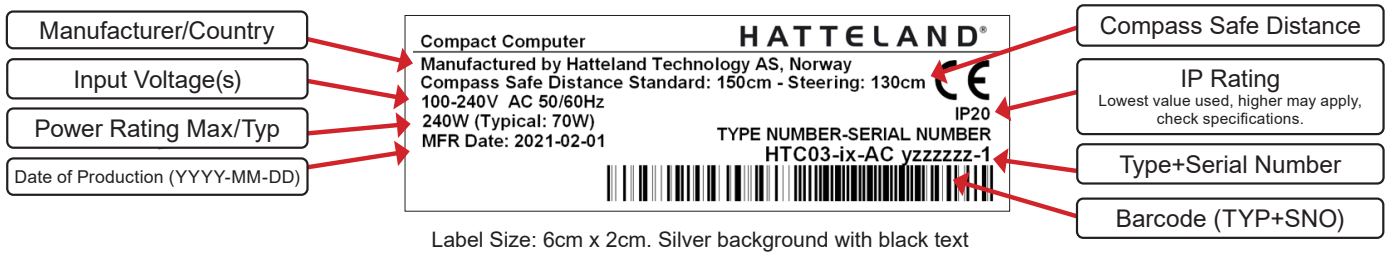

Please note that typenumber shown above is a generic sample only. May not reflect products mentioned in this manual. Please review actual product S/N label.

## Quality Control (QC) Label



This label indicates that the unit is produced, tested and packed according to the manufacture's QA specifications. It will include a Personal ID and signature by the personnel responsible for approving the unit in production, testing and warehouse departments.



# Installation



# General Installation Recommendations

## Installation and mounting of computers

1. Units may be intended for various methods of installation or mounting (rack mounting, panel mounting, bracket mounting, ceiling/wall mounting); for details, please see the relevant mechanical drawings.
2. Adequate ventilation is a necessary prerequisite for the life of the unit. The air inlet and outlet openings must definitely be kept clear; coverings which restrict ventilation are not permissible. The product might be without any ventilation apertures which means pt.2 does not apply.
3. Exposure to direct sunlight can cause a considerable increase in the temperature of the unit, and might under certain circumstances lead to overtemperature. This point should already be taken into consideration when the bridge equipment is being planned (sun shades, distance from the windows, ventilation, etc.)
4. Space necessary for ventilation, for cable inlets, for the operating procedures and for maintenance, must be provided.
5. To further improve the cooling of the unit we recommend installing Cooling Fans underneath blowing upwards into the unit air inlet. This may be required in high temperature applications and also when there is reason to expect temperature problems due to non-optimal way of mounting.
6. Products with AC input shall be grounded to protective Earth (Safety Ground) when necessary via the bolt (usually on terminal plate) available on the product.  
Products with DC input shall be grounded to protective Earth (Safety Ground) via the bolt (usually on terminal plate) available on the product. A shorter and thicker cable gives better grounding. A 6mm<sup>2</sup> is recommended, but a 4mm<sup>2</sup> or even 2.5mm<sup>2</sup> can be used for this purpose.
7. Exposure to heavy vibration and acoustic noise might under certain circumstances affect functionality and expected lifetime. This must be considered during system assembly and installation. Mounting position must be carefully selected to avoid any exposure of amplified vibration.
8. Additional rules may apply to certain procedures where the symbols  and  are present. For more information, review "IEC62368 policy for Hatteland Technology product" section later in this manual.

# General Installation Recommendations

## General mounting instructions

1. The useful life of the components of all Electronics Units generally decreases with increasing ambient temperature; it is therefore advisable to install such units in air-conditioned rooms. If there are no such facilities, these rooms must at least be dry, adequately ventilated and kept at a suitable temperature in order to prevent the formation of condensation inside the unit.
2. With most Electronic Units, cooling takes place via the surface of the casing. The cooling must not be impaired by partial covering of the unit or by installation of the unit in a confined cabinet.
3. In the area of the wheel house, the distance of each electronics unit from the magnetic standard compass or the magnetic steering compass must not be less than the permitted magnetic protection distance. This distance is measured from the centre of the magnetic system of the compass to the nearest point on the corresponding unit concerned. The exact distance is often mentioned in the specific product specifications.
4. Transportation damage, even if apparently insignificant at first glance, must immediately be examined and be reported to the freight carrier. The moment of setting-to-work of the equipment is too late, not only for reporting the damage but also for the supply of replacements.
5. The classification is only valid for approved mounting brackets provided by Hatteland Technology. The unit shall be mounted stand-alone without any devices or loose parts placed at or nearby the unit. Any other type of mounting might require test and re-classification.
6. Additional rules may apply to certain procedures where the symbols  and  are present. For more information, review "IEC62368 policy for Hatteland Technology product" section later in this manual.

## Cables

Use only high quality shielded signal cables. For RGB/DVI cables use only cables with separate coax for Red, Green and Blue.

# General Installation Recommendations



**CAUTION**  
This unit contains electrostatic sensitive devices.  
Observe precautions for handling.



## Unit Upgrade Precaution Note

Users which needs to open the unit to expose and reveal electronics, make sure that prior to touching / removing parts, proper ESD measurements must be taken!

1. Operator should ground himself by using a wrist band.
2. The wrist band should be connected to ground via a ground cord.
3. A one megaohm resistor, installed in the wrist connection end of the ground cord, is a safety requirement.
4. Hatteland Technology recommends to use an Static-dissipative ESD work mat positioned at the workplace. The 3M™ 8501 Portable Field Service Kit is a good choice for this purpose. Make sure that the mat, operator and product is wired/grounded together.

All assisting persons who might come into contact with the endangered boards must also use the ESD equipment.



## Ferrite

The ferrite prevents high frequency electrical noise (radio frequency interference) from exiting or entering the equipment. **This ferrite is required when using 100/110/115V AC voltage on the power supply (not required for 230/240V AC) to be fully compliant with type approvals.**

The ferrite should be mounted (clipped in place on the cable) and located as close as possible to the connector piece that connects to the rear of computer.

When ready: Open the ferrite, place the cable inside as shown in FIG1, and then gently close it until a click can be heard (FIG2). You may close and re-open them as many times as required during the installation.

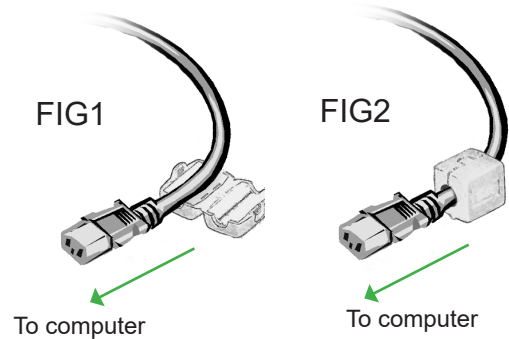

Typenumber	Ferrite Type	Dimetric View	Perferred distance of ferrite. Side view.
HTC03 xx-yy-zzzzzzz HT20370 xx-yy-zzzzzzz	1 x Würth 742 712 21		<p>Red Line indicate 5cm [1.97 inch] limit from connector. Do not mount ferrites (orange square) located beyond the red line!</p>

# General Installation Recommendations

## Housing / Terminal Block Connector Overview

Housing / Terminal Block connectors are available in different sizes (example 2-pin, 4-pin, 5-pin) which plug into the connector area of the unit. They are mounted by factory default and delivered with the unit. The housing / terminal block connectors have steering rails, which ensures that it can not be mounted wrong. The color of these connectors may vary between black, green and orange depending on manufacturer. You may use approved equivalents of these connectors, but note that the warranty will be void if any damage would occur to either the unit's original PCB terminal socket connector or inside the unit (electronic components, boards etc.). The table below is applicable for any Series X products, such as Display and Panel Computers, including newer type of Stand-Alone Computers.

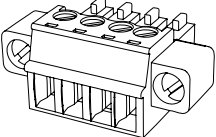
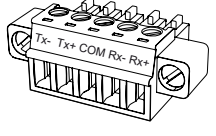
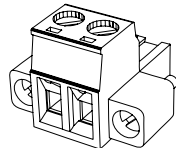
Illustration	Pins	Manufacturer Details	Connector used for module
	4-pin	BCZ 3.81/04/180F SN BK BX  Screwdriver: 0.4x2.5mm DIN 5264. Tightening torque min.. 0.2 Nm. Tightening torque max. 0.25 Nm.	• CAN Interface (ZIA0001310-B / ZIA0001310-SLCAN)  Identified on Hatteland Technology product datasheet as: "Terminal Block 3.81"
	5-pin	MC 1,5/ 5-STF-3,81 Screwdriver: SZS 0,4X2,5mm VDE, slot-headed.  Tightening torque min. 0.22 Nm. Tightening torque max 0.25 Nm.	• RS-422 / RS-485 NMEA (PCA200828-1 / PCA100293-1) • Digital Input/Output (PCA100297-1)  Identified on Hatteland Technology product datasheet as: "Terminal Block 3.81"
	2-pin	MSTB 2,5/ 2-STF-5,08 BK  Screwdriver: SZS 0,6x3,5, slot-headed. Tightening torque min. 0.5 Nm. Tightening torque max 0.6 Nm.	• DC Power IN - Single Input  Identified on Hatteland Technology product datasheet as: "Terminal Block 5.08"

If your installation require additional cable fasteners support, please use the provided Cover Hood and Cable Housing shipped with the unit for accessories (contents of package). Illustrations below are approximate, actual Housing and Hood may deviate slightly, but function remains the same.

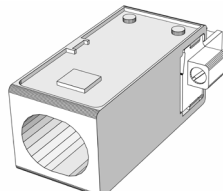
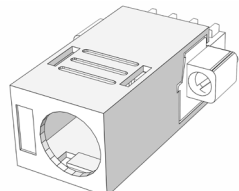
5-pin Cable Housing - Illustration	4-pin Cover Hood - Illustration
	
KGG-MC 1,5/ 5 (5-pin)	BCZ 3.81 AH04 BK BX (4-pin)
For 5-pin: <a href="https://www.phoenixcontact.com/online/portal/us?uri=pxc-oc-itemdetail:pid=1834372&amp;library=usen&amp;pcck=P-11-02-01&amp;tab=1">https://www.phoenixcontact.com/online/portal/us?uri=pxc-oc-itemdetail:pid=1834372&amp;library=usen&amp;pcck=P-11-02-01&amp;tab=1</a>	
For 4-pin: <a href="http://catalog.weidmueller.com/procat/Product.jsp;jsessionid=B040D5EB6832629E567C884809FDF6C1?productId=(%5b1005290000%5d)">http://catalog.weidmueller.com/procat/Product.jsp;jsessionid=B040D5EB6832629E567C884809FDF6C1?productId=(%5b1005290000%5d)</a>	



# General Installation Recommendations

## Configuring Housing / Terminal Block connectors

Below is a brief illustration that might be useful during configuration and installation of such connectors. You will need suitable pre-configured cable(s) and tools to configure the connector(s) and cable(s) that are present in your installation environment. Below is a sample procedure for a 2-pin DC power connector. The procedure is the same for other connectors of this type as listed in table above. Unit used as illustration below is for reference only.

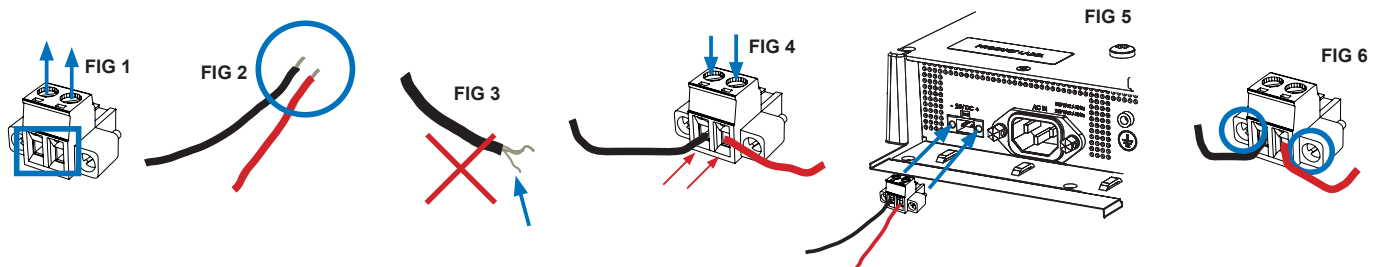

**Requires assembly. It is expected that the technician has experience in electronics and assembling cables and connectors.**

**Warning:** Do not connect or disconnect cables/connectors to the unit's connector while the unit is powered on. Failure to do so may result in damaged electronics.

**FIG 1:** Unscrew (from top) or make sure that the screw terminal is fully open, so you can secure the inserted cables correctly to the loose housing connector (it may already be plugged into the unit as per factory installation).

**FIG 2:** Strip carefully the insulation from the cable to expose the wire(s) inside.

**FIG 3:** Ensure that the wire(s) is without any loose threads to ensure good connection.

**FIG 4:** Insert cables\* (from front) and screw / secure the cables by turning the screw on top of the housing to secure the cables properly. Check that the cables are firmly in place and do not appear loose or fall out when pulling gently.

*\*Note: Required polarization verification (for instance -/+ for DC power input) should conform with the markings on the connector area of the unit. Ignoring the markings on the unit or its add-on modules might damage the unit and/or external equipment in which end, warranty will be void.*

**FIG 5:** Plug the housing into the appropriate connector area of the unit and check again that the cables secured conform with the markings on the connector area of the unit. Finalize the installation by fastening the screws located in front on each side of the housing connector (**FIG 6**).

Connector / Function	Recommended Cable Thickness
2-pin DC Power Input (Terminal Block 5.08)	Minimum 20 AWG - Maximum 18 AWG
4-pin CAN (Terminal Block 3.81)	Minimum 22 AWG - Maximum 20 AWG
5-pin NMEA COM (Terminal Block 3.81)	Minimum 22 AWG - Maximum 18 AWG
5-pin DIO (Terminal Block 3.81)	Minimum 22 AWG - Maximum 18 AWG



## Cabinet cover removal

Note: Areas of interest are marked in this section with arrows in **RED** color. Please disconnect ALL cables from the computer unit before proceeding! Procedure applies for all HTC03 models.

1: Unscrew 20 screws (M3x5L S/S) from top of cabinet and 3 screws (M3x5L S/S) in rear. Use a Torx 9 screwdriver.

2: Lift the cover up with both hands.

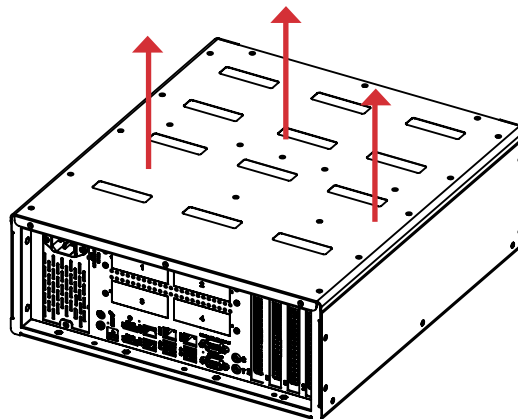
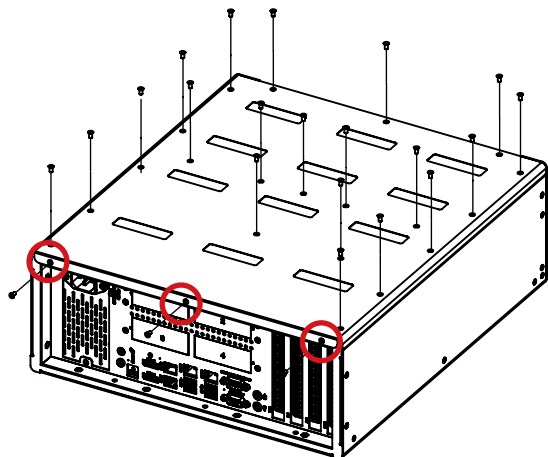

3: The inside of the computer is now revealed.

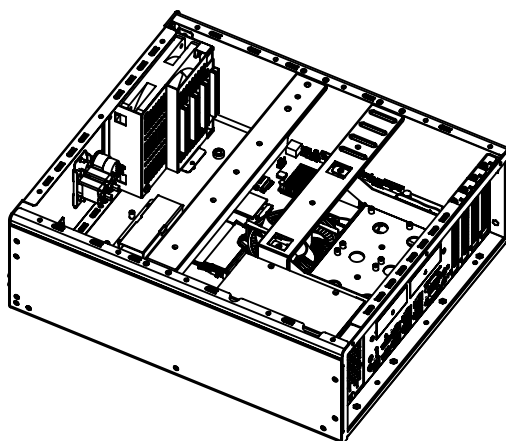

Repeat the procedure backwards to attach the cover again.



## Installing PCIe Card / Rework PCI Bracket Options - Notice

All factory options are done in-house by our production facility prior to delivery. If you however need to install your own PCI/PCIe cards later and any of the PCI Bracket Options are already pre-installed, please review: *“Physical Connections/ Added functionality through 4 x PCI Sized Metal Brackets”* chapter later in this manual.

As this is just a pre-installation notice, please review also the next following page regarding PCI/PCIe card installation. Procedure applies for all HTC03 models.

Note: Areas of interest are marked in this section with **RED** color. Please disconnect ALL cables from the computer unit before proceeding!

1: Identify if either of the PCI Bracket Options are present in any of the slots (as indicated). If yes, proceed to step 2,3,4. If no, please proceed to next page in this manual.

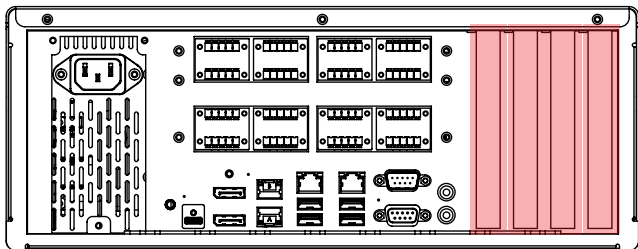

2: Observe the tie wrap and positioning of cables. You may have to cut the tie-wrap that holds the cable to the inner chassis, in order to insert the new PCIe card and fit the cable again.

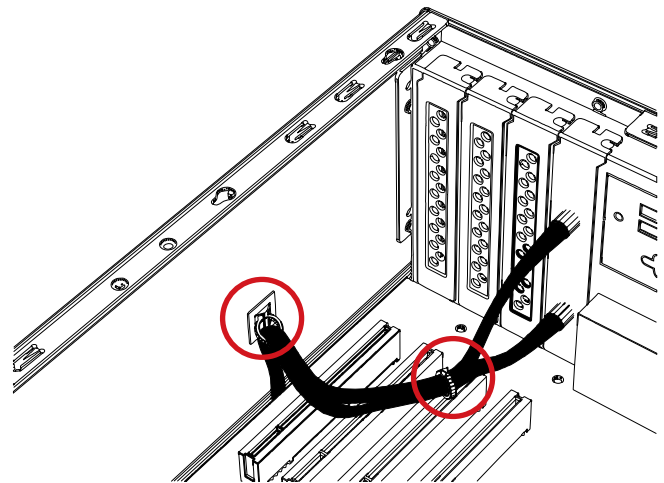

3: Either move the PCI Bracket Option into any of the other free slots, or make sure the original cables are routed under the PCIe card when you install the new PCIe card (depending on which slot you have to use).

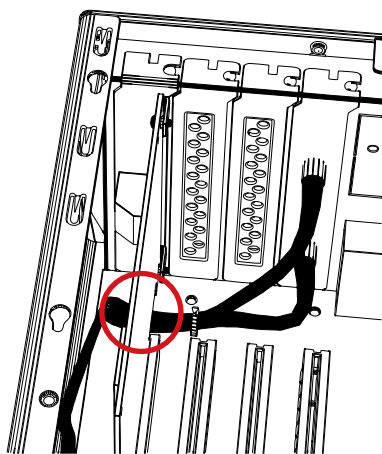

4: After installing the PCIe card, observe that the PCI Bracket Options cables are not damaged, loose or are subject for getting damaged after long use. Notice also some PCIe card components may get hot. If possible, add a tie wrap to secure the cables further to keep clear of potential heat.

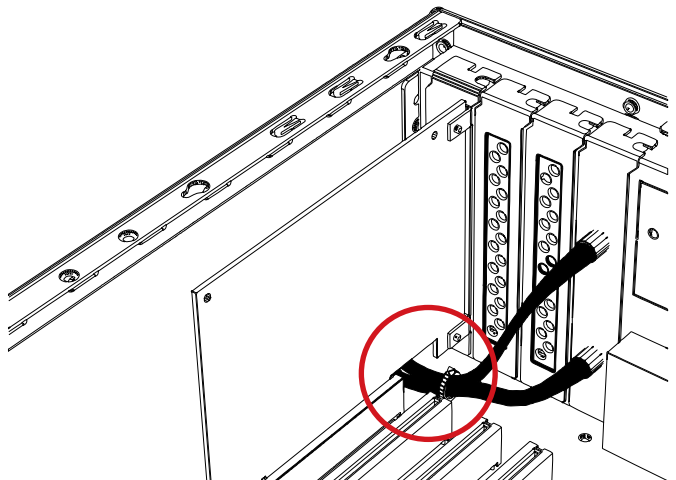



## PCIe Card removal / replacement - Introduction

Note: Areas of interest are marked in this section with circles and arrows in **RED** color. Please disconnect ALL cables from the computer unit before proceeding! Procedure applies for all HTC03 models.

1: Unscrew 10 screws on each side of the top brackets. Use a Torx 9 screwdriver.

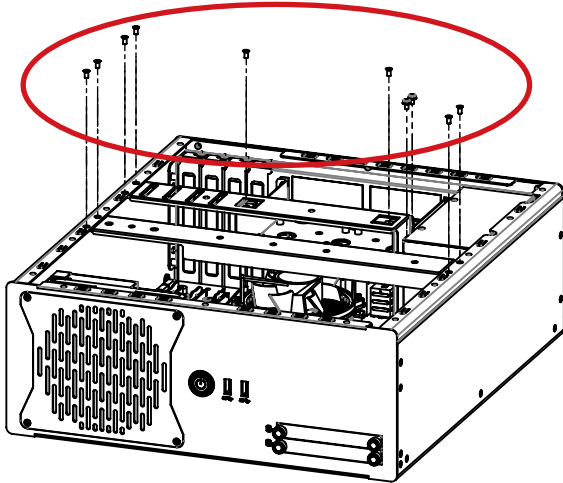

2: Push each side of the top bracket, one forward and one backwards in a 45 degree rotation clockwise to slide it out of the tracks. Then lift up the top bracket to remove it.

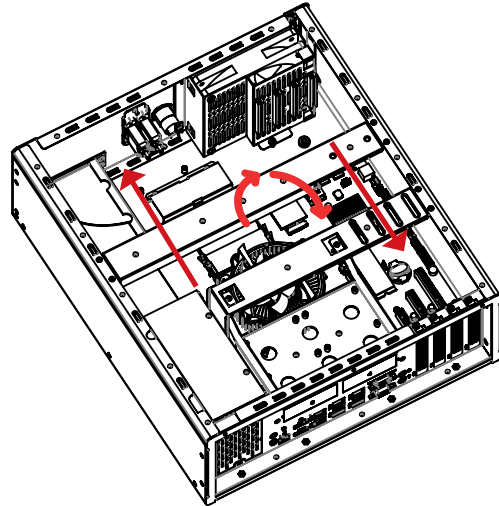

## PCIe Card removal / replacement

Note: Areas of interest are marked in this section with circles and arrows in **RED** color. Please disconnect ALL cables from the computer unit before proceeding! Procedure applies for all HTC03 models.

1: Unscrew 1 screw to loosen the chosen PCIe card bracket from the cabinet and remove or insert the desired PCIe card into the slot. Use a Pozidriv #2 screwdriver.

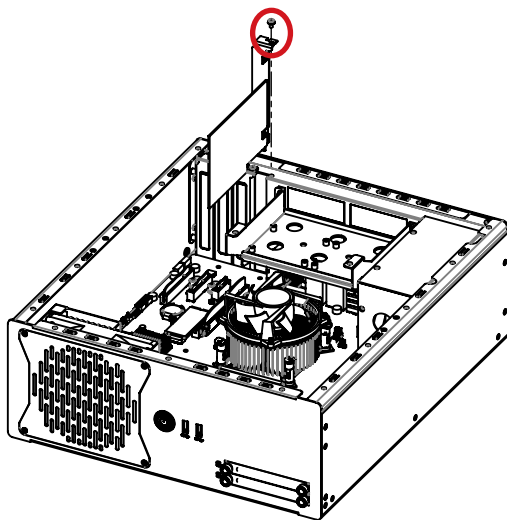

2: Attach the internal bracket over the PCIe card and re-mount the 10 x screws to fasten the internal bracket and secure the PCIe card.

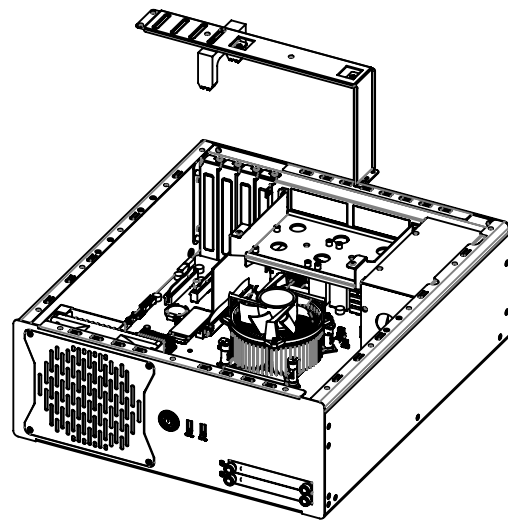

Repeat the procedure backwards to finalize operation.



## HT 00275OPT-A1 (PCIe Card Bracket, Removal & Replacement) HL/FL/HH

Note: Areas of interest are marked in this section with circles and arrows in **RED** color. Please disconnect ALL cables from the computer unit before proceeding! Procedure applies for HTC03 models.

### For Half Length (HL) + Full Length (FL) / Half Height (HH) - PCIe cards

Place the EN60945 Tested Bracket as shown on top edge of card and under the top bracket. Mount 2 x M3x6mm Countersunk screws on top to fasten the PCIe bracket securely. Use a Pozidriv #2 screwdriver.

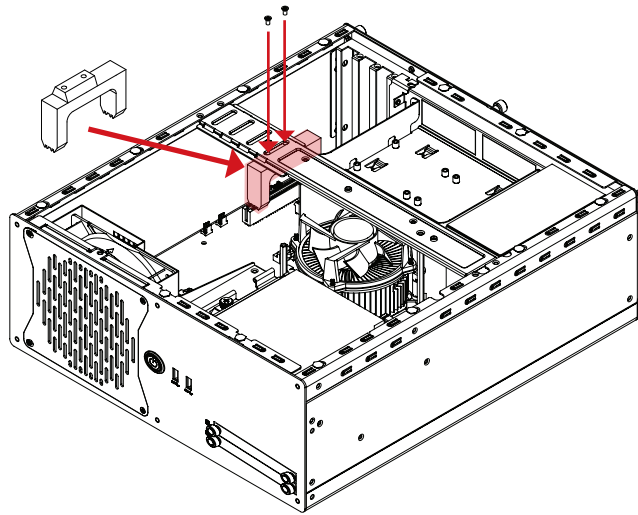



## Air Filter removal / replacement (H733S30Q20-SP000-0)

Note: Areas of interest are marked in this section with circles and arrows in **RED** color. Please disconnect ALL cables from the computer unit and cards before proceeding! Procedure applies for all HTC03 models.

1: Unscrew 4 screws from the fan/filter cover in front of the unit. Use a Torx 9 screwdriver.

2: Gently pull out the fan/filter cover and filter

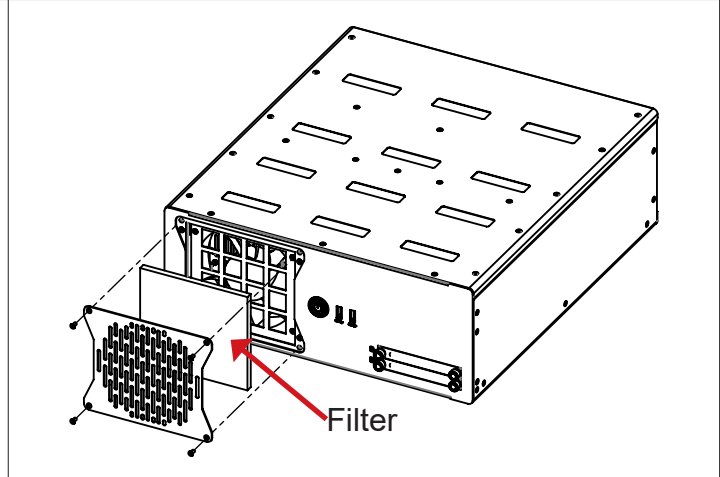
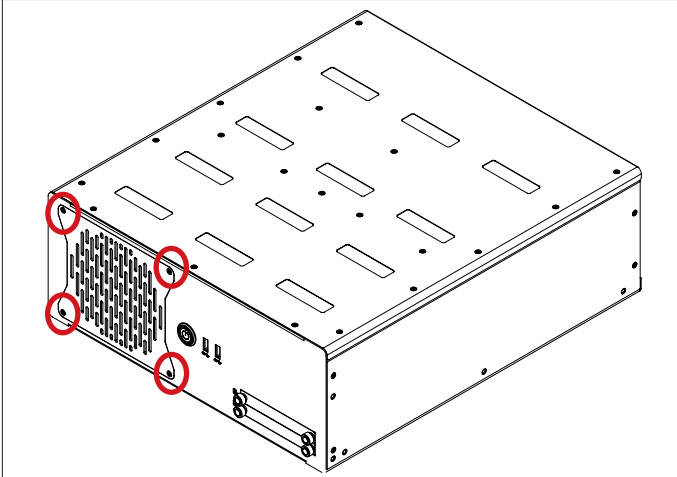

Repeat the procedure backwards to finalize operation.



## Front Fan removal / replacement

Note: Areas of interest are marked in this section with circles and arrows in **RED** color. Please disconnect ALL cables from the computer unit before proceeding! Procedure applies for all HTC03 models.

1: Remove cabinet cover then unscrew 1 screw from the back of the fan cover inside the computer to loosen the fan and fan cover. Use a Pozidriv #2 screwdriver.

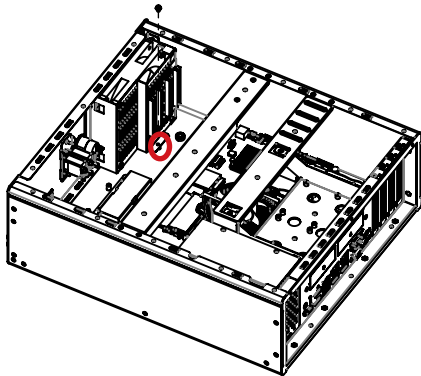

2: Remove fan/filter cover (see beginning of this chapter) Then unscrew 4 screws from the fan/filter cover location in front of the unit. Use a Torx 9 screwdriver.

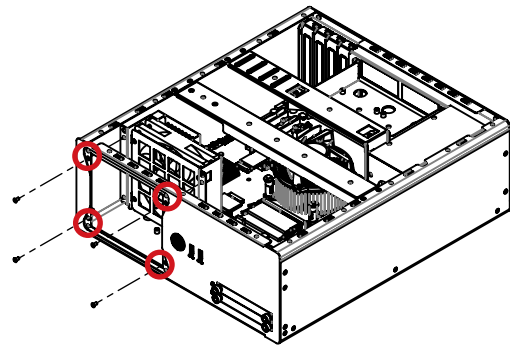

3: Unscrew 4 screws from the fan cover and unplug the fan. Use a Pozidriv #2 screwdriver.

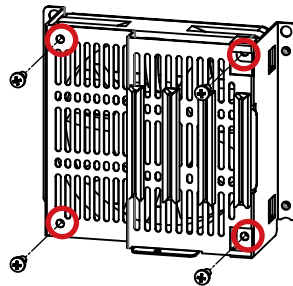

Repeat the procedure backwards to finalize operation.



## Mounting Bracket Kit (Desktop) HTC03

Mounting Bracket Kit (HT MBK STD-C1: Mounting Bracket Kit HTC03/HTC04 - L-Shaped).

Note: Areas of interest are marked in this section with **RED** color.

Note: In order to secure the unit properly, please use only the screws delivered with the unit. Choosing own screws and longer than factory specified may cause permanent damage inside the unit and Warranty will be void !

▼ 1: Place the complete unit onto your desired location and mark the positions you need to drill. The drilling hole should be M5. The space under the location should allow for M5 locking nuts. Max thickness of mounting area/plate is 8mm. If your mounting area/plate is thicker, please assure you acquire longer screws specified as "M5x20 or larger Unbrako DIN912 Black". View below is TOP VIEW.

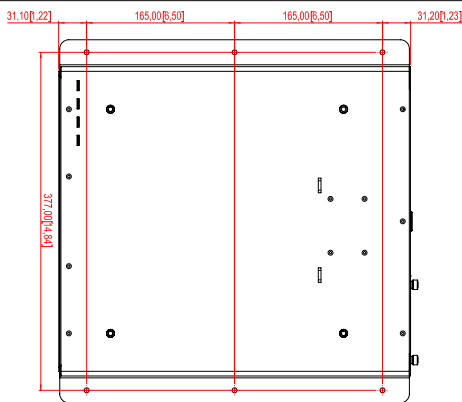

▼ 2: Prepare the brackets, one on each side of the unit as indicated. Make sure the bracket is rotated correctly by aligning as red line show below.

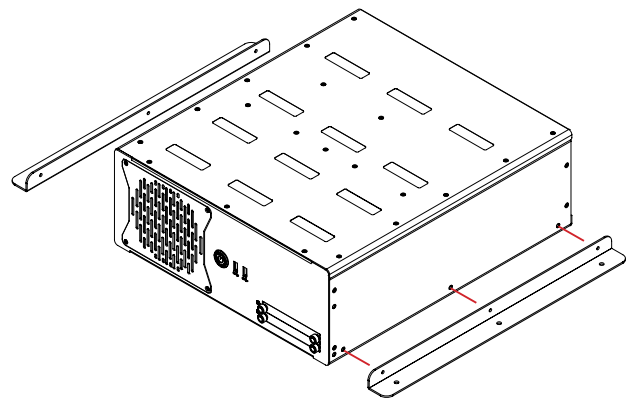

▼ 3: Mount each bracket onto lower part of unit, using 3 pcs M4x8 Black Torx DIN7046 on each side of the unit. Use Torque Force: 2.0 Nm

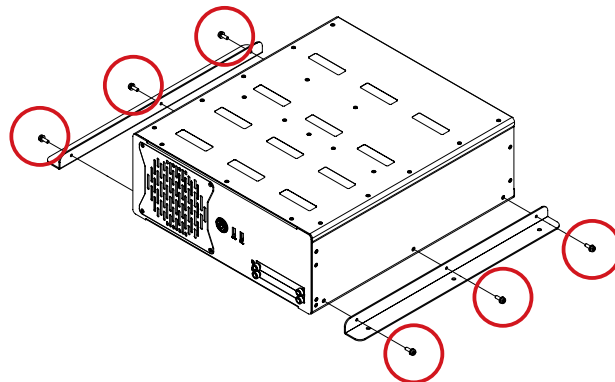





## Mounting Brackets for Console Mounting - HT 00226 OPT-A1

Note: The unit comes with mounting brackets and screws for console mounting in the package. Please review specifications and “Technical Drawings - Accessories” chapter in this user manual for additional information. Procedure applies for all HTC03 models.

### Bracket View and Measurements

### 1: Bottom view showing 4 mounting holes.

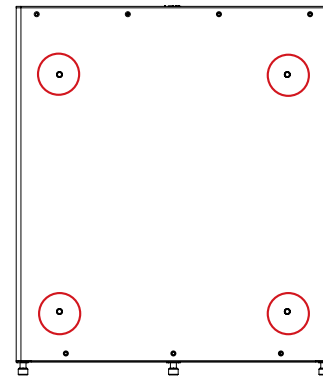
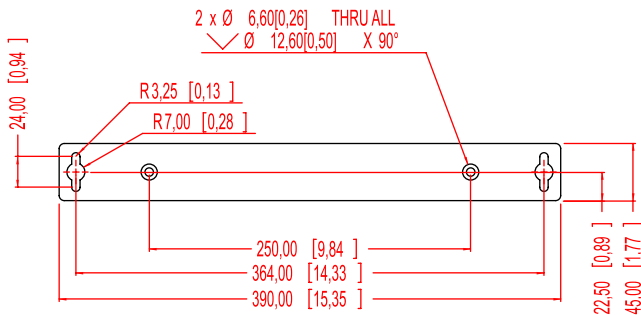

Connector Side

### 2: Mount the brackets with 4 x M6x8 (included).

**Note: Other/longer screws may damage the computer!**

### 3: Bottom view with mounted brackets.

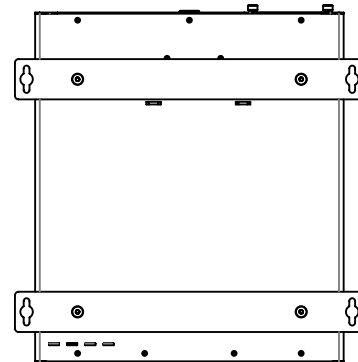
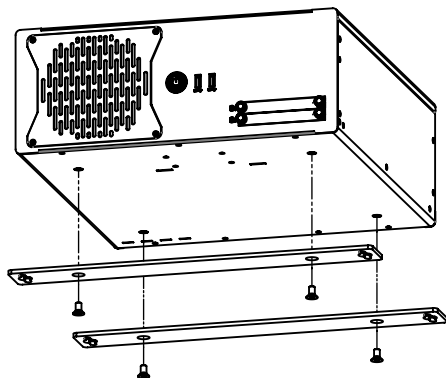



## 19 inch Rack Kit 4U - HT 00223 OPT-A1

Note: The unit can also be mounted inside a Hatteland Technology 4U cabinet for rack mounting purposes. Please review specifications and “Technical Drawings - Accessories” chapter in this user manual for additional information. Procedure applies for all HTC03 models.

1: Empty 4U cabinet suitable for the computer and final solution (note that there is no 4U top cover, as the HTC03 model has its own already).

2: Showing mounting and screw (included) positions.  
 A = 4 Panhead M6 x 8 (mounted from under)  
 B = 4 Countersunk M4 x 8 (4 on each side)

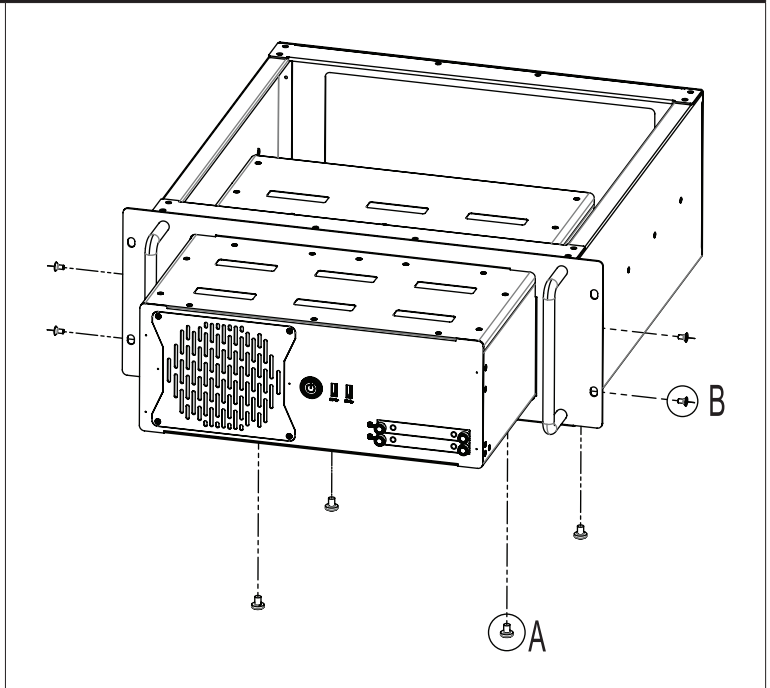
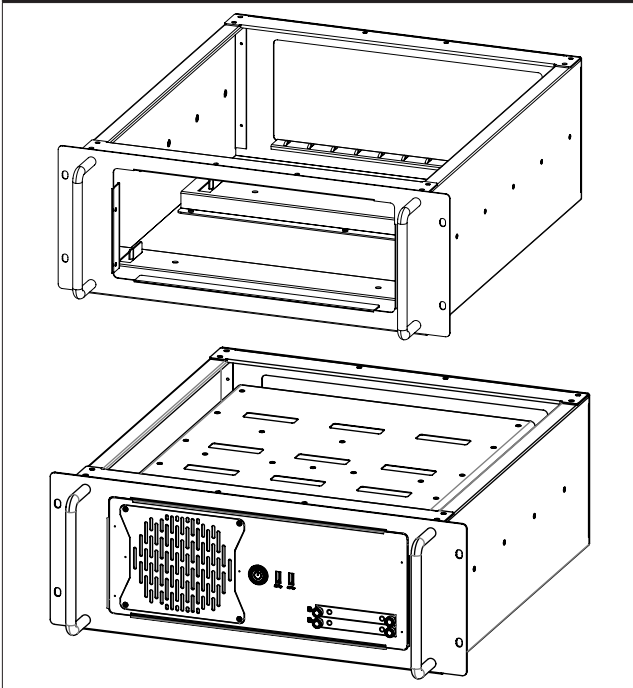

## Sliding Rails - HT 00224 OPT-A1 (20”) / HT 00225 OPT-A1 (26”)

Note: The 19 inch Rack Kit 4U can also be mounted with sliding rails (20” or 26”). Please review specific drawings in this user manual for suitable holes and measurements / 3rd party mounting instructions found in the Sliding Rails package. Procedure applies for all HTC03 models.

HT 00224 OPT-A1 (20” rails)

HT 00225 OPT-A1 (26” rails)

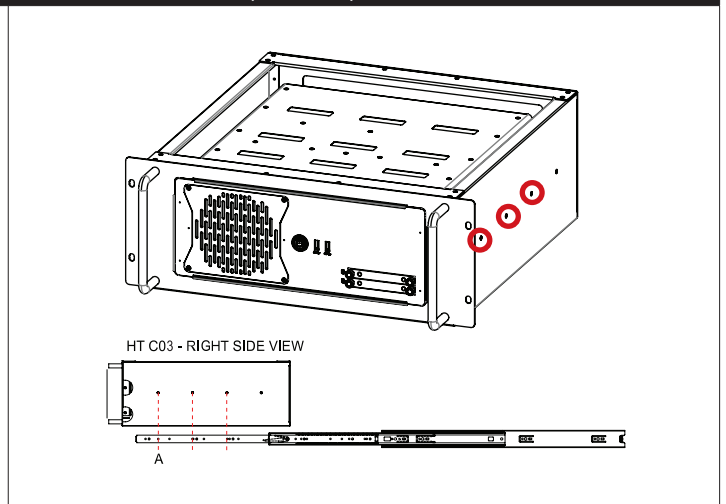
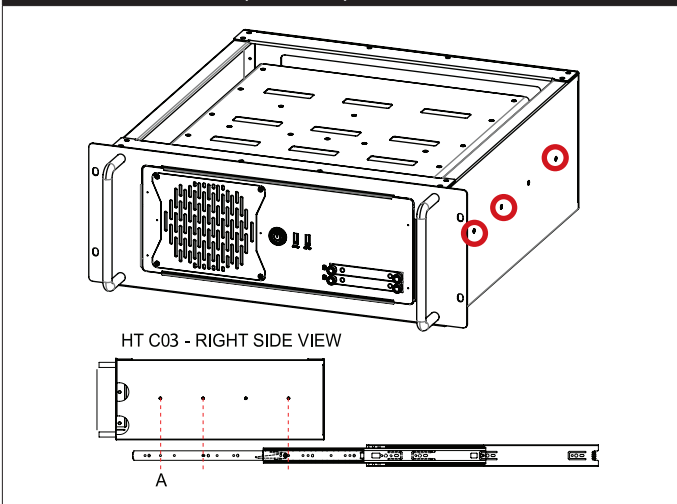



## Examples of mounting orientations to avoid

In accordance with the IEC 62638-1 New Safety Standard, the following mounting orientations of the unit below, is not recommended by Hatteland Technology.

▼ 1: On wall, connectors facing up or down, even with external fan pushing away heat. Inside or outside of cabinet does not matter.

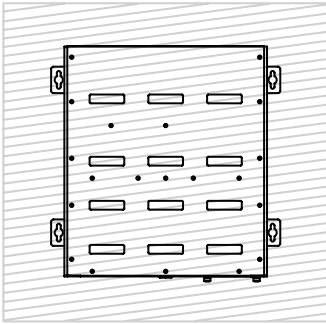

▼ 2: On wall, connectors facing left or right, even with external fan pushing away heat. Inside or outside of cabinet does not matter.

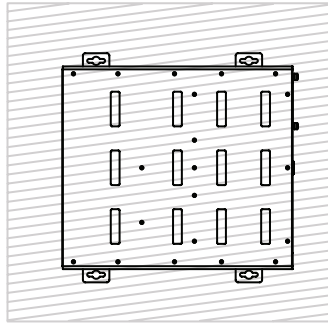

▼ 3: Ceiling based or upside down, even with external fan pushing away heat. Inside or outside of cabinet does not matter.

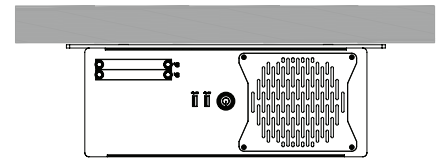



## Replacing Internal CMOS/BIOS Battery

Note: Areas of interest are marked in this section with arrows in **RED** color. Please disconnect ALL cables from the computer unit before proceeding! Procedure applies for all HTC03 models.

Please review "Product Storage" recommendations document, ref:

[https://www.hattelandtechnology.com/hubfs/pdf/misc/ind100350-5\\_long\\_term\\_storage\\_recommendations.pdf](https://www.hattelandtechnology.com/hubfs/pdf/misc/ind100350-5_long_term_storage_recommendations.pdf)

**NOTE: All BIOS settings, Date and Time will be lost if battery is removed from motherboard.** If Factory Default BIOS settings was changed after unit was received from factory, please write down changes (if known) before doing this procedure. Operating System installed will not be affected by a battery replacement. After battery was replaced and unit powered, check BIOS settings and choose to load Factory Default Settings, change time and date. BIOS Settings and its adjustment are outside the scope of this chapter in User Manual. Consult your experienced technician or contact our service / support channels worldwide for further assistance if unit does not operate as intended.

1: Unscrew 20 screws from top of cabinet and 3 screws in rear. Use a Pozidriv #2 screwdriver.

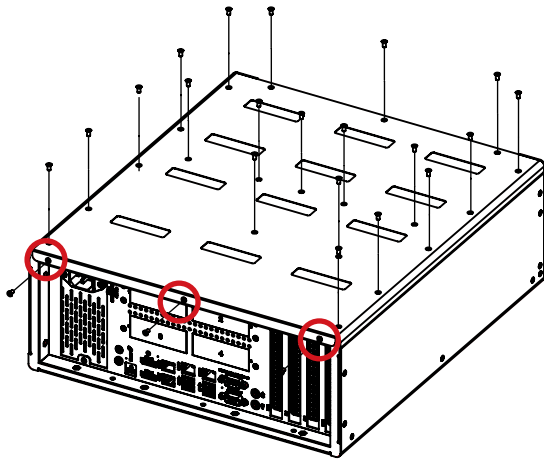

2: Lift the cover up with both hands.

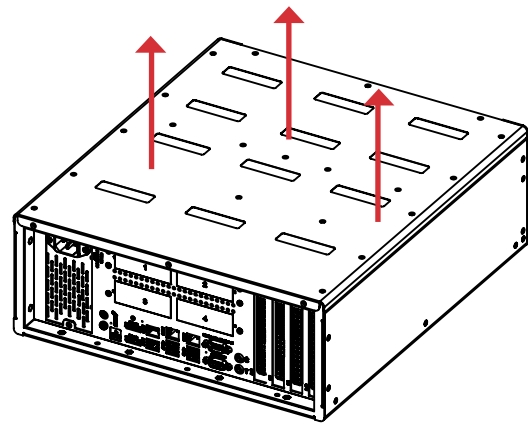

3: Locate CMOS battery as indicated near the smallest PCI-E slot (just above it).

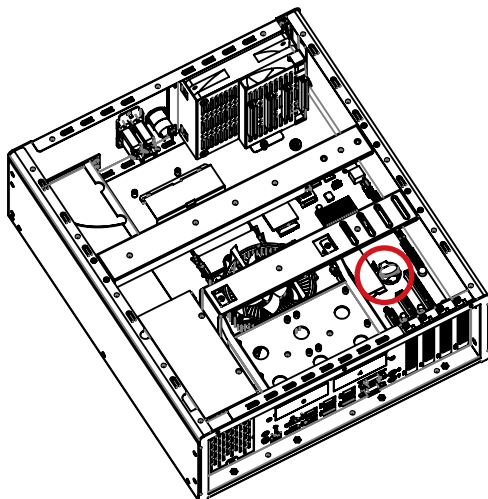

4: With a finger/nail, push the metal clip inwards as indicated (1) and the battery will pop up automatically (2).

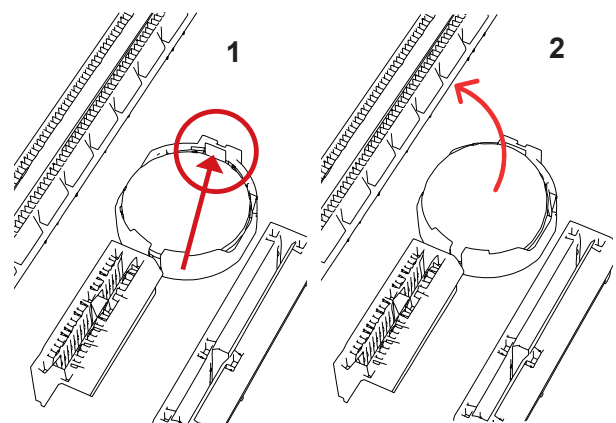



5: Carefully grab the battery with finger/nail and remove it from the holder.

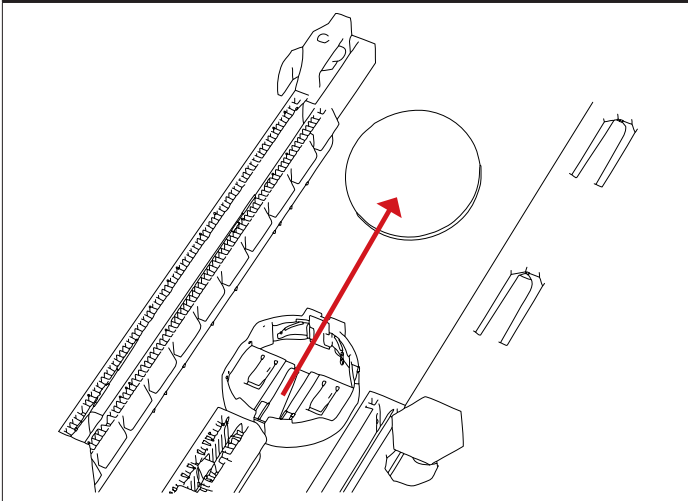

6: Place the NEW battery as aligned in the lower part first. Viewed in opposite direction below.

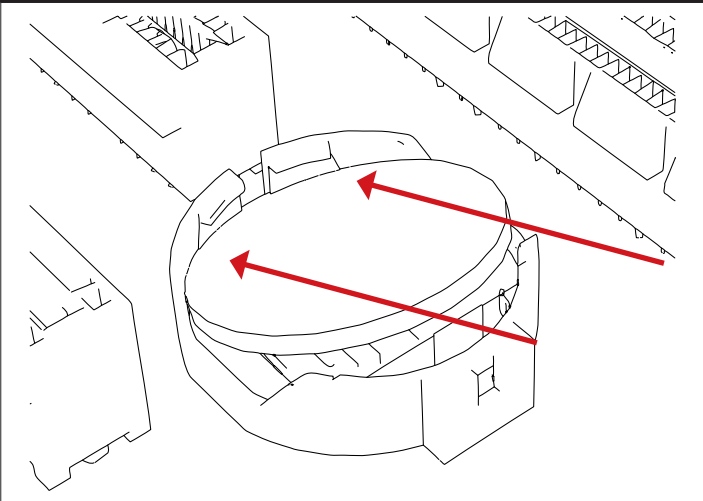

7: Finally push the battery down with thumb/finger (1) until it is reseated flat vertically and a metallic click sound is heard (2).

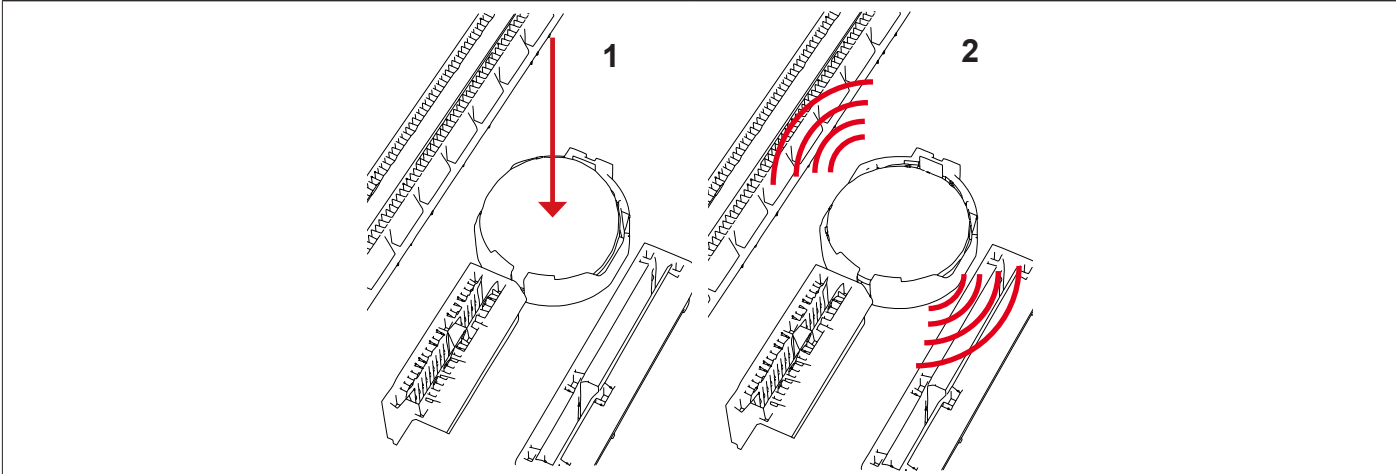

Repeat the procedure backwards to finalize operation (step 2 to 1).

## Front area of computer models

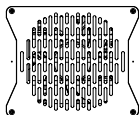
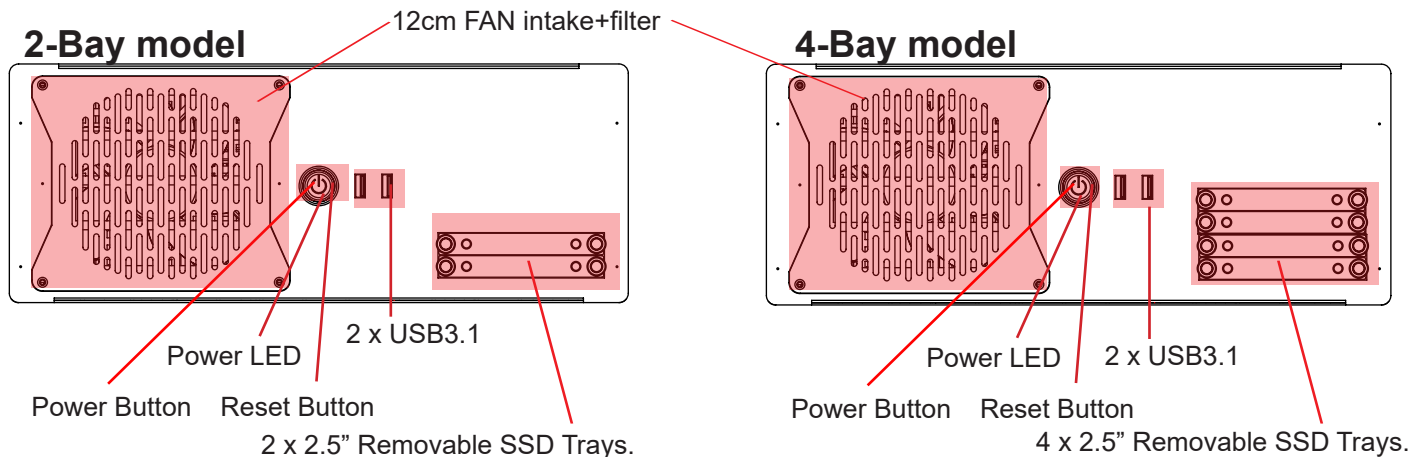

### AIR FILTER:

The computer unit features an cleanable / replaceable air filter (H733S30Q20-SP000-0) located in front behind the metal hatch. Clean the filter regularly or change it (based on environmental factors) to allow the unit to continuously cool properly and to prolong the unit's lifetime and the components inside. Please review Installation Chapter earlier in this manual for instructions. Spare Part Air Filter can be ordered, check Data Sheet in this manual..



### 2 x FRONT USB3.1 (<3m) INPUT/OUTPUT:

Supports any USB1.1 (12Mbps), USB2.0 (480Mbps) or USB3.1 (10Gbps) compliant peripherals. Drivers for most USB devices are usually included in operating system or on separate installation CD's delivered with Third Party products. USB 1.1 devices will operate in USB 1.1 mode (12 Mbps) and USB 2.0 devices will operate in USB2.0 mode (480Mbps).



### Power/Reset Combined Button:

To turn ON the computer, press down button and release it immediately. The Power LED indication ring will illuminate green and the operating system will automatically boot. To turn OFF the computer, press down this button and hold it for 3 seconds. The operating system may require additionally tasks to be performed before computer shuts down and turns off the unit.

To reset the computer in case of severe software failure, press this button. This reset button is a hard reset which means the operating system will NOT be warned. Using this reset method may damage files and / or operating system in worst case scenarios. Precaution should be taken when using this. To perform a safe software reset, press either the power button, or use the operating system own reset functionality if possible.

The Power LED Indication will illuminate static green when powered on. When power is off and the unit is turned off, the LED will also off.

# User Controls

## 2 x 2.5" Removable SATA SSD Trays (only Standard model):

The unit can utilize 2 x Storage Devices (SSD), 2.5" size. (1 x tray is by factory default occupied, **Device #0**). The storage devices can be easily be upgraded or replaced by pulling the SSD tray out.

Both trays feature a locking mechanism (using quarter-turn fasteners to lock/unlock) function to prevent accidental removal and to secure the device additionally.

### How to Remove or Replace SSD Device

The unit must be shut down / powered off before proceeding. After unlocking the tray by unscrewing the thumbscrews (FIG 1) pull out the tray carefully by hand (FIG 2), please proceed as illustrated below.

**FIG 1**

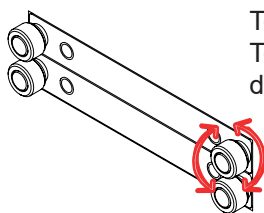
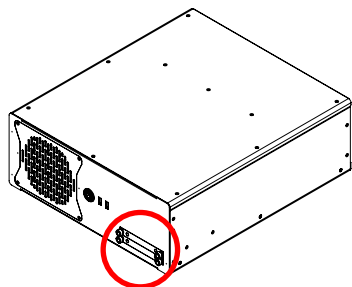

Locked/unlocked by quarter-turn fasteners with springs.  
To unlock, turn 90 degrees anti-clockwise.  
To lock, push the quarter-turn fastener in and turn 90 degrees clockwise.

**FIG 2**

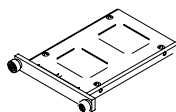
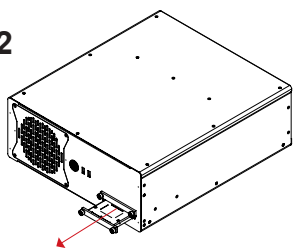

Pull out the casing gently as indicated. The tray shown here does not have a Storage Device already in-place.

Single Front Removable Tray and Pre-mounted Storage Device are available from Hatteland Technology as accessory.

**Typenumber** : HD xxxyy SX1-z1  
**Where x =** : Size  
**Where y =** : MB, GB, TB  
**Where z =** : Physical Format / Device Type  
(Physical Format examples: 2.5")  
(Device Type examples: SSD)

Please review datasheet for your model to determine Size, Format and Device Type compatible with your model.

or Empty Front Removable Tray 2.5" (without screws):

**Typenumber** : HD 000TR SX1-A1

or Empty Front Removable Tray 2.5"

+ 4 x M3x4mm Phillips Countersunk Screws:

**Typenumber** : HD 000TR SX1-A3

**FIG 3**

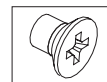
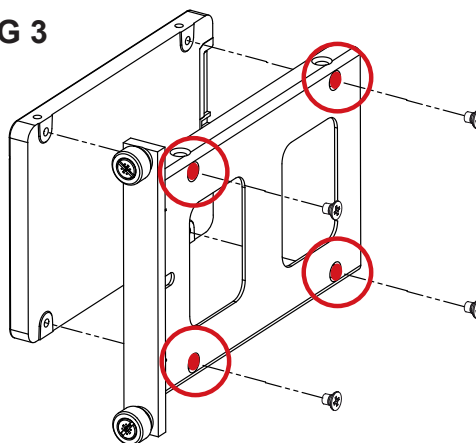

Unscrew 4 pcs x M3x4mm Phillips countersunk screws as indicated. Replace or remove the device as needed. Make sure the device connects with the interface connector located in the end of the tray prior to fastening screws.

Screwdriver: Philips PH2

Tightening torque 0.4Nm.

Repeat the procedure in reverse (FIG3-2-1) to mount.

### FIG 4 (Optional)

Extra locking mechanism inside computer to prevent SSD(s) from being removed unintentionally or by unauthorized personnel. Not mounted by Factory default.

See Cabinet cover removal procedure in General Installation Recommendations chapter for instructions on how to remove the Cabinet cover.

To lock SSD(s) in place, add and mount M3 screw(s) as indicated. Follow SSD manufacturer's instructions for screw length and torque.

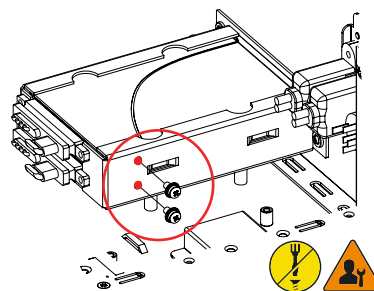



# Physical Connections

## Connector area of computer - Single AC power input model

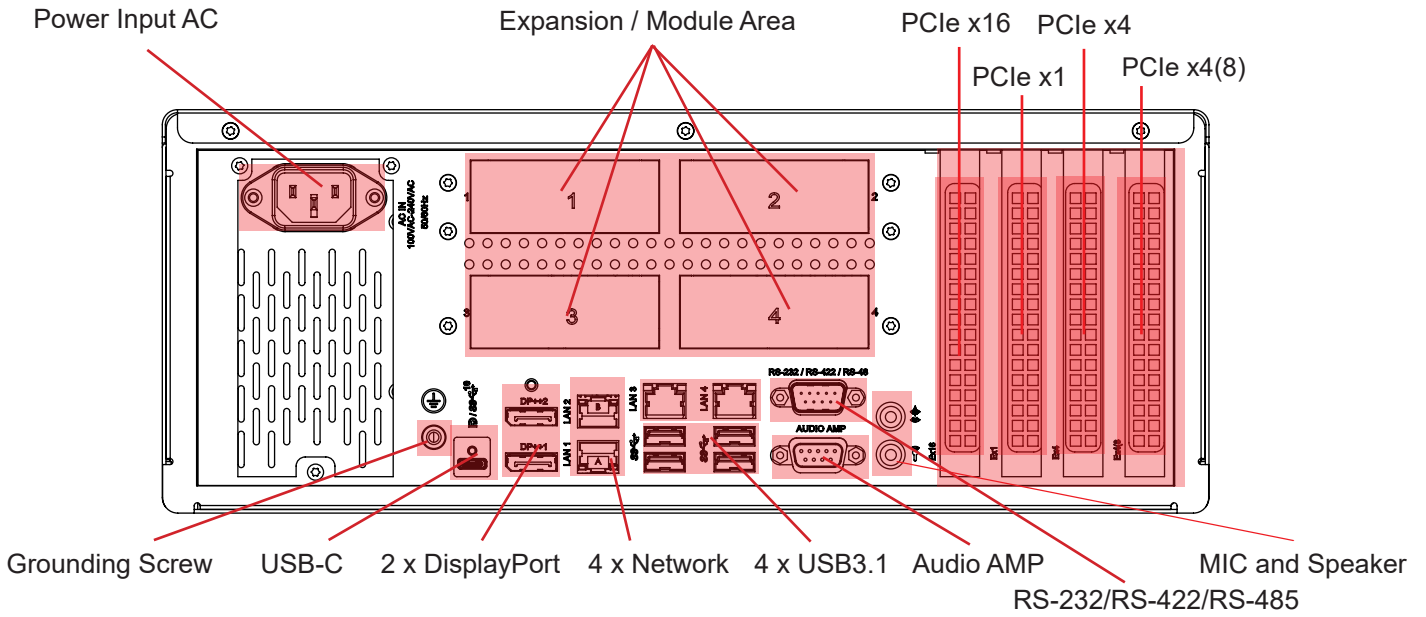

## Connector area of computer - Multi-Power (AC+DC) power input model

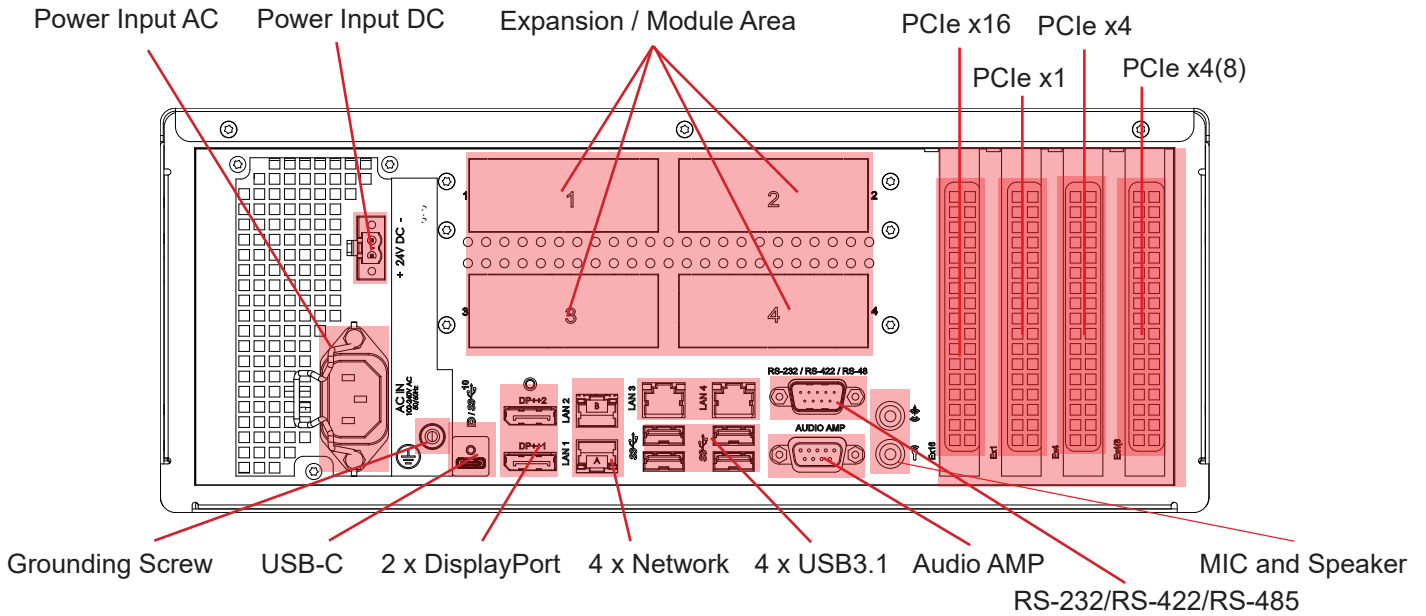



## User Controls / Physical Connections

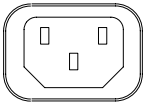

### 1 x AC Power INPUT (For units supporting AC input):

The internal AC power module supports 100-240V AC - 50Hz/60Hz using a standard IEC European power plug. See specifications for more information.

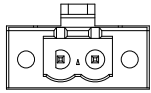

+ 24V DC -

### 1 x DC Power INPUT (For units supporting AC+DC inputs):

Connect your DC power cable to the 2-pin Terminal Block 5.08 connector. The internal DC power module supports 24VDC. For more information, please review "Housing Connector Overview" earlier in this manual.



### GROUNDING SCREW:

Please review "General Installation Chapter", pt. 6 for more information.

Note for Grounding Screws: Standard Grounding Screw/Bolt provided by Hatteland Technology is "Pan head screws M4x8mm w/spring and plainwasher".

### Multi-power note: (For units supporting AC & DC input simultaneously)

*The unit has a dual input power supply which will accept both AC and DC input. If both inputs are connected, the unit will be powered by AC. If AC is disconnected it will automatically switch over to DC without affecting the operation of the unit. This makes it possible to use AC power as primary power and a 24V battery as secondary power, eliminating the need for expensive UPS systems.*

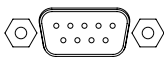

### 1 x COM (RS-232/422/485) Serial Port INPUT/OUTPUT:

Supports RS-232 or RS-485/422 using D-SUB 9P connector (male) connectors. Fasten the cable to the connector using the provided screws on the cable housing itself. For configuration, please review the Appendix chapter, section "BIOS - On-board COM Ports Configuration".

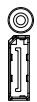

### 2 x DisplayPort (DP) OUTPUT:

Connect your DP (male) cable to the DisplayPort (v1.2) 20P connector (female) on the rear side of the unit. The DP has its own locking mechanism that locks the plug inserted. Make sure the plug "clicks" into place to verify a proper and secure connection. Additionally to add extra security, a Screw Lock in the chassis above the DP port is available if your DP cable supports it.

**Note:** Signal Output can be used together with additional graphics card installed in one of the PCIe slots. Please review Appendix Chapter "BIOS - Hybrid Multi Monitor Configuration". Both active and passive DP to DVI adapters are supported. For setups requiring three DVI-D outputs, an active DP to DVI adapter must be used. Passive adapter can only be used for setups with max two DVI-D signals.

# Physical Connections

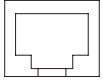

## **4 x Network INPUT/OUTPUT:**

Supports 10/100/1000Mbps Ethernet (LAN) through either 2 x Intel® or 2 x Realtek driver based. All 4 LAN connectors can be used at the same time. Suitable for twisted pair cables CAT.5E. Make sure the network cable connector "clicks" into the RJ-45 connectors.



## **4 x USB3.1 REAR INPUT/OUTPUT:**

Supports both USB1.1/2.0 compliant peripherals (backward compatibility mode) including the newer USB3.0 (10Gbps, <3.0m) protocol for increased data bandwidth. Drivers for most USB devices are usually included in operating system or on separate installation CD's delivered with Third Party products. For most stable operation, only USB3.0 specific external compliant peripherals should be connected to these ports, as some USB1.1/2.0 devices may not be fully compatible. Local testing of USB1.1/2.0 equipment connected to these ports should otherwise be performed.

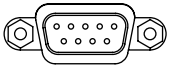

## **1 x AMPLIFIED AUDIO OUT:**

Offers 2W Amplified Mono/Stereo Audio Out via 1 x DSUB 9P Female connector, please refer to Pinout Assignments chapter for more information.



## **2 x Audio mini-Jack INPUT/OUTPUT:**

Both connectors are 3.5" Jack Stereo. Realtek HD Audio supports 2.0 channel, function as Stereo Line Out and Stereo MIC In.

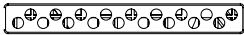

## 4 x PCIe Slots:

Supports Full Height and Full Length Profile cards. Cards are normally installed from factory. Please review the General Installation Recommendations chapter in this manual for more information.

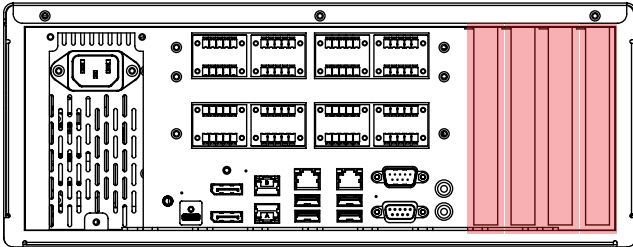

## Available PCIe based card options:

Illustration Module	Description / Function	Compatible Slots
	NVIDIA® P2200 Low Profile, 5GB Graphics Card Connectors: 4 x Displayport (Female) Typenumber: PNY NVIDIA Quadro P2200	PCIe x16
	NVIDIA® P620 Full Height (FH), Half Length (HL) 2GB Graphics Card Connectors: 4 x miniDP (DisplayPort) Female Typenumber: PNY NVIDIA Quadro P620	PCIe x16
	Intel® Network Adapter (10GbE) Connectors: 2 x RJ-45 Typenumber: X710T2LBLK	PCIe x16 PCIe x4
	Intel® Network Adapter (1GbE) Connectors: 2 x RJ-45 Typenumber: I350T2V2BLK	PCIe x16 PCIe x4
	Intel® Fiber Network Adapter (10GbE) Connectors: 2 x SFP+ Typenumber: X722DA2	PCIe x16 or PCIe x4
	Intel® Fiber Network Adapter (1GbE) Connectors: 2 x LC Fiber Optic Typenumber: I350F2BLK	PCIe x16 or PCIe x4
	Serial Communication COM 4 Ports Isolated, RS-232/422/485 Connectors: 1 x DB44 Female to 4 x DB9 Male (adapter cable included) Typenumber: CP114EL-I	PCIe x1, x4, x16
	Parallel Port LPT, Bi-Directional, ECP/EPP support Connectors: 1 x DB25F Typenumber: SX-118A	PCIe x1, x4, x16



## 4 x EXPANSION AREA for Optional Modules:

The HTC03 computers supports a multitude of combinations and gives additional features to the unit by taking advantage of the 4 available expansion areas. The table below lists all modules currently available for factory mounting - including combinations and duplicates of each module possible (see next page).

Most of the modules connects internally through USB allowing for easy driver installation and usage, others connects directly to the internal motherboard. For detailed pinout assignments and connector information, please review “Pinout Assignments” and “Housing / Terminal Block Connector Overview” in this manual. Each option have their own dedicated bracket to house the Optional Module securely to the unit’s outer chassis. For technical specifications, see separate datasheets in this manual for each factory mounted module.

Prior to installing module yourselves, the cover should be removed (punch-out plate). The plate is hinged on two small welded points. Bend it sideways and use some force to break it off at one end first, then carefully swing it outwards/inwards as necessary until the opposite hinge break off, and the plate can be fully removed.

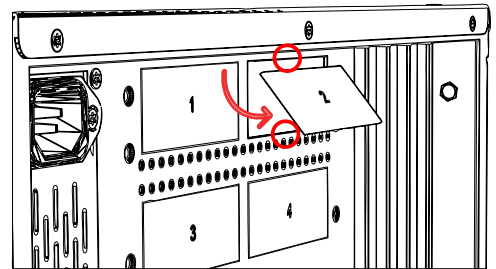

Example illustration showing 4 modules installed:

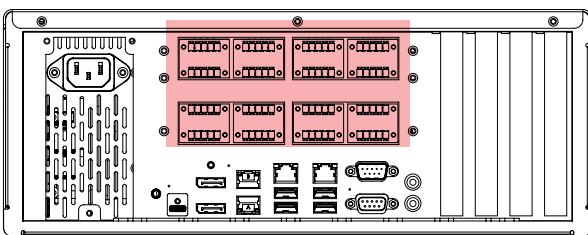

## Module - Options (review dedicated Datasheets in this manual):

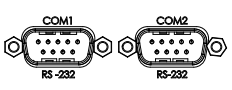
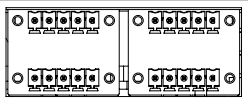
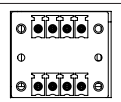
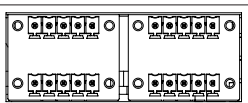
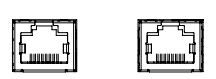
#	Illustration Module	Code ID	Description / Function
A		COM	COM RS-232 Isolated (RS232-2i) Module Connectors: 2 x D-SUB 9P Male Typenumber: PCA100309
B		NMEA COM	RS-422/RS-485 NMEA Isolated / ECDIS Module 4 x 5-pin Terminal Block 3.81 connection Typenumber: PCA200828-1
C		CAN	CAN isolated, 2 channel Module Connector: 4-pin Terminal Block 3.81 connection Typenumber: ZIA0001310-B / ZIA0001310-SLCAN
D		DIO	Digital IO Isolated, 4 Output + 4 Input Module Connectors: 4 x 5-pin Terminal Block 3.81 connection Typenumber: PCA100297-1
E		LAN	LAN 10/100Mbps Module Connectors: 2 x RJ45 Typenumber: PCA100298-1

# User Controls / Physical Connections

## Module Expansion Matrix

Table below indicates how many duplicates of the same module can be installed at the same time. Due to limited number of internal connectors and technical limitations some combinations (with duplicates) are naturally not possible to achieve.

Colored Table Cell refers to the "Upper Row" and "Lower Row" tables above from previous page.

COMx2	NMEA COM	CAN	DIO	LAN
A	B	C	D	E

## Factory Standards

The following illustration indicate mounting locations of the variety of modules available and how they are numbered to keep a persistent configuration. This is seen from user's Point-of-View at rear of the computer unit.

Priority Upper Row		Priority Lower Row
CAN [C]		COMx2 [A]
NMEA COM [B]		NMEA COM [B]
DIO [D]		DIO [D]
LAN [E]		LAN [E]

Priority numbering starts from Upper Row going to right, then Lower Row going to right as illustrated:



# User Controls / Physical Connections

Table below indicates how many combinations of modules is possible to install (each table row totals upto max 4). Further, as per. factory standards, the unique location and shifting of modules are illustrated in the last column, where the number inside the 2x2 table indicate unique id, starting from 1 to max 4 modules.

COM	NMEA COM	CAN	DIO	LAN	Default Factory Mounting Position (upper row / lower row)				
A	B	C	D	E					
1					<table border="1"><tr><td></td><td></td></tr><tr><td>3</td><td></td></tr></table>			3	
3									
2					<table border="1"><tr><td></td><td></td></tr><tr><td>3</td><td>4</td></tr></table>			3	4
3	4								
	1				<table border="1"><tr><td>1</td><td></td></tr><tr><td></td><td></td></tr></table>	1			
1									
	2				<table border="1"><tr><td>1</td><td>2</td></tr><tr><td></td><td></td></tr></table>	1	2		
1	2								
	3				<table border="1"><tr><td>1</td><td>2</td></tr><tr><td>3</td><td></td></tr></table>	1	2	3	
1	2								
3									
	4				<table border="1"><tr><td>1</td><td>2</td></tr><tr><td>3</td><td>4</td></tr></table>	1	2	3	4
1	2								
3	4								
				1	<table border="1"><tr><td>1</td><td></td></tr><tr><td></td><td></td></tr></table>	1			
1									
				2	<table border="1"><tr><td>1</td><td>2</td></tr><tr><td></td><td></td></tr></table>	1	2		
1	2								
			1		<table border="1"><tr><td>1</td><td></td></tr><tr><td></td><td></td></tr></table>	1			
1									
		1			<table border="1"><tr><td>1</td><td></td></tr><tr><td></td><td></td></tr></table>	1			
1									
1	1				<table border="1"><tr><td>1</td><td></td></tr><tr><td>3</td><td></td></tr></table>	1		3	
1									
3									
1				1	<table border="1"><tr><td>1</td><td></td></tr><tr><td>3</td><td></td></tr></table>	1		3	
1									
3									
1			1		<table border="1"><tr><td>1</td><td></td></tr><tr><td>3</td><td></td></tr></table>	1		3	
1									
3									
1		1			<table border="1"><tr><td>1</td><td></td></tr><tr><td>3</td><td></td></tr></table>	1		3	
1									
3									
1	1			1	<table border="1"><tr><td>1</td><td>2</td></tr><tr><td>3</td><td></td></tr></table>	1	2	3	
1	2								
3									
1	1		1		<table border="1"><tr><td>1</td><td>2</td></tr><tr><td>3</td><td></td></tr></table>	1	2	3	
1	2								
3									
1	1	1			<table border="1"><tr><td>1</td><td>2</td></tr><tr><td>3</td><td></td></tr></table>	1	2	3	
1	2								
3									
1	2				<table border="1"><tr><td>1</td><td>2</td></tr><tr><td>3</td><td></td></tr></table>	1	2	3	
1	2								
3									
1	2		1		<table border="1"><tr><td>1</td><td>2</td></tr><tr><td>3</td><td>4</td></tr></table>	1	2	3	4
1	2								
3	4								
1	3	1			<table border="1"><tr><td>1</td><td>2</td></tr><tr><td>3</td><td>4</td></tr></table>	1	2	3	4
1	2								
3	4								
1	1				<table border="1"><tr><td>1</td><td>2</td></tr><tr><td>3</td><td>4</td></tr></table>	1	2	3	4
1	2								
3	4								
1	1	1	1		<table border="1"><tr><td>1</td><td>2</td></tr><tr><td>3</td><td>4</td></tr></table>	1	2	3	4
1	2								
3	4								

# User Controls / Physical Connections

COM	NMEA COM	CAN	DIO	LAN	Default Factory Mounting Position (upper row / lower row)	
A	B	C	D	E		
2					1 3	4
2				1	1 3	4
2			1		1 3	4
2		1			1 3	4
2	1		1		1 3	2 4
2	1	1			1 3	2 4
2	2				1 3	2 4
2		1	1		1 3	2 4
	3		1		1 3	2 4
	3	1			1 3	2 4
	2			1	1 3	2
	2		1		1 3	2
	2	1			1 3	2
	2		1	1	1 3	2 4
	2	1		1	1 3	2 4
	2	1	1		1 3	2 4
	1			1	1	2
	1		1		1	2
	1	1			1	2
	1		1	1	1 3	2
	1	1		1	1 3	2
	1	1	1		1 3	2
			1	1	1	2

## User Controls / Physical Connections

COM	NMEA COM	CAN	DIO	LAN	Default Factory Mounting Position (upper row / lower row)	
A	B	C	D	E		
		1	1	1	1	2
		1	1		1	2

### Factory Preset COM Port Numbering

Hatteland Technology offer a wealth of options resulting in many Operating System numbered COM ports. The table below lists all known ports that are assigned if a specific factory option (or duplicates of them) were factory mounted prior to manufacturing and delivery of units to customer. Internal on-board, PCI based cards and Modules are listed.

The numbering are only applicable for COM Ports, and not other ports, such as network RJ-45.

COM Port #	On-board/factory option	Description
1	RS232/RS422/RS485	Onboard, External connector (DB9)
2	RS232	Onboard, Internal connector (DF11-10S-PA66H)
3	Intel ME	Onboard, Reserved for Intel ME
5-6	PCA100309 Card #1	COM Dual RS-232 Isolated (RS232-2i) Module
7-8	PCA100309 Card #2	COM Dual RS-232 Isolated (RS232-2i) Module
9-10	PCA100309 Card #3	COM Dual RS-232 Isolated (RS232-2i) Module
11-14	MOXA CP-114, Card #1	PCIe Card, 4x COM Ports, Isolated, RS-232/422/485
15-18	MOXA CP-114, Card #2	PCIe Card, 4x COM Ports, Isolated, RS-232/422/485
19	CAN/SLCAN	CAN/SLCAN (ZIA0001310-B/-SLCAN)
20	CAN/SLCAN	CAN/SLCAN (ZIA0001310-B/-SLCAN)
41-44	PCA200828-1, Card #1	4 x RS-422/RS-485 NMEA Isolated/ECDIS Module
45-48	PCA200828-1, Card #2	4 x RS-422/RS-485 NMEA Isolated/ECDIS Module
49-52	PCA200828-1, Card #3	4 x RS-422/RS-485 NMEA Isolated/ECDIS Module
53-56	PCA200828-1, Card #4	4 x RS-422/RS-485 NMEA Isolated/ECDIS Module





# Specifications

# Specifications - HTC03-xx-AC xxxxxxxx

Note: All specifications are subject to change without prior notice! Please visit [www.hattelandtechnology.com](http://www.hattelandtechnology.com) for the latest electronic version.

## TECHNICAL DESCRIPTION

### Computer Specifications:

<ul style="list-style-type: none"> <li>Operating System Support : See table below for options</li> <li>Supported Storage : 2 or 4 x SATA 3.0 (6GB/s) in Removable SSD tray in front (2.5" size). See table below for options</li> <li>Processor : 1 x Intel® Core™ i5-9500E, 6-Core 4.20Ghz, 9MB Cache - See table below for options</li> <li>Memory/RAM : 1 x 8GB (single channel) installed - Max 64GB possible - Dual Channel available - See table below for options</li> <li>Graphics : Intel® UHD 630</li> </ul>	<ul style="list-style-type: none"> <li>Graphics Capabilities : DirectX Support 12.0, Shader Model 6.4, OpenCL 2.1, OpenGL Support 4.5/linux, Vulkan 1.1.97</li> <li>Max Graphics Resolution : Max 3840 x 2160 (4K UHD) @ 60Hz for DP (DisplayPort)</li> <li>System Chipset : Intel® Q370</li> <li>BIOS : UEFI, ACPI support</li> <li>PCIe Slots : 1 x PCIe 3.0 x16 (reserved for additional Graphics Card, See Factory Mounted options below)</li> <li>M.2 Storage (PCIe options) : 1 x PCIe 3.0 x4 (x8 socket) + 1 x PCIe 3.0 x4 + 1 x PCIe 3.0 x1</li> <li>Ethernet #1-2 : 2 x LAN 10/100/1000Mbps, Intel®, Support for Intel® Teaming</li> <li>Ethernet #3-4 : 2 x LAN 10/100/1000Mbps (non intel)</li> <li>USB Ports #1-2 : 2 x USB 3.1 (&lt;3m) ports in front</li> <li>USB Ports #3-6 : 4 x USB 3.1 (&lt;3m) ports in rear</li> <li>USB Ports #7 : 1 x USB-C (DisplayPort - Power Distribution enabled, 60W) in rear</li> <li>Serial Port #1 : 1 x RS-232/RS-422/RS-485 un-isolated Baud Rate: Max 115.2Kbps</li> <li>Audio Onboard : Realtek HD Audio supports 2.0 channel, Mic. in, Line out</li> <li>Audio Amplified : 2W, Stereo/Mono supported</li> <li>Power Manager : ACPI</li> <li>Watchdog Timer : Reset: 1 sec.~255 min. and 1 sec. or 1 min./step</li> <li>H/W Status Monitor : Temperatures, voltages &amp; cooling fan status. Auto throttling control if CPU overheats</li> <li>Other Features : LAN Wakeup, USB Boot, Trusted Platform Module 2.0 (TPM2.0), Intel® Management Engine. True power on after power fail.</li> </ul>	<ul style="list-style-type: none"> <li>External Connector Type:</li> <li>1 x USB-C + 2 x DisplayPort 1.2 (2 x Display clone + 1 extended)</li> <li>2 x RJ45 Teaming</li> <li>2 x RJ45</li> <li>2 x USB Type A</li> <li>4 x USB Type A</li> <li>1 x USB-C</li> <li>1 x DB9M</li> <li>2 x 3.5mm Audio Jack</li> <li>1 x DB9F</li> </ul>
--	---	---

### Power Supply:

- 100-240VAC 50/60Hz
- Power Consumption: Operating: 70W typical - 240W max

### External Connector Type:

Std IEC

### Available Computer Configurations:

Type	Description	Size/Specification
CPU	1 x Intel® Core™ i3-9100E 1 x Intel® Core™ i5-9500E 1 x Intel® Core™ i7-9700E	4-Core 3.10GHz - 3.70GHz, 6MB Cache 6-Core 3.00GHz - 4.20GHz, 9MB Cache 8-Core 2.60GHz - 4.40GHz, 12MB Cache
Memory	DDR4 SO-DIMM 260-pin	- Uses 2 slots, Single or Dual Channel (where applicable), available sizes are: Single Channel: 1x8GB (2400MHz) Dual Channel: 2x8GB (2400MHz), 2x16GB (2400MHz), 2x32GB (2666MHz)
Storage	2.5"/M.2 SSD SATA	- 240Gb (0.9PBW),480Gb (1.2PBW),960Gb (3.4PBW), 1.92Tb (7.1PBW)
OS Option	Microsoft® Windows® Server 2016/2019 64bit, Windows® 10 IoT Enterprise 2019 LTSC (64bit). Linux: Kernel 4.1x or later version	

### Factory Mounted Options:

- CP-114EL-I ELEK KIT: 4xCOM,PCIe x1,1xDB44F to 4xDB9M isolated, RS-232/422/485)
- PNY NVIDIA Quadro P2200: PCIe 3.0 x16, 4 x DP 1.4, 5GB GDDR5
- PNY NVIDIA Quadro P620: PCIe 3.0 x16, 4 x mDP 1.4, 2GB GDDR5
- PNY NVIDIA T600: PCIe 3.0 x16, 4 x mDP 1.4, 4GB GDDR6
- PNY NVIDIA RTX A2000: PCIe 4.0 x16, 4 x mDP 1.4, 6GB GDDR6
- X710T2L / X710T2LBLK: Intel® Network Adapter (10GbE), 2 x RJ45
- I350T4V2 / I350T4V2BLK: Intel® Network Adapter (1GbE), 4 x RJ45
- X710DA2 / X710DA2BLK: Intel® Fiber Network Adapter (10GbE), 2 x SFP+
- X710DA4 / X710DA4BLK: Intel® Fiber Network Adapter (10GbE), 4 x SFP+
- PCA100297-1: Digital IO Isolated, 4 IN + 4 OUT\*
- PCA100298-1: LAN 10/100Mbps, 2 ports (RJ45) module\*
- PCA100309-1: Dual Isolated RS-232, 2xDB9 module\*
- PCA200828-1: COM RS-422/485 isolated NMEA 4 channel, 5-pin T. Block 3.81\*
- SX-118A: Parallel Port LPT, DB25F, Bi-Dir. ECP/EPP, PCIe x1 card
- ZIA0001310-SLCAN: Socket CAN isolated, 2 channel module\*
- ZIA0001310-B: CAN isolated, 2 channel module\*
- VSDxxxxx-x: Additional USB ports. Pending

\* For all Factory Mounted Options, review User Manual for possible HW combinations.

### Available Accessories:

- HT 00225 OPT-A1: 2 x 26" ball bearing sliding rail & mounting kit for 19" Rack
- HT 00224 OPT-A1: 2 x 20" ball bearing sliding rail & mounting kit for 19" Rack
- HT 00223 OPT-A1: 1 x 4U 19" Rack Case Kit(compatible with HT00224/00225)
- HT 00226 OPT-A1: 2 x Mounting Bracket, 4mm SECC+Zinc Plating, RAL9011
- JH C01MF A-A: 1 x USB Cable 1m, Type A-Chassis mount receptacle
- HT 00275 OPT-A1: 1 x PCI Mount Kit EN60945, Low Profile (LP, any len.)
- H733S30Q20-SP000-0: 1 x Replacement Front Air Filter w/4 screws
- HT MBK STD-C1: Mounting Bracket Kit HTC03/HTC04 - L-Shaped
- HD 000TR SX2-A3: 1 x Removable Tray 2.5" w/4xM3x4mm Phillips Countersunk Screws
- HT RET STD-A3: 1 x Cable/Retainer Kit
- 895-0492: USB-C cable, 2m
- USB-C to DP Adapter PENDING
- HT 00262 OPT-A1: 4 x RS-422/RS-485 isolated, USB ext. module
- HT 00263 OPT-A1: 4 x RS-232 COM non-isolated, USB ext. module
- HT 00264 OPT-A1: 1 x CAN isolated, 2 channel, USB ext. module
- HT 00274 OPT-A1: 2 x LAN 10/100Mbps, RJ45, USB ext. module
- HT 00273 OPT-A1: 4 x Digital IN/OUT isolated, USB ext. module
- VSDDPVGA340 / HT DPM2VGA-A1: 1 x DP to VGA adapter
- RC3473 / HT DPM2DVI-DF-A1: 1 x DP to DVI adapter
- DVI-D adapter for P620/T600 Graphics Card: QSP-MINIDP/DVIV2
- DP adapter or P620/T600 Graphics Card: QSP-MINIDP/DPV3
- HDMI adapter or P620/T600 Graphics Card: QSP-MINIDP/HDMIV2
- VGA adapter or P620/T600 Graphics Card: QSP-MINIDP/VGA
- HT 00300 MSOS: OS options -> [www.hattelandtechnology.com/os](http://www.hattelandtechnology.com/os)
- HD xxxxyy SX1-z1: 1 x Removable Tray 2.5" w/Storage Device\*

\*Where xxx=Size of device. yy=GB,TB. z=S (SSD) - Choose Storage Device from table above.

## MECHANICAL DESCRIPTION

### Physical Specifications:

- W:345.00 [13.58"] x H:133.00 [5.24"] x D:392.30 [15.44"] mm [inch]
- Weight: Approx 9.0kg / 19.8lbs
- 2 x Removable SSD tray in front (2.5" size)
- Power/Reset/Power LED Combined Function
- Easy Removable Front Air Filter (spare part accessory available)
- Includes Mounting Brackets (HT 00226 OPT-A1)
- 1 x Internal Cooling fan in front (120x120mm)

Compass Safe Distance: Standard: 150cm - Steering: 130cm

### Environmental Considerations:

- Operating : Temperature -15°C to +55°C - Humidity up to 95%
- Storage : Temperature -20°C to +70°C - Humidity up to 95%

### Lifetime Considerations:

Even though the test conditions for bridge units provide for a maximum operating temperature of 55°C, continuous operation of all electronic components should, if possible, take place at ambient temperatures of only 25°C. This is a necessary prerequisite for long life and low service costs.

## APPROVALS & CERTIFICATES

These products have been tested / type approved by the following classification societies: (\*= Pending)

IEC 60945 4th (EN 60945:2002)  
ABS - American Bureau of Shipping\*

IACS E10  
CCS - China Classification Society

EN61162  
EU RO MR - Mutual Recognition by DNV  
BV - Bureau Veritas\*

ClassNK - Nippon Kaiji Kyokai\*

# Specifications - HTC03-xx-MP xxxxxxxx

Note: All specifications are subject to change without prior notice! Please visit [www.hattelandtechnology.com](http://www.hattelandtechnology.com) for the latest electronic version.

## TECHNICAL DESCRIPTION

### Computer Specifications:

<ul style="list-style-type: none"> <li>Operating System Support : See table below for options</li> <li>Supported Storage : 2 x SATA 3.0 (6GB/s) in Removable SSD tray in front (2.5" size). See table below for options</li> <li>Processor : 1 x Intel® Core™ i5-9500TE, 6-Core 2.20GHz - 3.60GHz (Limited to 35W), 9MB Cache - See table below for options</li> <li>Memory/RAM : 1 x 8GB (single channel) installed - Max 64GB possible - Dual Channel available - See table below for options</li> <li>Graphics : Intel® UHD 630</li> </ul>	<ul style="list-style-type: none"> <li>Graphics Capabilities : DirectX Support 12.0, Shader Model 6.4, OpenCL 2.1, OpenGL Support 4.5/linux, Vulkan 1.1.97</li> <li>Max Graphics Resolution : Max 3840 x 2160 (4K UHD) @ 60Hz for DP (DisplayPort)</li> <li>System Chipset : Intel® Q370</li> <li>BIOS : UEFI, ACPI support</li> <li>PCIe Slots : 1 x PCIe 3.0 x16 (reserved for additional Graphics Card, See Factory Mounted options below)</li> <li>M.2 Storage (PCIe options) : 1 x PCIe 3.0 x4 (x8 socket) + 1 x PCIe 3.0 x4 + 1 x PCIe 3.0 x1</li> <li>Ethernet #1-2 : 2 x LAN 10/100/1000Mbps, Intel®, Support for Intel® Teaming</li> <li>Ethernet #3-4 : 2 x LAN 10/100/1000Mbps (non intel)</li> <li>USB Ports #1-2 : 2 x USB 3.1 (&lt;3m) ports in front</li> <li>USB Ports #3-6 : 4 x USB 3.1 (&lt;3m) ports in rear</li> <li>USB Ports #7 : 1 x USB-C (DisplayPort - Power Distribution enabled, 60W) in rear</li> <li>Serial Port #1 : 1 x RS-232/RS-422/RS-485 un-isolated Baud Rate: Max 115.2Kbps</li> <li>Audio Onboard : Realtek HD Audio supports 2.0 channel, Mic. in, Line out</li> <li>Audio Amplified : 2W, Stereo/Mono supported</li> <li>Power Manager : ACPI</li> <li>Watchdog Timer : Reset: 1 sec.~255 min. and 1 sec. or 1 min./step</li> <li>H/W Status Monitor : Temperatures, voltages &amp; cooling fan status. Auto throttling control if CPU overheats</li> <li>Other Features : LAN Wakeup, USB Boot, Trusted platform module 2.0 (TPM2.0), Intel® Management Engine. True power on after power fail.</li> </ul>	<b>External Connector Type:</b> <ul style="list-style-type: none"> <li>1 x USB-C + 2 x DisplayPort 1.2</li> <li>(2 x Display clone + 1 extended)</li> <li>2 x RJ45 Teaming</li> <li>2 x RJ45</li> <li>2 x USB Type A</li> <li>4 x USB Type A</li> <li>1 x USB-C</li> <li>1 x DB9M</li> <li>2 x 3.5mm Audio Jack</li> <li>1 x DB9F</li> </ul>
---	---	--

### Multi-Power Supply:

• 100-240VAC 50/60Hz+24VDC : Power Consumption - Operating: 70W typical - 156W max

### External Connector Type:

Std IEC + 1 x 2-pin T.Block 5.08

### Available Computer Configurations:

Type	Description	Size/Specification
CPU	1 x Intel® Core™ i3-9100TE 1 x Intel® Core™ i5-9500TE 1 x Intel® Core™ i7-9700TE	4-Core 2.20GHz - 3.20GHz (Max power limited to 35W), 6MB Cache 6-Core 2.20GHz - 3.60GHz (Max power limited to 35W), 9MB Cache 8-Core 1.80GHz - 3.80GHz (Max power limited to 35W), 12MB Cache
Memory	DDR4 SO-DIMM 260-pin	- Uses 2 slots, Single or Dual Channel (where applicable), available sizes are: Single Channel: 1x8GB (2400MHz) Dual Channel: 2x8GB (2400MHz), 2x16GB (2400MHz), 2x32GB (2666MHz)
Storage	2.5"/M.2 SSD SATA	- 240Gb (0.9PBW), 480Gb (1.2PBW), 960Gb (3.4PBW), 1.92Tb (7.1PBW)
OS Option	Microsoft® Windows® Server 2016/2019 64bit, Windows® 10 IoT Enterprise 2019 LTSC (64bit). Linux: Kernel 4.1x or later version	

### Factory Mounted Options:

- CP-114EL-I ELEK KIT: 4xCOM,PCIe x1,1xDB9M isolated, RS-232/422/485)
- PCA100309-1: Dual Isolated RS-232, 2xDB9 module\*
- ZIA0001310-B: CAN isolated, 2 channel module\*
- ZIA0001310-SLCAN: Socket CAN isolated, 2 channel module\*
- SX-118A: Parallel Port LPT, DB25F, Bi-Dir. ECP/EPP, PCIe x1 card
- PCA100297-1: Digital IO Isolated, 4 IN + 4 OUT\*
- PCA100298-1: LAN 10/100Mbps, 2 ports (RJ45) module\*
- PCA200828-1: COM RS-422/485 isolated NMEA 4 channel, 5-pin T. Block 3.81\*
- VSDxxxxxx-x: Additional USB ports. Pending

### Available Accessories:

- HT 00225 OPT-A1: 2 x 26" ball bearing sliding rail & mounting kit for 19" Rack
- HT 00224 OPT-A1: 2 x 20" ball bearing sliding rail & mounting kit for 19" Rack
- HT 00223 OPT-A1: 1 x 4U 19" Rack Case Kit(compatible with HT00224/00225)
- HT 00226 OPT-A1: 2 x Mounting Bracket, 4mm SECC+Zinc Plating, RAL9011
- JH C01MF A-A: 1 x USB Cable 1m, Type A-Chassis mount receptacle
- HT 00275 OPT-A1: 1 x PCI Mount Kit EN60945, Low Profile (LP, any len.)
- H733S30Q20-SP000-0: 1 x Replacement Front Air Filter w/4 screws
- HT MBK STD-C1: Mounting Bracket Kit HTC03/HTC04 - L-Shaped
- HD 000TR SX2-A3: 1 x Removable Tray 2.5" w/4xM3x4mm Phillips Countersunk Screws
- HT RET STD-A3: 1 x Cable/Retainer Kit
- HT 00262 OPT-A1: 4 x RS-422/RS-485 isolated, USB ext. module
- HT 00263 OPT-A1: 4 x RS-232 COM non-isolated, USB ext. module
- HT 00264 OPT-A1: 1 x CAN isolated, 2 channel, USB ext. module
- HT 00274 OPT-A1: 2 x LAN 10/100Mbps, RJ45, USB ext. module
- HT 00273 OPT-A1: 4 x Digital IN/OUT isolated, USB ext. module
- 895-0492: USB-C cable, 2m
- VSDDPVGA340 / HT DPM2VGA-A1: 1 x DP to VGA adapter
- RC3473 / HT DPM2DVI-Df-A1: 1 x DP to DVI adapter
- VSD203404-1 R2: 1x USB-C to DP cable adapter 4K @ 30Hz
- HT 00300 MSOS: OS options -> [www.hattelandtechnology.com/os](http://www.hattelandtechnology.com/os)
- HD xxxxyy SX1-z1: 1 x Removable Tray 2.5" w/Storage Device\*

\*Where xxx=Size of device. yy=GB,TB. z=S (SSD), z=H (HDD) - Choose Storage Device from table above.

## MECHANICAL DESCRIPTION

### Physical Specifications:

- W:345.00 [13.58"] x H:133.00 [5.24"] x D:392.30 [15.440"] mm [inch]
- Weight: Approx 9.0 kg / 19.8lbs
- 2 x Removable SSD tray in front (2.5" size)
- Power/Reset/Power LED Combined Function
- Easy Removable Front Air Filter (spare part accessory available)
- Includes Mounting Brackets (HT 00226 OPT-A1)
- 1 x Internal Cooling fan in front (120x120mm)

Compass Safe Distance: Standard: 150cm - Steering: 130cm

### Environmental Considerations:

- Operating : Temperature -15 to +55°C - Humidity up to 95%
- Storage : Temperature -20 to +0°C - Humidity up to 95%

### Lifetime Considerations:

Even though the test conditions for bridge units provide for a maximum operating temperature of 55°C, continuous operation of all electronic components should, if possible, take place at ambient temperatures of only 25°C. This is a necessary prerequisite for long life and low service costs.

## APPROVALS & CERTIFICATES

These products have been tested / type approved by the following classification societies: (\*= Pending)

IEC 60945 4th (EN 60945:2002)	IACS E10	EN61162	EU RO MR - Mutual Recognition by DNV
ABS - American Bureau of Shipping*	CCS - China Classification Society		BV - Bureau Veritas*
			ClassNK - Nippon Kaiji Kyokai*

This page left intentionally blank



# **Specifications Factory Options**

# Specifications - NMEA / IEC COM Module RS-422 / RS-485

## DATASHEET

This information may not, in whole or in part, be copied, photocopied, reproduced, translated or reduced to any electronic medium or machine-readable form without the prior written consent of Hatteland Technology AS. The products may not be copied or duplicated in any way.

## HATTELAND TECHNOLOGY

an EMBRON Company

Manufacturer: **Hatteland Technology AS**  
 Product: **4 channel RS-422 / RS-485 COM module**  
 Typenumber: **PCA200828-1**

Last Revised: **25 Oct 2021**  
 Revision#: **03**

## 4 channel RS-422 / RS-485, NMEA / IEC COM Module

### Description:

The Hatteland Technology COM modules provide the system with quad independent COM channels. The module is attached to the motherboard via standard USB interface. Application software access the COM channels as standard COM devices, i.e. in the normal case is there no requirements for additional software development. This module will mainly be integrated, electrical and mechanical, in the final products, such as; Series X G1/G2, Series E Panel Computers and selected Stand-alone Computers.

### Internal USB to RS-485 / RS-422 isolated

• Features	- Independent channels (If card is replaced most OS will not change COM port number). - Outputs are short circuits protected. Inputs are protected. - Driver strength are approved. - All channels is fully isolated, channel to channel and channel to chassis. - Classified towards IEC61162-1 and IEC61162-2. - Tested according to EN61162. - NMEA-183 Compliant. - All requirement for usage in ECDIS applications/systems is fulfilled.
• Absolute Max voltage applied to outputs	±15V
• Data Rate / Technical Data Output	- Outputs 230kbps (Theoretically 400kbps). - ±15kV ESD protection on all RS-485 signals. (Human Body Model - HBM) - Isolation rating = 1000V DC 60s, not intended for connection to live power nets.
• Transmitter enable mode	- Standard Mode is automatic. - Standard Mode will accept send by RTS, but will in fact ignore RTS. - Each channel have a override jumper* which can be used to force the transmitter to always be active. See below and next page for details.
• Cable Connector	Terminal Block 5-pin rows (MC 1,5/ 5-STF-3,81) (see illustration below)
• Recommended Cable Thickness	Minimum 22 AWG - Maximum 18 AWG
• Power Consumption	0,6824A @4 active channels, 9600 bit/s, 27Ω load
• Supported Operating Systems (OS)	Microsoft® Windows® 7 Professional/Ultimate (Eng, SP1), Windows® 10 IoT Enterprise 2016 LTSC, Windows® 10 IoT Enterprise 2019 LTSC <b>Linux:</b> Generic support for Kernel 3.0.0.19 or newer

• Drivers  
["https://www.hattelandtechnology.com/hubfs/pdf/misc/doc102080-1\\_usb-com\\_module\\_configuration.pdf"](https://www.hattelandtechnology.com/hubfs/pdf/misc/doc102080-1_usb-com_module_configuration.pdf)  
["https://www.hattelandtechnology.com/hubfs/drivers/ht00262opt-a1\\_drivers.zip"](https://www.hattelandtechnology.com/hubfs/drivers/ht00262opt-a1_drivers.zip)  
["https://www.hatteland-display.com/support\\_hardware\\_drivers\\_peripherals.php"](https://www.hatteland-display.com/support_hardware_drivers_peripherals.php)  
 Linux, please visit: <http://www.ftdichip.com/Drivers/D2XX.htm>

**Note: Listed Operating Systems above are hardware/platform dependent. Please check datasheet for specific unit if OS is supported.**

• Test and certificate	Hatteland Technology standard, (tested / type approved by the following classification societies): * = PENDING <b>IEC 60945 4th</b> (EN 60945:2002)*, <b>IACS E10*</b> , <b>DNV</b> - Det Norske Veritas* / <b>GL</b> - Germanischer Lloyd*, <b>LRS</b> - Lloyd's Register of Shipping*, <b>ABS</b> - American Bureau of Shipping*, <b>BV</b> - Bureau Veritas*, <b>CCS</b> - China Classification Society*, <b>KR</b> - Korean Register of Shipping*, <b>ClassNK</b> - Nippon Kaiji Kyokai*, <b>EU RO MR</b> - Mutual Recognition*
------------------------	--

### Illustration and Pinning:

Note: Product below for illustration only. Location of module and product size/design may differ. Connector/pinning remain the same.

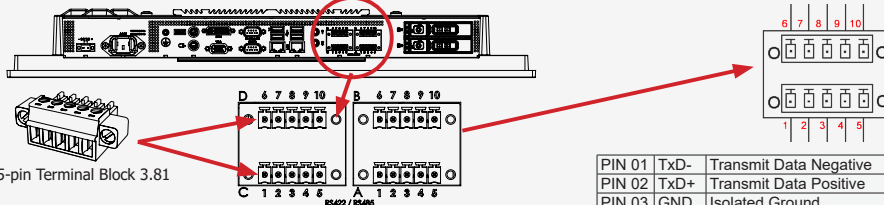

4 Ports (Virtual COM) identified in the Operating System (OS):

COMx (A), COMx (B), COMx (C), COMx (D)\*

\*Configuration dependent, x = next available port number(s) OS.

#### RS-485 Half Duplex (2-wire, supports ECHO) Configuration:

Connect TX and RX pair-wise: TX- to RX-, TX+ to RX+.



\*Note: The jumper for "force of transmitter" is open by factory default. For some custom models this jumper is preset to closed (active), in that case unit has to be opened and jumper set to open to allow Half Duplex mode.

Note: All specifications are subject to change without prior notice!  
Please visit [www.hattelandtechnology.com](http://www.hattelandtechnology.com) for the latest electronic version.

**HATTELAND  
TECHNOLOGY**  
an EMBRON Company



**CAUTION**  
This unit contains electrostatic sensitive devices.  
Observe precautions for handling.



Users who needs to open the unit set jumper settings will VOID THE WARRANTY!  
Before opening, proper ESD measurements must be taken!

1. Operator should ground himself by using a wrist band.
2. The wrist band should be connected to ground via a ground cord.
3. A one megaohm resistor, installed in the wrist connection end of the ground cord, is a safety requirement.
4. Hatteland Technology recommend using a Static-dissipative ESD work mat positioned at the workplace. The 3M™ 8501 Portable Field Service Kit is a good choice for this purpose. Make sure that the mat, operator and product are wired/grounded together.

All assisting persons who might come into contact with the endangered boards must also use the ESD equipment.

## Jumper Configuration:

### Please note:

- By standard factory default, all of the jumpers on all channels are set to open (no jumper), except some customized models as per request.
- It is expected that the user has the required knowledge for working with PCB Cards, electronics and setting jumpers.
- To avoid voiding warranty, please contact us prior to ordering to ensure safe and correct configuration regarding ECHO in factory.
- Incorrect setting of these jumpers can cause strange data losses/corruption which are hard to debug in software.

There are 2 jumpers for each channel (physically they are located as **A,B,D,C** as indicated below). You will have to provide suitable 2mm jumpers (not part of any delivery)  
See illustration showing internal PCB card.

### Forced TX(x):

If this jumper is set it will enable the RS485 transmitter for channel X at all times. It can be useful when the end user need the transmitter to remain on at all times. Note that it is only possible to use one transmitter on the bus when this jumper is set. It will force the bus to a logic high state when there is no traffic. Power consumption is increased if this jumper is set since the termination resistor always see the full output voltage.

### No ECHO(x) - NOTE: Required for some MODBUS Compability.

Jumper mounted: This setting is only to be used during half duplex communication. When this jumper is set it will disable ability to receive data (Echo of transmitted data) while transmitting is active. Some software libraries are not able to use echo and therefore need this jumper set. Typically example is a very common MODBUS library.

Jumper open (no jumper): Recommended setting. All data sent on the bus is read back and the application/driver on the computer can check that we were able to send the data onto the bus.

### Isolation:

This only apply to the module in itself, the internally mounted units are most likely less isolated due to cable/connectors used.

## Jumper Locations (top view)

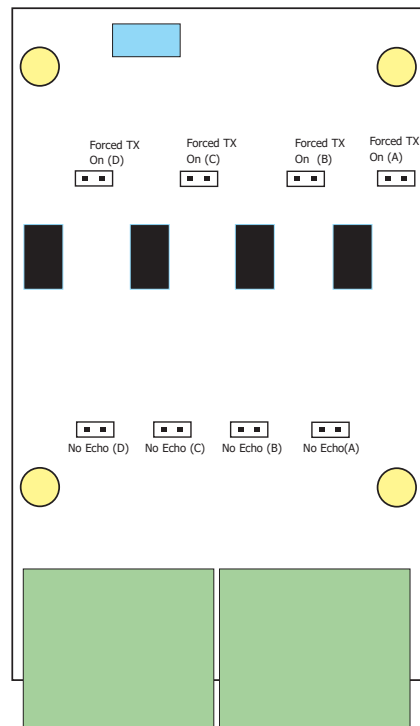

2 x Terminal Block 5-pin rows  
(MC 1,5/ 5-STF-3,81)

# Specifications - NMEA / IEC COM Module RS-422 / RS-485

Note: All specifications are subject to change without prior notice!  
Please visit [www.hattelandtechnology.com](http://www.hattelandtechnology.com) for the latest electronic version.

**HATTELAND TECHNOLOGY**  
an EMBRON Company

## 5-pin Isolated NMEA COM "RS-422/RS-485"

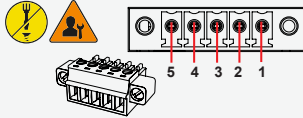

PIN 01	TxD-	Transmit Data Negative
PIN 02	TxD+	Transmit Data Positive
PIN 03	GND	Isolated Ground
PIN 04	RxD-	Receive Data Negative
PIN 05	RxD+	Receive Data Positive

\*Pin 1,2,3,4=RS-422/485 Full Duplex (4-wire)  
\*Pin 1+4, 2+5 = RS-485 Half Duplex (2-wire)  
Connect TxD and RxD pair-wise:  
TxD- to RxD-, TxD+ to RxD+.

Note: Configuration of options for ECHO of transmitted data and to force the transmitter to always active is available in BIOS.

COM Ports are identified in the Operating System (example Microsoft® Windows® 10) as:

COMx (A), COMx (B), COMx (C), COMx (D)\*

\*COM ports are not reserved nor locked by BIOS. x indicate a numeric number from 1-99. COM Port numbering may differ depending on OS used and customized solutions. Review the dedicated User Manual for actual unit, or use the Operating System functions to determine actual port numbering, if problems arise.

Our units are based on an isolated RS-485 interface with enhancements to meet NMEA standard. It is recommended connecting the ground wire since it will help protect the system in event of fast transient voltage and most likely also help improve signal integrity in the system.

For slow changing or DC offset our system will most likely work without the ground wire. If this wire is not connected, our units are more sensitive to fast transient voltage at the connectors. (The "isolated Ground" wire will help absorb this energy).



## RS-422 / RS-485 FULL DUPLEX

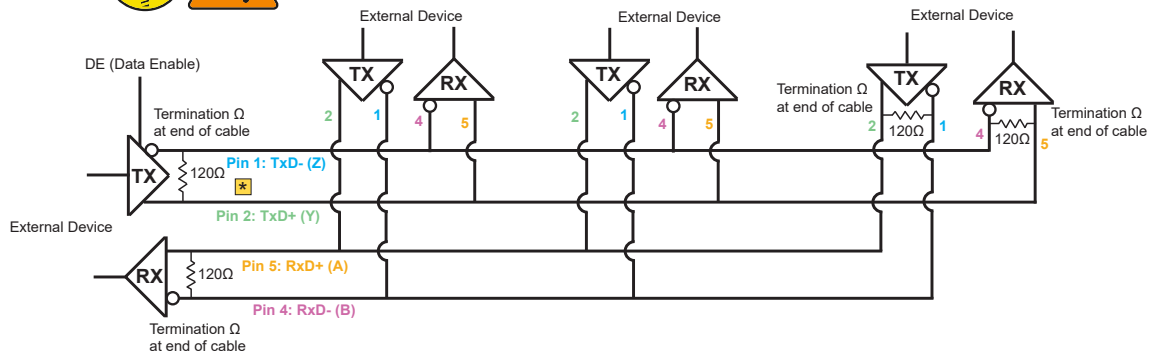

\* Note: 120Ω termination on TX pins are rarely needed, unless cable is long or environment is very noisy.



# Specifications - NMEA / IEC COM Module RS-422 / RS-485

Note: All specifications are subject to change without prior notice!  
Please visit [www.hattelandtechnology.com](http://www.hattelandtechnology.com) for the latest electronic version.

## NMEA Standards:

IEC61162-1 chapter 3.5.5 state that the input shall withstand 15V between ground and input. The reference speed specified is set at 4800 bit/s.

IEC61162-2 chapter 3.1 state that there are 3 wires to be used. (A, B and C). The reference speed for this interface is set as 38400 bit/s.

Please visit <http://www.iec.ch> (International Electrotechnical Commission) for the complete standard description.

## RS-422 / RS-485 FULL DUPLEX

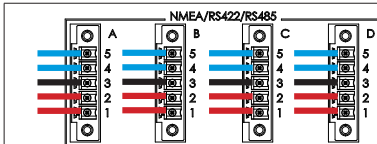

Without Termination:

- **Black** is always connected
- **Blue** is connected when the device acts as a receiver
- **Red** is connected when the device acts as a transmitter

Total 5 wires.

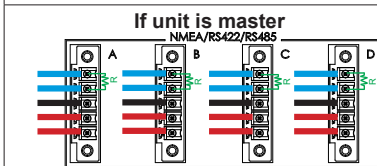

If unit is master

With Termination:

- **Black** is always connected
- **Blue** is connected when the device acts as a receiver
- **Red** is connected when the device acts as a transmitter

Total 5 wires +

**Termination (if unit is master):**

1 x 110/120 Ω resistor between PIN 4 (RxD-) and 5 (RxD+).

**Termination (if unit is slave):**

2 x 110/120 Ω resistor between PIN 4 (RxD-) and 5 (RxD+) and PIN 1 (TxD-) and PIN 2 (TxD+).

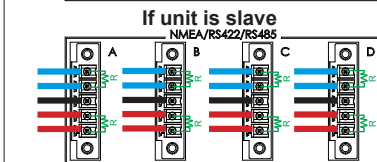

If unit is slave

For each pair there shall be one termination resistor (110/120Ω) at each end of the bus. (A total of 2 resistors on each pair).

PIN 01	TxD-	Transmit Data Negative
PIN 02	TxD+	Transmit Data Positive
PIN 03	GND	Isolated Ground
PIN 04	RxD-	Receive Data Negative
PIN 05	RxD+	Receive Data Positive

## RS-485 HALF DUPLEX

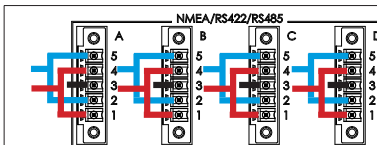

- **Black** Pin 3 is always connected
  - **Blue** is DATA+ (TxD+ connected to RxD+, Pin 5 and 2)
  - **Red** is DATA- (TxD- connected to RxD-, Pin 4 and 1)
- Total 3 wires.

Notes:

- Force TX OFF and (Normally) NO ECHO must be set.
- For each pair there shall be one termination resistor (110/120Ω) at each end of the bus. (A total of 2 resistors on each pair).

PIN 01	TxD-	Transmit Data Negative
PIN 02	TxD+	Transmit Data Positive
PIN 03	GND	Isolated Ground
PIN 04	RxD-	Receive Data Negative
PIN 05	RxD+	Receive Data Positive

# Specifications - CAN Module with CO-Processor

All specifications are subject to change without prior notice!

## DATASHEET

This information may not, in whole or in part, be copied, photocopied, reproduced, translated or reduced to any electronic medium or machine-readable form without the prior written consent of Hatteland Technology AS. The products may not be copied or duplicated in any way.

## HATTELAND TECHNOLOGY

an EMBRON Company

Manufacturer:	<b>Hatteland Technology AS</b>
Product:	<b>CAN Module with CO-Processor</b>
Typenumber:	<b>ZIA0001310-B</b>

Last Revised:	<b>14 Apr 2021</b>
Revision#:	<b>27</b>

## 1 x CAN, 2 channels, CAN Module with CO-Processor

### Description:

CAN Module with CO-Processor (NXP LPC1756) is a USB to dual isolated CAN interface board. This card will mainly be integrated, electrical and mechanical by factory default for Series X G1/G2 Panel Computers and selected Stand-alone Computers. The Hatteland Technology CAN Module is delivered with software download functions and standard API, SAE J2534, which allow the user to add their own functions, such as real time critical functions, and high level CAN protocol. The CAN Module can operate as a standalone unit, which can be configured to operate independent of application software and hardware. This allow the user to use the CAN Module for time and safe critical operations.

Cost effective CAN solution, Withstand marine requirements, General and open architecture that will allow the end customer to modify and handle the source code, General CAN interface support, NMEA2000, J1939, CANOpen.

Note: Due to driver limitations, only 1 instance of this module can be connected to the same Computer/Panel Computer unit. If Computer/Panel Computer already has CAN functionality built-in, connecting this module will always fail.

### Specifications

• Number of CAN interfaces	2 independent channels isolated from each other
• Version	CAN 2.0B
• Isolation	Galvanic isolation 2kV, CAN1 to CAN2 and port to chassis
• Protection	- Continuous short circuit signal to signal - Continuous short circuit to isolated GND - Continuous shorts to ±27V
• ESD rating on CAN bus	ESD rating of ±12kV Human body model
• Min Baud rate	50 kbit/s*
• Max baud rate	500 kbit/s*
<i>*Note: Available Baud Rates are defined in/by the respective protocols. Customized solutions are possible, contact our Sales Department.</i>	
• Address mode	11/29bit
• Terminating	No termination on PCB, user will put them in connector
• PCB Connector	(SCD 3.81/08/90F 3.2SN BK BX) (Do not connect to this, use Terminal Block)
• Cable connector	2 x (BCZ 3.81/04/180F SN BK BX) Terminal Block Connector (see illustration below)
• Cable	Twisted pair, no ground
• Recommended Cable Thickness	Minimum 22 AWG - Maximum 20 AWG
• Supported protocols	SAE J2534 Standard Data Bus Interface
• Power Consumption	Max 204mA @ 5V
• Supported OS	<b>Embedded Enterprise (WEE):</b> Microsoft® Windows® Server 2003/2008/2008R2 (Eng), Microsoft® Windows® 2003/2008/2008R2 (Eng), Microsoft® Windows® 7 Professional/Ultimate (Eng, SP1), Windows® 10 IoT Enterprise 2016 LTSB. <b>Linux:</b> openSUSE® 11.4, Fedora™ 15, Ubuntu® 10.04 LTS, Ubuntu® 12.04 LTS.
<i>Note: Listed Operating Systems above are hardware/platform dependent. Please check datasheet for specific unit if OS is supported.</i>	
• Test and certificate	Hatteland Technology standard (tested / type approved by the following classification societies): <b>IEC 60945 4th</b> (EN 60945:2002), <b>IACS E10, EU RO MR</b> - Mutual Recognition, <b>ClassNK</b> - Nippon Kaiji Kyokai
• Relevant Documentation:	<a href="https://www.hattelandtechnology.com/hubfs/pdf/misc/doc101357-1_hd_can_module_programmer_guide_windows.pdf">https://www.hattelandtechnology.com/hubfs/pdf/misc/doc101357-1_hd_can_module_programmer_guide_windows.pdf</a> <a href="https://www.hattelandtechnology.com/hubfs/pdf/misc/doc101356-1_hd_can_module_programmer_guide_linux.pdf">https://www.hattelandtechnology.com/hubfs/pdf/misc/doc101356-1_hd_can_module_programmer_guide_linux.pdf</a> <a href="https://www.hattelandtechnology.com/hubfs/drivers/can_gw_application_note_package.zip">https://www.hattelandtechnology.com/hubfs/drivers/can_gw_application_note_package.zip</a>

### Illustration and Pinning:

Note: Product below for illustration only. Location of module and product size/design may differ. Connector/pinning remain the same.

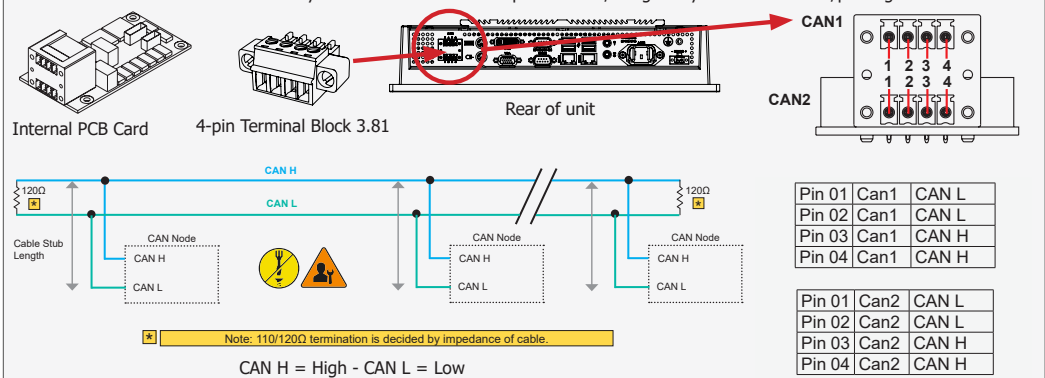

Dimensions might be shown with or without decimals and indicated as mm [inches]. Tolerance on drawings is +/- 1mm. For accurate measurements, check relevant DWG file.

Hatteland Technology AS | www.hattelandtechnology.com | Enterprise no: NO974533146

# Specifications - CAN Module with CO-Processor

All specifications are subject to change without prior notice!

## DATASHEET

This information may not, in whole or in part, be copied, photocopied, reproduced, translated or reduced to any electronic medium or machine-readable form without the prior written consent of Hatteland Technology AS. The products may not be copied or duplicated in any way.

## HATTELAND TECHNOLOGY

an EMBRON Company

Manufacturer: **Hatteland Technology AS**

Product: **CAN Module with CO-Processor**

Typenumber: **ZIA0001310-SLCAN**

Last Revised: **14 Apr 2021**  
Revision#: **09**

## 1 x CAN, 2 channels, CAN Module with CO-Processor

### Description:

CAN Module with CO-Processor (NXP LPC1756) is a USB to dual isolated CAN interface board. This card will mainly be integrated, electrical and mechanical by factory default for Series X Panel Computers and selected Stand-alone Computers. The Hatteland Technology CAN Module support socketCAN driver in both Windows and Linux environment, which allow the user to add their own functions, such as real-time critical functions, and high level CAN protocol. The CAN Module can operate as a standalone unit, which can be configured to operate independent of application software and hardware. This allow the user to use the CAN Module for time and safe critical operations.

Cost effective CAN solution, Withstand marine requirements, General and open architecture that will allow the end customer to modify and handle the source code, General CAN interface support, NMEA2000, J1939, CANOpen.

Note: Due to driver limitations, only 1 instance of this module can be connected to the same Computer/Panel Computer unit. If Computer/Panel Computer already has CAN functionality built-in, connecting this module will always fail.

### Specifications

• Number of CAN interfaces	2 independent channels isolated from each other
• Version	CAN 2.0B
• Isolation	Galvanic isolation 2kV, CAN1 to CAN2 and port to chassis
• Protection	- Continuous short circuit signal to signal - Continuous short circuit to isolated GND - Continuous shorts to ±27V
• ESD rating on CAN bus	ESD rating of ±12kV Human body model
• Min Baud rate	50k bit/s
• Max baud rate	1M bit/s
• Address mode	11/29bit
• Terminating	No termination on PCB, user will put them in connector
• Cable connector	2 x (BCZ 3.81/04/180F SN BK BX) Terminal Block Connector (see illustration below)
• Cable	Twisted pair, no ground
• Recommended Cable Thickness	Minimum 22 AWG - Maximum 20 AWG
• API/Supported Protocols	API: SocketCAN Data Protocol: SLCAN Protocol
• Power Consumption	Max 204mA @ 5V
• Supported OS	<b>Embedded Enterprise (WEE):</b> Windows® 10 IoT Enterprise 2016 LTSB. (Periodic message sending is not supported). <b>Linux:</b> Kernel 2.6.37 or newer with SocketCAN support
• Test and certificate	Hatteland Technology standard (tested / type approved by the following classification societies): <b>IEC 60945 4th</b> (EN 60945:2002), <b>IACS E10</b> , <b>EU RO MR</b> - Mutual Recognition, <b>ClassNK</b> - Nippon Kaiji Kyokai
• Relevant Documentation:	<a href="https://www.hattelandtechnology.com/hubfs/pdf/misc/doc205993-1_usb_slcan_module_user_manual.pdf">https://www.hattelandtechnology.com/hubfs/pdf/misc/doc205993-1_usb_slcan_module_user_manual.pdf</a>
• Suitable Driver Packages:	Windows® Driver: <a href="https://www.hattelandtechnology.com/hubfs/drivers/slcan_setup_hd_gw_svc1.5.0.zip">https://www.hattelandtechnology.com/hubfs/drivers/slcan_setup_hd_gw_svc1.5.0.zip</a> Linux: <a href="https://www.hattelandtechnology.com/hubfs/drivers/customer_pack_hdcan_linux_180222.zip">https://www.hattelandtechnology.com/hubfs/drivers/customer_pack_hdcan_linux_180222.zip</a>

### Illustration and Pinning:

Note: Product below for illustration only. Location of module and product size/design may differ. Connector/pinning remain the same.

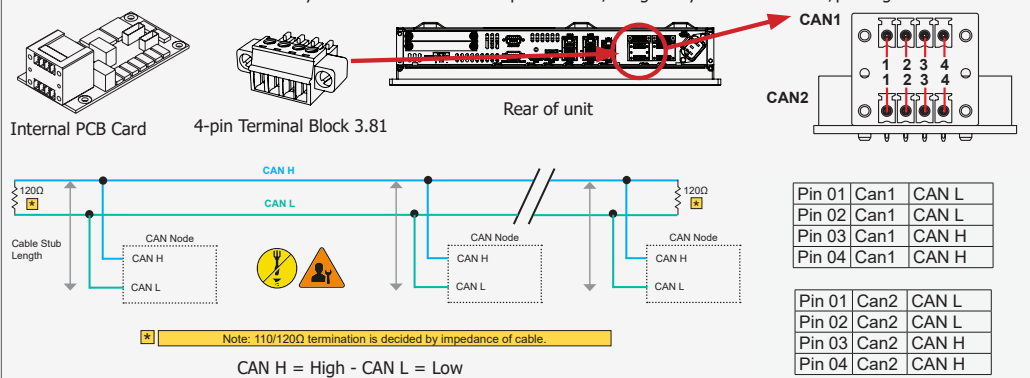

Dimensions might be shown with or without decimals and indicated as mm [inches]. Tolerance on drawings is +/- 1mm. For accurate measurements, check relevant DWG file.

Hatteland Technology AS | [www.hattelandtechnology.com](http://www.hattelandtechnology.com) | Enterprise no: NO974533146

# Specifications - Isolated Digital Input/Output Module

All specifications are subject to change without prior notice!

## DATASHEET

This information may not, in whole or in part, be copied, photocopied, reproduced, translated or reduced to any electronic medium or machine-readable form without the prior written consent of Hatteland Technology AS. The products may not be copied or duplicated in any way.

## HATTELAND TECHNOLOGY

an EMBRON Company

Manufacturer: **Hatteland Technology AS**  
 Product: **Isolated Digital IO module (4 x Output + 4 x Input)**  
 Typenumber: **PCA100297-1**

Last Revised: **25 Oct 2021**  
 Revision#: **18**

### 4 x Isolated Input + 4 x Output, Digital IO Module

#### Description:

The Hatteland Technology DIO module provide the system with 4 isolated digital output and 4 isolated digital input. The module is attached to the motherboard via USB interface. Application software access the DIO channels via D2XX interface provided by the chip manufacturer, i.e. in the normal case is there no requirements for low level software development. This module will mainly be integrated, electrical and mechanical, in the final products, such as; Series X G1/G2 Panel Computers and selected Stand-alone Computers.

Digital Output		Application Circuit
<ul style="list-style-type: none"> <li>Features                             <ul style="list-style-type: none"> <li>- Independent output channels, High side switch.</li> <li>- Outputs are short circuits and overload protected.</li> <li>- Thermal shutdown.</li> <li>- Isolated towards chassis.</li> <li>- Output status/diagnostic feedback available for each output channel.</li> <li>- Outputs is rated for inductive and resistive loads.</li> <li>- Outputs is rated for driving small motors.</li> <li>- Classified towards IEC60945 and IEC60950.</li> </ul> </li> <li>Maximum Ratings                             <ul style="list-style-type: none"> <li>- Voltage: 9-36V continuously.</li> <li>- Load Current: 150mA.</li> <li>- Response time hardware for change of output state &lt;20ms.</li> <li>- Response time hardware for diagnostic feedback &lt;30ms.*</li> <li>- Worst case short circuit current (each channel) &lt; 1.5A.</li> </ul> </li> <li>Typical Application                             <ul style="list-style-type: none"> <li>- Low Power control / relay control.</li> <li>- Medium power buzzer.</li> <li>- Indicator/signal lamps.</li> </ul> </li> </ul>	<ul style="list-style-type: none"> <li>- Voltage: 9-36V continuously.</li> <li>- Load Current: 150mA.</li> <li>- Response time hardware for change of output state &lt;20ms.</li> <li>- Response time hardware for diagnostic feedback &lt;30ms.*</li> <li>- Worst case short circuit current (each channel) &lt; 1.5A.</li> </ul> <p>*Typical response time at system level: 200ms.</p>	
		<p>Above: High side switch concept</p>

Digital Input		Application Circuits
<ul style="list-style-type: none"> <li>Features                             <ul style="list-style-type: none"> <li>- Independent input channels.</li> <li>- Fully isolated towards chassis and channel to channel.</li> <li>- Short circuit and reverse voltage protected.</li> <li>- Classified towards IEC60945 and IEC60950.</li> </ul> </li> <li>Maximum Ratings                             <ul style="list-style-type: none"> <li>- Input voltage 8-36V.</li> <li>- Response time hardware &lt;10ms.</li> <li>- Input current &lt; 20mA.</li> </ul> </li> </ul>		

Dimensions might be shown with or without decimals and indicated as mm [inches]. Tolerance on drawings is +/- 1mm. For accurate measurements, check relevant DWG file.

Hatteland Technology AS | www.hattelandtechnology.com | Enterprise no: NO974533146

1/2

# Specifications - Isolated Digital Input/Output Module

All specifications are subject to change without prior notice!

Note: All specifications are subject to change without prior notice!  
Please visit [www.hattelandtechnology.com](http://www.hattelandtechnology.com) for the latest electronic version.

**HATTELAND  
TECHNOLOGY**  
an EMBRON Company

Additional	
• Cable connector	4 x 5-pin Terminal Block 3.81 connector (MC 1,5/ 5-STF-3,81) - see illustration below
• Recommended Cable Thickness	Minimum 22 AWG - Maximum 18 AWG
• Test and certificate	Hatteland Technology standard, (tested / type approved by the following classification societies): <b>IEC 60945 4th</b> (EN 60945:2002), <b>IACS E10</b> , <b>EU RO MR</b> - Mutual Recognition, <b>ClassNK</b> - Nippon Kaiji Kyokai
• Safety IEC60950	The DIO module is intended to be used in control circuits and does therefore need external fuse to meet safety agency approvals.

## Illustration and Pinning

Note: Product below for illustration only. Location of module and product size/design may differ. Connector/pinning/specifications remain the same.

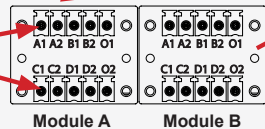
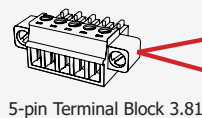
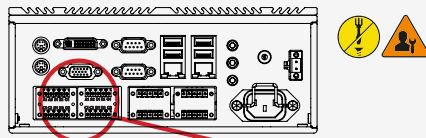

Module A		Module B	
A1	External Power +	A1	IN+[0]
A2	N/C (Not Connected)	A2	IN-[0]
B1	External Power - (GND1)	B1	IN+[1]
B2	N/C (Not Connected)	B2	IN-[1]
O1	HS[0]	O1	N/C
C1	HS[1]	C1	IN+[2]
C2	N/C (Not Connected)	C2	IN-[2]
D1	HS[2]	D1	IN+[3]
D2	N/C (Not Connected)	D2	IN-[3]
O2	HS[3]	O2	N/C

## Supported Operating Systems (OS)

### Embedded Enterprise (WEE):

- Microsoft® Windows® Server 2003/2008/2008R2 (Eng)
- Microsoft® Windows® 2003/2008/2008R2 (Eng)
- Microsoft® Windows® 7 Professional/Ultimate (Eng, SP1)
- Windows® 10 IoT Enterprise 2016 LTSC
- Windows® 10 IoT Enterprise 2019 LTSC

### Linux:

Kernel 3.0.0-19 or above

Note: Listed Operating Systems above are hardware/platform dependent. Please check datasheet for specific unit if OS is supported.

## Currently supported D2XX Drivers

Operating System (OS)	Release Date (yyyy-mm-dd)	Processor Architecture		Comments [Footnote]
		x86 (32-bit)	x64 (64-bit)	
Microsoft® Windows®*	2013-02-20	2.08.28	2.08.28	2.08.28 WHQL Certified [*1] Release Notes [*2]
Linux	2012-06-29	1.1.12	1.1.12	[*3]

\*includes the following versions of the Microsoft® Windows® operating systems:

Windows® XP, Windows® Server 2003, Windows® Vista, Windows® Server 2008, Windows® 7, Windows® Server 2008 R2 and Windows® 8.

For updates, please visit: <http://www.ftdichip.com/Drivers/D2XX.htm>

Footnotes:

[\*1] = [http://www.ftdichip.com/Drivers/CDM/CDM20828\\_Setup.exe](http://www.ftdichip.com/Drivers/CDM/CDM20828_Setup.exe)

[\*2] = <http://www.ftdichip.com/Drivers/CDM/CDM%202%2008%2030%20Release%20Info%20for%208.1.rtf>

[\*3] = <http://www.ftdichip.com/Drivers/D2XX/Linux/ReadMe-linux.txt>

Getting started, documentation and specific Hatteland Technology Library links:

[http://www.ftdichip.com/Support/Documents/ProgramGuides/D2XX\\_Programmer%27s\\_Guide\(FT\\_000071\).pdf](http://www.ftdichip.com/Support/Documents/ProgramGuides/D2XX_Programmer%27s_Guide(FT_000071).pdf)

[https://www.hattelandtechnology.com/hubfs/pdf/misc/doc101781-1\\_programmer\\_guide\\_ht00273opt-a1.pdf](https://www.hattelandtechnology.com/hubfs/pdf/misc/doc101781-1_programmer_guide_ht00273opt-a1.pdf)

[https://www.hattelandtechnology.com/hubfs/drivers/dio\\_pca100297-1\\_ht00273opt-a1\\_package.zip](https://www.hattelandtechnology.com/hubfs/drivers/dio_pca100297-1_ht00273opt-a1_package.zip)

# Specifications - LAN Module

All specifications are subject to change without prior notice!

## DATASHEET

This information may not, in whole or in part, be copied, photocopied, reproduced, translated or reduced to any electronic medium or machine-readable form without the prior written consent of Hatteland Technology AS. The products may not be copied or duplicated in any way.

## HATTELAND TECHNOLOGY

an EMBRON Company

Manufacturer: **Hatteland Technology AS**

Product: **Internal LAN Module RJ-45**

Typenumber: **PCA100298-1**

Last Revised: **10 Mar 2021**

Revision#: **11**

## 2 x LAN RJ-45 - Internal Module

### Description:

The Hatteland Technology USB->Ethernet module provide the system with dual independent Ethernet ports. The module is connected internally to the motherboard via standard USB interfaces. Application software access the ethernet channels as standard ethernet devices, i.e. in the normal case is there no requirements for additional software development. This module can be integrated, electrical and mechanical, for the product such as Series X G1/G2 Panel Computers and selected Stand-alone Computers (Please check datasheet for your unit if PCA100298-1 is listed as part of Factory Options).

### Features:

- USB 2.0 and 1.1 Standard Compliant.
  - Two internal USB ports are required.
  - IEEE 802.3 10Base-T/100 Base-T compatible.
- Note: Wake-on-lan is not supported.

### Internal 2 x USB to 2 x RJ-45

• Connector	1kV Isolated RJ-45, 8-pin connector and pinning. Each port as two LED reporting status of transmit/receive
• Power Consumption	Max 326mA @ 5V
• Test and certificate	Hatteland Technology standard, (tested / type approved by the following classification societies): <b>IEC 60945 4th (EN 60945:2002), IACS E10,</b> <b>EU RO MR</b> - Mutual Recognition, <b>ClassNK</b> - Nippon Kaiji Kyokai
• Supported Operating Systems (OS)	<b>Embedded Enterprise (WEE):</b> Microsoft® Windows® Server 2003/2008/2008R2 (Eng), Microsoft® Windows® 2003/2008/2008R2 (Eng), Microsoft® Windows® 7 Professional/Ultimate (Eng, SP1), Windows® 10 IoT Enterprise 2016 LTSB. <b>Linux:</b> Kernel 3.0.0-64 or above
• Drivers	<a href="http://www.asix.com.tw/products.php?op=pltemdetail&amp;PItemID=105;71;101&amp;PLine=71">http://www.asix.com.tw/products.php?op=pltemdetail&amp;PItemID=105;71;101&amp;PLine=71</a>

Note: Listed Operating Systems above are hardware/platform dependent. Please check datasheet for specific unit if OS is supported.

### Illustration and Pinning:

Note: Product below for illustration only. Location of module and product size/design may differ. Connector/pinning remain the same.

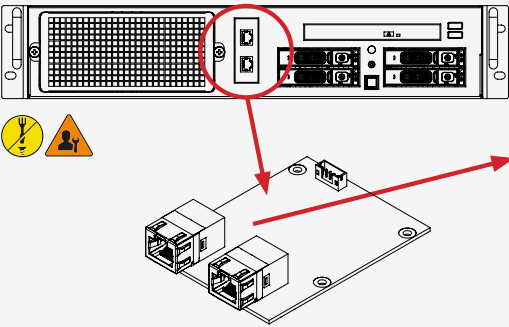

**8-pin RJ-45 10/100Mbps LAN/Ethernet**  
PCA100298-1 / HT 00274 OPT-A1

1	2	3	4	5	6	7	8
Pin 01 - TDP	Pin 02 - TDN	Pin 03 - RDP	Pin 04 - NC	Pin 05 - NC	Pin 06 - RDN	Pin 07 - NC	Pin 08 - NC
Transmit Differential Pair (Positive)	Transmit Differential Pair (Negative)	Receive Differential Pair (Positive)	Not Connected	Not Connected	Receive Differential Pair (Negative)	Not Connected	Not Connected

Dimensions might be shown with or without decimals and indicated as mm [inches]. Tolerance on drawings is +/- 1mm. For accurate measurements, check relevant DWG file.

Hatteland Technology AS | [www.hattelandtechnology.com](http://www.hattelandtechnology.com) | Enterprise no: NO974533146

# Specifications - Isolated COM Module RS-232

All specifications are subject to change without prior notice!

## DATASHEET

This information may not, in whole or in part, be copied, photocopied, reproduced, translated or reduced to any electronic medium or machine-readable form without the prior written consent of Hatteland Technology AS. The products may not be copied or duplicated in any way.

## HATTELAND TECHNOLOGY

an EMBRON Company

Manufacturer:	<b>Hatteland Technology AS</b>
Product:	<b>COM Module RS-232</b>
Typenumber:	<b>PCA100309-1</b>

Last Revised:	<b>10 Mar 2021</b>
Revision#:	<b>06</b>

## 2 channel COM RS-232, DB9M COM Module

### Description:

The Hatteland Technology COM module provide the system with dual independent COM channels. The module is attached to the motherboard via standard USB interface. Application software access the COM channels as standard COM devices, i.e. in the normal case is there no requirements for additional software development. This module will mainly be integrated, electrical and mechanical, in the final product such as Series X G1/G2 Panel Computers and selected stand-alone computers.

### Features:

- 2 independent channels (If a card is replaced most operating system will not change COM port number)
- Outputs are short circuits protected

### Internal USB to 2 channel x RS-232 isolated

• Features	Both channels have support for all RS-232 DB-9 signals
• Connector	Standard RS-232 DB-9 male housing and pinning
• Data Rate	Tested from 300 up to 115200 Baud Rates
• ESD Rating (IEC 1000-4-2 Air) (RS-232 I/Os)	±15 kV
• ESD Rating (IEC 1000-4-2 Contact) (RS-232 I/Os)	±8 kV
• Test and certificate	Hatteland Technology standard, (tested / type approved by the following classification societies): <b>IEC 60945 4th</b> (EN 60945:2002), <b>IACS E10, EU RO MR</b> - Mutual Recognition, <b>ClassNK</b> - Nippon Kaiji Kyokai
• Supported Operating Systems (OS)	<b>Embedded Enterprise (WEE):</b> Microsoft® Windows® Server 2003/2008/2008R2 (Eng), Microsoft® Windows® 2003/2008/2008R2 (Eng), Microsoft® Windows® 7 Professional/Ultimate (Eng, SP1), Windows® 10 IoT Enterprise 2016 LTSC. <b>Linux:</b> Kernel 3.0.0-64 or above
• Drivers/Documentation	<a href="https://www.hattelandtechnology.com/hubfs/drivers/pca100390-1_drivers.zip">https://www.hattelandtechnology.com/hubfs/drivers/pca100390-1_drivers.zip</a>

Note: Listed Operating Systems above are hardware/platform dependent. Please check datasheet for specific unit if OS is supported.

### Illustration and Pinning:

Note: Product below for illustration only. Location of module and product size/design may differ. Connector/pinning remain the same.

PIN 01	DCD	Data Carrier Detect
PIN 02	RxD	Receive Data
PIN 03	TxD	Transmit Data
PIN 04	DTR	Data Terminal Ready
PIN 05	GND	Signal Ground
PIN 06	DSR	Data Set Ready
PIN 07	RTS	Request To Send
PIN 08	CTS	Clear To Send
PIN 09	RI	Ring Indicator

2 Ports available in Operating System as:  
COMx (A)\*, COMx (B)\*

\*Configuration dependent, x = next available port number(s) in operating system.

Dimensions might be shown with or without decimals and indicated as mm [inches]. Tolerance on drawings is +/- 1mm. For accurate measurements, check relevant DWG file.

Hatteland Technology AS | [www.hattelandtechnology.com](http://www.hattelandtechnology.com) | Enterprise no: NO974533146

This page left intentionally blank





# **Specifications Accessories**

# Specifications - External Modules (USB)

All specifications are subject to change without prior notice!

## DATASHEET

This information may not, in whole or in part, be copied, photocopied, reproduced, translated or reduced to any electronic medium or machine-readable form without the prior written consent of Hatteland Technology AS. The products may not be copied or duplicated in any way.

## HATTELAND TECHNOLOGY

an EMBRON Company

Manufacturer:	<b>Hatteland Technology AS</b>
Product:	<b>External Modules - USB Connectivity</b>
Typenumber:	<b>Based on internal modules, see table on page 2</b>

Last Revised:	<b>14 Apr 2021</b>
Revision#:	<b>19</b>

## External Modules - USB Connectivity

### Description:

Hatteland Technology IO module series concept for marine applications adds more functionality to your Maritime Multi Computers and Maritime Stand-Alone computers. They are available as regular factory options for the entire range of Series X Maritime Multi Displays, Maritime Multi Computers and as well as the latest Maritime Stand-Alone computers.

In addition, the module concept has been taken further to a self contained and encased external USB module version. This provides flexibility for new installations and easy upgrade of already installed systems. In fact, any Hatteland Technology product that has a USB2.0 port can take advantage of these External Modules for both legacy, obsolete, current and future products as long as the software and firmware supports the Operating System.

Fully compatible with all Hatteland Technology latest generation products, external cased modules enable system integrators to benefit from the features of these internal options as an external and easy to connect solution. They interface via a standard USB Type A Cable(s) and the chassis comes with its own mounting hinges.

Note for CAN: Due to driver limitations, only 1 instance of this module can be connected to the same Computer/Panel Computer unit. If Computer/Panel Computer already has CAN functionality built-in, connecting this external module will always fail.

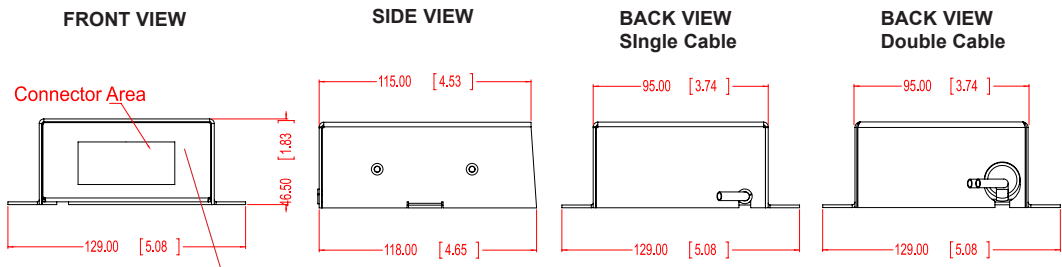
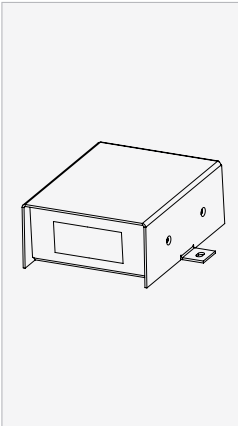

Front plate/silk print indicating type and pinout

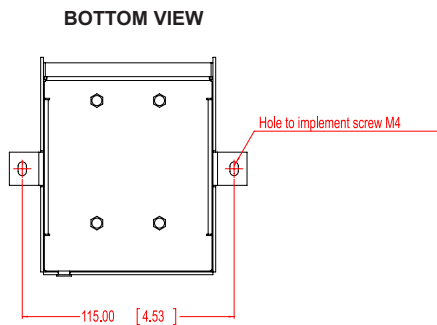

**DIMETRIC VIEW BACK Single Cable**

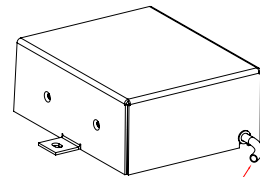

1 x Interior Cable (60cm) Out to USB Type A

**DIMETRIC VIEW BACK Double Cable**

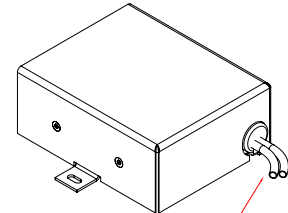

2 x Interior Cables (60cm) Out to USB Type A

Dimensions might be shown with or without decimals and indicated as mm [inches]. Tolerance on drawings is +/- 1mm. For accurate measurements, check relevant DWG file.

Hatteland Technology AS | www.hattelandtechnology.com | Enterprise no: NO974533146

1/2

# Specifications - External Modules (USB)

All specifications are subject to change without prior notice!

**HATTELAND TECHNOLOGY**  
an EMBRON Company

Note: All specifications are subject to change without prior notice!  
Please visit [www.hattelandtechnology.com](http://www.hattelandtechnology.com) for the latest electronic version.

## Ordering Details:

TypeNumber	Description	Internal Specifications (link to separate datasheets)
<b>HT 00262 OPT-A1</b>	<b>NMEA COM</b> 4 x NMEA RS-422/RS-485 isolated Via 5-pin Terminal Block 3.81 Connector Connects through 1 x USB Cable	<b>(Based on PCA200828-1)</b> <a href="http://www.hattelandtechnology.com/hubfs/pdf/ind_ds/ds_pca200828-1_com_module_rs-422_rs-485.pdf">www.hattelandtechnology.com/hubfs/pdf/ind_ds/ds_pca200828-1_com_module_rs-422_rs-485.pdf</a> <a href="http://www.hattelandtechnology.com/hubfs/pdf/misc/doc102080-1_usb-com_module_configuration.pdf">www.hattelandtechnology.com/hubfs/pdf/misc/doc102080-1_usb-com_module_configuration.pdf</a> <a href="http://www.hattelandtechnology.com/hubfs/drivers/ht00262opt-a1_drivers.zip">www.hattelandtechnology.com/hubfs/drivers/ht00262opt-a1_drivers.zip</a> <a href="http://www.hatteland-display.com/support_hardware_drivers_peripherals.php">www.hatteland-display.com/support_hardware_drivers_peripherals.php</a> Linux: <a href="http://www.ftdichip.com/Drivers/D2XX.htm">http://www.ftdichip.com/Drivers/D2XX.htm</a>  <b>(Based on PCA100293-1) - Obsolete</b> <a href="http://www.hattelandtechnology.com/hubfs/pdf/ind_ds/ds_pca100293-1_com_module_rs-422_rs-485.pdf">www.hattelandtechnology.com/hubfs/pdf/ind_ds/ds_pca100293-1_com_module_rs-422_rs-485.pdf</a> <a href="http://www.hattelandtechnology.com/hubfs/pdf/misc/doc102080-1_usb-com_module_configuration.pdf">www.hattelandtechnology.com/hubfs/pdf/misc/doc102080-1_usb-com_module_configuration.pdf</a> <a href="http://www.hattelandtechnology.com/hubfs/drivers/ht00262opt-a1_drivers.zip">www.hattelandtechnology.com/hubfs/drivers/ht00262opt-a1_drivers.zip</a> <a href="http://www.hatteland-display.com/support_hardware_drivers_peripherals.php">www.hatteland-display.com/support_hardware_drivers_peripherals.php</a> Linux: <a href="http://www.ftdichip.com/Drivers/D2XX.htm">http://www.ftdichip.com/Drivers/D2XX.htm</a>
<b>HT 00263 OPT-A1</b>	<b>COM</b> 4 x RS-232 COM Via 4 x DB-9 Male Connector Connects through 1 x USB Cable	<b>(Based on PCA100294-1)</b> <a href="http://www.hattelandtechnology.com/hubfs/pdf/ind_ds/ds_pca100294-1_com_module_rs-232.pdf">www.hattelandtechnology.com/hubfs/pdf/ind_ds/ds_pca100294-1_com_module_rs-232.pdf</a> <a href="http://www.hattelandtechnology.com/hubfs/pdf/misc/doc102080-1_usb-com_module_configuration.pdf">www.hattelandtechnology.com/hubfs/pdf/misc/doc102080-1_usb-com_module_configuration.pdf</a> <a href="http://www.hattelandtechnology.com/hubfs/drivers/ht00263opt-a1_drivers.zip">www.hattelandtechnology.com/hubfs/drivers/ht00263opt-a1_drivers.zip</a>
<b>HT 00264 OPT-A1</b>	<b>CAN</b> 1 x CAN isolated Via 4-pin Terminal Block 3.81 Connector Connects through 1 x USB Cable	<b>(Based on ZIA0001310-B)</b> <a href="http://www.hattelandtechnology.com/hubfs/pdf/ind_ds/ds_zia0001310-b_can_module.pdf">www.hattelandtechnology.com/hubfs/pdf/ind_ds/ds_zia0001310-b_can_module.pdf</a> <a href="http://www.hattelandtechnology.com/hubfs/pdf/misc/doc101357-1_hd_can_module_programmer_guide_windows.pdf">www.hattelandtechnology.com/hubfs/pdf/misc/doc101357-1_hd_can_module_programmer_guide_windows.pdf</a> <a href="http://www.hattelandtechnology.com/hubfs/pdf/misc/doc101356-1_hd_can_module_programmer_guide_linux.pdf">www.hattelandtechnology.com/hubfs/pdf/misc/doc101356-1_hd_can_module_programmer_guide_linux.pdf</a> <a href="http://www.hattelandtechnology.com/hubfs/drivers/can_gw_application_note_package.zip">www.hattelandtechnology.com/hubfs/drivers/can_gw_application_note_package.zip</a>
<b>HT 00264 OPT-A2</b>	<b>SLCAN</b> 1 x CAN isolated Via 4-pin Terminal Block 3.81 Connector Connects through 1 x USB Cable	<b>(Based on ZIA0001310-SLCAN)</b> <a href="http://www.hattelandtechnology.com/hubfs/pdf/ind_ds/ds_zia0001310-scan_can_module.pdf">www.hattelandtechnology.com/hubfs/pdf/ind_ds/ds_zia0001310-scan_can_module.pdf</a> <a href="http://www.hattelandtechnology.com/hubfs/pdf/misc/doc205993-1_usb_slcan_module_user_manual.pdf">www.hattelandtechnology.com/hubfs/pdf/misc/doc205993-1_usb_slcan_module_user_manual.pdf</a> <a href="http://www.hattelandtechnology.com/hubfs/pdf/misc/user_guide_for_hatteland_display_can_interface_driver_(linux).pdf">www.hattelandtechnology.com/hubfs/pdf/misc/user_guide_for_hatteland_display_can_interface_driver_(linux).pdf</a>  Windows® Driver: <a href="http://www.hattelandtechnology.com/hubfs/drivers/slcan_setup_hd_gw_svc1.5.0.zip">www.hattelandtechnology.com/hubfs/drivers/slcan_setup_hd_gw_svc1.5.0.zip</a> Linux: <a href="http://www.hattelandtechnology.com/hubfs/drivers/customer_pack_hdcan_linux_180222.zip">www.hattelandtechnology.com/hubfs/drivers/customer_pack_hdcan_linux_180222.zip</a>
<b>HT 00273 OPT-A1</b>	<b>DIO</b> 4 x Digital Input isolated 4 x Digital Output Via 5-pin Terminal Block 3.81 Connector Connects through 1 x USB Cable	<b>(Based on PCA100297-1)</b> <a href="http://www.hattelandtechnology.com/hubfs/pdf/ind_ds/ds_pca100297-1_4x_digital_module.pdf">www.hattelandtechnology.com/hubfs/pdf/ind_ds/ds_pca100297-1_4x_digital_module.pdf</a> <a href="http://www.hattelandtechnology.com/hubfs/pdf/misc/doc101781-1_programmer_guide_ht00273opt-a1.pdf">www.hattelandtechnology.com/hubfs/pdf/misc/doc101781-1_programmer_guide_ht00273opt-a1.pdf</a> <a href="http://www.hattelandtechnology.com/hubfs/drivers/dio_pca100297-1_ht00273opt-a1_package.zip">www.hattelandtechnology.com/hubfs/drivers/dio_pca100297-1_ht00273opt-a1_package.zip</a>

Most modules interfaces by using Terminal Block type connectors (where applicable), as listed below:

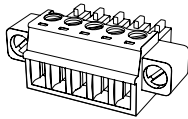

For NMEA COM & DIO Module Connection:  
5-pin  
MC 1,5/ 5-STF-3,81

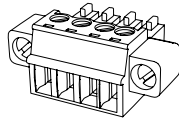

For CAN Module Connection:  
4-pin  
BCZ 3.81/04/180F SN BK BX

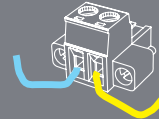

Secure cables with Screw Terminals

Suitable cable housing references:

**For 5-pin:**

<https://www.phoenixcontact.com/online/portal/us?uri=pxc-oc-itemdetail:pid=1834372&library=usen&pcck=P-11-02-01&tab=1>

**For 4-pin**

[http://catalog.weidmueller.com/procat/Product.jsp;jsessionid=B040D5EB6832629E567C884809FDF6C1?productId=\(%5b1005290000%5d\)](http://catalog.weidmueller.com/procat/Product.jsp;jsessionid=B040D5EB6832629E567C884809FDF6C1?productId=(%5b1005290000%5d))

Compass Safe Distance - Standard: 15cm - Steering: 10cm

## APPROVALS & CERTIFICATES

These products have been tested / type approved by the following classification societies:

**IEC 60945 4th (EN 60945:2002) IACS E10**

**EU RO MR - Mutual Recognition (covers DNV, BV, ABS, GL, NK and LRS certificates)\***

\* Pending for HT 00274 OPT-A1 / PCA100298-1

2/2

# Specifications - VSDDPVGGA340 / HT DPM2VGAF-A1

12345

ABCD

**半成品测试要求:**

- 100% Open/Short testing
- Test voltage: 0.1 Sec DC300V
- Insulation resistance: 3 Ohm 10M (min)
- On resistance: 3 Ohm (max)

**成品测试要求:**

- 100%音视频实测机测试

項目	變更內容	日期
3		
2		
1		

制 作	審 核	核 准	客 戶 名 稱 :
余加民	余加民		蔚藍視界科技股份有限公司
			機 種 :
			料 號 : VSDDPVGGA340
			圖 紙 編 號 :

# Specifications - RC3473 / HT DPM2DVI-DF-A1

DESCRIPTION CONTROL			
REV	DESC	DATE	ECN NO

**FILE NO. RC3473 Rev.03-thick copper**

**(1)** DP 蝴蝶夾部份加上一般0.04mm厚度銅箔

**(2)(4)(6)**

**(3)(4)(5)(6)** DVI使用0.08mm厚度銅箔做SHIELD並環焊

有孔位置點焊

**PIN ASSIGNMENT**

P1	P2
SHELL	SHELL
2	GND
3	1
5	GND
4	4
6	GND
8	7
9	GND
19	9
18	16
13	18
14	13
11	14
10	GND
12	10
16	GND
15	12
17	15
20	17

NO	NAME	DESCRIPTION	QTY	UNIT
6	COOPER	COPPER FOIL		
5	HOOD	BLACK PVC 45P MOLDED		
4	INNER	PE-5321 LDPE		
3	CONNECTOR	DVI(24+5) FEMALE WITH NUT	1	PCS
2	CONNECTOR	DP 20PIN MALE NICKLE PLATED SHELL WITH COVER	1	PCS
1	CABLE	UL2027/6 (30#*IP+DAM)*4C+30#*IP+28#*5C+AB BLACK	340	mm

SCALE	DISK	PN:	CUSTOMER PN	DATE	DRAWN BY
1:1		RC3473 Rev. 03-thick copper		20190426	WILLIE

ALL RIGHT ENTERPRISE CO., LTD  
ALL RIGHT 捷豪興業有限公司

A

RoHS COMPLIANT

# Specifications - JH C01MF A-A

## DATASHEET

This information may not, in whole or in part, be copied, photocopied, reproduced, translated or reduced to any electronic medium or machine-readable form without the prior written consent of Hatteland Technology AS. The products may not be copied or duplicated in any way.

## HATTELAND TECHNOLOGY

an EMBRON Company

Manufacturer:	<b>Hatteland Technology AS</b>
Product:	<b>USB Cable 1m</b>
Type:	<b>JH C01MF A-A</b>

### ACCESSORY

Last Revised: **16 Apr 2019**  
Revision#: **08**

## USB Cable

### Description:

USB Cable (Type A plug to Chassis mount Type A receptacle) suitable for installations that feature a secure fastening connection from external equipment with standard Type A ports to all Hatteland Technology computers and panel computers with standard USB Type A ports. RoHS Compliant.

### Specifications

• Waterproof Rate	: IP67. (No Ingress of dust / Protected against harmful effects caused in 1 meter water within 30 minutes)
• Temperature Range	: -20°C to +80°C
• Max Panel Thickness	: 7.0mm (Without Cap Chain)
• Materials	: Housing: Nylon, Black : Conn.1: USB2.0-A, Jack : Conn.2: USB2.0-A, Plug : Cap: Nylon, Black
• Cable	: 1m, UL2725 USB2.0, 28AWG*1P+24AWG*2C+AL+D+B, PVC Jacket, UV Resistant, Black OD=ø5.5mm
• Receptacle Connector	: USB-A Plastic C3 Panel Jack screw with pig tail (GT116300-30)
• Type Approval / Testing	: Hatteland Technology standard, (tested / type approved by the following classification societies): <b>IEC 60945 4th</b> (EN 60945:2002), <b>IACS E10</b> , <b>EU RO MR</b> - Mutual Recognition
• Included with delivery	: 1 x 218-N28 - Cable tie fastener w/glue Panuit 30 : 1 x B2-100 Black Cable tie 2,5x100mm : 1 x GTC Waterproof Mating Cap P/N GT1C533122

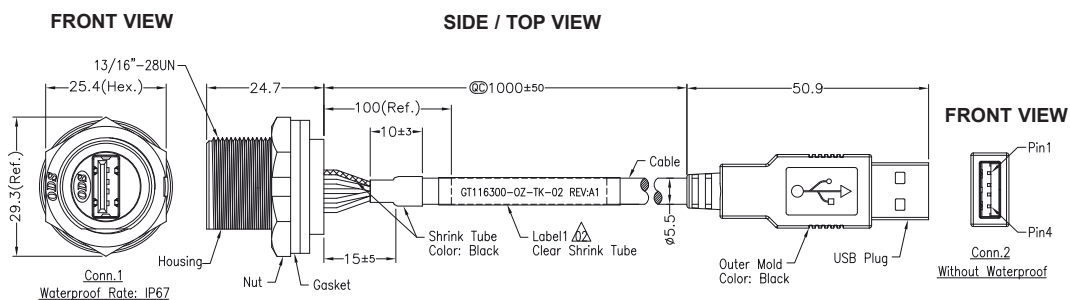

### PIN ASSIGNMENTS FRONT VIEW

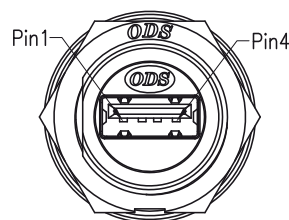

### RECOMMENDED PANEL CUTOUT

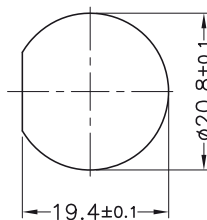

### WIRING DIAGRAM

Shell	Drain	地線	Shell
4	Black	黑	4
3	Green	綠	3
2	White	白	2
1	Red	紅	1
Conn.1	Wire Color		Conn.2
	Pin Out		

Twist

### MATING CAP GT1C533122



Dimensions might be shown with or without decimals and indicated as mm [inches]. Tolerance on drawings is +/- 1mm. For accurate measurements, check relevant DWG file.

Hatteland Technology AS | www.hattelandtechnology.com | Enterprise no: NO974533146



# Technical Drawings

# Technical Drawings - HTC03-xx-AC xxxxxxx

Dimensions might be shown with or without decimals and indicated as mm [inches]. Tolerance on drawings is +/- 1mm. For accurate measurements, check relevant DWG file.

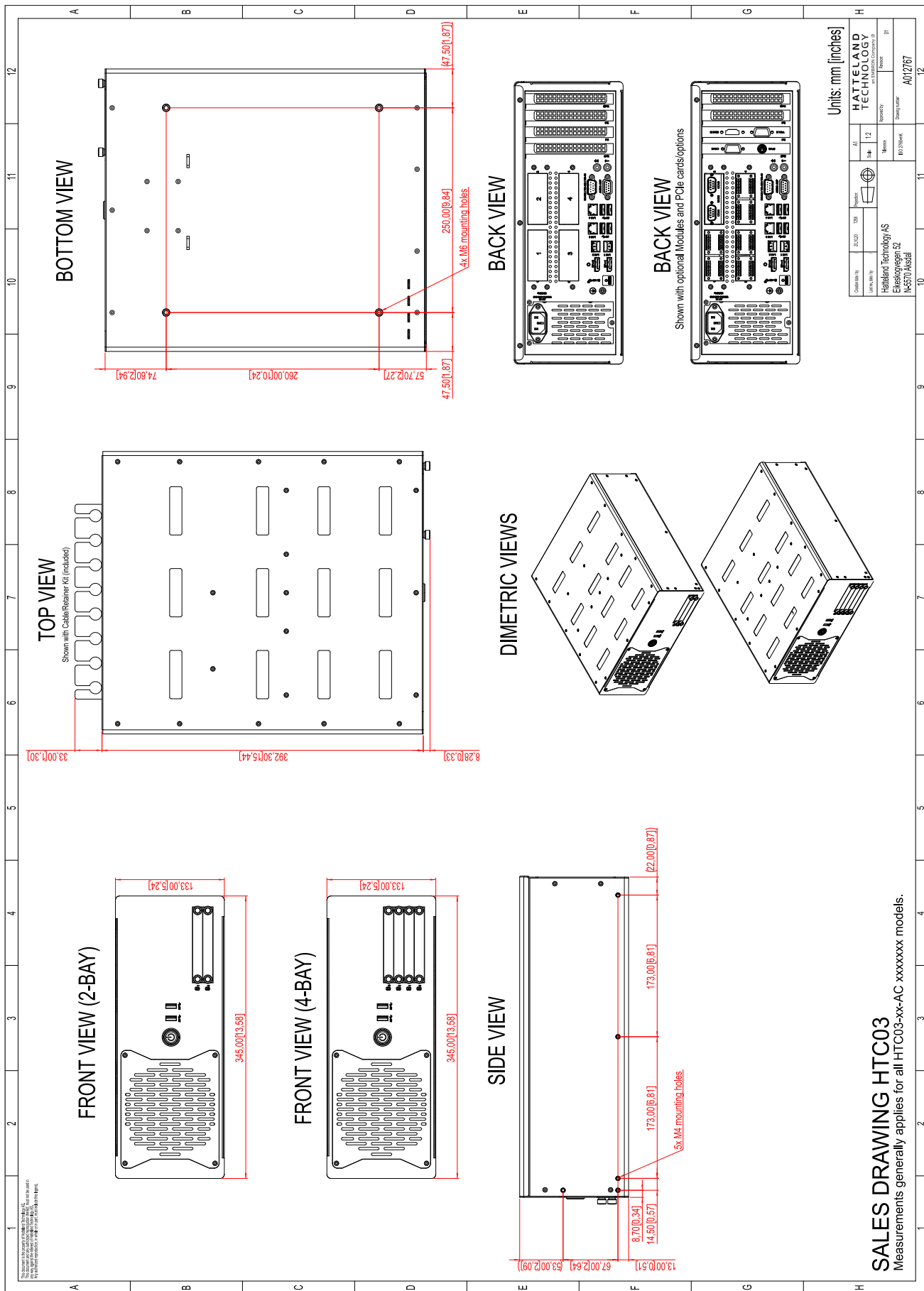

This document is the property of Hatteland Technology AS. This document and any authorized reproduction thereof, must not be used in any way against the interest of Hatteland Technology AS. Any authorized reproduction, in whole or in part, must include this legend. Hatteland Technology AS Proprietary information. Not to be distributed to any third party without written permission.



# Technical Drawings - HTC03-xx-MP xxxxxxx

Dimensions might be shown with or without decimals and indicated as mm [inches]. Tolerance on drawings is +/- 1mm. For accurate measurements, check relevant DWG file.

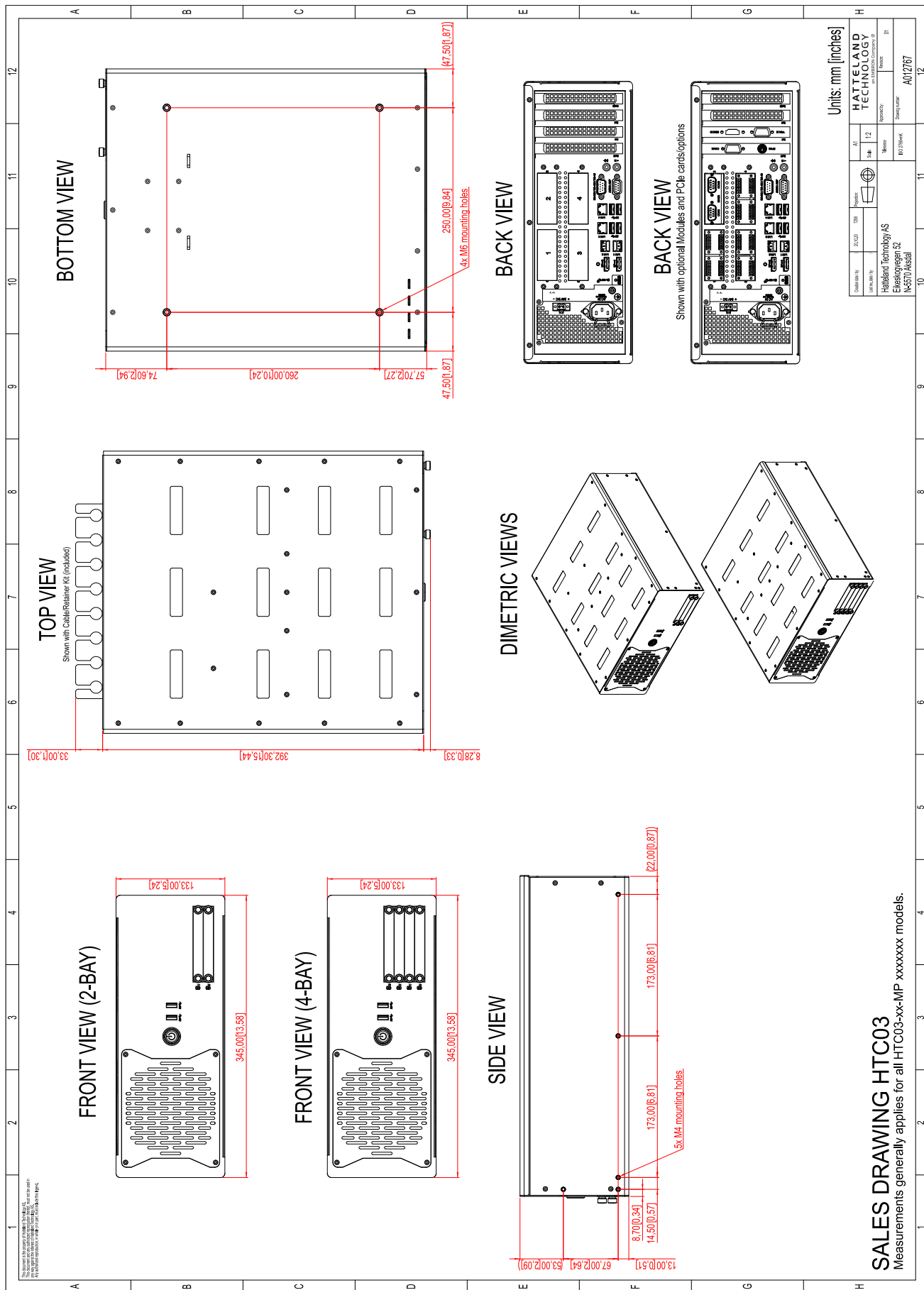

This document is the property of Hatteland Technology AS. This document and any authorized reproduction thereof, must not be used in any way against the interest of Hatteland Technology AS. Any authorized reproduction, in whole or in part, must include this legend. Hatteland Technology AS Proprietary information. Not to be distributed to any third party without written permission.

This page left intentionally blank



# Technical Drawings - Accessories

# Technical Drawings - HT MBK STD-C1

Dimensions might be shown with or without decimals and indicated as mm [inches]. Tolerance on drawings is +/- 1mm. For accurate measurements, check relevant DWG file.

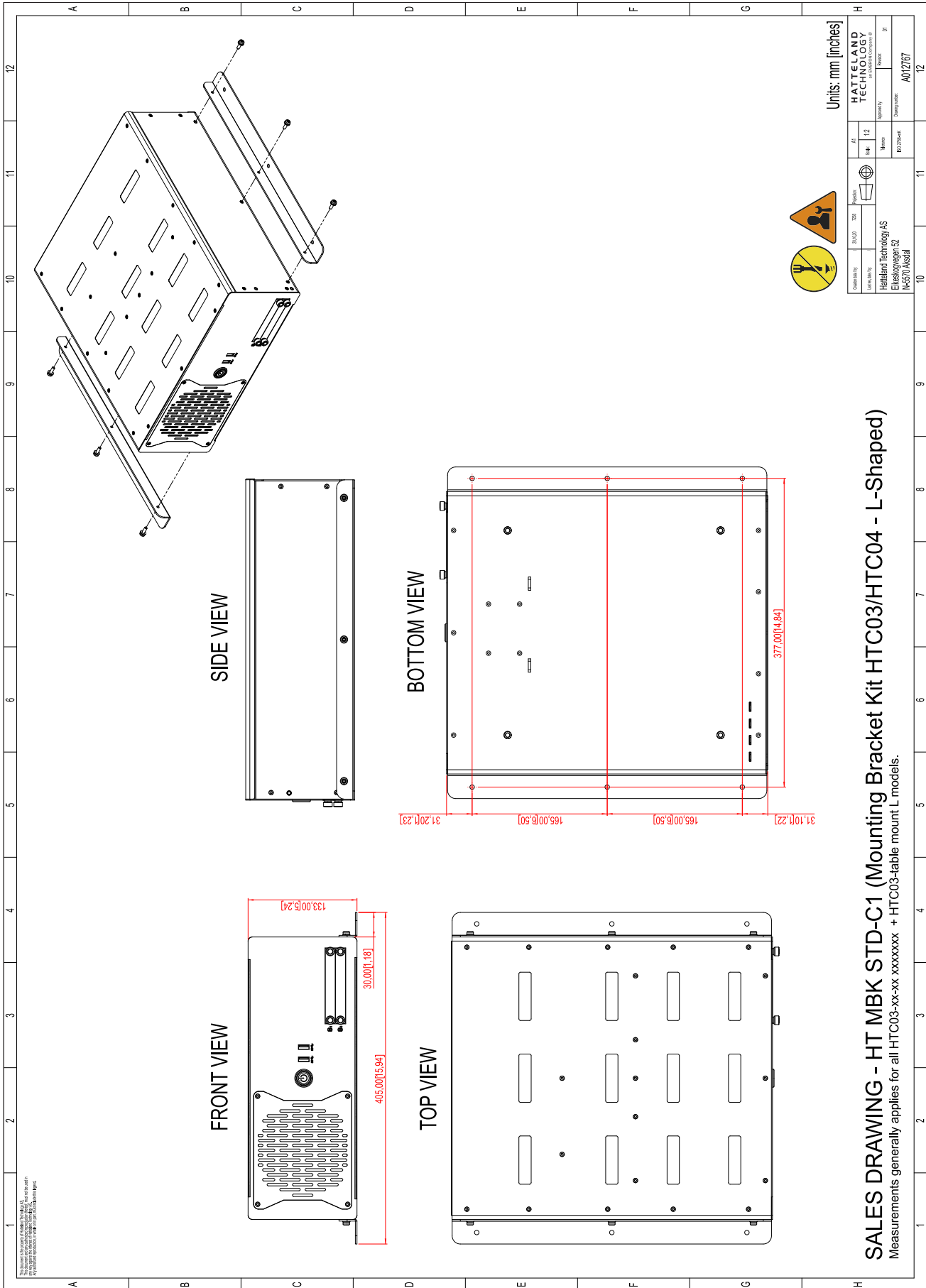

This document is the property of Hatteland Technology AS. This document and any authorized reproduction thereof, must not be used in any way against the interest of Hatteland Technology AS. Any authorized reproduction, in whole or in part, must include this legend. Hatteland Technology AS Proprietary information. Not to be distributed to any third party without written permission.

# Technical Drawings - 19" Rack Kit 4U

Dimensions might be shown with or without decimals and indicated as mm [inches]. Tolerance on drawings is +/- 1mm. For accurate measurements, check relevant DWG file.

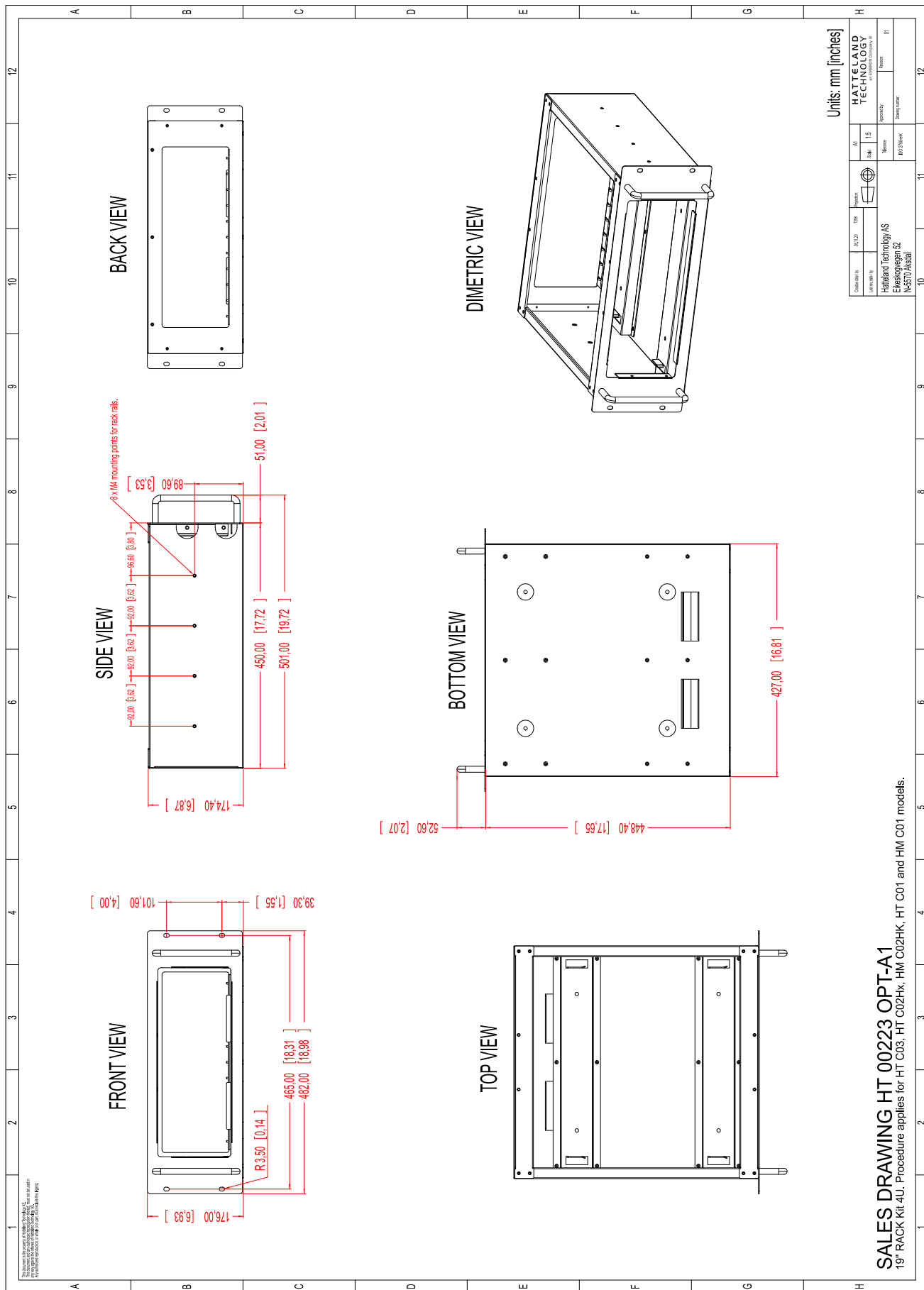

This document is the property of Hatteland Technology AS. This document and any authorized reproduction thereof, must not be used in any way against the interest of Hatteland Technology AS. Any authorized reproduction, in whole or in part, must include this legend. Hatteland Technology AS Proprietary information. Not to be distributed to any third party without written permission.



# Technical Drawings - Mounting Brackets

Dimensions might be shown with or without decimals and indicated as mm [inches]. Tolerance on drawings is +/- 1mm. For accurate measurements, check relevant DWG file.

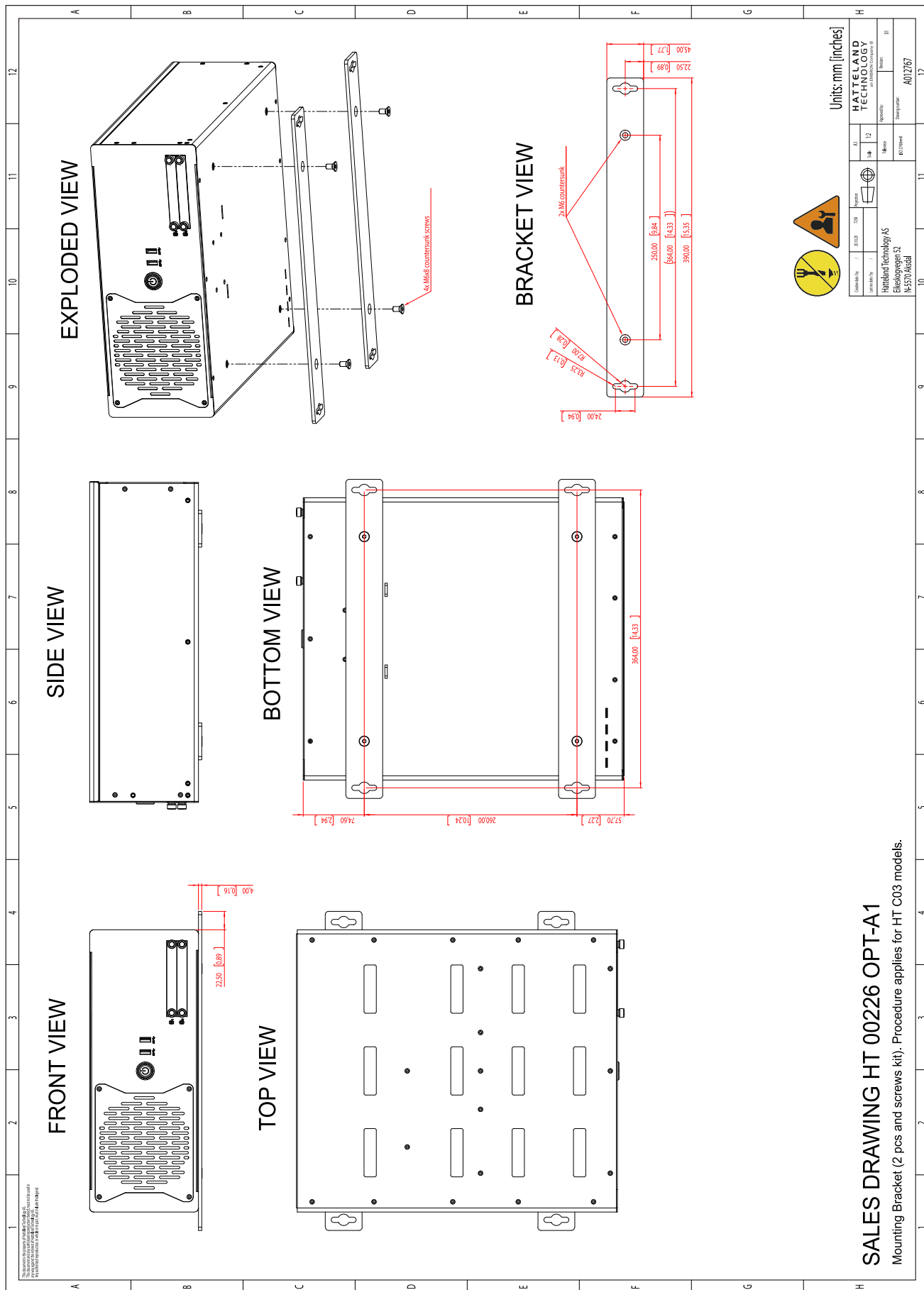

This document is the property of Hatteland Technology AS. This document and any authorized reproduction thereof, must not be used in any way against the interest of Hatteland Technology AS. Any authorized reproduction, in whole or in part, must include this legend. Hatteland Technology AS Proprietary information. Not to be distributed to any third party without written permission.

# Technical Drawings - EN60945 PCI/PCle Support Bracket

Dimensions might be shown with or without decimals and indicated as mm [inches]. Tolerance on drawings is +/- 1mm. For accurate measurements, check relevant DWG file.

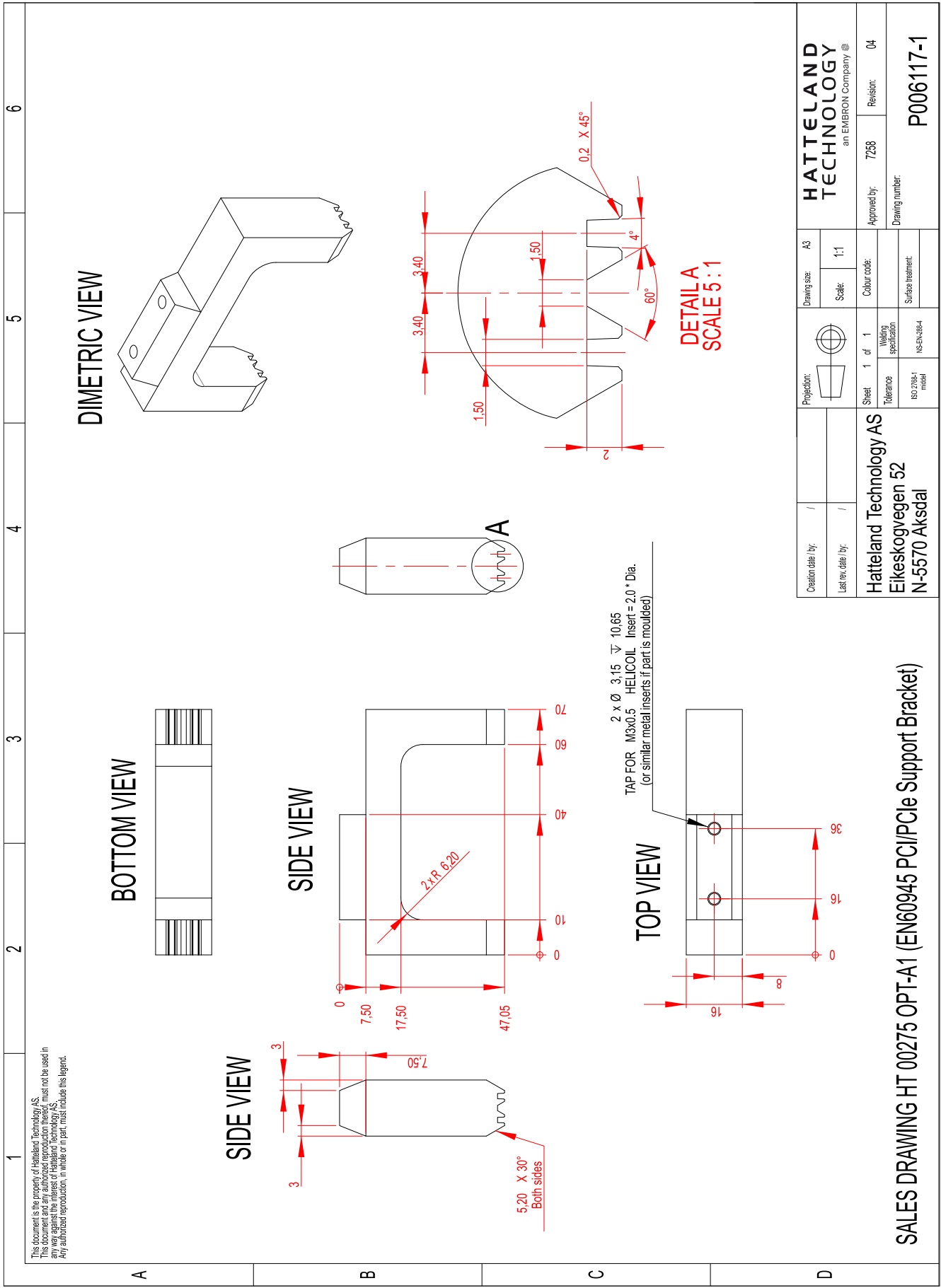

This document is the property of Hatteland Technology AS. This document and any authorized reproduction thereof, must not be used in any way against the interest of Hatteland Technology AS. Any authorized reproduction, in whole or in part, must include this legend.

Creation date by: / /	Projection:	Drawing size: A3	<b>HATTELAND TECHNOLOGY</b> an EMBRON Company	
Last rev. date by: / /	Sheet 1 of 1	Scale: 1:1	Approved by: 7258	Revision: 04
Hatteland Technology AS Eikeskogvegen 52 N-5570 Aksdal		Tolerance: ISO 2768-M	Colour code:	Drawing number: P006117-1
		Welding specification: NS-EN-384	Surface treatment:	

SALES DRAWING HT 00275 OPT-A1 (EN60945 PCI/PCle Support Bracket)

This document is the property of Hatteland Technology AS. This document and any authorized reproduction thereof, must not be used in any way against the interest of Hatteland Technology AS. Any authorized reproduction, in whole or in part, must include this legend. Hatteland Technology AS Proprietary information. Not to be distributed to any third party without written permission.



# Technical Drawings - External Modules (USB)

Dimensions might be shown with or without decimals and indicated as mm [inches]. Tolerance on drawings is +/- 1mm. For accurate measurements, check relevant DWG file.

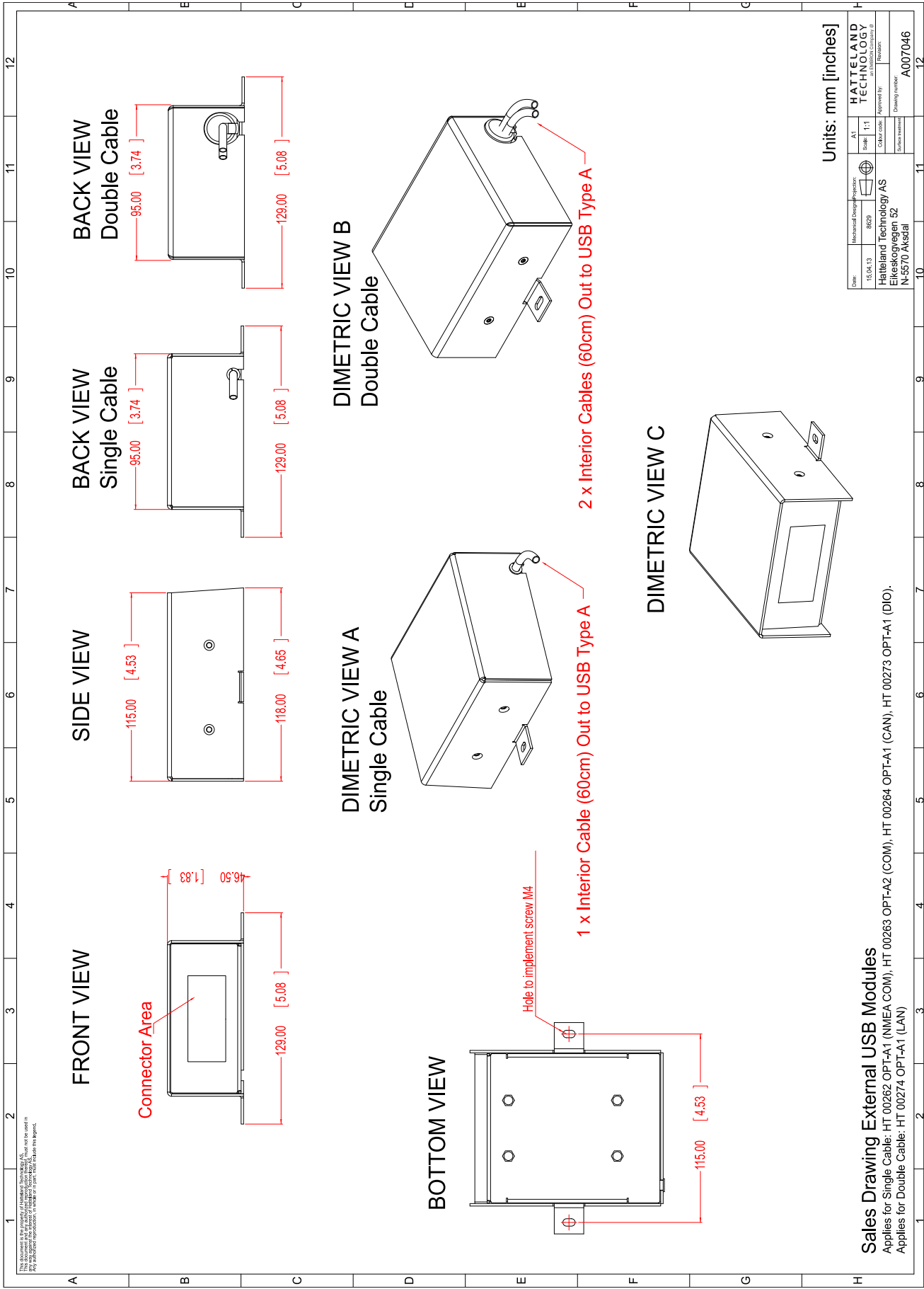

This document is the property of Hatteland Technology AS. This document and any authorized reproduction thereof, must not be used in any way against the interest of Hatteland Technology AS. Any authorized reproduction, in whole or in part, must include this legend. Hatteland Technology AS Proprietary information. Not to be distributed to any third party without written permission.

# Technical Drawings - 20" Slide Rails (for 19" Rack)

Dimensions might be shown with or without decimals and indicated as mm [inches]. Tolerance on drawings is +/- 1mm. For accurate measurements, check relevant DWG file.

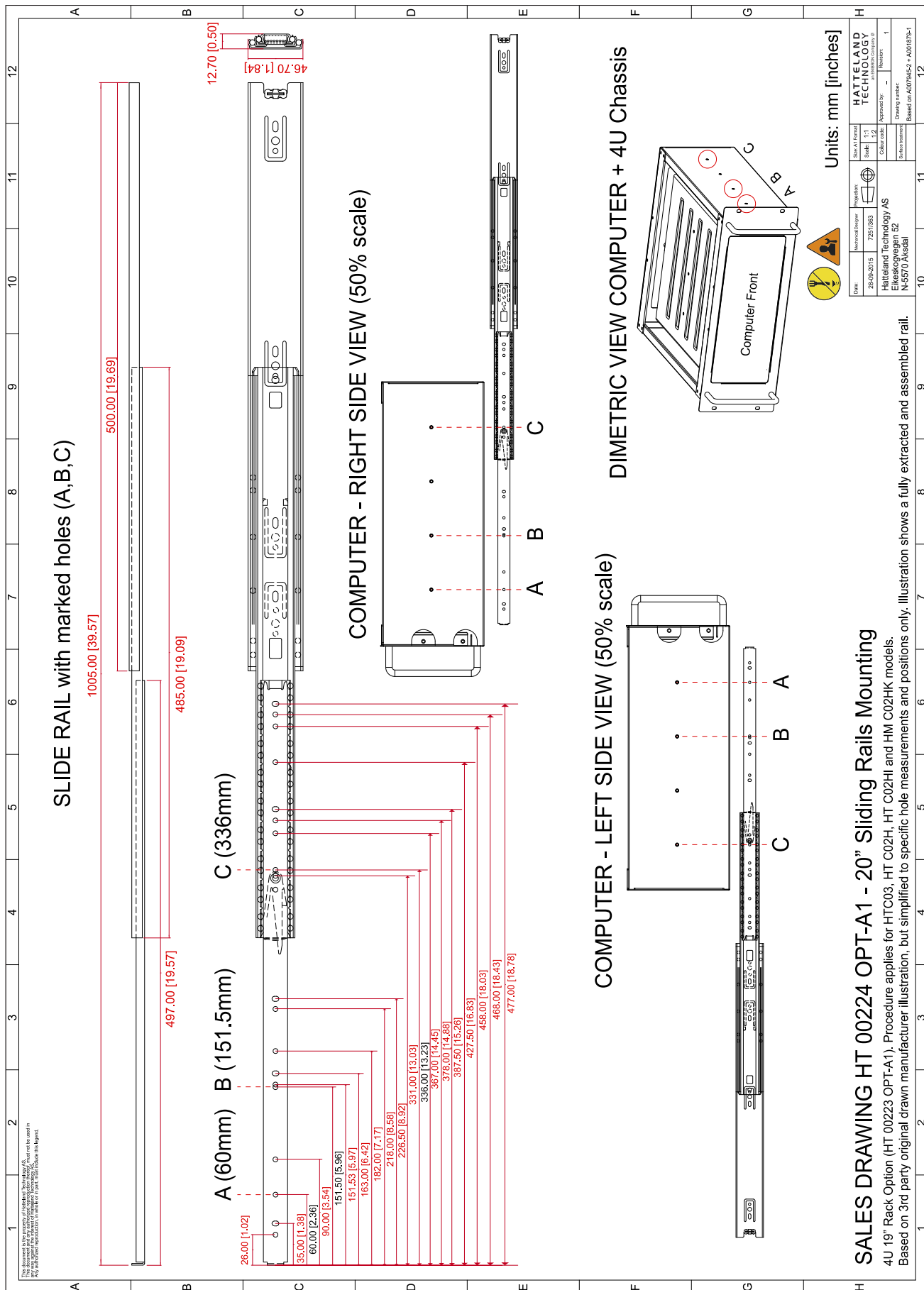

HT 00224 OPT-A1

78

This document is the property of Hatteland Technology AS. This document and any authorized reproduction thereof, must not be used in any way against the interest of Hatteland Technology AS. Any authorized reproduction, in whole or in part, must include this legend. Hatteland Technology AS Proprietary information. Not to be distributed to any third party without written permission.

# Technical Drawings - 26" Slide Rails (for 19" Rack)

Dimensions might be shown with or without decimals and indicated as mm [inches]. Tolerance on drawings is +/- 1mm. For accurate measurements, check relevant DWG file.

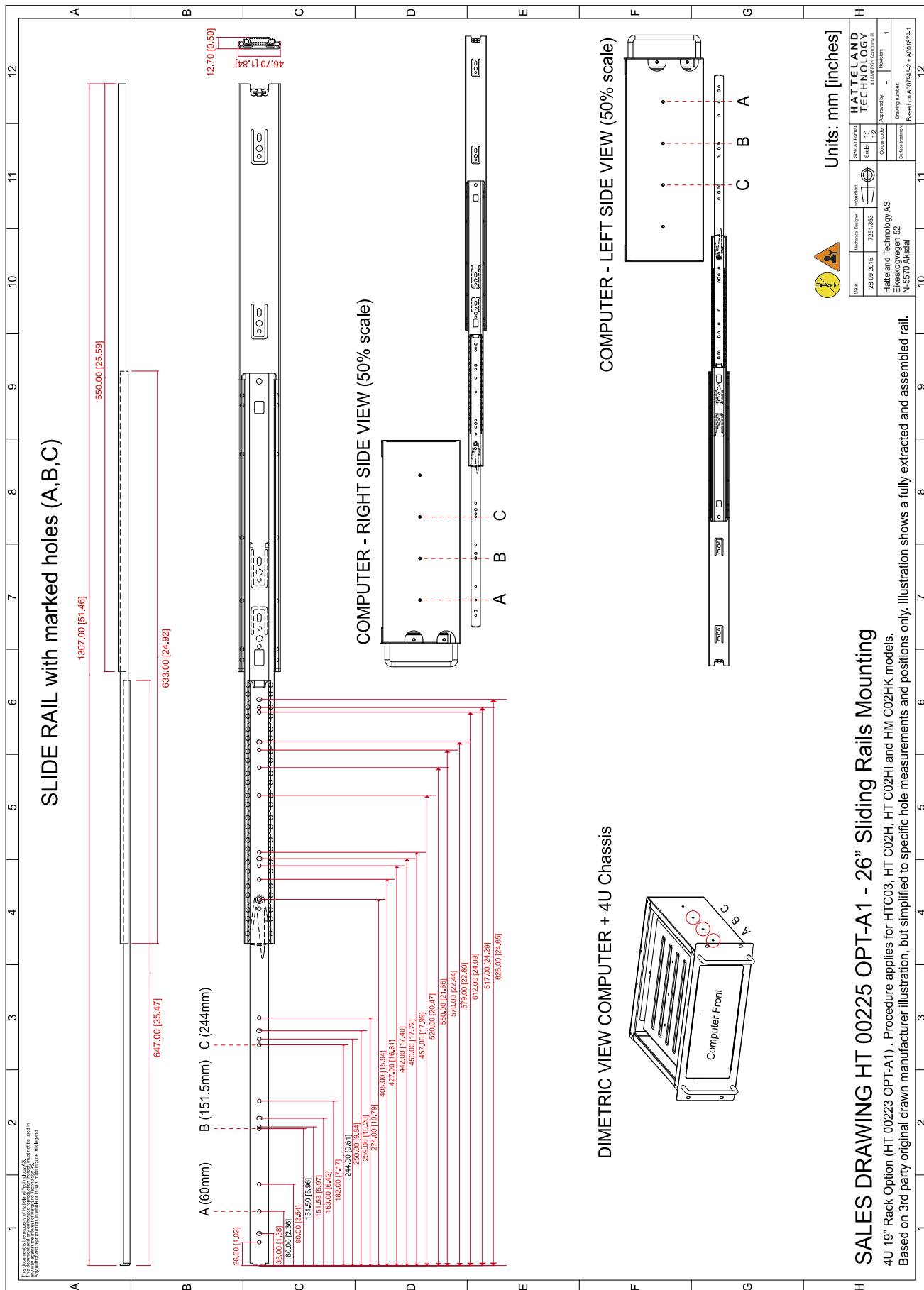

HT 00225 OPT-A1

79

This document is the property of Hatteland Technology AS. This document and any authorized reproduction thereof, must not be used in any way against the interest of Hatteland Technology AS. Any authorized reproduction, in whole or in part, must include this legend. Hatteland Technology AS Proprietary information. Not to be distributed to any third party without written permission.

## SALES DRAWING HT 00225 OPT-A1 - 26" Sliding Rails Mounting

4U 19" Rack Option (HT 00223 OPT-A1). Procedure applies for HTC03, HT C02H, HT C02HI and HM C02HK models.

Based on 3rd party original drawn manufacturer illustration, but simplified to specific hole measurements and positions only. Illustration shows a fully extracted and assembled rail.

This page left intentionally blank



# Appendixes

# SSD Selection Guide

## Solid State Disk (SSD) Devices

Last revised : November 2020

SSD's has many benefits over conventional hard drives where operational performance in marine environment is the reason for Hatteland Technology to recommend SSD's. Historically, the limited write endurance and storage capability vs cost been the main limitations for SSD devices. SSD based at modern technology and with correct dimensioning/usage, will in most cases overcome those short comings.

SSD selected and installed by Hatteland Technology have been through an extensive test program which guarantee that SSD performance complies to defined parameters in the specifications and that the SSD will operate without issues in delivered system configuration, hardware and software combinations, and is suited for its operational (marine) environments .

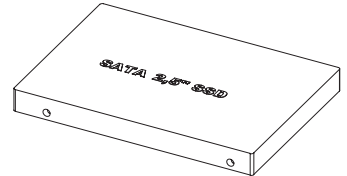

### Selection guide (3d-party SSD):

- Use SSD that is designed for the actual use case, follow recommendations from OS/SW/HW providers.
- Use SSD that is designed and tested vs Enterprise 24/7 operational profile.
- Use SSD where byte written (PBW/TBW) is defined from Enterprise profile; JEDEC218/219 or from full/true random profile.
- Use SSD which can handle unplanned/unscheduled loss of power

SSD devices have limited, but predictable, life time. The life time of the SSD device is directly dependent on the application software.

# SSD Selection Guide

## Calculation / estimation of operational lifetime

Assumed System with Hatteland Technology provided SSD or selected according to guide above.

### 1. Measure/estimate/calculate average disk usage per day.

For measuring, use SMART data.

- o Measure the difference in numbers of write cycles at the start and at end of the test (or the difference in remaining lifetime)
  - o Run the test with relevant disk load and during relevant time period  
Relevant disk load - should correspond to the average disk load during the operational lifetime.  
Relevant time - time it takes to generate relevant disk load with statically significance.
- Many SSD manufacturers provide tool for calculating expected operational lifetime.

### 2. Selection of SSD

Select SSD type/series.

Define minimum expected lifetime [Year]

Define minimum required SSD capacity [GB]

From datasheet,

- check if the endurance is expressed as PBW/TBW or DWPD.
- check warranty [year]

PBW - PetaByte Written = 1000 terabyte written = 1000 000 gigabyte written.

TBW - Total Byte Written normally expressed in terabyte.

DWPD - Disk Write Per Day.

Note relation TBW and DWPD :  $TBW = DPWD * warranty * 365 * SSD\ capacity$ .

Calculate minimum TBW/DPWD.

If TBW in datasheet :  $TBW = Lifetime * 365 * average\ disk\ load\ per\ day$ .

If DPWD in datasheet :  $DPWD = TBW / (warranty * 365 * SSD\ capacity)$ .

Use datasheet,

- Select disk where actual capacity is greater or equal to minimum required capacity and TBW/DPWP in datasheet is greater or equal to calculated minimum TBW/DPWD.

If lifetime is not according to requirements:

Select different SSD, size and/or type, or use mechanism such as over provisioning to extend the operational lifetime.

# SSD Selection Guide

## Calculation of required size of SSD (Multi-Level Cell - MLC) device

The table below details the write endurance of the an enterprise environment. All values are verified by Hatteland Technology during the qualification / selection process. Please review our relevant Product Datasheets for your unit to determine the actual installed device and its TBW values before proceeding with calculations below.

Write Endurance Specifications Previous 2.5" SSD (MLC)		Write Endurance Specifications Current 2.5" SSD (MLC)	
Device Size	Value in TBW (Terabytes)	Device Size	Value in TBW (Terabytes)
80 GB	45	150 GB	412
120 GB	70	240 GB	599
160 GB	100	480 GB	945
240 GB	140	800 GB	1663
300 GB	225	960 GB	1750
600 GB	330	1200 GB	2455
JESD218 standard <sup>1</sup> and based on JESD219 workload.			

Formula for calculating disk size:

$$z = y * x$$

Where **y** = Requested minimum lifetime (with respect to wear out, [year]).

Where **x** = Data rate (GB /per year).

Where **z** = Total amount of data written data to SSD during its whole lifetime.

## Step-by-Step Calculation

Step 1: Measure (preferred) or estimate data rate **y**, [GB /per year].

Step 2: Define minimum expected lifetime for SSD device **x** [year].

Step 3: Calculate total amount of data written to the SSD during its whole lifetime, **z = y \* x**.

Step 4: Use table, **column 2**, the **z** value shall be less or equal to the value in the table to achieve requested lifetime.

Write Endurance Specifications Previous 2.5" SSD (MLC)		Write Endurance Specifications Current 2.5" SSD (MLC)	
Device Size	Value in TBW (Terabytes)	Device Size	Value in TBW (Terabytes)
80 GB	45	150 GB	412
120 GB	70	<b>240 GB</b>	<b>599</b>
160 GB	100	480 GB	945
<b>240 GB</b>	<b>140</b>	800 GB	1663
300 GB	225	960 GB	1750
600 GB	330	1200 GB	2455

Step 5: Select the SSD device, **column 1**, which corresponds to the selected value in **column 2**.

Step 6. Check that the size of the selected SSD is greater than required size of the SSD, if not select the size of the SSD that matches customer requirements.



# SSD Selection Guide

## Measure of number of write cycles (Intel® Solid-State Drive Toolbox software)

Download Software from: <https://downloadcenter.intel.com/download/30162?v=t>

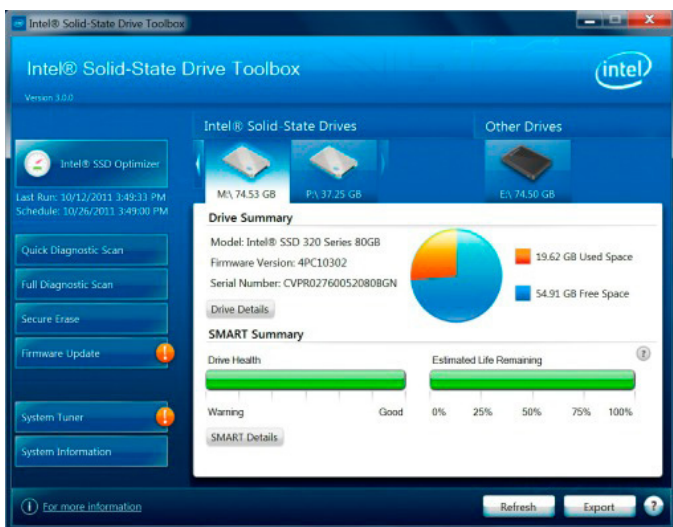

### Preparation

- 1: Install "Intel® Memory and Storage Tool" at target system.
- 2: Install the unit in valid configuration, i.e. the application shall running valid use case, if possible use worst case scenario (with respect to disk activity).
- 3: Before start of measurement, check and store actual SMART data.
  - Start "Intel® Solid-Sate Drive toolbol".
  - Refresh (button at home screen).
  - Export SMART data, store current data at file (button at home screen).

### Measurement

- 1: Check and save time for start test scenario.
- 2: Execute the test scenario long enough to cover all valid use cases which may affect disk activity. (Recommended measurement period is at least 1 week without interruption).
- 3: When the measurement is completed...
  - Check and save time for completion of the test scenario.
  - Start Intel® Solid-Sate Drive toolbox.
  - Refresh (button at home screen).
  - Export SMART data, store current data at file (button at home screen).

### Calculation

- 1: Calculate number of written bytes during the measurement period, use E1 or F1 parameter (stored log file).  
Number of written bytes per second =  $(F1_{\text{completion}} - F1_{\text{start}}) / (\text{Time}_{\text{completion}} - \text{Time}_{\text{start}})$
- 2: Convert to bytes per year.
- 3: Calculate expected life time (see previous time, section "Step-by-Step Calculation").

# BQ370-MH3

## BIOS Step



Ver. 0.1

## BQ370-MH3 BIOS Step

## Contents

<b>1 BIOS Setup Program .....</b>	<b>4</b>
1.1 Legend Box .....	4
1.2 List Box.....	4
1.3 Sub-menu.....	4
<b>2 BIOS Menu Screen.....</b>	<b>5</b>
<b>3 Main Setup.....</b>	<b>6</b>
<b>4 Advanced BIOS Setup.....</b>	<b>7</b>
4.1 CPU configuration .....	8
4.2 PCH-FW Configuration .....	10
4.3 Intel ICC .....	11
4.4 Trusted Computing.....	12
4.5 ACPI Settings.....	13
4.6 NCT6106D Super IO configuration .....	14
4.6.1 Serial Port 1 Configuration.....	15
4.6.2 Serial Port 2 Configuration.....	16
4.6.3 Digital I/O Configuration .....	17
4.7 NCT6106D HW monitor .....	18
4.7.1 Smart FAN .....	19
4.7.1.1 Smart FAN mode Configuration.....	20
4.8 Preheat Function Configuration .....	21
4.9 S5 RTC wake settings.....	22
4.10 Serial Port Console Redirection .....	23
4.11 Intel TXT information.....	24
4.12 USB Configuration .....	25
4.13 CSM (Compatibility Support Module) Configuration .....	26
4.14 NVMe Configuration.....	27
4.15 Network Stack Configuration .....	28
<b>5 Chipset.....</b>	<b>29</b>
5.1 System Agent (SA) Configuration .....	30
5.1.1 Memory configuration.....	30
5.1.2 Graphic Configuration .....	31
5.1.3 PEG Port Configuration .....	33
5.2 PCH-IO configuration.....	34
5.2.1 PCI Express Configuration.....	36
5.2.1.1 PCI Express Root Port 3 (M.2 KeyE) (M2_1) .....	36
5.2.1.2 PCI Express Root Port 4 (PCIe x1 Slot) (PCIEX1_1).....	37
5.2.1.3 PCI Express Root Port 5 (PCIe x8 Slot) (PCIEX8_1).....	38
5.2.1.4 PCI Express Root Port 13 (M.2 KeyM) (M2_2).....	39

## 2 BQ370-MH3 BIOS

5.2.1.5 PCI Express Root Port 21 (PCIe x4 Slot) (PCIEX4_1) .....	40
5.2.2 SATA and RST Configuration .....	41
5.2.3 USB configuration .....	42
5.2.4 HD Audio Configuration.....	43
5.2.5 Serial IO Configuration .....	44
<b>6 Security.....</b>	<b>45</b>
6.1 Secure boot .....	46
6.1.1 Key management .....	47
<b>7 Boot.....</b>	<b>48</b>
<b>8 Save &amp; Exit .....</b>	<b>49</b>

## BQ370-MH3 BIOS Step

### 1 BIOS Setup Program

#### 1.1 Legend Box

The keys in the legend bar allow you to navigate through the various setup menus

Key(s)	Function Description
→←	Select Screen
↑↓	Select Item
Enter	Select
+ -	Change Opt.
F1	General Help
F2	Previous Values
F3	Optimal Defaults
F4	Save and Exit
ESC	Exit

#### 1.2 List Box

This box appears only in the opening screen. The box displays an initial list of configurable items in the menu you selected.

#### 1.3 Sub-menu

Note that a right pointer symbol  appears to the left of certain fields. This pointer indicates that you can display a sub-menu from this field. A sub-menu contains additional options for a field parameter. To display a sub-menu, move the highlight to the field and press <Enter>. The sub-menu appears. Use the legend keys to enter values and move from field to field within a sub-menu as you would within a menu. Use the <Esc> key to return to the main menu.

Take some time to familiarize yourself with the legend keys and their corresponding functions. Practice navigating through the various menus and submenus. If you accidentally make unwanted changes to any of the fields, press <F3> to load the optimal default values. While moving around through the Setup program, note that explanations appear in the Item Specific Help window located to the right of each menu. This window displays the help text for the currently highlighted field.

## 2 BIOS Menu Screen

When you enter the BIOS, the following screen appears. The BIOS menu screen displays the items that allow you to make changes to the system configuration. To access the menu items, press the up/down/right/left arrow key on the keyboard until the desired item is highlighted, then press [Enter] to open the specific menu.



# BIOS - Overview and functions

## BQ370-MH3 BIOS Step

### 3 Main Setup

This menu gives you an overview of the general system specifications. The BIOS automatically detects the items in this menu. Use this menu for basic system configurations, such as time, date etc.



#### BIOS Information

Displays the auto-detected BIOS information.

- **System Date**

The date format is <Date>,<Month>,<Day>,<Year>.

- **System Time**

The time format is <Hour>,<Minute>,<Second>.

## 4 Advanced BIOS Setup

Select the Advanced tab from the setup screen to enter the Advanced BIOS Setup screen. You can select any of the items in the left frame of the screen, such as Chipset configuration, to go to the sub menu for that item. You can display an Advanced BIOS Setup option by highlighting it using the <Arrow> keys. All Advanced BIOS Setup options are described in this section. The Advanced BIOS Setup screen is shown below. The sub menus are described on the following pages.

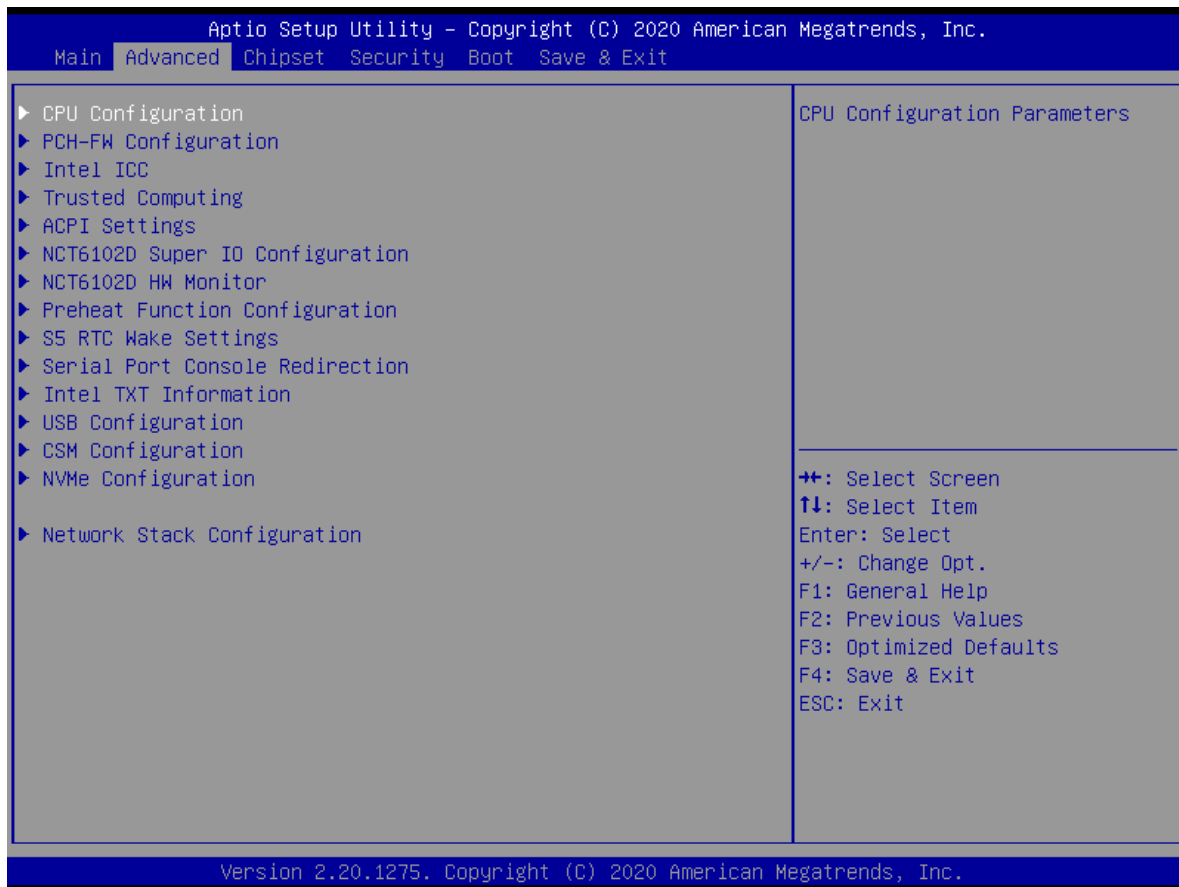

Take caution when changing the settings of the Advanced menu items. Incorrect field values can cause the system to malfunction.



# BIOS - Overview and functions

## BQ370-MH3 BIOS Step

### 4.1 CPU configuration

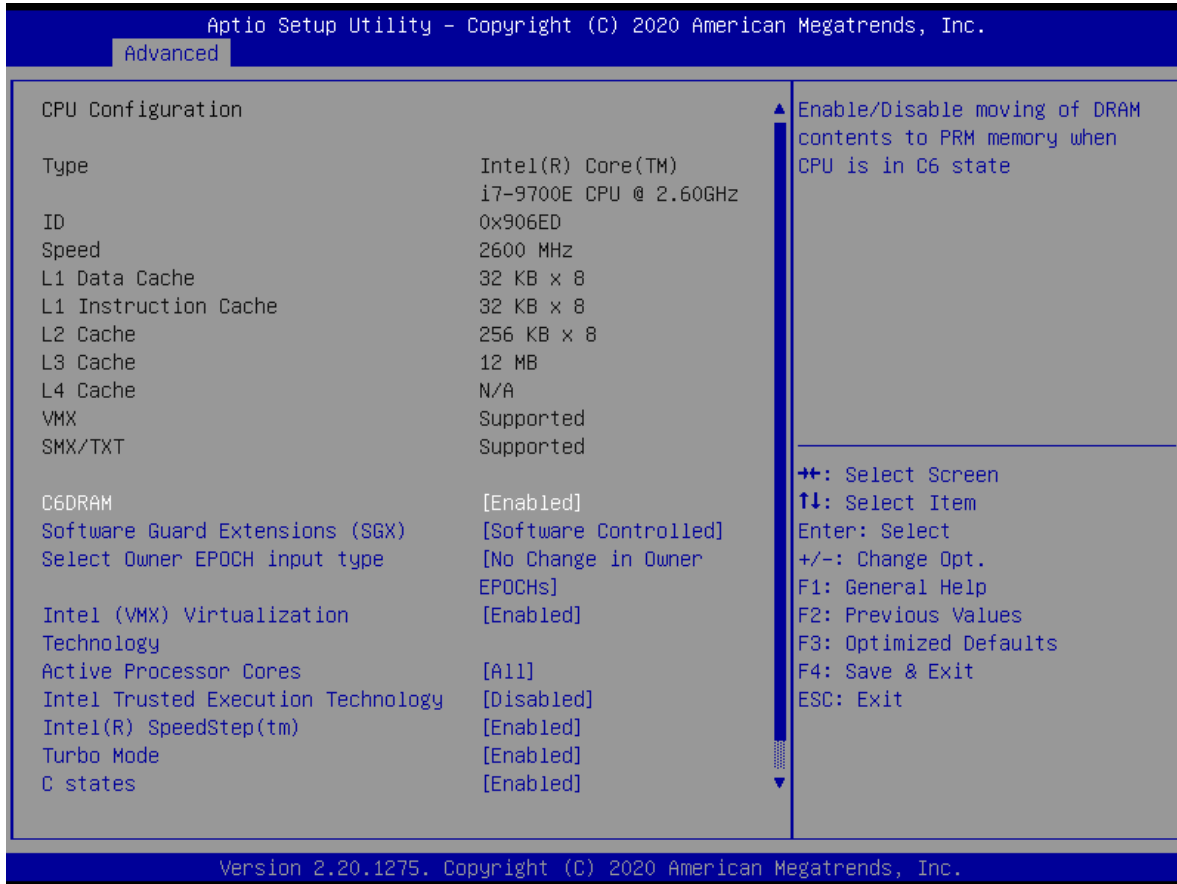

These options may differ to each CPU. It depends on the feature and items of each CPU models. This screenshot is for reference only.

- **C6DRAM [Enabled]**  
Enabled or Disabled moving DRAM content to PRM memory when CPU is in C6 state.  
Configuration options: [Disabled][Enabled]  
This depends on CPU sku.
- **Software Guard Extensions(SGX) [software controlled]**  
Enable or disables Guard Extensions  
Configuration options:[Disabled][Enabled][Software Controlled]
- **Select owner EPOCH input type [No change in owner EPOCHs]**  
After user enters EPOCH values manually, the values will not be visible for security reasons  
Configuration options:[No Change in Owner EPOCHs][Change to New Random Owner EPOCHs][Manual User Defined Owner EPOCHs]
- **Intel Virtualization Technology [Enabled]**  
When enabled, a VMM can utilize the additional hardware capabilities provided by Vandrpool Technology

- Configuration options: [Disabled][Enabled]
- **Active Processor Cores [All]**  
Number of cores to enable in each processor package  
Configuration options: [All] [1][2][3][4][5][6][7]  
This depends on CPU sku.
  - **Intel Trusted Execution Technology [Disabled]**  
Enabled or Disabled Intel Trusted Execution Technology.  
Configuration options: [Disabled][Enabled]
  - **Intel® SpeedStep™ [Enabled]**  
Allow more than two frequency ranges to be supported.  
Configuration options: [Disabled][Enabled]
  - **Turbo mode [Enabled]**  
Enable or disable Turbo mode  
Configuration options: [Enabled][Disabled]
  - **C status [Enabled]**  
Enable or disable CPU Power Management. Allows CPU to go to C states when it's not 100% utilized.  
Configuration options: [Enabled][Disabled]
    - **Enhanced C-states: [Enabled]**  
Enable/Disable C1E. When enabled, CPU will switch to minimum speed when all cores enter C-State.  
Configuration options: [Disabled][Enabled]
  - **Package C State Limit [Auto]**  
It's Maximum Package C State Limit Setting. Cpu Default: Leaves to Factory default value. Auto: Initializes to deepest available Package C State Limit.  
Configuration options: [C0/C1][C2][C3][C6][C7][C7S][C8][C9][C10][Cpu Default][Auto]

# BIOS - Overview and functions

## BQ370-MH3 BIOS Step

### 4.2 PCH-FW Configuration

It shows ME version and ME status.

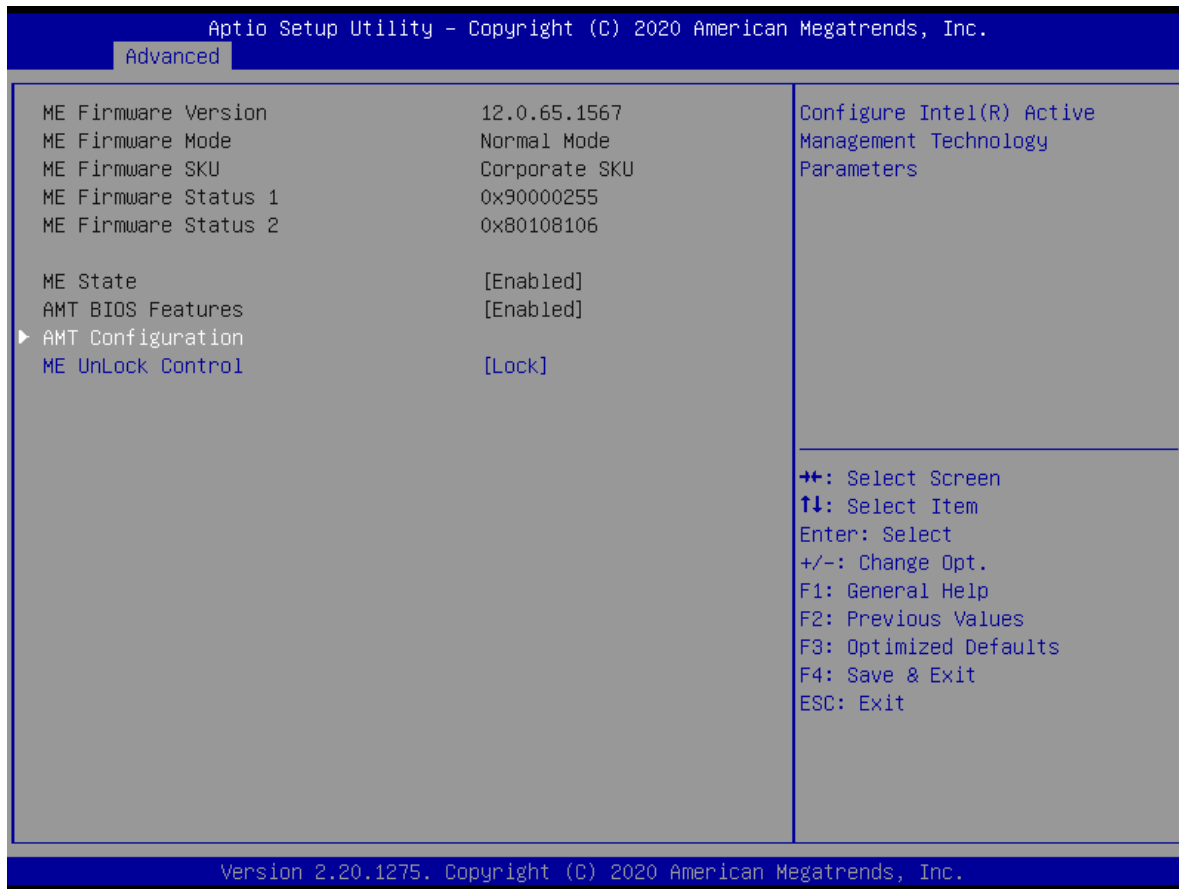

- **ME State [Enable]**  
Enable or Disable Intel ME.  
Configuration options: [Enable][Disable]
- **ME Unlock Control [Lock]**  
ME unlock switch function. This function will automatically recover setting from Unlock to Lock after power-on system.  
Configuration options: [Lock][Unlock]

## 4.3 Intel ICC



- **ICC/OD Watchdog Timer [Disabled]**

When enabled, the ICC/OC watchdog timer is exposed to OS as an ACPI device. WDT HW is always used by BIOS when clock settings are changed.

Configuration options: [Disabled][Enabled]

# BIOS - Overview and functions

## BQ370-MH3 BIOS Step

### 4.4 Trusted Computing

#### Security device settings

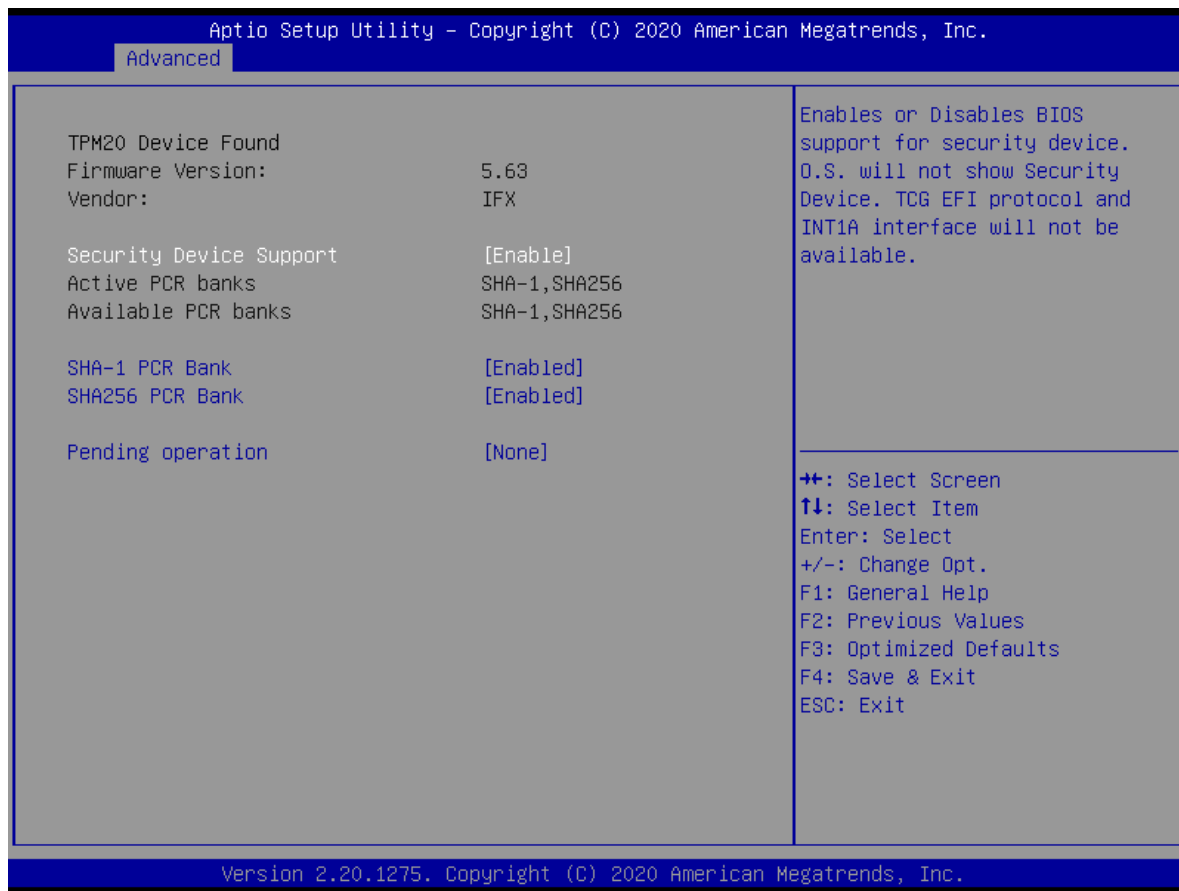

- **Security Device Support [Enable]**  
Enable or Disable BIOS support for security device.  
Configuration options: [Disable][Enable]
- **SHA-1 PCR Bank [Enabled]**  
Enable or Disable SHA-1 PCR Bank.  
Configuration options: [Disabled][Enabled]
- **SHA256 PCR Bank [Enabled]**  
Enable or Disable SHA256 PCR Bank.  
Configuration options: [Disabled][Enabled]
- **Pending Operation [None]**  
Schedule and operation for the Security Device.  
Configuration options: [None][TPM clear]

## 4.5 ACPI Settings

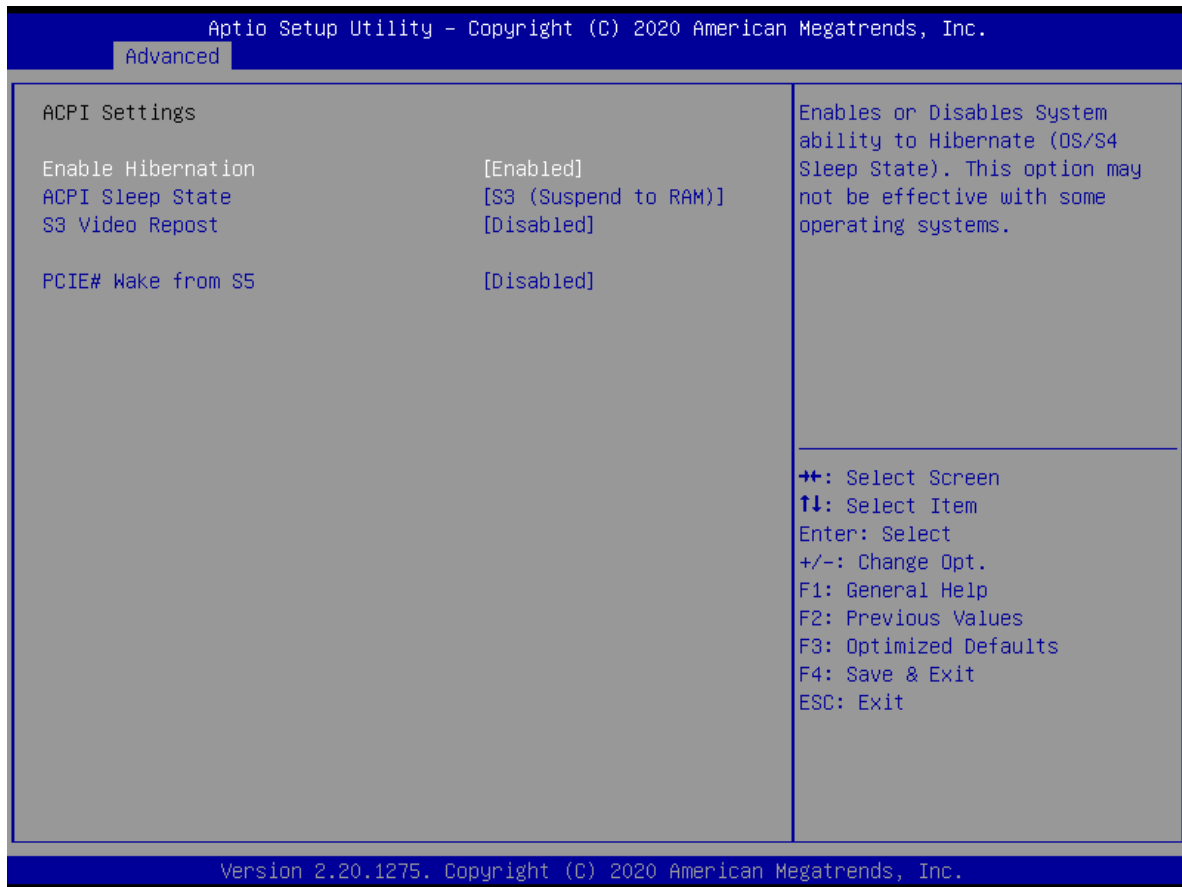

- **Enable Hibernation [Enabled]**  
 Enable or Disable system ability to Hibernation.  
 Configuration options: [Disabled][Enabled]
- **ACPI Sleep State [S3 (Suspend to RAM)]**  
 Select the highest ACPI sleep state the system will enter the SUSPEND button is press.  
 Configuration options: [Suspend Disabled][S3 (suspend to RAM)]
- **S3 Video Repost [Disabled]**  
 Enable or disable S3 video repost  
 Configuration options: [Disabled][Enabled]
- **PCIE# wake from S5 [Disabled]**  
 Enable or disable PCIE wake the system from S5.  
 Configuration options: [Disabled][Enabled]

# BIOS - Overview and functions

## BQ370-MH3 BIOS Step

### 4.6 NCT6106D Super IO configuration

Provide NCT6106D super IO configuration settings



- **WatchDog count mode [Second]**  
WatchDog count mode Selection  
Configuration options: [Second][Minute]
- **WatchDog Timeout value**  
Fill watchdog timeout value, 0 means disables

## 4.6.1 Serial Port 1 Configuration

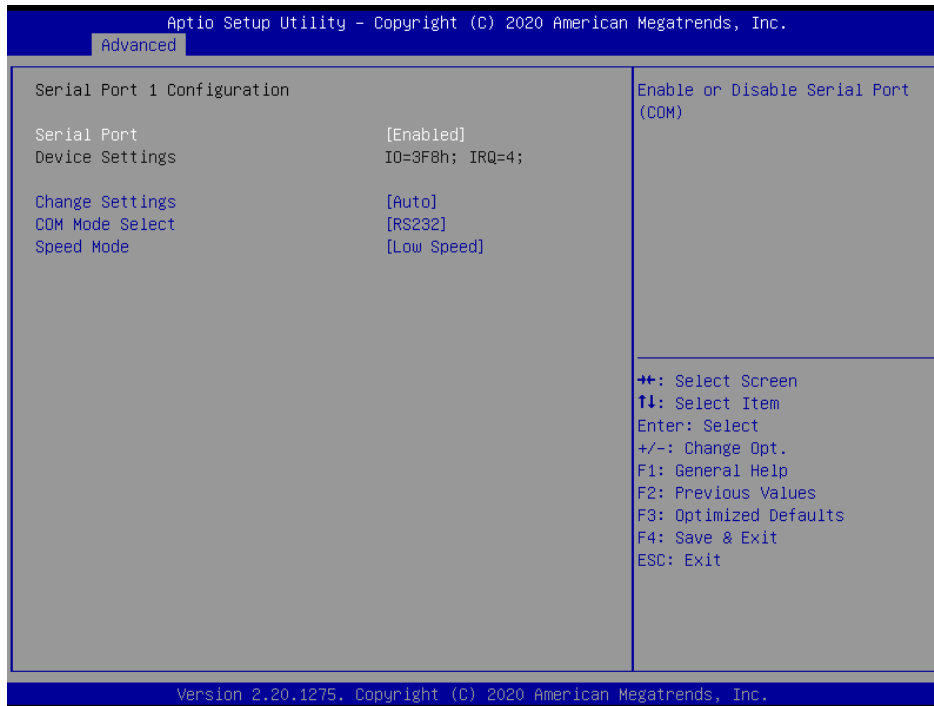

- **Serial Port [Enabled]**  
Enable or Disable serial Port (COM)  
Configuration options: [Disabled][Enabled]
- **Change Settings [Auto]**  
Select an optimal settings for super IO device  
Configuration options: as below

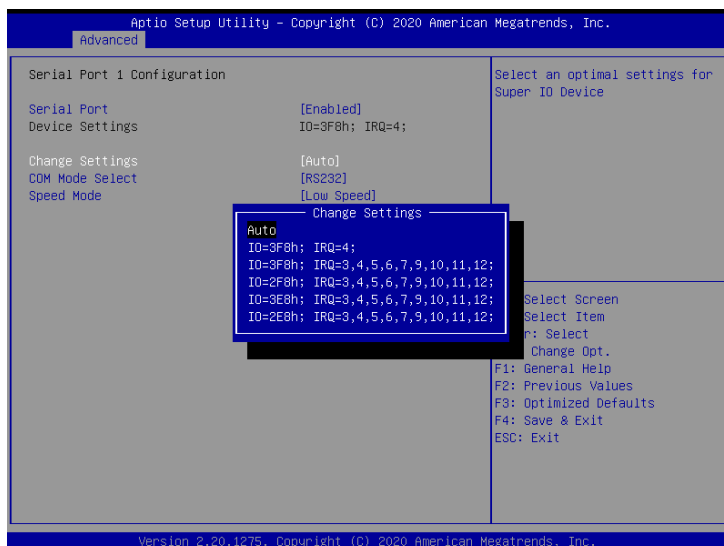

- **COM mode Select [RS232]**  
Configure the Com port mode  
Configuration options: [RS232][RS485 Half Duplex][RS485 Full Duplex]



# BIOS - Overview and functions

## BQ370-MH3 BIOS Step

- **Speed Mode [Low Speed]**

Change the speed mode for serial port (BaudRate)

Configuration options: [Low Speed][High Speed]

## 4.6.2 Serial Port 2 Configuration

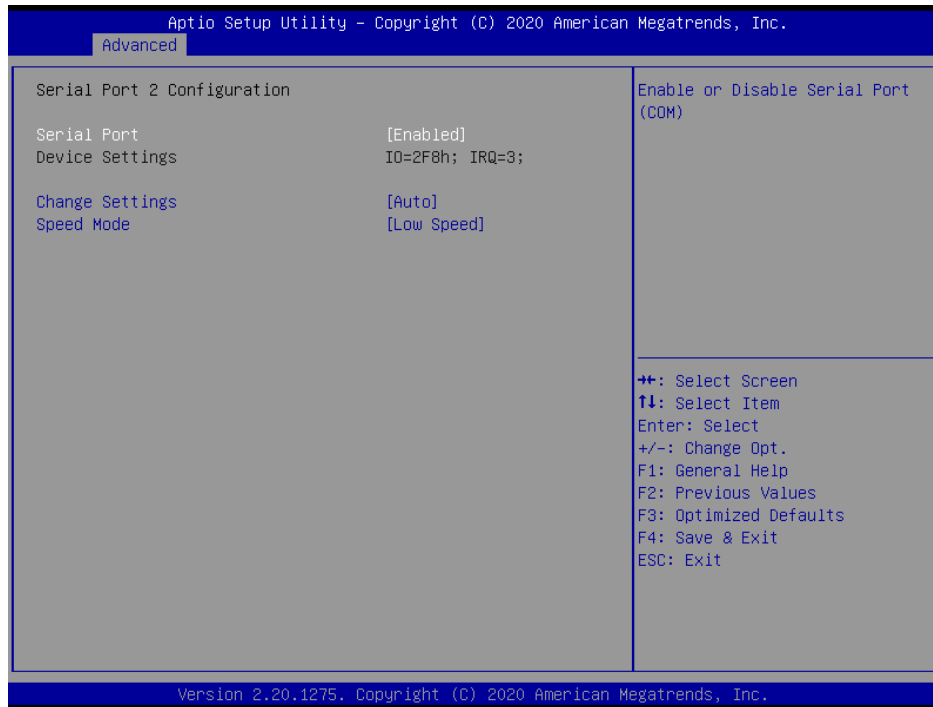

- **Serial Port [Enabled]**

Enable or Disable serial Port (COM)

Configuration options: [Disabled][Enabled]

- **Change Settings [Auto]**

Select an optimal settings for super IO device

Configuration options: as below

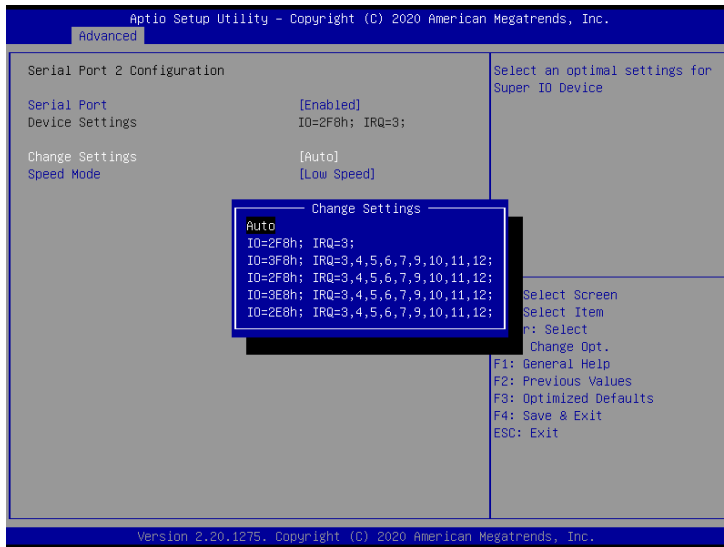

- **Speed Mode [Low Speed]**  
Change the speed mode for serial port (BaudRate)  
Configuration options: [Low Speed][High Speed]

### 4.6.3 Digital I/O Configuration

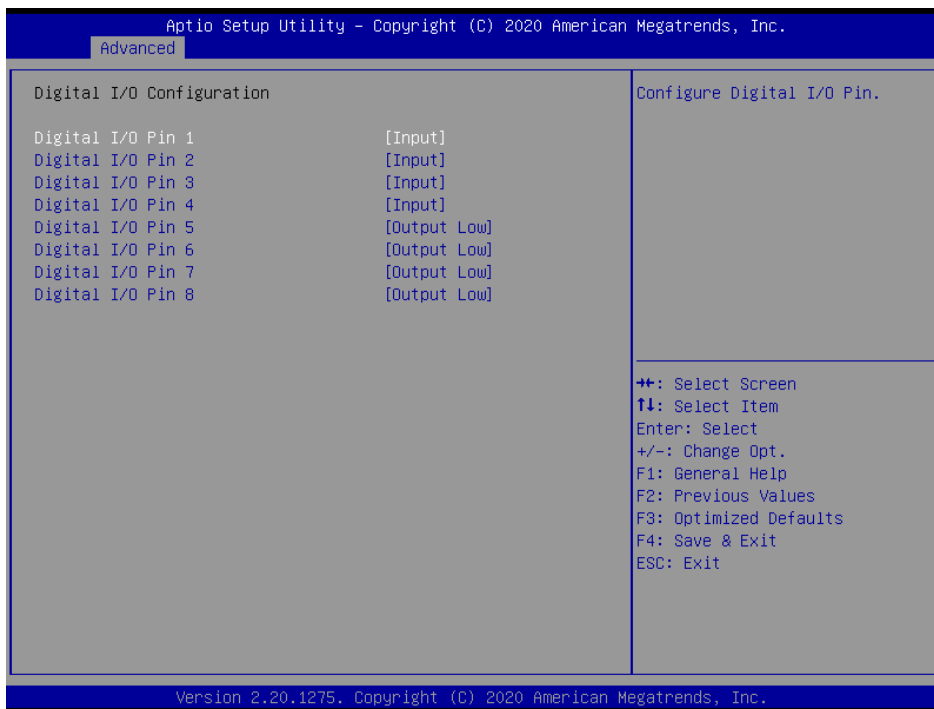

- **Digital I/O Pin1 [Input]**  
Configure Digital I/O Pin.  
Configuration options: [Input][Output High][Output Low]
- **Digital I/O Pin2 [Input]**  
Configure Digital I/O Pin.

### **BQ370-MH3 BIOS Step**

Configuration options: [Input][Output High][Output Low]

- **Digital I/O Pin3 [Input]**

Configure Digital I/O Pin.

Configuration options: [Input][Output High][Output Low]

- **Digital I/O Pin4 [Input]**

Configure Digital I/O Pin.

Configuration options: [Input][Output High][Output Low]

- **Digital I/O Pin5 [Output Low]**

Configure Digital I/O Pin.

Configuration options: [Input][Output High][Output Low]

- **Digital I/O Pin6 [Output Low]**

Configure Digital I/O Pin.

Configuration options: [Input][Output High][Output Low]

- **Digital I/O Pin7 [Output Low]**

Configure Digital I/O Pin.

Configuration options: [Input][Output High][Output Low]

- **Digital I/O Pin8 [Output Low]**

Configure Digital I/O Pin.

Configuration options: [Input][Output High][Output Low]

### **4.7 NCT6106D HW monitor**

Display Hardware monitor information

# BIOS - Overview and functions

BQ370-MH3 BIOS

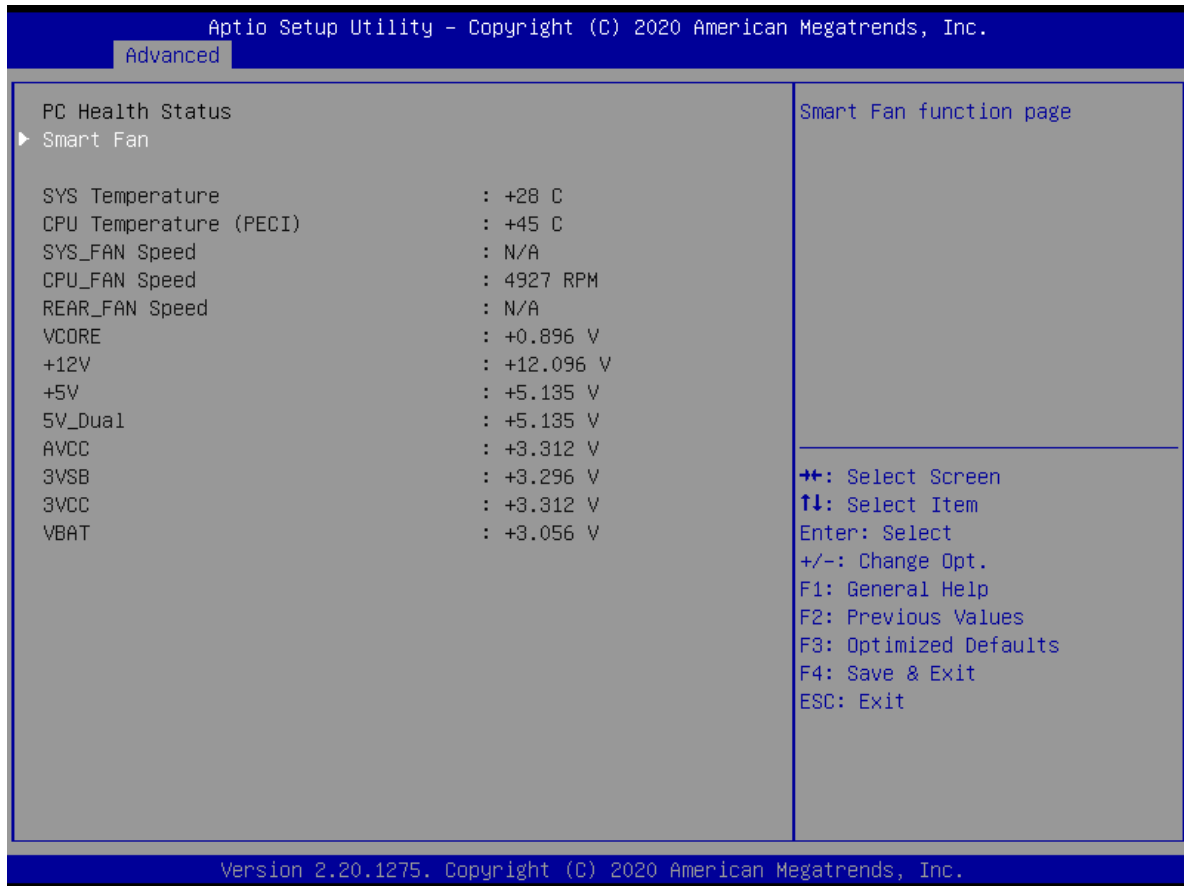

## 4.7.1 Smart FAN

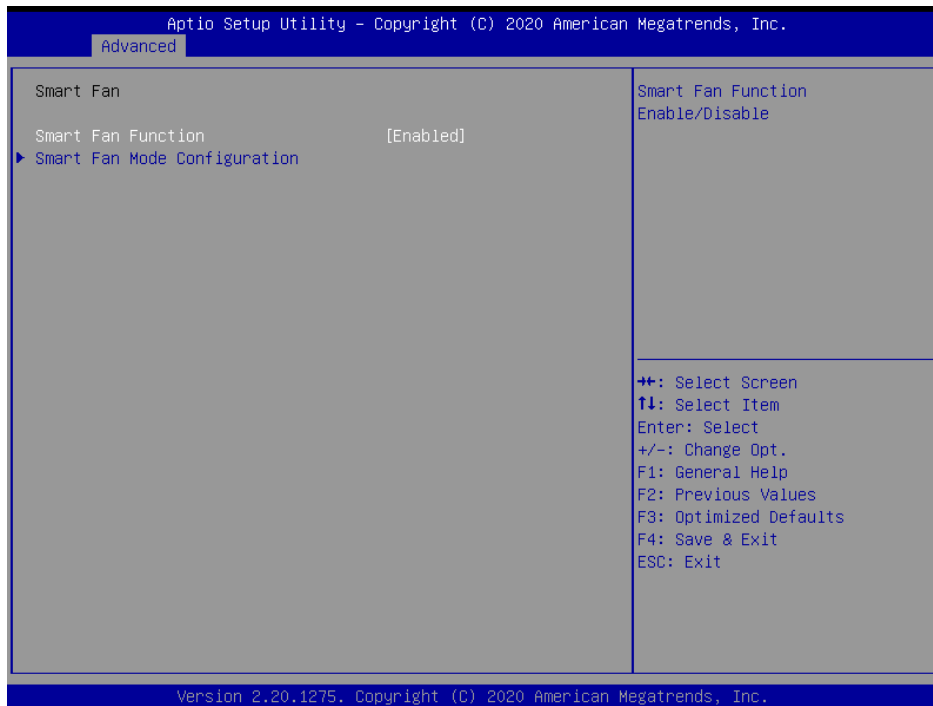

- Smart FAN Function [Enabled]

# BIOS - Overview and functions

## BQ370-MH3 BIOS Step

Smart fan function Enable/Disabled

Configuration options: [Disabled][Enabled]

### 4.7.1.1 Smart FAN mode Configuration

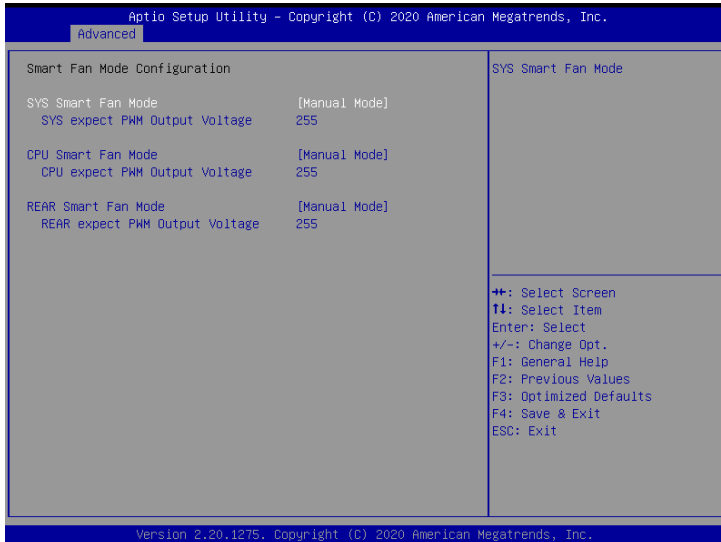

- **SYS Smart Fan Mode [Manual Mode]**  
SYS Smart FAN Mode selection  
Configuration options: [Manual Mode][Thermal Cruise Mode][SMART FAN IV Mode]
- **CPU Smart Fan Mode [Manual Mode]**  
CPU Smart FAN Mode selection  
Configuration options: [Manual Mode][Thermal Cruise Mode][SMART FAN IV Mode]
- **REAR Smart Fan Mode [Manual Mode]**  
CPU Smart FAN Mode selection  
Configuration options: [Manual Mode][Thermal Cruise Mode][SMART FAN IV Mode]

## 4.8 Preheat Function Configuration

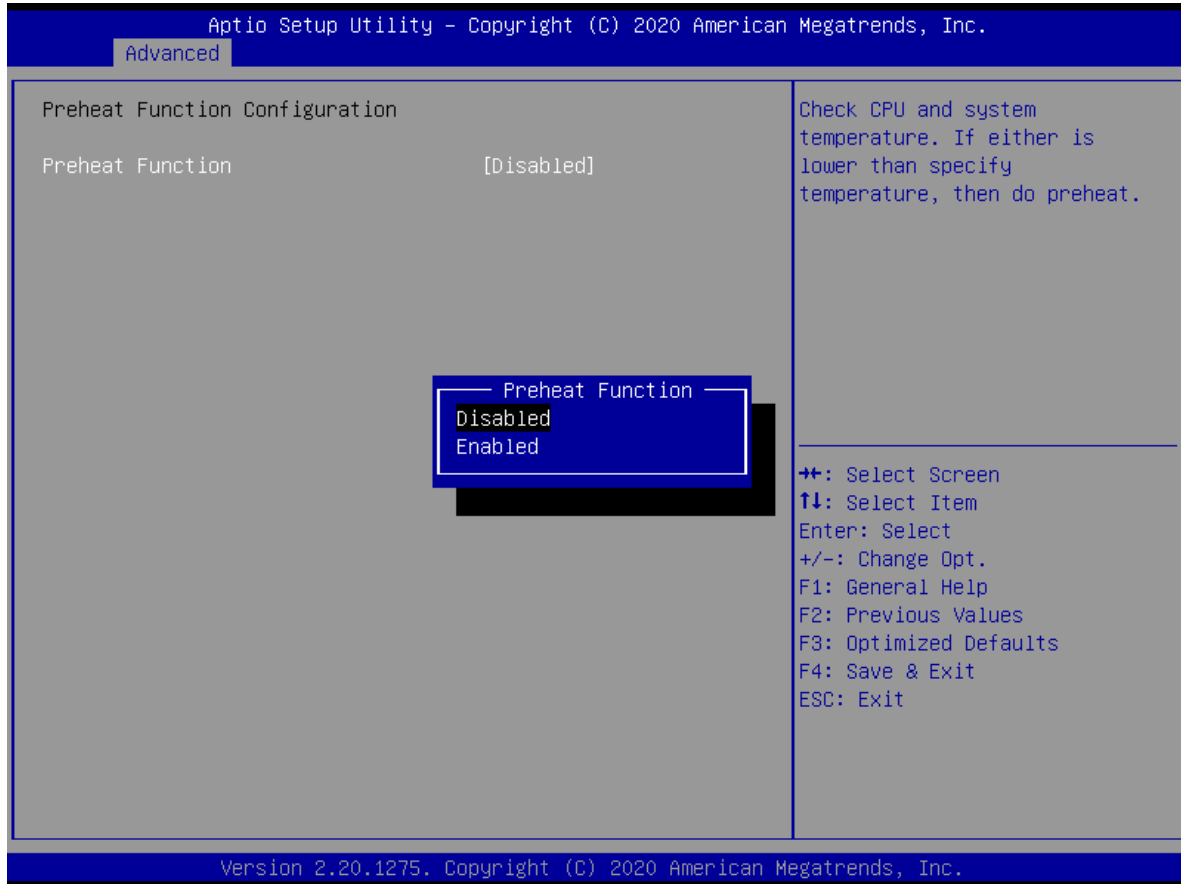

- **Preheat Function [Disabled]**  
Check CPU and system temperature. If either is lower than specific temperature, then do preheat.  
Configuration options: [Disabled][Enabled]

# BIOS - Overview and functions

## BQ370-MH3 BIOS Step

### 4.9 S5 RTC wake settings

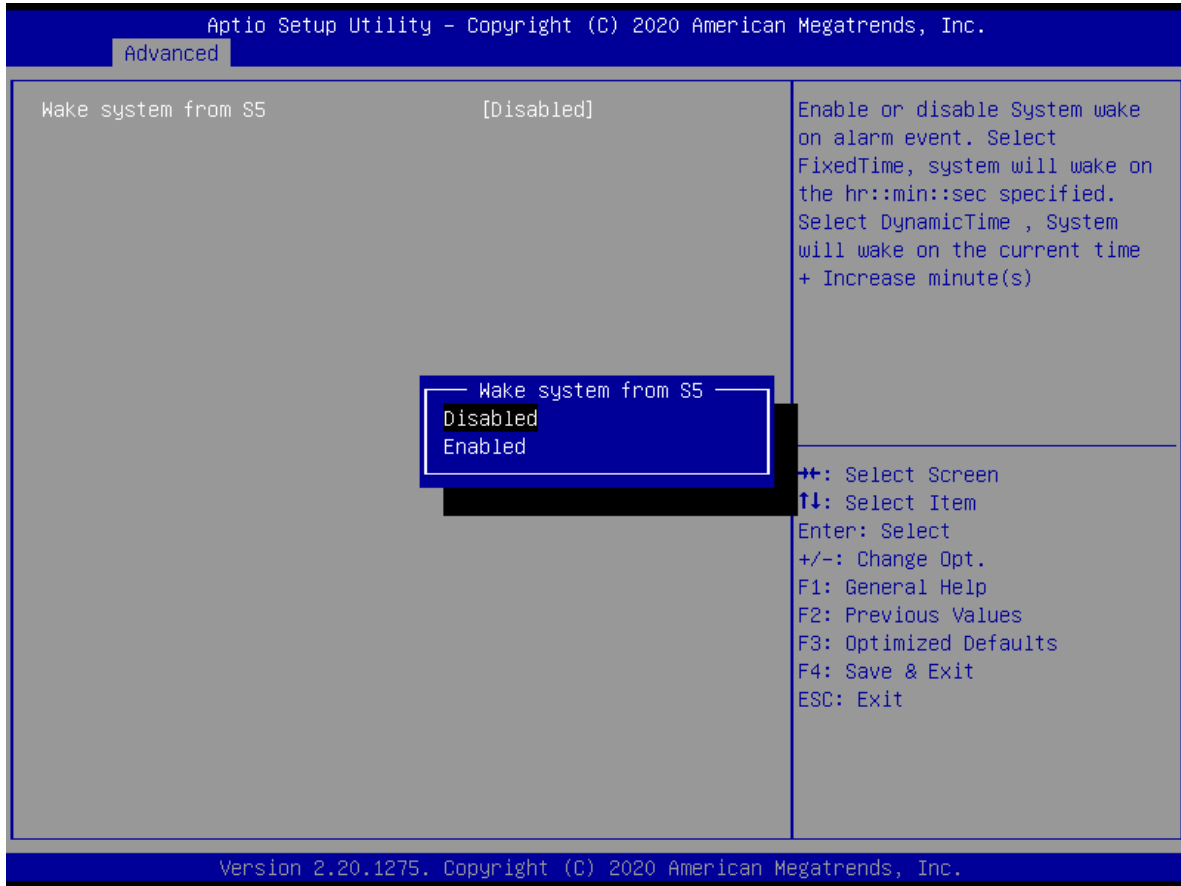

- **Wake system from S5 [Disabled]**  
Enabled or Disabled system wake on alarm event  
Configuration options: [Disabled][Enabled]

## 4.10 Serial Port Console Redirection

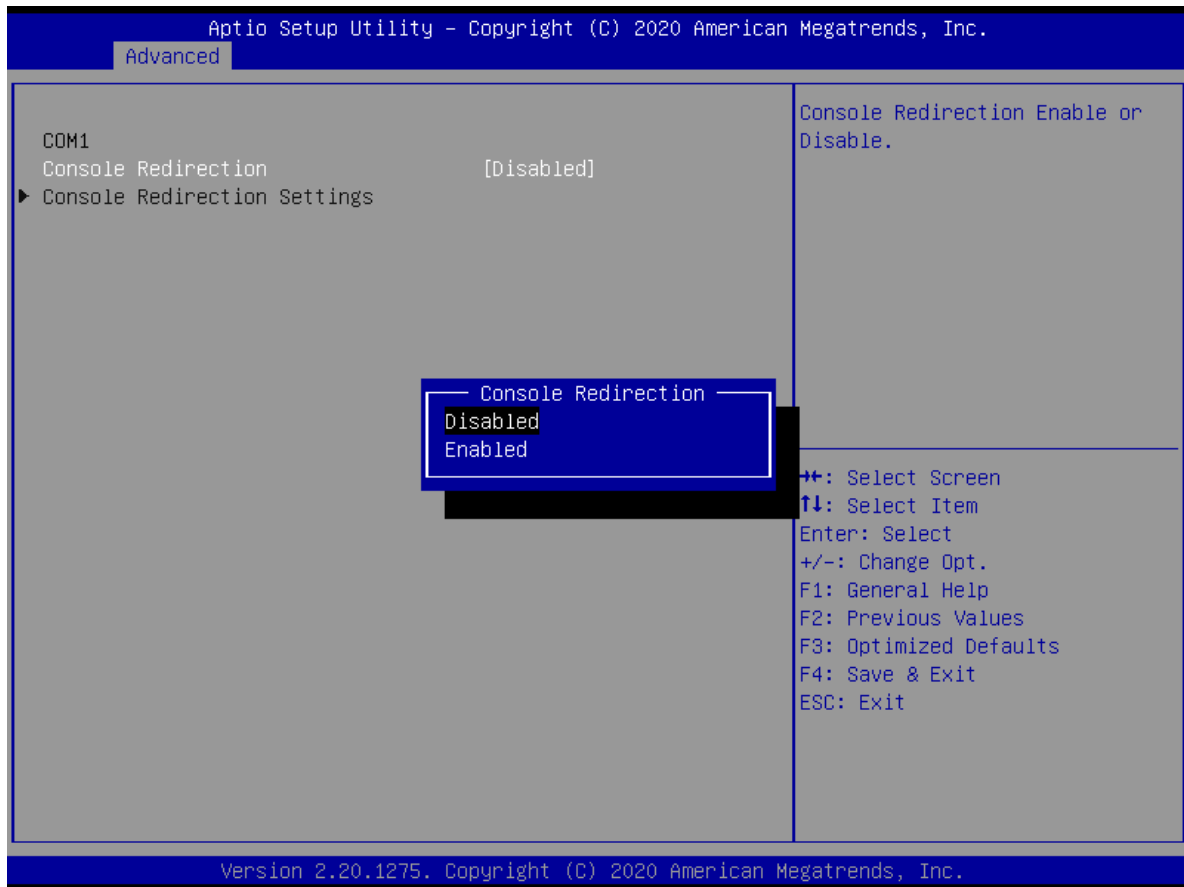

- **Console Redirection [Disabled]**  
Enabled or Disabled Console Redirection  
Configuration options: [Disabled][Enabled]



# BIOS - Overview and functions

## BQ370-MH3 BIOS Step

### 4.11 Intel TXT information

Display Intel TXT information

The screenshot displays the 'Advanced' tab of the Aptio Setup Utility. The main content area is titled 'Intel TXT Information' and contains the following data:

Chipset	Production Fused
BiosAcm	Production Fused
Cpu Txt	Supported
Error Code	None
Class Code	None
Major Code	None
Minor Code	None

Below the information table, a legend lists the navigation keys:

- ←→: Select Screen
- ↑↓: Select Item
- Enter: Select
- +/-: Change Opt.
- F1: General Help
- F2: Previous Values
- F3: Optimized Defaults
- F4: Save & Exit
- ESC: Exit

The BIOS title bar at the top reads 'Aptio Setup Utility - Copyright (C) 2020 American Megatrends, Inc.' and the bottom status bar reads 'Version 2.20.1275. Copyright (C) 2020 American Megatrends, Inc.'

## 4.12 USB Configuration

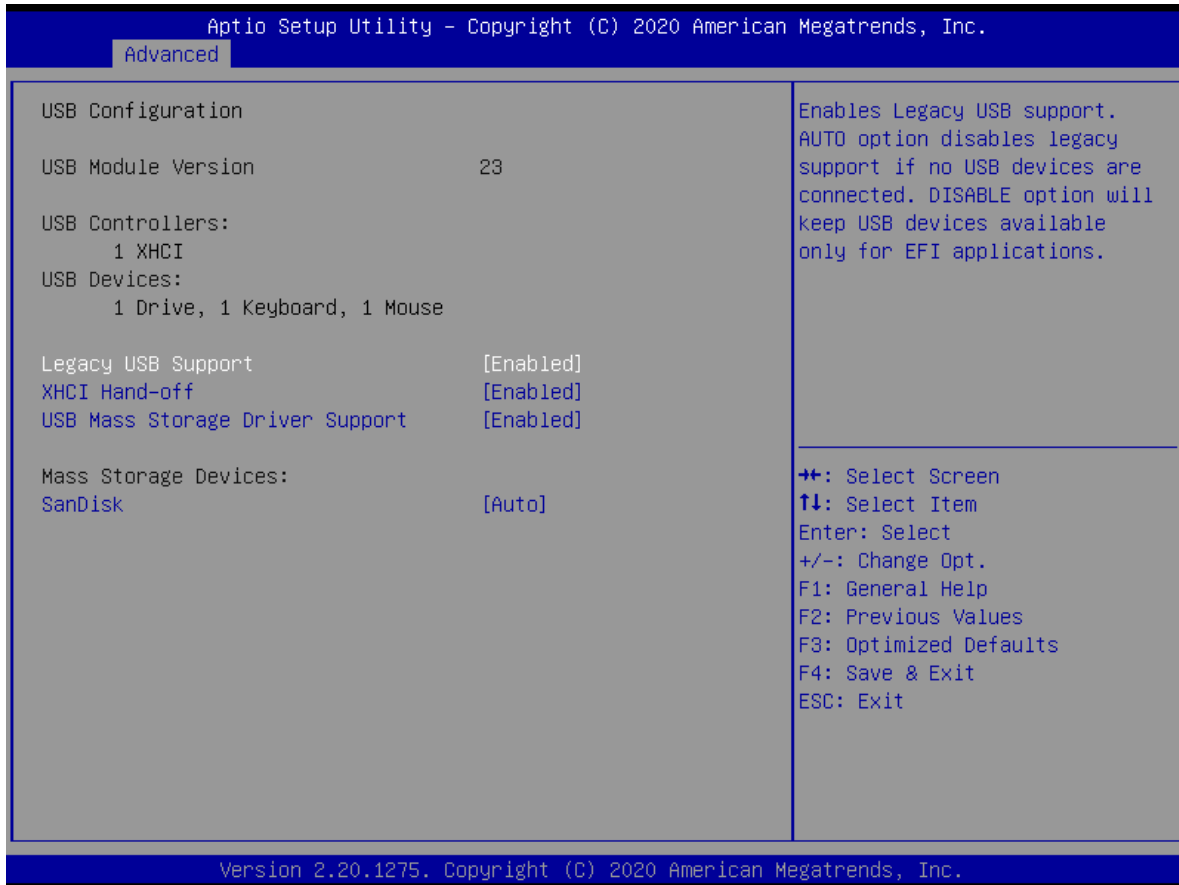

- **Legacy USB Support [Enabled]**  
Enabled Legacy USB Support. Auto Option disables legacy support if no USB devices are connected. Disabled option will keep USB devices available only for EFI application.  
Configuration options: [Enabled][Disabled][Auto]
- **XHCI Hand-off [Enabled]**  
This is a workaround for Oses without XHCI hand-off support. This XHCI ownership change should be claimed by XHCI drivers  
Configuration options: [Enabled][Disabled]
- **USB Mass storage Driver Support[Enabled]**  
Enabled or Disabled USB Mass storage driver support.  
Configuration options: [Disabled][Enabled]
- **Mass Storage Devices: It depends on devices selection.**

# BIOS - Overview and functions

## BQ370-MH3 BIOS Step

### 4.13 CSM (Compatibility Support Module) Configuration

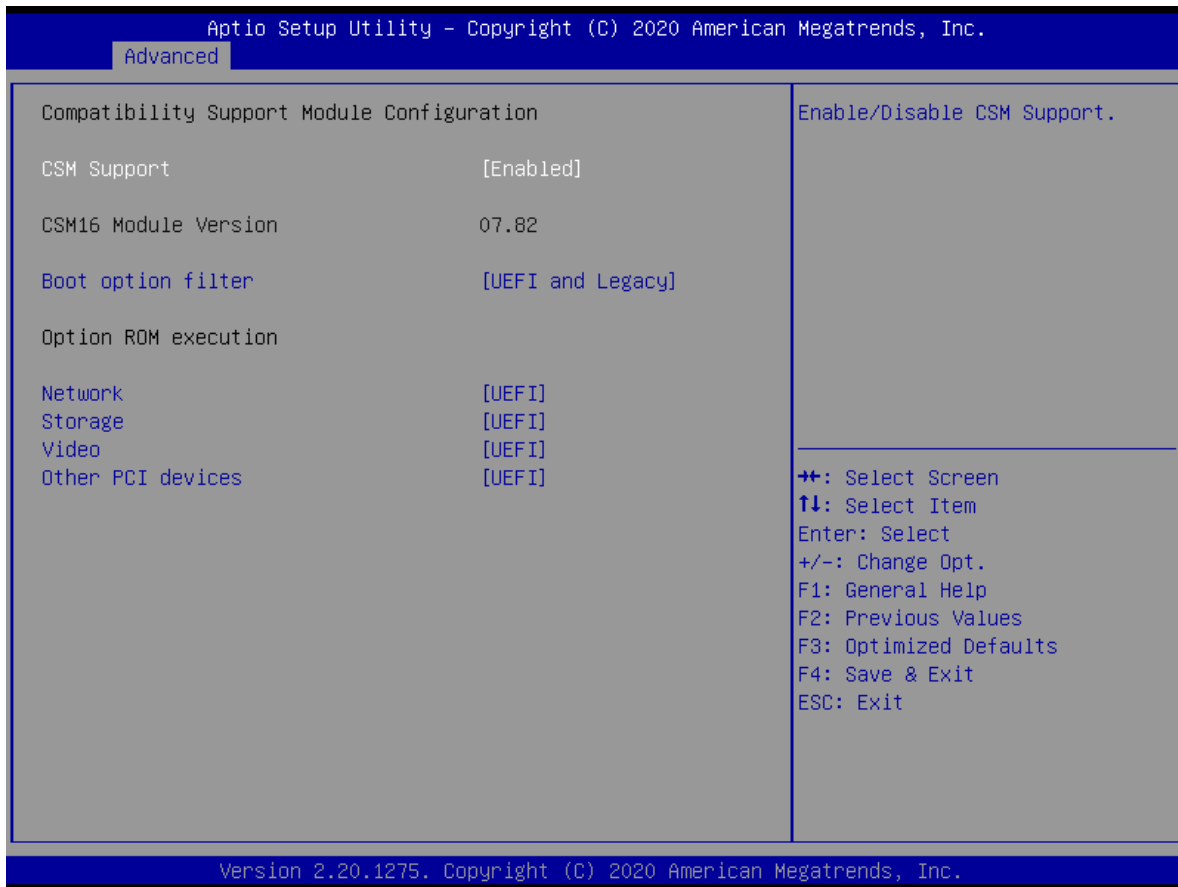

- **CSM Support [Enabled]**  
Enabled or disabled CSM Support  
Configuration options: [Disabled][Enabled]
- **Boot option Filter [UEFI and Legacy]**  
This option controls Legacy/UEFI ROMs Priority  
Configuration options: [UEFI and Legacy][Legacy Only][UEFI Only]
- **Network [UEFI]**  
Control the execution of UEFI and Legacy PXE OpROM  
Configuration options: [Do not launch][UEFI][Legacy]
- **Storage [UEFI]**  
Control the execution of UEFI and Legacy Storage OpROM  
Configuration options: [Do not launch][UEFI][Legacy]
- **Video [UEFI]**  
Control the execution of UEFI and Legacy Video OpROM  
Configuration options: [Do not launch][UEFI][Legacy]
- **Other PCI devices [UEFI]**  
Determine OpROM execution policy for devices other than Network, Storage, or Video.  
Configuration options: [Do not launch][UEFI][Legacy]

## 4.14 NVMe Configuration

### Display NVMe controller or Drive information

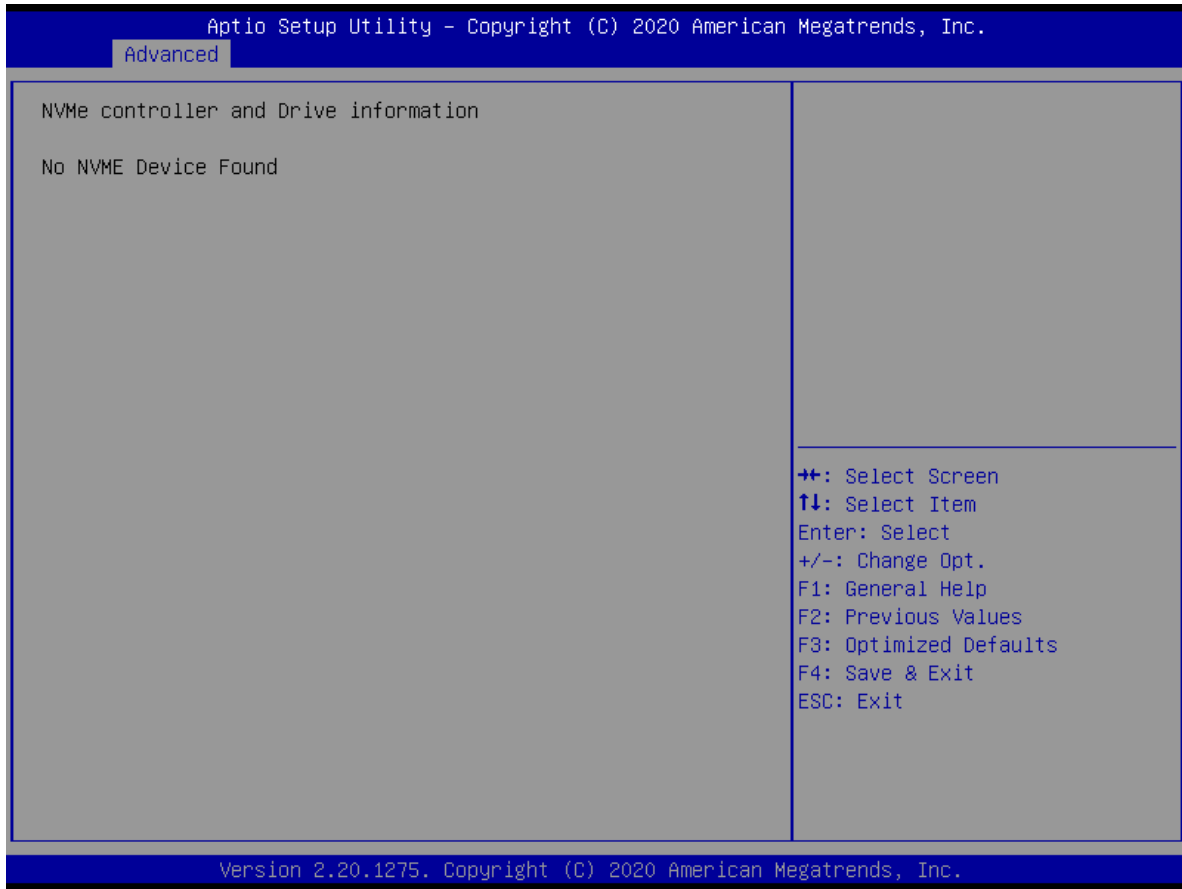

# BIOS - Overview and functions

## BQ370-MH3 BIOS Step

### 4.15 Network Stack Configuration

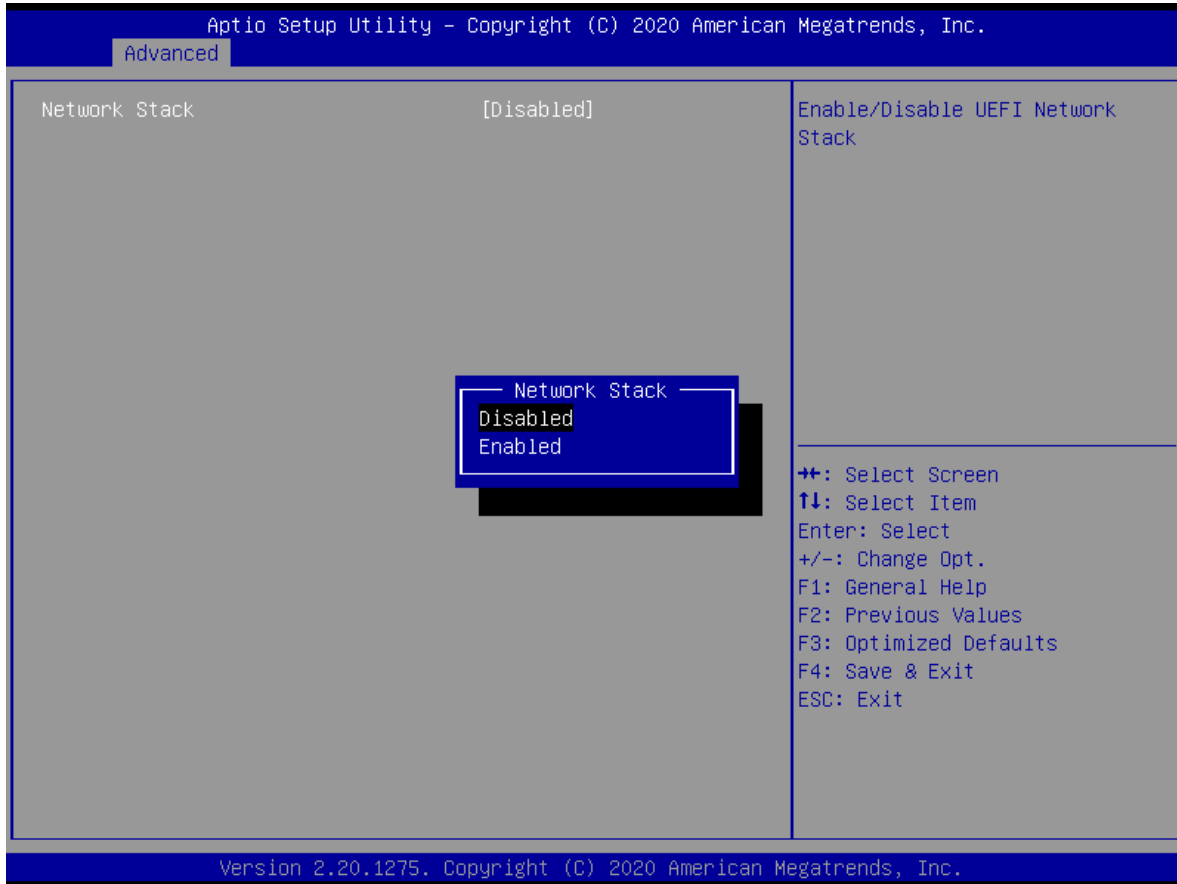

- **Network Stack [Disabled]**  
Enabled or disabled UEFI Network Stack  
Configuration options: [Disabled][Enabled]

## 5 Chipset

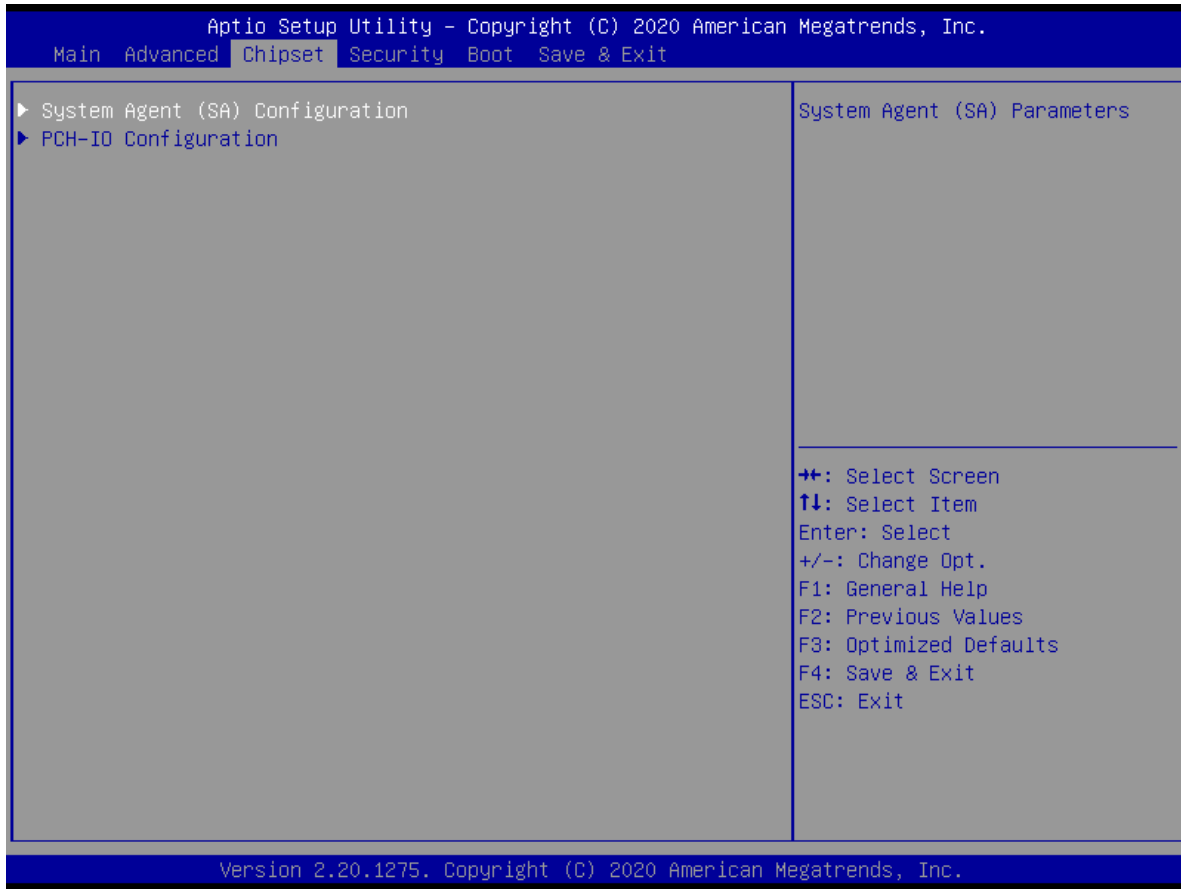

## BQ370-MH3 BIOS Step

### 5.1 System Agent (SA) Configuration

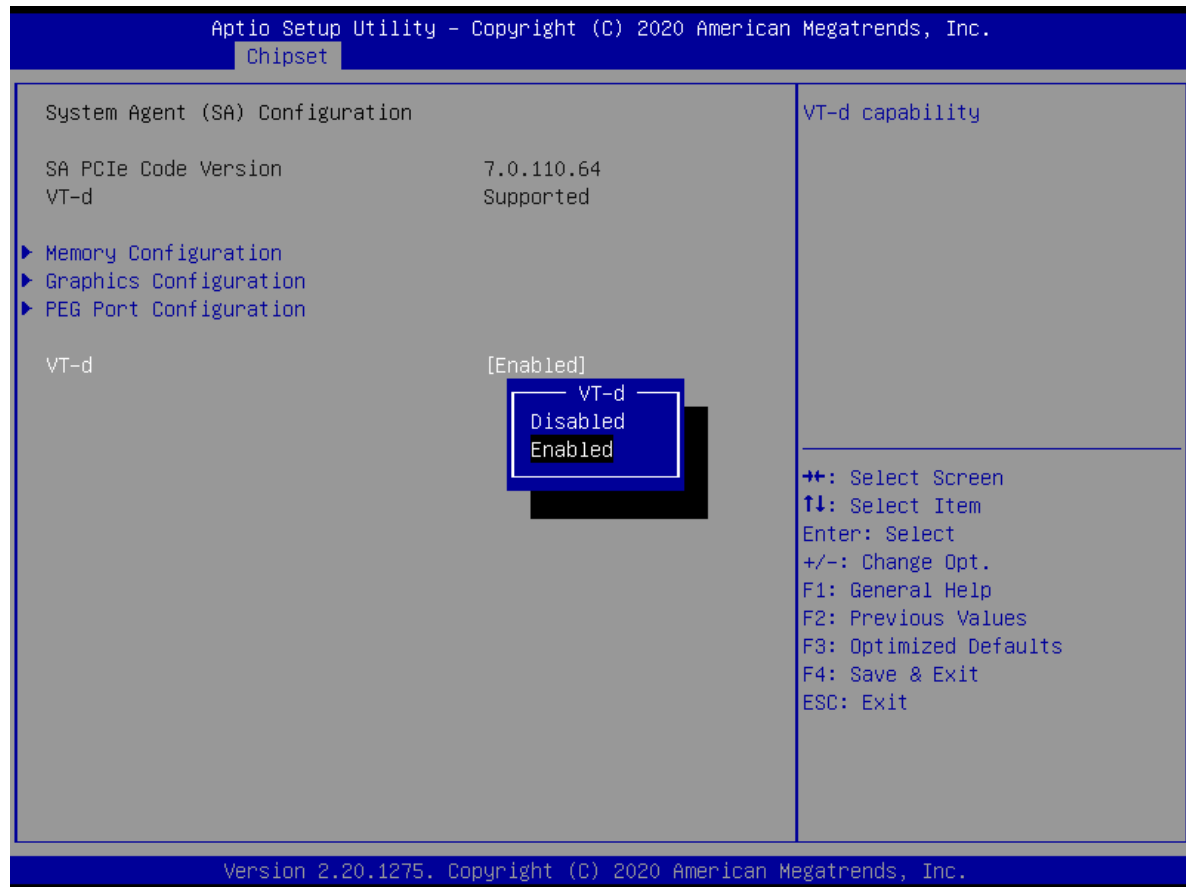

- **VT-d [Enabled]**  
VT-d capability  
Configuration options: [Disabled][Enabled]

#### 5.1.1 Memory configuration

Display memory information

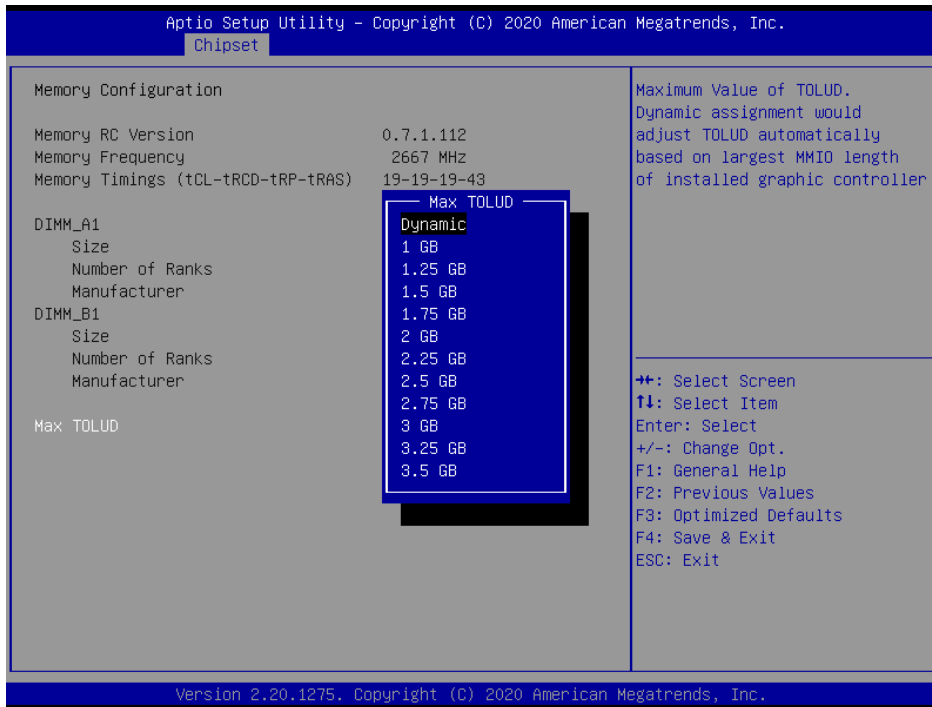

- **Max TOLUD [Dynamic]**  
Maximum value of TOLUD.  
Configuration options: As above picture

## 5.1.2 Graphic Configuration

Graphic configuration settings

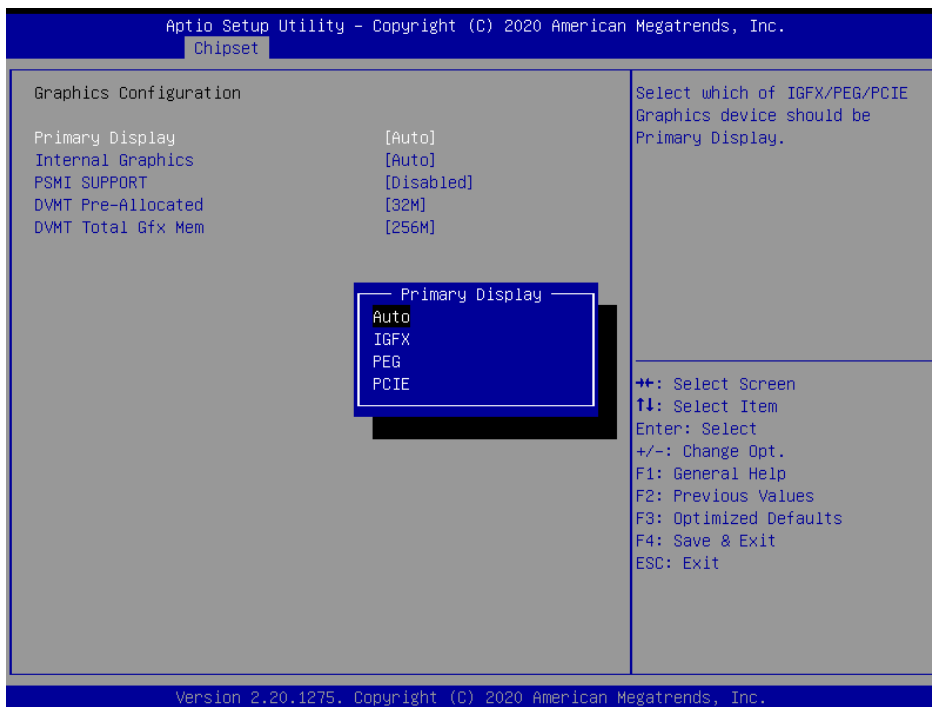



# BIOS - Overview and functions

## BQ370-MH3 BIOS Step

- **Primary Display[Auto]**

Select which of IGFX/PEG/PCIE graphic device should be primary display or select SG for switchable GFx.

Configuration options: [Auto][IGFX][PEG][PCIE]

- **Internal Graphics [Auto]**

Keep IGFX enabled based on the setup options

Configuration options: [Auto][Disabled][Enabled]

- **PSMI Support [Disabled]**

Enable or disable PSMI

Configuration options: [Disabled][Enabled]

- **DVMT Pre-Allocated [32M]**

Select DVMT 5.0 Pre-allocated (Fixed) Graphics memory size used by the internal graphics device.

Configuration options: As below picture

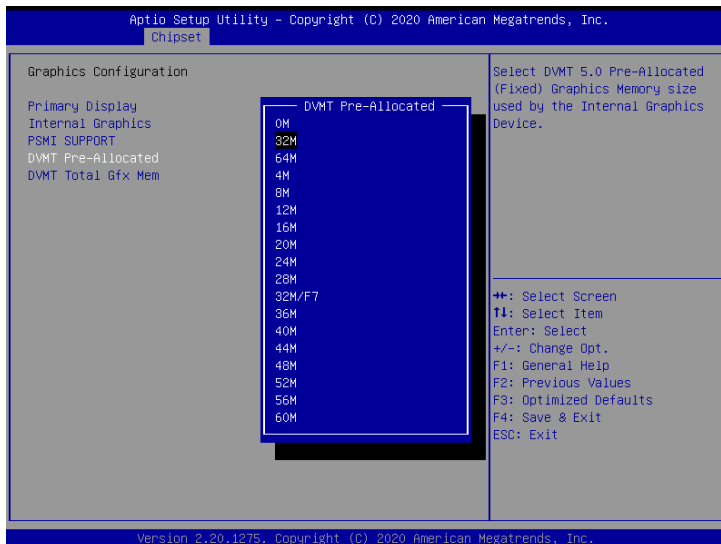

- **DVMT Total Gfx Mem [256M]**

Select DVMT 5.0 Total graphic memory size used by the internal graphic device

Configuration options: [128M][256M][Max]

## 5.1.3 PEG Port Configuration

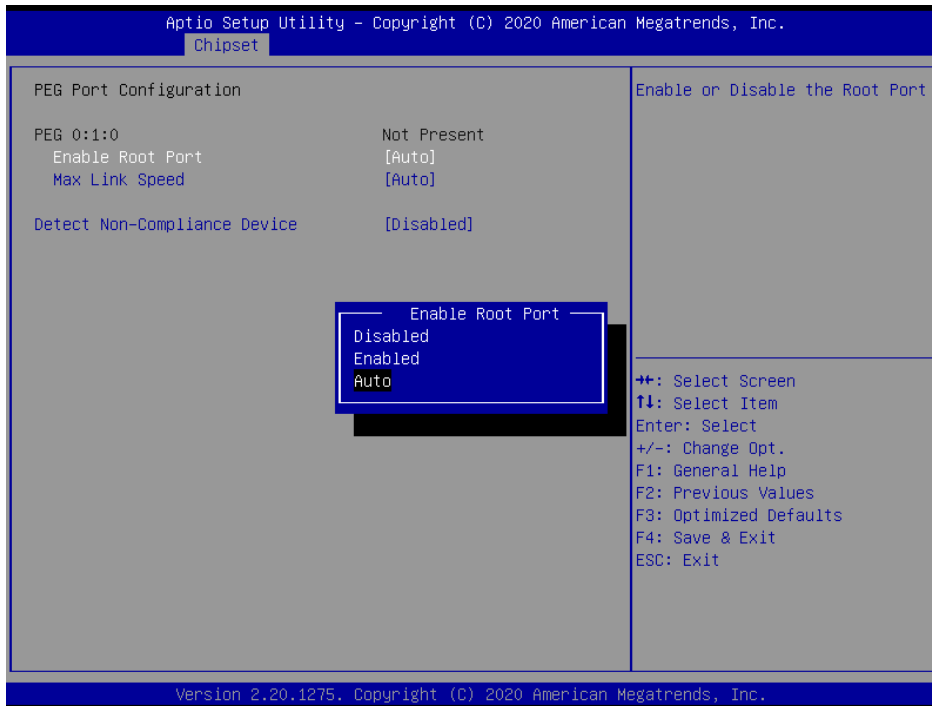

- **Enable Root Port [Auto]**  
Enable or Disable the Root Port  
Configuration options: [Disabled][Enabled][Auto]
- **Max Link Speed [Auto]**  
Configure PEG 0 :1 :0 Max Speed  
Configuration options: [Auto][Gen1][Gen2][Gen3]
- **Detect Non-Compliance Device [Disabled]**  
Detect Non-Compliance PCI Express Device in PEG  
Configuration options: [Disabled][Enabled]

# BIOS - Overview and functions

## BQ370-MH3 BIOS Step 5.2 PCH-IO configuration

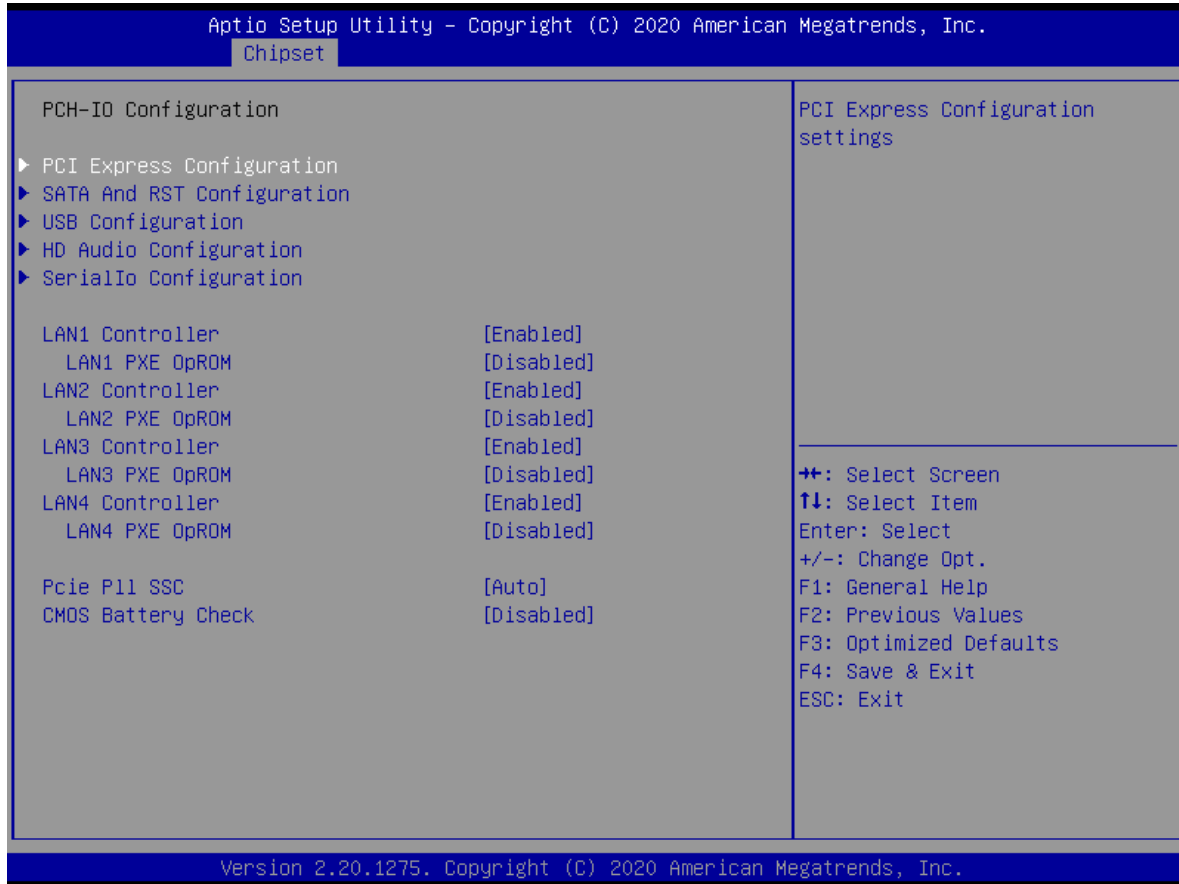

- **Lan1 Controller [Enabled]**  
Enable or Disable onboard Lan1  
Configuration options: [Disabled][Enabled]
- **Lan1 PXE DpROM [Disabled]**  
Enable or Disable boot option for Lan1 Controller  
Configuration options: [Disabled][Enabled]
- **Lan2 Controller [Enabled]**  
Enable or Disable onboard Lan2  
Configuration options: [Disabled][Enabled]
- **Lan2 PXE DpROM [Disabled]**  
Enable or Disable boot option for Lan2 Controller  
Configuration options: [Disabled][Enabled]
- **Lan3 Controller [Enabled]**  
Enable or Disable onboard Lan3  
Configuration options: [Disabled][Enabled]
- **Lan3 PXE DpROM [Disabled]**  
Enable or Disable boot option for Lan3 Controller  
Configuration options: [Disabled][Enabled]

- **Lan4 Controller [Enabled]**  
Enable or Disable onboard Lan4  
Configuration options: [Disabled][Enabled]
- **Lan4 PXE DpROM [Disabled]**  
Enable or Disable boot option for Lan4 Controller  
Configuration options: [Disabled][Enabled]
- **Pcie P11 SSC [Auto]**  
Pcie P11 SCC percentage: Auto – Keep HW default, no BIOS override. Range is 0.0%-2.0%.  
Configuration options: As below picture

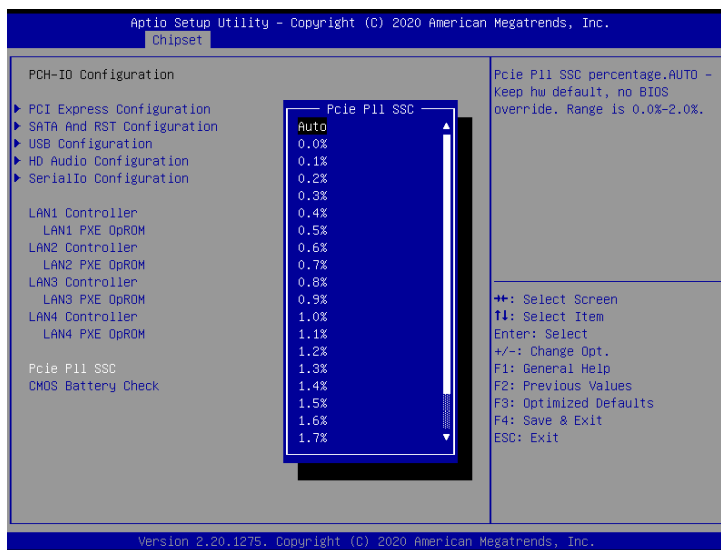

- **CMOS Battery Check [Disabled]**  
Enabled/ Disabled CMOS Battery Check function  
Configuration options: [Disabled][Enabled]

## BQ370-MH3 BIOS Step

### 5.2.1 PCI Express Configuration

#### 5.2.1.1 PCI Express Root Port 3 (M.2 KeyE) (M2\_1)

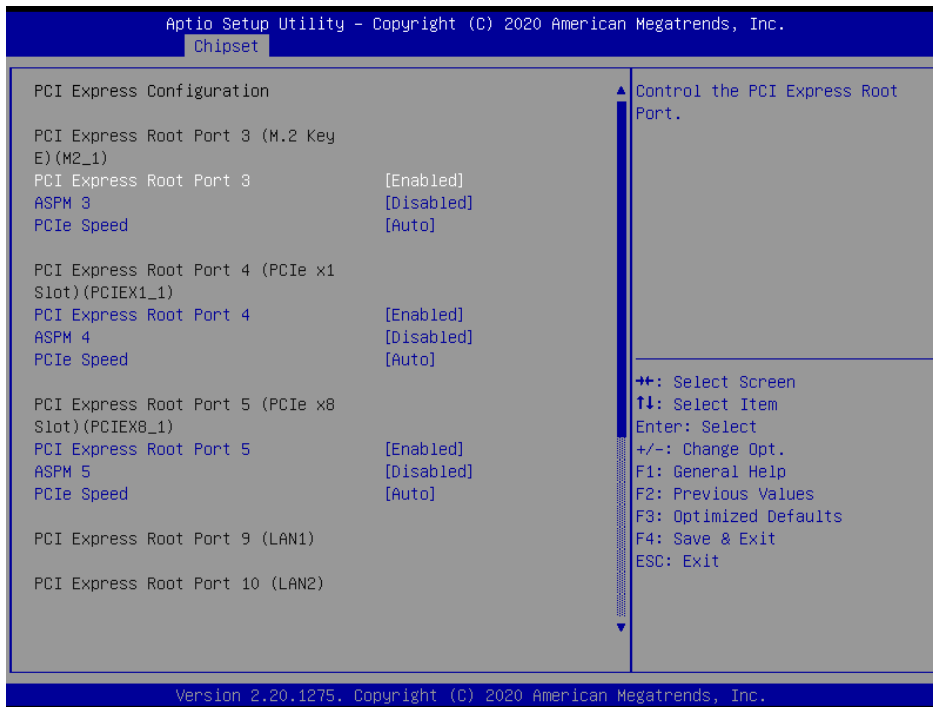

- **PCI Express Root Port 3 [Enabled]**  
Control the PCI Express Root Port  
Configuration options: [Disabled][Enabled]
- **ASPM 3 [Disabled]**  
Set the ASPM level: Force L0s- Force all links to L0s State; Auto- BIOS auto configure; Disabled- Disables ASPM  
Configuration options: [Disabled][L0s][L1][L0sL1][Auto]
- **PCIe Speed [Auto]**  
Select PCI Express Port speed  
Configuration options: [Auto][Gen1][Gen2][Gen3]

## 5.2.1.2 PCI Express Root Port 4 (PCIe x1 Slot) (PCIEX1\_1)

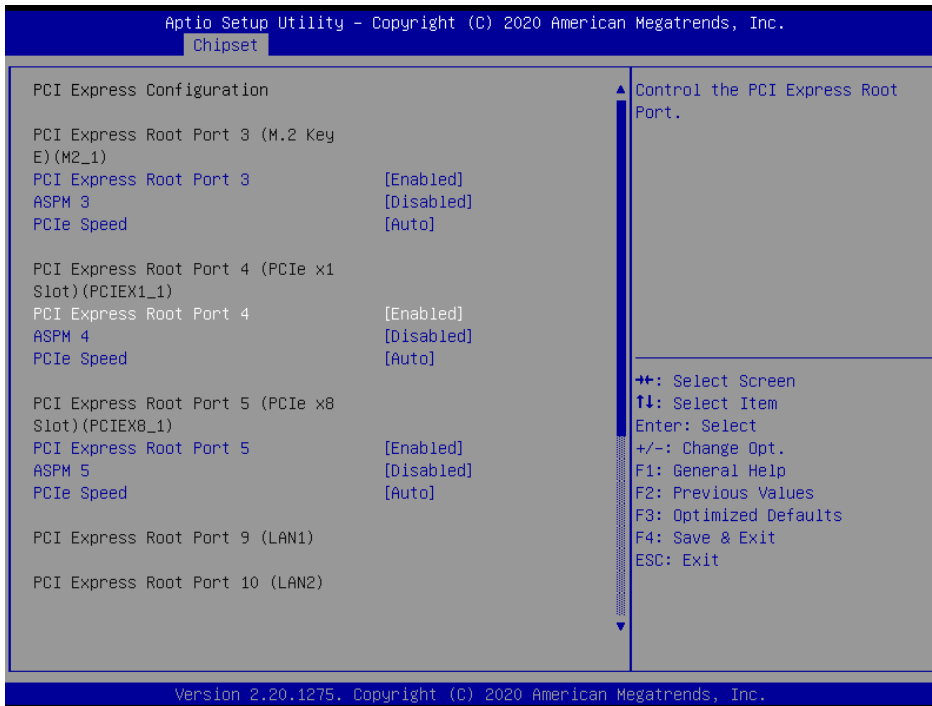

- **PCI Express Root Port 4 [Enabled]**  
Control the PCI Express Root Port  
Configuration options: [Disabled][Enabled]
- **ASPM 4 [Disabled]**  
Set the ASPM level: Force L0s- Force all links to L0s State; Auto- BIOS auto configure;  
Disabled- Disables ASPM  
Configuration options: [Disabled][L0s][L1][L0sL1][Auto]
- **PCIe Speed [Auto]**  
Select PCI Express Port speed  
Configuration options: [Auto][Gen1][Gen2][Gen3]

## BQ370-MH3 BIOS Step

### 5.2.1.3 PCI Express Root Port 5 (PCIe x8 Slot) (PCIEX8\_1)

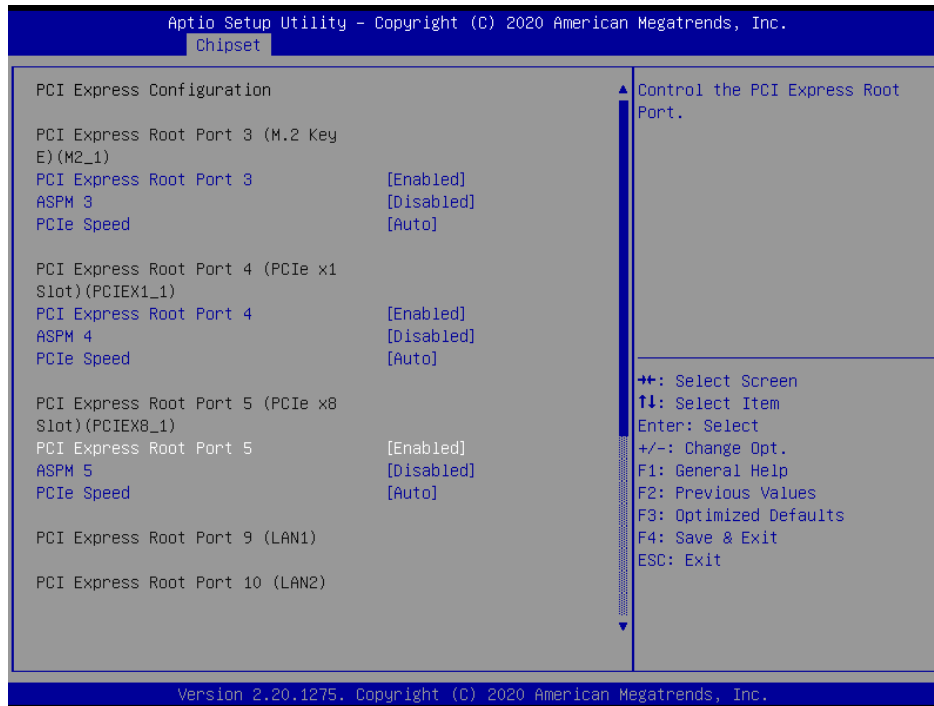

- **PCI Express Root Port 5 [Enabled]**  
Control the PCI Express Root Port  
Configuration options: [Disabled][Enabled]
- **ASPM 5 [Disabled]**  
Set the ASPM level: Force L0s- Force all links to L0s State; Auto- BIOS auto configure;  
Disabled- Disables ASPM  
Configuration options: [Disabled][L0s][L1][L0sL1][Auto]
- **PCIe Speed [Auto]**  
Select PCI Express Port speed  
Configuration options: [Auto][Gen1][Gen2][Gen3]

## 5.2.1.4 PCI Express Root Port 13 (M.2 KeyM) (M2\_2)

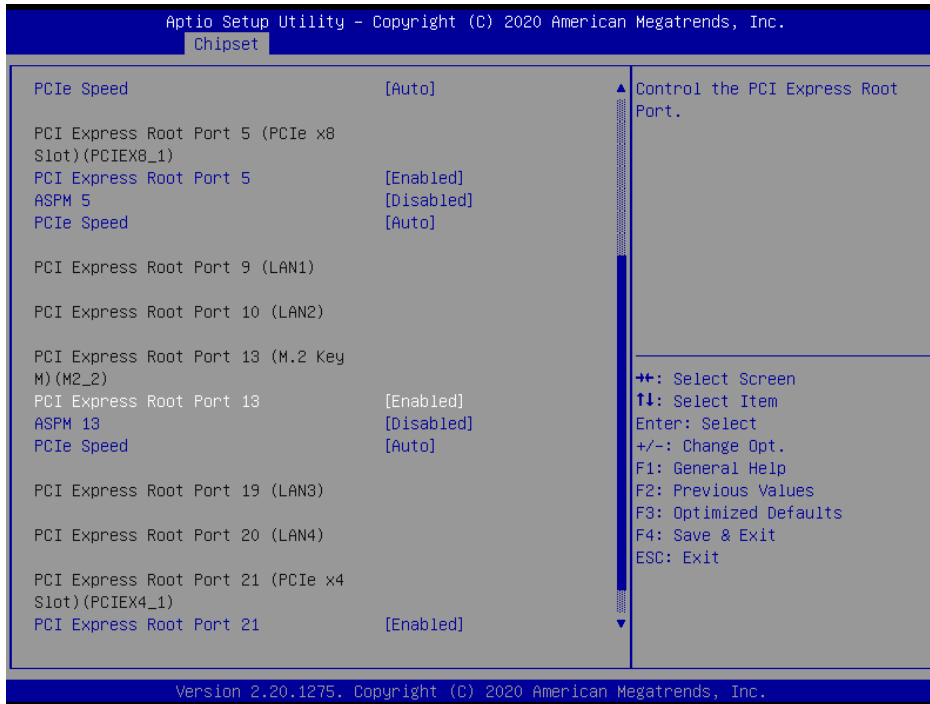

- **PCI Express Root Port 13 [Enabled]**  
Control the PCI Express Root Port  
Configuration options: [Disabled][Enabled]
- **ASPM 13 [Disabled]**  
Set the ASPM level: Force L0s- Force all links to L0s State; Auto- BIOS auto configure;  
Disabled- Disables ASPM  
Configuration options: [Disabled][L0s][L1][L0sL1][Auto]
- **PCIe Speed [Auto]**  
Select PCI Express Port speed  
Configuration options: [Auto][Gen1][Gen2][Gen3]



# BIOS - Overview and functions

## BQ370-MH3 BIOS Step

### 5.2.1.5 PCI Express Root Port 21 (PCIe x4 Slot) (PCIEX4\_1)

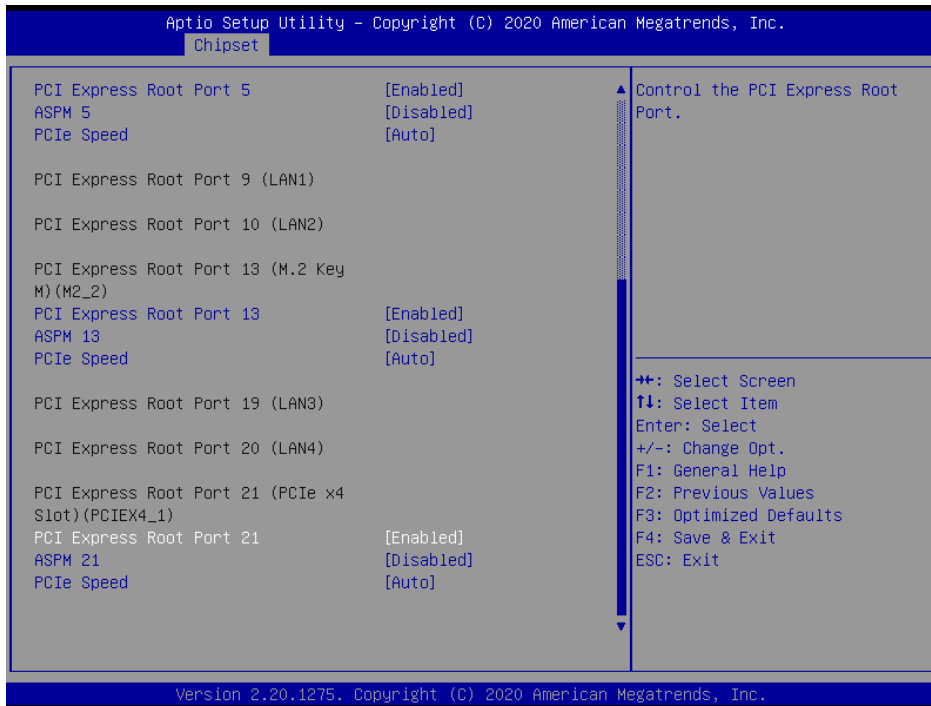

- **PCI Express Root Port 21 [Enabled]**  
Control the PCI Express Root Port  
Configuration options: [Disabled][Enabled]
- **ASPM 21 [Disabled]**  
Set the ASPM level: Force L0s- Force all links to L0s State; Auto- BIOS auto configure; Disabled- Disables ASPM  
Configuration options: [Disabled][L0s][L1][L0sL1][Auto]
- **PCIe Speed [Auto]**  
Select PCI Express Port speed  
Configuration options: [Auto][Gen1][Gen2][Gen3]

## 5.2.2 SATA and RST Configuration

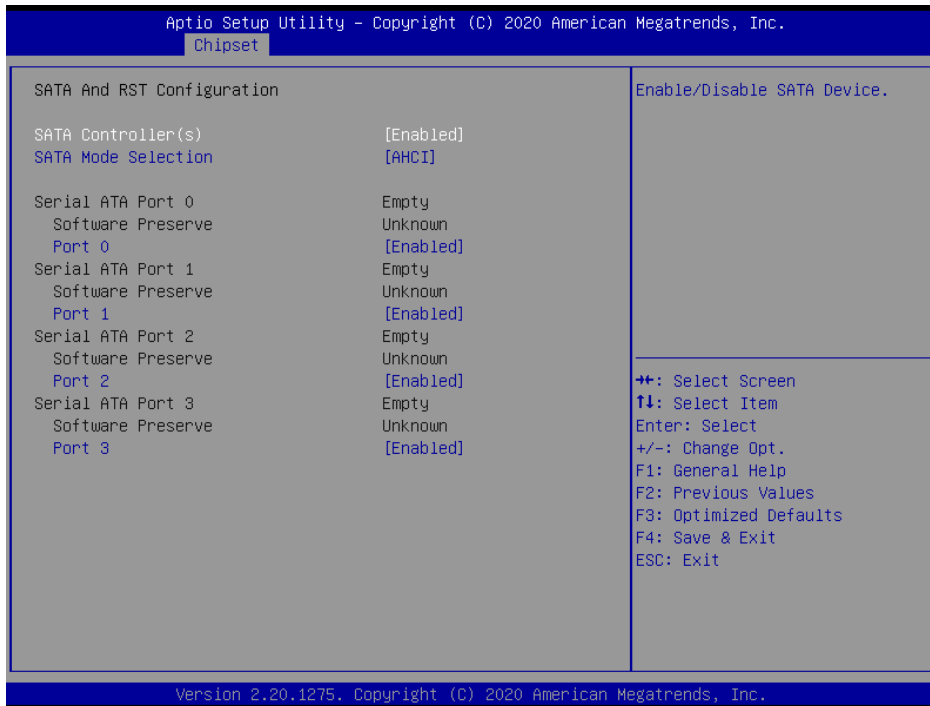

- **SATA Controller [Enabled]**  
 Enable or Disable SATA device  
 Configuration options: [Enabled][Disabled]
- **SATA Mode Selection [AHCI]**  
 Determines how SATA controller operate  
 Configuration options: [AHCI][Intel RST Premium with Intel Optane System Acceleration]
- **Port 0 [Enabled]**  
 Enable or Disable SATA Port  
 Configuration options: [Disabled][Enabled]
- **Port 1 [Enabled]**  
 Enable or Disable SATA Port  
 Configuration options: [Disabled][Enabled]
- **Port 2 [Enabled]**  
 Enable or Disable SATA Port  
 Configuration options: [Disabled][Enabled]
- **Port 3 [Enabled]**  
 Enable or Disable SATA Port  
 Configuration options: [Disabled][Enabled]

## BQ370-MH3 BIOS Step 5.2.3 USB configuration

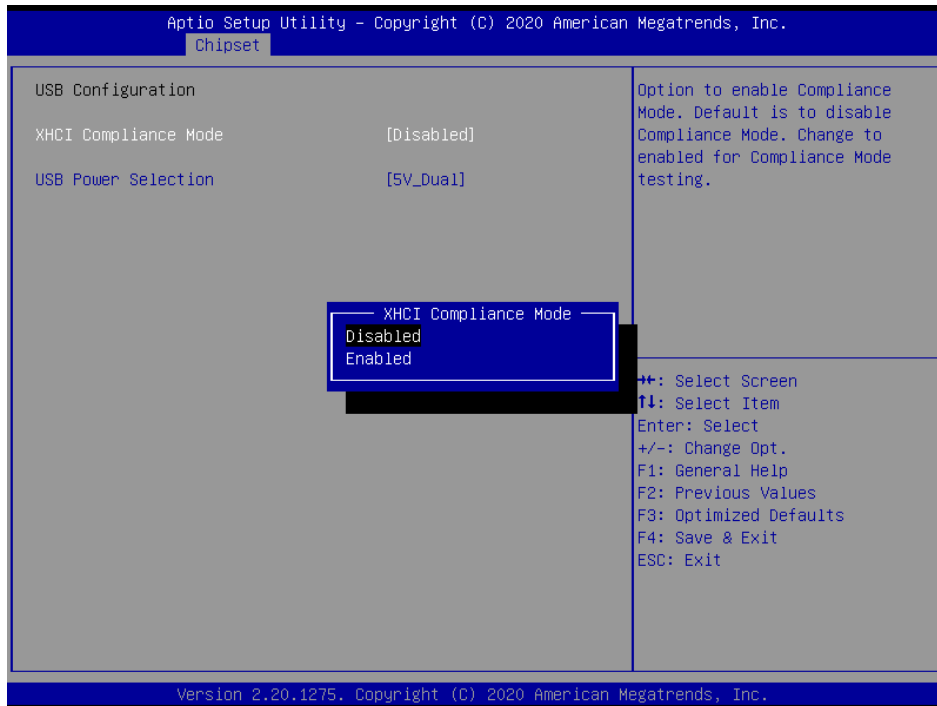

- **XHCI Compliance Mode [Disabled]**  
Options to enable Compliance Mode.  
Configuration options: [Disabled][Enabled]
- **USB Power Selection [5V\_Dual]**  
Select 5V\_Dual or 5V power for USB  
Configuration options: [5V][5V\_Dual]

## 5.2.4 HD Audio Configuration

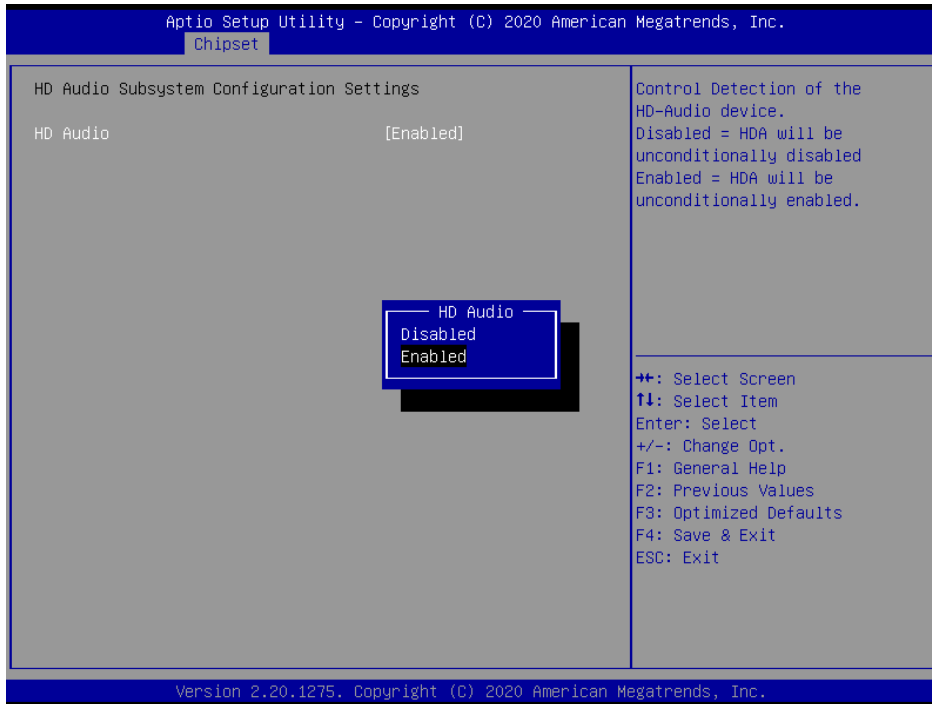

- **HD audio[Enabled]**  
Control Detection of the HD-Audio device.  
Configuration options: [Disabled][Enabled]

## BQ370-MH3 BIOS Step 5.2.5 Serial IO Configuration

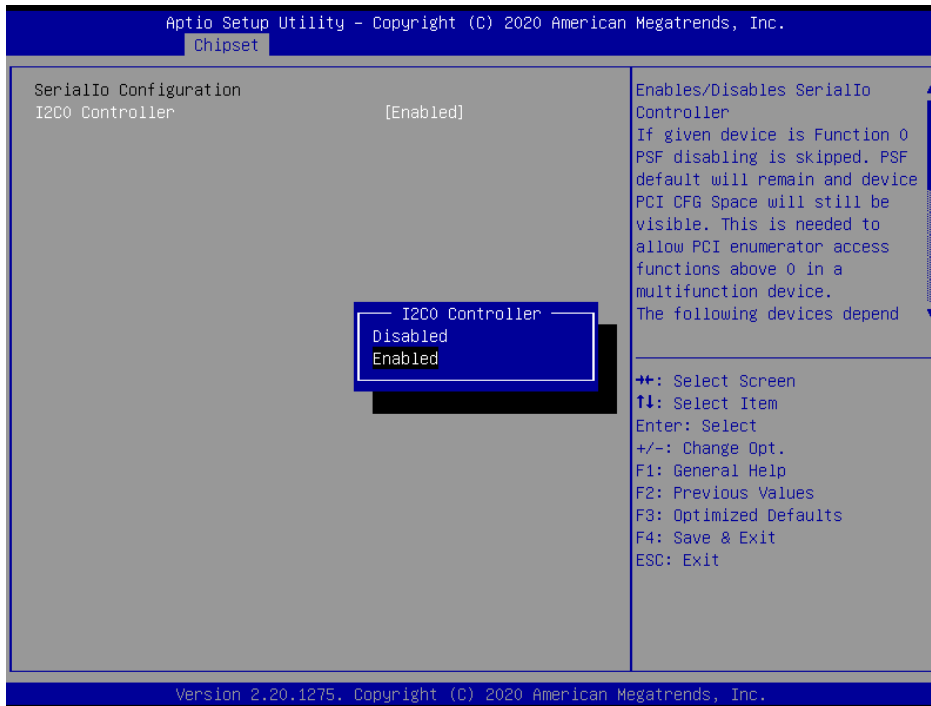

- **I2C0 [Enabled]**  
Enables/ Disables Serial IO Controller  
Configuration options: [Disabled][Enabled]

## 6 Security

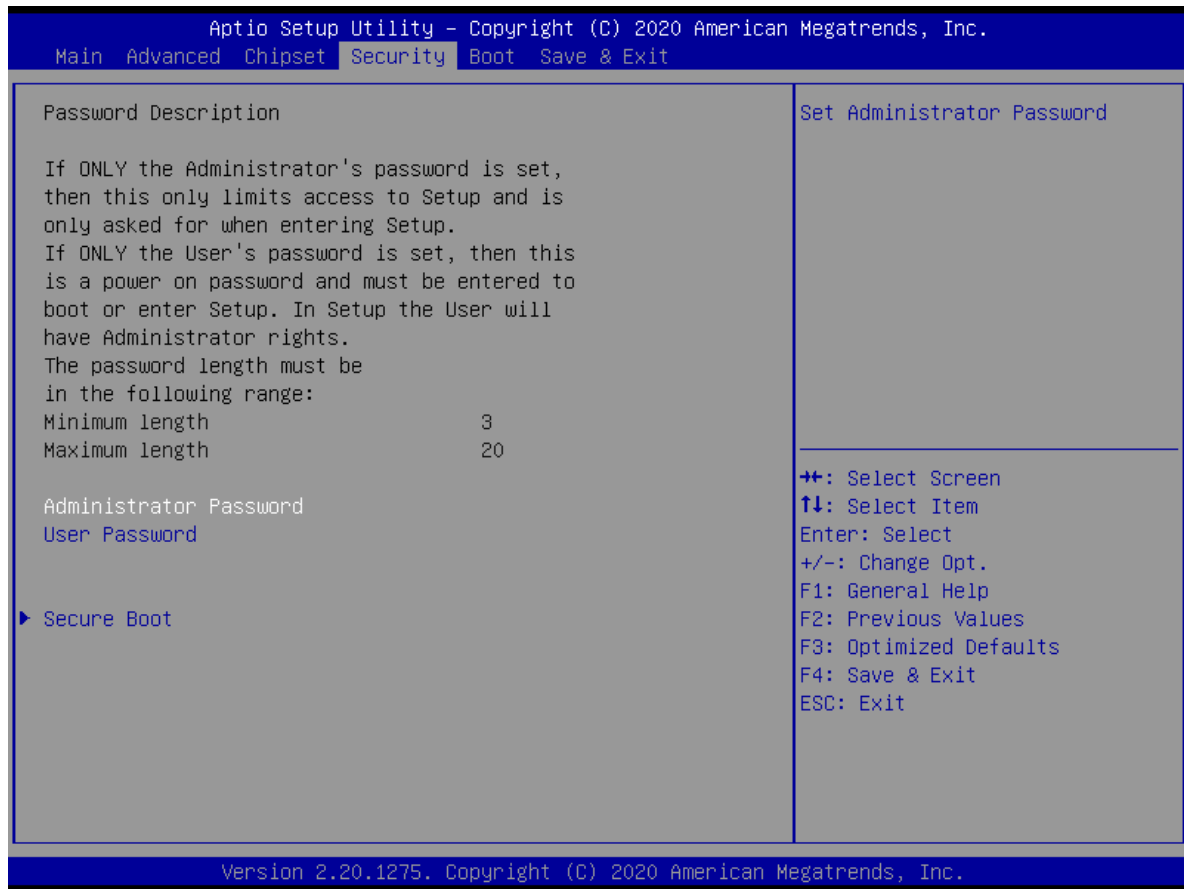

- **Administrator Password**  
Set setup Administrator Password
- **User Password**  
Set User Password

# BIOS - Overview and functions

## BQ370-MH3 BIOS Step 6.1 Secure boot

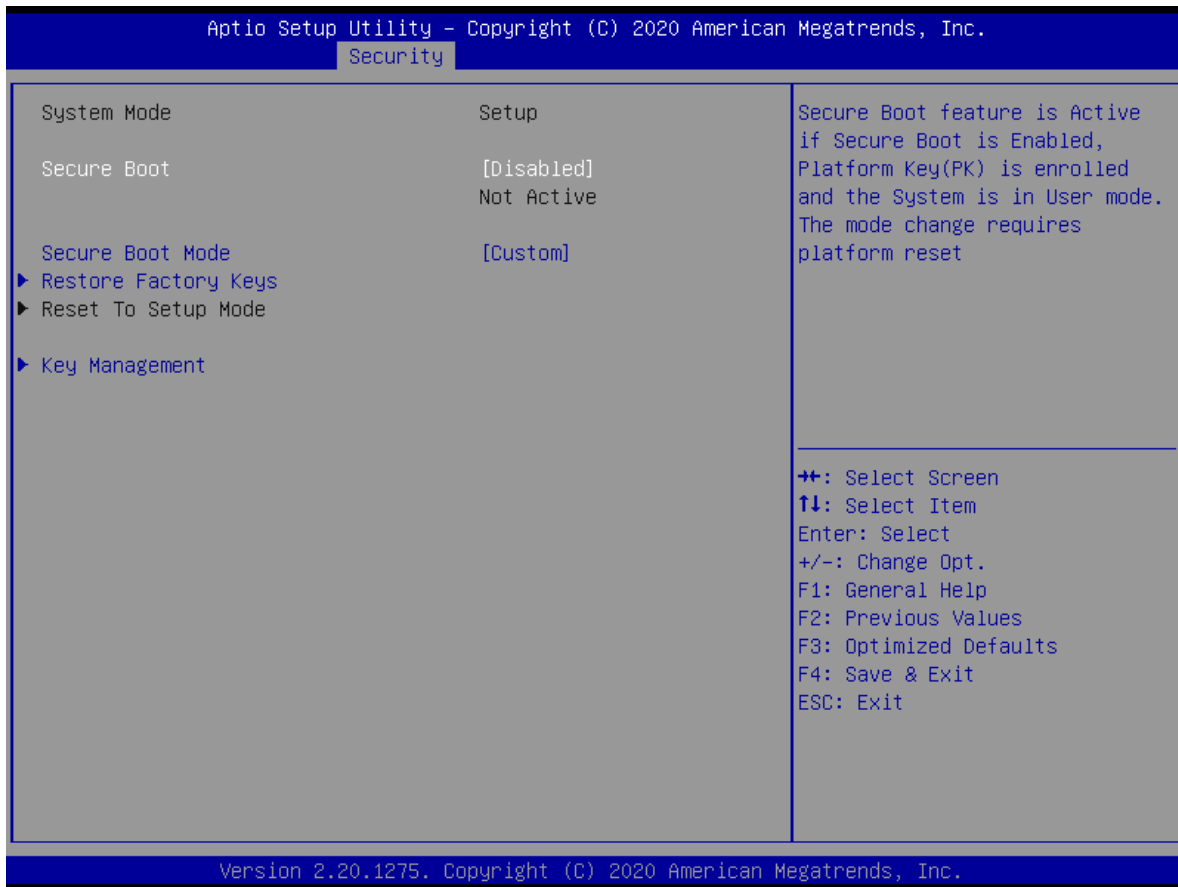

- **Secure Boot[Disabled]**  
Enable or Disable system secure boot.  
Configuration options: [Disabled] [Enabled]
- **Secure Boot mode[Custom]**  
Secure boot mode option  
Configuration options: [Standard][Custom]
- **Restore Factory keys**  
Force system to user mode. Install factory default secure boot key database.
- **Reset to Setup Mode**  
Secure boot mode option  
Configuration options: [Standard][Custom]

## 6.1.1 Key management

This sheet describe keys installation and status for secure boot. We suggest user do not change these default setting if you are not familiar with secure boot setting.

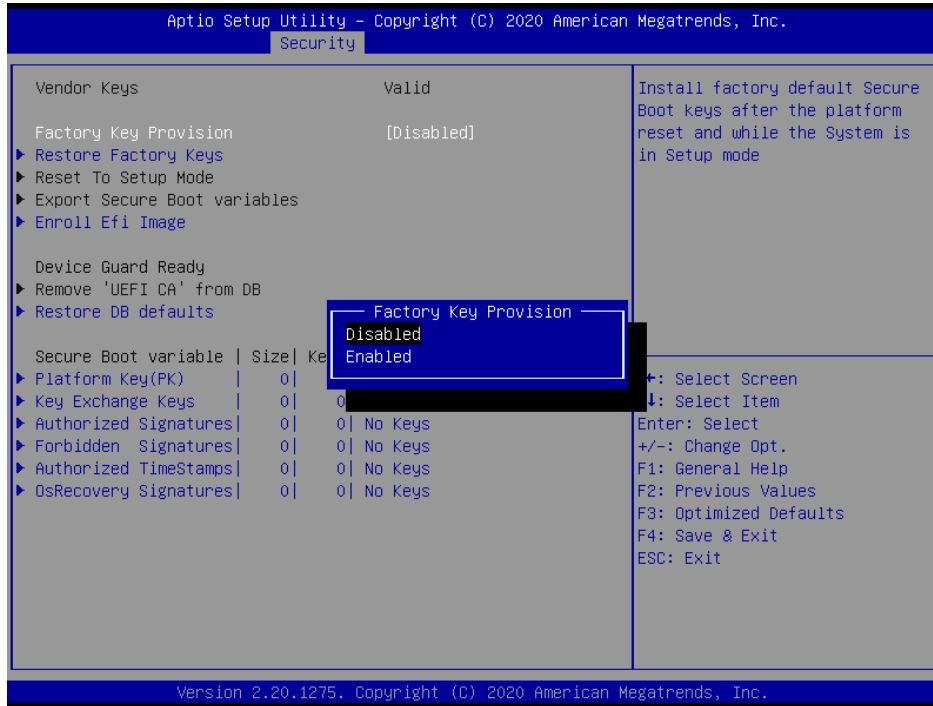



# BIOS - Overview and functions

## BQ370-MH3 BIOS Step

### 7 Boot

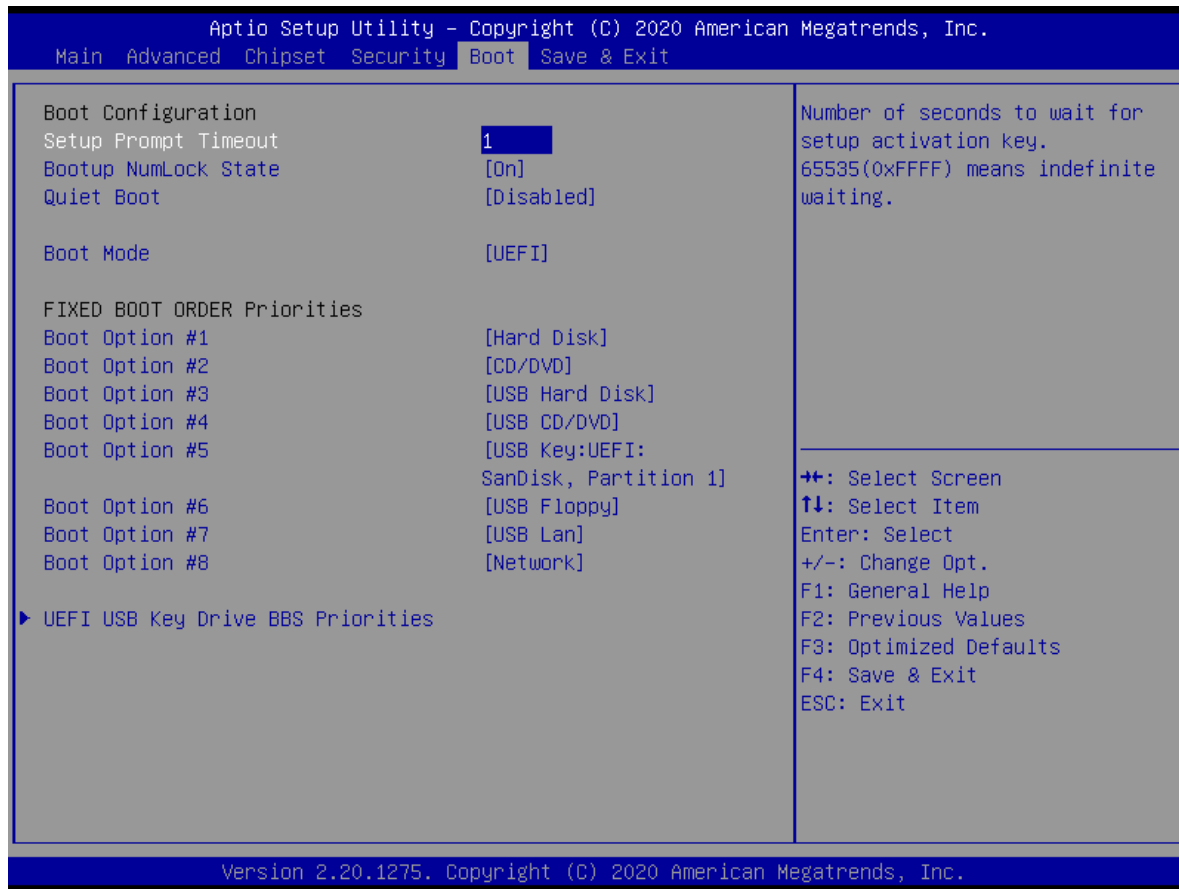

- **Setup Prompt Timeout [1]**  
Number of seconds to wait for setup activation key. 65535(0xFFFF) means indefinite waiting.
- **Bootup NumLock State [On]**  
Select the keyboard NumLock state  
Configuration options: [On][Off]
- **Quick Boot [Disable]**  
Enable or disable Quick Boot option  
Configuration options: [Disabled][Enabled]
- **Boot mode [UEFI]**  
Select boot mode LEGACY/UEFI  
Configuration options: [LEGACY][UEFI]
- **UEFI USB Key Drive BBS Priorities**  
Specifies the boot device priority sequence from available UEFI USB key Drives.

## 8 Save & Exit

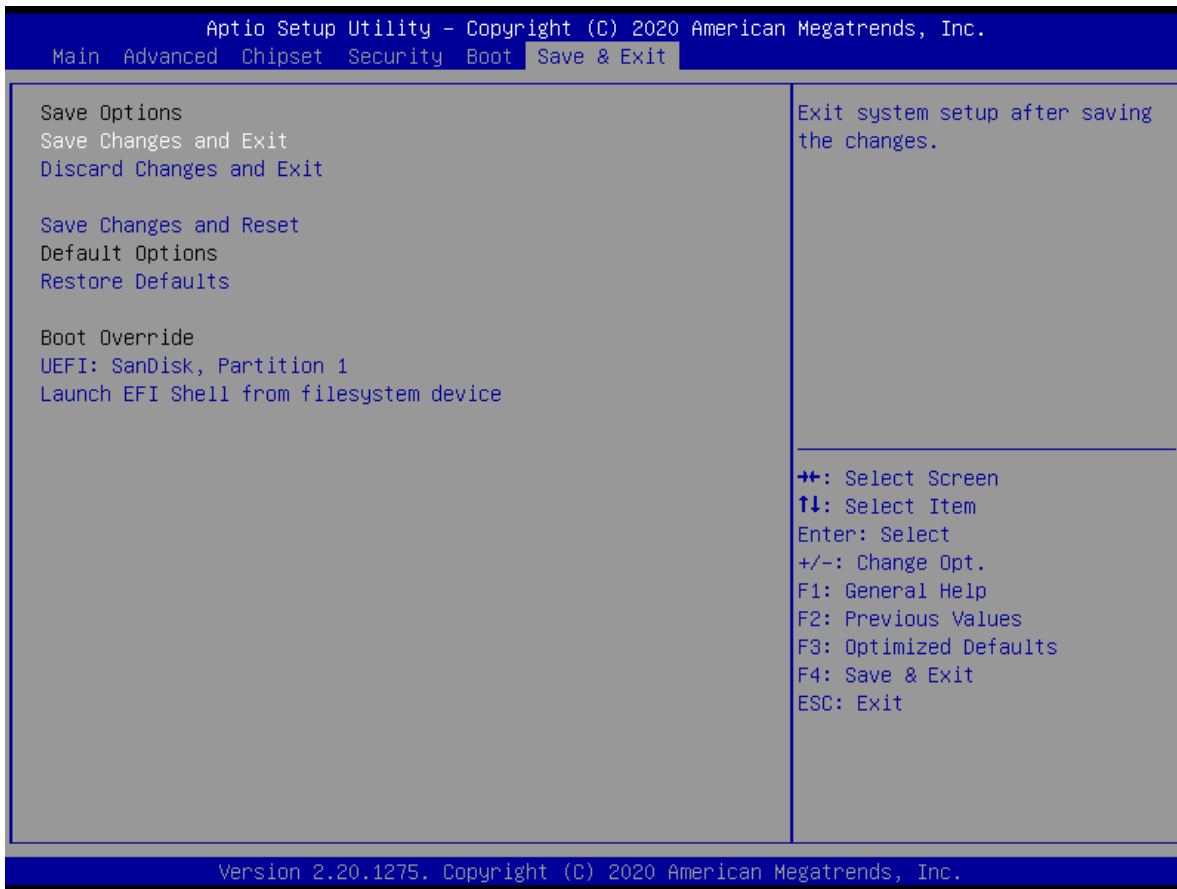

- **Save changes and Exit**  
Exit system setup after saving the changes.
- **Discard changes and Exit**  
Exit system setup without saving the changes.
- **Save changes and Reset**  
Reset the system after saving the changes.
- **Restore Defaults**  
Restore/Load default values for all the setup options.

# BIOS - How to create RAID volume

## Instructions

Before configuring it is assumed the user has the appropriate knowledge on how to enter and navigate within BIOS and change values. When BIOS screen has been accessed, follow the steps below.

## Enable RAID mode

1. Press Del key during boot (shortly after you hear the beep) to enter BIOS.
2. Go to "Chipset -> PCH-IO Configuration -> SATA and RST Configuration"
3. Set SATA mode selection to: "Intel RST Premium With Intel Optane System Acceleration"
4. Press F4 and select Yes to save configuration.
5. Reboot is needed before RAID volume settings are enabled and available in BIOS.

Steps to set up RAID volume differs depending on if boot mode is set to UEFI (default) or Legacy.

## Create RAID Volume, UEFI mode

1. After RAID has been set and unit rebooted, press Del key to enter BIOS.
2. Go to "Advanced -> Intel(R) Rapid Storage Technology".
  - a. This menu will only show after RAID is enabled and system rebooted.
3. Select Create RAID Volume
  - a. Enter volume name. Default: Volume1
  - b. Select RAID Level. Available options depend on how many drives are connected.
    - 2+ drives:
      1. RAID0 (Stripe)
        - a. Increased Read and Write performance.
        - b. No redundancy.
        - c. Not recommended for critical systems!
      2. RAID1 (Mirror)
        - a. Increased Read performance.
        - b. Good redundancy.
        - c. Recommended for most setups.
      3. Recovery
        - a. This is not RAID but a backup function to copy data from master disk to a recovery disk.
    - 3+ drives:
      1. RAID5 (Parity)
        - a. Increased Read and decreased Write performance.
        - b. Decent redundancy, only one drive can fail.
        - c. Not recommended for most setups. Should be avoided for large drives (1TB+) due to rebuild time and increased risk of failure.
    - 4 drives:
      1. RAID10 (Mirror + Stripe)
        - a. Very good read and write performance.
        - b. Good redundancy, up to two drives can fail.
        - c. Best solution for setups where both increased performance and redundancy is required.
  - c. Select disks to include in the new RAID volume
    - Press Enter and select X option for each disk.
    - If Recovery option is selected, M/R options will show instead.
      1. M should be set for Master Disk
      2. R should be set for Recovery Disk
  - b. Select Strip Size (RAID0 and RAID5 only).
    - Low strip size is preferred for System drives and database. High strip size is preferred for File

## BIOS - How to create RAID volume

Servers. If you are unsure we suggest to use default setting.

- Default is 16KB for RAID0 and 32KB for RAID5.

c. Set Capacity.

- Will be set to max available by default.

d. Set Synchronization (for Recovery option only).

- Continuous: Synchronize continuously when recovery volume is plugged in

- On Request: Synchronize only on request.

e. Select Create Volume to create the new RAID volume when everything is set.

- **Warning: All existing data on selected drives will be lost!**

f. Your RAID Volume is now ready for use.

- OS must be reinstalled or system image loaded.

- Note that Intel® RST RAID driver and software should be installed in OS for optimal RAID performance and functionality

### Create RAID Volume, Legacy mode

If boot mode is changed from UEFI (default and recommended for Win 10) to Legacy, the steps are slightly different. Instead of entering main bios menu after enabling RAID, press Ctrl+i during boot to enter RAID BIOS menu (Intel RST Option ROM).

After you have entered RAID BIOS, the steps to create RAID volume are the same as for step 3 in procedure for UEFI above.

### Available RAID levels:

- RAID 0 - Striping.

Requires 2+ drives.

Increased Read and Write performance.

No redundancy.

Not recommended for critical systems!

- RAID 1 - Mirroring.

Requires 2 drives.

Increased Read performance.

Good redundancy.

Recommended for most setups.

- RAID 5 - Block-level striping, with distributed parity.

Requires 3+ drives.

Increased Read and decreased Write performance.

Decent redundancy, only one drive can fail.

RAID5 is generally not recommended. It should be avoided for large drives (1TB+) due to slow rebuild time and increased risk of second drive failure.

- RAID 10 - Mirrored and striped. Not available (requires 4 drives, only max 3 drives possible on HT B30 models).

- Recovery - Backup data to recovery disk.

Requires 2 drives.

This is not RAID but a backup function to copy data from master disk to a recovery disk.

Master and Recovery disk needs to be set in Select Disks option.

Available synchronisation options:

Continuous - Updated automatically.

On Request - Updated manually.

## BIOS - Hybrid Multi Monitor Configuration

### Set up onboard signal output simultaneously with PCIe Graphics Card

PCIe cards with 4x additional DP or mDP outputs are available as factory mounted options where higher graphics performance or 4+ display outputs are needed.

Onboard graphics include two DP++ outputs and a USB-C output that can be used as a third DP signal by using a "USB-C to DP adapter".

When PCIe card is connected, the onboard outputs are disabled by default.

BIOS settings can be changed to enable the onboard outputs in addition to PCIe graphics card.

### To enable onboard display outputs, when PCIe graphics is present:

- 1: Press Del key during boot to enter BIOS menu.
- 2: From first BIOS menu navigate to "Chipset / System Agent (SA) Configuration" and press enter
- 3: Then navigate to "Graphics Configuration" and press enter
- 4: Select option "Internal Graphics", set to "Enabled" and press enter.
- 5: Press F4 and Enter to save setting and reboot. The Operating System (OS) will now detect the changes made and you will see all your available display outputs.

Note that driver update and reboot may be required in some cases if OS does not already include latest drivers for both onboard controller and PCIe card.

This is tested OK with Windows 10 OS. Linux OS have limited or no support for this feature.

# WatchDog Timer function

The following extracted section below are available in the full documentation at our website. Please visit: [https://www.hattelandtechnology.com/hubfs/pdf/misc/nct6106d\\_programming\\_guide\\_v071.pdf](https://www.hattelandtechnology.com/hubfs/pdf/misc/nct6106d_programming_guide_v071.pdf)

## 5. WATCH DOG TIMER

The Watchdog Timer of the NCT6102D / NCT6104D / NCT6106D consists of an 8-bit programmable time-out counter and a control and status register. GPIO0, GPIO2, GPIO3, GPIO5, GPIO6, GPIO7 provides an alternative WDT1 function. This function can be configured by the relative GPIO control register. The units of Watchdog Timer counter can be selected at Logical Device 8, CR[F0h], bit[3]. The time-out value is set at Logical Device 8, CR[F1h], default is 4. Writing zero disables the Watchdog Timer function. Writing any non-zero value to this register causes the counter to load this value into the Watchdog Timer counter and start counting down.

When Watchdog Timer 1 time-out event is occurring, GPIO0 bit[1], [5], GPIO2, bit[3], [7], GPIO3 bit[1], [5], GPIO5 bit[0], [4], GPIO6 bit[7], GPIO7 bit[0], will trigger a low pulse approx 100mS. Also the event could go to pin77 WDT0#. In other words, when the value is counted down to zero, the timer stops, and the NCT6102D / NCT6104D / NCT6106D sets the WDT1 status bit in Logical Device 8, CR[F2h], bit[4]. Writing a zero will clear the status bit. It. This bit will also be cleared if LRESET# or PWROK# signal is asserted.

The Watchdog Timer 2 of the NCT6102D / NCT6104D / NCT6106D consists of an 8-bit programmable time-out counter register (Logic Device D, CR[E2h]) and status register (Logic Device D, CR[E4h] bit7). The timeout event will trigger PWROK pin to generate a low pulse when Logic Device D, CRE3[bit0] is timer count down start bit. When Logic Device D, CRE3[bit0] set to one, the timer will start count down, until this bit is written to zero.

Watchdog Timer I related registers are listed below.

Watchdog Timer I has four registers in Logic Device 8. When CR30h bit0=1, Watchdog Timer circuit is activated, then CRF5, F6, and F7h are meaningful. Watchdog Timer reset source selection is located at Logic Device A, CRE7h, bit3.

Logical Device Number	Register address	Register Description
Logical Device 8	CR30h, bit0	Watchdog Timer I circuit enable / disable
Logical Device 8	CRF0h	Watchdog Timer I Control Mode Register
Logical Device 8	CRF1h	Watchdog Timer I Counter Register
Logical Device 8	CRF2h	Watchdog Timer I Control & Status Register
Logical Device A	CRE7h, bit3	Watchdog Timer I reset source is LRESET# or PWROK

### 5.1 Enable Timer

- (1) CR30h bit0 = 1, enable Watchdog Timer I circuit.
- (2) Configure CRF0h for time unit or other options.
- (3) Set time limit into CRF1h then hardware will auto count down. New time limit value overwriting is acceptable. When CRF1h counts down to 0x0, hardware outputs timeout event on both flag (CRF2h bit4) and pin (via GPIO).
- (4) Check then clear CRF2h bit4 (watchdog timeout flag), the timer will restart counting and de-assert pin (via GPIO).

### 5.2 Disable Timer

- (1) Set 0x0 to CRF1h, stop Watchdog Timer I counting.
- (2) CR30h bit0 = 0, disable Watchdog Timer I circuit if no longer use.

### 5.3 Application Note

- (1) When Watchdog Timer I is counting, if want to terminate, BIOS or program MUST stop timer (set 0x0 to CRF1h) first then call platform reset.
- (2) Watchdog Timer I function is reset by LRESET# or PWROK. Cold reset (front panel reset button), warm reset (CTRL-ALT-DEL), or any application that drives LRESET# event, Watchdog Timer I would be reset.
- (3) When Watchdog timeout, the WDT0 pin (via GPIO) keeps asserting until flag (CRF2h bit4) is cleared to 0.

## WatchDog Timer function

The following extracted section below are available in the full documentation at our website. Please visit:  
[https://www.hattelandtechnology.com/hubfs/pdf/misc/nct6106d\\_nct6104d\\_nct6102d\\_application\\_note\\_v3\\_6.pdf](https://www.hattelandtechnology.com/hubfs/pdf/misc/nct6106d_nct6104d_nct6102d_application_note_v3_6.pdf)

### 12. Watch Dog Timer accuracy

When the Watch Dog Timer setting is less than 15 sec, it is suggested that BIOS compensate 1~2 sec for more accuracy. For example, if the target Watch Dog Timer is 10 sec, BIOS needs to set it as 8 sec to compensate for the accuracy.

To avoid the unexpected watchdog event, please refer to below items for watchdog timer stop:

- a. When watchdog timer counter is set, the watchdog could only be stopped after a period of time. This period will be 4 seconds (LDN[8] CR[F5] Bit4=0) or 4 minutes (LDN[8] CR[F5] Bit4=1). If stopping the counter in the period, it will trigger the watchdog timer directly.
- b. To stop the watchdog timer, please set the timer counter register to 00h first, then clear watch-dog status register.

# Pinout Assignments

Connectors illustrated here are either standard by factory default or may be available (through factory customization). Note that some combinations may not be possible due to space restrictions. List also valid for customized models. All pin out assignments are seen from users Point of View (POV) while looking straight at the connector. Please review the dedicated datasheet or technical drawings for your actual unit to identify and determine the presence of desired connector. Detailed information about Housing Connectors (terminal blocks) can be found earlier in this manual.

## 9-pin USB3.0/3.1/3.2 TYPE A

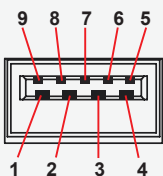

PIN 01	VCC +5V	VBUS / Power
PIN 02	D-	Negative Data
PIN 03	D+	Positive Data
PIN 04	GND	Ground
PIN 05	StdA_SSRX-	SuperSpeed Receive Negative Data
PIN 06	StdA_SSRX+	SuperSpeed Receive Positive Data
PIN 07	GND DRAIN	Ground for signal return
PIN 08	StdA_SSTX-	SuperSpeed Transmit Negative Data
PIN 09	StdA_SSTX+	SuperSpeed Transmit Positive Data

## 24-pin USB-C TYPE A

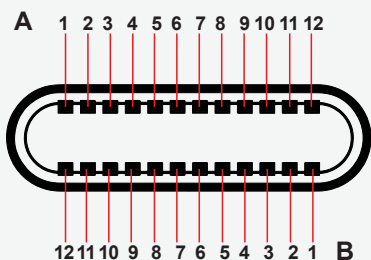

Pin A1	GND	Ground return
Pin A2	SSTXp1	SuperSpeed differential pair #1, TX, positive
Pin A3	SSTXn1	SuperSpeed differential pair #1, TX, negative
Pin A4	VBUS	Bus power
Pin A5	CC1	Configuration channel
Pin A6	Dp1	USB 2.0 differential pair, position 1, positive
Pin A7	Dn1	USB 2.0 differential pair, position 1, negative
Pin A8	SBU1	Sideband use (SBU)
Pin A9	VBUS	Bus power
Pin A10	SSRXn2	SuperSpeed differential pair #4, RX, negative
Pin A11	SSRXp2	SuperSpeed differential pair #4, RX, positive
Pin A12	GND	Ground return
Pin B12	GND	Ground return
Pin B11	SSRXp1	SuperSpeed differential pair #2, RX, positive
Pin B10	SSRXn1	SuperSpeed differential pair #2, RX, negative
Pin B9	VBUS	Bus power
Pin B8	SBU2	Sideband use (SBU)
Pin B7	Dn2	USB 2.0 differential pair, position 2, negative
Pin B6	Dp2	USB 2.0 differential pair, position 2, positive
Pin B5	CC2	Configuration channel
Pin B4	VBUS	Bus power
Pin B3	SSTXn2	SuperSpeed differential pair #3, TX, negative
Pin B2	SSTXp2	SuperSpeed differential pair #3, TX, positive
Pin B1	GND	Ground return

## Serial COM RS-485/RS-422, 9-pin DSUB Male "Full Duplex Mode"

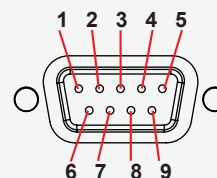

PIN 01	TxD-	Transmit Data Negative
PIN 02	TxD+	Transmit Data Positive
PIN 03	RxD+	Receive Data Positive
PIN 04	RxD-	Receive Data Negative
PIN 05	GND	Signal Ground
PIN 06	N/C	No internal connection
PIN 07	N/C	No internal connection
PIN 08	N/C	No internal connection
PIN 09	N/C	No internal connection

\*Master only. ECHO not supported.

Note: Configuration performed in computer BIOS

## Serial COM RS-485/RS-422, 9-pin DSUB Male "Half Duplex Mode"

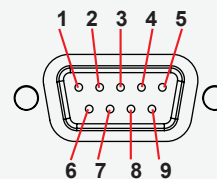

PIN 01	Data-	Data Negative
PIN 02	Data+	Data Positive
PIN 03	N/C	No internal connection
PIN 04	N/C	No internal connection
PIN 05	GND	Signal Ground
PIN 06	N/C	No internal connection
PIN 07	N/C	No internal connection
PIN 08	N/C	No internal connection
PIN 09	N/C	No internal connection

\*ECHO not supported.

Flow control: Via RTS signal (controlled by user application).

Note: Configuration performed in computer BIOS



# Pinout Assignments

## 20-pin DisplayPort (DP) Female

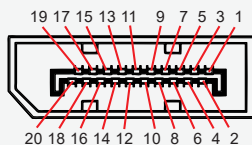

PIN 01	ML Lane 0 (p) - Lane 0 (positive)
PIN 02	GND - Ground
PIN 03	ML Lane 0 (n) - Lane 0 (negative)
PIN 04	ML Lane 1 (p) - Lane 1 (positive)
PIN 05	GND - Ground
PIN 06	ML Lane 1 (n) - Lane 1 (negative)
PIN 07	ML Lane 2 (p) - Lane 2 (positive)
PIN 08	GND - Ground
PIN 09	ML Lane 2 (n) - Lane 2 (negative)
PIN 10	ML Lane 3 (p) - Lane 3 (positive)
PIN 11	GND - Ground
PIN 12	ML Lane 3 (n) - Lane 3 (negative)
PIN 13*	CONFIG1 - connected to Ground*
PIN 14*	CONFIG2 - connected to Ground*
PIN 15	AUX CH (p) - Auxiliary Channel (positive)
PIN 16	GND - Ground
PIN 17	AUX CH (n) - Auxiliary Channel (negative)
PIN 18	Hot Plug - Hot Plug Detect
PIN 19	Return - Return for Power
PIN 20	DP PWR - Power for connector (3.3 V 500 mA)

\*Pins 13 and 14 may either be directly connected to ground or connected to ground through a pull-down device. This is the pinout for source-side connector, the sink-side connector pinout will have lanes 0-3 reversed in order; i.e., lane 3 will be on pin 1(n) and 3(p) while lane 0 will be on pin 10(n) and 12(p).

## 8-pin RJ45 10/100/1000Mbps LAN/Ethernet

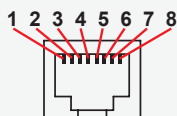

PIN 01	D0P+	Differential Pair 0 (Positive)
PIN 02	D0N-	Differential Pair 0 (Negative)
PIN 03	D1P+	Differential Pair 1 (Positive)
PIN 04	D2P+	Differential Pair 2 (Positive)
PIN 05	D2N-	Differential Pair 2 (Negative)
PIN 06	D1N-	Differential Pair 1 (Negative)
PIN 07	D3P+	Differential Pair 3 (Positive)
PIN 08	D3N-	Differential Pair 3 (Negative)

## Serial COM RS-232 non-isolated, 9-pin DSUB Male

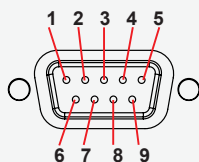

PIN 01	DCD	Data Carrier Detect
PIN 02	RxD	Receive Data
PIN 03	TxD	Transmit Data
PIN 04	DTR	Data Terminal Ready
PIN 05	GND	Signal Ground
PIN 06	DSR	Data Set Ready
PIN 07	RTS	Request To Send
PIN 08	CTS	Clear To Send
PIN 09	RI	Ring Indicator

## 9-pin Amplified Mono/Stereo Audio Out, DSUB Female

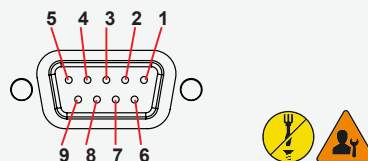

PIN 01	LAUDR	Left Audio Return*
PIN 02	LAUD	Left Audio*
PIN 03	RAUDR	Right Audio Return
PIN 04	RAUD	Right Audio
PIN 05	N/C	No internal connection
PIN 06	N/C	No internal connection
PIN 07	N/C	No internal connection
PIN 08	N/C	No internal connection
PIN 09	N/C	No internal connection

\*For Mono: connect pin 01 and 02 only

## 10+10 pin Isolated Digital Input/Output Module

Type Number "PCA100297-1"

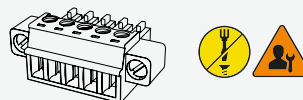
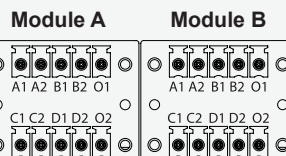

### Module A

A1	External Power +	A1	IN+[0]
A2	N/C (Not Connected)	A2	IN-[0]
B1	External Power - (GND1)	B1	IN+[1]
B2	N/C (Not Connected)	B2	IN-[1]
O1	HS[0]	O1	N/C
C1	HS[1]	C1	IN+[2]
C2	N/C (Not Connected)	C2	IN-[2]
D1	HS[2]	D1	IN+[3]
D2	N/C (Not Connected)	D2	IN-[3]
O2	HS[3]	O2	N/C

## COM Module RS-232 - 2 x ports, 9-pin DSUB Male

Type Number "PCA100309-1"

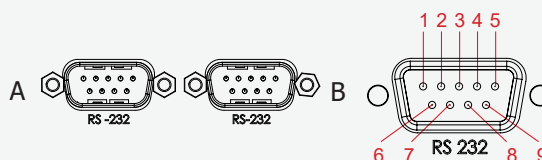

PIN 01	DCD	Data Carrier Detect
PIN 02	RxD	Receive Data
PIN 03	TxD	Transmit Data
PIN 04	DTR	Data Terminal Ready
PIN 05	GND	Signal Ground
PIN 06	DSR	Data Set Ready
PIN 07	RTS	Request To Send
PIN 08	CTS	Clear To Send
PIN 09	RI	Ring Indicator

# Pinout Assignments

## 4+4 pin CAN I/O Module, 2 channels

Type Number "ZIA0001310-B / ZIA0001310-SLCAN"

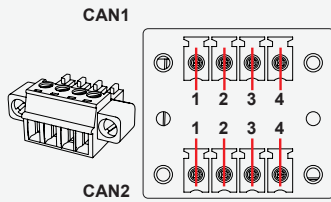

Pin 01	Can1	CAN L
Pin 02	Can1	CAN L
Pin 03	Can1	CAN H
Pin 04	Can1	CAN H

Pin 01	Can2	CAN L
Pin 02	Can2	CAN L
Pin 03	Can2	CAN H
Pin 04	Can2	CAN H

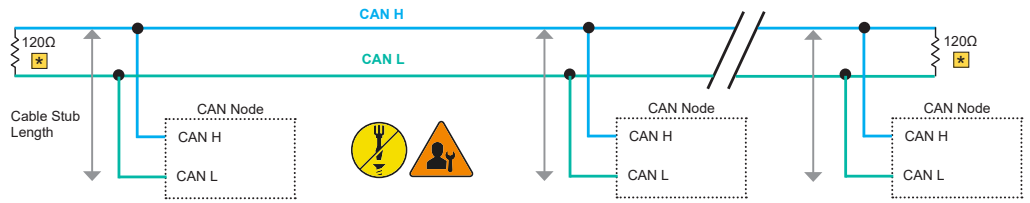

\* Note: 110/120Ω termination is decided by impedance of cable.

## 10+10 pin RS-422 / RS-485 NMEA Module

Type Number "PCA200828-1 / PCA100293-1"

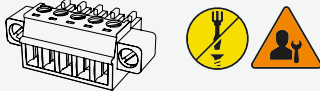
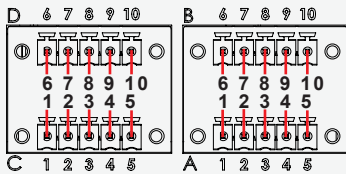

PIN 01	TxD-	Transmit Data Negative
PIN 02	TxD+	Transmit Data Positive
PIN 03	GND	Isolated Ground
PIN 04	RxD-	Receive Data Negative
PIN 05	RxD+	Receive Data Positive
PIN 06	TxD-	Transmit Data Negative
PIN 07	TxD+	Transmit Data Positive
PIN 08	GND	Isolated Ground
PIN 09	RxD-	Receive Data Negative
PIN 10	RxD+	Receive Data Positive

RS-485 Half Duplex (2-wire) Configuration:  
Connect TX and RX pair-wise:  
TX- to RX-, TX+ to RX+.

\*Note: The jumper for "force of transmitter (Forced TX(y))" is open by factory default. For some custom models this jumper is preset to closed (active), in that case unit has to be opened and jumper set to open to allow Half Duplex mode.

Only applicable for Multi-Power (AC+DC) models

## 2-pin Terminal Block 5.08 - DC Power Input

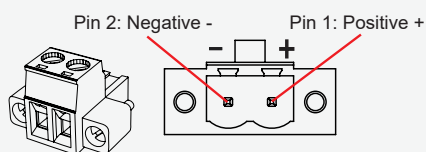

## Operating System Recovery (tool)

### Reference: DOC207939-1

The tool described in this chapter is available directly from Support at Hatteland Technology. In order to receive a copy of the software (Windows 10 only) and the appropriate matching OS image to your exact product model, please have a complete unit's Type number and Serial number ready prior to contacting Support at Hatteland Technology (or through dedicated Service Partner channels) via: <https://www.hattelandtechnology.com/support/contact>

### Please note:

- At least 30GB of free disk space is needed on the unit in order to create the 16GB USB Memory Stick.
- It can take up to 1 hour to create the USB Memory Stick.

## 1 How to Use

### 1.1 Prerequisites

To create the Recovery USB-stick, you need to have the following:

- A Windows 10 PC, with Windows version 1703 or newer.
- USB Drive. We recommend a size of at least 16GB.
- Customer Pack is provided by Hatteland Technology.

**Note:** This tool can only be used on Hatteland Technology products.

### 1.2 How to create your Recovery USB-Stick

1. Unpack the customer pack to your PC.
2. Run USB\_Setup.exe

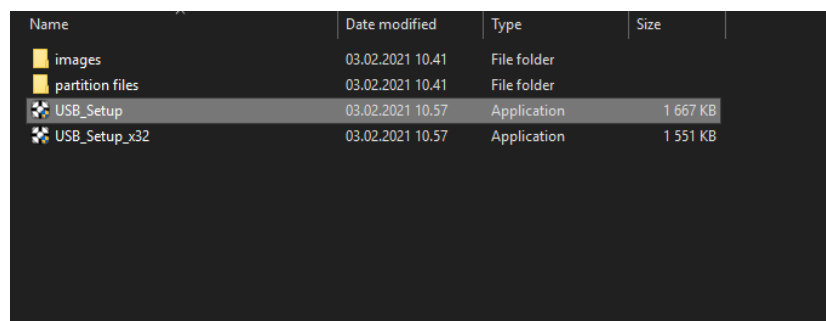

Name	Date modified	Type	Size
images	03.02.2021 10.41	File folder	
partition files	03.02.2021 10.41	File folder	
USB_Setup	03.02.2021 10.57	Application	1 667 KB
USB_Setup_x32	03.02.2021 10.57	Application	1 551 KB

3. Select your USB Drive in the dropdown menu.



## Trouble-shooting

You will be prompted to confirm that the selected USB will be completely wiped of all data. The USB-stick chosen will have all its data deleted.

4. The program will run for a couple of minutes, the speed of the creator depends on the speed of the operating system and the USB-stick.

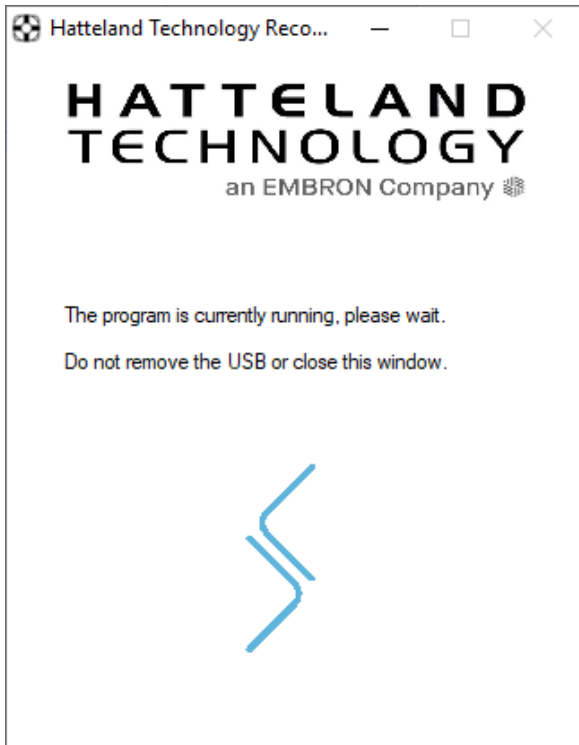

5. Wait for the "Success" message to appear and a dialog box will appear. Press OK.
6. You have now completed creating the USB Recovery Stick. Please disconnect the USB from the PC using the "Safe Removal" feature.

a.

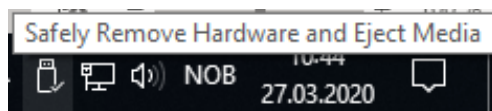

b.

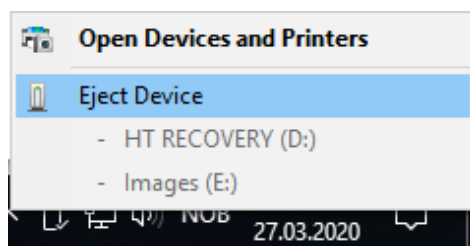

## 1.3 Using the USB Recovery Solution

### 1.3.1 Prerequisites

- This solution only works on Hatteland Technology Panel Computers and Hatteland Technology Computers.
- This solution does not support "Legacy" BIOS, only UEFI is supported.

### 1.3.2 How-to-use

Boot into your USB-stick, by pressing "F7"-key during start-up of your Hatteland Technology Panel Computer. Some of our computer models uses "F11"-key to access boot menu. You will see a list of bootable devices, select your USB-stick. If your USB-stick is shown with multiple partitions, select partition 1.

#### 1.3.2.1 Home Screen

From the home screen, you are met with a Recovery button and a Power button. You can click on them using mouse, touch or navigate with your keyboard ("Tab"-key).



# Trouble-shooting

## 1.3.2.2 Recovery

The Recovery buttons opens the recovery function.

You select the target drive you wish to recover.

The description in the large box is the description of the image.

When you press "ok", you will get a final warning that the target drive will be wiped and all data on the drive will be lost.

After pressing "yes", the program will do everything needed for the recovery automatically.

When finished, you are asked to restart or shut down your computer.

Please disconnect your USB-stick after restarting or shutting down.

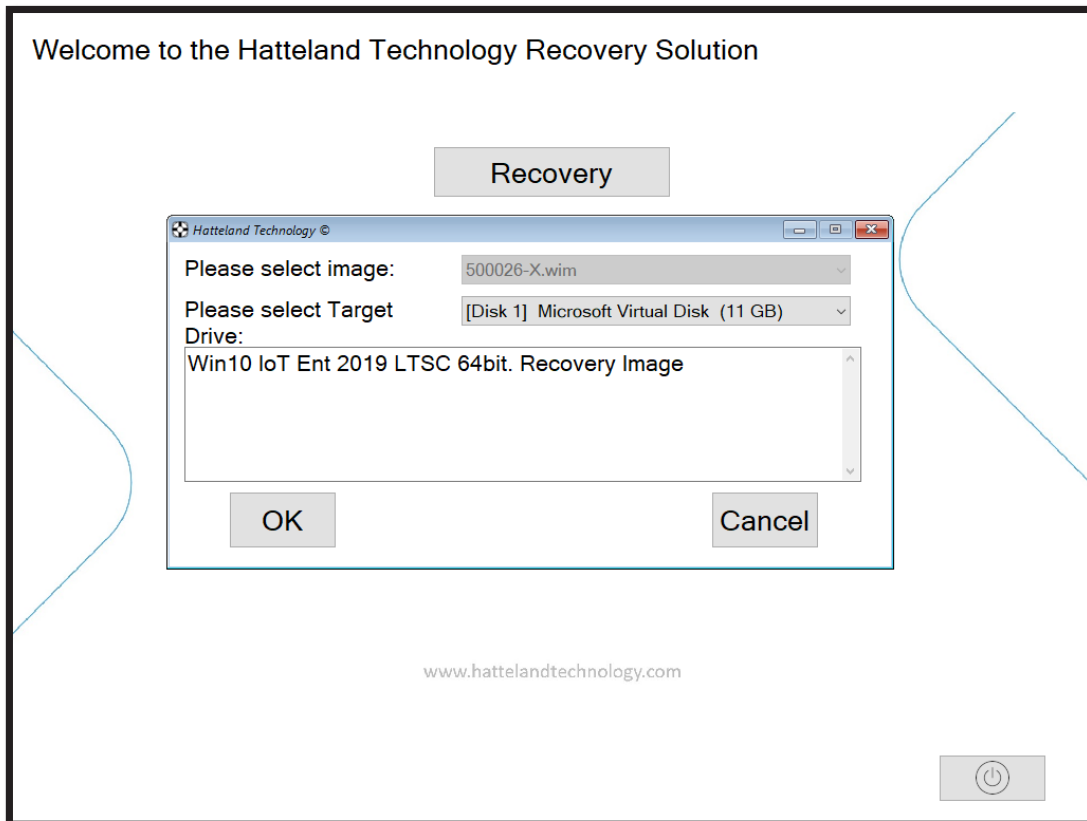

## Revision History

Rev	Created		Approved		Description
	Date	By	Date	By	
1	2020.07.16	Yrjan Rein	2020.07.22	Gunnar Myklebust	Initial Version
2	2021.02.03	Yrjan Rein	2021.02.04	Morten Mæland	Updated Pictures. Removed chapter that is not relevant to the function of "recovery only". Updated name of the USB setup executable.
3					

# Trouble-shooting

## How to activate Windows Recovery Environment on OS Drive

### Reference: DOC208258-1

Products delivered before Q1-2021 from Hatteland Technology may not have Windows Recovery Environment present. The Windows Recovery Environment must be manually activated before it can be used. Please follow the steps below.

1. Check if your device has WinRE activated.
  - a. Open Command Line window with Administrator rights
  - b. Run the command: `reagentc /info`

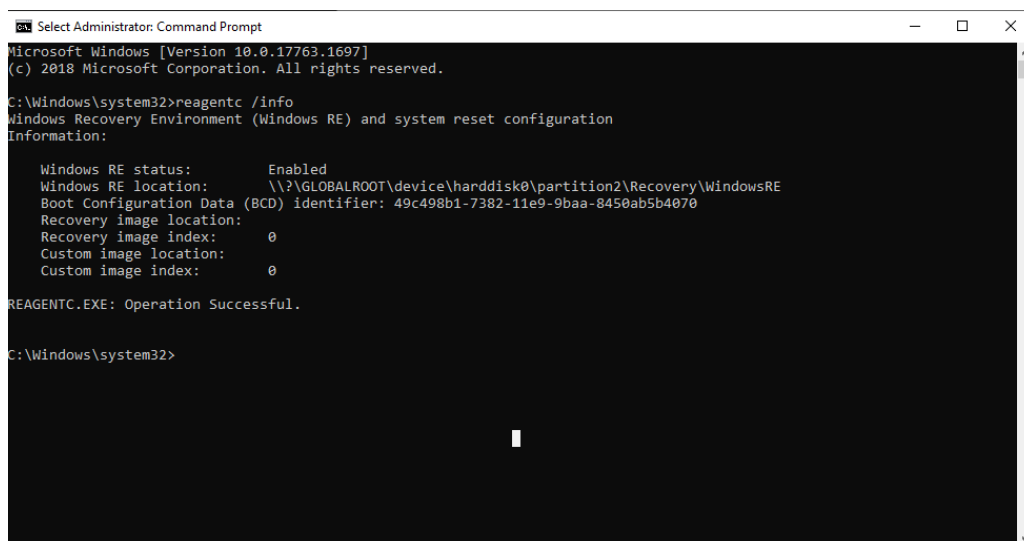

```
Select Administrator: Command Prompt
Microsoft Windows [Version 10.0.17763.1697]
(c) 2018 Microsoft Corporation. All rights reserved.

C:\Windows\system32>reagentc /info
Windows Recovery Environment (Windows RE) and system reset configuration
Information:

Windows RE status:           Enabled
Windows RE location:         \\?\GLOBALROOT\device\harddisk0\partition2\Recovery\WindowsRE
Boot Configuration Data (BCD) identifier: 49c498b1-7382-11e9-9baa-8450ab5b4070
Recovery image location:
Recovery image index:        0
Custom image location:
Custom image index:          0

REAGENTC.EXE: Operation Successful.

C:\Windows\system32>
```

- c. If it looks like the picture above, test the WinRE by typing the following command and restarting your computer: `reagentc /bootore`
    - d. If your computer successfully booted into Windows Recovery Environment, press "continue". You should boot into Windows like normal and the WinRE is verified.
  2. If your Windows RE status is "Disabled" or did not boot into Windows Recovery Environment during boot test, do the following steps:
    - a. Open Command Line window with administrator rights
    - b. Run the following commands in order:
      - i. `attrib -h -s c:\Recovery\WindowsRE\Winre.wim`
      - ii. `xcopy /h c:\Recovery\WindowsRE\Winre.wim c:\Windows\System32\Recovery`
      - iii. `reagentc /enable`
    - c. Now test the WinRE by restarting your PC after typing the command: `reagentc /bootore`
    - d. If your computer successfully booted into Windows Recovery Environment, press "continue". You should boot into Windows like normal and the WinRE is verified.
  3. If you're still unable to boot into WinRE or the status is still "disabled". Please contact Hatteland Technology Customer Support. Contact information available at <http://www.hattelandtechnology.com/>.

## Revision History

Rev	Created		Approved		Description
	Date	By	Date	By	
1	27.01.2021	Yrjan Rein	28.01.2021	Gunnar Myklebust	Initial Version
2					
3					



# IEC62368 policy for Hatteland Technology products

## Introduction

According to the requirements of EN 62368-1:2014.





The tables below refers to the policies for opening, servicing and installation of the unit(s) referred to in this manual. This equipment is designed to be used as a fixed installation and to be sold through special sales channels for professional use.

## Based on requirements EN 62368-1:2014 and IEC 62368-1:2018

Defenition	Description
<b>Ordinary person/ Sailor/End-User</b> 	Ordinary person is the term applied to all persons other than instructed persons and skilled persons. Ordinary persons include not only users of the equipment, but also all persons who may have access to the equipment or who may be in the vicinity of the equipment. Under normal operating conditions or abnormal operating conditions, ordinary persons should not be exposed to parts comprising energy sources capable of causing pain or injury. Under a single fault condition, ordinary persons should not be exposed to parts comprising energy sources capable of causing injury.
<b>Instructed person</b> 	Instructed person is a term applied to persons who have been instructed and trained by a skilled person, or who are supervised by a skilled person, to identify energy sources that may cause pain and to take precautions to avoid unintentional contact with or exposure to those energy sources. Under normal operating conditions, abnormal operating conditions or single fault conditions, instructed persons should not be exposed to parts comprising energy sources capable of causing injury.
<b>Skilled person</b> 	Skilled person is a term applied to persons who have training or experience in the equipment technology, particularly in knowing the various energies and energy magnitudes used in the equipment. Skilled persons are expected to use their training and experience to recognize energy sources capable of causing pain or injury and to take action for protection from injury from those energies. Skilled persons should also be protected against unintentional contact or exposure to energy sources capable of causing injury.



# IEC62368 policy for Hatteland Technology products

Authority	Description
<b>Children</b> 	This equipment is not suitable for use in locations where children are likely to be present.
<b>Ordinary person/ Sailor/End-User</b> 	Not allowed to open unit. Not allowed to install the unit. Not allowed to terminate/connect cables to the unit.
<b>Instructed person</b> 	Allowed to open hatches/latches which does not require tools, such as Disktrays. Allowed to open "battery-hatch" to change the battery even if tools are required. Allowed to install the unit. Allowed to terminate/connect cables to the unit indoors.
<b>Skilled person</b> 	Allowed to open and disassemble the unit.  Allowed to install the unit. Allowed to terminate/connect cables to the unit indoors and outdoors. Allowed to terminate/connect earth/ground wire.  Note: Be aware that additional definition for "skilled person" may apply, country dependent.

Conditions	Description
<b>AC power net Class</b>	Class 1. Pollution degree 2. Over voltage category 2.
<b>Transient requirement</b>	External circuits are considered to be installed wholly within the same building structure.
<b>Battery</b>	Obligated to use battery specified for the product.
<b>Altitude</b>	Products are designed for a max operating altitude of 2000m.

Installation	Description
<b>Mounting brackets</b>	Only bracket defined/specified for the unit is allowed.
<b>AC power cord</b>	When installed it shall be possible to disconnect the unit from the AC power net i.e. possible to reach AC connector.
<b>Transient requirement</b>	External circuits are considered to be installed wholly within the same building structure.
<b>Earthing</b>	Obligated to use defined earthing material/method specified for the unit.  Minimum protective bonding conductor size of copper conductors: Wire: Minimum 1,5mm <sup>2</sup> but Hatteland Technology recommends 2,5mm <sup>2</sup> (AWG12) marked yellow/green.
<b>Outdoor</b>	Units with IP66/67-rated fronts can be used in outside environments, provided that the console they are fitted in fulfil certain requirements. <ul style="list-style-type: none"> <li>- There must be a fully water/dustproof seal between the IP66 front and the console.</li> <li>- Dust/water ingress protection of console. (Unit/product is rated for pollution degree 2).</li> <li>- Humidity/condensation control in console.</li> <li>- Thermal management in console (so units can operate within rated temperature range).</li> </ul> Units with IP20/IP22 shall not be used outdoor.
<b>Outdoor Installation</b>	Appropriate RCD with ground current rating of 20mA or less shall be used.

### Chassis Thermal / Heat note

Active HTC03 / HT20370 units might feel hot to the touch externally, this is normal and expected.

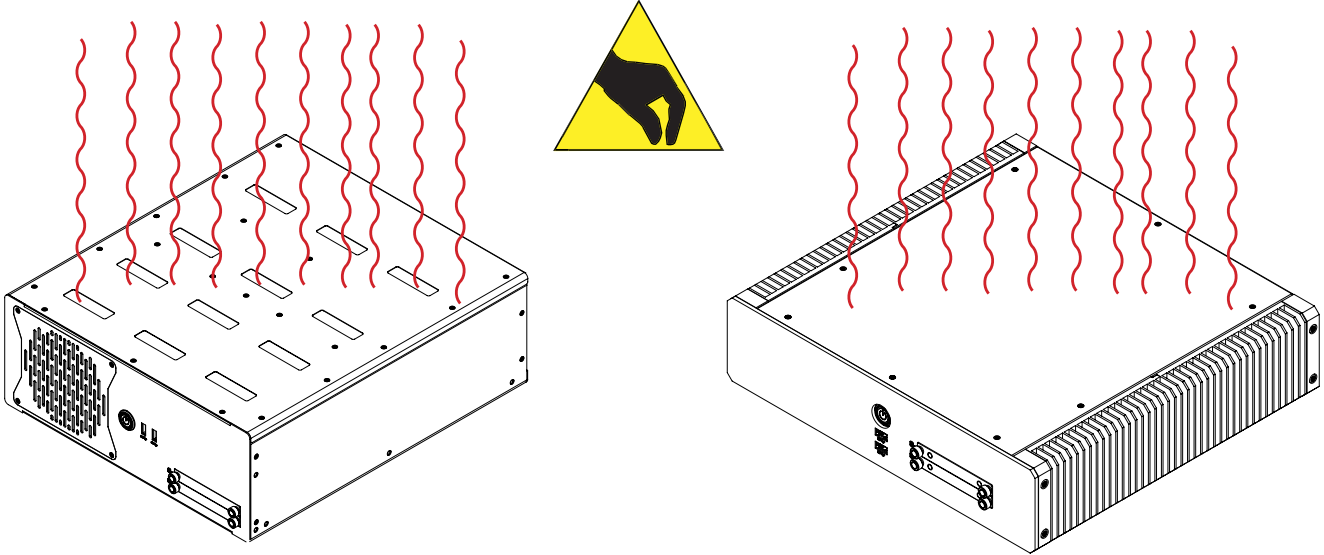

# HATTELAND TECHNOLOGY

an EMBRON Company 

## Declaration of Conformity

We, manufacturer, **Hatteland Technology AS**, Eikeskogvegen 52, N-5570 Aksdal, Norway

declare under our sole responsibility that the JH MMD, JH MMC, JH STD, JH MIL, HM NMD, HM MIL, HM CMD, HT STD, HD MMD, HD MVD, HM MMD, HM XRD, HM RMD, HT MMC, HD MMC, HT/HM (computers) and HN G (Network Switches) product ranges is in conformity with the following standards in accordance with the EMC Directive.

Low Voltage Directive 2014/35/EU  
EN 62368-1:2014;A11:2017  
EMC Directive 2014/30/EU  
EN 55032:2015  
EN 55035:2017  
EN 55024:2010+A1:2015  
EN IEC 63000:2018

Signature:.....

Frode Grindheim  
Vice President Product Management  
Aksdal, Norway

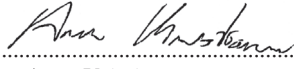

CE MARK FIRST AFFIXED DATE (11 March 2010)

Signature:.....

Arne Kristiansen  
Site Manager - Test & Commission Division  
Oslo, Norway

## Declaration of Conformity

We, manufacturer, **Hatteland Technology AS**, Eikeskogvegen 52, N-5570 Aksdal, Norway

declare under our sole responsibility that the JH MMD, JH MMC, JH STD, JH MIL, HM NMD, HM MIL, HM CMD, HT STD, HD MMD, HD MVD, HM MMD, HM XRD, HM RMD, HT MMC, HD MMC, HT/HM (computers) and HN G (Network Switches) product ranges is in conformity with IEC 60945 4th (EN 60945:2002) and IACS E10 (where applicable)

# HATTELAND TECHNOLOGY

an EMBRON Company 

## Declaration of Conformity

We, manufacturer, **Hatteland Technology AS**, Eikeskogvegen 52, N-5570 Aksdal, Norway

declare under our sole responsibility that the products listed below comply with  
FCC 47 CFR Part 15, Subpart B, Class A:

JH MMD, JH MMC, JH STD, JH MIL, HM NMD, HM MIL, HM CMD, HT STD, HD MMD, HD MVD, HM MMD, HM XRD, HM RMD, HT MMC, HD MMC, HT/HM (computers) and HN G (Network Switches) product ranges

Note: This equipment has been tested and found to comply with the limits for a Class A digital device, pursuant to part 15 of the FCC Rules. These limits are designed to provide reasonable protection against harmful interference when the equipment is operated in a commercial environment. This equipment generates, uses, and can radiate radio frequency energy and, if not installed and used in accordance with the instruction manual, may cause harmful interference to radio communications. Operation of this equipment in a residential area is likely to cause harmful interference in which case the user will be required to correct the interference at his own expense.

Signature:.....

Frode Grindheim  
Vice President Product Management  
Aksdal, Norway



FCC MARK FIRST AFFIXED DATE (16 February 2012)

Signature:.....

Arne Kristiansen  
Site Manager - Test & Commission Division  
Oslo, Norway

# Return Of Goods Information

## Return of goods:

*(Applies not to warranty/normal service/repair of products)*

Hatteland Technology referenced as “manufacturer” in this document.

Before returning goods, please contact your system supplier before sending anything directly to manufacturer. When you return products after loan, test, evaluation or products subject for credit, you must ensure that all accessories received from our warehouse are returned. This applies to cables, powermodules and additional equipment except screws or similar, user manual, datasheets or other written paper documents. Furthermore, the product must not have any minor / medium or severe scratches, chemical spills or similar on the backcover, front frame or glass.

This is required in order to credit the invoice 100%. Missing parts will not be subject for credit, and you will not get total credit for returned product. You will either be charged separately, or the amount is withdrawn from the credit. If you decide to ship the missing items later on, you will get 100% credit for that particular invoice or items received at manufacturer incoming goods control. Please contact our Repair Centre if additional questions or review the following links at bottom of page for more information online.



## Handling and packing units for return/credit

To prevent damage during shipping and transportation, respect the guidelines below.

### Make sure you surround the product with the following material (whenever possible):

Use the original packaging from manufacturer, firm foam material, bubble wrap, lots of PadPack paper or foam chips/polyester wrapped in sealed plastic bags. Please make sure that the unit is protected with a surrounding plastic bag to prevent dust accumulation around the unit.

If you do not have the original packaging or are uncertain as to how to secure the unit properly, please consider seeking advice from nearby shipping or transportation offices, if in doubt!

Do not under any circumstances use loose foam chips, expanded polyester, clothes, cardboard with sharp edges/spikes, too little or nothing to secure the unit inside the box. Do not use cardboard boxes that are clearly too weak or not suitable for securing the unit properly during overseas shipment.

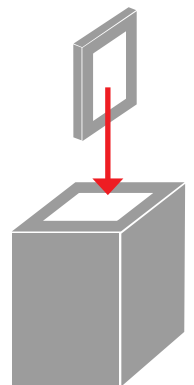

## How to issue a Return merchandise authorization (RMA):

Hatteland Technology requires a pre-registered CDV number prior to sending goods for return. If you do not have an pre-registered CDV number, please visit the links below on how to get one.

<https://www.hattelandtechnology.com/rma-procedure>

Once understood, proceed to registering RMA:

<http://lcm.hatteland-display.com/CustomerRMA/CustomerRMA.aspx>

Additional information:

<https://www.hattelandtechnology.com/legal-documents>

# General Terms and Conditions

As of January 2015, Hatteland Technology AS' "Terms of Sales and Delivery" and "Warranty Terms" have been substituted by the updated "General terms and conditions for sale of goods and performance of additional services" (the "General Terms and Conditions").

Further, from January 2015 onward, the previous "Terms of Sales and Delivery" and "Warranty Terms", as well as other standard terms and conditions, policies and instructions issued by Hatteland Technology AS, will be removed from the User Manuals.

Instead, the updated General Terms and Conditions and the other standard terms and conditions, policies and instructions issued by Hatteland Technology AS will be available via our website only.

Please visit <https://www.hattelandtechnology.com/legal-documents#terms-and-conditions> to review the latest revision

## Long Term Storage Recommendations

For Minimum storage life for Hatteland Technology products, Storage Conditions, Periodic maintenance - test procedure, please visit:

[https://www.hattelandtechnology.com/hubfs/pdf/misc/ind100350-5\\_long\\_term\\_storage\\_recommendations.pdf](https://www.hattelandtechnology.com/hubfs/pdf/misc/ind100350-5_long_term_storage_recommendations.pdf)

## INSTRUCTIONS FOR THE CONSIGNEE

### 1) CONTROL

Control the goods immediately by receipt. Examine the quantity against the invoice/packinglist/shipping documents. Look for outward defects on the packing which may indicate damage on or loss of contents. Control the container and the seals for any defects.

### 2) SECURING EVIDENCE

When defects on the goods have been found, evidence must be secured, and seller must be informed. Call the transporter and point out the defects. Add a description of the defects on the goods receipt, the forwarder's copy of the way-bill or on the driving slip.

### 3) RESCUE

Try to restrict the damage and the loss. Seller will compensate expenses incurred due to reasonable security efforts in addition to damage and loss.

### 4) COMPLAINT

Immediately write a complaint to the transporter or his agent. Immediately forward the complaint to the transporter or his agent, and hold the transporter responsible for the defects. The complaint must be sent at the latest:

- for carriage by sea: within 3 days
- for overland / air transportation within 7 days

### 5) DOCUMENTATION

For any claims the following documentation is required and must be forwarded to the company or their agent: invoice, way-bill and/or bill of landing, and/or statement of arrival, inspection document, besides a copy of the letter of complaint to the transporter.

## General Notes:

- License Terms for the installed OEM Operating System (OS) can be found in the following default factory paths:  
Note: This is a general listing for a variety of OS's Hatteland Technology can factory install depending on unit.  
Please check specification for your unit to verify type of OS installed in order to retrieve the license terms listed below.

Microsoft® Windows® 10 IoT Enterprise LTSC 2019: C:\Windows\System32\en-US\Licenses\_Default\EnterpriseS\license.rtf



# Revision History

Please note that references to page numbers may only be valid for the latest revision.

Rev.	By	Date	Notes
00_01	MS	30 Sep 2020	Release for internal reviews
00_02	JE SE	31 Dec 2020	Revised after internal reviews
00_03	JE BB SE	08 Jan 2021	Revised after internal reviews
00_04	JE SE MS	24 Feb 2021	Revised after internal reviews
00_05	VM SE	10 Mar 2021	Revised after internal reviews
01	ALL SE	12 Apr 2021 14 Apr 2021	Release for internet
02	SHL SE	28 May 2021	Added new Multi-Power model throughout the entire manual
03	CH SE	17 Aug 2021 18 Aug 2021	Added Module Matrix overview, page 41-44 Added note for chassis heat, page 148
04	VM GM SE	23 Nov 2021	Revised screw/screwdriver details, page 22-27 Added Factory Preset COM Port Numbering, page 44 Added section for WatchDog function, page 138-139



## Revision History



# HATTELAND TECHNOLOGY

an EMBRON Company 