



# ***Fuel/Air Systems***



WINDSHIELDS & FAIRINGS

AUDIO & VIDEO

SADDLEBAGS & LUGGAGE

SEATS & SISSY BARS

EXHAUST

FUEL/AIR SYSTEMS

ENGINE

TRANSMISSION & DRIVELINE

GASKETS & SEALS

ELECTRICAL

LIGHTING

HANDLEBARS, CONTROLS & MIRRORS

CABLES

BRAKES

TANKS & OIL FILTERS

DASHES & GAUGES

FRAMES & SUSPENSION

FENDERS & LICENSE PLATE FRAMES

FOOTRESTS

WHEELS & AXLES

HARDWARE, COVERS & GENERAL

**POWER VISION**

- The quickest, most powerful flash tuner on the market
- The sophisticated, yet easy-to-use, 3.5" full-color touch-screen display mounts to handlebars with integrated Amps 4-hole threaded inserts; also mounts to most aftermarket accessory mounts that feature AMPS 4-mounting options
- The display's interface cable plugs directly to the bike's diagnostic connector
- NO COMPUTER REQUIRED; simply select the tune and follow the on-screen prompts
- to flash the bike; tunes can also be edited directly from the Power Vision
- Utilizes WinPV (Windows PC-based tuning application)
- Stores up to six different tunes that can be flashed to the bike
- Downloads and stores the stock calibration in case OEM restoration is needed; stock calibration can also be saved as an editable copy and used as a starting point
- Dynojet preconfigured tunes are preloaded on the unit; Power Vision will identify the bike's information and automatically sort hundreds of applicable, dyno-proven tunes
- Custom tunes can be loaded by a tuning shop or received via email and loaded onto the device
- Displays all J1850 H-D vehicle data, wide-band air fuel ratio<sup>2</sup> and various calculated channels (including MPG instant and trip MPG)
- AutoTune Basic and Pro<sup>3</sup> calculates and stores fuel trims to optimize fuel curve
- Checks and clears diagnostic codes
- Features adaptive trims and idle offset (with bike running)
- Black series features a flat black outer case
- See Dynojet website <http://www.dynojet.com/power-vision-tune-license-programs.aspx> for information about purchasing additional Power Vision tune licenses.



**MANUFACTURER'S NOTE:** All Power Vision returns and/or adjustments must be made directly with Dynojet Research. The Power Vision may be used on any bike to read and clean trouble codes.

PART #	DESCRIPTION	SUG. RETAIL
<b>ORIGINAL</b>		
1020-1493	For all H-D models with Delphi EFI (except 11-16 FXS/FLS/FLST, 12-16 Dynas, 14-16 Dressers and 14-16 XL models)	\$549.95
1020-1494	For 11-17 FXS/FLS/FLST, 12-16 Dyna models, 14-16 FLHT/FLHX/FLHR and 14-16 XL and 15-16 XG models	549.95
<b>BLACK SERIES</b>		
1020-2324	For all H-D models with Delphi EFI (except 11-16 FXS/FLS/FLST, 12-16 Dynas, 14-16 Dressers, 14-16 XL, and 15-16 XG models)	549.95
1020-2325	For 11-17 FXS/FLS/FLST, 12-16 Dyna models, 14-16 FLHT/FLHX/FLHR, 14-16 XL, and 15-16 XG models	549.95

**POWER VISION VISOR**

- Quick-release ability to remove or attach the Power Vision to the Techmount
- "NutSerts" are embedded and allow you to attach the visor/quick clip to mounting systems or any other system with a 4-hole pattern
- Shades display screen, improving screen visibility
- Available in flat black or black chrome



PART #	DESCRIPTION	SUG. RETAIL	PART #	DESCRIPTION	SUG. RETAIL
1020-2045	Power vision visor (flat black)	\$19.95	1020-2046	Power vision visor (black chrome)	\$19.95

**POWER COMMANDER V**

- Fuel and timing control
- Rev Xtend increases Rev limit
- The Power Commander V can read the exact engine temperature through the bike's ECM, which allows the tuner to choose how much fuel to add during cold starts
- Cold starting on heavily modified engines should be more controllable and easy to adjust
- USB powered from computer
- Two position map-switching function built-in (switch not included)
- Can add any SPST switch and toggle between two different fuel/timing maps
- Gear/speed input allows for map adjustment based on gear
- Analog input allows user to install any 0-5 volt sensor
- Build an adjustment table based on analog input, such as boost or temperature
- Power Commander V is capable of allowing each cylinder to be mapped individually and for each gear with the gear position input connected
- Ten throttle position columns
- World's largest dyno tested map database
- Enhanced "accel pump" utility
- Made in the U.S.A.



PART #	DESCRIPTION	SUG. RETAIL	PART #	DESCRIPTION	SUG. RETAIL
1020-2666	For 17 FLHT/FLHX/FLHR/FLTRX	\$399.95	1020-1871	For 04-05 Dyna Glide	\$399.95
1020-2068	For 14-16 FLHT/FLHX/FLHR/FLTR	399.95	1020-2072	For 14-16 XL883	399.95
1020-1121	For 08-13 FLHT/FLHX/FLHR/FLTR	399.95	1020-1118	For 10-13 XL883	399.95
1020-1868	For 07 FLHT/FLHX/FLHR/FLTR	399.95	1020-0839	For 07-09 XL883	399.95
1020-1867	For 02-06 FLHT/FLHX/FLHR/FLTR	399.95	1020-2071	For 14-16 XL1200	399.95
1020-2460	For 97-01 FLHT/FLHX/FLHR/FLTR	419.95	1020-1119	For 10-13 XL1200	399.95
1020-2502	For 16 FLS/FLST	399.95	1020-0840	For 07-09 XL1200	399.95
1020-1555	For 12-15 FXS/FLS/FLST (except 12-15 CVO models)	399.95	1020-1120	For 09-12 XR1200	399.95
1020-0842	For 07-11 FXST/FLSTF/FXCW (except 11 CVO models)	399.95	1020-1557	For 12-16 V-Rod	399.95
1020-1869	For 01-06 FXST/FLST	399.95	1020-0844	For 08-11 V-Rod	399.95
1020-0940	For 07-11 FLSTC/FLSTN	399.95	1020-1870	For 02-07 V-Rod	399.95
1020-1556	For 12-16 Dyna Glide	399.95	1020-2261	For 15-16 Street 500	399.95
1020-0843	For 06-11 Dyna Glide	399.95	1020-2262	For 15-16 Street 750	399.95

**DISCLAIMER:** NOT LEGAL FOR SALE OR USE IN CALIFORNIA ON ANY POLLUTION CONTROLLED MOTOR VEHICLES. SEE PAGE 399 FOR IMPORTANT EMISSION DEFINITIONS AND REGULATORY COMPLIANCE AND WARRANTY INFORMATION.

All part numbers in BLUE are new for 2017.

WINDSHIELDS  
& FAIRINGS

AUDIO &amp; VIDEO

SADDLEBAGS  
& LUGGAGESEATS &  
SISSY BARS

EXHAUST

FUEL/AIR  
SYSTEMS

ENGINE

TRANSMISSION  
& DRIVELINEGASKETS  
& SEALS

ELECTRICAL

LIGHTING

HANDLEBARS,  
CONTROLS  
& MIRRORS

CABLES

BRAKES

TANKS &  
OIL FILTERSDASHES  
& GAUGESFRAMES &  
SUSPENSIONFENDERS  
& LICENSE  
PLATE FRAMES

FOOTRESTS

WHEELS  
& AXLESHARDWARE,  
COVERS &  
GENERAL**DynaJet****POWER COMMANDER V-PTI**

- Uses the same great features as the Power Commander V, but is perfect for turbocharged or supercharged applications looking for precision, control and reliability
- Modify your fuel curve based off a pressure (boost) table and/or temperature table
- Pressure table provides 3D mapping capability based on boost vs. rpm
- Temperature table provides 2D mapping capability with up to 50 points of adjustments
- Comes with a Bosch 3 bar map/temp sensor

PART #	DESCRIPTION	SUG. RETAIL	PART #	DESCRIPTION	SUG. RETAIL
<b>1020-2395</b>	For 14-16 FLHT/FLHX/FLTRX models	<b>\$469.95</b>	<b>1020-1818</b>	For 08-11 V-Rod models	<b>\$469.95</b>
<b>1020-1938</b>	For 08-13 FLHT/FLHX/FLHR/FLTR models	<b>469.95</b>	<b>1020-1820</b>	For 06-11 Dyna Glide models	<b>469.95</b>
<b>1020-2457</b>	For 12-15 FXS/FLS/FLST models	<b>469.95</b>	<b>1020-1819</b>	For 10-13 XL1200 models	<b>469.95</b>
<b>1020-1817</b>	For 07-11 FXST/FLST models	<b>469.95</b>	<b>1020-2601</b>	For 07-09 XL1200 models	<b>469.95</b>

**POWER COMMANDER V EX**

- Offers virtually the same tuning functionality and installation ease as the Power Commander V line
- Develop custom maps the same way as the PC-V version
- Load "race only" Power Commander models into the PC-V EX
- Automatically converts to the proper format

**NOTE:** Exempt per CARB EO #D-619-2 Appendix A on many models for some years 2001-2014

PART #	DESCRIPTION	SUG. RETAIL	PART #	DESCRIPTION	SUG. RETAIL
<b>1020-2133</b>	For 14-16 FLHR/FLHTCU/FLHTK/FLHX/FLHXS	<b>\$399.95</b>	<b>1020-1889</b>	For 10-13 XL883	<b>\$399.95</b>
<b>1020-1499</b>	For 08-13 FLHT/FLHX/FLHR/FLTR	<b>399.95</b>	<b>1020-1496</b>	For 07-09 XL883	<b>399.95</b>
<b>1020-1500</b>	For 07-11 FXST/FLST	<b>399.95</b>	<b>1020-2122</b>	For 14-15 XL1200	<b>399.95</b>
<b>1020-2525</b>	For 16 FLS/FLST	<b>399.95</b>	<b>1020-1890</b>	For 10-13 XL1200	<b>399.95</b>
<b>1020-1788</b>	For 12-15 FXS/FLS/FLST	<b>399.95</b>	<b>1020-1497</b>	For 07-09 XL1200	<b>399.95</b>
<b>1020-1501</b>	For 06-11 Dyna Glide	<b>399.95</b>	<b>1020-1502</b>	For 08-11 V-Rod	<b>399.95</b>
<b>1020-1789</b>	For 12-16 Dyna Glide	<b>399.95</b>	<b>1020-2524</b>	For 15-16 Street 500	<b>399.95</b>
<b>1020-2132</b>	For 14-15 XL883	<b>399.95</b>			

**POWER COMMANDER V MAP SELECT SWITCH**

- Switches between two different maps that have been pre-loaded in a Power Commander V
- Comes with a switch, wiring and instructions
- Universal mount

PART #	DESCRIPTION	SUG. RETAIL
<b>1020-2082</b>	Map select switch	<b>\$49.95</b>

**DISCLAIMER:** NOT LEGAL FOR SALE OR USE IN CALIFORNIA ON ANY POLLUTION CONTROLLED MOTOR VEHICLES. SEE PAGE 399 FOR IMPORTANT EMISSION DEFINITIONS AND REGULATORY COMPLIANCE AND WARRANTY INFORMATION.

All part numbers in **BLUE** are new for 2017.



SECTION 6

WINDSHIELDS & FAIRINGS

AUDIO & VIDEO

SADDLEBAGS & LUGGAGE

SEATS & SISSY BARS

EXHAUST

FUEL/AIR SYSTEMS

ENGINE

TRANSMISSION & DRIVELINE

GASKETS & SEALS

ELECTRICAL

LIGHTING

HANDLEBARS, CONTROLS & MIRRORS

CABLES

BRAKES

TANKS & OIL FILTERS

DASHES & GAUGES

FRAMES & SUSPENSION

FENDERS & LICENSE PLATE FRAMES

FOOTRESTS

WHEELS & AXLES

HARDWARE, COVERS & GENERAL

**AUTOTUNE KIT FOR POWER VISION**

- Plugs directly into the Power Vision with a single cable
- Includes 18mm O<sub>2</sub> sensors and power connector that plugs into the bike's harness
- Provides real-time AFR feedback to the Power Vision
- Allows for semi-automated fuel corrections
- User can specify what air/fuel ratio to make each rpm and throttle position percentage combination
- Makes it possible to adjust cruise for best fuel economy as well as larger throttle openings for peak power
- Base settings included for air/fuel ratios, but are fully adjustable if need be
- Made in the U.S.A.

**NOTE:** Because of possible clearance issues, some aftermarket exhaust systems may require modifications or relocation of their sensor bungs.

PART #	DESCRIPTION	SUG. RETAIL
1020-1532	For use with Power Vision PART #1020-1493, 2324	\$494.95
1020-1533	For use with Power Vision PART #1020-1493, 2324; includes weld-in 18mm bungs	509.95
1020-1535	For use with Power Vision PART #1020-1494, 2325; includes weld-in 18mm bungs	429.95



1020-2522



1020-2523

**POWER VISION TUNER KITS**

- Tune multiple bikes using just one Power Vision and AutoTune Pro Module
- Dyno Tuner Kit designed for Dynojet dynos equipped with the Gen4 exhaust pump
- Shop Tuner Kit designed for shops without a Dynojet dyno or Gen4 exhaust pump
- Include Power Vision, AutoTune Pro Module with plug-in power supply, and all necessary cables in order to tune J1850 or CAN models
- Requires installation of the most recent version of WinPV on your computer to take advantage of new features; WinPV can be updated using the Power Vision Update Client from the Dynojet website
- You will need to create an online account to use the new WinPV 2.0 Online License software; once you create an account, you are ready to purchase license credits at any time

**NOTE:** For shop use only; no retail pricing available

PART #	DESCRIPTION	PART #	DESCRIPTION
1020-2522	Dyno Tuner Kit	1020-2523	Shop Tuner Kit

**DISCLAIMER:** NOT LEGAL FOR SALE OR USE IN CALIFORNIA ON ANY POLLUTION CONTROLLED MOTOR VEHICLES. SEE PAGE 399 FOR IMPORTANT EMISSION DEFINITIONS AND REGULATORY COMPLIANCE AND WARRANTY INFORMATION.

All part numbers in BLUE are new for 2017.



WINDSHIELDS & FAIRINGS

AUDIO & VIDEO

SADDLEBAGS & LUGGAGE

SEATS & SISSY BARS

EXHAUST

**AUTO TUNE KIT FOR POWER COMMANDER V**

- Plugs directly into the Power Commander V with a single cable
- Includes 18mm O<sub>2</sub> sensors and power connector that plugs into the bike's harness
- Makes automatic fuel adjustments
- User can specify what air/fuel ratio to make each rpm and throttle position percentage combination
- Makes it possible to adjust cruise for best fuel economy as well as larger throttle openings for peak power
- Base settings included for air/fuel ratios, but are fully adjustable if need be
- Made in the U.S.A.



**NOTE:** Because of possible clearance issues, some aftermarket exhaust systems may require modifications or relocation of their sensor bungs.

PART #	DESCRIPTION	SUG. RETAIL
1020-1559 <sup>1</sup>	For 14-16 Dressers, 12-15 FXS/FLS/FLST, Dyna Glide and 12-16 XL models w/ CAN-bus connector	\$479.95
1020-1117 <sup>1</sup>	For 10-13 Dresser models with 12mm O <sub>2</sub> sensor (except FXST/FLST, Dyna Glide models)	479.95
1020-0857	For all models with 18mm O <sub>2</sub> sensors (except 11 FXST/FLST models)	469.95
1020-1558	For 11 FXS/FLST models w/ CAN-bus connector	469.95

<sup>1</sup> Requires installation of two 18mm sensor bungs (included).

FUEL/AIR SYSTEMS

**TARGET TUNE**

- Allows the factory ECM to interpret and use wideband O<sub>2</sub> sensor signals
- Target fuel table from the calibration is achieved in real time
- Retains OEM closed loop and achieves adaptive fuel control strategy
- Learns and uses VE table corrections as you ride
- Does not interfere with dealer diagnostic/service tools
- Includes OEM style connectors to plug into factory O<sub>2</sub> harness, either 2 or 4 pin versions
- Available with or without O<sub>2</sub> sensor



1020-2483

ENGINE

TRANSMISSION & DRIVELINE

PART #	DESCRIPTION	SUG. RETAIL	PART #	DESCRIPTION	SUG. RETAIL
<b>WITH O<sub>2</sub> SENSORS</b>			<b>WITHOUT O<sub>2</sub> SENSORS</b>		
1020-2483	For 07-09 Dressers, 07-11 FXST/FLST (except 07-11 CVO models), 06-11 Dyna Glide, 08-11 V-Rod, and 07-13 XL models	\$599.95	1020-2484	For 07-09 Dressers, 07-11 FXST/FLST (except 07-11 CVO models), 06-11 Dyna Glide, 08-11 V-Rod, and 07-13 XL models	\$299.95
1020-2485	For 10-13 Dresser models	599.95	1020-2486	For 10-13 Dresser models	299.95
1020-2487	For 12-16 V-Rod models	599.95	1020-2488	For 12-16 V-Rod models	299.95
1020-2489	For 12-16 FXST/FLST and 12-16 Dyna Glide models	599.95	1020-2490	For 12-16 FXST/FLST and 12-16 Dyna Glide models	299.95
1020-2491	For 14-16 Dresser models	599.95	1020-2492	For 14-16 Dresser models	299.95
1020-2495	For 14-16 XL models	599.95	1020-2496	For 14-16 XL models	299.95
1020-2493	For 15-16 XG 500/750 models	599.95	1020-2494	For 15-16 XG 500/750 models	299.95

GASKETS & SEALS

ELECTRICAL

LIGHTING

HANDLEBARS, CONTROLS & MIRRORS

CABLES

BRAKES

TANKS & OIL FILTERS

DASHES & GAUGES

FRAMES & SUSPENSION

FENDERS & LICENSE PLATE FRAMES

FOOTRESTS

WHEELS & AXLES

HARDWARE, COVERS & GENERAL

**MULTI-FUNCTION HUB ACCESSORY FOR POWER COMMANDER USB/USB-EX**

- The Multi-Function Hub allows access to advanced expansion features of the Power Commander USB
- Compatible with the LCD display, but the display is not required
- Four separate functions can be accessed with the Multi-Function Hub
- The Map Selection Switch (7/8" bar mount) allows the rider to switch between two different maps in the Power Commander; this allows a map for economy, and a separate map for performance
- The Gear Position/Speed function allows fuel and timing adjustments to be made depending on the gear selected and the position of the throttle, up to +/-50% fuel and +/-10 degrees of timing
- Pressure input allows the fuel to be increased, along with the boost level on turbocharged installations; the change of boost level does not require a re-mapping of the Power Commander
- Relay outputs allow up to two warning lights or relays to be triggered independently to activate items such as shift lights, nitrous systems, or air shifter; the trigger can be by throttle percent, rpm, or both
- Comes complete with installation instructions, wiring diagrams and CD with the required software updates
- Made in the U.S.A.

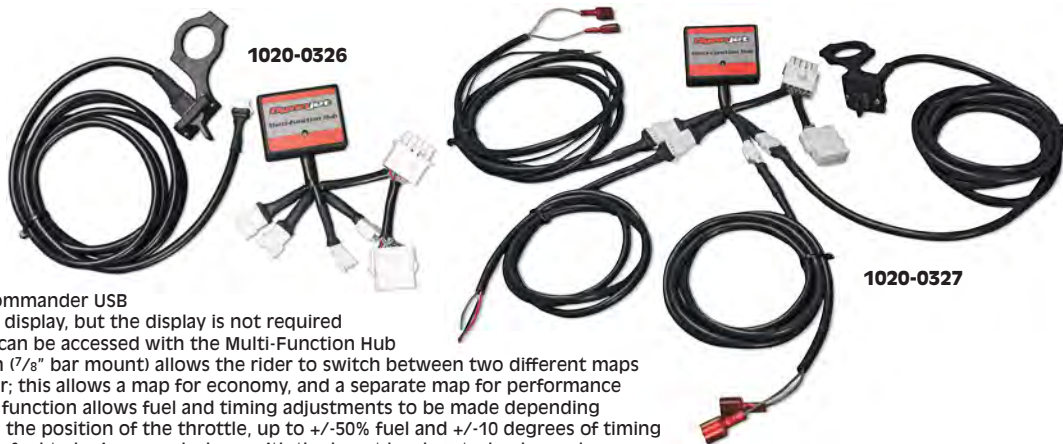

1020-0326

1020-0327

PART #	DESCRIPTION	SUG. RETAIL
1020-0326	Multi-Function Hub and wiring harness for Map Selection Switch only	\$179.95
1020-0327	Multi-Function Hub and wiring harness for Map Selection, Gear Position, Speed sensor, Pressure Input and two relay outputs	219.95

**POD-300 DIGITAL DISPLAY**

- Real time fuel adjustment
- Display channels real-time: RPM, TP, map position (when using map switch), duty cycle, fuel exchange, Ignition change and wideband air/fuel ratio (w/ WB2 or auto-tune connected)
- Weather resistant for use in all conditions
- Log channels saved to internal memory and can be viewed/analyzed with Dynojet's powercore software
- High contrast display, viewable in sunlight
- Includes CAN cable for attachment to Power Commander V, Auto Tune and Wide Band Power Commander



PART #	DESCRIPTION	SUG. RETAIL
1020-2371	POD-300 digital display	\$249.95

**NOTE:** Not for use with Power Commander III USB.  
**DISCLAIMER:** NOT LEGAL FOR SALE OR USE IN CALIFORNIA ON ANY POLLUTION CONTROLLED MOTOR VEHICLES. SEE PAGE 399 FOR IMPORTANT EMISSION DEFINITIONS AND REGULATORY COMPLIANCE AND WARRANTY INFORMATION.

All part numbers in **BLUE** are new for 2017.

TECHNORESEARCH

WINDSHIELDS & FAIRINGS

AUDIO & VIDEO

SADDLEBAGS & LUGGAGE

SEATS & SISSY BARS

EXHAUST

FUEL/AIR SYSTEMS

ENGINE

TRANSMISSION & DRIVELINE

GASKETS & SEALS

ELECTRICAL

LIGHTING

HANDLEBARS, CONTROLS & MIRRORS

CABLES

BRAKES

TANKS & OIL FILTERS

DASHES & GAUGES

FRAMES & SUSPENSION

FENDERS & LICENSE PLATE FRAMES

FOOTRESTS

WHEELS & AXLES

HARDWARE, COVERS & GENERAL

MAXIMUS

MAXIMUS TUNER

- Most advanced, easy-to-operate single-user flash tuning tool for ALL fuel-injected Harley-Davidsons
- User-friendly Android smartphone and tablet app allows users an easy-to-use display in real time that wirelessly communicates via Bluetooth
- Utilizes advanced hardware and software specifications to combine the most commonly used features from the Centurion Pro professional diagnostics tool as well as the Direct Link professional flash tuning tool
- Easy hookup with included cables
- Once tuning is complete, the kit is simply unplugged until the next tune
- Maximus allows backing up and restoring original maps, as well as re-flashing stock ECUs and performing routine diagnostics
- Fast data acquisition and many hours of data storage provides accuracy and saves time
- Provides power from the motorcycle for wideband O<sub>2</sub> sensors and will record/monitor wideband O<sub>2</sub> sensors
- Tuning features include the ability to modify front and rear cylinder fuel/spark tables separately, air/fuel ratio, warm-up fuel, cranking fuel, closed loop, acceleration/deceleration, rev limiter and the ability to restore original map
- Easy-to-use auto mapping feature
- Diagnostic features include key fob coding, speedometer calibration, read and clear diagnostic trouble codes (DTC), and system relay testing
- Requires the use of Windows-based PC, laptop or tablet
- Made in the U.S.A.



NOTE: Can be used on one motorcycle an unlimited amount of times, but not multiple bikes.

PART #	DESCRIPTION	SUG. RETAIL
1020-2423	For 11-13 Softail, 12-13 Dyna and all 14-17 models w/ CAN data bus (except 14-17 V-Rod) (6-pin connector)	\$452.95
1020-2410	For 01-13 models w/ Delphi EFI (J1850), 01-17 V-Rod and 97-00 models w/ Marelli EFI (4-pin connector)	452.95



CENTURION SUPER PRO AND SUPER PRO PLUS PROFESSIONAL TUNING AND DIAGNOSTIC TOOLS

- The industry's only complete professional diagnostic tool system designed for independent professional repair facilities
- Communicates with ALL 97-17 Harley-Davidson and Buell models using the included proprietary VCM-TR3 Communication Module with included cables
- Re-flash blank ECU, program VIN, BCM and Key Fobs
- Centurion recovers locked security modules (TSSM/BCM) without costly replacements of TSSM or BCM
- Perform radio, speaker, lighting and navigation system configuration on all models
- Easily perform speedometer calibration on all models
- ABS bleeding and solenoid testing
- Read and clear Diagnostic Trouble Codes (DTC)
- Reset air/fuel values and adjust idle rpm
- Perform active tests on tachometer, speedometer, fuel pump, idle rpm, system relays, cooling fans, alarm, IAC, ACR compression, injector coils, coolant pump, left or right turn signals and other systems
- Centurion Super Pro Plus equals in functionality with OEM Indian and Victory diagnostics
- LED indicator tests for 6th gear, ABS service, battery, check engine, cruise control, high and low beam, neutral, oil, security and coolant temp
- View real-time data in strip chart or digital dashboard formats
- Requires use of a Windows or Android-based PC, laptop or tablet; connect using either included cable or Bluetooth® wireless connection
- Fast data acquisition and many hours of data storage provides accuracy and saves time
- Can easily update software online through Technoresearch to stay current on all features, years and model types
- Included VCM-TR3 Communication Module is fully compatible with Direct Link & Tune Builder keys (sold separately)
- Includes Mobile Dyno with Android app that provides more than 20 hours of data logging
- Durable metal housing and easy adapter system allowing for fast switches between motorcycles
- Made in the U.S.A.



PART #	DESCRIPTION	SUG. RETAIL
3807-0313	For 97-17 H-D and Buell models	\$1,999.95
3807-0314	For 97-17 H-D and Buell models, Victory and Indian models (all)	2,126.95

DISCLAIMER: NOT LEGAL FOR SALE OR USE IN CALIFORNIA ON ANY POLLUTION CONTROLLED MOTOR VEHICLES. SEE PAGE 399 FOR IMPORTANT EMISSION DEFINITIONS AND REGULATORY COMPLIANCE AND WARRANTY INFORMATION.

All part numbers in BLUE are new for 2017.

# TECHNO RESEARCH

- WINDSHIELDS & FAIRINGS
- AUDIO & VIDEO
- SADDLEBAGS & LUGGAGE
- SEATS & SISSY BARS
- EXHAUST

## DIRECT LINK TUNING KEYS

- Provide the most extensive, professional, easy-to-use flash tuning capabilities available
- For use with any Technoresearch VCM-TR3 (Centurion Pro, Pro Plus or Tune Builder)
- Direct Link's included Auto Mapping feature greatly reduces the user's need to do cell-by-cell tuning calculations
- Allow tuners to modify fuel and spark tables (front and rear cylinders), air fuel ratio, warm-up fuel, cranking fuel, closed loop, acceleration and deceleration, rev limiter and knock control
- Fuel, spark and AFR real-time cell tracing
- Simultaneous modification of both front and rear cylinder fuel and spark tables
- View data using Strip Chart or Digital Dashboard
- Data logging and data analysis features
- Save back-up with calibrations and restore the original map
- Wideband O<sub>2</sub> sensor controller interfacing
- Motorcycle's VIN is assigned to one key and can be used for multiple tunes
- Made in the U.S.A.



PART #	DESCRIPTION	SUG. RETAIL
<b>1020-2411</b>	For all Harley-Davidson models w/ Delphi EFI	\$318.95
<b>1020-2412</b>	For all Harley-Davidson models w/ Marelli EFI	318.95

## VICTORY/INDIAN CENTURION PRO UPGRADE KIT

- Kit includes all cables and hardware needed to upgrade a Centurion Pro kit (PART # 3807-0313) to include Victory and Indian features
- Activation code included inside package to easily unlock features



PART #	DESCRIPTION	SUG. RETAIL
<b>3807-0344</b>	Upgrade kit	\$428.95

## TUNE BUILDER

- Tune Builder is an easy-to-use, professional tuning aid that saves up to 50% of the time needed to create mapping
- Quickly combines current map information with using its powerful data collection and sophisticated algorithms to automatically create tables that allows users to copy/paste completed maps into flash tuning software
- After data is collected from a motorcycle ECU, Tune Builder's Auto Mapping feature automatically generates fuel tables to create the most efficient map possible
- Can be used with all flash tuning software regardless of brand, including OE and aftermarket products
- Effortlessly tune Volumetric Efficiency (VE) tables, detect and remove spark knock and evaluate engine usage areas
- Log up to 16 channels simultaneously and at high frequency
- Record and seamlessly integrate any O<sub>2</sub> sensor device into data collection
- Can utilize the motorcycle's stock narrow band O<sub>2</sub> sensors (if equipped)
- View 3D plots in a grid or in color and view statistics on collected data
- View and adjust tables simply
- Easy to apply manual corrections of VE and spark tables
- Can apply changes to front and rear tables simultaneously
- Keys are available with either 5 or 10 licenses; one license used per motorcycle
- Made in the U.S.A.



**NOTE:** Must be used in conjunction with a fuel management system previously installed on the bike.  
**NOTE:** PART #1020-2409 includes VCM-TR3 communication hardware and cables. License keys need to be purchased separately.  
**NOTE:** If you have a Centurion Super Pro or Centurion Super Pro Plus, PART #1020-2409 is NOT needed.

PART #	DESCRIPTION	SUG. RETAIL	PART #	DESCRIPTION	SUG. RETAIL
<b>TUNE BUILDER HARDWARE</b>			<b>LICENSE KEYS</b>		
<b>1020-2409</b>	Tune Builder VCM (Vehicle Communication Module); no keys included	\$713.95	<b>1020-2413</b>	5 licenses	\$85.95 (ea.)
			<b>1020-2414</b>	10 licenses	85.95 (ea.)

- FUEL/AIR SYSTEMS
- ENGINE
- TRANSMISSION & DRIVELINE
- GASKETS & SEALS
- ELECTRICAL
- LIGHTING
- HANDLEBARS, CONTROLS & MIRRORS
- CABLES
- BRAKES
- TANKS & OIL FILTERS
- DASHES & GAUGES
- FRAMES & SUSPENSION
- FENDERS & LICENSE PLATE FRAMES
- FOOTRESTS
- WHEELS & AXLES
- HARDWARE, COVERS & GENERAL

## TRO<sub>2</sub> WIDEBAND AIR/FUEL RATIO SYSTEM

- Essential tuning assistant designed to be used with data logging systems such as a dyno or the Mobile Dyno feature from TechnoResearch found in Centurion Pro, Centurion Pro Plus and Tune Builder
- Includes two Bosch LSU 4.2 O<sub>2</sub> sensors with 7-foot long cables for easy and versatile usage
- Interfaces directly with any TechnoResearch VCM-TR3 communication module found with products such as Tune Builder, Centurion Pro, Centurion Pro Plus
- No calibration required with digital precision
- 12 volt DC power input required
- Made in the U.S.A.

**NOTE:** Use PART #3807-0378 to install O<sub>2</sub> sensor sensor bungs.



PART #	DESCRIPTION	SUG. RETAIL
<b>3807-0343</b>	Air/fuel ratio system	\$532.95

**DISCLAIMER:** NOT LEGAL FOR SALE OR USE IN CALIFORNIA ON ANY POLLUTION CONTROLLED MOTOR VEHICLES.  
 SEE PAGE 399 FOR IMPORTANT EMISSION DEFINITIONS AND REGULATORY COMPLIANCE AND WARRANTY INFORMATION.

All part numbers in **BLUE** are new for 2017.



WINDSHIELDS & FAIRINGS

AUDIO & VIDEO

SADDLEBAGS & LUGGAGE

SEATS & SISSY BARS

EXHAUST

FUEL/AIR SYSTEMS

ENGINE

TRANSMISSION & DRIVELINE

GASKETS & SEALS

ELECTRICAL

LIGHTING

HANDLEBARS, CONTROLS & MIRRORS

CABLES

BRAKES

TANKS & OIL FILTERS

DASHES & GAUGES

FRAMES & SUSPENSION

FENDERS & LICENSE PLATE FRAMES

FOOTRESTS

WHEELS & AXLES

HARDWARE, COVERS & GENERAL

**FUELPAK FP3**

- The Fuelpak FP3 has revolutionized fuel management for all new Harley-Davidson models using the HDLAN system
- Connecting wirelessly by Bluetooth® to any iPhone® or Android Smartphone, Fuelpak FP3 uses Flash technology to recalibrate engine parameters and mapping for exhaust systems and other performance upgrades downloaded from the expansive library of calibrations developed by Vance & Hines
- Also standard for the Fuelpak FP3 is an Autotune feature, making use of all factory sensors to add another layer of precision tuning for specific requirements, whether tuning for unique components or different grades of fuel
- With the Fuelpak FP3 module plugged-in, Live Sensor Data can be viewed through the smartphone to display speed, RPM, cylinder head temperature, voltage, gear selection and other vital information
- Features smartphone app user interface
- Displays live sensor data; PART # 1020-2538 excludes fuel economy, average fuel economy, gear and odometer



1020-2203



PART #	DESCRIPTION	SUG. RETAIL
<b>FP3 FUELPAK FOR 49 STATE USE</b>		
1020-2203	For all 14-17 FLHT/FLHX/FLHR/FLTRX, 11-17 FXS/FLS/FLST, 12-17 FXD/FXDWG, 14-17 XL, 15-17 XG models (including CVO models)	\$399.99
1020-2538	For all 07-13 FLHT/FLHX/FLHR/FLTRX, 07-10 FXST/FLST (including CVO models), 07-11 FLD/FXD/FXDWG, 08-11 FXCW/C, 07-13 XL/XR models	399.99
<b>FP3 FUELPAK CALIFORNIA A.R.B.</b>		
1020-2463 <sup>1</sup>	For 14-15 FLHT/FLHX/FLHR/FLTRX 11-15 FXS/FLS/FLST, 12-15 FXD/FXDWG, 14-15 XL, 15 XG models (including CVO models)	399.99

<sup>1</sup> EO #D-632-2 Appendix A (C.A.R.B. FUELPAK).

**FUELPAK**

- Available in original version which is not legal for sale or use in CA or California A.R.B; approved version with all the same features as the original
- Throttle position sensor-based system simplifies the process of fuel-injection tuning
- Enables you to fine-tune the fuel mixture throughout the entire rpm range with the touch of a button
- Increases power and improves throttle response
- Very user friendly; plugs into the existing harness on the bike
- No computer or software is required; simply punch in the values provided on the V&H website
- Values provided are for use with Vance & Hines exhaust systems
- Fuelpak will also work with other exhaust systems (contact V&H tech support for tuning information)
- Includes all necessary mounting hardware

NOTE: C.A.R.B. EO #D-632-1 for many 2007 and 2008 HD models.

NOTE: Requires the use of a high-performance air filter.



1020-1521



1020-0538



PART #	DESCRIPTION	SUG. RETAIL
<b>LCD FUELPAK FOR 49 STATE USE</b>		
1020-1521	For 11-13 FLHT/FLHR/FLHX/FLTR models	\$299.99
1020-1694	For 12-13 Softail, Dyna models (except FXSB/SE, 12 FLSTSE)	299.99
1020-1728	For 12-13 V-Rod models	299.99
1020-2023	For 07-13 XL	299.99
<b>ORIGINAL FUELPAK FOR 49 STATE USE</b>		
1020-0568	For 08-10 FLHT/FLHR/FLHX/FLTR models	299.99
1020-0361	For 02-07 FLHT/FLHR/FLHX/FLTR models	299.99
1020-2000	For 08-11 FXCW/C, 08-11 FLSTSB, 09 FXSTSSSE	299.99
1020-0538	For 07-11 FXST/B/C, 07-11 FLSTF	299.99
1020-0560	For 01-06 FXST, 01-11 FLST (except 07-11 FLSTF, 08-11 FLSTSB)	299.99
1020-2000	For 04-11 Dyna, 02-11 V-Rod and 09-12 XR1200 models	299.99
<b>FUELPAK CALIFORNIA A.R.B. EXEMPT</b>		
1020-0822	For 08 FLHR/FLHRC/FLHX/FLTR/FLHT/FLHTC/FLHTCU	\$299.99
1020-0819	For 07 FLHR/FLHRS/FLHRC/FLHX/FLTR/FLHT/FLHTC	299.99
1020-0818	For 07 FLSTN/FLSTC/FLSTSC/FXSTD, 08 FLSTN/FLSTC	299.99
1020-0820	For 07 FXD/FXDC/FXDB/FXDL/FXDWG, 08 FXD/FXDC	299.99
1020-0821	For 07 XL883/XL883L/XL883C/XL883R/XL883N/XL1200N/XL1200C/xH1200R/XL1200L, 08 XL883/XL883L/XL883C/XL1200N/XL1200L/XL1200C/XL1200R	299.99

**THROTTLEPAK™ THROTTLE MANAGEMENT SYSTEM**

- Brings back the quick throttle response lost in Throttle-By-Wire (TBW)
- One twist of the throttle and riders will notice the improved response and acceleration
- Works on any bike's configuration; stock, modified and any exhaust combination
- Possibly the easiest performance mod ever; installs in minutes, simply plug into factory connectors
- Made in the U.S.A.

PART #	DESCRIPTION	SUG. RETAIL
1020-1726	For all 08-13 H-D Throttle By Wire (TBW) models (Touring/CVO)	\$149.99



**DISCLAIMER:** NOT LEGAL FOR SALE OR USE IN CALIFORNIA ON ANY POLLUTION CONTROLLED MOTOR VEHICLES. SEE PAGE 399 FOR IMPORTANT EMISSION DEFINITIONS AND REGULATORY COMPLIANCE AND WARRANTY INFORMATION.

All part numbers in BLUE are new for 2017.



WINDSHIELDS  
& FAIRINGS

AUDIO &amp; VIDEO

SADDLEBAGS  
& LUGGAGESEATS &  
SISSY BARS

EXHAUST

FUEL/AIR  
SYSTEMS

ENGINE

TRANSMISSION  
& DRIVELINEGASKETS  
& SEALS

ELECTRICAL

LIGHTING

HANDLEBARS,  
CONTROLS  
& MIRRORS

CABLES

BRAKES

TANKS &  
OIL FILTERSDASHES  
& GAUGESFRAMES &  
SUSPENSIONFENDERS  
& LICENSE  
PLATE FRAMES

FOOTRESTS

WHEELS  
& AXLESHARDWARE,  
COVERS &  
GENERAL

### Fi2000 POWRPRO BLACK

- Requires no dyno tuning – plug it in and ride
- PowrPro Black analyzes, tunes and adjusts your air/fuel ratio for peak performance instantaneously
- Tunes acceleration fuel delivery in every gear for peak performance
- Works with stock or modified engines, air cleaners and exhaust systems
- Can fine-tune the non-acceleration air/fuel curves using the Bluetooth® app
- Can tune engine fuel delivery in specific ranges, check rpm, read fuel injector pulse width and duty cycle, and add or remove fuel in low- or mid-range rpm

PART #	DESCRIPTION	SUG. RETAIL
1020-2577	For 14-16 FLHT/FLHR/FLHX	\$499.95
1020-2565	For 10-13 FLHT/FLHR/FLTR/FLHX	499.95
1020-2562	For 08-09 FLHT/FLHR/FLTR/FLHX	499.95
1020-2576	For 10-13 FLHT Police models	499.95
1020-2575	For 08-09 FLHT Police models	499.95
1020-2558	For 07 FLHT/FLHR/FLTR/FLHX	499.95
1020-2553	For 06 FLHT/FLHR/FLTR/FLHX	499.95
1020-2551	For 95-05 FLHT/FLHR/FLTR/FLHX	499.95
1020-2574	For 12-13 FLST CVO	499.95
1020-2573	For 10-11 FLST CVO	499.95
1020-2607	For 16 FLS/FLST	499.95
1020-2567	For 12-15 FXS/FLS/FLST (except FXSB/SE, CVO)	499.95
1020-2564	For 08-11 FXST/FLST (except CVO models)	499.95
1020-2554	For 06 FXST/FLST	499.95
1020-2557	For 06-07 FXST/FLST, 08-09 FLT Police model	499.95
1020-2555	For 01-05 FXST/FLST and 04-05 Dyna Glide	499.95
1020-2639	For 16 FXDLS	499.95
1020-2561	For 08-11 FXCW/C	499.95
1020-2566	For 12-16 Dyna Glide (except 16 FXDLS)	499.95
1020-2560	For 08-11 Dyna Glide	499.95
1020-2556	For 07 Dyna Glide	499.95
1020-2559	For 06 Dyna Glide	499.95
1020-2568	For 12-16 V-Rod	499.95
1020-2563	For 08-11 VRSCA/B/R V-Rod	499.95
1020-2552	For 02-07 V-Rod	499.95
1020-2572	For 14-16 XL1200	499.95
1020-2571	For 14-16 XL883	499.95
1020-2569	For 07-13 XL (except XL1200V)	499.95
1020-2570	For 12-13 XL1200V	499.95

**DISCLAIMER:** NOT LEGAL FOR SALE OR USE IN CALIFORNIA ON ANY POLLUTION CONTROLLED MOTOR VEHICLES.  
SEE PAGE 399 FOR IMPORTANT EMISSION DEFINITIONS AND REGULATORY COMPLIANCE AND WARRANTY INFORMATION.

All part numbers in **BLUE** are new for 2017.

WINDSHIELDS & FAIRINGS

AUDIO & VIDEO

SADDLEBAGS & LUGGAGE

SEATS & SISSY BARS

EXHAUST

FUEL/AIR SYSTEMS

ENGINE

TRANSMISSION & DRIVELINE

GASKETS & SEALS

ELECTRICAL

LIGHTING

HANDLEBARS, CONTROLS & MIRRORS

CABLES

BRAKES

TANKS & OIL FILTERS

DASHES & GAUGES

FRAMES & SUSPENSION

FENDERS & LICENSE PLATE FRAMES

FOOTRESTS

WHEELS & AXLES

HARDWARE, COVERS & GENERAL

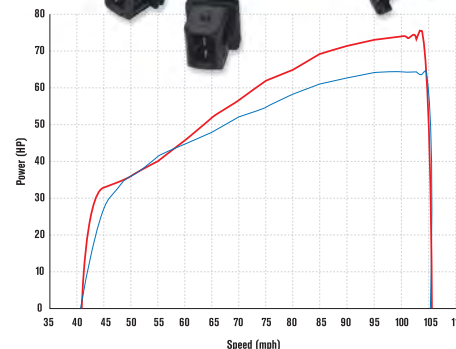

**COBRA:** Max Torque = 80.2 Max Power = 74.53  
**STOCK:** Max Torque = 73.1 Max Power = 64.37



**Fi2000R PLUG-IN FUEL PROCESSOR**

- Proven Fi2000R comes with leads that snap directly into the bike's injector bodies
- Standard open-loop design for 06 Dyna and all 07-08 models can use exhaust systems that do or do not have O<sub>2</sub> sensor bungs
- More advanced tuning for modified bikes
- Think of third tuning pot as an electronic main jet while thinking of the entire Fi2000R as a digital jet kit
- Full range of fuel adjustment (0-10 settings) across all rpm ranges
- Three easily identifiable lights: green – Fi2000R is adding more fuel to the air/fuel ratio approx. 14:1; green and yellow lights – these lights will be on in unison when throttle is open more quickly and air/fuel mixture is approx. 12.5:1; red – light comes on and stays on as long as the Fi2000R follows the fuel curve while adjusting to approx. 12.8:1 air/fuel ratio, which is where the engine will produce its best full-throttle power
- Step-by-step instructions
- Improves rideability by smoothing out the powerband and giving the bike more throttle response
- Corrects lean air/fuel mixture problems; eliminates overheating, hesitation on acceleration or an uneven cruising rpm
- Waterproof circuit board
- No fuel map adjustments or computer downloads required

PART #	DESCRIPTION	SUG. RETAIL
<b>STANDARD</b>		
1020-0561	For 08-09 FLHT, FLHR, FLTR, FLHX	\$249.95
1020-0304	For 07 FLHT, FLHR, FLTR, FLHX	249.95
1020-0204	For 06 FLHT, FLHR, FLTR, FLHX	249.95
1020-0093	For 95-05 FLHT, FLHR, FLTR, FLHX	249.95
1020-0301	For 07-11 FXST/FLST and 06-11 Dyna Glide	249.95
1020-0544	For 08-11 FXCW/FXCWC	249.95
1020-0206	For 06 FXST/FLST	249.95
1020-0095	For 01-05 FXST/FLST and 04-05 Dyna Glide	249.95

PART #	DESCRIPTION	SUG. RETAIL
<b>STANDARD (CONT)</b>		
1020-0306	For 07-11 XL (except XL1200V 12-13)	\$249.95
1020-0626	For 08-11 V-Rod	249.95
1020-0094	For 02-07 V-Rod	249.95
1020-0341	Repl. O <sub>2</sub> Sensor Eliminator kit	34.95
<b>CALIFORNIA A.R.B.</b>		
1020-0548	For 06 FLHT, FLHR, FLTR, FLHX	249.95
1020-0546	For 95-05 FLHT, FLHR, FLTR, FLHX	249.95
1020-0550	For 01-05 FXST/FLST	249.95
1020-0547	For 02-07 V-Rod	249.95



**Fi2000R O<sub>2</sub> STANDARD MODEL FUEL PROCESSORS**

- The Fi2000R O<sub>2</sub> digital fuel processor is designed to work with all H-D exhaust systems (stock or aftermarket) equipped with oxygen sensors in place (closed-loop design)
- Works much like a carburetor jet kit with adjustments similar to the air-mixture screw, the needle and clip positions and the main jet
- The Fi2000R increases horsepower and torque by optimizing stock lean air/fuel mixtures (helps cool the engine temps as well)
- Quick and simple installation with plug-and-ride technology with OEM-style connectors
- No confusing computer downloads to install
- No expensive dyno-testing required
- Pre-configured from the factory for your make and model, but easy to adjust should your specific application need it
- Improves overall rideability



**Low-Speed Screw**  
This control functions similar to the air mixture screw on a carburetor, controlling off-idle fuel demands and steady cruising.

**Mid-Speed Screw**  
This is the equivalent of the needle and clip position on a carburetor. Two increments correspond to dropping the clip on a needle one position. One increment is the same as adding a shim. This is where you get the proper fuel mixture under load and acceleration.

**High-Speed Screw**  
This is the electronic counterpart to your main jet. Each numbered increment is the same as going up one main jet size starting with the stock size at zero. This adjusts your fuel at full throttle.

PART #	DESCRIPTION	SUG. RETAIL
<b>STANDARD</b>		
1020-2126	For 14 FLHT, FLHR, FLHX	\$279.95
1020-1144	For 10-13 FLHT, FLHR, FLTR, FLHX	279.95
1020-0562	For 08-09 FLHT, FLHR, FLTR, FLHX	279.95
1020-0305	For 07 FLHT, FLHR, FLTR, FLHX	279.95
1020-1554	For 12-15 FXS/FLS/FLST (except FXSB/SE, CVO)	279.95
1020-2608	For 16 FLS/FLST	279.95
1020-0938	For 08-11 FXST/FLST	279.95
1020-0303	For 07 FXST/FLST	279.95
1020-0545	For 08-10 FXCW/FXCWC	279.95
1020-1552	For 12-16 Dyna Glide	279.95
1020-0937	For 08-11 Dyna Glide	279.95
1020-0302	For 07 Dyna Glide	279.95
1020-0314	For 06 Dyna Glide	279.95

PART #	DESCRIPTION	SUG. RETAIL
<b>STANDARD (CONT)</b>		
1020-2124	For 14-16 XL	\$279.95
1020-0307	For 07-13 XL	279.95
1020-1900	For 12-13 XL1200V	279.95
1020-1572	For 12-16 V-Rod	279.95
<b>CALIFORNIA/A.R.B.</b>		
1020-1145	For 10-11 FLHT	279.95
1020-0564	For 08 FLHT, FLHR, FLTR, FLHX	279.95
1020-1550	For 12 FXST/FLST	279.95
1020-0555	For 07 FLHT, FLHR, FLTR, FLHX	279.95
1020-1549	For 12 Dyna Glide	279.95
1020-0552	For 07-11 Dyna Glide	279.95
1020-0560	For 07-11 XL	279.95
1020-1573	For 12-13 V-Rod	279.95

**DISCLAIMER:** NOT LEGAL FOR SALE OR USE IN CALIFORNIA ON ANY POLLUTION CONTROLLED MOTOR VEHICLES. SEE PAGE 399 FOR IMPORTANT EMISSION DEFINITIONS AND REGULATORY COMPLIANCE AND WARRANTY INFORMATION.

All part numbers in BLUE are new for 2017.

WINDSHIELDS & FAIRINGS

AUDIO & VIDEO

SADDLEBAGS & LUGGAGE

SEATS & SISSY BARS

EXHAUST

FUEL/AIR SYSTEMS

ENGINE

TRANSMISSION & DRIVELINE

GASKETS & SEALS

ELECTRICAL

LIGHTING

HANDLEBARS, CONTROLS & MIRRORS

CABLES

BRAKES

TANKS & OIL FILTERS

DASHES & GAUGES

FRAMES & SUSPENSION

FENDERS & LICENSE PLATE FRAMES

FOOTRESTS

WHEELS & AXLES

HARDWARE, COVERS & GENERAL

# THUNDERMAX

## THUNDERMAX ECM WITH INTEGRAL AUTO TUNE SYSTEM

- ThunderMax ECM with Auto-Tune module mounts conveniently in place of the factory ECM and plugs in to the existing harness
- Utilizes wide-band O<sub>2</sub> sensors and works as a closed-loop control system to continuously self-adjust and properly tune the motorcycle's air/fuel ratio for all riding conditions
- Easy installation: replace the factory ECM, install new O<sub>2</sub> sensors and harness, load the correct map for your bike, and ride
- Includes ThunderMax ECM with Auto-Tune Module, plug-in harness and two wide-band sensors, TMax software and communication USB cable, Quick-Start Easy Install and Comprehensive User's Manual, technical support and free software and updates
- Hundreds of maps available to download for your bike (based on model, engine size, exhaust system air cleaner, pistons, cams, etc.) – load the map of your choice and the integral auto-tune will do the rest
- Improves throttle response, exhaust sound and driveability
- Does not require dyno tuning
- Rider can adjust idle speed, rev limit and speedometer calibration
- Adjustable front and rear cylinder AFR maps, ignition timing (spark) maps, and startup maps
- Works with all popular exhaust systems and is compatible with high-performance camshafts
- Supports turbo, nitrous and supercharger applications
- Software program allows live monitoring, recording and examination of diagnostic codes and datalogs including number of starts, engine temperature and rpm operation
- New maps, software, firmware updates, map analysis and tech support available online at no charge
- Made in the U.S.A.



**NOTE:** Because of possible clearance issues, some aftermarket exhaust systems may require modifications or relocation of their O<sub>2</sub> sensor port bungs.

PART #	DESCRIPTION	SUG. RETAIL
1020-2118 <sup>1</sup>	For 14-16 FLHT/FLHR/FLHX/FLTR models and 14-15 FLSTNSE models	\$989.95
1020-0836 <sup>1</sup>	For 08-13 FLHT/FLHR/FLHX/FLTR models and 09-13 H-D FL Trike	989.95
1020-2360 <sup>1</sup>	For 12-15 FXS/FLS/FLST models, 12-17 FXD/FLD/FXDWG models (except FXDLS) and 14-17 XL models	899.95
1020-1848	For 11 FXS/FLST models	899.95
1020-1851	For 01-10 FXST/FLST, 02-07 FLHT/FLHR/FLTR/FLHX, 07-09 XL	899.95
1020-2361	For 08-10 FXCW/C, 04-11 FXD/FXDWG, 09 SE Softail, 10-13 XL models and 08-12 XR1200/X (includes mini USB pigtail)	919.95
1020-1853 <sup>1</sup>	For 02-15 V-Rod models	919.95
1020-2382	For 15-17 XG500/750 models	899.95
1022-0039	Repl. 18mm oxygen sensor (ea.)	117.95

<sup>1</sup> Will require the use of an exhaust system with 18mm sensor bungs or headpipes must be modified to accept 18mm sensors.

## THUNDERMAX 50 ECM

- California ARB-compliant complete replacement engine-management system for Delphi®-equipped EFI model Harleys
- Integral auto-tune system utilizes wide-band O<sub>2</sub> sensors and works as a closed-loop control system to continuously self-adjust and properly tune the motorcycle's air/fuel ratio in all conditions
- Easy installation – replace the factory ECM, install new O<sub>2</sub> sensors and harness, and ride
- Improves throttle response and increases horsepower and torque
- Maintains excellent fuel economy
- Includes Thundermax 50 ECM, plug-in harness, two wide-band O<sub>2</sub> sensors, software, communication USB cable, comprehensive user's manual, full technical support and free software updates
- Software allows examination of vehicle diagnostic codes
- 01-06 models will require the exhaust system to be equipped with or modified for O<sub>2</sub> sensor bungs
- Made in the U.S.A.



**NOTE:** Because of possible clearance issues, some aftermarket exhaust systems may require modifications or relocation of their O<sub>2</sub> sensor port bungs.

C.A.R.B. EO #s D-644 01-06, K-001 08, K-001-1 09, K-001-2 10, K-001-3 08 NEW FAM.

PART #	DESCRIPTION	SUG. RETAIL
1020-1132	For 06 FXST and Touring models (88" engine only)	\$899.95
1020-0837	For 01-05 Softail, 02-05 Touring models (88" engine only)	899.95

## THUNDERMAX PIGTAIL HARNESS

- Allows a second port for the communication cable connection to the ThunderMax
- It is installed to the bike's wiring harness at the 36-pin ECM connector (connection requires harness plug disassembly; two terminated wires are inserted into two unused ports in the 36-pin connector, and a ground wire added)
- Handy for motorcycle models with tight clearances around the ECM such as Dyna, Softail Rocker and 02-05 V-Rod models
- Made in the U.S.A.

1022-0059

1020-1855



**NOTE:** PART # 1022-0059 requires ThunderMax ECM with serial number 114000 or higher (produced beginning August 2008). Will not work on previous model ThunderMax PART #232661 TBW unit.

**NOTE:** PART # 1020-1855 requires ThunderMax ECM with Mini USB communication port (beginning November 2012). Will not work on previous model ThunderMax ECM or PART #1020-0836 (Touring TBW units).

PART #	DESCRIPTION	SUG. RETAIL
1022-0059	ThunderMax pigtail harness for V-Rod PART #1020-1853, Gen II PART #s 1020-0323, 1020-1279, 1020-1311 and AutoTune repl. module PART #1020-0322	\$18.95
1020-1855	ThunderMax Mini USB pigtail for remote access to modules PART #s 1020-1851, 1020-1852 and 1020-2361	18.95

**DISCLAIMER:** NOT LEGAL FOR SALE OR USE IN CALIFORNIA ON ANY POLLUTION CONTROLLED MOTOR VEHICLES. SEE PAGE 399 FOR IMPORTANT EMISSION DEFINITIONS AND REGULATORY COMPLIANCE AND WARRANTY INFORMATION.

All part numbers in **BLUE** are new for 2017.

**Daytona Twin Tec**

WINDSHIELDS & FAIRINGS

AUDIO & VIDEO

SADDLEBAGS & LUGGAGE

SEATS & SISSY BARS

EXHAUST

FUEL/AIR SYSTEMS

ENGINE

TRANSMISSION & DRIVELINE

GASKETS & SEALS

ELECTRICAL

LIGHTING

HANDLEBARS, CONTROLS & MIRRORS

CABLES

BRAKES

TANKS & OIL FILTERS

DASHES & GAUGES

FRAMES & SUSPENSION

FENDERS & LICENSE PLATE FRAMES

FOOTRESTS

WHEELS & AXLES

HARDWARE, COVERS & GENERAL

**TWIN SCAN COMPLETE KIT**

- Includes both a Twin Scan II ABS unit for 01-16 models with J1850 data bus and a Twin Scan 3 ABS unit for 11-15 Softail/Dyna models with CAN data bus
- Uses Windows® 7-8-10 PCs for display
- Reads and clears diagnostic trouble codes from ECM, BCM, ABS, speedo and tach
- Real-time display of engine data on PC instrument panel-type display
- Built-in data logging; stores up to one hour of data
- Triggers when trouble code is set and shows data before and after data is set
- Includes two analog inputs with 0-20V or ±200V range; Twin Scan 3 features two-channel scopemeter capability for waveform display
- Analog inputs can also be used for air/flow ratio (AFR)
- Complete kit includes WEGO IIID Interface for tuning capability with both Twin Scan versions, two Bosch LSU 4.2 wide-band oxygen sensors, two 18 x 1.5mm weld nuts, two 18 x 1.5 mm hex socket plugs, USB cable, the Twin Scan 3 Probe Kit for use with the scopemeter feature of the Twin Scan 3 ABS, and software (on CD ROM)
- Made in the U.S.A.



PART #	DESCRIPTION	SUG. RETAIL
3807-0251	For 11-16 models w/ CANbus systems, 01-16 36-pin Delphi fuel-injected, 04-06 carbureted models w/ 12-pin module	\$1,312.00

**TCFI AUTO-TUNING FUEL INJECTION KITS**

- Offers real-time and continuous auto-tuning with monitoring, control and override capability
- Utilizes high end Alpha-N fuel control to eliminate any dependence on manifold pressure; unaffected by long duration and high overlap camshafts
- Programmable user outputs for functions such as shift light, nitrous activation and electric shifter
- Supports all sensors including theft and security module
- User-friendly PC Link software with 3-D graphics and easy spreadsheet editing capabilities for quick cell block changes
- Built in data logging that helps you diagnose real world problems
- Easy to install by simply replacing stock ECM and O2 sensors with those included in kit; detailed instructions included
- Kit includes TCFI plug in fuel injection controller, USB interface for PC, software, WEGO IIID dual channel wide band exhaust gas oxygen sensor interface, two Bosch LSU 4.2 wide band exhaust oxygen sensors and two 18 x 1.5mm weld nuts for exhaust pipes
- See page 599 for replacement weld nuts and socket plugs
- Made in the U.S.A.



1020-2383

PART #	DESCRIPTION	SUG. RETAIL
1020-2384	For 14-15 FLHT/FLHR/FLHX/FLTRX models	\$885.00
1020-2383	For 08-13 FLHT/FLHR/FLHX/FLTR models	885.00
1021-0008	For 12-15 Dyna/Softail	885.00
1021-0007	For 01-11 Twin Cam (except 11 Softail and 08-11 Touring models)	885.00
1020-1895	For 02-13 V-Rod	885.00
1020-1896	For 07-13 Sportster	885.00
<b>REPLACEMENT COMPONENTS FOR TCFI INJECTION TUNERS</b>		
1022-0008	Repl. Bosch brand WEGO II oxygen sensor (sold each)	109.00

**BLUETOOTH® INTERFACE ADAPTER FOR TCFI INJECTION TUNERS**

- Allows wireless connectivity for TCFI and VRFI series engine tuners/controllers
- Requires use of a laptop or PC with Bluetooth capability; compatible with Windows 7, 8 or 10
- Made in the U.S.A.



PART #	DESCRIPTION	SUG. RETAIL
1020-2252	Bluetooth interface adapter	\$94.00

**DISCLAIMER:** NOT LEGAL FOR SALE OR USE IN CALIFORNIA ON ANY POLLUTION CONTROLLED MOTOR VEHICLES. SEE PAGE 399 FOR IMPORTANT EMISSION DEFINITIONS AND REGULATORY COMPLIANCE AND WARRANTY INFORMATION.

All part numbers in BLUE are new for 2017.

WINDSHIELDS  
& FAIRINGS

AUDIO &amp; VIDEO

SADDLEBAGS  
& LUGGAGESEATS &  
SISSY BARS

EXHAUST

FUEL/AIR  
SYSTEMS

ENGINE

TRANSMISSION  
& DRIVELINEGASKETS  
& SEALS

ELECTRICAL

LIGHTING

HANDLEBARS,  
CONTROLS  
& MIRRORS

CABLES

BRAKES

TANKS &  
OIL FILTERSDASHES  
& GAUGESFRAMES &  
SUSPENSIONFENDERS  
& LICENSE  
PLATE FRAMES

FOOTRESTS

WHEELS  
& AXLESHARDWARE,  
COVERS &  
GENERAL**Daytona Twin Tec****TWIN TUNER FUEL-INJECTION CONTROLLER**

- Allows easy adjustments to OEM Delphi fuel-injection systems to improve performance and match the requirements of performance parts
- Mode and up/down pushbutton switches make fuel trim adjustments in the rpm and throttle position ranges required by most applications; fuel trim value is displayed on a bright daylight-readable LED display
- Advanced mode (using optional USB Interface PART #2101-0075 and PC Link Tuner software) allows precise fuel adjustments and independent adjustments to the front and rear cylinders
- May be compatible with other controller maps
- Easy plug-in installation and setup
- Compact size – only 4" L x 2" W x .5" H
- Compatible with Twin Scan II+ Tuning Aid – install the Twin Scan II+ and ride the bike, then copy the air/fuel ratio corrections calculated by the Twin Scan II+ into the PC Link Tuner software
- Made in the U.S.A.



PART #	DESCRIPTION	SUG. RETAIL
<b>1020-1813</b>	For 12-13 Softail and Dyna	<b>\$264.00</b>
<b>1020-0358</b>	For 01-11 Big Twin (except 11 Softail, 08-11 Touring models) and 08-09 Buell XB, 1125R	<b>237.00</b>
<b>1020-0939</b>	For 08-13 FLHT, FLHR, FLTR and FLHX models	<b>237.00</b>
<b>1020-0951</b>	For 11 Softail, 07-13 XL	<b>237.00</b>
<b>1020-0834</b>	For 03-07 Buell	<b>237.00</b>

**Daytona Twin Tec****TWIN TUNER II**

- Twin Tuner II has all the features of the original Twin Tuner and includes ignition timing control capability
- Easily adjusts the OEM Delphi fuel-injection and ignition to match the requirements of performance parts including high-compression pistons/heads, camshafts, free-flowing exhausts, and low-restriction air filters – add 30% or subtract 20% fuel and retard spark timing up to 10°
- You can use the mode and up/down pushbutton switches to make fuel trim adjustments in the rpm and throttle position ranges required by most applications; the fuel trim value is displayed on a bright daylight readable LED display
- The Twin Tuner also has an advanced mode, using the optional USB Interface and PC Link Tuner software to make precise fuel adjustments and allows independent adjustments to the front and rear cylinders
- May be compatible with other controller maps
- Easy plug-in installation and setup, with no splicing, cutting, crimping or bulky interconnections
- Compact size – only 4" L x 2" W x 1/2" H
- Compatible with Twin Scan II+ Tuning Aid – install the Twin Scan II+ and ride the bike, then copy the air/fuel ratio corrections calculated by the Twin Scan II+ into the PC Link Tuner software

1020-0948



PART #	DESCRIPTION	SUG. RETAIL
<b>1020-1814</b>	For 12-13 Softail and Dyna (except FXSB/SE)	<b>\$322.00</b>
<b>1020-0948</b>	For 01-11 Big Twin and 07-13 XL (except 08-11 Touring models)	<b>270.00</b>
<b>1020-0949</b>	For 08-13 FLHT, FLHR, FLTR and FLHX	<b>322.00</b>
<b>1020-1328</b>	For 02-13 V-Rod	<b>270.00</b>

**DYNATEK**  
*dyn performance electronics***FI CONTROLLER**

- Plug-in module offers three user-selectable base fuel curves designed to improve engine operation on fuel-injected models
- Can be configured to suit a wide variety of modifications
- Adjustments are made via three potentiometers that adjust the fuel curve in the proper ranges for the application
- Fuel mixture can be enriched or leaned as required
- Uses factory connectors for easy installation – there is no PC required for tuning or adjusting the fuel curves
- No modifications to the stock ECU
- Removing the FI controller returns vehicle to factory configuration
- Made in the U.S.A.

**DISCLAIMER:** LEGAL IN CALIFORNIA ONLY FOR RACING VEHICLES WHICH MAY NEVER BE USED, OR REGISTERED OR LICENSED FOR USE, UPON A HIGHWAY.

PART #	DESCRIPTION	SUG. RETAIL
<b>1020-0190</b>	For 97-98 FLHT, FLHR, FLTR models	<b>\$249.95</b>
<b>1020-0191</b>	For 99-01 FLHT, FLHR, FLTR models	<b>249.95</b>
<b>1020-0192</b>	For 02-05 FLHT, FLHR, FLTR models	<b>249.95</b>
<b>1020-1224</b>	For 08 FLHT, FLHR, FLHX, FLTR models	<b>259.95</b>
<b>1020-0503</b>	For 06 FLHT, FLHR, FLHX, FLTR models	<b>249.95</b>

**DISCLAIMER:** NOT LEGAL FOR SALE OR USE IN CALIFORNIA ON ANY POLLUTION CONTROLLED MOTOR VEHICLES.  
SEE PAGE 399 FOR IMPORTANT EMISSION DEFINITIONS AND REGULATORY COMPLIANCE AND WARRANTY INFORMATION.

All part numbers in **BLUE** are new for 2017.

WINDSHIELDS & FAIRINGS

AUDIO & VIDEO

SADDLEBAGS & LUGGAGE

SEATS & SISSY BARS

EXHAUST

FUEL/AIR SYSTEMS

ENGINE

TRANSMISSION & DRIVELINE

GASKETS & SEALS

ELECTRICAL

LIGHTING

HANDLEBARS, CONTROLS & MIRRORS

CABLES

BRAKES

TANKS & OIL FILTERS

DASHES & GAUGES

FRAMES & SUSPENSION

FENDERS & LICENSE PLATE FRAMES

FOOTRESTS

WHEELS & AXLES

HARDWARE, COVERS & GENERAL



1020-2342



1020-1828



2130-0131



1861-0810



**RCX-CELERATOR CLOSED-LOOP FUEL MANAGEMENT SYSTEMS**

- Self-learning computer automatically adjusts the fuel/air mixture as you ride and compensates for changes in engine load conditions
- Automatically recalibrates for modifications to the exhaust system and air intake – mufflers, headers and air cleaner
- Maximizes performance and engine efficiency while decreasing emissions and fuel consumption
- Quick-connect plugs for easy installation
- No downloads or adjustments required
- No dyno tuning required
- Work in conjunction with factory and race tuner downloads
- Quicker throttle response on TBW models
- Made in the U.S.A.

PART #	DESCRIPTION	SUG. RETAIL
<b>STANDARD</b>		
1020-2471	For 14-15 FLHT/FLHR/FLHX/FLTRX models with oval TPS Connector, uses factory O <sub>2</sub> sensors (6-pin)	\$470.95
1020-2342	For 08-13 FLHT/FLHR/FLTR/FLHX with oval TPS connector, uses factory O <sub>2</sub> connector (6-pin)	450.95
1020-1836	For 12-13 Softail, 12-13 Dyna with round TPS connector (except FXSB/SE), uses factory O <sub>2</sub> connector (3-pin)	400.95
1020-1837	For 12-13 VRSC with flat TPS connector, uses factory O <sub>2</sub> connector (3-pin)	400.95
1020-1828	For 02-05 FLHT/FLHR/FLTR/FLHX, 01-05 FXST, 04-05 Dyna, 02-07 V-Rod with flat TPS connector, comes with one O <sub>2</sub> sensor (3-pin)	452.95
1020-1831	For 07-11 Softail (except 11-13 CVO), 06-11 Dyna, 07 FLHT/FLHR/FLTR/FLHX, 10 CVO with round TPS connector, uses factory O <sub>2</sub> sensors (3-pin)	400.95
1020-1829	For 06 Softail, 06 FLHT/FLHR/FLTR/FLHX with round TPS connector, comes with one O <sub>2</sub> sensor (3-pin)	452.95
1020-1830	For 95-01 Magneti Marelli models with flat TPS connector, comes with one O <sub>2</sub> sensor (3-pin)	452.95
1020-1833	For 07-13 XL with flat TPS connector, uses factory O <sub>2</sub> connector (3-pin)	400.95
1020-1834	For 08-11 VRSC with flat TPS connector, uses factory O <sub>2</sub> connector (3-pin)	400.95
<b>REPLACEMENT PARTS</b>		
2130-0131	Repl. 18MM O <sub>2</sub> sensor (ea.)	105.95
1861-0810	Repl. 18MM O <sub>2</sub> sensor bung (ea.)	16.95



**STEALTH SUPERTUNER**

- Capable of flash-tuning Delphi fuel injected models with a new tune that matches any Stage 1 combination
- Unlimited free updates allow for re-tuning at any time
- Plug-and-play design for easy use
- No wiring or parts to install
- Eliminates Throttle-by-Wire lag
- Reads and clears diagnostic trouble codes for easy troubleshooting

**DISCLAIMER:** LEGAL IN CALIFORNIA ONLY FOR RACING VEHICLES WHICH MAY NEVER BE USED, OR REGISTERED OR LICENSED FOR USE, UPON A HIGHWAY.



1020-2473



1020-2474

PART #	DESCRIPTION	SUG. RETAIL
1020-2473	For 04-12 Dyna, 01-11 Softail, 07-13 Sportster and 01-13 Touring models w/ J1850 4-pin connector	\$257.95
1020-2474	For 13-15 Dyna, 12-15 Softail, 14-15 Sportster and 14-15 Touring models w/ CAN 6-pin connector	286.95

**DISCLAIMER:** NOT LEGAL FOR SALE OR USE IN CALIFORNIA ON ANY POLLUTION CONTROLLED MOTOR VEHICLES. SEE PAGE 399 FOR IMPORTANT EMISSION DEFINITIONS AND REGULATORY COMPLIANCE AND WARRANTY INFORMATION.

All part numbers in BLUE are new for 2017.

WINDSHIELDS & FAIRINGS

AUDIO & VIDEO

SADDLEBAGS & LUGGAGE

SEATS & SISSY BARS

EXHAUST

FUEL/AIR SYSTEMS

ENGINE

TRANSMISSION & DRIVELINE

GASKETS & SEALS

ELECTRICAL

LIGHTING

HANDLEBARS, CONTROLS & MIRRORS

CABLES

BRAKES

TANKS & OIL FILTERS

DASHES & GAUGES

FRAMES & SUSPENSION

FENDERS & LICENSE PLATE FRAMES

FOOTRESTS

WHEELS & AXLES

HARDWARE, COVERS & GENERAL

1020-2033



**Daytona Twin Tec**

**FI-TO-CARBURETOR CONVERSION KIT**

- Allows most Big Twin and XL models with Delphi EFI to be converted to a carb fuel system
- Uses existing wiring harness with no modifications needed
- All functions of the turn signal/security module continue to function normally
- Includes required software and detailed instructions
- Made in the U.S.A.

**NOTE:** Requires the separate purchase of USB interface PART #2101-0075.  
**NOTE:** Requires the separate purchase of a Pingel fuel injection-to-carb tank fitting kit PART #0705-0031.

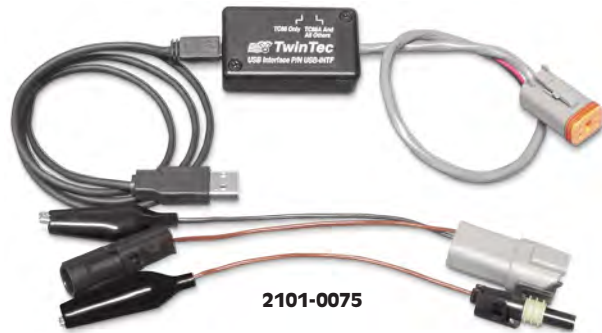

2101-0075

PART #	DESCRIPTION	SUG. RETAIL
1020-2033	For 01-13 Big Twin and 07-13 XL models w/ 36-pin connector (except 11-13 Softail and 12-13 Dyna)	\$544.00
2101-0075	USB interface kit	94.00

1020-1717



1020-1714



**ADJUSTABLE O<sub>2</sub> ENRICHMENT DEVICES**

- Enrichment devices are intended to give riders the proper fuel mixture when adding performance mufflers, pipes and high flow air filter upgrades
- Adjustable version allows external adjustment of the air-fuel ratio in closed-loop mode
- Cheaper than other fuel management programmers or auto tuners
- Reduces engine temperature 20-30 degrees
- Recommended for models with high-flow air intakes and exhaust
- PART #1020-1715 includes AFR display
- Made in the U.S.A.

1020-1716



1020-1715



PART #	DESCRIPTION	SUG. RETAIL
1020-1717	For 10-16 Touring models, all 12-17 Softail, Dyna and V-Rod models	\$129.95
1020-1714	For all 08-09 XB9/XB12 Buell models w/ stock ECM	84.95
1020-1716	For 06-11 Dyna, 07-11 Softail, 07-13 XL and 07-08 Touring models	129.95
1020-1715	For 06-11 Dyna, 07-11 Softail, 07-13 XL and 07-08 Touring models (adjustable)	195.95

**O<sub>2</sub> ENRICHMENT DEVICE**

- Reduce your engine's temperature 20 to 30 degrees
- Installs in a few minutes; simply plug in between the oxygen sensors and the OEM wiring harness
- Recommended for models with high-flow air intakes and exhausts
- Sold in pairs
- Made in the U.S.A.



1020-1151



PART #	DESCRIPTION	SUG. RETAIL
1020-1296	For 10-16 Touring models and 12-17 Softail/Dyna models (all)	\$129.95
1020-1295	For 09 Touring models (all)	119.95
1020-1151	For 07-08 Touring models and all 07-11 Big Twin Race (except 08-11 Touring and H-D FL Trikes)	119.95
1020-0796	For 06 Dyna and all 07-11 models (except 08-12 Touring and H-D FL Trikes)	88.95
1020-1152	For 07-13 XL and 09-12 XR 1200	119.95

**DISCLAIMER:** NOT LEGAL FOR SALE OR USE IN CALIFORNIA ON ANY POLLUTION CONTROLLED MOTOR VEHICLES.  
 SEE PAGE 399 FOR IMPORTANT EMISSION DEFINITIONS AND REGULATORY COMPLIANCE AND WARRANTY INFORMATION.

All part numbers in **BLUE** are new for 2017.

WINDSHIELDS & FAIRINGS

AUDIO & VIDEO

SADDLEBAGS & LUGGAGE

SEATS & SISSY BARS

EXHAUST

FUEL/AIR SYSTEMS

ENGINE

TRANSMISSION & DRIVELINE

GASKETS & SEALS

ELECTRICAL

LIGHTING

HANDLEBARS, CONTROLS & MIRRORS

CABLES

BRAKES

TANKS & OIL FILTERS

DASHES & GAUGES

FRAMES & SUSPENSION

FENDERS & LICENSE PLATE FRAMES

FOOTRESTS

WHEELS & AXLES

HARDWARE, COVERS & GENERAL



**70MM INDUCTION KITS**

- Include a 70mm S&S Throttle Hog throttle body and all components needed for installation on the 143" engine
- S&S Stealth air cleaner included, use stock 99-07 cover or any of the S&S Stealth covers (available separately)



PART #	DESCRIPTION	SUG. RETAIL	PART #	DESCRIPTION	SUG. RETAIL
<b>1021-0011</b>	For 06-07 Touring models	<b>\$1,599.95</b>	<b>1021-0012</b>	For 02-05 Touring/Dyna models	<b>\$1,599.95</b>



**SINGLE-BORE THROTTLE BODIES AND MANIFOLDS**

- Designed for riders seeking the greatest possible performance gains from their fuel-injected engines
- For maximum tunability and performance gains an S&S Variable Fuel-Injection (VFI) module is recommended (sold separately), but any compatible, programmable module with enough capability and tuning range can be used
- Components must be purchased separately to complete a Single-Bore EFI assembly
- Made in the U.S.A.

NOTE: Appropriate air cleaner kit must be ordered separately, see page 642



PART #	DESCRIPTION	SUG. RETAIL
<b>THROTTLE BODIES</b>		
<b>1022-0029</b>	52mm for stock 01-05 EFI Big Twin and aftermarket models (Delphi-style)	<b>\$723.95</b>
<b>1022-0081</b>	58mm for 01-05 EFI Big Twin and aftermarket models (Delphi-style)	<b>723.95</b>
<b>1022-0082</b>	58mm for 06-16 Big Twin and aftermarket models (Delphi-style) (except 16 Softail, and 08-16 Touring models)	<b>642.95</b>
<b>MANIFOLDS</b>		
<b>1050-0151</b>	52mm for 80", 88", 89", 95", 96", 103" and 106" motors	<b>159.95</b>
<b>1050-0243</b>	58mm for 124" 01-05 Big Twin w/ 5.013" cylinder length	<b>159.95</b>
<b>1050-0261</b>	58mm for 96", 103" and 106" 06-16 Big Twins w/ stock or S&S heads w/ 4.937" cylinder length	<b>159.95</b>

**ELLIPTICAL HIGH-TORQUE THROTTLE BODY AND 58" MANIFOLD KIT**

- Replaces OEM throttle body and manifold
- Provides quicker throttle response through elliptical intake track design
- Wider manifold to fit most taller engines
- Compatible with all OEM electrical components, including throttle position sensors, air control motors and fuel injectors
- Electronic components not included (MAP sensor, fuel rails and injectors)
- Made in the U.S.A.

NOTE: Manifold may require custom fitting based on intake port location.



PART #	DESCRIPTION	SUG. RETAIL
<b>1022-0048</b>	For 06-10 Delphi EFI Twin Cam models (except 08-10 FLHT/FLHR/FLHX/FLTR and H-D FL trikes)	<b>\$778.95</b>

**DISCLAIMER:** NOT LEGAL FOR SALE OR USE IN CALIFORNIA ON ANY POLLUTION CONTROLLED MOTOR VEHICLES. SEE PAGE 399 FOR IMPORTANT EMISSION DEFINITIONS AND REGULATORY COMPLIANCE AND WARRANTY INFORMATION.

All part numbers in **BLUE** are new for 2017.



WINDSHIELDS & FAIRINGS

AUDIO & VIDEO

SADDLEBAGS & LUGGAGE

SEATS & SISSY BARS

EXHAUST

FUEL/AIR SYSTEMS

ENGINE

TRANSMISSION & DRIVELINE

GASKETS & SEALS

ELECTRICAL

LIGHTING

HANDLEBARS, CONTROLS & MIRRORS

CABLES

BRAKES

TANKS & OIL FILTERS

DASHES & GAUGES

FRAMES & SUSPENSION

FENDERS & LICENSE PLATE FRAMES

FOOTRESTS

WHEELS & AXLES

HARDWARE, COVERS & GENERAL



**MAXFLOW™ THROTTLE BODIES**

- Large plenum design maximizes mid- and high-rpm power
- Specifically designed for larger cubic inch motors that require substantial airflow
- Fully machined and ported internally for unparalleled flow
- Feature a natural finish with split shaft design and stainless steel spring
- Equipped with a sealed double roller bearing for smooth throttle operation
- Brass throttle blade and shaft resist deflection, which helps maintain throttle position accuracy
- Completely replaces OEM throttle body and manifold; fully compatible with OEM components
- Made in the U.S.A.

NOTE: Size given for throttle bodies is measured at the butterfly.

PART #	THROTTLE BODY	MANIFOLD	INTAKE RUNNER	SUG. RETAIL
<b>FOR 06-17 TWIN CAM W/ DELPHI EFI (EXCEPT 17 FXDLS, 16-17 SOFTAIL, 08-17 FLHT/FLHR/FLHX/FLTR AND H-D FL TRIKES)</b>				
1022-0067	55mm	58mm	1.800"	\$785.95
<b>FOR 01-05 TWIN CAM W/DELPHI EFI</b>				
1022-0066	55mm	58mm	1.800"	785.95

1022-0067



1022-0066



**BIG BORE THROTTLE BODIES**

- Flow bench-tested and dyno-proven to deliver increased airflow, horsepower and torque
- Fully machined and ported internally for unparalleled flow
- Feature a natural finish with split shaft design and stainless steel spring
- Equipped with a sealed double roller bearing for smooth throttle operation
- Brass throttle blade resists deflection, which helps maintain throttle position accuracy
- Completely replaces OEM throttle body and manifold; fully compatible with OEM components
- Made in the U.S.A.

NOTE: Size given for throttle bodies is measured at the butterfly.

PART #	DESCRIPTION	INTAKE RUNNER	SUG. RETAIL	PART #	DESCRIPTION	INTAKE RUNNER	SUG. RETAIL
<b>FOR 06-17 TWIN CAM W/ DELPHI EFI (EXCEPT 17 FXDLS, 16-17 SOFTAIL, 08-17 FLHT/FLHR/FLHX/FLTR AND H-D FL TRIKES)</b>				<b>FOR 01-05 TWIN CAM WITH DELPHI EFI</b>			
1022-0159	51mm	1.66"	\$694.95	1022-0157	51mm	1.66"	\$694.95
1022-0160	55mm	1.66"	694.95	1022-0158	55mm	1.66"	694.95
1022-0064	51mm	1.710"	694.95	1022-0062	51mm	1.710"	694.95
1022-0065	55mm	1.800"	694.95	1022-0063	55mm	1.800"	694.95

1022-0064



1022-0062



**SERVO HARNESS COVER**

- Hides the servo motor harness on the side of the throttle body
- Easy to install, no need to remove air cleaner
- Strong ABS polymer construction in chrome and black
- Designed to blend in with the engine and pushrod tubes

PART #	DESCRIPTION	SUG. RETAIL
1015-0144	For 09-16 FLHT/FLHR/FLTR/FLHX AND H-D TRIKE	\$49.95



**DISCLAIMER:** NOT LEGAL FOR SALE OR USE IN CALIFORNIA ON ANY POLLUTION CONTROLLED MOTOR VEHICLES. SEE PAGE 399 FOR IMPORTANT EMISSION DEFINITIONS AND REGULATORY COMPLIANCE AND WARRANTY INFORMATION. All part numbers in BLUE are new for 2017.



**KURYAKYN**

**THROTTLE SERVO MOTOR COVERS**

- Quick, easy upgrade to the stock throttle servo motor
- Simple installation
- Available with a chrome or gloss black finish

FOR 17 FXDLS, 16-17 SOFTAIL, 08-16 FLHT/FLHR/FLTR/FLHX AND H-D FL TRIKES, 11-12 FLTSE, 14-15 FLSTNSE AND 13-14 FXSBSE

PART #	DESCRIPTION	SUG. RETAIL	PART #	DESCRIPTION	SUG. RETAIL
<b>CHROME</b>			<b>GLOSS BLACK</b>		
1015-0114	For all Kuryakyn air cleaners	\$79.99	1015-0128	For all Kuryakyn air cleaners	\$79.99
1015-0113	For all Screamin' Eagle Stage 1 air cleaners	79.99	1015-0127	For all Screamin' Eagle Stage 1 air cleaners	79.99



**THROTTLE SERVO COVER**

- Simple, slim and attractive 2-piece design
- Covers throttle by wire servos
- For use with Performance Machine air cleaners only
- Available in chrome and black anodized finishes
- Made in the U.S.A.

PART #	DESCRIPTION	SUG. RETAIL
<b>FOR 17 FXDLS, 16-17 SOFTAIL, 08-16 FLHT/FLHR/FLTR/FLHX AND H-D TRIKE</b>		
1015-0123	Black anodized	\$69.95
1015-0124	Chrome	69.95

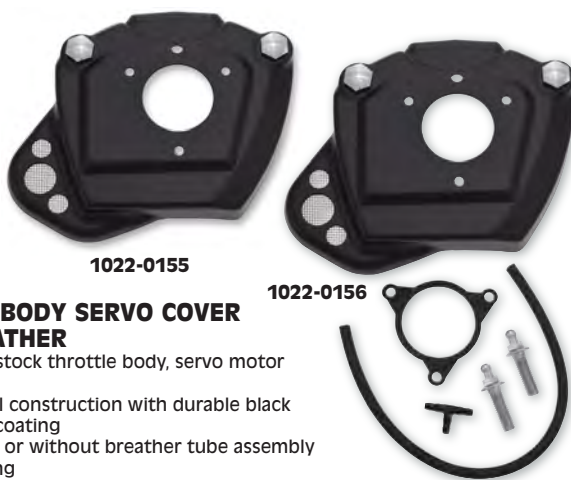

**THROTTLE BODY SERVO COVER WITH BREATHER**

- Fits over the stock throttle body, servo motor and wiring
- Stamped steel construction with durable black satin powdercoating
- Available with or without breather tube assembly
- Patent pending

PART #	DESCRIPTION	SUG. RETAIL
1022-0155	For 17 FXDLS, 16-17 Softail, 14-16 FLHT/FLHR/FLHX/FLTR (w/o breather tube assembly)	\$79.95
1022-0156	For 08-13 FLHT/FLHR/FLHX/FLTR (w/ breather tube assembly)	91.95



**KURYAKYN**

**THROTTLE BODY COVER**

- Mounts behind the air cleaner assembly
- Cleans up the look and adds a chrome finish

PART #	DESCRIPTION	SUG. RETAIL
1015-0122	For 02-07 FLHT/FLHR/FLTR/FLHX, 01-15 FLST/FXST, 04-16 Dyna w/ EFI and Kuryakyn air cleaner (except Hypercharger or Twin Velocity/Twin Velocity Plus), Arlen Ness Big Sucker Stage I or II air cleaner or Screamin' Eagle Stage I air cleaner and Heavy Breather	\$49.99



**INJECTI-COVERS™**

- Constructed from 16-gauge cold-rolled steel, polished, then chrome-plated
- Great looking covers hide the OEM throttle body
- Offer a true custom look
- Made in the U.S.A.

NOTE: Covers may not fit with all styles of breather kits and support brackets. Check clearance before mounting.

PART #	DESCRIPTION	SUG. RETAIL
1022-0002	For 01-15 FXST/FLST, 02-13 FLT w/ Screamin' Eagle air filter	\$59.95



**DISCLAIMER:** NOT LEGAL FOR SALE OR USE IN CALIFORNIA ON ANY POLLUTION CONTROLLED MOTOR VEHICLES. SEE PAGE 399 FOR IMPORTANT EMISSION DEFINITIONS AND REGULATORY COMPLIANCE AND WARRANTY INFORMATION.

All part numbers in BLUE are new for 2017.

WINDSHIELDS & FAIRINGS

AUDIO & VIDEO

SADDLEBAGS & LUGGAGE

SEATS & SISSY BARS

EXHAUST

FUEL/AIR SYSTEMS

ENGINE

TRANSMISSION & DRIVELINE

GASKETS & SEALS

ELECTRICAL

LIGHTING

HANDLEBARS, CONTROLS & MIRRORS

CABLES

BRAKES

TANKS & OIL FILTERS

DASHES & GAUGES

FRAMES & SUSPENSION

FENDERS & LICENSE PLATE FRAMES

FOOTRESTS

WHEELS & AXLES

HARDWARE, COVERS & GENERAL

WINDSHIELDS & FAIRINGS

AUDIO & VIDEO

SADDLEBAGS & LUGGAGE

SEATS & SISSY BARS

EXHAUST

FUEL/AIR SYSTEMS

ENGINE

TRANSMISSION & DRIVELINE

GASKETS & SEALS

ELECTRICAL

LIGHTING

HANDLEBARS, CONTROLS & MIRRORS

CABLES

BRAKES

TANKS & OIL FILTERS

DASHES & GAUGES

FRAMES & SUSPENSION

FENDERS & LICENSE PLATE FRAMES

FOOTRESTS

WHEELS & AXLES

HARDWARE, COVERS & GENERAL



**O<sub>2</sub> SENSORS**

- Precision manufactured with a ceramic body made of stabilized zirconium dioxide, surface coated with gas-permeable platinum electrodes and a porous ceramic to help prevent erosion due to contamination and particulates in the exhaust gases
- Slow reading oxygen sensors can cause a drop in fuel economy of 10-15%, excessive exhaust emissions and poor drivability
- Life expectancy of an average oxygen sensor in a properly tuned engine is typically 30,000-50,000 miles
- Narrow band O<sub>2</sub> sensors available in 12.5", 16.25" and 22.25" overall lengths
- Replacement Wide Band O<sub>2</sub> sensor for aftermarket ignition tuners also available; overall length is 30.25"
- All sensors meet or exceed OE specifications
- Made in the U.S.A.



PART #	DESCRIPTION	SUG. RETAIL
<b>18MM WIDE BAND O<sub>2</sub> SENSORS FOR AFTERMARKET TUNERS</b>		
1861-0887	30.25" length	\$119.95

PART #	DESCRIPTION	LOCATION	SUG. RETAIL
<b>18MM NARROW BAND O<sub>2</sub> SENSORS</b>			
1861-0884	For 07-08 Touring, 07-13 Sportster models	Front and rear (12.5")	\$59.95
1861-0884	For 09 Touring models	Rear (12.5")	\$9.95
1861-0885	For 07-11 Softail, 06-11 Dyna models	Front and rear (16.25")	\$9.95
1861-0885	For 09 Touring, 09 V-Rod models	Front (16.25")	\$9.95
1861-0886	For 08 V-Rod models	Front and rear (22.25")	\$9.95
1861-0886	For 09 V-Rod models	Rear (22.25")	\$9.95

PART #	DESCRIPTION	SUG. RETAIL
<b>12MM NARROW BAND O<sub>2</sub> SENSORS</b>		
1861-1106	Black 4 wire connector, 29" length	\$79.95
1861-1107	Gray 4 wire connector, 29" length	\$9.95
<b>O<sub>2</sub> SENSORS ADAPTOR</b>		
1861-1108	12mm/18mm	\$2.95

**18MM O<sub>2</sub> SENSORS**

- Precision-made for outstanding performance
- Meets or exceeds OEM standards
- Easy fit with no modifications needed
- Extra high-temperature dual-shield end
- Sold each
- Made in the U.S.A.



PART #	DESCRIPTION	SUG. RETAIL
1861-0977	7.5" length; repl. OEM #27719-07	\$64.95
1861-0978	11.5" length; repl. OEM #27683-07	\$4.95
1861-0979	17.5" length; repl. OEM #27703-08	\$4.95

**FUEL REGULATOR HOUSING**

- Anodized black housing is CNC machined from billet aluminum
- Replaces the plastic OEM housing
- Made in the U.S.A.



PART #	DESCRIPTION	SUG. RETAIL
1009-0025	For 01-07 FXST/FLST, 02-07 FLHT/FLHX/FLHR/FLTR models; repl. OEM #62373-01	\$48.95



**FUEL PRESSURE REGULATOR**

- 62 psi Delphi regulator
- Designed for greater fuel delivery
- Engineered for a direct fit in most OEM fuel-injection applications
- Made in the U.S.A.



PART #	DESCRIPTION	SUG. RETAIL
1009-0013	For 02-07 FLT/FLHT/FLHR/FLTR, 01-07 FXST/FLST, 02-17 V-Rod models, repl. OEM # 27408-01	\$128.95



**WIDE-BAND BOSCH O<sub>2</sub> SENSOR**

- 18mm sensor for use with exhaust systems or air/fuel ratio meters
- Sold each



PART #	DESCRIPTION	SUG. RETAIL
1861-0521	Bosch O <sub>2</sub> sensor	\$99.95



**OXYGEN SENSOR ACTIVE INTAKE AND EXHAUST ELIMINATOR KIT**

- Oxygen Sensor Eliminator Kits allow air/fuel ratio changes for racing applications
- Active Intake and Exhaust Eliminator Kit is used to avoid setting a diagnostic trouble code when installing some aftermarket air filters and exhaust that require the removal of original equipment active systems; for off-road racing use only
- Made in the U.S.A.



PART #	DESCRIPTION	SUG. RETAIL
1020-1479	For late-model European spec models w/ active intake and exhaust	\$30.00



**INDUCTION MODULE ASSEMBLY O-RING KIT**

- Kit contains fuel fitting O-rings
- Made in the U.S.A.



PART #	DESCRIPTION	SUG. RETAIL
DS-174988	For 95-01 FLT, FLHT, FLHR fuel-injected models; repl. OEM #17043-95	\$17.95



**FUEL PUMP COMPONENTS**

- All parts are OEM replacement
- Check OEM part # for the correct application
- Sold each



PART #	DESCRIPTION	SUG. RETAIL
<b>FUEL PRESSURE REGULATOR</b>		
0706-0237	For 08-17 FLHT/FLTR/FLHR models, 04-17 FXD/FXDWG/FLD models, 08-17 FXS/FXST/FLS/FLST models 07-17 XL883/1200 models; repl. OEM #61015-04A	\$28.95
0706-0236	For 02-07 FLT/FLHT/FLTR/FLHR models, 01-07 FXST/FLST models, 02-17 V-Rod models; repl. OEM #27408-01	\$6.95
<b>REGULATOR HOUSING</b>		
1009-0014	For 01-07 Softail and 02-07 Touring models; repl. OEM #62373-01	\$3.95

**DISCLAIMER:** NOT LEGAL FOR SALE OR USE IN CALIFORNIA ON ANY POLLUTION CONTROLLED MOTOR VEHICLES. SEE PAGE 399 FOR IMPORTANT EMISSION DEFINITIONS AND REGULATORY COMPLIANCE AND WARRANTY INFORMATION.

All part numbers in BLUE are new for 2017.

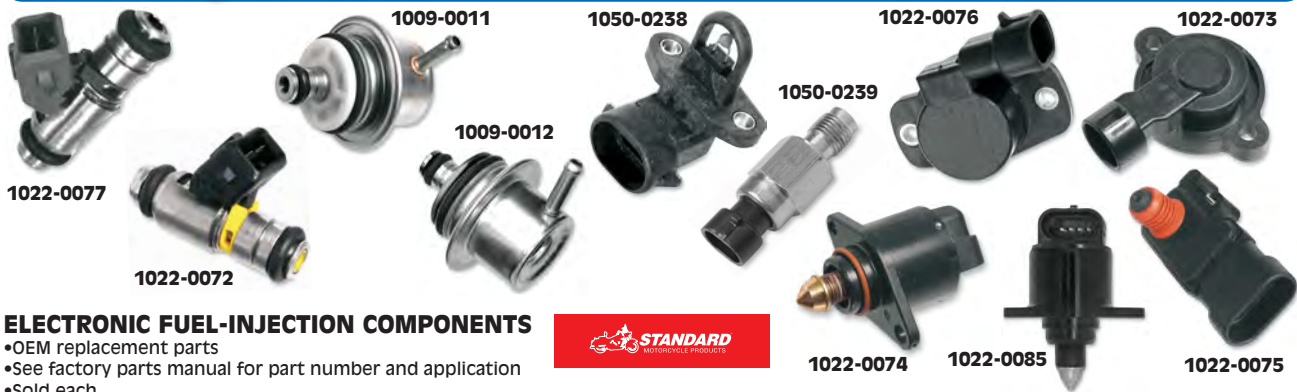

WINDSHIELDS & FAIRINGS

AUDIO & VIDEO

SADDLEBAGS & LUGGAGE

SEATS & Sissy BARS

EXHAUST

FUEL/AIR SYSTEMS

ENGINE

TRANSMISSION & DRIVELINE

GASKETS & SEALS

ELECTRICAL

LIGHTING

HANDLEBARS, CONTROLS & MIRRORS

CABLES

BRAKES

TANKS & OIL FILTERS

DASHES & GAUGES

FRAMES & SUSPENSION

FENDERS & LICENSE PLATE FRAMES

FOOTRESTS

WHEELS & AXLES

HARDWARE, COVERS & GENERAL

**ELECTRONIC FUEL-INJECTION COMPONENTS**

- OEM replacement parts
- See factory parts manual for part number and application
- Sold each



PART #	DESCRIPTION	SUG. RETAIL
<b>INJECTORS</b>		
1022-0077	For 01-05 FXST/FLST, 02-05 FLT and 04-05 Dyna models (4.04 gm/sec) (ea.); repl. OEM #27609-01	\$188.95
1022-0072	For 01-05 FXST/FLST, 02-05 FLT and 04-05 Dyna models (high flow, 5.9 gm/sec) (ea.); repl. OEM #27609-01	229.95
<b>FUEL REGULATORS</b>		
1009-0011	For 95-99 (350 kPa); repl. OEM #27219-95	94.95
1009-0012	For 95-99 (300 kPa); repl. OEM #27219-95	77.95
<b>AIR TEMPERATURE SENSOR</b>		
1050-0238	For 95-05; repl. OEM #27270-95	45.95
<b>ENGINE TEMPERATURE SENSOR</b>		
1050-0239	For 99-17; repl. OEM #32446-99	41.95

PART #	DESCRIPTION	SUG. RETAIL
<b>THROTTLE POSITION SENSORS</b>		
1022-0076	For 01-05 FXST/FLST/FXSTD, 02-05 FLT/FLHT and 04-05 Dyna models; repl. OEM #27629-01	\$71.95
1022-0073	For 06-17 Dyna (except 16-17 FXDLS), 06-15 FXST/FLST and 06-07 FLHT models; repl. OEM #27659-06	35.95
<b>IDLE AIR CONTROL MODULES</b>		
1022-0074	For 06-17 Dyna (except 16-17 FXDLS), 06-15 FXST/FLST and 06-07 FLHT models; repl. OEM #27658-06	52.95
1022-0085	For 01-05 FXST/FLST, 02-05 FLHT/FLHR/FLTR, 04-05 Dyna and 02-10 VRSC models; repl. OEM #27628-01	58.95
<b>MAP SENSOR WITH SEAL</b>		
1022-0075	For 99-10 fuel-injected Big Twin models (except 08-10 Dressers), 00-06 Big Twin and 04-06 XL carb models; repl. OEM #32316-99	72.95



**ELECTRONIC FUEL-INJECTION COMPONENTS**

- Quality OEM replacements and upgrades available as listed
- Sold each

PART #	DESCRIPTION	CONNECTOR TYPE	FLOW RATE, GRAMS PER SECOND	SUG. RETAIL
<b>INJECTORS</b>				
1022-0120	For 06-17 Twin Cam (except ETC models) including SE 50, 58 and 62mm cable drive throttle bodies. Injectors provide 33% more fuel than the OE injectors through 4 spray holes with a dual pattern; 13°/6°. Recommended for performance engine combinations making over 100 rear wheel horsepower	EV-6 USCAR	5.3	\$99.95
1022-0112	For 06-17 Twin Cam 96 and 103 (except 08-17 Dressers, 16-17 FXDLS, 16-17 Softails, 11-12 FLSTFSE, 13 FXSBSE models) w/ OEM 46mm throttle body (updated 25° angle cone with 6 spray-hole nozzle ends, supersedes OEM #27625-06); repl. OEM #27709-06/A	EV-6 USCAR	3.91	99.95
1022-0113	For 01-17 Twin Cam w/ OEM 46mm, OEM 50mm, Screamin' Eagle 43mm throttle body (4 spray holes) for stock to mild performance engines; repl. OEM #27609-01B	EV-1 Minitimer square	4.3	99.95
1022-0114	For 06-17 Twin Cam 96 and 103 (except 08-17 Dressers, 16-17 FXDLS, 16-17 Softails, 11-12 FLSTFSE, 13 FXSBSE models), Screamin' Eagle 50, 58 and 62mm throttle bodies (25% more fuel than OE, 3 spray holes), for race applications only with over 100hp at rear wheel; repl. OEM #27654-06	EV-6 USCAR	4.9	99.95
1022-0115	For 08-17 Dressers, 16-17 FXDLS, 16-17 Softails, includes Screamin' Eagle 58mm throttle body and high flow oval-port intake manifold (4 spray holes, 23% over OEM for race applications only with over 100hp at rear wheel); repl. OEM #27654-06	EV-1 Minitimer square	5.3	99.95
1022-0116	For 06-17 Twin Cam (except 08-17 Dressers, 16-17 FXDLS, 16-17 Softails, 11-12 FLSTFSE, 13 FXSBSE models) including Screamin' Eagle 58 and 62mm high flow throttle bodies (59% more fuel than OE), for race applications only with over 120hp at rear wheel; repl. OEM #27400004	EV-6 USCAR	6.2	99.95
1022-0118	For 07-17 XL for stock to mild performance engines; repl. OEM #27706-07/A	EV-1 Minitimer square	3.8+	99.95
1022-0119	For 01-17 VRSC for stock to mild performance engines; repl. OEM #27665-01/A	EV-1 Minitimer square	5.1+	119.95
1022-0161	For Destroyer VRSCX for stock high performance engines	EV-1 Minitimer square	7.6+	99.95
<b>THROTTLE POSITION SENSORS</b>				
1022-0121	For 06-07 FLHT, 06-15 FXST/FLST, 06-17 Dyna (except 16-17 FXDLS); repl. OEM #27659-06	-	-	69.95
1022-0123	For 02-05 FLT/FLHT, 01-05 FXSTI/FLSTI/FXSTDI, 04-05 Dyna; repl. OEM #27629-01	-	-	69.95
<b>IDLE AIR CONTROL MODULE</b>				
1022-0122	For 06-07 FLHT, 06-15 FXST/FLST, 06-17 Dyna (except 16-17 FXDLS); repl. OEM #27658-06	-	-	49.95
<b>MAP SENSOR WITH SEAL</b>				
1022-0124	For 99-10 fuel-injected Big Twin models (except 08-10 Dressers), 00-06 Big Twin and 04-06 XL carb models; repl. OEM #32316-99	-	-	69.95
1022-0162	For 08-16 touring, 16-17 FXDLS, 16-17 Softails and 07-17 XL fuel-injected models; repl. OEM #32319-07/A	-	-	79.95
<b>INJECTOR ADAPTER (EA.)</b>				
1022-0180	Adapts EV6 plug to fit EV1 injector	-	-	19.95

**DISCLAIMER:** NOT LEGAL FOR SALE OR USE IN CALIFORNIA ON ANY POLLUTION CONTROLLED MOTOR VEHICLES. SEE PAGE 399 FOR IMPORTANT EMISSION DEFINITIONS AND REGULATORY COMPLIANCE AND WARRANTY INFORMATION.

All part numbers in BLUE are new for 2017.

WINDSHIELDS & FAIRINGS

AUDIO & VIDEO

SADDLEBAGS & LUGGAGE

SEATS & SISSY BARS

EXHAUST

FUEL/AIR SYSTEMS

ENGINE

TRANSMISSION & DRIVELINE

GASKETS & SEALS

ELECTRICAL

LIGHTING

HANDLEBARS, CONTROLS & MIRRORS

CABLES

BRAKES

TANKS & OIL FILTERS

DASHES & GAUGES

FRAMES & SUSPENSION

FENDERS & LICENSE PLATE FRAMES

FOOTRESTS

WHEELS & AXLES

HARDWARE, COVERS & GENERAL



**ELECTRONIC FUEL-INJECTION COMPONENTS**

- High-quality OEM replacements
- Sold each



PART #	DESCRIPTION	SUG. RETAIL
<b>INJECTORS</b>		
DS289284	For 01-05 FXST/FLST, 02-05 FLT and 04-05 Dyna models (4.04 gm/sec) (ea.); repl. OEM #27609-01	\$178.95
1022-0009	For 01-05 FXST/FLST, 02-05 FLT and 04-05 Dyna models (high flow, 5.9 gm/sec) (ea.); repl. OEM #27609-01	214.95
<b>FUEL REGULATORS</b>		
1009-0005	For 95-99 (350 kPa), (50 PSI); repl. OEM #27219-95	89.95
DS-289143	For 95-99 (300 kPa), (43 PSI); repl. OEM #27219-95	74.95
<b>AIR TEMPERATURE SENSOR</b>		
DS-289144	For 95-05; repl. OEM #27270-95	43.95
<b>ENGINE TEMPERATURE SENSOR</b>		
DS289285	For 99-17; repl. OEM #32446-99	38.95
<b>BAROMETRIC PRESSURE SWITCH</b>		
DS189001	For 95-98 (100 kPa); repl. OEM #32424-95	64.95

PART #	DESCRIPTION	SUG. RETAIL
<b>THROTTLE POSITION SENSORS</b>		
2103-1002	For 01-05 FXST/FLST/FXSTD, 02-05 FLT/FLHT and 04-05 Dyna models; repl. OEM #27629-01	\$69.95
1022-0021	For 06-17 Dyna (except 16-17 FXDLS), 06-15 FXST/FLST and 06-07 FLHT models; repl. OEM #27659-06	34.95
<b>IDLE AIR CONTROL MODULES</b>		
1022-0022	For 06-17 Dyna (except 16-17 FXDLS), 06-15 FXST/FLST and 06-07 FLHT models; repl. OEM #27658-06	50.95
1022-0084	For 01-05 FXST/FLST, 02-05 FLHT/FLHR/FLTR, 04-05 Dyna and 02-10 VRSC models; repl. OEM #27628-01	56.95
<b>MAP SENSOR WITH SEAL</b>		
1050-0039	For 99-10 fuel-injected Big Twin models (except 08-10 Dressers), 00-06 Big Twin and 04-06 XL carb models; repl. OEM #32316-99	70.95

**HIGH PERFORMANCE FUEL INJECTORS**



- Ten different flow rates
- Made using the latest injector technology
- Sold in matched sets
- Detailed test report included with each set
- Made in the U.S.A.



PART #	DESCRIPTION	SUG. RETAIL
<b>FOR 01-05 TWIN CAM MODELS W/ DELPHI EFI</b>		
1022-0127	4.5 grams per second at 58 psi, 25° spray angle	\$222.00
1022-0128	5.4 grams per second at 58 psi, 25° spray angle	250.00
1022-0129	6.2 grams per second at 58 psi, 25° spray angle	250.00
1022-0130	7.1 grams per second at 58 psi, 25° spray angle	250.00
1022-0131	7.8 grams per second at 58 psi, 25° spray angle	273.00
1022-0132	8.5 grams per second at 58 psi, 25° spray angle	273.00
1022-0133	9.2 grams per second at 58 psi, 18° spray angle	273.00
1022-0134	9.9 grams per second at 58 psi, 18° spray angle	330.00
1022-0135	10.6 grams per second at 58 psi, 18° spray angle	330.00
<b>FOR 06-17 TWIN CAM MODELS W/ CABLE THROTTLE CONTROL (EXCEPT V-ROD AND SPORTSTER)</b>		
1022-0136	3.9 grams per second at 58 psi, 25° spray angle	222.00
1022-0137	5.4 grams per second at 58 psi, 25° spray angle	250.00
1022-0138	6.2 grams per second at 58 psi, 25° spray angle	250.00
1022-0139	7.1 grams per second at 58 psi, 25° spray angle	250.00

PART #	DESCRIPTION	SUG. RETAIL
<b>FOR 06-17 TWIN CAM MODELS W/ CABLE THROTTLE CONTROL (EXCEPT V-ROD AND SPORTSTER) (CONT)</b>		
1022-0140	7.8 grams per second at 58 psi, 25° spray angle	\$273.00
1022-0141	8.5 grams per second at 58 psi, 25° spray angle	273.00
1022-0142	9.2 grams per second at 58 psi, 25° spray angle	273.00
1022-0143	9.9 grams per second at 58 psi, 25° spray angle	330.00
1022-0144	10.6 grams per second at 58 psi, 25° spray angle	330.00
<b>FOR 16-17 FXDLS, 16-17 SOFTTAILS, 08-16 DRESSERS MODELS W/ ELECTRONIC THROTTLE CONTROL</b>		
1022-0145	5.4 grams per second at 58 psi, 18° spray angle	250.00
1022-0146	6.2 grams per second at 58 psi, 18° spray angle	250.00
1022-0147	7.1 grams per second at 58 psi, 18° spray angle	250.00
1022-0148	7.8 grams per second at 58 psi, 18° spray angle	273.00
1022-0149	8.5 grams per second at 58 psi, 18° spray angle	273.00
1022-0150	9.2 grams per second at 58 psi, 18° spray angle	273.00
1022-0151	9.9 grams per second at 58 psi, 18° spray angle	330.00
1022-0152	10.6 grams per second at 58 psi, 18° spray angle	330.00

**HI FLOW FUEL RAIL AND HARNESS**

- Fuel rail is machined from T-6061 billet aluminum, then black anodized
- Allows use of short body Pico injectors
- Accepts multiple injector sizes for high-performance applications
- Harness features OEM-style connectors for easy installation
- Made in the U.S.A.



PART #	DESCRIPTION	SUG. RETAIL
1022-0125	For 06-07 FLT/FLHT/FLTR/FLHR, 06-15 FXD/FXDWC, 02-15 FXST/FLST models	\$159.95

**HI FLOW FUEL RAIL AND INJECTORS**

- Fuel rail is machined from T-6061 billet aluminum, then black anodized
- High-flow injectors flow 8.69 grams per second
- Will support over 200 horsepower
- Made in the U.S.A.



PART #	DESCRIPTION	SUG. RETAIL
1022-0105	For 02-17 V-Rod	\$649.95

**HI FLOW FUEL INJECTORS**

- A must for any high-performance motor
- Flow 8.69 grams per second; provide more flexibility in tuning the motor
- Sold in pairs
- Made in the U.S.A.



PART #	DESCRIPTION	SUG. RETAIL
1022-0106	For 01-05 Softail, 02-05/08-13 FL Touring, 04-05 Dyna	\$379.95



**"YELLOW BAND" FUEL INJECTORS**

- 43% increase in flow over stock injectors
- 6.2 gps (grams per second)
- Recommended for "Big Inch" engines with large plenums (120 hp or greater)
- Sold in pairs
- Made in the U.S.A.

PART #	DESCRIPTION	SUG. RETAIL
1022-0083	For 02-05 FLHT/FLHR/FLHX/FLTR, 01-05 FLST/FXST and 04-05 FXD	\$285.95

**FUEL INJECTOR**

- Meets OE stock specifications
- Sold each
- EV-6 USCAR connector

PART #	DESCRIPTION	SUG. RETAIL
1022-0181	For 06-17 Twin Cam w/ cable throttle control; repl. OEM #27709-06/A	\$86.95



**DISCLAIMER:** NOT LEGAL FOR SALE OR USE IN CALIFORNIA ON ANY POLLUTION CONTROLLED MOTOR VEHICLES.

SEE PAGE 399 FOR IMPORTANT EMISSION DEFINITIONS AND REGULATORY COMPLIANCE AND WARRANTY INFORMATION.

All part numbers in BLUE are new for 2017.

1001-0046



DS-0419



1001-0018



**SUPER E AND G SHORTY CARBURETOR KITS**

- Each carb kit includes a natural finish S&S Super E or Super G gas carburetor (unless noted) with updated fuel delivery pots and idle screw, S&S teardrop air cleaner assembly, manifold (unless noted), mounting hardware, fuel line, clamps, overflow line, one extra intermediate jet and two main jets, VOES tubing (when applicable), installation and jetting instructions
- Super E has a 1.875" throat at the butterfly and a 1.5625" venturi and is recommended for use on Big Twin or Sportster engines up to 100-cubic-inch
- Super G has a 2.0625" throat at the butterfly and a 1.75" venturi and is recommended for use on 90-cubic-inch and larger high-performance and modified engines
- Super G is not recommended for smaller, lower compression engines
- If there is a doubt as to which carburetor to use, we suggest the 1.875" Super E
- Individual carburetors also available
- Made in the U.S.A.

**NOTE:** S&S Super E & G carburetors require the use of a two-cable, pull open/pull close throttle assembly; S&S kits are compatible with stock cables except as noted.

DESCRIPTION	SUPER E CARB KIT	SUG. RETAIL	SUPER G CARB KIT	SUG. RETAIL
<b>FOR BIG TWIN MODELS (INCLUDES MANIFOLD)</b>				
For 99-05 Twin Cam	DS-0452	\$584.95	DS-0453	\$599.95
For 99-06 Twin Cam, T143 Twin Cam style engine (incl. Stealth air cleaner)	-	-	1001-0046 <sup>1</sup>	1199.95
For 92-99 Evolution Big Twin	DS-0419	584.95	DS-0434	599.95
For 84-91 Evolution Big Twin	DS-0407	584.95	DS-0427	599.95
<b>FOR BIG TWIN MODELS (NO MANIFOLD)</b>				
For 92-99 Evolution Big Twin	DS-0442	514.95	-	-
For 84-91 Evolution Big Twin	DS-0440	514.95	-	-
<b>FOR XL MODELS (INCLUDES MANIFOLD)</b>				
For 04-06 XL	1001-0018	584.95	-	-
For 91-03 XL	DS-0409	584.95	-	-
For 86-90 XL	DS-0408	584.95	-	-

<sup>1</sup> Does not include air cleaner cover. Stock 99-06 cover or any S&S Stealth style cover can be used (sold separately).

PART #	DESCRIPTION	SUG. RETAIL
<b>REPLACEMENT COMPONENTS</b>		
1002-0025	Super E carburetor only, natural	\$349.95
1001-0043	Super E carburetor only, black	399.95
1002-0026	Super G carburetor only, natural	369.95
1001-0044	Super G carburetor only, black	419.95
1014-0040	Repl. Slasher-style air cleaner cover, chrome	143.95
DS-289404	Repl. S&S air cleaner cover, chrome	143.95
1011-1721	Repl. air cleaner element for E & G carbs	20.95
DS-289405	Repl. air cleaner screws (10-pk.)	.95 (ea.)
1011-0324	Repl. breather hose for 93-06 Big Twin and 91-03 XL	5.95
1014-0133	Repl. S&S air cleaner cover for E & G carb, black	121.95
1011-0325	Breather screw seals (silicone-coated steel washer), .520" (10-pk.)	1.25 (ea.)
1011-0326	Breather screw seals (silicone-coated steel washer), .380" (10-pk.)	1.25 (ea.)

**CRUISE CONTROL ADAPTER KIT**

- Super Shorty carbs can easily be installed on motorcycles equipped with stock H-D cruise control
- Includes all parts and instructions needed to complete installation
- Made in the U.S.A.

PART #	DESCRIPTION	SUG. RETAIL
1003-0022	For 98-06 Big Twin	\$67.95



**DISCLAIMER:** NOT LEGAL FOR SALE OR USE IN CALIFORNIA ON ANY POLLUTION CONTROLLED MOTOR VEHICLES. SEE PAGE 399 FOR IMPORTANT EMISSION DEFINITIONS AND REGULATORY COMPLIANCE AND WARRANTY INFORMATION.

All part numbers in **BLUE** are new for 2017.

- WINDSHIELDS & FAIRINGS
- AUDIO & VIDEO
- SADDLEBAGS & LUGGAGE
- SEATS & MISSY BARS
- EXHAUST

**FUEL/AIR SYSTEMS**

- ENGINE
- TRANSMISSION & DRIVELINE
- GASKETS & SEALS
- ELECTRICAL

**LIGHTING**

**HANDLEBARS, CONTROLS & MIRRORS**

**CABLES**

**BRAKES**

**TANKS & OIL FILTERS**

**DASHES & GAUGES**

**FRAMES & SUSPENSION**

**FENDERS & LICENSE PLATE FRAMES**

**FOOTRESTS**

**WHEELS & AXLES**

**HARDWARE, COVERS & GENERAL**

WINDSHIELDS & FAIRINGS

AUDIO & VIDEO

SADDLEBAGS & LUGGAGE

SEATS & SISSY BARS

EXHAUST

FUEL/AIR SYSTEMS

ENGINE

TRANSMISSION & DRIVELINE

GASKETS & SEALS

ELECTRICAL

LIGHTING

HANDLEBARS, CONTROLS & MIRRORS

CABLES

BRAKES

TANKS & OIL FILTERS

DASHES & GAUGES

FRAMES & SUSPENSION

FENDERS & LICENSE PLATE FRAMES

FOOTRESTS

WHEELS & AXLES

HARDWARE, COVERS & GENERAL



**HSR42 AND HSR45 SMOOTHBORE CARBURETOR KITS**

- Kits include the 42mm/45mm smoothbore carb in a natural finish
- Easier, faster installation using stock CV throttle cables
- Excellent throttle response, more power, improved acceleration and better gas mileage
- Order fewer part numbers to cover more applications
- HSR smoothbore carbs offer excellent throttle response and control
- Well made for years of dependable service
- See pages 634-635 for additional main and pilot jets
- Installation instructions and hardware included
- Made in Japan

NOTE: Kits are not for use on models with cruise controls.

**42MM/45MM EASY KITS**

- Accepts the original H-D intake manifold, choke cable, air cleaner and throttle cables
- Keep the stock look of your bike
- Recommend the use of a high-flow air filter designed for the stock CV carb
- Made in Japan

**42/45MM TOTAL KITS**

- Includes performance intake manifold, rubber flange, 42mm or 45mm carb, high-flow K&N filter, air cleaner cover, breather kit and hardware
- 84-89 models require the use of 90-95 Big Twin-style cables
- Made in Japan



**EASY KITS**

PART #	DESCRIPTION	SUG. RETAIL
<b>42MM</b>		
42-18	For 99-06 Twin Cam and 90-99 Evolution Big Twin (not for use with stock air cleaner; requires a hi-perf air cleaner; use stock air cleaner cover; may be used with a Screamin' Eagle air filter kit)	\$398.95
42-7	For 90-99 Evolution Big Twin (include chrome air cleaner cover)	459.95
42-10	For 94-03 XL 1200 models (include special backing plate and hardware; use stock oval air cleaner cover and high-flow filter)	459.95
42-11	For 94-06 XL 1200 models and 94-02 Buell must use aftermarket air filter (include air filter adapter)	438.95
<b>45MM</b>		
1002-0030	For 99-06 Twin Cam and 90-99 Evolution Big Twin; requires use of Screamin' Eagle manifold (use stock air cleaner cover; may be used with a Screamin' Eagle air filter kit)	459.95

**TOTAL KITS**

PART #	DESCRIPTION	SUG. RETAIL	PART #	DESCRIPTION	SUG. RETAIL
<b>42MM CARB KITS</b>					
42-8 <sup>1</sup>	For 84-89 Evolution Big Twin (except 84-88 FLT)	\$598.95	<b>45MM CARB KITS</b>		
42-19	For 99-06 Twin Cam	658.95	45-2X <sup>1</sup>	For 84-99 Evolution Big Twin (except 84-88 FLT)	\$678.95
			45-4X	For 99-06 Twin Cam	678.95

<sup>1</sup> 84-89 models will require 90-95 Big Twin intake manifold flanges and seals (sold separately).

**HSR42 AND HSR45 SMOOTHBORE CARBURETORS**

- For the high-performance engine builder who needs a carb for specific custom applications
- Available in standard or highly-polished finishes
- HSR smoothbore carbs offer excellent throttle response and control
- Well made for years of dependable service
- See pages 634-635 for additional main and pilot jets
- Made in Japan

NOTE: Choke cable included, except for the TM42-6, which uses stock choke cable from CV-type carb.

NOTE: Airbox adapter HS42/001-K must be ordered separately.

NOTE: Kits are not for use on models with cruise controls.

PART #	DESCRIPTION	SUG. RETAIL	PART #	DESCRIPTION	SUG. RETAIL	PART #	DESCRIPTION	SUG. RETAIL
TM42-6	42mm carb, standard finish	\$374.95	TM45-2	45mm carb, standard finish	\$438.95	HS42012-250	2 1/2" filter element	\$84.95
TM42-6P	42mm carb, polished finish	508.95	TM45-2P	45mm carb, polished finish	578.95	HS42/012-300	3" filter element	84.95



**REPLACEMENT FILTER ELEMENT**

- Replacement 2 1/2" or 3" filter element for HSR42/45/48 carburetor
- Made in Japan

**HSR48 SMOOTHBORE CARBURETORS**

- These high-performance carbs are ideal for realizing the maximum potential from custom and race engines
- Available in standard or highly-polished finishes
- Recommended for engines over 1200ci or larger
- Includes rubber mounting flange with 78mm bolt hole centers, choke cable and four different main jets
- Uses stock H-D throttle cables
- HSR smoothbore carbs offer excellent throttle response and control
- Well made for years of dependable service
- See pages 634-635 for additional main and pilot jets
- For race and custom applications only
- Made in Japan

PART #	DESCRIPTION	SUG. RETAIL
48-2P	48mm carb, polished finish	\$638.95
482X	48mm carb, standard finish	459.95



**DISCLAIMER:** NOT LEGAL FOR SALE OR USE IN CALIFORNIA ON ANY POLLUTION CONTROLLED MOTOR VEHICLES. SEE PAGE 399 FOR IMPORTANT EMISSION DEFINITIONS AND REGULATORY COMPLIANCE AND WARRANTY INFORMATION.

All part numbers in BLUE are new for 2017.

WINDSHIELDS & FAIRINGS

AUDIO & VIDEO

SADDLEBAGS & LUGGAGE

SEATS & SISSY BARS

EXHAUST

FUEL/AIR SYSTEMS

ENGINE

TRANSMISSION & DRIVELINE

GASKETS & SEALS

ELECTRICAL

LIGHTING

HANDLEBARS, CONTROLS & MIRRORS

CABLES

BRAKES

TANKS & OIL FILTERS

DASHES & GAUGES

FRAMES & SUSPENSION

FENDERS & LICENSE PLATE FRAMES

FOOTRESTS

WHEELS & AXLES

HARDWARE, COVERS & GENERAL

DS-289086



**SUB66**

**38MM CARB KIT**

- Designed for easy installation and easy tuning capabilities
- Kit includes 38mm VM Mikuni carb, rubber manifold adapter flange, hose clamps, single throttle cable, two differently-sized main jets and a chrome reusable K&N air cleaner

**NOTE:** Does not include manifold.

PART #	DESCRIPTION	SUG. RETAIL
DS-289086	38mm Mikuni carb kit for 84-89 H-D Evo models w/ single-cable throttle control	\$256.95
0650-1125	Repl. throttle cable	21.95

DS-289078



DS-289079



**BENDIX CARBURETOR**

- High-performance Bendix carburetor is a bolt-on replacement that doesn't require any extra fittings or linkage connections
- Most offer adjustable high-speed jets; all provide improved acceleration and easier, quicker starts
- Made in the U.S.A.

**NOTE:** All Bendix carbs may be used for other applications, provided correct cables are used.

PART #	DESCRIPTION	SUG. RETAIL
DS-289078	40mm high-performance carb w/ adjustable main jet, standard finish, for all 84-89 Big Twin and 86-87 XL w/ dual-throttle cable linkage (will not fit models w/ CV carbs unless choke hook-up is fabricated, intake manifold purchased and cables modified)	\$549.00
DS-289079	Choke cable accessory kit (required for installation of 40mm carb on 84-89 Big Twin, 86-87 XL Evolution)	66.50



**HIGH-PERFORMANCE CARB KIT**

- Kit includes chrome-plated 40mm carburetor, fittings, adapters and installation instructions
- Offers quicker starts and improved acceleration
- Designed to fit stock manifold and OEM or performance air filters
- Easy bolt-on installation

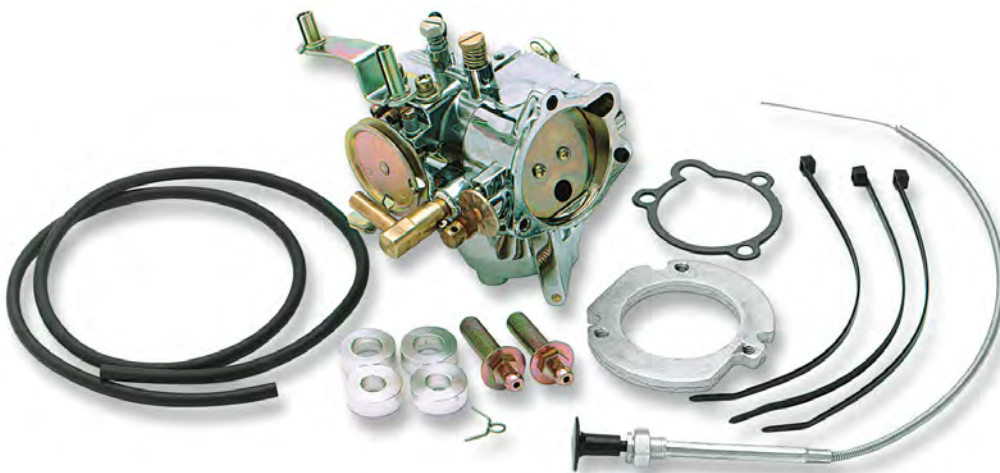

PART #	DESCRIPTION	SUG. RETAIL
1002-0001	For 90-99 Evolution Big Twin models	\$419.95

**DISCLAIMER:** NOT LEGAL FOR SALE OR USE IN CALIFORNIA ON ANY POLLUTION CONTROLLED MOTOR VEHICLES. SEE PAGE 399 FOR IMPORTANT EMISSION DEFINITIONS AND REGULATORY COMPLIANCE AND WARRANTY INFORMATION.

All part numbers in BLUE are new for 2017.



WINDSHIELDS & FAIRINGS

AUDIO & VIDEO

SADDLEBAGS & LUGGAGE

SEATS & SISSY BARS

EXHAUST

FUEL/AIR SYSTEMS

ENGINE

TRANSMISSION & DRIVELINE

GASKETS & SEALS

ELECTRICAL

LIGHTING

HANDLEBARS, CONTROLS & MIRRORS

CABLES

BRAKES

TANKS & OIL FILTERS

DASHES & GAUGES

FRAMES & SUSPENSION

FENDERS & LICENSE PLATE FRAMES

FOOTRESTS

WHEELS & AXLES

HARDWARE, COVERS & GENERAL

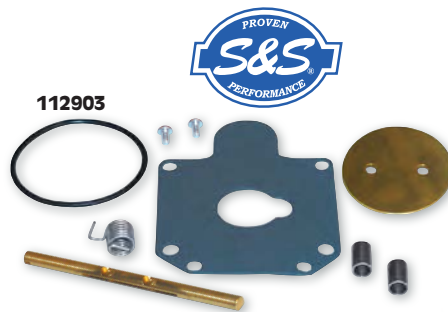

**CARBURETOR REBUILD KITS AND REPLACEMENT COMPONENTS**

- Rebuild kits are available in master kits, body-only kits and accelerator pump kits
- Replacement gaskets, O-rings and components are made from the highest-quality materials available
- Made in the U.S.A.

**REBUILD KITS**

PART #	DESCRIPTION	SUG. RETAIL
112923	Master rebuild kit Super E (body, accelerator pump, fasteners, springs, idle mixture screw, seat and needle assembly)	\$80.95
112924	Master rebuild kit Super G (body, accelerator pump, fasteners, springs, idle mixture screw, seat and needle assembly)	80.95
112903	Rebuild kit for Super B (body rebuild kit)	44.95
DS-289111	Rebuild kit for Super E (body rebuild kit)	40.95
DS-289112	Rebuild kit for Super G (body rebuild kit)	40.95
1003-0312	Rebuild kit for Super E & G basic	34.95
DS-289113	Accelerator pump rebuild kit for E & G (diaphragm, spring, check balls and springs, pushrod and required hardware)	19.95

**REPLACEMENT COMPONENTS**

PART #	DESCRIPTION	SUG. RETAIL (EA.)	PART #	DESCRIPTION	SUG. RETAIL (EA.)
DS-289934	Manifold to carburetor O-ring, Super G (10-pk.)	\$.95	1003-0192	Accelerator pump ejector nozzle O-ring (10-pk.)	\$.95
DS-289935	Manifold to carburetor O-ring, Super E (10-pk.)	.95	1003-0194	Accelerator pump check ball only (10-pk.)	.95
DS-289933	Bowl gasket, Super E and G (10-pk.)	2.95	1003-0193	Accelerator pump cap O-ring (two required) (10-pk.)	.95
112091	Bowl gasket, Super B and D (10-pk.)	1.95	1003-0188	Fuel bowl overflow hose; 24" long (5-pk.)	3.95
160491	.25" Insulator block w/ O-ring Super E	24.95	0706-0203	Straight gas hose for use with the new S&S carbs with 90° fuel inlet	5.75
160492	.25" Insulator block w/ O-ring Super G	24.95	1003-0237	Inlet, 90° carb fuel swivel	22.95
160057	1" Spacer block Super E	53.95	1003-0353	Carb float for Super B, E & G gas carbs	19.95
160357	1" Spacer block Super G	58.95	1050-0360	1 7/8" x 3/8" Super E and G manifold insulator blocks w/ O-ring	24.95
DS-289183	Gas line insulator	13.95	1050-0361	2 1/16" x 3/8" Super E and G manifold insulator blocks w/ O-ring	24.95
1003-0085	Idle mixture screw (5-pk.)	7.95	1003-0452	Super E & G carburetor bowl assembly	70.95
1003-0040	Idle mixture screw spring (10-pk.)	.95	0934-5028	Bowl gasket for Super E & G gas carbs	2.65
1003-0041	Bowl plug (5-pk.)	2.95	0935-0862	O-ring, (-160), 5.250" ID x 5.437" OD, Viton®	3.95
1003-0042	Needle: 1.875" E & 2.0625" G (ea.)	11.95	0935-0863	O-ring, (-013), .437" ID x .565" OD, Viton®	1.00
1003-0043	Bellows seal, accelerator pump (5-pk.)	3.95	0935-0864	O-ring, .390" ID x .510" OD, Silicone	1.25
1003-0044	Diaphragm spring, accelerator pump (10-pk.)	.95	0935-0865	O-ring, (-006), 125" ID x .250" OD, Silicone	1.00
1003-0045	Accelerator pump diaphragm (ea.)	13.95	0935-0866	O-ring, (-009), 7/32" ID x 11/32" OD x 1/16" CS, Silicone	1.05
1003-0047	Fast idle plunger/enrichener (ea.)	11.95	0935-0867	O-ring, (-136), 2" ID x 2.187" OD, Nitrile	1.05
1003-0050	Ball check spring (5-pk.)	1.95	0935-0868	O-ring, (-033), 2" ID x 2.125" OD, Nitrile	1.00
1003-0052	Fuel inlet/seat for 1.875" E & 2.0625" G carb (uses needle 1003-0042) (ea.)	11.95	0935-0869	O-ring, (-223), 1.625" ID x 1.875" OD, Viton®	1.25
1050-0302	Fuel hose and swivel inlet fitting upgrade kit for early-style S&S E and G carburetors	29.95	0935-0870	O-ring, .390" ID x .510" OD, Silicone, (10-pk.)	11.95
1003-0056	Breather conversion kit for Big Twin (converts early S&S air cleaners to new-style breather hardware)	32.95	1003-0454	Tube, ejector nozzle, Super E/G, flared, brass	8.45
112084	Enrichment device for B series carb (will work on Super E & G carbs when changing air cleaners) (ea.)	24.95	1003-0455	Seal, bellows, Super E/G, 2T, Nitrile	3.65
1003-0195	Throttle cable guide/bracket for use w/ CV (constant velocity) cables (ea.)	14.95	1003-0456	Seal, intake, S&S manifolds, 84-16 Big Twin, 86-16 XL	4.95
1003-0196	Throttle cable guide/bracket for use w/ butterfly cables (ea.)	15.95	1003-0457	Seal, intake, stock heads, 84-16 Big Twin, 86-16 XL	4.45
			1003-0459	Lever, enrichment, Super E/G, long, except Buell	7.95
			1003-0460	Screw, slotted, w/ lock washer, 10-24 x 3/4" (10-pk.)	12.95

**DISCLAIMER:** NOT LEGAL FOR SALE OR USE IN CALIFORNIA ON ANY POLLUTION CONTROLLED MOTOR VEHICLES. SEE PAGE 399 FOR IMPORTANT EMISSION DEFINITIONS AND REGULATORY COMPLIANCE AND WARRANTY INFORMATION.

All part numbers in BLUE are new for 2017.



**HOTOP S&S ENRICHENER KNOB ASSEMBLY**

- Replaces the stock S&S enrichener lever on E and G carbs when changing to a different style air cleaner assembly
- Retains the stock plunger and spring
- Setscrew allows progressive enrichment
- Kit includes a chrome knob and a brass plunger nut
- Made in the U.S.A.



PART #	DESCRIPTION	SUG. RETAIL
DS289138	Enrichener knob assembly	\$43.95

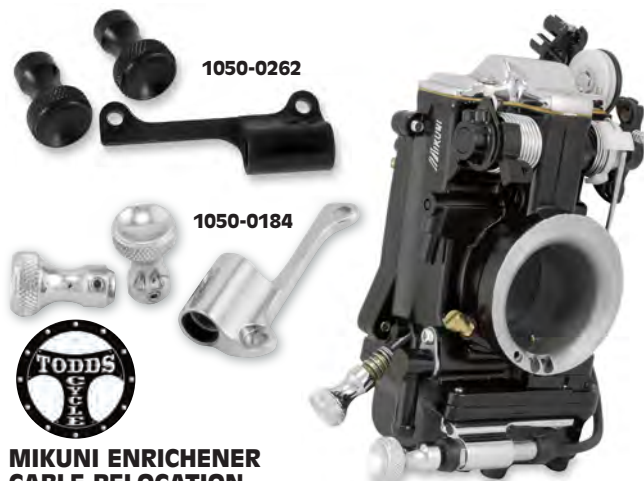

**MIKUNI ENRICHENER CABLE RELOCATION BRACKET KIT AND KNOBS**

- Kit includes bracket, idle mixture screw knob and enrichener cable knob
- CNC-machined billet aluminum components
- Available in a black finish
- Made in the U.S.A.

**NOTE:** Must be used with Mikuni enrichener cable, Drag Specialties PART #990-662-002.

PART #	DESCRIPTION	SUG. RETAIL
1050-0183	Bracket kit w/ enrichener and idle knobs, chrome	\$134.95
1050-0262	Bracket kit w/ enrichener and idle knobs, black	134.95
1050-0184	Bracket kit w/ enrichener and idle knobs, raw	99.95



**CV CARB TOP COVERS**

- Hand-polished investment cast CNC-machined 6061 T-6 billet aluminum available in gloss black powder-coated or raw polished aluminum
- Fit CV carburetors on late model Harley-Davidson Sportster, Evolution, Twin Cam and custom applications where Keihin CV carb might be used
- Feature a classic finned look or the popular rippled-water-droplet look; a classic styling element

FOR 88-06 H-D CV40/44 CARBURETORS		
PART #	DESCRIPTION	SUG. RETAIL
<b>RIPPLE</b>		
1015-0133	Polished aluminum	\$29.95
1015-0125	Black powdercoat aluminum	29.95
<b>FINNED</b>		
1015-0135	Polished aluminum	29.95
1015-0134	Black powdercoat aluminum	29.95

**DISCLAIMER:** NOT LEGAL FOR SALE OR USE IN CALIFORNIA ON ANY POLLUTION CONTROLLED MOTOR VEHICLES. SEE PAGE 399 FOR IMPORTANT EMISSION DEFINITIONS AND REGULATORY COMPLIANCE AND WARRANTY INFORMATION.

All part numbers in BLUE are new for 2017.



**ECN ENRICHENER CABLE RELOCATION BRACKETS**

- Relocates enrichener cable and knob out of the way
- For use with stock enrichener cables and knobs
- Made from stainless steel with ball-burnished finish
- Made in the U.S.A.

PART #	DESCRIPTION	SUG. RETAIL
1050-0226	For all Mikuni HSR carbs	\$31.95
1050-0227	For all Keihin CV carbs	31.95



**FUEL INLET FITTING**

- Solid brass fitting
- Accepts 1/4" fuel line
- For 84-06 Keihin butterfly and CV carburetors
- Sold each

PART #	DESCRIPTION	SUG. RETAIL
1003-0257	Fuel inlet fitting; repl. OEM #27371-76A	\$5.95

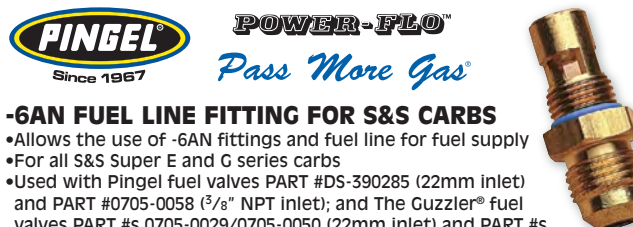

**-6AN FUEL LINE FITTING FOR S&S CARBS**

- Allows the use of -6AN fittings and fuel line for fuel supply
- For all S&S Super E and G series carbs
- Used with Pingel fuel valves PART #DS-390285 (22mm inlet) and PART #0705-0058 (3/8" NPT inlet); and The Guzzler® fuel valves PART #S 0705-0029/0705-0050 (22mm inlet) and PART #S 0705-0028/0705-0056 (3/8" NPT inlet)
- Sold each
- Made in the U.S.A.

PART #	DESCRIPTION	SUG. RETAIL
DS-289141	-6AN fuel fitting	\$41.95



**HI-FLOW FUEL NIPPLES**

- Flow more fuel than the stock OEM nipples
- Include removal tool
- Made in the U.S.A.

PART #	DESCRIPTION	SUG. RETAIL
<b>FOR ALL 76-06 KEIHING CARBURETORS (BUTTERFLY AND CV)</b>		
1050-0123	Single outlet (brass)	\$42.95
1050-0208	Single outlet (stainless-steel)	47.95



**SMOOTH CHROME CV CARB TOP COVER**

- Smooth die-cast chrome cover replaces the OEM black plastic top cover
- Installation is a snap; just remove the four OEM screws and bolt on the new cover with them

PART #	DESCRIPTION	SUG. RETAIL
DS-288801	For 88-06 Harley CV carb models; repl. OEM #27040-88	\$15.95

WINDSHIELDS & FAIRINGS

AUDIO & VIDEO

SADDLEBAGS & LUGGAGE

SEATS & SISSY BARS

EXHAUST

FUEL/AIR SYSTEMS

ENGINE

TRANSMISSION & DRIVELINE

GASKETS & SEALS

ELECTRICAL

LIGHTING

HANDLEBARS, CONTROLS & MIRRORS

CABLES

BRAKES

TANKS & OIL FILTERS

DASHES & GAUGES

FRAMES & SUSPENSION

FENDERS & LICENSE PLATE FRAMES

FOOTRESTS

WHEELS & AXLES

HARDWARE, COVERS & GENERAL

WINDSHIELDS & FAIRINGS

AUDIO & VIDEO

SADDLEBAGS & LUGGAGE

SEATS & SISSY BARS

EXHAUST

FUEL/AIR SYSTEMS

ENGINE

TRANSMISSION & DRIVELINE

GASKETS & SEALS

ELECTRICAL

LIGHTING

HANDLEBARS, CONTROLS & MIRRORS

CABLES

BRAKES

TANKS & OIL FILTERS

DASHES & GAUGES

FRAMES & SUSPENSION

FENDERS & LICENSE PLATE FRAMES

FOOTRESTS

WHEELS & AXLES

HARDWARE, COVERS & GENERAL

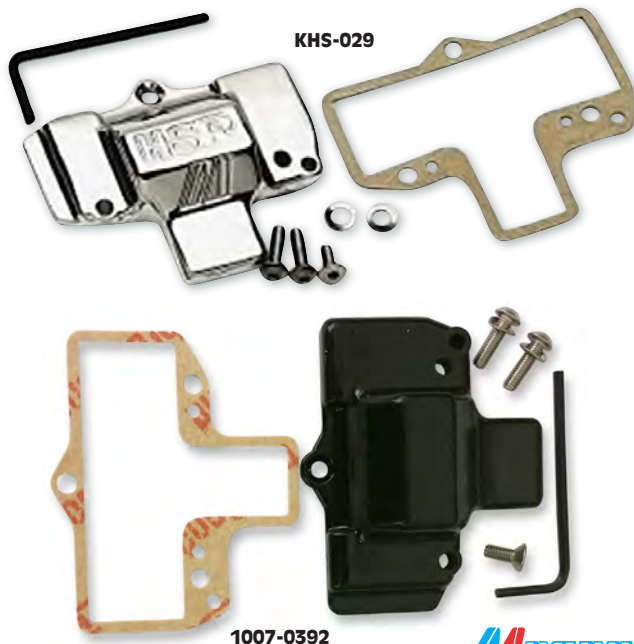

KHS-029

1007-0392



**MIKUNI CARB TOP COVERS**

- Highly polished chrome or black covers give a unique custom look
- Available with or without embossed Mikuni logo
- Made in Japan

PART #	DESCRIPTION	SUG. RETAIL
<b>FOR MIKUNI HSR CARBURETORS</b>		
KHS-029	Chrome cover w/ Mikuni logo	\$28.95
KHS-028	Chrome cover w/o Mikuni logo	28.95
1007-0392	Black cover w/o Mikuni logo	28.95



**CV CARBURETOR TOP COVER**

- Machined from 6061-T6 billet aluminum, polished to a high luster and chrome-plated
- Relocate choke cable for easier access
- Smooth with choke cable bracket
- Made in the U.S.A.

PART #	DESCRIPTION	SUG. RETAIL
1015-0096	For 88-06 CV40/44 carburetors on Big Twin, XL and Buell	\$59.95



1050-0158



**FLOAT BOWL SPEED SCREW KITS**

- Electropolished stainless steel for a great custom look
- Will not corrode in extreme climates
- Longer and stronger than the stock screws, makes them easier to handle; will not round off
- 5/16" hex head design eases bowl removal and jet changing
- Made in the U.S.A.

PART #	DESCRIPTION	SUG. RETAIL
1050-0158	For CV/HSR carbs	\$34.95
1050-0160	For S&S E&G carbs	34.95



DS-190129



**GARDNER WESTCOTT**

**CARBURETOR SOCKET-HEAD BOLT KITS**

- Replace the stock screws with strong chrome socket-head bolts
- For use on CV carburetors and S&S carburetors
- Made in the U.S.A.

PART #	DESCRIPTION	SUG. RETAIL
DS-190129	For CV carburetor on 90-06 Big Twin and 88-03 XL models	\$28.95
DS-190695	For top cover only on 88-06 CV carburetors	11.95
DS-190697	For S&S E and G carburetor body and air cleaner	35.95



DS-190697



**CHOKE CABLE MOUNT**

- Bracket mounts directly to the top of a CV carburetor and allows the choke cable to be relocated without dismantling it (which all other styles require)
- Made from stainless steel with a tumbled finish
- Works great with Gasbox Dog Dish air cleaners
- Made in the U.S.A.



PART #	DESCRIPTION	SUG. RETAIL
1050-0362	Choke cable mount	\$29.95

**DISCLAIMER:** NOT LEGAL FOR SALE OR USE IN CALIFORNIA ON ANY POLLUTION CONTROLLED MOTOR VEHICLES. SEE PAGE 399 FOR IMPORTANT EMISSION DEFINITIONS AND REGULATORY COMPLIANCE AND WARRANTY INFORMATION.

All part numbers in **BLUE** are new for 2017.

HS42/001-K



**HSR4 MAIN JET EXTENSION KIT**

- Increases amount of fuel to float bowl
- Completely submerges main jet within extender, eliminating chance of air bubbles getting through
- Made in Japan

**REPLACEMENT PARTS FOR HSR 42/45 CARB KITS**

•Made in Japan

PART #	DESCRIPTION	SUG. RETAIL
HS42/001-K	Mikuni-to-CV carb air box adapter w/ three mounting screws	\$21.95
990-605-065	Short idle screw adjuster	16.95
990-662-002	Choke cable, for use with Mikuni plastic nut, spring and brass plunger	29.95

PART #	DESCRIPTION	SUG. RETAIL
1006-0248	HSR4 main jet extension kit	\$29.95



**GENUINE MIKUNI HS CARBURETOR REBUILD KITS**

- Genuine Mikuni parts properly replace worn or mistreated components for HSR42/45/48 carburetors
- Includes top cover gasket, jet needle E-ring and washer, throttle valve seal, pilot air O-ring, fuel joint O-ring, accelerator pump O-ring, needle valve O-ring, needle valve retainer screw, needle valve assembly, float bowl O-ring/gasket, overflow hose, float bowl screws, accelerator pump rod boot
- Includes all the parts needed to rebuild HSR42/45 or HSR48 carburetors

KHS-016

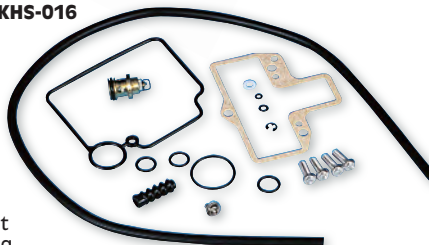

KHS-031

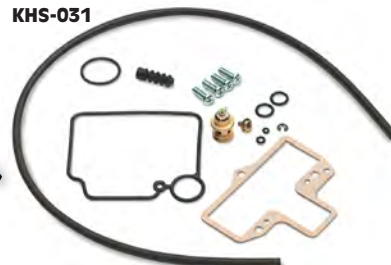

PART #	DESCRIPTION	SUG. RETAIL	PART #	DESCRIPTION	SUG. RETAIL
KHS-016	HSR42/45 Carb rebuild kit	\$43.50	KHS-031	HSR48 Carb rebuild kit	\$43.50



**CARB REBUILD KIT FOR MIKUNI**

- Includes all required parts to completely rebuild a carb
- For HSR42/45mm carburetors

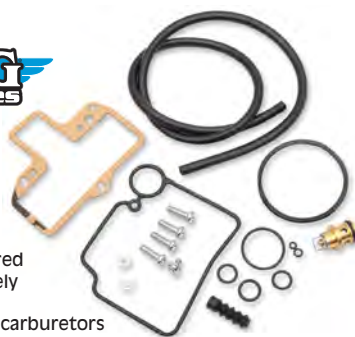

PART #	DESCRIPTION	SUG. RETAIL
1003-0293	Rebuild kit for HSR42/45 mm carbs	\$36.95

1003-0292



**CARB REBUILD KITS FOR KEIHIN**

- Kits include all necessary parts to rebuild a butterfly-style or CV-style Keihin carb

PART #	DESCRIPTION	SUG. RETAIL
1003-0292	For 88-06 Keihin CV carbs	\$17.95
1003-0291	For 84-89 Keihin butterfly carbs	17.95

1003-0291



DS-289089



**CARB REBUILD KIT FOR KEIHIN CV**

- For use with all 90-06 Big Twin or 88-06 XL models using the CV carb
- Includes all the necessary needles, O-rings, seals and gaskets etc. for a complete rebuild

PART #	DESCRIPTION	SUG. RETAIL
DS-289109	For all 88-06 CV carbs	\$42.95



DS-289098



**REBUILD KIT FOR KEIHIN CARB**

- Includes the parts necessary for rebuilding carbs
- PART #DS-289089 features Viton (not neoprene) needles

PART #	DESCRIPTION	SUG. RETAIL
DS-289089	For 84-89 butterfly carbs; repl. OEM #27006-76	\$22.95
DS-289098	For all 88-06 CV carbs	21.95



**GENUINE BENDIX CARB REBUILD KIT**

- Rebuild kit includes all necessary gaskets, seals, idle screw and accelerator pump

PART #	DESCRIPTION	SUG. RETAIL
DS-289084	40mm Bendix rebuild kit for 84-89	\$57.95

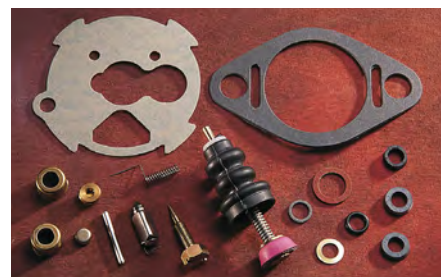

**DISCLAIMER:** NOT LEGAL FOR SALE OR USE IN CALIFORNIA ON ANY POLLUTION CONTROLLED MOTOR VEHICLES. SEE PAGE 399 FOR IMPORTANT EMISSION DEFINITIONS AND REGULATORY COMPLIANCE AND WARRANTY INFORMATION.

All part numbers in BLUE are new for 2017.

WINDSHIELDS & FAIRINGS

AUDIO & VIDEO

SADDLEBAGS & LUGGAGE

SEATS & SISSY BARS

EXHAUST

FUEL/AIR SYSTEMS

ENGINE

TRANSMISSION & DRIVELINE

GASKETS & SEALS

ELECTRICAL

LIGHTING

HANDLEBARS, CONTROLS & MIRRORS

CABLES

BRAKES

TANKS & OIL FILTERS

DASHES & GAUGES

FRAMES & SUSPENSION

FENDERS & LICENSE PLATE FRAMES

FOOTRESTS

WHEELS & AXLES

HARDWARE, COVERS & GENERAL

WINDSHIELDS & FAIRINGS

AUDIO & VIDEO

SADDLEBAGS & LUGGAGE

SEATS & SISSY BARS

EXHAUST

FUEL/AIR SYSTEMS

ENGINE

TRANSMISSION & DRIVELINE

GASKETS & SEALS

ELECTRICAL

LIGHTING

HANDLEBARS, CONTROLS & MIRRORS

CABLES

BRAKES

TANKS & OIL FILTERS

DASHES & GAUGES

FRAMES & SUSPENSION

FENDERS & LICENSE PLATE FRAMES

FOOTRESTS

WHEELS & AXLES

HARDWARE, COVERS & GENERAL



**CRUISE CONTROL BRACKET FOR MIKUNI**

- Fits all years with Mikuni HSR42/45/48 using stock cables
- Retains cruise control when adding a Mikuni/Screamin' Eagle carb
- Made in the U.S.A.

PART #	DESCRIPTION	SUG. RETAIL
1013-0034	For Mikuni HSR42/45/48 carbs	\$147.95



**ACCELERATOR PUMP DIAPHRAGM**

- Sold each
- Made in the U.S.A.



PART #	DESCRIPTION	SUG. RETAIL
DS-174445	For 85-89 Big Twin, 86-89 XL w/ OEM Keihin carb; repl. OEM #27361-76	\$13.95



**IDLE AIR ADJUSTING SCREWS FOR ALL CV CARBURETORS**

- Knurled and slotted head for easy adjustment
- Includes brass or stainless-steel screw, O-ring, washer and spring
- Made in the U.S.A.



PART #	DESCRIPTION	SUG. RETAIL
1050-0172	Brass screw	\$29.95
1050-0207	Stainless-steel screw	29.95



**AIR MIXTURE SCREW KIT**

- Air mixture screw kit includes: washer, spring and ring air idle mixture needle repacking kit



PART#	DESCRIPTION	SUG. RETAIL
1003-0352	Packing kit mixture screw for CV carbs	\$8.95



**IDLE AIR ADJUSTING SCREWS**

- Available for both butterfly-type and CV-type carbs
- Knurled head is slotted for quick, simple adjustment



PART #	DESCRIPTION	SUG. RETAIL
1050-0289	For butterfly-type carbs	\$29.95
1050-0290	For CV-type carbs	29.95



**DIAPHRAGM REBUILD KIT**

- Carburetor Diaphragm rebuild kit for all Keihin carbs (including late CV carb)
- Replaces diaphragm on S&S "E" and "G" carbs
- Kit is complete with upgraded rubber components; diaphragm, 2 O-rings, boot and spring to completely rebuild the accelerator pump



PART#	DESCRIPTION	SUG. RETAIL
1003-0351	Diaphragm rebuild kit	\$10.95



**VACUUM PISTON ASSEMBLY**

- Replaces the stock assembly



PART #	DESCRIPTION	SUG. RETAIL
1050-0288	For 88-06 CV and CVK Keihin carburetors; repl. OEM #27585-88	\$46.95



**40MM CV VACUUM PISTON**

- Genuine Keihin replacement
- Made in Japan



NOTE: No warranty on rubber diaphragm.

PART #	DESCRIPTION	SUG. RETAIL
2101-0008	For 88-06 40mm carb; repl. OEM #27585-88	\$41.95

**DISCLAIMER:** NOT LEGAL FOR SALE OR USE IN CALIFORNIA ON ANY POLLUTION CONTROLLED MOTOR VEHICLES. SEE PAGE 399 FOR IMPORTANT EMISSION DEFINITIONS AND REGULATORY COMPLIANCE AND WARRANTY INFORMATION.

All part numbers in BLUE are new for 2017.



Performance Products

**CARBURETOR SPACERS**

- Easy way to add extra torque and horsepower
- Machined from solid 6061 T-6 billet aluminum that completely eliminates porosity problems
- Machined finish can be polished to a bright luster
- Made in the U.S.A.



PART #	DESCRIPTION	SUG. RETAIL
<b>FOR S&amp;S E &amp; B SERIES CARBURETORS (1 7/8")</b>		
1013-0004	1"	\$33.95
1013-0005	1 1/2"	39.95
1013-0006	2"	39.95

PART #	DESCRIPTION	SUG. RETAIL
<b>FOR S&amp;S G &amp; D SERIES CARBURETORS (2 1/16")</b>		
1013-0007	1"	\$33.95
1013-0008	1 1/2"	39.95
1013-0009	2"	39.95

WINDSHIELDS & FAIRINGS

AUDIO & VIDEO

SADDLEBAGS & LUGGAGE

SEATS & Sissy BARS

EXHAUST

FUEL/AIR SYSTEMS

ENGINE

TRANSMISSION & DRIVELINE

GASKETS & SEALS

ELECTRICAL

LIGHTING

HANDLEBARS, CONTROLS & MIRRORS

CABLES

BRAKES

TANKS & OIL FILTERS

DASHES & GAUGES

FRAMES & SUSPENSION

FENDERS & LICENSE PLATE FRAMES

FOOTRESTS

WHEELS & AXLES

HARDWARE, COVERS & GENERAL



**CARBURETOR INSULATOR BLOCK KIT**

- Kit includes 3/8" fiber insulator block and gaskets
- Designed to reduce the risk of boiling fuel in the carb
- Made in the U.S.A.

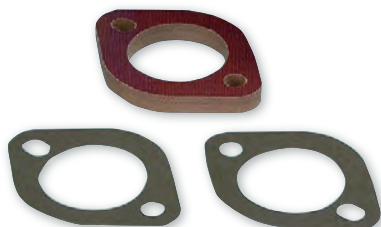

PART #	DESCRIPTION	SUG. RETAIL
2011-1214	For custom applications; 1.86" i.d. w/ 2 3/4" center-to-center mounting holes	\$21.95



**INTAKE MANIFOLD AND CARB SEAL KIT**

- Kit contains one carburetor to intake seal (27002-89) and two intake to cylinder head seals (26995-86B)
- Made in the U.S.A.

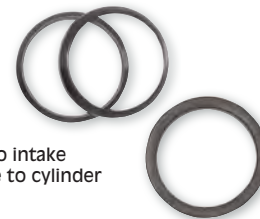

PART #	DESCRIPTION	SUG. RETAIL
0935-0172	40mm seal kit for 99-06 Twin Cam, 90-99 90" Evolution and 88-06 XL w/ OEM carbs	\$8.95



**CARBURETOR AND INTAKE MANIFOLD SEAL KITS**

- Kits contain carb-to-intake seal and two intake-to-cylinder head seals unless noted



PART #	DESCRIPTION	SUG. RETAIL
DS-174381	40mm seal kit for 99-06 Twin Cam, 90-99 80" Evolution and 88-06 XL w/ Original Equipment carbs	\$12.95
DS-173537	44mm seal kit for 99-06 Twin Cam, 90-99 80" Evolution and 88-06 XL w/ Screaming Eagle carbs	12.95
0935-0085	#1671 Edelbrock manifold seal kit	8.95

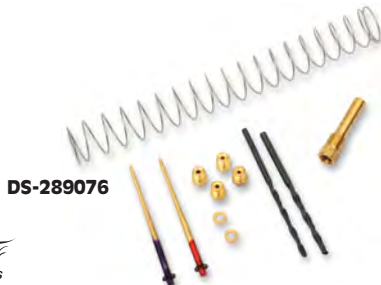

DS-289076



**THE ORIGINAL "POWER TUBE" ATOMIZER**

- Atomizer power tube and jets are CNC-machined from brass for consistency and accuracy
- Power tube jet kits provide fine tuning with increased horsepower when using a less restrictive air cleaner and exhaust
- Converts fuel from a squirting liquid to a fine mist
- Eliminates spitting and popping through the carburetor
- Master kits include slow jets, main jets, slide spring, drill bit and needles
- Made in the U.S.A.

NOTE: Covered under the following U.S. patent #s: 5,233,180/5,562,868/5,662,836/5,810,264/6,270,060.

PART #	DESCRIPTION	SUG. RETAIL
DS-289076	Performance master kit for 88-06 stock 40mm CV carbs	\$105.95
DS-289075	Power Tube for HSR 42 and 45 w/ jets	60.95
1007-0157	Power Tube for HSR 42 and 45 (w/o jets)	56.95



DS-289075



1007-0157

DS-289121

DS-289120

**NO-HASSLE JET KITS FOR CV CARBURETORS**

- Genuine Keihin parts
- Includes two slow jets, two main jets and a jet needle
- No need for drilling
- Detailed instructions for jetting your motor from stock to modified



PART #	DESCRIPTION	SUG. RETAIL
DS-289331	For 90-99 Evolution Big Twin	\$39.95
1007-0015	For 04-06 XL 883/1200	38.95
DS-289332	For 88-03 XL 1200 (except 97-03 1200S)	39.95

PART #	DESCRIPTION	SUG. RETAIL
DS-289334	For 97-03 XL1200S, 94-98 Buell S1, S2/S2T, S3/S3T and M2	\$39.95
DS-289333	For 88-03 XL 883	39.95



DS-289331

**DISCLAIMER:** NOT LEGAL FOR SALE OR USE IN CALIFORNIA ON ANY POLLUTION CONTROLLED MOTOR VEHICLES. SEE PAGE 399 FOR IMPORTANT EMISSION DEFINITIONS AND REGULATORY COMPLIANCE AND WARRANTY INFORMATION.

All part numbers in BLUE are new for 2017.



WINDSHIELDS & FAIRINGS

AUDIO & VIDEO

SADDLEBAGS & LUGGAGE

SEATS & SISSY BARS

EXHAUST

FUEL/AIR SYSTEMS

ENGINE

TRANSMISSION & DRIVELINE

GASKETS & SEALS

ELECTRICAL

LIGHTING

HANDLEBARS, CONTROLS & MIRRORS

CABLES

BRAKES

TANKS & OIL FILTERS

DASHES & GAUGES

FRAMES & SUSPENSION

FENDERS & LICENSE PLATE FRAMES

FOOTRESTS

WHEELS & AXLES

HARDWARE, COVERS & GENERAL

DS-289306



**RECALIBRATION KITS**

- Recalibrate your stock Keihin CV carb to make full use of the performance potential
- Include the jets, needles, instructions, etc. necessary to recalibrate stock engines with CV carbs
- Kits provide broad-range performance gains and maintain stock driveability

PART #	DESCRIPTION	SUG. RETAIL	PART #	DESCRIPTION	SUG. RETAIL
DS-290347	For 00-06 Twin Cam	\$109.95	1007-0001	For 04-06 XL 883	\$109.95
DS-290148	For 99 Twin Cam	109.95	DS-289451	For 98-03 XL1200 Sport	109.95
DS-289306	For 96-99 80" Big Twin and 96-03 XL	109.95	1007-0002	For 04-06 XL 1200	109.95
DS-289303	For 90-95 Big Twin, XL 883, 1200	109.95	DS-289309	For 99-02 Buell M2 Cyclone	109.95
DS-289450	For 89-03 XL 883 "race only"	109.95	DS-290348	For 00-02 Buell blast	109.95

DS-290356



**STAGE 7 THUNDERSLIDE WITH JET KITS**

- Stage 7 kits are for 80 plus horsepower engines and include a taller carburetor top for more slide movement
- Revolutionary composite plastic slide provides unparalleled performance gains in both horsepower and mileage
- Unique set of lift holes moderate how the slide moves with respect to throttle position; the faster the slide opens, the quicker the throttle response
- Kits include jets, needles, clips, carburetor top and other necessary parts for CV carbs
- Made in the U.S.A.

PART #	DESCRIPTION	SUG. RETAIL	PART #	DESCRIPTION	SUG. RETAIL
DS-290356	For 00-06 Twin Cam	\$184.95	DS-290351	For Screamin' Eagle 44mm Keihin CV Twin Cam 88	\$184.95
DS-290352	For 90-99 Big Twin Evolution	184.95	DS-290350	For Screamin' Eagle 44mm Keihin CV Evolution	184.95

DS-289307



**THUNDERSLIDE JET KITS**

- Designed for engines with stock or aftermarket air filter and exhaust system
- Revolutionary composite plastic slide provides unparalleled performance gains in both horsepower and mileage
- Unique set of lift holes moderate how the slide moves with respect to throttle position; the faster the slide opens, the quicker the throttle response
- Kit also includes jets, needles, clips and other necessary parts for CV carbs
- Made in the U.S.A.

PART #	DESCRIPTION	SUG. RETAIL	PART #	DESCRIPTION	SUG. RETAIL
DS-290349	For 00-06 Twin Cam	\$164.95	DS-289308	For 89-03 XL 1200 (not Sport) (Stage 1)	\$164.95
DS-290149	For 99 Twin Cam	164.95	DS-289454	For 98-03 XL 1200 Sport (Stage 1)	164.95
DS-289307	For 90-99 Evolution Big Twin	164.95	1007-0005	For 04-06 XL 1200/C/R	164.95

**DISCLAIMER:** NOT LEGAL FOR SALE OR USE IN CALIFORNIA ON ANY POLLUTION CONTROLLED MOTOR VEHICLES. SEE PAGE 399 FOR IMPORTANT EMISSION DEFINITIONS AND REGULATORY COMPLIANCE AND WARRANTY INFORMATION.

All part numbers in **BLUE** are new for 2017.



**CARBURETOR JET KITS**

- Designed to recalibrate OEM stock carburetors for use with Vance & Hines exhaust systems
- Include complete needle assemblies with five ranges of adjustment, main jets, clips, washer and appropriate drill bits
- Include detailed instructions for easy installation

**DISCLAIMER: FOR CLOSED COURSE COMPETITION USE ONLY. NOT INTENDED FOR STREET USE.**



PART #	DESCRIPTION	SUG. RETAIL
V22827	For 00-06 Twin Cam models	\$97.99
V22831	For 00-05 Buell Blast	97.99



**CV CARB JET KIT**

- Recalibrate your stock CV carb to make the most out of the air cleaner, exhaust and cam changes or head work
- Kit contains a #5 MAHR needle, 08 BOO jet holder, #45, #48 and #50 slow jets, and #190, #195, #200 and #205 main jets
- Suggested jetting guidelines are included with the kit
- Made in the U.S.A.



PART #	DESCRIPTION	SUG. RETAIL
DS-195100	For 99-06 Twin Cam	\$56.95



**RECALIBRATION KIT FOR 40MM KEIHIN CV CARB**

- Super high-quality recalibration kit for CV carbs
- Kit has all the components for dialing in a CV carb with or without an accelerator pump



PART #	DESCRIPTION	SUG. RETAIL
DS-289304	For all 88-99 CV carbs (except Twin Cam 88)	\$62.95



**CV MAIN JET KIT**

- Kit contains 195, 200, 205, 210, 215 and 220 main jets
- Made in the U.S.A.



PART #	DESCRIPTION	SUG. RETAIL
DS-289186	For CV carbs on 90-06 Big Twin and 88-06 XL models	\$20.95

**QUICKSHOT**

- Cost-effective, bolt-on upgrade that allows accelerator pump fuel spray to be adjusted simply with the turn of a screw
- Patent-pending design
- Accelerator pump check valve stops bogging and coughing
- Adjustable fuel jet to control accelerator pump spray
- Precision single hole sprayer tip directs and injects the fuel more efficiently than stock
- A fine high-speed stream of fuel atomizes faster to improve roll-on acceleration
- Instant throttle response
- Improves low end performance and fuel economy
- Easy bolt-on; no modifications necessary



PART #	DESCRIPTION	SUG. RETAIL
1050-0241	Quickshot for S&S Super E & G carburetors	\$99.95



**TWINSHOT ADJUSTABLE FUEL CONTROL**

- Cost-effective, bolt-on upgrade eliminates the sluggish and inconstant throttle response of CV-40-carbureted H-D models
- Converts all OEM CV-40 carburetors to a standardized fuel system
- Precision twin-hole sprayer for improved roll-on acceleration
- Patented Quickshot accelerator pump technology eliminates low-speed bogging and coughing
- Adjustable fuel jet to control accelerator pump fuel spray
- Dual check valve system for consistent spray pressure
- Removable sprayer allows convenient service and maintenance
- Removable main jet cap for easy access tuning
- Precision accelerator pump plunger rod improves spray response
- Stiffer spring on activation arm delivers consistent spray response
- Available in polished aluminum or matte black finish
- Bolt-on, no modifications required
- Includes new float bowl O-ring, new plunger arm and plunger arm boot
- Made in the U.S.A.

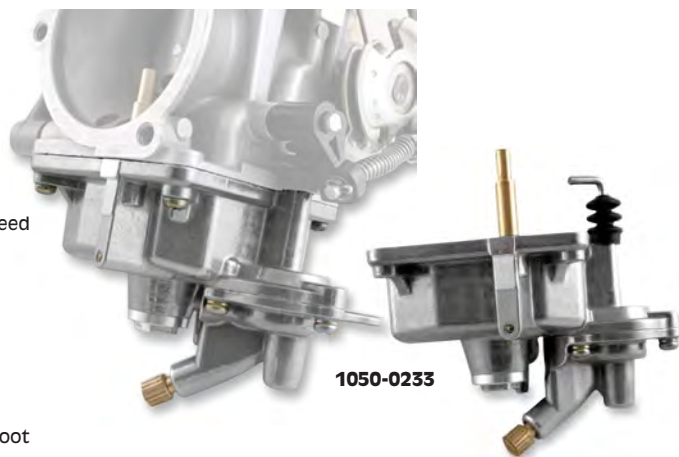

PART #	DESCRIPTION	SUG. RETAIL	PART #	DESCRIPTION	SUG. RETAIL
1050-0233	Polished aluminum	\$179.95	1050-0234	Matte black	\$179.95

**DISCLAIMER: NOT LEGAL FOR SALE OR USE IN CALIFORNIA ON ANY POLLUTION CONTROLLED MOTOR VEHICLES. SEE PAGE 399 FOR IMPORTANT EMISSION DEFINITIONS AND REGULATORY COMPLIANCE AND WARRANTY INFORMATION.**

All part numbers in BLUE are new for 2017.

WINDSHIELDS & FAIRINGS

AUDIO & VIDEO

SADDLEBAGS & LUGGAGE

SEATS & SISSY BARS

EXHAUST

FUEL/AIR SYSTEMS

ENGINE

TRANSMISSION & DRIVELINE

GASKETS & SEALS

ELECTRICAL

LIGHTING

HANDLEBARS, CONTROLS & MIRRORS

CABLES

BRAKES

TANKS & OIL FILTERS

DASHES & GAUGES

FRAMES & SUSPENSION

FENDERS & LICENSE PLATE FRAMES

FOOTRESTS

WHEELS & AXLES

HARDWARE, COVERS & GENERAL



WINDSHIELDS & FAIRINGS

AUDIO & VIDEO

SADDLEBAGS & LUGGAGE

SEATS & SISSY BARS

EXHAUST

FUEL/AIR SYSTEMS

ENGINE

TRANSMISSION & DRIVELINE

GASKETS & SEALS

ELECTRICAL

LIGHTING

HANDLEBARS, CONTROLS & MIRRORS

CABLES

BRAKES

TANKS & OIL FILTERS

DASHES & GAUGES

FRAMES & SUSPENSION

FENDERS & LICENSE PLATE FRAMES

FOOTRESTS

WHEELS & AXLES

HARDWARE, COVERS & GENERAL

**JET KITS FOR S&S CARBS**

- For jetting most stock and performance engines
- Dealer jet kit contains three each of all intermediate jets (except 1005-0008 and 1005-0009) and five each of all main jets (except 1006-0233, 1006-0234, 1006-0235, 1006-0236, 1006-0237 and 1006-0238) plus a main jet tool
- Master jet kit contains one of all intermediate jets (.025, .0265, .028, .0295, .031, .032, and .033 inch) and one of all main jets (.062, .064, .066, .068, .070, .072, .074, .076, .078, .080, .082, and .084 inch)
- Low-range kit contains one each of the following intermediate jets (.025, .0265, .028, .0295) and one each of the following main jets (.062, .064, .066, .068, .070, .072, .074)
- High-range kit contains one each of the following intermediate jets (.0295, .031, .032, .033) and one each of the following main jets (.072, .074, .076, .078, .080, .082, .084)
- Replacement jets also available separately
- Made in the U.S.A.



1007-0402

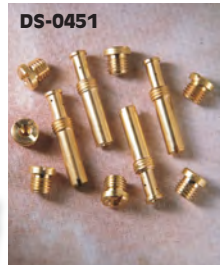

DS-0451

PART #	DESCRIPTION	SUG. RETAIL (EA.)
<b>JET KITS</b>		
1005-0015	Dealer jet kit	\$317.95
1007-0402	Master jet kit for all Super B, E and G carbs	80.95
DS-0450	Low-range kit	46.95
DS-0451	High-range kit	46.95
<b>INTERMEDIATE JETS</b>		
DS-94025	.025 intermediate jet (3-pk.)	7.95
DS-940265	.0265 intermediate jet (3-pk.)	7.95
DS-94028	.028 intermediate jet (3-pk.)	7.95
DS-940295	.0295 intermediate jet (3-pk.)	7.95
DS-94031	.031 intermediate jet (3-pk.)	7.95
DS-94032	.032 intermediate jet (3-pk.)	7.95
DS-94033	.033 intermediate jet (3-pk.)	7.95

PART #	DESCRIPTION	SUG. RETAIL (EA.)
<b>INTERMEDIATE JETS (CONT)</b>		
1005-0008	.036 intermediate jet (3-pk.)	\$7.95
1005-0009	.040 intermediate jet (3-pk.)	7.95
<b>MAIN JETS</b>		
1006-0228	.040 main jet (5-pk.)	7.95
1006-0229	.042 main jet (5-pk.)	7.95
1006-0230	.044 main jet (5-pk.)	7.95
1006-0231	.046 main jet (5-pk.)	7.95
1006-0232	.048 main jet (5-pk.)	7.95
1006-0233	.050 main jet (5-pk.)	7.95
1006-0234	.052 main jet (5-pk.)	7.95
1006-0235	.054 main jet (5-pk.)	7.95
1006-0236	.056 main jet (5-pk.)	7.95
1006-0237	.058 main jet (5-pk.)	7.95

PART #	DESCRIPTION	SUG. RETAIL (EA.)
<b>MAIN JETS (CONT)</b>		
1006-0238	.060 main jet (5-pk.)	\$7.95
DS-72062	.062 main jet (5-pk.)	7.95
DS-72064	.064 main jet (5-pk.)	7.95
DS-72066	.066 main jet (5-pk.)	7.95
DS-72068	.068 main jet (5-pk.)	7.95
DS-72070	.070 main jet (5-pk.)	7.95
DS-72072	.072 main jet (5-pk.)	7.95
DS-72074	.074 main jet (5-pk.)	7.95
DS-72076	.076 main jet (5-pk.)	7.95
DS-72078	.078 main jet (5-pk.)	7.95
DS-72080	.080 main jet (5-pk.)	7.95
DS-72082	.082 main jet (5-pk.)	7.95
DS-72084	.084 main jet (5-pk.)	7.95

**MAIN JETS FOR CV-TYPE KEIHIN CARBS**

- Precision-made in Japan
- Master jet kit consists of 14 five-packs, includes jets from #140 to #250; you furnish box
- Individual jets sold to dealer in five-packs; sold to consumer each



DS-289321

PART #	DESCRIPTION	SUG. RETAIL (EA.)
<b>FOR 90-06 BIG TWIN AND 88-06 XL</b>		
DS289538	Master jet kit	\$241.95
DS289533	#140 main jet (5-pk.)	4.25
DS289534	#145 main jet (5-pk.)	4.25
DS289535	#150 main jet (5-pk.)	4.25
DS289536	#155 main jet (5-pk.)	4.25

PART #	DESCRIPTION	SUG. RETAIL (EA.)
<b>FOR 90-06 BIG TWIN AND 88-06 XL (CONT)</b>		
DS-289321	#160 main jet (5-pk.)	\$4.25
DS-289322	#165 main jet (5-pk.)	4.25
DS-289323	#170 main jet (5-pk.)	4.25
DS-289324	#175 main jet (5-pk.)	4.25
DS-289325	#180 main jet (5-pk.)	4.25

PART #	DESCRIPTION	SUG. RETAIL (EA.)
<b>FOR 90-06 BIG TWIN AND 88-06 XL (CONT)</b>		
DS-289326	#185 main jet (5-pk.)	\$4.25
DS-289327	#190 main jet (5-pk.)	4.25
DS-289328	#195 main jet (5-pk.)	4.25
DS-289329	#200 main jet (5-pk.)	4.25
DS289537	#205 main jet (5-pk.)	4.25

PART #	DESCRIPTION	SUG. RETAIL (EA.)
<b>FOR 90-06 BIG TWIN AND 88-06 XL (CONT)</b>		
1006-0279	#210 main jet (5-pk.)	\$4.25
1006-0280	#220 main jet (5-pk.)	4.25
1006-0281	#230 main jet (5-pk.)	4.25
1006-0282	#240 main jet (5-pk.)	4.25
1006-0283	#250 main jet (5-pk.)	4.25

**PILOT JETS FOR KEIHIN CARBS**

- Available for both styles (butterfly and CV) of Keihin carbs 76-06
- Precision-made in Japan
- Master kit for CV-style consists of nine five-packs, includes jets from #40 to #55; you furnish box
- Individual jets sold to dealer in five-packs; sold to consumer each



DS-289310

**CV-STYLE CARB; 90-06 BIG TWIN AND 88-06 XL**

PART #	DESCRIPTION	SUG. RETAIL (EA.)
DS289542	Master jet kit	\$207.95
DS-289315	#40 pilot jet (5-pk.)	4.75
DS-289316	#42 pilot jet (5-pk.)	4.75
DS-289317	#44 pilot jet (5-pk.)	4.75

PART #	DESCRIPTION	SUG. RETAIL (EA.)
DS-289318	#45 pilot jet (5-pk.)	\$4.75
DS-289319	#46 pilot jet (5-pk.)	4.75
DS-289320	#48 pilot jet (5-pk.)	4.75
DS289539	#50 pilot jet (5-pk.)	4.75

PART #	DESCRIPTION	SUG. RETAIL (EA.)
DS289540	#52 pilot jet (5-pk.)	\$4.75
DS289541	#54 pilot jet (5-pk.)	4.75
1005-0155	#55 pilot jet (5-pk.)	4.75

**BUTTERFLY-STYLE CARB; FOR 86-89 BIG TWIN AND 86-87 XL**

PART #	DESCRIPTION	SUG. RETAIL (EA.)
DS-289310	#50 pilot jet (5-pk.)	\$4.50
DS-289311	#52 pilot jet (5-pk.)	4.50
DS-289312	#54 pilot jet (5-pk.)	4.50
DS-289313	#56 pilot jet (5-pk.)	4.50
DS-289314	#58 pilot jet (5-pk.)	4.50

**A-BAX ENGINEERING KEIHIN STYLE PILOT JETS**

- Brass carburetor jets are high-precision flow-calibrated for extremely accurate fuel flow rate
- Available in a range of sizes
- High-quality replacement for Keihin style pilot jet N424-25B; NOT original Keihin jets
- Sold to dealer as 4-pack, sold to consumer as each



**A-BAX ENGINEERING PILOT JET ASSORTMENT FOR KEIHIN CV CARBURETORS**

- Brass carburetor pilot jets are high precision and flow-calibrated
- Kit includes one pilot jet the following sizes: 35, 38, 40, 42, 45, 48, 50, 52, 55, 58, 60, 62 and 65

PART #	DESCRIPTION	SUG. RETAIL
1005-0157	Pilot jet assortment	\$50.95



**A-BAX ENGINEERING MAIN JET ASSORTMENT FOR KEIHIN CV CARBURETORS**

- High-precision brass carburetor jets
- Jets are flow-calibrated for extremely accurate fuel flow rate
- Kit includes two jets of the following sizes: 160, 165, 170, 175, 180, 185, 190, 195, 200, 205, 210 and 220
- Replacement jets available in 2-pack



PART #	DESCRIPTION	SUG. RETAIL
<b>DEALER KIT</b>		
1006-0288	Main jet assortment	\$49.95
<b>JETS (2-PK.)</b>		
1006-0289	165 main jet (2-pk.)	5.00
1006-0290	170 main jet (2-pk.)	5.00

PART #	DESCRIPTION	SUG. RETAIL
<b>JETS (2-PK.) (CONT)</b>		
1006-0291	175 main jet (2-pk.)	\$5.00
1006-0292	180 main jet (2-pk.)	5.00
1006-0293	185 main jet (2-pk.)	5.00
1006-0294	190 main jet (2-pk.)	5.00

PART #	DESCRIPTION	SUG. RETAIL
<b>JETS (2-PK.) (CONT)</b>		
1006-0295	195 main jet (2-pk.)	\$5.00
1006-0296	200 main jet (2-pk.)	5.00
1006-0297	205 main jet (2-pk.)	5.00

**DISCLAIMER:** NOT LEGAL FOR SALE OR USE IN CALIFORNIA ON ANY POLLUTION CONTROLLED MOTOR VEHICLES. SEE PAGE 399 FOR IMPORTANT EMISSION DEFINITIONS AND REGULATORY COMPLIANCE AND WARRANTY INFORMATION.

All part numbers in **BLUE** are new for 2017.



WINDSHIELDS & FAIRINGS

AUDIO & VIDEO

SADDLEBAGS & LUGGAGE

SEATS & SISSY BARS

EXHAUST

FUEL/AIR SYSTEMS

ENGINE

TRANSMISSION & DRIVELINE

GASKETS & SEALS

ELECTRICAL

LIGHTING

HANDLEBARS, CONTROLS & MIRRORS

CABLES

BRAKES

TANKS & OIL FILTERS

DASHES & GAUGES

FRAMES & SUSPENSION

FENDERS & LICENSE PLATE FRAMES

FOOTRESTS

WHEELS & AXLES

HARDWARE, COVERS & GENERAL



**JET ASSORTMENT KITS AND REPLACEMENT PARTS FOR HSR42/HSR45/HSR48**

- HSR42 kit includes 150 through 170 main jets (2 each); 22.5 through 35 pilot jets (2 each); -96, -97 and -98 needles (1 each); 2 #60 a/p nozzles; needle clip; all necessary washers, special jet box
- HSR45 kit includes 165 through 185 main jets (2 each); 20 through 32.5 pilot jets (2 each); -95, -96 and -98 needles (1 each); 2 #60 a/p nozzles; 2 O-rings, 4 jet needle E-rings; all necessary washers
- HSR48 kit includes 180 through 210 main jets (2 each); 20 through 32.5 pilot jets (2 each); -95, -96 and -98 needles (1 each); 2 #60 a/p nozzles; 2 O-rings, 4 jet needle E-rings; all necessary washers
- Some kit components are available separately
- Made in Japan

PART #	DESCRIPTION	SUG. RETAIL
<b>JET KITS</b>		
KHS-025	HSR42	\$116.95
1007-0323	HSR45	116.95
1007-0322	HSR48	116.95
<b>INDIVIDUAL PARTS</b>		
1007-0324 <sup>1</sup>	Jet needle washers (4-pk.) for HSR45	.95

PART #	DESCRIPTION	SUG. RETAIL
<b>INDIVIDUAL PARTS (CONT)</b>		
1007-0327 <sup>1</sup>	O-rings (4-pk.) for HSR45	\$3.95
1007-0326 <sup>1</sup>	Pump nozzles (4-pk.) for HSR45/48	5.95
1007-0325 <sup>1</sup>	Needle jet E-rings (4-pk.) for HSR45/48	.95
1004-0010	-96 needle jet for HSR45/48	16.95
1004-0011	-98 needle jet for HSR45/48	16.95

<sup>1</sup> Sold to dealer as a 4-pk.; sold to consumer as each.

**GENUINE MIKUNI N100.604 MAIN JETS**

- N100.604 series main jets used in HSR and RS carburetors
- 8mm round head diameter, 9mm overall length
- Available in sizes 60-210
- Sold to dealer 4 per pack; sold to consumer as each
- Made in Japan

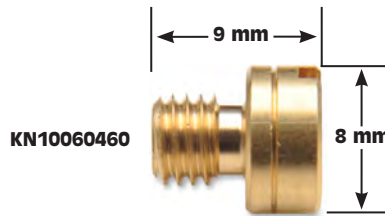

PART #	JET SIZE	SUG. RETAIL	PART #	JET SIZE	SUG. RETAIL	PART #	JET SIZE	SUG. RETAIL	PART #	JET SIZE	SUG. RETAIL
KN10060460	60	\$2.95	KN100604975	97.5	\$2.95	KN1006041375	137.5	\$2.95	KN100604175	175	\$2.95
KN100604625	62.5	2.95	KN100604100	100	2.95	KN100604140	140	2.95	KN1006041775	177.5	2.95
KN10060465	65	2.95	KN100604105	105	2.95	KN1006041425	142.5	2.95	KN100604180	180	2.95
KN100604675	67.5	2.95	KN1006041075	107.5	2.95	KN100604145	145	2.95	KN1006041825	182.5	2.95
KN10060470	70	2.95	KN100604110	110	2.95	KN1006041475	147.5	2.95	KN100604185	185	2.95
KN100604725	72.5	2.95	KN1006041125	112.5	2.95	KN100604150	150	2.95	KN1006041875	187.5	2.95
KN10060475	75	2.95	KN100604115	115	2.95	KN1006041525	152.5	2.95	KN100604190	190	2.95
KN100604775	77.5	2.95	KN1006041175	117.5	2.95	KN100604155	155	2.95	KN1006041925	192.5	2.95
KN10060480	80	2.95	KN100604120	120	2.95	KN1006041575	157.5	2.95	KN100604195	195	2.95
KN100604825	82.5	2.95	KN1006041225	122.5	2.95	KN100604160	160	2.95	KN100604200	200	2.95
KN10060485	85	2.95	KN100604125	125	2.95	KN1006041625	162.5	2.95	1006-0246	205	2.95
KN100604875	87.5	2.95	KN1006041275	127.5	2.95	KN100604165	165	2.95	1006-0247	210	2.95
KN10060490	90	2.95	KN100604130	130	2.95	KN1006041675	167.5	2.95			
KN100604925	92.5	2.95	KN1006041325	132.5	2.95	KN100604170	170	2.95			
KN10060495	95	2.95	KN100604135	135	2.95	KN1006041725	172.5	2.95			

**GENUINE MIKUNI VM22/210 PILOT JETS**

- These genuine Mikuni pilot jets fit most VM, TM and TMX carbs
- 4mm head diameter, 14mm overall length
- Sold to dealer in packs of 4; sold to consumer as each
- Made in Japan

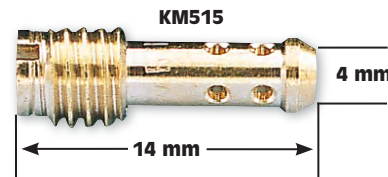

**GENUINE MIKUNI VM22/210 FOR ALL TM, TMX & VM CARBS**

PART #	JET SIZE	SUG. RETAIL	PART #	JET SIZE	SUG. RETAIL
KM515	15	\$2.95	KM545	45	\$2.95
KM520	20	2.95	KM550	50	2.95
KM525	25	2.95	KM555	55	2.95
1005-0011	27.5	2.95	KM560	60	2.95
KM530	30	2.95	KM565	65	2.95
1005-0010	32.5	2.95	KM570	70	2.95
KM535	35	2.95	KM575	75	2.95
KM540	40	2.95	KM580	80	2.95

**DISCLAIMER:** NOT LEGAL FOR SALE OR USE IN CALIFORNIA ON ANY POLLUTION CONTROLLED MOTOR VEHICLES. SEE PAGE 399 FOR IMPORTANT EMISSION DEFINITIONS AND REGULATORY COMPLIANCE AND WARRANTY INFORMATION.

All part numbers in **BLUE** are new for 2017.



**GENUINE MIKUNI 4/042 MAIN JETS**

**BRASS - LARGE HEX-TYPE**

- 6mm hex, 12mm overall length
- Fits most VM style carburetors
- Available in sizes 50-720
- Sold to dealer in packs of four; sold to consumer as each
- Made in Japan

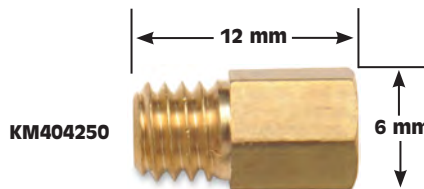

PART #	JET SIZE	SUG. RETAIL	PART #	JET SIZE	SUG. RETAIL	PART #	JET SIZE	SUG. RETAIL	PART #	JET SIZE	SUG. RETAIL
KM404250	50	\$2.95	KM4042140	140	\$2.95	KM4042260	260	\$2.95	KM4042440	440	\$2.95
KM404255	55	2.95	KM4042145	145	2.95	KM4042270	270	2.95	KM4042450	450	2.95
KM404260	60	2.95	KM4042150	150	2.95	KM4042280	280	2.95	KM4042460	460	2.95
KM404265	65	2.95	KM4042155	155	2.95	KM4042290	290	2.95	KM4042470	470	2.95
KM404270	70	2.95	KM4042160	160	2.95	KM4042300	300	2.95	KM4042480	480	2.95
KM404275	75	2.95	KM4042165	165	2.95	KM4042310	310	2.95	KM4042490	490	2.95
KM404280	80	2.95	KM4042170	170	2.95	KM4042320	320	2.95	KM4042500	500	2.95
KM404285	85	2.95	KM4042175	175	2.95	KM4042330	330	2.95	KM4042540	540	2.95
KM404290	90	2.95	KM4042180	180	2.95	KM4042340	340	2.95	KM4042560	560	2.95
KM404295	95	2.95	KM4042185	185	2.95	KM4042350	350	2.95	KM4042580	580	2.95
KM4042100	100	2.95	KM4042190	190	2.95	KM4042360	360	2.95	KM4042600	600	2.95
KM4042105	105	2.95	KM4042195	195	2.95	KM4042370	370	2.95	KM4042620	620	2.95
KM4042110	110	2.95	KM4042200	200	2.95	KM4042380	380	2.95	KM4042640	640	2.95
KM4042115	115	2.95	KM4042210	210	2.95	KM4042390	390	2.95	KM4042660	660	2.95
KM4042120	120	2.95	KM4042220	220	2.95	KM4042400	400	2.95	KM4042680	680	2.95
KM4042125	125	2.95	KM4042230	230	2.95	KM4042410	410	2.95	KM4042700	700	2.95
KM4042130	130	2.95	KM4042240	240	2.95	KM4042420	420	2.95	KM4042720	720	2.95
KM4042135	135	2.95	KM4042250	250	2.95	KM4042430	430	2.95			



**GENUINE MIKUNI VM28/486 SERIES PILOT JETS**

- Fits HSR and RS Mikuni carburetors
- Available in sizes 15-60
- Sold to dealer as 4-pack; sold to consumer as each
- Made in Japan

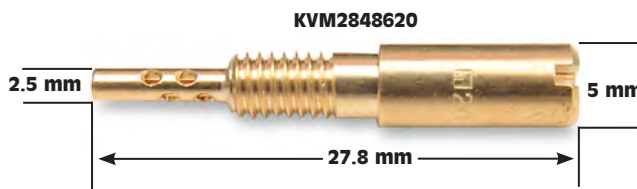

PART #	JET SIZE	SUG. RETAIL	PART #	JET SIZE	SUG. RETAIL	PART #	JET SIZE	SUG. RETAIL
KVM2848615	15	\$2.95	KVM28486275	27.5	\$2.95	KVM2848645	45	\$2.95
KVM28486175	17.5	2.95	KVM2848630	30	2.95	KVM2848650	50	2.95
KVM2848620	20	2.95	1005-0012	32.5	2.95	KVM2848655	55	2.95
KVM28486225	22.5	2.95	KVM2848635	35	2.95	KVM2848660	60	2.95
KVM2848625	25	2.95	KVM2848640	40	2.95			



**A-BAX PILOT JETS FOR MIKUNI VM28/486**

- Fit all RS, HS and HSR carburetors
- 28.1mm long
- Sold to dealer as 4-pack; sold to consumer as each



PART #	JET SIZE	SUG. RETAIL	PART #	JET SIZE	SUG. RETAIL	PART #	JET SIZE	SUG. RETAIL
1005-0047	10	\$3.25	1005-0056	32.5	\$3.25	1005-0065	55	\$3.25
1005-0048	12.5	3.25	1005-0057	35	3.25	1005-0066	57.5	3.25
1005-0049	15	3.25	1005-0058	37.5	3.25	1005-0067	60	3.25
1005-0050	17.5	3.25	1005-0059	40	3.25	1005-0068	62.5	3.25
1005-0051	20	3.25	1005-0060	42.5	3.25	1005-0069	65	3.25
1005-0052	22.5	3.25	1005-0061	45	3.25	1005-0070	67.5	3.25
1005-0053	25	3.25	1005-0062	47.5	3.25	1005-0071	70	3.25
1005-0054	27.5	3.25	1005-0063	50	3.25			
1005-0055	30	3.25	1005-0064	52.5	3.25			



**GENUINE MIKUNI JET NEEDLES FOR HSR42/45/48 CARBURETORS**

- Genuine Mikuni jet needles
- Needles are available in a variety of sizes to suit most applications
- Sold each
- Made in Japan



HSR42	HSR45/48	DESCRIPTION	SUG. RETAIL	HSR42	HSR45/48	DESCRIPTION	SUG. RETAIL
J8-8DDY01-95	J8-8CFY02-95	Richest	\$11.95	J8-8DDY01-97	J8-8CFY02-97	Standard	\$11.95
J8-8DDY01-96	J8-8CFY02-96	Richer	11.95	J8-8DDY01-98	J8-8CFY02-98	Leaner	11.95

**DISCLAIMER:** NOT LEGAL FOR SALE OR USE IN CALIFORNIA ON ANY POLLUTION CONTROLLED MOTOR VEHICLES. SEE PAGE 399 FOR IMPORTANT EMISSION DEFINITIONS AND REGULATORY COMPLIANCE AND WARRANTY INFORMATION.

All part numbers in BLUE are new for 2017.

WINDSHIELDS & FAIRINGS

AUDIO & VIDEO

SADDLEBAGS & LUGGAGE

SEATS & SISSY BARS

EXHAUST

FUEL/AIR SYSTEMS

ENGINE

TRANSMISSION & DRIVELINE

GASKETS & SEALS

ELECTRICAL

LIGHTING

HANDLEBARS, CONTROLS & MIRRORS

CABLES

BRAKES

TANKS & OIL FILTERS

DASHES & GAUGES

FRAMES & SUSPENSION

FENDERS & LICENSE PLATE FRAMES

FOOTRESTS

WHEELS & AXLES

HARDWARE, COVERS & GENERAL

WINDSHIELDS & FAIRINGS

AUDIO & VIDEO

SADDLEBAGS & LUGGAGE

SEATS & SISSY BARS

EXHAUST

FUEL/AIR SYSTEMS

ENGINE

TRANSMISSION & DRIVELINE

GASKETS & SEALS

ELECTRICAL

LIGHTING

HANDLEBARS, CONTROLS & MIRRORS

CABLES

BRAKES

TANKS & OIL FILTERS

DASHES & GAUGES

FRAMES & SUSPENSION

FENDERS & LICENSE PLATE FRAMES

FOOTRESTS

WHEELS & AXLES

HARDWARE, COVERS & GENERAL



**POWER X-WING**

- Patented air vane requires no modifications to install
- Acceleration gains from idle to wide-open throttle
- Dyno tests show 2-5 horsepower gains and 4-6 ft.-lbs. max torque increases on OEM H-D engines
- Independent tests were conducted on 88", 96" and 110" engines
- Complements popular air filter system upgrades
- Made in the U.S.A.

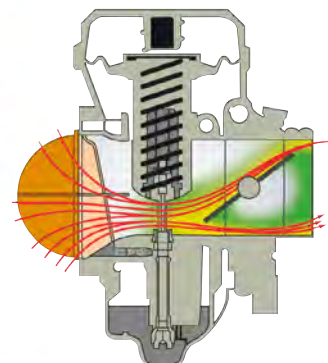

1050-0180

PART #	DESCRIPTION	SUG. RETAIL
1050-0194	For 08-15 FLHT/FLHX/FLHR/FLTR models	\$129.95
1050-0182	For 06-15 Softail/Dyna, 06-07 FLHT/FLHX/FLHR/FLTR w/ Delphi EFI	129.95
1050-0181	For 01-05 Softail, 04-05 Dyna, 02-05 FLHT/FLHR/FLTR, 07-15 XL w/ Delphi EFI	129.95
1050-0180	For 88-06 models w/ OEM CV carb	129.95
1050-0237	For 02-15 V-Rod models	179.95

PART #	DESCRIPTION	SUG. RETAIL
1050-0236	For 03-09 Buell XB12 models	\$129.95
1050-0195	For Mikuni HSR 42/45 carbs w/ early style 1.75" H-D adapter	129.95
1050-0196	For Mikuni HSR 42/45 carbs w/ late style 2" H-D adapter	129.95
1050-0197	For Mikuni HSR 48 carb w/ 2" adapter	129.95
1050-0205	For S&S Super E Shorty	129.95

**FLANGE MOUNT INTAKE MANIFOLDS**

- For mounting an S&S E and G series carburetor or flange mount carburetor on a 99-06 Twin Cam motor with S&S or stock cylinder heads
- Will also fit a 84-99 80" Evolution that requires a manifold with a map sensor port
- Come with a map sensor port and match OEM intake ports
- Made in the U.S.A.



1050-0046

**FLANGE-MOUNT INTAKE MANIFOLDS**

- Can be used to replace stock "compliance fitting" manifold on 84-89 and stock rigid-mount manifold from 90-99
- Use with stock or S&S cylinder heads
- For use with stock 5.5550" length cylinders
- Requires the use of S&S intake seals and flanges (sold separately)
- Made in the U.S.A.



PART #	DESCRIPTION	SUG. RETAIL
1050-0291	S&S E-series intake manifold	\$95.95
1050-0046	S&S G-series intake manifold	95.95

PART #	DESCRIPTION	SUG. RETAIL
<b>FOR 84-99 EVOLUTION-STYLE BIG TWIN</b>		
1050-0110	For Super G carbs (no MAP sensor port)	\$95.95
1050-0293	For Super E carbs (no MAP sensor port)	95.95

**MANIFOLD CONVERSION KIT FOR 80" EVOLUTION**

- Kit converts stock 80" Evolution manifold to a more rigid-mount system
- Eliminates cracking and leaking problems associated with the stock rubber compliance fittings
- Includes an S&S Performance manifold, mounting flanges, two specially molded O-rings and two .350" spacers for spacing out the stock air cleaner or carb mount bracket
- Fits 84-99 80" models if flange-type carburetor or adapter is used
- Replacement flange seals also available
- Made in the U.S.A.



NOTE: Not for use with an S&S G series carb.

PART #	DESCRIPTION	SUG. RETAIL
1050-0296	Manifold conversion kit	\$116.95



**MANIFOLD CONVERSION KIT FOR SPORTSTER**

- Replaces original rubber manifold
- Size 341 fits 4,650" cylinders
- Natural finish
- Includes front and rear manifold mounting flanges, manifold O-rings and aluminum spacer shims



1050-0353

PART #	DESCRIPTION	SUG. RETAIL
<b>FOR 86-03 XL MODELS</b>		
1050-0353	Kit for Super B, E, ES, LS, Tillotson, Bendix and Keihin carbs	\$110.95
1050-0352	Repl. manifold only for kit	95.95

**SPIGOT-MOUNT INTAKE MANIFOLDS FOR S&S HEADS**

- Used to install a stock CV carburetor on S&S 3.625", 4" and 4.125" bore motors
- Will also fit S&S Hot Setup and Super Stock™ head kits
- PART #1050-0295 is used to install 48 mm CV or Mikuni carburetor on Twin Cam 88", 95" bore motors
- Made in the U.S.A.

NOTE: Not for use with OEM-style O-rings, requires the use of S&S manifold O-rings and U-rings, sold separately.



1050-0292



PART #	ENGINE SIZE	CYLINDER LENGTH	SUG. RETAIL
<b>FOR S&amp;S TWIN CAM STYLE MOTORS AND HEAD KITS</b>			
1050-0292	88"/95"/96"	4.9365"	\$110.95
1050-0295	88"/95"/96"	4.9365"	118.95

PART #	ENGINE SIZE	CYLINDER LENGTH	SUG. RETAIL
<b>FOR S&amp;S BIG TWIN EVOLUTION STYLE MOTORS AND HEAD KITS</b>			
1050-0294	80"/89"/96"	5.550"	\$110.95

**DISCLAIMER:** NOT LEGAL FOR SALE OR USE IN CALIFORNIA ON ANY POLLUTION CONTROLLED MOTOR VEHICLES. SEE PAGE 399 FOR IMPORTANT EMISSION DEFINITIONS AND REGULATORY COMPLIANCE AND WARRANTY INFORMATION.

All part numbers in BLUE are new for 2017.

1003-0313



0934-0665



**INTAKE MANIFOLD O-RINGS AND U-RINGS**

- For use with all current S&S intake manifolds
- O-rings sold in 10-pack
- U-rings sold each
- Made in the U.S.A.



PART #	DESCRIPTION	SUG. RETAIL (EA.)
<b>O-RINGS (MANIFOLD TO CYLINDER HEADS)</b>		
1003-0060	For 84-06 Big Twin and 86-06 Sportster engines w/ S&S manifold (10-pk.)	\$4.95
1003-0313	For stock heads (OEM #26995-86A) (10-pk.)	3.95
<b>U-RINGS (CV CARB TO MANIFOLD)</b>		
0934-0666	40-42mm	21.95
0934-0665	44-45mm	15.95



M-VM-40-200



**RUBBER FLANGE ADAPTERS FOR SPIGOT-TYPE CARBURETORS**

- Adapters fit 38mm and 40mm spigot-type carburetors
- Includes clamp
- PART # M-VM-36-200 has mounting holes that are 70mm on center; ID of 39.5mm
- PART # M-VM-38-200 has mounting holes that are 74.6mm on center; ID of 38mm
- PART # M-VM-40-200 has mounting holes that are 74.6mm on center; ID of 47mm
- Sold individually
- Made in Japan

PART #	DESCRIPTION	SUG. RETAIL
M-VM-36-200	36mm-38mm rubber flange adapter	\$23.95
M-VM-38-200	40mm rubber flange adapter - 43mm carb spigot OD (fits RS40, RS42)	23.95
M-VM-40-200	40mm rubber flange adapter - 52mm carb spigot OD	23.95



**CHROME INTAKE MANIFOLD FLANGES**

- Chrome flanges replace the stock flanges
- Sold in pairs
- Replacement intake manifold seals also available; see GASKETS & SEALS section



PART #	DESCRIPTION	SUG. RETAIL
DS-289212	For 90-05 Big Twin and 86-06 XL models	\$25.95

1022-0068



**INTAKE FLANGES**

- CNC-machined 6061 billet aluminum construction
- Will not crack or warp like some forged flanges
- Includes seals
- Made in the U.S.A.

PART #	DESCRIPTION	SUG. RETAIL
1022-0068	For 06-17 Twin Cam models	\$61.95
1022-0069	For 01-05 Big Twin models	61.95



**BILLET FLANGE ADAPTER FOR SPIGOT-TYPE CARBS**

- Allows you to mount OEM late-model CV or Mikuni HSR-42 carbs on early Evolutions with two-bolt flange manifolds
- CNC machined from 6061 billet aluminum
- Mounting holes are 2.75" on center
- Can be polished, plated or painted
- Carb-to-manifold seal also available; see GASKETS & SEALS section
- Sold each
- Made in the U.S.A.

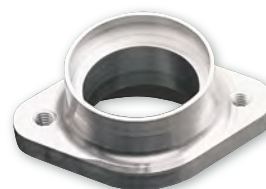

PART #	DESCRIPTION	SUG. RETAIL
DS-289219	Billet flange adapter	\$29.95



**BLACK FLANGE ADAPTERS**

- Rubber flange adapters fit 42mm, 45mm and 48mm spigot-type carburetors
- PART # HS42/018-42 has mounting holes that are 70mm on center; ID of 45mm
- PART # HS42/018-45 has mounting holes that are 70mm on center; ID of 48mm
- PART # HS42/062-48 has mounting holes that are 70mm on center; ID of 71mm
- Includes clamp
- Original straight-through design
- Sold individually
- Made in Japan



HS42/062-48

PART #	DESCRIPTION	SUG. RETAIL
HS42/018-42	42mm	\$31.95
HS42/018-45	45mm	31.95
HS42/062-48	48mm	31.95



1050-0232

1003-0060

**INTAKE MANIFOLD FLANGES**

- Sold in pair (front/rear)
- Replacement seals also available
- Made in the U.S.A.



PART #	DESCRIPTION	SUG. RETAIL
<b>FOR 84-05 BIG TWIN AND 86-06 SPORTSTER ENGINES WITH S&amp;S INTAKE MANIFOLD</b>		
1050-0232	Front/rear flange; repl. H-D #27009-86B and #27010-86B	\$34.95 (pr.)
1003-0060	Repl. seals (10-pk)	4.95 (ea.)



**ENGINE BREATHERS**

- Chromed, CNC-machined 6061 billet aluminum crankcase breathers screw directly into cylinder heads
- Allow a clean, simple way for the engine to "breathe" correctly
- Made in the U.S.A.



PART #	DESCRIPTION	SUG. RETAIL
2106-1001	For all 93-99 Evolution Big Twin and 91-17 XL	\$99.95

**DISCLAIMER:** NOT LEGAL FOR SALE OR USE IN CALIFORNIA ON ANY POLLUTION CONTROLLED MOTOR VEHICLES. SEE PAGE 399 FOR IMPORTANT EMISSION DEFINITIONS AND REGULATORY COMPLIANCE AND WARRANTY INFORMATION.

All part numbers in BLUE are new for 2017.

WINDSHIELDS & FAIRINGS

AUDIO & VIDEO

SADDLEBAGS & LUGGAGE

SEATS & SISSY BARS

EXHAUST

FUEL/AIR SYSTEMS

ENGINE

TRANSMISSION & DRIVELINE

GASKETS & SEALS

ELECTRICAL

LIGHTING

HANDLEBARS, CONTROLS & MIRRORS

CABLES

BRAKES

TANKS & OIL FILTERS

DASHES & GAUGES

FRAMES & SUSPENSION

FENDERS & LICENSE PLATE FRAMES

FOOTRESTS

WHEELS & AXLES

HARDWARE, COVERS & GENERAL

WINDSHIELDS & FAIRINGS  
AUDIO & VIDEO  
SADDLEBAGS & LUGGAGE  
SEATS & SISSY BARS

EXHAUST

FUEL/AIR SYSTEMS

ENGINE

TRANSMISSION & DRIVELINE

GASKETS & SEALS

ELECTRICAL

LIGHTING

HANDLEBARS, CONTROLS & MIRRORS

CABLES

BRAKES

TANKS & OIL FILTERS

DASHES & GAUGES

FRAMES & SUSPENSION

FENDERS & LICENSE PLATE FRAMES

FOOTRESTS

WHEELS & AXLES

HARDWARE, COVERS & GENERAL



1012-0095



1012-0143



1012-0145



**SUPPORT BRACKET/BREATHER KITS**

- Billet aluminum construction with a chrome, black or wrinkle-black finish
- Crankcase breathes back into the carb or throttle body so no external lines are necessary
- Allow custom air cleaners or velocity stacks to be installed in a horizontal or vertical position; no other adapters are required
- Include installation hardware
- Made in the U.S.A.



1012-0148



1012-0137

PART #	DESCRIPTION	SUG. RETAIL
<b>FOR 17 FXDLS, 16-17 SOFTTAILS, 08-16 FLHT/FLHR/FLHX/FLTR/FLHTCUTG/FLHXXX</b>		
1012-0095	Chrome	\$247.95
<b>FOR 93-06 BIG TWIN W/ 40MM CV CARB AND 01-17 BIG TWIN W/ DELPHI EFI (EXCEPT 17 FXDLS, 16-17 SOFTTAILS, 08-17 DRESSER)</b>		
1012-0142	Chrome	188.95
1012-0143	Black	188.95
1012-0144	Wrinkle black	188.95
<b>FOR 93-99 EVOLUTION BIG TWIN W/ S&amp;S E OR G CARB</b>		
1012-0145 <sup>1</sup>	Chrome	188.95

PART #	DESCRIPTION	SUG. RETAIL
<b>FOR 93-99 EVOLUTION BIG TWIN W/ S&amp;S E OR G CARB (CONT)</b>		
1012-0146 <sup>1</sup>	Black	\$188.95
<b>FOR 93-06 BIG TWIN W/ MIKUNI 42/45/48 CARB</b>		
1012-0148	Chrome	198.95
1012-0149	Black	198.95
<b>FOR 91-17 XL W/ CV CARB OR DELPHI EFI</b>		
1012-0137	Chrome	207.95
1012-0138	Black	207.95

<sup>1</sup> Not for 100" S&S motors.



**SUPPORT BRACKET WITH BREATHER SYSTEM**

- Billet aluminum with chrome finish
- Clean, one-piece design support bracket with internal breather system
- Crankcase breathes back into the carb or throttle body so no external lines are necessary
- Accepts most CV/Delphi EFI-style air cleaners
- Includes installation hardware
- Made in the U.S.A.



1012-0082

PART #	DESCRIPTION	SUG. RETAIL
<b>FOR 99-17 TWIN CAM (EXCEPT 17 FXDLS, 16-17 SOFTTAILS, 08-17 DRESSER)</b>		
1012-0080	For S&S E/G carb, Twin Cam	\$304.95
1012-0082	For CV carb/Delphi EFI Twin Cam	304.95

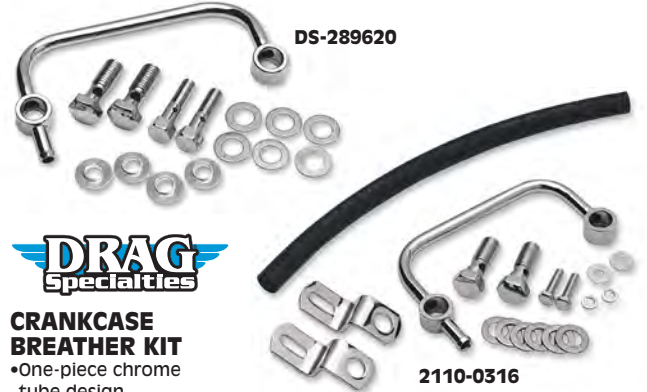

DS-289620

2110-0316

**CRANKCASE BREATHER KIT**

- One-piece chrome tube design
- Comes with breather bolts, washers and hardware
- Works with most aftermarket air cleaners

PART #	DESCRIPTION	SUG. RETAIL
DS-289620	For 93-17 Big Twin (except 17 FXDLS, 16-17 Softails, 08-17 Dressers)	\$32.95
2110-0316	For 91-17 XL	29.95



**HSR CARBURETOR HEAD-BREATHER KITS**

- For use with Mikuni air filter PART #HS42012250 and HS42012300
- For the installation of HSR carburetor kits using the K&N high-flow filter on Evo and Twin Cam Big Twins

PART #	DESCRIPTION	SUG. RETAIL
KHS-020	For HSR42/45 carb on Evo Big Twin	\$85.95
KHS-030	For HSR42/45 carb on Twin Cam	85.95



**DISCLAIMER:** NOT LEGAL FOR SALE OR USE IN CALIFORNIA ON ANY POLLUTION CONTROLLED MOTOR VEHICLES. SEE PAGE 399 FOR IMPORTANT EMISSION DEFINITIONS AND REGULATORY COMPLIANCE AND WARRANTY INFORMATION.

All part numbers in **BLUE** are new for 2017.



**CRANKCASE BREATHER/SUPPORT BRACKET KITS**

- Kit allows the installation of aftermarket air cleaner assemblies on late model bikes equipped with OEM CV carb or Delphi EFI system
- Includes bracket, filter, hose and all mounting hardware necessary for installation except where noted



PART #	DESCRIPTION	SUG. RETAIL
<b>1013-0036</b>	For 17 FXDLS, 16-17 Softails, 08-16 FLHT/FLTR/FLHX/FLHR models	<b>\$74.95</b>
<b>DS-289082</b>	For all 93-17 Big Twin models (except 17 FXDLS, 16-17 Softails, 08-17 Dressers)	<b>69.95</b>

PART #	DESCRIPTION	SUG. RETAIL
<b>DS-289060</b>	For 93-17 Big Twin models (no hose or filter) (except 17 FXDLS, 16-17 Softails, 08-17 Dressers)	<b>\$64.95</b>
<b>1013-0030</b>	For 07-17 XL models	<b>69.95</b>
<b>DS-289126</b>	For 91-06 XL models	<b>64.95</b>
<b>DS-289073</b>	Repl. filter	<b>12.95</b>



**BRAIDED HOSE CRANKCASE BREATHER KIT**

- This kit provides the best looking alternative to black rubber hoses when mounting a crankcase breather system
  - Features a 3/8" i.d. stainless steel braided hose crimped onto chrome banjo fittings
  - Outlet side of assembly is long enough to custom-route the hose and mount the breather filter in an inconspicuous location
  - Includes breather filter (with mounting stud), hardware and instructions
  - Air cleaner and carb support bracket must be purchased separately
- NOTE: Not recommended for stock applications. Make sure the braided line does not contact anything (i.e. the gas tank, carb or wiring) as damage may result.**



**AIR CLEANER BREATHER KIT**

- Enables the mounting of most aftermarket air cleaners to late-style engines that breathe through the cylinder heads
- Fittings can be rotated 360° so that hoses can be routed as necessary
- Hose sold separately



PART #	DESCRIPTION	SUG. RETAIL
<b>DS289118</b>	For 93-17 Big Twin custom applications only	<b>\$79.95</b>

PART #	DESCRIPTION	SUG. RETAIL
<b>DS-289055</b>	For 93-17 Big Twin (except 17 Dressers) and 91-17 XL models	<b>\$49.95</b>

**KURYAKYN**

**CHROME CRANKCASE BREATHER**

- With this breather, as oil-laden air condenses in the breather body, the excess oil now runs back down into the engine rather than into the air cleaner
- A really clean setup

**NOTE: Not for use on fuel-injected models.**

PART #	DESCRIPTION	SUG. RETAIL
<b>1012-0200</b>	For 07-17 XL	<b>\$36.99</b>

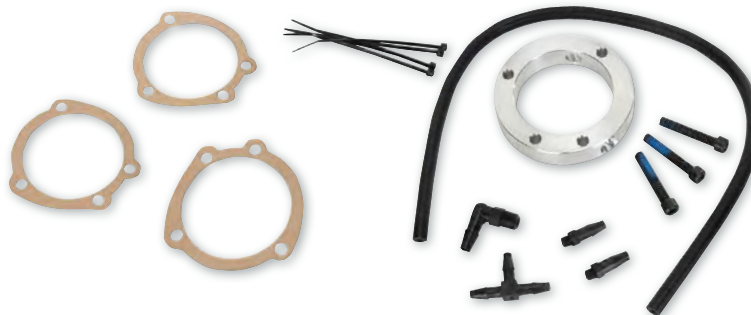

**KURYAKYN**

**BLUEGRASS BREATHER KITS**

- Kits route the vented gases upward so gravity can keep any expelled oil droplets back into the engine instead of down the sides of the bike
- Vent line can be run up or out, into an optional catch tank (available separately, PART #1012-0217)
- Include vent hose and fittings

PART #	DESCRIPTION	SUG. RETAIL
<b>1012-0218</b>	Short leg breather kit for 93-99 Evo Big Twin (most carbs except Mikuni HSR), 99-06 Twin Cam with stock and most carbs, 01-17 Twin Cam with Delphi EFI (except 17 FXDLS, 16-17 Softails, 08-17 Touring/Trike and 11-12 FLTSE, 13-14 FXSBSE and 14-15 FLTNSSE)	<b>\$54.99</b>
<b>1012-0216</b>	Long leg breather kit for 93-99 Evo Big Twin with Mikuni HSR series carb, 91-17 XL Models	<b>54.99</b>
<b>1012-0217</b>	Optional catch tank for breather kits	<b>51.99</b>



**DISCLAIMER:** NOT LEGAL FOR SALE OR USE IN CALIFORNIA ON ANY POLLUTION CONTROLLED MOTOR VEHICLES. SEE PAGE 399 FOR IMPORTANT EMISSION DEFINITIONS AND REGULATORY COMPLIANCE AND WARRANTY INFORMATION.

All part numbers in **BLUE** are new for 2017.

WINDSHIELDS & FAIRINGS

AUDIO & VIDEO

SADDLEBAGS & LUGGAGE

SEATS & SISSY BARS

EXHAUST

FUEL/AIR SYSTEMS

ENGINE

TRANSMISSION & DRIVELINE

GASKETS & SEALS

ELECTRICAL

LIGHTING

HANDLEBARS, CONTROLS & MIRRORS

CABLES

BRAKES

TANKS & OIL FILTERS

DASHES & GAUGES

FRAMES & SUSPENSION

FENDERS & LICENSE PLATE FRAMES

FOOTRESTS

WHEELS & AXLES

HARDWARE, COVERS & GENERAL



WINDSHIELDS & FAIRINGS

AUDIO & VIDEO

SADDLEBAGS & LUGGAGE

SEATS & SISSY BARS

EXHAUST

FUEL/AIR SYSTEMS

ENGINE

TRANSMISSION & DRIVELINE

GASKETS & SEALS

ELECTRICAL

LIGHTING

HANDLEBARS, CONTROLS & MIRRORS

CABLES

BRAKES

TANKS & OIL FILTERS

DASHES & GAUGES

FRAMES & SUSPENSION

FENDERS & LICENSE PLATE FRAMES

FOOTRESTS

WHEELS & AXLES

HARDWARE, COVERS & GENERAL



1012-0017

**3 1/4" CUT-TO-LENGTH CHROME BUTTON-HEAD BREATHER BOLT KITS**

- Solve the problem when mounting a carb support bracket
- Sold in pairs
- Made in the U.S.A.

PART #	DESCRIPTION	SUG. RETAIL
1012-0017	3/8"-16 w/ 1/2" inserts	\$67.95
1012-0018	3/8"-16	67.95
1012-0019	5/16"-18	67.95

**RADIUS BREATHER BOLTS**

- Innovative design with five-ply sintered stainless steel mesh, providing the proper breathability for your motor while keeping a slim profile and a completely custom look
- An internally broached Allen allows for a quick and hidden installation method, with the stainless breather element and circlip finishing the job
- A perfect match with your choice of air cleaner and carb support brackets
- Available in chrome-plated or black electroplated steel
- Sold in pairs
- Made in the U.S.A.

PART #	DESCRIPTION	SUG. RETAIL
<b>FOR 99-17 TWIN CAM (3/8"-16 THREAD)</b>		
1012-0203	Black electroplated	\$44.95
1012-0205	Chrome	44.95

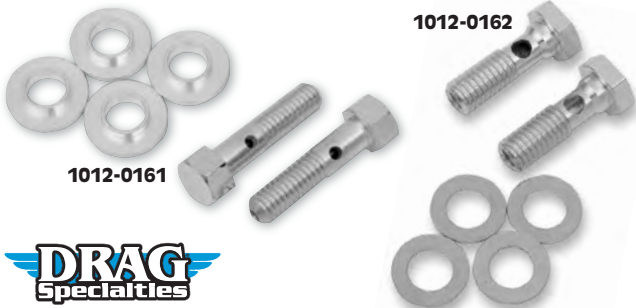

1012-0162

1012-0161



**TWIN CAM/EVOLUTION BREATHER BOLT KITS**

- Chrome-plated hex-head breather bolts
- Fit most supports and breather brackets
- Include sealing washers

PART #	DESCRIPTION	SUG. RETAIL
1012-0161	3/8"-16 (Twin cam)	\$16.95
1012-0162	1/2"-13 (Evolution)	16.95



**BREATHER BOLT COVERS**

- Hide the zinc breather bolts with these chrome-plated covers
- Quick, easy upgrade; just press on and tighten the setscrew

PART #	DESCRIPTION	SUG. RETAIL
1012-0169	For 99-17 Twin Cam, 07-17 XL w/ Kuryakyn air cleaners and crankcase breather kits	\$19.99

**DISCLAIMER:** NOT LEGAL FOR SALE OR USE IN CALIFORNIA ON ANY POLLUTION CONTROLLED MOTOR VEHICLES. SEE PAGE 399 FOR IMPORTANT EMISSION DEFINITIONS AND REGULATORY COMPLIANCE AND WARRANTY INFORMATION.

All part numbers in **BLUE** are new for 2017.

1012-0039



1012-0038



**BREATHER BOLT KITS**

- Chrome-plated button-head bolts fit most support brackets and breathers
- Kit for 93-99 Evolution-style engines comes with two 1/2"-13 x 1 3/4" bolts, four thick aluminum washers and four stainless steel washers
- Kit for 99-16 Twin Cam-style engines comes with two 3/8"-16 x 1 3/4" coarse-thread bolts, six stepped aluminum washers and four stainless steel washers
- Made in the U.S.A.

PART #	DESCRIPTION	SUG. RETAIL
1012-0039	For 99-17 Twin Cam	\$50.95
1012-0038	For 93-99 Evolution	40.95



1012-0203



1012-0205



PART #	DESCRIPTION	SUG. RETAIL
<b>FOR 93-99 EVOLUTION BIG TWIN AND 91-17 XL (1/2"-13 THREAD)</b>		
1012-0202	Black electroplated	\$44.95
1012-0204	Chrome	44.95

**BREATHER BOLT WASHER KIT**

- Features four 1/2" and four 5/16" aluminum centering washers
- Also includes four 1/2" nylon sealing washers



PART #	DESCRIPTION	SUG. RETAIL
1012-0005	For 91-17 breather systems	\$8.95



**THREAD REDUCER**

- Used on 93-99 H-D cylinder heads when installing a carburetor support bracket that requires 5/16"-18 mounting bolts
- Reduces a 1/2"-13 threaded hole to 5/16"-18
- Sold each; two required per motor
- Made in the U.S.A.



PART #	DESCRIPTION	SUG. RETAIL
7806-2940	1/2"-13 to 5/16"-18 thread reducer	\$5.95



**BREATHER TUBES**

- For use with OEM backing plates and air filters
- Sold in pairs

PART #	DESCRIPTION	SUG. RETAIL
1010-2029	For 93-98 Touring/Dyna Glide models, 93-99 Softail models and 95-00 XL models; repl. OEM # 24922-93	\$13.95

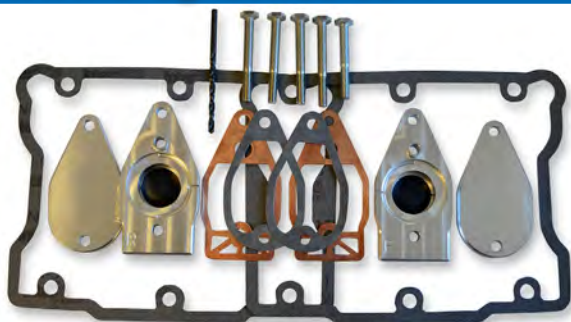

**MYSTFREE KIT**

- Machined T-6061 billet aluminum construction
- Helps oil drain more efficiently into the rocker
- Reduces oil misting coming from the engine breathers
- Made in the U.S.A.



PART #	DESCRIPTION	SUG. RETAIL
0920-0118	For 99-16 FL Touring, 00-17 Softail/Dyna models	\$229.95



**CARB SUPPORT BRACKET WITH CHOKE CABLE MOUNT**

- Chrome-plated stamped steel
- Provides support for carb and air cleaner
- Offers mounting of choke control under the carb for easy access

PART #	DESCRIPTION	SUG. RETAIL
2110-1212	For 92-06 Big Twin w/ Mikuni HSR 42/45 carb	\$39.95



**SUPPORT BRACKETS**

- Chrome air cleaner braces provide additional support for the Dragtron™ II air cleaners or any flat-backed air cleaners
- Mount to the cylinder heads
- Can be used in conjunction with most breather kits (where applicable)
- Breather kits/bolts sold separately
- All gaskets and mounting hardware included
- For replacement gaskets, see GASKETS & SEALS section



PART #	DESCRIPTION	SUG. RETAIL
DS289190	For 90-17 Big Twin (except 17 FXDLS, 16-17 Softails, 08-17 Dressers) (CV carb/Delphi EFI)	\$33.95
DS-289053	For 84-89 Big Twin Evolution (butterfly carb)	24.95
1013-0017	For 07-17 XL	29.95
DS-289062	For 88-06 XL	24.95

**DISCLAIMER:** NOT LEGAL FOR SALE OR USE IN CALIFORNIA ON ANY POLLUTION CONTROLLED MOTOR VEHICLES. SEE PAGE 399 FOR IMPORTANT EMISSION DEFINITIONS AND REGULATORY COMPLIANCE AND WARRANTY INFORMATION.

All part numbers in BLUE are new for 2017.



**BREATHER SHOP SERVICE KIT**

- Includes all gaskets, seals and O-rings to service OEM breather systems
- Made in the U.S.A.



PART #	DESCRIPTION	SUG. RETAIL
0934-0942	Breather service kit	\$10.95



**CV CARB SUPPORT BRACKET**

- Provides additional support for the carb and air cleaner
- Black powder-coated steel
- Made in the U.S.A.

NOTE: Breather kits/bolts sold separately.

PART #	DESCRIPTION	SUG. RETAIL
1013-0105	For 93-99 Evolution Big Twin model w/ CV carb	\$34.95
1013-0103	For 91-06 XL model w/ CV carb	34.95
1013-0109	For 91-06 XL model w/ S&S carb	34.95



**THROTTLE BODY SUPPORT BRACKET COVER**

- Adds a chrome accent to the OEM support bracket
- A must-have when replacing the OEM air cleaner



PART #	DESCRIPTION	SUG. RETAIL
1013-0073	For 17 FXDLS, 16-17 Softails, 08-16 FLHT/FLHR/FLTR/FLHX and H-D FL Trikes	\$49.99

**ADJUSTABLE CARBURETOR SUPPORT BRACKET**



- Adjusts from 5.25" to 6.375"
- Mounts from the center-case bolt between cylinders to the lower flange mount of the manifold
- Made in the U.S.A.



PART #	DESCRIPTION	SUG. RETAIL
160471	Support bracket	\$17.95



**CARB SUPPORT**

- Simple carb support bolts directly to lower the intake bolt and the center case stud; also allows for fuel line to pass through keeping it off the cylinders
- Made from stainless steel with a tumbled finish
- Made in the U.S.A.



PART #	DESCRIPTION	SUG. RETAIL
1050-0363	Carb support for S&S carburetor	\$21.95

WINDSHIELDS & FAIRINGS

AUDIO & VIDEO

SADDLEBAGS & LUGGAGE

SEATS & SISSY BARS

EXHAUST

FUEL/AIR SYSTEMS

ENGINE

TRANSMISSION & DRIVELINE

GASKETS & SEALS

ELECTRICAL

LIGHTING

HANDLEBARS, CONTROLS & MIRRORS

CABLES

BRAKES

TANKS & OIL FILTERS

DASHES & GAUGES

FRAMES & SUSPENSION

FENDERS & LICENSE PLATE FRAMES

FOOTRESTS

WHEELS & AXLES

HARDWARE, COVERS & GENERAL

- WINDSHIELDS & FAIRINGS
- AUDIO & VIDEO
- SADDLEBAGS & LUGGAGE
- SEATS & SISSY BARS
- EXHAUST
- FUEL/AIR SYSTEMS**
- ENGINE
- TRANSMISSION & DRIVELINE
- GASKETS & SEALS
- ELECTRICAL
- LIGHTING
- HANDLEBARS, CONTROLS & MIRRORS
- CABLES
- BRAKES
- TANKS & OIL FILTERS
- DASHES & GAUGES
- FRAMES & SUSPENSION
- FENDERS & LICENSE PLATE FRAMES
- FOOTRESTS
- WHEELS & AXLES
- HARDWARE, COVERS & GENERAL



1010-1998

DS-289129



1010-1997



1014-0237

1014-0040



1010-1966

1010-1735



1011-1721



1012-0235

**AIR CLEANERS**

- Original S&S teardrop air cleaner assemblies
- Include an S&S cover, backing plate and high-quality filter element and hardware kit
- Increase horsepower with no other changes
- Available for most OEM carburetors and S&S performance intake systems
- Made in the U.S.A.

NOTE: Installation of an S&S air cleaner may require re-jetting or engine re-tuning, however tuning within the OEM emissions standards is required to maintain E.O. validity.

NOTE: Some applications exempt per CARB EXECUTIVE ORDER (E. O.) No. D-355-17. E.O. applies 01-16 EFI models only.

PART #	DESCRIPTION	SUG. RETAIL
<b>CHROME AIR CLEANERS</b>		
1010-1998	For 08-16 FLHT/FLHR/FLHX/FLTR, 16-17 Softails, 16-17 FXDLs, 14-15 FLSTNSE, 13-15 FXSBSE, 11-12 FLTSTSE, CARB EO# D-355-17	\$239.95
1010-1996	For 01-17 Big Twin models w/ Delphi EFI (except 08-17 Touring, 16-17 FXDLs, 16-17 Softail, 14-15 FLSTNSE, 13-15 FXSBSE, 11-12 FLTSTSE), CARB EO# D-355-17	239.95
DS-289137	For 99-06 Twin Cam models w/ E & G series carbs	239.95
1010-0325	For 93-06 Big Twin w/ stock CV carb	239.95
DS289211	For 92-99 Evolution Big Twin models w/ E & G series carbs	239.95
DS-289129	For 84-92 Big Twin and 86-90 XL models w/ E & G series carbs	239.95
1010-2000	For 07-17 XL stock EFI, CARB EO# D-355-17	239.95
1010-0326	For 91-06 XL w/ stock CV carb	239.95

PART #	DESCRIPTION	SUG. RETAIL
<b>GLOSS BLACK AIR CLEANERS</b>		
1010-1999	For 08-16 FLHT/FLHR/FLHX/FLTR, 16-17 Softails, 16-17 FXDLs, 14-15 FLSTNSE, 13-15 FXSBSE, 11-12 FLTSTSE, CARB EO# D-355-17	\$239.95
1010-1997	For 01-17 Big Twin models w/ Delphi EFI (except 08-17 Touring, 16-17 FXDLs, 16-17 Softail, 14-15 FLSTNSE, 13-15 FXSBSE, 11-12 FLTSTSE), CARB EO# D-355-17	239.95
1010-1866	For 93-06 Big Twin w/ stock CV carb	259.95
1010-2001	For 07-17 XL stock EFI, CARB EO# D-355-17	239.95

PART #	DESCRIPTION	SUG. RETAIL
<b>REPLACEMENT COMPONENTS</b>		
DS289404	Repl. S&S air cleaner cover for E & G carb, chrome	\$143.95
1014-0133	Repl. S&S air cleaner cover for E & G carb, black	121.95
DS289403	Repl. S&S air cleaner cover for S&S CV air cleaner and Super B carbs, chrome	149.95
1014-0237	Repl. S&S air cleaner cover for E & G carb, gloss black	143.95
1014-0040	Repl. Slasher-style air cover; repl. for all E & G carbs, chrome	143.95
DS289405	Repl. air cleaner cover screws (10-pk.)	.95 (ea.)
1012-0222	Repl. vent screw fitting (ea.)	10.95
1010-1966	Repl. tear-drop backplate (ea.)	93.95
0934-4760	Repl. backplate tear-drop gasket (10-pk.)	1.45 (ea.)
1010-1735	Repl. gasket, backplate, Super E/G, CV Adapter, .0625"	1.45
1011-0324	Repl. crankcase breather hose for 93-06 Big Twin, 91-06 XL and 94-02 Buells	5.95
1011-0325	Breather screw seals (silicone-coated steel washer), .520" i.d. (10-pk.)	1.25 (ea.)

PART #	DESCRIPTION	SUG. RETAIL
<b>REPLACEMENT COMPONENTS (CONT)</b>		
1011-0326	Breather screw seals (silicone-coated steel washer), .380" i.d. (10-pk.)	\$1.25 (ea.)
1011-1721	Repl. filter element for DS-289137, DS-289211, DS-289128, DS-289129, DS-289130, 1010-0325, 1010-0326, 1010-0235, 1010-0236, 1010-0237, 1010-0419	20.95
DS289409	Repl. filter element for DS-289070, DS-289400, DS-289401, DS-289402, DS-289410 and S&S Super B	16.95
1010-1992	Backplate screw w/ thread lock 1/4-20 x 1/2", zinc plated, alloy steel	1.00
1012-0235	Hardware kit, Super E/G, 99-06 Twin Cam	66.95
1011-3844	Washer, rubber coated steel, 7/8 x .380" x .021" (ea.)	1.10
1011-3845	Washer, rubber coated steel, 7/8 x .520" x .024" (ea.)	1.10
1012-0231	Breather screw for Twin Cam, 5/16-24 x .360" (ea.)	3.95
1012-0232	Breather screw, 1/2-13 92-99 Big Twin (ea.)	9.95
1012-0233	Vent fitting, aluminum alloy (ea.)	3.45
1012-0234	Vent fitting, aluminum alloy (pr.)	6.25

**HIGH-FLOW AIR FILTER AND ADAPTER KIT**

- High-flow filter designed especially for Super E and G carburetors
- Filter is 1" taller than standard filter and features a low-restriction, pre-oiled filter element
- Allows for a 37% increase in airflow
- Filter and adapters extend the teardrop housing out 1" for better exposure and a high-performance street racer look
- Kit installs in minutes; no permanent modifications required
- Made in the U.S.A.

DISCLAIMER: FOR CLOSED COURSE COMPETITION USE ONLY. NOT INTENDED FOR STREET USE.

NOTE: Not for use with S&S Super B or Super D carburetors, or Super E and G Kits for Buells.

PART #	DESCRIPTION	SUG. RETAIL
1011-0323	For S&S Super E and G carbs	\$52.95
1011-2286	Repl. high-flow filter for S&S Super E and G carbs (also fits S&S air cleaners for stock carbs and EFI throttle bodies)	22.95

DISCLAIMER: NOT LEGAL FOR SALE OR USE IN CALIFORNIA ON ANY POLLUTION CONTROLLED MOTOR VEHICLES. SEE PAGE 399 FOR IMPORTANT EMISSION DEFINITIONS AND REGULATORY COMPLIANCE AND WARRANTY INFORMATION.

All part numbers in BLUE are new for 2017.

1011-0323





1010-1078



1010-1077



1010-1313



1014-0225

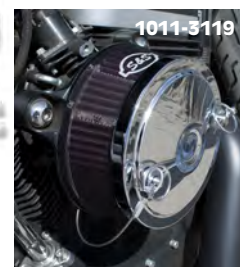

1011-3119

**SUPER STOCK™ STEALTH AIR CLEANER KITS**

- For stock and S&S fuel system applications
- Kits include backing plate, filter and hardware
- Built-in stinger cone directs air smoothly into the bore of the carburetor or EFI throttle body and reduces turbulence and increases flow
- Optional high-flow (1" taller) filter and pre-filter/rain sock also available
- Made in the U.S.A.

NOTE: Kits do not come with covers. Must use with stock Twin Cam 88®, 96™, or 103™ "football-style" air cleaner cover, or can be used with S&S Stealth air cleaner covers (sold separately). Use PART #1014-0225 adapter to install stock cover on 14-16 Touring bikes.

NOTE: Some applications exempt per CARB EXECUTIVE ORDER (E.O.) No. D-355-17. E.O. applies to 01-16 EFI models only.

NOTE: Stealth air cleaner kits for 01-16 EFI applications come with a special sticker and instructions for applying it to an inconspicuous location on the frame.

PART #	DESCRIPTION	SUG. RETAIL
<b>SUPER STOCK™ STEALTH AIR CLEANER KITS</b>		
1010-1994	For 08-16 FLHT/FLHX/FLTR, H-D Trike, 16-17 FXDLS, 16-17 Softails, 11-12 FLSTSE, 13-15 FXSBSE and 14-15 FLSTNSE models, CARB EO# D-355-17	\$129.95
1010-1993	For 01-17 Twin Cam w/ Delphi EFI (except 08-17 Dresser/H-D Trike, 16-17 FXDLS, 16-17 Softails, 11-12 FLSTSE, 13-15 FXSBSE and 14-15 FLSTNSE), CARB EO# D-355-17	129.95
1010-1508	For 99-06 Twin Cam Big Twin w/ stock CV carb	129.95
1010-1075	For 93-99 Evo Big Twin w/ stock CV carb	129.95
1010-1078	For 99-06 Twin Cam Big Twin w/ E/G series carb	129.95
1010-1077	For 93-99 Evo Big Twin w/ E/G series carb	129.95

PART #	DESCRIPTION	SUG. RETAIL
<b>SUPER STOCK™ STEALTH AIR CLEANER KITS (CONT)</b>		
1010-1313	For 84-92 Big Twin and 86-90 XL models w/ S&S E/G series carbs	\$149.95
1010-1995	For 07-17 XL w/ Delphi EFI, CARB EO# D-355-17	134.95
1010-1510	For 91-06 XL w/ stock CV carb	134.95
<b>REPLACEMENT/OPTIONAL COMPONENTS</b>		
1014-0225	AC air cleaner cover adapter kit for 14-16 touring models	40.95
1011-2765	Repl. Stealth filter	39.95
1011-2766	Opt. Stealth hi-flo filter kit (1" taller)	59.95
1011-3119	Pre-filter/rain sock for Standard Stealth air filter	24.95
1011-3120	Pre-filter/rain sock for 1" tall Stealth air filter	24.95

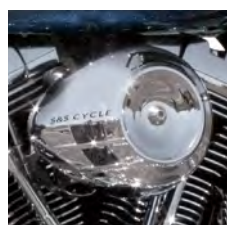

1014-0116



1014-0119



1014-0120



1014-0122

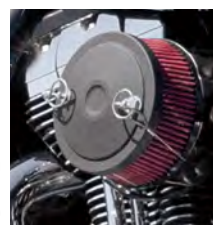

1014-0123



1014-0177



1014-0171



1014-0172



1014-0173



1014-0244



1014-0245



1014-0246

**STEALTH AIR CLEANER COVERS**

- Fit the S&S Stealth air cleaner kits
- Bob and Muscle-style air cleaner covers are machined from billet aluminum, fit over the end of the air filter and leave the filter element exposed
- Powder-coated gloss black and highlight machined
- Air Stream-style is die-cast and features screened vents for more air without sucking in rain/road hazards
- Muscle-style features muscle car-style hood pins
- Made in the U.S.A.

PART #	DESCRIPTION	SUG. RETAIL
<b>STEALTH AIR CLEANER COVERS</b>		
1014-0116	Air Stream, chrome	\$139.95
1014-0117	Air Stream, black wrinkle powder-coat	139.95
1014-0118	Bob dish, chrome	94.95
1014-0119	Bob dish, black wrinkle powder-coat	94.95
1014-0120	Bob dome, chrome	94.95
1014-0121	Bob dome, black wrinkle powder-coat	94.95
1014-0122	Muscle, chrome	134.95
1014-0123	Muscle, black wrinkle powder-coat	129.95

PART #	DESCRIPTION	SUG. RETAIL
<b>STEALTH AIR CLEANER COVERS (CONT)</b>		
1014-0177	Muscle, black wrinkle powder-coat w/ S&S logo	\$134.95
1014-0171	Tri-spoke	139.95
1014-0172	Torker	139.95
1014-0173	Air 1	139.95
1014-0244	111" Displacement	159.95
1014-0245	124" Displacement	159.95
1014-0246	143" Displacement	159.95

**DISCLAIMER:** NOT LEGAL FOR SALE OR USE IN CALIFORNIA ON ANY POLLUTION CONTROLLED MOTOR VEHICLES. SEE PAGE 399 FOR IMPORTANT EMISSION DEFINITIONS AND REGULATORY COMPLIANCE AND WARRANTY INFORMATION.

All part numbers in BLUE are new for 2017.

WINDSHIELDS & FAIRINGS

AUDIO & VIDEO

SADDLEBAGS & LUGGAGE

SEATS & SISSY BARS

EXHAUST

FUEL/AIR SYSTEMS

ENGINE

TRANSMISSION & DRIVELINE

GASKETS & SEALS

ELECTRICAL

LIGHTING

HANDLEBARS, CONTROLS & MIRRORS

CABLES

BRAKES

TANKS & OIL FILTERS

DASHES & GAUGES

FRAMES & SUSPENSION

FENDERS & LICENSE PLATE FRAMES

FOOTRESTS

WHEELS & AXLES

HARDWARE, COVERS & GENERAL

WINDSHIELDS & FAIRINGS

AUDIO & VIDEO

SADDLEBAGS & LUGGAGE

SEATS & SISSY BARS

EXHAUST

FUEL/AIR SYSTEMS

ENGINE

TRANSMISSION & DRIVELINE

GASKETS & SEALS

ELECTRICAL

LIGHTING

HANDLEBARS, CONTROLS & MIRRORS

CABLES

BRAKES

TANKS & OIL FILTERS

DASHES & GAUGES

FRAMES & SUSPENSION

FENDERS & LICENSE PLATE FRAMES

FOOTRESTS

WHEELS & AXLES

HARDWARE, COVERS & GENERAL



**INVERTED SERIES AIR CLEANER KITS**

- CNC machined from forged billet aluminum
- Forged billet air filter covers feature exposed design and a CNC inverted top that acts as a velocity stack to help pull in more air flow
- Forged billet aluminum backing plate features patented Big Sucker™ hidden breather technology and a radius air inlet for smooth airflow
- Hidden breathers are o-ringed at the heads and exits at throttle body/carb to create a virtually closed-loop system
- No external hoses or hardware needed
- Black stainless steel jacketed inverted filters feature an inverted pleated top and 360° of pleated sides to pull in filtered air from every angle
- Performance filters features a black synthetic filter element wrapped in a stainless steel jacket
- Filter is water resistant eliminating the need for a rain sock
- Available in chrome or black anodized finishes
- Made in the U.S.A.



Complete Kit

NOTE: Exempt per C.A.R.B. ref. E.O. # D-639-4, Exhibit A. (unless noted).

PART #	DESCRIPTION	SUG. RETAIL
<b>FOR 17 FLHT/FLHR/FLHX/FLTR/H-D TRIKE</b>		
1010-2085 <sup>1</sup>	Slot Track, chrome	\$419.95
1010-2086 <sup>1</sup>	Slot Track, black anodized	419.95
1010-2087 <sup>1</sup>	Deep Cut, chrome	419.95
1010-2088 <sup>1</sup>	Deep Cut, black anodized	419.95
1010-2089 <sup>1</sup>	Bevelled, chrome	419.95
1010-2090 <sup>1</sup>	Bevelled, black anodized	419.95
<b>FOR 08-16 FLHT/FLHR/FLHX/FLTR/H-D TRIKE, 16-17 FXDLS, 16-17 SOFTTAILS, 14-15 FLSTNSE, 13-14 FXSBSE and 11-12 FLTSE MODELS</b>		
1010-1202 <sup>1</sup>	Slot Track, chrome	419.95
1010-1203 <sup>1</sup>	Slot Track, black anodized	419.95
1010-1208 <sup>1</sup>	Deep Cut, chrome	419.95
1010-1209 <sup>1</sup>	Deep Cut, black anodized	419.95
1010-1214 <sup>1</sup>	Bevelled, chrome	419.95
1010-1215 <sup>1</sup>	Bevelled, black anodized	419.95
1010-1502 <sup>1</sup>	10-Gauge, chrome	419.95
1010-1503 <sup>1</sup>	10-Gauge, black anodized	419.95
<b>FOR 01-17 TWIN CAM DELPHI EFI MODELS, 99-06 TWIN CAM CV CARB MODELS (EXCEPT 08-17 FLHT/FLHR/FLHX/FLTR/H-D TRIKE, 16-17 FXDLS, 16-17 SOFTTAILS, 14-15 FLSTNSE, 13-14 FXSBSE and 11-12 FLTSE MODELS)</b>		
1010-1204 <sup>1</sup>	Slot Track, chrome	419.95
1010-1205 <sup>1</sup>	Slot Track, black anodized	419.95
1010-1210 <sup>1</sup>	Deep Cut, chrome	419.95

PART #	DESCRIPTION	SUG. RETAIL
<b>FOR 01-17 TWIN CAM DELPHI EFI MODELS, 99-06 TWIN CAM CV CARB MODELS (EXCEPT 08-17 FLHT/FLHR/FLHX/FLTR/H-D TRIKE, 16-17 FXDLS, 16-17 SOFTTAILS, 14-15 FLSTNSE, 13-14 FXSBSE and 11-12 FLTSE MODELS) (CONT)</b>		
1010-1211 <sup>1</sup>	Deep Cut, black anodized	\$419.95
1010-1216 <sup>1</sup>	Bevelled, chrome	419.95
1010-1217 <sup>1</sup>	Bevelled, black anodized	419.95
1010-1504 <sup>1</sup>	10-Gauge, chrome	419.95
1010-1505 <sup>1</sup>	10-Gauge, black anodized	419.95
<b>FOR 91-17 XL</b>		
1010-1206 <sup>1,2</sup>	Slot Track, chrome	419.95
1010-1207 <sup>1,2</sup>	Slot Track, black anodized	419.95
1010-1212 <sup>1,2</sup>	Deep Cut, chrome	419.95
1010-1213 <sup>1,2</sup>	Deep Cut, black anodized	419.95
1010-1218 <sup>1,2</sup>	Bevelled, chrome	419.95
1010-1219 <sup>1,2</sup>	Bevelled, black anodized	419.95
1010-1506 <sup>1,2</sup>	10-Gauge, chrome	419.95
1010-1507 <sup>1,2</sup>	10-Gauge, black anodized	419.95
<b>REPLACEMENT AIR FILTER</b>		
1011-2942	Repl. air filter	69.95

<sup>1</sup> 2017 models NOT YET Exempt per C.A.R.B. ref. E.O. # D-639-4, Exhibit A.  
<sup>2</sup> Will fit 88-90 models also, breather system is not applicable for these model years.

**DISCLAIMER:** NOT LEGAL FOR SALE OR USE IN CALIFORNIA ON ANY POLLUTION CONTROLLED MOTOR VEHICLES. SEE PAGE 399 FOR IMPORTANT EMISSION DEFINITIONS AND REGULATORY COMPLIANCE AND WARRANTY INFORMATION.

All part numbers in BLUE are new for 2017.

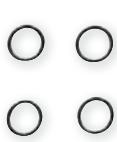

1010-0358



**"BILLET SUCKER" AIR CLEANER ASSEMBLIES**

- Available in Stage I and Stage II
- Stage 1 kits give the option to use either your OEM air cleaner cover or to install an Arlen Ness custom cover
- Stage 2 kits feature a 20% larger filter element over Stage 1 for even more airflow and require the use of a custom outer cover
- Both feature an oversized exposed filter design for tremendous airflow
- One-piece aluminum backing plate with patented hidden breather technology and radius air inlet for maximum airflow
- Breather passages exit at the mouth of the carb/throttle body, creating a virtually closed-loop system
- Eliminates the need for any external banjo fittings, hoses, and breather filters for an ultra clean look
- Kits include a high-flow air filter, chrome outer cover, chrome backing plate/support bracket and all necessary hardware
- Made in the U.S.A.

PART #	DESCRIPTION	SUG. RETAIL
<b>STAGE I KITS</b>		
1010-0355	Smooth, for 08-16 FLHT/FLHR/FLHX/FLTR/H-D FL Trike, 16-17 Softails, 17 FXDLS, 14-15 FLSTNSE, 13-14 FXSBSE and 11-12 FLSTSE models	\$219.95
1010-0357	Scalloped, for 08-16 FLHT/FLHR/FLHX/FLTR/H-D FL Trike, 16-17 Softails, 17 FXDLS, 14-15 FLSTNSE, 13-14 FXSBSE and 11-12 FLSTSE models	229.95
1010-0186	Smooth, for all 01-17 Twin Cam Delphi EFI and 99-06 Twin Cam CV carb models (except 08-16 FLHT/FLHR/FLHX/FLTR/H-D FL Trike, 16-17 Softails, 17 FXDLS, 14-15 FLSTNSE, 13-14 FXSBSE and 11-12 FLSTSE)	219.95
1010-0187	Scalloped, for all 01-17 Twin Cam Delphi EFI and 99-06 Twin Cam CV carb models (except 08-16 FLHT/FLHR/FLHX/FLTR/H-D FL Trike, 16-17 Softails, 17 FXDLS, 14-15 FLSTNSE, 13-14 FXSBSE and 11-12 FLSTSE)	229.95
<b>STAGE II KITS</b>		
1010-0356	Smooth, for 08-16 FLHT/FLHR/FLHX/FLTR/H-D FL Trike, 16-17 Softails, 17 FXDLS, 14-15 FLSTNSE, 13-14 FXSBSE and 11-12 FLSTSE models	224.95
1010-0358	Scalloped, for 08-16 FLHT/FLHR/FLHX/FLTR/H-D FL Trike, 16-17 Softails, 17 FXDLS, 14-15 FLSTNSE, 13-14 FXSBSE and 11-12 FLSTSE models	224.95
1010-0065	Scalloped, for 99-01 Twin Cam FLT fuel-injected models	249.95
1010-0066	Scalloped, for all 93-99 Evolution Big Twin models w/ CV carb	219.95
1010-0064 <sup>1</sup>	Scalloped, for 91-17 XL models	229.95

<sup>1</sup> Will fit 88-90 models, breather system is not applicable for these model years.

**DISCLAIMER:** NOT LEGAL FOR SALE OR USE IN CALIFORNIA ON ANY POLLUTION CONTROLLED MOTOR VEHICLES. SEE PAGE 399 FOR IMPORTANT EMISSION DEFINITIONS AND REGULATORY COMPLIANCE AND WARRANTY INFORMATION.

All part numbers in BLUE are new for 2017.

WINDSHIELDS & FAIRINGS

AUDIO & VIDEO

SADDLEBAGS & LUGGAGE

SEATS & SISSY BARS

EXHAUST

FUEL/AIR SYSTEMS

ENGINE

TRANSMISSION & DRIVELINE

GASKETS & SEALS

ELECTRICAL

LIGHTING

HANDLEBARS, CONTROLS & MIRRORS

CABLES

BRAKES

TANKS & OIL FILTERS

DASHES & GAUGES

FRAMES & SUSPENSION

FENDERS & LICENSE PLATE FRAMES

FOOTRESTS

WHEELS & AXLES

HARDWARE, COVERS & GENERAL



**BIG SUCKER™ AIR FILTER KITS**

- One-piece aluminum backing plate features patented hidden breather technology
- Each hidden breather is o-ringed at the heads and exits at the mouth of the injector/crab to provide efficient engine breathing, eliminating the need for any external hoses or hardware
- Radius air inlet provides maximum performance by providing unobstructed airflow
- Backing plates are available in Standard, black powder coat, or chrome finish
- Filters are available in standard red or synthetic black filter elements
- Standard red filters are pre-oiled, washable and feature four-layers of surgical grade cotton for optimum filtration and maximum airflow
- Synthetic filters feature a black synthetic material that is water resistant and never needs to be oiled; just wash and re-use
- Stage I kit accepts OEM outer cover (unless noted) or custom Ness outer cover
- Stage II kit features a 20% larger filter element and accepts an 8" round Ness outer cover only
- All necessary hardware and instructions are included with each kit

NOTE: Exempt per C.A.R.B. ref. E.O. # D-639-4, Exhibit A. (unless noted).

1010-2082 with Standard filter

1010-1760 with Synthetic filter



1010-0179 with Standard filter

PART #	DESCRIPTION	SUG. RETAIL
<b>STAGE I KITS W/ STANDARD FILTER (ACCEPTS OEM COVERS)</b>		
1010-2082 <sup>1</sup>	For 17 FLHT/FLHR/FLHX/FLTRX/H-D FL Trike (natural)	\$159.95
1010-2083 <sup>1</sup>	For 17 FLHT/FLHR/FLHX/FLTRX/H-D FL Trike (chrome)	179.95
1010-2084 <sup>1</sup>	For 17 FLHT/FLHR/FLHX/FLTRX/H-D FL Trike (black)	169.95
1010-1461 <sup>1</sup>	For 14-16 FLHT/FLHR/FLHX/FLTR/H-D FL Trike and 16-17 Softails (except FLSS/FLSTFBS) models (natural)	139.95
1010-1462 <sup>1</sup>	For 14-16 FLHT/FLHR/FLHX/FLTR/H-D FL Trike and 16-17 Softails (except FLSS/FLSTFBS) models (chrome)	159.95
1010-1463 <sup>1</sup>	For 14-16 FLHT/FLHR/FLHX/FLTR/H-D FL Trike and 16-17 Softails (except FLSS/FLSTFBS) models (black)	159.95
1010-0351	For 08-13 FLHT/FLHR/FLHX/FLTR and H-D FL Trike models (natural)	129.95
1010-0353	For 08-13 FLHT/FLHR/FLHX/FLTR and H-D FL Trike models (chrome)	149.95
DS-288882	For 99-01 FLHTI/FLHRI (natural)	129.95
1010-1013 <sup>1</sup>	For 08-17 FXD/FXDWG (except 16-17 FXDLS, 16-17 models with high-output air cleaners) (natural)	139.95
1010-1012 <sup>1</sup>	For 08-17 FXD/FXDWG (except 16-17 FXDLS, 16-17 models with high-output air cleaners) (chrome)	159.95
1010-1011 <sup>1</sup>	For 08-17 FXD/FXDWG (except 16-17 FXDLS, 16-17 models with high-output air cleaners) (black)	159.95
1010-0179 <sup>1</sup>	For 01-17 Twin Cam Delphi EFI models and 99-06 Twin Cam CV carb models (except 16-17 Softails, 16-17 FXDLS, 08-17 FXD/FXDWG, 08-17 FLHT/FLHR/FLHX/FLTR and H-D FL Trike models) (natural)	129.95
1010-0181 <sup>1</sup>	For 01-17 Twin Cam Delphi EFI models and 99-06 Twin Cam CV carb models (except 16-17 Softails, 16-17 FXDLS, 08-17 FXD/FXDWG, 08-17 FLHT/FLHR/FLHX/FLTR and H-D FL Trike models) (chrome)	149.95
DS-288880	For 93-99 Evolution Big Twin models w/ CV carb (natural)	129.95
1010-1014 <sup>1, 2, 3</sup>	For 91-17 XL models (except 883N/1200X/1200V) (natural)	139.95
1010-0891 <sup>1, 2, 3</sup>	For 91-17 XL models (except 883N/1200X/1200V) (chrome)	159.95
1010-0892 <sup>1, 2, 3</sup>	For 91-17 XL models (except 883N/1200X/1200V) (black)	159.95
1010-2062 <sup>1, 2</sup>	For 09-17 883N/1200X/1200V XL models (natural)	139.95
1010-2063 <sup>1, 2</sup>	For 09-17 883N/1200X/1200V XL models (chrome)	159.95
1010-2064 <sup>1, 2</sup>	For 09-17 883N/1200X/1200V XL models (black)	159.95
<b>STAGE I KITS W/ SYNTHETIC FILTER (ACCEPTS OEM COVERS)</b>		
1010-1759 <sup>1</sup>	For 01-17 Twin Cam Delphi EFI models and 99-06 Twin Cam CV carb models (except 16-17 Softails, 16-17 FXDLS, 08-17 FXD/FXDWG, 08-17 FLHT/FLHR/FLHX/FLTR and H-D FL Trike models) (chrome)	169.95
1010-1760 <sup>1</sup>	For 01-17 Twin Cam Delphi EFI models and 99-06 Twin Cam CV carb models (except 16-17 Softails, 16-17 FXDLS, 08-17 FXD/FXDWG, 08-17 FLHT/FLHR/FLHX/FLTR and H-D FL Trike models) (black)	169.95
1010-1757 <sup>1</sup>	For 14-16 FLHT/FLHR/FLHX/FLTR/H-D FL Trike and 16-17 Softails (except FLSS, FLSTFBS) models (chrome)	169.95
1010-1758 <sup>1</sup>	For 14-16 FLHT/FLHR/FLHX/FLTR/H-D FL Trike and 16-17 Softails (except FLSS, FLSTFBS) models (black)	169.95
1010-1761 <sup>1</sup>	For 93-99 Evolution Big Twin models w/ CV carb (chrome)	169.95
1010-1762 <sup>1</sup>	For 93-99 Evolution Big Twin models w/ CV carb (black)	169.95
1010-1765 <sup>1</sup>	For 91-17 XL models (chrome)	169.95
1010-1766 <sup>1</sup>	For 91-17 XL models (black)	169.95
1010-1810 <sup>4</sup>	For 15-17 XG500/750 (chrome)	139.95
1010-1811 <sup>1</sup>	For 15-17 XG500/750 (black)	159.95
<b>STAGE I KITS W/ STANDARD FILTER (ACCEPTS 8" ROUND AFTERMARKET COVERS ONLY)</b>		
1010-0179 <sup>1</sup>	For 08-17 FXD/FXDWG (natural)	129.95
1010-0181 <sup>1</sup>	For 08-17 FXD/FXDWG (chrome)	149.95
1010-0060 <sup>1, 3</sup>	For 91-17 XL models (natural)	129.95
<b>STAGE II KITS W/ STANDARD FILTER (ACCEPTS 8" ROUND AFTERMARKET OUTER COVERS ONLY)</b>		
1010-0352 <sup>1</sup>	For 08-16 FLHT/FLHR/FLHX/FLTR and H-D FL Trike, 16-17 FXDLS, 16-17 Softails, 14-15 FLSTNSE, 13-14 FXSBSE and 11-12 FLSTSE models (natural)	139.95
1010-0354 <sup>1</sup>	For 08-16 FLHT/FLHR/FLHX/FLTR and H-D FL Trike, 16-17 FXDLS, 16-17 Softails, 14-15 FLSTNSE, 13-14 FXSBSE and 11-12 FLSTSE models (chrome)	159.95
DS-288883	For 99-01 FLHTI/FLHRI (natural)	139.95
1010-0180 <sup>1</sup>	For 01-17 Twin Cam Delphi EFI models and 99-06 Twin Cam CV carb models (except 08-17 FLHT/FLHR/FLHX/FLTR/H-D FL Trike, 16-17 FXDLS, 16-17 Softails, 14-15 FLSTNSE, 13-14 FXSBSE and 11-12 FLSTSE models) (natural)	139.95
1010-0185 <sup>1</sup>	For 01-17 Twin Cam Delphi EFI models and 99-06 Twin Cam CV carb models (except 08-17 FLHT/FLHR/FLHX/FLTR/H-D FL Trike, 16-17 FXDLS, 16-17 Softails, 14-15 FLSTNSE, 13-14 FXSBSE and 11-12 FLSTSE models) (chrome)	159.95
DS-288881	For 93-99 Evolution Big Twin models w/ CV carb (natural)	139.95
1010-0061 <sup>1, 3</sup>	For 91-17 XL models (natural)	139.95

<sup>1</sup> 2017 models NOT YET Exempt per C.A.R.B. ref. E.O. # D-639-4, Exhibit A.

<sup>2</sup> Accepts factory air cleaner cover only.

<sup>3</sup> Will fit 88-90 models also; breather system is not applicable for these model years.

<sup>4</sup> NOT Exempt per C.A.R.B. ref. E.O. # D-639-4, Exhibit A.

**DISCLAIMER:** NOT LEGAL FOR SALE OR USE IN CALIFORNIA ON ANY POLLUTION CONTROLLED MOTOR VEHICLES. SEE PAGE 399 FOR IMPORTANT EMISSION DEFINITIONS AND REGULATORY COMPLIANCE AND WARRANTY INFORMATION.

All part numbers in BLUE are new for 2017.

WINDSHIELDS & FAIRINGS

AUDIO & VIDEO

SADDLEBAGS & LUGGAGE

SEATS & Sissy BARS

EXHAUST

FUEL/AIR SYSTEMS

ENGINE

TRANSMISSION & DRIVELINE

GASKETS & SEALS

ELECTRICAL

LIGHTING

HANDLEBARS, CONTROLS & MIRRORS

CABLES

BRAKES

TANKS & OIL FILTERS

DASHES & GAUGES

FRAMES & SUSPENSION

FENDERS & LICENSE PLATE FRAMES

FOOTRESTS

WHEELS & AXLES

HARDWARE, COVERS & GENERAL



1010-0869



1010-0875

1010-2065

1010-2070



1010-2076



1010-1607

**BIG SUCKER™ STAGE I AIR FILTER KITS WITH COVER**

- One-piece aluminum backing plate features patented hidden breather technology
- Each hidden breather is o-ringed at the heads and exits at the mouth of the injector/crab to provide efficient engine breathing, eliminating the need for any external hoses or hardware
- Radius air inlet provides maximum performance by providing unobstructed airflow
- Backing plates are available in Standard, black powder coat, or chrome finish
- Kits are available with standard red or synthetic black filter elements
- Standard red filters are pre-oiled, washable and feature four-layers of surgical grade cotton for optimum filtration and maximum airflow
- Synthetic filters feature a black synthetic material that is water resistant and never needs to be oiled; just wash and re-use
- All kits include high-performance filter, backing plate and steel outer cover
- All necessary hardware and instructions are included with each kit

NOTE: Kits with Synthetic filter are exempt per C.A.R.B. ref. E.O. # D-639-4, Exhibit A.

PART #	DESCRIPTION	SUG. RETAIL
<b>KITS W/ STANDARD FILTER</b>		
<b>FOR 08-13 FLHT/FLHR/FLHX/FLTR AND H-D FL TRIKE MODELS</b>		
1010-0869	Smooth, chrome	\$159.95
1010-0874	Smooth, black	159.95
<b>FOR 99-01 FLHTI/FLHRI</b>		
1010-0872	Smooth, chrome	159.95
1010-0877	Smooth, black	159.95
<b>FOR 01-17 TWIN CAM DELPHI EFI AND 99-06 TWIN CAM CV CARB MODELS (EXCEPT 08-17 FLHT/FLHR/FLHX/FLTR, H-D FL TRIKE AND 16-17 SOFTAIL, 16-17 FXDLS MODELS)</b>		
1010-0870	Smooth, chrome	159.95
1010-0875	Smooth, black	159.95
<b>FOR 93-99 EVOLUTION BIG TWIN MODELS W/ CV CARB</b>		
1010-0871	Smooth, chrome	159.95
1010-0876	Smooth, black	159.95
<b>FOR 91-17 XL MODELS W/ CV CARB OR DELPHI EFI</b>		
1010-0873 <sup>1</sup>	Smooth, chrome	159.95
1010-0878 <sup>1</sup>	Smooth, black	159.95
<b>KITS W/ SYNTHETIC FILTER</b>		
<b>FOR 08-13 FLHT/FLHR/FLHX/FLTR AND H-D FL TRIKE MODELS</b>		
1010-1600	Smooth, chrome	179.95
1010-1604	Smooth, black	179.95
1010-2065	Slot Track, black	234.95
1010-2070	Beveled, black	234.95
1010-2075	Beveled, chrome	234.95

PART #	DESCRIPTION	SUG. RETAIL
<b>KITS W/ SYNTHETIC FILTER (CONT)</b>		
<b>FOR 99-01 FLHTI/FLHRI</b>		
1010-2068	Slot Track, black	\$234.95
1010-2073	Beveled, black	234.95
1010-2078	Beveled, chrome	234.95
<b>FOR ALL 01-17 TWIN CAM DELPHI EFI AND 99-06 TWIN CAM CV CARB MODELS (EXCEPT 08-17 FLHT/FLHR/FLHX/FLTR, H-D FL TRIKE AND 16-17 SOFTAIL, 16-17 FXDLS MODELS)</b>		
1010-1601	Smooth, chrome	179.95
1010-1605	Smooth, black	179.95
1010-2066	Slot Track, black	234.95
1010-2071	Beveled, black	234.95
1010-2076	Beveled, chrome	234.95
<b>FOR ALL 93-99 EVOLUTION BIG TWIN MODELS W/ CV CARB</b>		
1010-1602	Smooth, chrome	179.95
1010-1606	Smooth, black	179.95
1010-2067	Slot Track, black	234.95
1010-2072	Beveled, black	234.95
1010-2077	Beveled, chrome	234.95
<b>FOR 91-17 XL MODELS W/ CV CARB OR DELPHI EFI</b>		
1010-1603	Smooth, chrome	179.95
1010-1607	Smooth, black	179.95
1010-2069	Slot Track, black	234.95
1010-2074	Beveled, black	234.95
1010-2079	Beveled, chrome	234.95

<sup>1</sup> Will fit 88-90 models also, breather system is not applicable for these model years.

**DISCLAIMER:** NOT LEGAL FOR SALE OR USE IN CALIFORNIA ON ANY POLLUTION CONTROLLED MOTOR VEHICLES. SEE PAGE 399 FOR IMPORTANT EMISSION DEFINITIONS AND REGULATORY COMPLIANCE AND WARRANTY INFORMATION.

All part numbers in BLUE are new for 2017.



WINDSHIELDS & FAIRINGS

AUDIO & VIDEO

SADDLEBAGS & LUGGAGE

SEATS & SISSY BARS

EXHAUST

FUEL/AIR SYSTEMS

ENGINE

TRANSMISSION & DRIVELINE

GASKETS & SEALS

ELECTRICAL

LIGHTING

HANDLEBARS, CONTROLS & MIRRORS

CABLES

BRAKES

TANKS & OIL FILTERS

DASHES & GAUGES

FRAMES & SUSPENSION

FENDERS & LICENSE PLATE FRAMES

FOOTRESTS

WHEELS & AXLES

HARDWARE, COVERS & GENERAL



Stainless steel jacketed filter

**BIG SUCKER™ STAGE II AIR FILTER KITS WITH COVER**

- Features a one-piece aluminum backing plate/carb support bracket with patented hidden breather technology and radius air inlet
- Eliminates the need for banjo fittings, hoses and filter
- Breather passages exit at the mouth of the carburetor/throttle body, creating a virtually closed-loop system
- Kit includes a 20% larger high-performance filter and steel outer cover
- Includes Standard pre-oiled filters
- All necessary hardware and instructions are included
- Made in the U.S.A.

PART #	DESCRIPTION	SUG. RETAIL
<b>1010-0432</b>	For 08-16 FLHT/FLHR/FLHX/FLTR, H-D FL Trike, 16-17 Softails, 16-17 FXDLS, 14-15 FLSTNSE, 13-14 FXSBSE and 11-12 FLSTSE models (chrome)	<b>\$169.95</b>
<b>1010-0434</b>	For 08-16 FLHT/FLHR/FLHX/FLTR, H-D FL Trike, 16-17 Softails, 16-17 FXDLS, 14-15 FLSTNSE, 13-14 FXSBSE and 11-12 FLSTSE models (wrinkle black)	<b>169.95</b>
<b>1010-0428</b>	For 99-01 FLHTI/FLHRI (chrome)	<b>169.95</b>
<b>1010-0431</b>	For 01-17 Twin Cam Delphi EFI and 99-06 Twin Cam CV carb models (except 08-17 FLHT/FLHR/FLHX/FLTR, H-D FL Trike, 16-17 Softails, 16-17 FXDLS, 14-15 FLSTNSE, 13-14 FXSBSE and 11-12 FLSTSE models) (chrome)	<b>169.95</b>
<b>1010-0433</b>	For 01-17 Twin Cam Delphi EFI and 99-06 Twin Cam CV carb models (except 08-17 FLHT/FLHR/FLHX/FLTR, H-D FL Trike, 16-17 Softails, 16-17 FXDLS, 14-15 FLSTNSE, 13-14 FXSBSE and 11-12 FLSTSE models) (wrinkle black)	<b>189.95</b>
<b>1010-0430</b>	For 93-99 Evolution Big Twin models w/ CV carb (chrome)	<b>169.95</b>
<b>1010-0429<sup>1</sup></b>	For 91-17 XL models w/ CV carb or Delphi EFI (chrome)	<b>169.95</b>

<sup>1</sup> Will fit 88-90 models also, breather system is not applicable for these model years.

**DISCLAIMER:** NOT LEGAL FOR SALE OR USE IN CALIFORNIA ON ANY POLLUTION CONTROLLED MOTOR VEHICLES. SEE PAGE 399 FOR IMPORTANT EMISSION DEFINITIONS AND REGULATORY COMPLIANCE AND WARRANTY INFORMATION.

All part numbers in **BLUE** are new for 2017.



**BIG SUCKER DERBY COVER AIR FILTER KITS**

- Unique air filter kits feature a five-hole mounting system, which allows Twin Cam derby covers (not included) to be bolted on as the outer cover
- Includes a Standard pre-oiled filter
- Includes patented Ness hidden breather Big Sucker backing plates in either chrome or powder-coated black wrinkle finish

NOTE: Exempt per C.A.R.B. ref. E.O. # D-639-4, Exhibit A.

PART #	DESCRIPTION	SUG. RETAIL
1010-0631 <sup>1</sup>	For 08-16 FLHT/FLHR/FLHX/FLTR/H-D FL Trike, 16-17 Softails, 16-17 FXDLS, 14-15 FLSTNSE, 13-14 FXSBSE and 11-12 FLTSE models (chrome)	\$169.95
1010-0633 <sup>1</sup>	For 08-16 FLHT/FLHR/FLHX/FLTR/H-D FL Trike, 16-17 Softails, 16-17 FXDLS, 14-15 FLSTNSE, 13-14 FXSBSE and 11-12 FLTSE models (black)	169.95
1010-0575	For 99-01 Twin Cam FLT fuel-injected models (chrome)	169.95
1010-0639 <sup>1</sup>	For all 01-17 Twin Cam Delphi EFI and 99-06 Twin Cam CV carb models (except 08-17 FLHT/FLHR/FLHX/FLTR/H-D FL Trike, 16-17 Softails, 17 FXDLS, 14-15 FLSTNSE, 13-14 FXSBSE and 11-12 FLTSE models) (chrome)	169.95
1010-0640 <sup>1</sup>	For all 01-17 Twin Cam Delphi EFI and 99-06 Twin Cam CV carb models (except 08-17 FLHT/FLHR/FLHX/FLTR/H-D FL Trike, 16-17 Softails, 17 FXDLS, 14-15 FLSTNSE, 13-14 FXSBSE and 11-12 FLTSE models) (black)	169.95
1010-0632	For all 93-99 Evolution Big Twin models w/ CV carb (chrome)	169.95
1010-0634	For all 93-99 Evolution Big Twin models w/ CV carb (black)	169.95
1010-0576 <sup>1,2</sup>	For 91-17 XL models w/ CV carb or Delphi EFI (chrome)	169.95
1010-0578 <sup>1,2</sup>	For 91-17 XL models w/ CV carb or Delphi EFI (black)	169.95

<sup>1</sup> 2017 models NOT YET Exempt per C.A.R.B. ref. E.O. # D-639-4, Exhibit A.

<sup>2</sup> Will fit 88-90 models also, breather system is not applicable for these model years.



**DERBY SUCKER AIR FILTER FOR SCREAMIN' EAGLE® BACKING PLATES**

- Innovative filter upgrade for stock Screamin' Eagle® air cleaner
- Accepts any 5-hole Big Twin style derby cover (sold separately)
- Comes with everything needed to mount to a round Screamin' Eagle® backing plate
- Available with Standard red filter

NOTE: Exempt per C.A.R.B. ref. E.O. # D-639-4, Exhibit A.

PART #	DESCRIPTION	SUG. RETAIL
1010-1055	For 99-15 FXST/FLST, 02-07 FLHT, 97-07 FXD	\$69.95

**DISCLAIMER:** NOT LEGAL FOR SALE OR USE IN CALIFORNIA ON ANY POLLUTION CONTROLLED MOTOR VEHICLES. SEE PAGE 399 FOR IMPORTANT EMISSION DEFINITIONS AND REGULATORY COMPLIANCE AND WARRANTY INFORMATION.

All part numbers in BLUE are new for 2017.

WINDSHIELDS & FAIRINGS

AUDIO & VIDEO

SADDLEBAGS & LUGGAGE

SEATS & SISSY BARS

EXHAUST

FUEL/AIR SYSTEMS

ENGINE

TRANSMISSION & DRIVELINE

GASKETS & SEALS

ELECTRICAL

LIGHTING

HANDLEBARS, CONTROLS & MIRRORS

CABLES

BRAKES

TANKS & OIL FILTERS

DASHES & GAUGES

FRAMES & SUSPENSION

FENDERS & LICENSE PLATE FRAMES

FOOTRESTS

WHEELS & AXLES

HARDWARE, COVERS & GENERAL



**BILLET SUCKER AND BIG SUCKER COMPONENTS**

•Replacement and optional components for all Ness Billet Sucker and Big Sucker air filter kits

PART #	DESCRIPTION	SUG. RETAIL
<b>REPLACEMENT/OPTIONAL COMPONENTS</b>		
<b>1010-0583</b>	Stage I hardware kit for 99-06 Twin Cam CV carb and all 01-17 Twin Cam Delphi EFI models	<b>\$34.95</b>
<b>1010-0584</b>	Stage I hardware kit for 93-99 Evolution Big Twin models w/ CV carb	<b>34.95</b>
<b>1010-0585</b>	Stage I hardware kit for 99-01 Twin Cam FLT fuel-injected models	<b>34.95</b>
<b>1010-0586</b>	Stage I hardware kit for 91-17 XL models	<b>34.95</b>
<b>1010-0591</b>	Stage II hardware kit for 99-06 Twin Cam CV carb and all 01-17 Twin Cam Delphi EFI models	<b>34.95</b>
<b>1010-0592</b>	Stage II hardware kit for 93-99 Evolution Big Twin models w/ CV carb	<b>34.95</b>
<b>1010-0593</b>	Stage II hardware kit for 99-01 Twin Cam FLT fuel-injected models	<b>34.95</b>
<b>1010-0594</b>	Stage II hardware kit for 91-17 XL models	<b>34.95</b>
<b>1011-3151</b>	Stage I air filter for 14-17 FLHT/FLHX/FLTR/H-D FL Trike, 16-17 FXDLS, 16-17 Softails except FLSS/FLSTFBS models	<b>59.95</b>
<b>1010-0360</b>	Stage I air filter for 08-13 FLHT/FLHR/FLHX/FLTR and H-D FL Trike models	<b>49.95</b>
<b>2110-9494</b>	Stage I air filter for 99-10 FXST, 02-07 FLHT, 97-07 FXD/FXDWG	<b>49.95</b>
<b>2110-9496</b>	Stage I air filter for DS-288882 only	<b>49.95</b>
<b>1011-2851</b>	Stage I air filter for PART #s 1010-1014, 1010-0891 and 1010-0892	<b>49.95</b>
<b>1010-0361</b>	Stage II air filter for 08-17 FLHT/FLHR/FLHX/FLTR/H-D FL Trike, 16-17 FXDLS, 16-17 Softails, 14-15 FLSTNSE, 13-14 FXSBSE and 11-12 FLSTSE models	<b>54.95</b>
<b>2110-9495</b>	Stage II air filter element (except 08-17 FLHT/FLHR/FLHX/FLTR/H-D FL Trike, 16-17 FXDLS, 16-17 Softails, 14-15 FLSTNSE, 13-14 FXSBSE and 11-12 FLSTSE models)	<b>54.95</b>
<b>1011-2769</b>	Big Sucker Derby Cover standard air filter for 08-17 FLHT/FLHR/FLHX/FLTR/H-D FL Trike, 16-17 FXDLS, 16-17 Softails, 14-15 FLSTNSE, 13-14 FXSBSE and 11-12 FLSTSE models	<b>64.95</b>
<b>1011-2771</b>	Big Sucker Derby Cover standard air filter for all 99-06 Twin Cam CV carb and 01-17 Twin Cam Delphi EFI models (except 08-17 FLHT/FLHR/FLHX/FLTR/H-D FL Trike, 16-17 FXDLS, 16-17 Softails, 14-15 FLSTNSE, 13-14 FXSBSE and 11-12 FLSTSE models)	<b>64.95</b>
<b>1011-2773</b>	Big Sucker Derby Cover standard air filter for 99-01 Twin Cam FLT fuel-injected models	<b>64.95</b>
<b>1011-2771</b>	Big Sucker Derby Cover standard air filter for 91-17 XL models	<b>64.95</b>
<b>1010-0587</b>	Gasket kit for 08-16 FLT and H-D FL Trike models	<b>7.95</b>
<b>1010-0588</b>	Gasket kit for 01-17 Twin Cam Delphi EFI, 99-06 Twin Cam CV carb (except 08-17 FLHT/FLHR/FLHX/FLTR/H-D FL Trike, 16-17 FXDLS, 16-17 Softails, 14-15 FLSTNSE, 13-14 FXSBSE and 11-12 FLSTSE models), 93-99 Evolution Big Twin models w/ CV carb, 99-05 Twin Cam Carb and Delphi EFI models	<b>7.95</b>
<b>1010-0589</b>	Gasket kit for 99-01 Twin Cam FLT fuel-injected models	<b>7.95</b>
<b>1010-0590</b>	Gasket kit for 91-17 XL models	<b>7.95</b>
<b>1014-0030<sup>1</sup></b>	Optional Stage I scalloped outer cover (chrome)	<b>119.95</b>
<b>1014-0044<sup>1</sup></b>	Optional Stage I scalloped outer cover (black/raw)	<b>119.95</b>
<b>1014-0091<sup>1</sup></b>	Optional Stage I smooth outer cover (chrome)	<b>49.95</b>
<b>1014-0092<sup>1</sup></b>	Optional Stage I smooth outer cover (black)	<b>49.95</b>
<b>1014-0226<sup>1</sup></b>	Optional Stage I slotted outer cover (black)	<b>119.95</b>
<b>1014-0227<sup>1</sup></b>	Optional Stage I slotted outer cover (chrome)	<b>119.95</b>
<b>1014-0228<sup>1</sup></b>	Optional Stage I beveled outer cover (black)	<b>119.95</b>
<b>1010-0067</b>	Optional Stage II scalloped outer cover (chrome)	<b>119.95</b>
<b>1014-0045</b>	Optional Stage II scalloped outer cover (black/raw)	<b>119.95</b>
<b>1011-3242</b>	Big Sucker Stage I pre-filter	<b>39.95</b>
<b>1011-3243</b>	Big Sucker Stage II pre-filter	<b>39.95</b>

<sup>1</sup> Not for PART #s 1010-0891, 1010-0892, 1010-1014, 1010-1011, 1010-1012 and 1010-1013.

**DOUBLE BARREL AIR FILTER ASSEMBLIES**

- Leading-edge design changes the look and performance of your bike
- Includes aluminum double-barrel outer cover, aluminum radius inlet backing plate, pre-oiled high-performance air filter and all necessary hardware
- Filter is reusable and washable
- Available in chrome or powder-coated black wrinkle finish



PART #	DESCRIPTION	SUG. RETAIL
<b>1010-0606</b>	For 08-16 FLHT/FLHR/FLHX/FLTR/H-D FL Trike, 16-17 FXDLS, 16-17 Softails, 14-15 FLSTNSE, 13-14 FXSBSE and 11-12 FLSTSE models (chrome)	<b>\$279.95</b>
<b>1010-0607</b>	For 08-16 FLHT/FLHR/FLHX/FLTR/H-D FL Trike, 16-17 FXDLS, 16-17 Softails, 14-15 FLSTNSE, 13-14 FXSBSE and 11-12 FLSTSE models (black)	<b>279.95</b>
<b>1010-0608</b>	For all 01-17 Twin Cam Delphi EFI and 99-06 Twin Cam CV carb models (except 08-17 FLHT/FLHR/FLHX/FLTR/H-D FL Trike, 16-17 FXDLS, 16-17 Softails, 14-15 FLSTNSE, 13-14 FXSBSE and 11-12 FLSTSE models) (chrome)	<b>279.95</b>
<b>1010-0609</b>	For all 01-17 Twin Cam Delphi EFI and 99-06 Twin Cam CV carb models (except 08-17 FLHT/FLHR/FLHX/FLTR/H-D FL Trike, 16-17 FXDLS, 16-17 Softails, 14-15 FLSTNSE, 13-14 FXSBSE and 11-12 FLSTSE models) (black)	<b>279.95</b>
<b>1010-0579</b>	For 91-17 XL models w/ CV carb or Delphi EFI (chrome)	<b>279.95</b>
<b>1010-0580</b>	For 91-17 XL models w/ CV carb or Delphi EFI (black)	<b>279.95</b>

**DISCLAIMER:** NOT LEGAL FOR SALE OR USE IN CALIFORNIA ON ANY POLLUTION CONTROLLED MOTOR VEHICLES. SEE PAGE 399 FOR IMPORTANT EMISSION DEFINITIONS AND REGULATORY COMPLIANCE AND WARRANTY INFORMATION.

All part numbers in **BLUE** are new for 2017.



1010-0050



1010-0053



1010-0055



1010-0058



1010-0059

**OMEGA AIR CLEANER ASSEMBLIES**

- CNC-machined from billet aluminum
- Features high-flow K&N filter #KA-6589
- Improves leg clearance over the stock air cleaner assembly due to its compact design
- Made in the U.S.A.

PART #	DESCRIPTION	SUG. RETAIL
<b>FOR 01-17 TWIN CAM W/ DELPHI EFI, 99-06 TWIN CAM W/ CV CARB (EXCEPT 08-17 FLHT/FLHR/FLHX/FLTR, HD FL TRIKE, 16-17 SOFTTAILS, 14-15 FLSTNSE, 13-14 FXSBSE, 11-12 FLTSE, 16-17 FXDLS)</b>		
1010-2030	Finned, black anodized	\$429.95
1010-2031	Finned, black anodized/silver accents	429.95
1010-2032	Finned, chrome	429.95
1010-2033	Smooth, black anodized	429.95
1010-2034	Smooth, chrome	429.95
1010-2035	Tech, black anodized	429.95
1010-2036	Tech, black anodized/silver accents	429.95
1010-2037	Tech, chrome	429.95
1010-2038	V Fin, black anodized	429.95
1010-2039	V Fin, black anodized/silver accents	429.95
1010-2040	V Fin, chrome	429.95

PART #	DESCRIPTION	SUG. RETAIL
<b>FOR 07-17 XL MODELS</b>		
1001-0049	Finned, black anodized	\$429.95
1001-0050	Finned, black anodized/silver accents	429.95
1001-0051	Finned, chrome	429.95
1001-0052	Smooth, black anodized	429.95
1001-0053	Smooth, chrome	429.95
1001-0054	Tech, black anodized	429.95
1001-0055	Tech, black anodized/silver accents	429.95
1001-0056	Tech, chrome	429.95
1001-0057	V Fin, black anodized	429.95
1001-0058	V Fin, black anodized/silver accents	429.95
1001-0059	V Fin, chrome	429.95



1010-0926

1010-0927

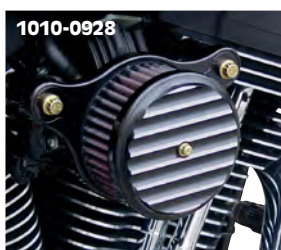

1010-0928



1010-0929



1010-1010



1010-0941

1010-0942

**HIGH-PERFORMANCE AIR CLEANER ASSEMBLIES**

- Super-clean design features all-CNC-machined billet aluminum construction throughout
- Equipped with a genuine K&N 4" diameter high-flow filter
- Has Joker's exclusive "baffle plate" crankcase breathing system, held all together with high-strength 12-point alloy mounting bolts
- Improves leg clearance over the stock air cleaner assembly due to its compact design
- Available in your choice of hard black anodized or chrome-plated finishes
- Made in the U.S.A.

PART #	DESCRIPTION	SUG. RETAIL
<b>FOR 01-17 TWIN CAM W/ DELPHI EFI, 99-06 TWIN CAM W/ CV CARB (EXCEPT 08-17 FLHT/FLHR/FLHX/FLTR, HD FL TRIKE, 16-17 SOFTTAILS, 14-15 FLSTNSE, 13-14 FXSBSE, 11-12 FLTSE AND 16-17 FXDLS)</b>		
1010-0926	Smooth black anodized	\$290.95
1010-0927	Smooth chrome	300.95
1010-0928	Finned black anodized	290.95
1010-0929	Finned chrome	300.95
1010-1007	Joker Racing, black anodized	290.95
1010-1010	JM U.S.A., black anodized	290.95
<b>FOR 07-17 XL MODELS</b>		
1010-0930	Finned black anodized	250.95
1010-0931	Finned chrome	260.95
1010-0941	Joker Racing, black anodized	250.95

PART #	DESCRIPTION	SUG. RETAIL
<b>FOR 07-17 XL MODELS (CONT)</b>		
1010-0942	Joker Racing, chrome	\$260.95
1010-0692	Smooth, black anodized	250.95
1010-0693	Smooth, chrome	260.95
1010-0694	Smooth, clear anodized	250.95
<b>FOR 91-06 XL MODELS W/ CV CARB</b>		
1010-0932	Finned black anodized	250.95
1010-0933	Finned chrome	260.95
1010-0943	Joker Racing, black	250.95
1010-0695	Smooth, black anodized	250.95
1010-0697	Smooth, clear anodized	250.95
<b>REPLACEMENT FILTER</b>		
1011-3217	K&N repl. filter	50.95

**RAIN SOCK FOR JOKER AIR CLEANERS**

- Water-repellent prefilter custom-made by Outerwears for riding in rainy weather
- Fits all Joker Machine air cleaners with 4" K&N filters
- Easy installation - attaches with hook-and-loop for easy installation and removal
- Made in the U.S.A.

PART #	DESCRIPTION	SUG. RETAIL
1011-2938	Air filter rain sock	\$13.95



**DISCLAIMER:** NOT LEGAL FOR SALE OR USE IN CALIFORNIA ON ANY POLLUTION CONTROLLED MOTOR VEHICLES. SEE PAGE 399 FOR IMPORTANT EMISSION DEFINITIONS AND REGULATORY COMPLIANCE AND WARRANTY INFORMATION.

All part numbers in BLUE are new for 2017.

WINDSHIELDS & FAIRINGS

AUDIO & VIDEO

SADDLEBAGS & LUGGAGE

SEATS & SISSY BARS

EXHAUST

FUEL/AIR SYSTEMS

ENGINE

TRANSMISSION & DRIVELINE

GASKETS & SEALS

ELECTRICAL

LIGHTING

HANDLEBARS, CONTROLS & MIRRORS

CABLES

BRAKES

TANKS & OIL FILTERS

DASHES & GAUGES

FRAMES & SUSPENSION

FENDERS & LICENSE PLATE FRAMES

FOOTRESTS

WHEELS & AXLES

HARDWARE, COVERS & GENERAL

WINDSHIELDS & FAIRINGS

AUDIO & VIDEO

SADDLEBAGS & LUGGAGE

SEATS & SISSY BARS

EXHAUST

FUEL/AIR SYSTEMS

ENGINE

TRANSMISSION & DRIVELINE

GASKETS & SEALS

ELECTRICAL

LIGHTING

HANDLEBARS, CONTROLS & MIRRORS

CABLES

BRAKES

TANKS & OIL FILTERS

DASHES & GAUGES

FRAMES & SUSPENSION

FENDERS & LICENSE PLATE FRAMES

FOOTRESTS

WHEELS & AXLES

HARDWARE, COVERS & GENERAL



**TRI-BAR AIRCLEANER**

- Timeless round design with a high-flow, ultra low-profile air filter
- 1<sup>1</sup>/<sub>4</sub>" thinner than stock, while flowing significantly more air
- Ultra-low profile design for maximum leg clearance
- Ultra-Flow filter produces a massive 45% increase in air flow over a 2014 OEM air filter
- Innovative design incorporates an OEM-style crankcase breather
- Patent pending



PART #	DESCRIPTION	SUG. RETAIL
<b>FOR 08-16 FLHT/FLHR/FLHX/FLTR, 16-17 SOFTTAILS, 16-17 FXDLS</b>		
1010-1868	Black	\$299.95

PART #	DESCRIPTION	SUG. RETAIL
<b>FOR 08-16 FLHT/FLHR/FLHX/FLTR, 16-17 SOFTTAILS, 16-17 FXDLS (CONT)</b>		
1010-1869	Chrome	\$299.95

**RADIAL AIR CLEANERS**

- Aluminum body features a unique cover with brass pushrods and precision machined engine components
- Ultra-low profile design for maximum leg clearance
- Designed for high flow and features a performance air filter
- Ultra-Flow filter produces a massive 45% increase in air flow over a 2014 OEM air filter
- The innovative design incorporates an OEM style crankcase breather
- Patent pending



PART #	DESCRIPTION	SUG. RETAIL
<b>FOR 08-16 FLHT/FLHR/FLHX/FLTR, 16-17 SOFTTAILS, 16-17 FXDLS</b>		
1010-1875	Black	\$389.95

PART #	DESCRIPTION	SUG. RETAIL
<b>FOR 08-16 FLHT/FLHR/FLHX/FLTR, 16-17 SOFTTAILS, 16-17 FXDLS (CONT)</b>		
1010-1876	Chrome	\$389.95



**CIPHER AIR CLEANERS**

- Ultra-low profile design for maximum leg clearance
- Customizable front blades allow a wide variety of styles
- Ultra-flow filter produces a massive 45% increase in airflow over a 2014 OEM air filter
- The innovative design incorporates an OEM style crankcase breather
- Simple bolt-on installation
- Patent pending



PART #	DESCRIPTION	SUG. RETAIL
<b>FOR 08-16 FLHT/FLHR/FLTR/FLHX, 16-17 SOFTTAILS, 16-17 FXDLS</b>		
1010-1871	Chrome w/ silver brushed blades	\$299.95
1010-1872	Black w/ black carbon fiber blades	389.95

PART #	DESCRIPTION	SUG. RETAIL
<b>FOR 08-16 FLHT/FLHR/FLTR/FLHX, 16-17 SOFTTAILS, 16-17 FXDLS (CONT)</b>		
1010-1873	Chrome w/ black carbon fiber blades	\$299.95
1010-1874	Black w/ chrome blades	299.95

**DISCLAIMER:** NOT LEGAL FOR SALE OR USE IN CALIFORNIA ON ANY POLLUTION CONTROLLED MOTOR VEHICLES. SEE PAGE 399 FOR IMPORTANT EMISSION DEFINITIONS AND REGULATORY COMPLIANCE AND WARRANTY INFORMATION.

All part numbers in **BLUE** are new for 2017.



1010-1657



1010-1659

1010-1654

1010-1655

**FUSION AIR CLEANER ASSEMBLIES**

- Extreme CNC-machined design
- Artistic chrome, Decadent black powdercoat and Laser satin black with laser-etched accent finishes available
- Air filter design eliminates the red pre-oiled look with a more satisfying black oil and stainless steel mesh blend
- Thinner profile creates more leg room
- Design still flows huge volume of air that will feed the biggest engines
- Made in the U.S.A.

PART #	DESCRIPTION	SUG. RETAIL
<b>FOR 01-17 TWIN CAM W/ DELPHI EFI (EXCEPT 08-17 FLHT/FLHR/FLTR/FLHX/H-D FL TRIKES AND 16-17 SOFTTAILS, 16-17 FXDLS, 14-15 FLSTNSE, 13-14 FXSBSE AND 11-12 FLTSTSE), 93-06 BIG TWIN W/ CV CARBURETOR</b>		
1010-1657	Artistic chrome	\$349.95
1010-1658	Decadent black powdercoat	349.95
1010-1659	Laser satin black	349.95

PART #	DESCRIPTION	SUG. RETAIL
<b>FOR 08-16 FLHT/FLHR/FLTR/FLHX /H-D FL TRIKES AND 16-17 SOFTTAILS, 16-17 FXDLS, 14-15 FLSTNSE, 13-14 FXSBSE AND 11-12 FLTSTSE</b>		
1010-1660	Artistic chrome	\$349.95
1010-1661	Decadent black powdercoat	349.95
1010-1662	Laser satin black	349.95

PART #	DESCRIPTION	SUG. RETAIL
<b>FOR 91-17 XL W/ DELPHI EFI OR CV CARBURETOR</b>		
1010-1654	Artistic chrome	\$349.95
1010-1655	Decadent black powdercoat	349.95
1010-1656	Laser satin black	349.95
<b>REPLACEMENT COMPONENTS</b>		
1011-3628	Black air filter element	39.95

**AIR CLEANER ASSEMBLIES**

- Machined from 6061 T-6 billet aluminum
- Kit replaces the OEM air cleaner assembly, maintaining balance and symmetry
- Custom-made AirRaid air filter provides increased airflow volume to the engine
- Dyno-designed AirLoad backing plate reduces turbulence and increases air intake velocity, boosting horsepower and torque
- Covers are triple chrome-plated or textured black powdercoat with laser-cut design
- Exposes more of the engine and brings out its aggressive nature
- New low-profile black air filter element
- Complete hardware kit and instructions included for easy installation
- Made in the U.S.A.



1010-1823

1010-1825

1010-1834

1010-1837

1010-1843

1010-1849

PART #	DESCRIPTION	SUG. RETAIL
<b>FOR 08-16 FLHT/FLHR/FLTR/FLHX, H-D FL TRIKES 16-17 SOFTTAILS, 16-17 FXDLS, 14-15 FLSTNSE, 13-14 FXSBSE AND 11-12 FLTSTSE MODELS</b>		
1010-1823	xXx, chrome	\$299.95
1010-1826	xXx, black	299.95
1010-1835	Standard cross, chrome	299.95
1010-1838	Standard cross, black	299.95
1010-1841	Spanish cross, chrome	299.95
1010-1844	Spanish cross, black	299.95
1010-1847	Celtic cross, chrome	379.95
1010-1850	Celtic cross, black	379.95

PART #	DESCRIPTION	SUG. RETAIL
<b>FOR 01-17 TWIN CAM W/ DELPHI EFI (EXCEPT 08-17 FLHT/FLHR/FLTR/FLHX, H-D FL TRIKES, 16-17 SOFTTAILS, 16-17 FXDLS, 14-15 FLSTNSE, 13-14 FXSBSE AND 11-12 FLTSTSE MODELS), 93-06 BIG TWIN W/ CV CARB</b>		
1010-1822	xXx, chrome	\$299.95
1010-1825	xXx, black	299.95
1010-1834	Standard cross, chrome	299.95
1010-1837	Standard cross, black	299.95
1010-1840	Spanish cross, chrome	299.95
1010-1843	Spanish cross, black	299.95
1010-1846	Celtic cross, chrome	379.95
1010-1849	Celtic cross, black	379.95

PART #	DESCRIPTION	SUG. RETAIL
<b>FOR 91-17 XL W/ CV CARBURETOR OR DELPHI EFI</b>		
1010-1824	xXx, chrome	\$299.95
1010-1827	xXx, black	299.95
1010-1836	Standard cross, chrome	299.95
1010-1839	Standard cross, black	299.95
1010-1842	Spanish cross, chrome	299.95
1010-1845	Spanish cross, black	299.95
1010-1848	Celtic cross, chrome	379.95
1010-1851	Celtic cross, black	379.95
<b>REPLACEMENT COMPONENTS</b>		
1011-3628	Black air filter element	39.95

**AFFLICTION AIR CLEANERS**

- Affliction has teamed up with LA Choppers to create the perfect marriage of performance and style
- Backing plate machined from 6061 T-6 billet aluminum and available in chrome or black
- Provide quicker, smoother, stronger acceleration
- Kit replaces the OEM air cleaner assembly, maintaining balance and symmetry
- Custom-made AirRaid filter provides increased airflow volume to the engine
- Dyno-designed AirLoad backing plate reduces turbulence and increases air intake velocity, boosting horsepower and torque
- Expose more of the engine and bring out its aggressive nature
- New low-profile black air filter element
- Complete hardware kit and instructions included for easy installation
- Made in the U.S.A.



1010-1829

1010-1830

PART #	DESCRIPTION	SUG. RETAIL
<b>CHROME</b>		
1010-1830	For 08-16 FLHT/FLHR/FLTR/FLHX, H-D FL Trikes, 16-17 Softtails, 16-17 FXDLS, 14-15 FLSTNSE, 13-14 FXSBSE and 11-12 FLTSTSE models	\$299.95
1010-1828	For 01-17 Twin Cam w/ Delphi EFI, 93-06 Big Twin w/ CV carb (except 08-17 Dresser, H-D FL Trikes, 16-17 Softtails, 16-17 FXDLS, 14-15 FLSTNSE, 13-14 FXSBSE and 11-12 FLTSTSE models)	299.95
1010-1832	For 91-17 XL w/ CV carburetor or Delphi EFI	299.95

PART #	DESCRIPTION	SUG. RETAIL
<b>BLACK</b>		
1010-1831	For 08-16 FLHT/FLHR/FLTR/FLHX, H-D FL Trikes, 16-17 Softtails, 16-17 FXDLS, 14-15 FLSTNSE, 13-14 FXSBSE and 11-12 FLTSTSE models	\$299.95
1010-1829	For 01-17 Twin Cam w/ Delphi EFI, 93-06 Big Twin w/ CV carb (except 08-17 Dresser/H-D FL Trikes, 16-17 Softtails, 16-17 FXDLS, 14-15 FLSTNSE, 13-14 FXSBSE and 11-12 FLTSTSE models)	299.95
1010-1833	For 91-17 XL w/ CV carburetor or Delphi EFI	299.95
<b>REPLACEMENT COMPONENT</b>		
1011-3628	Black air filter element	39.95

**DISCLAIMER:** NOT LEGAL FOR SALE OR USE IN CALIFORNIA ON ANY POLLUTION CONTROLLED MOTOR VEHICLES. SEE PAGE 399 FOR IMPORTANT EMISSION DEFINITIONS AND REGULATORY COMPLIANCE AND WARRANTY INFORMATION.

All part numbers in BLUE are new for 2017.

WINDSHIELDS & FAIRINGS

AUDIO & VIDEO

SADDLEBAGS & LUGGAGE

SEATS & SISSY BARS

EXHAUST

FUEL/AIR SYSTEMS

ENGINE

TRANSMISSION & DRIVELINE

GASKETS & SEALS

ELECTRICAL

LIGHTING

HANDLEBARS, CONTROLS & MIRRORS

CABLES

BRAKES

TANKS & OIL FILTERS

DASHES & GAUGES

FRAMES & SUSPENSION

FENDERS & LICENSE PLATE FRAMES

FOOTRESTS

WHEELS & AXLES

HARDWARE, COVERS & GENERAL

WINDSHIELDS & FAIRINGS

AUDIO & VIDEO

SADDLEBAGS & LUGGAGE

SEATS & SISSY BARS

EXHAUST

FUEL/AIR SYSTEMS

ENGINE

TRANSMISSION & DRIVELINE

GASKETS & SEALS

ELECTRICAL

LIGHTING

HANDLEBARS, CONTROLS & MIRRORS

CABLES

BRAKES

TANKS & OIL FILTERS

DASHES & GAUGES

FRAMES & SUSPENSION

FENDERS & LICENSE PLATE FRAMES

FOOTRESTS

WHEELS & AXLES

HARDWARE, COVERS & GENERAL



Smooth



Flame



Comet



Enferno



Pinstripe (chrome)



Pinstripe (black)



Danni Doll Pinup

**BIG AIR KIT (BAK)**

- Flow-bench and dyno-designed for substantially increased horsepower and torque
- Features beautifully chromed or powdercoat black billet covers in your choice of designs
- Innovative styling enhances and accentuates your "V" Twin engine
- Set-back, thin-line design does not interfere with rider's leg
- Slim 1 1/2" hi-flow reusable filter and specially designed back plate dynamically increases air flow and velocity
- Maximizes overall performance and fuel efficiency
- Easily supports engines producing over 120 HP
- Complete with breather kit, mounting hardware and micron-fabric raincoat for wet-weather riding
- Easy-to-follow instructions included for a do-it-yourself install
- Made in the U.S.A.



Standard cross



Spanish cross



Celtic cross



Smooth black

PART #	DESCRIPTION	SUG. RETAIL
<b>08-16 FLHT/FLHR/FLTR/FLHX /H-D FL TRIKES, 16-17 SOFTTAILS, 16-17 FXDLS, 14-15 FLSTNSE, 13-14 FXSBSE AND 11-12 FLTSE</b>		
1010-0482	Smooth	\$309.95
1010-0527	Flame	309.95
1010-0528	Comet	309.95
1010-0529	Enferno	309.95
1010-0567	Pinstripe (chrome)	309.95
1010-0569	Pinstripe (black)	309.95
1010-1165	Danni Doll pinup	399.95
1010-1169	Standard cross	309.95
1010-1170	Spanish cross	309.95

PART #	DESCRIPTION	SUG. RETAIL
<b>08-16 FLHT/FLHR/FLTR/FLHX /H-D FL TRIKES, 16-17 SOFTTAILS, 16-17 FXDLS, 14-15 FLSTNSE, 13-14 FXSBSE AND 11-12 FLTSE (CONT)</b>		
1010-1171	Celtic cross	\$329.95
1010-1316	Smooth, black	309.95
<b>FOR 01-17 TWIN CAM W/ DELPHI EFI (EXCEPT 08-17 DRESSERS/H-D FL TRIKES, 16-17 SOFTTAILS, 16-17 FXDLS, 14-15 FLSTNSE, 13-14 FXSBSE AND 11-12 FLTSE), 93-06 BIG TWIN W/ CV CARB</b>		
1010-0481	Smooth	309.95
1010-0524	Flame	309.95
1010-0525	Comet	309.95

PART #	DESCRIPTION	SUG. RETAIL
<b>FOR 01-17 TWIN CAM W/ DELPHI EFI (EXCEPT 08-17 DRESSERS/H-D FL TRIKES, 16-17 SOFTTAILS, 16-17 FXDLS, 14-15 FLSTNSE, 13-14 FXSBSE AND 11-12 FLTSE), 93-06 BIG TWIN W/ CV CARB (CONT)</b>		
1010-0526	Enferno	\$309.95
1010-0566	Pinstripe (chrome)	309.95
1010-0568	Pinstripe (black)	309.95
1010-1164	Danni Doll pinup	399.95
1010-1166	Standard cross	309.95
1010-1167	Spanish cross	309.95
1010-1168	Celtic cross	329.95
1010-1315	Smooth, black	309.95

**REPLACEMENT AIR FILTER FOR ORIGINAL STYLE LA CHOPPERS AIR CLEANER ASSEMBLY KITS AND AFFLICTION AIR CLEANERS**

- Replacement larger profile red air filter elements for original style LA Choppers Air Cleaner Assembly kits and Affliction Air Cleaners and for current air cleaners using the the new style low-profile black air filter element
- Made in the U.S.A.



1011-2052



**AIR CLEANER CONVERSION KIT**

- Kit allows use of new style black air filter element PART #1011-3628 with old-style LA Chopper air cleaner assemblies that used the red air filter element
- Made in the U.S.A.

PART #	DESCRIPTION	SUG. RETAIL
1011-2052	For 08-16 FLHT/FLHR/FLTR/FLHX, H-D FL Trikes, 16-17 Softtails, 16-17 FXDLS, 14-15 FLSTNSE, 13-14 FXSBSE and 11-12 FLTSE models (6.5" diameter)	\$59.95
1011-2053	For 01-17 Twin Cam w/ Delphi EFI, 93-06 Big Twin w/ CV carb (except 08-17 Dresser, H-D FL Trikes, 16-17 Softtails, 16-17 FXDLS, 14-15 FLSTNSE, 13-14 FXSBSE and 11-12 FLTSE models) (8" diameter)	36.95
1011-3628	Repl. black air filter element	39.95

PART #	DESCRIPTION	SUG. RETAIL
1010-1852	Conversion kit	\$54.95



Danni Doll Pinup



Smooth



Smooth black



Flame



Comet



Enferno



Chrome pinstripe



1011-2940

1011-2941



Black Pinstripe



Standard cross



Spanish cross



Celtic cross

**BAK REPLACEMENT COVERS**

- For those wanting to alter the look of their BAK or replace a damaged cover
- Cover only, does not include hardware

PART #	DESCRIPTION	SUG. RETAIL	PART #	DESCRIPTION	SUG. RETAIL	PART #	DESCRIPTION	SUG. RETAIL
1014-0076	Danni Doll pinup	\$219.95	1014-0148	Comet	\$119.95	1014-0154	Standard cross	\$119.95
1014-0146	Smooth	119.95	1014-0149	Enferno	119.95	1014-0155	Spanish cross	119.95
1014-0164	Smooth black	119.95	1014-0152	Chrome pinstripe	119.95	1014-0156	Celtic cross	139.95
1014-0147	Flame	119.95	1014-0153	Black pinstripe	119.95			



**RAINCOATS FOR BAK**

- Protect your BAK filter from moisture and dust
- BAK filters are water resistant, but extended riding in rain is not recommended
- Classic fits 2" W filter
- Slim fits 1 1/2" filter
- Classic will also work on any filter kit that uses a K&N E-3333 filter (does not fit K&N billet filter kits)

PART #	DESCRIPTION	SUG. RETAIL
1011-2940	Classic	\$19.95
1011-2941	Slim	19.95

**DISCLAIMER:** NOT LEGAL FOR SALE OR USE IN CALIFORNIA ON ANY POLLUTION CONTROLLED MOTOR VEHICLES.

SEE PAGE 399 FOR IMPORTANT EMISSION DEFINITIONS AND REGULATORY COMPLIANCE AND WARRANTY INFORMATION.

All part numbers in BLUE are new for 2017.



1010-1677



1010-1685



1010-1689

**AIRSTRIKE AIR CLEANERS**

- Designed to match RC Components wheel designs
- CNC machined out of billet aluminum
- Backing plate features built-in breather ports
- Include a K&N high-flow, reusable filter element
- Available in show-quality chrome or Eclipse black finish
- Include all necessary hardware and gaskets
- Made in the U.S.A.

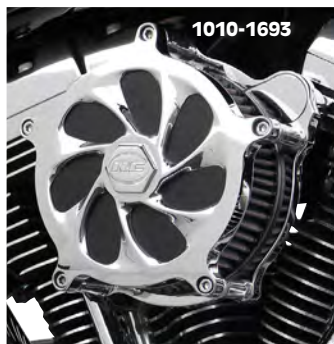

1010-1693



1010-1697



1010-1701

PART #	DESCRIPTION	SUG. RETAIL
<b>FOR 08-16 FLHR/FLHT/FLHX/FLTRX/FL TRIKE, 16-17 FXDLS, 16-17 SOFTTAILS, 14-15 FLSTNSE, 13-14 FXSBSE AND 11-12 FLTSE MODELS</b>		
1010-1677	Majestic Chrome	\$429.95
1010-1680	Majestic Eclipse	429.95
1010-1685	Savage Chrome	429.95
1010-1689	Savage Eclipse	429.95
1010-1693	Drifter Chrome	429.95
1010-1697	Nitro Chrome	429.95
1010-1701	Recoil Chrome	429.95
<b>FOR 08-16 FLHR/FLHT/FLHX/FLTRX/FL TRIKE, 16-17 FXDLS, 16-17 SOFTTAILS MODELS W/ 58 MM SE THROTTLE BODY</b>		
1010-1681	Majestic Chrome	429.95
1010-1684	Majestic Eclipse	429.95
1010-1688	Savage Chrome	429.95
1010-1692	Savage Eclipse	429.95
1010-1696	Drifter Chrome	429.95
1010-1700	Nitro Chrome	429.95
1010-1704	Recoil Chrome	429.95

PART #	DESCRIPTION	SUG. RETAIL
<b>FOR 93-06 BIG TWIN MODELS W/ STOCK CV CARB, 02-07 FLT MODELS W/ DELPHI EFI, 01-15 SOFTTAIL MODELS, 04-17 DYNA GLIDE MODELS (EXCEPT FXDLS)</b>		
1010-1678	Majestic Chrome	\$429.95
1010-1682	Majestic Eclipse	429.95
1010-1686	Savage Chrome	429.95
1010-1690	Savage Eclipse	429.95
1010-1694	Drifter Chrome	429.95
1010-1698	Nitro Chrome	429.95
1010-1702	Recoil Chrome	429.95
<b>FOR 91-17 XL MODELS</b>		
1010-1679	Majestic Chrome	429.95
1010-1683	Majestic Eclipse	429.95
1010-1687	Savage Chrome	429.95
1010-1691	Savage Eclipse	429.95
1010-1695	Drifter Chrome	429.95
1010-1699	Nitro Chrome	429.95
1010-1703	Recoil Chrome	429.95



1010-1392



1010-1394



1010-1395



**TRUFLO AIR CLEANERS**

- Custom front flow design maximizes airflow and performance
- Stylish low profile design
- Include a K&N high flow, reusable filter element
- CNC machined out of billet aluminum
- Backing plate features built-in breather ports
- Available in show quality chrome or black powdercoat
- Include all necessary hardware and gaskets
- Made in the U.S.A.

PART #	DESCRIPTION	SUG. RETAIL
<b>FOR 08-16 FLT/FLHT/FL TRIKE, 16-17 FXDLS, 16-17 SOFTTAILS, 14-15 FLSTNSE, 13-14 FXSBSE AND 11-12 FLTSE MODELS</b>		
1010-1392	Gatlin chrome finish	\$429.95
1010-1393	Blitz chrome finish	429.95
1010-1394	Gatlin black finish	429.95
1010-1395	Blitz black finish	429.95

PART #	DESCRIPTION	SUG. RETAIL
<b>FOR 93-06 BIG TWIN MODELS W/ STOCK CV CARB, 02-07 FLT MODELS W/ DELPHI EFI, 01-15 SOFTTAIL MODELS, 04-17 DYNA GLIDE MODELS (EXCEPT FXDLS)</b>		
1010-1396	Gatlin chrome finish	\$429.95
1010-1397	Blitz chrome finish	429.95
1010-1398	Gatlin black finish	429.95
1010-1399	Blitz black finish	429.95

PART #	DESCRIPTION	SUG. RETAIL
<b>FOR 91-17 XL MODELS W/ CV CARB/DELPHI EFI</b>		
1010-1400	Gatlin chrome finish	\$429.95
1010-1401	Blitz chrome finish	429.95
1010-1402	Gatlin black finish	429.95
1010-1403	Blitz black finish	429.95

**DISCLAIMER:** NOT LEGAL FOR SALE OR USE IN CALIFORNIA ON ANY POLLUTION CONTROLLED MOTOR VEHICLES. SEE PAGE 399 FOR IMPORTANT EMISSION DEFINITIONS AND REGULATORY COMPLIANCE AND WARRANTY INFORMATION.

All part numbers in **BLUE** are new for 2017.



- WINDSHIELDS & FAIRINGS
- AUDIO & VIDEO
- SADDLEBAGS & LUGGAGE
- SEATS & SISSY BARS
- EXHAUST

FUEL/AIR SYSTEMS

- ENGINE
- TRANSMISSION & DRIVELINE

- GASKETS & SEALS

- ELECTRICAL

- LIGHTING

- HANDLEBARS, CONTROLS & MIRRORS

- CABLES

- BRAKES

- TANKS & OIL FILTERS

- DASHES & GAUGES

- FRAMES & SUSPENSION

- FENDERS & LICENSE PLATE FRAMES

- FOOTRESTS

- WHEELS & AXLES

- HARDWARE, COVERS & GENERAL

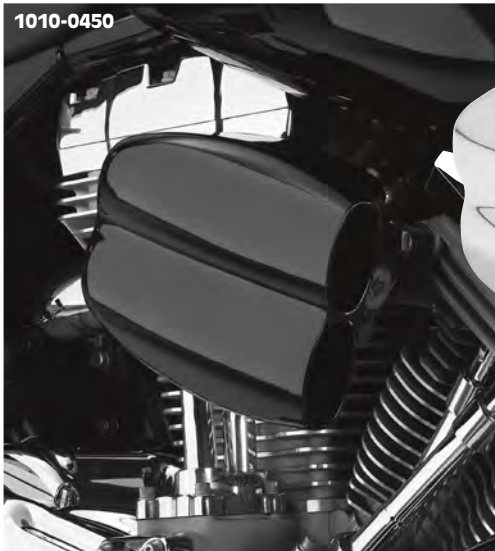

**MO-FLOW™ BILLET AIR CLEANERS**

- Made from aluminum, polished and chrome-plated
- Available in gloss black, chrome or wrinkle black powder coat
- Hidden fasteners and internal breather assembly make for a clean look
- Each air cleaner assembly contains a reusable pleated gauze performance filter that has been engineered and flow tested to obtain maximum flow and protection for your motor
- Seal breather assembly velocity plate and all necessary mounting hardware included
- Optional hardware kits available separately and only work with Cycle Visions Mo-Flow air cleaners



NOTE: Some applications exempt per CARB EXECUTIVE ORDER (E.O.) No. D-668-1, for 00-16 EFI applications

NOTE: Adapter for Mikuni carbs sold separately.

PART #	DESCRIPTION	SUG. RETAIL
<b>GLOSS BLACK</b>		
1010-0450	For 08-16 FLHT/FLHR/FLHX/FLTR/H-D FL Trikes, 16-17 Softails, 14-15 FLSTNSE, 13-14 FXSBSE and 11-12 FLSTSE and 16-17 FXDLS	\$299.95
1010-0445 <sup>1</sup>	For 99-06 Twin Cam w/ CV or HSR Mikuni carb, 01-17 Twin Cam w/ Delphi EFI (except 08-17 Dressers, 16-17 Softails, 14-15 FLSTNSE, 13-14 FXSBSE and 11-12 FLSTSE and 16-17 FXDLS)	299.95
1010-0444 <sup>1</sup>	For 93-99 Evolution Big Twin w/ CV or HSR Mikuni carbs	299.95
1010-0446 <sup>1</sup>	For 91-17 XL w/ CV carb or HSR Mikuni carb/Delphi EFI	299.95
<b>CHROME</b>		
1010-0349	For 08-16 FLHT/FLHR/FLHX/FLTR/H-D FL Trikes, 16-17 Softails, 14-15 FLSTNSE, 13-14 FXSBSE and 11-12 FLSTSE and 16-17 FXDLS	299.95
1010-0270 <sup>1</sup>	For 99-06 Twin Cam w/ CV or HSR Mikuni carb, 01-17 Twin Cam w/ Delphi EFI (except 08-17 Dressers, 16-17 Softails, 14-15 FLSTNSE, 13-14 FXSBSE and 11-12 FLSTSE and 16-17 FXDLS)	299.95
1010-0210 <sup>1</sup>	For 93-99 Evolution Big Twin w/ CV or HSR Mikuni carbs	299.95
1010-0272	For 93-99 Evolution Big Twin w/ S&S E or G carb	299.95
1010-0212 <sup>1</sup>	For 91-17 XL w/ CV carb or HSR Mikuni carb/Delphi EFI	299.95

PART #	DESCRIPTION	SUG. RETAIL
<b>WRINKLED BLACK POWDER-COAT</b>		
1010-0350	For 08-16 FLHT/FLHR/FLHX/FLTR/H-D FL Trikes, 16-17 Softails, 14-15 FLSTNSE, 13-14 FXSBSE and 11-12 FLSTSE and 16-17 FXDLS	\$299.95
1010-0301 <sup>1</sup>	For 99-06 Twin Cam w/ CV or HSR Mikuni carb, 01-17 Twin Cam w/ Delphi EFI (except 08-17 Dressers, 16-17 Softails, 14-15 FLSTNSE, 13-14 FXSBSE and 11-12 FLSTSE and 16-17 FXDLS )	299.95
1010-0298 <sup>1</sup>	For 93-99 Evolution Big Twin w/ CV or HSR Mikuni carbs	299.95
1010-0300 <sup>1</sup>	For 91-17 XL w/ CV carb or HSR Mikuni carb/Delphi EFI	299.95
<b>REPLACEMENT HARDWARE KITS</b>		
1010-0834	For 08-16 FLHT/FLHR/FLHX/FLTR/H-D FL Trikes	36.95
1010-0832	For 93-99 Evolution Big Twin (all)	36.95
1010-0833	For 99-06 Twin Cam (all)	36.95
1010-0832	For 91-17 XL (all)	36.95
<b>REPLACEMENT AIR FILTER</b>		
1011-2002	Repl. air filter	59.95

<sup>1</sup> Requires adapter for Mikuni.



**MOTO INTAKE KITS**

- CNC-machined aluminum construction
- Increases airflow while maintaining a low profile
- Cleanable/reusable proprietary air filter has over 130 sq. in. of filter element
- Internal velocity stack with internal breathers breathe directly back into venturi
- Made in the U.S.A.



PART #	DESCRIPTION	SUG. RETAIL
<b>FOR 01-15 SOFTAIL, 04-17 DYNA (EXCEPT FXDLS), 02-07 FLT/FLHT WITH DELPHI EFI, 93-06 BIG TWIN W/ STOCK CV CARB</b>		
1010-0714	Chrome	\$371.95
1010-0715	Black anodized	371.95

**DISCLAIMER:** NOT LEGAL FOR SALE OR USE IN CALIFORNIA ON ANY POLLUTION CONTROLLED MOTOR VEHICLES. SEE PAGE 399 FOR IMPORTANT EMISSION DEFINITIONS AND REGULATORY COMPLIANCE AND WARRANTY INFORMATION.

All part numbers in **BLUE** are new for 2017.



WINDSHIELDS & FAIRINGS

AUDIO & VIDEO

SADDLEBAGS & LUGGAGE

SEATS & SISSY BARS

EXHAUST

FUEL/AIR SYSTEMS

ENGINE

TRANSMISSION & DRIVELINE

GASKETS & SEALS

ELECTRICAL

LIGHTING

HANDLEBARS, CONTROLS & MIRRORS

CABLES

BRAKES

TANKS & OIL FILTERS

DASHES & GAUGES

FRAMES & SUSPENSION

FENDERS & LICENSE PLATE FRAMES

FOOTRESTS

WHEELS & AXLES

HARDWARE, COVERS & GENERAL



**RPT AIR INTAKES**

- Same internal components as the Cobra Powerflo air intake, with the outside cover replaced with a machined aluminum industrial-looking frame that echoes Cobra's popular Race Pro mufflers
- Unique internal venturi design promotes maximum airflow
- High-flow K&N® air filter element ensures the best air intake and maximum protection for your engine
- Includes all the fasteners, seals, backing plate and mounting hardware to make for an easy installation
- Formed stainless steel mesh insert keeps out bugs and debris
- Made in the U.S.A.

PART #	DESCRIPTION	SUG. RETAIL
<b>FOR 08-16 FLHT/FLHR/FLHX/FLTR/H-D FL TRIKE, 16-17 FXDLS, 16-17 SOFTTAILS, 14-15 FLSTNSE, 13-14 FXSBSE and 11-12 FLSTSE</b>		
1010-1954	Chrome	\$399.95
1010-1955	Black	399.95
1010-1956	Black ring w/ chrome frame	399.95
1010-1957	Chrome ring w/ black frame	399.95
<b>FOR 99-17 TWIN CAM W/ CV CARB/DELPHI EFI (EXCEPT 08-17 DRESSER/H-D FL TRIKE, 16-17 FXDLS, 16-17 SOFTTAILS, 14-15 FLSTNSE, 13-14 FXSBSE and 11-12 FLSTSE)</b>		
1010-1958	Chrome	399.95
1010-1959	Black	399.95
1010-1960	Black ring w/ chrome frame	399.95

PART #	DESCRIPTION	SUG. RETAIL
<b>FOR 99-17 TWIN CAM W/ CV CARB/DELPHI EFI (EXCEPT 08-17 DRESSER/H-D FL TRIKE, 16-17 FXDLS, 16-17 SOFTTAILS, 14-15 FLSTNSE, 13-14 FXSBSE and 11-12 FLSTSE) (CONT)</b>		
1010-1961	Chrome ring w/ black frame	\$399.95
<b>FOR 04-17 XL W/ CV CARB/DELPHI EFI</b>		
1010-1962	Chrome	399.95
1010-1963	Black	399.95
1010-1964	Black ring w/ chrome frame	399.95
1010-1965	Chrome ring w/ black frame	399.95
<b>REPLACEMENT COMPONENT</b>		
1011-3834	Replacement K&N filter	74.95



**POWRFLO AIR INTAKE**

- Unique internal venturi design promotes maximum airflow
- High-flow K&N® air filter element ensures the best air intake and maximum protection for your engine
- The PowrFlo Intake system consists of an aluminum cover and all the fasteners, seals, backing plate and mounting hardware to make for an easy installation
- Formed stainless steel mesh insert in the dual entry ports keeps out bugs and debris
- Available in black or chrome finish

PART #	DESCRIPTION	SUG. RETAIL
<b>FOR 08-16 FLHT/FLHR/FLHX/FLTR/H-D FL TRIKE, 16-17 FXDLS, 16-17 SOFTTAILS, 14-15 FLSTNSE, 13-14 FXSBSE and 11-12 FLSTSE</b>		
1010-0814	Chrome	\$279.95
1010-0815	Black	279.95
<b>FOR 99-17 TWIN CAM W/ CV CARB/DELPHI EFI (EXCEPT 08-17 DRESSER/H-D FL TRIKE, 16-17 FXDLS, 16-17 SOFTTAILS, 14-15 FLSTNSE, 13-14 FXSBSE and 11-12 FLSTSE)</b>		
1010-0816	Chrome	279.95
1010-0817	Black	279.95

PART #	DESCRIPTION	SUG. RETAIL
<b>FOR 04-17 XL W/ CV CARB/DELPHI EFI</b>		
1010-0894	Chrome	\$279.95
1010-0895	Black	279.95
<b>REPLACEMENT COMPONENT</b>		
1011-3834	Replacement K&N filter	74.95

**DISCLAIMER:** NOT LEGAL FOR SALE OR USE IN CALIFORNIA ON ANY POLLUTION CONTROLLED MOTOR VEHICLES. SEE PAGE 399 FOR IMPORTANT EMISSION DEFINITIONS AND REGULATORY COMPLIANCE AND WARRANTY INFORMATION.

All part numbers in BLUE are new for 2017.

WINDSHIELDS & FAIRINGS

AUDIO & VIDEO

SADDLEBAGS & LUGGAGE

SEATS & SISSY BARS

EXHAUST

FUEL/AIR SYSTEMS

ENGINE

TRANSMISSION & DRIVELINE

GASKETS & SEALS

ELECTRICAL

LIGHTING

HANDLEBARS, CONTROLS & MIRRORS

CABLES

BRAKES

TANKS & OIL FILTERS

DASHES & GAUGES

FRAMES & SUSPENSION

FENDERS & LICENSE PLATE FRAMES

FOOTRESTS

WHEELS & AXLES

HARDWARE, COVERS & GENERAL



**AIR CLEANER KITS**

- Flows better than stock or competing units, in large part because of its unique internal venturi design of the inner filter
- Optimizes overall performance
- High-flow K&N® Air Filter element ensures the maximum air intake and protection
- Four styles available in black or chrome finishes
- Slim profile keeps the unit away from the rider's leg
- The Cobra system consists of a laser-cut, formed steel cover, separate mounting ring, and all the fasteners, seals, backing plate and mounting hardware for easy installation
- Formed stainless steel mesh insert
- Made in the U.S.A.

CHROME		
PART #	DESCRIPTION	SUG. RETAIL
<b>FOR 08-16 DRESSER, 16-17 FXDLS, 16-17 SOFTTAILS, 14-15 FLSTNSE, 13-14 FXSBSE and 11-12 FLTSE</b>		
1010-1224	Swept	\$209.95
1010-1226	Cross	209.95
1010-1228	Plain	209.95
1010-1230	Spoke	209.95
<b>FOR 99-17 TWIN CAM W/ CV CARB/DELPHI EFI (EXCEPT 08-17 DRESSER, H-D FL TRIKE, 16-17 FXDLS, 16-17 SOFTTAILS, 14-15 FLSTNSE, 13-14 FXSBSE and 11-12 FLTSE)</b>		
1010-1232	Swept	209.95
1010-1234	Cross	209.95
1010-1236	Plain	209.95
1010-1238	Spoke	209.95
<b>FOR 04-17 XL W/ CV CARB/DELPHI EFI</b>		
1010-1240	Swept	209.95
1010-1242	Cross	209.95
1010-1244	Plain	209.95
1010-1246	Spoke	209.95
<b>REPLACEMENT COMPONENT</b>		
1011-3834	Replacement K&N filter	74.95

BLACK		
PART #	DESCRIPTION	SUG. RETAIL
<b>FOR 08-16 DRESSER, 16-17 FXDLS, 16-17 SOFTTAILS, 14-15 FLSTNSE, 13-14 FXSBSE and 11-12 FLTSE</b>		
1010-1225	Swept	\$209.95
1010-1227	Cross	209.95
1010-1229	Plain	209.95
1010-1231	Spoke	209.95
<b>FOR 99-17 TWIN CAM W/ CV CARB/DELPHI EFI (EXCEPT 08-17 DRESSER, H-D FL TRIKE, 16-17 SOFTTAILS, 16-17 FXDLS, 14-15 FLSTNSE, 13-14 FXSBSE and 11-12 FLTSE)</b>		
1010-1233	Swept	209.95
1010-1235	Cross	209.95
1010-1237	Plain	209.95
1010-1239	Spoke	209.95
<b>FOR 04-17 XL W/ CV CARB/DELPHI EFI</b>		
1010-1241	Swept	209.95
1010-1243	Cross	209.95
1010-1245	Plain	209.95
1010-1247	Spoke	209.95
<b>REPLACEMENT COMPONENT</b>		
1011-3834	Replacement K&N filter	74.95

**DISCLAIMER:** NOT LEGAL FOR SALE OR USE IN CALIFORNIA ON ANY POLLUTION CONTROLLED MOTOR VEHICLES. SEE PAGE 399 FOR IMPORTANT EMISSION DEFINITIONS AND REGULATORY COMPLIANCE AND WARRANTY INFORMATION. All part numbers in BLUE are new for 2017.



1010-1042



Contrast Cut



Machine Ops



1010-1041

**CLARITY AIR CLEANERS**

- CNC machined from billet aluminum
- Allows for viewing of the internal moving intake components
- Backing plate promotes smooth airflow into the carb/throttle body
- Includes high-volume K&N air filter
- All mounting hardware included
- Available in chrome, Contrast Cut™, Black Ops™ and Machine Ops™ finishes
- Matching Clarity derby and cam cover available also transmission and rocker box covers
- Made in the U.S.A.

PART #	DESCRIPTION	SUG. RETAIL
<b>FOR 08-16 FLT/H-D TRIKE, 16-17 FXDLS, 16-17 SOFTTAILS, 14-15 FLSTNSE, 13-14 FXSBSE AND 11-12 FLTSE MODELS</b>		
1010-1042	Chrome	\$499.95
1010-1043	Contrast Cut	499.95
1010-1044	Black Ops	499.95
1010-1482	Machine Ops	499.95

PART #	DESCRIPTION	SUG. RETAIL
<b>FOR 01-15 SOFTTAIL MODELS, 04-17 DYNA GLIDE MODELS (EXCEPT FXDLS), 02-07 FLT MODELS W/ DELPHI EFI, 93-06 BIG TWIN MODELS W/ STOCK CV CARB</b>		
1010-1039	Chrome	\$499.95
1010-1040	Contrast Cut	499.95
1010-1041	Black Ops	499.95
1010-1481	Machine Ops	499.95

PART #	DESCRIPTION	SUG. RETAIL
<b>FOR 91-17 XL W/ CV CARB/DELPHI EFI</b>		
1010-1045	Chrome	\$499.95
1010-1046	Contrast Cut	499.95
1010-1047	Black Ops	499.95
1010-1483	Machine Ops	499.95
<b>REPLACEMENT/OPTIONAL COMPONENTS</b>		
1011-3183	Repl. air filter	56.95



Radial Contrast Cut



Radial Black Ops



Split Contrast Cut



Power Machine Ops



Power Contrast Cut



1010-1441

**BLUNT AIR CLEANERS**

- Revolutionary backing plate that promotes smooth airflow into the carb/throttle body
- Hidden crank case breathers
- High volume, best in filtration K & N air filter included
- Smaller filter elements gives more knee clearance
- Available in Machine Ops™, Contrast Cut™ or Black Ops™
- Includes all mounting hardware
- Made in the U.S.A.

PART #	DESCRIPTION	SUG. RETAIL
<b>FOR 08-16 FLT/H-D FL TRIKE, 16-17 FXDLS, 16-17 SOFTTAILS, 14-15 FLSTNSE, 13-14 FXSBSE AND 11-12 FLTSE MODELS</b>		
1010-1494	Radial, Machine Ops	\$421.95
1010-1442	Radial, Contrast Cut	421.95
1010-1451	Radial, Black Ops	421.95
1010-1497	Split, Machine Ops	421.95
1010-1445	Split, Contrast Cut	421.95
1010-1454	Split, Black Ops	421.95
1010-1500	Power, Machine Ops	435.95
1010-1448	Power, Contrast Cut	435.95
1010-1457	Power, Black Ops	435.95

PART #	DESCRIPTION	SUG. RETAIL
<b>FOR 01-15 SOFTTAIL MODELS, 04-17 DYNA GLIDE MODELS (EXCEPT FXDLS), 02-07 FLT MODELS W/ DELPHI EFI AND 93-06 BIG TWIN MODELS W/ STOCK CV CARB</b>		
1010-1493	Radial, Machine Ops	\$421.95
1010-1441	Radial, Contrast Cut	421.95
1010-1450	Radial, Black Ops	421.95
1010-1496	Split, Machine Ops	421.95
1010-1444	Split, Contrast Cut	421.95
1010-1453	Split, Black Ops	421.95
1010-1499	Power, Machine Ops	435.95
1010-1447	Power, Contrast Cut	435.95
1010-1456	Power, Black Ops	435.95

PART #	DESCRIPTION	SUG. RETAIL
<b>FOR 91-17 XL W/ CV CARB/DELPHI EFI</b>		
1010-1495	Radial, Machine Ops	\$421.95
1010-1443	Radial, Contrast Cut	421.95
1010-1452	Radial, Black Ops	421.95
1010-1498	Split, Machine Ops	421.95
1010-1446	Split, Contrast Cut	421.95
1010-1455	Split, Black Ops	421.95
1010-1501	Power, Machine Ops	435.95
1010-1449	Power, Contrast Cut	435.95
1010-1458	Power, Black Ops	435.95
<b>REPLACEMENT/OPTIONAL COMPONENTS</b>		
1011-3184	Repl. air filter	56.95
1011-3237	Optional pre-filter	34.95

**DISCLAIMER:** NOT LEGAL FOR SALE OR USE IN CALIFORNIA ON ANY POLLUTION CONTROLLED MOTOR VEHICLES. SEE PAGE 399 FOR IMPORTANT EMISSION DEFINITIONS AND REGULATORY COMPLIANCE AND WARRANTY INFORMATION.

All part numbers in BLUE are new for 2017.

WINDSHIELDS & FAIRINGS

AUDIO & VIDEO

SADDLEBAGS & LUGGAGE

SEATS & SISSY BARS

EXHAUST

FUEL/AIR SYSTEMS

ENGINE

TRANSMISSION & DRIVELINE

GASKETS & SEALS

ELECTRICAL

LIGHTING

HANDLEBARS, CONTROLS & MIRRORS

CABLES

BRAKES

TANKS & OIL FILTERS

DASHES & GAUGES

FRAMES & SUSPENSION

FENDERS & LICENSE PLATE FRAMES

FOOTRESTS

WHEELS & AXLES

HARDWARE, COVERS & GENERAL

WINDSHIELDS & FAIRINGS

AUDIO & VIDEO

SADDLEBAGS & LUGGAGE

SEATS & SISSY BARS

EXHAUST

FUEL/AIR SYSTEMS

ENGINE

TRANSMISSION & DRIVELINE

GASKETS & SEALS

ELECTRICAL

LIGHTING

HANDLEBARS, CONTROLS & MIRRORS

CABLES

BRAKES

TANKS & OIL FILTERS

DASHES & GAUGES

FRAMES & SUSPENSION

FENDERS & LICENSE PLATE FRAMES

FOOTRESTS

WHEELS & AXLES

HARDWARE, COVERS & GENERAL



Hutch Contrast Cut



Delmar Machine Ops



Delmar Contrast Cut Ops



Raid Machine Ops



Raid Contrast Cut Ops



Morris Black Ops

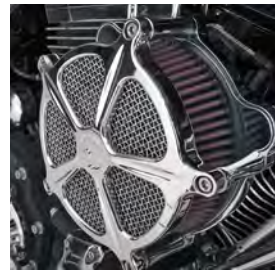

Speed 5 Chrome



Speed 5 Contrast Cut



Speed 7 Chrome



Speed 7 Contrast Cut



Mission Contrast Cut



Ronin Contrast Cut

**VENTURI AIR CLEANERS**

- Exposed filter design that enhances airflow
- Backing plate promotes smooth airflow into carburetor/throttle body
- Built-in internal crank case breathers
- Available in chrome, Platinum Cut, Contrast Cut™, Contrast Cut Ops™, Black Ops™ and Machine Ops™ finishes
- Includes high-volume air filter
- All mounting hardware included
- Made in the U.S.A.

PART #	DESCRIPTION	SUG. RETAIL
<b>FOR 08-16 FLT MODELS/H-D FL TRIKE, 16-17 FXDLS, 16-17 SOFTTAILS, 14-15 FLSTNSE, 13-14 FXSBSE AND 11-12 FLSTSE MODELS</b>		
1010-1802	Hutch, Contrast Cut	\$439.95
1010-1803	Hutch, Black Ops	439.95
1010-1488	Delmar, Machine Ops	439.95
1010-1421	Delmar, Contrast Cut Ops	439.95
1010-1424	Delmar, Chrome	439.95
1010-1491	Raid, Machine Ops	439.95
1010-1427	Raid, Contrast Cut Ops	439.95
1010-1430	Raid, chrome	439.95
1010-1221	Morris, Black Ops	439.95
1010-0373	Speed 5, Chrome	439.95
1010-0374	Speed 5, Contrast Cut	439.95
1010-0422	Speed 7, chrome	439.95
1010-0423	Speed 7, Contrast Cut	439.95
1010-0792	Speed 7, Platinum Cut	439.95
1010-1068	Speed 7, Black Ops	439.95
1010-0718	Mission, Contrast Cut	439.95
1010-0724	Ronin, Contrast Cut	439.95
1010-0804	Domino, Contrast Cut	439.95
1010-0808	Judge, Contrast Cut	439.95
1010-1063	Judge, Black Ops	439.95
1010-0797	Turbo, Contrast Cut	439.95

PART #	DESCRIPTION	SUG. RETAIL
<b>FOR 08-16 FLT MODELS/H-D FL TRIKE, 16-17 FXDLS, 16-17 SOFTTAILS, 14-15 FLSTNSE, 13-14 FXSBSE AND 11-12 FLSTSE MODELS (CONT)</b>		
1010-0897	Boss, Black Ops	\$439.95
1010-0901	Boss, Contrast Cut	439.95
1010-0905	Slam, Black Ops	439.95
1010-0909	Slam, Contrast Cut	439.95
<b>FOR 01-15 SOFTTAIL MODELS, 04-17 DYNA GLIDE MODELS (EXCEPT FXDLS), 02-07 FLT MODELS W/ DELPHI EFI, 93-06 BIG TWIN MODELS W/ STOCK CV CARB</b>		
1010-1804	Hutch, Contrast Cut	439.95
1010-1805	Hutch, Black Ops	439.95
1010-1487	Delmar, Machine Ops	439.95
1010-1420	Delmar, Contrast Cut Ops	439.95
1010-1423	Delmar, Chrome	439.95
1010-1490	Raid, Machine Ops	439.95
1010-1426	Raid, Contrast Cut Ops	439.95
1010-1429	Raid, chrome	439.95
1010-1220	Morris, Black Ops	439.95
1010-0316	Speed 5, chrome	439.95
1010-0317	Speed 5, Contrast Cut	439.95
1010-0420	Speed 7, chrome	439.95
1010-0421	Speed 7, Contrast Cut	439.95
1010-0791	Speed 7, Platinum Cut	439.95

**DISCLAIMER:** NOT LEGAL FOR SALE OR USE IN CALIFORNIA ON ANY POLLUTION CONTROLLED MOTOR VEHICLES. SEE PAGE 399 FOR IMPORTANT EMISSION DEFINITIONS AND REGULATORY COMPLIANCE AND WARRANTY INFORMATION.

All part numbers in **BLUE** are new for 2017.



VENTURI AIR CLEANERS (CONT)



Domino Contrast Cut



Judge Contrast Cut



1010-0803



Judge Black Ops



Turbo Contrast Cut



Boss Black Ops



Boss Contrast Cut



Slam Black Ops



Slam Contrast Cut

1011-2000



1011-2000



WINDSHIELDS & FAIRINGS

AUDIO & VIDEO

SADDLEBAGS & LUGGAGE

SEATS & SISSY BARS

EXHAUST

FUEL/AIR SYSTEMS

ENGINE

TRANSMISSION & DRIVELINE

GASKETS & SEALS

ELECTRICAL

LIGHTING

HANDLEBARS, CONTROLS & MIRRORS

CABLES

BRAKES

TANKS & OIL FILTERS

DASHES & GAUGES

FRAMES & SUSPENSION

FENDERS & LICENSE PLATE FRAMES

FOOTRESTS

WHEELS & AXLES

HARDWARE, COVERS & GENERAL

PART #	DESCRIPTION	SUG. RETAIL
<b>FOR 01-15 SOFTAIL MODELS, 04-17 DYNA GLIDE MODELS (EXCEPT FXDLS), 02-07 FLT MODELS W/ DELPHI EFI, 93-06 BIG TWIN MODELS W/ STOCK CV CARB (CONT)</b>		
1010-1067	Speed 7, Black Ops	\$439.95
1010-0726	Ronin, Contrast Cut	439.95
1010-0803	Domino, Contrast Cut	439.95
1010-0807	Judge, Contrast Cut	439.95
1010-1064	Judge, Black Ops	439.95
1010-0796	Turbo, chrome	439.95
1010-0795	Turbo, Contrast Cut	439.95
1010-0896	Boss, Black Ops	439.95
1010-0900	Boss, Contrast Cut	439.95
1010-0904	Slam, Black Ops	439.95
1010-0908	Slam, Contrast Cut	439.95
<b>FOR 91-17 XL W/ CV CARB/DELPHI EFI</b>		
1010-1806	Hutch, Contrast Cut	439.95
1010-1807	Hutch, Black Ops	439.95
1010-1489	Delmar, Machine Ops	439.95
1010-1422	Delmar, Contrast Cut Ops	439.95
1010-1425	Delmar, Chrome	439.95
1010-1492	Raid, Machine Ops	439.95

PART #	DESCRIPTION	SUG. RETAIL
<b>FOR 91-17 XL W/ CV CARB/DELPHI EFI (CONT)</b>		
1010-1428	Raid, Contrast Cut Ops	\$439.95
1010-1431	Raid, chrome	439.95
1010-0403	Speed 5, Contrast Cut	439.95
1010-0425	Speed 7, Contrast Cut	439.95
1010-0793	Speed 7, Platinum Cut	439.95
1010-1069	Speed 7, Black Ops	439.95
1010-0722	Mission, Contrast Cut	439.95
1010-0728	Ronin, Contrast Cut	439.95
1010-0805	Domino, Contrast Cut	439.95
1010-0809	Judge, Contrast Cut	439.95
1010-1065	Judge, Black Ops	439.95
1010-0800	Turbo, chrome	439.95
1010-0799	Turbo, Contrast Cut	439.95
1010-0902	Boss, Contrast Cut	439.95
1010-0906	Slam, Black Ops	439.95
1010-0910	Slam, Contrast Cut	439.95
<b>REPLACEMENT/OPTIONAL COMPONENTS</b>		
1011-2000	Repl. air filter	57.95
1011-1781	Optional pre-filter style rain sock	29.95

**DISCLAIMER:** NOT LEGAL FOR SALE OR USE IN CALIFORNIA ON ANY POLLUTION CONTROLLED MOTOR VEHICLES. SEE PAGE 399 FOR IMPORTANT EMISSION DEFINITIONS AND REGULATORY COMPLIANCE AND WARRANTY INFORMATION.

All part numbers in BLUE are new for 2017.

WINDSHIELDS & FAIRINGS

AUDIO & VIDEO

SADDLEBAGS & LUGGAGE

SEATS & SISSY BARS

EXHAUST

FUEL/AIR SYSTEMS

ENGINE

TRANSMISSION & DRIVELINE

GASKETS & SEALS

ELECTRICAL

LIGHTING

HANDLEBARS, CONTROLS & MIRRORS

CABLES

BRAKES

TANKS & OIL FILTERS

DASHES & GAUGES

FRAMES & SUSPENSION

FENDERS & LICENSE PLATE FRAMES

FOOTRESTS

WHEELS & AXLES

HARDWARE, COVERS & GENERAL



1010-1195

Contrast Cut



Chrome



Machine Ops



**NOSTALGIA VENTURI AIR CLEANER**

- RSD Nostalgia styling is finally available in our Venturi Air Cleaner
- Featuring trademark RSD hotrod styling with increased ventilation in the face plates, gives the Nostalgia Air Cleaner increased levels of ventilation while keeping it classic
- Design matched to the RSD Nostalgia line of products
- High-volume K&N Air Filter included
- Built-in crank case breathers
- Slotted breather bolts and oil tubes are included with all applications
- Available in Black Ops™, Contrast Cut™ chrome or Machine Ops™
- Made in the U.S.A.

PART #	DESCRIPTION	SUG. RETAIL
<b>FOR 08-16 FLT/H-D FL TRIKE, 16-17 FXDLS, 16-17 SOFTTAILS, 14-15 FLSTNSE, 13-14 FXSBSE AND 11-12 FLTSE MODELS</b>		
1010-1192	Contrast Cut	\$439.95
1010-1196	Black Ops	439.95
1010-1200	Chrome	439.95
1010-1485	Machine Ops	439.95
<b>FOR 01-15 SOFTTAIL, 04-17 DYNA GLIDE (EXCEPT FXDLS), 02-07 FLT W/ DELPHI EFI, 93-06 BIG TWIN W/ STOCK CV CARB</b>		
1010-1191	Contrast Cut	439.95

PART #	DESCRIPTION	SUG. RETAIL
<b>FOR 01-15 SOFTTAIL, 04-17 DYNA GLIDE (EXCEPT FXDLS), 02-07 FLT W/ DELPHI EFI, 93-06 BIG TWIN W/ STOCK CV CARB (CONT)</b>		
1010-1195	Black Ops	\$439.95
1010-1199	Chrome	439.95
1010-1484	Machine Ops	439.95
<b>FOR 91-17 XL W/ CV CARB/DELPHI EFI</b>		
1010-1190	Contrast Cut	439.95
1010-1194	Black Ops	439.95
1010-1198	Chrome	439.95



**AIR CLEANER SCRUB BAG**

- Stretches over complete air cleaner to prevent water from entering engine while washing bike
- Helps to keep water or other debris from entering when bike is parked
- Made from waterproof denier material with an elastic enclosure
- Made in the U.S.A.

NOTE: Cannot be used while engine is running. For washing and storage purposes only.

PART #	DESCRIPTION	SUG. RETAIL
1011-2051	For all RSD Venturi and Turbine air cleaners	\$31.95



**RAIN SOCK**

- Stretches over complete air cleaner for quick and easy roadside installation (no tools required)
- Helps to prevent water from entering your engine when riding in wet conditions
- Compatible with all RSD Venturi and Turbine air cleaner assemblies
- Hydrophobic manufacturing process repels water
- Filters out larger particles of debris down to .005"
- Uniform micron openings allow air in while keeping debris and water out
- Made in the U.S.A.

PART #	DESCRIPTION	SUG. RETAIL
1011-2050	For all RSD Venturi and Turbine air cleaners	\$29.95

**DISCLAIMER:** NOT LEGAL FOR SALE OR USE IN CALIFORNIA ON ANY POLLUTION CONTROLLED MOTOR VEHICLES. SEE PAGE 399 FOR IMPORTANT EMISSION DEFINITIONS AND REGULATORY COMPLIANCE AND WARRANTY INFORMATION.

All part numbers in **BLUE** are new for 2017.



**SLANT CARBON FIBER AIR INTAKE KIT**

- Combines the best in performance and light weight with an ergo-friendly slanted carbon fiber body
- Includes carbon fiber ergo trimmed K&N filter element that is coupled with the newest backing plate shape from Vance & Hines for industry-leading filtration
- The slanted design of this kit provides more knee clearance that is easier on the rider during hard riding
- Features a laser-etched black-anodized outer cover, black-anodized backing plate with internal breathers and mounting hardware and a powder-coated inlet adapter
- Made in the U.S.A.



1010-1248



PART #	DESCRIPTION	SUG. RETAIL
1010-1388	For 08-16 FLT/H-D FL Trike, 16-17 FXDLS, 16-17 Softails, 14-15 FLSTNSE, 13-14 FXSBSE and 11-12 FLSTSE models	\$469.95
1010-1389	For 00-15 FXST/FLST, 99-17 FXD/FXDWG (except FXDLS) and 99-07 FLT/FLHT w/ CV carb/Delphi EFI	469.95

PART #	DESCRIPTION	SUG. RETAIL
1010-1248	For 91-17 XL w/ CV carb/Delphi EFI	\$469.95
<b>REPLACEMENT/OPTIONAL COMPONENTS</b>		
1011-3238	Optional pre-filter	34.95
1011-3160	Replacement air filter	159.95



**TURBINE AIR CLEANERS**

- Exposed filter design offers enhanced airflow
- Backing plate promotes smooth airflow into carb/throttle body
- Built-in internal crankcase breathers
- Available in chrome, black, Contrast Cut™, Black Ops™ and Machine Ops™ finishes
- High-volume K&N air filter
- Laser-engraved center nose cone
- All mounting hardware included
- Made in the U.S.A.



PART #	DESCRIPTION	SUG. RETAIL
<b>FOR 08-16 FLT AND H-D FL TRIKE, 16-17 FXDLS, 16-17 SOFTAILS, 14-15 FLSTNSE, 13-14 FXSBSE AND 11-12 FLSTSE MODELS</b>		
1010-0845	Black	\$439.95
1010-0846	Contrast Cut	439.95
1010-0847	Chrome	439.95
1010-0963	Black Ops	439.95
1010-1479	Machine Ops	439.95
<b>FOR 01-15 SOFTAIL MODELS , 04-17 DYNA GLIDE MODELS (EXCEPT FXDLS), 02-07 FLT MODELS W/ DELPHI EFI, 93-06 BIG TWIN MODELS W/ STOCK CV CARB</b>		
1010-0842	Black	439.95
1010-0843	Contrast Cut	439.95

PART #	DESCRIPTION	SUG. RETAIL
<b>FOR 01-15 SOFTAIL MODELS , 04-17 DYNA GLIDE MODELS (EXCEPT FXDLS), 02-07 FLT MODELS W/ DELPHI EFI, 93-06 BIG TWIN MODELS W/ STOCK CV CARB (CONT)</b>		
1010-0844	Chrome	\$439.95
1010-0962	Black Ops	439.95
1010-1478	Machine Ops	439.95
<b>FOR 91-17 XL W/ CV CARB/DELPHI EFI</b>		
1010-0848	Black	439.95
1010-0849	Contrast Cut	439.95
1010-0850	Chrome	439.95
1010-0964	Black Ops	439.95
1010-1480	Machine Ops	439.95
<b>ACCESSORIES</b>		
1011-2000	Replacement high-volume K&N air filter	57.95

**DISCLAIMER:** NOT LEGAL FOR SALE OR USE IN CALIFORNIA ON ANY POLLUTION CONTROLLED MOTOR VEHICLES. SEE PAGE 399 FOR IMPORTANT EMISSION DEFINITIONS AND REGULATORY COMPLIANCE AND WARRANTY INFORMATION.

All part numbers in BLUE are new for 2017.

WINDSHIELDS & FAIRINGS

AUDIO & VIDEO

SADDLEBAGS & LUGGAGE

SEATS & SISSY BARS

EXHAUST

FUEL/AIR SYSTEMS

ENGINE

TRANSMISSION & DRIVELINE

GASKETS & SEALS

ELECTRICAL

LIGHTING

HANDLEBARS, CONTROLS & MIRRORS

CABLES

BRAKES

TANKS & OIL FILTERS

DASHES & GAUGES

FRAMES & SUSPENSION

FENDERS & LICENSE PLATE FRAMES

FOOTRESTS

WHEELS & AXLES

HARDWARE, COVERS & GENERAL





WINDSHIELDS & FAIRINGS

AUDIO & VIDEO

SADDLEBAGS & LUGGAGE

SEATS & SISSY BARS

EXHAUST

FUEL/AIR SYSTEMS

ENGINE

TRANSMISSION & DRIVELINE

GASKETS & SEALS

ELECTRICAL

LIGHTING

HANDLEBARS, CONTROLS & MIRRORS

CABLES

BRAKES

TANKS & OIL FILTERS

DASHES & GAUGES

FRAMES & SUSPENSION

FENDERS & LICENSE PLATE FRAMES

FOOTRESTS

WHEELS & AXLES

HARDWARE, COVERS & GENERAL



Contrast Cut



Chrome



1010-1324



Black Ops



1011-3187



1011-3189

**MAX HP AIR CLEANER**

- CNC-machined aluminum backing plate
- Internal rubber breather tubes to eliminate oil leakage
- Internal power cone design for smooth, laminar air flow
- Innovative conical design for improved knee clearance
- Contrast Cut™ finish starts with a polished air cleaner that has been black anodized, then recut to open the design
- Black Ops™ finish features gloss black on top of a contrasting textured black finish for outstanding durability and looks
- All mounting hardware and gaskets included
- Made in the U.S.A.

**AIR CLEANERS**

PART #	DESCRIPTION	SUG. RETAIL
<b>FOR 08-16 FLHT/FLHR/FLTR/FLHX/H-D TRIKE, 16-17 FXDLS, 16-17 SOFTTAILS, 14-15 FLSTNSE, 13-14 FXSBSE AND 11-12 FLSTSE</b>		
1010-1328	Contrast Cut	\$449.95
1010-1329	Chrome	449.95
1010-1330	Black Ops	449.95
<b>FOR 01-15 SOFTTAIL MODELS, 04-17 DYNA MODELS (EXCEPT FXDLS), 02-07 FLT MODELS W/ DELPHI EFI, 93-06 BIG TWIN MODELS W/ STOCK CV CARB</b>		
1010-1322	Contrast Cut	449.95
1010-1323	Chrome	449.95
1010-1324	Black Ops	449.95
<b>FOR 91-17 XL W/ CV CARB/DELPHI EFI</b>		
1010-1325	Contrast Cut	449.95
1010-1326	Chrome	449.95
1010-1327	Black Ops	449.95

**OPTIONAL/REPL. COMPONENTS**

PART #	DESCRIPTION	SUG. RETAIL
1011-3187	Rain sock	\$31.95
1011-3189	Repl. air filter	39.95

**REPLACEMENT COMPONENTS FOR SCALLOP/ARRAY AIR CLEANER**

•Made in the U.S.A.

PART #	DESCRIPTION	SUG. RETAIL	PART #	DESCRIPTION	SUG. RETAIL
1011-3188	Rain sock	\$36.95	1011-3190	Repl. air filter	\$39.95



1011-3188



1011-3190

**DISCLAIMER:** NOT LEGAL FOR SALE OR USE IN CALIFORNIA ON ANY POLLUTION CONTROLLED MOTOR VEHICLES. SEE PAGE 399 FOR IMPORTANT EMISSION DEFINITIONS AND REGULATORY COMPLIANCE AND WARRANTY INFORMATION.

All part numbers in **BLUE** are new for 2017.



WINDSHIELDS & FAIRINGS

AUDIO & VIDEO

SADDLEBAGS & LUGGAGE

SEATS & SISSY BARS

EXHAUST

FUEL/AIR SYSTEMS

ENGINE

TRANSMISSION & DRIVELINE

GASKETS & SEALS

ELECTRICAL

LIGHTING

HANDLEBARS, CONTROLS & MIRRORS

CABLES

BRAKES

TANKS & OIL FILTERS

DASHES & GAUGES

FRAMES & SUSPENSION

FENDERS & LICENSE PLATE FRAMES

FOOTRESTS

WHEELS & AXLES

HARDWARE, COVERS & GENERAL

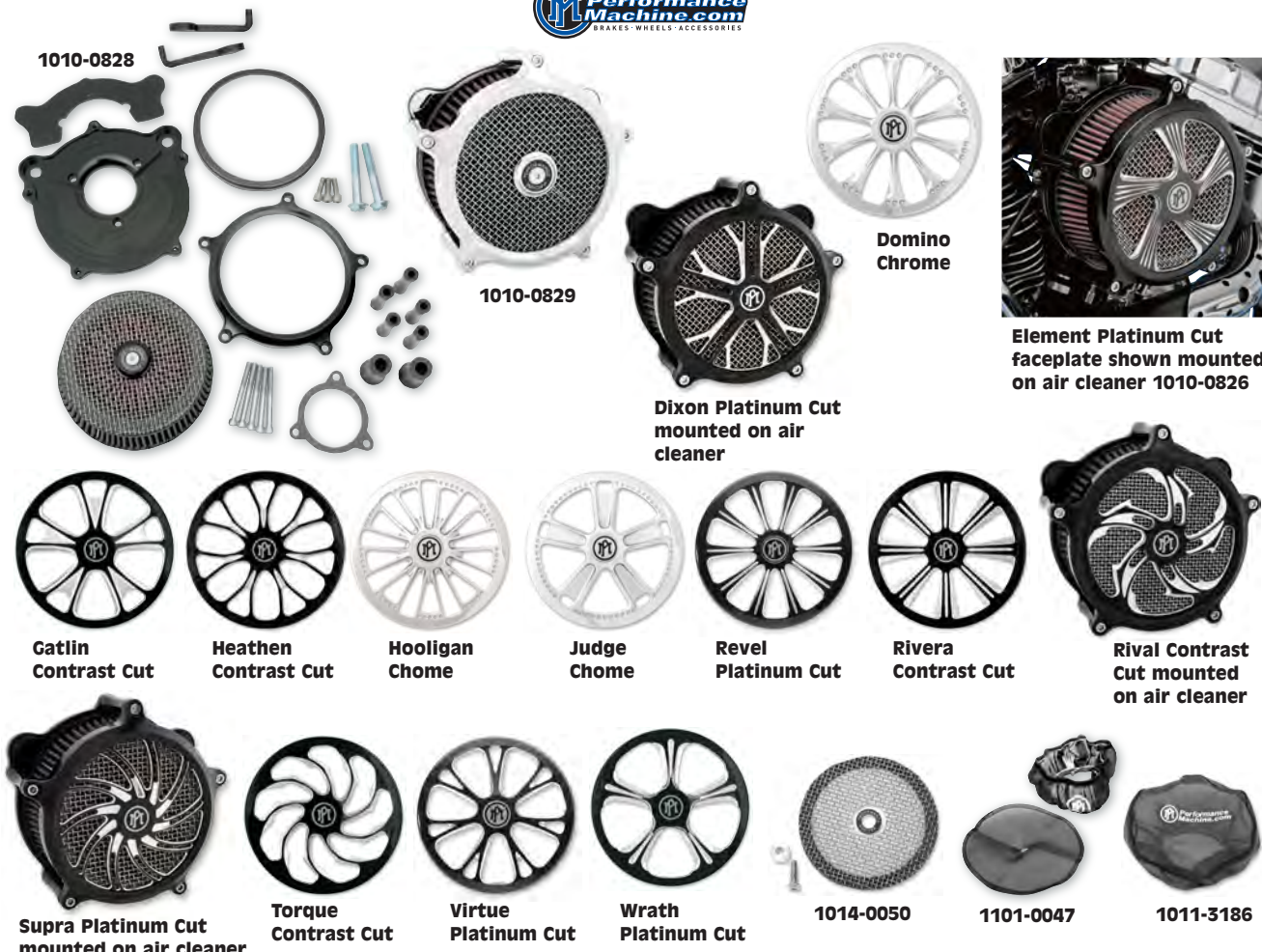

**SUPER GAS AIR CLEANERS AND UNIVERSAL FACEPLATES**

- Versatile design accepts interchangeable faceplates that are designed to match Performance Machine wheels
- Air cleaners include a K&N filter behind a stainless steel wire mesh screen to allow high-volume air flow, resulting in increased horsepower
- Air cleaners and universal faceplates are sold separately and available in chrome, Contrast Cut™ and Platinum Cut finishes
- Contrast Cut™ finish starts with a polished faceplate that has been black anodized, then recut to open up the design
- Platinum Cut uses the same process as the Contrast Cut™, only the recut areas are then hand polished to a brilliant finish
- Screamin' Eagle/Ness upgrade kit adapts a Performance Machine designed faceplate to fit the Screamin' Eagle/Arlen Ness air cleaners
- Screamin' Eagle/Ness upgrade kit includes mesh insert, spacer, hardware, and PM Logo badge
- Made in the U.S.A.

AIR CLEANERS	PART #	DESCRIPTION	SUG. RETAIL
<b>FOR 08-16 TOURING/ H-D FL TRIKE, 16-17 FXDLS, 16-17 SOFTAILS, 14-15 FLSTNSE, 13-14 FXSBSE AND 11-12 FLTSE</b>			
	1010-0828	Black	\$349.95
	1010-0829	Chrome	349.95
<b>FOR 01-17 TWIN CAM W/ DELPHI EFI (EXCEPT 08-17 TOURING, 16-17 FXDLS, 16-17 SOFTAILS, 14-15 FLSTNSE, 13-14 FXSBSE AND 11-12 FLTSE), 93-06 BIG TWIN W/ CV CARB</b>			
	1010-0826	Black	349.95
	1010-0827	Chrome	349.95
<b>FOR 91-17 XL W/ CV CARB/DELPHI EFI</b>			
	1010-0830	Black	349.95
	1010-0831	Chrome	349.95

FACEPLATES/ACCESSORIES								
PART #	DESCRIPTION	SUG. RETAIL	PART #	DESCRIPTION	SUG. RETAIL	PART #	DESCRIPTION	SUG. RETAIL
<b>DIXON</b>			<b>HEATHEN</b>			<b>RIVAL</b>		
1014-0213	Platinum Cut	\$95.95	1014-0058	Contrast Cut	\$85.95	1014-0067	Contrast Cut	\$95.95
1014-0214	Chrome	95.95	1014-0059	Platinum Cut	95.95	1014-0068	Chrome	89.95
<b>DOMINO</b>			<b>HOOLIGAN</b>			<b>SUPRA</b>		
1014-0054	Chrome	89.95	1014-0060	Chrome	95.95	1014-0215	Platinum Cut	95.95
<b>ELEMENT</b>			<b>JUDGE</b>			<b>TORQUE</b>		
1014-0078	Chrome	89.95	1014-0061	Chrome	95.95	1014-0216	Chrome	95.95
1014-0077	Platinum Cut	95.95	<b>JUDGE</b>			<b>TORQUE</b>		
<b>GATLIN</b>			1014-0063	Chrome	89.95	1014-0070	Contrast Cut	89.95
1014-0056	Contrast Cut	85.95	<b>REVEL</b>			1014-0071	Platinum Cut	95.95
1014-0057	Chrome	89.95	1014-0166	Platinum Cut	95.95	1014-0072	Chrome	89.95
<b>1010-0828</b>			<b>RIVERA</b>			<b>VIRTUE</b>		
<b>1010-0829</b>			1014-0064	Contrast Cut	95.95	1014-0167	Platinum Cut	95.95

**Element Platinum Cut faceplate shown mounted on air cleaner 1010-0826**

**Dixon Platinum Cut mounted on air cleaner**

**Rival Contrast Cut mounted on air cleaner**

**Supra Platinum Cut mounted on air cleaner**

**Torque Contrast Cut**

**Virtue Platinum Cut**

**Wrath Platinum Cut**

**1014-0050**

**1101-0047**

**1011-3186**

**DISCLAIMER:** NOT LEGAL FOR SALE OR USE IN CALIFORNIA ON ANY POLLUTION CONTROLLED MOTOR VEHICLES. SEE PAGE 399 FOR IMPORTANT EMISSION DEFINITIONS AND REGULATORY COMPLIANCE AND WARRANTY INFORMATION.

All part numbers in BLUE are new for 2017.

WINDSHIELDS & FAIRINGS

AUDIO & VIDEO

SADDLEBAGS & LUGGAGE

SEATS & SISSY BARS

EXHAUST

FUEL/AIR SYSTEMS

ENGINE

TRANSMISSION & DRIVELINE

GASKETS & SEALS

ELECTRICAL

LIGHTING

HANDLEBARS, CONTROLS & MIRRORS

CABLES

BRAKES

TANKS & OIL FILTERS

DASHES & GAUGES

FRAMES & SUSPENSION

FENDERS & LICENSE PLATE FRAMES

FOOTRESTS

WHEELS & AXLES

HARDWARE, COVERS & GENERAL



Black Ops



Contrast Cut

**DRIVE AIR CLEANERS**

- Design boasts an industrial polygon shape that follows the line of the V-Twin
- Detail accents give an organic look
- High-volume, high-flow K&N® air filter to boost power
- Internal crankcase venting system
- CNC-machined cover available in multiple finishes
- Contrast Cut™ finish starts with a polished face plate that has been black-anodized, then re-cut to open up the design
- Black Ops™ finish features a gloss black powdercoat on top of a contrasting textured black finish for outstanding durability and great looks
- Show-chrome finish also available
- Mounting hardware included
- Made in the U.S.A.

PART #	DESCRIPTION	SUG. RETAIL
<b>FOR 08-16 FLHT/FLHR/FLTR/FLHX/H-D FL TRIKE, 16-17 FXDLS, 16-17 SOFTTAILS, 14-15 FLSTNSE, 13-14 FXSBSE AND 11-12 FLTSE</b>		
1010-1669	Contrast Cut	\$419.95
1010-1671	Chrome	419.95
1010-1672	Black Ops	419.95
<b>FOR 01-17 TWIN CAM W/ DELPHI EFI (EXCEPT 08-17 FLHT/FLHR/FLTR/FLHX/H-D FL TRIKES, 16-17 FXDLS, 16-17 SOFTTAILS, 14-15 FLSTNSE, 13-14 FXSBSE AND 11-12 FLTSE); 93-06 BIG TWIN W/ CV CARBURETOR</b>		
1010-1665	Contrast Cut	419.95

PART #	DESCRIPTION	SUG. RETAIL
<b>FOR 01-17 TWIN CAM W/ DELPHI EFI (EXCEPT 08-17 FLHT/FLHR/FLTR/FLHX/H-D FL TRIKES, 16-17 FXDLS, 16-17 SOFTTAILS, 14-15 FLSTNSE, 13-14 FXSBSE AND 11-12 FLTSE); 93-06 BIG TWIN W/ CV CARBURETOR (CONT)</b>		
1010-1667	Chrome	\$419.95
1010-1668	Black Ops	419.95
<b>FOR 91-17 XL W/ DELPHI EFI OR CV CARBURETOR</b>		
1010-1673	Contrast Cut	419.95
1010-1675	Chrome	419.95
1010-1676	Black Ops	419.95



1010-1586



1010-1587

**JET AIR CLEANERS**

- Low-profile and lightweight air cleaners are CNC-machined from billet aluminum
- Innovative and versatile design allows unit to be mounted in the vertical or horizontal position
- Compact design for improved knee clearance
- Features PM's proven internal crankcase venting system
- Feature a high-flow reusable air filter
- Available in Contrast Cut™, chrome and Black Ops™ finishes
- Contrast Cut™ finish starts with a polished air cleaner that has been black anodized, then recut to open the design
- Black Ops™ finish features gloss black on top of a contrasting textured black finish for outstanding durability and looks
- Made in the U.S.A.

PART #	DESCRIPTION	SUG. RETAIL
<b>FOR 08-16 FLHT/FLHR/FLHX/FLTR, 16-17 FXDLS, 16-17 SOFTTAILS, 14-15 FLSTNSE, 13-14 FXSBSE AND 11-12 FLTSE</b>		
1010-1588	Contrast Cut	\$499.95
1010-1589	Chrome	499.95
1010-1590	Black Ops	499.95

PART #	DESCRIPTION	SUG. RETAIL
<b>FOR 01-17 TWIN CAM W/ DELPHI EFI (EXCEPT 08-17 TOURING, 16-17 FXDLS, 16-17 SOFTTAILS, 14-15 FLSTNSE, 13-14 FXSBSE AND 11-12 FLTSE); 93-06 TWIN CAM W/ CV CARB</b>		
1010-1585	Contrast Cut	\$499.95
1010-1586	Chrome	499.95
1010-1587	Black Ops	499.95

PART #	DESCRIPTION	SUG. RETAIL
<b>FOR 91-17 XL W/ CV CARB/DEPHI EFI</b>		
1010-1591	Contrast Cut	\$499.95
1010-1592	Chrome	499.95
1010-1593	Black Ops	499.95
<b>OPTIONAL/REPL. COMPONENTS</b>		
1011-3593	Rain sock	29.95

**DISCLAIMER:** NOT LEGAL FOR SALE OR USE IN CALIFORNIA ON ANY POLLUTION CONTROLLED MOTOR VEHICLES. SEE PAGE 399 FOR IMPORTANT EMISSION DEFINITIONS AND REGULATORY COMPLIANCE AND WARRANTY INFORMATION.

All part numbers in **BLUE** are new for 2017.



WINDSHIELDS & FAIRINGS

AUDIO & VIDEO

SADDLEBAGS & LUGGAGE

SEATS & SISSY BARS

EXHAUST

FUEL/AIR SYSTEMS

ENGINE

TRANSMISSION & DRIVELINE

GASKETS & SEALS

ELECTRICAL

LIGHTING

HANDLEBARS, CONTROLS & MIRRORS

CABLES

BRAKES

TANKS & OIL FILTERS

DASHES & GAUGES

FRAMES & SUSPENSION

FENDERS & LICENSE PLATE FRAMES

FOOTRESTS

WHEELS & AXLES

HARDWARE, COVERS & GENERAL

**NAKED VO2 AIR INTAKES**

- For those wanting to keep the stock look, but not necessarily the stock performance
- Vance & Hines now offers its VO2 Air Intake as a high-flow replacement kit
- PART #s 1010-2081 and 1010-0738 use stock air cleaner cover; PART #s 1010-0739, 1010-0865 and 1010-0866 must use air cleaner covers PART #s 1010-0867, 1010-0868, 1010-1051, 1010-1052
- Designed and manufactured entirely in-house, the VO2 Naked includes a high-flow washable filter element, larger inlet backing plate and billet venturi to get more air in rider's motor for more power
- Made in the U.S.A.

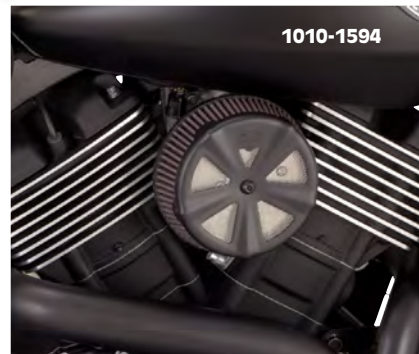

PART #	DESCRIPTION	SUG. RETAIL
<b>1010-2081</b>	For 17 FLHT/FLHR/FLHX/FLTRX/H-D FL Trike models	<b>\$179.99</b>
<b>1010-1611</b>	For 14-16 FLHT/FLHR/FLHX/FLTR/H-D FL Trike and 16-17 Softails (except FLSS/FLSTFBS) models	<b>179.99</b>
<b>1010-0739<sup>1</sup></b>	For 08-13 FLHT/FLHR/FLHX/LTR and H-D FL Trike models	<b>149.99</b>
<b>1010-0738</b>	For 01-17 Twin Cam w/ Delphi EFI, 99-06 Twin Cam w/CV carb (except 08-17 Dressers, Dyna, X-Bones, 16-17 Softails)	<b>149.99</b>
<b>1010-0865</b>	For 08-17 FXD/FXDWG models (except FXDLS)	<b>149.99</b>
<b>1010-0866</b>	For 91-17 XL models	<b>149.99</b>
<b>1010-1594<sup>1</sup></b>	For 15-17 XG 500/750	<b>129.99</b>

<sup>1</sup> Require air cleaner cover PART #s 1010-0867, 1010-0868, 1010-1051 or 1010-1052.



**GRENADE AIR INTAKES**

- Improves engine performance with a touch of class and style, resonant with the stepped design of the HI-Output Grenades exhaust system
- CNC machined billet cover with riveted badge
- Washable high-flow filter element
- Larger inlet backing plate
- CNC machined billet venturi
- Made in the U.S.A.

PART #	DESCRIPTION	SUG. RETAIL
<b>CHROME</b>		
<b>1010-1726</b>	For 08-16 FLHT/FLHR/FLHX/FLTR/H-D FL Trike, 16-17 FXDLS, 16-17 Softails, 14-15 FLSTNSE, 13-14 FXSBSE and 11-12 FLSTSE models	<b>\$349.99</b>
<b>1010-1729</b>	For 01-17 Twin Cam w/ Delphi EFI, 99-06 Twin Cam w/CV carb (except 08-17 Dressers, X-Bones, 16-17 FXDLS, 16-17 Softails, 14-15 FLSTNSE, 13-14 FXSBSE and 11-12 FLSTSE)	<b>349.99</b>
<b>1010-1732</b>	For 91-17 XL models	<b>349.99</b>
<b>BLACK</b>		
<b>1010-1727</b>	For 08-16 FLHT/FLHR/FLHX/FLTR/H-D FL Trike, 16-17 FXDLS, 16-17 Softails, 14-15 FLSTNSE, 13-14 FXSBSE and 11-12 FLSTSE models	<b>349.99</b>
<b>1010-1730</b>	For 01-17 Twin Cam w/ Delphi EFI, 99-06 Twin Cam w/CV carb (except 08-17 Dressers, X-Bones, 16-17 FXDLS, 16-17 Softails, 14-15 FLSTNSE, 13-14 FXSBSE and 11-12 FLSTSE)	<b>349.99</b>
<b>1010-1733</b>	For 91-17 XL models	<b>349.99</b>
<b>MACHINED BLACK</b>		
<b>1010-1728</b>	For 08-16 FLHT/FLHR/FLHX/FLTR/H-D FL Trike, 16-17 FXDLS, 16-17 Softails, 14-15 FLSTNSE, 13-14 FXSBSE and 11-12 FLSTSE models	<b>349.99</b>
<b>1010-1731</b>	For 01-17 Twin Cam w/ Delphi EFI, 99-06 Twin Cam w/CV carb (except 08-17 Dressers, X-Bones, 16-17 FXDLS, 16-17 Softails, 14-15 FLSTNSE, 13-14 FXSBSE and 11-12 FLSTSE)	<b>349.99</b>
<b>1010-1734</b>	For 91-17 XL models	<b>349.99</b>

**DISCLAIMER:** NOT LEGAL FOR SALE OR USE IN CALIFORNIA ON ANY POLLUTION CONTROLLED MOTOR VEHICLES. SEE PAGE 399 FOR IMPORTANT EMISSION DEFINITIONS AND REGULATORY COMPLIANCE AND WARRANTY INFORMATION.

All part numbers in **BLUE** are new for 2017.



WINDSHIELDS & FAIRINGS

AUDIO & VIDEO

SADDLEBAGS & LUGGAGE

SEATS & SISSY BARS

EXHAUST

FUEL/AIR SYSTEMS

ENGINE

TRANSMISSION & DRIVELINE

GASKETS & SEALS

ELECTRICAL

LIGHTING

HANDLEBARS, CONTROLS & MIRRORS

CABLES

BRAKES

TANKS & OIL FILTERS

DASHES & GAUGES

FRAMES & SUSPENSION

FENDERS & LICENSE PLATE FRAMES

FOOTRESTS

WHEELS & AXLES

HARDWARE, COVERS & GENERAL



1010-0475



1010-0479



1022-0052



1010-0407



**AIR INTAKES**

- It's all about how much air a motor can take in
- Here are systems that work better and look better than any other systems on the market
- An all-aluminum venturi in both designs helps shape the air for better flow
- Hand-formed steel covers for a distinctive look that is a perfect match for any Vance & Hines exhaust system
- Exhaust, fuel and now air is the complete package
- Each include a high-flow washable and reusable air filter
- Made in the U.S.A.

**DUKE COVER**

PART #	DESCRIPTION	SUG. RETAIL
<b>CHROME</b>		
1010-0477	For 08-16 FLHT/FLHR/FLHX/FLTR/H-D FL Trikes, 16-17 FXDLS, 16-17 Softails, 14-15 FLSTNSE, 13-14 FXSBSE and 11-12 FLSTSE	\$279.99
1010-0475	For 01-17 Twin Cam w/ Delphi EFI (except 08-17 FLHT/FLHR/FLHX/FLTR/H-D FL Trikes, 16-17 FXDLS, 16-17 Softails, 14-15 FLSTNSE, 13-14 FXSBSE and 11-12 FLSTSE), 99-06 Twin Cam w/ CV carb	279.99
1010-0476	For 04-17 XL	279.99
<b>BLACK</b>		
1010-0478	For 01-17 Twin Cam w/ Delphi EFI (except 08-17 FLHT/FLHR/FLHX/FLTR, 16-17 FXDLS, 16-17 Softails, 14-15 FLSTNSE, 13-14 FXSBSE and 11-12 FLSTSE), 99-06 Twin Cam w/ CV carb	279.99
1010-0479	For 04-17 XL	279.99

**DRAK COVER**

PART #	DESCRIPTION	SUG. RETAIL
<b>CHROME</b>		
1022-0055	For 08-16 FLHT/FLHR/FLHX/FLTR/H-D FL Trikes, 16-17 FXDLS, 16-17 Softails, 14-15 FLSTNSE, 13-14 FXSBSE and 11-12 FLSTSE	\$259.99
1022-0052	For 01-17 Twin Cam w/ Delphi EFI (except 08-17 FLHT/FLHR/FLHX/FLTR/H-D FL Trikes, 16-17 FXDLS, 16-17 Softails, 14-15 FLSTNSE, 13-14 FXSBSE and 11-12 FLSTSE), 99-06 Twin Cam w/ CV carb	259.99
<b>BLACK</b>		
1010-0407	For 08-16 FLHT/FLHR/FLHX/FLTR/H-D FL Trikes, 16-17 FXDLS, 16-17 Softails, 14-15 FLSTNSE, 13-14 FXSBSE and 11-12 FLSTSE	259.99
1010-0406	For 01-17 Twin Cam w/ Delphi EFI (except 08-17 FLHT/FLHR/FLHX/FLTR/H-D FL Trikes, 16-17 FXDLS, 16-17 Softails, 14-15 FLSTNSE, 13-14 FXSBSE and 11-12 FLSTSE), 99-06 Twin Cam w/ CV carb	259.99

PART #	DESCRIPTION	SUG. RETAIL
<b>REPLACEMENT AIR FILTER</b>		
1011-2939	Repl. filter for VO2 air cleaners	\$69.99

**DISCLAIMER:** NOT LEGAL FOR SALE OR USE IN CALIFORNIA ON ANY POLLUTION CONTROLLED MOTOR VEHICLES. SEE PAGE 399 FOR IMPORTANT EMISSION DEFINITIONS AND REGULATORY COMPLIANCE AND WARRANTY INFORMATION.

All part numbers in **BLUE** are new for 2017.

**KURYAKYN**

1010-0213



1010-1544



**PRO R HYPERCHARGER™**

- The best-flowing Hypercharger™ ever produced
- Careful redesign of all interior shapes increases airflow
- Additional air scoop on outer cover directs air onto the high-flow, washable and reusable air filter
- Unrestricted air under high-load riding situations from huge front butterflies are vacuum operated
- Include all necessary mounting hardware and crankcase breather kit
- PART #1010-0217 is an assembly (CV bolt pattern) that can be used with adapters, brackets or mounting kits to cover applications that do not have a specific kit

PART #	DESCRIPTION	SUG. RETAIL	PART #	DESCRIPTION	SUG. RETAIL
1010-1004	For 08-16 FLHT/FLHR/FLTR/FLHX, H-D FL Trikes, 16-17 FXDLS, 16-17 Softails, 14-15 FLSTNSE, 13-14 FXSBSE and 11-12 FLSTSE	\$329.99	1010-1058	For 07-17 XL	\$299.99
1010-0215	For 06-17 w/ Delphi EFI (except 08-17 FLHT/FLHR/FLTR/FLHX, H-D FL Trikes, 16-17 FXDLS, 16-17 Softails, 14-15 FLSTNSE, 13-14 FXSBSE and 11-12 FLSTSE), 99-06 Twin Cam w/ CV carb	329.99	1011-1079	Repl. K&N air filter (ea.)	59.99
1010-0216	For 01-05 Twin Cam w/ Delphi EFI	329.99	1011-3206	Repl. cage/foam filter assembly	16.99
1010-0214	For 93-99 Evolution Big Twin w/ CV carb	299.99	1010-1547	Repl. butterfly shaft kit w/ screws, washers, bearings and springs (kit)	16.99
1010-0213	For 91-06 XL models w/ CV carb	299.99	1010-1544	Repl. chrome butterflies	14.99
			1011-3599	Opt. pre-filter (ea.)	34.99

1010-1003



DS-288938



DS-288939



1010-1544



**PRO SERIES HYPERCHARGER™**

- Features a 50% larger air filter for massive airflow
- Internal shape has been modified to allow increased airflow and velocity
- One-piece construction, ball-milled, "speed lines" symmetrical butterflies and new "Pro" embossed bearing cups
- Edges of Pro Series Hypercharger™ are radiused for a more streamlined appearance
- An upgrade kit is available for new-style (replaceable bearing cup) Hyperchargers and includes a new "Pro" outer case half, bearing cups, butterflies, large K&N air filter and necessary hardware

PART #	DESCRIPTION	SUG. RETAIL
1010-1003	W/ chrome butterflies for 08-16 FLHT/FLHR/FLTR/FLHX and H-D FL Trikes, 16-17 FXDLS, 16-17 Softail, 11-12 FLSTSE, 13-14 FXSBSE, 14-15 FLSTNSE	\$289.99
DS-288938	W/ chrome butterflies for 01-17 Delphi EFI (except 16-17 FXDLS, 16-17 Softail, 08-17 FLHT/FLHR/FLTR/FLHX and H-D FL Trikes), 99-06 Twin Cam w/ CV carb	289.99
1010-0149	W/ chrome butterflies for 99-01 FLT (Dresser and Road King) w/ Magnetti-Marelli EFI	299.99
DS-288936	W/ chrome butterflies for 91-06 XL w/ CV carb	289.99
1010-1057	W/ chrome butterflies for 07-17 XL	289.99
DS-288939	Upgrade kit	139.99
1011-3206	Repl. cage/foam filter assembly	16.99
1010-1544	Chrome butterflies (pr.)	14.99
1010-1548	Case screws (set of 3)	6.99

**DISCLAIMER:** NOT LEGAL FOR SALE OR USE IN CALIFORNIA ON ANY POLLUTION CONTROLLED MOTOR VEHICLES. SEE PAGE 399 FOR IMPORTANT EMISSION DEFINITIONS AND REGULATORY COMPLIANCE AND WARRANTY INFORMATION.

All part numbers in BLUE are new for 2017.

WINDSHIELDS & FAIRINGS

AUDIO & VIDEO

SADDLEBAGS & LUGGAGE

SEATS & SISSY BARS

EXHAUST

FUEL/AIR SYSTEMS

ENGINE

TRANSMISSION & DRIVELINE

GASKETS & SEALS

ELECTRICAL

LIGHTING

HANDLEBARS, CONTROLS & MIRRORS

CABLES

BRAKES

TANKS & OIL FILTERS

DASHES & GAUGES

FRAMES & SUSPENSION

FENDERS & LICENSE PLATE FRAMES

FOOTRESTS

WHEELS & AXLES

HARDWARE, COVERS & GENERAL

**KURYAKYN**

WINDSHIELDS & FAIRINGS

AUDIO & VIDEO

SADDLEBAGS & LUGGAGE

SEATS & SISSY BARS

EXHAUST

FUEL/AIR SYSTEMS

ENGINE

TRANSMISSION & DRIVELINE

GASKETS & SEALS

ELECTRICAL

LIGHTING

HANDLEBARS, CONTROLS & MIRRORS

CABLES

BRAKES

TANKS & OIL FILTERS

DASHES & GAUGES

FRAMES & SUSPENSION

FENDERS & LICENSE PLATE FRAMES

FOOTRESTS

WHEELS & AXLES

HARDWARE, COVERS & GENERAL



**STINGER TRAP DOOR FOR HYPERCHARGER™**

- If you have a need for more performance, look no further
- Stinger trap door maximizes airflow into the carburetor or throttle body through a high-flow filter element
- Highly cost-effective way to boost airflow to any standard Hypercharger™
- Easy four-bolt replacement for standard trap door
- Chrome finish

PART #	DESCRIPTION	SUG. RETAIL
<b>1010-0145</b>	Stinger trap door (ea.)	<b>\$59.99</b>



**INFINITY STREAMLINER FOR HYPERCHARGER™**

- Transform this cover from smooth chrome to a stunning LED vortex of lights with just a flick of the switch
- Seven-color LED operates in three modes: single color steady illumination; single color flashing illumination with rheostat-adjustable rate; and paint mode – continuously fading in and out of seven colors (red, lime, ice blue, sky blue, dark blue, purple and green) with rheostat-adjustable rate of color change
- Installs on any standard Hypercharger air cleaner (except Pro R, Pro Series Hypercharger)
- Not for use with Stinger trap door

PART #	DESCRIPTION	SUG. RETAIL
<b>1014-0130</b>	Streamliner Infinity cover for Hypercharger™	<b>\$199.99</b>



**CLEAR TRAP DOOR FOR HYPERCHARGER®**

- Direct replacement for the trap door on Kuryakyn's standard and Blood Groove Hyperchargers®
- Gives you an inside look at the inner workings of the air cleaner and throttle body
- Trim ring is cast aluminum construction
- Clear window is made from durable, shatterproof polycarbonate
- Gasket included

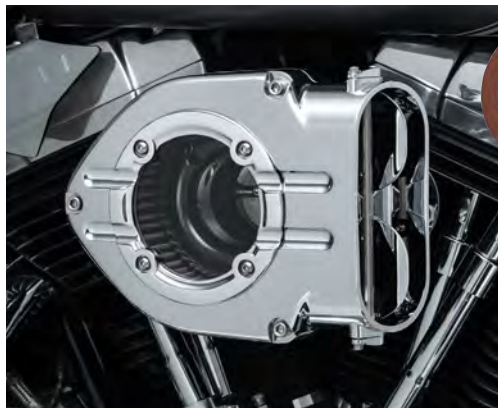

PART #	DESCRIPTION	SUG. RETAIL	PART #	DESCRIPTION	SUG. RETAIL
<b>1014-0242</b>	Chrome	<b>\$39.99</b>	<b>1014-0243</b>	Gloss black	<b>\$39.99</b>



**LIGHTED VELOCITY RING FOR AIR CLEANERS**

- Add LED style to your intake system
  - Seven-color lighted velocity ring insert features 15 super-bright LEDs
  - Can choose between solid color illumination (red, ice blue, sky blue, dark blue, purple or green), single-color flash color illumination, and paint mode – continuously fade in and out of the seven colors with rheostat-adjustable rate of color change
  - Mounts beneath the air filter element
  - Requires a standard Kuryakyn Infinity Light controller (PART #2050-0176) or Bluetooth® Infinity Lights controller (PART #2050-0266); sold separately
- NOTE:** Requires drilling into air cleaner backing plate to route wiring for installation.



PART #	DESCRIPTION	SUG. RETAIL
<b>2040-1895</b>	For Kuryakyn Hypercharger®, Mach 2, Mach 2 Co-Ax, Crusher Maverick and Bahn air cleaners	<b>\$99.99</b>

**DISCLAIMER:** NOT LEGAL FOR SALE OR USE IN CALIFORNIA ON ANY POLLUTION CONTROLLED MOTOR VEHICLES. SEE PAGE 399 FOR IMPORTANT EMISSION DEFINITIONS AND REGULATORY COMPLIANCE AND WARRANTY INFORMATION.

All part numbers in **BLUE** are new for 2017.



**HYPERCHARGER™ AIR CLEANERS**

- These air cleaners look great and work even better
- Outstanding performance on stock or mildly modified engines up to 90 horsepower
- Available with a standard (smooth) trap door or our Blood Groove design
- Chrome-plated or gloss black body and trapdoor with either chrome or black butterflies
- Provide excellent legroom for comfort while riding
- Include Kuryakyn's breather where applicable



PART #	DESCRIPTION	SUG. RETAIL
<b>CHROME HYPERCHARGER WITH SMOOTH TRAP DOOR</b>		
1010-1566	W/ chrome butterflies for 08-16 FLHR/FLHT/FLHX/FLTR/H-D FL Trikes, 16-17 Softail, 16-17 FXDLS, 11-12 FLSTSE, 13-14 FXSBSE, 14-15 FLSTNSE	\$259.99
1010-0156	W/ chrome butterflies for 06-17 Twin Cam w/ Delphi EFI (except 16-17 Softail, 16-17 FXDLS, 08-17 FLHR/FLHT/FLHX/FLTR and H-D FL Trike), 99-06 Twin Cam w/ CV carb	259.99
1010-0157	W/ chrome butterflies for 01-05 Twin Cam w/ Delphi EFI	289.99
1010-1649	W/ chrome butterflies for 99-01 Twin Cam with Magneti Marelli EFI	269.99
1010-0136	W/ chrome butterflies for 93-99 EVO Big Twin w/ S&S E or G series carb	289.99
1010-1648	W/ chrome butterflies for 93-99 Evo Big Twin Models with Mikuni HSR 42 or 45 Carb	269.99
1010-0140	W/ chrome butterflies for 93-99 EVO Big Twin w/ stock carb	239.99
1010-0143	W/ chrome butterflies for 90-91 Big Twin w/ stock carb	229.99
1010-0142	W/ chrome butterflies for 84-89 Big Twin w/ stock or S&S B series carb	229.99
1010-1406	W/ chrome butterflies for 07-17 XL w/ stock carb w/ Delphi EFI	239.99
1010-0137	W/ chrome butterflies for 91-06 XL w/ stock carb and H-D breather	229.99
1010-0141	W/ chrome butterflies for 91-06 XL w/ stock carb	239.99
<b>CHROME HYPERCHARGER WITH BLOOD GROOVE TRAP DOOR</b>		
DS-288845	W/ chrome butterflies for 99-01 FLTR/FLHT/FLHR w/ Magneti-Marelli EFI	289.99
DS-288844	W/ chrome butterflies for 06-17 Twin Cam w/ Delphi EFI (except 16-17 Softail, 16-17 FXDLS, 08-17 FLHR/FLHT/FLHX/FLTR and H-D FL Trike), 99-06 Twin Cam w/ CV carb	259.99
1010-1002	W/ chrome butterflies for 08-16 FLHR/FLHT/FLHX/FLTR/H-D FL Trikes, 16-17 Softail, 16-17 FXDLS, 11-12 FLSTSE, 13-14 FXSBSE, 14-15 FLSTNSE	259.99
DS-288821	W/ chrome butterflies for 93-99 EVO Big Twin w/ stock carb	269.99
DS-288940	W/ chrome butterflies for 93-99 EVO Big Twin w/ S&S E & G carb	299.99
1010-1568	W/ chrome butterflies for 07-17 XL w/ Delphi EFI	269.99
DS-288823	W/ chrome butterflies for 91-06 XL models w/ stock carb	269.99
1010-1577	W/ chrome butterflies for custom applications (must use adapters, brackets or custom mount kit, available separately)	219.99
<b>GLOSS BLACK HYPERCHARGER WITH BLOOD GROOVE TRAP DOOR</b>		
1010-1571	W/ black butterflies for 08-16 FLHR/FLHT/FLHX/FLTR/H-D FL Trikes, 16-17 Softail, 16-17 FXDLS, 11-12 FLSTSE, 13-14 FXSBSE, 14-15 FLSTNSE	289.99
1010-1582	W/ black butterflies for 01-05 Twin Cam w/ Delphi EFI	309.99
1010-1579	W/ black butterflies for 06-17 Twin Cam w/ Delphi EFI (except 16-17 Softail, 16-17 FXDLS, 08-17 FLHR/FLHT/FLHX/FLTR and H-D FL Trike), 99-06 Twin Cam w/ CV carb	289.99
1010-1580	W/ black butterflies for 93-99 EVO Big Twin w/ stock carb	289.99
1010-1569	W/ black butterflies for 07-17 XL w/ Delphi EFI	289.99
<b>WRINKLE BLACK HYPERCHARGER WITH BLOOD GROOVE TRAP DOOR</b>		
1010-1573	W/ chrome butterflies for 08-16 FLHR/FLHT/FLHX/FLTR/H-D FL Trikes, 16-17 Softail, 16-17 FXDLS, 11-12 FLSTSE, 13-14 FXSBSE, 14-15 FLSTNSE	289.99
1010-1575	W/ chrome butterflies for 06-17 Twin Cam w/ Delphi EFI (except 16-17 Softail, 16-17 FXDLS, 08-17 FLHR/FLHT/FLHX/FLTR and H-D FL Trike), 99-06 Twin Cam w/ CV carb	289.99
1010-1576	W/ chrome butterflies for 93-99 Evolution Big Twin w/ stock carb	279.99
<b>HYPERCHARGER ACCESSORIES</b>		
1013-0096	Throttle body support bracket for 08-16 FLHR/FLHT/FLHX/FLTR/H-D FL Trikes, 16-17 Softail, 16-17 FXDLS, 11-12 FLSTSE, 13-14 FXSBSE, 14-15 FLSTNSE	29.99
1013-0098	Carburetor support bracket for 93-99 Evolution Big Twin with stock CV, Mikuni or Screamin' Eagle carburetor	34.99
1013-0108	Carburetor support bracket for 88-06 XL with CV, Mikuni, Rev Tech or Screamin' Eagle carburetors	36.99
1013-0101	Bolt 1" mount	8.99

HYPERCHARGER™ AIR CLEANERS continued on next page

**DISCLAIMER:** NOT LEGAL FOR SALE OR USE IN CALIFORNIA ON ANY POLLUTION CONTROLLED MOTOR VEHICLES. SEE PAGE 399 FOR IMPORTANT EMISSION DEFINITIONS AND REGULATORY COMPLIANCE AND WARRANTY INFORMATION.

All part numbers in BLUE are new for 2017.

WINDSHIELDS & FAIRINGS

AUDIO & VIDEO

SADDLEBAGS & LUGGAGE

SEATS & SISSY BARS

EXHAUST

FUEL/AIR SYSTEMS

ENGINE

TRANSMISSION & DRIVELINE

GASKETS & SEALS

ELECTRICAL

LIGHTING

HANDLEBARS, CONTROLS & MIRRORS

CABLES

BRAKES

TANKS & OIL FILTERS

DASHES & GAUGES

FRAMES & SUSPENSION

FENDERS & LICENSE PLATE FRAMES

FOOTRESTS

WHEELS & AXLES

HARDWARE, COVERS & GENERAL



**KURYAKYN**  **HYPERCHARGER™ AIR CLEANERS (CONT)**



**1010-1006**



**1012-0170**

PART #	DESCRIPTION	SUG. RETAIL
<b>HYPERCHARGER ACCESSORIES (CONT)</b>		
<b>1013-0107</b>	Mount kit for 06-17 Twin Cam with Delphi EFI (except 08-17 Touring/Trike, 16-17 Softail, 16-17 FXDLS, 11-12 FLSTSE, 13-14 FXSBSE and 14-15 FLSTNSE)	<b>\$69.99</b>
<b>1013-0106</b>	Mount kit for 99-06 Twin Cam with CV Carburetor	<b>69.99</b>
<b>DS-288827</b>	Adapter to mount Hypercharger on S&S E and G carburetors for 93-99 Big Twin and 91-06 XL models (requires PART #DS-288826 adjustable enricher and 1/2"-13 x 1 1/2" breather bolts)	<b>49.99</b>
<b>1010-1647</b>	Repl. mount For 07-17 XL models with Hypercharger, Pro-Hyper or Pro-R air cleaners	<b>79.99</b>
<b>DS-288826</b>	Adjustable enricher for S&S E and G carbs on 93-99 Big Twin and 91-06 XL models	<b>21.99</b>
<b>1010-1641</b>	Chrome Hypercharger back half, late inlet	<b>41.99</b>
<b>1010-0146</b>	Chrome blood groove trap door	<b>24.99</b>
<b>1010-1006</b>	Gloss black blood groove trap door	<b>24.99</b>
<b>1010-0329</b>	Chrome trap door	<b>20.99</b>
<b>1010-0347</b>	Black trap door	<b>18.99</b>
<b>1010-0332</b>	Chrome butterflies	<b>14.99</b>
<b>1010-0348</b>	Black butterflies	<b>14.99</b>
<b>1010-1540</b>	Repl. butterfly shaft	<b>9.99</b>
<b>DS-288825</b>	Repl. K&N filter element for Hyperchargers	<b>44.99</b>
<b>1011-3598</b>	Optional pre-filter element for standard Hyperchargers	<b>31.99</b>
<b>1012-0170</b>	Repl. rubber boots and hoses for Evolution crankcase breather kit	<b>8.99</b>
<b>1010-1583</b>	Repl. 1" breather bolts (pr.)	<b>10.99</b>
<b>1012-0198</b>	Repl. rubber boots for PART #1012-0170	<b>5.99</b>
<b>1012-0201</b>	Formed breather hoses for Twin Cam breather kit	<b>7.99</b>
<b>1010-1645</b>	5/8" air cleaner spacer	<b>20.99</b>



**UPGRADE KIT FOR CV TYPE HYPERCHARGER™ WITH OLD SHAFT DESIGN**

- Great way to update the look of your Hypercharger™
- Lets you keep your custom color doors and butterflies
- Has late-style carburetor inlet pattern

PART #	DESCRIPTION	SUG. RETAIL
<b>1010-1570</b>	Upgrade kit (includes chrome front and rear halves, shaft and end caps)	<b>\$89.99</b>



**CHROME SKULL AIR CLEANER KIT**

- Extremely rigid, high-strength composite construction
- Includes outer cover, backing plate, high-flow air filter element and all necessary brackets, crankcase breathers and other required hardware included
- Sold each

PART #	DESCRIPTION	SUG. RETAIL
<b>1010-1060</b>	For 07-17 XL	<b>\$239.99</b>



**1013-0022**

**ADAPTER/REPLACEMENT COMPONENTS FOR TWIN VELOCITY™ PLUS AIR CLEANER KITS**

•Sold each

PART #	DESCRIPTION	SUG. RETAIL
<b>1013-0022</b>	Adapter for Mikuni HSR 42/54/48 carburetor for 93-06 Evolution or Twin Cam	<b>\$46.99</b>
<b>DS-288863</b>	Repl. primary K&N filter element	<b>59.99</b>
<b>DS-288862</b>	Repl. small K&N filter element	<b>10.99</b>



**DS-288863**

**DS-288862**

**DISCLAIMER:** NOT LEGAL FOR SALE OR USE IN CALIFORNIA ON ANY POLLUTION CONTROLLED MOTOR VEHICLES. SEE PAGE 399 FOR IMPORTANT EMISSION DEFINITIONS AND REGULATORY COMPLIANCE AND WARRANTY INFORMATION.

All part numbers in **BLUE** are new for 2017.



**ALLEY CAT AIR CLEANERS**

- Combines Kuryakyn's high-flow Street Sweeper® air cleaner with the sleek new Alley Cat cover into one easy-to-install kit
- Features a high-flow parabolic curve entry to the throttle body
- Includes a re-useable high-flow K&N filter element
- Can support engine builds that produce more than 150 horsepower

PART #	DESCRIPTION	SUG. RETAIL
<b>CHROME</b>		
<b>1010-1410</b>	For 08-16 FLHR/FLHT/FLHX/FLTR/H-D FL Trike, 16-17 FXDLS, 16-17 Softail, 14-15 FLSTNSE, 11-12 FLSTSE, 13-14 FXSBSE	<b>\$289.99</b>
<b>1010-1415</b>	For 99-17 Twin Cam w/ CV carb or Delphi EFI (except 08-17 FLHR/FLHT/FLHX/FLTR/H-D FL Trike, 16-17 FXDLS, 16-17 Softail, 14-15 FLSTNSE, 11-12 FLSTSE, 13-14 FXSBSE)	<b>289.99</b>
<b>BLACK AND CHROME</b>		
<b>1010-1416</b>	For 08-16 FLHR/FLHT/FLHX/FLTR/H-D FL Trike, 16-17 FXDLS, 16-17 Softail, 14-15 FLSTNSE, 11-12 FLSTSE, 13-14 FXSBSE	<b>289.99</b>
<b>1010-1417</b>	For 99-17 Twin Cam w/ CV carb or Delphi EFI (except FLHR/FLHT/FLHX/FLTR/H-D FL Trike, 16-17 FXDLS, 16-17 Softail, 14-15 FLSTNSE, 11-12 FLSTSE, 13-14 FXSBSE)	<b>289.99</b>

**STREET SLEEPER™ II AIR CLEANERS**

- Incorporates the Hi-Five high-flow air filter element in an air cleaner that retains the stock oval air cleaner cover
- High-flow parabolic curve air entry to the throttle body
- Low profile of stock air cleaner means plenty of legroom for comfort
- Has a re-usable K&N high-flow air filter element
- Can support engines making more than 150 horsepower



PART #	DESCRIPTION	SUG. RETAIL
<b>1010-1059</b>	For 99-17 Twin Cam w/ CV carb or Delphi EFI (except 08-17 FLHR/FLHT/FLHX/FLTR/H-D FL Trike, 16-17 FXDLS, 16-17 Softail, 14-15 FLSTNSE, 11-12 FLSTSE, 13-14 FXSBSE)	<b>\$179.99</b>

**PRE-FILTER FOR MACH 2 AND ALLEY CAT AIR CLEANERS**

- Keep bugs, dirt, wash water, or torrential downpour out of your air cleaner
- Water repellent, UV-resistant and filters debris down to .005"

PART #	DESCRIPTION	SUG. RETAIL
<b>1011-3324</b>	Pre-filter for Mach 2 and Alley Cat air cleaners	<b>\$31.99</b>



**DISCLAIMER:** NOT LEGAL FOR SALE OR USE IN CALIFORNIA ON ANY POLLUTION CONTROLLED MOTOR VEHICLES. SEE PAGE 399 FOR IMPORTANT EMISSION DEFINITIONS AND REGULATORY COMPLIANCE AND WARRANTY INFORMATION.

All part numbers in **BLUE** are new for 2017.

WINDSHIELDS & FAIRINGS

AUDIO & VIDEO

SADDLEBAGS & LUGGAGE

SEATS & SISSY BARS

EXHAUST

FUEL/AIR SYSTEMS

ENGINE

TRANSMISSION & DRIVELINE

GASKETS & SEALS

ELECTRICAL

LIGHTING

HANDLEBARS, CONTROLS & MIRRORS

CABLES

BRAKES

TANKS & OIL FILTERS

DASHES & GAUGES

FRAMES & SUSPENSION

FENDERS & LICENSE PLATE FRAMES

FOOTRESTS

WHEELS & AXLES

HARDWARE, COVERS & GENERAL

## KURYAKYN

### VELOCIRAPTOR® AIR CLEANER

- Racing-inspired design and show bike styling
- Breathes well and filters the air
- Element is washable
- Insert covers up the mounting bolts, delivering smooth airflow into your motor
- Can support engines up to 90 hp
- PART #1010-1567 is an assembly (CV bolt pattern) that can be used with adapters, brackets or mounting kits to cover applications that do not have a specific kit



PART #	DESCRIPTION	SUG. RETAIL
<b>CHROME</b>		
<b>1010-1414</b>	For 08-16 FLHR/FLHT/FLHX/FLTR/H-D FL Trike, 16-17 FXDLS, 16-17 Softail, 14-15 FLSTNSE, 11-12 FLSTSE, 13-14 FXSBSE	\$169.99
<b>1010-1413</b>	For 99-17 Twin Cam w/ CV Carb or Delphi EFI (except 08-17 FLHR/FLHT/FLHX/FLTR/H-D FL Trike, 16-17 FXDLS, 16-17 Softail, 14-15 FLSTNSE, 11-12 FLSTSE, 13-14 FXSBSE)	169.99
<b>1010-1412</b>	For 93-99 Evolution Big Twin w/ stock carb	169.99
<b>1010-1419</b>	For 07-17 XL models	169.99
<b>1010-1411</b>	For 91-06 XL models	169.99
<b>1010-1567</b>	Velociraptor air cleaner assembly only	139.99

PART #	DESCRIPTION	SUG. RETAIL
<b>GLOSS BLACK</b>		
<b>1010-1652</b>	For 08-16 FLHR/FLHT/FLHX/FLTR/H-D FL Trike, 16-17 FXDLS, 16-17 Softail, 14-15 FLSTNSE, 11-12 FLSTSE, 13-14 FXSBSE	\$169.99
<b>1010-1651</b>	For 99-17 Twin Cam w/ CV Carb or Delphi EFI (except 08-17 FLHR/FLHT/FLHX/FLTR/H-D FL Trike, 16-17 FXDLS, 16-17 Softail, 14-15 FLSTNSE, 11-12 FLSTSE, 13-14 FXSBSE)	169.99
<b>1010-1971</b>	For 93-99 Evolution Big Twin w/ stock carb	169.99
<b>1010-1650</b>	For 07-17 XL models	169.99
<b>1010-1970</b>	For 91-06 XL models	169.99

## CRUSHER

### MAVERICK AIR CLEANERS

- Available in chrome or black with embossed Crusher stainless steel badge
- Features a K&N lifetime filter element which offers a high-flow curved entry to the throttle body for optimum performance
- Can support engine builds in excess of 150 horsepower



PART #	DESCRIPTION	SUG. RETAIL
<b>FOR 08-16 FLHR/FLHT/FLHX/FLTR/H-D FL TRIKE, 16-17 FXDLS, 16-17 SOFTAIL, 14-15 FLSTNSE, 13-14 FXSBSE AND 11-12 FLSTSE</b>		
<b>1010-1791</b>	Black	\$359.99
<b>1010-1796</b>	Chrome	359.99
<b>FOR 99-17 TWIN CAM MODELS W/ CV CARB OR DELPHI EFI (EXCEPT 08-17 FLHR/FLHT/FLHX/FLTR/H-D FL TRIKE, 16-17 FXDLS, 16-17 SOFTAIL, 14-15 FLSTNSE, 13-14 FXSBSE AND 11-12 FLSTSE)</b>		
<b>1010-1790</b>	Black	359.99
<b>1010-1795</b>	Chrome	359.99
<b>FOR 93-99 EVOLUTION BIG TWIN W/ CV CARB</b>		
<b>1010-1797</b>	Black	359.99
<b>1010-1798</b>	Chrome	359.99

PART #	DESCRIPTION	SUG. RETAIL
<b>FOR 07-17 XL MODELS</b>		
<b>1010-1789</b>	Black	\$359.99
<b>1010-1794</b>	Chrome	359.99
<b>FOR 91-06 XL MODELS W/ CV CARB</b>		
<b>1010-1788</b>	Black	359.99
<b>1010-1793</b>	Chrome	359.99
<b>AIR CLEANER ASSEMBLY ONLY FOR CUSTOM APPLICATIONS (REQUIRES SEPARATE PURCHASE OF ADAPTERS, BRACKETS OR MOUNTING KITS)</b>		
<b>1010-1787</b>	Black	329.99
<b>1010-1792</b>	Chrome	359.99

## BAHN

### BAHN AIR CLEANERS

- Complete your Bahn theme with this high-quality forged aluminum air cleaner cover that blankets a Bahn-designed high-flow K&N filter element with large openings in the outer cage to help support high-horsepower engine builds
- The rounded back mounting plate provides smooth-flowing air to the motor thanks to the large radius of the air induction inlet
- Include everything required for model-specific installation
- Complete the look with other products in the Bahn™ line
- Available with a chrome or Tuxedo (black with machined accents) finish



PART #	DESCRIPTION	SUG. RETAIL
<b>FOR 08-16 FLHR/FLHT/FLHX/FLTR/H-D FL TRIKE, 16-17 FXDLS, 16-17 SOFTAIL, 14-15 FLSTNSE, 13-14 FXSBSE AND 11-12 FLSTSE</b>		
<b>1010-1715</b>	Tuxedo	\$369.99
<b>1010-1716</b>	Chrome	369.99
<b>FOR 99-17 TWIN CAM W/ CV CARB OR DELPHI EFI (EXCEPT 08-17 TOURING/TRIKE, 16-17 FXDLS, 16-17 SOFTAILS, 11-12 FLSTSE, 13-14 FXSBSE AND 14-15 FLSTNSE)</b>		
<b>1010-1713</b>	Tuxedo	369.99
<b>1010-1714</b>	Chrome	369.99
<b>FOR 93-99 EVOLUTION BIG TWIN W/ CV CARB</b>		
<b>1010-1705</b>	Tuxedo	369.99
<b>1010-1706</b>	Chrome	369.99

PART #	DESCRIPTION	SUG. RETAIL
<b>FOR 07-17 XL</b>		
<b>1010-1711</b>	Tuxedo	\$369.99
<b>1010-1712</b>	Chrome	369.99
<b>FOR 91-06 XL W/ CV CARB</b>		
<b>1010-1709</b>	Tuxedo	369.99
<b>1010-1710</b>	Chrome	369.99
<b>AIR CLEANER ASSEMBLY ONLY FOR CUSTOM APPLICATIONS (REQUIRES PURCHASE OF ADAPTERS, BRACKETS OR MOUNTING KITS)</b>		
<b>1010-1707</b>	Tuxedo	339.99
<b>1010-1708</b>	Chrome	339.99

**DISCLAIMER:** NOT LEGAL FOR SALE OR USE IN CALIFORNIA ON ANY POLLUTION CONTROLLED MOTOR VEHICLES. SEE PAGE 399 FOR IMPORTANT EMISSION DEFINITIONS AND REGULATORY COMPLIANCE AND WARRANTY INFORMATION.

All part numbers in BLUE are new for 2017.

**ASSAULT SERIES**



1010-2047



1010-2049

WINDSHIELDS & FAIRINGS

AUDIO & VIDEO

SADDLEBAGS & LUGGAGE

SEATS & SISSY BARS

EXHAUST

FUEL/AIR SYSTEMS

ENGINE

TRANSMISSION & DRIVELINE

GASKETS & SEALS

ELECTRICAL

LIGHTING

HANDLEBARS, CONTROLS & MIRRORS

CABLES

BRAKES

TANKS & OIL FILTERS

DASHES & GAUGES

FRAMES & SUSPENSION

FENDERS & LICENSE PLATE FRAMES

FOOTRESTS

WHEELS & AXLES

HARDWARE, COVERS & GENERAL

**ASSAULT CHARGE HIGH-FLOW AIR CLEANER**

- Durable Cerekote industrial-looking finishes
- Easy installation
- Dyno developed and tested
- Made in the U.S.A.

PART #	DESCRIPTION	SUG. RETAIL
<b>FOR 08 to 16 FLHT/ FLHR/ FLHX/ FLTR/ H-D FL TRIKE, 16-17 FXDLS, 16-17 SOFTTAILS, 14-15 FLSTNE AND 11-12 FLSTSE</b>		
1010-2046	Reverse cut	\$489.95
1010-2047	Polished	489.95
1010-2048	Chrome	489.95

PART #	DESCRIPTION	SUG. RETAIL
<b>FOR 01-17 TWIN CAM W/ DELPHI EFI, 93-06 BIG TWIN W/ CV CARBS (EXCEPT 08-17 TOURING, 16-17 FXDLS, 16-17 SOFTTAILS, 14-15 FLSTNE AND 11-12 FLSTSE)</b>		
1010-2049	Reverse cut	\$489.95
1010-2050	Chrome	489.95
1010-2051	Raw machined	489.95



**Boyesen**

**POWER X INTAKE**

- Air is power and Boyesen has channeled that power like never before
- Patented X-Wing design for more power and acceleration; X-Wing venturi increases air speed for added throttle response
- Complete kit includes backing plate with internal breather passageways, filter and mounting hardware
- Oil-free/washable filter is a poly cotton blend with an extra-large filter area for increased airflow; filters to 40 microns
- Available in polished silver or matte black finish
- Accepts stock air filter cover

PART #	DESCRIPTION	SUG. RETAIL
<b>FOR 08-16 FLHT/FLHR/FLHX/FLTR/H-D FL TRIKE AND 16-17 SOFTTAILS (EXCEPT FLSS/FLSTFBS) MODELS</b>		
1010-1017	Polished silver	\$229.95
1010-1018	Matte black	229.95

**TP ENGINEERING**  
TOTAL PERFORMANCE

**AIR CLEANER ASSEMBLY**

- Rugged aluminum construction with chrome finish
- Internal breather for clean look
- Increases airflow, yet maintains a low profile
- Made in the U.S.A.

PART #	DESCRIPTION	SUG. RETAIL
<b>FOR 08-16 FLHT/FLHR/FLTR/FLHX, H-D FL TRIKES AND 16-17 FXDLS, 16-17 SOFTTAILS, 14-15 FLSTNE, 11-12 FLSTSE, 13-14 FXSBSE</b>		
1010-1404	Air cleaner	\$499.95
1011-3129	Repl. air filter	61.95

**DISCLAIMER:** NOT LEGAL FOR SALE OR USE IN CALIFORNIA ON ANY POLLUTION CONTROLLED MOTOR VEHICLES. SEE PAGE 399 FOR IMPORTANT EMISSION DEFINITIONS AND REGULATORY COMPLIANCE AND WARRANTY INFORMATION.

All part numbers in **BLUE** are new for 2017.

WINDSHIELDS & FAIRINGS  
AUDIO & VIDEO  
SADDLEBAGS & LUGGAGE  
SEATS & SISSY BARS



**HIGH PERFORMANCE 6" DRAGTRON™ II AIR CLEANER**

- Dynamometer-designed radius entry backing plate maximizes airflow and horsepower
- 2" washable filter is encased in a heavy stainless steel mesh and is easily serviced
- Available in chrome finish
- Stainless steel hardware is included
- Replacement filters available; see page 690



**NOTE:** Support brackets and breather kits are sold separately.  
U.S. Design Patent #305,149; Taiwan Patent pending.

PART #	DESCRIPTION	SUG. RETAIL
DS-289044	For 90-06 Big Twin, 88-06 XL (CV carbs) (Delphi EFI applications will require adapters PART #s 1010-0552 or 1010-0553; sold separately)	\$89.95

FUEL/AIR SYSTEMS  
ENGINE  
TRANSMISSION & DRIVELINE



DS-288999

**STAMPED STEEL DRAGTRON™-STYLE AIR CLEANER**

- Stamped steel version of our popular die-cast Dragtron air cleaner
- Fits Bendix, Keihin (not CV) and Tillotson carburetors



**"BOB" RETRO-STYLE AIR CLEANERS**

- Retro-style air cleaner measures 5 1/2" in diameter
- Has a reuseable foam filter element
- All necessary mounting hardware included
- Replacement filter element available separately



1010-1609

1010-0192

**NOTE:** Requires appropriate breather/carb support bracket.

PART #	DESCRIPTION	SUG. RETAIL	PART #	DESCRIPTION	SUG. RETAIL
DS-288999	Air cleaner	\$35.95	1010-0192	Chrome	\$69.95
DS-289043	Repl. foam element	4.95	1010-1610	Black	71.95
			<b>REPLACEMENT COMPONENTS</b>		
			1011-0881	Air filter element	14.95

LIGHTING  
HANDLEBARS, CONTROLS & MIRRORS  
CABLES  
BRAKES



DS-288903

**7" ROUND AIR CLEANERS**

- Chrome air cleaners fit Harley models equipped with Bendix, Keihin carburetors or Delphi EFI
- PART # DS-288998 Requires a support brace or a brace/breather kit for models listed (sold separately)
- Air filter included

PART #	DESCRIPTION	SUG. RETAIL
DS-288903	For 01-17 Twin Cam w/ Delphi EFI, 90-06 Big Twin and 88-06 XL models w/ OEM CV carb (except 08-17 FLHT/FLHR/FLTR/FLHX/H-D FL Trike, 16-17 FXDLS, 16-17 Softails)	\$49.95
DS-288998	For Bendix and Keihin (not CV) carbs	39.95



1010-1663

**DOG DISH AIR CLEANER ASSEMBLY**

- Features a hand-spun 5 3/8" polished aluminum cover with a high-quality element for high flow as well as superior protection from dust and dirt
- Includes a black powder-coated backing plate and all necessary mounting hardware
- Made in the U.S.A.



**NOTE:** Will require the separate purchase of a crankcase breather/carb support bracket kit.

PART #	DESCRIPTION	SUG. RETAIL
1010-1663	For CV carb	\$109.95
1010-1664	For S&S Super E carb	109.95

TANKS & OIL FILTERS  
DASHES & GAUGES  
FRAMES & SUSPENSION  
FENDERS & LICENSE PLATE FRAMES

**TEARDROP AIR CLEANER ASSEMBLIES**

- Chrome-plated cast aluminum construction
- Ribbed design
- Measures 8" L x 4 1/2" H x 2" D
- Include mini air filter and all necessary fittings and hardware
- Made in the U.S.A.



1010-0710

**NOTE:** PART #0708-0710 requires the use of a support bracket and breather kit (as needed).



1010-0711

PART #	DESCRIPTION	SUG. RETAIL
1010-0710	For S&S Super E and Super G carbs	\$174.95
1010-0711	For 01-07 Twin Cam w/ Delphi fuel injection and 93-06 Big Twin w/ Keihin CV carbs	174.95

**DISCLAIMER:** NOT LEGAL FOR SALE OR USE IN CALIFORNIA ON ANY POLLUTION CONTROLLED MOTOR VEHICLES.  
SEE PAGE 399 FOR IMPORTANT EMISSION DEFINITIONS AND REGULATORY COMPLIANCE AND WARRANTY INFORMATION.

All part numbers in **BLUE** are new for 2017.



1010-0417



1010-1818



1011-2882



1010-1107



1010-0671



1010-0322

**RK-SERIES AIR INTAKE SYSTEMS**

- Guaranteed increase in horsepower
- Replaces the stock air filter and cleaner backing plate assembly
- Fits behind the OE air cleaner cover maintaining the factory appearance
- Oversized black powder-coated aluminum backing plate provides solid mounting
- Dyno tuned velocity stack directs airflow to engine
- Built in breathers replace external OE breathers
- Washable, oversized K&N high flow air filter equals longer life
- Made in the U.S.A.

PART #	DESCRIPTION	SUG. RETAIL
<b>FOR 08-13 FLHT/FLHR/FLHX/FLTR</b>		
1010-0417	Large capacity filter assembly; 1 <sup>5</sup> / <sub>8</sub> " tall	\$288.95
1011-1509	Repl. air filter for large capacity filter assembly PART #1010-0417; 1 <sup>5</sup> / <sub>8</sub> " tall	96.95
<b>FOR 13-15 FLSTC/FLSTF/FLSTFB/FLSTN/FXSB</b>		
1010-1818	Large capacity filter assembly; 2 <sup>1</sup> / <sub>4</sub> " tall	209.95
1011-2882	Repl. air filter for PART #1010-1818; 2 <sup>1</sup> / <sub>4</sub> " tall	86.95
<b>FOR 99-06 TWIN CAM W/CV CARB, 01-17 TWIN CAM W/ DELPHI EFI (EXCEPT 16-17 FXDLS, 16-17 SOFTAIL, 08-17 FLSTSB/DYNA AND 08-17 DRESSER)</b>		
1010-1107	Large capacity filter assembly; 2 <sup>1</sup> / <sub>4</sub> " tall	227.95
1011-2868	Stock capacity filter assembly; 1 <sup>5</sup> / <sub>8</sub> " tall	267.95
1011-2882	Repl. air filter for large capacity filter assembly for PART #1010-1107; 2 <sup>1</sup> / <sub>4</sub> " tall	86.95
<b>FOR 08, 10-17 FXDWG, 08-17 FXD/FXDB/FXDC/FXDF/FXDL (EXCEPT 16-17 FXDLS, 13-17 FXDB)</b>		
1010-0671	Large capacity filter assembly; 2 <sup>1</sup> / <sub>8</sub> " tall	262.95
<b>FOR 04-17 XL (EXCEPT 13-17 1200V/1200X/883N)</b>		
1010-0322 <sup>1</sup>	Large capacity filter assembly; 2 <sup>1</sup> / <sub>4</sub> " tall	476.95
1011-1451	Repl. air filter for large capacity filter assembly for PART #1010-0322; 2 <sup>5</sup> / <sub>8</sub> " tall	90.95

<sup>1</sup> Does not include cover.

**DISCLAIMER:** NOT LEGAL FOR SALE OR USE IN CALIFORNIA ON ANY POLLUTION CONTROLLED MOTOR VEHICLES. SEE PAGE 399 FOR IMPORTANT EMISSION DEFINITIONS AND REGULATORY COMPLIANCE AND WARRANTY INFORMATION. All part numbers in BLUE are new for 2017.

WINDSHIELDS & FAIRINGS

AUDIO & VIDEO

SADDLEBAGS & LUGGAGE

SEATS & SISSY BARS

EXHAUST

FUEL/AIR SYSTEMS

ENGINE

TRANSMISSION & DRIVELINE

GASKETS & SEALS

ELECTRICAL

LIGHTING

HANDLEBARS, CONTROLS & MIRRORS

CABLES

BRAKES

TANKS & OIL FILTERS

DASHES & GAUGES

FRAMES & SUSPENSION

FENDERS & LICENSE PLATE FRAMES

FOOTRESTS

WHEELS & AXLES

HARDWARE, COVERS & GENERAL

WINDSHIELDS & FAIRINGS

AUDIO & VIDEO

SADDLEBAGS & LUGGAGE

SEATS & SISSY BARS

EXHAUST

FUEL/AIR SYSTEMS

ENGINE

TRANSMISSION & DRIVELINE

GASKETS & SEALS

ELECTRICAL

LIGHTING

HANDLEBARS, CONTROLS & MIRRORS

CABLES

BRAKES

TANKS & OIL FILTERS

DASHES & GAUGES

FRAMES & SUSPENSION

FENDERS & LICENSE PLATE FRAMES

FOOTRESTS

WHEELS & AXLES

HARDWARE, COVERS & GENERAL



1010-2014



1010-2017

1010-1105



1010-1106



1010-1597

**STREET METAL™ AIR INTAKE SYSTEMS**

- Guaranteed increase in horsepower
- Aluminum backing plate with an integrated velocity stack provides a solid mounting surface
- Built in breathers replace external OE breathers
- Developed around an over-sized K&N high-flow air filter that is designed to boost performance, filtration and service intervals
- High-quality aluminum cover with mirror or textured black finish
- Made in the U.S.A.



RK3901



RK3912



1010-1598

PART #	DESCRIPTION	SUG. RETAIL
<b>FOR 08-16 FLHR/FLHT/FLHX/FLTR, H-D FL TRIKE, 16-17 FXDLS AND 16-17 SOFTAILS</b>		
1010-1512	Grind, mirror	\$389.95
1010-1514	Weld, mirror	484.95
1010-2014	Hammer, mirror	498.95
1010-2015	Hammer, black	389.95
1010-2016	Flare, mirror	389.95
1010-2017	Flare, black	339.95
1010-2012	Flare, mirror (Large capacity) 3 1/8"	374.95
1010-2018	Flare, black (Large capacity) 3 1/8"	319.95
<b>FOR 99-06 TWIN CAM W/ CV CARB, 01-17 TWIN CAM W/ DELPHI EFI (EXCEPT 16-17 FXDLS, 16-17 SOFTTAILS AND 08-17 DRESSERS)</b>		
1010-1105	Flare, mirror	291.95
1010-1106	Hammer, mirror	291.95
1010-1597	Torch, mirror	579.95

PART #	DESCRIPTION	SUG. RETAIL
<b>FOR 92-99 80" BIG TWIN W/ OEM CARB</b>		
RK3901	Weld, mirror	\$396.95
RK3902	Torch, mirror	298.95
RK3912	Flux, mirror	409.95
<b>FOR 91-06 XL W/ OEM CARB</b>		
RK3903	Weld, mirror	298.95
RK3904	Torch, mirror	262.95
1010-1598	Grind, mirror	369.95
<b>REPLACEMENT FILTERS/DRYCHARGERS</b>		
E-3333	Teardrop for Flux/Torch style	70.95
RK-3901PK	Drycharger for round Grind/Weld style	27.95



1010-0314



1011-1058



1011-1059



1011-1060

**CUSTOM AIR CLEANER ASSEMBLIES**

- Designed to fit Harley-Davidson motorcycles equipped with various carburetors
- Increases horsepower with proper carburetor calibration
- These air cleaners mount directly to the carburetor flange
- Made in the U.S.A.

PART #	DESCRIPTION	SUG. RETAIL
1010-0314	For 84-89 Keihin butterfly carbs; 5" dia. and polished outer cover (excluding all S&S E & G carbs)	\$99.95
1011-1058	36-38mm Mikuni air filter; 5" dia. open round style	76.95
1011-1059	36-38mm Mikuni air filter; 6" dia. chrome bonnet style	99.95
RC-0920	40-45mm Mikuni air filter; 5" dia. open round style	80.95
1011-1060	40-45mm Mikuni air filter; 6" dia. chrome bonnet style	99.95
1011-2661	Repl. filter for 1011-1059	71.95
1011-2662	Repl. filter for 1011-1060	71.95

**DISCLAIMER:** NOT LEGAL FOR SALE OR USE IN CALIFORNIA ON ANY POLLUTION CONTROLLED MOTOR VEHICLES. SEE PAGE 399 FOR IMPORTANT EMISSION DEFINITIONS AND REGULATORY COMPLIANCE AND WARRANTY INFORMATION.

All part numbers in **BLUE** are new for 2017.



**EVIL TWIN DUAL AIR CLEANER KIT**

- Delivers an aggressive, sinister style with maximum airflow
- Fits with 5-gallon fuel tanks
- Chrome finish
- Made in the U.S.A.

PART #	DESCRIPTION	SUG. RETAIL
<b>1010-0707</b>	For 01-17 Twin Cam or XL w/ Delphi EFI or 93-06 Big Twin w/ 40mm CV carb (except 08-17 Dressers/H-D FL Trikes and 16-17 FXDLS, 16-17 Softails)	<b>\$1,393.95</b>

**DRAG SPECIALTIES DESIGN AIR CLEANERS**

- Chrome air cleaner kit with spear- or twister-style cone designed exclusively for Drag Specialties
- Increase airflow approximately 10% more than an OEM air cleaner
- Include filter cone with 360° slots, K&N air filter, 90° chrome elbow and installation hardware
- Will accept D&M Bullet replacement cones
- Optional adapters allow mounting on various carbs (sold separately)
- Made in the U.S.A.



1015-0086



1015-0104

NOTE: Require the use of a D&M carb support bracket and breather kit (sold separately, see page 638).

PART #	DESCRIPTION	SUG. RETAIL	PART #	DESCRIPTION	SUG. RETAIL
<b>FOR 01-17 TWIN CAM OR XL W/ DELPHI EFI AND 90-06 BIG TWIN AND 88-06 XL W/ 40MM CV CARB (EXCEPT MODELS W/ FAIRING LOWERS)</b>			<b>FOR 01-17 TWIN CAM OR XL W/ DELPHI EFI AND 90-06 BIG TWIN AND 88-06 XL W/ 40MM CV CARB (EXCEPT MODELS W/ FAIRING LOWERS) (CONT)</b>		
<b>1015-0086</b>	Drag Specialties Spear air cleaner	<b>\$489.95</b>	<b>7807-0018</b>	Repl. air filter	<b>\$70.95</b>
<b>1015-0104</b>	Drag Specialties Twister air cleaner	<b>538.95</b>	<b>1011-1778</b>	Rain sock	<b>29.95</b>



7807-0017



1015-0071



1015-0066



1015-0073

**THE BULLET AIR CLEANERS**

- Chrome air cleaner with a bullet-shaped cone with 360° slots
- Increase airflow approximately 10% more than an OEM air cleaner
- Include bullet-shaped filter cone, K&N air filter, 90° elbow and installation hardware
- Available with black or chrome elbow
- Diamond-cut cones also available; scalloped design
- Made in the U.S.A.

NOTE: Require the use of a D&M carb-support bracket and breather kit (sold separately, see page 638).

<b>FOR 01-17 TWIN CAM OR XL W/ DELPHI EFI AND 90-06 BIG TWIN AND 88-06 XL W/ 40MM CV CARB (EXCEPT MODELS W/ FAIRING LOWERS)</b>					
PART #	DESCRIPTION	SUG. RETAIL	PART #	DESCRIPTION	SUG. RETAIL
<b>WITH CHROME ELBOW</b>			<b>WITH BLACK ELBOW</b>		
<b>7807-0017</b>	Chrome cone	<b>\$489.95</b>	<b>1015-0065</b>	Wrinkle black cone	<b>\$489.95</b>
<b>1015-0071</b>	Black diamond-cut cone	<b>594.95</b>	<b>1015-0066</b>	Black cone	<b>489.95</b>
			<b>1015-0073</b>	Black diamond-cut cone	<b>594.95</b>
			<b>7807-0018</b>	Repl. air filter	<b>70.95</b>

**DISCLAIMER:** NOT LEGAL FOR SALE OR USE IN CALIFORNIA ON ANY POLLUTION CONTROLLED MOTOR VEHICLES. SEE PAGE 399 FOR IMPORTANT EMISSION DEFINITIONS AND REGULATORY COMPLIANCE AND WARRANTY INFORMATION.

All part numbers in **BLUE** are new for 2017.



WINDSHIELDS & FAIRINGS

AUDIO & VIDEO

SADDLEBAGS & LUGGAGE

SEATS & SISSY BARS

EXHAUST

FUEL/AIR SYSTEMS

ENGINE

TRANSMISSION & DRIVELINE

GASKETS & SEALS

ELECTRICAL

LIGHTING

HANDLEBARS, CONTROLS & MIRRORS

CABLES

BRAKES

TANKS & OIL FILTERS

DASHES & GAUGES

FRAMES & SUSPENSION

FENDERS & LICENSE PLATE FRAMES

FOOTRESTS

WHEELS & AXLES

HARDWARE, COVERS & GENERAL



1015-0107



1015-0021



DS289544



DS289543



1010-1118

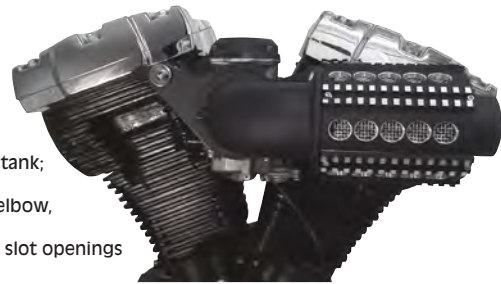

1010-1119

**POWER FLOW AIR CLEANERS**

- Provide the latest look and performance of forward-style intake systems
- Increase airflow approximately 20% more than an OEM air cleaner
- Can be installed horizontally or vertically when using a 3.5-gallon Fat Bob or smaller fuel tank; vertical adapter sold separately
- Include a CNC-machined billet filter cone with tapered, straight or Superslot slots, a 90° elbow, K&N air filter, gasket, hardware and wrench
- Diamond-cut cones also available; feature unique diamond-cut design on the edges of the slot openings
- Optional adapters allow mounting on various carbs (sold separately, see below)
- Made in the U.S.A.

NOTE: Requires a D&M carburetor support bracket and breather kit; sold separately.

**FOR 01-17 TWIN CAM AND XL W/ DELPHI EFI AND 90-06 BIG TWIN, 88-06 XL W/ 40MM CV CARBURETOR (EXCEPT MODELS WITH FAIRING LOWERS)**

PART #	DESCRIPTION	SUG. RETAIL	PART #	DESCRIPTION	SUG. RETAIL
<b>WITH CHROME ELBOW</b>			<b>WITH BLACK ELBOW</b>		
1015-0107	Chrome cone, Superslot	\$489.95	1015-0021	Wrinkle black cone, tapered slots	\$489.95
DS289544	Chrome cone, straight slots	489.95	1010-1119	Black Machine Gun	514.95
DS289543	Chrome cone, tapered slots	489.95	<b>RAIN SOCK AND REPLACEMENT FILTER</b>		
1010-1118	Chrome Machine Gun	514.95	1011-1779	Rain sock	32.95
			DS289549	Repl. air filter	70.95



1010-0992



1010-0993



1010-0994

**ULTIMATE FLOW AIR CLEANER KITS**

- Deliver massive airflow for peak performance at an economical price
- Lifetime filter is produced using the latest materials for maximum filtration and powerful airflow
- Filter is black media with a stainless steel end cap; also available with stainless steel wire
- Elbow is available with chrome, gloss black or wrinkle black finish
- Kits include elbow, filter, clamp, pre-filter and mounting hardware
- Made in the U.S.A.

NOTE: Requires use of a D&M support bracket/breather kit (sold separately, see page 638).

**FOR 01-17 TWIN CAM OR XL W/ DELPHI EFI, 90-06 BIG TWIN, 88-06 XL W/ 40MM CV CARB (EXCEPT MODELS WITH FAIRING LOWERS)**

PART #	DESCRIPTION	SUG. RETAIL	PART #	DESCRIPTION	SUG. RETAIL
<b>WITH CHROME ELBOW</b>			<b>WITH WRINKLE BLACK ELBOW</b>		
1010-0992	Black filter	\$262.95	1010-0994	Black filter	\$262.95
1010-0995	Black filter with stainless steel wire	267.95	<b>REPLACEMENT COMPONENTS</b>		
<b>WITH GLOSS BLACK ELBOW</b>			1011-2779	Black filter element	59.95
1010-0993	Black filter	262.95	1011-2780	Stainless steel filter element	65.95
1010-0996	Black filter with stainless steel wire	267.95			



DS289547

**AIR CLEANER ADAPTERS**

- For D&M Power Flow, Bullet, Hustler and Drag Specialties air cleaners
- Made in the U.S.A.

PART #	DESCRIPTION	SUG. RETAIL
7807-0118	S&S E and G carburetor (vertical or horizontal)	\$41.95
DS289547	40mm CV carburetor (vertical)	39.95

**DISCLAIMER:** NOT LEGAL FOR SALE OR USE IN CALIFORNIA ON ANY POLLUTION CONTROLLED MOTOR VEHICLES. SEE PAGE 399 FOR IMPORTANT EMISSION DEFINITIONS AND REGULATORY COMPLIANCE AND WARRANTY INFORMATION.

All part numbers in **BLUE** are new for 2017.

WINDSHIELDS & FAIRINGS

AUDIO & VIDEO

SADDLEBAGS & LUGGAGE

SEATS & SISSY BARS

EXHAUST

FUEL/AIR SYSTEMS

ENGINE

TRANSMISSION & DRIVELINE

GASKETS & SEALS

ELECTRICAL

LIGHTING

HANDLEBARS, CONTROLS & MIRRORS

CABLES

BRAKES

TANKS & OIL FILTERS

DASHES & GAUGES

FRAMES & SUSPENSION

FENDERS & LICENSE PLATE FRAMES

FOOTRESTS

WHEELS & AXLES

HARDWARE, COVERS & GENERAL



**TUNED INDUCTION AIR CLEANERS**

- Swept forward, two-in-one design rams additional air into the cylinder
- Natural supercharging effect increases mid-range torque
- Nearly twice the filter area of a teardrop air cleaner
- Feature chrome runner and bracket (except where noted), backing plate, filters and hardware
- Made in the U.S.A.

**NOTE:** Some applications exempt per CARB EXECUTIVE ORDER (EO) #D355-17. E.O. applies to 01-16 EFI models only.

PART #	DESCRIPTION	SUG. RETAIL
<b>1010-2003</b>	For 08-16 FLHT/FLHR/FLHX/FLTR/H-D FL Trike, 16-17 FXDLS, 16-17 Softails, 14-15 FLSTNSE, 13-15 FXSBSE, 11-12 FLTSE models with S&S Single Bore EFI (except models w/ fairing lowers) CARB EO# D-355-17	<b>\$439.95</b>
<b>1010-2004<sup>1</sup></b>	For 08-16 FLHT/FLHR/FLHX/FLTR/H-D FL Trike, 16-17 FXDLS, 16-17 Softail, 14-15 FLSTNSE, 13-15 FXSBSE, 11-12 FLTSE models with S&S Single Bore EFI (except models w/ fairing lowers)	<b>539.95</b>
<b>1010-2002</b>	For 01-17 Twin Cam w/ stock Delphi EFI, CARB EO# D-355-17 (except 08-17 Touring, 16-17 FXDLS, 16-17 Softails, 14-15 FLSTNSE, 13-15 FXSBSE and 11-12 FLTSE)	<b>539.95</b>
<b>1010-1079</b>	For 93-06 Big Twin models w/ stock CV carb	<b>539.95</b>
<b>1010-1083</b>	For 93-17 Big Twin models w/ S&S single-bore fuel-injection (except 08-17 Touring, 16-17 FXDLS, 16-17 Softails, 14-15 FLSTNSE, 13-15 FXSBSE and 11-12 FLTSE)	<b>539.95</b>
<b>1010-1084</b>	For 84-06 Big Twin models w/ S&S E/G series carb	<b>539.95</b>
<b>1010-2005</b>	For 07-17 XL w/ stock EFI, CARB EO# D-355-17	<b>539.95</b>
<b>1010-1082</b>	For S&S 124", 117", 111" motors w/ S&S 4 1/8" E/G series carb	<b>539.95</b>
<b>1010-1081</b>	For S&S 124", 117", 111" motors w/ S&S 4 1/8" single-bore fuel-injection	<b>539.95</b>
<b>REPLACEMENT COMPONENTS</b>		
<b>1011-0897</b>	Repl. red filter w/ clamp (ea.)	<b>52.95</b>
<b>1011-0898</b>	Opt. blue filter w/ clamp (ea.)	<b>52.95</b>
<b>1011-1336</b>	Moisture repellent rain cover for S&S tuned induction filters (pr.)	<b>49.95</b>

<sup>1</sup> Black.



**FAST AIR INTAKE SOLUTION**

- The most innovative and aggressive-looking forward-facing air intake on the market
- Features an internal crank case breather system
- K&N Filter element allows for a significant horsepower increase over stock air cleaner
- Available in chrome or Contrast Cut™ finishes
- Includes rain sock
- Made in the U.S.A.



PART #	DESCRIPTION	SUG. RETAIL
<b>FOR 08-16 FLHT/FLHR/FLHX/FLTR/ H-D FL TRIKE, 16-17 SOFTAIL, 16-17 FXDLS, 14-15 FLSTNSE, 13-14 FXSBSE AND 11-12 FLTSE</b>		
<b>1010-0986</b>	Contrast Cut	<b>\$499.95</b>
<b>1010-0987</b>	Chrome	<b>499.95</b>
<b>FOR 01-17 TWIN CAM W/ DELPHI EFI (EXCEPT 08-17 TOURING, 16-17 SOFTAIL, 16-17 FXDLS, 14-15 FLSTNSE, 13-14 FXSBSE AND 11-12 FLTSE), 93-06 BIG TWIN W/ CV CARB</b>		
<b>1010-0984</b>	Contrast Cut	<b>499.95</b>
<b>1010-0985</b>	Chrome	<b>499.95</b>
<b>FOR 91-17 XL</b>		
<b>1010-0988</b>	Contrast Cut	<b>499.95</b>
<b>REPLACEMENT COMPONENTS</b>		
<b>1011-2485</b>	Rain sock	<b>33.95</b>
<b>1011-2486</b>	Air filter	<b>64.95</b>

**DISCLAIMER:** NOT LEGAL FOR SALE OR USE IN CALIFORNIA ON ANY POLLUTION CONTROLLED MOTOR VEHICLES. SEE PAGE 399 FOR IMPORTANT EMISSION DEFINITIONS AND REGULATORY COMPLIANCE AND WARRANTY INFORMATION.

All part numbers in **BLUE** are new for 2017.

WINDSHIELDS & FAIRINGS

AUDIO & VIDEO

SADDLEBAGS & LUGGAGE

SEATS & SISSY BARS

EXHAUST

FUEL/AIR SYSTEMS

ENGINE

TRANSMISSION & DRIVELINE

GASKETS & SEALS

ELECTRICAL

LIGHTING

HANDLEBARS, CONTROLS & MIRRORS

CABLES

BRAKES

TANKS & OIL FILTERS

DASHES & GAUGES

FRAMES & SUSPENSION

FENDERS & LICENSE PLATE FRAMES

FOOTRESTS

WHEELS & AXLES

HARDWARE, COVERS & GENERAL



1010-1717



1010-1721



1010-1718

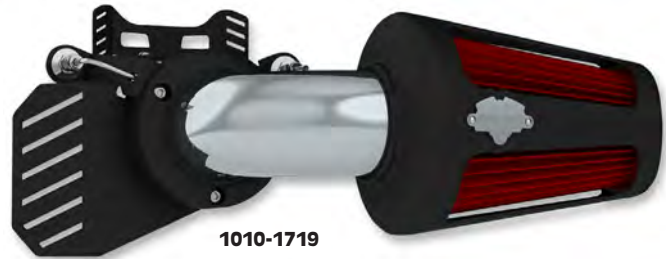

1010-1719



**VO2 90 AIR INTAKES**

- Feature a 90 degree intake elbow to increase air velocity in the combustion chamber for optimizing volumetric efficiency
- Increase performance over standard high-flow intakes
- Stylish open cage cover with riveted badge
- Crankcase breathers utilize stainless AN fittings
- Washable high-flow filter element
- Made in the U.S.A.

PART #	DESCRIPTION	SUG. RETAIL
<b>CHROME</b>		
1010-1717	For 08-16 FLHT/FLHR/FLHX/FLTR/H-D FL Trike, 16-17 Softails, 14-15 FLSTNSE, 13-14 FXSBSE and 11-12 FLSTSE models	\$499.99
1010-1720 <sup>1</sup>	For 01-17 Twin Cam w/ Delphi EFI, 99-06 Twin Cam w/CV carb (except 08-17 Dressers, 16-17 Softails, 14-15 FLSTNSE, 13-14 FXSBSE and 11-12 FLSTSE)	499.99
1010-1723	For 04-17 XL models	499.99
<b>BLACK</b>		
1010-1718	For 08-16 FLHT/FLHR/FLHX/FLTR/H-D FL Trike, 16-17 Softails, 14-15 FLSTNSE, 13-14 FXSBSE and 11-12 FLSTSE models	499.99

PART #	DESCRIPTION	SUG. RETAIL
<b>BLACK (CONT)</b>		
1010-1721 <sup>1</sup>	For 01-17 Twin Cam w/ Delphi EFI, 99-06 Twin Cam w/CV carb (except 08-17 Dressers, 16-17 Softails, 14-15 FLSTNSE, 13-14 FXSBSE and 11-12 FLSTSE)	\$499.99
1010-1724	For 04-17 XL models	499.99
<b>BLACK AND CHROME</b>		
1010-1719	For 08-16 FLHT/FLHR/FLHX/FLTR/H-D FL Trike, 16-17 Softails, 14-15 FLSTNSE, 13-14 FXSBSE and 11-12 FLSTSE models	499.99
1010-1722 <sup>1</sup>	For 01-17 Twin Cam w/ Delphi EFI, 99-06 Twin Cam w/CV carb (except 08-17 Dressers, 16-17 Softails, 14-15 FLSTNSE, 13-14 FXSBSE and 11-12 FLSTSE)	499.99
1010-1725	For 04-17 XL models	499.99

<sup>1</sup> Not for Dressers with fairing lowers.



1010-0560



1010-0344

**KURYAKYN**

**CORSAIR AIR CLEANER KITS**

- Aggressively styled, free-flowing high-performance air cleaner
- Chrome-plated die-cast housing features a high-flow air filter element supplied by Advanced Flow Engineering (aFe) for maximum performance, includes crankcase breather support bracket and all necessary installation hardware and brackets
- Will support engines making in excess of 100 horsepower
- Air cleaner extends approximately 6" straight out and 12<sup>1</sup>/<sub>2</sub>" forward of the engine

**NOTE:** Installation of this air cleaner may decrease rider legroom.

**NOTE:** Not for use on Twin-Cooled models.

PART #	DESCRIPTION	SUG. RETAIL
1010-0560	For 08-16 FLHT/FLHR/FLTR/FLHX, H-D FL Trikes, 16-17 FXDLS, 16-17 Softails, 14-15 FLSTNSE, 13-14 FXSBSE and 11-12 FLSTSE (except models w/ fairing lowers)	\$299.99
1010-0344	For 99-17 Twin Cam w/ CV carb or Delphi fuel injection (except 08-17 FLHT/FLHR/FLTR/FLHX, 16-17 FXDLS, 16-17 Softails, 14-15 FLSTNSE, 13-14 FXSBSE and 11-12 FLSTSE), 93-99 Evolution Big Twin w/ CV carb	299.99
1011-1380	Repl. air filter element	69.99

**DISCLAIMER:** NOT LEGAL FOR SALE OR USE IN CALIFORNIA ON ANY POLLUTION CONTROLLED MOTOR VEHICLES. SEE PAGE 399 FOR IMPORTANT EMISSION DEFINITIONS AND REGULATORY COMPLIANCE AND WARRANTY INFORMATION.

All part numbers in **BLUE** are new for 2017.

WINDSHIELDS & FAIRINGS

AUDIO & VIDEO

SADDLEBAGS & LUGGAGE

SEATS & SISSY BARS

EXHAUST

FUEL/AIR SYSTEMS

ENGINE

TRANSMISSION & DRIVELINE

GASKETS & SEALS

ELECTRICAL

LIGHTING

HANDLEBARS, CONTROLS & MIRRORS

CABLES

BRAKES

TANKS & OIL FILTERS

DASHES & GAUGES

FRAMES & SUSPENSION

FENDERS & LICENSE PLATE FRAMES

FOOTRESTS

WHEELS & AXLES

HARDWARE, COVERS & GENERAL



**AIRCHARGER® INTAKE SYSTEMS**

- K&N®High-Flow cotton air filter provides outstanding performance and protection
- Cast aluminum high-performance intake tube with raised detail
- Integrated internal velocity stack
- Built-in breathers replace external OE breathers
- Available in satin silver or satin black
- Optional Drycharger™ for increased protection from the elements is available separately



PART #	DESCRIPTION	SUG. RETAIL
<b>FOR 08-16 FLHR/FLHT/FLHX/FLTR/H-D FL TRIKES, 16-17 FXDLS AND 16-17 SOFTAIL (EXCEPT MODELS W/ FAIRING LOWERS)</b>		
1010-2025	Satin black	\$399.95
1010-2026	Satin silver	399.95

PART #	DESCRIPTION	SUG. RETAIL
<b>FOR 01-17 TWIN CAM W/ DELPHI EFI (EXCEPT 16-17 FXDLS, 16-17 SOFTAIL AND 08-16 FLHT/FLHR/FLHX/FLTR/H-D FL TRIKE)</b>		
1010-2027	Satin black	\$399.95
1010-2028	Satin silver	399.95
<b>OPTIONAL DRYCHARGER</b>		
1011-1520	Drycharger	33.95

1010-2019



**AIRCHARGER® PERFORMANCE INTAKE SYSTEMS**

- Custom built, providing an aggressive appearance and an increase in horsepower
- Custom aluminum throttle-body mounting plate
- Mandrel-bent aluminum high-flow intake tube
- K&N® High-Flow Air Filter™ designed to increase performance
- Includes complete breather assembly and mounting hardware
- Available in bright mirror or textured black finish
- Optional Drycharger™ for increased protection from the elements is available separately
- Made in the U.S.A.

1010-2022



1010-2023



1011-1520

NOTE: 50-State Street Legal

NOTE: CARB exempt per EO #D-269-55 Appendix A

PART #	DESCRIPTION	SUG. RETAIL
<b>For 08-14 FLHR/FLHT/FLHX/FLTR AND H-D FL TRIKE (EXCEPT MODELS W/ FAIRING LOWERS)</b>		
1010-2019	Textured black	\$468.95
1010-2020	Polished	509.95
<b>FOR 01-15 SOFTAIL/DYNA AND 02-07 FLHR/FLHT/FLHX/FLTR AND H-D FL TRIKE (EXCEPT MODELS W/ FAIRING LOWERS)</b>		
1010-2021	Textured black	474.95

PART #	DESCRIPTION	SUG. RETAIL
<b>FOR 01-15 SOFTAIL/DYNA AND 02-07 FLHR/FLHT/FLHX/FLTR AND H-D FL TRIKE (EXCEPT MODELS W/ FAIRING LOWERS) (CONT)</b>		
1010-2022	Polished	\$509.95
<b>FOR 07-14 XL 883/1200</b>		
1010-2023	Textured black	494.95
1010-2024	Polished	529.95
<b>OPTIONAL DRYCHARGER</b>		
1011-1520	Drycharger	33.95

1010-1980

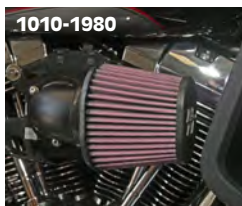

1010-1109



1010-0819



1010-1110



**AIRCHARGER® PERFORMANCE INTAKE SYSTEMS**

- K&N High-Flow air filter greatly increases performance and horsepower
- Mandrel bent aluminum intake tube
- Available in polished bright mirror or textured black
- Kit includes breather assembly and all necessary mounting hardware
- Optional Drycharger™ for increased protection from the elements is available separately
- Made in the U.S.A.



1010-1038



1011-3832



1011-1520

PART #	DESCRIPTION	SUG. RETAIL
<b>FOR 08-16 FLHR/FLHT/FLHX/FLTR/H-D FL TRIKES W/ FAIRING LOWERS</b>		
1010-1980	Textured black	\$468.95
<b>FOR 08-16 FLHR/FLHT/FLHX/FLTR/H-D FL TRIKES, 16-17 FXDLS AND 16-17 SOFTAIL (EXCEPT MODELS W/ FAIRING LOWERS)</b>		
1010-1109	Textured black	469.95
1010-0556	Polished	509.95
<b>FOR 01-17 TWIN CAM W/ DELPHI EFI (EXCEPT 16-17 FXDLS, 16-17 SOFTAIL AND 08-16 FLHT/FLHR/FLHX/FLTR/H-D FL TRIKE)</b>		
1010-1108	Textured black	488.95
1010-0819	Polished	509.95
<b>FOR 07-17 XL 883/1200</b>		
1010-1110	Textured black	479.95

PART #	DESCRIPTION	SUG. RETAIL
<b>FOR 07-17 XL 883/1200 (CONT)</b>		
1010-1038	Polished	\$465.95
<b>FOR 15-17 XG500/750</b>		
1011-3832	Textured black	298.95
<b>REPL. AIR FILTERS</b>		
1011-2620	For PART #s 1010-0811, 1010-0818 or 1010-0556; textured black	106.95
1011-2289	For PART #s 1010-0819 or 1010-0556; polished	66.95
1011-3836	For PART #1010-1980	77.95
<b>OPTIONAL DRYCHARGER</b>		
1011-1520	Drycharger	33.95

**DISCLAIMER:** NOT LEGAL FOR SALE OR USE IN CALIFORNIA ON ANY POLLUTION CONTROLLED MOTOR VEHICLES. SEE PAGE 399 FOR IMPORTANT EMISSION DEFINITIONS AND REGULATORY COMPLIANCE AND WARRANTY INFORMATION.

All part numbers in BLUE are new for 2017.



**VORTEX AIR CLEANER HOUSING**

- Simplicity of a raw performance part with a good mix of basic old school design and function
- Manufactured in die cast aluminum with CNC milled gasket surface
- Central porthole is thermoformed Lexan to increase flow and to watch that spray of raw fuel when you grab a handful of throttle
- Lightweight and functional
- Includes stainless steel back plate and hardware
- Air filter element will need to be ordered separately; not included, order K&N PART #TB10; does not include breathers
- Manufactured in die cast aluminum with CNC milled gasket surface
- Sold each
- Made in France

NOTE: Carb support brackets sold separately.



1010-2044



1010-2045

PART #	DESCRIPTION	SUG. RETAIL
<b>FOR 86-13 BIG TWIN AND XL WITH CV CARBURETOR OR DELPHI EFI UP TO 96 CU. IN. (EXCEPT 08-13 DRESSERS)</b>		
1010-2044	Black cut	\$328.95
1010-2045	Raw	303.95



**SMOOTH STYLE CARBURETOR COVER**

- Teardrop-style design
- Comes without element
- Available in chrome finish
- Made in the U.S.A.



PART #	DESCRIPTION	SUG. RETAIL
1015-0099	For 84-91 Big Twin w/ S&S carburetor	\$98.95



**AIR CLEANER ADAPTERS**

- Allow installation of a Dragtron II air cleaner (DS-289044) to models listed
- Plain machined finish

1010-0552

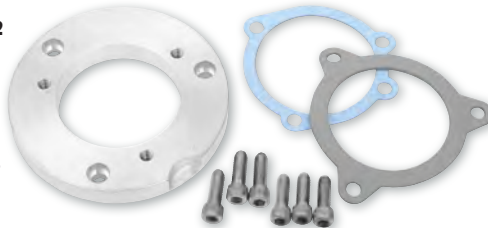

1010-0553



PART #	DESCRIPTION	SUG. RETAIL
1010-0552	For 08-16 FLHT/FLHR/FLTR/FLHX and H-D FL Trike models	\$27.95
1010-0553	For 01-17 models w/ Delphi EFI (except 08-17 Dressers/H-D FL Trike, 16-17 FXDLS and 16-17 Softtails)	22.95



**MIKUNI AIR CLEANER ADAPTER**

- Machined T-6061 billet aluminum construction
- Use to mount either an S&S E/G or Keihin CV style air cleaners to a Mikuni HSR 42/45 carb
- Made in the U.S.A.



1013-0059



1013-0060



**AIR CLEANER ADAPTERS**

- Allow installation of an L.A. Choppers xxx air cleaner or Baron Big Air Kit to a Mikuni or S&S carburetor
- Will also work for mounting other air cleaner kits designed to mount stock CV carburetors; not for use with Arlen Ness Big Sucker air cleaners
- Constructed from 6061 T-6 billet aluminum
- Made in the U.S.A.

PART #	DESCRIPTION	SUG. RETAIL
1013-0059	For Mikuni HSR42/45 carburetors	\$39.95
1013-0060	For S&S carburetors	39.95

**STOP-N-POP BOTTLE OPENER**

- Add a visual kick to your air cleaner or custom location of your choice
- Aluminum base construction with stainless steel bottle opener
- Base is ball-furnished finish, bottle opener is polished finish
- Installs using original air cleaner center mount bolt; mounting hardware for bottle opener included
- Mounts in just minutes, adding both functionality and bling
- Made in the U.S.A.



PART #	DESCRIPTION	SUG. RETAIL
1014-0110	For 99-17 Twin Cam w/ stock oval air cleaner cover (except 14-17 FLHT/FLHR/FLHX, 16-17 Softtail and 08-17 Dyna)	\$29.95

**DISCLAIMER:** NOT LEGAL FOR SALE OR USE IN CALIFORNIA ON ANY POLLUTION CONTROLLED MOTOR VEHICLES. SEE PAGE 399 FOR IMPORTANT EMISSION DEFINITIONS AND REGULATORY COMPLIANCE AND WARRANTY INFORMATION.

All part numbers in **BLUE** are new for 2017.



1014-0131

**ALLEY CAT AIR CLEANER COVERS**

- Designed to fit Kuryakyn Street Sleeper II high-flow air cleaner
- Also fits select H-D Screamin' Eagle and some other aftermarket air cleaners (see chart)
- Features a unique chrome mesh insert and "knock-off" style end cap for a retro look
- Cover only, not a complete air filter assembly
- Sold each

NOTE: Will not work on Arlen Ness Stage II Big Sucker air cleaner or original Kuryakyn Street Sleeper.

PART #	DESCRIPTION	SUG. RETAIL
<b>FOR 99-16 FLHT/FLHR/FLTR/FLHX, 00-17 FLST/FXST AND 99-07 DYNA W/ SCREAMIN' EAGLE STAGE I AIR CLEANER KIT; ALSO FITS KURYAKYN STREET SLEEPER II AND III AIR CLEANER OR ARLEN NESS STAGE I BIG SUCKER AIR CLEANER</b>		
1014-0131	Chrome	\$109.99
1014-0168	Black and chrome	109.99



**SCARAB AIR CLEANER COVER**

- Stylish upgrade for the OEM air cleaner assembly
- Contoured design adds a racy touch
- Chrome grille openings allow additional airflow

PART #	DESCRIPTION	SUG. RETAIL
1010-0716	For 02-13 FLHT/FLHR/FLTR/FLHX and H-D FL Trike (except CA models w/ carburetor), 01-15 FXST/FLST (except 11-13 FXS, 12-15 FLS, 08-11 FLSTSB and CA models w/ carburetor), 04-07 FXD/FXDVG	\$69.99

1010-1910



**QUANTUM AIR CLEANER COVERS**

- Feature sculpted 3D inserts with a larger-than-stock intake opening
- Direct replacement for stock air cleaner cover
- Quick and easy to install; uses stock mounting screw

NOTE: Can also be used on Screamin' Eagle Stage-1 Air Cleaner Kit.

1010-1911



PART #	DESCRIPTION	SUG. RETAIL
<b>FOR 14-16 FLHT/FLTR /FLHR/FLHX/H-D TRIKES AND 16-17 SOFTAILS, (EXCEPT 14-16 FLHTKSE, 15-16 FLTRUSE, 14 FLHRSE, 15-16 FLHXSE, 16 FLSTFBS</b>		
1010-1910	Gloss black	\$99.99
1010-1911	Chrome	99.99

**DISCLAIMER:** NOT LEGAL FOR SALE OR USE IN CALIFORNIA ON ANY POLLUTION CONTROLLED MOTOR VEHICLES. SEE PAGE 399 FOR IMPORTANT EMISSION DEFINITIONS AND REGULATORY COMPLIANCE AND WARRANTY INFORMATION.

All part numbers in **BLUE** are new for 2017.

WINDSHIELDS & FAIRINGS

AUDIO & VIDEO

SADDLEBAGS & LUGGAGE

SEATS & SISSY BARS

EXHAUST

FUEL/AIR SYSTEMS

ENGINE

TRANSMISSION & DRIVELINE

GASKETS & SEALS

ELECTRICAL

LIGHTING

HANDLEBARS, CONTROLS & MIRRORS

CABLES

BRAKES

TANKS & OIL FILTERS

DASHES & GAUGES

FRAMES & SUSPENSION

FENDERS & LICENSE PLATE FRAMES

FOOTRESTS

WHEELS & AXLES

HARDWARE, COVERS & GENERAL

**BILLET AIR CLEANER INSERTS**

- Available in a variety of designs
- Chrome finish, unless noted
- Sold each
- Made in the U.S.A.



1014-0093

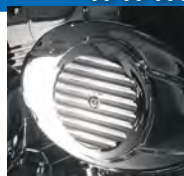

1015-0110



DS-288842



DS288829

PART #	DESCRIPTION	SUG. RETAIL
<b>FOR 99-16 TWIN CAM ROUND AIR CLEANER (EXCEPT 16 SOFTTAILS, 08-16 DYNA/14-16 FLHT/FLHR/FLTR)</b>		
1014-0093	Finned (black)	\$70.95
1015-0110	Finned	70.95

PART #	DESCRIPTION	SUG. RETAIL
<b>FOR 99-16 TWIN CAM ROUND AIR CLEANER (EXCEPT 16 SOFTTAILS, 08-16 DYNA/14-16 FLHT/FLHR/FLTR) (CONT)</b>		
DS-288841	Flame	\$70.95
DS-288842	Smooth	70.95
<b>FOR 84-99 EVOLUTION ROUND AIR CLEANER</b>		
DS288829	Flame	80.95

**AIR CLEANER INSERTS**

- Bolt-on inserts give a customized look to aftermarket or OEM air cleaner
- Constructed of billet aluminum and available in a chrome finish



DS-288819



DS-288820



1010-1318



1010-1320

PART #	DESCRIPTION	SUG. RETAIL
<b>FOR 99-16 TWIN CAM WITH OEM AIR CLEANER (EXCEPT 16 SOFTTAILS, 08-16 DYNA, 14-16 FLHT/FLHR/FLHX MODELS)</b>		
DS-288819	Millennium smooth, chrome	\$80.95
DS-288820	Millennium ball-milled, chrome	84.95
1010-1321	Millennium smooth, black	80.95

PART #	DESCRIPTION	SUG. RETAIL
<b>FOR 84-99 BIG TWINS</b>		
1010-1318	Millennium smooth, black	\$80.95
1010-1319	Millennium ball-milled, chrome	80.95
1010-1320	Millennium ball-milled, black	80.95

**CROSS SERIES AIR CLEANER INSERT**

- High-quality insert for a sleek, custom look
- Constructed of 6061 T-6 aluminum
- Available in black anodized with re-machined accents
- Easy installation
- Made in the U.S.A.



**FIVE-BOLT DOMED AIR CLEANER INSERT**

- Die-cast insert with a chrome finish
- Matches the five-bolt style of OEM derby cover



PART #	DESCRIPTION	SUG. RETAIL
1014-0112	For 99-16 Twin Cam w/ stock air cleaner cover (except 16 Softails, 08-16 Dyna, 14-16 FLHT/FLHR/FLHX Models)	\$94.95

PART #	DESCRIPTION	SUG. RETAIL
DS288929	For 99-16 Original Equipment Twin Cam air cleaners (except 16 Softail, 08-16 Dyna, 14-16 FLHT/FLHR/FLHX models)	\$42.95

**AIR CLEANER INSERTS**

- CNC-machined billet aluminum construction
- Finned style
- Made in the U.S.A.



1010-1035



1010-1036



1010-1037



1014-0158

PART #	DESCRIPTION	SUG. RETAIL	PART #	DESCRIPTION	SUG. RETAIL	PART #	DESCRIPTION	SUG. RETAIL
<b>FOR 99-16 OEM TWIN CAM AIR CLEANER (EXCEPT 16 SOFTTAIL, 08-16 DYNA, 14-16 FLHT/FLHR/FLHX)</b>			<b>MACHINE HEAD (CONT)</b>			<b>DIMPLED</b>		
<b>FINNED</b>			<b>1010-1036</b>			<b>1014-0157</b>		
1010-0415	Gloss black powdercoat	\$139.95	Chrome	\$159.95	1014-0157	Gloss black powdercoat	\$149.95	
<b>MACHINE HEAD</b>			<b>1010-1037</b>			<b>1014-0158</b>		
1010-1035	Gloss black powdercoat	159.95	Black diamond edge	219.95	1014-0158	Chrome	149.95	



**AIR CLEANER INSERTS**

- Fit VO2 Naked air intake, Screamin' Eagle and other aftermarket air cleaners with a round filter element and center-bolt mount
- 5 1/2" stamped steel covers feature subtle creasing reminiscent of old-school mag wheels
- Brilliant chrome, matte chrome or black ceramic finish
- Made in the U.S.A.



1010-0868



1010-0867



1010-1051



1014-0169



1010-1052

PART #	DESCRIPTION	SUG. RETAIL
<b>SKULLCAP</b>		
1010-0868	Chrome	\$79.99
1010-0867	Black	79.99

PART #	DESCRIPTION	SUG. RETAIL
<b>SKULLCAP CROWN</b>		
1010-1051	Chrome	\$79.99
1014-0169	Matte chrome	79.99
1010-1052	Black	79.99

**DISCLAIMER:** NOT LEGAL FOR SALE OR USE IN CALIFORNIA ON ANY POLLUTION CONTROLLED MOTOR VEHICLES. SEE PAGE 399 FOR IMPORTANT EMISSION DEFINITIONS AND REGULATORY COMPLIANCE AND WARRANTY INFORMATION.

All part numbers in **BLUE** are new for 2017.

WINDSHIELDS & FAIRINGS

AUDIO & VIDEO

SADDLEBAGS & LUGGAGE

SEATS & SISSY BARS

EXHAUST

FUEL/AIR SYSTEMS

ENGINE

TRANSMISSION & DRIVELINE

GASKETS & SEALS

ELECTRICAL

LIGHTING

HANDLEBARS, CONTROLS & MIRRORS

CABLES

BRAKES

TANKS & OIL FILTERS

DASHES & GAUGES

FRAMES & SUSPENSION

FENDERS & LICENSE PLATE FRAMES

FOOTRESTS

WHEELS & AXLES

HARDWARE, COVERS & GENERAL

1010-0836



1010-0835



**NOSTALGIA VELOCITY STACKS**

- High-velocity stacks include backing plate with breathers and screen
- CNC-machined billet aluminum
- Available in chrome or black anodized finish
- All mounting hardware included
- Made in the U.S.A.

PART #	DESCRIPTION	SUG. RETAIL
<b>FOR 91-17 XL</b>		
1010-0836	Chrome	\$449.95
1010-0835	Black anodized	449.95



**4" DEATH STACK**

- Chromed, CNC-machined billet aluminum velocity stack
- Incorporates crankcase breathers into the mounting bracket
- Stack screws onto mounting bracket for clean installation
- Made in the U.S.A.

PART #	DESCRIPTION	SUG. RETAIL
2106-1008	For 93-06 Big Twin w/ Mikuni HSR 42/45/48 carbs	\$326.95



**VELOCITY STACK PRE-FILTER**

- Compatible with all RSD velocity stacks
- Also fits on any 3 3/4" velocity stack
- Hydrophobic manufacturing process repels water
- Filters out larger particles of debris down to .005"
- Uniform micron openings allow air in while keeping debris and water out
- Made in the U.S.A.



PART #	DESCRIPTION	SUG. RETAIL
1011-2763	Velocity stack pre-filter	\$19.95



**AIR HORN KIT**

- Fully machined from lightweight alloy aluminum castings
- Kit includes: air horn, three mounting screws, carb support bracket (bracket connects the center crankcase bolt to the bottom manifold carburetor mounting bolt), two longer bottom carb-to-manifold mounting bolts and an enrichment device
- Fits Super E & G carbs

PART #	DESCRIPTION	SUG. RETAIL
1011-3843	Air horn kit	\$125.95



**REPLACEMENT SCREEN FOR VELOCITY STACKS**

- Replacement debris-catching screen
- Diameter measures 2.55"
- Made in the U.S.A.



PART #	DESCRIPTION	SUG. RETAIL
DS28869	Repl. screen for velocity stacks	\$2.95

**DISCLAIMER:** NOT LEGAL FOR SALE OR USE IN CALIFORNIA ON ANY POLLUTION CONTROLLED MOTOR VEHICLES. SEE PAGE 399 FOR IMPORTANT EMISSION DEFINITIONS AND REGULATORY COMPLIANCE AND WARRANTY INFORMATION.

All part numbers in BLUE are new for 2017.





WINDSHIELDS & FAIRINGS

AUDIO & VIDEO

SADDLEBAGS & LUGGAGE

SEATS & SISSY BARS

EXHAUST

FUEL/AIR SYSTEMS

ENGINE

TRANSMISSION & DRIVELINE

GASKETS & SEALS

ELECTRICAL

LIGHTING

HANDLEBARS, CONTROLS & MIRRORS

CABLES

BRAKES

TANKS & OIL FILTERS

DASHES & GAUGES

FRAMES & SUSPENSION

FENDERS & LICENSE PLATE FRAMES

FOOTRESTS

WHEELS & AXLES

HARDWARE, COVERS & GENERAL



1011-0320



1011-3218



1011-3219



1011-1203



1011-1902



1011-0322



1011-0319



1011-0318

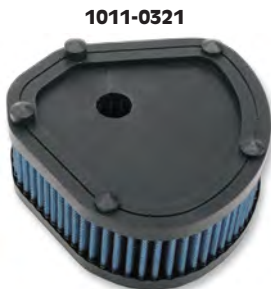

1011-0321



1011-0784



1011-1067



1011-0317



1011-0312

**PREMIUM REUSABLE AIR FILTERS**

- Durable epoxy-coated wire mesh designed to maximize airflow and provide peak filtration
- 100% reusable and washable
- Pre-oiled for quick, easy installation
- High-flow four-layer surgical-grade cotton filtration
- Urethane body won't crack or curl like rubber
- Precision hand-poured design
- Made in the U.S.A.

**YEAR MODEL**

**FOR BIG TWIN**

99-17	Twin Cam (except 08-17 Dresser/H-D FL Trike, 11-13 FXS, 12-16 FLS, 08-11 FLSTSB, 99-01 Magneti-Marelli EFI, 08-16 Dyna Glide)
14-16	14-16 FLHT/FLHR/FLHX/FLTR/H-D FL Trike and 16-17 Softail (except FLSS/FLSTFBS)
08-16	12-17 FLS, 11-13 FXS, 08-11 FLSTSB, 13-17 FXDB
08-13	FLHT/FLHR/FLTR/FLHX/H-D FL Trike
08-17	FXD/FXDB/FXDC/FXDF/FXDL/FXDWG/FLD (except 13-17 FXDB)
99-01	88" Twin Cam (w/ Magneti-Marelli EFI)
95-98	80" Evolution (w/ Magneti-Marelli EFI)
90-99	80" Evolution (carbureted)
86-89	80" Evolution (carbureted)
02-16	V-Rod

**FOR XL/BUELL**

04-13	XL Evolution (except 13 1200V)
88-03	XL Evolution
96-02	Buell (except 96 S2/S2T, 00-02 Blast)

**DRAG SPECIALTIES # K&N REF. # OEM #**

**SUG. RETAIL**

1011-0320	HD1499	29461-99, 29400042	<b>\$74.95</b>
1011-3218	-	29400045	<b>68.95</b>
1011-3219	HD-1611	29314-08	<b>68.95</b>
1011-1203	HD-1508	29633-08	<b>69.95</b>
1011-1902	HD-9608	29191-08	<b>69.95</b>
1011-0322	HD8899	29462-99	<b>77.95</b>
1011-0319	HD-1395	29291-95	<b>71.95</b>
1011-0318	HD-1390	29259-91A, 29330-96	<b>59.95</b>
1011-0321	HD-2086X	29259-86	<b>45.95</b>
1011-0784	HD-1102	29437-01	<b>67.95</b>
1011-1067	HD-8834	29331-04	<b>67.95</b>
1011-0317	HD-1388	29036-88/A/B, 29331-96	<b>65.95</b>
1011-0312	BU-1297	29239-96Y, P0213.9	<b>54.95</b>

**DISCLAIMER:** NOT LEGAL FOR SALE OR USE IN CALIFORNIA ON ANY POLLUTION CONTROLLED MOTOR VEHICLES. SEE PAGE 399 FOR IMPORTANT EMISSION DEFINITIONS AND REGULATORY COMPLIANCE AND WARRANTY INFORMATION.

All part numbers in **BLUE** are new for 2017.



**PREMIUM REUSABLE AIR FILTERS (CONT)**



- WINDSHIELDS & FAIRINGS
- AUDIO & VIDEO
- SADDLEBAGS & LUGGAGE
- SEATS & SISSY BARS
- EXHAUST
- FUEL/AIR SYSTEMS**

- ENGINE
- TRANSMISSION & DRIVELINE
- GASKETS & SEALS
- ELECTRICAL

- LIGHTING
- HANDLEBARS, CONTROLS & MIRRORS

- CABLES
- BRAKES

- TANKS & OIL FILTERS
- DASHES & GAUGES

- FRAMES & SUSPENSION
- FENDERS & LICENSE PLATE FRAMES

- FOOTRESTS
- WHEELS & AXLES

- HARDWARE, COVERS & GENERAL

YEAR MODEL	DRAG SPECIALTIES #	K&N REF. #	OEM #	SUG. RETAIL
<b>FOR AFTERMARKET AIR CLEANERS</b>				
- S&S "D" teardrop air filter	<b>1011-0313</b>	E-3224	-	<b>\$31.95</b>
- S&S 6" x 2 <sup>3</sup> / <sub>16</sub> " air filter	<b>1011-0314</b>	E-3225	-	<b>31.95</b>
- S&S Super E and G series carb air filter	<b>1011-0315</b>	E-3226	-	<b>31.95</b>
- Screamin' Eagle Stage 1 air filter 08-14 FLHTCUSE/FLHRSE	<b>1011-1204</b>	HD-0818	29244-08	<b>52.95</b>
- Screamin' Eagle Stage 1 air filter 14-16 FLHT/FLHR/FLHX/FLTR/H-D FL Trike and 16-17 Softtail (except FLSS/FLSTFBS)	<b>1011-3498</b> <sup>1</sup>	HD-0818	29244-08	<b>47.95</b>
- Screamin' Eagle Stage 1 air filter Evolution Big Twin	<b>1011-0316</b>	HD-0600	29055-89	<b>45.95</b>
- Screamin' Eagle Stage 1 air filter Twin Cam (except 99-01, 08-17 Dresser, 08-17 Dyna)	<b>1011-0528</b>	HD-0800	29442-99A	<b>47.95</b>
- Screamin' Eagle Stage 1 air filter 08-17 Dyna	<b>1011-1943</b>	HD-0808	29385-08	<b>37.95</b>
- Screamin' Eagle Stage 1 air filter 04-17 XL	<b>1011-0783</b>	HD-0900	29044-04	<b>64.95</b>
- Arlen Ness billet Sucker air filter Twin Cam (except 16-17 Softtail, 08-17 Dresser), Arlen Ness Stage 1 Big Sucker/Billet Sucker air filter for CV carb or Delphi EFI (except 16-17 Softtail, 08-17 Dresser)	<b>1011-0528</b>	HD-0800	29442-99A	<b>47.95</b>

<sup>1</sup> Must be used with OEM air cleaner cover.



**OEM STYLE REPLACEMENT AIR FILTER ELEMENTS**

- High-quality paper filter medium
- Meets or exceeds OEM specifications
- For use with OEM stock air filter housings

**NOTE: Not for use with Screamin' Eagle air cleaners.**

PART #	DESCRIPTION	SUG. RETAIL
<b>1011-2956</b>	For 99-16 Twin Cam (except 11-13 FXS, 12-17 FLS, 99-01 EFI models, 08-16 FLHT/FLHR/FLHX/FLTR and H-D FL Trike models, 08-15 Dyna Glide models, 08-11 FLSTSB); repl. OEM #s 29461-99/29400042	<b>\$24.95</b>
<b>1011-3178</b>	For 14-16 FLHR/FLHT/FLHX/FLTR/H-D FL Trikes, 16-17 Softtail (except FLSS/FLSTFBS); repl. OEM #29400045	<b>26.95</b>
<b>1011-2957</b>	For 08-13 FLHR/FLHT/FLHX/FLTR and H-D FL Trikes; repl. OEM #29633-08	<b>24.95</b>
<b>1011-2958</b>	For 08-17 FXD/FXDB/FXDC/FXDF/FXDL/FXDWG (except 16-17 FXDLS, 13-17 FXDB); repl. OEM #29191-08	<b>24.95</b>
<b>1011-3179</b>	For 13-17 FXDB, 12-17 FLS, 11-13 FXS, 08-11 FLSTSB models; repl. OEM #29314-08	<b>26.95</b>
<b>1011-3247</b>	For 95-99 Big Twin models	<b>29.95</b>
<b>1011-2960</b>	For 90-99 80" Evolution; repl. OEM #29330-96	<b>24.95</b>
<b>1011-3177</b>	For 14-17 XL models; repl. OEM #29400015	<b>26.95</b>
<b>1011-2959</b>	For 04-13 XL (except 13 1200V); repl. OEM #29331-04	<b>24.95</b>
<b>1011-2961</b>	For 88-03 XL; repl. OEM #29331-96	<b>24.95</b>

**DISCLAIMER:** NOT LEGAL FOR SALE OR USE IN CALIFORNIA ON ANY POLLUTION CONTROLLED MOTOR VEHICLES. SEE PAGE 399 FOR IMPORTANT EMISSION DEFINITIONS AND REGULATORY COMPLIANCE AND WARRANTY INFORMATION.

All part numbers in **BLUE** are new for 2017.

- WINDSHIELDS & FAIRINGS
- AUDIO & VIDEO
- SADDLEBAGS & LUGGAGE
- SEATS & SISSY BARS
- EXHAUST
- FUEL/AIR SYSTEMS
- ENGINE
- TRANSMISSION & DRIVELINE
- GASKETS & SEALS
- ELECTRICAL
- LIGHTING
- HANDLEBARS, CONTROLS & MIRRORS
- CABLES
- BRAKES
- TANKS & OIL FILTERS
- DASHES & GAUGES
- FRAMES & SUSPENSION
- FENDERS & LICENSE PLATE FRAMES
- FOOTRESTS
- WHEELS & AXLES
- HARDWARE, COVERS & GENERAL



**HIGH-FLOW REPLACEMENT AIR FILTER**

- Designed to increase horsepower and torque
- Pleated media provides a large filtration area offering long service intervals
- Application-specific sealing bead ensures an airtight fit
- Multi-layers of woven cotton gauze media offer excellent filtration
- American-made for over 45 years
- Washable, reusable, pre-oiled and ready to ride
- Made in the U.S.A.



PART #	SUG. RETAIL	PART #	SUG. RETAIL	PART #	SUG. RETAIL	PART #	SUG. RETAIL	PART #	SUG. RETAIL	PART #	SUG. RETAIL
1011-0328	\$74.95	1011-1068	\$72.95	1011-2359	\$82.95	1011-3531	\$85.95	E-3325	\$47.95	HD-2084	\$64.95
1011-0332	80.95	1011-1121	67.95	1011-2674	65.95	1011-3850	78.95	HD-0600	69.95	HD-2085X	59.95
1011-0532	86.95	1011-1289	94.95	1011-2898	89.95	BU-5000	78.95	HD-1388	92.95	HD-2086X	67.95
1011-0533	84.95	1011-1409	86.95	1011-3093	56.95	DS-289057	49.95	HD-1390	88.95	HD-8899	101.95
1011-0557	66.95	1011-1410	79.95	1011-3217	50.95	E-3224	51.95	HD-1395	94.95	RU-124	67.95
1011-1061	82.95	1011-1435	96.95	1011-3227	79.95	E-3225	51.95	HD-1396	95.95		
1011-1062	79.95	1011-1725	66.95	1011-3282	78.95	E3226	51.95	HD-1499	89.95		



**AIR FILTER ELEMENTS**

- Top-quality replacement air filter elements from Uni, the OEM supplier to Harley-Davidson
- Constructed of a unique, open-cell polyurethane material that allows maximum airflow while still providing superior filtration
- Uni elements are available for a variety of Harley applications
- Sold individually
- Made in the U.S.A.

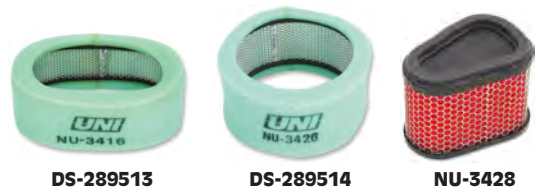

PART #	SUG. RETAIL	PART #	SUG. RETAIL	PART #	SUG. RETAIL	PART #	SUG. RETAIL	PART #	SUG. RETAIL	PART #	SUG. RETAIL
1011-0471	\$49.95	1011-1159	\$24.95	DS-289499	\$29.95	DS-289506	\$21.95	DS-289509	\$19.95	DS-289513	\$21.95
1011-0472	38.95	1011-1345	40.95	DS-289504	20.95	DS-289507	21.95	DS-289510	27.95	DS-289514	20.95
1011-0658	36.95	DS-289498	24.95	DS-289505	21.95	DS-289508	21.95	DS-289511	27.95	NU-3428	33.95

**DISCLAIMER:** NOT LEGAL FOR SALE OR USE IN CALIFORNIA ON ANY POLLUTION CONTROLLED MOTOR VEHICLES. SEE PAGE 399 FOR IMPORTANT EMISSION DEFINITIONS AND REGULATORY COMPLIANCE AND WARRANTY INFORMATION.

All part numbers in **BLUE** are new for 2017.



WINDSHIELDS & FAIRINGS

AUDIO & VIDEO

SADDLEBAGS & LUGGAGE

SEATS & SISSY BARS

EXHAUST

FUEL/AIR SYSTEMS

ENGINE

TRANSMISSION & DRIVELINE

GASKETS & SEALS

ELECTRICAL

LIGHTING

HANDLEBARS, CONTROLS & MIRRORS

CABLES

BRAKES

TANKS & OIL FILTERS

DASHES & GAUGES

FRAMES & SUSPENSION

FENDERS & LICENSE PLATE FRAMES

FOOTRESTS

WHEELS & AXLES

HARDWARE, COVERS & GENERAL

**AIR FILTER APPLICATIONS**

YEAR	MODEL	K&N #	UNI #	OEM #
<b>FOR BIG TWIN AND V-ROD</b>				
14-16	FLHT/FLHR/FLHX/FLTR/ H-D FL Trikes and 16-17 Softails (except FLSS/FLSTFBS)	<b>1011-3282</b>	-	29400045
08-13	FLHT/FLHR/FLHX/FLTR and H-D FL Trikes	<b>1011-1289</b>	-	29633-08
08-16	Dyna Glide (except 16-17 FXDLS, 13-15 FXDB)	<b>1011-1435</b>	-	29191-08
08-15	12-15 FLS, 11-13 FXS, 08-11 FLSTSB, 13-16 FXDB	<b>1011-2898</b>	-	29314-08
02-17	V-Rod	<b>1011-0332</b>	<b>1011-1345</b>	29437-01
99-15	99-06 Twin Cam (carb), 01-15 Softail (except FXS/FLS/FLSTSB), 02-07 Dresser and 04-07 Dyna Glide	<b>HD-1499</b>	-	29461-99, 29400042
99-01	88" Twin Cam Fuel-injected Dressers	<b>HD-8899</b>	-	29462-99
95-98	80" Evolution Fuel-injected	<b>HD-1395</b>	-	29291-95
95-99	80" Evolution International	<b>HD-1396</b>	-	29325-95A
93-00	80" Evolution (except Fuel-injected)	<b>HD-1390</b>	<b>DS-289499</b>	29330-96
89-92	80" Evolution	<b>HD-1390</b>	<b>DS-289511</b>	29259-89/91A
86-89	80" Evolution	<b>HD-2086X</b>	<b>DS-289507</b>	29259-86
84-85	80" Evolution (except FLT, FLHT)	<b>HD-2084</b>	<b>DS-289506</b>	29259-83A
84-85	FLT and FLHT	-	<b>DS-289508</b>	29288-83
<b>FOR XL</b>				
14-17	XL, 13 1200V	<b>1011-3227</b>	-	29400015
04-13	XL Evolution (except 13 1200V)	<b>1011-0532</b>	-	29331-04
88-03	XL	<b>HD-1388</b>	<b>DS-289510</b>	29036-88A/ 88B, 29331-96
86-87	XL	<b>HD-2085X</b>	<b>DS-289505</b>	29036-86
08-12	XR 1200/XR 1200X	<b>1011-2359</b>	-	29377-08
<b>FOR STREET</b>				
15-17	XG 500/750	<b>1011-3531</b>	-	29400078
<b>FOR BUELL</b>				
03-09	03-09 XB9/XB12/XB12S/SCG, 08 XV12SS/STT, 04-09 XB12R	<b>1011-0328</b>	<b>1011-0658</b>	P0213.0248
00-09	Blast	<b>BU-5000</b>	-	P0213.T
96-02	S1, S2, S3, M2 (except 94-95 S1, 94-98 S2/S2T, 94-96 S3/S3T)	-	<b>NU-3428</b>	29239-96Y
08-09	1125R/CR	<b>1011-1725</b>	-	P02131AMA
<b>FOR AFTERMARKET AIR CLEANERS</b>				
-	Edelbrock dual carb air filter	<b>E-3325</b>	-	-
-	Evo reverse tapered: 7" dia. (top) x 6 1/4" dia. (base) x 2 3/4" (tall)	<b>1011-1061</b>	-	-
-	Evo reverse tapered: 7" dia. (top) x 6 1/4" dia. (base) x 3 1/4" (tall)	<b>1011-1062</b>	-	-

YEAR	MODEL	K&N #	UNI #	OEM #
<b>FOR AFTERMARKET AIR CLEANERS (CONT)</b>				
-	Early Evolution Screamin' Eagle air filter (w/ lid); 7" dia. (base) x 7" dia. (top)	<b>HD-0600</b>	<b>1011-0471</b>	29055-89
-	Late Evolution Screamin' Eagle air filter (no lid)	-	<b>1011-0472</b>	-
-	Screaming Eagle stage 1 filter for 08-17 Dyna	<b>1011-1409</b>	-	29385-08
-	Screaming Eagle stage 1 filter for 08-16 FLT/FLHT/FLHR/FLHX/FLTR and 16-17 Softail	<b>1011-1410</b>	-	29242-08, 29400019
-	14-16 FLHT/FLHR/FLHX/FLTR/ H-D FL Trikes and 16-17 Softails w/58 mm SE Screamin' Eagle throttle body	<b>1011-3850</b>	-	29413-08
-	Twin Cam Screamin' Eagle tapered air filter (except 08-15 Dresser/Dyna and 16-17 Softail) (no lid); 5 1/2" dia. (top) x 6 1/4" dia. (base)	<b>1011-0557</b>	-	29244-99A/ B/C/D
-	TC Screamin' Eagle, Arlen Ness Stage II, Custom Evolution reverse tapered: 7" dia. (top) x 6" dia. (base) x 3 1/4" (tall)	<b>1011-0533</b>	-	-
-	Screamin' Eagle stage 1 for 04-16 XL (oval)	<b>1011-1068</b>	-	29044-04B/ 29400026
-	Screamin' Eagle stage 1 for 09-17 Ventilator element, 10-17 CVO Dresser (oval)	<b>1011-2674</b>	-	29670-09/ 29400022A
-	Joker Machine high-performance air cleaner assemblies	<b>1011-3217</b>	-	-
-	S&S dual-throat carb air filter	-	<b>DS-289513</b>	-
-	S&S "D" teardrop air filter; 2 1/16" (53.4mm)	<b>E-3224</b>	-	-
-	S&S Super E and G series carb air filter; 2 1/2"	<b>E3226</b>	<b>DS-289514</b>	-
-	S&S old style teardrop-shaped housing; 6" x 2 3/16" air filter	<b>E-3225</b>	<b>DS-289504</b>	-
-	6" custom air filter	-	<b>DS-289498</b>	-
-	Dragtron™ air filter	-	<b>DS-289509</b>	-
-	Dragtron™ II air filter (5.25")	<b>DS-289057</b>	<b>1011-1159</b>	-
-	Drag 7" round air filter (DS-288998)	-	<b>DS-289504</b>	-
-	Revtech PART #58-284	<b>1011-3093</b>	-	-
-	Mikuni 36-38mm dirt track air filter "D" Oval: 7" length; 10" angle; 2 1/2" flange	<b>1011-1121</b>	-	-
-	Mikuni 36-38mm dirt track air filter oval; 7" L; 10" angle; 1" flange	<b>RU-124</b>	-	-

**REPLACEMENT AIR FILTER ELEMENTS FOR STAGE 1 SCREAMIN' EAGLE® AIR CLEANER**

- Premium pre-oiled direct replacement element for Screamin' Eagle® kits
- Each is handmade one at a time in a urethane body that won't crack; four layers of surgical-grade cotton provide optimum air flow and protection
- 100% re-usable and washable
- Available in red cotton; fit with original Screamin' Eagle covers
- Can also be used with Ness Stage I top cover for an exposed filter high-performance look; no other hardware necessary



2110-9494

PART #	DESCRIPTION	SUG. RETAIL
<b>1011-2054</b>	For 08-16 FLHT/FLHR/FLHX/FLTR/H-D FL Trike and 16-17 Softail models w/ 58mm throttle body	<b>\$49.95</b>

PART #	DESCRIPTION	SUG. RETAIL
<b>2110-9494</b>	For 99-10 FXST, 02-07 FLHT, 97-07 FXD/FXDWG	<b>\$49.95</b>

**DRYCHARGERS**

- Specially designed filter wrap made to extend the service interval of your K&N air filter when used in severe dusty or wet conditions
- Made from durable polyester material containing uniform micron openings, the DryCharger® will stop small dirt particles and is water repellant, yet adds little restriction to the airflow of your filter
- Features double-stitched elastic openings to secure drycharger in place
- Designed to be run dry and can be cleaned with K&N filter cleaner
- Custom fit to each application
- Made in the U.S.A.



1011-1501

1011-3791

RU-1240PK

PART #	DESCRIPTION	SIZE	SUG. RETAIL
<b>DRYCHARGERS</b>			
<b>1011-1501</b>	For Custom Evolution reverse tapered air filter, PART #1011-0533	7" dia. (top) x 6" dia. (base) x 3 1/4" (tall)	<b>\$36.95</b>
<b>1011-1502</b>	For Twin Cam Screamin' Eagle tapered air filter (except 08-16 Dresser/Dyna), PART #1011-0557	5 1/2" dia. (top) x 6 1/4" dia. (base)	<b>\$4.95</b>
<b>1011-1502</b>	For 08-16 Touring Twin Cam Screamin' Eagle tapered air filter, PART #1011-1410	5 1/2" dia. (top) x 6 1/4" dia. (base)	<b>\$4.95</b>
<b>1011-3791</b>	For Joker Machine high-performance air cleaner assembly using air filter, PART #1011-3217	3 7/8" ID x 2"(tall)	<b>\$1.95</b>
<b>PRECHARGER</b>			
<b>RU-1240PK</b>	Precharger for Mikuni 36-38mm dirt track air filters, PART #s 1011-1121 and RU-124	3 3/4" inside width x 7" inside length (tall)	<b>\$1.95</b>

**DISCLAIMER:** NOT LEGAL FOR SALE OR USE IN CALIFORNIA ON ANY POLLUTION CONTROLLED MOTOR VEHICLES. SEE PAGE 399 FOR IMPORTANT EMISSION DEFINITIONS AND REGULATORY COMPLIANCE AND WARRANTY INFORMATION.

All part numbers in BLUE are new for 2017.