

Error Codes		
Display	Description	Cause/Correction
Ei 01	Transmission Failure	Communication failure. Re-aim external device and try again.
Ei 02	Time-out Error	Communication failure. Re-aim external device and try again.
Ei 03	Invalid Command Code	Communication successful, but the command was not valid for this machine type, or the control could not perform the command in its current mode of operation. Ensure data is for current machine type and control is in correct mode.
Ei 04	Expecting Upload Request	Communication failure. Re-aim external device and try again.
Ei 05	Invalid or Out-of-Range Data	The value in at least one of the programming options is invalid or out of range. Recheck the programming option's value and try again.
Ei 09	CRC-16 Error	Communication failure. Re-aim external device and try again.
Ei 0A	Framing Error	Communication error. Re-aim external device and try again.
Ei 0C	Time-out Exceeded	Communication error. Re-aim external device and try again.
Ei 0E	Encryption Error	Communication error. Re-aim external device and try again. If the problem persists, check that the security code is correct.
Ei 0F	Infra-red Disabled	Communication failure or infra-red is disabled. Manually enable infra-red on control or re-aim external device and try again.

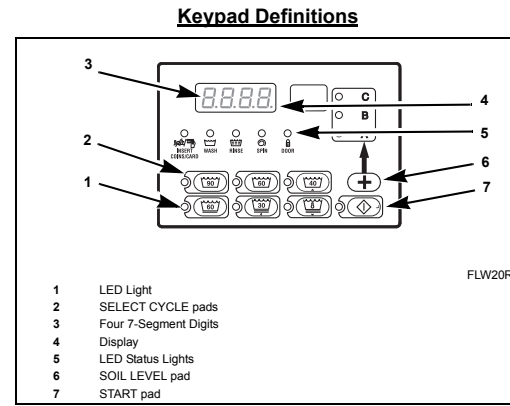

- Entering the Manual Programming Mode**
1. If the washer is in an active cycle, rapid advance through the cycle.
 2. Open the washer's service door.
 3. While pressing and holding the NORMAL 90 keypad, press the PERM PRESS 60 keypad. The display will show "r-RPd".
 4. Press the NORMAL 40 (^) or DELICATES COLD (v) keypad until "Pr-a9" is displayed.
 5. Press the START keypad. The first manual programming option, "Re5 I", is displayed.
 6. To exit, press the DELICATES 30 (<) keypad. The control will revert back to the Ready Mode.

**Frontload Washer
Pocket Programming Guide**

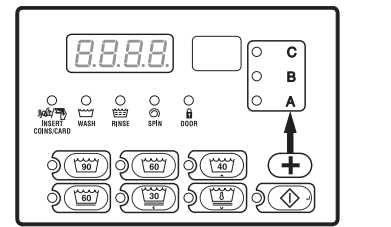

Models with an "L" in the 4th Position

Keypad Definitions
Entering the Manual Programming Mode
Error Codes
Programmable Options
Changing Vend Price

Part No. 9-09-189GR2
February 2012

© Published by permission of the copyright owner - DO NOT COPY or TRANSMIT

Error Codes		
Display	Description	Cause/Correction
EC02	Time-out Error	Communication failure. Try card again.
EC03	Invalid Command Code	Communication successful, but the command was not valid for this machine type, or the control could not perform the command in its current mode of operation. Ensure data is for current machine type and control is in correct mode.
EC05	Invalid or Out-of-Range Data	The value in at least one of the programming options is invalid or out of range. Recheck the programming option's value and try again.
EC11	No Card Reader Initialization	Communication is valid, but there is no card reader initialization. Power down, power up and try again.
EC18	No Communication	Card reader is initialized, communication lost. Power down, power up and try again. If error persists, replace control or card reader.
EC19	No Card Reader Communication	Communication failure. Power down, power up and try again. If error persists, replace control or card reader.
Right most decimal point Lit	Network Communication Error	Communication problem. Wait for 1.5 minutes for error to clear. If error doesn't clear, power-down and power-up the machine. If error persists, replace control or network board.

Error Codes		
Display	Description	Cause/Correction
RLrn	Break-in Alarm Error	Service the door or coin vault switches.
oFF	Break-in Alarm Shutdown Error	Service the door or coin vault switches.
E FL	Fill Error	Pressure switch fails to open in 30 minutes (or other programmed length of time) in any fill agitate cycle.
E 5P	SPI Communications Error	Master control cannot communicate with motor control. Caused by transformer unplugged or wiring to motor control incorrect. Power down the machine, power up and try again.
E dL	Door Lock Error	Door does not lock within 15 seconds of closing (open and reclose door) or doesn't unlock 3 minutes after cycle completion.
E da	Door Opened During A Running Cycle	Control detects door open and door locked inputs high. Caused by pulling on door while locked or about to lock. Correct inoperative door locking system.
E Ub	Unbalance Error	Unable to balance load. Redistribute load and run cycle.
E dF	Drive Failure	Motor unplugged, motor failure, tachometer circuit open or drum locked up. Unpower machine to reset.

Error Codes		
Display	Description	Cause/Correction
door	Door Open Indicator	Door is not closed during an active cycle. If door is closed, check for improper wiring or faulty door switch.
E rr	Coin Error	Invalid coin pulse or inoperative coin sensor. Check coin drop area and remove obstructions. If error persists, tampering may have occurred. Evaluate security procedures.
E oP	Open Thermistor Error	Thermistor circuit opens while heating. Heater will turn off and cycle will continue.
E SH	Shorted Thermistor Error	Thermistor circuit is shorted while heating. Heater will turn off and cycle will continue.
E HL	Heater Error	Programmed temperature hasn't been reached in more than two hours. Cycle will continue with heater off.

Changing Vend Price

1. Enter Manual Mode.
2. Press the NORMAL 40 (Λ) or the DELICATES COLD (v) keypad until "Prog" appears in the display, Press the START (enter) keypad.
3. "AS1" will appear in the display. Press the START (enter) keypad. The NORMAL 90 LED will be lit to show which cycle/temperature price is being programmed.
4. There are five digits in the Vend Price #1. The fifth digit will appear in the display and will flash one second on, one second off.

NOTE: if the vend price is 10000 or more, the fifth digit is "1-6". If the vend price is 9999 or less, the fifth digit is "0".

5. Press the NORMAL 40 (Λ) or the DELICATES COLD (v) keypad to increase or decrease the value of the fifth digit.
6. Press the START (enter) keypad to enter the fifth digit and display remaining four digits. The active digit will flash one second on and one second off.

NOTE: To go back to the current programmable option without changing the value, press the DELICATES 30 (<) keypad.

7. Press the NORMAL 40 (Λ) or the DELICATES COLD (v) keypad to increase or decrease the value of the active digit and the START (enter) keypad to enter the value of the digit and advance to the next digit.
8. Press the START (enter) keypad with the last active digit. The next option, "dE:n1", will appear in the display.
9. To exit, press the DELICATES 30 (<) keypad until the control returns to Ready Mode.

Option Number	Option Display	Description	Default	Range
1	AS1	Vend Price #1	200	0-66.535
2	dEn1	Coin #1 Value	25	1-66.535
3	dEn2	Coin #2 Value	100	1-66.535
4	PLSE	Start Pulse Value	25	1-66.535
5	PLSn	Start Pulse Mode	oFF	oFF, 128, 192
6	Avp	Available Type	0	**0-3; 0-7
7	dCYC	Default Cycle	5	1-9
8	oPL	OPL Mode	oFF	oFF
9	ALU	Audio Signal	29	0-31
10	CArd	Card Reader Display Control	oFF	oFF
11	Err	Errors	—	—
a.	CEr	Coin Error Parameters	—	—
1.	CEr1	Coin Error	on	oFF
2.	CEr2	Coin Error Penalty	oFF	oFF
3.	CEr3	Coin Drops Header Present Error	on	oFF
b.	EFL	Fill Error	on	oFF
c.	EUb	Unbalance Error	on	oFF
d.	EoP	Open Thermistor Error	on	oFF
e.	ESH	Shorted Thermistor Error	on	oFF
f.	EHT	Heater Error	on	oFF
12	CYC-	Cycle Programming	—	—
13	AS2	Vend Price #2	200	0-66.535
14	AS3	Vend Price #3	200	0-66.535
15	AS4	Vend Price #4	200	0-66.535
16	AS5	Vend Price #5	200	0-66.535
17	AS6	Vend Price #6	200	0-66.535
18	rtC-	Real Time Clock	—	—
a.	rtC1	Set Real Time Clock Minutes	—	—
b.	rtC2	Set Real Time Clock Hours	—	—
c.	rtC3	Set Real Time Clock Day	—	—
d.	rtC4	Set Real Time Clock Date	—	—
e.	rtC5	Set Real Time Clock Month	—	—
f.	rtC6	Set Real Time Clock Year	—	—
g.	rtC7	Daylight Savings Option	on	oFF
19	SPA-	Special Vend A data	—	—
a.	SA01	Special Vend A Days Enable	0	*
b.	SA02	Special Vend A Start Hour	0	0-23
c.	SA03	Special Vend A Start Minute	0	0-59
d.	SA04	Special Vend A Length in Hours	0	0-24
e.	SA05	Special Vend A Start Month	0	0-12
f.	SA06	Special Vend A Start Date	0	0-31
g.	SA07	Special Vend A Start Year	0	0-99
h.	SA08	Special Vend A End Month	0	0-12
i.	SA09	Special Vend A End Date	0	0-31
j.	SA10	Special Vend A End Year	0	0-99
k.	SA11	Special Vend A Price #1	0	0-66.535
l.	SA12	Special Vend A Price #2	0	0-66.535
m.	SA13	Special Vend A Price #3	0	0-66.535
n.	SA14	Special Vend A Price #4	0	0-66.535
o.	SA15	Special Vend A Price #5	0	0-66.535
p.	SA16	Special Vend A Price #6	0	0-66.535
q.	SA20	Special Vend A Added Wash #4 Fill/Agitate Time	0	0-15
r.	SA21	Special Vend A Subtracted Wash #4 Fill/Agitate Time	0	0-15
20	SPb-	Special Vend B Days Enable (On/Off)	oFF	oFF
21	SPc-	Special Vend C Days Enable (On/Off)	oFF	oFF
22	SPd-	Special Vend D Days Enable (On/Off)	oFF	oFF
23	CoP-	Cycle Modifier Programming	—	—
a.	CoP1	Cycle Modifier Medium Price	25	0-66.535
b.	CoP2	Cycle Modifier Heavy Price	50	0-66.535
c.	CoP3	Cycle Modifier Medium Option	2	0-15
d.	CoP4	Cycle Modifier Heavy Option	3	0-15
e.	CoP5	Cycle Modifier Added Wash Time	2	0-15
**f.	CoP6	Default Cycle Modifier	0	0-2
**24	PC-	Cycle Time Display	—	—
**a.	PC1E	Cycle Time Display Enable	oFF	oFF
**b.	PC1I	Cycle #1 Time	34	0-255
**c.	PC2	Cycle #2 Time	34	0-255
**d.	PC3	Cycle #3 Time	32	0-255
**e.	PC4	Cycle #4 Time	31	0-255
**f.	PC5	Cycle #5 Time	28	0-255
**g.	PC6	Cycle #6 Time	28	0-255
25	droP	Drop Off Mode (On/Off)	oFF	oFF
26	LFSA	Low Power/Auto Shutdown A Days Enable (On/Off)	oFF	oFF
27	LFsb	Low Power/Auto Shutdown B Days Enable (On/Off)	oFF	oFF
28	LFSC	Low Power/Auto Shutdown C Days Enable (On/Off)	oFF	oFF
29	LFSD	Low Power/Auto Shutdown D Days Enable (On/Off)	oFF	oFF
30	PFr	Power Fall Reset	oFF	oFF/133;255
31	IR	IR Access (On/Off)	on	oFF
32	rAEn	Manual Rapid Advance (On/Off)	on	oFF
33	dAEn	Manual Diagnostics (On/Off)	on	oFF
34	PIEn	Production Test Cycle (On/Off)	on	oFF

*Refer to the programming manual supplied with the machine for value definition.
**This option available in software version "S 02" or higher only.
**0-7 available in software version "S 07" or higher only.