

# Product index by series

## Cable/Spectra-Strip® quick reference guide

<b>165 Series</b> SKEWCLEAR® for External LVDS Flat Panel Displays . . . . .	1
<b>165 Series</b> SKEWCLEAR® for LVDS Channel Link™ . . . . .	2-3
<b>111 Series</b> Spectra-Bond® parallel conductors planar cable . . . . .	4-5
<b>114 Series</b> Spectra-Bond® twisted pairs planar cable . . . . .	4-5
<b>112 Series</b> Ultra-Flex® parallel conductors planar cable . . . . .	6
<b>115 Series</b> Ultra-Flex® twisted pairs planar cable . . . . .	6
<b>121 Series</b> Spectra-Coax™ planar cable . . . . .	7-8
<b>132 Series</b> Twist 'N' Flat® planar cable . . . . .	9
<b>133-2803,2804 Series</b> Qwik-Strip® ground plane planar cable . . . . .	10
<b>135 Series</b> 3C® color coded planar cable . . . . .	11
<b>141 Series</b> High Temperature PTFE Teflon* flat cable . . . . .	12-13
<b>151 Series</b> Jacketed Zip planar cable . . . . .	14-15
<b>152 Series</b> Twist 'N' Flat® jacketed cable with aluminum/poly shield . . . . .	16
<b>159-2801 Series</b> Round 'N' Flat™ jacketed shielded cable . . . . .	17
<b>159-2832 Series</b> Round Twist 'N' Flat® jacketed shielded cable . . . . .	18-19
<b>169-2832 Series</b> Loose Pair Round Twist 'N' Flat® cable . . . . .	20
<b>324-0420 Series</b> Spectra-Strip Round 'N' Flat™ Termination Press . . . . .	21-22
<b>191-2601 Series</b> Spectra-Zip® planar cable .050" center . . . . .	23
<b>191-2801 Series</b> Spectra-Zip® planar cable .050" center . . . . .	24
<b>191-2811 Series</b> Spectra-Flex™ high flex life flat cable . . . . .	25
<b>191-2815 Series</b> Spectra-Zip® 1,00 mm planar cable . . . . .	26
<b>193-2801 Series</b> TPE Insulated Zip cable .050" center . . . . .	27

\*Teflon is a trade mark of DuPont

.025" center cables . . . . .	28-39
<b>191-3X0X Series</b> Spectra-Zip® PVC .025" center . . . . .	28
<b>191-3X0X Series</b> Spectra-Zip® TPE .025" center . . . . .	29
<b>191-300X Series</b> Spectra-Strip® Ultra ATA cable . . . . .	30
<b>193-3099 Series</b> Spectra-Strip® SCA cable . . . . .	31
<b>193-3099 Series</b> Spectra-Strip® Fast 20/40 SCSI cable .025" center . . . . .	32
<b>425-3006 Series</b> .025" center Loose Pair Twist 'N' Flat® . . . . .	33
<b>125-3001 Series</b> .025" Full Lamination Twist 'N' Flat® . . . . .	34
<b>125-3007 Series</b> .025" Full Lamination Twist 'N' Flat® . . . . .	35
<b>125-3011 Series</b> .025" center Spectra-Mode™ Twist 'N' Flat® . . . . .	36
<b>133-301X Series</b> .025" center Ground Plane cable . . . . .	37
<b>151-3033 Series</b> Spectra-Zip .025" center shielded and jacketed planar cable . . . . .	38
<b>159-3003 Series</b> Spectra-Strip .025" center Round 'N' Flat™ cable . . . . .	39
Slit Cable Capabilities . . . . .	40-44
<b>491 Series</b> Spectra-Strip® Slit Zip planar cable . . . . .	41
<b>135 Series</b> Slit 3C® Color Coded Cable . . . . .	42
<b>132 Series</b> Slit Flat Twist 'N' Flat® planar cable . . . . .	43
<b>432-2802/433-2802 Series</b> Round Loose Pair Twist 'N' Flat® planar cable . . . . .	44
<b>432-2806/433-2806 Series</b> Flat Loose Pair Twist 'N' Flat® planar cable . . . . .	44
Halogen-Free Flame Retardant Cables . . . . .	45-49
<b>193-2829 Series</b> Halogen-Free Zip cable . . . . .	46
<b>132-2829 Series</b> Halogen-Free Twist 'N' Flat® planar cable . . . . .	47
<b>468-2829 Series</b> Halogen-Free Loose Pair Twist 'N' Flat® cable . . . . .	48
<b>168-2829 Series</b> Halogen-Free Loose Pair Round Twist 'N' Flat® cable . . . . .	49
technical data	
Spectra-Strip® flat cable cross reference table . . . . .	50
Copper Conductor Data . . . . .	51-53
Crosstalk . . . . .	54-55
Standard Agencies . . . . .	56-59

# SKEWCLEAR® for External LVDS Flat Panel Displays

## 165 Series



### Features/Benefits

- 9 individually shielded parallel pairs
- Round or flat options
- Non drain wire option available
- Extremely tight and consistent skew control
- Stable impedance
- High crosstalk isolation

### Applications

Dual pixel, high resolution data transmission between host and flat panel display

This is a unique SKEWCLEAR design optimized for application with National Semiconductor's FPD chipsets that enable up to 5.38 Gigabit / second copper interconnects for emerging SXGA and UXGA resolutions in flat panel displays. These chipsets take 48 bits of RGB data and transmit them

over 8 pairs. A 9th pair acts as a clock to synchronize and sample the data. Maximum cable length is 10 meters. Because of the high data pair bit rate and distances involved, precision skew control in and between cable pairs is critical for accurate clocking of the data.

### Physical

**Parallel pair conductor:** 30 awg (30 awg drain) 28 awg (28 awg drain) 26 awg (26 awg drain) 24 awg (24 awg drain) Drain wires are solid tinned copper. Signals are solid silver-plated copper.

**Insulation:** 30 awg: .012" nom polyolefin  
28 awg: .011" nom polyolefin  
26 awg: .014" nom polyolefin  
24 awg: .0175" nom polyolefin

**Pair shield:** Spiral wrapped aluminum/polyester, 20% min overlap  
**Laminate:** .003" Clear PVC, top and bottom

**Overall shield:** .001 spiral wrapped aluminized polyester, 20% min overlap, aluminum side out

**Overall shield:** 36 awg tinned copper braid. 85% min coverage

**Jacket:** Black PVC

**UL/CSA:** CL2/FT4 75° C

### Electrical

**Impedance:** 100 ohms +/- 5 ohms (Differential TDR)

**Capacitance:** 30 awg 28/26/24 awg  
51 pF/M nom 43 pF/M nom

**Propagation Delay:** 30 awg 28/26/24 awg  
5.1 ns/M 4.25 ns/M

**Skew (within pair) Max:** 98.4 ps/10M (Ref: 3 ps/ft) (TDT method, drain grounded, differential 50% - 50%, Tektronix 11801, SD-24/SD-26 sampling heads)

**Skew:** 350 ps/10M (Ref: 10.6 ps/ft) max (TDT method, drain grounded, differential 50% - 50%, Tektronix 11801, SD-24/SD-26 sampling heads)

**Near/Far End Crosstalk:** 60dB min 1 MHz to 1 GHz

**30 awg:** 5.4 dB/10M @ 140MHz  
7.0 dB/10M @ 231MHz  
9.5 dB/10M @ 420MHz  
12.5 dB/10M @ 693MHz

**28 awg:** 4.1 dB/10M @ 140MHz  
5.4 dB/10M @ 231MHz  
7.3 dB/10M @ 420MHz  
9.4 dB/10M @ 693MHz

**26 awg:** 3.3 dB/10M @ 140MHz  
4.3 dB/10M @ 231MHz  
5.8 dB/10M @ 420MHz  
7.6 dB/10M @ 693MHz

**24 awg:** 2.6 dB/10M @ 140MHz  
3.4 dB/10M @ 231MHz  
4.7 dB/10M @ 420MHz  
6.1 dB/10M @ 693MHz

### Ordering Information

#### 30 AWG

Part Number	No. Pairs	Nom OD (inches)	Nom OD (mm)
165-3099-941	9	.285	7.23

#### 28 AWG

Part Number	No. Pairs	Nom OD (inches)	Nom OD (mm)
165-2899-944	9	.285	7.23

#### 26 AWG

Part Number	No. Pairs	Nom OD (inches)	Nom OD (mm)
165-2699-961	9	.335	8.50

#### 24 AWG

Part Number	No. Pairs	Nom OD (inches)	Nom OD (mm)
165-2499-972	9	.395	10.03

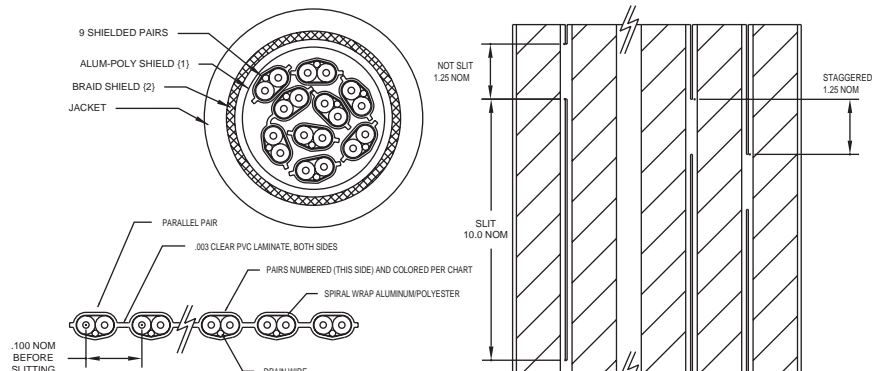

# SKEWCLEAR® for LVDS Channel Link™ 165 Series



## Features/Benefits

- Up to 50 pairs
- Round or flat options
- Non drain wire option available
- High crosstalk isolation
- Extremely tight and consistent skew control
- Stable impedance

## Applications

### PC/Computing

- Flat Panel Displays
- Monitor Link
- SCI processor interconnect
- Printer engine links
- Digital copiers
- System clustering
- Multimedia peripheral links

### Telecom/Datacom

- Switches
- Add/drop multiplexers
- Hubs
- Routers
- Digital copiers
- Box to box and rack to rack

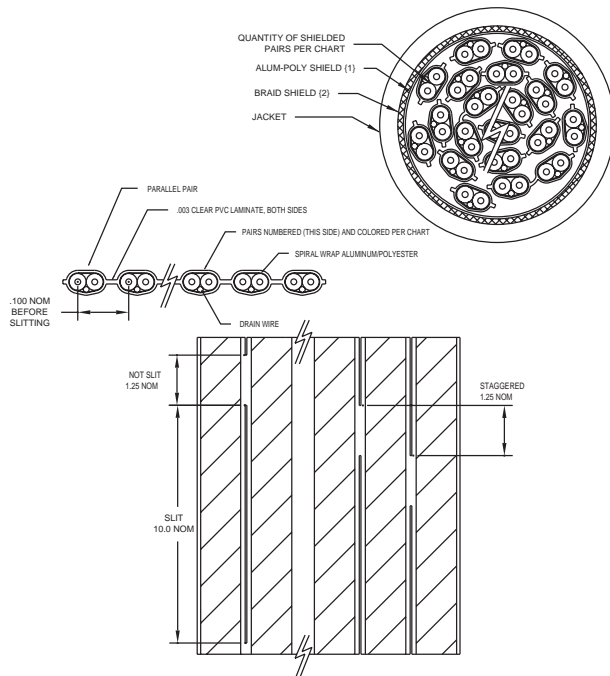

National Semiconductor's family of Channel Link low voltage differential signaling (LVDS) chipsets enable Gigabit interconnects in telecommunications and data communications applications. They are designed to provide greater bandwidth than traditional point to point technologies (such as RS232 or RS422) at a lower cost than high speed serial buses such as IEEE 1394 (Firewire) or Fibre Channel. These chipsets take 21,28, or 48 bit CMOS / TTL parallel data and serialize them onto 3, 4, or 8 data pairs. An additional

pair acts as a clock to synchronize and sample the data. Depending on clock frequency and bit width, a total data throughput of up to 5.38 Gigabits / second can be achieved over 8 data pairs. For large backplane applications where very large quantities of data are involved, multiple Channel Link chipsets can be deployed with up to 50 pairs. Because of the high data pair frequency and distances involved, precision skew control in and between cable pairs is critical for accurate clocking of the data

## Physical

**Parallel pair conductor:** 30 awg (30 awg drain) 28 awg (28 awg drain) 26 awg (26 awg drain) 24 awg (24 awg drain) Drain wires are solid tinned copper. Signals are solid silver-plated copper.

**Insulation:** 30 awg: .012" nom polyolefin  
28 awg: .011" nom polyolefin  
26 awg: .014" nom polyolefin  
24 awg: .0175" nom polyolefin

**Pair shield:** Spiral wrapped aluminum/polyester, 20% min overlap  
**Laminate:** .003" Clear PVC, top and bottom

**Overall shield:** .001 spiral wrapped aluminized polyester, 20% min overlap, aluminum side out

**Overall shield:** 36 awg tinned copper braid. 85% min coverage  
**Jacket:** Black PVC

**UL/CSA:** CL2/FT4 75° C

## Electrical

**Impedance:** 100 ohms +/- 5 ohms (Differential TDR)

**Capacitance:**

30 awg	28/26/24 awg
51 pF/M nom	43 pF/M nom

**Propagation Delay:**

30 awg	28/26/24 awg
5.1 ns/M	4.25 ns/M

**Skew (within pair) Max:** 98.4 ps/10M (Ref: 3 ps/ft) (TDT method, drain grounded, differential 50% - 50%, Tektronix 11801, SD-24/SD-26 sampling heads)

**Skew:** 350 ps/10M (Ref: 10.6 ps/ft) max (TDT method, drain grounded, differential 50% - 50%, Tektronix 11801, SD-24/SD-26 sampling heads)

**Near/Far End Crosstalk:** 60dB min 1 MHz to 1 GHz

**Attenuation (nom):**

**30 awg:**  
5.4 dB/10M @ 140MHz  
7.0 dB/10M @ 231MHz  
9.5 dB/10M @ 420MHz  
12.5 dB/10M @ 693MHz

**28 awg:**  
4.1 dB/10M @ 140MHz  
5.4 dB/10M @ 231MHz  
7.3 dB/10M @ 420MHz  
9.4 dB/10M @ 693MHz

**26 awg:**  
3.3 dB/10M @ 140MHz  
4.3 dB/10M @ 231MHz  
5.8 dB/10M @ 420MHz  
7.6 dB/10M @ 693MHz

**24 awg:**  
2.6 dB/10M @ 140MHz  
3.4 dB/10M @ 231MHz  
4.7 dB/10M @ 420MHz  
6.1 dB/10M @ 693MHz



## 30 AWG

Part Number	No. Pairs	Nom OD (inches)	Nom OD (mm)
165-3099-938	4	.215	5.46
165-3099-939	5	.230	5.84
165-3099-940	8	.275	6.98
165-3099-941	9	.285	7.23
165-3099-942	10	.295	7.40
165-3099-943	15	.345	8.76
165-3099-944	20	.385	9.77
165-3099-945	25	.435	11.04
165-3099-946	30	.475	12.06
165-3099-947	35	.505	12.82
165-3099-948	40	.535	13.58
165-3099-949	50	.585	14.85

## 28 AWG

Part Number	No. Pairs	Nom OD (inches)	Nom OD (mm)
165-2899-941	4	.215	5.46
165-2899-942	5	.235	5.97
165-2899-943	8	.275	6.99
165-2899-944	9	.285	7.24
165-2899-945	10	.300	7.62
165-2899-946	15	.350	8.89
165-2899-947	20	.390	9.91
165-2899-948	25	.435	11.05
165-2899-949	30	.480	12.19
165-2899-950	35	.510	12.94
165-2899-951	40	.540	13.72
165-2899-952	50	.590	14.99

## 26 AWG

Part Number	No. Pairs	Nom OD (inches)	Nom OD (mm)
165-2699-958	4	.250	6.35
165-2699-959	5	.270	6.85
165-2699-960	8	.320	8.12
165-2699-961	9	.335	8.50
165-2699-962	10	.350	8.89
165-2699-963	15	.420	10.66
165-2699-964	20	.480	12.19
165-2699-965	25	.530	11.04
165-2699-966	30	.570	14.47
165-2699-967	35	.610	15.49
165-2699-968	40	.640	16.25
165-2699-969	50	.710	18.03

## 24 AWG

Part Number	No. Pairs	Nom OD (inches)	Nom OD (mm)
165-2499-969	4	.290	7.36
165-2499-970	5	.315	8.00
165-2499-971	8	.380	9.65
165-2499-972	9	.395	10.03
165-2499-973	10	.425	10.79
165-2499-974	15	.510	12.95
165-2499-975	20	.575	14.60
165-2499-976	25	.630	16.00
165-2499-977	30	.685	16.51
165-2499-978	35	.730	18.54
165-2499-979	40	.795	20.19
165-2499-980	50	.875	22.22

# Spectra-Bond® parallel conductors — 111 series and Spectra-Bond® twisted pairs — 114 series

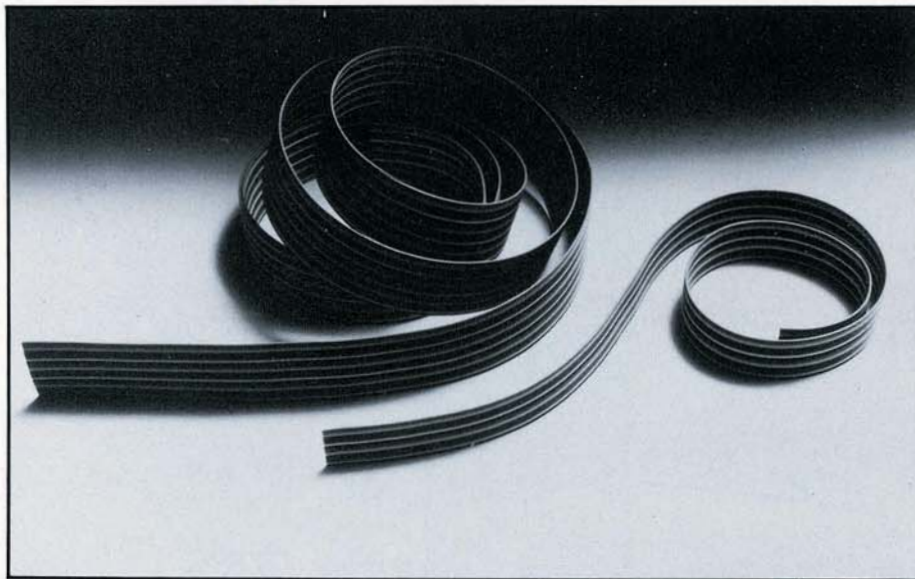

## benefits

- Low cost point-to-point wiring
- Insulation easily separated for circuit routing
- Color coded
- Standard termination techniques
- Versatile applications
- UL recognized style 

## characteristics

### Physical

#### — 111 series — parallel

Conductors: 22-30 AWG, 7 and 19 strand, tinned copper

Insulation: .010" nom. wall, flame retardant PVC

Number of conductors: 2 to 100

Color code: brown, red, orange, yellow, green, blue, violet, gray, white, black (repeat)

#### — 114 series — twisted pairs

Conductors: 22-30 AWG, 7 strand, tinned copper

Insulation: .010" nom. wall, flame retardant PVC, .016" nom. wall, flame retardant PVC available

Number of conductors: 2 to 100

### Electrical

Voltage rating: 300 V per UL

Insulation resistance:  
10<sup>10</sup> ohms — 10 ft., min.

UL style number: Cable style 2697, cable style 2693

Temperature rating: 2697 (80°C, 300V), 2693 (105°C, 300V)

CSA: Available upon request

## description

Bonded planar cable was originally developed, patented and introduced by Spectra-Strip. Bonded flat ribbon cables reduce both cost and packaging volume because they can be contour-formed, are self-supporting with minimum clamping, and can dissipate heat faster than round multi-conductor cable. They are used today in a great variety of interconnective systems using point-to-point wiring applications. These flat cables are fully compatible with standard termination techniques such as soldering, crimping and wire wrapping.

Spectra-Strip standard bonded cable consists of stranded or solid round conductors insulated with color-coded PVC and bonded together by a patented process to form a flat ribbon.

## special bonded cables

Spectra-Strip has a highly versatile design and manufacturing capability for planar bonded PVC cables. A wide range of specially designed and produced constructions can be obtained by consulting the factory with specific requirements and cable descriptions.

Bonded constructions may be designed so that a single cable can contain several different wires or cables to provide a complete range of circuit functions including power, control, transmission and signalling.

A special cross-linked PVC insulation offering improved performance in resistance to heat and abrasion plus outstanding flame retardancy is also available. It is produced by exposure to a high-energy electron beam which cross-links the molecular structure of the PVC.

## dimensions

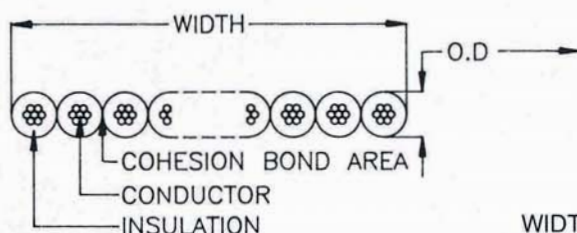

30 AWG	=	.032"	(0.81 mm)
28 AWG	=	.035"	(0.89 mm)
26 AWG	=	.039"	(1.00 mm)
24 AWG	=	.044"	(1.12 mm)
22 AWG	=	.051"	(1.30 mm)

$$\text{WIDTH} = (\text{Number of Conductors}) \times (\text{O.D.})$$



# Spectra-Bond® parallel conductors and Spectra-Bond® twisted pairs

## order information

— 111 series

Part No.	AWG	No. Cond.	STR	Nom. Width 'W'		Approx. Wt./Roll	
				in.	(mm)	lbs.	(kg)
843-111-3003-010	30	10	7/38	.32	(8,13)	.74	(0,34)
843-111-3003-015	30	15	7/38	.48	(12,19)	1.11	(0,50)
843-111-3003-020	30	20	7/38	.64	(16,26)	1.48	(0,67)
843-111-3003-030	30	30	7/38	.96	(24,38)	2.22	(1,01)
843-111-2803-010	28	10	7/36	.35	(8,89)	1.00	(0,45)
843-111-2803-015	28	15	7/36	.53	(13,34)	1.50	(0,68)
843-111-2803-020	28	20	7/36	.70	(17,78)	2.00	(0,91)
843-111-2803-030	28	30	7/36	1.05	(26,67)	3.00	(1,36)
843-111-2609-010	26	10	7/34	.39	(9,91)	1.42	(0,64)
843-111-2609-014	26	14	7/34	.55	(13,88)	1.99	(0,90)
843-111-2609-015	26	15	7/34	.59	(14,86)	2.13	(0,97)
843-111-2609-016	26	16	7/34	.63	(15,88)	3.18	(1,44)
843-111-2609-020	26	20	7/34	.78	(19,81)	2.84	(1,29)
843-111-2609-030	26	30	7/34	1.17	(29,72)	4.26	(1,93)
843-111-2413-010	24	10	7/32	.44	(11,18)	2.05	(0,93)
843-111-2414-010	24	10	19/36	.45	(11,43)	2.22	(1,01)
843-111-2413-015	24	15	7/32	.66	(16,76)	3.08	(1,40)
843-111-2414-015	24	15	19/36	.68	(17,15)	3.33	(1,51)
843-111-2413-020	24	20	7/32	.88	(22,35)	4.10	(1,86)
843-111-2414-020	24	20	19/36	.90	(22,86)	4.44	(2,01)
843-111-2413-030	24	30	7/32	1.32	(33,53)	6.15	(2,79)
843-111-2414-030	24	30	19/36	1.35	(34,29)	6.66	(3,02)
843-111-2213-010	22	10	7/30	.51	(12,94)	2.97	(1,35)
843-111-2214-010	22	10	19/34	.51	(12,94)	3.22	(1,46)
843-111-2213-015	22	15	7/30	.77	(19,43)	4.46	(2,02)
843-111-2214-015	22	15	19/34	.77	(19,43)	4.83	(2,19)
843-111-2213-020	22	20	7/30	1.02	(25,91)	5.94	(2,69)
843-111-2214-020	22	20	19/34	1.02	(25,91)	6.44	(2,92)
843-111-2213-030	22	30	7/30	1.53	(38,86)	8.91	(4,04)
843-111-2214-030	22	30	19/34	1.53	(38,86)	9.66	(4,38)

Standard sizes are stocked and packaged in 100 foot put-ups.

## order information

— 114 series

Please consult factory for full information.

80°C, 300V cable may be certified under Canadian Standards Association (CSA) Appliances Wiring Material Program, (specify UL Style or CSA at time of order). For different wire gauges, number of conductors, color striping, materials and other special requirements, please consult the factory.



# Ultra-Flex<sup>®</sup> parallel conductors Ultra-Flex<sup>®</sup> twisted pairs — 112, 115 series

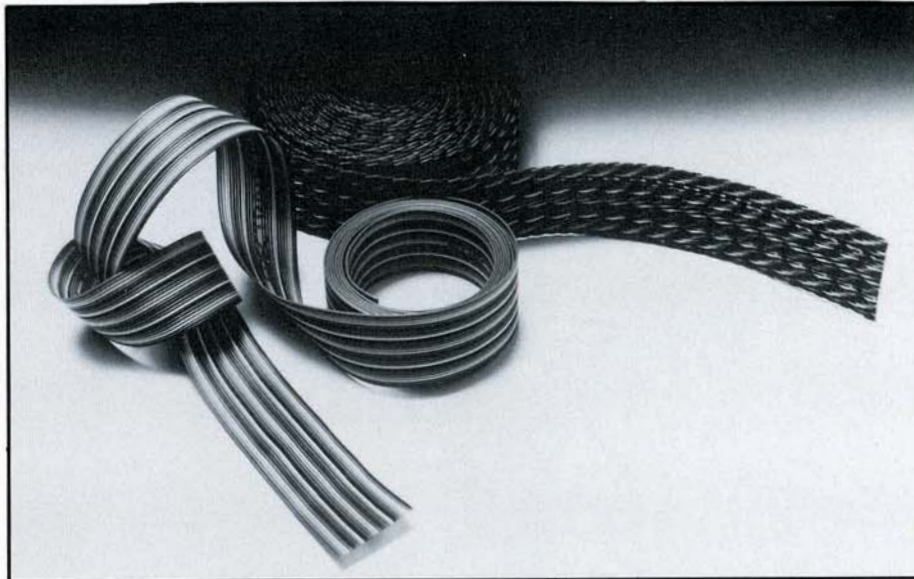

## benefits

- Highly flexible for continuous flexing operations
- Low-cost point-to-point wiring
- Easily separated for breakouts
- Contour formed
- Color coded
- UL recognized style 

## characteristics

### Physical

#### — 112 series — parallel

Conductors: 16-30 AWG, 26 to 105 strands, bare or tinned copper  
Insulation: .010", .016" nom. wall, flame retardant PVC  
Number of conductors: 2-100  
Flexibility: Continuous without damage to electrical, mechanical or physical properties

#### — 115 series — twisted pairs

Conductors: 16-30 AWG 26 to 105 strands, bare or tinned copper  
Bare or tinned copper  
Insulation: .010", .016" nom. wall flame retardant PVC  
Number of conductors: 2-100

### Electrical

Voltage rating: 300V per UL  
UL style number: Cable Style 2697, Cable Style 2693  
Temperature rating: 2697: 80°C (+ 176°F) 300V; 2693: 105°C (+ 221°F) 300V  
Insulation resistance: 10<sup>10</sup> ohms 10 ft.  
CSA: Available upon request

## dimensions

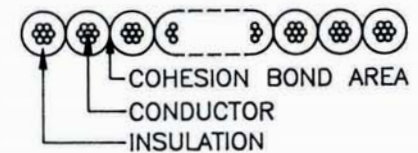

112 series

## order information

Please consult factory for full information.

## description

Spectra-Strip Ultra-Flex bonded planar cable is designed with great flexibility to meet applications which call for frequent or constant flexing without damage or alteration to electrical, mechanical or physical properties. Along with the Spectra-Bond cable, which was originally developed, patented and introduced by Spectra-Strip, Ultra-Flex is used in a great many interconnection applications with point-to-point wiring. It has the same advantages as Spectra-Bond cable — excellent bonding, separation, breakouts and termination techniques. These cables reduce both cost and packaging volume because they can be contour-formed, self-supporting with a minimum of clamping and can dissipate heat faster than round multi-conductor cable.

Standard Ultra-Flex bonded cables consist of stranded, round conductors insulated with color-coded PVC bonded together by a patented process to form a flat ribbon.

A wide range of specially designed constructions are also available, including special striping and color coding, plus an intermix of wire sizes. Consult the factory with your particular needs.

## cable selection chart

AWG	Stranding	Copper Type	Insulation Thickness	Nominal OD/IN	Number of Conductors
30	26/44	Bare	B	.035 (0,89)	2-100
			C	.046 (1,17)	
26	64/44	Bare	C	.051 (1,30)	2-100
24	105/44	Bare	B	.049 (1,24)	2-87
			C	.056 (1,42)	
22	105/42	Tinned	B	.052 (1,32)	2-80
			C	.062 (1,57)	
20	105/40	Tinned	C	.072 (1,83)	2-73
18	105/38	Tinned	C	.086 (2,18)	2-62
16	105/36	Tinned	C	.096 (2,44)	2-56

B = wall thickness .010" nominal  
C = wall thickness .016" nominal



# Spectra-Coax™ planar cable — 121 series



## description

Spectra-Coax planar cable is the cable with high signal speed that can be mass terminated. Used in high-speed computers and other digital equipment, coax planar cable combines economy of time and money through reliability, space and labor savings.

Manufactured with controlled centers, Spectra-Coax cable consists of individual solid conductors, each with foamed or solid polypropylene insulation, a foil shield, and a drain wire. An extruded, contoured outer jacket allows mass termination or separation and stripping of conductors. This standard flat cable can be cut to any length and still maintain controlled centers.

Spectra-Strip can also custom design a coax planar cable for your exact needs. For other gauges, spacing and materials, please consult the Spectra-Strip factory.

## order information

Series 121-3001 — 93 Ohm

Part Number	No. Conds.	Width "A"		Width "B"	
		Inch	(mm)	Inch	(mm)
843-121-3001-002	2	0.200	(05,08)	0.100	(02,54)
843-121-3001-003	3	0.300	(07,62)	0.200	(05,08)
843-121-3001-004	4	0.400	(10,16)	0.300	(07,62)
843-121-3001-005	5	0.500	(12,70)	0.400	(10,16)
843-121-3001-006	6	0.600	(15,24)	0.500	(12,70)
843-121-3001-007	7	0.700	(17,78)	0.600	(15,24)
843-121-3001-008	8	0.800	(20,32)	0.700	(17,78)
843-121-3001-009	9	0.900	(22,86)	0.800	(20,32)
843-121-3001-010	10	1.000	(25,40)	0.900	(22,86)
843-121-3001-013	13	1.300	(33,02)	1.200	(30,48)
843-121-3001-017	17	1.700	(43,18)	1.600	(40,64)
843-121-3001-020	20	2.000	(50,80)	1.900	(48,26)
843-121-3001-025	25	2.500	(63,50)	2.400	(60,96)
843-121-3001-030	30	3.000	(76,20)	2.900	(73,66)
843-121-3001-033	33	3.300	(83,82)	3.200	(81,28)

## benefits

- High signal speed
- Controlled impedance
- Up to 33 conductors, with precise spacing for controlled electrical characteristics
- Mass termination
- Conductor separation and stripping
- UL recognized style

## characteristics

121-3001-0XX (93 Ohm)

### Physical

Center conductor: 30 AWG copper, enamel coated (tinned coated available upon request)  
 Dielectric: Foamed polypropylene  
 Diameter: .064" ± .002"  
 Drain Wire: 28 AWG tinned copper  
 Shield: Aluminum poly foil  
 Jacket: Red PVC, .017" wall  
 Conductor spacing: .100" ± .009"  
 Cable thickness: .100" nom.

### Electrical

UL style: 2741  
 Impedance: 93 ± 5 ohms  
 Capacitance: 14 ± 2 pf/ft. nom.  
 Crosstalk: <.1% NE and FE  
 unbalanced, 10-foot cable length  
 Risetimes: 3,5 or 7 nanosec.  
 Propagation delay: 1.35 nanosec./ft.  
 Velocity of propagation: 78%  
 Risetime degradation: <350 pico-sec/10 ft. (20-80%)  
 Attenuation: 6 db/100 ft. nom. (100 MHz)

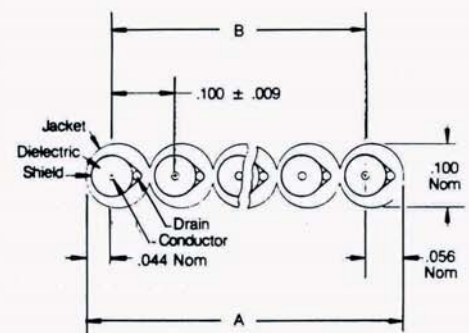



# Spectra-Coax™ planar cable — 121 series

## characteristics

121-3002-0XX (75 Ohm)

### Physical

Center conductor: 30 AWG copper, enamel coated (tinned coated available upon request)  
Dielectric: Foamed polypropylene  
Diameter: .047" ± .002"  
Drain Wire: 28 AWG tinned copper  
Shield: Aluminum poly foil  
Jacket: Gray PVC, .025" wall  
Conductor spacing: .100" ± .009"  
Cable thickness: .100" nom.

### Electrical

UL style: 2741  
Impedance: 75 ± 4 ohms  
Capacitance: 17.1 ± 1 pf/ft.  
Crosstalk: <.1% NE and FE unbalanced, 10-foot cable length  
Risetimes: 3, 5 or 7 nanosec.  
Propagation delay: 1.35 nanosec./ft.  
Velocity of propagation: 78%  
Risetime degradation: <350 picosec./10 ft. (20-80%)  
Attenuation: 7.3 db/100 ft. nom. (100 MHz)

## characteristics

121-2803-0XX (50 Ohm)

### Physical

Center conductor: 28 AWG copper, enamel coated (tinned coated available upon request)  
Dielectric: Solid polypropylene  
Diameter: .041" ± .002"  
Drain wire: 28 AWG tinned copper  
Shield: Aluminum poly foil  
Jacket: Black PVC, .028" wall  
Conductor spacing: .100" ± .009"  
Cable thickness: .100" nom.

### Electrical

UL style: 2741  
Impedance: 50 ± 3 ohms  
Capacitance: 31 ± 1 pf/ft.  
Crosstalk: <.1% NE and FE unbalanced, 10-foot cable length  
Risetimes: 3,5 or 7 nanosec.  
Propagation delay: 1.54 nanosec./ft.  
Velocity of propagation: 66%  
Risetime degradation: <400 picosec./10 ft. (20-80%)  
Attenuation: 11 db/100 ft. nom. (100 MHz)

## order information

Series 121-3002 — 75 Ohm

Part Number	No. Conds.	Width "A"		Width "B"	
		Inch	(mm)	Inch	(mm)
843-121-3002-002	2	0.200	(05,08)	0.100	(02,54)
843-121-3002-003	3	0.300	(07,62)	0.200	(05,08)
843-121-3002-004	4	0.400	(10,16)	0.300	(07,62)
843-121-3002-005	5	0.500	(12,70)	0.400	(10,16)
843-121-3002-006	6	0.600	(15,24)	0.500	(12,70)
843-121-3002-007	7	0.700	(17,78)	0.600	(15,24)
843-121-3002-008	8	0.800	(20,32)	0.700	(17,78)
843-121-3002-009	9	0.900	(22,86)	0.800	(20,32)
843-121-3002-010	10	1.000	(25,40)	0.900	(22,86)
843-121-3002-013	13	1.300	(33,02)	1.200	(30,48)
843-121-3002-017	17	1.700	(43,18)	1.600	(40,64)
843-121-3002-020	20	2.000	(50,80)	1.900	(48,26)
843-121-3002-025	25	2.500	(63,50)	2.400	(60,96)
843-121-3002-030	30	3.000	(76,20)	2.900	(73,66)
843-121-3002-033	33	3.300	(83,82)	3.200	(81,28)

## order information

Series 121-2803 — 50 Ohm

Part Number	No. Conds.	Width "A"		Width "B"	
		Inch	(mm)	Inch	(mm)
843-121-2803-002	2	0.200	(05,08)	0.100	(02,54)
843-121-2803-003	3	0.300	(07,62)	0.200	(05,08)
843-121-2803-004	4	0.400	(10,16)	0.300	(07,62)
843-121-2803-005	5	0.500	(12,70)	0.400	(10,16)
843-121-2803-006	6	0.600	(15,24)	0.500	(12,70)
843-121-2803-007	7	0.700	(17,78)	0.600	(15,24)
843-121-2803-008	8	0.800	(20,32)	0.700	(17,78)
843-121-2803-009	9	0.900	(22,86)	0.800	(20,32)
843-121-2803-010	10	1.000	(25,40)	0.900	(22,86)
843-121-2803-013	13	1.300	(33,02)	1.200	(30,48)
843-121-2803-017	17	1.700	(43,18)	1.600	(40,64)
843-121-2803-020	20	2.000	(50,80)	1.900	(48,26)
843-121-2803-025	25	2.500	(63,50)	2.400	(60,96)
843-121-2803-030	30	3.000	(76,20)	2.900	(73,66)
843-121-2803-033	33	3.300	(83,82)	3.200	(81,28)



# Twist 'N' Flat® planar cable — 132 series



## benefits

- Unique design allows mass termination to IDC connectors.
- Up to 64 conductors (32 pairs) with precise spacing for controlled electrical characteristics.
- Highly flexible PVC insulation, color coded.
- Double contour at flat sections allows termination from either side of cable.
- Easy conductor separation for circuit routing.
- UL recognized 
- CSA certified, available

## description

Spectra-Strip Twist 'N' Flat cable combines the time and cost savings of mass termination with the electrical performance of twisted pairs, making it ideal for high speed computers and communications equipment. Labor savings of up to 95% as compared to automatic strip and crimp termination are readily achieved.

Twist 'N' Flat cable consists of stranded round conductors insulated with color-coded PVC, twisted into pairs and laminated between layers of PVC film to form a planar cable. The twist in adjacent pairs is reversed to reduce cable crosstalk even further. Standard cables alternate 18-inch (45,7 cm) long twisted pair sections with 2 inch (5,1 cm) flat sections in which the conductors are laminated in parallel. Twist 'N' Flat cable is packaged in 100-foot putups in dispenser boxes.

Twist 'N' Flat cable can also be fabricated to your custom requirements. Flat sections can be made longer to allow room for multiple connectors. Twisted pair length can be varied from a minimum of 6 inches to many feet to conform with your requirements. The lamination can be fabricated "loose" at specified points to provide easy access to individual conductors. For complete details, consult the Spectra-Strip factory nearest you.

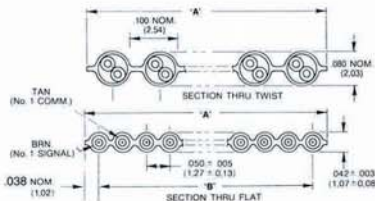
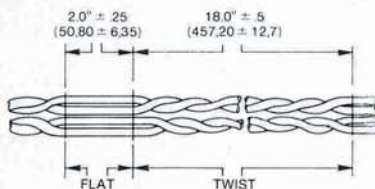

## order information

Series 843-132-2801 28 AWG, 7/36 .050" centers

Part Number	No. Pairs	Width 'A'		Span "B"	
		Inch	(mm)	Inch	(mm)
843-132-2801-010	5	.526	(13,36)	.450 ± .015	(11,43 ± 0,38)
843-132-2801-014	7	.726	(18,44)	.650 ± .015	(16,51 ± 0,38)
843-132-2801-016	8	.826	(20,98)	.750 ± .015	(19,05 ± 0,38)
843-132-2801-020	10	1.026	(26,06)	.950 ± .015	(24,13 ± 0,38)
843-132-2801-026	13	1.326	(33,68)	1.250 ± .015	(31,75 ± 0,38)
843-132-2801-034	17	1.726	(43,84)	1.650 ± .015	(41,91 ± 0,38)
843-132-2801-036	18	1.826	(46,38)	1.750 ± .015	(44,45 ± 0,38)
843-132-2801-040	20	2.026	(51,46)	1.950 ± .020	(49,53 ± 0,51)
843-132-2801-050	25	2.526	(64,16)	2.450 ± .020	(62,23 ± 0,51)
843-132-2801-060	30	3.026	(76,86)	2.950 ± .020	(74,93 ± 0,51)
843-132-2801-064	32	3.226	(81,94)	3.150 ± .025	(80,01 ± 0,64)

## characteristics

### Physical

Conductors: 28 AWG, 7/36 strand, tinned copper  
 Conductor insulation: .010" nom. wall  
 Number of conductors: 10, 14, 16, 20, 26, 34, 36, 40, 50, 60 and 64  
 Color code: Brown, red, orange, yellow, green, blue, violet, gray, white, black (repeat) tan common  
 Conductor spacing: Twisted pair centers: .100" nom.; conductor centers in flats: .050" ± .005"  
 Cable thickness: .042" ± .003" (flat section)  
 Laminate: Clear PVC, self-extinguishing

### Electrical

Voltage rating: 300 V  
 Current rating: 1 amp nom. at 10°C above ambient  
 Temperature rating: 80°C  
 Impedance: 100 ohms nom.  
 Capacitance: 15 pf/ft. (49 pf/m) nom.  
 Crosstalk: 10' sample, 5 ns rise time.  
 Unbalanced (2 lines driven): NE = 4.0%, FE = 3.5% nominal. Balanced line: NE = .7%, FE = .45%  
 Propagation delay: 1.6 ns/ft. (5.2 ns/m) nom.  
 Insulation resistance: 10<sup>10</sup> ohms 10 ft. (3 m) min.  
 UL style number: Cable style 2697 (80°C), Cable style 20130 (105°C), Component wire style 1061 or 1731.  
 CSA: Cable may be certified under Canadian Standard Association (CSA) Appliance Wiring Material Program (Specify at time of order); CSA AWM I A80°C, 300 V, FT-1.

## other capabilities

Twist 'N' Flat cable is available in the following gauges and spacings: consult factory.

Centers	AWG (Wire Size)
.050"	30, 28, 26, solid and stranded
.0625"	30, 28, 26, solid and stranded

Consult factory for special Twist 'N' Flat length capabilities.



# Qwik Strip® ground plane planar cable — 133-2803, 2804 series

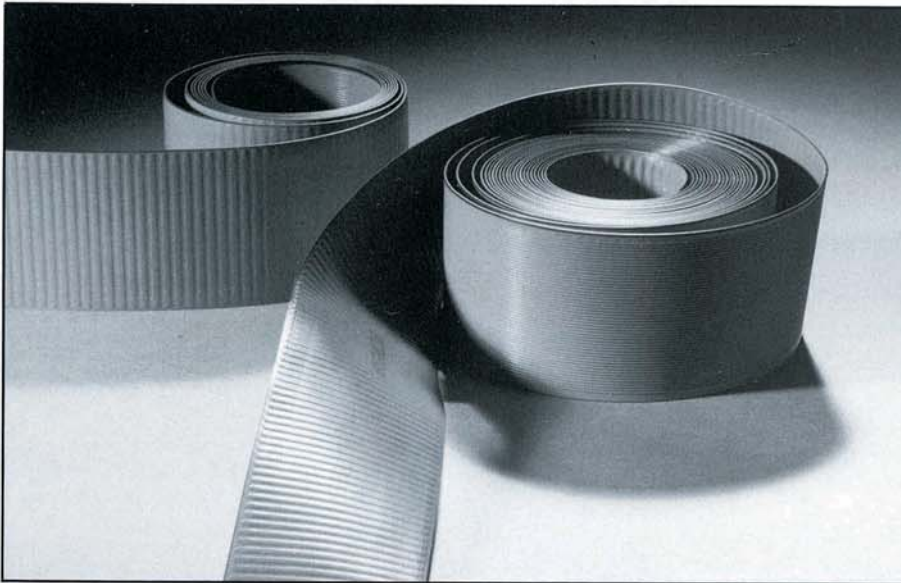

## benefits

- Quick easy cable preparation
- Cost savings in termination labor
- Consistent peel back
- Proven design for controlling both crosstalk and EMI/RFI
- UL recognized style
- CSA available

## characteristics

### Physical

Conductors and drain wire: 28 AWG, 7/36 strand, tinned copper  
 Ground plane: .005" (0,13mm) expanded copper mesh  
 Number of conductors: 20, 26, 34, 40, 50, 60  
 Conductor spacing: .050" ± .002" (1,27 ± 0,05)  
 Laminate: Gray PVC, flame retardant  
 Edge marking: 2803 series (with drain wire) black edge.  
 2804 series (without drain wire) red edge.  
 Cable thickness: .055" (1,40mm) nom.

### Electrical

Voltage rating: 300 V  
 Current rating: 1 amp nom. at 10°C above ambient  
 Temperature rating: 105°C (221°F)  
 \*Impedance: 65 ohms nominal  
 \*Capacitance: 29 pf/ft. (95 pf/m) nominal @ 1MHz  
 Propagation delay: 1.65 ns/ft. (5.2 ns/m) nominal  
 Crosstalk: 10' sample: 5 ns rise time with 2 lines driven  
 NE = 1.2%, FE = 3.5%  
 Insulation resistance: 10<sup>10</sup> ohms — 10 ft.  
 UL style number: Cable style 2682  
 \*Measured from conductor to ground plane.

## description

Take the work out of ground-plane cable preparation. No more time-consuming and messy, abrasive stripping equipment. Just notch or cut edge to length of strip needed, then use your fingers to peel back the lamination. The labor savings are enormous.

Qwik-Strip cable, while still keeping the proven design for controlling both crosstalk and EMI/RFI, is ideal for inter-connection applications. It is particularly well suited for computer and communications equipment that use high-speed techniques for switching and data transmission.

## order information

Series 133-2803 with drain wire (black edge)

Part Number	No. Cond.	Width 'A'		Span 'B'	
		In.	(mm)	In.	(mm)
843-133-2803-020	20	1.250	(31,75)	0.950±010	(24,13)
843-133-2803-026	26	1.550	(39,37)	1.250±010	(31,75)
843-133-2803-034	34	1.950	(49,53)	1.650±010	(41,91)
843-133-2803-040	40	2.250	(57,15)	1.950±010	(49,53)
843-133-2803-050	50	2.750	(69,85)	2.450±010	(62,23)
843-133-2803-060	60	3.250	(82,55)	2.950±010	(74,93)

Series 133-2804 without drain wire (red edge)

Part Number	No. Cond.	Width 'A'		Span 'B'	
		In.	(mm)	In.	(mm)
843-133-2804-020	20	1.250	(31,75)	0.950±010	(24,13)
843-133-2804-026	26	1.550	(39,37)	1.250±010	(31,75)
843-133-2804-034	34	1.950	(49,53)	1.650±010	(41,91)
843-133-2804-040	40	2.250	(57,15)	1.950±010	(49,53)
843-133-2804-050	50	2.750	(69,85)	2.450±010	(62,23)
843-133-2804-060	60	3.250	(82,55)	2.950±010	(74,93)

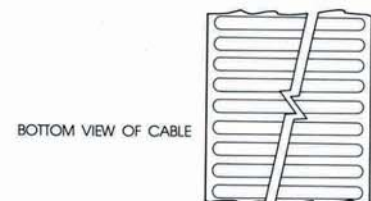
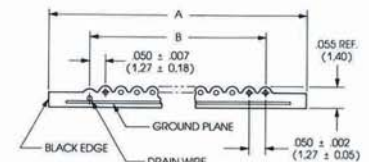



# 3C<sup>®</sup> color coded planar cable — 135 series

- Fast, low-cost mass termination.
- Precise spacing for controlled electrical characteristics.
- Color coded for easy identification.
- Double contour allows termination from either side of cable.
- Easy conductor separation for circuit routing.
- UL recognized 
- CSA certified, available

## description

3C Controlled Characteristics Cable is ideal for applications in digital and analog signal transmission. 3C color-coded cables are designed for mass-termination techniques including Spectra-Strip IDC connectors. With conductor centers the same as the contact centers of the connector, separation and stripping of individual conductors is completely eliminated. The color coding allows easy circuit tracing and routing.

Spectra-Strip 3C color-coded cable consists of stranded round conductors preinsulated with color-coded PVC and laminated on specific centers between layers of clear PVC film to form a planar cable. 3C cable is available in 100-foot putups, packaged in dispenser boxes.

Spectra-Strip has the ability to custom design a ribbon cable for your exact needs. We can provide you with exact electrical and mechanical characteristics by varying the conductor spacing and cable insulation. For custom designs, please consult the Spectra-Strip factory.

## order information

Series 843-135-2801 28 AWG, 7/36 .050" centers

Part Number	No. Cond.	Width 'A'		Span 'B'	
		Inches	(mm)	Inches	(mm)
843-135-2801-010	10	.505	(12,83)	.450±.015	(11,43±0,38)
843-135-2801-014	14	.705	(17,91)	.650±.015	(16,51±0,38)
843-135-2801-016	16	.805	(20,45)	.750±.015	(19,05±0,38)
843-135-2801-020	20	1.005	(25,53)	.950±.015	(24,13±0,38)
843-135-2801-024	24	1.205	(30,61)	1.150±.015	(29,21±0,38)
843-135-2801-025	25	1.255	(31,88)	1.200±.015	(30,48±0,38)
843-135-2801-026	26	1.305	(33,15)	1.250±.015	(31,75±0,38)
843-135-2801-034	34	1.705	(43,31)	1.650±.015	(41,91±0,38)
843-135-2801-036	36	1.805	(45,85)	1.750±.015	(44,45±0,38)
843-135-2801-037	37	1.855	(47,12)	1.800±.015	(45,72±0,38)
843-135-2801-040	40	2.005	(50,93)	1.950±.020	(49,53±0,51)
843-135-2801-050	50	2.505	(63,63)	2.450±.020	(62,23±0,51)
843-135-2801-060	60	3.005	(76,33)	2.950±.020	(74,93±0,51)
843-135-2801-064	64	3.205	(81,41)	3.205±.020	(80,01±0,51)

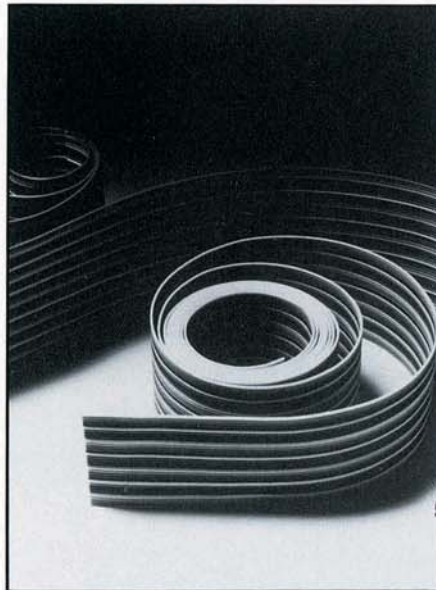

## characteristics

### Physical

Conductors: 28 AWG, 7/36 strand, tinned copper  
 Number of conductors: 10, 14, 16, 20, 24, 25, 26, 34, 36, 37, 40, 50, 60 and 64  
 Color code: Brown, red, orange, yellow, green, blue, violet, gray, white, black (repeat)  
 Conductor spacing: .050" ± .005"  
 Cable thickness: .042" ± .003"  
 Laminate: Clear PVC, self-extinguishing

## Electrical

Voltage rating: 300 V  
 Current rating: 1 amp nominal at 10°C above ambient  
 Temperature rating: 80°C standard  
 105°C consult factory  
 Impedance: 105 ohms nominal  
 Capacitance: 13.0 pf/ft. (42,7 pf/m) nominal @ 1MHz  
 Crosstalk: 10' sample, 5 ns rise time with 2 lines driven. NE = 4.7%  
 FE = 4.3% nominal  
 Propagation delay: 1.5 ns/ft. (4.9 ns/m) nominal.  
 Insulation resistance: 10<sup>10</sup> ohms — 10 ft. (3 m) min.  
 UL style number: Component wire style 1061. Cable style 2697 (80°C) standard. For Cable style 20130 (105°C) consult factory.  
 CSA: Cable may be certified under Canadian Standards Association (CSA) Appliance Wiring Material Program (Specify at time of order). CSA AWM I A80°C, 300 V, FT-1.

## other cables in series

Conductors: 12 through 30 AWG solid, stranded, tinned overcoat, top coated, tinned, bare  
 Conductor spacing: .050", .085", .100", .125", .156"

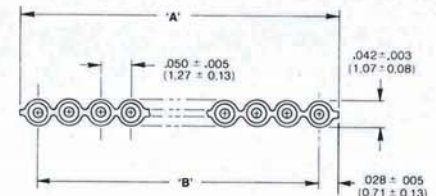

28 AWG SHOWN

## Other Capabilities

Part Number	AWG-Strand	Center line
843-135-2610-XXX	26-7/34	.050"
843-135-2601-XXX	26-7/34	.085"
843-135-2401-XXX	24-7/32	.085"
843-135-2602-XXX	26-7/34	.100"
843-135-2402-XXX	24-7/32	.100"
843-135-2603-XXX	26-7/34	.125"
843-135-2604-XXX	26-7/34	.156"
843-135-2403-XXX	24-7/32	.156"
843-136-2201-XXX	22-7/30	.156"

\*843-136-XXXX-XXX use a 10 mil film.

# Spectra-Strip® high temperature PTFE Teflon® flat cable 141 series

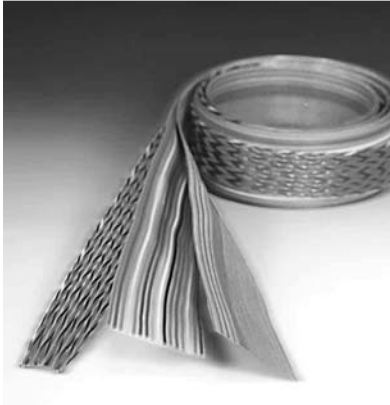

For flat cable applications requiring very high temperature resistance (up to 260° C), low outgassing, high flex life, and resistance to chemical attack, Spectra Strip has developed a rugged line of solid dielectric PTFE Teflon cables.

## Applications

- Robotic Pick and Place X - Y tables requiring high flex life
- Avionics equipment requiring low outgassing
- Missiles / Torpedoes / Smart Bombs requiring high temperature resistance and dense packaging
- Copy machines requiring toner resistance

## Features/Benefits

- Very high temperature resistance -- up to 260° C (Nickel Plate Conductor)
- Voltage rating up to 1000V
- Chemically inert
- Excellent electrical qualities
- Very low coefficient of friction for high flex life applications
- No outgassing as seen in PVC cables
- Excellent solder iron resistance
- Any color code available

## Construction Overview

- Max width 5.00 inches
- Awg range: 30 - 18 awg solid, stranded
- Construction formats:

### Bare Conductor Between Films



### Shielded Pairs



### Triads



### Color Coded Singles



### Twisted Pairs

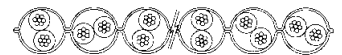

### Shielded Parallel Pairs



- Singles, twisted pairs, triples, quads (components made with MIL-W-16878 type ET, E, or EE primaries of PTFE Teflon) sandwiched between laminate
- Uninsulated conductor sandwiched between laminate
- *Plating:* Silver, Nickel
- *Laminate:* Full density PTFE
- *Conductor centerlines:* as specified by customer

*Teflon is a trademark of Dupont*



## Technical Notes

Source: ICI Technical Service Note F12/13

### Thermal Stability

Within its normal range of working temperatures, the upper limit of which is generally quoted as 260°C (500°F), PTFE suffers no degradation. Indeed weight losses observed between 260° C and 360° C (500 and 680° F) will be exceedingly small and due to the loss of minute amounts of moisture or gas absorbed in the polymer.

At processing temperatures of about 380° C (716° F), the rate of decomposition of PTFE is still very low and it is only at temperatures in excess of 400° C (752° F) that thermal decomposition of pure PTFE becomes significant.

### Melting Point

The melting point of “as polymerized” PTFE increases with increasing molecular weight, and also increases with increasing heating rate.

Melting points determined by Differential Scanning Calorimetry on “as polymerized” powders at a heating rate of 16° C / minute (28.8° F/ minute) vary from about 332° C (630° F) for low molecular weight coagulated dispersion polymer to about 346° C (665° F) for high molecular weight granular material. Measurements made at different heating rates indicate that, owing to the superheating effect, these values may be up to 10° C (18° F) higher than would be obtained at indefinitely slow heating rates.

The influence of molecular weight on melting point is much reduced after the polymer has been sintered (once melted). Most sintered polymers melt in the range of 325-330° C (617-626° F) when reheated at 16° C /minute (28.8° F / minute).

### Chemical Resistance

As might be expected of a saturated aliphatic fluorocarbon, PTFE is almost completely inert chemically. Molten or dissolved alkali metals degrade PTFE by abstracting fluorine from the molecule, while at elevated temperatures fluorine and compounds capable of releasing fluorine can break the carbon skeleton and form low molecular weight fluorocarbons. Apart from these not very important exceptions, PTFE resists attack by all the acids, bases and solvents that might be encountered in industrial practice.

In addition to its remarkable chemical inertness, PTFE is not dissolved or even swollen by any solvent within its normal range of working temperatures. Small quantities of solvents may be absorbed by PTFE on prolonged exposure especially at elevated temperatures, but this in no way impairs the usefulness of the polymer.

## Typical Properties of Unfilled Sintered PTFE

Physical Property	Units	Value
Relative Density	grams/cc	2.1 -2.2
Maximum tensile strength	psi	3000-5000
Elongation at break	%	250-400
Hardness	Shore D	60-65
Coefficient of friction	---	.06
Resistance to weathering	---	excellent
<b>Electrical Property</b>		
Volume Resistivity	ohm / cm	>10 <sup>18</sup>
Dielectric Constant	---	2.1
Loss Factor	---	.0001
<b>Continuous Service Temp.</b>		
	°C	-73 to +260
	°F	-100 to +500

# Jacketed Zip planar cable — 151 series

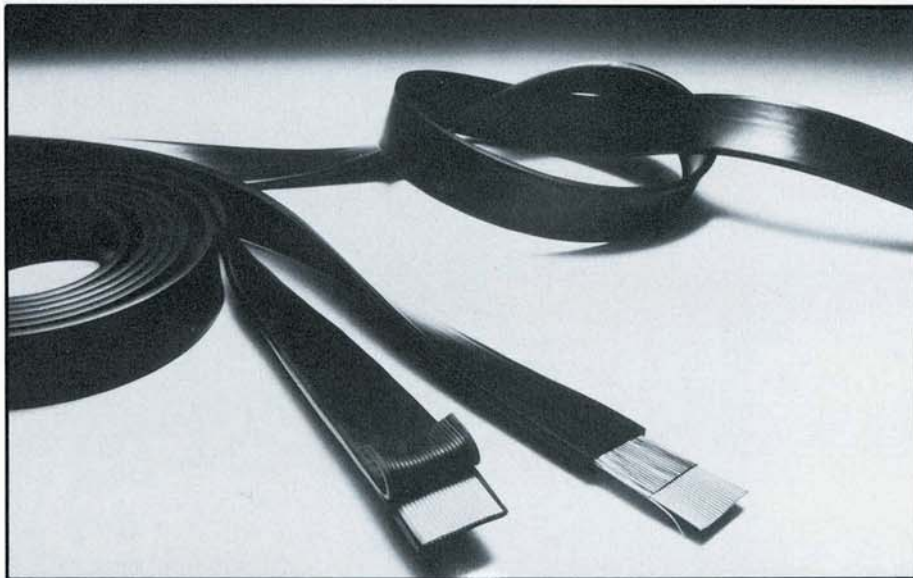

## description

Spectra-Strip Zip extruded jacketed cables combine the ease of termination, consistent electrical characteristics and reduced space requirements of flat cable with the ruggedness of an extruded protective outer jacket — Spectra-Guard®.

It is available with or without integral EMI/RFI shielding. Spectra-Guard provides excellent abrasion resistance, extremely low crosstalk (see test data), consistent electrical characteristics, and high flexibility, making it ideal for high-speed data processing equipment and high frequency communications systems.

Basic component cable consists of 28 (7X36) uninsulated conductors on .050" centers with an extruded PVC insulation. Both the jacket and cable are made of flame-retardant PVC and are UL listed to 105°C (221°F) and 150 volts. Terminates to standard connectors.

We can also provide fully-tested terminated assemblies. For more information, please consult the factory.

## benefits

- Rugged, flexible protection
- Excellent crosstalk and electrical performance
- Available with or without EMI/RFI shielding
- Terminates to standard IDC connectors
- UL CL2 and CSA

## characteristics

### Physical

Conductors: 28 AWG, 7/36 strands, tinned copper  
 Conductors insulation: Gray PVC, flame retardant  
 Conductor spacing: .050" (1,27) typical  
 Shielding (if applicable): Aluminum/poly or expanded copper mesh  
 Drain wires (if applicable): 28 AWG, 7/36 strand, tinned copper  
 Jacket: Black PVC, 30 mil avg.  
 Consult factory for other available thicknesses

### Electrical

Voltage rating: 150 V  
 Temperature rating: 105°C, (221°F),  
 UL Listed Power Limited  
 Circuit Cable CL2  
 CSA: CSA AWM I/II A105°C (221°F),  
 300 V, FT-1

## 151 series capabilities

- 843-151-2811-XXX Zip cable, jacketed with no shield, no drain wires  
 843-151-2831-XXX Zip cable, jacketed, shielded with aluminum poly, two drain wires  
 843-151-2821-XXX Zip cable, jacketed, shielded with expanded copper mesh

Part Number	Wire Gauge Strand	Description	Temp. Rating	Voltage Rating	Impedance Ohms*	1MHz Capacitance pf/ft (pf/m)*	Propagation Delay ns/ft (ns/m)	Insulation Resistance ohms	UL Style
843-151-2811-XXX	28(7/36)	Extruded PVC jacket	105°C 105°C	150V 300V	90	30 (89)	1.6 (5,6)	10 <sup>10</sup> - 10 ft.	2912 20081
843-151-2831-XXX	28(7/36)	Aluminum/poly shield 2 drain wires with extruded PVC jacket	105°C 105°C	150V 300V	50	40 (131)	1.6 (5,2)	10 <sup>10</sup> - 10 ft.	2912 20081

\*Shield floating (GSG)

\*G-S-G/Shield Grounded



# Jacketed Zip planar cable — 151 series

## order information

Part No. & Description	Part No. & Description	No. of Conductors	Dimension "A"	Dimension "B"	Dimension "C"
Extruded PVC Jacket	Aluminum/Poly Shield with Extruded PVC Jacket (2 drain wires)				
843-151-2811-009	843-151-2831-009	9	.450(11,43)	.400±.007(10,16±0,18)	.510
843-151-2811-010	843-151-2831-010	10	.500(12,70)	.450±.007(11,43±0,18)	.560
843-151-2811-014	843-151-2831-014	14	.700(17,78)	.650±.007(16,51±0,18)	.760
843-151-2811-015	843-151-2831-015	15	.750(19,09)	.700±.011(17,78±0,28)	.810
843-151-2811-016	843-151-2831-016	16	.800(20,32)	.750±.011(20,32±0,28)	.860
843-151-2811-020	843-151-2831-020	20	1.000(25,40)	.950 ± .011(24,13 ±0,28)	1.060
843-151-2811-024	843-151-2831-024	24	1.200(30,48)	1.150±.011(29,21±0,28)	1.260
843-151-2811-025	843-151-2831-025	25	1.250(31,79)	1.200±.011(30,48±0,28)	1.310
843-151-2811-026	843-151-2831-026	26	1.300(33,02)	1.250±.011(31,75±0,28)	1.360
843-151-2811-034	843-151-2831-034	34	1.700(43,18)	1.650±.011(41,90±0,28)	1.760
843-151-2811-036	843-151-2831-036	36	1.800(45,72)	1.750±.015(44,45±0,38)	1.860
843-151-2811-037	843-151-2831-037	37	1.850(46,99)	1.800±.015(45,72±0,38)	1.910
843-151-2811-040	843-151-2831-040	40	2.000(50,80)	1.950±.015(49,53±0,38)	2.060
843-151-2811-050	843-151-2831-050	50	2.500(63,50)	2.450±.015(62,23±0,38)	2.560
843-151-2811-060	843-151-2831-060	60	2.000(76,20)	2.950±.015(74,93±0,38)	3.060
843-151-2811-064	843-151-2831-064	64	3.200(81,28)	3.150±.015(80,01±0,38)	3.260

## typical crosstalk characteristics

(10-foot sample, 2-lines driven)

Part Number	Rise Time (ns)	NE %	FE %
843-151-2811 Series	3.0	4.4	1.2
	5.0	4.3	.8
	7.0	4.3	.6
843-151-2831 Series	3.0	.3	.7
	5.0	.2	.5
	7.0	.2	.4

Dimensions and characteristics subject to change without notice.

### 843-151-2811 SERIES UNSHIELDED

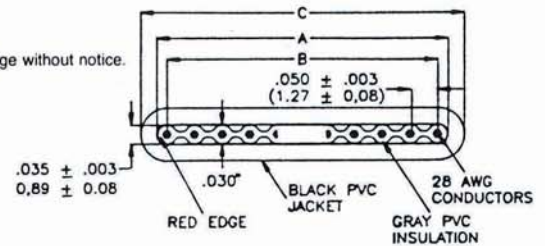

### 843-151-2831 SERIES SHIELDED

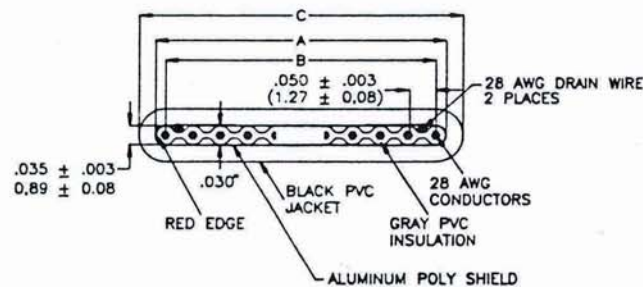



## Twist 'N' Flat<sup>®</sup> jacketed cable with aluminum/poly shield — 152 series

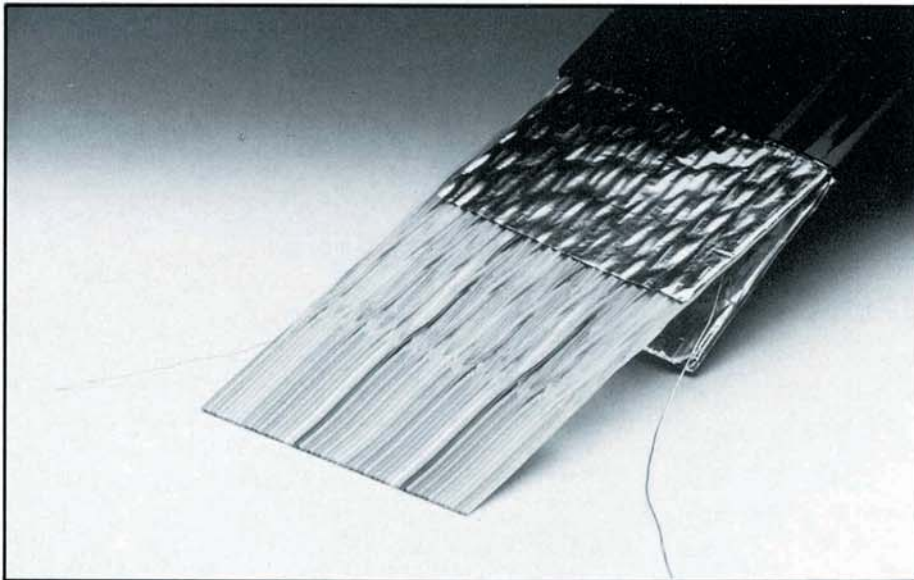

### benefits

- Labor and cost savings
- Twisted-pair electrical characteristics
- Quick and easy mass termination
- EMI/RFI shielding
- Spectra-Guard<sup>®</sup> extruded jacket
- UL CL2 and CSA

### characteristics

#### Inner Cable (Twist 'N' Flat)

Conductor: 28-7/36, tinned copper  
 Insulation: Extruded PVC, .010 nominal wall  
 Laminate: .005 clear PVC (2) layers  
 Temperature: 80°C, (105°C available upon request)  
 Voltage: 300V  
 UL Style: 2697  
 CSA Certified

#### Jacket (Spectra-Guard)

Insulation: Extruded black PVC, .030 min. avg. wall  
 Shield: Aluminum/poly  
 Drains: 28-7/36, tinned copper  
 Temperature: 80°C (105°C available upon request)  
 Voltage: 150V  
 UL Listed Power Limited  
 Circuit Cable CL2  
 CSA AWM I/II A80° 300 V, FT-1.

#### Test Data (10-foot sample)

Capacitance: 22 pf/ft. (S-G/Shield configuration 1 MHz)  
 Impedance: 75 ohm (S-G/Shield configuration)  
 Propagation Delay: 1.6 nsec./ft.

#### 152 series capabilities

843-152-2811-XXX Twist 'N' Flat, jacketed, no shield, no drain wires  
 843-152-2831-XXX Twist 'N' Flat, jacketed, aluminum/poly shielded, two drain wires  
 843-152-2821-XXX Twist 'N' Flat, jacketed, copper mesh shield

### description

With all the labor saving benefits of Twist 'N' Flat, which combines the electrical characteristics of twisted pairs with alternating flat sections for quick and easy mass termination, the addition of shielding and jacketing helps comply with the tough EMI/RFI standards of the FCC.

Jacketed Twist 'N' Flat cable is available in its standard off-the-rack configuration — 2" flat section alternating with an 18" twisted pairs section. It can also be custom-tailored to fit your exact application needs, with flat sections longer than 3" and twisted pairs sections up to 100 feet long.

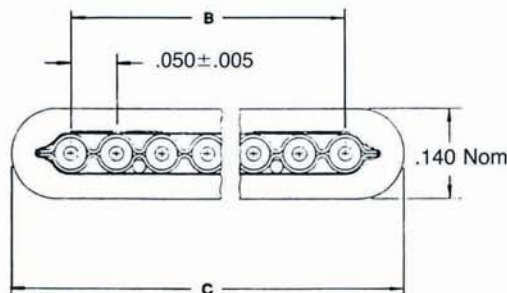

### order information

#### Series 152-2831-0XX

P/N	Cond	C	B	Inner Cable
843-152-2831-010	10	0.590 nom	0.450 ± .015	132-2801-010
843-152-2831-014	14	0.790 nom	0.650 ± .015	132-2801-014
843-152-2831-016	16	0.890 nom	0.750 ± .015	132-2801-016
843-152-2831-020	20	1.090 nom	0.950 ± .015	132-2801-020
843-152-2831-026	26	1.390 nom	1.250 ± .015	132-2801-026
843-152-2831-034	34	1.790 nom	1.650 ± .015	132-2801-034
843-152-2831-040	40	2.090 nom	1.950 ± .020	132-2801-040
843-152-2831-050	50	2.590 nom	2.450 ± .020	132-2801-050
843-152-2831-060	60	3.090 nom	2.950 ± .020	132-2801-060

# Spectra-Strip® round 'n' flat™ 159-2801 series

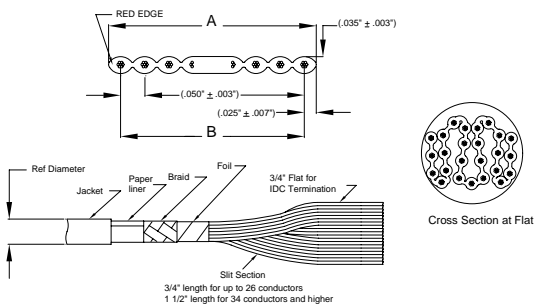

Round 'N' Flat™ cable combines into a single construction, the handling and shielding features of round cable and the mass termination capabilities of flat cable. This product is designed for routing in tight spaces where a round shape is more practical and where a foil braid shield is necessary to help meet FCC requirements for EMI/RFI suppression.

The inner cable is extruded Spectra-Zip® with alternating sections that are flat and slit. Each flat section is 3/4" in length with conductors on controlled spacing of .050" ± .003" making it ideally suited

for IDC mass termination methods. The alternating flat and slit sections also offer an advantage over standard round cable for hand termination. The flat sections keep the conductors aligned for conductor positioning while the slit zip feature provides easy breakout of individual conductors.

One edge of the flat cable is marked for conductor referencing. Two layers of shielding, aluminum- polyester foil and tinned copper braid, are used to protect signals from EMI interference.

## Order Information

Series 159-2801-0XX AWG 28-7/36, .050" centers

Part Number	No. Cond.	Width 'A'		Span 'B'		Ref. Dia. Inches
		Inches	(mm)	Inches	(mm)	
843-159-2801-009	9	.450	(11,43)	.400±.007	(10,16±0,18)	.270
843-159-2801-010	10	.500	(12,70)	.450±.007	(11,43±0,18)	.270
843-159-2801-015	15	.750	(19,05)	.700±.011	(17,78±0,28)	.300
843-159-2801-016	16	.800	(20,32)	.750±.011	(19,05±0,28)	.310
843-159-2801-020	20	1.000	(25,40)	.950±.011	(24,13±0,28)	.330
843-159-2801-024	24	1.200	(30,48)	1.150±.011	(29,21±0,28)	.350
843-159-2801-025	25	1.250	(31,75)	1.200±.011	(30,48±0,28)	.360
843-159-2801-026	26	1.300	(33,02)	1.250±.011	(31,75±0,28)	.360
843-159-2801-034	34	1.700	(43,18)	1.650±.011	(41,91±0,28)	.400
843-159-2801-036	36	1.800	(45,72)	1.750±.015	(44,45±0,38)	.410
843-159-2801-037	37	1.850	(47,00)	1.800 ±.015	(45,72±0,38)	.410
843-159-2801-040	40	2.000	(50,80)	1.950 ±.015	(49,53±0,38)	.430
843-159-2801-050	50	2.500	(63,50)	2.450 ±.015	(62,23±0,38)	.480
843-159-2801-060	60	3.000	(76,20)	2.950 ±.015	(74,93±0,38)	.520
843-159-2801-064	64	3.200	(81,28)	3.150 ±.015	(80,01±0,38)	.530

Shielding Variations: -0XX Foil/Braid, -1XX Foil only, -2XX No Shield, Jacket only

## Benefits

- . Round cable that mass terminates
- . High flexibility
- . Helps meet FCC requirements
- . UL, CL2
- . CSA Certified

## Physical characteristics

Conductors: 28 AWG, 7/36 Tinned Copper  
 Color code: Gray with Red Edge  
 Insulation: PVC, .010" WALL  
 Thickness: .035" ± .003"  
 Pitch: .050" ± .003"  
 Shielding: Aluminum/Polyester Foil, with Minimum 85% Coverage Tinned Copper Braid  
 Jacket: Black PVC, .030" nom Wall  
 Liner: Paper Liner Between Jacket and Braid  
 Temperature Rating: -20°C to +105°C (-4°F to 221°F)  
 UL style: Inner Cable: 2651  
 Composite: UL Listed Power Limited Circuit Cable CL2  
 CSA AWM I/II A 105°C 300V, FT-1

## Electrical

Voltage: 300 volts  
 \*Impedance: 75 ohms  
 \*Capacitance: 24 pf/ft at 1 MHz (78.7 pf/m)  
 \*Inductance: .15 µH/ft at 1 MHz (.49 µH/m)  
 Propagation delay: 1.60 ns/ft (5.25 ns/m)  
 \*Above values measure in the ground-signal-ground mode with the shield also grounded.

Reference diameters for -1XX and -2XX are .030" to .040" smaller than above. Standard put-up is 100 feet on cardboard reels. Consult factory for larger put-ups.



# Spectra-Strip® Round Twist 'N' Flat™ jacketed shielded cable — 159-2832 series



## description

Round Twist 'N' Flat cable combines into a single construction, the handling and shielding features of round cable and the mass termination capabilities of flat cable. This product is designed for routing in tight spaces where a round shape is more practical and where a foil/braid shield is necessary to help meet FCC requirements for EMI/RFI suppression.

The inner cable is composed of twisted pairs with alternating flat sections. Each flat section is 2½" in length with conductors on controlled spacing of .050" ± .005", making it ideally suited for IDC mass termination methods. The twist portion has alternating slit and unslit sections, which also offers an advantage over standard round cable for hand terminations. The unslit sections keep the pairs aligned for conductor positioning, while the slit feature provides easy breakout of individual conductors.

The standard product is color coded with a tan common in each pair. Two layers of shielding—aluminum-polyester foil and tinned copper braid—are used to protect signals from EMI interference. This product can also be designed with shielding reduced or eliminated.

## dimensions

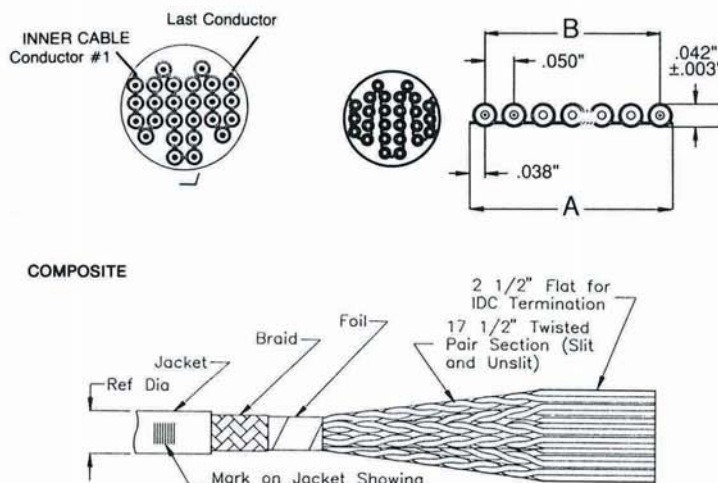

## benefits

- Round cable that mass terminates
- High flexibility
- Twisted pair electrical characteristics
- Helps meet FCC regulations
- UL CL2 and CSA

## characteristics

### Physical

Conductors: 28 AWG-7/36 tinned copper  
 Color code: Brown, red, orange, yellow, green, blue, violet, gray, white, black and repeat with tan common  
 Insulation: PVC, .010" wall laminated between .005" clear PVC film  
 Thickness: .042" ± .003"  
 Pitch: .050" ± .005"  
 Twist length: 17.5 inches (consult factory for other available lengths)  
 Flat length: 2.5 inches  
 Shielding: Aluminum/polyester foil, with minimum 85% coverage tinned copper braid  
 Temperature rating: -20° to +105°C (-4° to +221°F)  
 UL style: Inner cable: 20130;  
 composite: UL Listed Power Limited Circuit Cable CL2  
 CSA AWM I/II A105°C 300 V, FT-1

### Electrical

Voltage: 300 volts  
 \*Impedance: 70 ohms  
 \*Capacitance: 25 pf/ft at 1MHz (82.0 pf/m)  
 \*Inductance: .21 uh/ft at 1 MHz (.69 uh/m)  
 Propagation delay: 1.65 ns/ft (5.58 ns/m)  
 Insulation resistance: 10<sup>10</sup> ohms-10 ft, min.  
 Crosstalk: Unbalanced: NE 2.3% FE 1.3% 10 ft sample, 5ns risetime, 2 lines driven; Balanced: see chart  
 \*Above values measured in the ground-signal mode with the shield also grounded

# Spectra-Strip® Round Twist 'N' Flat™ jacketed shielded cable — 159-2832 series

## balanced crosstalk

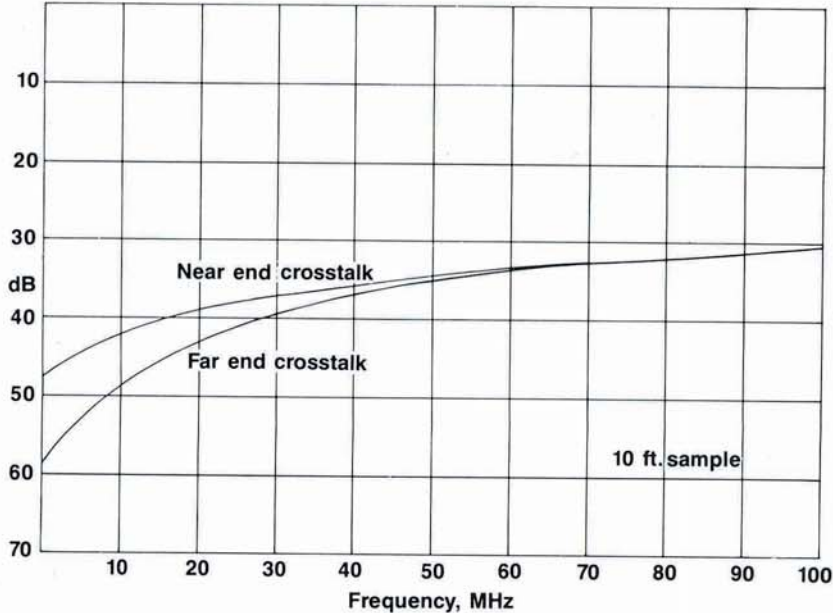

## order information

Series 843-159-2832-0XX 28 AWG—7/36, .050" centers

Part Number	No. Pairs	Width 'A'		Span 'B'		Ref. Dia. Inches
		Inches	(mm)	Inches	(mm)	
843-159-2832-010	5	.526	(13,36)	.450	11,43	.300
843-159-2832-014	7	.726	(18,44)	.650	16,51	.330
843-159-2832-016	8	.826	(20,98)	.750	19,05	.340
843-159-2832-020	10	1.026	(26,06)	.950	24,13	.380
843-159-2832-026	13	1.326	(33,68)	1.250	31,75	.410
843-159-2832-034	17	1.726	(43,84)	1.650	41,91	.450
843-159-2832-040	20	2.026	(51,46)	1.950	49,53	.480
843-159-2832-050	25	2.526	(64,16)	2.450	62,23	.530
843-159-2832-060	30	3.026	(76,86)	2.950	74,93	.570
843-159-2832-064	32	3.226	(81,94)	3.150	80,01	.580

## 159 series capabilities

843-159-2832-0XX Round Twist 'N' Flat, aluminum/poly shield, tinned copper braid

843-159-2832-1XX Round Twist 'N' Flat, aluminum/poly shield only, no braid

843-159-2832-2XX Round Twist 'N' Flat, no shield, clear poly only

Reference diameters for -1XX and -2XX are .030" to .040" smaller than above.

Standard put-up is 100 feet on cardboard reels. Longer lengths are available upon request.



# Spectra-Strip® loose pair round twist'n'flat® 169-2832 series

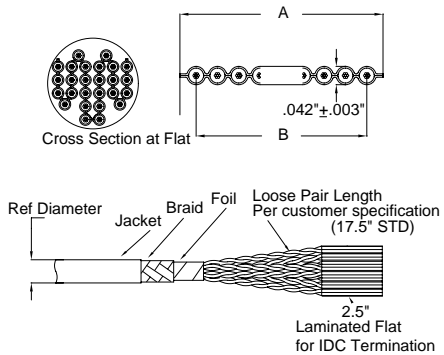

## Order Information

Series 169-2832-0XX AWG 28 7/36, .050" centers

Part Number	No. Pairs	Width 'A'		Span 'B'		Ref. Dia. Inches	
		Inches	(mm)	Inches	(mm)	0XX	1XX 2XX
169-2832-O10	5	.526	(13.36)	.450	(11.43)	.250	.220
169-2832-O14	7	.726	(18.44)	.650	(16.51)	.260	.230
169-2832-O16	8	.826	(20.98)	.750	(19.05)	.280	.250
169-2832-O20	10	1.026	(26.06)	.950	(24.13)	.290	.260
169-2832-O26	13	1.326	(33.68)	1.250	(31.75)	.310	.280
169-2832-O34	17	1.726	(43.84)	1.650	(41.91)	.360	.330
169-2832-O40	20	2.026	(51.46)	1.950	(49.53)	.390	.360
169-2832-O50	25	2.526	(64.16)	2.450	(62.23)	.430	.400
169-2832-O60	30	3.026	(76.86)	2.950	(74.93)	.470	.440
169-2832-O64	32	3.226	(81.94)	3.150	(80.01)	.480	.450

Shielding Variations: -0XX Foil/Braid, -1XX Foil only, -2XX No Shield, Jacket only

## Benefits

Loose Pair Round Twist 'N' Flat® cable is designed to combine the electrical performance and handling features of discrete twisted pair cable with the mass termination capabilities of flat ribbon cable.

The inner cable consists of 28-7 AWG tinned copper conductors insulated with PVC and twisted into loose pairs. Conductors are laminated in parallel on .050" conductor spacing every 20 inches to accept termination to insulation displacement connectors. Laminated .050" areas can be

fabricated at custom intervals. Minimum twist length is 6", maximum twist length is determined by size of put-up.

The loose twisted pairs are wrapped in aluminum polyester foil shield and overall tinned copper braid to help meet FCC requirements for EMI/RFI suppression. A round .030" PVC jacket is extruded over the cable for maximum protection and ease of routing. The center of each laminated .050" area is visible on the outer jacket to locate connector terminating areas quickly and easily.

## Physical characteristics

Conductors: 28-7/36 AWG Tinned Copper  
 Color Code: Brown, Red, Orange, Yellow, Green, Blue, Violet, Gray, White, Black and Repeat with Tan Common.  
 Insulation: Extruded .010" PVC Wall  
 (Laminated Between .005" clear PVC Films at Flat Sections)  
 Flat Pitch: .050"  
 Shielding: Aluminum/Polyester Foil with Minimum 85% Coverage Tinned Copper Braid  
 Jacket: Black PVC, .030" Wall  
 Temperature Rating: -20° C to +105° C (-4° F to 221° F)  
 Approvals: 169-2832-0XX  
 Inner cable: UL Recognized AWM 20130  
 Composite: UL CL2 CSA AWM I/II A105°C 300V, FT-1  
 UL Listed Type: CL2 CSA Certified

## Electrical

Voltage: 300 Volts  
 \*Impedance: 70 ohms  
 \*Capacitance: 25 pf/ft at 1 MHz (82.0 pf/m)  
 \*Inductance: .13 uH/ft at 1 MHz (.43 uH/m)  
 Propagation Delay: 1.70 ns/ft (5.58 ns/m)  
 Insulation Resistance: 10<sup>10</sup> ohms - 10 ft. min.  
 \*Above values measured in the ground-signal mode with the shield also grounded.

Cross Talk:

Balanced - See chart  
 Unbalanced - 10 ft. sample, 5 ns Risetime  
 2 Lines Driven  
 Near End - 2.3%  
 Far End - 1.3%

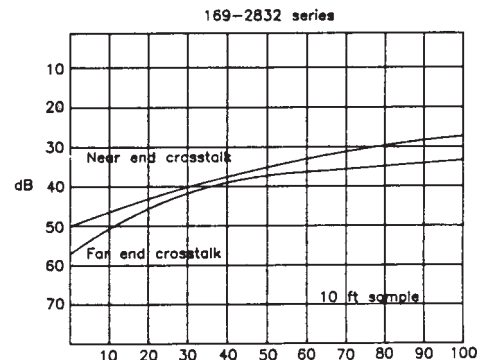



# Spectra-Strip® Round 'N' Flat™ termination press — 324-0420 series

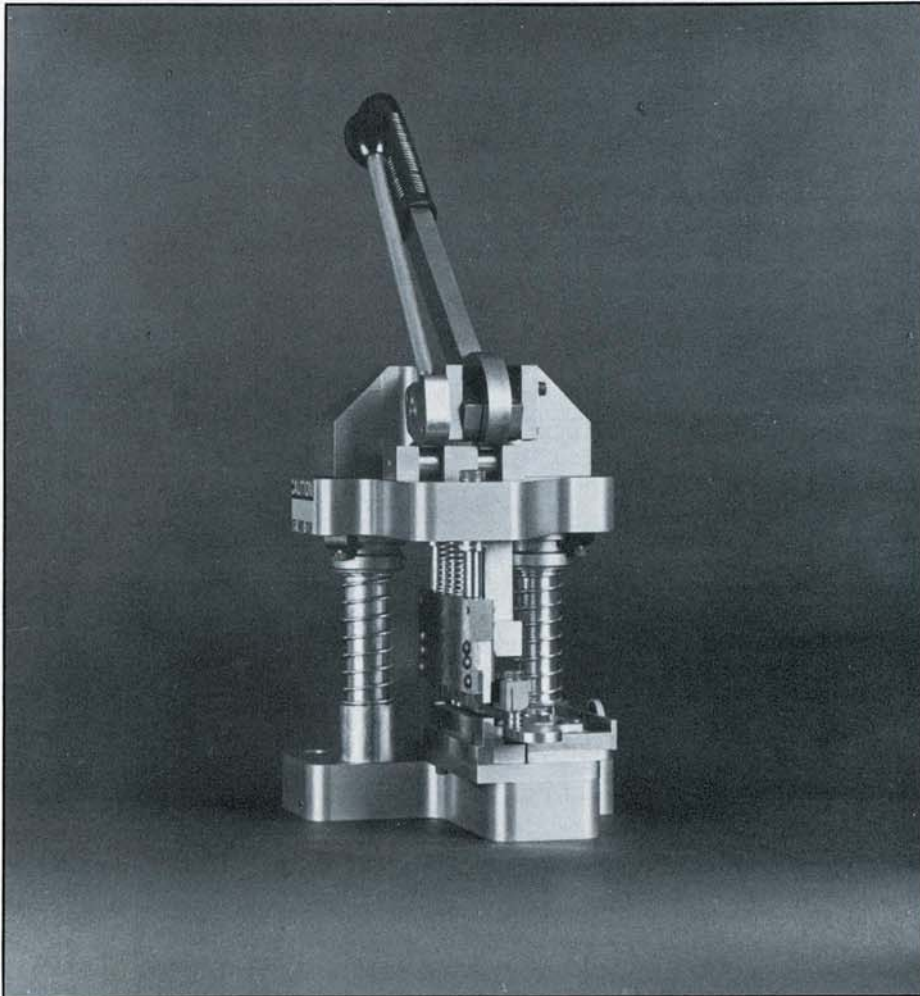

## benefits

- Holds 159/169 series Round'N'Flat and Round Twist'N'Flat cable securely in position for ease of termination
- Cuts cable end square for proper connector alignment
- Quickly terminates up to 64 conductors without prestripping
- Makes daisy-chain interconnections
- Allows visual inspection of termination
- Rugged, lightweight and portable

## description

Specifically designed for **159 series Round 'N' Flat and Round Twist 'N' Flat cable**, this termination press is available as a complete system. All tools necessary for adjustment or change of connector series base plates are included. Base plates for each connector series will accommodate all available sizes of that series connector housings.

## order information

Termination press with 812 series socket connector base plate, 1/8" and 5/32" allen wrenches — P/N 324-0420-001

### other available connector base plates:

812 series socket connector — P/N 324-0021-003

817 series D-sub connector — P/N 324-0021-008

841 series D-sub connector — P/N 324-0021-009

850 series Micro-ribbon 57F — P/N 324-0021-010

Note: D-sub series connectors require a special anvil (P/N 324-0021-902) for some termination procedures. Consult Spectra-Strip® Cable Operations at 1-800-846-6400 for additional information.

# Spectra-Strip® Round 'N' Flat™ termination press — 324-0420 series

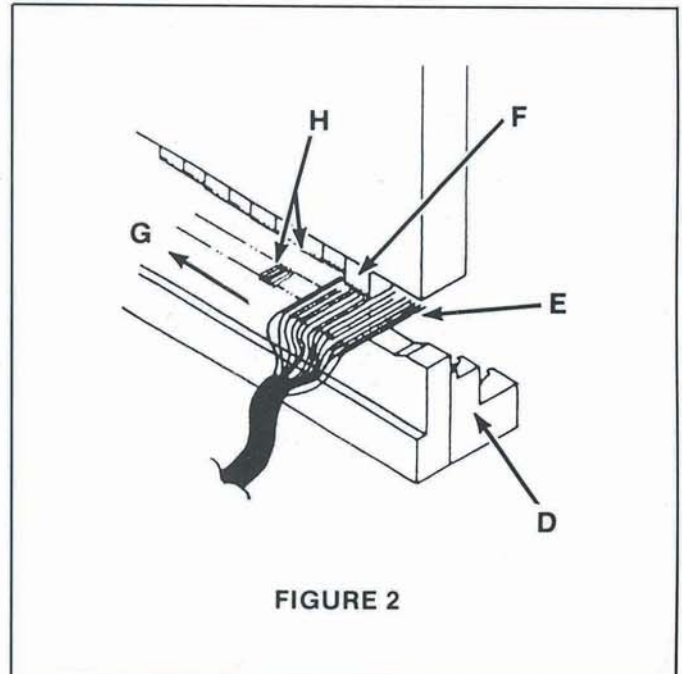
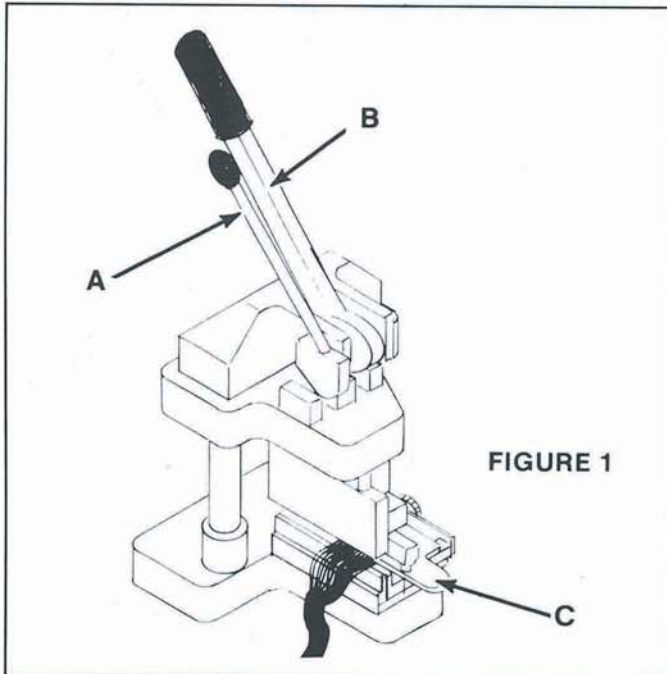

## preliminary set-up

- Install required connector base (D) with two screws.
- Adjust cutter assembly (C) to base.
- Prepare cable.

## termination procedure

- Place flattened cable through cable hold area (E).
- Pull handle (A) forward to engage first five conductors (F).
- Pull remaining conductors toward back of press (G).
- Pull handle (A) remaining distance forward to lock cable in place, one conductor per groove (H).
- Cable is locked in position.
- Pull handle (B) forward to trim end of cable.
- Move cutter assembly (C) away from connector base.
- Place connector on connector base and between cable end.
- Pull handle (B) forward to close connector.
- Termination is complete, release both handles.

## daisy chain termination

- Daisy chains can be terminated using the same procedure described above.
- The only change required is to swing the cutting assembly (C) out of the termination area.



# Spectra-Zip<sup>®</sup> planar cable 191-2601 series



## description

Spectra-Zip cable consists of 26 AWG stranded round conductors insulated with gray PVC on .050" centers to form a planar cable. This cable is designed for mass termination IDC type connectors. A tear feature built into the cable allows easy, uniform breakouts without rupturing the insulation.

Spectra-Zip planar cable offers a balanced combination of economy, reliable performance, weight and space savings, controlled electrical characteristics, and low-cost termination for general-purpose interconnection in electronic products from calculators and automobiles to computers and switching networks.

## benefits

- Economical with reliable performance.
- Cost-effective IDC termination.
- Tear feature allows easy, uniform breakouts without rupturing the insulation.

## characteristics

### Physical

*Conductors:* 26 AWG 7/34 strand, tinned copper  
*Insulation:* Extruded PVC, .010" wall  
*Color:* Gray, one edge red  
*Conductor Spacing:* .050 ±.002"  
*Cable Thickness:* .039 ±.003"  
*Temperature Rating:* -20° to 105° C (-4° to 22°F)

### Electrical

*Voltage Rating:* 300 volts per UL style  
*Current Rating:* 1.5 amps nominal at 10° rise above ambient.  
*Impedance:* 92 ohms  
*Capacitance:* 16.5 pF/ft @ 1.0 MHz  
*Inductance:* .15 µH/ft @ 1.0 MHz  
*Propagation Delay:* 1.5 ns/ft  
*Insulation Resistance:* 10<sup>10</sup> ohms - 10 ft., min  
*Cross Talk:* 10 ft sample, 5 ns rise time, 2 lines driven, near end- 3.5% max; far-end 5.0% max

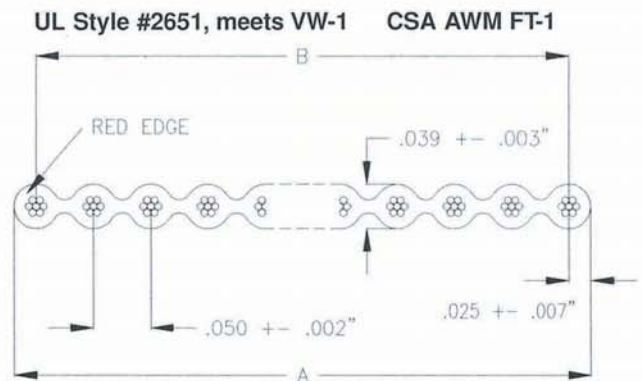

PART #	# COND	WIDTH A (nominal)		SPAN B	
		INCHES	(mm)	INCHES	(mm)
191-2601-110	10	0.500	(12,70)	0.450 ±.007	(11,43 ±0,18)
191-2601-114	14	0.700	(17,78)	0.650 ±.007	(16,51 ±0,18)
191-2601-116	16	0.800	(20,32)	0.750 ±.011	(19,05 ±0,28)
191-2601-120	20	1.000	(25,40)	0.950 ±.011	(24,13 ±0,28)
191-2601-125	25	1.250	(31,75)	1.200 ±.011	(30,48 ±0,28)
191-2601-126	26	1.300	(33,02)	1.250 ±.011	(31,75 ±0,28)
191-2601-134	34	1.700	(43,18)	1.650 ±.011	(41,91 ±0,28)
191-2601-137	37	1.850	(46,99)	1.800 ±.015	(45,72 ±0,38)
191-2601-140	40	2.000	(50,80)	1.950 ±.015	(49,53 ±0,38)
<b>*191-2601-150</b>	<b>50</b>	<b>2.500</b>	<b>(63,50)</b>	<b>2.450 ±.015</b>	<b>(62,23 ±0,38)</b>
191-2601-160	60	3.000	(76,20)	2.950±.015	(74,93 ±0,38)
191-2601-164	64	3.200	(81,28)	3.150 ±.015	(80,01 ±0,38)

\* Used for Fast 20 SCSI, 8 bit narrow applications



# Spectra-Zip<sup>®</sup> planar cable

## — 191-2801 series

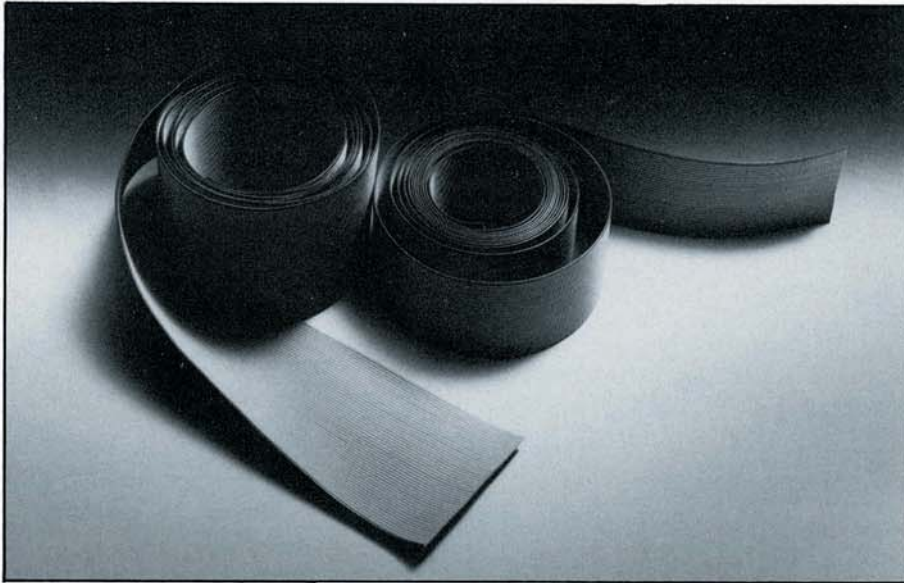

### description

Spectra-Zip planar cable offers a balanced combination of economy, reliable performance, weight and space savings, controlled electrical characteristics, and low-cost termination for general-purpose interconnection in electronic products from calculators and automobiles to computers and switching networks.

Spectra-Zip cable consists of stranded round conductors insulated with gray PVC to form a planar cable. The insulation is extruded around the conductors so that the cable has a "double contour" to allow for mounting IDC connectors on either surface of the cable. A tear feature built into the cable allows easy, uniform breakouts without rupturing the insulation. Spectra-Zip cable is packaged in 100-foot putups in dispenser boxes.

For other wire gauges, spacing materials and lengths, please consult the Spectra-Strip sales office nearest you.

### order information

Series 843-191-2801-XXX

Part Number	No. Cond.	Width 'A'		Span "B"	
		Inch	(mm)	Inch	(mm)
843-191-2801-109	9	.450	(11,43)	.400 ± .007	(11,43 ± 0,18)
843-191-2801-110	10	.500	(12,70)	.450 ± .007	(11,43 ± 0,18)
843-191-2801-114	14	.700	(17,78)	.650 ± .007	(16,51 ± 0,18)
843-191-2801-115	15	.750	(19,05)	.700 ± .007	(17,78 ± 0,18)
843-191-2801-116	16	.800	(20,32)	.750 ± .011	(19,05 ± 0,28)
843-191-2801-120	20	1.000	(25,40)	.950 ± .011	(24,13 ± 0,28)
843-191-2801-124	24	1.200	(30,48)	1.150 ± .011	(29,21 ± 0,28)
843-191-2801-125	25	1.250	(31,75)	1.200 ± .011	(30,48 ± 0,28)
843-191-2801-126	26	1.300	(33,02)	1.250 ± .011	(31,75 ± 0,28)
843-191-2801-134	34	1.700	(43,18)	1.650 ± .011	(41,91 ± 0,28)
843-191-2801-136	36	1.800	(45,72)	1.750 ± .015	(44,45 ± 0,38)
843-191-2801-137	37	1.850	(47,00)	1.800 ± .015	(45,72 ± 0,38)
843-191-2801-140	40	2.000	(50,80)	1.950 ± .015	(49,53 ± 0,38)
843-191-2801-150	50	2.500	(63,50)	2.450 ± .015	(62,23 ± 0,38)
843-191-2801-160	60	3.000	(76,20)	2.950 ± .015	(74,93 ± 0,38)
843-191-2801-164	64	3.200	(81,28)	3.150 ± .015	(80,01 ± 0,38)

843-191-2801-0XX UL Now Supplied As 1XX UL/CSA 3XX = 300' Rolls

24 720 Sherman Avenue Hamden CT, 06514 in CT, call 1.203.281.3200 Fax 1.203.281.5872  
1.800.846.6400 sales@spectra-strip.com http://www.spectra-strip.com

### benefits

- Fast, low-cost mass termination.
- Precise spacing for controlled electrical characteristics.
- Flexible gray PVC insulation.
- Double contour allows termination from either side of cable.
- Easy conductor separation for circuit routing.
- UL recognized  and CSA certified.

### Physical

Conductors: 28 AWG, 7/36 strand tinned copper  
Number of conductors: 10, 14, 16, 20, 24, 25, 26, 34, 36, 37, 40, 50, 60 and 64  
Color: Gray (one edge red)  
Conductor spacing: .050" ± .002"  
Cable thickness: .035" ± .003"  
Insulation: Gray PVC, flame retardant VW-1

### Electrical

Voltage rating: 300 V  
Current rating: 1 amp nominal at 10°C above ambient  
Temperature rating: 105°C, (221°F)  
Impedance: 105 ohms nominal  
Capacitance: 14 pf/ft. (45,9) pf/m nominal @ 1 MHz  
Crosstalk: 10' sample 5 ns rise time with 2 lines driven  
NE = 3.0%, FE = 4.0% nominal  
Propagation delay: 1.5 ns/ft. (4,9 ns/m) nominal  
Insulation resistance: 10<sup>10</sup> ohms — 10 ft. min.  
UL style number: Cable style 2651  
CSA: CSA AWM I A105° (221°F), 300 V, FT-1.

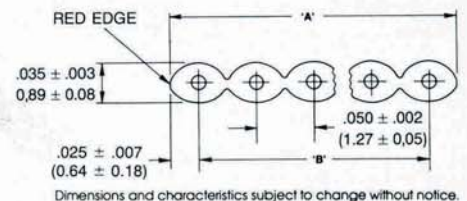

### other cable capabilities

Part Number	AWG-Strand	Center-line)
843-191-3001-XXX	30 AWG (1 × 30)	.050"
843-191-2802-XXX	28 AWG (1 × 28)	.050"
843-191-2601-XXX	26 AWG (7 × 34)	.050"
843-191-2602-XXX	26 AWG (1 × 26)	.050"
843-191-2401-XXX	24 AWG (7 × 32)	.075"



# Spectra-Strip® Spectra-Flex™ high flex life flat cable — 191-2811 series

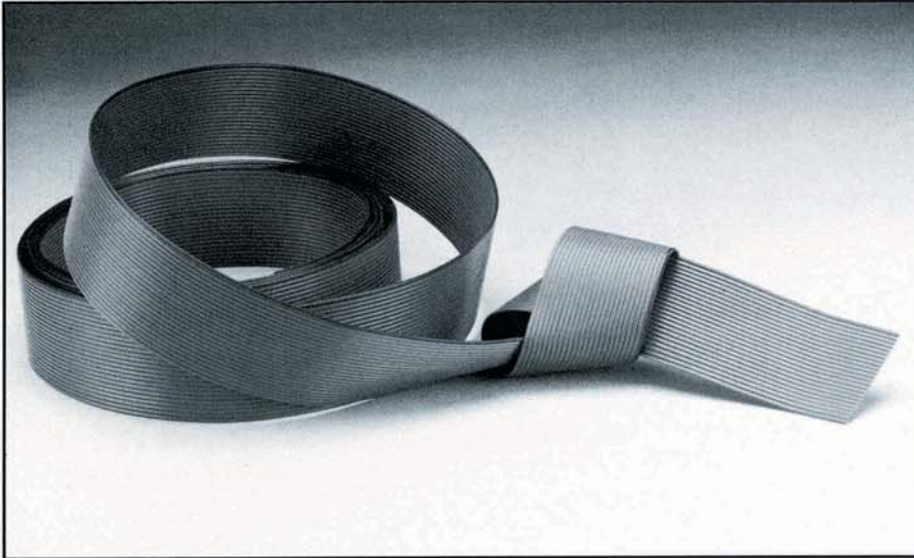

## description

The new Spectra-Flex high flex life flat cable is designed for applications that require repeated flexing without circuit interruption. A typical use would be for printers that need a flexible cable to cyclically travel back and forth, or any other application where constant flexing is required.

## order information

### Series 843-191-2811-XXX

Part Number	No. Conds.	Width "A"		Span "B"	
		Inch	(mm)	Inch	(mm)
843-191-2811-010	10	.500	(12,70)	.450 ± .007	(11,43 ± 0,18)
843-191-2811-014	14	.700	(17,78)	.650 ± .007	(16,51 ± 0,18)
843-191-2811-016	16	.800	(20,32)	.750 ± .011	(19,05 ± 0,28)
843-191-2811-020	20	1.000	(25,40)	.950 ± .011	(24,13 ± 0,28)
843-191-2811-026	26	1.300	(33,02)	1.250 ± .011	(31,75 ± 0,28)
843-191-2811-034	34	1.700	(43,18)	1.650 ± .011	(41,91 ± 0,28)
843-191-2811-040	40	2.000	(50,80)	1.950 ± .015	(49,53 ± 0,38)
843-191-2811-050	50	2.500	(63,50)	2.450 ± .015	(62,23 ± 0,38)
843-191-2811-060	60	3.000	(76,20)	2.950 ± .015	(74,93 ± 0,38)
843-191-2811-064	64	3.200	(81,28)	3.150 ± .015	(80,01 ± 0,38)

All of the above constructions are available with nickel coated copper alloy conductors. Simply use part number series 843-191-2812-XXX when ordering.

## packaging

Standard put-ups are 100-ft. (30,48 meter) rolls. Consult factory for special put-up requirements.

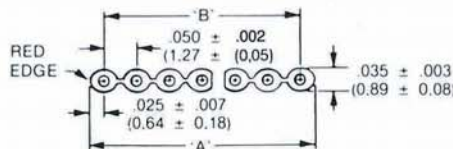

## benefits

- Made with special alloy conductors which can withstand continuous flexing
- Conductor spacing on 0.050" (1.27mm) centers with one edge conveniently marked for conductor reference, allows IDC mass termination, reduces labor
- UL recognized 
- CSA certification available

## characteristics

### Physical

Conductor: 28AWG, 19/40 silver plated copper alloy  
 Insulation: PVC  
 Thickness: .035" ± .003"  
 Pitch: .050" ± .002"  
 Color: Blue with red edge  
 Flex life: >100 million cycles ("rolling" flex test, 5½" stroke with 1" bend radius)

### Electrical

Voltage: 300 volts  
 Impedance: 100 ohms, nom. (ground-signal-ground)  
 Capacitance: 14 pf/ft. (45,9 pf/m) nom. (1MHz)  
 Crosstalk: 10' sample, 5 ns rise time with 2 lines driven; NE = 3.0%, FE = 4.0% nom.  
 Propagation delay: 1.4 ns/ft. (4,6 ns/m) nom.  
 Insulation resistance: 10<sup>10</sup> ohms—10 ft min.  
 Temperature rating: 105°C  
 UL style: Cable style 2651



# Spectra-Zip® 1,00 mm planar cable

## 191-2815 series

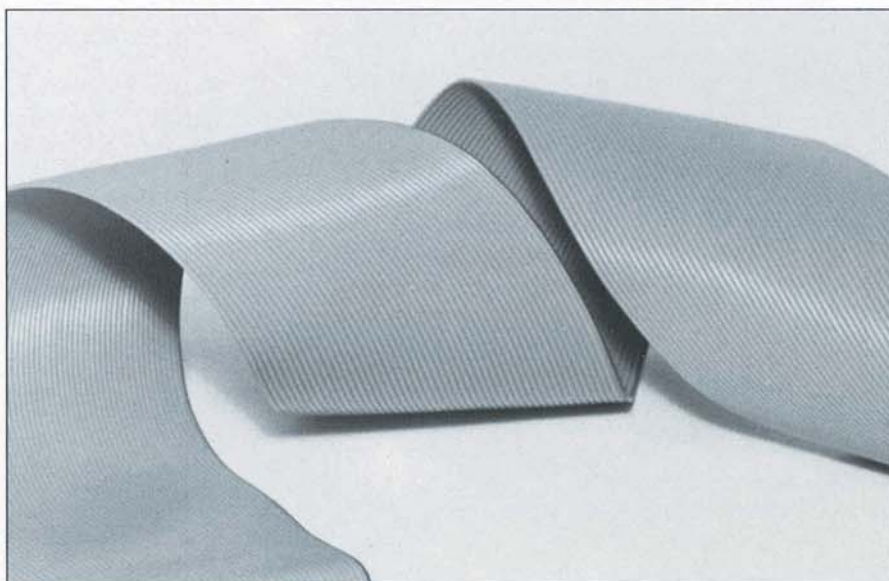

### description

Spectra-Zip 1,00 mm cable is designed for use with 2,00 mm hard metric mass terminable IDC connectors...a standardized utility connector widely used by disk drive and other manufacturers concerned with effective utilization of available board real estate. This cable is reliable and economical, with controlled electrical characteristics. Spectra-Zip 1,00 mm cable consists of stranded round conductors insulated with extruded PVC. Packaged in 100-foot put-ups.

### benefits

- High density center-to-center spacing
- Easy, fast termination to 2,00 mm hard metric IDC connectors
- Easy identification of # 1 conductor with blue edge mark
- Double contour allows termination from either side of cable
- Tear feature allows easy conductor separation for circuit routing without rupturing insulation
- UL and CSA

### order information

PART #	# COND	WIDTH A		SPAN B	
		mm	inches	mm	inches
191-2815-010	10	9,89	.3897	8,99±0,20	.3543±.0079
191-2815-014	14	13,89	.5472	12,99±0,20	.5118±.0079
191-2815-016	16	15,90	.6260	15,00±0,20	.5906±.0079
191-2815-020	20	19,89	.7834	18,99±0,20	.7480±.0079
191-2815-024	24	23,89	.9409	22,99±0,20	.9055±.0079
191-2815-026	26	25,90	1.0197	25,00±0,20	.9843±.0079
191-2815-034	34	33,89	1.3346	32,99±0,30	1.2992±.0118
191-2815-040	40	39,89	1.5708	38,99±0,30	1.5354±.0118
191-2815-044	44	43,89	1.7283	42,99±0,30	1.6929±.0118
191-2815-050	50	49,89	1.9645	48,99±0,30	1.9291±.0118
191-2815-060	60	59,89	2.3582	58,99±0,30	2.3228±.0118
191-2815-064	64	63,89	2.5157	62,99±0,35	2.4803±.0138
191-2815-068	68	67,89	2.6724	66,99±0,35	2.6378±.0138
191-2815-075	75	74,89	2.9475	73,99±0,35	2.9134±.0138

Dimensions and characteristics subject to change without notice.

### characteristics

#### physical

*Conductors:* 28 AWG, 7/36 strand, tinned copper  
*Insulation:* .010" wall extruded, PVC, flame retardant VW-1  
*Thickness:* 0,9 ±0,08 mm (.0354" ±.0031")  
*Pitch:* 1,0 ±0,08 mm (.0394" ±.0031") centers  
*Color:* gray (one blue edge)  
*Temperature rating:* -20°C to +105°C

#### electrical

*Voltage:* 300 V  
*Current rating:* 1 amp nominal @ 10°C above ambient  
*Impedance:* 83 ohms nominal  
*Capacitance:* 60,0 pf/m (18.3 pf/ft) nominal @ 1.0 MHz  
*Inductance:* 0,50 µh/m (.15 µh/ft) nominal @ 1.0 MHz  
*Propagation delay:* 5.2 ns/m (1.58 ns/ft) nominal  
*Insulation resistance:* 10<sup>10</sup> ohms - 3 m (10') min.  
*Unbalanced crosstalk:* 3 m (10') sample, 5 ns rise time with 2 lines driven, near end = 3.1% nominal, far end = 4.0% nominal  
*Mode:* ground-signal-ground

*UL:* recognized, AWM 2651, meets VW-1  
*CSA:* certified, class I group A, FT-1

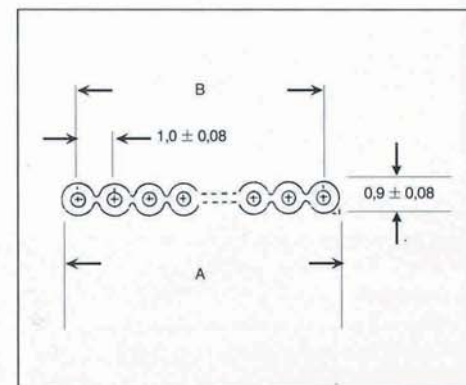



# TPE Insulated Zip Cable

## 193-2801 Series

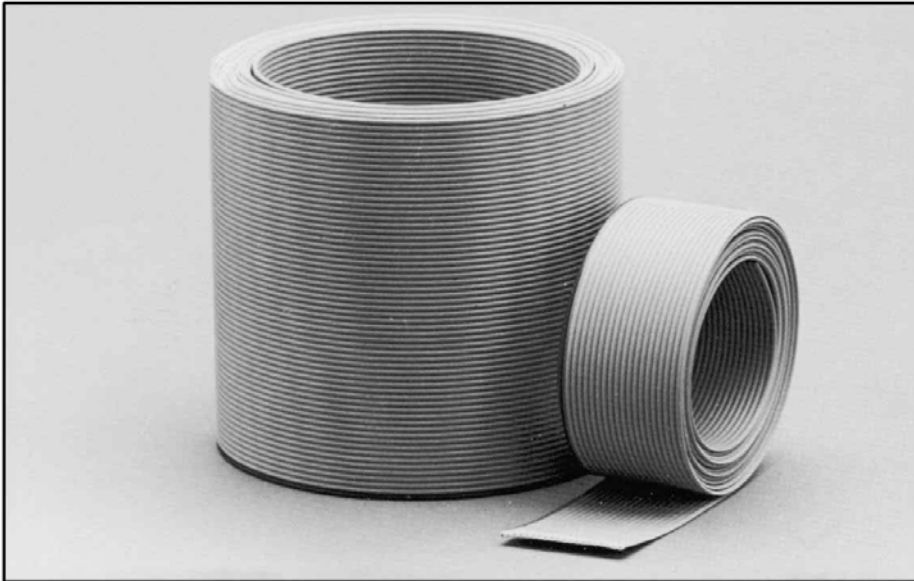

### description

TPE Zip Cable is designed to provide faster signal transmission speed and lower capacitance characteristics than equivalent standard flat ribbon cable constructions. The Thermoplastic Elastomer (TPE) insulation allows this cable to be used in more severe operating environments with wider temperature ranges (-65°C to +125°C)

This cable consists of 28 AWG stranded round conductors on .050" centers with an extruded TPE insulation. It is UL recognized at a rating of 125°C, 300 volts (Ref UL Style #20559).

### cable selection chart

PART NUMBER	NO. COND.	WIDTH 'A'		SPAN 'B'	
		INCHES	(MM)	INCHES	(MM)
843-193-2801-009	9	.450	(11,43)	.400 ± .007	(10,16 ± 0,18)
843-193-2801-010	10	.500	(12,70)	.450 ± .007	(11,43 ± 0,18)
843-193-2801-014	14	.700	(17,78)	.650 ± .007	(16,51 ± 0,18)
843-193-2801-015	15	.750	(19,05)	.700 ± .007	(17,78 ± 0,18)
843-193-2801-016	16	.800	(20,32)	.750 ± .011	(19,05 ± 0,28)
843-193-2801-020	20	1.000	(25,40)	.950 ± .011	(24,13 ± 0,28)
843-193-2801-024	24	1.200	(30,48)	1.150 ± .011	(29,21 ± 0,28)
843-193-2801-025	25	1.250	(31,75)	1.200 ± .011	(30,48 ± 0,28)
843-193-2801-026	26	1.300	(33,02)	1.250 ± .011	(31,75 ± 0,28)
843-193-2801-034	34	1.700	(43,18)	1.650 ± .011	(41,91 ± 0,28)
843-193-2801-036	36	1.800	(45,72)	1.750 ± .015	(44,45 ± 0,38)
843-193-2801-037	37	1.850	(47,00)	1.800 ± .015	(45,72 ± 0,38)
843-193-2801-040	40	2.000	(50,80)	1.950 ± .015	(49,53 ± 0,38)
843-193-2801-050	50	2.500	(63,50)	2.450 ± .015	(62,23 ± 0,38)
843-193-2801-060	60	3.000	(76,20)	2.950 ± .015	(74,93 ± 0,38)
843-193-2801-064	64	3.200	(81,28)	3.150 ± .015	(80,01 ± 0,38)

### benefits

- Wide range of operating temperatures - 65°C to +125°C
- Fast signal speed
- Low capacitance
- UL recognized (UL style no. 20559)

### characteristics

#### Physical

*Conductors:* 28-7/36 AWG Tinned Copper  
*Insulation:* Extruded TPE, .010" wall  
*Color:* Tan (one edge red)  
*Temperature Rating:*  
 -65 to 125°C (-85°F to 257°F)  
*UL Style:* 20559 (125°C, 300 volts)

#### Electrical

*Impedance:* 115 ohms  
*Propagation Delay:* 1.35 ns/ft  
*Capacitance at 1 MHz:* 11.0 pF/ft  
*Inductance at 1 MHz:* .18 uH/ft  
*Insulation Resistance:*  
 10<sup>10</sup> ohms -10 ft. (min)  
*Unbalanced CrossTalk:*  
 5 ns Risetime (10 ft sample), 2 lines driven  
 Near End: 3.0% Far End: 3.0%  
*Note:* ground-signal-ground test mode

### options

- Available with 28-19 AWG stranded conductors on .050" centers for high flex life applications.
- Also available with .025" conductor spacing.
- 193-2811 Series  
28-7/36 105°C TPE
- Consult factory for details.

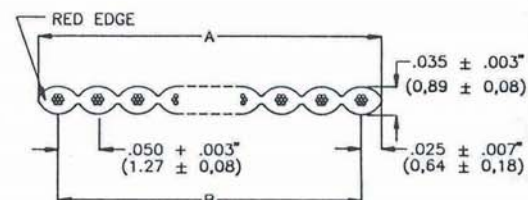

Dimensions and characteristics subject to change without notice.



# Spectra-Zip® PVC .025" center cable 191-3X0X series

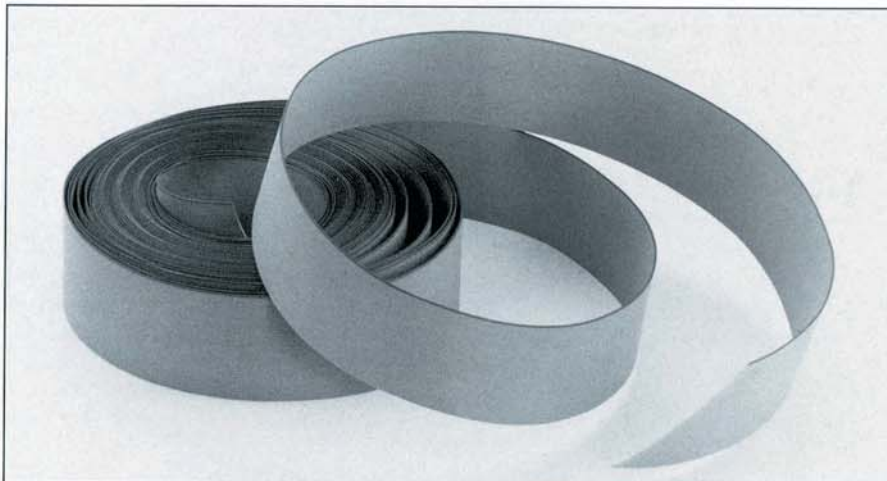

## characteristics

### physical

Conductors: copper, see chart below  
 Insulation: .0075" (0,19mm) wall PVC  
 Pitch: 0.025"±0.002" (0,64±0,05 mm) centers  
 Color: gray (one edge black)  
 Temperature rating: -20°C to +105°C (-4°F to +221°F)

### electrical

Voltage: 150 V  
 Current rating: 0.8 amps nominal @ 10°C rise above ambient  
 Propagation delay: 1.60 ns/ft (5,25 ns/m) nominal  
 Insulation resistance: 10<sup>10</sup> ohms - 10' (3 m) min.  
 Crosstalk: 10' (3 m) sample, 5 ns rise time with 2 lines driven, unbalanced mode (see below)  
**UL style: #2678, rated 105°C (+221°F)**

## description

Spectra-Strip® PVC .025" center zip cable is designed to meet industry requirements for interconnect miniaturization. Applications include any system requiring a higher signal density or an inexpensive alternative to transmission cable. Standard put-up is 100' coils. Longer lengths are available upon request.

## benefits

- High density center-to-center spacing allows increased miniaturization
- Precise spacing for controlled electrical characteristics
- Easy, fast mass-termination
- Easy identification of # 1 conductor with edge mark
- Double contour allows termination from either side of cable
- UL recognized

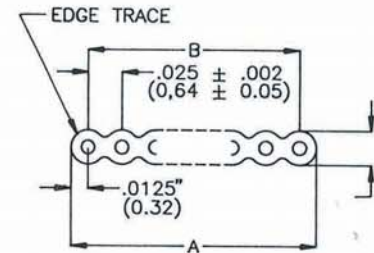

Part Number	191-3003	191-3005	191-3203	191-3205
Conductors	30-1 solid bare	30-7/38 tinned	32-1 solid bare	32-7/40 tinned
Thickness	.025"±.002"	.027"±.002"	.023"±.002"	.024"±.002"
Impedance	80 ohms	70 ohms	95 ohms	90 ohms
Capacitance (nominal)	19.0 pf/ft (62,3 pf/m) @ 1 MHz	25.0 pf/ft (82,0 pf/m) @ 1 MHz	18.0 pf/ft (59,06 pf/m) @ 1 MHz	18.0 pf/ft (59,06 pf/m) @ 1 MHz
Inductance (nominal)	.15 µh/ft (.49 µh/m) @ 1.0 MHz	.14 µh/ft (.46 µh/m) @ 1.0 MHz	.17 µh/ft (.56 µh/m) @ 1.0 MHz	.16 µh/ft (.52 µh/m) @ 1.0 MHz
Crosstalk	near end: * 2.6% far end: * 3.7%	near end: * 2.6% far end: * 3.7%	near end: * 2.6% far end: * 3.7%	near end: * 2.6% far end: * 3.7%
**ground-ground-signal	near end: ** 1.0%	near end: ** 1.0%	near end: ** 1.0%	near end: ** 1.0%
-ground-ground	far end: ** 2.0%	far end: ** 2.0%	far end: ** 2.0%	far end: ** 2.0%

## order information

30-1 BARE SOLID PART #	30-7/38 TINNED PART #	32-1 BARE SOLID PART #	32-7/40 TINNED PART #	# COND	WIDTH A		SPAN B	
					INCHES	(mm)	INCHES	(mm)
191-3003-010	191-3005-010	191-3203-010	191-3205-010	10	.250	(6,35)	.225±.005	(5,72±0,13)
191-3003-016	191-3005-016	191-3203-016	191-3205-016	16	.400	(10,16)	.375±.005	(9,53±0,13)
191-3003-020	191-3005-020	191-3203-020	191-3205-020	20	.500	(12,70)	.475±.005	(12,07±0,13)
191-3003-026	191-3005-026	191-3203-026	191-3205-026	26	.650	(16,51)	.625±.005	(15,88±0,13)
191-3003-034	191-3005-034	191-3203-034	191-3205-034	34	.850	(21,59)	.825±.006	(20,96±0,15)
191-3003-040	191-3005-040	191-3203-040	191-3205-040	40	1.000	(25,40)	.975±.006	(24,77±0,15)
191-3003-050	191-3005-050	191-3203-050	191-3205-050	50	1.250	(31,75)	1.225±.006	(31,12±0,15)
191-3003-060	191-3005-060	191-3203-060	191-3205-060	60	1.500	(38,10)	1.475±.006	(37,47±0,15)
191-3003-064	191-3005-064	191-3203-064	191-3205-064	64	1.600	(40,64)	1.575±.006	(40,01±0,15)
191-3003-068	191-3005-068	191-3203-068	191-3205-068	68	1.700	(43,18)	1.675±.007	(42,55±0,18)
191-3003-080	191-3005-080	191-3203-080	191-3205-080	80	2.000	(50,80)	1.975±.007	(50,17±0,18)
191-3003-100	191-3005-100	191-3203-100	191-3205-100	100	2.500	(63,50)	2.475±.007	(62,87±0,18)



# Spectra-Zip® TPE .025" center 193-3X0X series

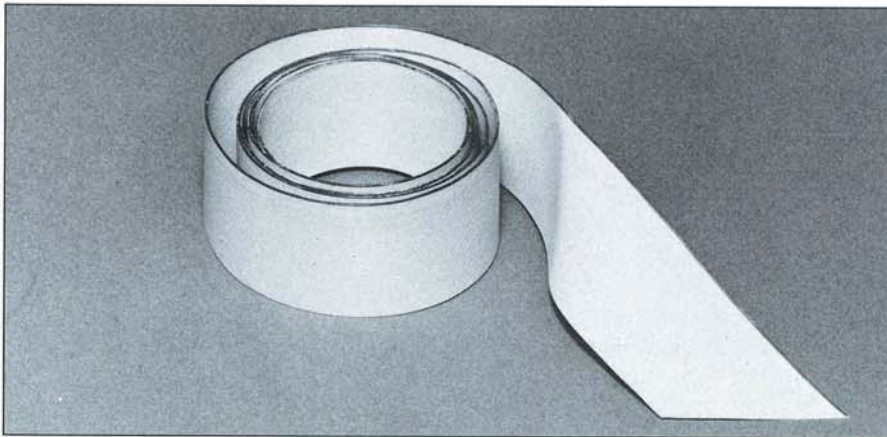

## characteristics

### physical

*Conductors:* copper, see chart below  
*Insulation:* .0075" (0,19mm) wall TPE  
*Pitch:* 0.025"±0.002" (0,64±0,05mm) centers  
*Color:* gray (one edge red)  
*Temperature rating:* -20°C to +105°C (-4°F to +221°F)

### electrical

*Voltage:* 150 V  
*Current rating:* 0.8 amps nominal @ 10°C rise above ambient  
*Propagation delay:* 1.45 ns/ft (4,76 ns/m) nominal  
*Insulation resistance:* 10<sup>10</sup> ohms - 10' (3 m) min.  
*Crosstalk:* 10' (3 m) sample, 5 ns rise time with 2 lines driven, unbalanced mode (see chart below)  
**UL style: #20647, rated 105°C (+221°F)**

## description

Spectra-Strip® TPE .025" center zip cable accommodates interconnect miniaturization, with the added benefit of improved electrical performance characteristics. Applications include any system requiring higher and faster signal density. Standard put-up is 100' coils. Longer lengths are available upon request.

## benefits

- TPE insulation - lower dielectric constant, higher impedance, and faster signal speeds than PVC cable
- High density center-to-center spacing allows increased miniaturization
- Precise spacing for controlled electrical characteristics
- Easy, fast mass-termination
- Easy identification of # 1 conductor with edge mark
- Double contour allows termination from either side of cable
- UL recognized

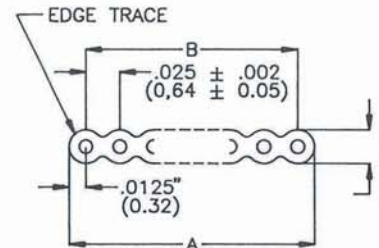

Part Number	193-3003	193-3005	193-3203	193-3205
<b>Conductors</b>	30-1 solid bare	30-7/38 tinned	32-1 solid bare	32-7/40 tinned
<b>Thickness</b>	.025"±.002"	.027"±.002"	.023"±.002"	.024"±.002"
<b>Impedance</b>	88 ohms	80 ohms	105 ohms	95 ohms
<b>Capacitance (nominal)</b>	16.5 pf/ft (54,1 pf/m) @ 1 MHz	19.0 pf/ft (62,3 pf/m) @ 1 MHz	14.0 pf/ft (45,9 pf/m) @ 1 MHz	17.0 pf/ft (55,8 pf/m) @ 1 MHz
<b>Inductance (nominal)</b>	.15 µh/ft (.49 µh/m) @ 1.0 MHz	.14 µh/ft (.46 µh/m) @ 1.0 MHz	.17 µh/ft (.56 µh/m) @ 1.0 MHz	.15 µh/ft (.49 µh/m) @ 1.0 MHz
<b>Crosstalk</b>	near end: * 2.7% far end: * 3.3%	near end: * 3.1% far end: * 3.6%	near end: * 3.0% far end: * 3.6%	near end: * 3.1% far end: * 3.4%
**ground-signal-ground	near end: ** 1.0% far end: ** 1.6%	near end: ** 1.0% far end: ** 1.9%	near end: ** 1.2% far end: ** 2.2%	near end: ** 1.0% far end: ** 2.0%

## order information

30-1 BARE SOLID	30-7/38 TINNED	32-1 BARE SOLID	32-7/40 TINNED	# COND	WIDTH A		SPAN B	
					INCHES	(mm)	INCHES	(mm)
193-3003-010	193-3005-010	193-3203-010	193-3205-010	10	.250	(6,35)	.225±.005	(5,72±0,13)
193-3003-016	193-3005-016	193-3203-016	193-3205-016	16	.400	(10,16)	.375±.005	(9,53±0,13)
193-3003-020	193-3005-020	193-3203-020	193-3205-020	20	.500	(12,70)	.475±.005	(12,07±0,13)
193-3003-026	193-3005-026	193-3203-026	193-3205-026	26	.650	(16,51)	.625±.005	(15,88±0,13)
193-3003-034	193-3005-034	193-3203-034	193-3205-034	34	.850	(21,59)	.825±.006	(20,96±0,15)
193-3003-040	193-3005-040	193-3203-040	193-3205-040	40	1.000	(25,40)	.975±.006	(24,77±0,15)
193-3003-050	193-3005-050	193-3203-050	193-3205-050	50	1.250	(31,75)	1.225±.006	(31,12±0,15)
193-3003-060	193-3005-060	193-3203-060	193-3205-060	60	1.500	(38,10)	1.475±.006	(37,47±0,15)
193-3003-064	193-3005-064	193-3203-064	193-3205-064	64	1.600	(40,64)	1.575±.006	(40,01±0,15)
193-3003-068	193-3005-068	193-3203-068	193-3205-068	68	1.700	(43,18)	1.675±.007	(42,55±0,18)
193-3003-080	193-3005-080	193-3203-080	193-3205-080	80	2.000	(50,80)	1.975±.007	(50,17±0,18)
193-3003-100	193-3005-100	193-3203-100	193-3205-100	100	2.500	(63,50)	2.475±.007	(62,87±0,18)

# Spectra-Strip® Ultra ATA Cable

## 191-3003-080 (PVC 30 awg solid)

## 191-3005-080 (PVC 30 awg stranded)

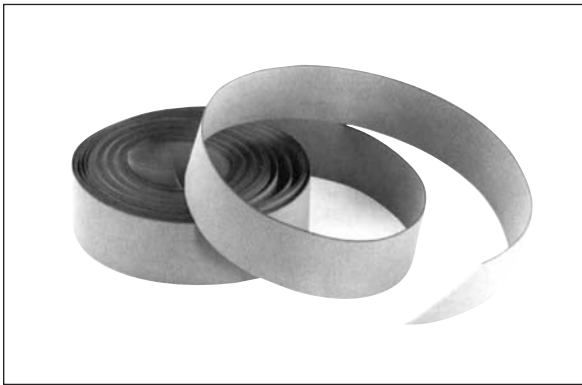

Spectra-Strip's new 80 conductor Ultra ATA is offered in two versions as recommended by the SFF-8049 committee for reliable 66 Mb/sec ATA data cable transfer

for cable assemblies up to 18.0". TPE cables with higher impedance are available for longer cables (consult factory for details).

### Benefits

- High density spacing allows increased miniaturization
- Precise spacing for controlled electrical characteristics
- Easy, fast mass termination
- Double contour allows termination from either side of cable
- UL recognized/CSA certified

### Physical characteristics

Conductors: (80) 30-1 bare copper (191-3003-080) or (80) 30- 7/38 tinned copper (191-3005-080)  
 Insulation: PVC  
 Color: Gray, with edge trace for polarity  
 Conductor Spacing: .025" ± 0.002"  
 Temperature Rating: -20° C to + 105° C

### Order Information

Series 191-3003-080  
 Series 191-3005-080

Part Number	No. Cond.		Width A (Nominal)		Span B	
			Inches	(mm)	Inches	(mm)
191-3003-080	80	30-1 Bare	2.000	(50,80)	1.975 ±.007	(50,17) ±0,18
191-3005-080	80	30 7/38 Tinned	2.000	(50,80)	1.975 ±.007	(50,17) ±0,18

Dimensions and characteristics subject to change without notice.

### Electrical

Impedance (GSG)  
 Capacitance  
 UL  
 Flammability  
 Voltage Rating

### 191-3003-080

80 ohms  
 19.0 pf/ft  
 Style 2678  
 VW1/FT1  
 150 V

### 191-3005-080

70 ohms  
 25.0 pf/ft  
 Style 2678  
 VW1/FT1  
 150 V

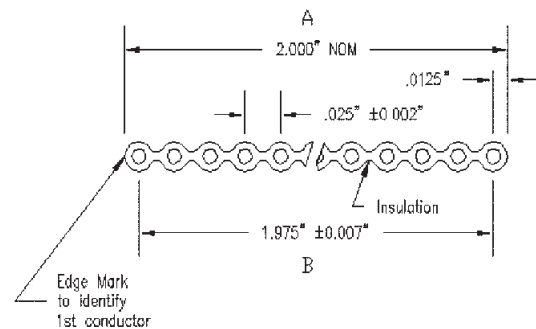



# Spectra-Strip® SCA Cable 193-3099-986



Spectra-Strip's new 80 conductor cable, P/N 193-3099-986 is designed for use with the SCA-2 (Single Connector Attach) as defined by the Small Form Factor (SFF) committee and EIA. Applications include daisy chained

SCSI adapter cables that carry additional power and auxiliary signals. The cable is the same as standard Fast 20/40 P/N 193-3099-988 with the exception of 12 additional conductors.

### Benefits

- Compliance with single ended and differential SCSI standards
- Significant cost savings vs. FEP dielectric
- Precision pitch and span control for termination with automatic machines

### Physical characteristics

Conductors: (80) 30AWG solid bare copper  
 Insulation: Thermoplastic Elastomer (TPE)  
 Color Code: White with edge trace for polarity  
 Conductor Spacing: .025" ± .002"  
 Temperature Rating: -65°C to + 105°C

### Electrical

Impedance: 90 ohms ± 6 ohms, single ended, SCSI mode  
 125 ± 10 ohms, differential  
 Capacitance: 16.4 pf/ft @ 1 MHZ, single ended  
 11.7 pf/ft @ 1 MHZ, differentially  
 Propagation Delay: 1.43 ns/ft nom  
 Propagation Delay Skew: .025 ns/ft max  
 Voltage Rating: 150 V

### UL / CSA

UL VW1 CSA FT 1  
 UL Style 20297

### Order Information

Part Number	No. Cond.	30-1 Bare	Width A (Nominal)		Span B	
			Inches	(mm)	Inches	(mm)
193-3099-986	80	30-1 Bare	1.995	(50,80)	1.975 ±.007	(50,17) ±0,18

Dimensions and characteristics subject to change without notice.

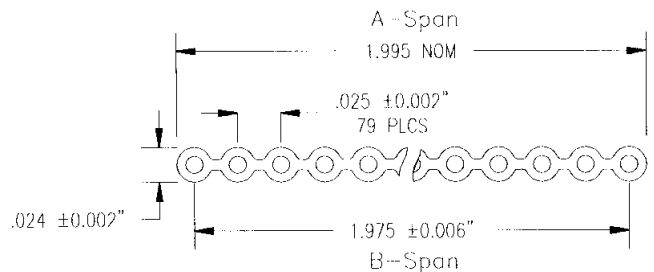

# Spectra-Strip® fast 20/40 SCSI Cable

## 193-3099-988 series



Spectra-Strip's new Fast 20/40 SCSI cable is designed to comply with the recently released ANSI standard for Fast 20 SCSI devices operating at 20 MB data rates. Two versions of the cable are offered: 50 conductor 26 AWG on .050" centers PVC for 8 bit narrow applications (see part number 191-2601-150), and 68 conductor

30 AWG on .025" centers for 16 and 32 bit wide applications (part number 193-3099-988).

With the new cable, characteristic impedance is higher (and tighter) at  $90 \pm 6$  ohms and signal-to-signal skew is controlled to within .036 ns/ft max, to accommodate the higher frequency fast 20 signals.

### Benefits

- Allows Implementors of the New Fast 20/40 SCSI (also known as Ultra SCSI) to Double SCSI 3's Data RATE to 20 or 40 Megabytes
- Full Compatibility with Existing SCSI Connectors
- Improved Signal Shape and Timing

### Physical characteristics

Conductors: (68) 30-1 bare copper

Insulation: Polyolefin

Color Code: White, one edge mark for polarity

Conductor Spacing:  $.025" \pm .002"$

### Electrical

Impedance:  $90 \pm 6$  ohms

Capacitance: 14.1 pf/ft @ 1 MHZ

Propagation Delay: 1.34 ns/ft

Propagation Delay Skew: .036 ns/ft max

DC Resistance: 104 ohms/1,000' - 10' minimum

*Above values measured in the ground-signal-ground configuration*

### Order Information

Series 193-3099-988 30-1, .25" centers

Part Number	No. Cond.	Width A (Nominal)		Span B	
		Inches	(mm)	Inches	(mm)
193-3099-988	68	1.695	(43,18)	1.675 $\pm$ .006	(42.541 $\pm$ 0.15)

Dimensions and characteristics subject to change without notice.

Standard put-up is 100 feet on cardboard reels. Consult factory for larger put-ups.

### UL Recognized CSA AWM FT-1

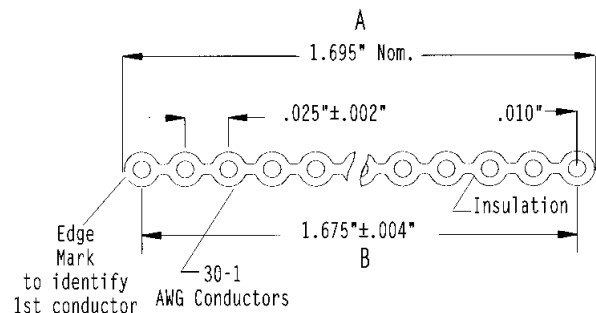



# Spectra-Strip® .025" loose pair twist 'n'flat® 425-3006 series

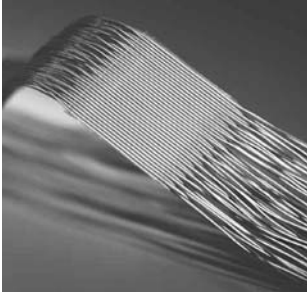

### Benefits

For internal single-ended or differential SCSI applications requiring twisted pairs, Spectra-Strip now offers mass termination on .025" centers with its new .025" Twist 'N' Flat®. Unique in the industry, this is the only cable to offer programmable twist length sections (up to a maximum of 10) and loose, unbonded twisted pairs for a maximum in cable flexibility and improved airflow within the cabinet. Compared with traditional hand lamination methods, .025" Twist 'N' Flat® affords considerable end product cost savings.

- Offers reduced total assembly costs over current labor-intensive discrete or hand-lamination methods.
- Up to ten twist length combinations are available.
- Loose pairs between IDC flats allows increased airflow around the assembly.
- Terminates to industry standard .025" IDC connectors.
- Double-sided lamination provides excellent conductor strain relief.

### Order Information

Series 425-3006-OXX 30-7/38, .025" centers

Part Number	No. Cond.	No. Pairs	Width 'A' (Nominal)		Span 'B'	
			Inches	(mm)	Inches	(mm)
425-3006-010	10	5	0.257	(6,53)	0.225±.010	(5,72±0,25)
425-3006-014	14	7	0.357	(9,07)	0.325±.010	(8,26±0,25)
425-3006-016	16	8	0.407	(10,34)	0.375±.010	(9,53±0,25)
425-3006-020	20	10	0.507	(12,88)	0.475±.010	(12,07±0,25)
425-3006-026	26	13	0.657	(16,69)	0.625±.010	(15,88±0,25)
425-3006-034	34	17	0.857	(21,77)	0.825±.010	(20,96±0,25)
425-3006-036	36	18	0.907	(23,04)	0.875±.010	(22,23±0,25)
425-3006-040	40	20	1.007	(25,58)	0.975±.010	(24,77±0,25)
425-3006-050	50	25	1.257	(31,93)	1.225±.010	(31,12±0,25)
425-3006-060	60	30	1.507	(38,28)	1.475±.010	(37,47±0,25)
425-3006-064	64	32	1.607	(40,82)	1.575±.010	(40,01±0,25)
425-3006-068	68	34	1.707	(43,36)	1.675±.010	(42,55±0,25)
425-3006-080	80	40	2.007	(50,98)	1.975±.010	(50,17±0,25)
425-3006-100	100	50	2.507	(63,68)	2.475±.010	(62,87±0,25)

Halogen-Free versions now available: 425-3016-XXX

- UL
- CSA Certified

### Physical characteristics

Conductors: 30 AWG 7/38 Strand, Tinned Copper  
 Insulation: .006" PVC  
 Color Code: 1st Pair Red/Gray Followed by Blue/Gray and Repeat  
 Laminate: Polyester  
 Temperature Rating: 80°C  
 UL Style #20744 CSA AWM FT-1

### Electrical

Impedance: 110 ohms<sup>1</sup> 95 ohms<sup>2</sup> 120 ohms<sup>3</sup>  
 Capacitance: 13 pf/ft<sup>1</sup> 18 pf/ft<sup>2</sup> 13 pf/ft<sup>3</sup>  
 Propagation Delay: 1.5 ns/ft  
 Voltage Rating: 150 volts  
 Current Rating: 0.75 amp  
 DC Resistance: 106 ohm/1,000'  
 Attenuation (5 MHz): 4 dB/100'  
 Attenuation (10 MHz): 5 dB/100'

- 1 Measured Single-Ended
- 2 Measured Single-Ended with One Conductor of Each Pair Commoned to One Bus (SCSI mode)
- 3 Measured Differentially

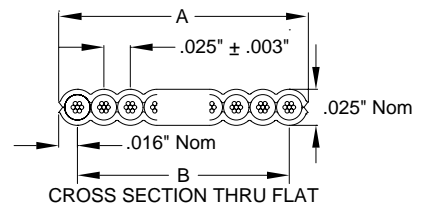
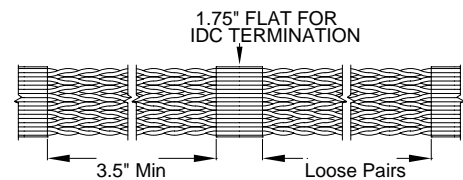

# Spectra-Strip® .025" full lamination twist 'n' flat® 125-3001 series (PVC 30 AWG, Solid)

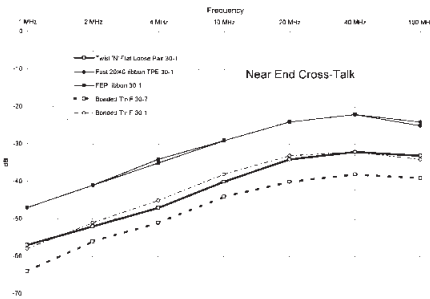
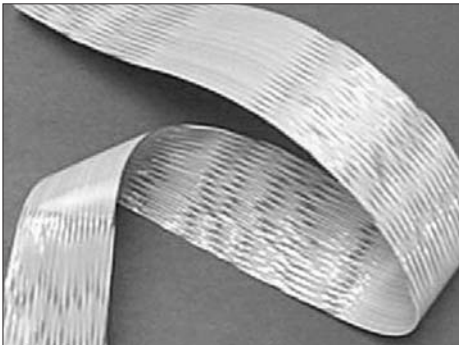

For internal single-ended or LVD SCSI applications Spectra-Strip now offers significantly reduced crosstalk and mass termination with its new .025" pitch **fully laminated** Twist'N'Flat®. Unique in the industry, this is the only cable to offer programmable twist length sections and a fully laminated construction for improved signal fidelity and greater crosstalk control on all pairs. Compared with traditional hand lamination methods of terminating SCSI cables, Twist'N'Flat affords considerable end product cost savings.

### Benefits

- UL / CSA certified
- Recommended for LVD SCSI higher frequency applications
- Twisted pairs for significant crosstalk isolation
- Fully laminated construction for tighter impedance control
- Up to ten twist length combinations available
- Reduced assembly costs compared with discrete or hand lamination terminations

### Physical characteristics

Conductors: 30 AWG Solid, Tinned Copper  
 Insulation: .007" PVC  
 Color Code: 1st Pair Red/White followed by Tan/White and Repeat  
 Laminate: Polyester  
 Temperature Rating: 80° C  
 UL Style #20744 CSA AWM FT-1

### Electrical

Impedance: 90 ohms, single ended  
 115 ohms, differential  
 Capacitance: 19.2 pf/ft,@ 1 MHZ, single ended  
 14.8 pf/ft,@ 1 MHZ, differentially  
 Propagation Delay: 1.59 ns/ft  
 Voltage Rating: 150 volts  
 Current Rating: 0.75 amp  
 DC Resistance: 105 ohm/1,000'  
 Delay Skew: .035 ns/ft max

### Order Information

Series 125-3001-0XX 30-1 .025" centers

Part Number	No. Cond.	No. Pairs	Width A (Nominal)		Span B	
			Inches	(mm)	Inches	(mm)
125-3001-010	10	5	0.257	(6,53)	0.225±.010	(5,72±0,25)
125-3001-014	14	7	0.357	(9,07)	0.325±.010	(8,26±0,25)
125-3001-016	16	8	0.407	(10,34)	0.375±.010	(9,53±0,25)
125-3001-020	20	10	0.507	(12,88)	0.475±.010	(12,07±0,25)
125-3001-026	26	13	0.657	(16,69)	0.625±.010	(15,88±0,25)
125-3001-034	34	17	0.857	(21,77)	0.825±.010	(20,96±0,25)
125-3001-036	36	18	0.907	(23,04)	0.875±.010	(22,23±0,25)
125-3001-040	40	20	1.007	(25,58)	0.975±.010	(24,77±0,25)
125-3001-050	50	25	1.257	(31,93)	1.225±.010	(31,12±0,25)
125-3001-060	60	30	1.507	(38,28)	1.475±.010	(37,47±0,25)
125-3001-064	64	32	1.607	(40,82)	1.575±.010	(40,01±0,25)
125-3001-068	68	34	1.707	(43,36)	1.675±.010	(42,55±0,25)
125-3001-080	80	40	2.007	(50,98)	1.975±.010	(50,17±0,25)
125-3001-100	100	50	2.507	(63,68)	2.475±.010	(62,87±0,25)

Stranded version available 125-3007-XXX

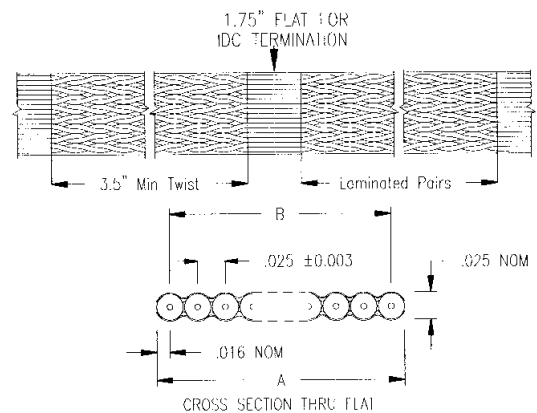



# Spectra-Strip® .025" full lamination twist 'n' flat® 125-3007 series (PVC 30 AWG, Stranded)

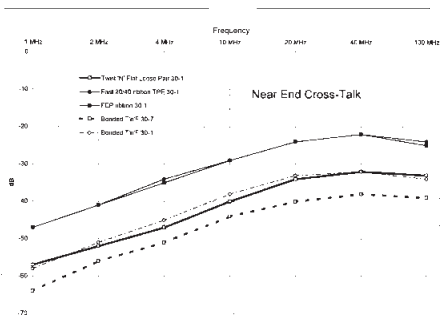
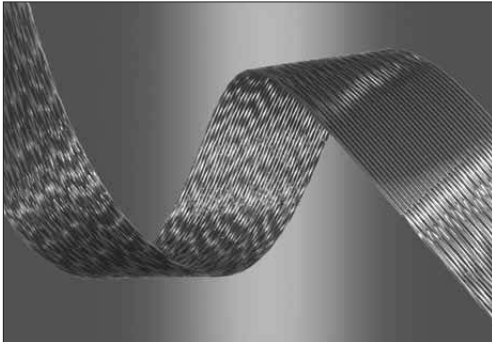

For internal single-ended or LVD SCSI applications Spectra-Strip now offers significantly reduced crosstalk and mass termination with its new .025" pitch **fully laminated** Twist'N'Flat®. Unique in the industry, this is the only cable to offer programmable twist length sections and a fully laminated construction for improved signal fidelity and greater crosstalk control on all pairs. Compared with traditional hand lamination methods of terminating SCSI cables, Twist'N'Flat affords considerable end product cost savings.

### Benefits

- UL / CSA certified
- Recommended for LVD SCSI higher frequency applications
- Twisted pairs for significant crosstalk isolation
- Fully laminated construction for tighter impedance control
- Up to ten twist length combinations available
- Reduced assembly costs compared with discrete or hand lamination terminations

### Physical characteristics

Conductors: 30 AWG 7/38 stranded, Tinned Copper  
 Insulation: .006" PVC  
 Color Code: 1st Pair Red/Gray followed by Blue/Gray and Repeat  
 Laminate: Polyester  
 Temperature Rating: 80° C  
 UL Style #20744 CSA AWM FT-1

### Electrical

Impedance: 80 ohms, single ended  
 110 ohms, differential  
 Capacitance: 20.3 pf/ft, @ 1 MHZ, single ended  
 15.9 pf/ft, @ 1 MHZ, differentially  
 Propagation Delay: 1.59 ns/ft  
 Voltage Rating: 150 volts  
 Current Rating: 0.75 amp  
 DC Resistance: 95 ohm/1,000'  
 Delay Skew: .035 ns/ft max

### Order Information

Series 125-3007-OXX 30-7/38, .025" centers

Part Number	No. Cond.	No. Pairs	Width A (Nominal)		Span B	
			Inches	(mm)	Inches	(mm)
125-3007-010	10	5	0.257	(6,53)	0.225±.010	(5,72±0,25)
125-3007-014	14	7	0.357	(9,07)	0.325±.010	(8,26±0,25)
125-3007-016	16	8	0.407	(10,34)	0.375±.010	(9,53±0,25)
125-3007-020	20	10	0.507	(12,88)	0.475±.010	(12,07±0,25)
125-3007-026	26	13	0.657	(16,69)	0.625±.010	(15,88±0,25)
125-3007-034	34	17	0.857	(21,77)	0.825±.010	(20,96±0,25)
125-3007-036	36	18	0.907	(23,04)	0.875±.010	(22,23±0,25)
125-3007-040	40	20	1.007	(25,58)	0.975±.010	(24,77±0,25)
125-3007-050	50	25	1.257	(31,93)	1.225±.010	(31,12±0,25)
125-3007-060	60	30	1.507	(38,28)	1.475±.010	(37,47±0,25)
125-3007-064	64	32	1.607	(40,82)	1.575±.010	(40,01±0,25)
125-3007-068	68	34	1.707	(43,36)	1.675±.010	(42,55±0,25)
125-3007-080	80	40	2.007	(50,98)	1.975±.010	(50,17±0,25)
125-3007-100	100	50	2.507	(63,68)	2.475±.010	(62,87±0,25)

Solid version available 125-3001-XXX

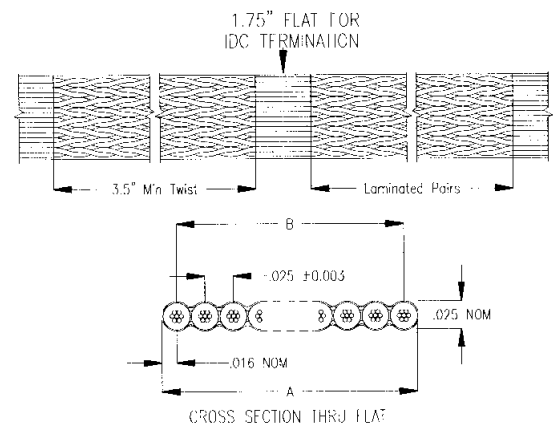

# .025" Pitch Spectra-Mode™ Twist 'N' Flat®, 30 AWG Solid Tinned Copper, TPE Insulation 125-3011-XXX

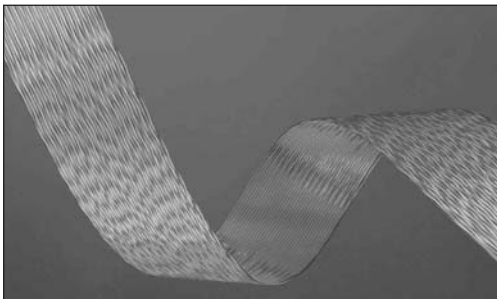

Spectra-Strip now has the first truly "multi-mode" internal wide SCSI cable available that fully meets ANSI T10/1142 D impedance requirements for both Ultra 2 LVD (Low Voltage Differential) and Fast 20 single ended applications with one cable. Called "Spectra-Mode™", it is the latest generation of Twist 'N' Flat®, having a characteristic impedance of 93 ohms (single ended) and 131 ohms (differential). This dual mode cable allows SCSI designers to ensure

that their Ultra 2 LVD busses operate correctly when a Fast 20 single ended device is attached to the bus, and the system defaults to Fast 20 mode. Unique in the industry, this is the only cable to offer programmable twist length sections and a fully laminated construction for improved signal fidelity and greater crosstalk control on all pairs. Compared with traditional hand lamination methods of terminating SCSI cables, Twist 'N' Flat® affords considerable end product cost savings.

## Features/Benefits

- Recommended for both Ultra 2 LVD and Fast 20 SCSI higher frequency applications
- Twisted pairs for significant crosstalk isolation
- Fully laminated construction for tighter impedance control
- Up to ten twist length combinations available
- Double sided lamination provides excellent conductor strain relief
- Reduced assembly costs compared with discrete or hand lamination terminations

## Physical

**Conductors:** 30 awg solid tinned copper  
**Color:** 1st pair blue / white, followed by orange / white and repeat  
**Insulation:** .007 TPE  
**Laminate:** Fully laminated Polyester, top and bottom  
**Temperature Rating:** 80°C  
**UL Style:** 20744  
**CSA/FT1**

## Electrical

**Impedance:** 93 ohms single ended  
 131 ohms differential  
**Capacitance:** 15.3pF / ft @ 1 MHz, single ended  
 11.4 pF / ft @ 1 MHz, differential  
**Propagation Delay:** 1.45 NS / ft nom  
**Voltage Rating:** 150 volts  
**Current Rating:** .75 amp  
**Delay Skew:** .035 ns / ft max  
**Crosstalk:** see chart

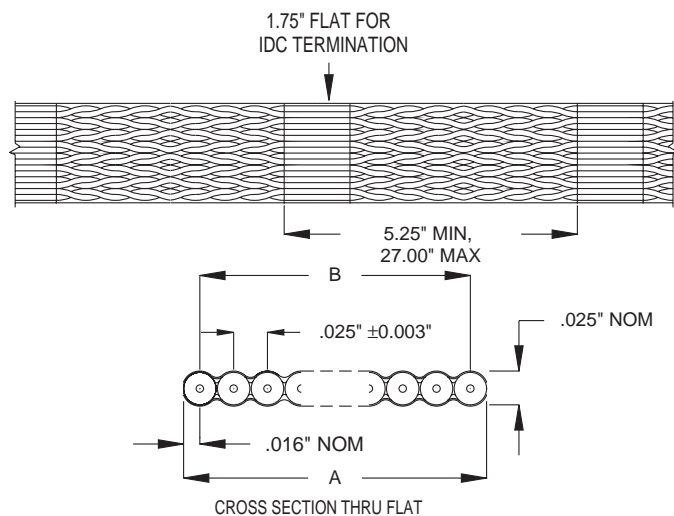
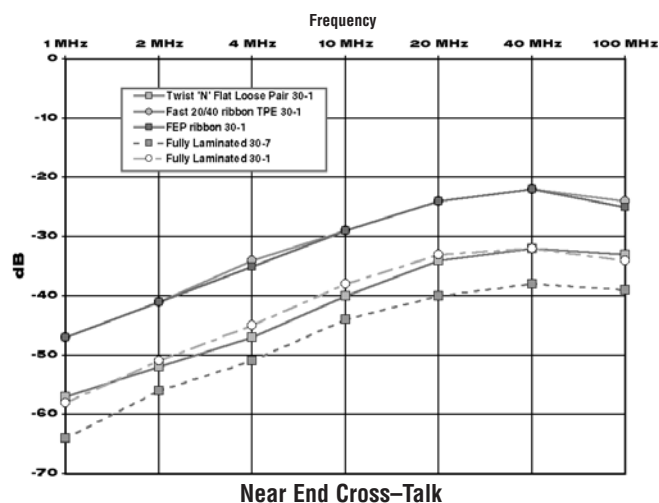

## Ordering Information

XXX=s unique part number for flat section center to center dimension

Part Number	No. Cond.	No. Pairs	Width 'A'		Span 'B'	
			Inches	(mm)	Inches	(mm)
125-3011-XXX	68	34	1.707	(43,36)	1.675±010	(42,55±0,25)



# Spectra-GP® .025" center ground plane planar cable 133-301X series

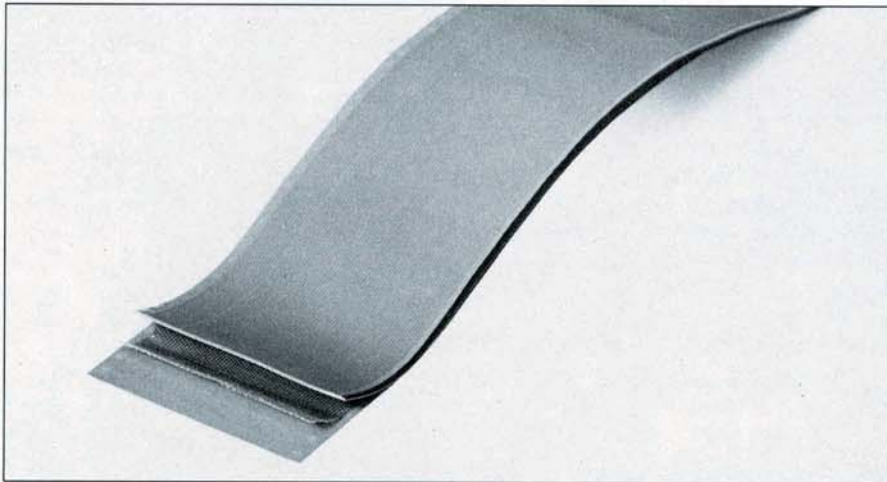

## characteristics physical

**Conductors and drain wire:** 30 AWG solid copper conductors, 30-7/38 AWG tinned copper drain wire  
**Ground plane:** expanded copper mesh .005" (0,13mm) thick  
**Laminate:** .0123" (0,31mm) gray PVC  
**Thickness:** .045" (1,27mm) nom.  
**Pitch:** .025 ± .002" (0,64±0,08mm) centers  
**Color:** gray  
**Edge mark:** red: (no drain wire)  
 black: (drain wire in #1 position)

## electrical

**Voltage:** 300 V  
**Current rating:** 0.8 amp nominal @ 10°C above ambient  
**Temperature rating:** -20°C to +105°C (-4°F to 221°F)  
**Impedance:** 65 ohms nominal\*  
**Capacitance:** 30.0 pf/ft. (98,43 pf/m) nominal @ 1.0 MHz\*  
**Inductance:** .14 µh/ft. (.46 µh/m) nominal @ 1.0 MHz\*  
**Propagation delay:** 1.65 ns/ft. (5,41 ns/m) nominal  
**Insulation resistance:** 10<sup>10</sup> ohms - 10 ft. (3 m) min.  
**Unbalanced crosstalk:** 10' sample, 5 ns rise time with 2 lines driven, near end = 1.1% nominal far end = 2.3% nominal  
 \* Measured from conductor to ground plane  
**UL: #2682 105°C, 300 volts**

## description

Spectra-GP® .025" Ground Plane Cable is especially suited to applications in computer and communications equipment for data transmission and switching, where reduced cross-talk is necessary. Ground plane cable consists of stranded uninsulated conductors laminated between PVC film. The ground plane consists of expanded copper mesh, laminated at a controlled distance from the conductors, and enclosed with an outer layer of PVC film. Ground plane cable is available with or without a drain wire.

## benefits

- interconnect miniaturization to .025" centers
- Integrally laminated ground plane reduces cross-talk
- Mass terminable
- Put-up in convenient 100' coils
- Custom capabilities available: Single or multiple drain wires, in any position
- UL recognized 

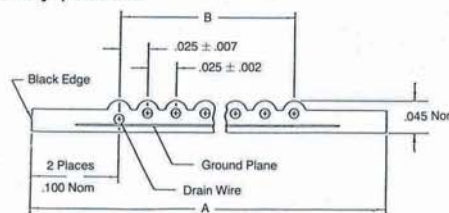

## order information

E-Z PEEL GP W/ DRAIN WIRE PART #	E-Z PEEL GP W/O DRAIN WIRE PART #	# COND	WIDTH A		SPAN B	
			INCHES	(mm)	INCHES	(mm)
133-3014-010	133-3013-010	10	.425	(10,80)	.225±.005	(5,72±13)
133-3014-016	133-3013-016	16	.575	(14,61)	.375±.005	(9,53±0,13)
133-3014-020	133-3013-020	20	.675	(17,15)	.475±.005	(12,07±0,13)
133-3014-026	133-3013-026	26	.825	(20,96)	.625±.005	(15,88±0,13)
133-3014-034	133-3013-034	34	1.025	(26,04)	.825±.005	(20,96±0,13)
133-3014-040	133-3013-040	40	1.175	(29,85)	.975±.006	(24,77±0,15)
133-3014-050	133-3013-050	50	1.425	(36,20)	1.225±.006	(31,12±0,15)
133-3014-060	133-3013-060	60	1.675	(42,55)	1.475±.006	(37,47±0,15)
133-3014-064	133-3013-064	64	1.775	(45,09)	1.575±.006	(40,01±0,15)
133-3014-080	133-3013-080	80	2.175	(55,25)	1.975±.006	(50,17±0,15)
133-3014-100	133-3013-100	100	2.475	(62,87)	2.475±.007	(62,87±0,18)



# Spectra-Zip® .025" center shielded & jacketed planar cable 151-3033-XXX series



## description

Spectra-Zip® Jacketed & Shielded Cable is well-suited to applications such as external interconnect applications that require EMI/ RFI considerations. The cable is jacketed in rugged extruded black PVC - Spectra-Guard®, which provides excellent abrasion resistance. Shielding consists of aluminum/poly, with optional drain wires, making it ideal for high-speed data processing equipment and high frequency communications systems.

## benefits

- Rugged, flexible protection
- Excellent crosstalk and electrical performance
- High density center-to-center spacing allows increased miniaturization
- Shielding reduces cross-talk
- Precise spacing for controlled electrical characteristics
- Mass terminable
- Put-up in convenient 100' coils
- Easy to identify #1 conductor with edge mark
- UL recognized

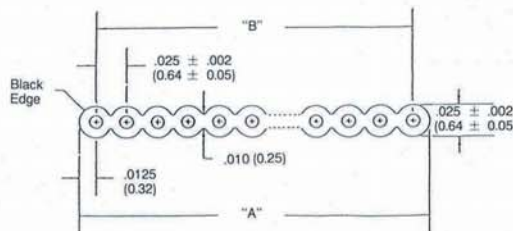

## characteristics physical

**Conductors:** 30 AWG, solid bare copper  
**Shielding:** aluminum poly  
**Insulation:** .0075" (0,19mm) wall PVC  
**Zip thickness:** .025±.002" (0,64±0,05mm) ref.  
**Jacket:** black PVC, 30 mil avg.  
**Pitch:** .025±.002" (0,64±0,05mm) centers  
**Color:** gray (one edge black)

## electrical

**Voltage:** 150 V  
**Current rating:** 0.8 amp nominal @ 10°C above ambient  
**Temperature rating:** -20°C to +105°C (-4°F to 221°F)  
**Impedance:** 55 ohms nominal\*  
**Capacitance:** 30.0 pf/ft. (98,4 pf/m) nominal @ 1.0 MHz\*  
**Inductance:** .12 µh/ft. (.39 µh/m) nominal @ 1.0 MHz\*  
**Propagation delay:** 1.55 ns/ft. (5,09 ns/m) nominal  
**Insulation resistance:** 10<sup>10</sup> ohms - 10 ft. (3 m) min.  
**Unbalanced crosstalk:** 10' sample, 5 ns rise time with 2 lines driven, near end = .8% nominal, far end = 1.8% nominal  
**\*Mode:** ground-signal-ground, shield grounded

**UL: inner: #2678**  
**jacket: #2912**

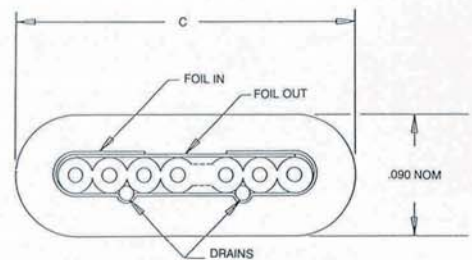

## order information

PART #	# COND	WIDTH A		SPAN B		WIDTH C	
		INCHES	(mm)	INCHES	(mm)	INCHES	(mm)
151-3033-010	10	.250	(6,35)	.225±.005	(5,72±0,13)	.315	(8,00)
151-3033-016	16	.400	(10,16)	.375±.005	(9,53±0,13)	.465	(11,81)
151-3033-020	20	.500	(12,70)	.475±.005	(12,07±0,13)	.565	(14,35)
151-3033-026	26	.650	(16,51)	.625±.005	(15,88±0,13)	.715	(18,16)
151-3033-034	34	.850	(21,59)	.825±.005	(20,96±0,13)	.915	(23,24)
151-3033-040	40	1.000	(25,40)	.975±.006	(24,77±0,15)	1.065	(27,05)
151-3033-050	50	1.250	(31,75)	1.225±.006	(31,12±0,15)	1.315	(33,40)
151-3033-060	60	1.500	(38,10)	1.475±.006	(37,47±0,15)	1.565	(39,75)
151-3033-064	64	1.600	(40,64)	1.575±.006	(40,01±0,15)	1.765	(44,83)
151-3033-068	68	1.700	(43,18)	1.675±.006	(42,51±0,15)	1.865	(47,37)
151-3033-080	80	2.000	(50,80)	1.975±.006	(50,17±0,15)	2.065	(52,45)
151-3033-100	100	2.500	(63,50)	2.475±.007	(62,87±0,18)	2.565	(65,15)



# Spectra-Strip® .025" center Round'N'Flat™ cable 159-3003-XXX series



## characteristics physical

**Conductors:** 30 AWG  
solid bare copper  
**Insulation:** .0075" (0,19mm) wall PVC  
**Zip cable:** gray  
pitch: .025"±.002" (0,64±0,05mm)  
thickness: .025"±.002" (0,64±0,05mm)  
**Shielding:** aluminum/polyester tape,  
tinned copper braid  
w/ min. 85% coverage  
**Jacket:** black PVC .030" wall, paper  
liner between jacket & core  
**Temperature rating:** -20°C to 105°C  
(-4°F to +221°F)

## electrical

**Voltage:** 150 V  
**Impedance:** 65 ohms nominal  
**Capacitance:** 27 pf/ft. (88,6 pf/m)  
nominal @ 1.0 MHz  
**Inductance:** .12 µh/ft. (.39 µh/m)  
nominal @ 1.0 MHz  
**Propagation delay:** 1.6 ns/ft.  
(5,25 ns/m) nominal  
**Insulation resistance:** 10<sup>10</sup> ohms - 10 ft.  
(3 m) min.  
**Unbalanced crosstalk:** 10' sample,  
5 ns rise time with 2 lines driven,  
near end = 2.4% nominal  
far end = 1.0% nominal  
**Mode:** ground-signal-ground,  
shield grounded  
**UL:** inner: 2678, composite: 20470

## description

Spectra-Strip® .025" Round'N'Flat™ Cable combines mass-terminated interconnect miniaturization with the easier routing features of round cable. A repetitive sequence of slitted sections provides a choice of MIDC or hand termination. Shielding options are available to meet application requirements. The inner cable is extruded Spectra-Zip® with alternating sections that are flat. The alternating flat and slit sections also offer an advantage over standard round cable for hand termination, as conductor positions are held in sequence for easy identification.

## benefits

- High-density .025" center-to-center spacing
- Helps meet FCC requirements for EMI/RFI suppression
- Round cable / mass-terminable
- Flat sections keep conductors aligned for conductor positioning if hand-terminating
- Edge mark on #1 conductor for easy identification
- Custom capabilities available:
- UL recognized AWM 

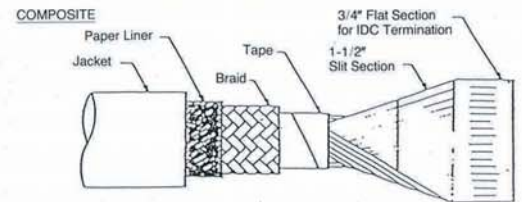
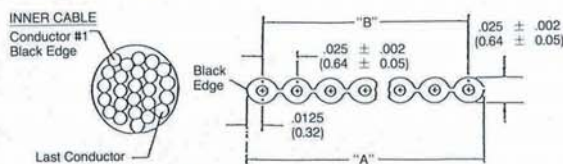

## order information

W/FOIL/BRAID SHIELD & JACKET PART #	W/FOIL SHIELD & JACKET, NO BRAID PART #	W/CLEAR POLY & JACKET, NO SHIELD PART #	# COND	WIDTH A ZIP PROFILE		SPAN B ZIP PROFILE		*REF DIA -0XX
				INCHES	(mm)	INCHES	(mm)	
159-3003-010	159-3003-110	159-3003-210	10	.250	(6,35)	.225±.005	(5,72±0,13)	.270
159-3003-016	159-3003-116	159-3003-216	16	.400	(10,16)	.375±.005	(9,53±0,13)	.275
159-3003-020	159-3003-120	159-3003-220	20	.500	(12,70)	.475±.005	(12,07±0,13)	.280
159-3003-026	159-3003-126	159-3003-226	26	.650	(16,51)	.625±.005	(15,88±0,13)	.285
159-3003-034	159-3003-134	159-3003-234	34	.850	(21,59)	.825±.006	(20,96±0,15)	.295
159-3003-040	159-3003-140	159-3003-240	40	1.000	(25,40)	.975±.006	(24,77±0,15)	.305
159-3003-050	159-3003-150	159-3003-250	50	1.250	(31,75)	1.225±.006	(31,12±0,15)	.320
159-3003-060	159-3003-160	159-3003-260	60	1.500	(38,10)	1.475±.006	(37,47±0,15)	.340
159-3003-064	159-3003-164	159-3003-264	64	1.600	(40,64)	1.575±.006	(40,01±0,15)	.350
159-3003-068	159-3003-168	159-3003-268	68	1.700	(43,18)	1.675±.007	(42,51±0,18)	.360
159-3003-080	159-3003-180	159-3003-280	80	2.000	(50,80)	1.975±.007	(50,17±0,18)	.380
159-3099-994	TBD	TBD	100	2.500	(63,50)	2.475±.007	(62,87±0,18)	.415



# Amphenol Spectra-Strip Slit Cable Capabilities

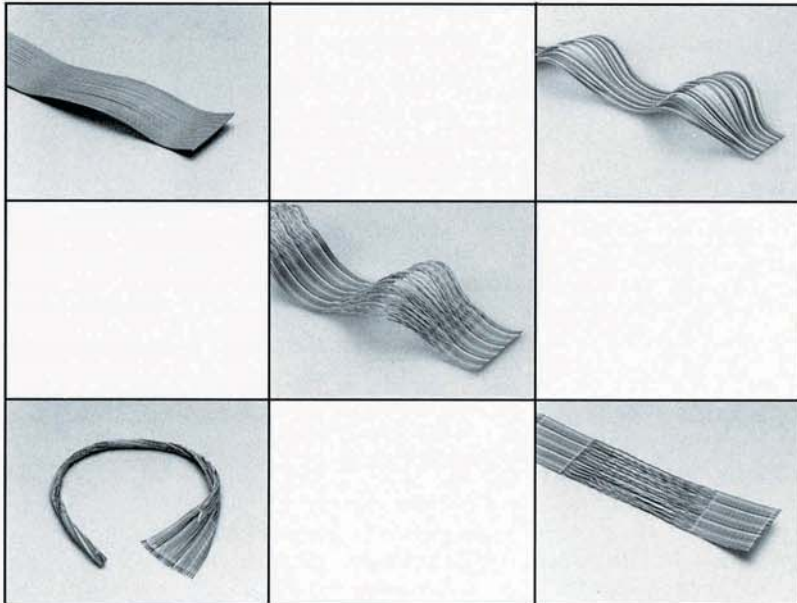

## Benefits:

- Cable can be routed away from components and board for improved air flow.
- Cable routing is easier through almost any space.
- Combines the advantages of flat cable mass IDC termination with the flexibility and ease of routing provided by discrete wire.
- Can accommodate multiple configurations of routing within one cable assembly, through programmable custom slit & unslit sections, or loose twisted pair sections.

## Introduction

Slit cable options fall into two categories: FIXED for extruded (Zip) cable, and PROGRAMMABLE for Zip or Laminated (Color Coded and Twist'N'Flat cable).

The programmable option provides for up to five different unslit/slit length combinations on a repetitive cycle

With the exception of Twist'N'Flat cable, slitting is done on .050" centers such that every conductor of a .050" pitch cable is separated and every other conductor of a .025" pitch cable is separated. Twist'N'Flat cable employs .100" center slitters such that each pair is separated.

AWG's from 26 solid to 32-7/40 are included, for all cable, within pitch and tooling limitations.

Slit dimensions have a tolerance of +/- 0.125" in lengths of 6" or less: +/- 0.250" in lengths greater than 6", and +/- 0.250 in programmed (multiple) lengths.

## Instructions:

Please select the type of slit cable desired. Copy the order form and fill in the Ordering Information and the Customer Information. Fax the form(s) to the fax number shown. A ten digit part number will be promptly assigned to your custom slit cable. If you have any question, please do not hesitate to call for assistance.

## Contents:

Spectra-Zip® Planar Cable 491 Series .....	41
3C® Color Coded Planar Cable 135 Series .....	42
Twist 'N' Flat® Planar Cable 132 Series .....	43
Loose Pair Round Twist 'N' Flat® Cable 432-2802, 433-2802 Series .....	44
Loose Pair Flat Twist 'N' Flat® Cable 432-2806, 433-2806 Series .....	44

# Amphenol

## SPECTRA-STRIP

720 Sherman Ave., Hamden CT 06514  
 Fax: (203) 281-5872  
 Phone: (203) 281-3200  
 (800) 846-6400





**Slit 3C Color Coded Cable**

[Back To Index](#)

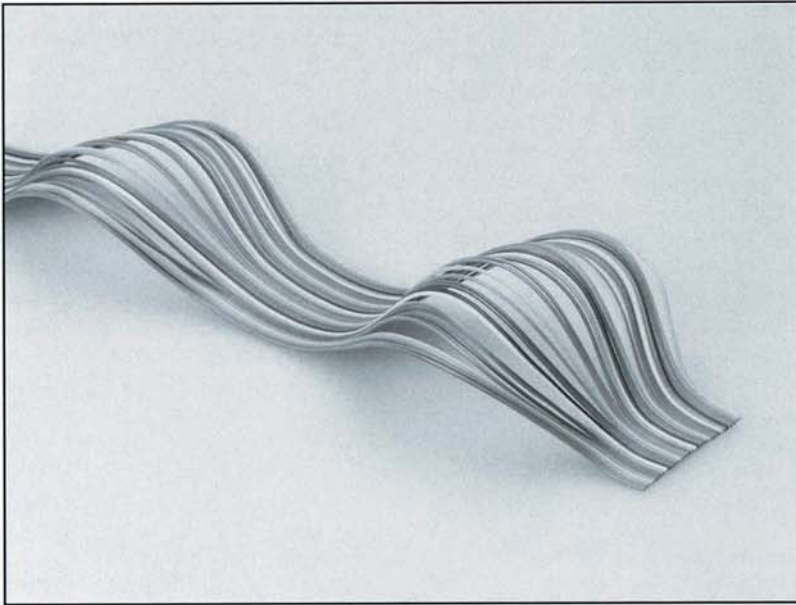

**Characteristics**

- .050" (+/- .005") Pitch
- Conductors: 28 AWG, 7/36 stranded tinned copper
- Color: brown, red, orange, yellow, green, blue, violet, gray, white, black (repeat)
- Cable Thickness: .042" +/- .003
- Insulation: PVC, flame retardant VW-1
- Laminate: clear PVC, self-extinguishing
- Voltage Rating: 300V
- Current Rating: 1 amp nominal @ 10°C (221°F) available
- UL Style: #2697, CSA available, 105°C UL style available
- # of Programmable Lengths Available: up to five different combinations of slit & unslit within one cable
- Length Tolerances: Slit dimensions have a tolerance of +/- 0.125" in programmed (multiple) lengths
- PROGRAMMABLE: 2500' minimum order quantity (you define unslit, slit dimensions)

**Ordering Information:**

Overall put-up length: \_\_\_\_\_ Measure in: feet  meters

Slit: Every conductor       AWG: \_\_\_\_\_      # of conductors: \_\_\_\_\_  
 Every two conductors       Strand: \_\_\_\_\_      (72 maximum)  
 Spacing: \_\_\_\_\_

Slit length measure in: inches  mm

Indicate each unslit and slit length in spaces below.  
 Write in "repeat", if appropriate.

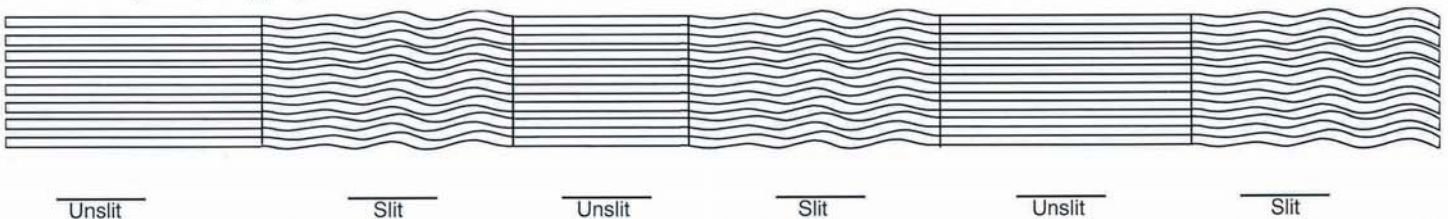

Factory Part Number (will be assigned)

Date \_\_\_\_\_  
 This request for pricing is made by:  
 Name \_\_\_\_\_  
 Title \_\_\_\_\_  
 Company \_\_\_\_\_  
 Address \_\_\_\_\_  
 City \_\_\_\_\_ State \_\_\_\_\_ Zip \_\_\_\_\_  
 Phone No. (\_\_\_\_) \_\_\_\_\_  
 Fax No. (\_\_\_\_) \_\_\_\_\_  
 Comments: \_\_\_\_\_

Copy & Fax to: Cable Marketing Manager

**Amphenol**  
**SPECTRA-STRIP**

Fax: (203) 281-5872  
 Phone: (203) 281-3200  
 (800) 846-6400



**Slit Flat Twist'N'Flat Planar Cable**

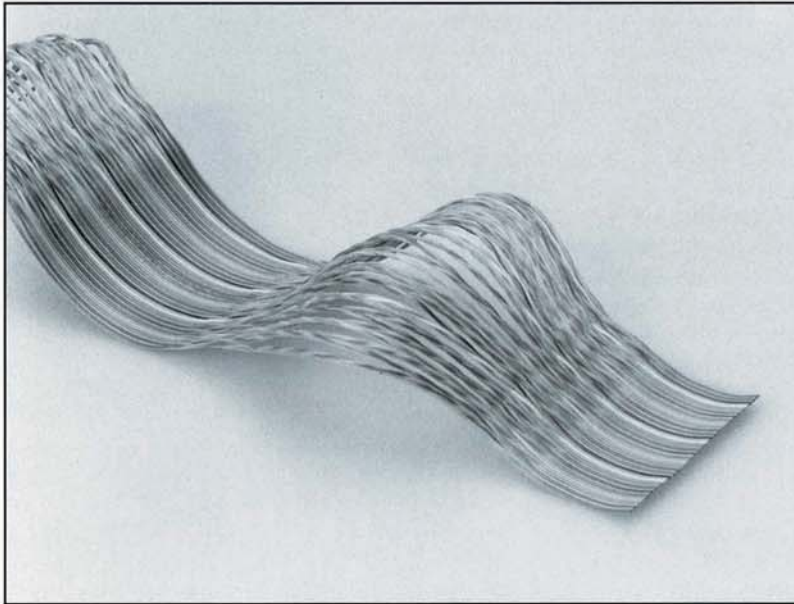

**Characteristics**

- .050" (+/- .005") Pitch
- Conductors: 28 AWG, 7/36 strand tinned copper
- Color: brown, red, orange, yellow, green, blue, violet, gray, white, black (repeat) - tan common
- Cable Thickness: .042" +/- .003"
- Insulation: PVC, flame retardant VW-1
- Laminate: clear PVC, self-extinguishing
- Voltage Rating: 300V
- Current Rating: 1 amp nominal @ 10°C
- Temperature Rating: -20°C to 80°C (14°F to 176°F)
- UL Style: #2697, CSA available, 105°C UL style available
- # of Programmable Lengths Available: up to five different combinations of flat and five different combinations of twisted pair lengths available (total of 10 combined) within one cable
- Length Tolerances: slit dimensions have a tolerance of +/- 0.125" in lengths of 6" or less; +/- 0.250 in lengths greater than 6", and +/- 0.250 in programmed (multiple) lengths.
- Single Program:
  - Minimum Twisted Pair Length: 5"
  - Minimum Flat Length: 1"
- Multiple Program:
  - Minimum Twisted Pair Length: 6"
  - Minimum Flat Length: 1.5"
- PROGRAMMABLE: 1000' MINIMUM ORDER QUANTITY

**Ordering Information:**

Overall put-up length: \_\_\_\_\_ Measure in: feet  meters

Slit: Between each pair      AWG: \_\_\_\_\_ # of conductors: \_\_\_\_\_  
 Strand: \_\_\_\_\_ (68 Maximum)  
 Spacing: \_\_\_\_\_ (34 twisted pair)

Slit length measure in: inches  mm

Indicate each unslit flat and slit between pairs length in spaces below.  
 Write in "repeat", if appropriate.

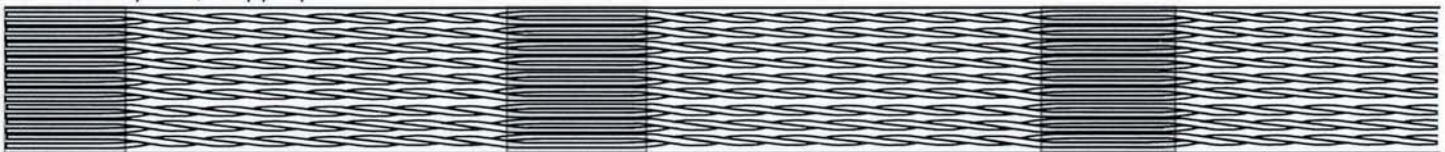

Flat      Slit Between Pairs      Flat      Slit Between Pairs      Flat      Slit Between Pairs

Factory Part Number (will be assigned)

**Customer Information:**

Copy & Fax to: Cable Marketing Manager



Fax: (203) 281-5872  
 Phone: (203) 281-3200  
 (800) 846-6400

Date \_\_\_\_\_  
 This request for pricing is made by:  
 Name \_\_\_\_\_  
 Title \_\_\_\_\_  
 Company \_\_\_\_\_  
 Address \_\_\_\_\_  
 City \_\_\_\_\_ State \_\_\_\_\_ Zip \_\_\_\_\_  
 Phone No. (\_\_\_\_) \_\_\_\_\_  
 Fax No. (\_\_\_\_) \_\_\_\_\_  
 Comments: \_\_\_\_\_

# Flat Loose pair twist 'n' flat® Round Loose pair twist 'n' flat® 432-2802/433-2802 (round) 432-2806/433-2806 (flat)

## 432/433 series

### 432-2802/433-2802 Series

2.5" flat/1.75" flat  
(provided in round form)

### 432-2806/433-2806 Series

2.5" flat/1.75" flat  
(provided in flat form)

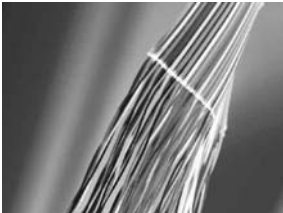

### Characteristics

- .050" (± .005") Pitch
- Conductors: 28 AWG, 7/36 Strand Tinned Copper
- Color Code: Brown, Red, Orange, Yellow, Green, Blue, Violet, Gray, White, Black and Repeat with Tan Common
- Cable Thickness: .042" ± .003"
- Insulation: PVC, Flame Retardant VW -1
- Flat Laminate: Clear PVC, Self-Extinguishing
- Voltage Rating: 300V
- Current Rating: 1 amp Nominal @ 10° C
- Temperature Rating: -20° C to +105° C (-4° F to 221° F)
- UL Style: AWM #20130, CSA Available
- Number of Programmable Lengths Available: Up to Ten  
Different Twisted Pair Lengths Available
- Cable is Provided in Flat or Round Bundled Form. (You Specify)

### 432-2802/432-2806 Series

- Flat Length: 2.5" ± .125"
- Minimum Twisted Pair Length: 5.5" ± .500"

### 433-2802/433-2806 Series

- Flat Length: 1.75" ± .125"
- Minimum Twisted Pair Length: 3.5" ± .500"

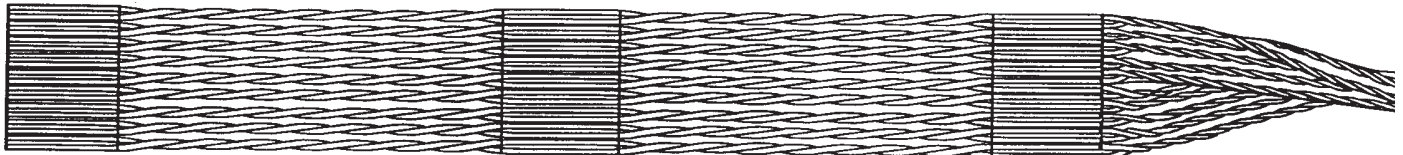

flat

loose pairs

flat

loose pairs

flat

loose pairs

### Ordering Information

Overall put-up length: \_\_\_\_\_ Measure in:  feet  meters

Loose twisted pairs provided: \_\_\_\_\_ AWG: \_\_\_\_\_ # of conductors: \_\_\_\_\_

in round form

(68 maximum, 34 Twisted Pair)

in flat form

Length measured in:  inches  mm

Indicate each unslit flat and loose pair length in spaces above.

Write in "repeat", if appropriate.



# Spectra-Strip® Halogen-Free Flame-Retardant Cables

[Back To Index](#)



## for today's demanding requirements...

Amphenol Spectra-Strip now offers a broad line of halogen-free, flame retardant cables. Halogen-free cable is ideally suited for use in congested areas where ventilation is poor, such as buses, subways, elevators, data processing rooms, ships, aircraft, nuclear facilities, and other enclosed environments...anywhere PVC is forbidden, or where personnel and equipment could be injured by toxic and corrosive gases. (When PVC heats up, or catches fire, toxic and corrosive halogens escape.) Beyond its environmental benefits, halogen-free cable prevents memory degradation due to outgassing PVC corrosion. Protection of components from corrosion is critical in applications requiring high speed computing. Non-PVC cables are a growing trend for government contractors. Spectra-Strip manufactures its halogen-free cables in many of its popular configurations.

## benefits

- Wide range of operating temperatures on most configurations: -25°C to +90°C (-65°C to +150°C available)
- Highly flame retardant insulation: limiting oxygen index on most configurations of 39%
- Reduced generation of toxic and corrosive gases during combustion
- Low smoke generation upon combustion
- Popular configurations for a wide variety of applications
- Mass terminable
- Custom capabilities available

## general characteristics

*Limiting oxygen index:* ASTM-D-2863 39%

*Toxicity index:* NES 713, 1.4

*Optical smoke index:* NES 711, 5.3

*Acid gas generation:* MIL-C 24643, 0.47%

*Flammability:* VW-1

*UL:* approved or pending for each configuration

### **.025" Loose Pair Twist 'N' Flat®**

**425-3016 series**

**Page 33**

### **Spectra-Zip®**

**193-2829 series**

**Page 46**

### **Twist 'N' Flat®**

**132-2829 series**

**Page 47**

### **Loose Pair Twist 'N' Flat®**

**468-2829 series**

**Page 48**

### **Loose Pair Round Twist 'N' Flat®**

**168-2829 series**

**Page 49**

# Halogen-Free Zip cable

## 193-2829 series



### description

Halogen-free Zip Cable is designed to reduce the generation of toxic and corrosive gases during combustion. Halogen-free Zip cable can be used in more severe operating environments than standard flat ribbon cables. This cable consists of 28 AWG stranded round conductors on .050" centers with an extruded halogen-free FR, polyolefin insulation. This insulation allows the cable to meet UL VW-1 flammability requirements without the use of halogenated flame retardants.

### benefits

- Wide range of operating temperatures: -25°C to +90°C
- Highly flame retardant insulation: limiting oxygen index of 39%
- Reduced generation of toxic and corrosive gases during combustion
- Number one conductor stripe for easy polarity identification
- Low smoke generation upon combustion

### order information

PART #	# COND	WIDTH A " (mm)	SPAN B " (mm)
193-2829-009	9	.450 (11,43)	.400±.007 (10,16±0,18)
193-2829-010	10	.500 (12,70)	.450±.007 (11,43±0,18)
193-2829-014	14	.700 (17,78)	.650±.007 (16,51±0,18)
193-2829-015	15	.750 (19,05)	.700±.007 (17,78±0,18)
193-2829-016	16	.800 (20,32)	.750±.011 (19,05±0,28)
193-2829-020	20	1.000 (25,40)	.950±.011 (24,13±0,28)
193-2829-024	24	1.200 (30,48)	1.150±.011 (29,21±0,28)
193-2829-025	25	1.250 (31,75)	1.200±.011 (30,48±0,28)
193-2829-026	26	1.300 (33,02)	1.250±.011 (31,75±0,28)
193-2829-034	34	1.700 (43,18)	1.650±.011 (41,91±0,28)
193-2829-036	36	1.800 (45,72)	1.750±.015 (44,45±0,38)
193-2829-037	37	1.850 (47,00)	1.800±.015 (45,72±0,38)
193-2829-040	40	2.000 (50,80)	1.950±.015 (49,53±0,38)
193-2829-050	50	2.500 (63,50)	2.450±.015 (62,23±0,38)
193-2829-060	60	3.000 (76,20)	2.950±.015 (74,93±0,38)
193-2829-064	64	3.200 (81,28)	3.150±.015 (80,01±0,38)

Consult factory for 193-2821-0XX -65°C to +150°C version

### characteristics

#### physical

*Conductors:* 28 AWG, 7/36 strand, tinned copper  
*Number of conductors:* see order information chart  
*Insulation:* .010" wall extruded, Halogen-Free, FR, Polyolefin  
*Thickness:* .035", ±.003"  
*Pitch:* .050" centers, ±.003"  
*Color code:* white with edge mark  
*Limiting oxygen index:* ASTM-D-2863 39%  
*Halogen content:* MIL-C-24643, .01%  
*Toxicity index:* NES 713, 1.4  
*Smoke index:* NES 711, 5.3  
*Acid gas generation:* MIL-C-24643, 0.47%  
*Flammability:* VW-1

#### electrical

*Voltage:* 300 V  
*Current rating:* 1 amp nominal @ 10°C above ambient  
*Temperature rating:* -25°C to +90°C (-13°F to 194°F)  
*Impedance:* 100 ohms nominal  
*Capacitance:* 13.0 pf/ft. (42,7 pf/m) nominal @ 1.0 MHz  
*Propagation delay:* 1.45 ns/ft. (4,6 ns/m) nominal  
*Insulation resistance:* 10<sup>10</sup> ohms - 10 ft. (3 m) min.  
*Mode:* ground-signal-ground

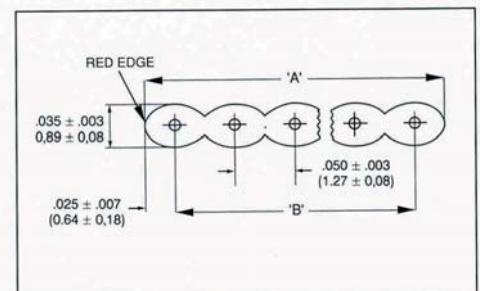



# Halogen-Free Twist 'N' Flat® planar cable

## 132-2829 series

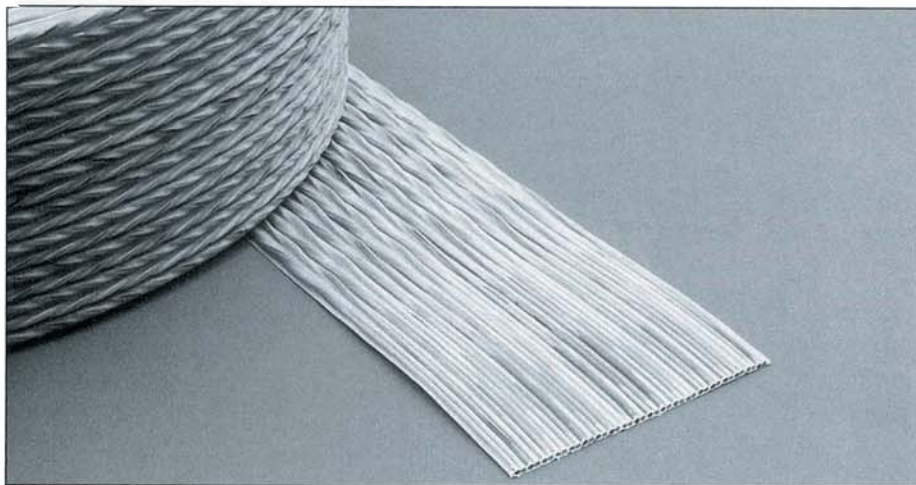

### characteristics

#### physical

**Conductors:** 28 AWG, 7/36 strand, tinned copper  
**Insulation:** .010" wall extruded, Halogen-Free, FR, Polyolefin  
**Thickness:** .042",  $\pm .003$ " (flat section)  
**Laminate:** Halogen-Free, FR Polyolefin  
**Pitch:** flats: .050" centers,  $\pm .005$ ", twisted-pairs: .100" (nominal) centers  
**Color code:** tan common, brown, red, orange, yellow, green, blue, violet, gray, white, black, (repeat)  
**Limiting oxygen index:** ASTM-D-2863 39%  
**Toxicity index:** NES 713, 1.4  
**Smoke index:** NES 711, 5.3  
**Acid gas generation:** MIL-C-24643, 0.47%

#### electrical

**Voltage:** 300 V  
**Current rating:** 1 amp nominal @ 10°C above ambient  
**Temperature rating:** -25°C to +90°C (-13°F to 194°F)  
**Impedance:** 100 ohms nominal  
**Capacitance:** 14.0 pf/ft. (45,92 pf/m) nominal @ 1.0 MHz  
**Propagation delay:** 1.6 ns/ft. (5,3 ns/m) nominal  
**Insulation resistance:** 10<sup>10</sup> ohms - 10 ft. (3 m) min.  
**Unbalanced crosstalk:** 10' sample, 5 ns rise time with 2 lines driven, near end = 3.9% far end = 3.7%  
**Mode:** ground-signal

### description

Halogen-Free Twist 'N' Flat cable combines the benefits of mass-terminable flat cable with the electrical performance of twisted pairs, with the added benefits of halogen-free, highly flame retardant cable. This cable is well suited to equipment such as communications and computing applications, within closed environments, or wherever PVC is forbidden. This mass-terminable cable can attain up to 95% labor-savings over discrete strip & crimp termination methods. Twist 'N' Flat consists of 18" (45,7 cm) sections of stranded round conductors, twisted into pairs, with 2" (5,1 cm) flat sections of parallel conductors for termination.

### benefits

- Twist is reversed in adjacent pairs for reduced cross-talk
- Wide range of operating temperatures: -25°C to +90°C
- Highly flame retardant: limiting oxygen index of 39%
- Reduced generation of toxic and corrosive gases during combustion
- Low smoke generation upon combustion
- Put-up in convenient 100' rolls
- Custom capabilities available:
- Custom twist sections (6" to several feet), up to five different twist lengths in same cable, and repeat
- Loose laminate sections for access to individual conductors

### order information

PART #	# PAIRS	WIDTH A " (mm)	SPAN B " (mm)
132-2829-010	5	.526 (13,36)	.450 $\pm$ .015 (11,43 $\pm$ 0,38)
132-2829-014	7	.726 (18,44)	.650 $\pm$ .015 (16,51 $\pm$ 0,38)
132-2829-016	8	.826 (20,98)	.750 $\pm$ .015 (19,05 $\pm$ 0,38)
132-2829-020	10	1.026 (26,06)	.950 $\pm$ .015 (24,13 $\pm$ 0,38)
132-2829-026	13	1.326 (33,68)	1.250 $\pm$ .015 (31,75 $\pm$ 0,38)
132-2829-034	17	1.726 (43,84)	1.650 $\pm$ .015 (41,91 $\pm$ 0,38)
132-2829-036	18	1.826 (46,38)	1.750 $\pm$ .015 (44,45 $\pm$ 0,38)
132-2829-040	20	2.026 (51,46)	1.950 $\pm$ .020 (49,53 $\pm$ 0,51)
132-2829-050	25	2.526 (64,16)	2.450 $\pm$ .020 (62,23 $\pm$ 0,51)
132-2829-060	30	3.026 (76,86)	2.950 $\pm$ .020 (74,93 $\pm$ 0,51)
132-2829-064	32	3.226 (81,94)	3.125 $\pm$ .025 (80,01 $\pm$ 0,64)

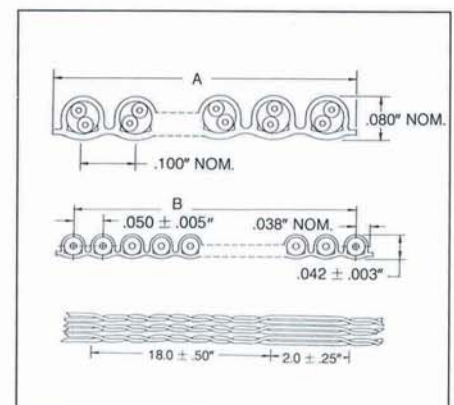

Consult factory for 132-2821-0XX -65°C to +150°C version

720 Sherman Avenue Hamden CT, 06514 in CT, call 1.203.281.3200 Fax 1.203.281.5872  
 1.800.846.6400 sales@spectra-strip.com http://www.spectra-strip.com

# Halogen-Free Loose Pair Twist 'N' Flat<sup>®</sup> cable 468-2829 series

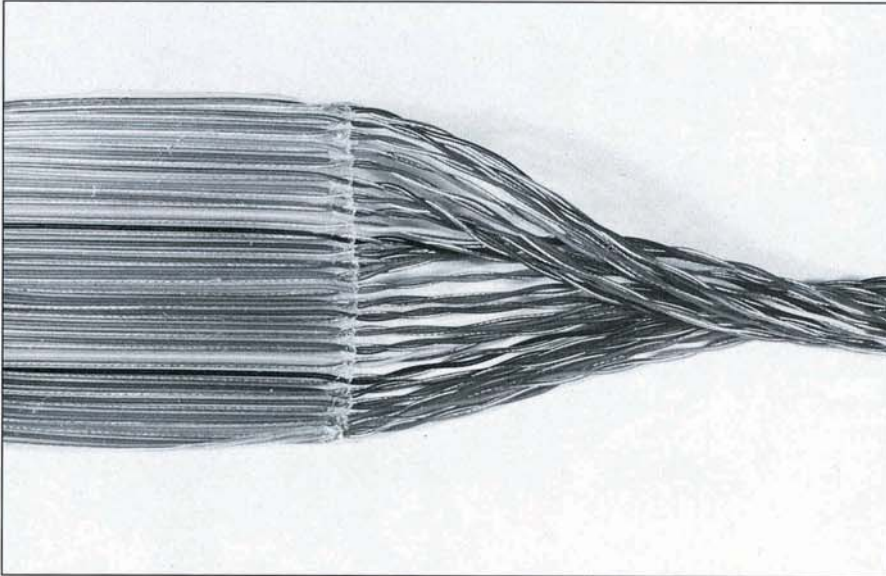

## description

Halogen-free, Loose Pair Twist 'N' Flat Cable combines the electrical characteristics of loose conductor, twisted pair cable with the time and cost savings of mass-terminated cable...with the added bonus of halogen-free materials ideal for use in closed environments. It is designed to reduce the generation of toxic and corrosive gases during combustion. It consists of insulated stranded round conductors, twisted into loose pairs. Every 17.5", the conductors are laminated into parallel .050" center 2.5" sections for mass-termination.

## benefits

- Highly flame retardant
- Reduced generation of smoke and toxic and corrosive gases during combustion
- Custom capabilities: laminated sections can be fabricated at custom intervals, from 6" minimum twist length, up to ten different twist lengths in same cable and repeat, to maximum determined by put-up
- Bulk put-up on reel in round form

## order information

PART #	# PAIRS	WIDTH A " (mm)	SPAN B " (mm)
468-2829-010	5	.526 (13,36)	.450 (11,43)
468-2829-014	7	.726 (18,44)	.650 (16,51)
468-2829-016	8	.826 (20,98)	.750 (19,05)
468-2829-020	10	1.026 (26,06)	.950 (24,13)
468-2829-026	13	1.326 (33,68)	1.250 (31,75)
468-2829-034	17	1.726 (43,84)	1.650 (41,91)
468-2829-040	20	2.026 (51,46)	1.950 (49,53)
468-2829-050	25	2.526 (64,16)	2.450 (62,23)
468-2829-060	30	3.026 (76,86)	2.950 (74,93)
468-2829-064	32	3.226 (81,94)	3.150 (80,01)

Consult factory for 468-2832-0XX -65°C to +150°C version

## characteristics

### physical

*Conductors:* 28 AWG, 7/36 strand, tinned copper  
*Insulation:* .010" wall extruded, Halogen-Free, FR, Polyolefin  
*Color code:* tan common, brown, red, orange, yellow, green, blue, violet, gray, white, black, (repeat)  
*Flat pitch:* .050" centers, ±.005"  
*Flat laminate:* halogen-free polyolefin, white, .005"  
*Limiting oxygen index:* ASTM-D-2863  
 primary: 39%, laminate: 28%

### electrical

*Voltage:* 300 V  
*Current rating:* 1.3 amp nominal @ 10°C above ambient  
*Temperature rating:*  
 -25°C to +90°C  
 (-13°F to 194°F)  
*Impedance:* 120 ohms nominal  
*Capacitance:* 11.3 pf/ft. (37,0 pf/m) nominal @ 1.0 MHz  
*Propagation delay:* 1.6 ns/ft. (5,3 ns/m) nominal  
*Insulation resistance:* 10<sup>10</sup> ohms - 10 ft. (3 m) min.  
*Unbalanced crosstalk:* 10' sample, 5 ns rise time with 2 lines driven, near end = 4.0% far end = 1.6% nominal  
*Mode:* ground-signal  
*UL:* pending

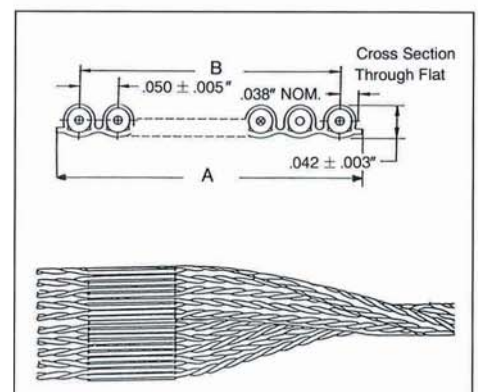



# Halogen-Free Loose Pair Round Twist 'N' Flat<sup>®</sup> cable

## 168-2829 series

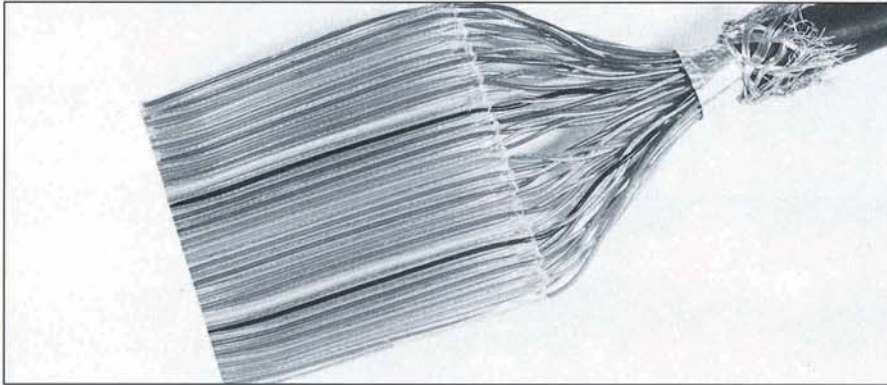

### description

Halogen-free, Loose Pair Round Twist 'N' Flat Cable combines the electrical characteristics of loose conductor, twisted pair cable with the time and cost savings of mass-terminated cable...with the added bonus of halogen-free materials ideal for use in closed environments. It is designed to reduce the generation of toxic and corrosive gases during combustion. It consists of an inner cable of insulated stranded round conductors, twisted into loose pairs. Every 20", the conductors are laminated into parallel .050" center 2.5" sections for mass-termination. It is covered with a foil shield, a tinned-copper braid, and a halogen-free jacket.

### benefits

- Highly flame retardant
- Reduced generation of smoke or toxic/corrosive gases during combustion
- Help meet FCC requirements for EMI/RFI suppression
- Custom capabilities: laminated sections can be fabricated at custom intervals, from 6" minimum twist length, to maximum determined by put-up, up to ten different twist lengths in same cable and repeat

### order information

PART #	# PAIRS	WIDTH A " (mm)	SPAN B " (mm)	REF. DIA. " X=0 (X=1,2)
168-2829-X10	5	.526 (13,36)	.450 (11,43)	.250 (.220)
168-2829-X14	7	.726 (18,44)	.650 (16,51)	.260 (.230)
168-2829-X16	8	.826 (20,98)	.750 (19,05)	.280 (.250)
168-2829-X20	10	1.026 (26,06)	.950 (24,13)	.290 (.260)
168-2829-X26	13	1.326 (33,68)	1.250 (31,75)	.310 (.280)
168-2829-X34	17	1.726 (43,84)	1.650 (41,91)	.360 (.330)
168-2829-X40	20	2.026 (51,46)	1.950 (49,53)	.390 (.360)
168-2829-X50	25	2.526 (64,16)	2.450 (62,23)	.430 (.400)
168-2829-X60	30	3.026 (76,86)	2.950 (74,93)	.470 (.440)
168-2829-X64	32	3.226 (81,94)	3.150 (80,01)	.480 (.450)

Consult factory for  
168-2832-XXX  
-65°C to +150°C version

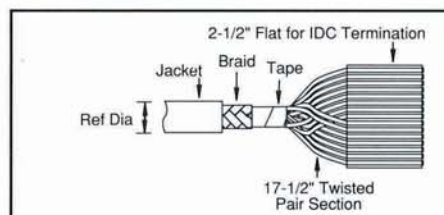

### characteristics

#### physical

**Conductors:** 28 AWG, 7/36 strand, tinned copper  
**Insulation:** .010" wall extruded, Halogen-Free, FR, Polyolefin  
**Color code:** tan common, brown, red, orange, yellow, green, blue, violet, gray, white, black, (repeat)  
**Flat pitch:** .050" centers,  $\pm .005$ "  
**Flat laminate:** halogen-free polyolefin, white, .005"  
**Foil Shield:** Aluminum/polyester  
**Braid:** tinned-copper, with minimum 90% coverage  
**Jacket:** Halogen-free polyolefin, .030" wall  
**Overall cable length:** 8-24":  $\pm .500$ ", 24"-25":  $\pm 1.0$ ", 25'+:  $\pm 2.0$ "  
**Limiting oxygen index:** ASTM-D-2863 39%

#### electrical

##### (fully shielded version)

**Voltage:** 300 V  
**Current rating:** 1 amp nominal @ 10°C above ambient  
**Temperature rating:** -25°C to +90°C (-13°F to 194°F)  
**Jacket:** -20°C to +90°C  
**Impedance:** 75 ohms nominal  
**Capacitance:** 24.0 pf/ft. (78,7 pf/m) nominal @ 1.0 MHz  
**Propagation delay:** 1.6 ns/ft. (5,3 ns/m) nominal  
**Insulation resistance:** 10<sup>10</sup> ohms - 10 ft. (3 m) min.  
**Unbalanced crosstalk:** 10' sample, 5 ns rise time with 2 lines driven, near end = 2.3% far end = 1.3% nominal  
**Mode:** ground-signal, with shield grounded  
**UL:** pending

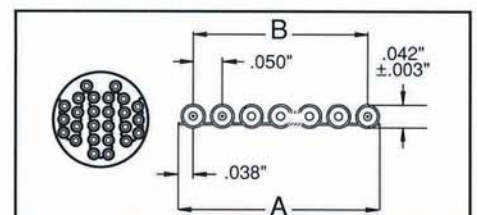

# Spectra-Strip® flat cable cross reference table

## flat cable cross reference table

Description	AWG	Strand	New Spectra-Strip Part Number	Old Spectra-Strip Part Number
Zip, gray	26	1	843-191-2602-0XX	131-2600-0XX
Zip, gray	28	7	● 843-191-2801-1XX	455-240-XX
Zip, gray	28	1	843-191-2802-0XX	455-301-XX
Zip, gray	30	1	843-191-3001-0XX	455-241-XX
Zip, jacketed	28	7	● 843-151-2811-0XX	151-2810-0XX
Zip, jacketed & aluminum mylar	28	7	● 843-151-2831-0XX	151-2830-0XX
Zip, jacketed & copper mesh	28	7	843-151-2821-0XX	
Ground Plane, drain wire	28	7	● 843-133-2801-0XX ● 843-133-2803-0XX	455-276-XX
Ground Plane, without drain wire	28	7	● 843-133-2802-0XX ● 843-133-2804-0XX	455-277-XX
Ground Plane, 3C drain wire	28	7	843-134-2801-0XX	455-318-XX
Ground Plane, jacketed	28	7	843-153-2811-0XX	153-2810-0XX
Ground Plane, jacketed & shielded	28	7	843-153-2831-0XX	153-2830-0XX
Twist 'N' Flat	28	7	● 843-132-2801-0XX	455-248-XX
Twist 'N' Flat, jacketed	28	7	843-152-2811-0XX	152-2810-0XX
Twist 'N' Flat, jacketed & shielded	28	7	843-152-2831-0XX	152-2830-0XX
3C	28	7	● 843-135-2801-0XX	455-044-XX
3C, twisted pairs	26	7	● 843-138-2601-0XX	455-278-XX
Bonded	22	7	● 843-111-2213-0XX	SS-XX22-7B
Bonded	24	7	● 843-111-2413-0XX	SS-XX24-7B
Bonded	26	7	● 843-111-2609-0XX	SS-XX26-7B
Bonded	22	19	● 843-111-2214-0XX	SS-XX22-19B
Bonded	24	19	● 843-111-2414-0XX	SS-XX24-19B



# copper conductor data

## round conductor

AWG <sup>(1)</sup>	Stranding	Type Stranding <sup>(5)</sup>	Diameter		Area		Weight		D.C. Resistance @20°C <sup>(2)</sup>			
			In.	mm	circ. mils	sq. mm	lbs./M'	kg/km	Tin Coating <sup>(4)</sup>		Bare <sup>(3)</sup> or Silver Coating	
									ohms/M'	ohms/km	ohms/M'	ohms/km
32	Solid	—	.0080	.203	64	.0324	.194	.289			162.00	532.00
30	Solid	—	.0100	.254	100	.0507	.303	.451	113.00	371.00	104.00	340.00
30	7/38	Bunched	.0120	.305	112	.0570	.350	.520	92.60	304.00	92.60	303.00
30	26/44	Rope Lay	.0150	.381	104	.0527	.375	.558	—	—	100.00	328.10
28	Solid	—	.0126	.320	159	.0806	.481	.716	70.80	232.00	65.30	214.00
28	7/36	Concentric	.0150	.381	175	.0890	.550	.820	67.50	221.00	59.30	194.00
28	26/42	Bunched	.0157	.399	179	.0906	.567	.844	66.67	218.74	—	—
26	Solid	—	.0159	.404	253	.1280	.765	1.140	44.50	146.00	41.00	135.00
26	7/34	Concentric	.0190	.483	278	.1410	.870	1.290	42.50	139.00	37.30	122.00
26	19/38	Concentric	.0210	.533	304	.1540	.970	1.440	38.90	128.00	34.10	112.00
26	64/44	Rope Lay	.0200	.508	256	.1297	.884	1.315	—	—	40.00	131.24
24	Solid	—	.0201	.511	404	.2050	1.220	1.820	27.20	89.20	25.70	84.20
24	7/32	Concentric	.0240	.610	448	.2270	1.380	2.050	25.70	84.20	23.10	75.90
24	19/36	Concentric	.0250	.635	475	.2410	1.480	2.200	24.90	81.70	21.80	71.60
24	105/44	Rope Lay	.0290	.7366	420	.2128	1.60	2.380	—	—	24.75	81.21
22	Solid	—	.0253	.643	640	.3240	1.940	2.890	16.70	54.80	16.20	53.20
22	7/30	Concentric	.0310	.787	700	.3550	2.190	3.260	16.60	54.40	14.80	48.60
22	19/34	Bunched	.0320	.813	754	.3820	2.350	3.500	15.50	50.80	13.80	45.10
22	105/42	Rope Lay	.0300	.762	651	.3299	2.49	3.705	16.67	54.69	—	—
20	Solid	—	.0320	.813	1,020	.5190	3.100	4.610	10.50	34.40	10.10	33.20
20	7/28	Concentric	.0380	.965	1,111	.5620	3.490	5.190	10.30	33.80	9.33	30.60
20	19/32	Concentric	.0400	1.020	1,216	.6160	3.840	5.710	9.48	31.10	8.53	28.00
20	105/40	Rope Lay	.0400	1.016	1,008	.5108	3.24	4,821	10.53	34.55	—	—
18	Solid	—	.0403	1.020	1,620	.8230	4.920	7.320	6.77	22.20	6.39	21.00
18	7/26	Concentric	.0480	1.220	1,770	.8970	5.550	8.260	6.45	21.20	5.55	19.20
18	19/30	Concentric	.0500	1.270	1,900	.9630	5.950	8.850	6.10	20.00	5.46	17.90
18	105/38	Rope Lay	.0560	1.422	1,596	.8087	5.30	7.886	6.82	22.38	—	—



# copper conductor data

## Round Conductor (cont.)

AWG <sup>(1)</sup>	Stranding	Type Stranding <sup>(5)</sup>	Diameter		Area		Weight		D.C. Resistance @ 20°C <sup>(2)</sup>			
			in.	mm	circ. mils	sq. mm	lbs./M'	kg/km	Tin Coating <sup>(4)</sup>		Bare <sup>(3)</sup> or Silver Coating	
									ohms/M'	ohms/km	ohms/M'	ohms/km
16	Solid	—	.0508	1.290	2,580	1.31	7.81	11.60	4.47	14.70	4.02	13.20
16	19/29	Bunched	.0570	1.450	2,426	1.23	7.52	11.20	4.82	15.80	4.27	14.00
16	105/36	Rope Lay	.0620	1.574	2,625	1.33	8.20	12.20	4.37	14.34	—	—
14	Solid	—	.0641	1.630	4,100	2.08	12.40	18.50	2.68	8.79	2.52	8.28
14	19/27	Concentric	.0710	1.800	3,831	1.94	12.10	18.01	3.05	10.00	2.71	8.88
14	41/30	Bunched	.0770	1.960	4,100	2.08	12.88	19.17	2.81	9.22	2.53	8.30
12	Solid	—	.0808	2.050	6,530	3.31	19.80	29.50	1.69	5.54	1.59	5.21
12	19/25	Concentric	.0900	2.290	6,088	3.08	19.38	28.84	1.87	6.13	1.70	5.59
12	65/30	Bunched	.0910	2.310	6,500	3.29	20.76	30.89	1.82	5.97	1.60	5.23

(1) For stranded conductors, nearest AWG size is listed.

(2) Typical D.C. resistance values for uninsulated wires. Multiply by 1.04 for typical values after insulation.

(3) Bare annealed copper wire per ASTM B 3.

(4) Tinned annealed copper wire per ASTM B 33.

(5) • Concentric lay stranded conductor, per ASTM B 8.

• Spectra-Strip bunched stranding is unilay or "smooth bunched" for premium lay, per ASTM B 174.

• Spectra-Strip rope lay stranding (for Ultra-Flex cables) consists of bunch stranded groups cabled into single construction, per ASTM B 172. Characteristics subject to minor variations.

# flat conductor

## Flat Conductor Sizes Equivalent to Conventional Round Conductors

Required width of flat conductor for given thickness.

Round Cond. AWG	Solid Wire Dia.	Area In. <sup>2</sup>	Weight lbs/1000 Feet	Feet/Pound	Rdc at 68°F ohm 1000 feet	Conductor Thickness												
						.001	.002	.003	.004	.005	.006	.007	.008	.009	.010			
32	.0080	5.03x10 <sup>-5</sup>	.1913	5160	170.600	.0503	.0252	.0168	.0126	.0101	.00839	.0072						
30	.0100	7.85x10 <sup>-5</sup>	.3042	3300	107.300	.0785	.0392	.0262	.0196	.0157	.01310	.0112	.00972					
28	.0126	.000125	.4837	2080	67.490	.1250	.0626	.0420	.0313	.0250	.02080	.0179	.01560	.0139	.0125			
26	.0159	.000199	.7692	1310	42.440	.1990	.0995	.0625	.0500	.0400	.03320	.0285	.02490	.0222	.0199			
24	.0201	.000317	1.2230	818	26.690	.3170	.1590	.1060	.0793	.0625	.05280	.0453	.04000	.0352	.0317			
22	.0253	.000503	1.9450	516	16.700	.5030	.2520	.1670	.1260	.1000	.08380	.0718	.06380	.0558	.0503			
20	.0320	.000804	3.0920	323	10.560	.8040	.4020	.2680	.2010	.1610	.13400	.1150	.10000	.0893	.0800			
18	.0403	.001280	4.9170	203	6.640	1.2800	.6410	.4270	.3200	.2560	.21400	.1830	.16000	.1420	.1250			
16	.0508	.002030	7.8180	128	4.176	2.0300	1.0200	.6840	.5130	.4100	.34200	.2930	.25600	.2280	.2030			



## copper conductor data

**Current Ratings:** All conductors have been assigned current ratings based on the amount of current that will produce certain rises in conductor temperature under specified conditions. The allowable temperature rise above ambient is generally determined by the temperature capacity of the conductor insulation, the desired total temperature of the application — or, other factors.

**Heat Dissipation:** The heat transfer capability of the conductor insulation will either aid or impede the conduction/convection process by which heat is dissipated. If the designer provides a heat-conducting path, like an adjacent wire or other component normally operating at a significantly lower temperature, the conductor heat will dissipate very efficiently through the insulation. Dissipation to free air through convection is a good method, but in most applications the amount of free air available to each conductor is extremely limited.

**Establishing Ratings:** A size 26 AWG wire operating in free air at 20°C will increase in temperature about 35°C when carrying 3 amps. Adding the ambient 20°C and the current induced rise 35°C brings the operating temperature of the wire to 55°C — not an extremely high operating temperature — which is considered allowable current-versus-temperature for a single standard 26 AWG wire with 80°C PVC insulation.

Reference to the current rating chart will show that for a 28 AWG planar cable, the maximum current for a 10°C temperature rise is 1.0 amp; 2.0 amps for a 35°C rise; and 4.0 amps for a 140°C rise. A 10°C temperature rise is recommended in most electronic applications and therefore the current design for #28 AWG should ordinarily be limited to 1.0 amp.

The intent of these arbitrary ratings however is to indicate tolerable temperatures for maximum conductor efficiency when the rating of insulation materials and device total operating temperature will allow. In addition, voltage drop limitations often preclude the full current capacity use in most applications.

**Derating:** The optimum ratings are those which will produce tolerable temperature rises; in practice, they are usually derated, because in designing a circuit the engineer does not normally take into account other factors influencing wire temperature beyond the actual pas-

sage of current. What the designer knows least about, in advance, is the precise mechanical interrelationship that an individual circuit wire will experience when placed in the final assembly. Because of this, he derates the conductor as a safety factor.

### current ratings

for Laminated and Bonded Planar Cables, or Extruded Cables, in Still Air

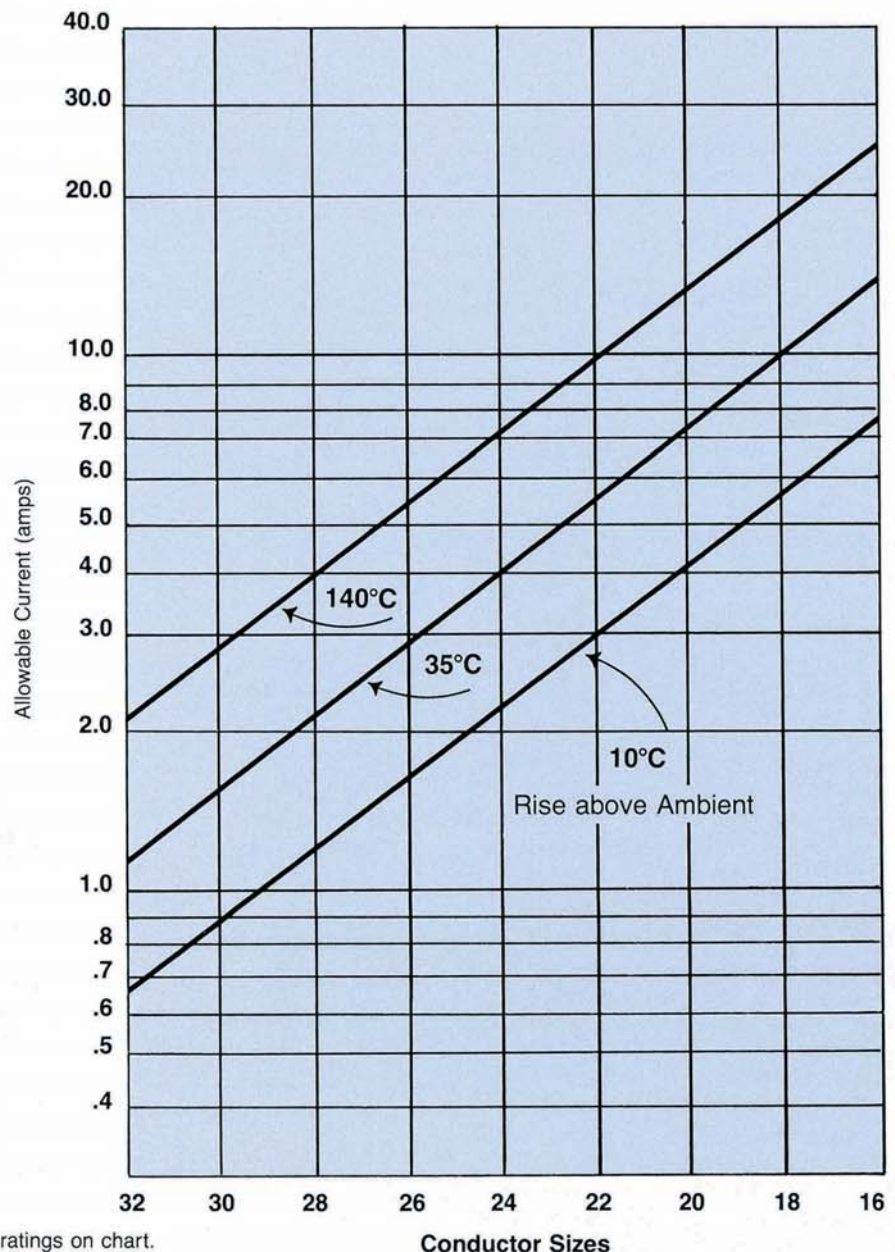

Note: No derating or safety factors applied to current ratings on chart.



# crosstalk

## crosstalk in planar cables

Crosstalk is the electrical disturbance caused in a quiet signal line when an adjacent line (or lines) is activated. For example, crosstalk occurs in common telephone signals (where you hear faint voices in the background or static buzzing) when weather conditions are right to induce a voltage gradient in a quiet line. In computer applications, excessive crosstalk can trigger sensitive logic circuits, usually a result of magnetic coupling of signals from other lines or sources (inductive or capacitive or a combination of both).

The magnitude of crosstalk on a given line is affected by:

1. Rise time of pulse in the signal line.
2. Geometry of signals and grounds.
3. Termination impedance of cable to circuitry.
4. Cable length.

## crosstalk tests

The most basic crosstalk test consists of driving one signal line in a cable and measuring the crosstalk on the adjacent signal line. Measurements are usually taken at the "near" or "backward" end (input end) and at the "far" or "forward" end (output end).

When a quiet line is probed at the driven or input end of the system, the voltage pickup seen is a pulse with the same rise time as the driving pulse, with a lower DC value, and a duration of twice the delay time of the transmission line. This is called Near End or Backwards Crosstalk.

When the quiet line is probed at the termination or output end, the pickup is a spike of opposite polarity from the driving line, and a time duration equal to about twice the output rise time. This is termed Far End or Forward Crosstalk.

While Near End Crosstalk is almost directly proportional to input peak voltage, Far End Crosstalk increases with cable length and faster pulse rise times.

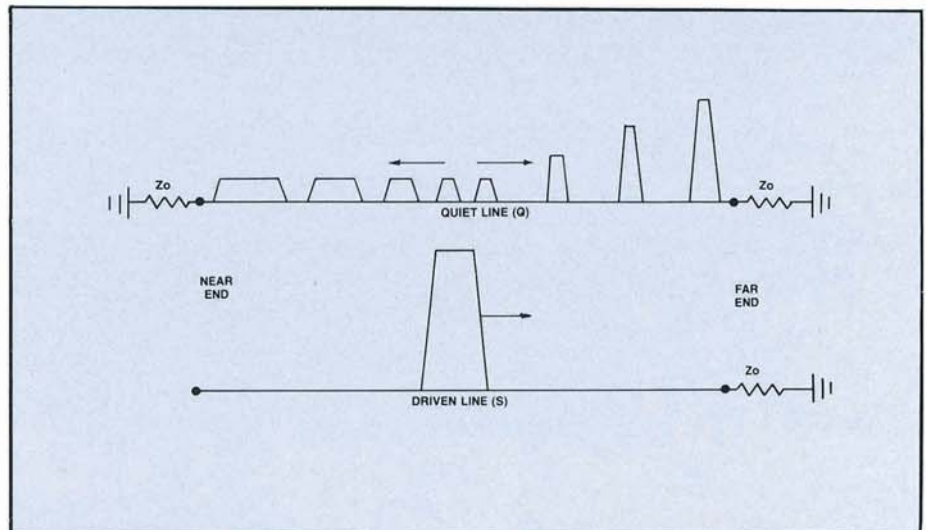
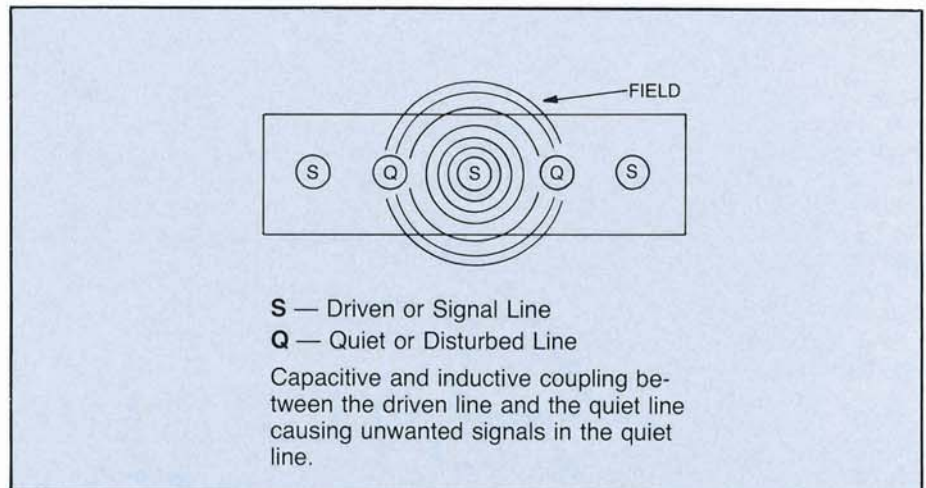

## Rise Time

The faster the pulse rises, the greater the far-end crosstalk. It is measured in nanoseconds ( $10^{-9}$ ). See curves of rise time vs. crosstalk for various planar cables.

## Configuration

Crosstalk can be reduced by adding ground lines between signal lines, using twisted pairs, adding a ground plane below conductors, increasing conductor spacing or various combinations of these techniques.

## Termination Impedance

Properly terminating a transmission line will reduce crosstalk, and can also reduce pulse reflections on the driven lines.

## Cable Length

Crosstalk increases as the signal line length increases.

## Stacked Crosstalk

The far and near end crosstalk when measured between layers of cable. It is best reduced by inserting dielectric spacers between layers.



# crosstalk

## Near End (Backward) Crosstalk vs. Rise Time

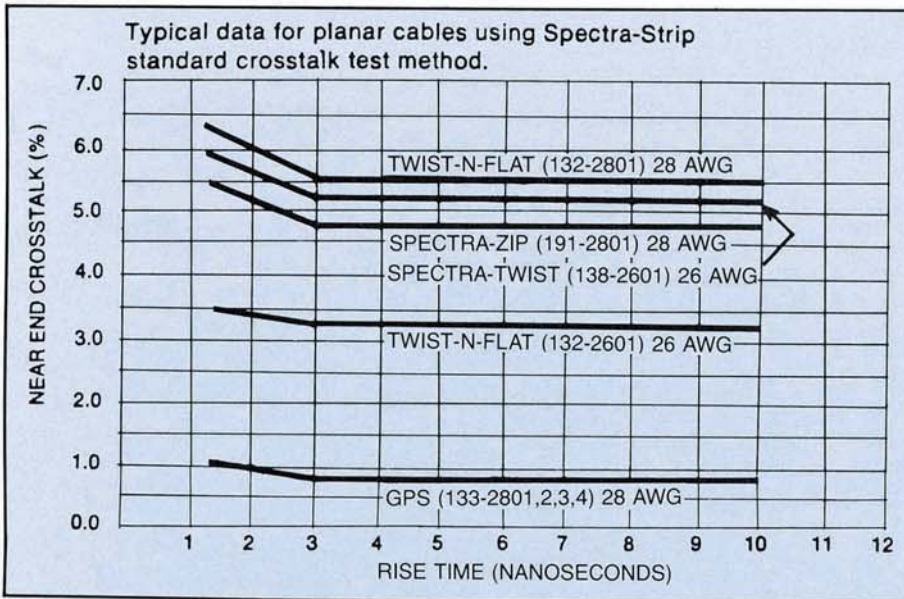

## Far End (Forward) Crosstalk vs. Rise Time

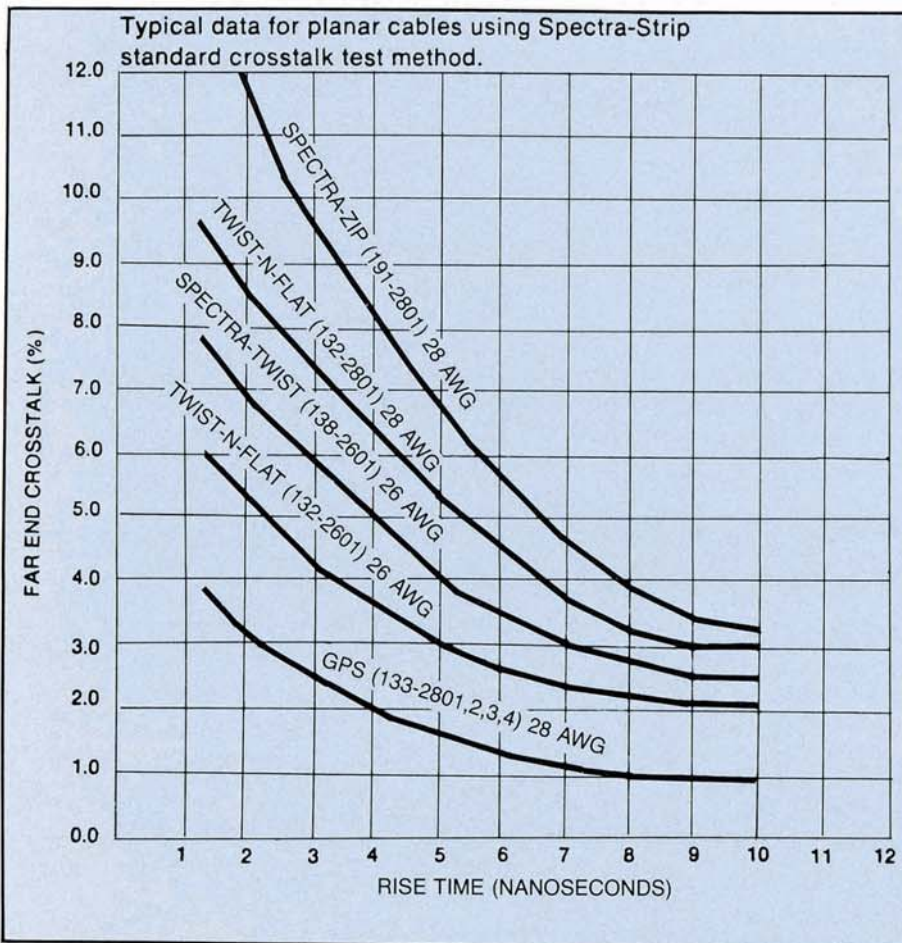

## reducing crosstalk

1. Reduce signal rise time. (see curves).
2. Reduce length of cable or signal line.
3. Utilize cable configurations:

**Relative Far End Crosstalk**

- Add Alternate Ground Wires 10
- Increase Ground Wire Size 9
- Increase Pitch (Spacing) 7
- Add Two Ground Wires 6
- Twisted Pairs 6
- Add Ground Plane 3
- Add Ground Plane and Ground Wires 2

## Spectra-Strip crosstalk standards

Spectra-Strip crosstalk tests utilize a standard cable length of 10 feet. Two driven lines and the quiet line (center) are terminated in their characteristic impedance and other lines left open circuit.

Typical data is compiled over a range of rise times with five (5) nanoseconds selected as the standard. Crosstalk in the quiet line is expressed as the percentage (%) of driven signal.

# standard agencies

## laminated planar cables

Spectra-Strip Part Number	Cable Type	Recognition		Laminate Mat'l.	UL/CSA Rating		Additional Information
		UL Style Number	CSA Designation		Temp. °C	Volt	
135-2801 135-2601 135-2401 135-2602 135-2402 135-2603 135-2604 135-2403 135-2201	Color Coded	2697	IA	PVC	80	300	CSA requires cable to be printed. USE: Internal wiring of electronic equipment.
		20130			105	300	
132-2801 132-2601	Twist 'N' Flat	2697	IA	PVC	80	300	CSA requires cable to be printed. USE: Internal wiring of electronic equipment.
138-2601 138-2801 138-2401 139-2601	Twisted Pair	20126	IA	PVC	80	300	CSA requires cable to be printed. USE: Internal wiring of electronic equipment.
		20130			105	300	
134-2801	Ground Plane	2638	IA	PVC	80	300	CSA requires cable to be printed. USE: Internal wiring of electronic equipment.
144-2601 144-2401	Gray PVC	2651	—	PVC	105	300	Uninsulated wires. USE: Internal wiring Class 2 circuits.
191-2801 191-3001 191-2802 191-2601 191-2602	Spectra-Zip	2651	IA	PVC Extruded	105	300	Uninsulated wires, tinned or bare copper. USE: Internal wiring of electronic equipment. CSA requires cable to be printed.
133-2801 133-2802 133-2803 133-2804	Ground Plane	2682	IA	PVC	105	300	Uninsulated wires, tinned or bare copper. USE: Internal wiring of electronic equipment. CSA requires cable to be printed.

Dimensions and characteristics subject to change without notice.



# standard agencies

## laminated planar cables

Spectra-Strip Part Number	Cable Type	Recognition		Laminate Mat'l.	UL/CSA Rating		Additional Information
		UL Style Number	CSA Designation		Temp. °C	Volt	
135-2801 135-2601 135-2401 135-2602 135-2402 135-2603 135-2604 135-2403 135-2201	Color Coded	2697	IA	PVC	80	300	CSA requires cable to be printed. USE: Internal wiring of electronic equipment.
		20130			105	300	
132-2801 132-2601	Twist 'N' Flat	2697	IA	PVC	80	300	CSA requires cable to be printed. USE: Internal wiring of electronic equipment.
138-2601 138-2801 138-2401 139-2601	Twisted Pair	20126	IA	PVC	80	300	CSA requires cable to be printed. USE: Internal wiring of electronic equipment.
		20130			105	300	
134-2801	Ground Plane	2638	IA	PVC	80	300	CSA requires cable to be printed. USE: Internal wiring of electronic equipment.
144-2601 144-2401	Gray PVC	2651	—	PVC	105	300	Uninsulated wires. USE: Internal wiring Class 2 circuits.
191-2801 191-3001 191-2802 191-2601 191-2602	Spectra-Zip	2651	IA	PVC Extruded	105	300	Uninsulated wires, tinned or bare copper. USE: Internal wiring of electronic equipment. CSA requires cable to be printed.
133-2801 133-2802 133-2803 133-2804	Ground Plane	2682	IA	PVC	105	300	Uninsulated wires, tinned or bare copper. USE: Internal wiring of electronic equipment. CSA requires cable to be printed.

Dimensions and characteristics subject to change without notice.

## standard agencies

### bonded ribbon cable — PVC

UL Listings		Temp. Rating (°C)	Voltage Rating	Additional Information
Cable Style No.	Conductor <sup>(2)</sup> Style No.			
2648	1429	80	150	IPVC (BXL) <sup>(4)</sup>
2444	1095	80	300	-----
2476 <sup>(1)</sup>	1061	80	300	SR-PVC
2555 <sup>(1)</sup>	1007	80	300	PVC
2473 <sup>(1)</sup>	1011	80	600	PVC
2500 <sup>(1)</sup>	1013	90	600	PVC
2647	1430	105	300	IPVC (CXL) <sup>(4)</sup>
2474 <sup>(1)</sup>	1015	105	600	PVC
2649	1431	105	600	IPVC (DXL) <sup>(4)</sup>
2697 <sup>(1)</sup>	Specified <sup>(3)</sup>	80	300	Cable can be comprised of any conductor complying with UL subject 758.
2698	Specified <sup>(3)</sup>	80	600	" " "
2695	Specified <sup>(3)</sup>	90	300	" " "
2696	Specified <sup>(3)</sup>	90	600	" " "
2693	Specified <sup>(3)</sup>	105	300	" " "
2694	Specified <sup>(3)</sup>	105	600	" " "
20126	SR-PVC	80	300	" " "

- (1) Also CSA Certified — must be surface printed.  
(2) Conductor UL Style No. determines cable style no.  
(3) Specified refers to conductor style no. required by user.  
(4) IPVC — Irradiated Polyvinyl Chloride.

### Mil-W-16878D insulation summary table

Insul. Type	Insulation Material	Temp. Rating (°C)	Voltage Rating
B	PVC	105	600
C	PVC	105	1000
D	PVC	105	3000
E	TFE (Teflon)	200	600
EE	TFE (Teflon)	200	1000
ET	TFE (Teflon)	200	250
F	Silicone	200	600
FF	Silicone	200	1000
FFW	Silicone	200	1000
J	Polyethylene	75	600
K	FEP (Teflon)	200	600
KK	FEP (Teflon)	200	1000
KT	FEP (Teflon)	200	250



# standard agencies

## hook-up wire, PVC insulation

Listings		Temp. Rating (°C)	Voltage Rating	Thickness (Inches)	Wall Additional Information
UL Style Number	CSA Recognition				
1568	—	80	150	.009	Class 2 Circuits
1007	PVC	80	300	.016	—
1061	SR-PVC	80	300	.009	Semi-Rigid Compound
1095	—	80	300	.012	—
1195	SR-PVC	80	300	.015	Semi-Rigid Compound
1011	PVC	80	600	.031	CSA Rating 90°C
1013	PVC	90	600	.031	—
1569	PVC	105	300	.016	—
1015	PVC	105	600	.031	—
1731	—	105	300	.010	—

## UL/CSA summary

Cable	Std. P/N (CSA P/N)	UL/CSA
Spectra-Guard	151-2811-XXX 151-2831-XXX (For CSA Use 151-2811-1XX) (For CSA Use 151-2831-1XX)	UL Listed CL2 CSA AWM I/II 105C 300V FT-1
Spectra-Zip	191-2801-XXX (For CSA Use 191-2801-1XX)	UL Style 2651 CSA AWM I 105C 300V FT-1
3C	135-2801-XXX (For CSA Use 135-2801-2XX)	UL Style 2697 CSA AWM I 80C 300V FT-1
Twist'N'Flat	132-2801-XXX (For CSA Use 132-2801-1XX)	UL Style 2697 CSA AWM I 80C 300V FT-1
Spectra-Twist	138-2601-XXX (For CSA Use 138-2601-1XX)	UL Style 20126 CSA AWM I 80C 300V FT-1
Spectra-GP	133-280X-XXX (For CSA Use 133-280X-1XX)	UL Style 2682 CSA AWM I 105C 300V FT-1
Spectra-Bond	111-XXXX-XXX (For CSA Use 111-XXXX-3XX)	UL Style 2697 CSA AWM I 80C 300V FT-1 CSA AWM I 80C 300V FT-1
Spectra-Flex	112-XXXX-XXX (For CSA Use 112-XXXX-3XX)	UL Style 2697 CSA AWM I 80C 300V FT-1
Round'N'Flat Round Twist'N' Flat	159-XXXX-XXX 169-XXXX-XXX	UL Listed CL2 CSA AWM I/II 105C 300V FT-1
SCSI	167-XXXX-XXX	UL Listed CL2 CSA AWM I/II 75C 300V FT-4