

Thor™ VM1

Vehicle-Mounted Computer

Microsoft® Windows® Embedded Standard 2009 Operating System

Reference Guide

Disclaimer

Honeywell International Inc. ("HII") reserves the right to make changes in specifications and other information contained in this document without prior notice, and the reader should in all cases consult HII to determine whether any such changes have been made. The information in this publication does not represent a commitment on the part of HII.

HII shall not be liable for technical or editorial errors or omissions contained herein; nor for incidental or consequential damages resulting from the furnishing, performance, or use of this material.

This document contains proprietary information that is protected by copyright. All rights are reserved. No part of this document may be photocopied, reproduced, or translated into another language without the prior written consent of HII.

© 2011-2012 Honeywell International Inc. All rights reserved.

Web Address: www.honeywellaidc.com

RFTerm is a trademark or registered trademark of EMS Technologies, Inc. in the United States and/or other countries.

Microsoft® Windows, ActiveSync®, MSN, Outlook®, Windows Mobile®, the Windows logo, and Windows Media are registered trademarks or trademarks of Microsoft Corporation.

Intel® and Atom™ are trademarks or registered trademarks of Intel Corporation or its subsidiaries in the United States and other countries.

Summit Data Communications, the Laird Technologies Logo, the Summit logo, and "Connected. No Matter What" are trademarks of Laird Technologies, Inc.

The Bluetooth® word mark and logos are owned by the Bluetooth SIG, Inc.

Symbol® is a registered trademark of Symbol Technologies. MOTOROLA, MOTO, MOTOROLA SOLUTIONS and the Stylized M Logo are trademarks or registered trademarks of Motorola Trademark Holdings, LLC and are used under license.

RAM® and RAM Mount™ are both trademarks of National Products Inc., 1205 S. Orr Street, Seattle, WA 98108.

Freefloat, Freefloat Link*One and Freefloat Access*One are trademarks of Freefloat, Mölndalsvägen 30B, SE-412 63Gothenburg, Sweden.

Qualcomm® is a registered trademark of Qualcomm Incorporated. Gobi is a trademark of Qualcomm Incorporated.

OneClick Internet is WebToGo's patented connection manager customized for Honeywell mobile devices. OneClick Internet documentation is copyright 2010 by WebToGo and modified by Honeywell with WebToGo's express permission.

Verizon® is a registered trademark of Verizon Trademark Services LLC.

T-MOBILE® is a registered trademark of Deutsche Telekom AG.

AT&T® is a registered trademark of AT&T Intellectual Property.

PenMount, and the Pen Mount logo are registered trademarks of Salt International Corporation, Taipei, Taiwan, R.O.C.

Acrobat® Reader © 2012 with express permission from Adobe Systems Incorporated.

Other product names or marks mentioned in this document may be trademarks or registered trademarks of other companies and are the property of their respective owners.

Patents

For patent information, please refer to www.honeywellaidc.com/patents.

Limited Warranty

Refer to www.honeywellaidc.com/warranty_information for your product's warranty information.

Table of Contents

Chapter 1: Introduction	1-1
About this Guide	1-1
Components	1-2
Front View	1-2
Back View with Quick Mount Smart Dock	1-3
Access Panels	1-3
Chapter 2: Hardware	2-1
System Hardware	2-1
802.11a/b/g/n Wireless Client	2-1
Central Processing Unit	2-1
Input/Output Components	2-2
System Memory	2-2
Video Subsystem	2-2
Audio Interface	2-2
Card Slots	2-2
CompactFlash (CF) Slot	2-2
Secure Digital (SD) Slot	2-2
Bluetooth LXEZ Pair	2-3
WWAN	2-3
GPS	2-3
Power	2-4
Vehicle DC Power Supply	2-4
External AC Power Supply	2-4
Uninterruptible Power Supply	2-4
Backup Battery	2-5
Fuse	2-5
Power Management Modes	2-6
Full On Mode	2-6
Standby Mode	2-6
System Standby Wakeup Events	2-6
Hibernate Mode	2-6
System Hibernate Wakeup Events	2-6
Off Mode	2-6
Power Controls	2-7
Power Switch	2-7
Thor VM1 Power Button	2-7
Auto On Behavior	2-8

Standard	2-8
Ignition Control.....	2-8
Auto-On.....	2-8
External Connectors.....	2-9
Serial Connector (COM1 and COM2).....	2-10
Pinout.....	2-10
Screen Blanking.....	2-11
Serial Cable.....	2-11
Screen Blanking Box.....	2-12
Screen Blanking with Switch.....	2-12
USB Connector.....	2-13
USB Dongle Cable.....	2-14
D9 Male Connector.....	2-14
USB Host Connector.....	2-15
USB Client Connector.....	2-15
Power Supply Connector.....	2-16
CANbus / Audio Connector.....	2-17
Headset Adapter Cable.....	2-18
D15 Female Connector.....	2-18
Quick Connect Headset Connector.....	2-19
CANbus Cable.....	2-20
D15 Female Connector.....	2-20
9-Pin J1939 (Deutsch) Connectors.....	2-21
Antenna Connections.....	2-22
Antenna Connector.....	2-22
Internal WiFi Antenna.....	2-22
Vehicle Remote Antenna.....	2-22
Keyboard Options.....	2-23
64-Key QWERTY Keyboard.....	2-23
IBM 3270 Overlay.....	2-24
IBM 5250 Overlay.....	2-25
Keyboard LEDs.....	2-26
Shift LEDs.....	2-26
Secondary Keys LED.....	2-26
Ctrl and Alt Key LEDs.....	2-26
USB Keyboard / Mouse.....	2-26
LED Functions.....	2-27
System LEDs.....	2-27
SYS (System Status) LED.....	2-28
UPS Status LED.....	2-29

External Power Present.....	2-29
External Power Not Present.....	2-29
SSD (Solid State Drive) LED.....	2-29
Connection LEDs.....	2-30
WWAN LED.....	2-30
WiFi LED.....	2-30
Bluetooth LED.....	2-30
Keyboard LEDs.....	2-31
2nd LED.....	2-31
Shift LEDs.....	2-31
Ctrl LED.....	2-31
Alt LED.....	2-32
Display.....	2-33
Touch Screen.....	2-33
Touch Screen Defroster.....	2-33
Screen Blanking.....	2-33
Display Backlight Control.....	2-33
Disconnect UPS Battery.....	2-34
Install SD Card.....	2-36
Install SIM Card.....	2-38
Field Replaceable Front Panel.....	2-40
Replace Front Panel.....	2-40
Field Replaceable UPS Battery.....	2-42
Replace UPS Battery.....	2-42
Chapter 3: Software.....	3-1
Microsoft Windows Setup and Configuration.....	3-1
Drive C Folder Structure.....	3-2
Software Loaded on Drive C.....	3-2
Programs Loaded on Drive C.....	3-3
LXE RFTerm (Optional).....	3-3
Summit Client Utility.....	3-3
Freefloat Link*One Wedge (Optional).....	3-3
Freefloat Access*One TE (Optional).....	3-3
Control Panel.....	3-4
About.....	3-4
AutoOn.....	3-5
Standard.....	3-5
Ignition Control.....	3-5
Auto-On.....	3-6

Bluetooth	3-7
Bluetooth Devices	3-9
Discover	3-10
Stop Button	3-10
Bluetooth Device List	3-11
Clear Button	3-11
Bluetooth Device Menu	3-12
Right-Click Menu Options	3-12
Bluetooth Device Properties	3-12
Settings	3-13
Turn Off Bluetooth	3-13
Options	3-14
Reconnect	3-15
Options	3-16
About	3-18
Using Bluetooth	3-19
Initial Configuration	3-19
Subsequent Use	3-20
Bluetooth Indicators	3-21
Bluetooth Bar Code Reader Setup	3-22
Thor VM1 with Label	3-22
Thor VM1 without Label	3-23
Bluetooth Beep and LED Indications	3-24
Bluetooth Printer Setup	3-24
Easy Pairing and Auto-Reconnect	3-24
Display	3-25
Power Options	3-26
Power Schemes	3-26
Power Meter	3-27
Advanced	3-28
Hibernate	3-29
Screen Control	3-30
Screen Blanking	3-31
Automatic Brightness Control	3-32
Keypad Backlight	3-32
Current Level	3-32
Defroster Control	3-32
Screen Rotation	3-33
Sounds	3-34
User Accounts	3-35

Wi-Fi.....	3-35
Bar Code Readers.....	3-36
Scanner Wedge.....	3-36
Touch Screen Calibration.....	3-37
BIOS.....	3-38
Accessing the BIOS Setup.....	3-38
Boot Order.....	3-38
Exiting BIOS Setup.....	3-38
The Thor VM1 Recovery DVD.....	3-39
Upgrading the Thor VM1.....	3-39
Chapter 4: Wireless Network Connections	4-1
Summit Wireless Network Configuration.....	4-1
Important Notes.....	4-1
Summit Client Utility.....	4-2
Help.....	4-2
Summit Tray Icon.....	4-2
Wireless Zero Config Utility.....	4-3
How To: Use the Wireless Zero Config Utility.....	4-3
How to: Switch Control to SCU.....	4-3
Main Tab.....	4-4
Admin Login.....	4-5
Profile Tab.....	4-6
Buttons.....	4-7
Profile Parameters.....	4-8
Status Tab.....	4-10
Diags Tab.....	4-11
Global Tab.....	4-12
Custom Parameter Option.....	4-13
Global Parameters.....	4-14
Logon Options.....	4-17
Single Signon.....	4-18
Pre-Logon Connection.....	4-18
Sign-On vs. Stored Credentials.....	4-20
How to: Use Stored Credentials.....	4-20
How to: Use Sign On Screen.....	4-20
How to: Use Windows Username and Password.....	4-21
Windows Certificate Store vs. Certs Path.....	4-22
User Certificates.....	4-22
Root CA Certificates.....	4-22

How To: Use the Certs Path	4-22
How To: Use Windows Certificate Store	4-22
Configuring the Profile	4-24
No Security	4-25
WEP	4-26
LEAP	4-28
PEAP/MSCHAP	4-30
PEAP/GTC	4-32
WPA/LEAP	4-34
EAP-FAST	4-36
EAP-TLS	4-38
WPA PSK	4-41
Certificates	4-42
Generating a Root CA Certificate	4-43
Installing a Root CA Certificate	4-46
Generating a User Certificate	4-48
Exporting a User Certificate	4-50
Installing a User Certificate	4-53
OneClick Internet	4-55
Preparing for Initial Use on the Thor VM1	4-55
Install SIM Card	4-55
Load Firmware	4-55
Activation	4-55
Using OneClick Internet	4-58
How To: Connection Management	4-58
Menu Buttons	4-59
Radio Button	4-59
Statistics Button	4-59
Update Button	4-59
Help Button	4-59
Settings Button	4-60
Profile Tab	4-61
Buttons	4-62
Parameters	4-62
Network Tab	4-63
Network with SIM Card	4-63
CDMA Network	4-65
History Tab	4-66
PIN Tab	4-66
Activate/Deactivate PIN	4-66

Change PIN.....	4-67
Info Tab.....	4-68
Firmware Tab.....	4-69
Activation on CDMA.....	4-70
General Tab.....	4-71
Application Tab.....	4-72
Application Buttons.....	4-73
SMS.....	4-73
Folder.....	4-74
Settings.....	4-74
New SMS.....	4-74
Reply.....	4-75
Forward.....	4-75
Move SMS.....	4-75
Delete.....	4-75
Send/Receive.....	4-75
Addresses.....	4-75
Web Browser.....	4-76
Email.....	4-76
GPS.....	4-76
About.....	4-78
System Requirements.....	4-78
Supported Languages.....	4-78
Installing or Upgrading OneClick Internet.....	4-78
Installation.....	4-79
OneClick Internet Connection Manager.....	4-82
Connection Management.....	4-82
Information Buttons.....	4-83
Chapter 5: Key Maps.....	5-1
64-Key QWERTY Keypad Key Map.....	5-1
IBM Terminal Emulation.....	5-6
IBM 3270.....	5-6
IBM 5250.....	5-7
Chapter 6: Technical Specifications.....	6-1
Thor VM1.....	6-1
Quick Mount Smart Dock.....	6-2
Dimensions.....	6-2
Thor VM1.....	6-2
Quick Mount Smart Dock.....	6-2

Environmental Specifications.....	6-3
Thor VM1 and Quick Mount Smart Dock.....	6-3
Network Card Specifications.....	6-4
Summit 802.11 a/b/g/n.....	6-4
Bluetooth.....	6-4
Chapter 7: Technical Assistance.....	7-1

Chapter 1: Introduction

The Thor VM1 Vehicle Mount Computer (VMC) is a rugged, vehicle mounted computer running a Microsoft® Windows® Embedded Standard 2009 operating system and capable of wireless data communications from a fork-lift truck or any properly configured vehicle. Wireless communications are supported over a 802.11 WLAN network and, optionally, over a WWAN network. The optional Bluetooth® module supports Bluetooth printers and scanners.

<p>Caution</p> 	<p>Before shipping the Thor VM1, the internal UPS battery must be disconnected.</p>
--	---

The Thor VM1 is designed for use with a vehicle Quick Mount Smart Dock. The dock installs in the vehicle and connects to vehicle power. The dock provides conditioned input power for the Thor VM1. Peripheral connections are on the dock. The Thor VM1 is designed to easily be removed from the dock with a latch on the lower rear of the Thor VM1 housing. Since the dock remains attached to the vehicle, the Thor VM1 computer can easily be moved from one vehicle equipped with a Quick Mount Smart Dock to another vehicle equipped with a Quick Mount Smart Dock.

The Thor VM1 contains a UPS battery which, when fully charged, can power the Thor VM1 for a minimum of 30 minutes. This can be when the Thor VM1 is not attached to a Quick Mount Smart Dock or when the Thor VM1 is attached to a dock but the vehicle power is interrupted, such as when the vehicle battery is being changed.

Contact [Technical Assistance](#) for information on the latest upgrades for your Thor VM1.



About this Guide

This Thor VM1 Reference Guide provides instruction for the system administrator to follow when configuring a Thor VM1.

This reference guide has been developed for a Thor VM1 with a Microsoft® Windows® Embedded Standard 2009 operating system.

Components

Front View

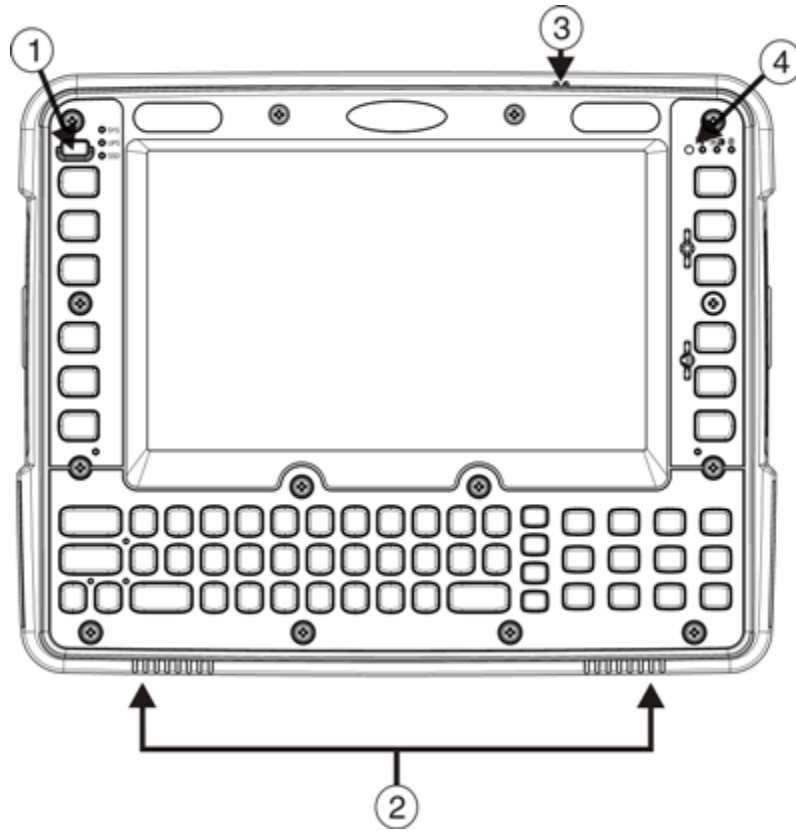

1. Power Button
2. Speakers
3. Microphone
4. Ambient Light Sensor

Back View with Quick Mount Smart Dock

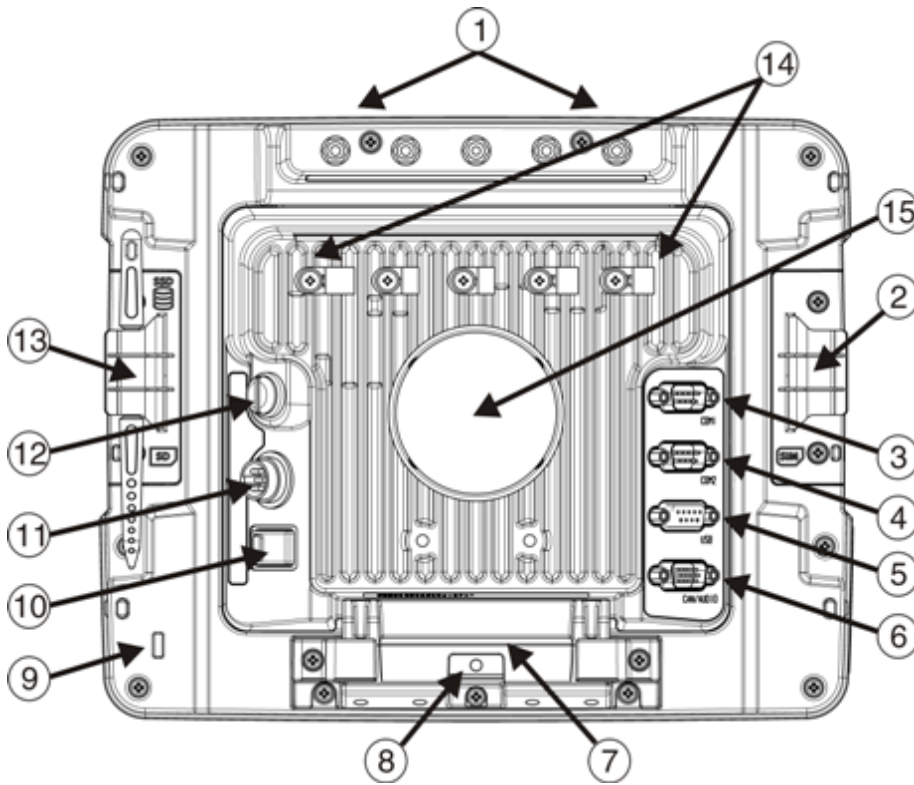

1. Antenna Connectors (on Thor VM1)
2. SIM card Access Panel (on Thor VM1)
3. COM1 Connector (on Dock)
4. COM2 Connector (on Dock)
5. USB Connector (on Dock)
6. CAN/Audio Connector (on Dock)
7. Quick Release Handle (On Thor VM1)
8. Provision for Padlock (on Thor VM1)
9. Provision for Laptop Security Cable (on Thor VM1)
10. Power Switch (on Dock)
11. Power Connector (on Dock)
12. Fuse (on Dock)
13. SD Card Access Panel (On Thor VM1)
14. Strain Relief Clamps (on Dock)
15. RAM Ball (on Dock)

Access Panels

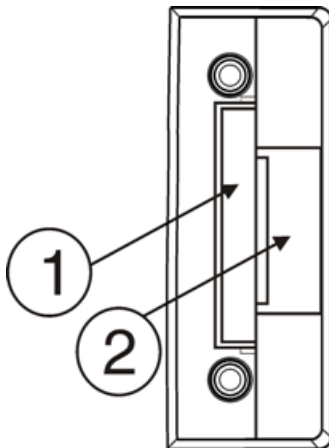

Access Panel Door is labeled with **SSD** and **SD**.

1. CompactFlash Hard Drive
2. SD (Secure Digital) Memory Card Slot

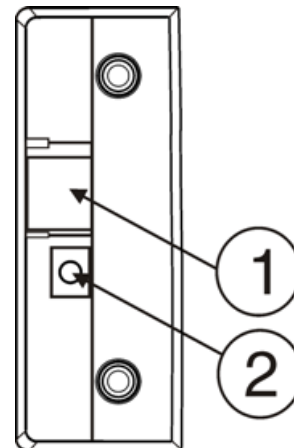

Access Panel Door is labeled with **SIM**.

1. SIM card slot for WWAN radio
2. UPS battery disconnect



Chapter 2: Hardware

System Hardware

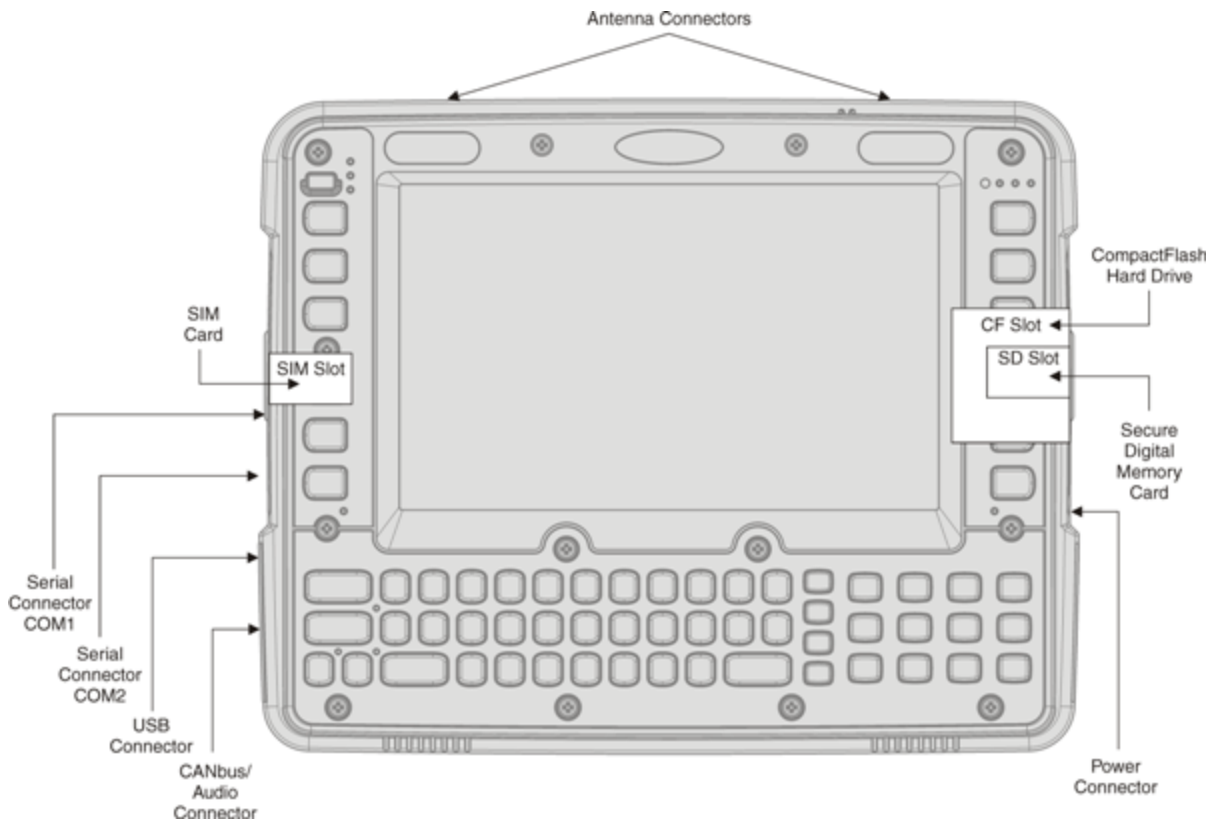

802.11a/b/g/n Wireless Client

The Thor VM1 has an 802.11a/b/g/n network card that supports diversity with two internal or external antennas. Power management for the network card is configured with the [Summit Client Utility](#).

Central Processing Unit

The CPU is a 1.6 GHz Intel Atom processor. The operating system is Microsoft Windows Embedded Standard 2009. The OS image is stored on an internal CompactFlash card and is loaded into DRAM for execution.

Input/Output Components

The Thor VM1 supports the following I/O components of the core logic:

- Two 9-pin RS-232 serial ports configured as COM1 and COM2.
- One slot for SD memory card.
- CompactFlash (CF) drive.
- Integrated keyboard.
- Ports available via dongle cable:
 - USB Host port
 - USB Client port (Not available with Windows Embedded Standard OS)
 - CANbus
 - Audio

System Memory

Main system memory is 2GB SDRAM.

Video Subsystem

The Thor VM1 video subsystem consists of a color TFT display. The video subsystem complies with the VESA VL bus standard. The resolution of this display is 800 x 480 pixels. This resolution complies with the WVGA graphics industry standard.

The display supports screen blanking to eliminate driver distraction when the vehicle is in motion.

Audio Interface

Speakers are located on the bottom front of the Thor VM1. An headset adapter cable provides a connection for headset operation. When a headset is plugged into the adapter cable, the main speakers are disabled.

A microphone is located at the upper right of the Thor VM1 display, near the Thor VM1 emblem. When a headset is plugged into the adapter cable, the internal microphone is disabled.

Card Slots

CompactFlash (CF) Slot

The CF ATA slot is not hot swappable. The Thor VM1 must be powered down to insert or remove an ATA card. Since the operating system is stored on the CF ATA card, the Thor VM1 cannot operate without the ATA card.

Secure Digital (SD) Slot

The SD slot accepts an SD memory card. The SD card is hot swappable.

Bluetooth LXEZ Pair

The Thor VM1 contains Bluetooth version 2.0 with Enhanced Data Rate (EDR) up to 3.0 Mbit/s over the air. Bluetooth device connection (or pairing) can occur at distances up to 32.8 ft (10 meters) Line of Sight. The wireless client retains wireless connectivity while Bluetooth is active.

The user cannot select PIN authentication or encryption on connections from the Thor VM1. However, the Thor VM1 supports authentication requests from pairing devices. If a pairing device requests authentication or encryption, the Thor VM1 displays a prompt for the PIN or passcode. Maximum encryption is 128 bit. Encryption is based on the length of the user's passcode.

Bluetooth simultaneously supports one printer as a slave Bluetooth device and one scanner, either as a slave or as a master Bluetooth device.

- The LED on the Bluetooth scanner illuminates during a scanning operation.
- Bar code data captured by the Bluetooth scanner can be manipulated by the settings in the optional Freefloat Link*One application.
- Multiple beeps may be heard during a bar code scan using a mobile Bluetooth scanner; beeps from the mobile Bluetooth scanner as the bar code data is accepted/rejected, and other beeps from the Thor VM1 during final bar code data manipulation.

WWAN

WWAN (Wireless Wide Area Networking) is available on the Thor VM1. A slot is provided for a SIM card.

GPS

GPS (Global Positioning System) is available on the Thor VM1.

Power

Vehicle DC Power Supply

Vehicle power input for the Thor VM1 dock is 10V to 60V DC and is accepted without the need to perform any manual operation within the Thor VM1 dock. The dock provides a conditioned power output for the Thor VM1. By using a specified DC-to-DC adapter, input voltage of 72-144V DC nominal can be accepted.

If 10 to 60V DC power is not available – for example, in an office environment – an optional external Universal Input Power Supply can be used to convert AC wall power to an appropriate DC level.

Power input is fused for protection and the fuse is externally accessible.

External AC Power Supply

AC to DC power input for the Thor VM1 is delivered to the Quick Mount Smart Dock via an optional external power supply and adapter cable. One end of the adapter cable attaches to the dock and the other end is a barrel connector for the output cable from the adapter.

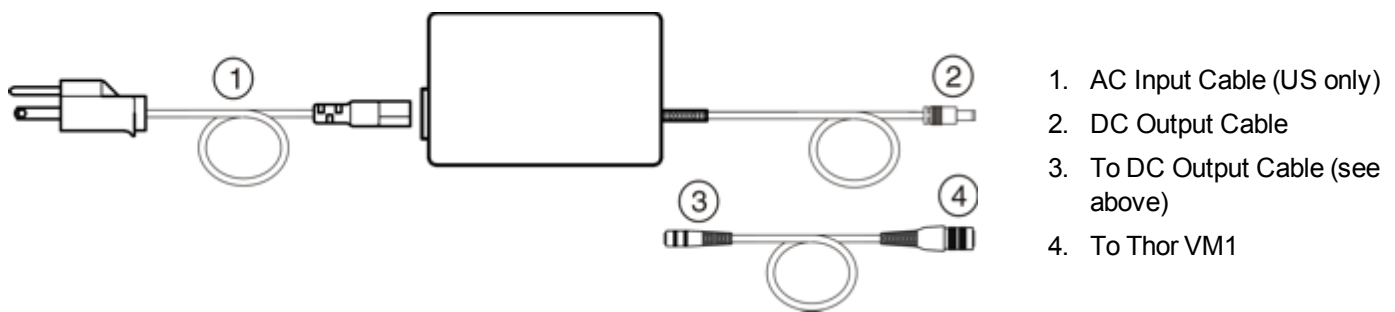

In North America, this unit is intended for use with a UL Listed ITE power supply with output rated 12 – 48 VDC, minimum 15 W. Outside North America, this unit is intended for use with an IEC certified ITE power supply with output rated 12 – 48 VDC, minimum 15 W.

The external power supply may be connected to either a 120V, 60Hz supply or, outside North America, to a 230V, 50Hz supply, using the appropriate detachable cordset. In all cases, connect the external AC supply to a properly grounded source of supply provided with maximum 15 Amp overcurrent protection (10 Amp for 230V circuits).

Please refer to the wiring instructions, including appropriate cautions and warnings, in the *Thor VM1 User Guide*.

Uninterruptible Power Supply

The Thor VM1 contains an internal UPS battery.

The UPS battery is automatically charged when the Thor VM1 is placed in a powered dock.

- A fully discharged UPS battery recharges in under 4 hours when the Thor VM1 is in a powered dock.
- Charging of the UPS battery continues during power management of the Thor VM1.
- If the UPS battery is not charged before the timeout expires, the **fault LED** is lit.
- If the UPS battery cannot be charged due to a temperature extreme, the **fault LED** is lit. Move the Thor VM1 to a different location to charge the UPS battery.

When external power is removed, the UPS automatically powers the Thor VM1 with no user intervention. When running on UPS power, the power management timeouts may be different than when vehicle power is applied.

The UPS allows the Thor VM1 to continue operation when not mounted in a dock or when the vehicle battery is being swapped. The UPS battery is designed to power the Thor VM1 for a minimum of 30 minutes at temperatures of -20°C (-4°F) or greater. For the extended temperature version of the Thor VM1, the UPS provides a minimum of 10 minutes of operation below -20°C (-4°F), up to -30°C (-22°F).

If operating on UPS power and the UPS battery becomes critically low, the Thor VM1 performs a controlled shutdown.

If there is no external power available, there must be 10% or greater power in the UPS battery or the Thor VM1 does not power on.

The UPS status LED and the Battery Control Panel can be used to monitor the state of the UPS battery.

The UPS battery can be [replaced by the user](#).

Backup Battery

The Thor VM1 has a permanent Lithium battery installed to maintain time, date and CMOS setup information for a minimum of 90 days. The lithium battery is not user serviceable and should last five years with normal use before it requires replacement.

Note: The backup battery should only be changed by authorized service personnel.

Fuse

The Thor VM1 uses an 8A time delay (slow blow), fuse that is externally accessible and user replaceable. The fuse is located on the back of the Quick Mount Smart Dock. The fuse is accessed by unscrewing the cap as indicated below.

Should it need replacement, replace with same size, rating and type of fuse – Littelfuse 0215008.MXP or equivalent.

Fuse has voltage on it even when power is off. Always disconnect input power before changing the fuse.

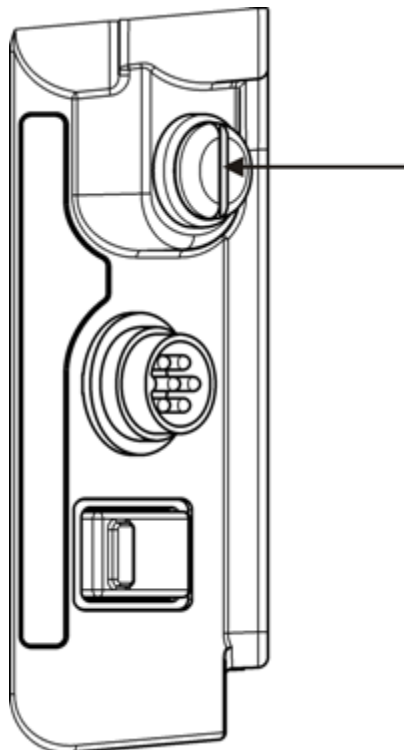

Power Management Modes

The Thor VM1 has four power modes: On, Standby, Hibernate and Off.

Full On Mode

When the Thor VM1 is attached to either vehicle power or an external power supply or is operating from the UPS battery and the power button is pressed, the Thor VM1 is in the On mode. In this mode, the keypad, touch screen and any attached peripherals such as a scanner function normally. The display remains on until the display, standby or hibernate timer (if enabled) expires.

When in Full On mode, the status LED is solid green.

If the Thor VM1 is Full On, a press of the power button can be configured to put the unit in Standby. See [Control Panel > Power Options > Advanced](#).

Standby Mode

When the standby timer expires without a primary event occurring, the Thor VM1 transitions to standby mode. Pressing the Power button exits Standby mode and transitions the Thor VM1 to Full On.

When in Standby Mode, the status LED:

- blinks green very slowly if external power is attached.
- is off if external power is not attached.

System Standby Wakeup Events

The following events transition the Thor VM1 from Standby to Full On Mode:

- Pressing and releasing the Power button

Hibernate Mode

When the Thor VM1 enters hibernate mode, all LEDs are off. Pressing the Power button returns the Thor VM1 to Full On. By default, Hibernate mode is not enabled.

When in Hibernate Mode, the status LED:

- blinks green very slowly if external power is attached.
- is off if external power is not attached.

System Hibernate Wakeup Events

The following event transition the Thor VM1 from Standby to Full On Mode:

- Pressing and releasing the Power button.

Off Mode

The Thor VM1 turns off if the user presses the power button when the Thor VM1 is On. The Thor VM1 is also off when it is not connected to a power source and the UPS battery is depleted. However, an internal Real Time Clock (RTC) powered by an internal battery maintains the date and time while the Thor VM1 is off.

Power Controls

Power Switch

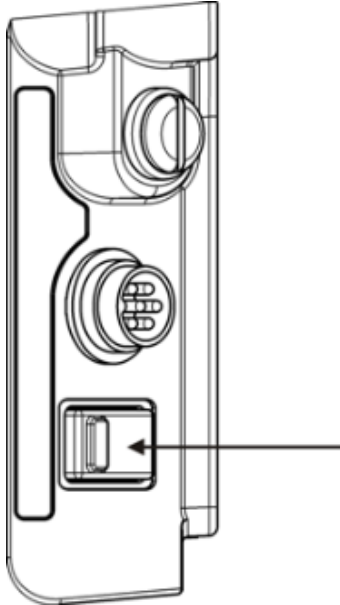

After all cables are connected, the Thor VM1 can be powered on.

There is a power switch located on the back of the Quick Mount Smart Dock. The power switch is a rocker switch.

The power switch has a raised bump to identify the switch position even when it is hidden from view. When the side of the switch with the raised bump is pressed, the power switch is On. If the Dock is connected to external power, the Dock delivers power to the Thor VM1.

Thor VM1 Power Button

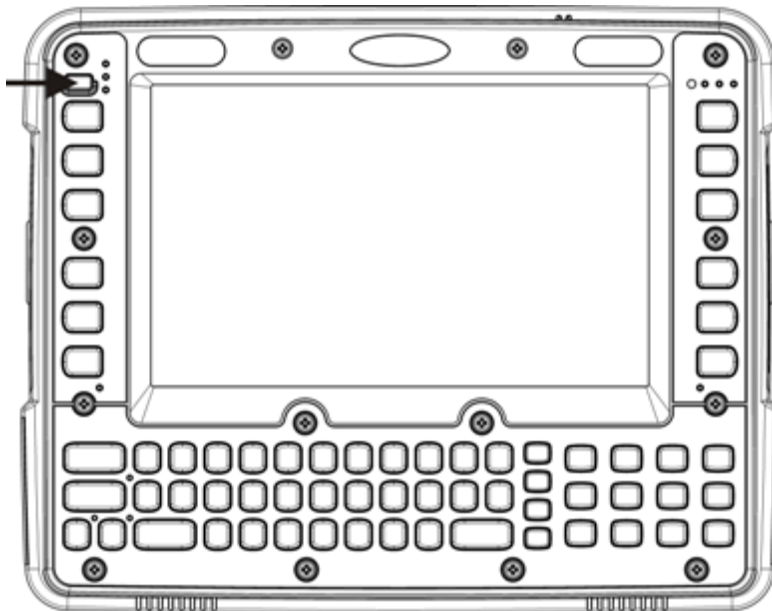

The [power button](#) is located at the bottom left of the Thor VM1.

If the Thor VM1 is Off, pressing the power button starts the power up sequence.

Note: This assumes that the Thor VM1 is docked in a powered Quick Mount Smart Dock or that the internal UPS battery has a sufficient charge to power the Thor VM1. If no external power is available and the UPS battery does not have a charge, pressing the power button causes no action.

If the Thor VM1 is On, pressing the power button performs the option selected in the Advanced tab of the [Power](#) control panel:

- Ignore power button press
- Prompt the user to select action
- Shut down (default, an orderly shutdown is performed)
- Stand by
- Hibernate

Auto On Behavior

Select the desired Ignition Control / Auto On behavior.

The Thor VM1 Auto On options can be configured using the [AutoOn](#) control panel. Please refer to that section for more details on the options below.

For information on the Ignition input signal please see the power cable instructions in the *Thor VM1 Vehicle Mounting Reference Guide*.

Standard

The Thor VM1 is turned on and off manually by the user using the power button on the front of the device.

Ignition Control

The Thor VM1 is turned on automatically when a signal is received via the Ignition Input wire, which is part of the DC Power Cable.

Auto-On

The Thor VM1 automatically powers up when power is provided.

External Connectors

Power the Thor VM1 off before attaching a cable to any port (serial, USB, Audio/CAN, etc.).

Most external connectors for the Thor VM1 are located on the Quick Mount Smart Dock:

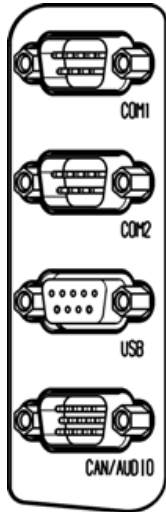

- [COM1](#) connects to a serial bar code scanner, screen blanking cable, serial printer or PC.
- [COM2](#) connects to a serial bar code scanner, screen blanking cable, serial printer or PC.
- [USB](#) accepts a dongle cable with a USB Host port and a USB Client port. USB Client is not used with the Windows Embedded Standard operating system.
- [CANbus/Audio](#) accepts a cable with connections for a mono headset/microphone or a cable with CANbus adapters.

The [power connector](#) is on the dock.

[Antenna connectors](#) are located on the rear of the Thor VM1.

Serial Connector (COM1 and COM2)

The COM1 and COM2 connectors are D-9 male connectors located on the back of the Quick Mount Smart Dock.

Power the Thor VM1 off before attaching a cable to any port (serial, USB, Audio/CAN, etc.).

The serial connectors are industry-standard RS-232, PC/AT standard 9-pin "D" male connector.

Pin 9 is configured to provide +5V for an external bar code scanner.

If a COM port is not being used for a scanner, it can be used for [screen blanking](#) when the vehicle is in motion.

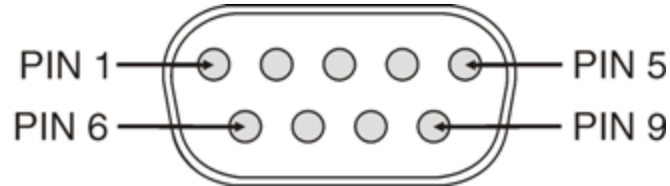

Pinout

Pin	Signal	Description
1	DCD	Data Carrier Detect – Input
2	RXD	Receive Data – Input
3	TXD	Transmit Data – Output
4	DTR	Data Terminal Ready – Output
5	GND	Signal/Power Ground
6	DSR	Data Set Ready – Input
7	RTS	Request to Send – Output
8	CTS	Clear to Send – Input
9	+5VDC	Bar Code Scanner Power - 500mA max
Shell	CGND	Chassis Ground

Screen Blanking

The screen blanking signal can be provided either by a Honeywell Screen Blanking Box or a user supplied switch or relay.

- A [screen blanking box](#) can be used on a vehicle that provides voltage on vehicle motion. Voltage must be within the range specified on the screen blanking box label.
- A [switch or relay](#) can be used when an electrical signal is not available or is outside the acceptable range of the screen blanking box.

A [serial cable](#) must be used to connect the screen blanking device:

- An optional Screen Blanking Box Cable is available from Honeywell, or
- A user supplied serial cable can be used. The cable must provide wires from pins 7 and 8 of the connector. No other wires are used.

	Do not enable Screen Blanking until the cable is properly connected to the specified COM port.
---	--

Serial Cable

Optional Honeywell Screen Blanking Box Cable (part number VM1080CABLE) or customer built cable with the following specifications.

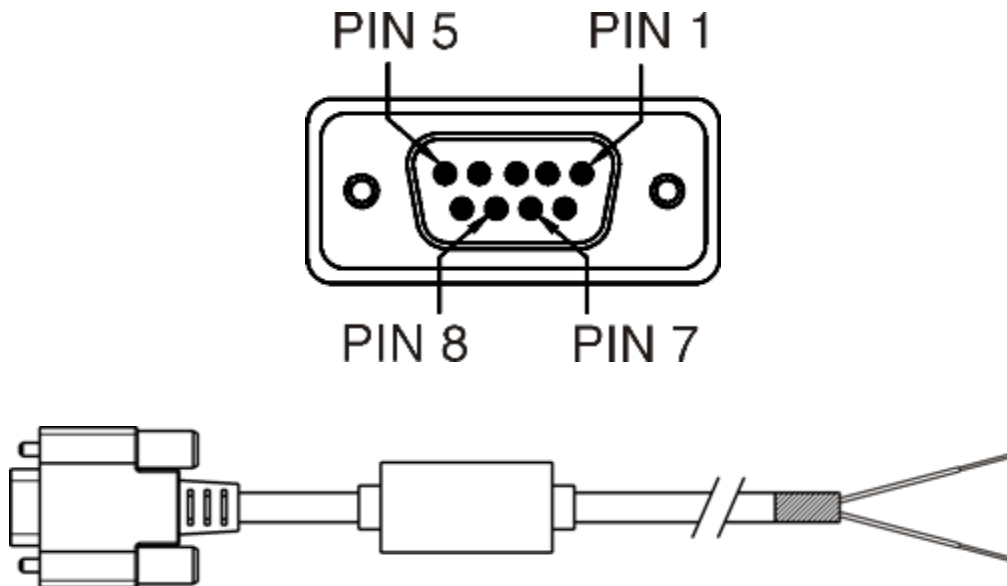

DB9 Female	Function with Screen Blanking Box	Function with Switch	Wire color from Honeywell Cable
1	Not Used	Not Used	
2	Not Used	Not Used	
3	Not Used	Not Used	
4	Not Used	Not Used	
5	Not Used	Not Used	

DB9 Female	Function with Screen Blanking Box	Function with Switch	Wire color from Honeywell Cable
6	Not Used	Not Used	
7 (RTS)	Connected to Screen Blanking Box	Connected to Switch	Black (see note)
8 (CTS)	Connected to Screen Blanking Box	Connected to Switch	Gray (see note)
9	Not Used	Not Used	

Note: Wire colors only apply to optional Honeywell Screen Blanking Box Cable, VM1080CABLE. Wire colors may vary in a user-supplied cable.

Proper COM port settings to support screen blanking are located in [Start > Control Panel > Screen](#).

Screen Blanking Box

Caution 	Please refer to the label on the screen blanking box for allowable input voltage range.
---	---

The Screen Blanking Box is designed to monitor a connection to a vehicle motion sensing circuit. When motion is detected, the Screen Blanking Box opens the connection between the output feeds (which are connected to Pins 7 and 8 of the Thor VM1) and the display on the Thor VM1 is blanked. When motion is no longer detected the Screen Blanking Box provides a connection between the output feeds. After the configured Screen On delay, if any, the Thor VM1 screen is displayed.

Please refer to the wiring instructions, including appropriate cautions and warnings, in the *Thor VM1 Vehicle Mounting Reference Guide*.

Screen Blanking with Switch

In applications where it is impractical to use the screen blanking box due to vehicle voltage or lack of a motion sensing signal, screen blanking can be controlled via a user supplied switch or relay that provides an electrical conductive connection between the wires connected to Pins 7 and 8 of the screen blanking cable on vehicle motion.

Please refer to the wiring instructions, including appropriate cautions and warnings, in the *Thor VM1 Vehicle Mounting Reference Guide*.

USB Connector

The USB connector is a D-9 female connector located on the back of the Quick Mount Smart Dock.

Power the Thor VM1 off before attaching a cable to any port (serial, USB, Audio/CAN, etc.).

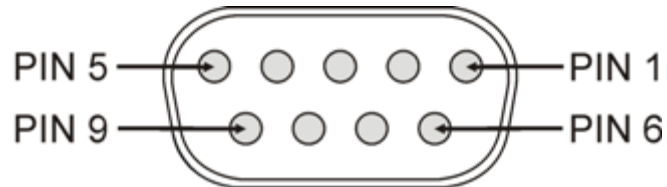

Pin	Signal	Description
1	GND	Common ground
2	USBC_D+	USB client data signal (not used)
3	USBC_D-	USB client data signal (not used)
4	USB_H1_PWR	USB host 1; 5V output power
5	GND	Common ground
6	GND	Common ground
7	USB_H1_D+	USB host 1 data signal
8	USB_H1_D-	USB host 1 data signal
9	USBC_VBUS	USB client 5V detect from attached host (not used)

USB Dongle Cable

USB dongle cables have a Host port and a Client port.

The USB Client port is not used when the Thor VM1 has a Windows Embedded Standard operating system.

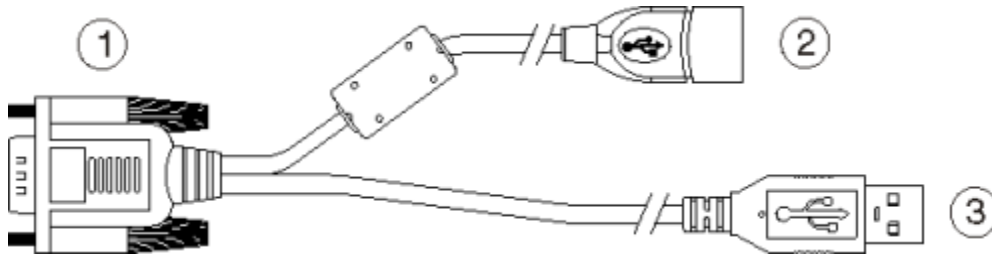

1. D9 Connector
2. USB Host Connector(s)
3. USB Client Connector (not used)

D9 Male Connector

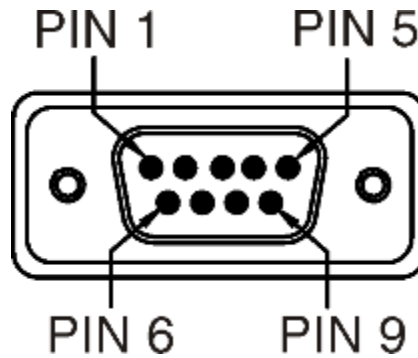

Pin	Signal	Description
1	GND	Common ground
2	USBC_D+	USB client data signal (not used)
3	USBC_D-	USB client data signal (not used)
4	USB_H1_PWR	USB host 5V output power
5	GND	Common ground
6	GND	Common ground
7	USB_H1_D+	USB host 1 data signal
8	USB_H1_D-	USB host 1 data signal
9	USBC_VBUS	USB client 5V detect from attached host (not used)

USB Host Connector



Pin	Signal	Description
1	5V_USB	USB Power, Current Limited
2	USB_H1_D-	USB D-
3	USB_H1_D+	USB D+
4	GND	USB Power Return
Shell	CGND	Chassis Ground

USB Client Connector

The USB Client connector is not supported on the Thor VM1 with the Windows Embedded Standard operating system.

Power Supply Connector

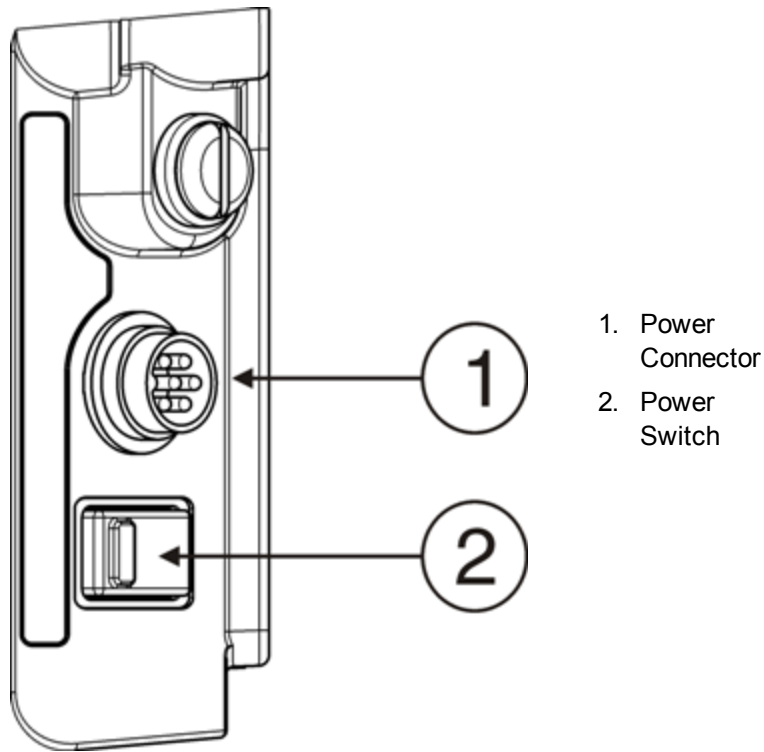

Power is supplied to the Thor VM1 through the power connector. Additionally this assembly provides a connection point for the vehicle's chassis ground to be connected internally to the conductive chassis of the computer.

The Thor VM1 internal power supply can accept DC input voltages in the range of 10 to 60 Volts DC.

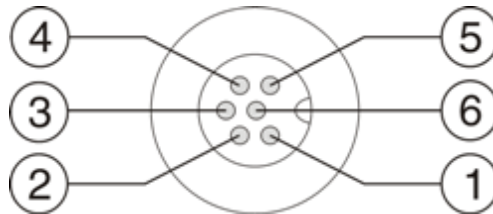

Pin	Signal	Description
1	V In+	10-60V DC input +
2	V In+	10-60V DC input +
3	V In-	input -
4	V In-	input -
5	GND	Chassis ground
6	Ignition	+0V to 60V to start terminal

CANbus / Audio Connector

The CANbus/Audio connector is a D-15 male connector located on the back of the Quick Mount Smart Dock.

The connector supports a headset adapter cable or a CANbus cable. The Thor VM1 does not support connecting audio and CANbus simultaneously.

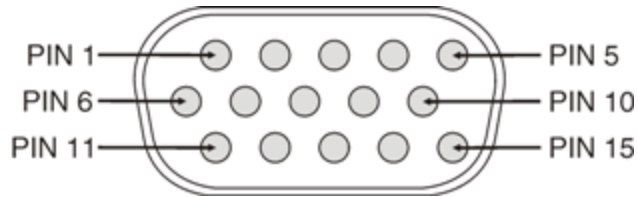

Pin	Signal Name	Description
1	-	CAN reserved
2	CAN_L	CAN_L bus line dominant low
3	CAN_GND	CAN Ground
4	-	CAN reserved
5	GND	Optional ground
6	Audio return	Headset return
7	Audio output	Headset output
8	Mic input	Microphone input
9	Mic return	Microphone return
10	Audio Return	
11	GND	Optional ground
12	CAN_SHLD	
13	CAN_H	CAN_H bus line dominant high
14	-	CAN reserved
15	CAN_V+	Option CAN external Power Supply

Headset Adapter Cable

The headset cable attaches to the CANbus / Audio connector and provides a quick connect connection for a headset.



D15 Female Connector

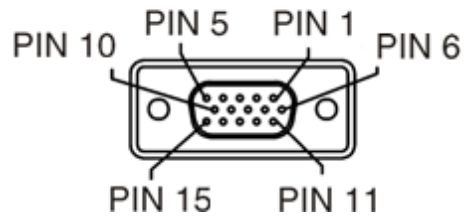

Pin	Signal	Description
1	-	Not used
2	-	Not used
3	-	Not used
4	-	Not used
5	-	Not used
6	Audio return	Headset return
7	Audio output	Headset output
8	Mic input	Microphone input
9	Mic return	Microphone return
10	-	Not used
11	-	Not used
12	-	Not used
13	-	Not used
14	-	Not used
15	-	Not used

Quick Connect Headset Connector

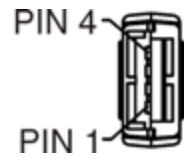

Pin	Signal	Description
1	Mic input	Microphone input
2	Mic return	Microphone return
3	Audio output	Headset output
4	Audio return	Headset return

CANbus Cable

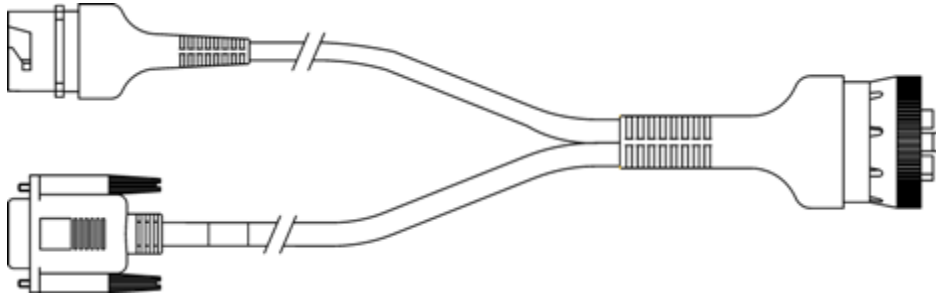

The CANbus interface is a virtual COM4 port. This port can be accessed using standard Windows API calls.

D15 Female Connector

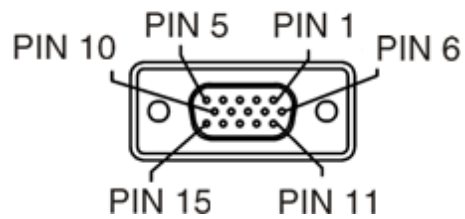

Pin	Signal	Description
1	-	Not used
2	CAN_L	CAN_L bus line dominant low
3	CAN_GND	CAN ground
4	-	CAN reserved
5	GND	Ground
6	-	Not used
7	-	Not used
8	-	Not used
9	-	Not used
10	-	Not used
11	GND	Optional ground
12	CAN_SHLD	
13	CAN_H	CAN_H bus line dominant high
14	-	CAN reserved
15	CAN_V+	CAN external power supply

9-Pin J1939 (Deutsch) Connectors

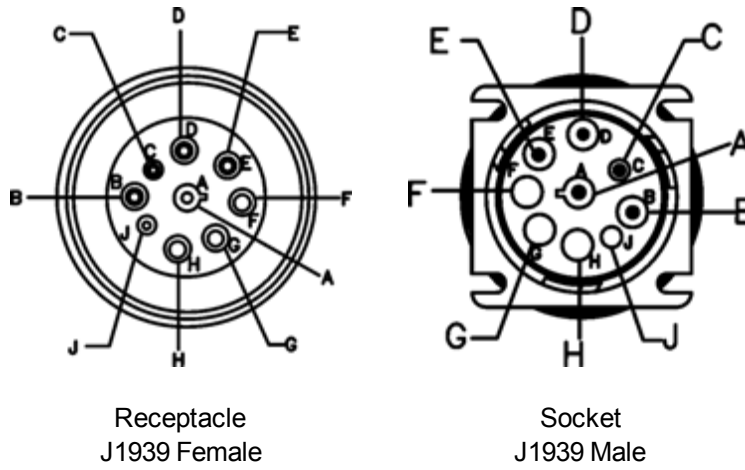

Pin	Signal	Description
A	CAN_GND	CAN Ground
B	CAN_V+	Option CAN external Power Supply
C	CAN_H	CAN_H bus line dominant high
D	CAN_L	CAN_L bus line dominant low
E	CAN_SHLD	
F	-	Not used
G	-	Not used
H	-	Not used
J	-	Not used

Antenna Connections

The Thor VM1 is equipped with an 802.11 radio and can be ordered with internal antennas or external remote mount antennas. When the Thor VM1 is ordered with internal antennas, the external antenna connectors are not used. GPS and WWAN are optional on the Thor VM1 and require external remote mount antennas.

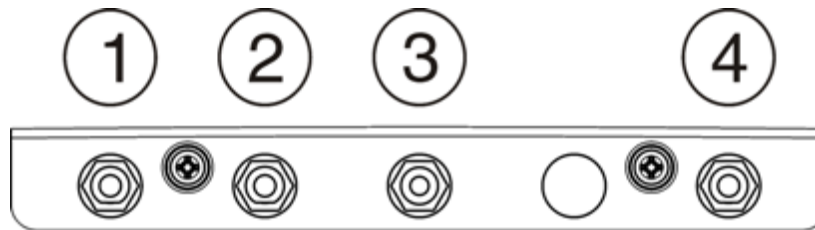

1. WI-FI (MAIN) (Red label) 802.11 Main External Antenna Connector
2. WI-FI (AUX) (Yellow label) 802.11 Auxiliary External Antenna Connector
3. GPS (Green label) GPS Antenna Connector
4. MOBILE NET (Blue label) WWAN Antenna Connector

Antenna Connector

When the Thor VM1 is ordered with the internal antenna option, the 802.11 antenna connectors on the back are not connected to the 802.11 radio. Instead the internal antenna is connected to the 802.11 radio.



Remove the rubber cap, if present, from the antenna connector before connecting an external antenna.

Internal WiFi Antenna

If the internal WiFi antenna option is ordered, an antenna is mounted inside the Thor VM1. The internal antenna is not user accessible.

Vehicle Remote Antenna

The external antennas can be remotely mounted on the vehicle. See the *Thor VM1 Vehicle Mounting Reference Guide* for instruction. External antenna kits are available for the 802.11 WiFi radio, GPS and WWAN.

Keyboard Options

The 2nd, ALT, CTRL and Shift keys are sticky keys. The [keyboard LED behavior](#) identifies the active sticky modifier mode state of the keyboard.

64-Key QWERTY Keyboard



The Thor VM1 has a QWERTY keyboard, available with a standard overlay, an IBM 3270 overlay or an IBM 5250 overlay.

- Because the keyboard only has 64 keys, all functions are not visible (or printed on the keyboard). Therefore the Thor VM1 keyboard supports what is called hidden keys – keys that are accessible but not visible on the keyboard.
- The keypad does not have a NumLock indicator or key. NumLock is always On.

The Thor VM1 keyboard is backlit.

- By default, the keyboard backlight follows the display backlight. When the display backlight is on, the keyboard backlight is on.
- If the display backlight brightness is increased (or decreased) the keyboard backlight brightness is increased (or decreased).
- The keyboard backlight and the display share the same timer, which is configured in [Start > Control Panel > Power](#).

IBM 3270 Overlay



IBM 5250 Overlay



Keyboard LEDs

Shift LEDs

Note: TheThor VM1 has two Shift keys with an LED beside each key.

The Shift LEDs indicate the state of the keyboard Shift mode. If Shift is enabled the Shift LEDs beside both Shift keys (64-key only) blink green. When CapsLock is enabled, both Shift LEDs are lit solid green. When Shift and CapsLock are both off, the LEDs are off.

Press either Shift key to toggle Shift On and Off. press 2nd plus either Shift key to toggle CapsLock On or Off.

Secondary Keys LED

The Thor VM1 keyboard is equipped with several secondary keys. These keys are identified by the superscript text found on the keyboard keys.

The secondary keys are accessible by using two (2) keystrokes: the 2nd key followed by the superscript key.

Once the 2nd state is enabled (by pressing the 2nd key) the Secondary Mode LED is illuminated and the 2nd state is enabled until another key is pressed.

The 2nd key is toggled on with a 2nd key press and then immediately off with another 2nd key press.

For example:

Press 2nd and F1 to generate F11.

Ctrl and Alt Key LEDs

When the modifier keys (Ctrl or Alt) are active, the LED located next to the key is illuminated. The modifier key remains active until:

- The modifier key is pressed again, or
- A non-modifier key is pressed.

USB Keyboard / Mouse

A standard USB keyboard or mouse can be attached to the Thor VM1 using the appropriate dongle cable.

The dongle cable attaches to the Thor VM1 and provides a USB connector. Please refer to documentation provided with the USB keyboard or mouse for more information on their operation.

LED Functions

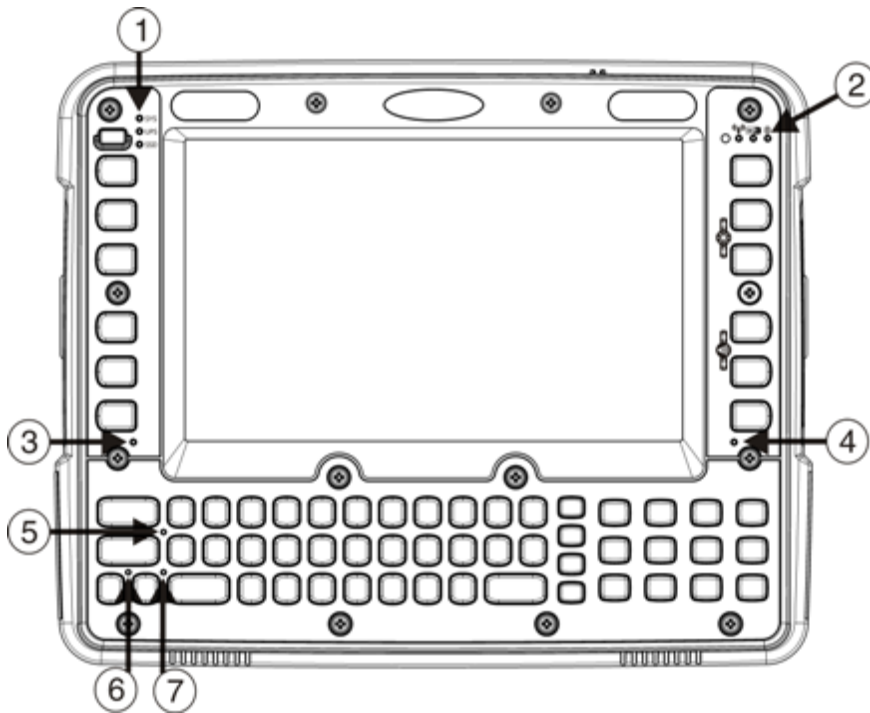

1. System LEDs
2. Connection LEDs
3. 2nd LED
4. Shift/CapsLock LED
5. Shift/CapsLock LED
6. Ctrl LED
7. Alt LED

System LEDs

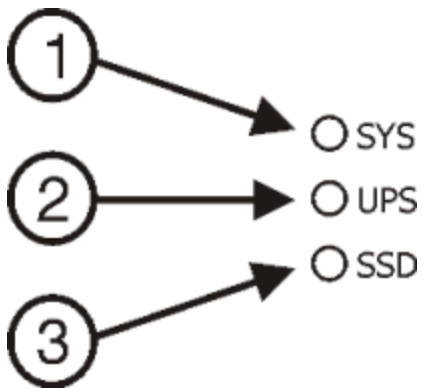

1. SYS (System Status) LED
2. UPS (Uninterruptible Power Supply) LED
3. SSD (Solid State Drive) LED

SYS (System Status) LED

LED Behavior	System State
Solid Green	<ul style="list-style-type: none">• On• On but Display Off
Green blinking very slowly External power present (1/2 sec. on, 4 1/2 sec. off)	<ul style="list-style-type: none">• Hibernate,• Standby
Off External power not present	<ul style="list-style-type: none">• Off• Hibernate,• Standby
Green blinking slowly External power present (1/2 sec. on, 1 1/2 sec. off)	CPU temperature less than -20°C, Heater warming CPU for 30 seconds
Green blinking slowly External power not present (1/2 sec. on, 1 1/2 sec. off)	CPU temperature less than -20°C, Need to move unit to warmer environment

UPS Status LED

The behavior of the UPS LED depends if external power is connected or not.

External Power Present

LED Behavior	Status
Off	<ul style="list-style-type: none">• No UPS charging,• UPS charged
Solid Green	UPS charging
Solid Amber	<ul style="list-style-type: none">• Any charging fault,• Out of charging temperature range,• No UPS present,• Charge timeout

External Power Not Present

LED Behavior	Status
Off	<ul style="list-style-type: none">• Unit off,• UPS not present
Solid Amber	UPS supplying power and discharging
Solid Red	Approximately 2 minutes runtime until shutdown

SSD (Solid State Drive) LED

LED Behavior	Status
Flashing Green	SSD read or write activity.
Off	No SSD read or write activity.

Connection LEDs

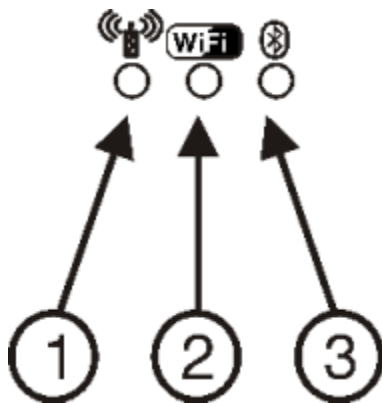

1. WWAN LED
2. WiFi LED
3. Bluetooth LED

WWAN LED

LED Behavior	Status
Solid Green	Indicates a WWAN connection to a network.
Off	Indicates no WWAN connection.

WiFi LED

LED Behavior	Status
Solid Green	Indicates a connection with an IP address to an Access Point
Off	Indicates no connection to an Access Point.

Bluetooth LED

LED Behavior	Status
Blue Blinking Slowly	Bluetooth is paired but not connected to a device.
Blue Blinking Medium	Bluetooth is paired and connected to a device.
Blue Blinking Fast	Bluetooth is discovering Bluetooth devices.
Off	Bluetooth hardware has been turned off.

The Bluetooth LED blinks once every 6 seconds when the Bluetooth client is paired but not connected. It blinks once for a very short time every 2 seconds when paired and connected. It blinks every second when in discovery. The LED is off when the Bluetooth client is off.

Keyboard LEDs

The keyboard LEDs are located near the specified key.

2nd LED

LED Behavior	Status
Solid Green	<ul style="list-style-type: none">Indicates the 2nd modifier key is active. 2nd mode is invoked for the next keypress only.Pressing the 2nd key a second time exits this modifier mode and turns off the LED.
Off	2nd mode is not invoked.

Shift LEDs

There is one LED next to each **Shift** key. Both LEDs indicate the status of Shift mode and Caps Lock mode.

LED Behavior	Status
Blinking Green	<ul style="list-style-type: none">Indicates the keypad is in Shift mode. Shift mode is invoked for one keypress.Pressing the Shift key places the system in Shift mode.To exit Shift mode, press the Shift key again.
Solid Green	<ul style="list-style-type: none">When solid Green, indicates the keypad is in Caps Lock mode. Caps Lock mode is invoked until canceled.Pressing the 2nd key followed by the Shift key places the system in Caps Lock mode.To exit Caps Lock mode, press 2nd + Shift again.
Off	Neither Shift or Caps Lock mode is invoked.

Ctrl LED

LED Behavior	Status
Solid Green	<ul style="list-style-type: none">Indicates the Ctrl modifier key is active. Ctrl mode is invoked for the next keypress only.Pressing the Ctrl key a second time exits this modifier mode and turns off the LED.
Off	Ctrl mode is not invoked.

Alt LED

LED Behavior	Status
Solid Green	<ul style="list-style-type: none">• Indicates the Alt modifier key is active. Alt mode is invoked for the next keypress only.• Pressing the Alt key a second time exits this modifier mode and turns off the LED.
Off	Alt mode is not invoked.

Display

The display is a thin-film transistor display capable of supporting WVGA graphics modes. Display size is 800 x 480 pixels. The display covering is designed to resist stains. The touch screen allows signature capture and touch input. The display supports screen blanking to eliminate driver distraction when the vehicle is in motion.

Touch Screen

The touch screen is a Resistive Panel with a scratch resistant finish that can detect touches by a stylus, and translate them into computer commands. In effect, it simulates a computer mouse. Only Delrin or plastic styluses should be used. A right mouse click is simulated by touching and holding the screen for the appropriate time interval.

When a dialog box is too large for the display, tap and drag the dialog box up or down or from side to side to view the remainder of the dialog box.

Always use the point of the stylus for tapping or making strokes on the display. Never use an actual pen, pencil, sharp or abrasive object to write on the touch screen.

An extra or replacement stylus may be ordered.

A replaceable touch screen protective film is available when the Thor VM1 is used in an abrasive environment. Contact [Technical Assistance](#) for availability.

Touch Screen Defroster

Extended temperature versions of the Thor VM1 contain a touch screen defroster. The touch screen defroster can be disabled when not needed ([Start > Control Panel > Screen](#)). The defroster trip point is configurable. The defroster is always disabled when the device is operating from UPS battery power.

Screen Blanking

Screen blanking (blackout) can be enabled when the vehicle is in motion. A [serial cable](#) must be attached to the Thor VM1 and the Thor VM1 must be configured to enable screen blanking ([Start > Control Panel > Screen](#)). Once screen blanking is enabled, the display is blanked out any time when the cable sends the signal the vehicle is in motion. If the cable is removed, screen blanking is disabled and the display remains on.

Display Backlight Control

The display brightness on a Thor VM1 equipped with an outdoor display can be configured to automatically adjust depending on the ambient light level ([Start > Settings > Control Panel > Screen](#)).

Note: When automatic brightness control is enabled, the manual display brightness controls described below have no effect.

The display brightness can be adjusted manually, via the keypad:

- Use the **2nd + F7** keypress to increase backlight brightness and the **2nd + F8** keypress to decrease backlight brightness.

Disconnect UPS Battery

Equipment Required- User Supplied:

- Torquing tool capable of measuring inch pounds
- #2 Philips screwdriver bit

Caution 	The UPS battery must be disconnected before shipping the Thor VM1, replacing the UPS battery or replacing the front panel .
--	---

1. For convenience, the Thor VM1 can be removed from the Quick Mount Vehicle Dock, though it is not necessary.
2. If the Thor VM1 remains in the Dock, disconnect the power cable from the Dock.
3. Shutdown the Thor VM1.
4. Place the Thor VM1 face down on a stable surface.
5. Using a #2 Philips bit loosen the M3 screws and then remove the tethered access panel with the SIM label. This panel is on the right hand side when the Thor VM1 is face down with the top away from the user.

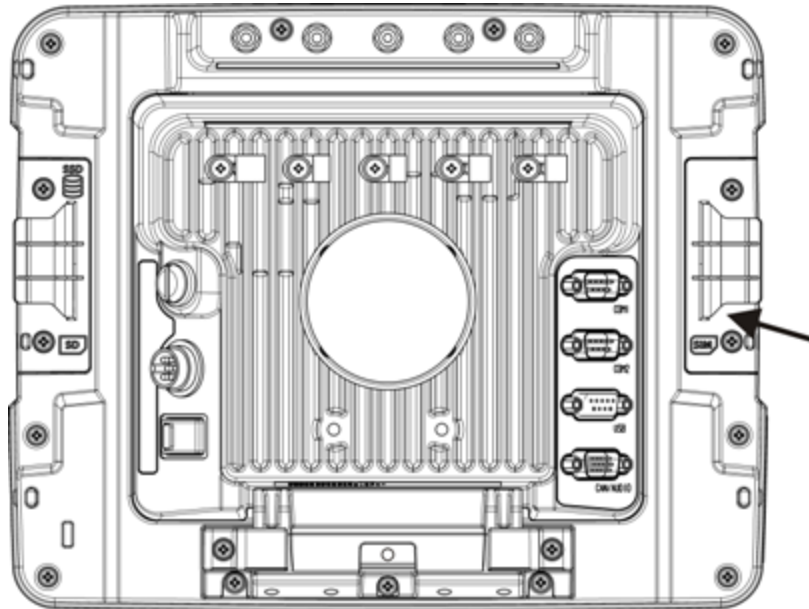

6. Locate the small push button located just below the SIM card installation slot.

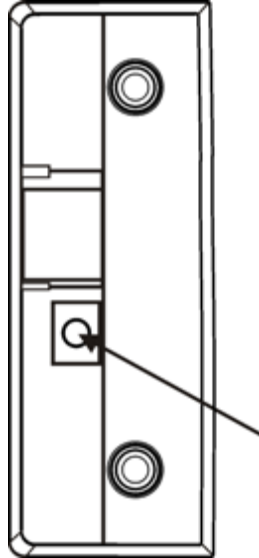

7. Press the push button to disconnect the UPS. The UPS battery maintains its charge but is disconnected from the power circuitry of the Thor VM1.
8. Reattach the access panel, torquing the M3 screws to 4-5 inch pounds using a #2 Philips bit.
9. When the Thor VM1 is attached to external power, the UPS battery is automatically reconnected.

Install SD Card

Equipment Required - User Supplied:

- Torquing tool capable of measuring inch pounds
 - #2 Philips screwdriver bit
 - SD card - The following commercially available SD cards are recommended:
 - Transcend[®] 2GB Industrial SD card (80X Speed) - **TS2GSD80I**
 - ATP 4GB Industrial Grade SDHC card - **AF4GSDI**
1. For convenience, the Thor VM1 can be removed from the Quick Mount Vehicle Dock, though it is not necessary.
 2. Shutdown the Thor VM1 from the Windows menu.
 3. Place the Thor VM1 face down on a stable surface.
 4. Using a Phillips screwdriver (not supplied) loosen the screws and then remove the tethered access panel with the SSD and SD label. This panel is on the left hand side when the Thor VM1 is face down with the top away from the user.

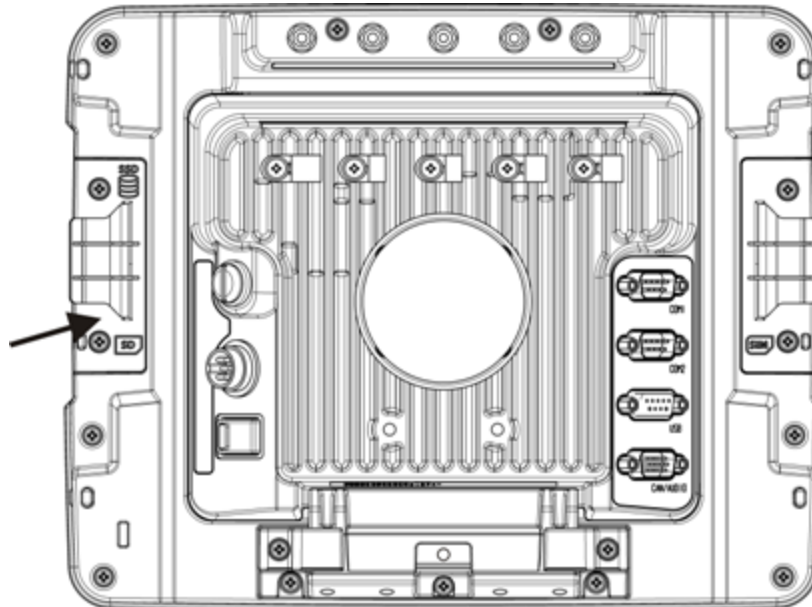

5. Locate the SD card installation slot.

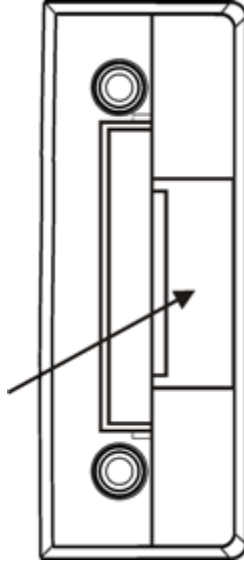

6. Slide the SD card into the slot. The label side (front) of the SD card faces toward the back of the Thor VM1.
7. Reattach the access panel, torquing the screws to 4-5 inch pounds.
8. If removed, reinstall the Thor VM1 in the Dock.
9. Restart the Thor VM1
10. When using Windows explorer to view **My Computer**, the SD card is identified as a **Removable Disk**, usually Drive D:

Install SIM Card

Equipment Required - User Supplied:

- Torquing tool capable of measuring inch pounds
 - #2 Phillips screwdriver bit
1. For convenience, the Thor VM1 can be removed from the Quick Mount Vehicle Dock, though it is not necessary.
 2. Shutdown the Thor VM1 from the Windows menu.
 3. Place the Thor VM1 face down on a stable surface.
 4. Using a Phillips screwdriver (not supplied) loosen the screws and then remove the tethered access panel with the SIM label. This panel is on the right hand side when the Thor VM1 is face down with the top away from the user.

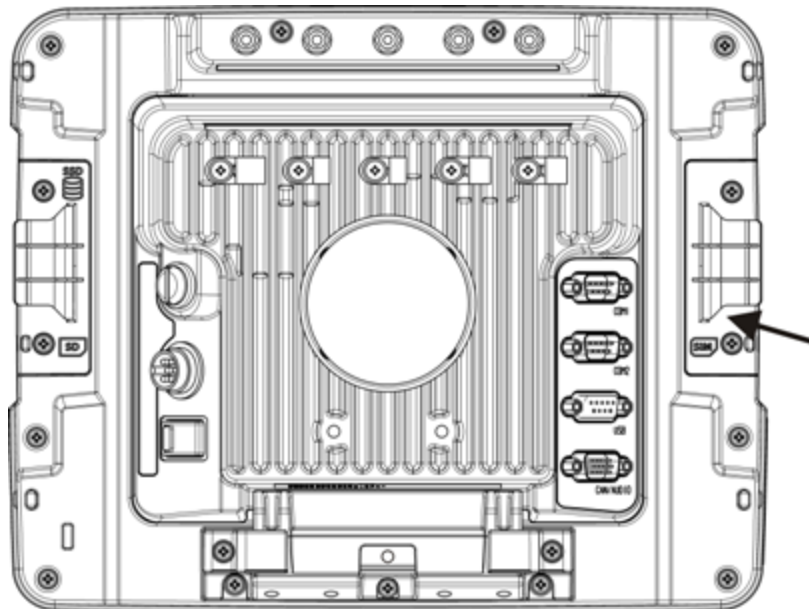

5. Locate the SIM card installation slot.

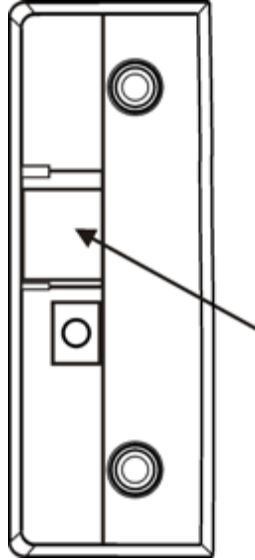

6. Slide the SIM card into the slot.
7. Reattach the access panel, torquing the screws to 4-5 inch pounds.
8. If removed, reinstall the Thor VM1 in the Dock.
9. Restart the Thor VM1

Field Replaceable Front Panel

Equipment Required - User Supplied:

- Torquing tool capable of measuring inch pounds
- #2 Philips screwdriver bit

Caution



Before replacing the Thor VM1 front panel, the internal [UPS battery must be disconnected](#).

The front panel of the Thor VM1 is field replaceable. The front panel assembly contains the keyboard, touch screen and optional defroster. Should any of these components fail, the front panel assembly can easily be replaced to reduce downtime. The replacement front panel is available in several configurations:

- 64-key ANSI keyboard with standard touch screen or cold storage touch screen
- 64-key 3270 keyboard with standard touch screen or cold storage touch screen
- 64-key 5250 keyboard with standard touch screen or cold storage touch screen

Replace Front Panel

1. Place the Thor VM1 on a clean, well-lit surface before performing the front panel replacement.
2. Shutdown the Thor VM1 from the Windows menu.
3. Remove the Thor VM1 from the Quick Mount Smart Dock.
4. [Disconnect the UPS](#).
5. Loosen the fourteen (14) captive M3 screws holding the front panel. Use a #2 Philips bit.

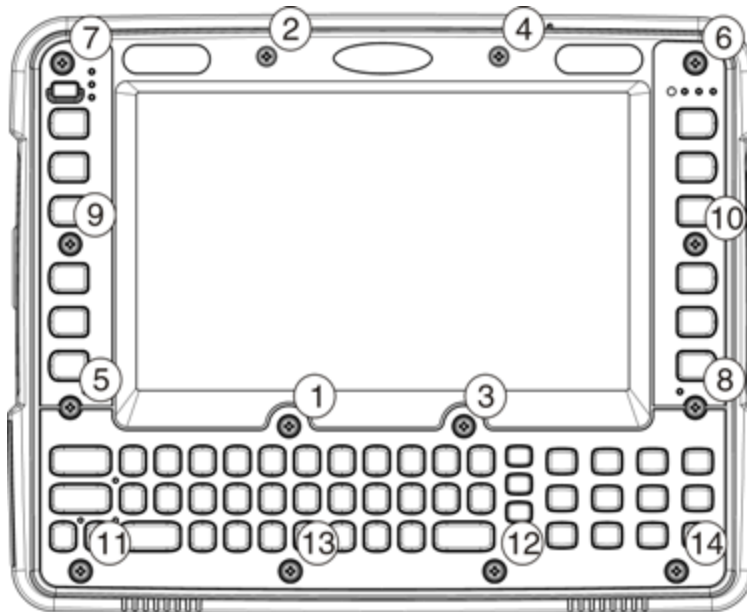

-
- Carefully lift the front panel away from the device.

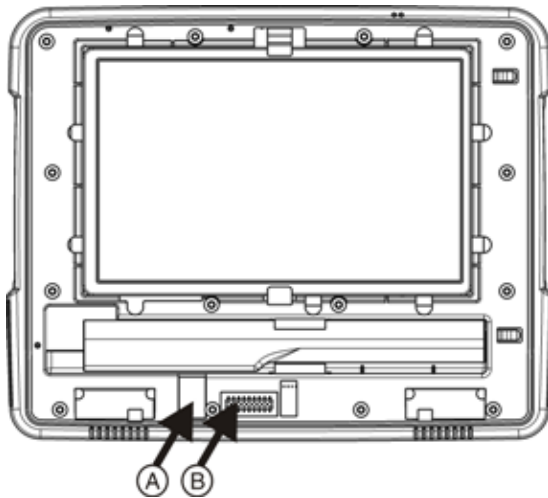

- A. Slot on Thor VM1 body
- B. Wiring connector on Thor VM1 body

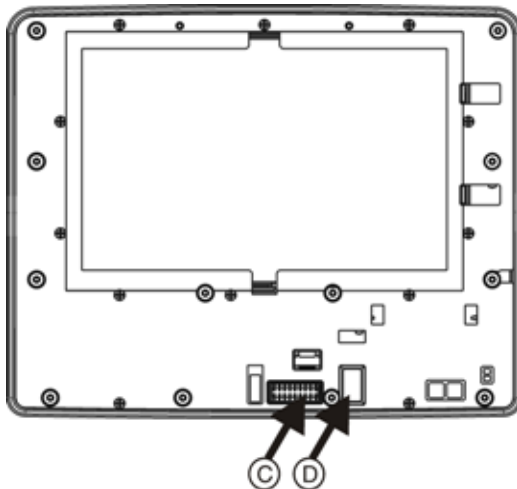

- C. Wiring connector on front panel
- D. Tab on front panel

- Position the replacement front panel so the tab on the back of the front (D in figure above) panel lines up with the slot (A in figure above) on the Thor VM1. Be sure the two wiring connectors (B and C in figures above) are also aligned.
- Gently press the front panel into place.
- Tighten the fourteen (14) captive M3 screws. In the order shown in the top figure above, use a #2 Philips bit and torque the screws to 6-7 inch pounds.
- Reinstall the Thor VM1 in the Quick Mount Smart Dock.
- When the Thor VM1 is placed in the powered dock, the UPS battery automatically reconnects.
- Restart the Thor VM1.
- When restarted, the Thor VM1 automatically recognizes the keyboard type.

Field Replaceable UPS Battery

Requirements - User Supplied:

- Torquing tool capable of measuring inch pounds
- #2 Philips screwdriver bit

Caution



Before replacing the Thor VM1 UPS battery, the internal [UPS battery must be disconnected](#).

The UPS battery in the Thor VM1 is field replaceable. Should the UPS battery fail, it can easily be replaced to minimize downtime.

Replace UPS Battery

1. Place the Thor VM1 on a clean, well-lit surface before performing the UPS battery replacement.
2. Shutdown the Thor VM1 from the Windows menu.
3. Remove the Thor VM1 from the Quick Mount Smart Dock.
4. [Disconnect the UPS](#).
5. Loosen the fourteen (14) captive M3 screws holding the front panel. Use a #2 Philips bit.

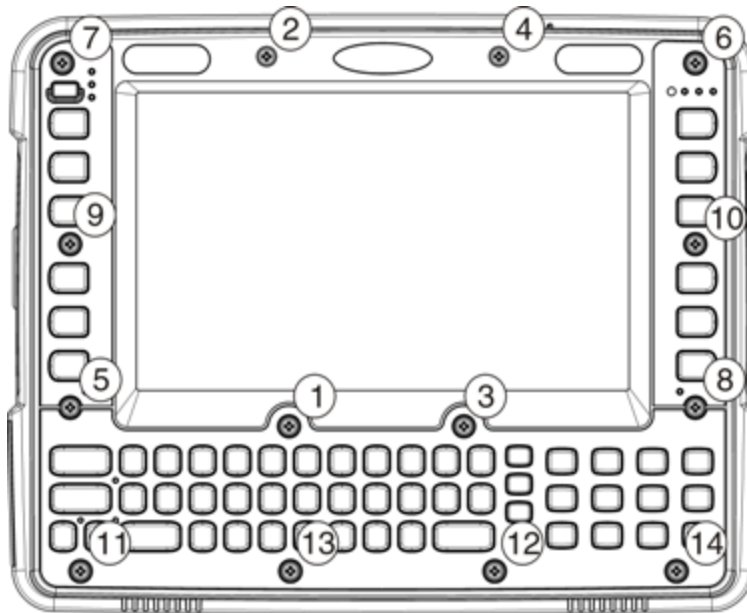

- Carefully lift the front panel away from the device.

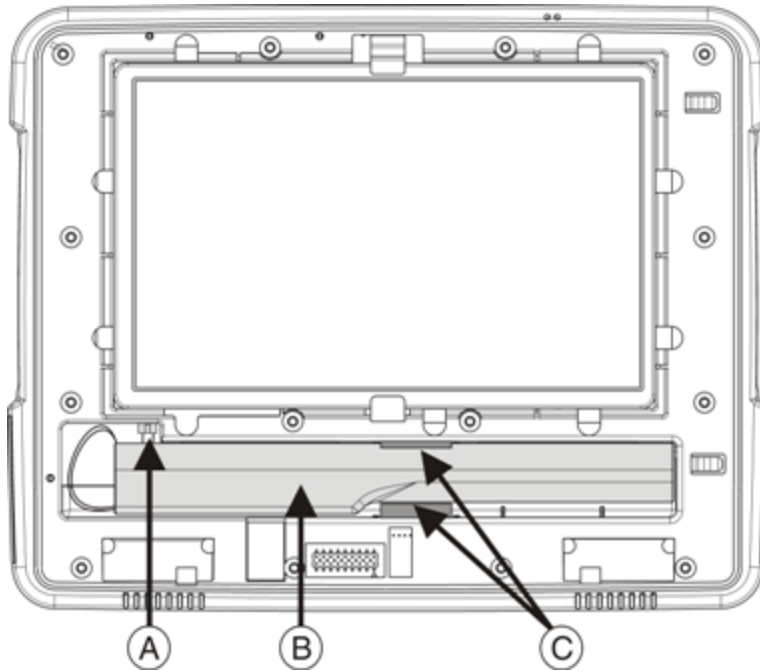

- A. Wiring Connector
- B. UPS Battery
- C. Foam Pads

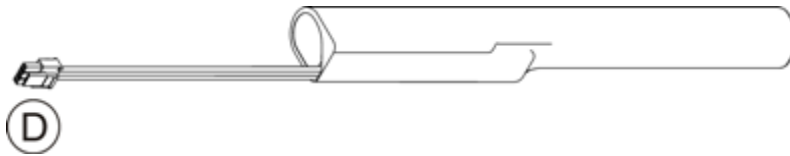

- D. Release Tab on Wiring Connector

- Note the orientation of the UPS battery. Lift the UPS battery out of the battery well and place it outside the well. Do not pull on the wires attaching the battery to the Thor VM1 while lifting the battery.
- Locate the retaining tab on the wiring connector for the UPS battery. Press on the tab and gently disconnect the UPS battery wiring from the Thor VM1.
- Remove the old battery and set it aside.
- Inspect the battery well to verify the two foam pads are still in place.
- Align the wiring connector on the new UPS battery with the connector on the Thor VM1. Gently press the connector into place until the retaining tab snaps into place.
- Place the UPS battery into the well. Note the orientation of the battery in the illustration below. The flat surface of the battery points toward the bottom of the Thor VM1. Make sure all wires are inside the battery well so they are not pinched when the front panel is reinstalled..

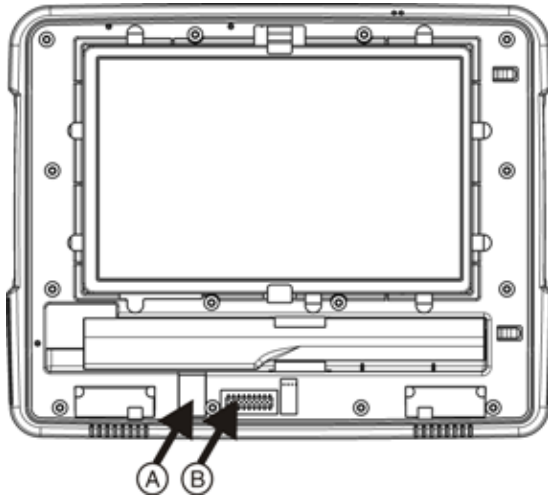

- A. Slot on Thor VM1 body
- B. Wiring connector on Thor VM1 body

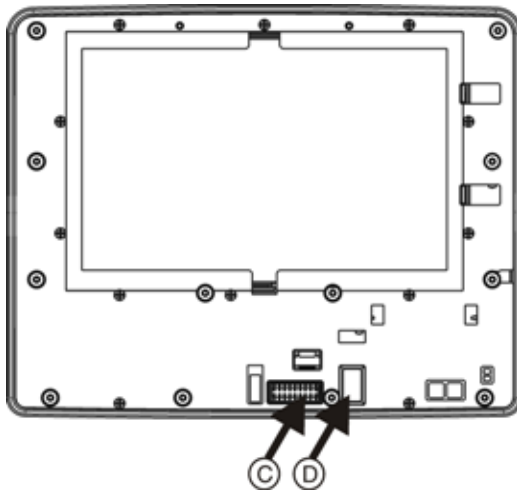

- C. Wiring connector on front panel
- D. Tab on front panel

12. Position the front panel so the tab on the back of the front (D in figure above) panel lines up with the slot (A in figure above) on the Thor VM1. Be sure the two wiring connectors (B and C in figures above) are also aligned.
13. Gently press the front panel into place.
14. Tighten the fourteen (14) captive M3 screws. In the order shown in the top figure above, use a #2 Philips bit and torque the screws to 6-7 inch pounds.
15. Reinstall the Thor VM1 in the Quick Mount Smart Dock.
16. When the Thor VM1 is placed in the powered dock, the UPS battery automatically reconnects. The UPS battery automatically begins charging from the powered dock.
17. Restart the Thor VM1.

Chapter 3: Software

Microsoft Windows Setup and Configuration

After the system files are processed, Microsoft Windows begins to load. Windows maintains a System Registry and INI files. Standard Windows configuration options apply to the Thor VM1. Configuration options are located in the System Tray or the Control Panel:

- The System Tray contains icons for adjusting the time, date or volume level.
- The Control Panel contains icons for many other configuration options, such as Power Management, Regional and Language Options, etc.
- The Control Panel icons are also used to add, delete or modify software installed on the Thor VM1.

Drive C Folder Structure

Microsoft Windows is installed in the \Windows folder. In addition, Microsoft Windows creates other folders and several subfolders. For more information on the folder structure, please refer to commercially available Microsoft Windows OS reference guides.

Software Loaded on Drive C

The software loaded on the Thor VM1 computer consists of:

- BIOS
- Microsoft operating system (Windows Embedded Standard 2009)
- device drivers
- radio software
- touch screen software

The software installed on the Thor VM1 is summarized below.

Note: Due to the complex folder structure and System Registry under Microsoft Windows, software should not be removed manually. Instead use the Add or Remove Programs icon in the Windows Control Panel.

Microsoft Windows

Microsoft Windows is installed in the \Windows subfolder, which is the Windows default. In addition, Windows places files in other folders and subfolders during installation. For more information, please refer to commercially available Microsoft Windows OS user guides.

Device Drivers

Device drivers are installed for all installed hardware options, such as the display, touch screen, radios, etc. For more information on Microsoft Windows device drivers, please refer to commercially available Windows OS reference guides.

Radio Software

The Thor VM1 is delivered with the radio software installed. Because the Thor VM1 uses a Microsoft Windows operating system, the radio installation includes Windows device drivers.

Touch Screen Software

PenMount Universal software is installed for calibrating the touch screen. Please see [Touch Screen Calibration](#) for more information.

Programs Loaded on Drive C

LXE RFTerm (Optional)

Start > All Programs > LXE RFTerm

Terminal emulation software. The application can also be accessed by double-clicking the RFTerm desktop icon.

Summit Client Utility

Start > Control Panel > Wi-Fi

Manage wireless clients installed in the Thor VM1.

Freefloat Link*One Wedge (Optional)

Link*One bar code decoder configuration software is available on the Thor VM1. Click [here](#) for the Freefloat website.

Freefloat Access*One TE (Optional)

Access*One terminal emulation software is available on the Thor VM1. Click [here](#) for the Freefloat website.

Control Panel

Most control panel applets on the Thor VM1 are standard Microsoft Windows items.

The control panels and other functions listed below may differ from a standard Microsoft Windows equipped PC or laptop.

About

Start > Control Panel > About (Classic view)

The Software, Hardware and Versions tabs displays hardware and software version information as stored in the registry.

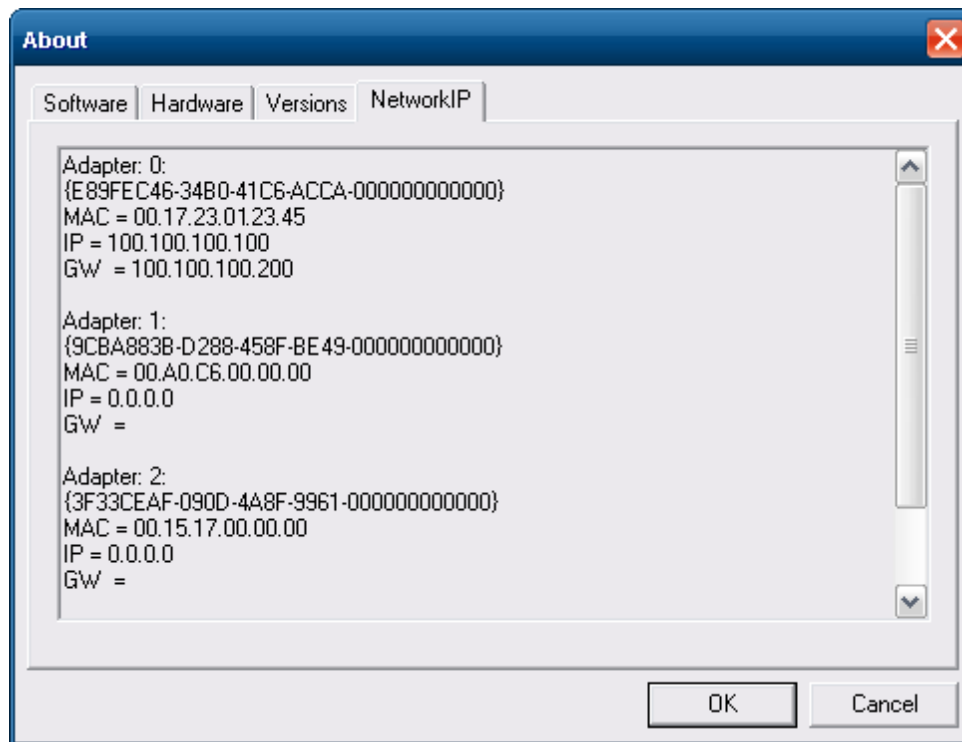

The NetworkIP tab displays information on network connections, such as IP and MAC addresses.

AutoOn

Start > Control Panel > AutoOn (Classic view)

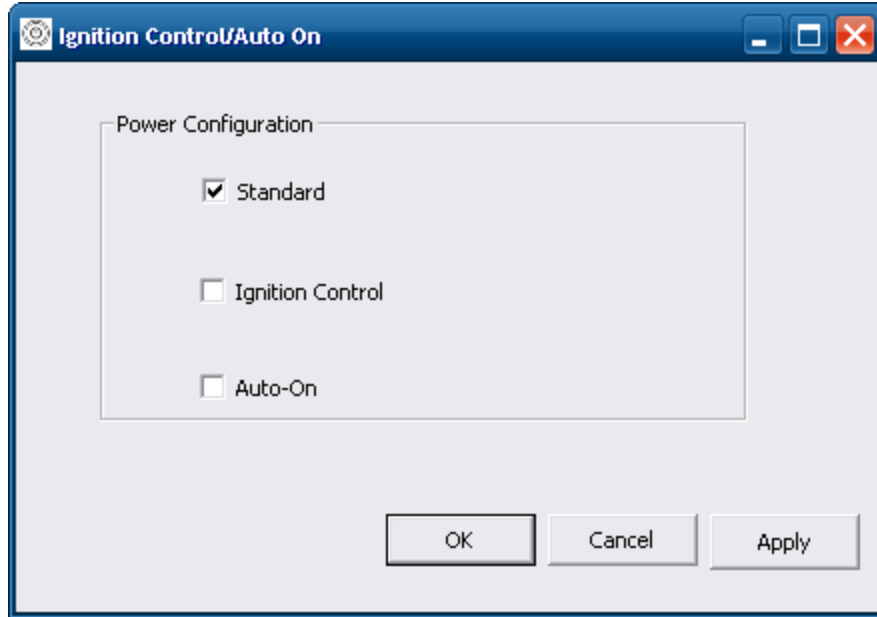

Select the desired Ignition Control / Auto On behavior.

Standard

The Thor VM1 is turned on and off manually by the user using the power button on the front of the device.

- The power switch on the Quick Mount Smart Dock must be On and the Thor VM1 connected to external power.
- In the absence of external power the Thor VM1 can operate from a sufficiently charged UPS battery.
- The Ignition Input wire, which is part of the DC Power Cable, is left disconnected.

When the Thor VM1 is on, the behavior of the power button press is configurable using the [Power Options](#) control panel.

Ignition Control

The Thor VM1 is turned on automatically when a signal is received via the Ignition Input wire, which is part of the DC Power Cable.

- The power switch on the Quick Mount Smart Dock must be On.
- The Ignition Input wire is connected to an appropriate source that provides a signal when vehicle ignition is turned on. Please see the Thor VM1 WES Vehicle Mounting Reference Guide for cautions and wiring instructions.

When the vehicle ignition is turned off, this is treated the same as a power button press. The behavior of the power button press is configurable using the [Power Options](#) control panel.

Auto-On

The Thor VM1 automatically powers up when power is provided. This could be from switched vehicle power, the power switch on the Quick Mount Smart Dock being placed in the On position or external AC power being applied.

- The power switch on the Quick Mount Smart Dock must be On for external power to control the device.
- The Ignition Input wire, which is part of the DC Power Cable, is left disconnected.

No action occurs when the power source is disconnected.

Bluetooth

Start > Control Panel > Bluetooth

Note: Contact [Technical Assistance](#) for upgrade availability if your Bluetooth control panel is not the same as the control panel presented in this section.

Discover and manage pairing with nearby Bluetooth devices.

Factory Default Settings

Discovered Devices	None
Settings	
Turn Off Bluetooth	Disabled
Computer is connectable	Enabled
Computer is discoverable	Disabled
Prompt if devices request to pair	Enabled
Continuous search	Disabled
Filtered Mode	Enabled
Printer Port on COM7:	Disabled (unchecked) by default in both Filtered and Non Filtered Modes. The option is dimmed in Non Filtered Mode.
Logging	Disabled
Computer Friendly Name	System Computer Description
Reconnect	
Report when connection lost	Enabled
Report when reconnected	Disabled
Report failure to reconnect	Enabled
Clear Pairing Table on Boot	Disabled
Auto Reconnect on Boot	Enabled
Auto Reconnect	Enabled

Bluetooth taskbar Icon state and Bluetooth device Icon states change as Bluetooth devices are discovered, paired, connected and disconnected. There may be audible or visual signals as paired devices re-connect with the Thor VM1.

- The default Bluetooth setting is On.
- The Thor VM1 cannot be discovered by other Bluetooth devices when the **Computer is discoverable** option is disabled (unchecked) on the Settings panel.
- Other Bluetooth devices cannot be discovered if they have been set up to be Non-Discoverable or Invisible.
- When **Filtered Mode** is enabled, the Thor VM1 can pair with one Bluetooth scanner and one Bluetooth printer.
- When **Filtered Mode** is disabled, the Thor VM1 can pair with up to four Bluetooth devices.
- It is not necessary to disconnect a paired scanner and printer before a different scanner or printer is paired with the Thor VM1.
- The target Bluetooth device should be as close as possible (up to 32.8 ft (10 meters) Line of Sight) to the Thor VM1 during the pairing process.

Assumption: The System Administrator has Discovered and Paired targeted Bluetooth devices for the Thor VM1. The Thor VM1 operating system has been upgraded to the revision level required for Bluetooth client operation. An application (or API) is available that will accept data from serial Bluetooth devices.

Bluetooth Devices

The Bluetooth Devices tab displays any device previously discovered and paired with the Thor VM1.

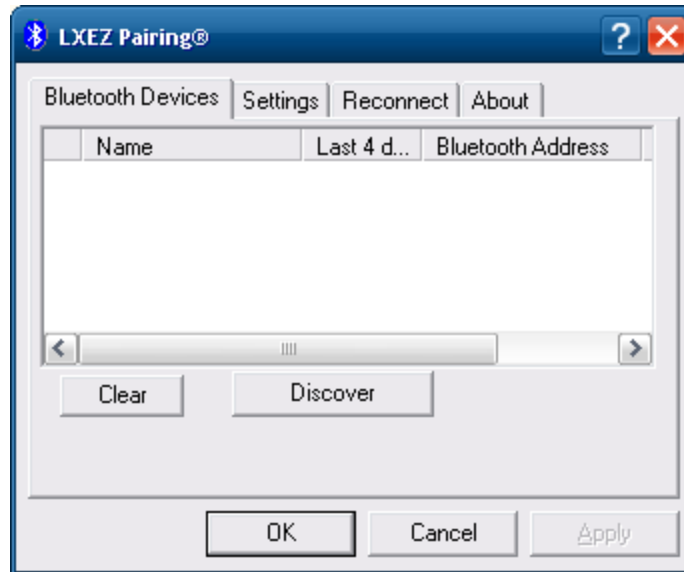

Discover

Tap the Discover button to locate all discoverable Bluetooth devices in the vicinity. The Discovery process also queries for the unique identifier of each device discovered.

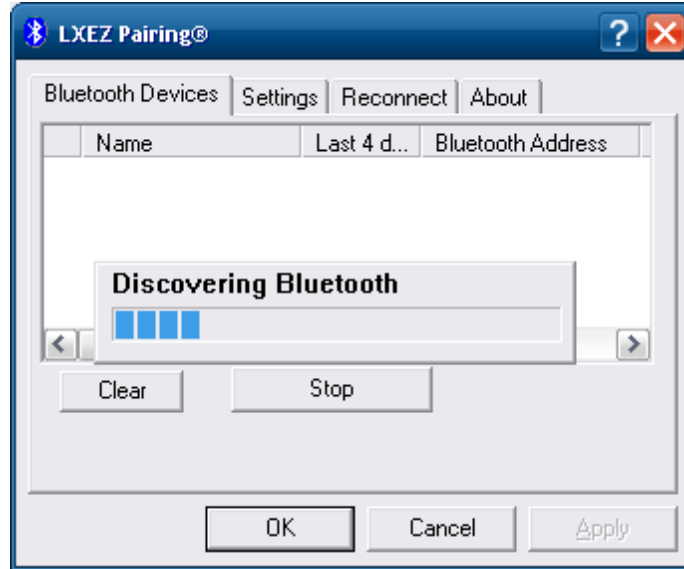

Stop Button

Tap Stop at any time to end the Discover and Query for Unique Identifier functions.

Note: When an active paired device enters Suspend Mode, is turned Off or leaves the Thor VM1 Bluetooth scanning range, the Bluetooth connection between the paired device and the Thor VM1 is lost. There may be audible or visual signals as paired devices disconnect from the Thor VM1.

Bluetooth Device List

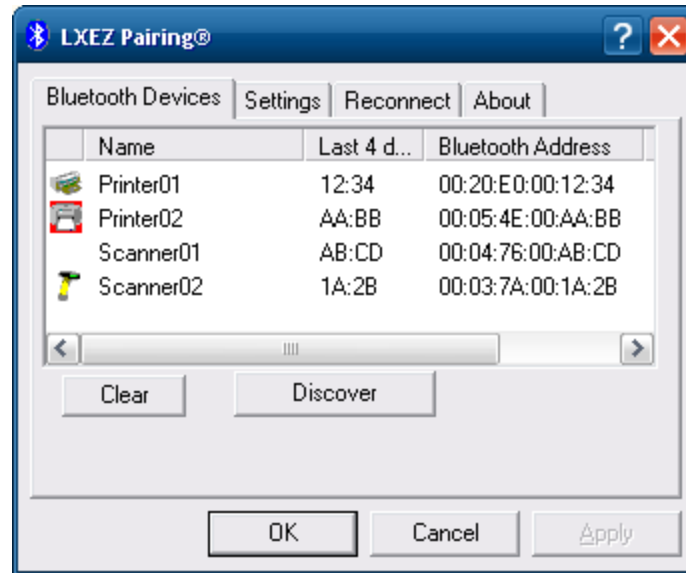

The discovered paired devices may or may not be identified with an icon. Discovered devices without an icon can be paired. The Bluetooth panel assigns an icon to the device name.

An icon with a red background indicates the device's Bluetooth connection is inactive.

An icon with a white background indicates the device is connected to the Thor VM1 and the device's Bluetooth connection is active.

Double-tap a device in the list to open the [device properties](#) menu. The target device does not need to be active.

Clear Button

Deletes all devices from the Device table that are not currently paired. A dialog box is presented, "Delete all disconnected devices? Tap the **Yes** button to remove disconnected or deleted devices from the device table. The devices are removed from the Device table after closing and reopening the Bluetooth window. Tap the **No** button to make no changes.

Bluetooth Device Menu

Pre-requisite: The Discover button has been clicked and there are Bluetooth devices listed.

Click on a device in the list to highlight it. Double-click the highlighted device to display the Bluetooth Device **right-click menu** as shown below. The Bluetooth device does not need to be active.



Right-Click Menu Options

Pair as Scanner	Receive data from the highlighted Bluetooth scanner or Bluetooth imager.
Pair as Printer	Send data to the highlighted Bluetooth printer.
Disconnect	Stop the connection between the Thor VM1 and the highlighted paired Bluetooth device.
Delete	Remove an unpaired device from the Bluetooth device list. The highlighted device name and identifier is removed from the Thor VM1 Bluetooth Devices panel after the user taps OK.
Properties	More information on the highlighted Bluetooth device.

Bluetooth Device Properties



Data on the Bluetooth Properties panel cannot be changed by the user. The data displayed is the result of the device Query performed during the Discovery process.

The Status dialog box reflects the current state of the highlighted device.

Settings

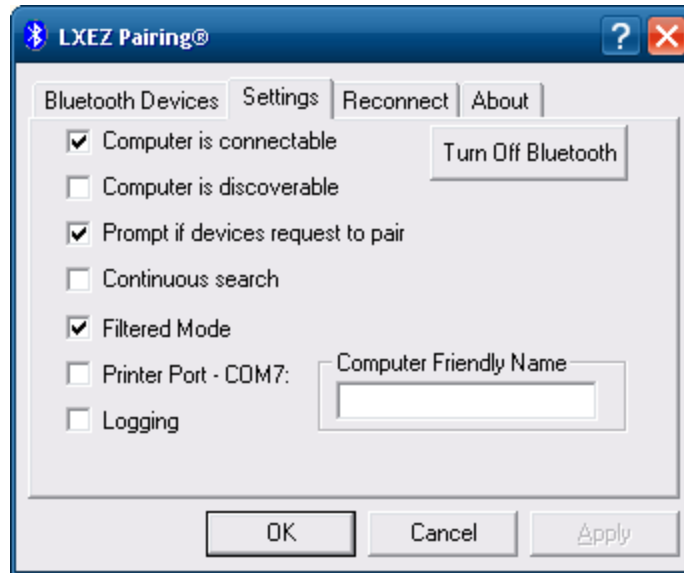

Note: These options can still be checked or unchecked whether Bluetooth connection is enabled or disabled.

Turn Off Bluetooth

Tap the button to toggle the Bluetooth client On or Off. The button title changes from *Turn Off Bluetooth* to *Turn On Bluetooth*.

Default

The default value is Bluetooth On.

Options

Option	Information
Computer is connectable	This option is Enabled by default. Disable this option to inhibit Thor VM1 connection initiated by a Bluetooth scanner.
Computer is discoverable	This option is Disabled by default. Enable this option to ensure other devices can discover the Thor VM1.
Prompt if devices request to pair	This option is Enabled by default. A dialog box appears on the Thor VM1 screen notifying the user a Bluetooth device requests to pair with the Thor VM1. The requesting Bluetooth device does not need to have been Discovered by the Thor VM1 before the pairing request is received. Tap the Accept button or the Decline button to remove the dialog box from the screen. In some cases, if a Bluetooth device is already paired this setting cannot be changed. If this is the case, an error message is displayed and the option is not changed. The Bluetooth device must be disconnected before changing this setting.
Continuous Search	This option is Disabled by default. When enabled, the Bluetooth connection never stops searching for a device it has paired with when the connection is broken (such as the paired device entering Suspend mode, going out of range or being turned off). When disabled, after being enabled, the Thor VM1 stops searching after 30 minutes.
Filtered Mode	This option is Enabled by default. Determines whether the Bluetooth client discovers and displays all serial Bluetooth devices in the vicinity (Filtered Mode is disabled/unchecked) or the discovery result displays Bluetooth scanners and printers only (Filtered Mode is enabled/checked). When Filtered Mode is disabled, the Thor VM1 can pair with up to four Bluetooth devices. A Restart is required every time Filtered Mode is toggled on and off. When in non-filtered mode, the Thor VM1 supports SPP only.
Printer Port - COM7	This option is Disabled by default. This option assigns Bluetooth printer connection to COM7 instead of COM19. To enable this option, Filtered Mode must be enabled.
Logging	This option is Disabled by default. When logging is enabled, the Thor VM1 creates <i>bt_log.txt</i> and stores it in the C:/Program Files/LXE/Bluetooth folder. Bluetooth activity logging is added to the text file as activity progresses. A <i>bt_log_bak.txt</i> file contains the data stored by <i>bt_log.txt</i> prior to reboot. During a reboot process, the Thor VM1 renames <i>bt_log.txt</i> to <i>bt_log_bak.txt</i> . If a file already exists with that name, the existing file is deleted, the new <i>bt_log_bak.txt</i> file is added and a new <i>bt_log.txt</i> is created.
Computer Friendly Name	Default: Computer description (Control Panel > System > Computer Name tab). The name, or identifier, entered in this space by the System Administrator is used exclusively by Bluetooth devices and during Bluetooth communication. The Computer Description field is blank by default, so unless this field is modified before Bluetooth is installed, Computer Friendly Name is also blank, but can be edited by the user.

Reconnect



Note: These options can still be checked or unchecked whether Bluetooth connection is enabled or disabled.

Options

Option	Function
Report when connection lost	<p>This option is Enabled (checked) by default.</p> <p>There may be an audio or visual signal when a connection between a paired, active device is lost.</p> <p>A visual signal may be a dialog box placed on the display notifying the user the connection between one (or all) of the paired Bluetooth devices has stopped. Tap the ok button to remove the dialog box from the screen.</p>
Report when reconnected	<p>This option is Disabled (unchecked) by default.</p> <p>There may be an audio or visual signal when a connection between a paired, active device is made.</p> <p>A visual signal may be a dialog box placed on the display notifying the user the connection between one (or all) of the paired Bluetooth devices has resumed. Tap the ok button to remove the dialog box from the screen.</p>
Report failure to reconnect	<p>This option is Enabled (checked) by default.</p> <p>The default time delay is 30 minutes. This value cannot be changed by the user.</p> <p>There may be an audio or visual signal when a connection between a paired, active device fails to re-connect. A visual signal may be a dialog box placed on the display notifying the user the connection between one (or all) of the previously paired Bluetooth devices has failed.</p> <p>Tap the X button or ok button to close the dialog box.</p> <p>Possible reasons for failure to reconnect: Timeout expired without reconnecting; attempted to pair with a device that is currently paired with another device; attempted to pair with a known device that moved out of range or was turned off; attempted to pair with a known device but the reason why reconnect failed is unknown.</p>
Clear Pairing Table on Boot	<p>This option is Disabled (unchecked) by default.</p> <p>When enabled (checked), all previous paired information is deleted upon any reboot sequence and no devices are reconnected.</p> <p>When enabled (checked) "Auto Reconnect on Boot" is automatically disabled (dimmed).</p>
Auto Reconnect on Boot	<p>This option is Enabled (checked) by default. All previously paired devices are reconnected upon any reboot sequence.</p> <p>When disabled (unchecked), no devices are reconnected upon any reboot sequence.</p>

Option	Function
Auto Reconnect	<p>This option is Enabled (checked) by default. This option controls the overall mobile Bluetooth device reconnect behavior.</p> <ul style="list-style-type: none"> • When Auto Reconnect is disabled (unchecked), <i>Auto Reconnect on Boot</i> is automatically disabled and dimmed. • When Auto Reconnect is disabled (unchecked), no devices are reconnected in any situation. The status of <i>Auto Reconnect on Boot</i> is ignored and no devices are reconnected on boot. The status of <i>Clear Pairing Table on Boot</i> controls whether the pairing table is populated on boot. • When Auto Reconnect is enabled (checked) and <i>Auto Reconnect on Boot</i> is disabled (unchecked), devices are not reconnected on boot, but are reconnected in other situations (example: return from out-of-range). • When Auto Reconnect is enabled (checked) and <i>Clear Pairing Table on Boot</i> is enabled (checked), devices are not reconnected on boot, but are reconnected in other situations (example: return from out-of-range). The pairing table is cleared on boot. The status of <i>Auto Reconnect on Boot</i> is ignored and the option is automatically disabled (unchecked) and dimmed.

About



This panel lists the assigned Computer Friendly Name (that other devices may discover during their Discovery and Query process), the Bluetooth MAC address, and software version levels. The data cannot be edited by the user.

Using Bluetooth

Start > Control Panel > Bluetooth or Bluetooth icon in taskbar or Bluetooth icon on desktop



or Tap the Bluetooth icon in the taskbar to open the Bluetooth LXEZPair application.



The Thor VM1 default Bluetooth setting is Enabled.

The Thor VM1 Bluetooth® module is designed to Discover and pair with nearby Bluetooth devices.

Prerequisite: The remote Bluetooth devices have been setup to allow them to be “Discovered” and “Connected/Paired”. The System Administrator is familiar with the pairing function of the remote Bluetooth devices.

Bluetooth Devices Display - Before Discovering Devices

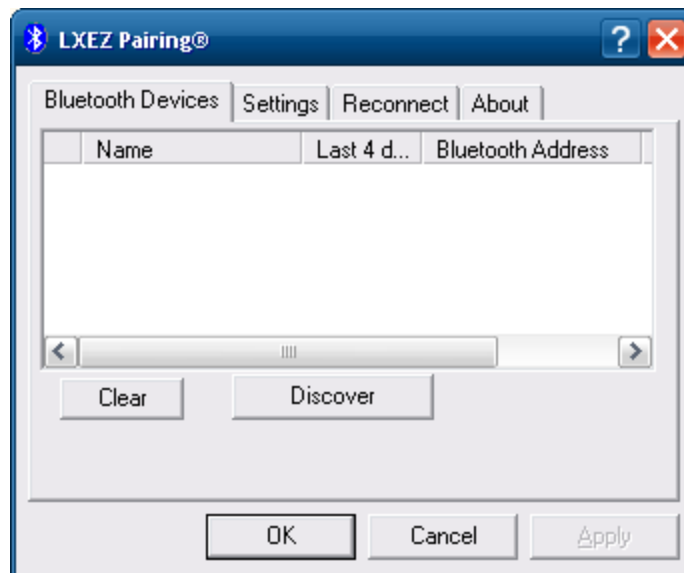

*Note: When **Filtered Mode** is enabled, only Bluetooth printers or Bluetooth scanners/imagers are recognized and displayed in the Bluetooth panel. All other Bluetooth devices are ignored.*

Initial Configuration

1. Select **Start > Control Panel > Bluetooth** or tap the Bluetooth icon in the taskbar or on the desktop.
2. Tap the **Settings** Tab.
3. Change the **Computer Friendly Name** at the bottom of the Settings display. The Bluetooth Thor VM1 default name is the Computer Description. Honeywell strongly urges assigning every Thor VM1 a unique name (up to 32 characters) before Bluetooth Discovery is initiated.
4. Check or uncheck the Thor VM1 Bluetooth options on the Settings tab.
5. Tap the OK button to save your changes or the X button to discard any changes.

Subsequent Use



Note: Taskbar and Bluetooth device Icon states change as Bluetooth devices are discovered, paired, connected and disconnected. A taskbar Bluetooth icon with a red background indicates Bluetooth is active and not paired with any device. A device icon with a red background indicates a disconnected paired device.

1. Tap the Bluetooth icon in the taskbar or on the desktop to open the Bluetooth LXEZ Pair application.
2. Tap the Bluetooth Devices tab.
3. Tap the Discover button. When the Bluetooth module begins searching for in-range Bluetooth devices, the button name changes to Stop. Tap the Stop button to cancel the Discover function at any time.
4. The discovered devices are listed in the Bluetooth Devices window.
5. Highlight a Bluetooth device in the Discovered window and double-tap to open the device properties menu.
6. Tap Pair as Scanner to set up the Thor VM1 to receive scanner data.
7. Tap Pair as Printer to set up the Thor VM1 to send data to the printer.
8. Tap Disconnect to stop pairing with the device. Once disconnected, tap Delete to remove the device name and data from the Thor VM1 Bluetooth Devices list. The device is deleted from the list after the OK button is clicked.
9. Upon successful pairing, the selected device may react to indicate a successful connection. The reaction may be an audio signal from the device, flashing LED on the device, or a dialog box is placed on the Thor VM1 display.
10. Whenever the Thor VM1 is turned On, all previously paired, live, Bluetooth devices in the vicinity are paired, one at a time, with the Thor VM1. If the devices cannot connect to the Thor VM1 before the re-connect timeout time period expires (default is approximately 20 seconds for each paired device) there is no indication of the continuing disconnect state if [Report Failure to Reconnect](#) is disabled.

Bluetooth Indicators

The Bluetooth taskbar Icon state changes as Bluetooth devices are discovered, paired, connected and disconnected.

There may be audible or visual signals as paired devices re-connect with the Thor VM1.

Taskbar Icon	Legend
	Thor VM1 is connected to one or more of the targeted Bluetooth device(s).
	Thor VM1 is not connected to any Bluetooth device. Thor VM1 is ready to connect with any Bluetooth device. Thor VM1 is out of range of all paired Bluetooth device(s). Connection is inactive.

Note: When an active paired device enters Suspend Mode, is turned Off or leaves the Thor VM1 Bluetooth scan range, the Bluetooth connection between the paired device and the Thor VM1 is lost. There may be audible or visual signals as paired devices disconnect from the Thor VM1.

Bluetooth LED	Legend
Blue, blinking slowly	Bluetooth is active but not connected to a device.
Blue, blinking medium	Bluetooth is paired and connected to a device.
Blue, blinking fast	Bluetooth is discovering other Bluetooth devices.
Off	Bluetooth hardware has been turned off or does not exist in the Thor VM1.

Bluetooth Bar Code Reader Setup

Please refer to the Bluetooth scanner manufacturer's User Guide; it may be available on the manufacturer's web site. Contact [Technical Assistance](#) for Bluetooth product assistance.

Honeywell supports several different types of bar code readers. This section describes the interaction and setup for a mobile Bluetooth laser scanner or laser imager connected to the Thor VM1 using Bluetooth functions.

Prerequisites

- The Thor VM1 has the Bluetooth hardware and software installed. An operating system upgrade may be required. Contact [Technical Assistance](#) for details.
- If the Thor VM1 has a Bluetooth address identifier bar code label affixed, then Bluetooth hardware and software is installed.
- The mobile Bluetooth laser scanner / laser imager battery is fully charged.
- The Thor VM1 is connected to AC or DC (vehicle) power.
- **Important:** *The bar code numbering examples in this segment are not real and should not be created nor scanned with a Bluetooth scanner.*
- To open the LXEZ Pair program, tap **Start > Control Panel > Bluetooth** or tap the Bluetooth icon on the desktop or tap the Bluetooth icon in the taskbar.



Locate the bar code label, similar to the one shown above, attached to the Thor VM1. The label is the Bluetooth address identifier for the Thor VM1.

The mobile Bluetooth scanner / imager requires this information before discovering, pairing, connecting or disconnecting can occur.

Important: The Thor VM1 Bluetooth address identifier label should remain protected from damage (rips, tears, spills, soiling, erasure, etc.) at all times. It may be required when pairing, connecting, and disconnecting new Bluetooth bar code readers.

Thor VM1 with Label

If the Thor VM1 has a Bluetooth address bar code label attached, follow these steps:

1. Scan the Bluetooth address bar code label, attached to the Thor VM1, with the Bluetooth mobile scanner.
2. If this is the first time the Bluetooth scanner has scanned the Thor VM1 Bluetooth label, the devices are paired. See section titled "[Bluetooth Beep and LED Indications](#)". If the devices do not pair successfully, go to the next step.
3. Open the LXEZ Pair panel (Start > Control Panel > Bluetooth).
4. Tap Discover. Locate the Bluetooth scanner in the Discovery panel.
5. Double-tap the stylus on the Bluetooth scanner. The right-mouse-click menu appears.
6. Select Pair as Scanner to pair the Thor VM1 with the Bluetooth mobile scanner.

The devices are paired. The Bluetooth bar code reader responds with a series of beeps and an LED flashes. Refer to the following section titled "[Bluetooth Beep and LED Indications](#)".

Note: After scanning the Thor VM1 Bluetooth label, if there is no beep and no LED flash from the Bluetooth device, the devices are currently paired.

Thor VM1 without Label

If the Thor VM1 Bluetooth address bar code label does not exist, follow these steps to create a unique Bluetooth address bar code for the Thor VM1:

First, locate the Thor VM1 Bluetooth address by tapping Start > Control Panel > Bluetooth > About tab.

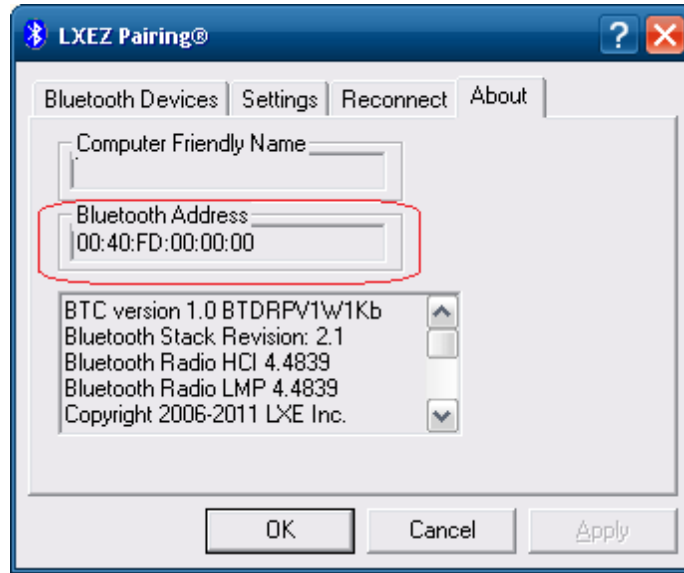

Next, [create¹](#) a Bluetooth address bar code label for the Thor VM1.

The format for the bar code label is as follows:

- Bar code type must be Code 128.
- FNC3 character followed by string Uppercase L, lowercase n, lowercase k, uppercase B and then the Bluetooth address (12 hex digits, no colons). For example, LnKB0400fd002031.

Create and print the label.

Scan the Thor VM1 Bluetooth address bar code label with the Bluetooth bar code reader.

The devices are paired. The Bluetooth bar code reader responds with a series of beeps and LED flashes.

Note: After scanning the Thor VM1 Bluetooth label, if there is no beep and no LED flash from the Bluetooth bar code reader, the devices are currently paired.

[See Also: "Bluetooth Beep and LED Indications"](#)

¹Free bar code creation software is available for download on the World Wide Web. Search using the keywords "bar code create".

Bluetooth Beep and LED Indications

Beep Type from Bluetooth Device	Behavior
Acknowledge label	1 beep
Label rejected	2 beeps at low frequency
Transmission error	Beep will sound high-low-high-low
Link successful	Beep will sound low-medium-high
Link unsuccessful	Beep will sound high-low-high-low

LED on Bluetooth Device	Behavior
Yellow LED blinks at 2 Hz	Linking in progress
Off	Disconnected or unlinked
Yellow LED blinks at 50 Hz	Bluetooth transmission in progress
Yellow LED blinks at the same rate as the paging beep (1 Hz)	Paging
Green LED blinks once a second	Disabled indication

Upon startup, if the Bluetooth device sounds a long tone, this means the Bluetooth device has not passed its automatic Selftest and has entered isolation mode. If the Bluetooth device is reset, the sequence is repeated. Contact [Technical Assistance](#) for assistance.

Bluetooth Printer Setup

The Bluetooth managed device should be as close as possible, in direct line of sight, with the Thor VM1 during the pairing process.

1. Open the LXEZ Pair Panel.
2. Tap Discover. Locate the Bluetooth printer in the Discovery panel.
3. Tap and hold the stylus (or double-tap) on the Bluetooth printer ID until the right-mouse-click menu appears.
4. Select Pair as Printer to pair the Thor VM1 with the Bluetooth managed printer.

The devices are paired. The Bluetooth managed printer may respond with a series of beeps or LED flashes.

Please refer to the Bluetooth managed printer manufacturer's User Guide; it may be available on the manufacturer's web site. Contact [Technical Assistance](#) for Bluetooth product assistance.

Note: If there is no beep or no LED flash from the Bluetooth managed printer, the Thor VM1 and the printer are currently paired.

Easy Pairing and Auto-Reconnect

The Bluetooth module can establish relationships with new devices after the user taps the Discover button. It can auto-reconnect to devices previously known but which have gone out of range and then returned within range (up to 32.8 ft (10 meters) Line of Sight).

Note: Configuration elements are persistent and stored in the registry.

Setup the Bluetooth module to establish how the user is notified by easy pairing and auto-reconnect events.

Display

Start > Control Panel > Display (Classic View)

Start > Control Panel > Appearance and Themes (Category View)

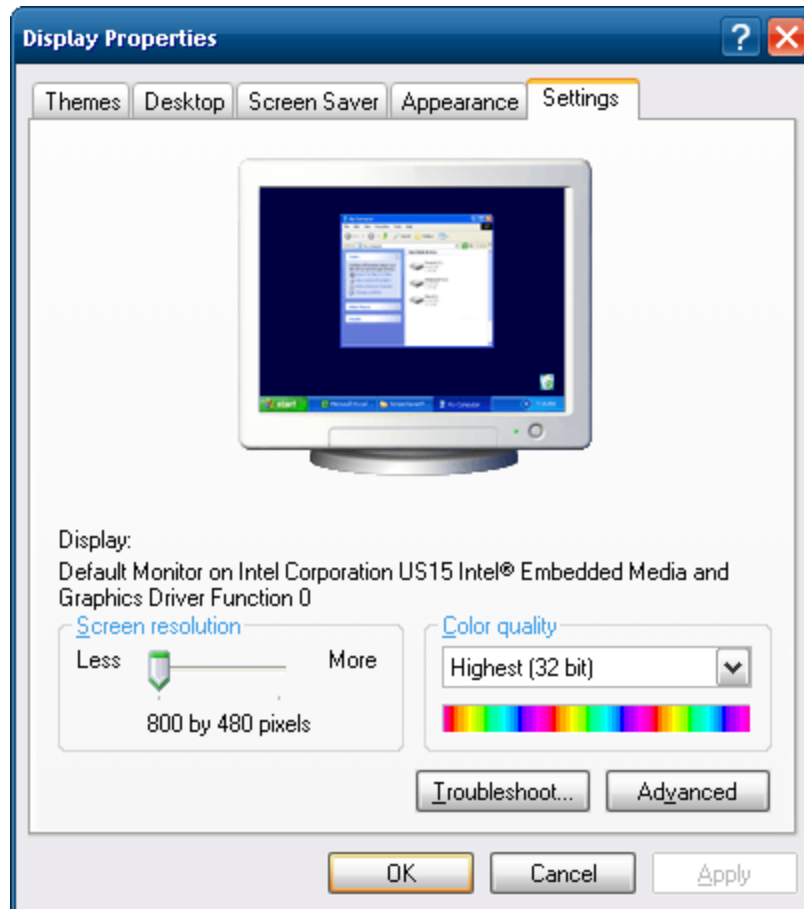

The Thor VM1 supports 800 x 480 pixel display resolution.

[Screen rotation](#) and other [configuration options](#) including Screen Blanking, Screen Defroster Control and Automatic Display Brightness (outdoor display only) are configured on separate control panels.

Power Options

Start > Control Panel > Power Options (Classic View)

Start > Control Panel > Performance and Maintenance > Power Options (Category View)

Power Schemes

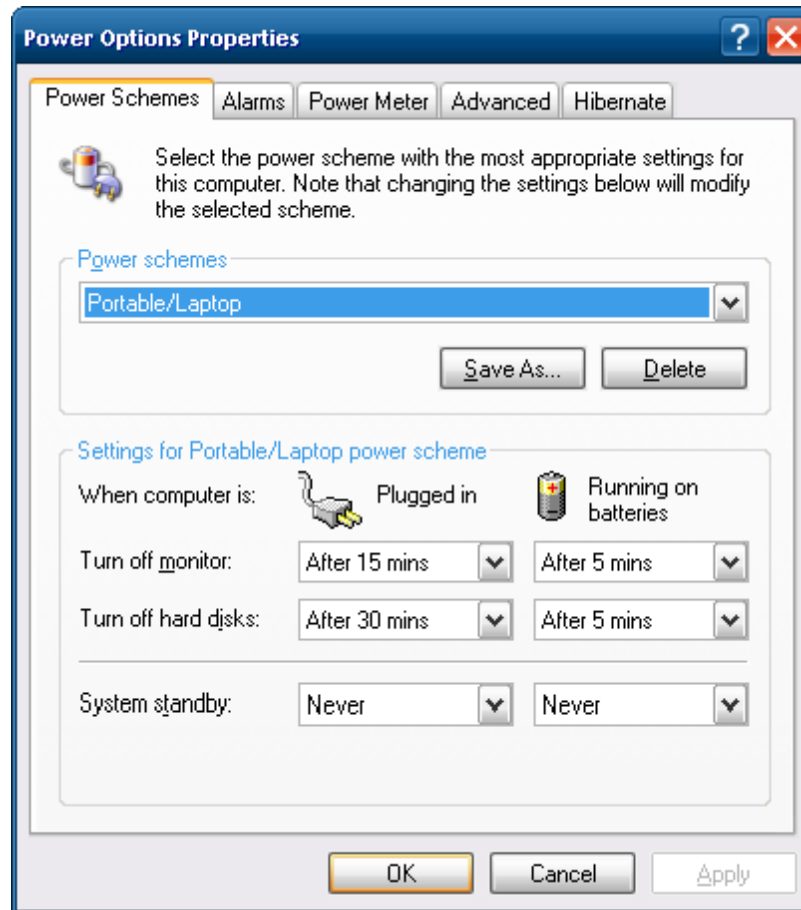

Power schemes can be configured that will be in effect when the Thor VM1 is attached to an external power supply or the UPS battery.

Power Meter

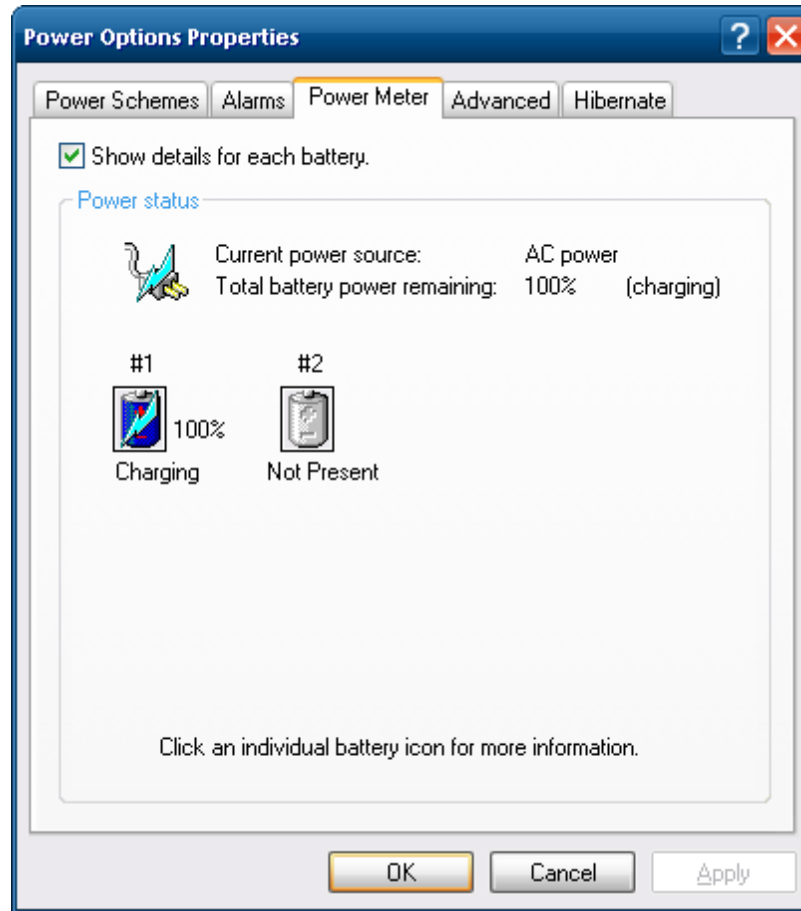

On the Power Meter tab, battery #1 refers to the UPS battery.

Shows power status: external power or UPS battery and the total battery power remaining before a recharge is necessary.

Advanced

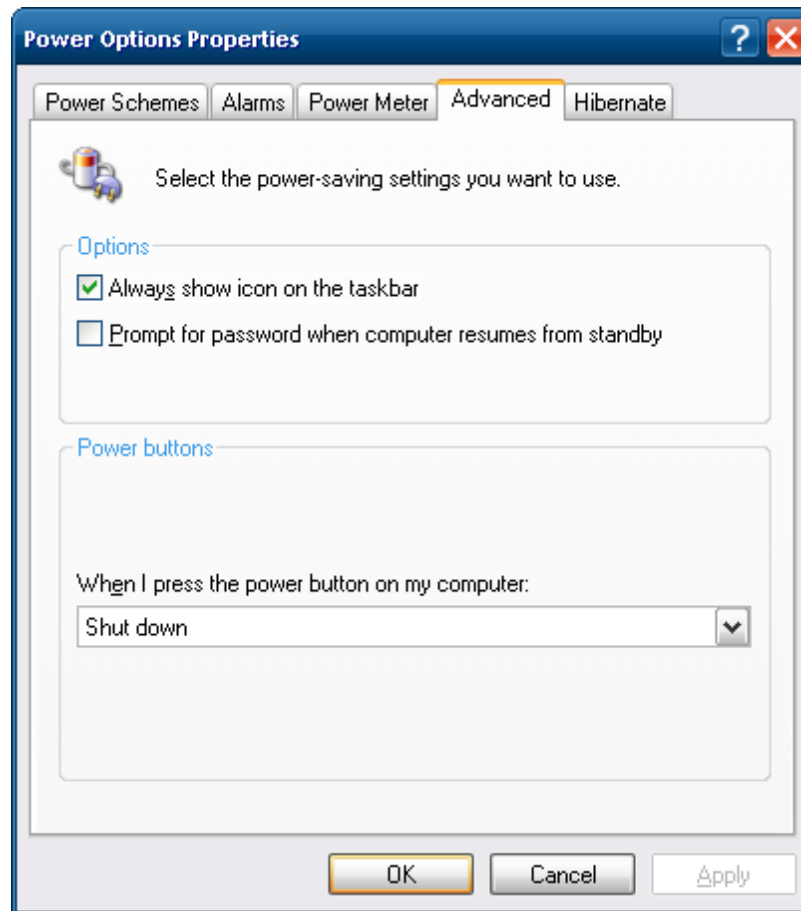

The **Advanced** panel allows setting the power button behavior when the unit is on and the power button is pressed. Options are:

- Do nothing
- Ask me what to do
- Stand by
- Shut down.

The default is to shut down. The Thor VM1 performs an orderly shut down when the power key is pressed when this option is enabled.

Hibernate

By default, hibernate is disabled on the Thor VM1. The default can be changed on this page.

The disk space necessary for hibernation plus the free disk space on the hard drive are listed.

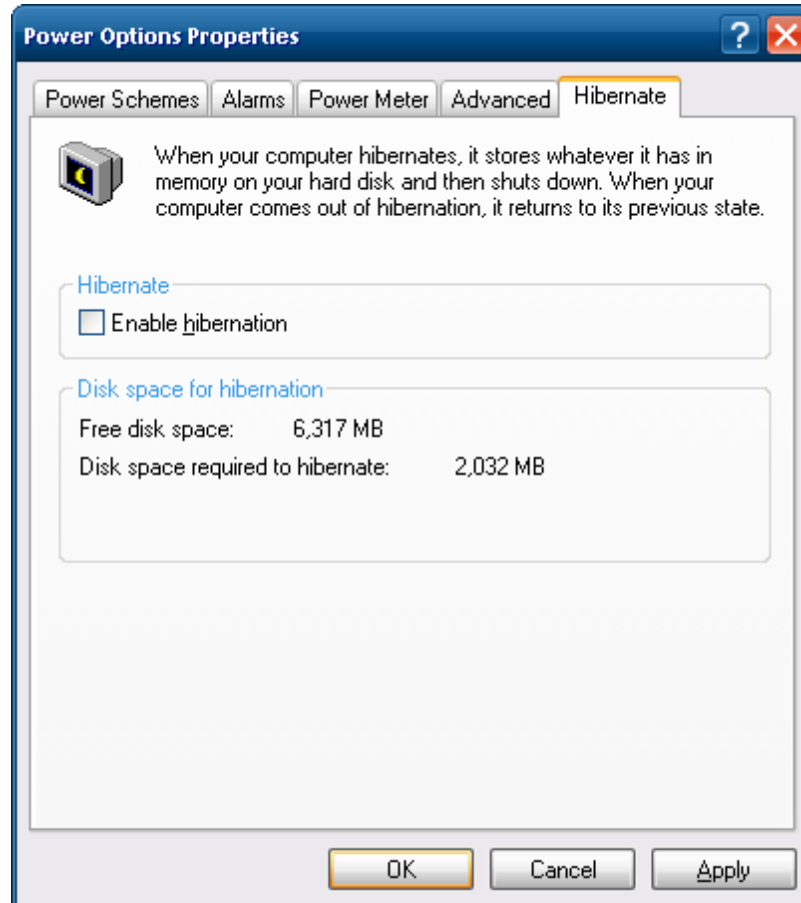

Screen Control

Start > Control Panel > Screen

Set screen properties for the Thor VM1.

Factory Default Settings

Screen Blanking (Blackout)	
Enable screen blanking	Enabled
Screen on delay (ms)	1000
COM Port	COM1
Automatic Brightness Control (for outdoor display only)	
Enable automatic brightness control	Disabled
Low to medium light level (%)	25
Medium to high light level (%)	75
Current Level	
LCD Brightness (%)	100 (see note)
Ambient Light (%)	(see note)
Defroster Control	
Enable defroster	Disabled
Trip point (°C)	40°C

Note: If Automatic Brightness Control is enabled for an outdoor display, the value for LCD Brightness depends on the Ambient Light %.

Note: There is no default value for Ambient Light % as it varies depending on the level of light where the Thor VM1 is located.

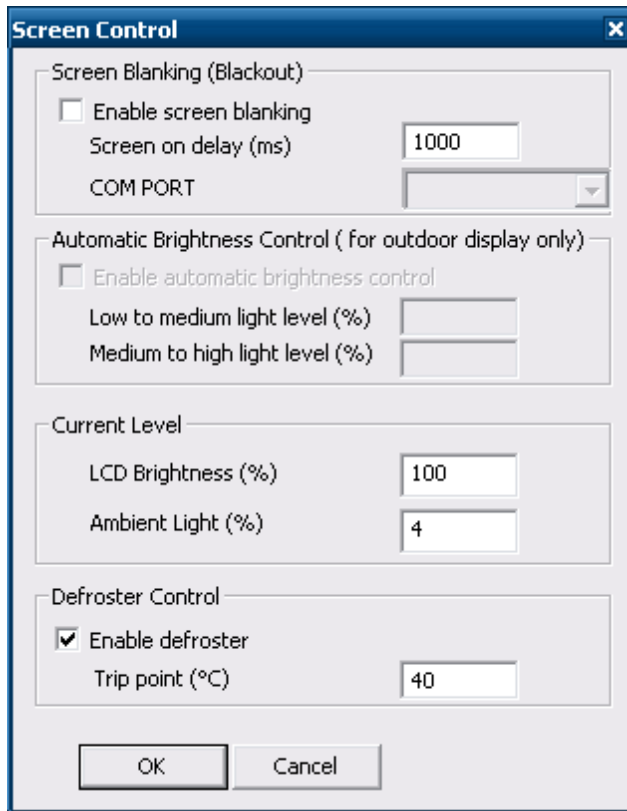

Screen Blanking

Screen blanking allows the Thor VM1 display to automatically be turned off whenever the vehicle is in motion.

Use the **Screen on delay** to specify the period of time in ms (milliseconds) between when the vehicle stops and the Thor VM1 screen turns on. For example, use the delay if the switch end of the cable is attached to the vehicle's accelerator pedal. Release of the accelerator may mean the truck is coasting to a stop rather than stationary. Configure the delay to allow time for the vehicle to coast to a stop. The default value is 1000 ms.

Specify the **COM Port** to which the screen blanking cable is attached. If a COM port is in use by another application, that COM port is grayed out and cannot be selected for screen blanking.



Do not enable **Screen Blanking** until the cable is properly connected to the specified COM port.

To disable screen blanking, uncheck the **Enable screen blanking** checkbox.

Screen blanking requires a [serial cable](#) and a [screen blanking box or switch](#).

Please refer to the wiring instructions, including appropriate cautions and warnings, in the *Thor VM1 Vehicle Mounting Reference Guide*.

Automatic Brightness Control

When the Thor VM1 is equipped with an **outdoor display**, automatic brightness control can be enabled. When enabled, display brightness is based on ambient light detected by the ambient light sensor, located near the top right of the display. The default is disabled. To enable, check the **Enable automatic brightness control** checkbox and specify the thresholds for display backlight transition.

When enabled, the thresholds can be entered for display brightness transitions.

- When a low level of ambient light is detected, the display backlight is set to low level.
- When the ambient light exceeds the threshold specified in **Low to medium light level (%)**, the display backlight is automatically increased to a medium level.
- When the ambient light exceeds the threshold specified in **Medium to high light level (%)**, the display backlight is automatically increased to a high level.
- Likewise if the Thor VM1 is returned to a lower ambient light area, the display backlight automatically transitions to the appropriate lower display backlight level.

Keypad Backlight

By default, the **keypad backlight** follows the display backlight. If the display backlight is on, the keypad backlight is on.

Current Level

Current levels of **LCD brightness** and **ambient light** are displayed as a percentage. Ambient light level is detected by the light sensor, located near the top right of the display.

Defroster Control

Enable the touch screen defroster, if installed, and set the trip point. Settings are ignored if the defroster is not installed.

If a defroster is installed, the defroster can be switched between the **Enabled** and **Disabled** states using the check box. The default is **Disabled** (unchecked).

Specify the Defroster **trip point**. The default trip point is 40°C/104°F.

Screen Rotation

Start > Control Panel > Screen Rotation (Classic view)

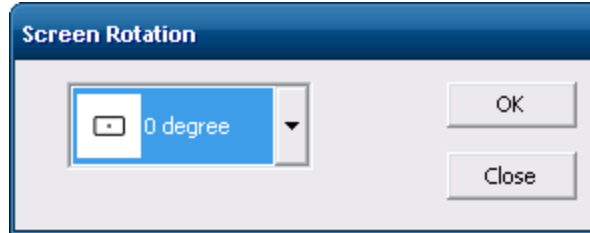

The Screen Rotation panel provides options for rotating the display:

0 Degree - Returns screen to the default orientation.

90 Degree - Rotates the screen counter clockwise 90 degrees as compared to the default orientation.

180 Degree - Rotates the screen 180 degrees as compared to the default orientation.

270 Degree - Rotates the screen counter clockwise 270 degrees as compared to the default orientation.

Select the desired rotation and tap **OK**. The screen may briefly go blank during the rotation process.

Tap **Close** to dismiss the panel and keep the current screen rotation.

Sounds

Start > Control Panel > Sounds and Audio Devices (Classic View)

Start > Control Panel > Sounds, Speech and Audio Devices (Category View)

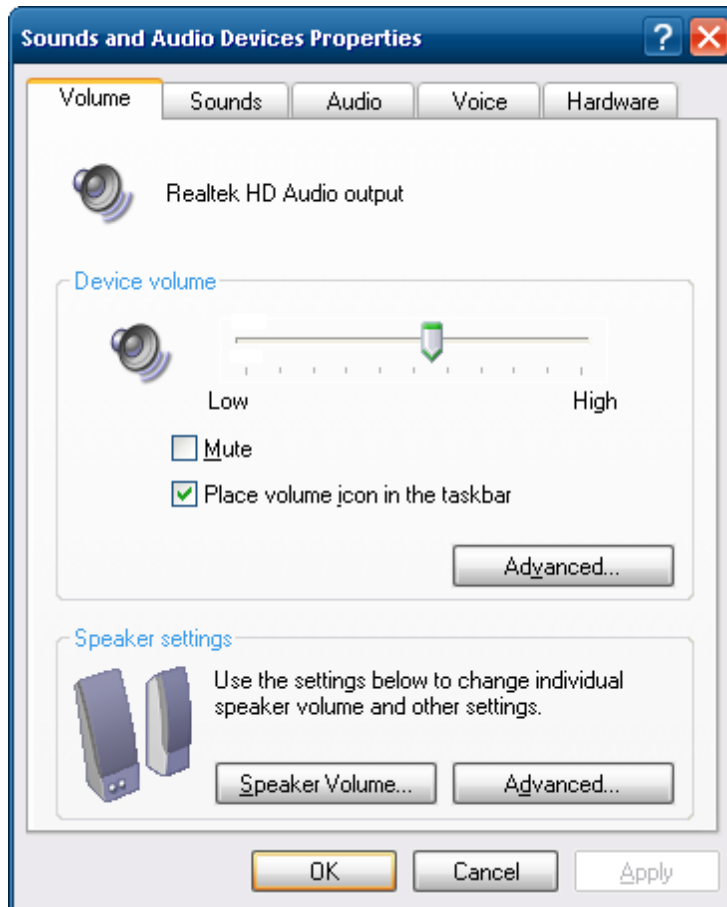

Use the slider bar to adjust the volume level as desired.

Alternatively:

- Tap the Volume icon, if present, in the taskbar and move the slider until the volume level is as desired.
- Use function keys - press the **2nd** key then **F9** to adjust volume up or **2nd** then **F10** to adjust volume down.

User Accounts

Note: The following applies to a Thor VM1 that is not part of a domain. When the Thor VM1 is part of a domain, the user is prompted for credentials at Windows startup or log on.

The Thor VM1 is pre-configured with an administrator account named Administrator. By default, the Thor VM1 automatically logs onto the Administrator account at Windows startup.

If the user assigns a password to the Administrator account:

- The password is stored and used when the Thor VM1 logs onto the Administrator account at Windows startup. The user is not prompted to enter a password.
- If the user logs off, the password must be manually entered to log back onto the Thor VM1.
- At the logon prompt, the user could specify a different user account (and password, if necessary) to log on, assuming the account has been added to the Thor VM1.
- When the Thor VM1 is restarted, the Administrator account automatically becomes the active user account, regardless of the active account before the restart.

If using the [Windows Certificate Store](#), the user must assign a password to the active (Administrator) account.

Wi-Fi

Start > Control Panel > Wi-Fi (Classic view)

Provides a shortcut to access the 802.11a/b/g/n radio configuration utility.

Tap the Wi-Fi icon to access the [Summit Client Utility \(SCU\)](#).

Bar Code Readers

The Thor VM1 can use the following external bar code readers:

- Tethered hand-held scanners are tethered to a [serial port](#) or a USB host port (via a dongle cable) on the Thor VM1 Quick Mount Smart Dock and are configured by scanning the engine-specific bar codes in the scanner manufacturer's programming guide. The manufacturer's guides are usually shipped with the bar code reader.
- Wireless hand-held Bluetooth scanners are configured by scanning the engine-specific bar codes in the scanner manufacturer's programming guide. The manufacturer's guides are usually shipped with the bar code reader.
- The body worn Bluetooth Ring Scanner module may be using a Symbol 4400 Ring Imager or a Symbol 955 Ring Scanner. The BTRS module is configured by scanning the bar codes in the Bluetooth Ring Scanner Guide.

Scanner Wedge

Honeywell provides Freefloat Link*One for bar code decoding needs on the Thor VM1 when equipped with a Windows Embedded Standard operating system. Click [here](#) for the Freefloat website which contains documentation on Freefloat Link*One.

Touch Screen Calibration

Start > Programs > PenMount Windows Universal Driver

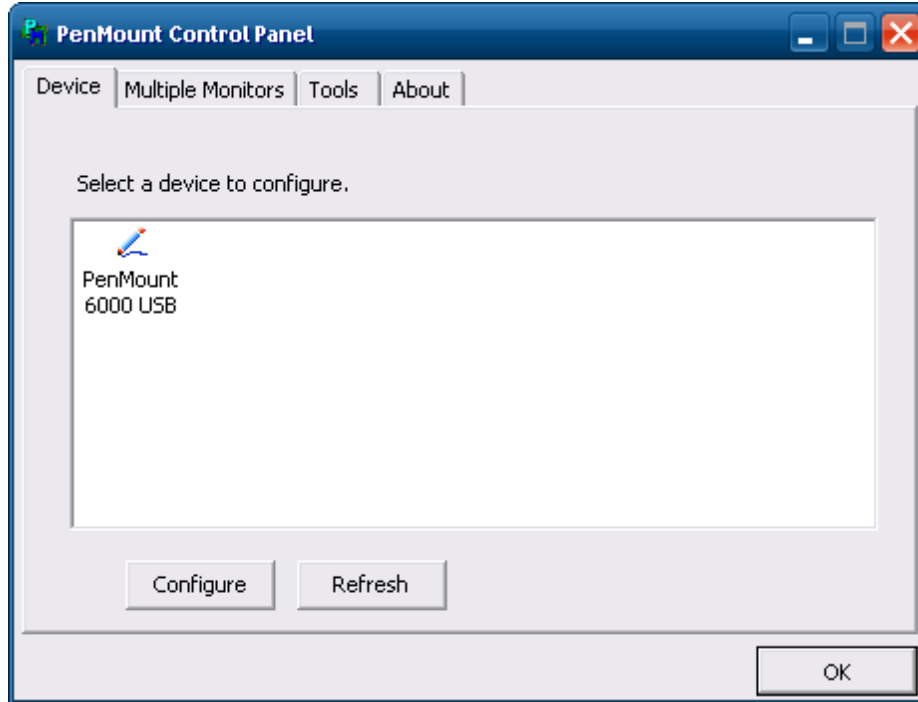

To calibrate the touch screen, tap **Start > Programs > PenMount Universal Driver > Utility > PenMount Control Panel**. Select **PenMount 6000 USB** and then tap **Configure**. Select Standard Calibration or Advance Calibration.

Advanced Calibration allows the user to select the number of calibration points. With either option, follow the on screen instructions to touch the red square, hold the touch and then lift the stylus to complete the calibration process.

BIOS

The Microsoft Windows Embedded Standard operating system is installed before shipping. The default BIOS parameters are configured at that time. In most cases, it is unnecessary to modify the BIOS parameters.

Generally, it is only necessary to enter the BIOS setup to change the boot order of the drives.

This section is not intended to detail all features of the BIOS, instead it is intended to cover the most commonly used setup options.

<p>Caution:</p> 	<p>Be very careful when using this utility to modify BIOS Setup parameters. The Thor VM1 may generate unexpected results when incorrect or conflicting parameter values are entered. Selecting incorrect or invalid options may require the Thor VM1 to be returned for repairs.</p> <p>The parameters should only be modified by Information Services personnel or the system administrator.</p>
---	---

Accessing the BIOS Setup

When the Embedded BIOS screen (Phoenix Technologies) is displayed press the **Del** key to enter BIOS setup.

Use the arrow keys to move around the screen.

Boot Order

To view or edit the boot order, select the **Boot** tab.

By default, the first device in the boot order is **USB Hard Drive**.

The second device is the **Windows CE Image**.

	<p>If a USB drive, such as a thumb drive is attached to the Thor VM1, the device attempts to boot from the USB drive:</p> <ul style="list-style-type: none">• If the USB drive contains a bootable sector, the Thor VM1 boots from the USB drive.• If the USB drive does not contain a bootable sector, the Thor VM1 does not boot. Remove the USB drive and boot the Thor VM1 again.
---	--

Exiting BIOS Setup

To exit the BIOS setup, select the **Exit** tab and select one of these options:

- Save Setting and Restart
- Exit Setup without Saving Changes
- Reload Factory-Defaults and Restart

The Thor VM1 Recovery DVD

A recovery DVD is available to restore the software on your Thor VM1 to the same state it had when it was shipped from the factory.

Contact [Technical Assistance](#) for information on the recovery DVD.

Upgrading the Thor VM1

There may be firmware and BIOS upgrades available for the Thor VM1. Contact [Technical Assistance](#) for upgrade information and instructions. In some cases, it may be necessary to upgrade firmware before upgrading the operating system.

Contact [Technical Assistance](#) for upgraded firmware or operating system files. Follow the upgrade instructions provided by Technical Assistance.

Caution



The Thor VM1 must be connected to external power before upgrading the BIOS, firmware or operating systems.

If the Thor VM1 is operating on UPS battery power, the upgrade process does not initiate and the Thor VM1 is not upgraded.



Chapter 4: Wireless Network Connections



Summit Wireless Network Configuration

The Summit client device is a Summit 802.11a/b/g/n radio, capable of 802.11a, 802.11b, 802.11g and 802.11n data rates. The radio can be configured for no encryption, WEP encryption or WPA security.

Security Options Supported are

- None
- WEP
- LEAP
- WPA-PSK
- WPA/LEAP
- PEAP-MSCHAP
- PEAP-GTC
- EAP-TLS
- EAP-FAST

Important Notes

	It is important that all dates are correct on the Thor VM1 and host computers when using any type of certificate. Certificates are date sensitive and if the date is not correct authentication will fail.
	It may be necessary to upgrade radio software in order to use certain Summit Client Utility (SCU) features. Contact Technical Assistance for details.
	When using the 802.11a radio, the U-NII 1 band is the preferred band for indoor operation. For regulatory domains in which the U-NII 3 band is allowed, the following channels are supported: 149, 153, 157 and 161. The AP must be configured accordingly.

After making any changes to the wireless configuration, restart the Thor VM1.

Summit Client Utility

Note: When making changes to profile or global parameters, the device should be restarted afterwards.

Start > All Programs > Summit > Summit Client Utility or

SCU Icon on Desktop or

Summit Tray Icon (if present) or

Wi-Fi Icon in the Windows Control Panel (if present)

The [Main Tab](#) provides information, admin login and active profile selection.

Profile specific parameters are found on the [Profile Tab](#). The parameters on this tab can be set to unique values for each profile.

The [Status Tab](#) contains information on the current connection.

The [Diags Tab](#) provides utilities to troubleshoot the radio.

Global parameters are found on the [Global Tab](#). The values for these parameters apply to all profiles.

Help

Help is available by clicking the ? icon in the title bar on most SCU screens.

The SCU help may also be accessed by selecting Start > Help and tapping the Summit Client Utility link. The SCU does not have to be accessed to view the help information using this option.

Summit Tray Icon

- Tray icon is not shown when the Thor VM1 is running Windows Embedded Standard.

The Windows Wireless icon (located in the taskbar) may not display a successful wireless connection. The SCU Main tab should be used to verify the success of the connection instead.

Wireless Zero Config Utility



Windows XP and Windows Embedded
Standard devices

- The WZC utility has an icon in the toolbar (see above) indicating the Wireless Zero Config application is enabled but the connection is inactive at this time (the device is not connected to a network). The WZC icon may not be visible until control is passed to the WZC utility as described below.
- You can use either the Wireless Zero Configuration Utility or the Summit Client Utility to connect to your network. The Summit Client Utility is recommended because the Wireless Zero Configuration Utility cannot control the complete set of security features of the radio.

How To: Use the Wireless Zero Config Utility

1. Select **ThirdPartyConfig** in the Active Profile drop down box on the [Main tab](#).
2. A message appears that a Power Cycle is required to make settings activate properly.
3. Tap **OK**.
4. Restart the Thor VM1.

The Summit Client Utility passes control to Wireless Zero Config and the WZC Wireless Information control panel. Using the options in the Wireless Zero Config panels, set up radio and security settings. There may be a slight delay before the Wireless Zero Config icon indicates the status of the connection.

How to: Switch Control to SCU

1. To switch back to SCU control, select any other profile except **ThirdPartyConfig** in the SCU Active Config drop down list on the [Main tab](#).
2. A message appears that a Power Cycle is required to make settings activate properly.
3. Tap **OK**.
4. Restart the Thor VM1.

Radio control is passed to the SCU.

Main Tab

Start > All Programs > Summit > Summit Client Utility > Main tab

Factory Default Settings

Admin Login	SUMMIT
Radio	Enabled
Active Config/Profile	Default
Regulatory Domain	FCC, ETSI or Worldwide

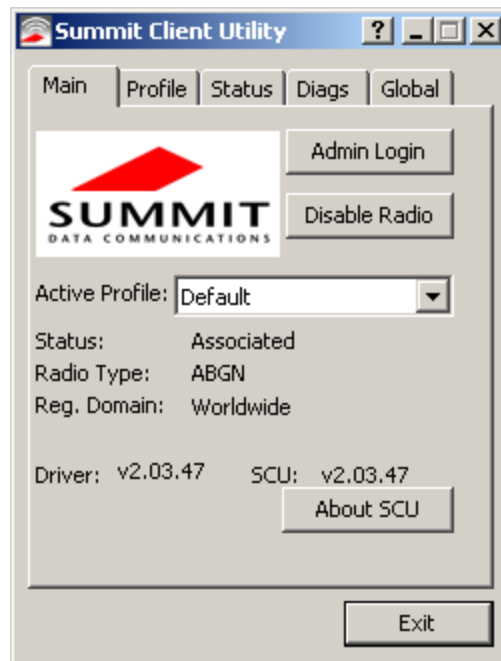

The Main tab displays information about the wireless client device including:

- SCU (Summit Client Utility) version
- Driver version
- Radio Type (ABGN is an 802.11 a/b/g/n radio).
- Regulatory Domain
- Copyright Information can be accessed by tapping the About SCU button
- Active Config profile / Active Profile name
- Status of the client (Down, Associated, Authenticated, etc.).

The **Active Profile** can be switched without logging in to Admin mode. Selecting a different profile from the drop down list does not require logging in to Administrator mode. The profile must already exist. Profiles can be created or edited after the Admin login password has been entered and accepted.

When the profile named "ThirdPartyConfig" is chosen as the active profile, the Summit Client Utility passes control to Wireless Manager for configuration of all client and security settings for the network module.

The **Disable Radio** button can be used to disable the network card. Once disabled, the button label changes to Enable Radio. By default the radio is enabled.

The **Admin Login** button provides access to editing wireless parameters. Profile and Global may only be edited after entering the Admin Login password.

The password is case-sensitive.

Once logged in, the button label changes to Admin Logout. To logout, either tap the **Admin Logout** button or exit the SCU without tapping the **Admin Logout** button.

Admin Login

To login to Administrator mode, tap the **Admin Login** button.

Once logged in, the button label changes to Admin Logout. The admin is automatically logged out when the SCU is exited. The Admin can either tap the **Admin Logout** button, or the **OK** button to logout.

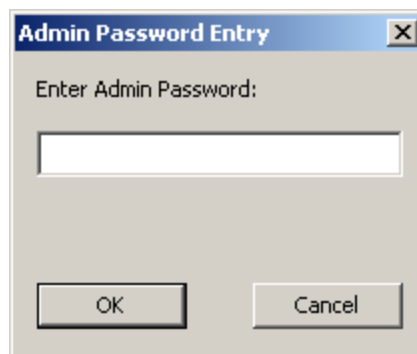

Enter the Admin password (the default password is SUMMIT and is case sensitive) and tap **OK**. If the password is incorrect, an error message is displayed.

The Administrator default password can be changed on the [Global](#) tab.

The end-user can:

- Turn the radio on or off on the Main tab.
- Select an active Profile on the Main tab.
- View the current parameter settings for the profiles on the [Profile](#) tab.
- View the global parameter settings on the [Global](#) tab.
- View the current connection details on the [Status](#) tab.
- View radio status, software versions and regulatory domain on the Main tab.
- Access additional troubleshooting features on the [Diags](#) tab.

After Admin Login, the end-user can also:

- Create, edit, rename and delete profiles on the [Profile](#) tab.
- Edit global parameters on the [Global](#) tab.
- Enable/disable the Summit tray icon in the taskbar.

Profile Tab

Start > All Programs > Summit > Summit Client Utility > Profile tab

Note: Tap the Commit button to save changes before leaving this panel or the SCU. If the panel is exited before tapping the Commit button, changes are not saved!

Factory Default Settings

Profile	Default
SSID	Blank
Client Name	Blank
Power Save	CAM
Tx Power	Maximum
Bit Rate	Auto
Radio Mode	See Profile Parameters for default
Auth Type	Open
EAP Type	None
Encryption	None

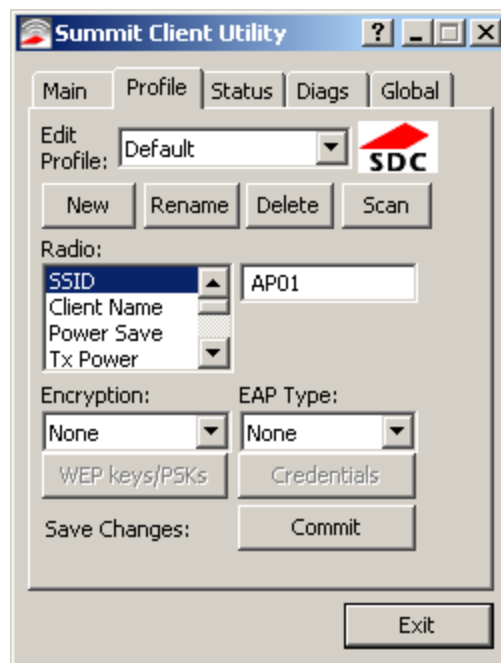

When logged in as an Admin (see [Admin Login](#)), use the Profile tab to manage profiles. When not logged in as an Admin, the parameters can be viewed, and cannot be changed. The buttons on this tab are dimmed if the user is not logged in as Admin. The Profile tab was previously labeled Config.

Buttons

Button	Function															
Commit	Saves the profile settings made on this screen. Settings are saved in the profile.															
Credentials	Allows entry of a username and password, certificate names, and other information required to authenticate with the access point. The information required depends on the EAP type.															
Delete	Deletes the profile. The current active profile cannot be deleted and an error message is displayed if a delete is attempted.															
New	Creates a new profile with the default settings (see Profile Parameters) and prompts for a unique name. If the name is not unique, an error message is displayed and the new profile is not created.															
Rename	Assigns a new, unique name. If the new name is not unique, an error message is displayed and the profile is not renamed.															
Scan	<p>Opens a window that lists access points that are broadcasting their SSIDs. Tap the Refresh button to view an updated list of APs. Each AP's SSID, its received signal strength indication (RSSI) and whether or not data encryption is in use (true or false). Sort the list by tapping on the column headers.</p> <p>If the scan finds more than one AP with the same SSID, the list displays the AP with the strongest RSSI and the least security.</p> <div data-bbox="667 934 1094 1341" data-label="Image"> <table border="1"> <thead> <tr> <th>SSID</th> <th>R...</th> <th>Se...</th> </tr> </thead> <tbody> <tr> <td>Net4</td> <td>-47</td> <td>true</td> </tr> <tr> <td>Net2</td> <td>-48</td> <td>true</td> </tr> <tr> <td>Net1</td> <td>-51</td> <td>true</td> </tr> <tr> <td>Net3</td> <td>-51</td> <td>false</td> </tr> </tbody> </table> <p>The screenshot shows a window titled 'Scan' with a close button (X) in the top right corner. Below the title bar is a table with three columns: 'SSID', 'R...' (RSSI), and 'Se...' (Security). The table contains four rows of data: Net4 (RSSI: -47, Security: true), Net2 (RSSI: -48, Security: true), Net1 (RSSI: -51, Security: true), and Net3 (RSSI: -51, Security: false). At the bottom of the window are two buttons: 'Configure' and 'Refresh'.</p> </div> <p>If you are logged in as an Admin, tap an SSID in the list and tap the Configure button, you return to the Profile window to recreate a profile for that SSID, with the profile name being the same as the SSID (or the SSID with a suffix such as “_1” if a profile with the SSID as its name exists already).</p>	SSID	R...	Se...	Net4	-47	true	Net2	-48	true	Net1	-51	true	Net3	-51	false
SSID	R...	Se...														
Net4	-47	true														
Net2	-48	true														
Net1	-51	true														
Net3	-51	false														
WEP Keys / PSK Keys	Allows entry of WEP keys or pass phrase as required by the type of encryption.															

Note: Unsaved Changes – The SCU will display a reminder if the Commit button is not clicked before an attempt is made to close or browse away from this tab.

Important – The settings for Auth Type, EAP Type and Encryption depend on the security type chosen.

Profile Parameters

Parameter	Default	Explanation
Edit Profile	Default	A string of 1 to 32 alphanumeric characters, establishes the name of the Profile. Options are Default or ThirdPartyConfig.
SSID	Blank	A string of up to 32 alphanumeric characters. Establishes the Service Set Identifier (SSID) of the WLAN to which the client connects.
Client Name	Blank	A string of up to 16 characters. The client name is assigned to the network card and the device using the network card. The client name may be passed to networking wireless devices, e.g. Access Points.
Power Save	CAM	Power save mode. Options are: Constantly Awake Mode (CAM) power save off, Maximum (power saving mode) and Fast (power saving mode). When using power management, use FAST for best throughput results.
Tx Power	Maximum	Maximum setting regulates Tx power to the Max power setting for the current regulatory domain. Options are: Maximum, 50mW, 30mW, 20mW, 10mW, 5mW, or 1mW.
Bit Rate	Auto	Setting the rate to Auto will allow the Access Point to automatically negotiate the bit rate with the client device. Options are: Auto, 1 Mbit, 2, 5.5, 6, 9, 11, 12, 18, 24, 36, 48 or 54 Mbit.
Auth Type	Open	802.11 authentication type used when associating with the Access Point. Options are: Open, LEAP, or Shared key.
EAP Type	None	Extensible Authentication Protocol (EAP) type used for 802.1x authentication to the Access Point. Options are: None, LEAP, EAP-FAST, PEAP-MSCHAP, PEAP-GTC, PEAP-TLS, EAP-TTLS, or EAP-TLS. <i>Note: EAP Type chosen determines whether the Credentials button is active and also determines the available entries in the Credentials pop-up window.</i>
Encryption	None	Type of encryption to be used to protect transmitted data. Available options may vary by SCU version. Options are: None, WEP (or Manual WEP), WEP EAP (or Auto WEP), WPA PSK, WPA TKIP, WPA CCKM, WPA2 PSK, WPA2 AES, or WPA2 CCKM. CKIP is not supported in the Thor VM1. <i>Note: The Encryption type chosen determines if the WEP Keys / PSK Keys button is active and also determines the available entries in the WEP or PSK pop-up window.</i>
Radio Mode	BGA Rates Full	Specify 802.11a, 802.11b and/or 802.11g rates when communicating with the AP. The options displayed for this parameter depend on the type of radio installed in the mobile device. Options: B rates only (1, 2, 5.5 and 11 Mbps) BG Rates Full (All B and G rates) G rates only (6, 9, 12, 18, 24, 36, 48 and 54 Mbps) BG optimized or BG subset (1, 2, 5.5, 6, 11, 24, 36 and 54 Mbps) A rates only (6, 9, 12, 18, 24, 36, 48 and 54 Mbps) ABG Rates Full (All A rates and all B and G rates with A rates preferred) BGA Rates Full (All B and G rates and all A rates with B and G rates preferred)

Parameter	Default	Explanation
		Ad Hoc (when connecting to another client device instead of an AP) Default: BGA Rates Full (for 802.11a/b/g/n radio)

It is important the **Radio Mode** parameter correspond to the AP to which the device is to connect. For example, if this parameter is set to G rates only, the Thor VM1 may only connect to APs set for G rates and not those set for B and G rates.

Contact [Technical Assistance](#) if you have questions about the antenna(s) installed on your Thor VM1.

Status Tab

Start > All Programs > Summit > Summit Client Utility > Status tab

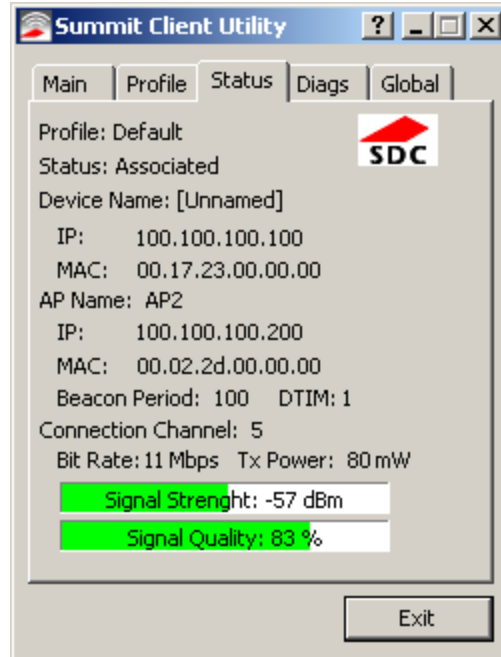

This screen provides information on the radio:

- The profile being used.
- The status of the radio card (down, associated, authenticated, etc.).
- Client information including device name, IP address and MAC address.
- Information about the Access Point (AP) maintaining the connection to the network including AP name, IP address and MAC address.
- Channel currently being used for wireless traffic.
- Bit rate in Mbit.
- Current transmit power in mW.
- Beacon period – the time between AP beacons in kilomicroseconds. (one kilomicrosecond = 1,024 microseconds).
- DTIM interval – A multiple of the beacon period that specifies how often the beacon contains a delivery traffic indication message (DTIM). The DTIM tells power saving devices a packet is waiting for them. For example, if DTIM = 3, then every third beacon contains a DTIM.
- Signal strength (RSSI) displayed in dBm and graphically.
- Signal quality, a measure of the clarity of the signal displayed in percentage and graphically.

There are no user entries on this screen.

Note: After completing radio configuration, it is a good idea to review this screen to verify the radio has associated (no encryption, WEP) or authenticated (LEAP, any WPA), as indicated above.

Diags Tab

Start > All Programs > Summit > Summit Client Utility > Diags tab

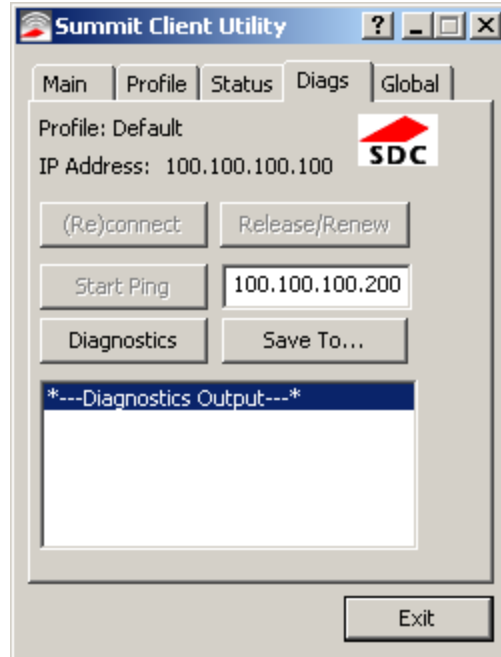

The Diags screen can be used for troubleshooting network traffic and radio connectivity issues.

- **(Re)connect** – Use this button to apply (or reapply) the current profile and attempt to associate or authenticate to the wireless LAN. All activity is logged in the Diagnostic Output box on the lower part of the screen.
- **Release/Renew** – Obtain a new IP address through release and renew. All activity is logged in the Diagnostic Output box. If a fixed IP address has been assigned to the radio, this is also noted in the Diagnostic Output box. Note that the current IP address is displayed above this button.
- **Start Ping** – Start a continuous ping to the IP address specified in the text box to the right of this button. Once the button is clicked, the ping begins and the button label changes to **Stop Ping**. Clicking the button ends the ping. The ping also ends when any other button on this screen is clicked or the user browses away from the Diags tab. The results of the ping are displayed in the Diagnostic Output box.
- **Diagnostics** – Also attempts to (re)connect to the wireless LAN. However, this option provides more data in the Diagnostic Output box than the (Re)connect option. This data dump includes radio state, profile settings, global settings, and a list of broadcast SSID APs.
- **Save To...** – Use this to save the results of the diagnostics to a text file. Use the explorer window to specify the name and location for the diagnostic file. The text file can viewed using an application such as WordPad.

Global Tab

Start > All Programs > Summit > Summit Client Utility > Global tab

The parameters on this panel can only be changed when an [Admin is logged in](#) with a password. The current values for the parameters can be viewed by the general user without requiring a password.

Note: Tap the Commit button to save changes. If the panel is exited before tapping the Commit button, changes are not saved!

Factory Default Settings

Roam Trigger	-65 dBm
Roam Delta	5 dBm
Roam Period	10 sec.
BG Channel Set	Full
DFS Channels	Off
DFS Scan Time	120 ms.
Ad Hoc Channel	1
Aggressive Scan	On
CCX Features	Optimized
WMM	On
Auth Server	Type 1
TTLS Inner Method	Auto-EAP
PMK Caching	Standard
WAPI	Off (dimmed)
TX Diversity	On
RX Diversity	On Start on Main
Frag Threshold	2346
RTS Threshold	2347
LED	Off
Tray Icon	On
Hide Passwords	On
Admin Password	SUMMIT (or blank)
Auth Timeout	8 seconds
Certs Path	C:\Program Files\Summit\certs
Ping Payload	32 bytes
Ping Timeout	5000 ms
Ping Delay ms	1000 ms

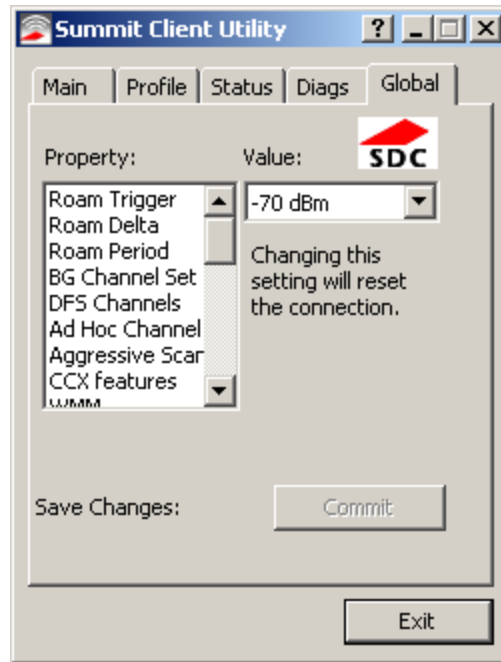

Custom Parameter Option

The parameter value is displayed as "Custom" when the operating system registry has been edited to set the Summit parameter to a value that is not available from the parameter's drop down list. Selecting Custom from the drop down list has no effect. Selecting any other value from the drop down list will overwrite the "custom" value in the registry.

Global Parameters

Parameter	Default	Function
Roam Trigger	-65 dBm	If signal strength is less than this trigger value, the client looks for a different Access Point with a stronger signal. Options are: -50 dBm, -55, -60, -65, -70, -75, -80, -85, -90 dBm or Custom .
Roam Delta	5 dBm	The amount by which a different Access Point signal strength must exceed the current Access Point signal strength before roaming to the different Access Point is attempted. Options are: 5 dBm, 10, 15, 20, 25, 30, 35 dBm or Custom .
Roam Period	10 sec.	The amount of time, after association or a roam scan with no roam, that the radio collects Received Signal Strength Indication (RSSI) scan data before a roaming decision is made. Options are: 5 sec, 10, 15, 20, 25, 30, 35, 40, 45, 50, 55, 60 seconds or Custom .
BG Channel Set	Full	Defines the 2.4GHz channels to be scanned for an AP when the radio is contemplating roaming. By specifying the channels to search, roaming time may be reduced over scanning all channels. Options are: Full (all channels) 1,6,11 (the most commonly used channels) 1,7,13 (for ETSI and TELEC radios only) Custom .
DFS Channels	Off	Support for 5GHZ 802.11a channels where support for DFS is required. Options are: On, Off, Optimized. <i>Note: Not supported (always off) in some releases.</i>
DFS Scan Time	120 ms.	ABG radio only. The amount of time the radio will passively scan each DFS channel to see if it will receive a beacon. Recommended value is 1.5 times that of the AP's beacon period.
Ad Hoc Channel	1	Use this parameter when the Radio Mode profile parameter is set to Ad Hoc. Specifies the channel to be used for an Ad Hoc connection to another client device. If a channel is selected that is not supported by the by the radio, the default value is used. Options are: 1 through 14 (the 2.4GHz channels) 36, 40, 44, 48 (the UNII-1 channels)
Aggressive Scan	On	When set to On and the current connection to an AP weakens, the radio aggressively scans for available APs. Aggressive scanning works with standard scanning (set through Roam Trigger, Roam Delta and Roam Period). Aggressive scanning should be set to On unless there is significant co-channel interference due to overlapping APs on the same channel.

Parameter	Default	Function
		Options are: On, Off
CCX or CCX Features	Optimized	Use of Cisco Compatible Extensions (CCX) radio management and AP specified maximum transmit power features. Options are: Full - Use Cisco IE and CCX version number, support all CCX features. The option known as "On" in previous versions. Optimized –Use Cisco IE and CCX version number, support all CCX features except AP assisted roaming, AP specified maximum transmit power and radio management. Off - Do not use Cisco IE and CCX version number. Cisco IE = Cisco Information Element.
WMM	On	Use of Wi-Fi Multimedia extensions. Devices running Windows XP can change the default value. Devices running all other OS cannot change the default value.
Auth Server	Type 1	Specifies the type of authentication server. Options are: Type 1 (ACS server) and Type 2 (non-ACS server)
TTLS Inner Method	Auto-EAP	Authentication method used within the secure tunnel created by EAP-TTLS. Options are: AUTO-EAP (Any available EAP method) MSCHAPV2 MSCHAP PAP CHAP EAP-MSCHAPV2
PMK Caching	Standard	Type of Pairwise Master Key (PMK) caching to use when WPA2 is in use. PMK caching is designed to speed up roaming between APs by allowing the client and the AP to cache the results of 802.1X authentications, eliminating the need to communicate with the ACS server. Standard PMK is used when there are no controllers. The reauthentication information is cached on the original AP. The client and the AP use the cached information to perform the four-way handshake to exchange keys. Opportunistic PMK (OPMK) is used when there are controllers. The reauthentication information cached on the controllers. The client and the controller behind the AP use the cached information to perform the four-way handshake to exchange keys. If the selected PMK caching method is not supported by the network infrastructure, every roam requires full 802.11X authentication, including interaction with the ACS server. If the active profile is using WPA2 CCKM, the global PMK Caching setting is ignored and the client attempts to use CCKM. Options are: Standard, OPMK
WAPI	Off	Default is Off and dimmed (cannot be changed).

Parameter	Default	Function
TX Diversity	On	How to handle antenna diversity when transmitting packets to the Access Point. Options are: Main only, and On.
RX Diversity	On Start on Main	How to handle antenna diversity when receiving packets from the Access Point. Option is: On-start on Main <i>Note: This parameter cannot be changed for some Summit radios.</i>
Frag Thresh	2346	If the packet size (in bytes) exceeds the specified number of bytes set in the fragment threshold, the packet is fragmented (sent as several pieces instead of as one block). Use a low setting in areas where communication is poor or where there is a great deal of wireless interference. Options are: Any number between 256 bytes and 2346 bytes.
RTS Thresh	2347	If the packet size exceeds the specified number of bytes set in the Request to Send (RTS) threshold, an RTS is sent before sending the packet. A low RTS threshold setting can be useful in areas where many client devices are associating with the Access Point. This parameter cannot be changed.
LED	Off	The LED on the wireless card is not visible to the user when the wireless card is installed in a sealed mobile device. Options are: On, Off.
Tray Icon	On	Determines if the Summit icon is displayed in the System tray. Options are: On, Off <i>The tray icon is not displayed when the Thor VM1 is running a Windows Embedded Standard operating system.</i>
Hide Password	On	When On, the Summit Config Utility masks passwords (characters on the screen are displayed as an *) as they are typed and when they are viewed. When Off, password characters are not masked. Options are: On, Off.
Admin Password	SUMMIT (or Blank)	A string of up to 64 alphanumeric characters that must be entered when the Admin Login button is tapped. If Hide Password is On, the password is masked when typed in the Admin Password Entry dialog box. The password is case sensitive. This value is masked when the Admin is logged out. Options are: none.
Auth Timeout	8 seconds	Specifies the number of seconds the Summit software waits for an EAP authentication request to succeed or fail. If the authentication credentials are stored in the active profile and the authentication times out, the association fails. No error message or prompting for corrected credentials is displayed. If the authentication credentials are not stored in the active profile and the authentication times out, the user is again prompted to enter the credentials. Options are: An integer from 3 to 60.

Parameter	Default	Function
Certs Path	certificates	A valid directory path, of up to 64 characters, where WPA Certificate Authority and User Certificates are stored on the mobile device when not using the Windows certificates store. Ensure the Windows folder path exists before assigning the path in this parameter. See Certificates for instructions on obtaining CA and User Certificates. This value is masked when the Admin is logged out. Options are: none. The complete path is C:\Program Files\Summit\certs
Ping Payload	32 bytes	Maximum amount of data to be transmitted on a ping. Options are: 32 bytes, 64, 128, 256, 512, or 1024 bytes.
Ping Timeout ms	5000	The amount of time, in milliseconds, that a device will be continuously pinged. The Stop Ping button can be tapped to end the ping process ahead of the ping timeout. Options are: Any number between 0 and 30000 ms.
Ping Delay ms	1000	The amount of time, in milliseconds, between each ping after a Start Ping button tap. Options are: Any number between 0 and 30000 ms.
Logon Options	SCU	Use SCU or Windows login credentials. More info.

Note: Tap the Commit button to save changes. If this panel is closed before tapping the Commit button, changes are not saved!

Logon Options

This option is only available on devices with a Windows XP Professional or Windows Embedded Standard operating system.

There are two options available, a [single signon](#) which uses the Windows username and password as the credentials for 802.1x authentication and [pre-logon](#) which uses saved credentials for 802.1x authentication before Windows logon.

If either option is enabled, the credentials entered here take precedence over any credentials entered on the [Profile](#) tab.

To use either option, select **Logon Options** from the **Property** list which activates the **Logon Options** button.

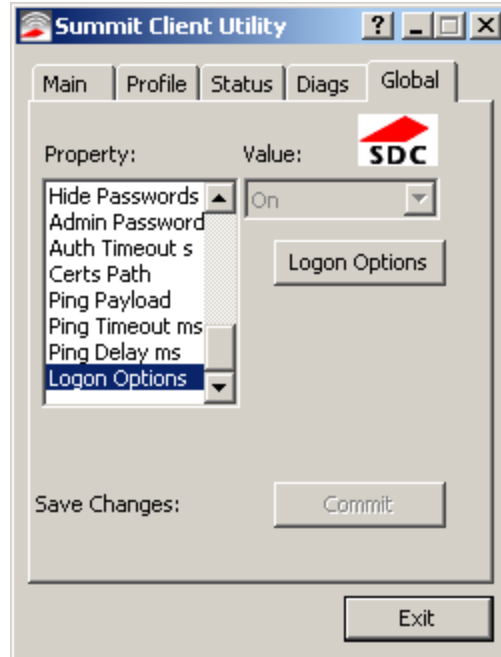

Click the **Logon Options** button.

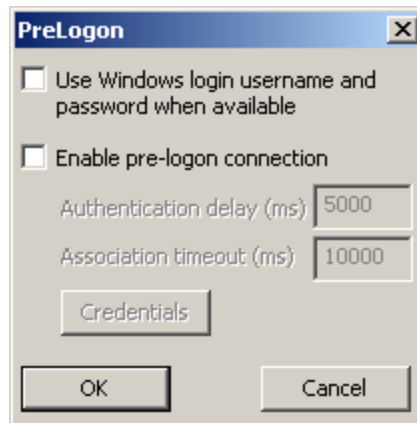

Single Signon

To use the Single Signon option, select the checkbox for **Use the Windows username and password when available**. When the active profile is using LEAP, PEAP-MSCHAP, PEAP-GTC or EAP-FAST, the SCU ignores the username and password, if any, saved in the profile. Instead, the username and password used for Windows logon is used. Any certificates needed for authentication must still be specified in the profile.

Click **OK** then click **Commit**.

Pre-Logon Connection

To use the Pre_logon connection, select the checkbox for Enable pre-logon connection. This option is designed to be used when:

-
- EAP authentication is required for a WLAN connection
 - Single Signon is configured, so the Windows username and password are used as credentials for EAP authentication
 - The WLAN connection needs to be established before the Windows login.

Once this option is enabled, the **Authentication delay** and **Association timeout** values can be adjusted as necessary. Both values are specified in milliseconds (ms).

The default authentication delay is 5000 ms and the valid range is 0 - 600,000 ms.

The default association timeout is 10,000 ms and the valid range is 10,000 to 600,000 ms.

Click on the **Credentials** button to enter the logon credentials.

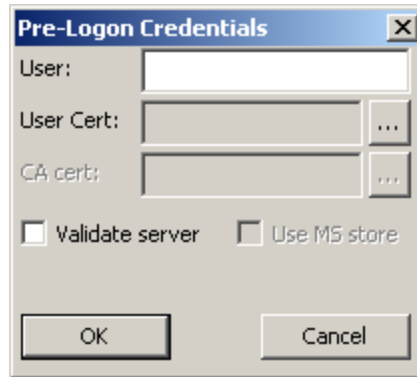

If using the Windows certificate store:

- Check the **Use MS store** checkbox. The default is to use the Full Trusted Store.
- To select an individual certificate, click on the **Browse** button.
- Uncheck the **Use full trusted store** checkbox.
- Select the desired certificate and click **Select**. You are returned to the Credentials screen.

If using the Certs Path option:

- Leave the Use MS store box unchecked.
- Enter the certificate filename in the CA Cert textbox.

Click **OK** then click **Commit**.

Sign-On vs. Stored Credentials

When using wireless security that requires a user name and password to be entered, the Summit Client Utility offers these choices:

- The Username and Password may be entered on the Credentials screen. If this method is selected, anyone using the device can access the network.
- The Username and Password are left blank on the Credentials screen. When the device attempts to connect to the network, a sign on screen is displayed. The user must enter the Username and Password at that time to authenticate.
- When using Summit with the Thor VM1, there is an option on the [Global](#) tab to use the Windows user name and password to log on instead of any username and password stored in the profile.

How to: Use Stored Credentials

1. After completing the other entries in the profile, click on the **Credentials** button.
2. Enter the Username and Password on the Credentials screen and click the **OK** button.
3. Click the **Commit** button.
4. For LEAP and WPA/LEAP, configuration is complete.
5. For PEAP-MSCHAP and PEAP-GTC, importing the CA certificate into the Windows certificate store is optional.
6. For EAP-TLS, import the CA certificate into the Windows certificate store. Also import the User Certificate into the Windows certificate store.
7. Access the Credentials screen again. Make sure the **Validate server** and **Use MS store** checkboxes are checked.
8. The default is to use the entire certificate store for the CA certificate. Alternatively, use the **Browse** button next to the CA Cert (CA Certificate Filename) on the Credentials screen to select an individual certificate.
9. For EAP-TLS, also enter the User Cert (User Certificate filename) on the credentials screen by using the **Browse** button.
10. If using EAP FAST and manual PAC provisioning, input the PAC filename and password..
11. Click the **OK** button then the **Commit** button.
12. If changes are made to the stored credentials, click **Commit** to save those changes before making any additional changes to the profile or global parameters.
13. Verify the device is authenticated by reviewing the Status tab. When the device is property configured, the Status tab indicates the device is Authenticated and the method used.

Note: See [Configuring the Profile](#) for more details.

Note: If invalid credentials are entered into the stored credentials, the authentication will fail. No error message is displayed. The user may or may not be prompted to enter valid credentials.

How to: Use Sign On Screen

1. After completing the other entries in the profile, click on the **Credentials** button. Leave the Username and Password blank. No entries are necessary on the Credentials screen for LEAP or LEAP/WPA.
2. For PEAP-MSCHAP and PEAP-GTC, importing the CA certificate into the Windows certificate store is optional.
3. For EAP-TLS, import the CA certificate into the Windows certificate store. Also import the User Certificate into the Windows certificate store.
4. Access the Credentials screen again. Make sure the **Validate server** and **Use MS store** checkboxes are checked.

-
5. The default is to use the entire certificate store for the CA certificate. Alternatively, use the Browse button next to the CA Cert (CA Certificate Filename) on the Credentials screen to select an individual certificate.
 6. For EAP-TLS, also enter the User Cert (User Certificate filename) on the credentials screen by using the **Browse** button.
 7. Click the **OK** button then the **Commit** button.
 8. When the device attempts to connect to the network, a sign-on screen is displayed.
 9. Enter the Username and Password. Click the **OK** button.

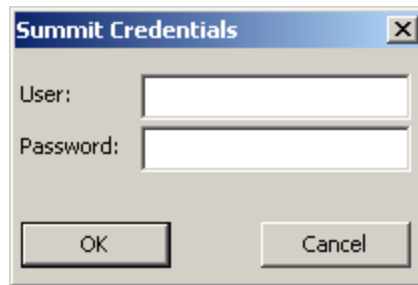

10. Verify the device is authenticated by reviewing the Status tab. When the device is properly configured, the [Status Tab](#) indicates the device is Authenticated and the method used.
11. The sign-on screen is displayed after a reboot.

Note: See [Configuring the Profile](#) for more details.

If a user enters invalid credentials and clicks **OK**, the device associates but does not authenticate. The user is again prompted to enter credentials.

If the user clicks the **Cancel** button, the device does not associate. The user is not prompted again for credentials until:

- the device is rebooted,
- the radio is disabled then enabled,
- the **Reconnect** button on the [Diags Tab](#) is clicked or
- the profile is modified and the **Commit** button is clicked.

How to: Use Windows Username and Password

Please see [Logon Options](#) for information.

Windows Certificate Store vs. Certs Path

Note: It is important that all dates are correct on the Thor VM1 and host computers when using any type of certificate. Certificates are date sensitive and if the date is not correct authentication will fail.



If using the Windows Certificate Store, the Windows Account must have a password. The password cannot be left blank. The Summit Client Utility uses the Windows user account credentials to access the Certificate Store. The Windows user account credentials need not be the same as the [wireless credentials](#) entered in the Summit Client Utility.

User Certificates

EAP-TLS authentication requires a user certificate. The user certificate must be stored in the Windows certificate store.

- To generate the user certificate, see [Generating a User Certificate](#).
- To import the user certificate into the Windows certificate store, see [Installing a User Certificate](#).
- A Root CA certificate is also needed. Refer to the section below.

Root CA Certificates

Root CA certificates are required for EAP/TLS, PEAP/GTC and PEAP/MSCHAP. Two options are offered for storing these certificates. They may be imported into the Windows certificate store or copied into the Certs Path directory.

How To: Use the Certs Path

1. See [Generating a Root CA Certificate](#) and follow the instructions to download the Root Certificate to a PC.
2. Copy the certificate to specified directory on the mobile device. The default location for Certs Path is C:\Program Files\Summit\certs. A different location may be specified by using the Certs Path global variable.
3. When completing the Credentials screen for the desired authentication, do not check the **Use MS store** checkbox after checking the **Validate server** checkbox.
4. Enter the certificate name in the CA Cert textbox.
5. Click **OK** to exit the Credentials screen and then **Commit** to save the profile changes.

How To: Use Windows Certificate Store

1. See [Generating a Root CA Certificate](#) and follow the instructions to download the Root Certificate to a PC.
2. To import the certificate into the Windows store, See [Installing a Root CA Certificate](#).
3. When completing the Credentials screen for the desired authentication, be sure to check the **Use MS store** checkbox after checking the **Validate server** checkbox.
4. The default is to use all certificates in the store. If this is OK, skip to the last step.
5. Otherwise, to select a specific certificate click on the **Browse (...)** button.

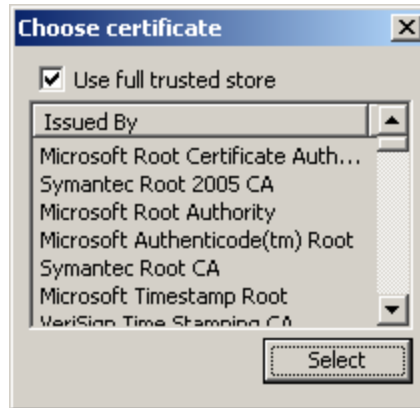

6. Uncheck the **Use full trusted store** checkbox.
7. Select the desired certificate and click the **Select** button to return the selected certificate to the CA Cert textbox.
8. Click **OK** to exit the Credentials screen and then **Commit** to save the profile changes.

Configuring the Profile

Use the instructions in this section to complete the entries on the Profile tab according to the type of wireless security used by your network. The instructions that follow are the minimum required to successfully connect to a network. Your system may require more parameters than are listed in these instructions. Please see your system administrator for complete information about your network and its wireless security requirements.

To begin the configuration process:

- On the [Main Tab](#), click the [Admin Login](#) button and enter the password.
- If using a single profile, edit the default profile with the parameters for your network. Select the Default profile from the pull down menu.
- Make any desired parameter changes as described in the applicable following section determined by network security type and click the **Commit** button to save the changes.

IMPORTANT – Remember to click the Commit button after making changes to ensure the changes are saved. Many versions of the SCU display a reminder if the Commit button is not clicked before an attempt is made to close or browse away from the tab in focus if there are unsaved changes.

If changes are made to the *stored credentials*, click Commit to save those changes first before making any additional changes.

No Security

To connect to a wireless network with no security, make sure the following profile options are used.

- Enter the **SSID** of the Access Point assigned to this profile
- Set **EAP Type** to **None**
- Set **Encryption** to **None**
- Set **Auth Type** to **Open**

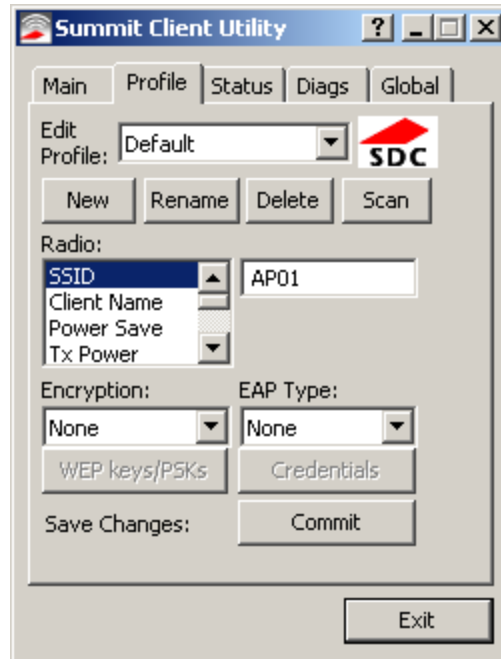

Once configured, click the **Commit** button.

Ensure the correct Active Profile is selected on the [Main tab](#) and restart. The SCU Main tab shows the device is associated after the radio connects to the network.

WEP

To connect using WEP, make sure the following profile options are used.

- Enter the **SSID** of the Access Point assigned to this profile
- Set **EAP Type** to **None**
- Set **Encryption** to **WEP** or **Manual WEP** (depending on SCU version)
- Set **Auth Type** to **Open**

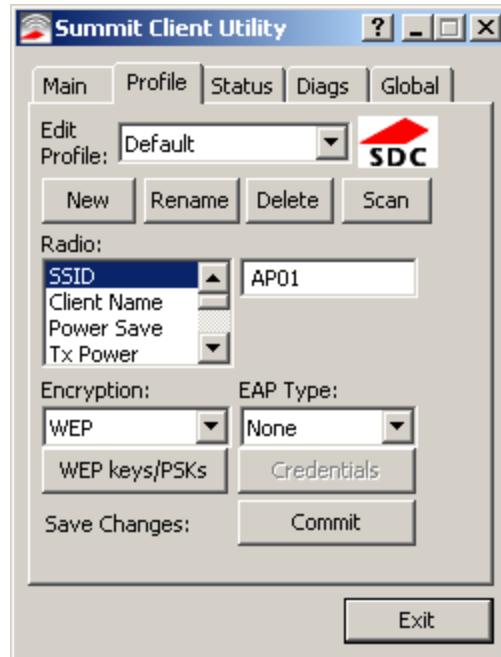

Click the **WEP keys/PSKs** button.

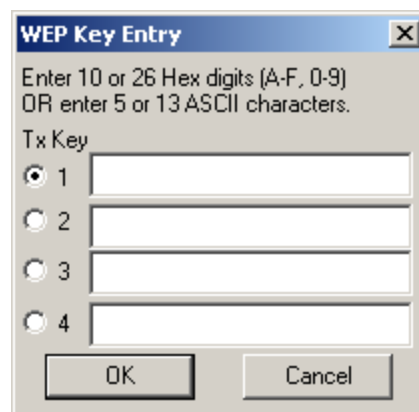

Valid keys are 10 hexadecimal or 5 ASCII characters (for 40-bit encryption) or 26 hexadecimal or 13 ASCII characters (for 128-bit encryption). Enter the key(s) and click **OK**.

Once configured, click the **Commit** button.

Ensure the correct Active Profile is selected on the [Main tab](#) and restart. The SCU Main tab shows the device is associated after the radio connects to the network.

LEAP

To use LEAP (without WPA), make sure the following profile options are used.

- Enter the **SSID** of the Access Point assigned to this profile
- Set **EAP Type** to **LEAP**
- Set **Encryption** to **WEP EAP** or **Auto WEP** (depending on SCU version)
- Set **Auth Type** as follows:
 - If the Cisco/CCX certified AP is configured for open authentication, set the **Auth Type** radio parameter to **Open**.
 - If the AP is configured to use shared key or passphrase, set the Auth Type radio parameter to **Shared**.
 - If the AP is configured for network EAP only, set the **Auth Type** radio parameter to **LEAP**.

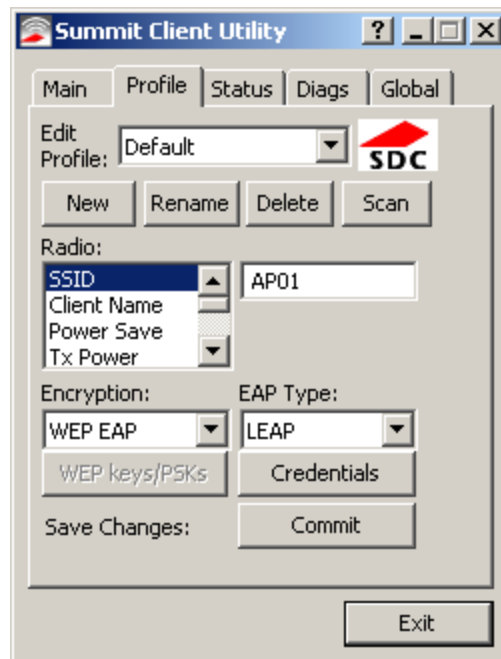

See [Sign-On vs. Stored Credentials](#) for information on entering credentials.

To use Stored Credentials, click on the **Credentials** button. No entries are necessary for Sign-On Credentials as the user will be prompted for the Username and Password when connecting to the network.

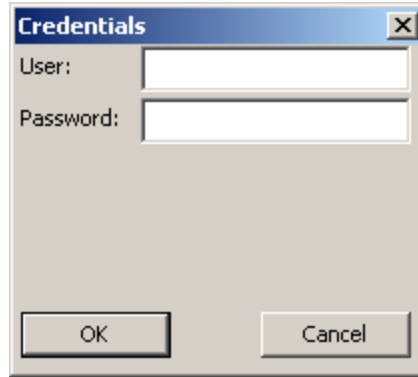

Enter the Domain\Username (if the Domain is required), otherwise enter the Username.

Enter the password. Click **OK** then click **Commit**.

Ensure the correct Active Profile is selected on the [Main tab](#) and restart. The SCU Main tab shows the device is associated after the radio connects to the network.

PEAP/MSCHAP

To use PEAP/MSCHAP, make sure the following profile options are used.

- Enter the **SSID** of the Access Point assigned to this profile
- Set **EAP Type** to **PEAP-MSCHAP**
- Set **Encryption** to **WPA TKIP**
- Set **Auth Type** to **Open**

To use another encryption type, select WPA CCKM, WPA2 AES or WPA2 CCKM for encryption and complete other entries as detailed in this section.

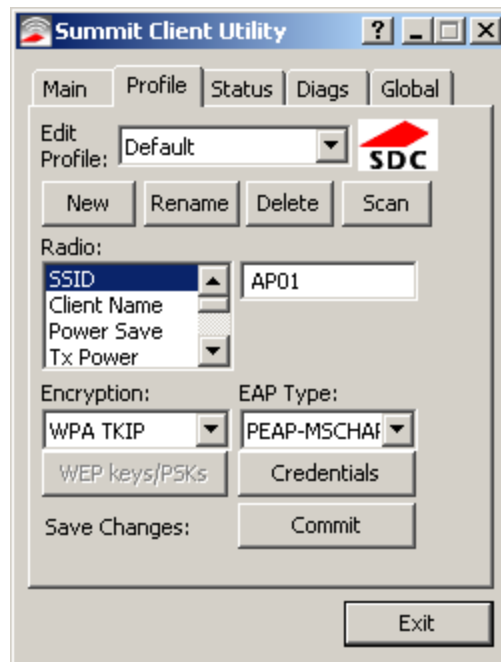

See [Sign-On vs. Stored Credentials](#) for information on entering credentials.

Click the **Credentials** button.

- No entries except the CA Certificate Filename are necessary for Sign-On Credentials as the user will be prompted for the User Name and Password when connecting to the network.
- For Stored Credentials, User, Password and the CA Certificate Filename must be entered.

Enter these items as directed below.

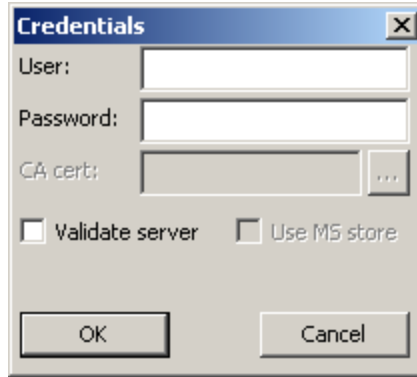

Enter the Domain\Username (if the Domain is required), otherwise enter the Username.

Enter the password.

Leave the CA Certificate File Name blank for now.

Click **OK** then click **Commit**. Ensure the correct Active profile is selected on the [Main Tab](#).

See [Windows Certificate Store vs. Certs Path](#) for more information on certificate storage.

Once successfully authenticated, import the CA certificate into the Windows certificate store. Return to the Credentials screen and check the **Validate server** checkbox.

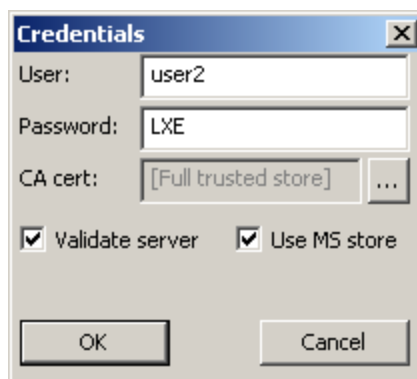

If using the Windows certificate store:

- Check the **Use MS store** checkbox. The default is to use the Full Trusted Store.
- To select an individual certificate, click on the **Browse** button.
- Uncheck the **Use full trusted store** checkbox.
- Select the desired certificate and click Select. You are returned to the Credentials screen.

If using the Certs Path option:

- Leave the **Use MS store** box unchecked.
- Enter the certificate filename in the CA Cert textbox.

Click **OK** then click **Commit**.

The device should be authenticating the server certificate and using PEAP/MSCHAP for the user authentication.

Ensure the correct Active Profile is selected on the [Main tab](#) and restart. The SCU Main tab shows the device is associated after the radio connects to the network.

Note: The date must be properly set on the device to authenticate a certificate.

PEAP/GTC

To use PEAP/GTC, make sure the following profile options are used.

- Enter the **SSID** of the Access Point assigned to this profile
- Set **EAP Type** to **PEAP-GTC**
- Set **Encryption** to **WPA TKIP**
- Set **Auth Type** to **Open**

To use another encryption type, select WPA CCKM, WPA2 AES or WPA2 CCKM for encryption and complete other entries as detailed in this section.

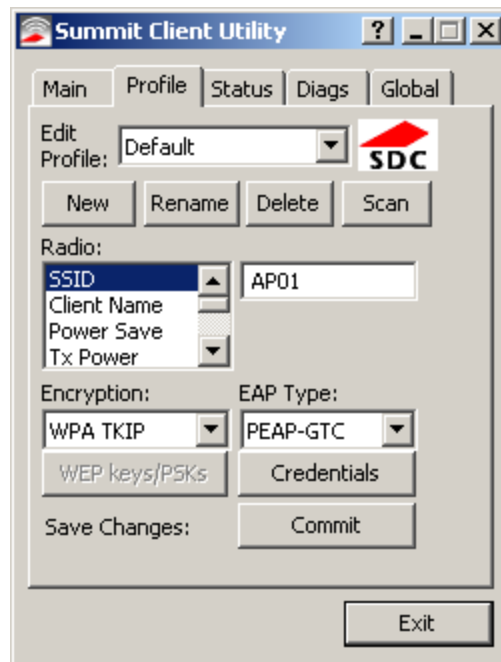

See [Sign-On vs. Stored Credentials](#) for information on entering credentials.

Click the **Credentials** button.

- No entries except the CA Certificate Filename are necessary for Sign-On Credentials as the user will be prompted for the User Name and Password when connecting to the network.

Enter these items as directed below.

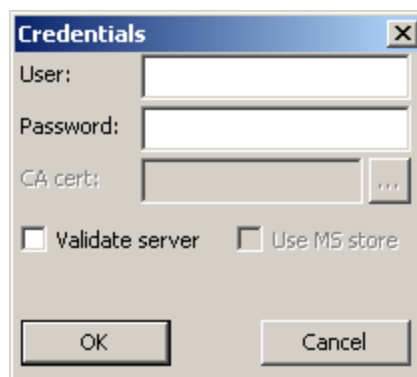

Enter the Domain\Username (if the Domain is required), otherwise enter the Username.

Enter the password.

Leave the CA Certificate File Name blank for now.

Click **OK** then click **Commit**. Ensure the correct Active Profile is selected on the [Main Tab](#).

See [Windows Certificate Store vs. Certs Path](#) for more information on certificate storage.

Once successfully authenticated, import the CA certificate into the Windows certificate store. Return to the Credentials screen and check the **Validate server** checkbox.

Note: Some servers may be configured to allow only a single use of the password for PEAP/GTC. In this case, wait for the token to update with a new password before attempting to validate the server. Then enter the new password, check the Validate Server checkbox and proceed with the certificate process below.

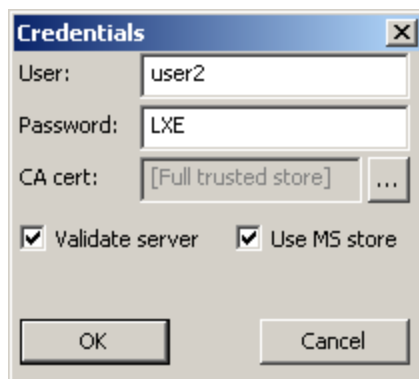

If using the Windows certificate store:

- Check the **Use MS store** checkbox. The default is to use the Full Trusted Store.
- To select an individual certificate, click on the **Browse** button.
- Uncheck the **Use full trusted store** checkbox.
- Select the desired certificate and click **Select**. You are returned to the Credentials screen.

If using the Certs Path option:

- Leave the **Use MS store box** unchecked.
- Enter the certificate filename in the CA Cert textbox.

Click **OK** then click **Commit**.

The device should be authenticating the server certificate and using PEAP/GTC for the user authentication.

Ensure the correct Active Profile is selected on the [Main tab](#) and restart. The SCU Main tab shows the device is associated after the radio connects to the network.

Note: The date must be properly set on the device to authenticate a certificate.

WPA/LEAP

To use WPA/LEAP, make sure the following profile options are used.

- Enter the **SSID** of the Access Point assigned to this profile
- Set **EAP Type** to **LEAP**
- Set **Encryption** to **WPA TKIP**
- Set **Auth Type** as follows:
 - If the Cisco/CCX certified AP is configured for open authentication, set the **Auth Type** radio parameter to **Open**.
 - If the AP is configured to use shared key or passphrase, set the Auth Type radio parameter to **Shared**.
 - If the AP is configured for network EAP only, set the **Auth Type** radio parameter to **LEAP**.

To use another encryption type, select WPA CCKM, WPA2 AES or WPA2 CCKM for encryption and complete other entries as detailed in this section.

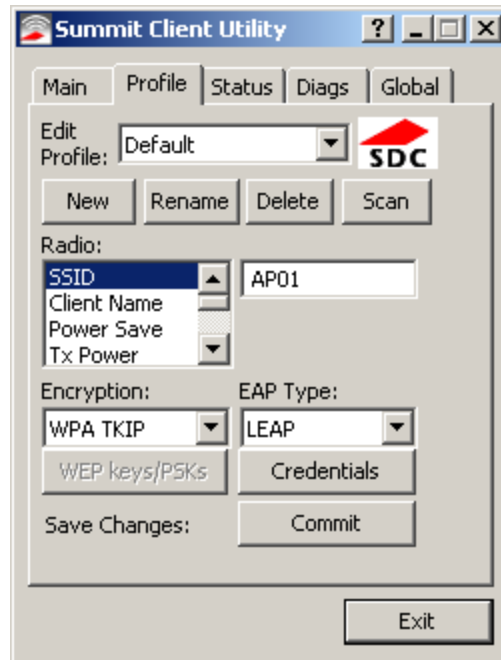

See [Sign-On vs. Stored Credentials](#) for information on entering credentials.

To use Stored Credentials, click on the **Credentials** button. No entries are necessary for Sign-On Credentials as the user will be prompted for the Username and Password when connecting to the network.

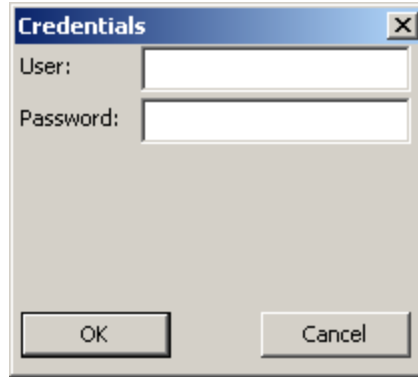

Enter the Domain\Username (if the Domain is required), otherwise enter the Username.

Enter the password.

Click **OK** then click the **Commit** button.

Ensure the correct Active Profile is selected on the [Main tab](#) and restart. The SCU Main tab shows the device is associated after the radio connects to the network.

EAP-FAST

To use EAP-FAST, make sure the following profile options are used.

- Enter the **SSID** of the Access Point assigned to this profile
- Set **EAP Type** to **EAP-FAST**
- Set **Encryption** to **WPA TKIP**
- Set **Auth Type** to **Open**

To use another encryption type, select WPA CCKM, WPA2 AES or WPA2 CCKM for encryption and complete other entries as detailed in this section.

The SCU supports EAP-FAST with automatic or manual PAC provisioning. With automatic PAC provisioning, the user credentials, whether entered on the saved credentials screen or the sign on screen, are sent to the RADIUS server. The RADIUS server must have auto provisioning enabled to send the PAC provisioning credentials to the Thor VM1.

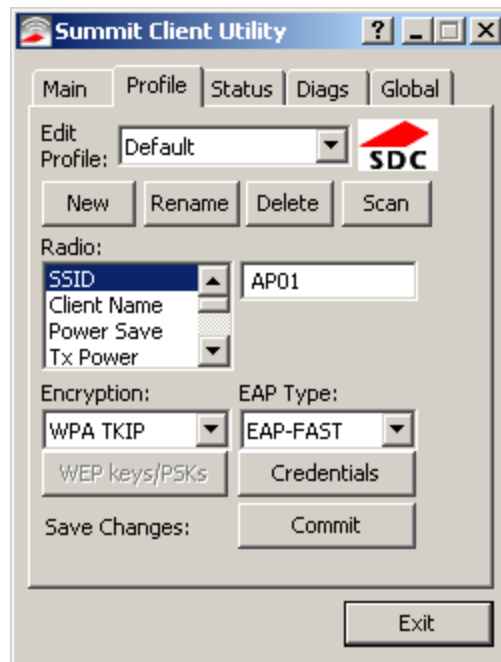

For automatic PAC provisioning, once a username/password is authenticated, the PAC information is stored on the Thor VM1. The same username/password must be used to authenticate each time. See the note below for more details.

For manual PAC provisioning, the PAC filename and Password must be entered.

See [Sign-On vs. Stored Credentials](#) for information on entering credentials.

The entries on the Credentials screen are determined by the type of credentials (stored or sign on) and the type of PAC provisioning (automatic or manual).

Click on the **Credentials** button.

To use Stored Credentials, click on the **Credentials** button. No entries are necessary for Sign-On Credentials with automatic PAC provisioning as the user will be prompted for the Username and Password when connecting to the network.

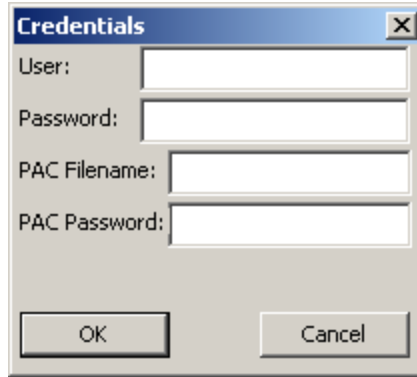

To use Sign-On credentials:

- Do not enter a User and Password as the user will be prompted for the Username and Password when connecting to the network.

To use Stored Credentials:

- Enter the Domain\Username (if the Domain is required), otherwise enter the Username.
- Enter the password.

To use Automatic PAC Provisioning:

- No additional entries are required.

To use manual PAC Provisioning:

- Enter the PAC Filename and PAC Password.
- The PAC file must be copied to the directory specified in the Certs Path global variable. The PAC file must not be read only.

Ensure the correct Active Profile is selected on the [Main tab](#) and restart. The SCU Main tab shows the device is associated after the radio connects to the network.

Note: When using Automatic PAC Provisioning, once authenticated, there is a file stored in the C:\Program Files\Summit\certs directory with the PAC credentials. If the username is changed, that file must be deleted. The filename is autoP.00.pac.

EAP-TLS

To use EAP-TLS, make sure the following profile options are used.

- Enter the **SSID** of the Access Point assigned to this profile
- Set **EAP Type** to **EAP-TLS**
- Set **Encryption** to **WPA TKIP**
- Set **Auth Type** to **Open**

To use another encryption type, select WPA CCKM, WPA2 AES or WPA2 CCKM for encryption and complete other entries as detailed in this section.

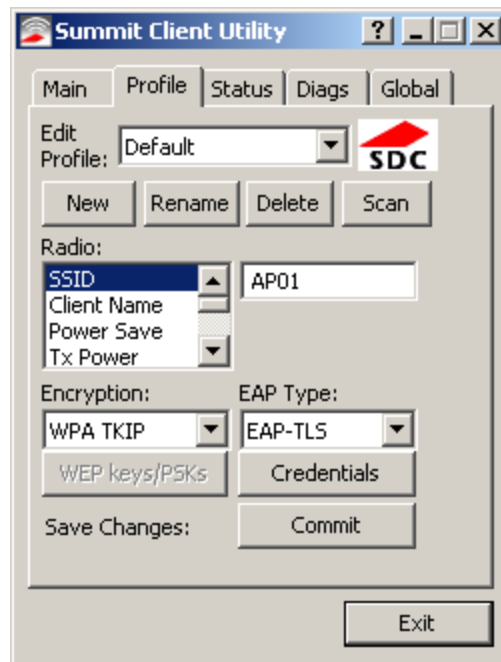

See [Sign-On vs. Stored Credentials](#) for information on entering credentials.

Click the **Credentials** button.

- No entries except the User Certificate Filename and the CA Certificate Filename are necessary for Sign-On Credentials as the user will be prompted for the User Name when connecting to the network.
- For Stored Credentials, User Certificate Filename and the CA Certificate Filename must be entered.

Enter these items as directed below.

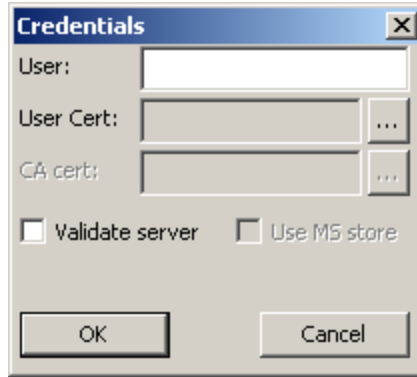

Enter the Domain\Username (if the Domain is required), otherwise enter the Username.

Select a user certificate from the Windows certificate store. Use the **Browse** button to locate the User Cert from the certificate store. Highlight the desired certificate and press the **Select** button. The name of the certificate is displayed in the User Cert box.

Some versions of the SCU require a User Cert password. If this entry field is present, enter the password for the user certificate in the User Cert pwd box.

If there are no user certificates in the Windows certificate store, follow these instructions to [generate](#) and [install](#) the user certificate.

See [Windows Certificate Store vs. Certs Path](#) for more information on CA certificate storage.

Check the **Validate server** checkbox.

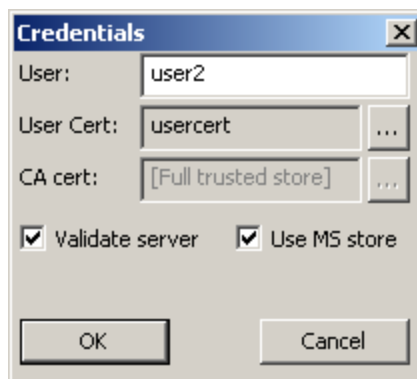

If using the Windows certificate store:

- Check the **Use MS store** checkbox. The default is to use the Full Trusted Store.
- To select an individual certificate, click on the **Browse** button.
- Uncheck the **Use full trusted store** checkbox.
- Select the desired certificate and click **Select**. You are returned to the Credentials screen.

If using the Certs Path option:

- Leave the Use MS store box unchecked.
- Enter the certificate filename in the CA Cert textbox.

Click **OK** then click **Commit**.

The Thor VM1 should be authenticating the server certificate and using EAP-TLS for the user authentication.

Ensure the correct Active Profile is selected on the [Main tab](#) and restart. The SCU Main tab shows the device is associated after the radio connects to the network.

See [Certificates](#) for information on generating a Root CA certificate or a User certificate.

Note: The date must be properly set on the device to authenticate a certificate.

WPA PSK

To connect using WPA/PSK, make sure the following profile options are used:

- Enter the **SSID** of the Access Point assigned to this profile
- Set **EAP Type** to **None**
- Set **Encryption** to **WPA PSK** or **WPA2 PSK**
- Set **Auth Type** to **Open**

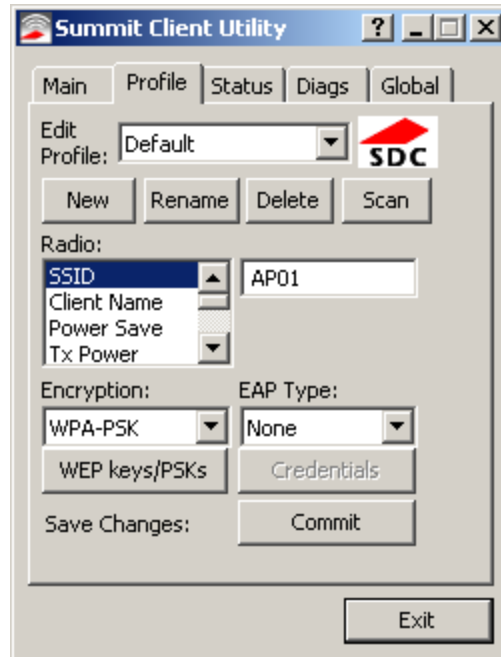

Click the **WEP keys/PSKs** button.

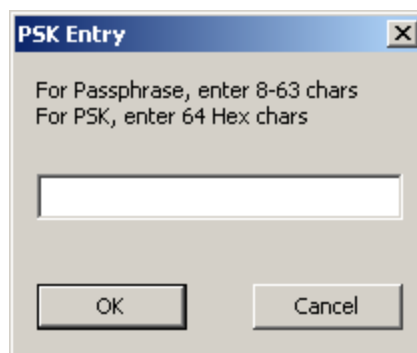

This value can be 64 hex characters or an 8 to 63 byte ASCII value. Enter the key and click **OK**.

Once configured, click the **Commit** button.

Ensure the correct Active Profile is selected on the [Main tab](#) and restart. The SCU Main tab shows the device is associated after the radio connects to the network.

Certificates

Note: Please refer to the Security Primer to prepare the Authentication Server and Access Point for communication.

Note: It is important that all dates are correct on the Thor VM1 and host computers when using any type of certificate. Certificates are date sensitive and if the date is not correct authentication will fail.



If using the Windows Certificate Store, the Windows Account must have a password. The password cannot be left blank. The Summit Client Utility uses the Windows user account credentials to access the Certificate Store. The Windows user account credentials need not be the same as the [wireless credentials](#) entered in the Summit Client Utility.

Quick Start

Root Certificates are necessary for EAP-TLS, PEAP/GTC and PEAP/MSCHAP.

1. [Generate a Root CA Certificate](#) either from the Thor VM1 or using a PC.
2. If a PC was used to request the certificate, copy the certificate to the Thor VM1.
3. [Install the Root CA Certificate](#).

User Certificates are necessary for EAP-TLS

1. [Generate a User Certificate](#) either from the Thor VM1 or using a PC.
2. If a PC was used to request the certificate, copy the certificate to the Thor VM1.
3. [Install the User Certificate](#).

Generating a Root CA Certificate

Note: It is important that all dates are correct on the Thor VM1 and host computers when using any type of certificate. Certificates are date sensitive and if the date is not correct authentication will fail.

The easiest way to get the root CA certificate is to use a browser on a PC or the Thor VM1 to navigate to the Certificate Authority. To request the root CA certificate, open a browser to

<http://<CA IP address>/certsrv>.

Sign into the CA with any valid username and password.

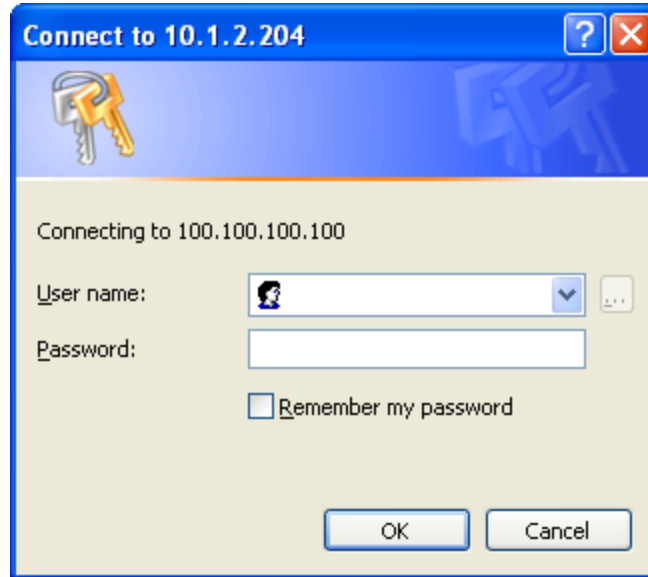

Welcome

Use this Web site to request a certificate for your Web browser, e-mail client, or other program. By using a certificate, you can verify your identity to people you communicate with over the Web, sign and encrypt messages, and, depending upon the type of certificate you request, perform other security tasks.

You can also use this Web site to download a certificate authority (CA) certificate, certificate chain, or certificate revocation list (CRL), or to view the status of a pending request.

For more information about Certificate Services, see [Certificate Services Documentation](#).

Select a task:

[Request a certificate](#)

[View the status of a pending certificate request](#)

[Download a CA certificate, certificate chain, or CRL](#)

Click the **Download a CA certificate, certificate chain or CRL** link.

Make sure the correct root CA certificate is selected in the list box.

Download a CA Certificate, Certificate Chain, or CRL

To trust certificates issued from this certification authority, [install this CA certificate chain](#).

To download a CA certificate, certificate chain, or CRL, select the certificate and encoding method.

CA certificate:

A dropdown menu with a blue header containing the text "Current". The menu is currently open, showing the selected item.

Encoding method:

- DER
- Base 64

[Download CA certificate](#)

[Download CA certificate chain](#)

[Download latest base CRL](#)

[Download latest delta CRL](#)

Click the **DER** button.

To download the CA certificate, click on the **Download CA certificate** link.

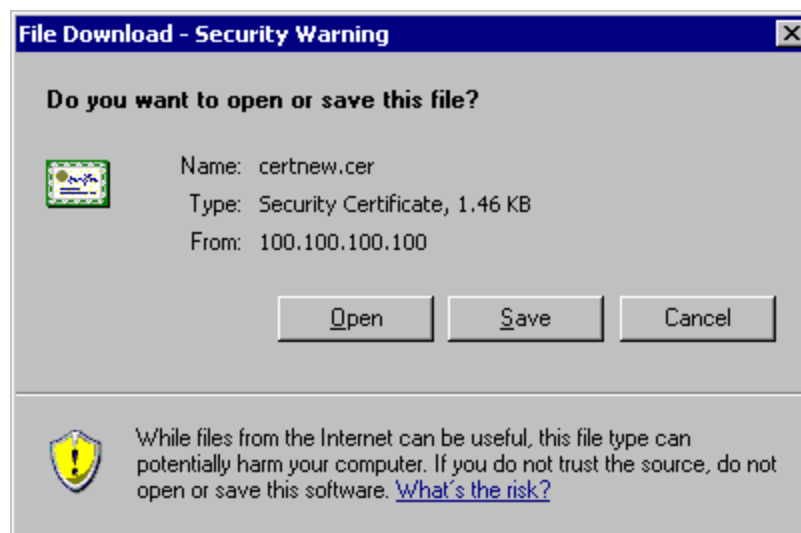

Click the **Save** button and save the certificate. Make sure to keep track of the name and location of the certificate. [Install](#) the certificate on the Thor VM1.

Installing a Root CA Certificate

Note: This section is only if the Windows certificate store is used. If the certificate store is not used, copy the certificate to the C:\Program Files\Summit\certs folder or other path specified in the Summit Certs global parameter.

Copy the certificate file to the Thor VM1. The certificate file has a .CER extension. Locate the file and double-tap on it. If presented with a security warning, confirm that you want to open the file.

Troubleshooting: If the Certificate Wizard does not start automatically when you double-tap the certificate .CER file:

1. Select **Start > Run** and type **certmgr.msc** in the text box and tap **OK**.
2. In the left pane, right-click **Trusted Root Certificate Authorities** and select **All Tasks > Import**.
3. The Certificate Import Wizard starts.
4. Tap **Next** and use the **Browse...** button to locate the Root certificate copied to the Thor VM1 then tap **Open**.
5. The certificate filename and path are displayed. Tap **Next**.

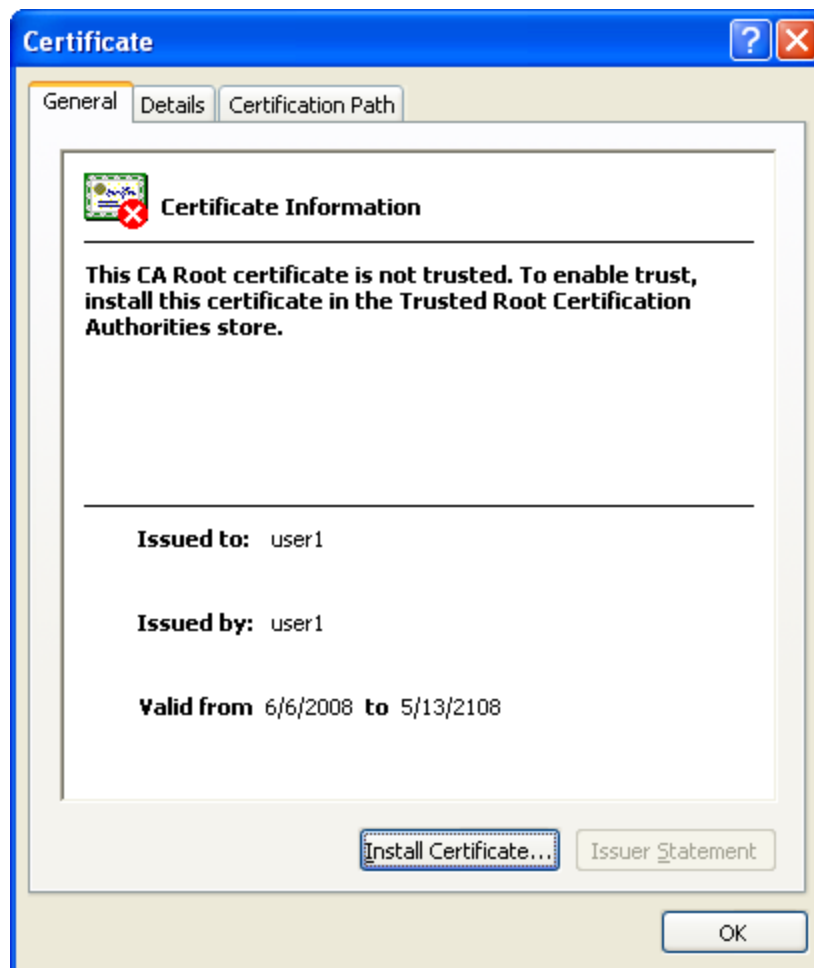

Tap the **Install Certificate** button.

The certificate import wizard starts. Tap **Next**.

Allow Windows to automatically select the certificate store.

Tap **Next** and **Finish**.

An import successful message is displayed.

Generating a User Certificate

The easiest way to get the user certificate is to use the browser on the Thor VM1 or a PC to navigate to the Certificate Authority. To request the user certificate, open a browser to

<http://<CA IP address>/certsrv>.

Sign into the CA with the username and password of the person who will be logging into the mobile device.



This process saves a user certificate file. There is no separate private key file as used on Windows CE devices.

Welcome

Use this Web site to request a certificate for your Web browser, e-mail client, or other program. By using a certificate, you can verify your identity to people you communicate with over the Web, sign and encrypt messages, and, depending upon the type of certificate you request, perform other security tasks.

You can also use this Web site to download a certificate authority (CA) certificate, certificate chain, or certificate revocation list (CRL), or to view the status of a pending request.

For more information about Certificate Services, see [Certificate Services Documentation](#).

Select a task:

[Request a certificate](#)

[View the status of a pending certificate request](#)

[Download a CA certificate, certificate chain, or CRL](#)

Click the **Request a certificate** link.

Request a Certificate

Select the certificate type:

[User Certificate](#)

Or, submit an [advanced certificate request](#).

Click on the **User Certificate** link.

User Certificate - Identifying Information

No further identifying information is required. To complete your certificate, press submit:

[More Options >>](#)

Click on the **Submit** button. if there is a message box asking if you want to confirm the request, click **Yes**.
The User Certificate is issued.

Certificate Issued

The certificate you requested was issued to you.



[Install this certificate](#)

Install the user certificate on the requesting computer by clicking the **Install this certificate** link.
If the requesting computer is the Thor VM1, then the process is finished. otherwise, export the certificate as described below.

Exporting a User Certificate

Select **Tools > Internet Options > Content** and click the **Certificates** button.

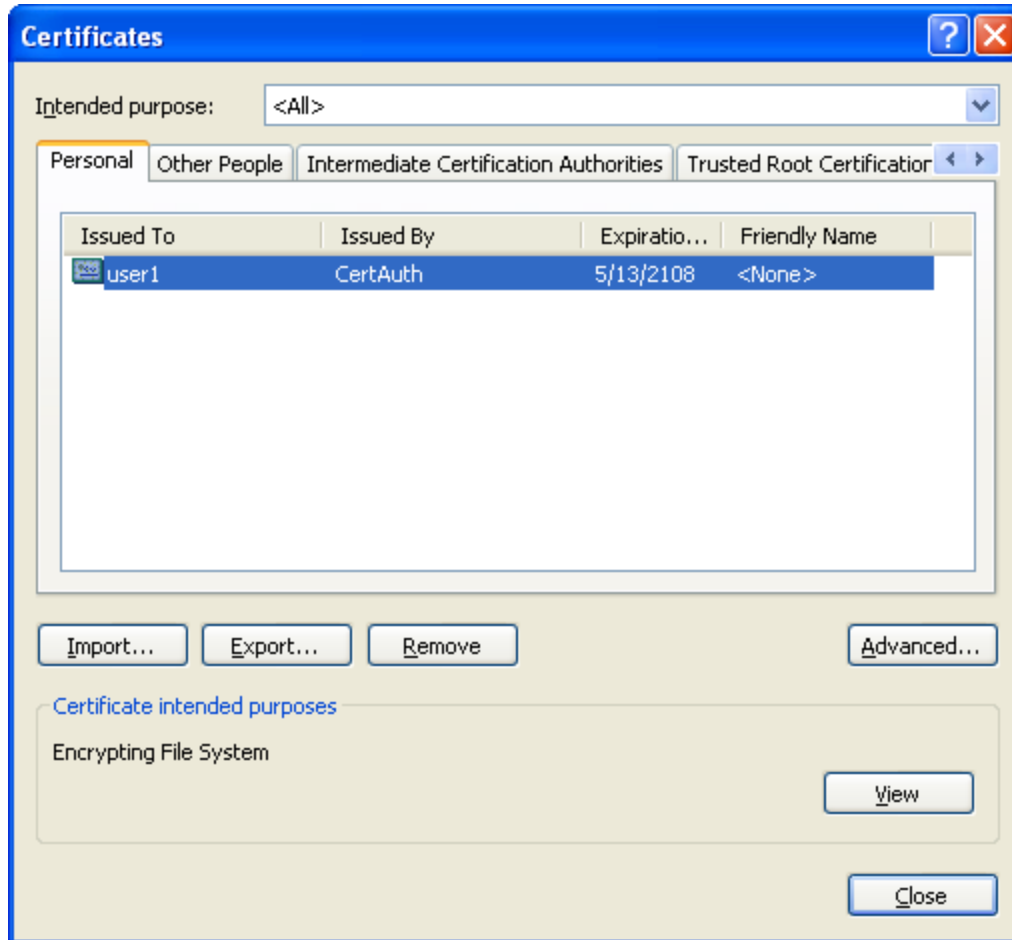

Make sure the **Personal** tab is selected. Highlight the certificate and click the **Export** button.

The Certificate Export Wizard is started

Select **Yes, export the private key** and click Next.

Do you want to export the private key with the certificate?

- Yes, export the private key
- No, do not export the private key

Uncheck **Enable strong protection** and check **Next**.
The certificate type must be PKCS #12 (.PFX).

- Personal Information Exchange - PKCS #12 (.PFX)
 - Include all certificates in the certification path if possible
 - Enable strong protection (requires IE 5.0, NT 4.0 SP4 or above)
 - Delete the private key if the export is successful

When the private key is exported, you must enter the password, confirm the password and click **Next**. Be sure to remember the password as it is needed when installing the certificate.

Type and confirm a password.

Password:

Confirm password:

Supply the file name for the certificate. Use the **Browse** button to select the folder where you wish to store the certificate. The certificate is saved with a .PFX extension.

File name:

Click Finish. and OK to close the Successful Export message.

Locate the User Certificate in the specified location. Copy to the Thor VM1. [Install](#) the User certificate.

Installing a User Certificate

After [generating](#) and [exporting](#) the user certificate, copy it from the PC to the Thor VM1. Copy the certificate to a location on the Thor VM1.

Locate the certificate file (it has a .PFX extension) and double-click on it.

Troubleshooting: If the Certificate Wizard does not start automatically when you double-tap the certificate .PFX file:

1. Select **Start > Run** and type **certmgr.msc** in the text box and tap **OK**.
2. In the left pane, right-click **Personal** and select **All Tasks > Import**.
3. The Certificate Import Wizard starts.
4. Tap **Next** and use the **Browse...** button to locate the User certificate copied to the Thor VM1. If necessary, change the file type drop down list at the bottom of the explorer window from *.cer to *.pfx. After selecting the .PFX file, tap **Open**.
5. The certificate filename and path are displayed. Tap **Next**.
6. Follow the instructions that follow starting with the [prompt for password](#).

The certificate import wizard starts. Tap **Next**.

Confirm the certificate file name and location.

Tap **Next**.

You are prompted for the password that was assigned when the certificate was exported.

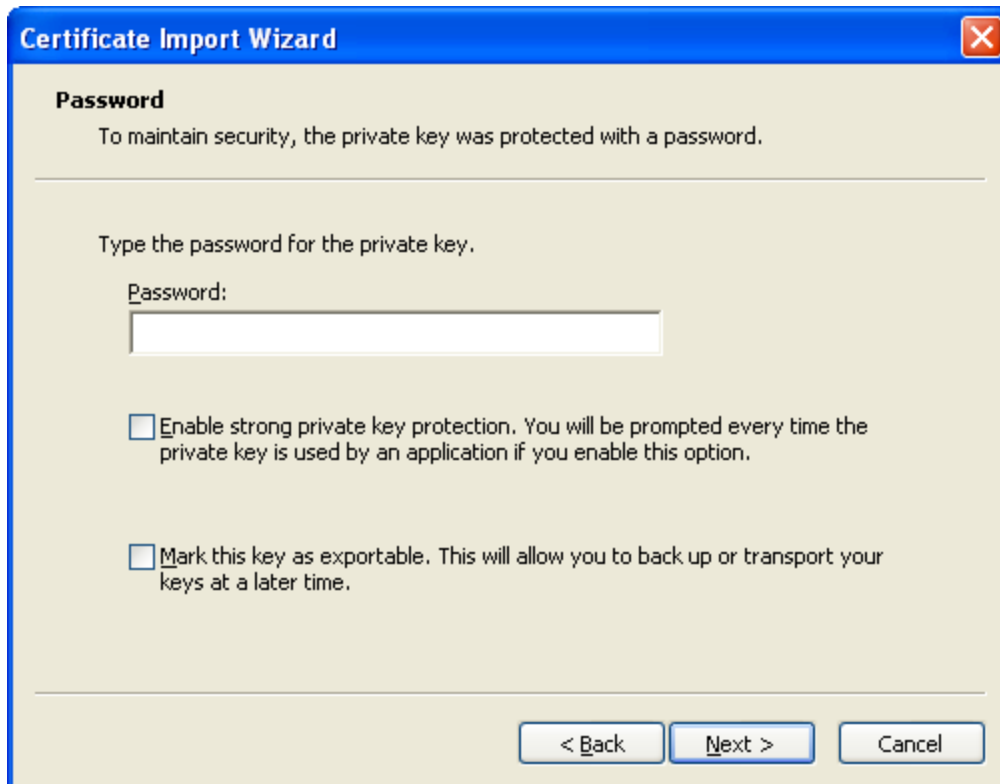

It is not necessary to select either of the checkboxes displayed above.

Enter the password and tap **Next**.

On the next screen, allow Windows to automatically select the certificate store, then click **Next** and **Finish**. An import successful message is displayed.

OneClick Internet

This section contains the User Manual for the customized version of WebToGo's OneClick Internet for the Honeywell Thor VM1.

OneClick Internet is installed by Honeywell on all Thor VM1s equipped with a WWAN radio. Available carriers and OneClick features may vary by device.

OneClick Internet provides:

- Internet connection management
- Email download
- SMS Management
- Contact management for SIM and Microsoft Outlook
- GPS Management

Since WebToGo OneClick Internet is preinstalled, it is present on the Windows Start Menu. A desktop icon is also provided.

	<p>Honeywell does not recommend using standby on the Thor VM1 while the WWAN connection is active. When exiting standby, a delay of one minute or more may occur as the WWAN radio reads firmware files and initializes before reconnecting. If this delay is acceptable to the user, standby may be enabled.</p> <p>When the One Click Internet utility is displayed on screen and the Thor VM1 enters standby, the touch screen may remain inactive for 10-15 seconds after the Thor VM1 resumes from standby.</p>
---	--

Preparing for Initial Use on the Thor VM1

Install SIM Card

If using a CDMA carrier such as Verizon, skip this step because a SIM card is not used.

[Install a SIM card](#) in the Thor VM1.

Load Firmware

While the OneClick Internet utility is preinstalled, it is necessary to load the GOBI radio firmware for your selected carrier such as AT&T, T-Mobile or Verizon.

Note: For carriers requiring a SIM card, the firmware may automatically be selected when a SIM card is installed in the Thor VM1.

Double-tap the OneClick Internet icon on the Thor VM1 desktop.



Tap the **Settings** button and select the **Firmware** tab. Select the firmware for your carrier from the list and tap **Change**.

For more details, see [OneClick Internet Connection Manager](#) and the [Firmware tab](#).

Activation

This step is only necessary for Verizon.

You need the IMEI number for the Thor VM1 when you contact Verizon prior to activating service on the Thor VM1. The IMEI number can be found on the [Settings > Info tab](#).

The activation screen is displayed automatically after the Verizon firmware is selected. If the activation screen is not automatically displayed, double-tap the **OneClick Internet** icon on the desktop. Select **Settings > General** tab and tap the **Activate** button.



Make sure **Automated Activation** is selected and tap **Next**.



Tap **Next** to complete the activation.

Once the activation is completed, OneClick Internet may be minimized to the tray.

🔍 To verify your settings, tap on the OneClick Internet icon in the system tray.

Tap **Settings**.

Tap the **Network** tab.

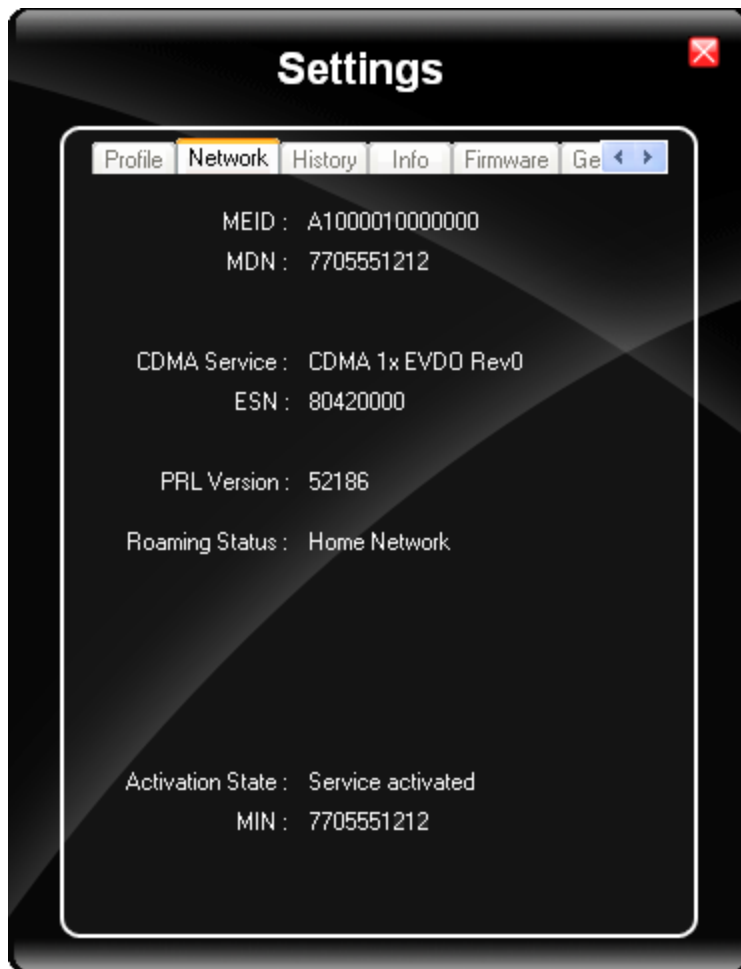

This screen contains the settings including the telephone number from the provider, in this case Verizon.

Using OneClick Internet

If OneClick Internet is not loaded, double-tap the desktop icon to load it. If OneClick Internet is loaded but minimized to the system tray, tap the OneClick Internet icon in the system tray to maximize it.

How To: Connection Management

1. Launch the OneClick Internet Connection Manager and wait until the status icon is blue indicating ready.
2. If there is a problem, verify the SIM card is installed (AT&T, T-Mobile only), the proper firmware has been loaded, etc.
3. If PIN security is used, a popup window prompts for the SIM PIN.
4. Create a connection profile on the **Settings** menu.
5. Tap the **Connect** button.



The signal strength is indicated as well as the name of the mobile network you are using and the status of the WWAN device. Tap the **Disconnect** button to end the session.



Menu Buttons

Radio Button

 The Radio button allows you to switch the WWAN radio on and off to save power or to disable the radio in instances where it is not desired (such as during airplane travel).

When the radio is switched off, the button is red. When on, it is green. If the radio is disabled by a hardware switch or if the device is not available, the button is disabled and is light gray/white.

Statistics Button

 The Statistics area provides advanced information about the connection. Values displayed are approximate.

Tap the **Statistics** button to enable the statistics viewing area, which is below the main area. When the statistics are displayed, tapping the **Statistics** button again hides the statistics viewing area.

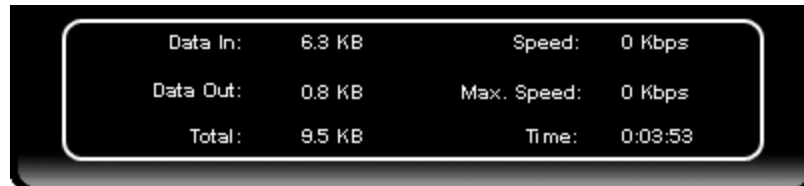

Data In:	6.3 KB	Speed:	0 Kbps
Data Out:	0.8 KB	Max. Speed:	0 Kbps
Total:	9.5 KB	Time:	0:03:53

Data In:	The amount of data received during the current connection.
Data Out:	The amount of data sent during the current connection.
Total:	The total amount of data transferred during the current connection.
Speed:	The current data transfer rate.
Max. Speed:	The maximum data transfer rate during this connection.
Time:	The duration of the current connection.

Update Button

 One Click Internet provides a built-in online update functionality that allows for an automatic update of OneClick Internet application, device drivers, and APN database.

Honeywell **DOES NOT** recommend using this option. Contact [Technical Assistance](#) for information on upgrading to another version of OneClick Internet.

The update is triggered by pressing the update button. The application will check the WebToGo server, if updates are available, and offer them for download if suitable.

In order to start the update, select a file from the list of available updates and tap **OK**.

Help Button

 OneClick Internet includes online help that can be accessed by tapping the Help button.

Settings Button



Access the Settings menu by tapping the Settings button on the main window.

The following tabs are available:

- Profile
- Network
- History
- PIN
- Info
- Firmware
- General

Profile Tab





The screenshot shows a 'Settings' window with a 'Profile' tab selected. The window has a title bar with a red close button. Below the title bar is a tabbed interface with 'Profile', 'Network', 'History', 'PIN', 'Info', and 'Firmw' tabs. The 'Profile' tab is active and contains the following fields and options:

- Profile Name: [Text input field]
- APN: [Text input field]
- Username: [Text input field]
- Password: [Text input field]
- Use automatic DNS-settings
- Use Proxy Server
- Proxy: [Text input field]
- Port: [Text input field]

On the right side of the form, there is a vertical stack of four icons: a document with a plus sign, a document with a minus sign, a document with an 'X', and a document with a plus sign. At the bottom of the form is a 'Set Profile' button.

Create a connection profile to store connection information. Once a profile has been created, its name appears in the drop down Profiles list, which replaces the Profile Name textbox in the illustration above.

Buttons

Button	Description
	Create a new profile. When this option is selected, the Profile Name is a text box. Enter a name for the profile as well as other connection specific configuration. When finished, tap the Save button to save the new profile.
	Edit a current profile. Select a profile from the Profiles list and tap this button to edit the profile parameters. When finished, tap the Save button to save the profile changes.
	Delete a profile. Select a profile from the Profiles list and tap this button to delete the profile
	Save a profile. Save a new profile or save changes made when editing a profile.
	Set Profile. Select a profile from the Profiles list and tap this button to make it the active profile used for connection.

Parameters

Label	Description
Profile Name	Profile name - Assign a unique name for each profile.
APN	Access Point Name of the network operator. Contact your network operator for more information When you are using a CDMA network, the APN field does not appear.
Username	Username. Contact your network operator for more information
Password	Password. Contact your network operator for more information
DNS	Domain Name Server. Contact your network operator for more information. When Use Automatic DNS-settings is selected, no additional DNS entries are required. Otherwise, enter the DNS addresses.
Proxy Settings	Proxy Settings for your network. Contact your network operator for more information. When Use Proxy Server is selected, no additional proxy entries are required. Otherwise, enter the Proxy and the Port.

Network Tab

The appearance of the network tab depends on the type of firmware selected.

Network with SIM Card

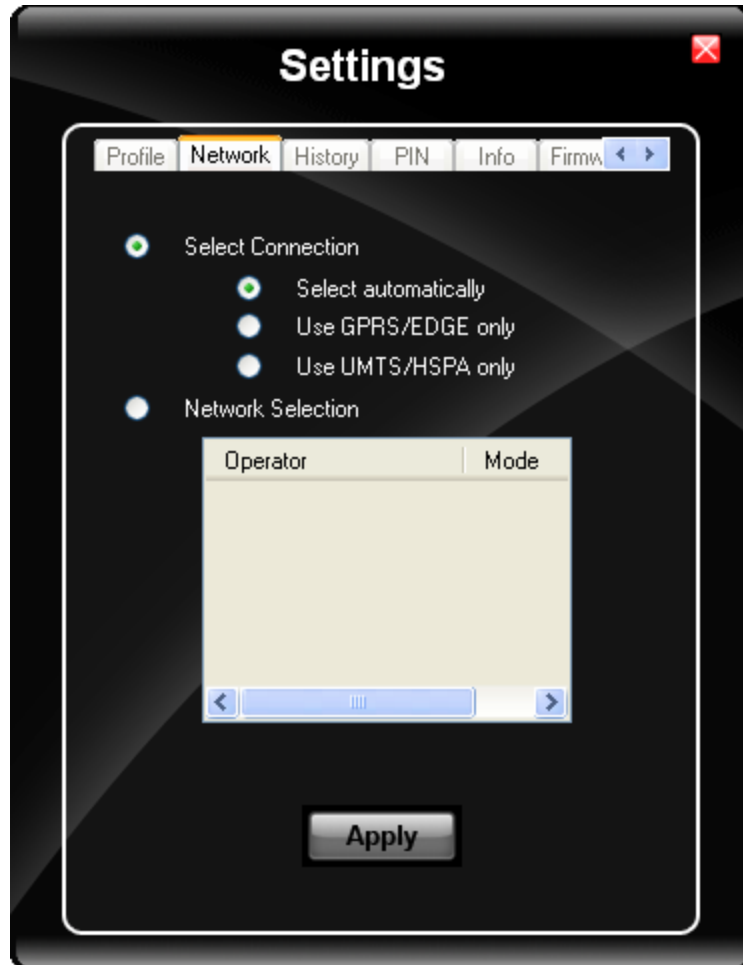

Select Connection

Label	Description
Select automatically	Selects the best suited network automatically
Use GPRS/EDGE only	Use only GPRS/EDGE for a connection
Use UMTS/HSPA only	Use only UMTS/HSPA for a connection.

Select and tap **Apply**. A "Network changed successfully" message is displayed.

Close the tab and view the signal strength icon in the main window. Once the signal strength is displayed, you can establish a connection.

Select Network

Use this option to select from available networks.

Note: When you are registered to a CDMA network, you cannot select the network. "All CDMA network" is shown instead.

Note: The network list only appears if the connection setting is **Only use GPRS** or **Only use UMTS/HSPA**.

Select the network and tap on the register button. If the change is successful you will see the message "Network changed successfully".

This item is useful when traveling . Automatic mode selects the preferred network of your network operator.

If enabled, Network Selection displays a list of network options.

1. Automatic Selection
2. Retrieving Networks...

The currently registered network is marked.

CDMA Network

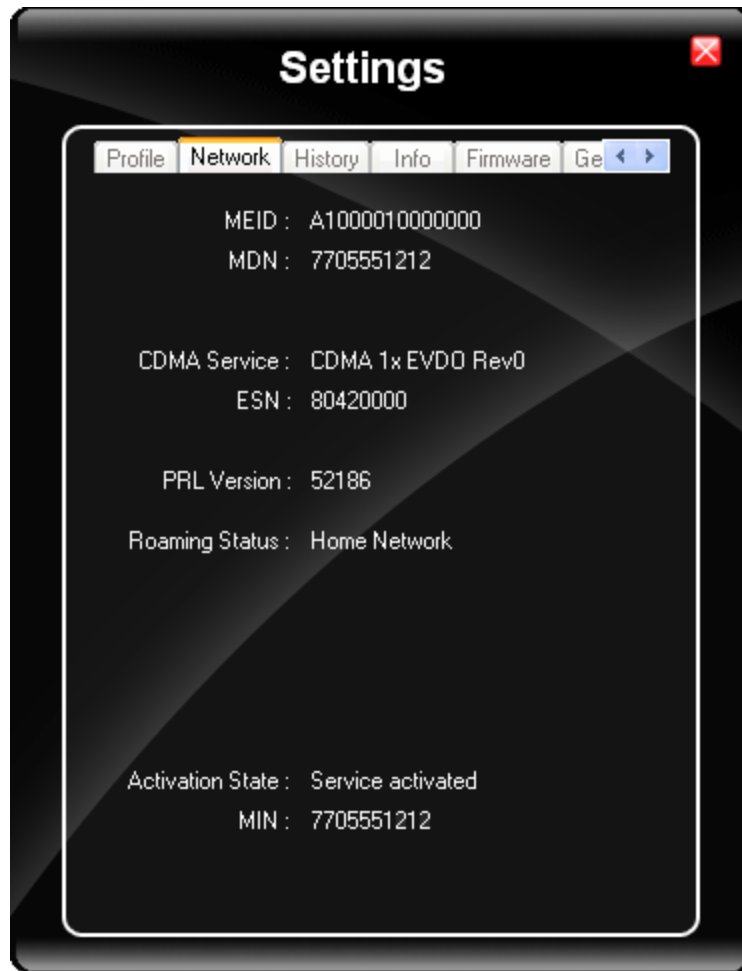

Information on the CDMA network is displayed. There are no editable parameters on this screen.

History Tab



The history shows the data volume transferred in a specified time frame. Select the **From** and **To** dates to see the data volume sent/received in the specified period. Tap **Reset** to reset the counter.

PIN Tab

You can Activate/Deactivate the PIN or Change the PIN.

Activate/Deactivate PIN

This tab is only displayed when a firmware is loaded that requires a SIM card (such as AT&T or T-Mobile).

By default, you have to enter the PIN each time you start WebToGo OneClick Internet using a modem card. Deactivate the PIN to avoid entering the PIN each time.

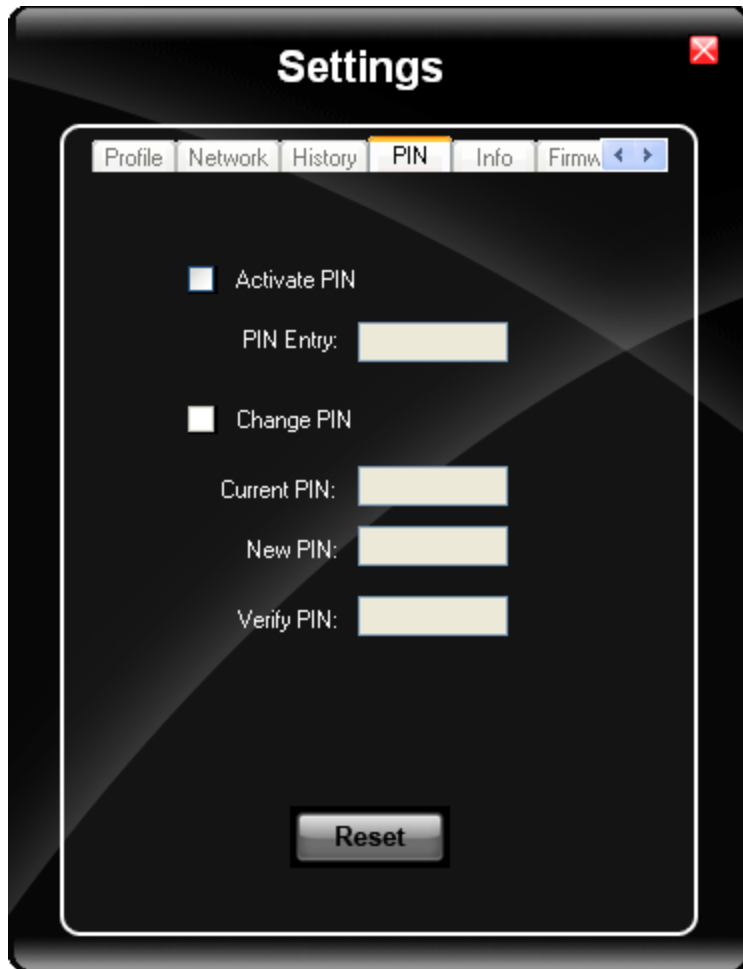

Change PIN

This dialog lets you change your PIN.

Label	Description
Current PIN	Enter the current PIN.
New PIN	Enter the new PIN.
Verify PIN	Verify the new PIN by entering it again.

Info Tab



This tab displays SIM card, modem and system Information.

Firmware Tab



OneClick Internet selects the correct Firmware matching your operator automatically, if a special firmware for your operator is available and a SIM card is inserted. If no specific firmware for your operator is available, generic firmware is selected. After a firmware has been selected, it appears as the **Current Profile**.

You can manually load your desired firmware. Select a new firmware manually by clicking the **Select New Profile** dropdown menu, selecting a firmware from the menu and tapping the **Change** button to load. To return to automatic firmware selection, choose **Automatic(UMTS)** in the dropdown menu.

Note: Switching between CDMA and UMTS firmware is not done automatically. You must select CDMA firmware manually to connect to CDMA networks. If you want to return to UMTS networks, you must manually select UMTS firmware.

Activation on CDMA

When CDMA Firmware is selected, the activation of the modem on the CDMA network starts automatically. During the process of loading CDMA firmware, an activation window pop up allowing a choice between **Manual Activation** and **Automated Activation**.

Label	Description
Manual Activation	Enter the requested items as direct by a representative from your carrier.
Automatic Activation	Use your modem to start an automated activation session

If you cancel the activation or if it fails, you can also start the activation manually by pressing the **Activate** button on the **General** tab.

General Tab

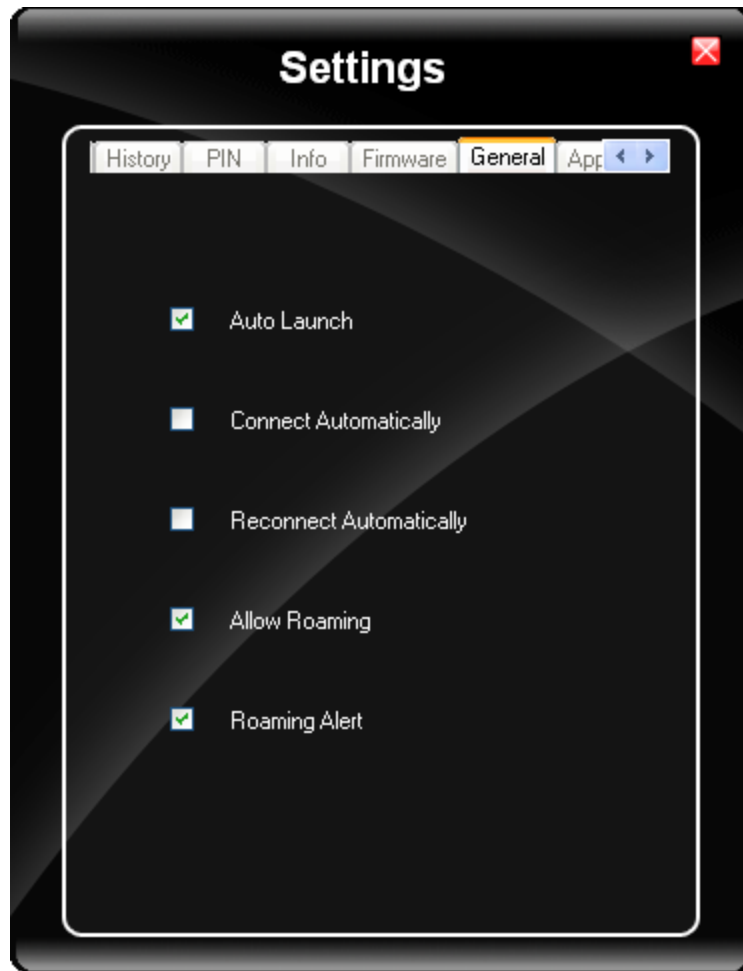

Label	Description
Auto Launch	When selected OneClick Internet launches automatically when the user starts the Thor VM1 and logs in.
Connect Automatically	When selected OneClick Internet automatically connects on start-up.
Reconnect Automatically	When selected OneClick Internet reconnects automatically when the Thor VM1 returns from standby or hibernate.
Allow roaming	When selected OneClick Internet allows connections in foreign networks. Use care when enabling roaming to avoid roaming charges.
Roaming Alert	When selected OneClick Internet displays an alert when roaming.
Gobi NDIS Auto Connect	When selected OneClick Internet connects automatically after powering up the operating system and before the user logs in.

Application Tab

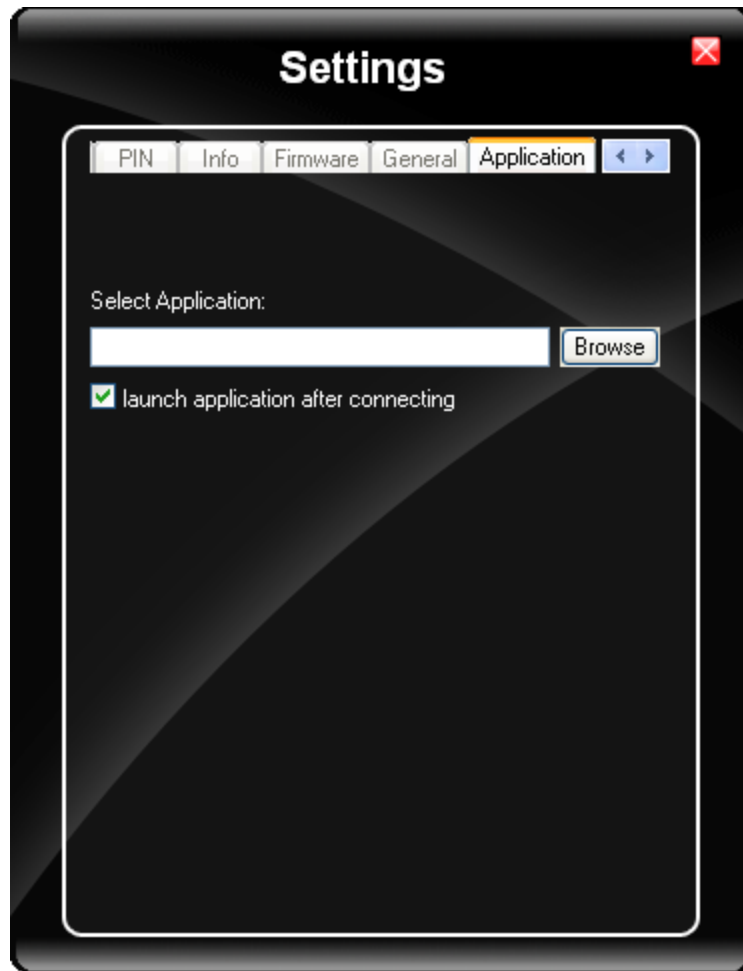





Use the **Application** tab to specify any application to launch automatically once the Internet connection is established. Use the Browse button to locate the desired application.

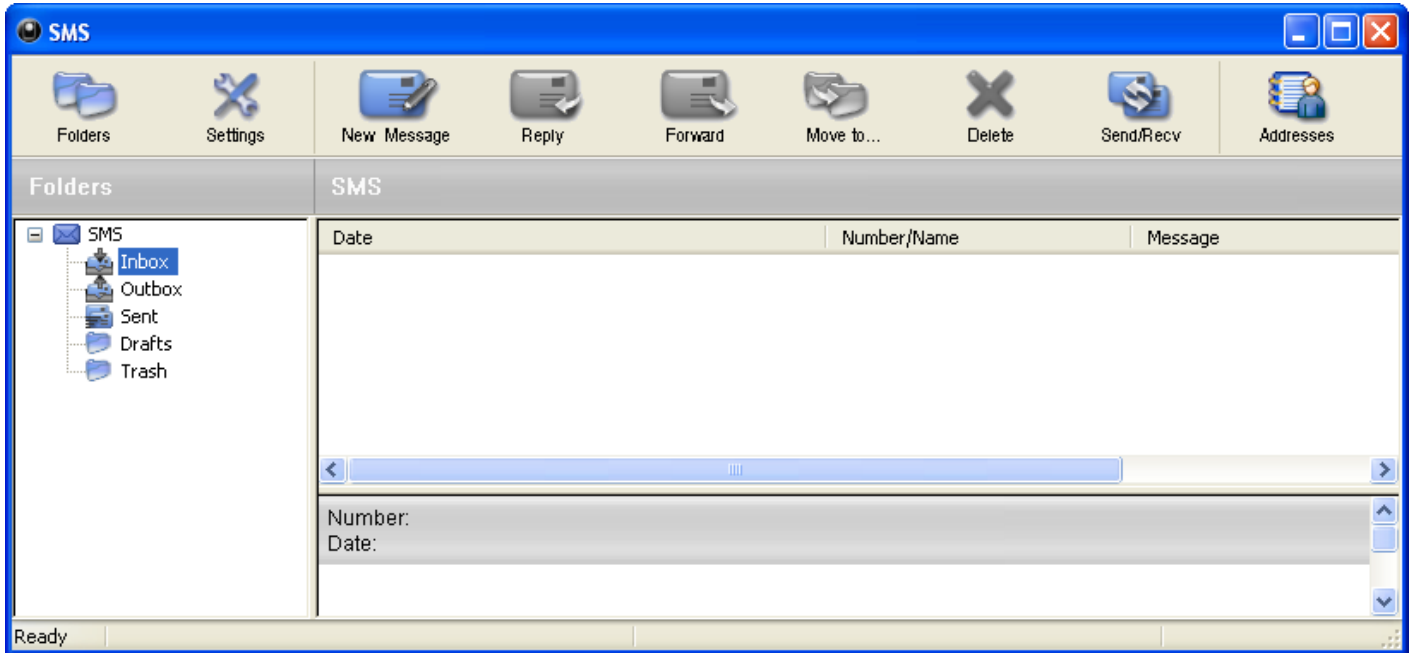



Application Buttons

SMS



The SMS Center window is split into menu bar, folder view, folder content and preview window. To manage your short messages you may:

Button	Description
 Folders	Manage SMS folders
 Settings	Change SMS settings
 New Message	Create new SMS/MMS messages
 Reply	Reply to SMS
 Forward	Forward SMS

Button	Description
	Move SMS to a folder
	Delete SMS
	Send and receive SMS/MMS (if supported)
	Manage phone book contacts on SIM and in Email client.

Folder

By using this menu, you may change the folder structure of the SMS Center:

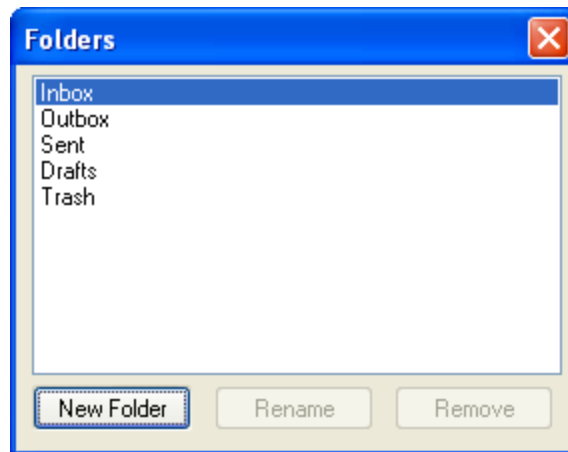

Button	Description
New Folder	Creates a new folder, name has to be unique
Rename	Renames an existing folder
Remove	Removes an existing folder (including the messages)

Note: Predefined folders can't be deleted or modified.

Settings

The settings window lets you change the deletion mode. You may choose whether to delete an SMS from the SMS Center, from the SIM or decide whether this should be asked at all. You may also activate an alarm signal when a new SMS arrives.

New SMS

The "New Message" window is used to enter the SMS text. You may also enter texts by copy & paste from other applications. The status bar at the lower right corner indicates the length of the SMS for your convenience: the first number tells you how

many parts the SMS consists of (one part has max. 160 characters/unicode70), the second number counts down from 160/70 characters. The number in parenthesis () counts the total number of characters. The recipient for your SMS has to be entered in the "To" field. This can be either entered by typing digits or by clicking the "To" button to select a recipient from the address book. Recipient addresses may be taken from the SIM address book or from your Email client's contact folder. Just select an address and click OK. To send the message click "Send/Receive".

Reply

Highlight a message to which you want to reply, e.g. in the inbox folder, then click the "Reply" button. The "New Message" window opens and the recipient address is already filled in the "To" field. Continue as before when sending a new message.

Forward

Highlight a SMS, which you want to forward. Click the "Forward" button. The "New Message" window opens, however the message text is already copied. Continue as before when sending a new message.

Move SMS...

Highlight the SMS to be moved and click the "Move SMS" button. A small window opens that lets you select the destination folder. Select the folder to which the message should be moved, then click "Move".

Delete

Highlight the SMS which you want to delete. Click "Delete" to remove the message.

Send/Receive

Messages will be sent and/or received by clicking on this button.

Addresses

Clicking this button opens the address book. You may add new contacts to your personal address book or you may change existing addresses, delete addresses or exchange them with your SIM card and your Email client application, or export the data set.

Buttons	Description
New Contact	Create new contact.
Modify	Modify a contact.
Delete	Delete contacts, mark one or more and press the button.
Copy	Synchronization with MS Outlook.
Export	To export addresses you may select between two export formats: <ul style="list-style-type: none">• CSV (comma separated text format, usually read by spread sheet applications)• VCard (business card format, used by MS Outlook and other applications)

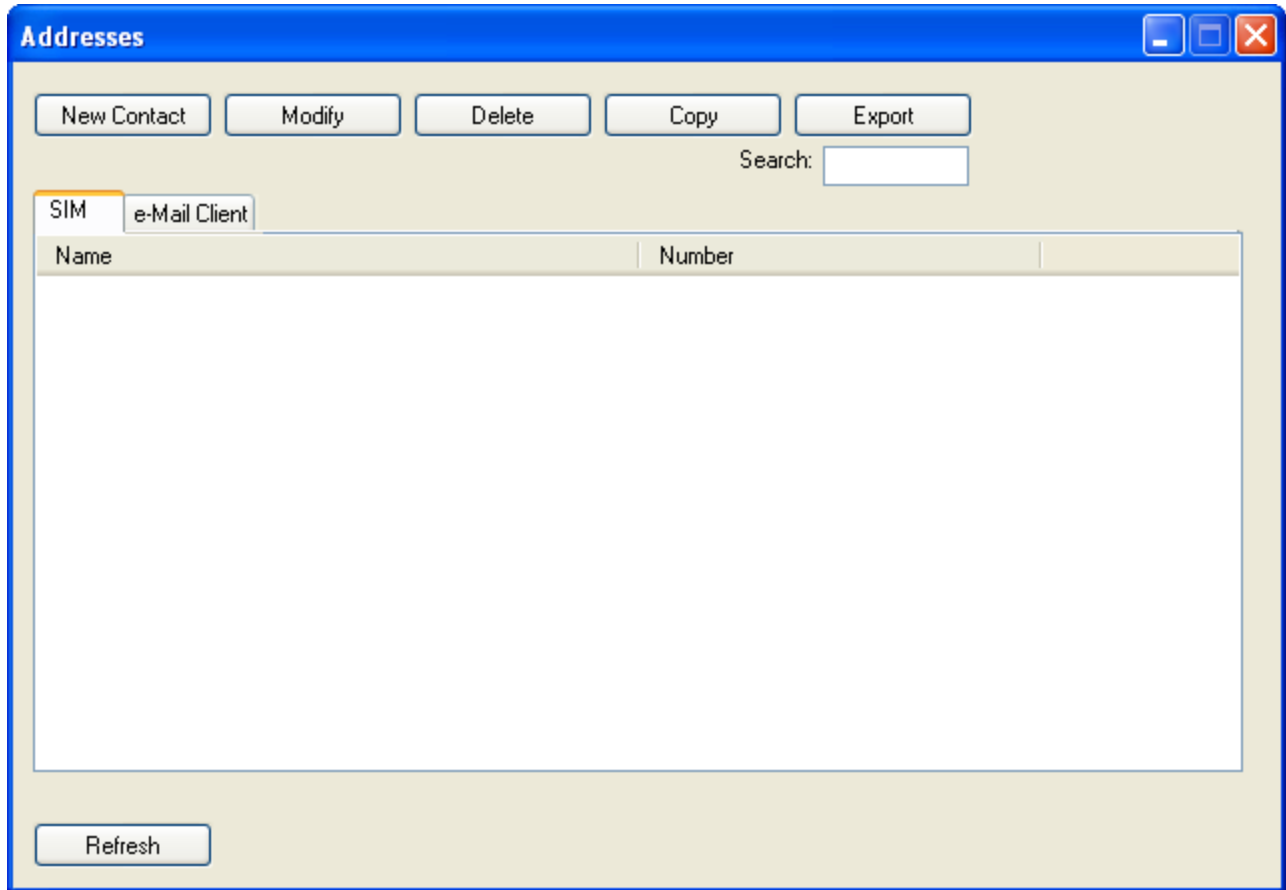

Web Browser

Clicking this button opens the Web Browser and allows the user to surf the Internet once the connection is established. The default browser is used, which is Internet Explorer by default on the Thor VM1.

Email

Clicking this button opens the Email application after the connection is established. The Email application is the default Email client set in the Control Panel (**Start > Control Panel > Internet Options > Programs** tab).

GPS

Tap the GPS button to open the GPS window. Press **Get GPS** to start the GPS. The rotating GPS button indicates the GPS is active.



After Latitude and Longitude Data are displayed, the user can tap **Track Me** to open Google Maps, showing their current location on a map.

Lat - Latitude - The location north or south of the equator in degrees.

Lon - Longitude: The angular distance from the Prime Meridian in degrees.

After Latitude and Longitude Data are displayed, the user can tap **Clipboard** and the latitude and longitude are copied to the clipboard cache. The data can be pasted into an email, document or other electronic media.

About

OneClick Internet allows the user to configure the WWAN connection by entering basic setup information. The network connection (service carrier) can be chosen based on the firmware loaded, GPS tracking can be enabled and SMS messaging can be configured.

Once configured, OneClick Internet allows the user to connect or disconnect from the mobile network.

System Requirements

OneClick Internet requires:

- Gobi 2000 3G Module (preinstalled by Honeywell)
- Gobi 2000 Driver package (loaded by Honeywell)

OneClick Internet for Gobi 2000 is compatible with

- Windows Embedded Standard 2009 on the Thor VM1

Supported Languages

OneClick Internet supports the following languages:

German, English, Spanish, French, Polish, Russian, Italian, simplified Chinese and traditional Chinese.

Note: This does not mean that the Thor VM1 has been localized for these languages.

Installing or Upgrading OneClick Internet

Note: You must use the Honeywell supplied version of OneClick Internet. Do not change versions unless instructed by your Honeywell representative.

One Click Internet is pre-installed before the Thor VM1 is shipped.

If you have an installed version of OneClick Internet and need to update to a newer version, you must uninstall the previous version first by selecting **Start | Control Panel** and select **Add or Remove Programs**. Select **OneClick Internet** and tap **Remove**. Follow the on screen instructions.

Note: OneClick Internet does not install the drivers for the Gobi 2000 devices. Device drivers are preloaded.

Installation

When you double-click the Installer file for OneClick Internet, it extracts the files to install.

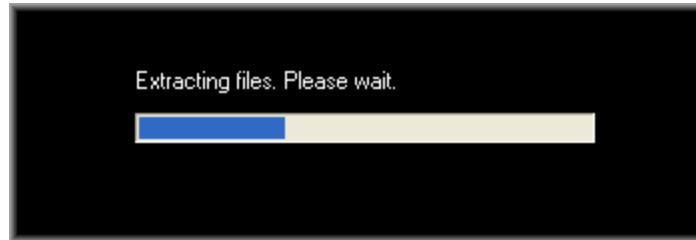

Next, select the application language. By default, the language of the OS is used (if available).

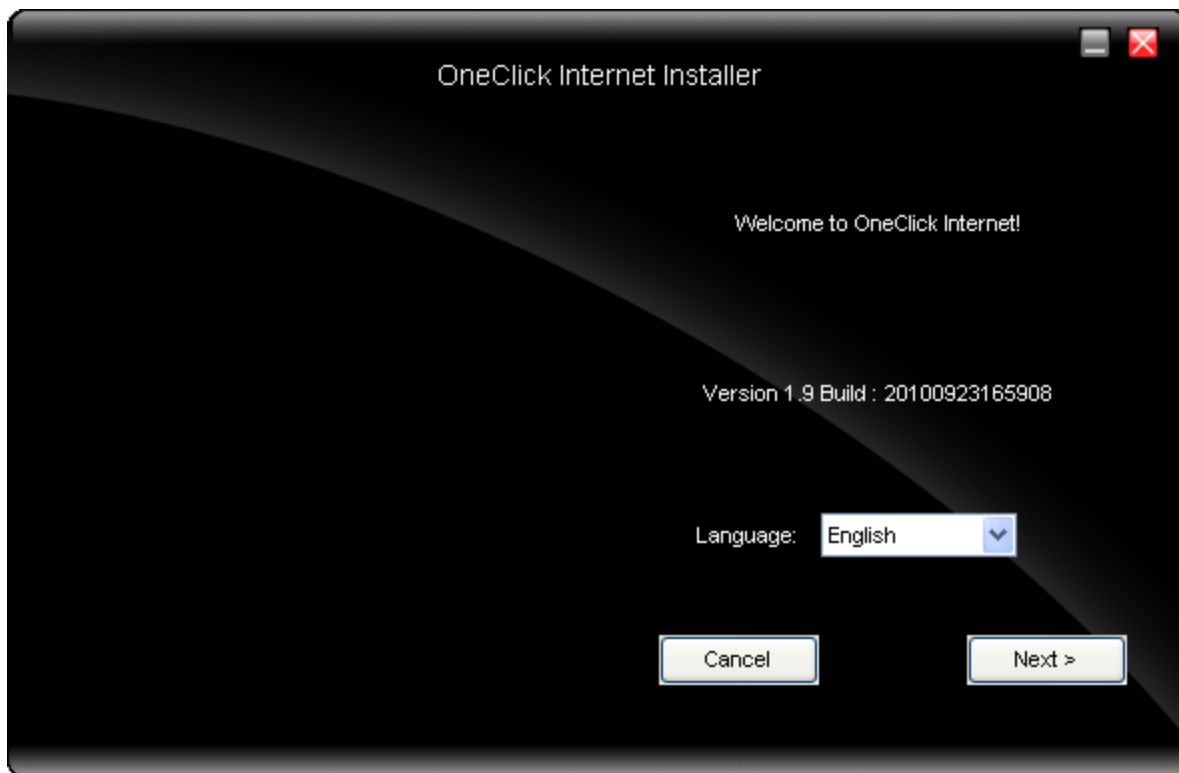

Review and accept the license agreement. Click **Accept**, if you agree. Otherwise please click **Reject** to cancel installation.

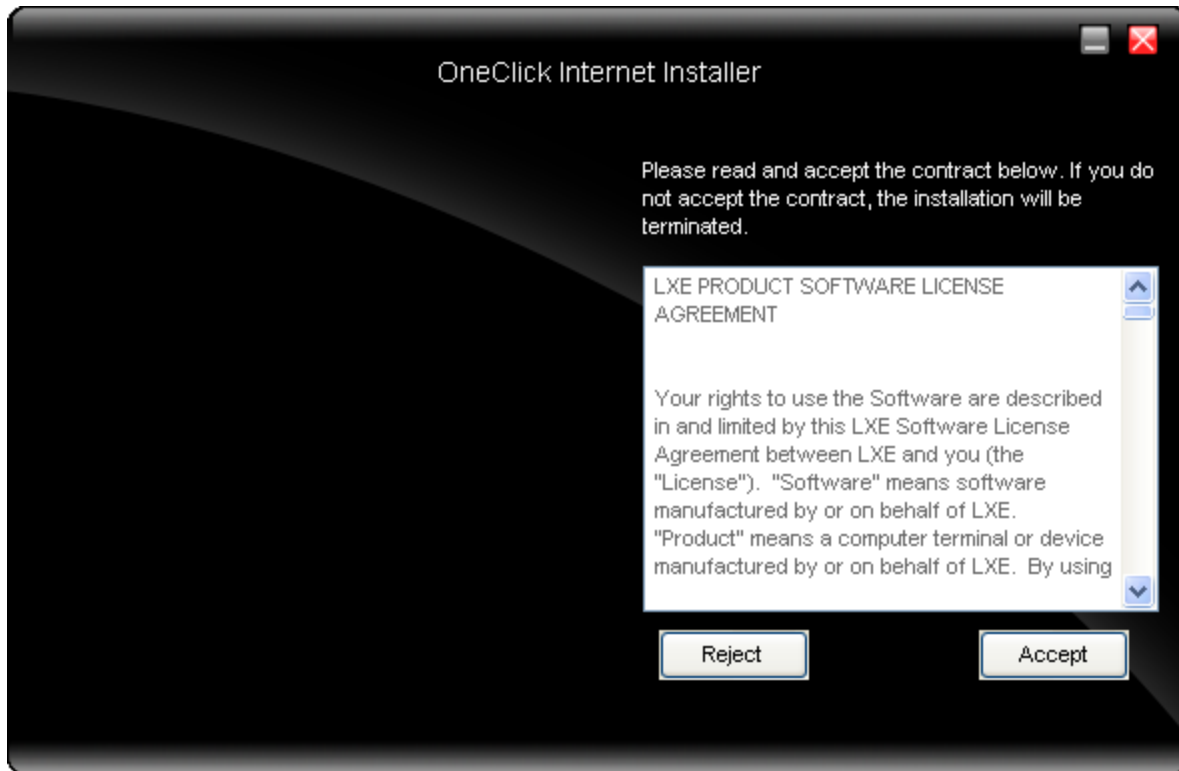

Next the installer asks for the installation directory. Use the **Browse** button to specify a location other than the default.

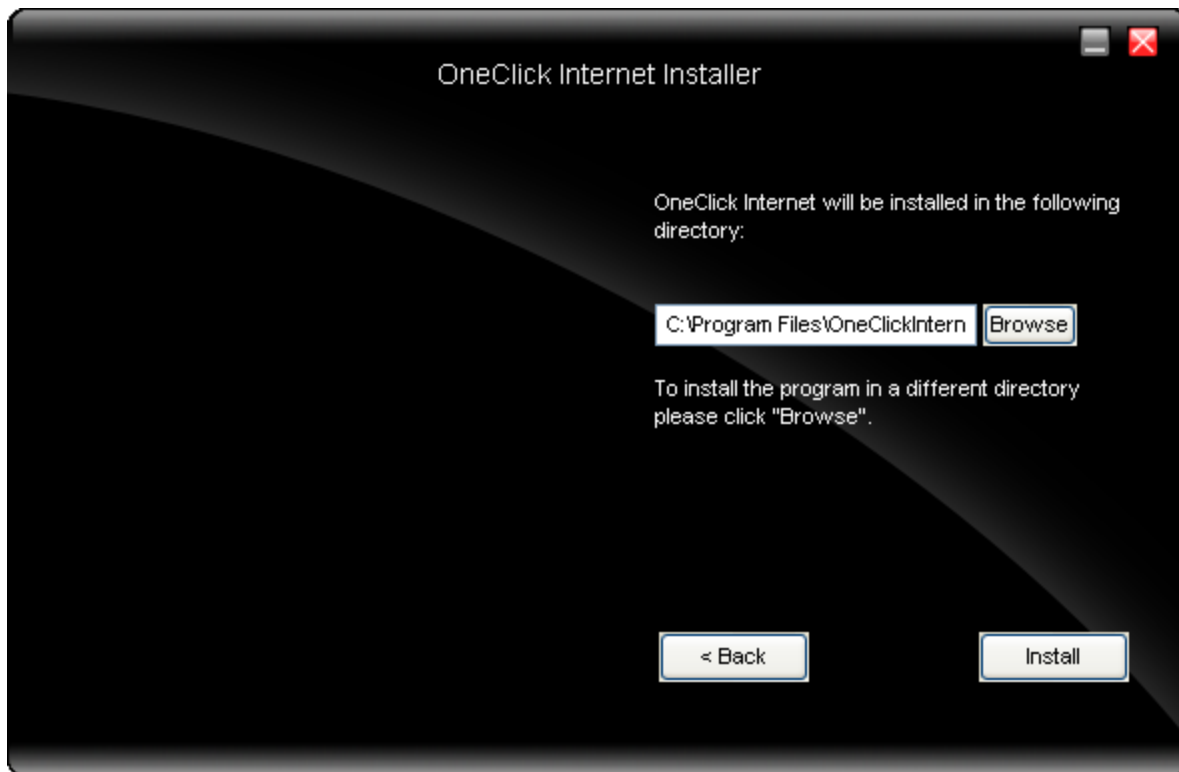

Installation process is indicated on screen. When completed, click the **Finish** button to exit the installer.



Start OneClick Internet from the Windows Program Menu or double-tap the desktop icon.

OneClick Internet Connection Manager

Launch OneClick Internet from the desktop icon or Windows Start Menu.

When OneClick Internet is active, a status icon appears in the system tray.











The main screen for OneClick Internet opens when the application is started. This screen displays basic information on the connection as well as access to more advanced features and details. From this screen you can connect to the Internet, send Emails, send short messages (SMS) and access the GPS.

General Windows controls for minimize and exit are located at the upper right of the screen.















Connection Management

Refer to the table below for descriptions of the items in the connection management area.

Icon	Description
	<p>Network signal strength Additionally the network name is displayed to the right of the icon. The more green bars, the stronger the signal.</p>
	<p>Connect / Cancel / Disconnect Tap this button to connect or disconnect. The color of this button also indicates the status of the connection:</p> <div style="display: flex; flex-direction: column; align-items: flex-start;"> <div style="display: flex; align-items: center; margin-bottom: 5px;">  <div style="margin-left: 10px;"> <p>The radio is disconnected. Tap the button to connect.</p> </div> </div> <div style="display: flex; align-items: center; margin-bottom: 5px;">  <div style="margin-left: 10px;"> <p>The radio is currently connecting.</p> </div> </div> <div style="display: flex; align-items: center;">  <div style="margin-left: 10px;"> <p>The radio is connected. Tap the button to disconnect.</p> </div> </div> </div>

Icon	Description
	SMS The SMS button is enabled if no Internet connection is active. When this button is active, tapping it accesses the integrated SMS application.
	Web Tap this button to launch the default browser.
	Email Tap this button to launch the default Email application.
	GPS Tap this button access the integrated GPS tool.

Information Buttons

Icon	Description
	Radio On/Off Tap this button to switch the radio state . The color of this button also indicates the state of the radio:  The radio is On. Tap the button to turn the radio Off.  The radio is Off. Tap the button to turn the radio On.  The radio is Connecting or the radio has been disabled. The button is inactive at this time.
	Statistics Show/Hide  Tap the button to expand the screen to include connection statistics .  Tap the button to hide the connection statistics.
	Settings Tap this button to access connection settings . Select from several tabs to configure the connection settings.
	Update Tap this button to access OneClick Internet updates .
	Help Click this button to view the on-line help .
Status	 Ready. Tap the Connect button to establish a connection.  Connecting. Tap the Cancel button to cancel the connection in process.  Connected. Tap the Disconnect button to end the connection.  Failure. Review the screen for messages such as "No Network", etc.



Chapter 5: Key Maps

64-Key QWERTY Keypad Key Map



- Because the keyboard only has 64 keys, all functions are not visible (or printed on the keyboard). Therefore the Thor VM1 keyboard supports what is called hidden keys – keys that are accessible but not visible on the keyboard.
- The keypad does not have a NumLock indicator or key. NumLock is always On.

The Thor VM1 keyboard is backlit.

- By default, the keyboard backlight follows the display backlight. When the display backlight is on, the keyboard backlight is on.
- If the display backlight brightness is increased (or decreased) the keyboard backlight brightness is increased (or decreased).
- The keyboard backlight and the display share the same timer, which is configured in [Start > Control Panel > Power](#).

Note: When automatic brightness control is enabled for a Thor VM1 with an Outdoor display, the manual display brightness controls in the table below have no effect.

To get this Key / Function	Press These Keys in this Order	
Power On/Suspend	Power	
2nd mode	2nd	
Volume Up	2nd	F9
Volume Down	2nd	F10

Display Backlight Brightness Up	2nd	F7 (see note above)
Display Backlight Brightness Down	2nd	F8 (see note above)
Shift	Shift	
Alt	Alt	
Ctrl	Ctrl	
Esc	Esc	
Space	Space	
CapsLock	2nd	Shift
Enter	Enter	
Delete	Del	
. (VK_DECIMAL)	.	
Back Space	BkSp	
Insert	2nd	BkSp
Tab	Tab	
Back Tab	2nd Tab	
Ctrl-Break		
Pause		
Up Arrow	Up Arrow	
Down Arrow	Down Arrow	
Right Arrow	Right Arrow	
Left Arrow	Left Arrow	
Page Up	2nd	Up Arrow
Page Down	2nd	Down Arrow
End	2nd	Right Arrow
Home	2nd	Left Arrow
F1 - F10	F1 - F10	
F11 - F20	Shift	F1 - F10
F21 - F30	Alt	F1 - F10
F31 - F40	Ctrl	F1 - F10
a	A	
b	B	
c	C	
d	D	
e	E	
f	F	

g	G	
h	H	
i	I	
j	J	
k	K	
l	L	
m	M	
n	N	
o	O	
p	P	
q	Q	
r	R	
s	S	
t	T	
u	U	
v	V	
w	W	
x	X	
y	Y	
z	Z	
A	Shift	A
B	Shift	B
C	Shift	C
D	Shift	D
E	Shift	E
F	Shift	F
G	Shift	G
H	Shift	H
I	Shift	I
J	Shift	J
K	Shift	K
L	Shift	L
M	Shift	M
N	Shift	N
O	Shift	O

P	Shift	P
Q	Shift	Q
R	Shift	R
S	Shift	S
T	Shift	T
U	Shift	U
V	Shift	V
W	Shift	W
X	Shift	X
Y	Shift	Y
Z	Shift	Z
	2nd	A
~	2nd	B
:	2nd	D
#	2nd	E
;	2nd	F
"	2nd	G
'	2nd	H
*	2nd	I
,	2nd	J
.(VK_PERIOD)	2nd	K
?	2nd	L
_	2nd	M
`	2nd	N
(2nd	O
)	2nd	P
!	2nd	Q
\$	2nd	R
\	2nd	S
%	2nd	T
&	2nd	U
@	2nd	W
^	2nd	Y
1	1	
2	2	

3	3	
4	4	
5	5	
6	6	
7	7	
8	8	
9	9	
0	0	
>	2nd	1
[2nd	2
]	2nd	3
=	2nd	4
{	2nd	5
}	2nd	6
/	2nd	7
-	2nd	8
+	2nd	9
<	2nd	0
!	Shift	1
@	Shift	2
#	Shift	3
\$	Shift	4
%	Shift	5
^	Shift	6
&	Shift	7
*	Shift	8
(Shift	9
)	Shift	0

IBM Terminal Emulation

The Thor VM1/IBM 3270 and IBM 5250 Terminal Emulator keypads are designed to allow the user to enter terminal emulator commands when running the RFTerm program. When running RFTerm on the Thor VM1, please refer to the *RFTerm Reference Guide* for equivalent keys and keypress sequences.

IBM 3270



Legend on Keypad	Explanation	Key Sequence
Attn	Attention	Ctrl + A
Clr	Clear	Ctrl + C
Del	Delete	Ctrl + D
E-Inp	Erase Input	Ctrl + BkSp
Ins	Insert	Ctrl + I
NL	New Line	Ctrl + N
PA1		Ctrl + F1
PA2		Ctrl + F2
PA3		Ctrl + F3
Rst	Reset	Ctrl + R
SysReq	System	Ctrl + S

IBM 5250



Legend on Keypad	Explanation	Key Sequence
Attn	Attention	Ctrl + A
Clr	Clear	Ctrl + C
Del	Delete	Ctrl + D
Dup	Duplicate	Ctrl + U
E-Inp	Erase Input	Ctrl + Bksp
Field Exit	Enter	Enter
Fld -	Field Minus	Ctrl + M
Fld +	Field Plus	Ctrl + L
Ins	Insert	Ctrl + I
NL	New Line	Ctrl + N
SysReq	System	Ctrl + S



Chapter 6: Technical Specifications

Thor VM1

Processor	Atom CPU operating at 1.6 GHz.
Memory	2GB SDRAM
Mass Storage	4 or 8GB CompactFlash
Storage Expansion	User installable , supports 1 to 4GB SD card
Operating System	Microsoft Windows Embedded Standard 2009
Radio Modules	802.11 a/b/g/n radio / Bluetooth Optional GPS / WWAN
Scanner Options	No integrated scanner Optional serial, USB or Bluetooth scanners.
Display Technology	Controller: WVGA compatible controller Active matrix TFT Resolution: 800 x 480 pixels 400 NIT (indoor) or 900 NIT (outdoor) brightness 8" (measured horizontally) display Transmissive with LED backlight Automatic brightness control on outdoor display Vehicle motion screen blanking available
Touch Screen	Impact resistive Signature capture capability Optional defroster Field replaceable front panel including touch screen and optional defroster
External Connectors	Optional external 802.11 / GPS / WWAN antenna connectors Additional connectors on Quick Mount Smart Dock, see below .
Beeper	Minimum loudness greater than 95dBm at 10 cm in front of unit
Uninterruptible Power Supply	Internal UPS battery, field replaceable
Backup Battery (RCT)	Internal lithium Battery maintains Real Time Clock

Quick Mount Smart Dock

External Connectors	Two external RS-232 serial ports, COM1 and COM2, with switchable power CANbus/Audio connector supports either audio/microphone via adapter cable or J1939 Female and J1939 Male connectors via CANbus cable USB Host Port via adapter cable (USB Client Port not available)
Power Connector	5-pin connector. 10-60V DC input power
Power Switch	Sealed power switch
External Power Supply	External power supply. AC Adapter. 120-240VAC to 12VDC
Input Power	DC Input Voltage: 10- 60 VDC Input Current: 4.6 Amps Input Fuse: 10A Time Delay

Dimensions

Thor VM1

Width	10.6" (26.8 cm)
Height	8.4" (21.4 cm)
Depth	1.7" (4.3 cm) to 2.6" (6.6 cm) (at latch)
Weight	5.6 lb. (2.1 kg)

Quick Mount Smart Dock

Note: The RAM ball is not included in the following measurements.

Length	7.1" (18.0 cm)
Width	6.1" (15.5 cm)
Height	2.5" (6.4 cm)
Weight	3.2 lb. (1.2 kg)

Environmental Specifications

Thor VM1 and Quick Mount Smart Dock

Operating Temperature	Standard: -4°F to 122°F (-20°C to 50°C) [non-condensing] Extended temperature: -22° to 122° F (-30°C to 50°C) [condensing]
Storage Temperature	Standard and Extended temperature: -22°F to 140°F (-30°C to 60°C) [non-condensing]
ESD	8 KV air, 4kV direct contact
Operating Humidity	Standard: Up to 90% non-condensing at 104°F (40°C) Extended temperature: 100%
Water and Dust	IEC 60529 compliant to IP66
ESD	15 kV
Vibration	MIL-STD-810F, composite wheeled vehicles.
Crash	SAE-J 1455

Network Card Specifications

Summit 802.11 a/b/g/n

Bus Interface	32-bit PCIe Mini Card
Wireless Frequencies (varies by regulatory domain)	2.4 to 2.4895 GHz IEEE 802.11b / 802.11g DSSS OFDM 5.15 to 5.82 GHz IEEE 802.11a DSSS OFDM
RF Data Rates	802.11a (OFDM) 6, 9, 12, 18, 24, 36, 48, 54 Mbps 802.11b (DSSS) 1, 2, 5.5, 11 Mbps 802.11g (OFDM) 6, 9, 12, 18, 24, 36, 48, 54 Mbps 802.11n (OFDM 20 MHz chs) 13, 26, 39, 52, 78, 104, 117, 130 Mbps 802.11n (OFDM 40 MHz chs) 27, 54, 81, 108, 162, 216, 243, 270 Mbps
RF Power Level	50 mW max.
Channels	FCC: 1-11, 36, 40, 44, 48, 149, 153, 157, 161 ETSI: 1-13, 36, 40, 44, 48
Operating Temperature	Same as Thor VM1 Operating Temperature
Storage Temperature	Same as Thor VM1 Storage Temperature
Connectivity	TCP/IP, Ethernet, ODI
Diversity	Yes

Bluetooth

Bus Interface	CompactFlash
Enhanced Data Rate	Up to 3.0 Mbit/s over the air
Connection	No less than 32.80 feet (10 meters) line of sight
Bluetooth Version	2.0 + EDR
Operating Frequency	2.402 - 2.480 GHz
QDID	B013455

Chapter 7: Technical Assistance

If you need assistance installing or troubleshooting your device, please contact us by using one of the methods below:

Knowledge Base: www.hsmknowledgebase.com

Our Knowledge Base provides thousands of immediate solutions. If the Knowledge Base cannot help, our Technical Support Portal (see below) provides an easy way to report your problem or ask your question.

Technical Support Portal: www.hsmsupportportal.com

The Technical Support Portal not only allows you to report your problem, but it also provides immediate solutions to your technical issues by searching our Knowledge Base. With the Portal, you can submit and track your questions online and send and receive attachments.

Web form: www.hsmcontactsupport.com

You can contact our technical support team directly by filling out our online support form. Enter your contact details and the description of the question/problem.

Telephone: www.honeywellaidc.com/locations

For our latest contact information, please check our website at the link above.

Product Service and Repair

Honeywell International Inc. provides service for all of its products through service centers throughout the world. To obtain warranty or non-warranty service, please visit www.honeywellaidc.com and select **Support > Contact Service and Repair** to see your region's instructions on how to obtain a Return Material Authorization number (RMA #). You should do this prior to returning the product.

Limited Warranty

Honeywell International Inc. ("HII") warrants its products to be free from defects in materials and workmanship and to conform to HII's published specifications applicable to the products purchased at the time of shipment. This warranty does not cover any HII product which is (i) improperly installed or used; (ii) damaged by accident or negligence, including failure to follow the proper maintenance, service, and cleaning schedule; or (iii) damaged as a result of (A) modification or alteration by the purchaser or other party, (B) excessive voltage or current supplied to or drawn from the interface connections, (C) static electricity or electro-static discharge, (D) operation under conditions beyond the specified operating parameters, or (E) repair or service of the product by anyone other than HII or its authorized representatives.

This warranty shall extend from the time of shipment for the duration published by HII for the product at the time of purchase ("Warranty Period"). Any defective product must be returned (at purchaser's expense) during the Warranty Period to HII factory or authorized service center for inspection. No product will be accepted by HII without a Return Materials Authorization, which may be obtained by contacting HII. In the event that the product is returned to HII or its authorized service center within the Warranty Period and HII determines to its satisfaction that the product is defective due to defects in materials or workmanship, HII, at its sole option, will either repair or replace the product without charge, except for return shipping to HII.

EXCEPT AS MAY BE OTHERWISE PROVIDED BY APPLICABLE LAW, THE FOREGOING WARRANTY IS IN LIEU OF ALL OTHER COVENANTS OR WARRANTIES, EITHER EXPRESSED OR IMPLIED, ORAL OR WRITTEN, INCLUDING, WITHOUT LIMITATION, ANY IMPLIED WARRANTIES OF MERCHANTABILITY OR FITNESS FOR A PARTICULAR PURPOSE, OR NON-INFRINGEMENT.

HII'S RESPONSIBILITY AND PURCHASER'S EXCLUSIVE REMEDY UNDER THIS WARRANTY IS LIMITED TO THE REPAIR OR REPLACEMENT OF THE DEFECTIVE PRODUCT WITH NEW OR REFURBISHED PARTS. IN NO EVENT

SHALL HII BE LIABLE FOR INDIRECT, INCIDENTAL, OR CONSEQUENTIAL DAMAGES, AND, IN NO EVENT, SHALL ANY LIABILITY OF HII ARISING IN CONNECTION WITH ANY PRODUCT SOLD HEREUNDER (WHETHER SUCH LIABILITY ARISES FROM A CLAIM BASED ON CONTRACT, WARRANTY, TORT, OR OTHERWISE) EXCEED THE ACTUAL AMOUNT PAID TO HII FOR THE PRODUCT. THESE LIMITATIONS ON LIABILITY SHALL REMAIN IN FULL FORCE AND EFFECT EVEN WHEN HII MAY HAVE BEEN ADVISED OF THE POSSIBILITY OF SUCH INJURIES, LOSSES, OR DAMAGES. SOME STATES, PROVINCES, OR COUNTRIES DO NOT ALLOW THE EXCLUSION OR LIMITATIONS OF INCIDENTAL OR CONSEQUENTIAL DAMAGES, SO THE ABOVE LIMITATION OR EXCLUSION MAY NOT APPLY TO YOU.

All provisions of this Limited Warranty are separate and severable, which means that if any provision is held invalid and unenforceable, such determination shall not affect the validity of enforceability of the other provisions hereof. Use of any peripherals not provided by the manufacturer may result in damage not covered by this warranty. This includes but is not limited to: cables, power supplies, cradles, and docking stations. HII extends these warranties only to the first end-users of the products. These warranties are non-transferable.

The duration of the limited warranty for the Thor VM1 is 1 year.

The duration of the limited warranty for the Thor VM1 Quick Mount Smart Dock is 1 year.

The duration of the limited warranty for the Thor VM1 Vehicle Mount Assembly is 1 year.

The duration of the limited warranty for the Thor VM1 internal UPS battery is 1 year.

The duration of the limited warranty for the Thor VM1 AC power supply and cables is 1 year.

The duration of the limited warranty for the Thor VM1 DC-DC Converter is 1 year.

The duration of the limited warranty for the Thor VM1 cables (USB, Serial, Communication, Power) is 1 year.



Honeywell Scanning & Mobility
9680 Old Bailes Road
Fort Mill, SC 29707
www.honeywellaidc.com

E-EQ-VM1WESRG
Rev C
10/12