

PROPERTY AND EXISTING R/W LINE	---
REQUIRED R/W LINE	---
CONSTRUCTION LIMITS	---
EASEMENT FOR CONSTR & MAINTENANCE OF SLOPES	---
EASEMENT FOR CONSTR OF SLOPES	---
EASEMENT FOR CONSTR OF DRIVES	---
PAVEMENT/MEDIAN REMOVAL	---

BEGIN LIMIT OF ACCESS.....BLA	---
END LIMIT OF ACCESS.....ELA	---
LIMIT OF ACCESS	---
REQ'D R/W & LIMIT OF ACCESS	---
ORANGE BARRIER FENCE	---
ESA - ENV. SENSITIVE AREA (SEE ERIT TABLE)	---

PLANS PREPARED AND SUBMITTED BY:

AEI

AMERICAN ENGINEERS, INC.

DESIGN CONSULTANT

PROFESSIONAL ENGINEERING

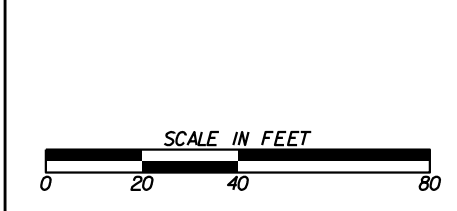

REVISION DATES	

SIGNING AND MARKING PLANS			
SR 369/MATT HWY			
CHECKED:	DATE:	DRAWING No.	
BACKCHECKED:	DATE:	26-0001	
CORRECTED:	DATE:		
VERIFIED:	DATE:		

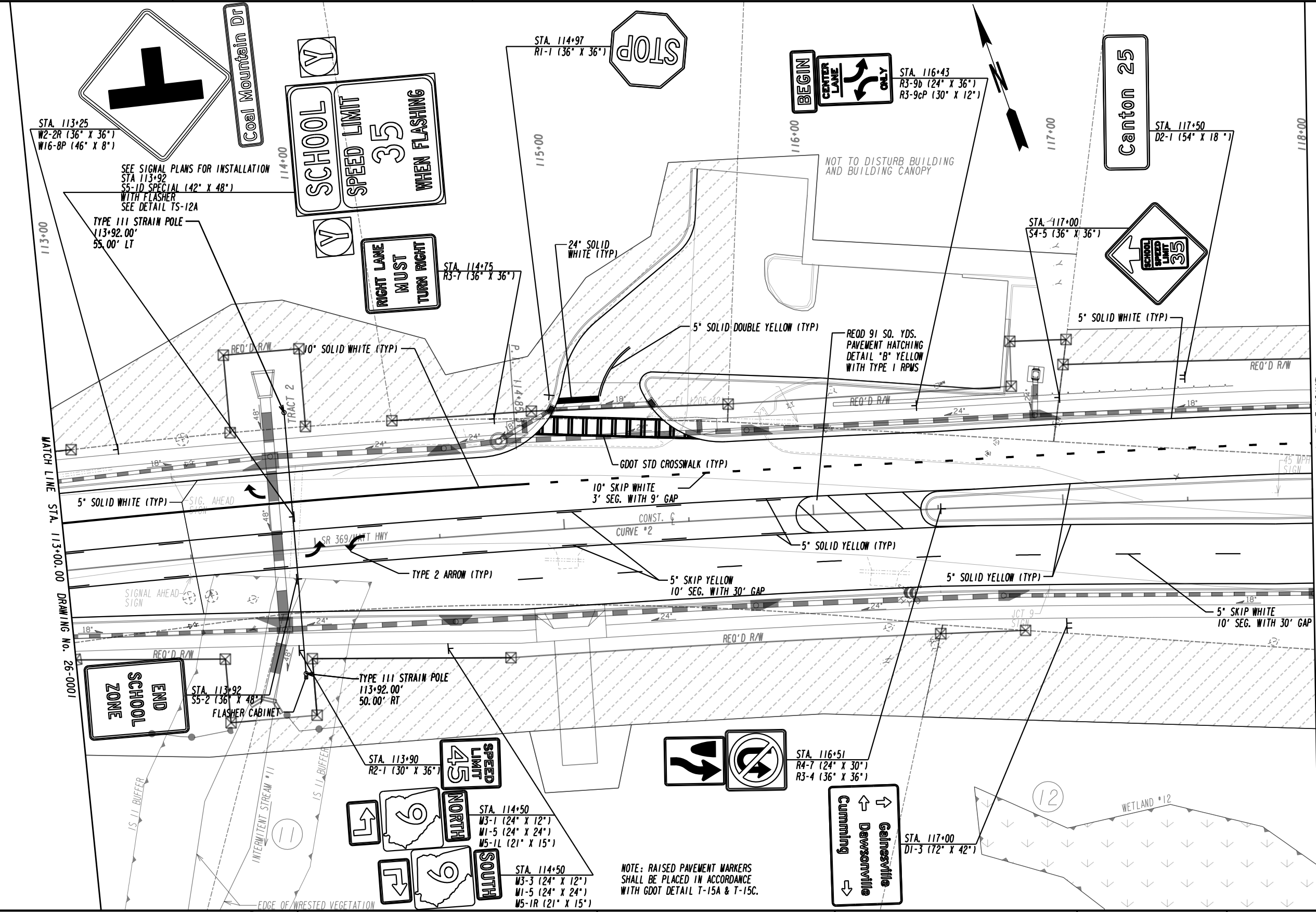

MATCH LINE STA. 113+00.00 DRAWING No. 26-0001

MATCH LINE STA. 118+00.00 DRAWING No. 26-0003

PROPERTY AND EXISTING R/W LINE	---
REQUIRED R/W LINE	---
CONSTRUCTION LIMITS	---
EASEMENT FOR CONSTR & MAINTENANCE OF SLOPES	---
EASEMENT FOR CONSTR OF SLOPES	---
EASEMENT FOR CONSTR OF DRIVES	---
PAVEMENT/MEDIAN REMOVAL	---

BEGIN LIMIT OF ACCESS.....BLA	---
END LIMIT OF ACCESS.....ELA	---
LIMIT OF ACCESS	---
REQ'D R/W & LIMIT OF ACCESS	---
ORANGE BARRIER FENCE	---
ESA - ENV. SENSITIVE AREA (SEE ERIT TABLE)	---

PLANS PREPARED AND SUBMITTED BY:

AEI

AMERICAN ENGINEERS, INC.

DESIGN CONSULTANT

PROFESSIONAL ENGINEERING

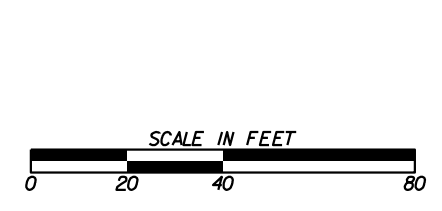

REVISION DATES	

SIGNING AND MARKING PLANS			
SR 369/MATT HWY			
CHECKED:	DATE:	DRAWING No.	
BACKCHECKED:	DATE:	26-0002	
CORRECTED:	DATE:		
VERIFIED:	DATE:		

NOTE: RAISED PAVEMENT MARKERS SHALL BE PLACED IN ACCORDANCE WITH GDOT DETAIL T-15A & T-15C.

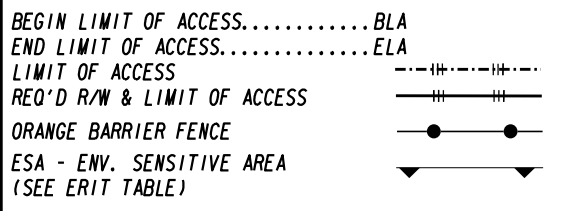
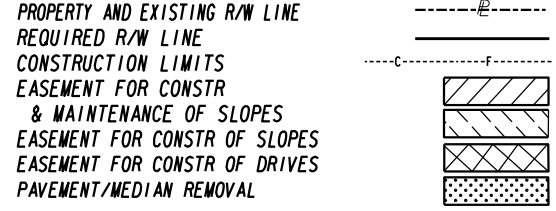
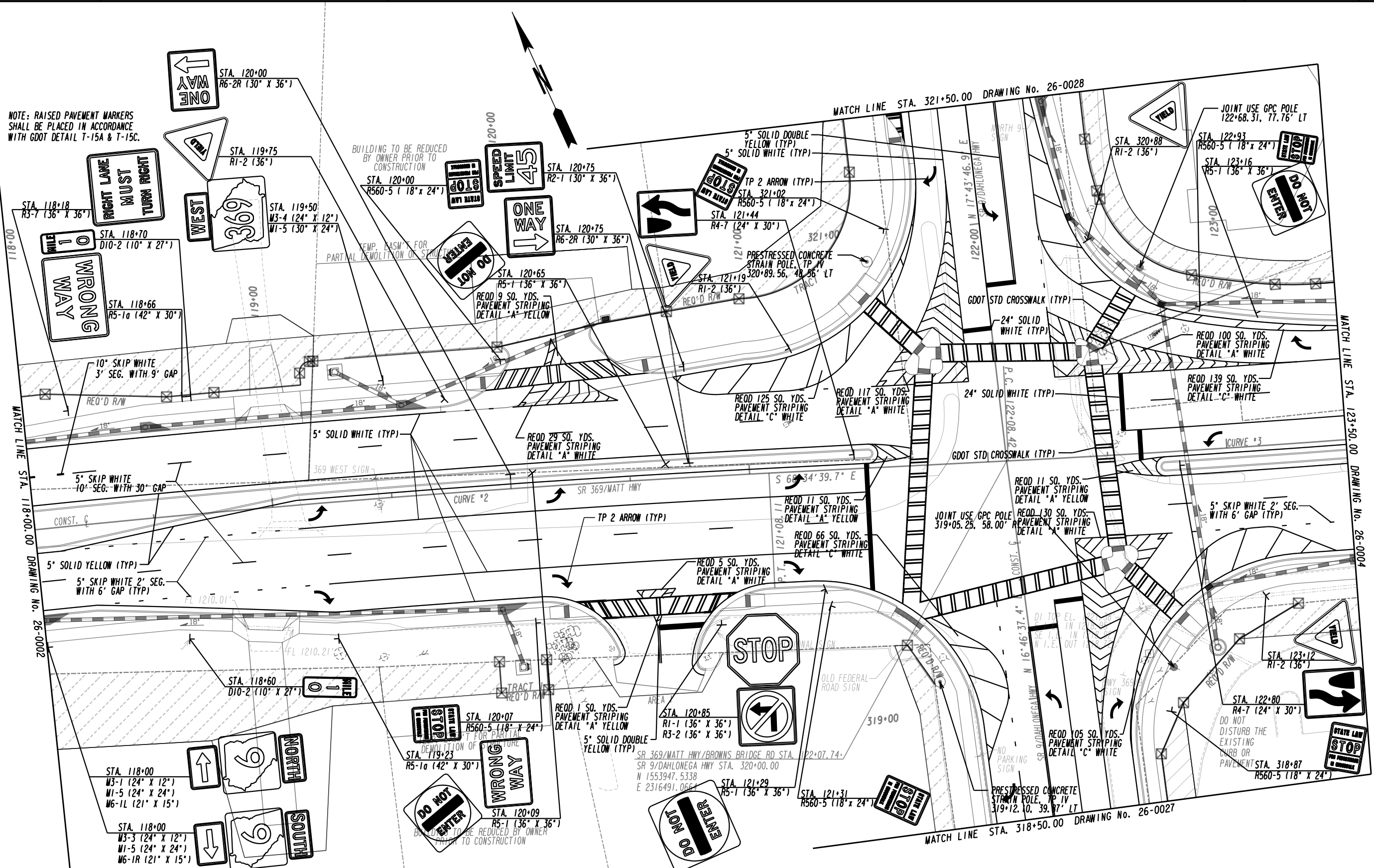

PLANS PREPARED AND SUBMITTED BY:

AEI
 65 Aberdeen Drive
 Glasgow, KY 40424
 (270) 651-7220

2500 Nelson Miller Parkway
 Louisville, KY 40223
 (502) 245-3813

AMERICAN ENGINEERS, INC.
 www.aei.co

DESIGN CONSULTANT

PROFESSIONAL ENGINEERING

634 White Circle, Suite 101
 McLeansville, GA 30056
 (770) 421-8422

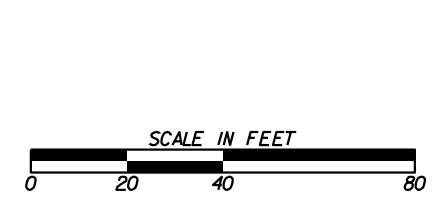

REVISION DATES	

SIGNING AND MARKING PLANS		
SR 369/MATT HWY/BROWNS BRIDGE RD SR 9/DAHLONEGA HWY		
CHECKED:	DATE:	DRAWING No.
BACKCHECKED:	DATE:	26-0003
CORRECTED:	DATE:	
VERIFIED:	DATE:	

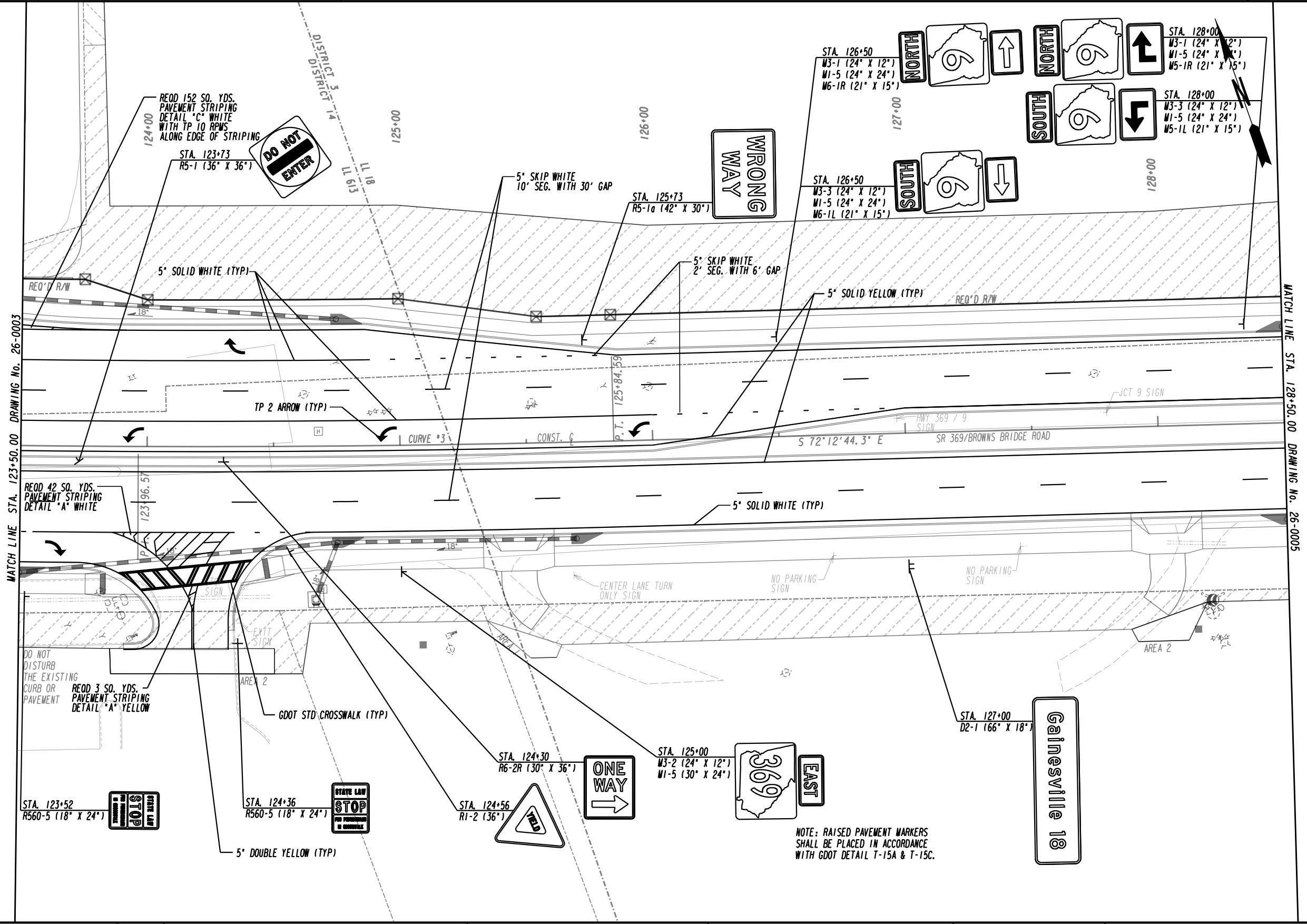

MATCH LINE STA. 123+50.00 DRAWING No. 26-0003

MATCH LINE STA. 128+50.00 DRAWING No. 26-0005

PROPERTY AND EXISTING R/W LINE
 REQUIRED R/W LINE
 CONSTRUCTION LIMITS
 EASEMENT FOR CONSTR
 & MAINTENANCE OF SLOPES
 EASEMENT FOR CONSTR OF SLOPES
 EASEMENT FOR CONSTR OF DRIVES
 PAVEMENT/MEDIAN REMOVAL

BEGIN LIMIT OF ACCESS.....BLA
 END LIMIT OF ACCESS.....ELA
 LIMIT OF ACCESS
 REQ'D R/W & LIMIT OF ACCESS
 ORANGE BARRIER FENCE
 ESA - ENV. SENSITIVE AREA
 (SEE ERIT TABLE)

PLANS PREPARED AND SUBMITTED BY:
 Branch Office
 65 Aberdeen Drive
 Glasgow, KY 42041
 (270) 651-7220
 2500 Nelson Miller Parkway
 Louisville, KY 40223
 (502) 245-3813
AMERICAN ENGINEERS, INC.
 DESIGN CONSULTANT PROFESSIONAL ENGINEERING

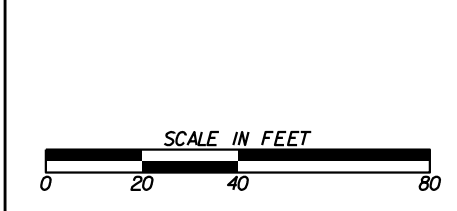

REVISION DATES	

SIGNING AND MARKING PLANS			
SR 369/BROWNS BRIDGE RD			
CHECKED:		DATE:	
BACKCHECKED:		DATE:	
CORRECTED:		DATE:	
VERIFIED:		DATE:	
DRAWING No.			26-0004

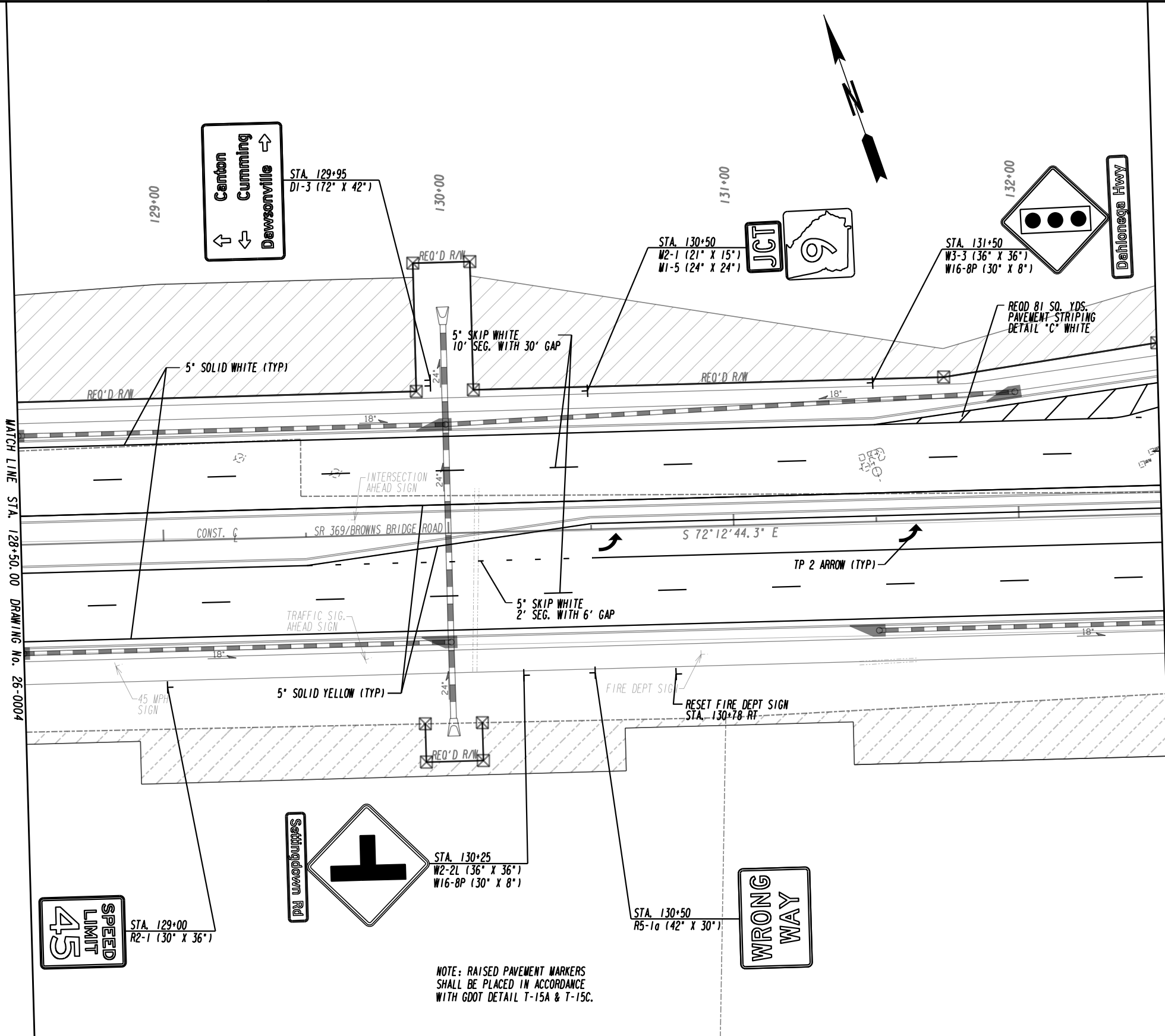

MATCH LINE STA. 128+50.00 DRAWING No. 26-0004

MATCH LINE STA. 132+50.00 DRAWING No. 26-0006

NOTE: RAISED PAVEMENT MARKERS SHALL BE PLACED IN ACCORDANCE WITH GDOT DETAIL T-15A & T-15C.

PROPERTY AND EXISTING R/W LINE	---
REQUIRED R/W LINE	---
CONSTRUCTION LIMITS	---
EASEMENT FOR CONSTR & MAINTENANCE OF SLOPES	---
EASEMENT FOR CONSTR OF SLOPES	---
EASEMENT FOR CONSTR OF DRIVES	---
PAVEMENT/MEDIAN REMOVAL	---

BEGIN LIMIT OF ACCESS.....BLA	---
END LIMIT OF ACCESS.....ELA	---
LIMIT OF ACCESS	---
REQ'D R/W & LIMIT OF ACCESS	---
ORANGE BARRIER FENCE	---
ESA - ENV. SENSITIVE AREA (SEE ERIT TABLE)	---

PLANS PREPARED AND SUBMITTED BY:

AEI
AMERICAN ENGINEERS, INC.
www.aei.cc

DESIGN CONSULTANT

PROFESSIONAL ENGINEERING



REVISION DATES	

SIGNING AND MARKING PLANS			
SR 369/BROWNS BRIDGE RD			
CHECKED:		DATE:	
BACKCHECKED:		DATE:	
CORRECTED:		DATE:	
VERIFIED:		DATE:	
DRAWING No.			26-0005

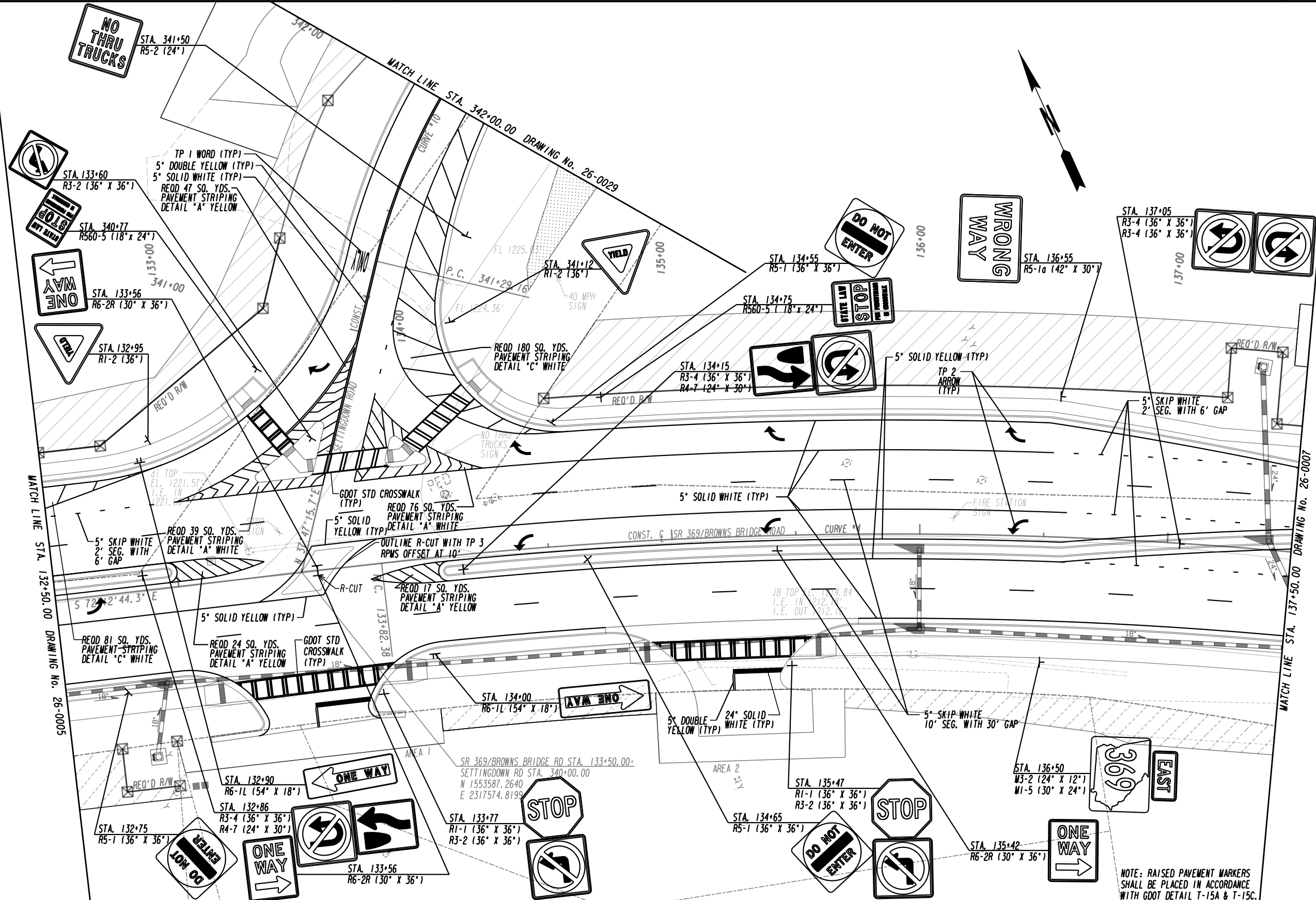

PROPERTY AND EXISTING R/W LINE
 REQUIRED R/W LINE
 CONSTRUCTION LIMITS
 EASEMENT FOR CONSTR
 & MAINTENANCE OF SLOPES
 EASEMENT FOR CONSTR OF SLOPES
 EASEMENT FOR CONSTR OF DRIVES
 PAVEMENT/MEDIAN REMOVAL

BEGIN LIMIT OF ACCESS.....BLA
 END LIMIT OF ACCESS.....ELA
 LIMIT OF ACCESS
 REQ'D R/W & LIMIT OF ACCESS
 ORANGE BARRIER FENCE
 ESA - ENV. SENSITIVE AREA
 (SEE ERIT TABLE)

PLANS PREPARED AND SUBMITTED BY:
 AMERICAN ENGINEERS, INC.
 DESIGN CONSULTANT

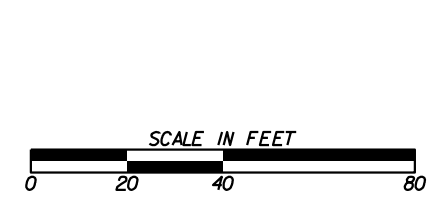

REVISION DATES	

SIGNING AND MARKING PLANS
 SR 369/BROWNS BRIDGE RD
 SETTINGDOWN RD

CHECKED:	DATE:	DRAWING No.
BACKCHECKED:	DATE:	26-0006
CORRECTED:	DATE:	
VERIFIED:	DATE:	

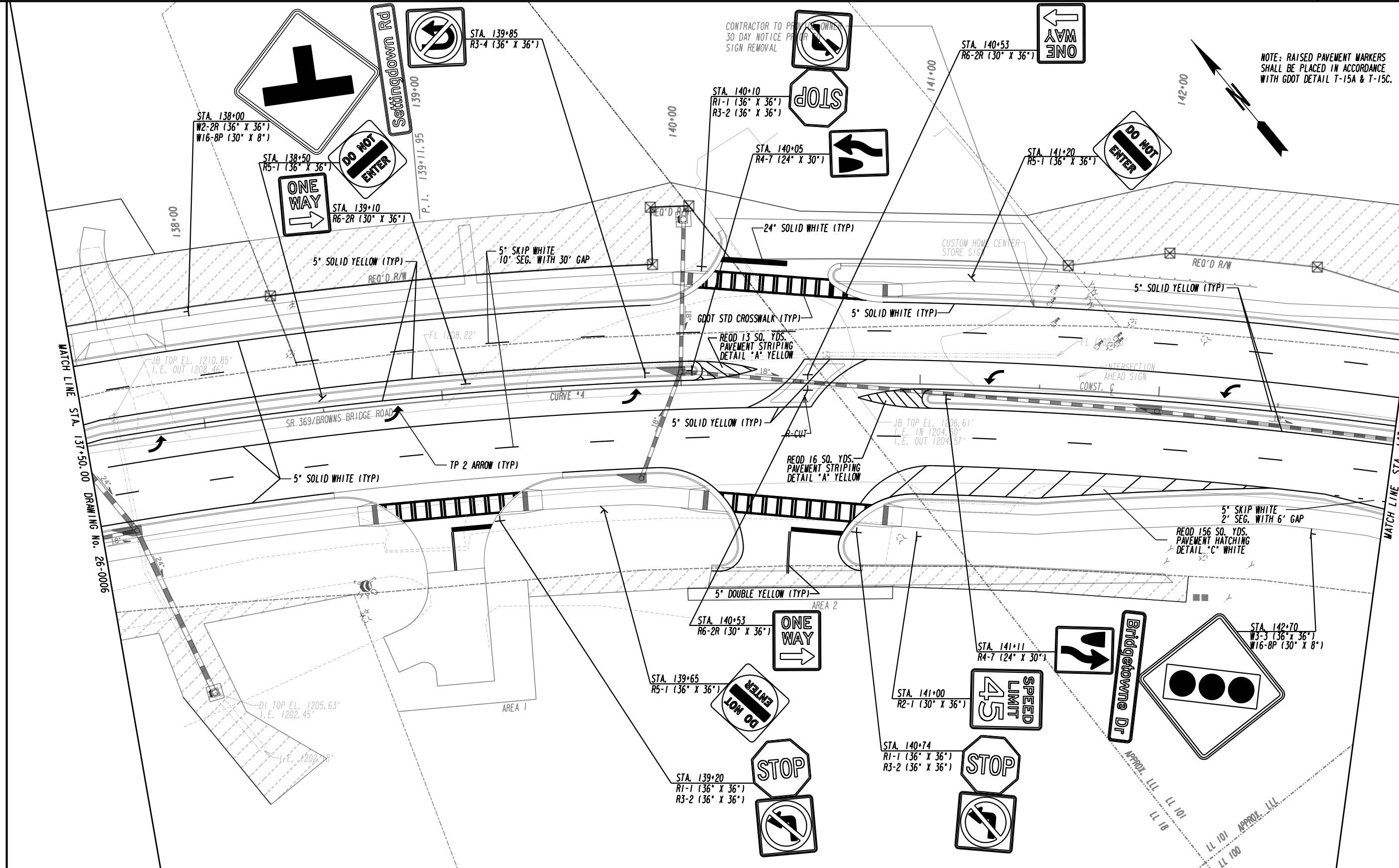

NOTE: RAISED PAVEMENT MARKERS SHALL BE PLACED IN ACCORDANCE WITH GDOT DETAIL T-15A & T-15C.

PROPERTY AND EXISTING R/W LINE
REQUIRED R/W LINE
CONSTRUCTION LIMITS
EASEMENT FOR CONSTR
& MAINTENANCE OF SLOPES
EASEMENT FOR CONSTR OF SLOPES
EASEMENT FOR CONSTR OF DRIVES
PAVEMENT/MEDIAN REMOVAL

BEGIN LIMIT OF ACCESS.....BLA
END LIMIT OF ACCESS.....ELA
LIMIT OF ACCESS
REQ'D R/W & LIMIT OF ACCESS
ORANGE BARRIER FENCE
ESA - ENV. SENSITIVE AREA
(SEE ERIT TABLE)

PLANS PREPARED AND SUBMITTED BY:

AEI
AMERICAN ENGINEERS, INC.
DESIGN CONSULTANT

PROFESSIONAL ENGINEERING

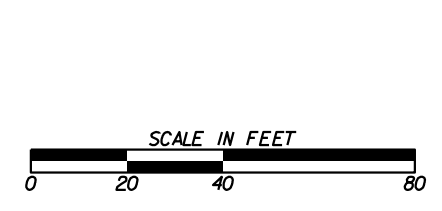

REVISION DATES

SIGNING AND MARKING PLANS

SR 369/BROWNS BRIDGE RD

CHECKED:	DATE:	DRAWING No.
BACKCHECKED:	DATE:	26-0007
CORRECTED:	DATE:	
VERIFIED:	DATE:	

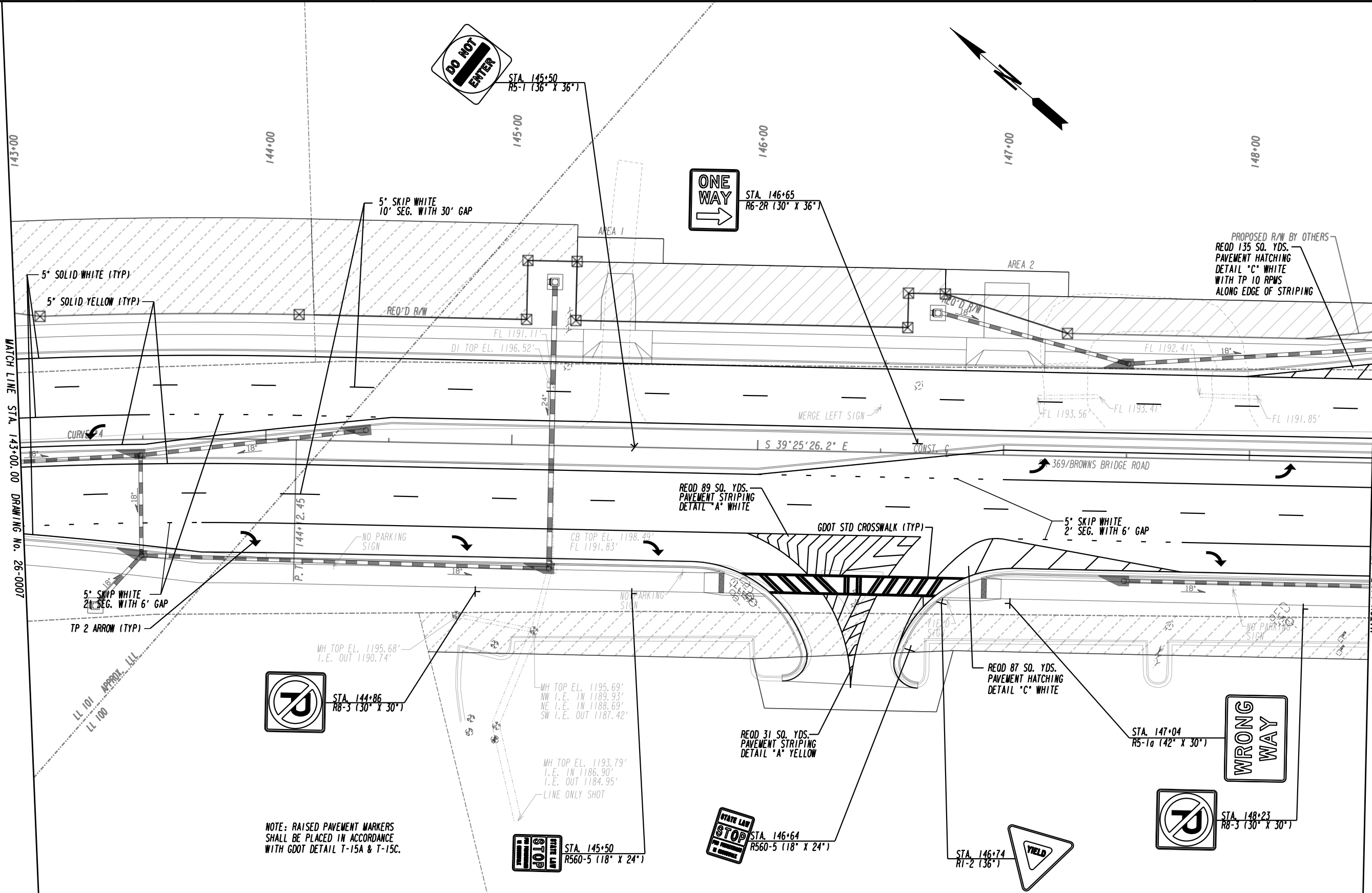

MATCH LINE STA. 143+00.00 DRAWING No. 26-0007

MATCH LINE STA. 148+50.00 DRAWING No. 26-0009

NOTE: RAISED PAVEMENT MARKERS SHALL BE PLACED IN ACCORDANCE WITH GDOT DETAIL T-15A & T-15C.

PROPERTY AND EXISTING R/W LINE	---
REQUIRED R/W LINE	---
CONSTRUCTION LIMITS	---
EASEMENT FOR CONSTR & MAINTENANCE OF SLOPES	---
EASEMENT FOR CONSTR OF SLOPES	---
EASEMENT FOR CONSTR OF DRIVES	---
PAVEMENT/MEDIAN REMOVAL	---

BEGIN LIMIT OF ACCESS.....BLA	---
END LIMIT OF ACCESS.....ELA	---
LIMIT OF ACCESS	---
REQ'D R/W & LIMIT OF ACCESS	---
ORANGE BARRIER FENCE	---
ESA - ENV. SENSITIVE AREA (SEE ERIT TABLE)	---

PLANS PREPARED AND SUBMITTED BY:

AEI
AMERICAN ENGINEERS, INC.
www.aei.cc

DESIGN CONSULTANT

PROFESSIONAL ENGINEERING

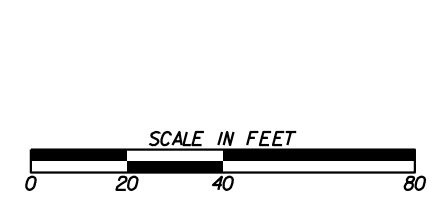

REVISION DATES	

SIGNING AND MARKING PLANS		
SR 369/BROWNS BRIDGE RD		
CHECKED:	DATE:	DRAWING No. 26-0008
BACKCHECKED:	DATE:	
CORRECTED:	DATE:	
VERIFIED:	DATE:	

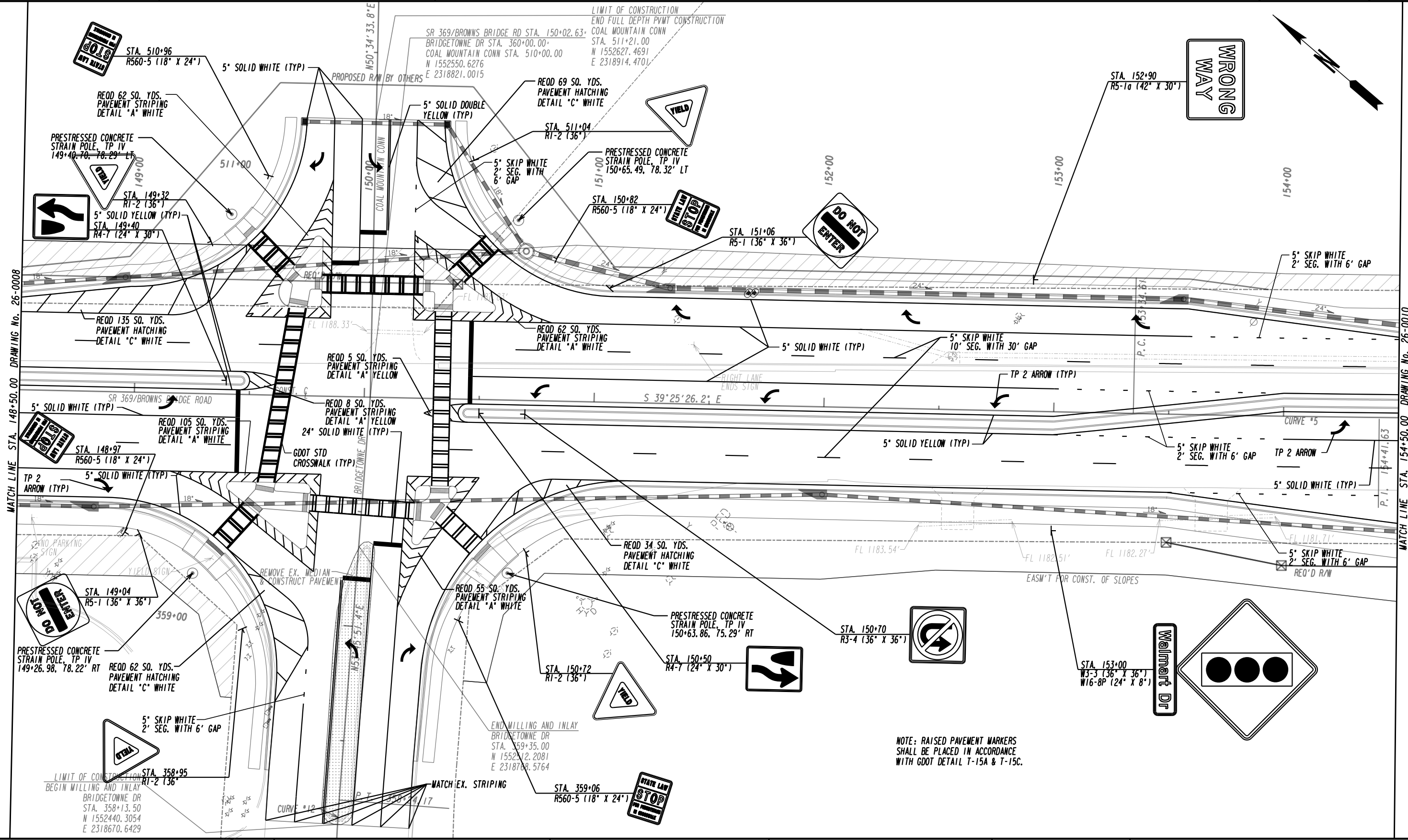

PROPERTY AND EXISTING R/W LINE
REQUIRED R/W LINE
CONSTRUCTION LIMITS
EASEMENT FOR CONSTR
& MAINTENANCE OF SLOPES
EASEMENT FOR CONSTR OF SLOPES
EASEMENT FOR CONSTR OF DRIVES
PAVEMENT/MEDIAN REMOVAL

---	---
---	---
---	---
---	---
---	---
---	---
---	---
---	---

BEGIN LIMIT OF ACCESS.....BLA
END LIMIT OF ACCESS.....ELA
LIMIT OF ACCESS
REQ'D R/W & LIMIT OF ACCESS
ORANGE BARRIER FENCE
ESA - ENV. SENSITIVE AREA
(SEE ERIT TABLE)

---	---
---	---
---	---
---	---
---	---
---	---
---	---
---	---

PLANS PREPARED AND SUBMITTED BY:

AEI
AMERICAN ENGINEERS, INC.
DESIGN CONSULTANT

PROFESSIONAL ENGINEERING

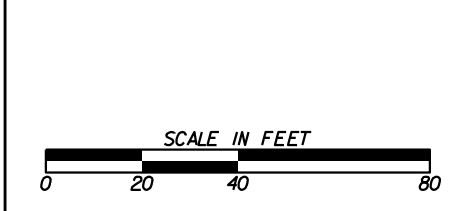

REVISION DATES

SIGNING AND MARKING PLANS

SR 369/BROWNS BRIDGE RD

CHECKED:		DATE:		DRAWING No.	
BACKCHECKED:		DATE:			
CORRECTED:		DATE:			
VERIFIED:		DATE:			

26-0009

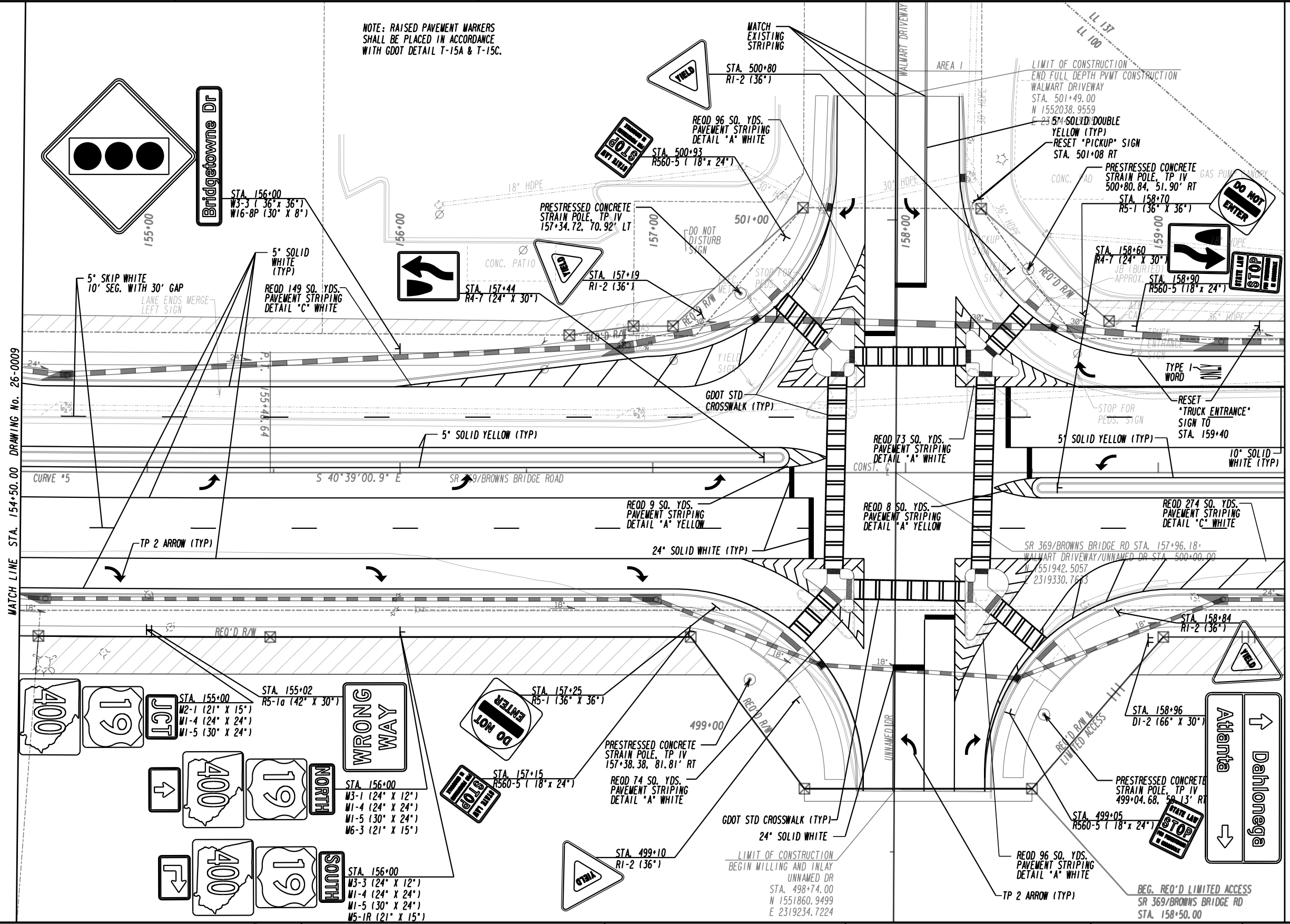

NOTE: RAISED PAVEMENT MARKERS SHALL BE PLACED IN ACCORDANCE WITH GDOT DETAIL T-15A & T-15C.

MATCH LINE STA. 159+50.00 DRAWING No. 26-0011

MATCH LINE STA. 154+50.00 DRAWING No. 26-0009

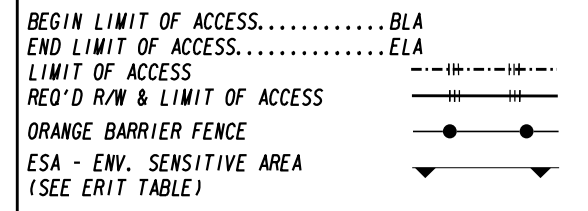
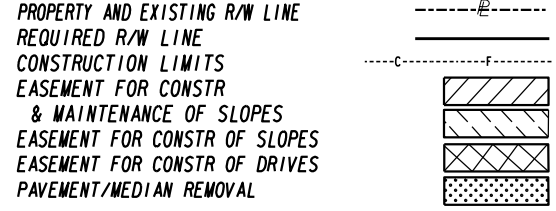

PLANS PREPARED AND SUBMITTED BY:

AEI
 AMERICAN ENGINEERS, INC.
 www.aei.cc

DESIGN CONSULTANT

PROFESSIONAL ENGINEERING

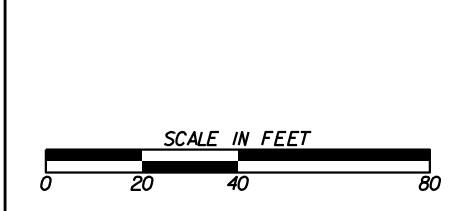

REVISION DATES	

SIGNING AND MARKING PLANS			
SR 369/BROWNS BRIDGE RD			
CHECKED:	DATE:	DRAWING No.	
BACKCHECKED:	DATE:	26-0010	
CORRECTED:	DATE:		
VERIFIED:	DATE:		

NOTE: RAISED PAVEMENT MARKERS SHALL BE PLACED IN ACCORDANCE WITH GDOT DETAIL T-15A & T-15C.

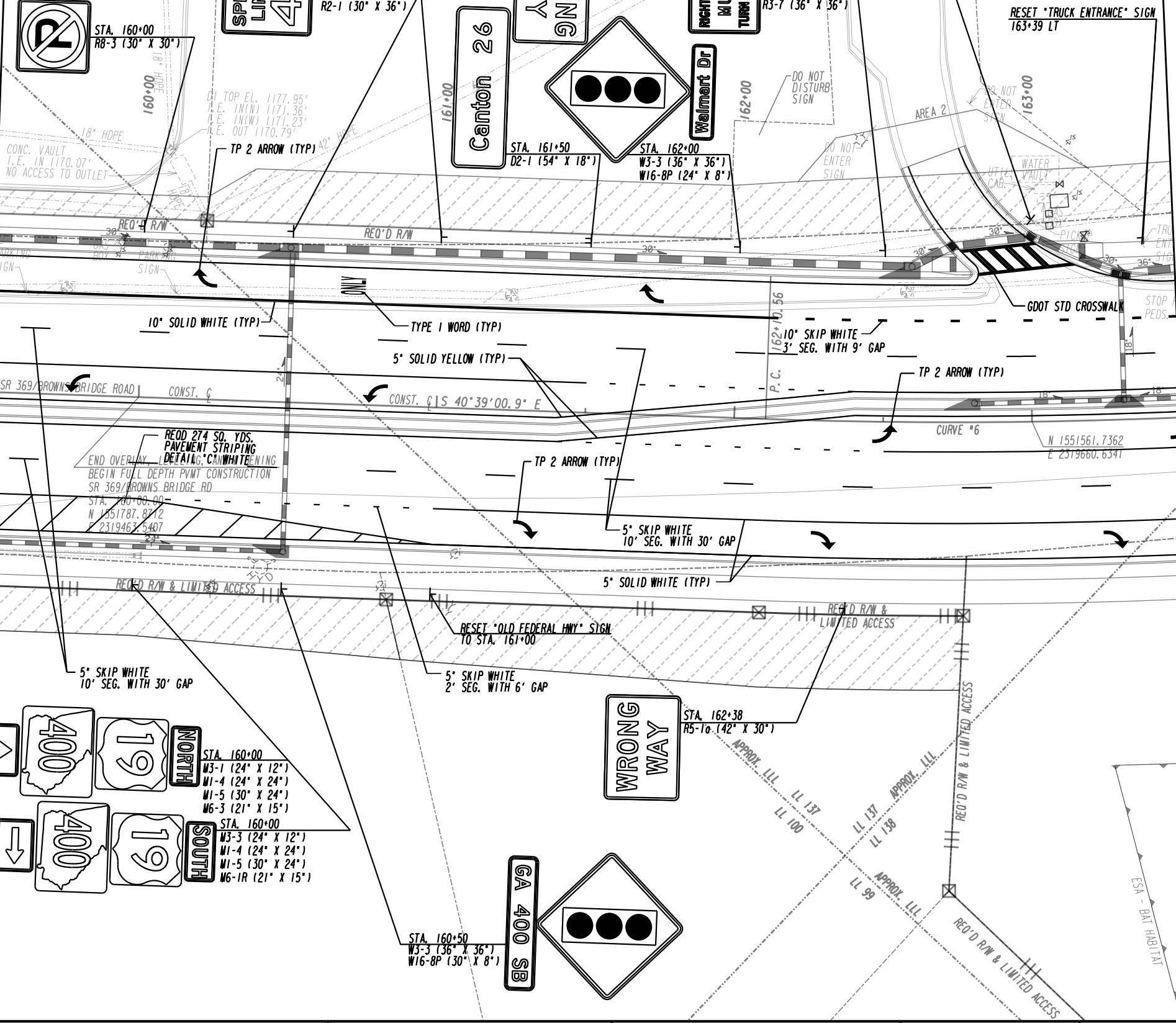

MATCH LINE STA. 159+50.00 DRAWING No. 26-0010

MATCH LINE STA. 163+50.00 DRAWING No. 26-0012

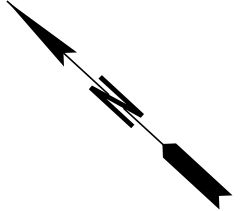

- STA. 160+00
- M3-1 (24" X 12")
 - M1-4 (24" X 24")
 - M1-5 (30" X 24")
 - M6-3 (21" X 15")
- STA. 160+00
- M3-3 (24" X 12")
 - M1-4 (24" X 24")
 - M1-5 (30" X 24")
 - M6-1R (21" X 15")

PROPERTY AND EXISTING R/W LINE	---
REQUIRED R/W LINE	---
CONSTRUCTION LIMITS	---
EASEMENT FOR CONSTR & MAINTENANCE OF SLOPES	---
EASEMENT FOR CONSTR OF SLOPES	---
EASEMENT FOR CONSTR OF DRIVES	---
PAVEMENT/MEDIAN REMOVAL	---

BEGIN LIMIT OF ACCESS.....BLA	---
END LIMIT OF ACCESS.....ELA	---
LIMIT OF ACCESS	---
REQ'D R/W & LIMIT OF ACCESS	---
ORANGE BARRIER FENCE	---
ESA - ENV. SENSITIVE AREA (SEE ERIT TABLE)	---

PLANS PREPARED AND SUBMITTED BY:

AEI
AMERICAN ENGINEERS, INC.
DESIGN CONSULTANT

PROFESSIONAL ENGINEERING

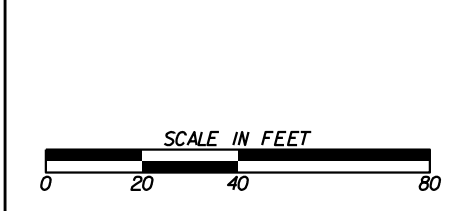

REVISION DATES	

SIGNING AND MARKING PLANS		
SR 369/BROWNS BRIDGE RD		
CHECKED:	DATE:	DRAWING No.
BACKCHECKED:	DATE:	26-0011
CORRECTED:	DATE:	
VERIFIED:	DATE:	

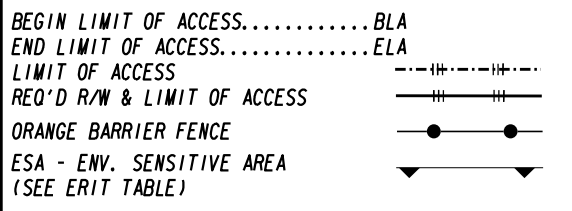
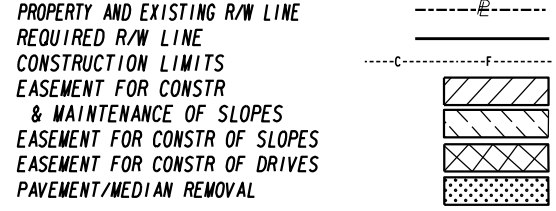
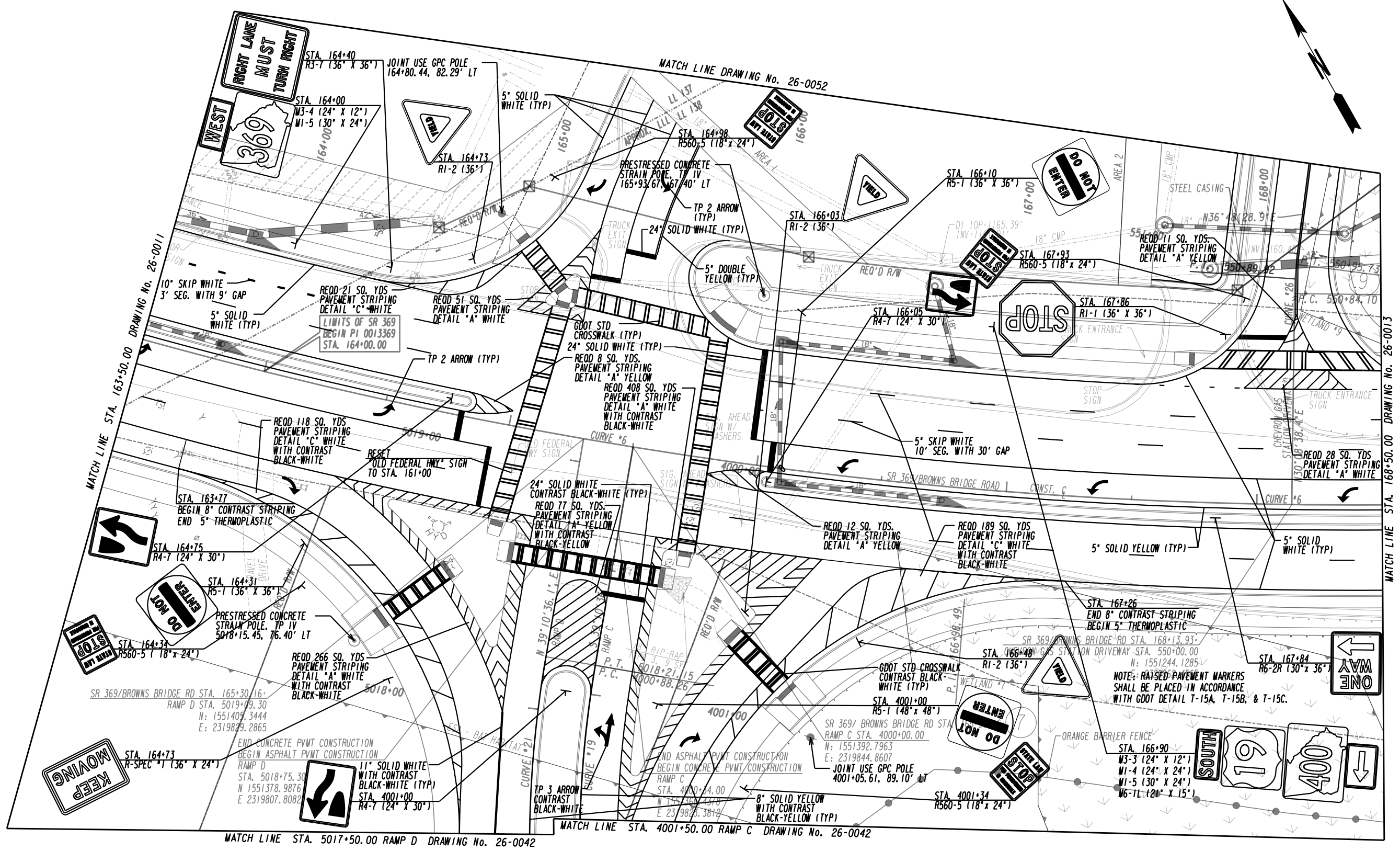

PLANS PREPARED AND SUBMITTED BY:

AEI
AMERICAN ENGINEERS, INC.
www.aei.cc

DESIGN CONSULTANT

PROFESSIONAL ENGINEERING

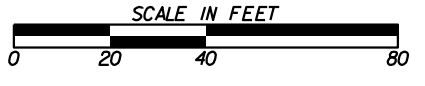

REVISION DATES	

SIGNING AND MARKING PLANS			
SR 369/BROWNS BRIDGE RD			
CHECKED:	DATE:	DRAWING No.	
BACKCHECKED:	DATE:	26-0012	
CORRECTED:	DATE:		
VERIFIED:	DATE:		

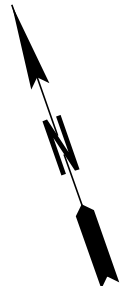
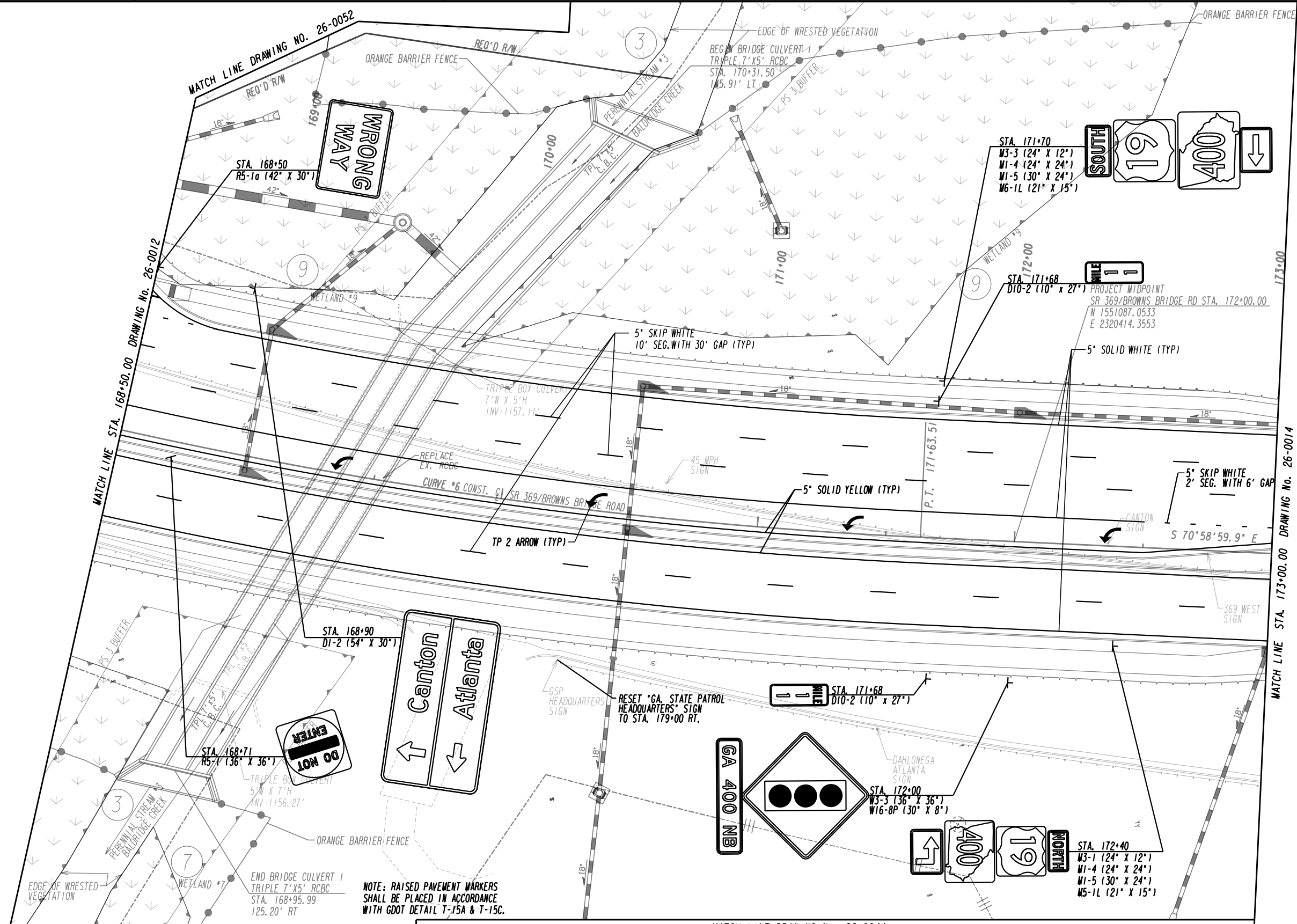

PROPERTY AND EXISTING R/W LINE
REQUIRED R/W LINE
CONSTRUCTION LIMITS
EASEMENT FOR CONSTR
& MAINTENANCE OF SLOPES
EASEMENT FOR CONSTR OF SLOPES
EASEMENT FOR CONSTR OF DRIVES
PAVEMENT/MEDIAN REMOVAL

---	---
---	---
---	---
---	---
---	---
---	---
---	---
---	---

BEGIN LIMIT OF ACCESS.....BLA
END LIMIT OF ACCESS.....ELA
LIMIT OF ACCESS
REQ'D R/W & LIMIT OF ACCESS
ORANGE BARRIER FENCE
ESA - ENV. SENSITIVE AREA
(SEE ERIT TABLE)

---	---
---	---
---	---
---	---
---	---
---	---

PLANS PREPARED AND SUBMITTED BY:

AEI
AMERICAN ENGINEERS, INC.
DESIGN CONSULTANT

PROFESSIONAL ENGINEERING

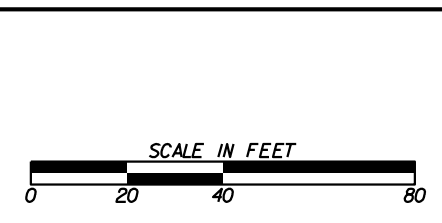

REVISION DATES

SIGNING AND MARKING PLANS

SR 369/BROWNS BRIDGE RD

CHECKED:	DATE:	DRAWING No.
BACKCHECKED:	DATE:	26-0013
CORRECTED:	DATE:	
VERIFIED:	DATE:	

NOTE: RAISED PAVEMENT MARKERS
SHALL BE PLACED IN ACCORDANCE
WITH GDOT DETAIL T-15A, T-15B, & T-15C.

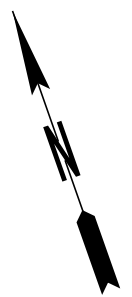
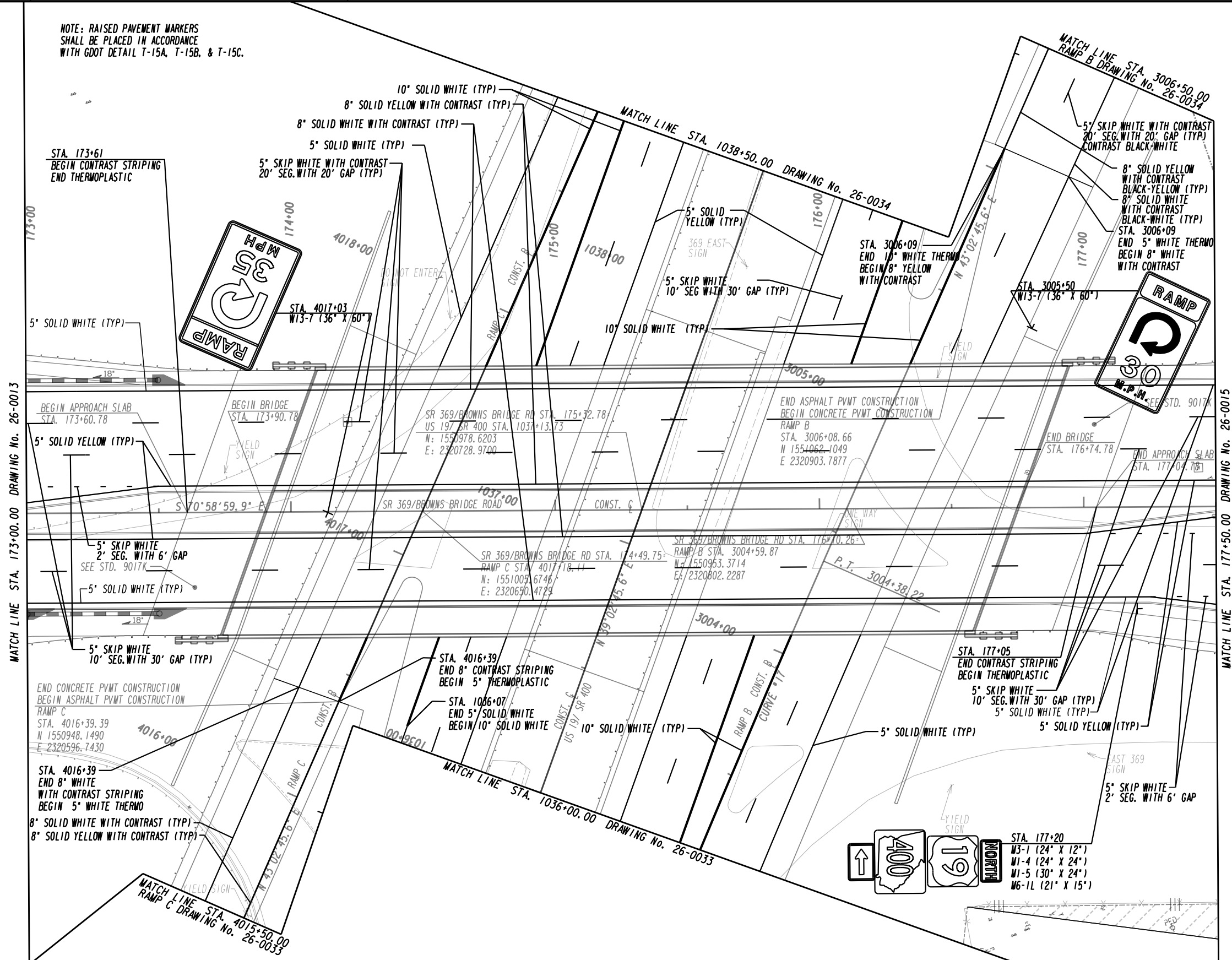

PROPERTY AND EXISTING R/W LINE	---
REQUIRED R/W LINE	---
CONSTRUCTION LIMITS	---
EASEMENT FOR CONSTR & MAINTENANCE OF SLOPES	---
EASEMENT FOR CONSTR OF SLOPES	---
EASEMENT FOR CONSTR OF DRIVES	---
PAVEMENT/MEDIAN REMOVAL	---

BEGIN LIMIT OF ACCESS.....BLA	---
END LIMIT OF ACCESS.....ELA	---
LIMIT OF ACCESS	---
REQ'D R/W & LIMIT OF ACCESS	---
ORANGE BARRIER FENCE	---
ESA - ENV. SENSITIVE AREA (SEE ERIT TABLE)	---

PLANS PREPARED AND SUBMITTED BY:

AEI
AMERICAN ENGINEERS, INC.
DESIGN CONSULTANT

PROFESSIONAL ENGINEERING

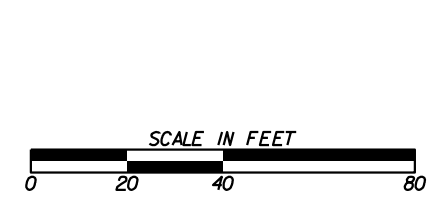

REVISION DATES	

SIGNING AND MARKING PLANS			
SR 369/BROWNS BRIDGE RD SR 400/US 19			
CHECKED:	DATE:	DRAWING No.	
BACKCHECKED:	DATE:	26-0014	
CORRECTED:	DATE:		
VERIFIED:	DATE:		

MATCH LINE DRAWING No. 26-0039

NOTE: RAISED PAVEMENT MARKERS SHALL BE PLACED IN ACCORDANCE WITH GDOT DETAIL T-15A & T-15C.

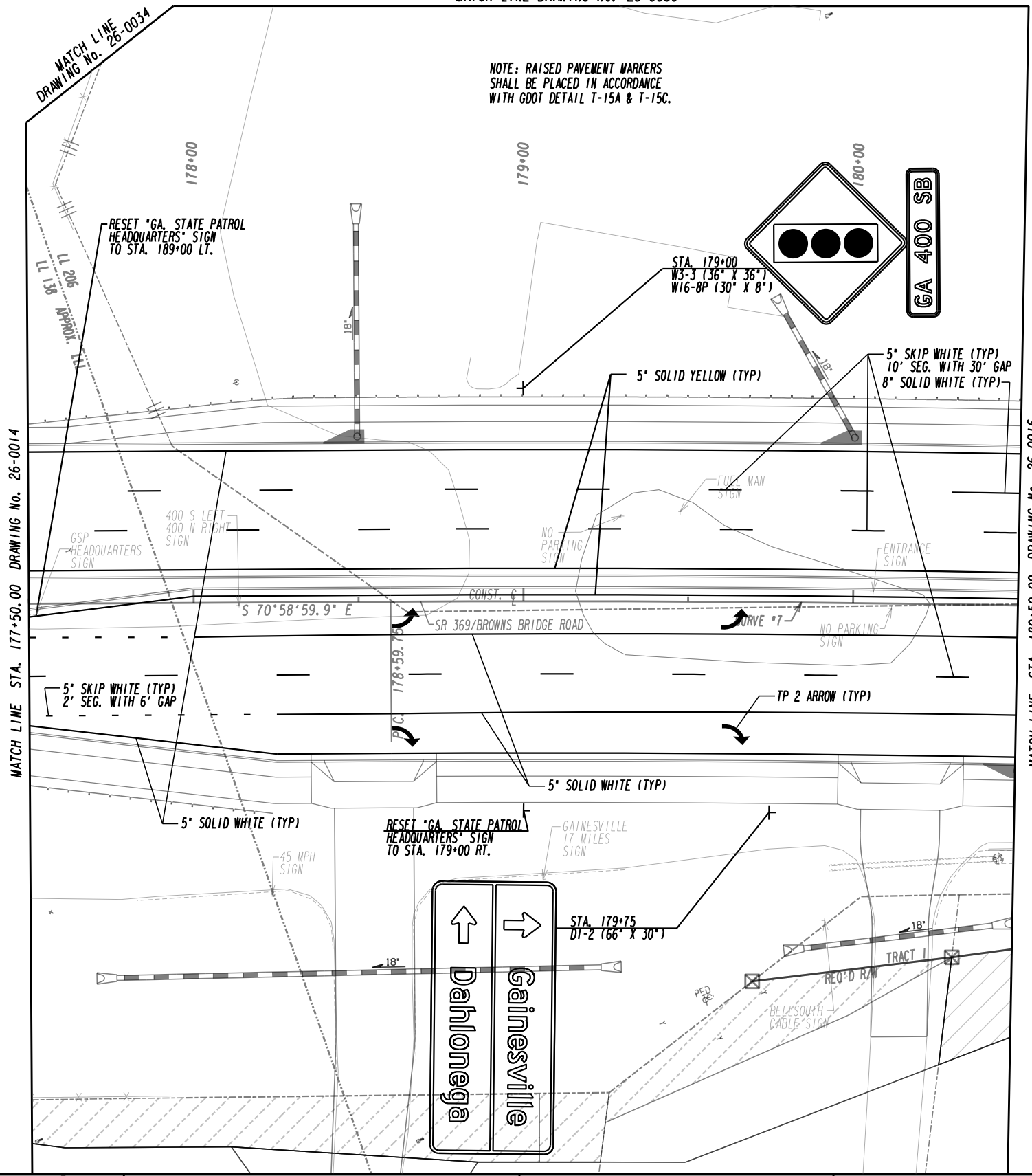

MATCH LINE STA. 177+50.00 DRAWING No. 26-0014

MATCH LINE STA. 180+50.00 DRAWING No. 26-0016

PROPERTY AND EXISTING R/W LINE
 REQUIRED R/W LINE
 CONSTRUCTION LIMITS
 EASEMENT FOR CONSTR
 & MAINTENANCE OF SLOPES
 EASEMENT FOR CONSTR OF SLOPES
 EASEMENT FOR CONSTR OF DRIVES
 PAVEMENT/MEDIAN REMOVAL

BEGIN LIMIT OF ACCESS.....BLA
 END LIMIT OF ACCESS.....ELA
 LIMIT OF ACCESS
 REQ'D R/W & LIMIT OF ACCESS
 ORANGE BARRIER FENCE
 ESA - ENV. SENSITIVE AREA
 (SEE ERIT TABLE)

PLANS PREPARED AND SUBMITTED BY:
 Branch Offices
 O 65 Aberdeen Drive
 Glasgow, KY 40304
 (270) 651-7220
 O 2500 Nelson Miller Parkway
 Louisville, KY 40223
 (502) 245-3813
 O 634 White Circle, Suite 101
 Marietta, GA 30066
 (770) 421-8422
AMERICAN ENGINEERS, INC.
 www.aei.cc
 DESIGN CONSULTANT PROFESSIONAL ENGINEERING

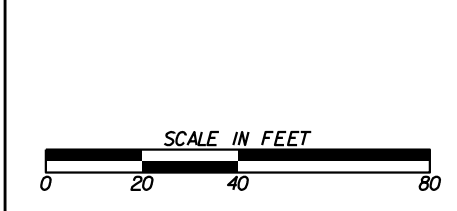

REVISION DATES	

SIGNING AND MARKING PLANS			
SR 369/BROWNS BRIDGE RD			
CHECKED:		DATE:	
BACKCHECKED:		DATE:	
CORRECTED:		DATE:	
VERIFIED:		DATE:	
DRAWING No.			26-0015

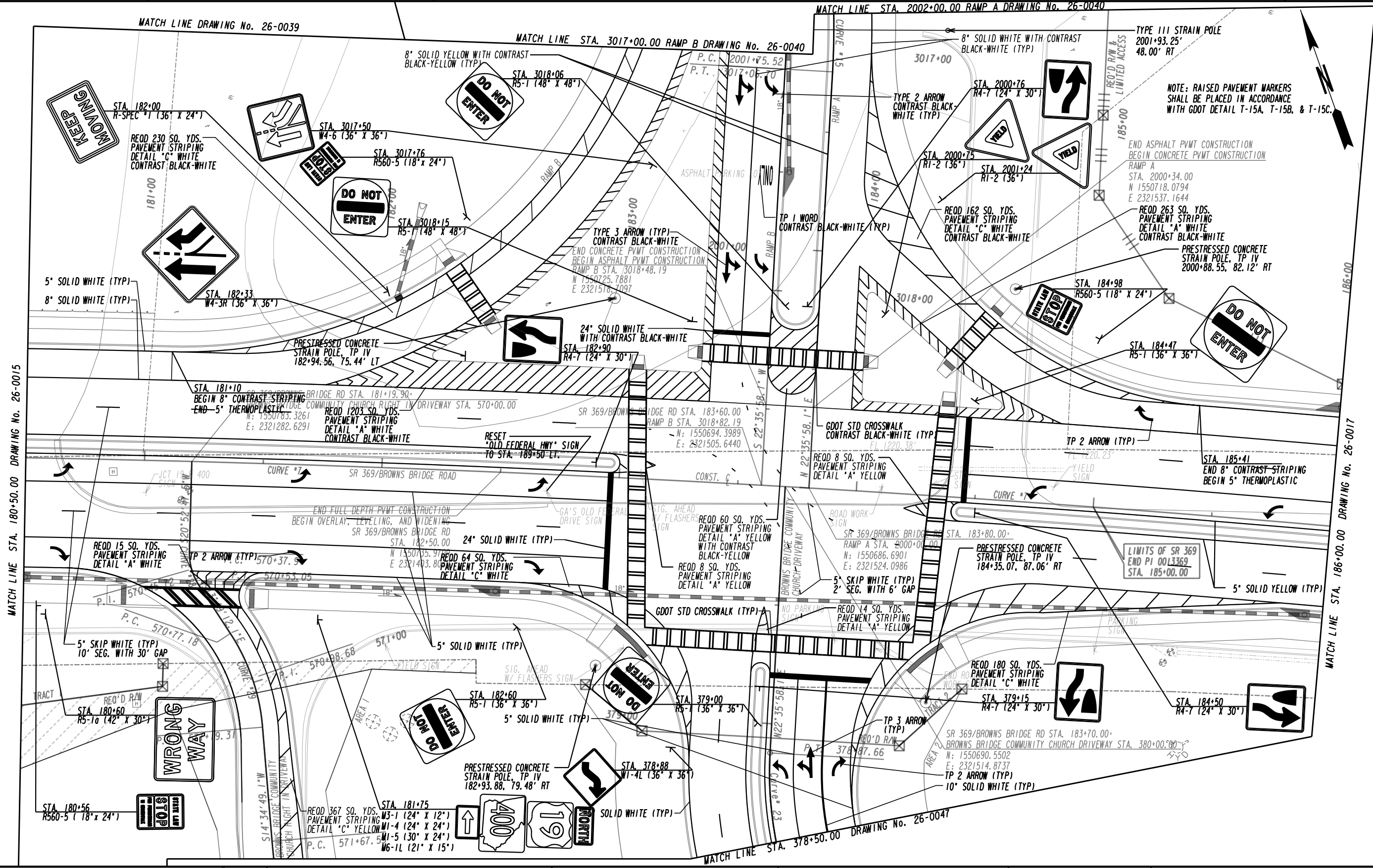

PROPERTY AND EXISTING R/W LINE
REQUIRED R/W LINE
CONSTRUCTION LIMITS
EASEMENT FOR CONSTR
& MAINTENANCE OF SLOPES
EASEMENT FOR CONSTR OF SLOPES
EASEMENT FOR CONSTR OF DRIVES
PAVEMENT/MEDIAN REMOVAL

BEGIN LIMIT OF ACCESS.....BLA
END LIMIT OF ACCESS.....ELA
LIMIT OF ACCESS
REQ'D R/W & LIMIT OF ACCESS
ORANGE BARRIER FENCE
ESA - ENV. SENSITIVE AREA
(SEE ERIT TABLE)

PLANS PREPARED AND SUBMITTED BY:

AEI
AMERICAN ENGINEERS, INC.
DESIGN CONSULTANT

PROFESSIONAL ENGINEERING

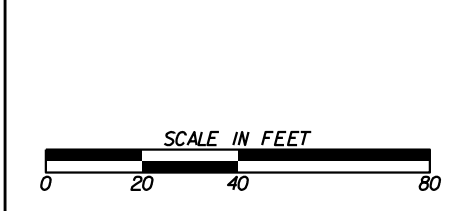

REVISION DATES

NO.	DATE	DESCRIPTION

SIGNING AND MARKING PLANS

SR 369/BROWNS BRIDGE RD

CHECKED:	DATE:	DRAWING No.
BACKCHECKED:	DATE:	26-0016
CORRECTED:	DATE:	
VERIFIED:	DATE:	

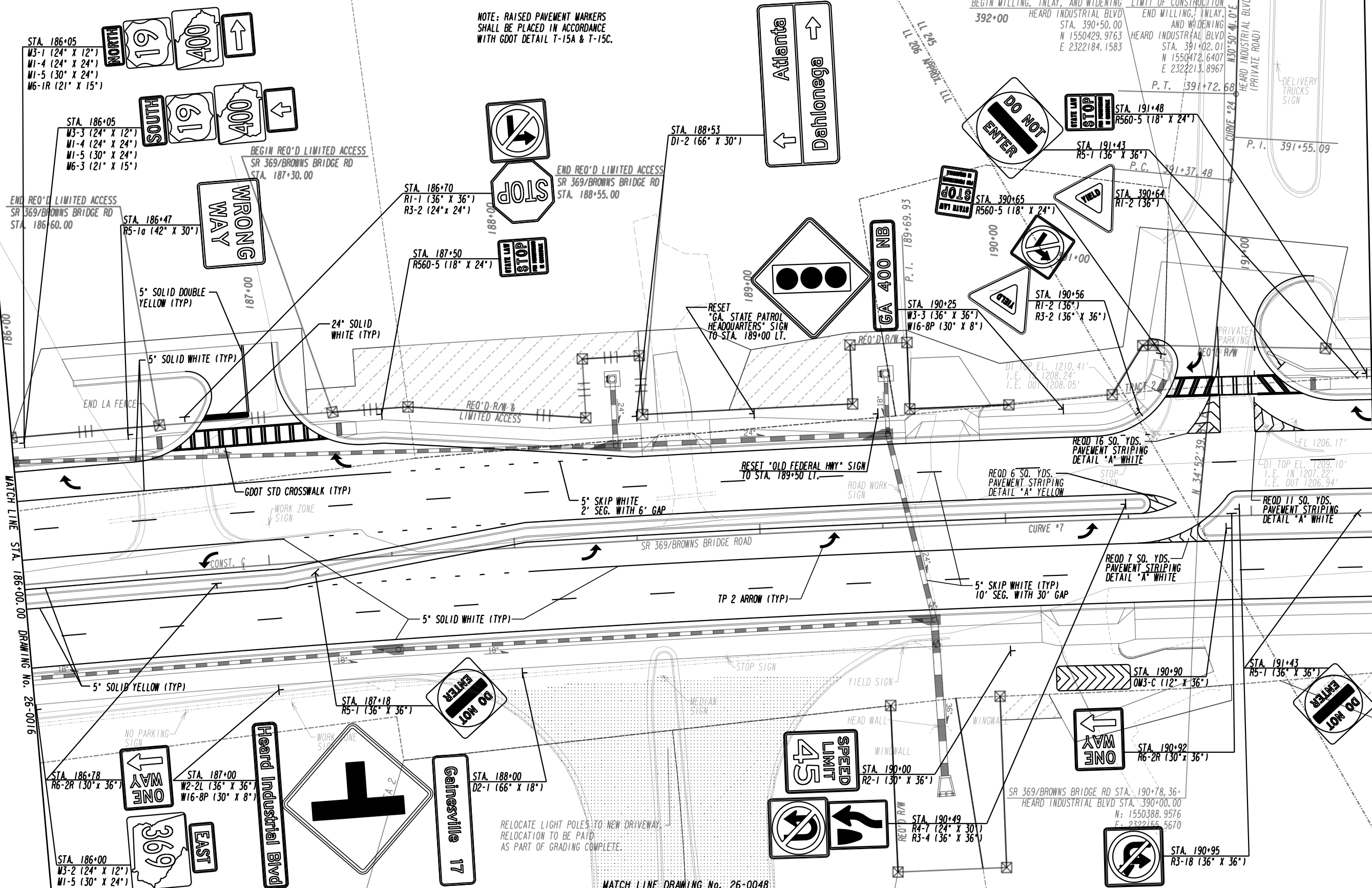

NOTE: RAISED PAVEMENT MARKERS SHALL BE PLACED IN ACCORDANCE WITH GDOT DETAIL T-15A & T-15C.

STA. 186+05
W3-1 (24" X 12")
W1-4 (24" X 24")
W1-5 (30" X 24")
W6-1R (21" X 15")

STA. 186+05
W3-3 (24" X 12")
W1-4 (24" X 24")
W1-5 (30" X 24")
W6-3 (21" X 15")

END REQ'D LIMITED ACCESS
SR 369/BROWNS BRIDGE RD
STA. 186+60.00

STA. 186+47
R5-1a (42" X 30")

5" SOLID DOUBLE YELLOW (TYP)

5" SOLID WHITE (TYP)

END LA FENCE

5" SOLID WHITE (TYP)

5" SOLID YELLOW (TYP)

5" SOLID WHITE (TYP)

5" SOLID WHITE (TYP)

5" SOLID WHITE (TYP)

5" SOLID WHITE (TYP)

5" SOLID WHITE (TYP)

5" SOLID WHITE (TYP)

5" SOLID WHITE (TYP)

5" SOLID WHITE (TYP)

5" SOLID WHITE (TYP)

PROPERTY AND EXISTING R/W LINE	---
REQUIRED R/W LINE	---
CONSTRUCTION LIMITS	---
EASEMENT FOR CONSTR & MAINTENANCE OF SLOPES	---
EASEMENT FOR CONSTR OF SLOPES	---
EASEMENT FOR CONSTR OF DRIVES	---
PAVEMENT/MEDIAN REMOVAL	---

BEGIN LIMIT OF ACCESS.....BLA	---
END LIMIT OF ACCESS.....ELA	---
LIMIT OF ACCESS	---
REQ'D R/W & LIMIT OF ACCESS	---
ORANGE BARRIER FENCE	---
ESA - ENV. SENSITIVE AREA (SEE ERIT TABLE)	---

PLANS PREPARED AND SUBMITTED BY:

AEI

AMERICAN ENGINEERS, INC.

DESIGN CONSULTANT

PROFESSIONAL ENGINEERING

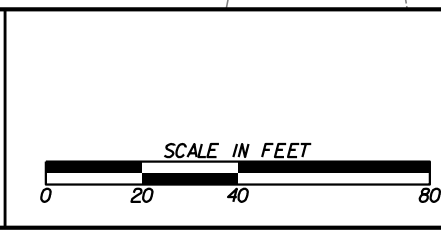

REVISION DATES	

SIGNING AND MARKING PLANS			
SR 369/BROWNS BRIDGE RD			
CHECKED:	DATE:	DRAWING No.	
BACKCHECKED:	DATE:	26-0017	
CORRECTED:	DATE:		
VERIFIED:	DATE:		

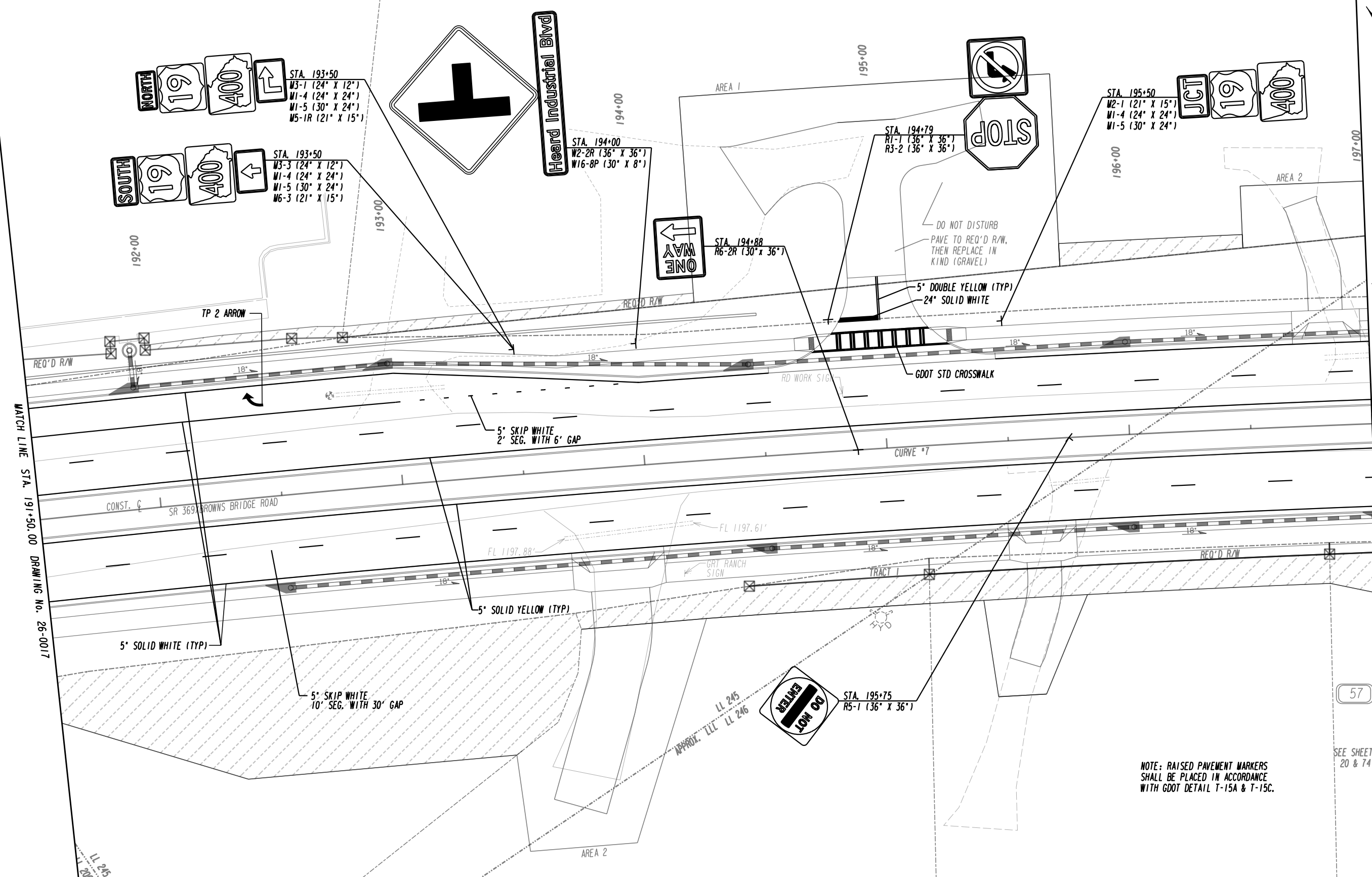

MATCH LINE STA. 191+50.00 DRAWING NO. 26-0017

MATCH LINE STA. 197+00.00 DRAWING NO. 26-0019

NOTE: RAISED PAVEMENT MARKERS SHALL BE PLACED IN ACCORDANCE WITH GDOT DETAIL T-15A & T-15C.

SEE SHEETS 20 & 74

PROPERTY AND EXISTING R/W LINE	---
REQUIRED R/W LINE	---
CONSTRUCTION LIMITS	---
EASEMENT FOR CONSTR & MAINTENANCE OF SLOPES	---
EASEMENT FOR CONSTR OF SLOPES	---
EASEMENT FOR CONSTR OF DRIVES	---
PAVEMENT/MEDIAN REMOVAL	---

BEGIN LIMIT OF ACCESS.....BLA	---
END LIMIT OF ACCESS.....ELA	---
LIMIT OF ACCESS	---
REQ'D R/W & LIMIT OF ACCESS	---
ORANGE BARRIER FENCE	---
ESA - ENV. SENSITIVE AREA (SEE ERIT TABLE)	---

PLANS PREPARED AND SUBMITTED BY:

AEI

AMERICAN ENGINEERS, INC.

DESIGN CONSULTANT

PROFESSIONAL ENGINEERING

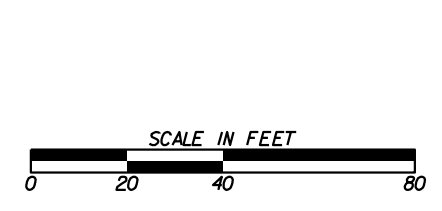

REVISION DATES	

SIGNING AND MARKING PLANS			
SR 369/BROWNS BRIDGE RD			
CHECKED:		DATE:	
BACKCHECKED:		DATE:	
CORRECTED:		DATE:	
VERIFIED:		DATE:	
DRAWING No.			26-0018

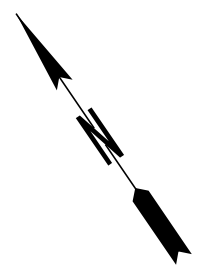
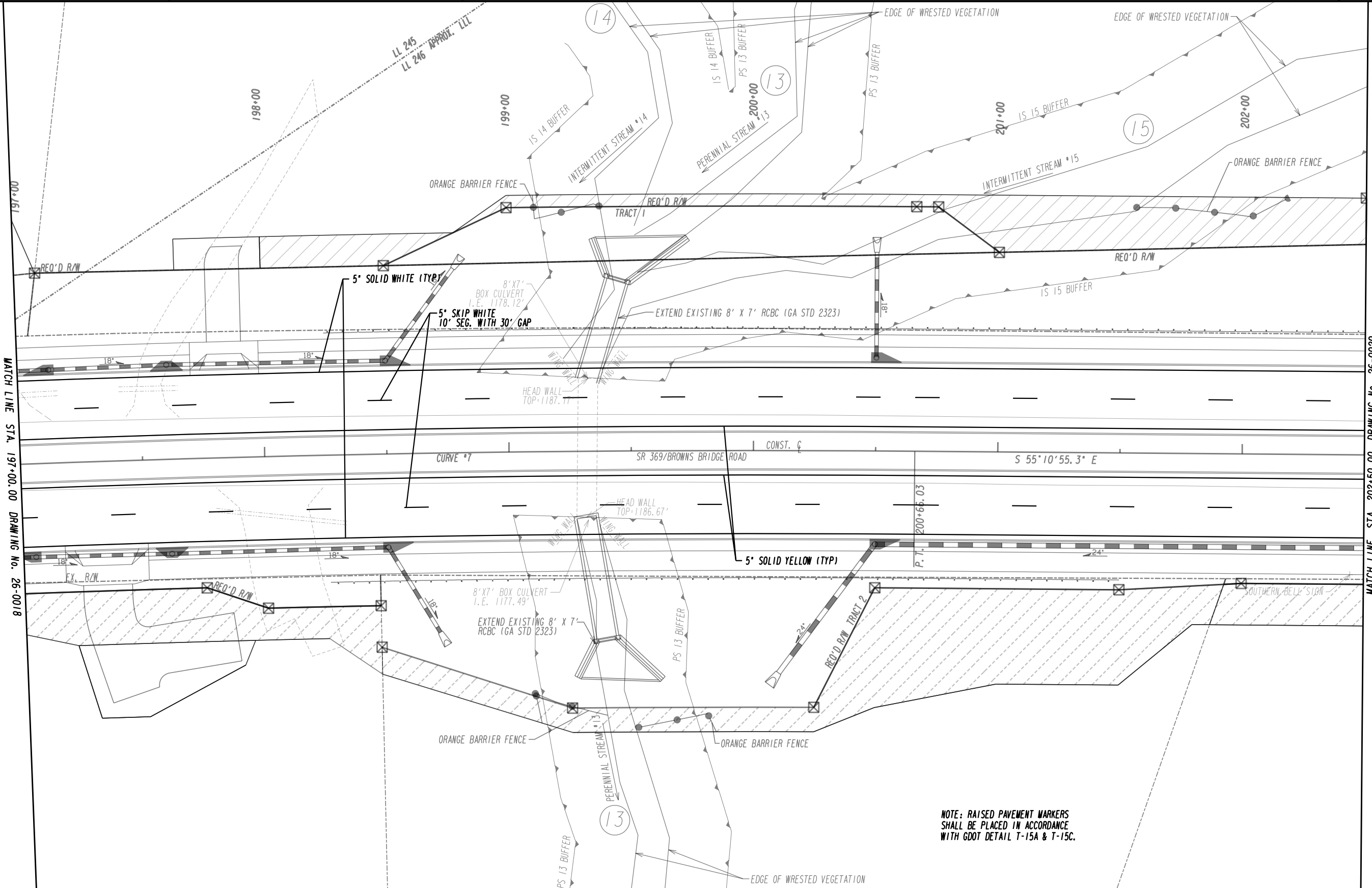

MATCH LINE STA. 197+00.00 DRAWING No. 26-0018

MATCH LINE STA. 202+50.00 DRAWING No. 26-0020

NOTE: RAISED PAVEMENT MARKERS SHALL BE PLACED IN ACCORDANCE WITH GDOT DETAIL T-15A & T-15C.

PROPERTY AND EXISTING R/W LINE	---
REQUIRED R/W LINE	---
CONSTRUCTION LIMITS	---
EASEMENT FOR CONSTR & MAINTENANCE OF SLOPES	---
EASEMENT FOR CONSTR OF SLOPES	---
EASEMENT FOR CONSTR OF DRIVES	---
PAVEMENT/MEDIAN REMOVAL	---

BEGIN LIMIT OF ACCESS.....BLA	---
END LIMIT OF ACCESS.....ELA	---
LIMIT OF ACCESS	---
REQ'D R/W & LIMIT OF ACCESS	---
ORANGE BARRIER FENCE	---
ESA - ENV. SENSITIVE AREA (SEE ERIT TABLE)	---

PLANS PREPARED AND SUBMITTED BY:
AEI
 AMERICAN ENGINEERS, INC.
 DESIGN CONSULTANT

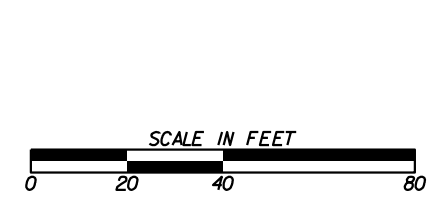

REVISION DATES	

SIGNING AND MARKING PLANS			
SR 369/BROWNS BRIDGE RD			
CHECKED:	DATE:	DRAWING No.	
BACKCHECKED:	DATE:	26-0019	
CORRECTED:	DATE:		
VERIFIED:	DATE:		

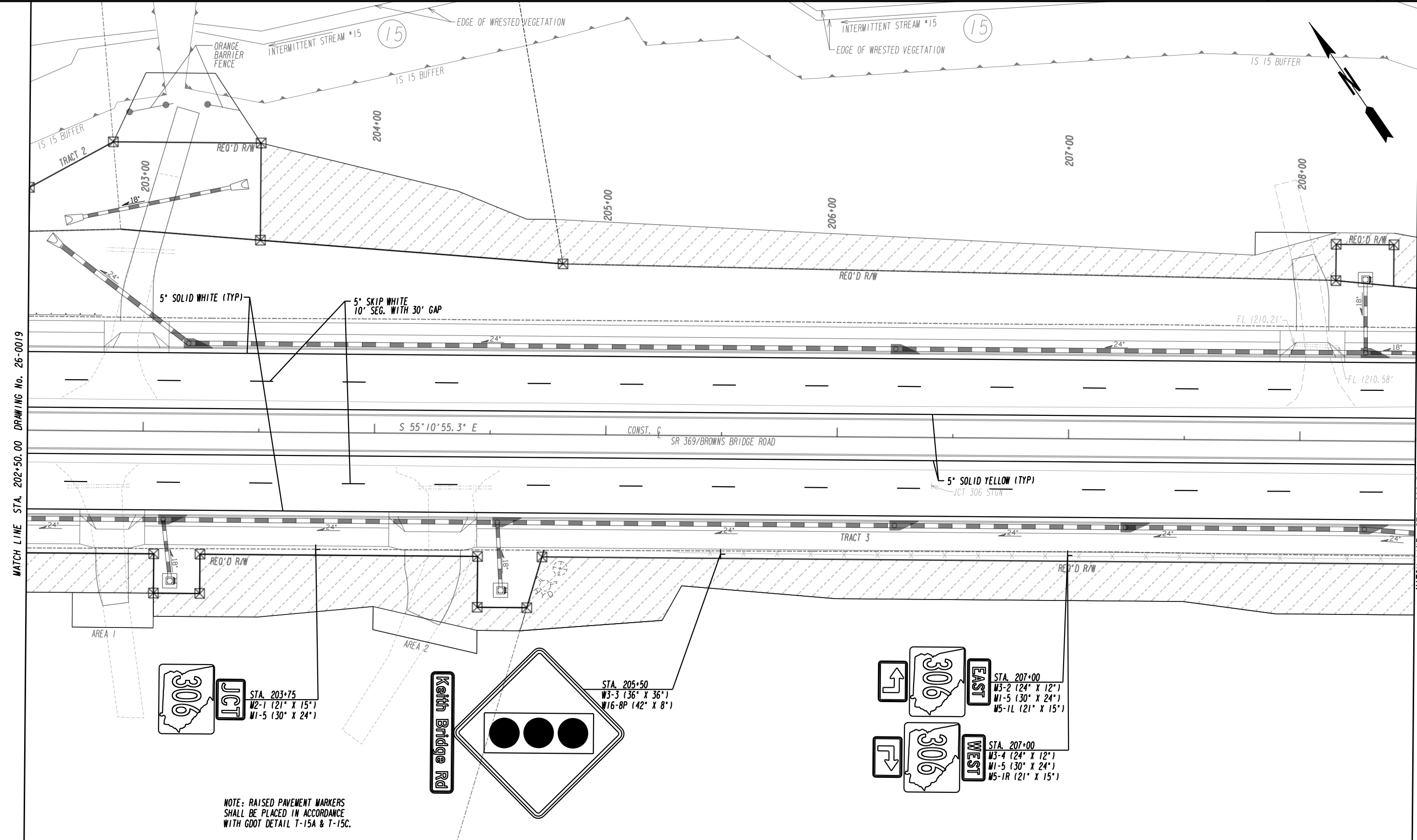

MATCH LINE STA. 202+50.00 DRAWING No. 26-0019

MATCH LINE STA. 208+50.00 DRAWING No. 26-0021

NOTE: RAISED PAVEMENT MARKERS SHALL BE PLACED IN ACCORDANCE WITH GDOT DETAIL T-15A & T-15C.

PROPERTY AND EXISTING R/W LINE
REQUIRED R/W LINE
CONSTRUCTION LIMITS
EASEMENT FOR CONSTR & MAINTENANCE OF SLOPES
EASEMENT FOR CONSTR OF SLOPES
EASEMENT FOR CONSTR OF DRIVES
PAVEMENT/MEDIAN REMOVAL

---	---
---	---
---	---
---	---
---	---
---	---
---	---
---	---

BEGIN LIMIT OF ACCESS.....BLA
END LIMIT OF ACCESS.....ELA
LIMIT OF ACCESS
REQ'D R/W & LIMIT OF ACCESS
ORANGE BARRIER FENCE
ESA - ENV. SENSITIVE AREA (SEE ERIT TABLE)

---	---
---	---
---	---
---	---
---	---
---	---

PLANS PREPARED AND SUBMITTED BY:

AEI
AMERICAN ENGINEERS, INC.
DESIGN CONSULTANT

PROFESSIONAL ENGINEERING

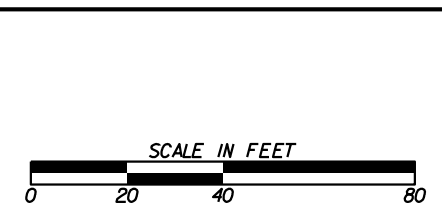

REVISION DATES

SIGNING AND MARKING PLANS

SR 369/BROWNS BRIDGE RD

CHECKED:		DATE:		DRAWING No.	
BACKCHECKED:		DATE:			
CORRECTED:		DATE:			
VERIFIED:		DATE:			

26-0020

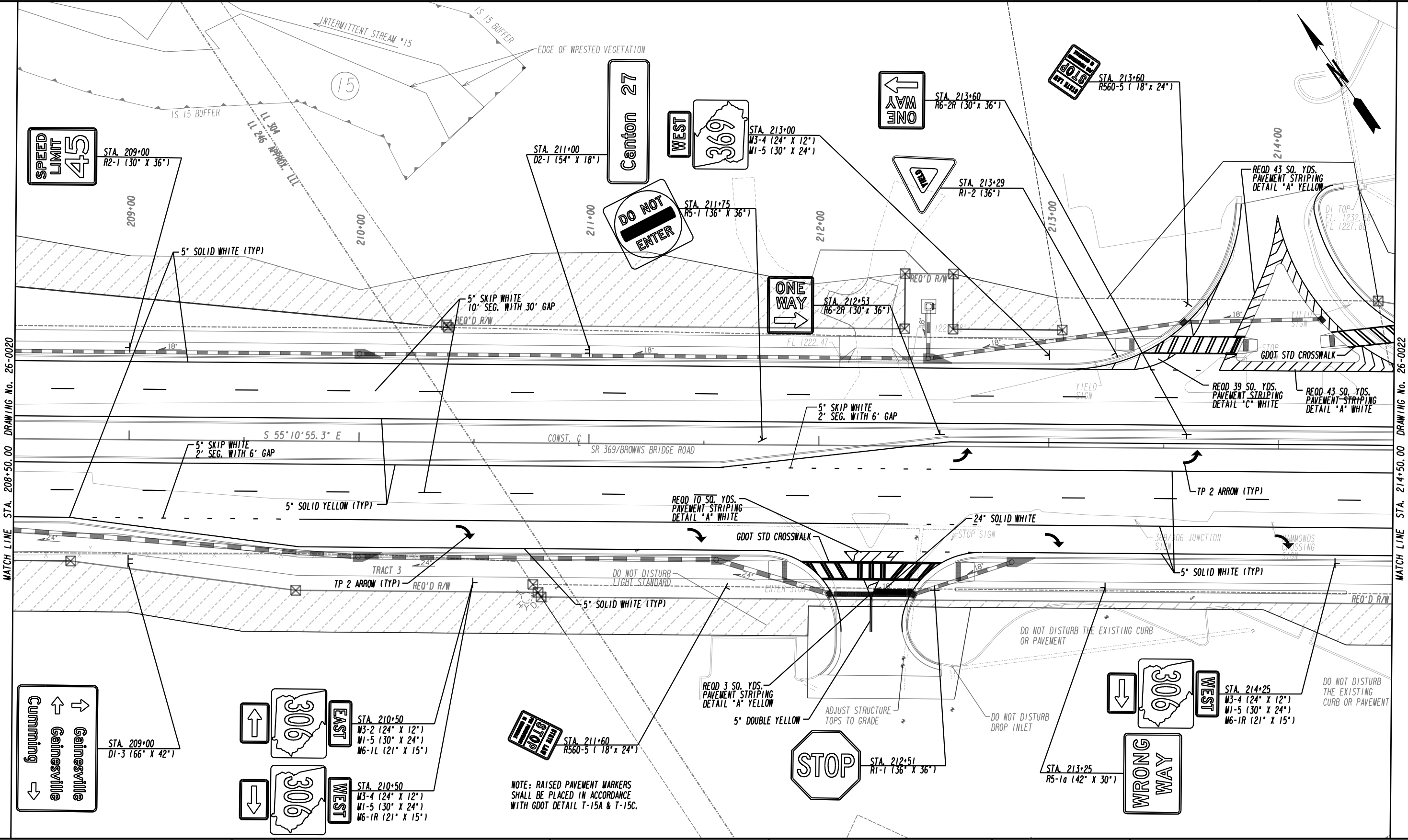

MATCH LINE STA. 208+50.00 DRAWING No. 26-0020

MATCH LINE STA. 214+50.00 DRAWING No. 26-0022

PROPERTY AND EXISTING R/W LINE
 REQUIRED R/W LINE
 CONSTRUCTION LIMITS
 EASEMENT FOR CONSTR
 & MAINTENANCE OF SLOPES
 EASEMENT FOR CONSTR OF SLOPES
 EASEMENT FOR CONSTR OF DRIVES
 PAVEMENT/MEDIAN REMOVAL

BEGIN LIMIT OF ACCESS.....BLA
 END LIMIT OF ACCESS.....ELA
 LIMIT OF ACCESS
 REQ'D R/W & LIMIT OF ACCESS
 ORANGE BARRIER FENCE
 ESA - ENV. SENSITIVE AREA
 (SEE ERIT TABLE)

PLANS PREPARED AND SUBMITTED BY:

AEI
 AMERICAN ENGINEERS, INC.
 www.aei.cc

DESIGN CONSULTANT

PROFESSIONAL ENGINEERING

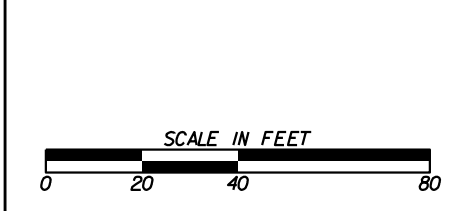

REVISION DATES

SIGNING AND MARKING PLANS

SR 369/BROWNS BRIDGE RD

CHECKED:		DATE:		DRAWING No.	
BACKCHECKED:		DATE:			
CORRECTED:		DATE:			
VERIFIED:		DATE:			

26-0021

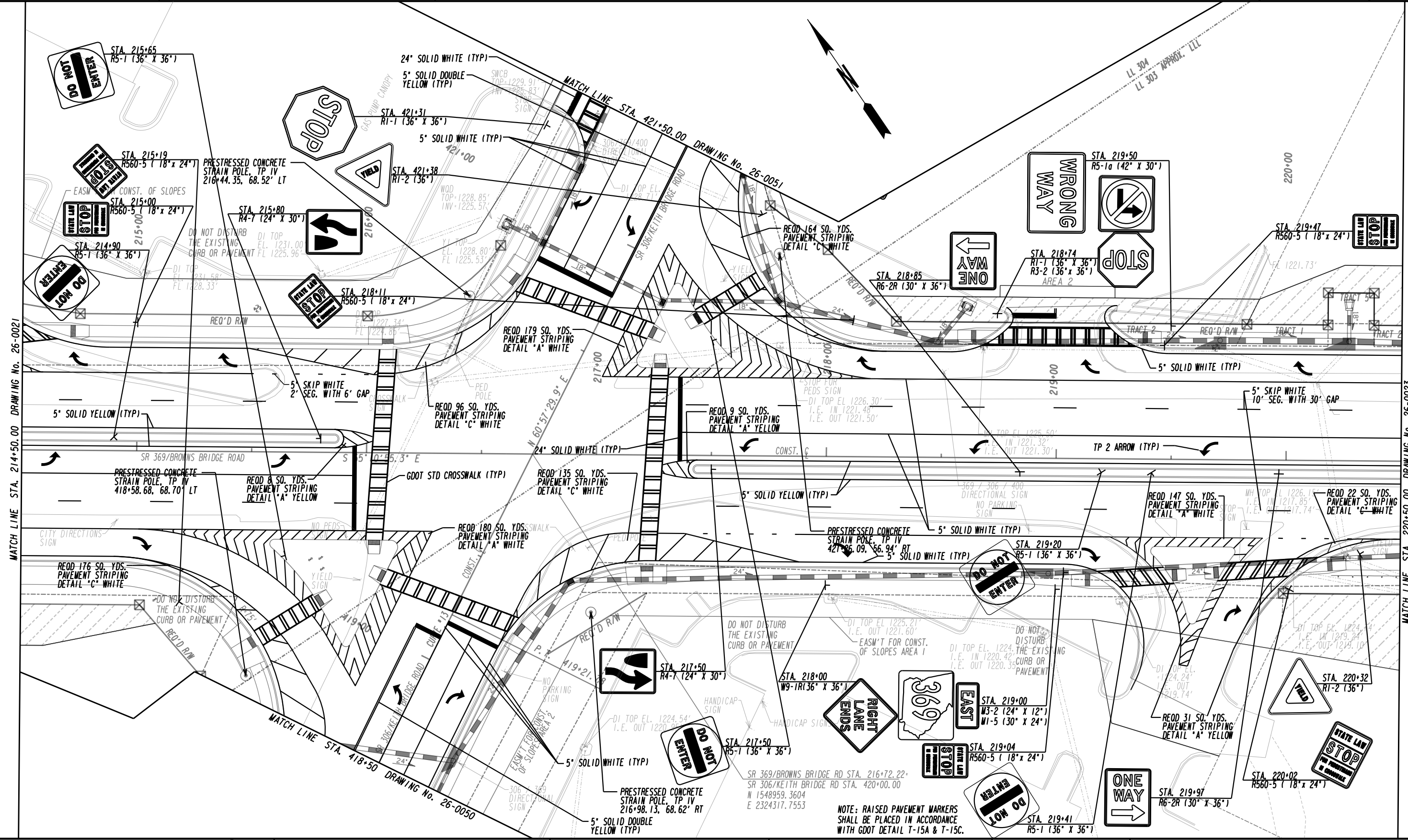

PROPERTY AND EXISTING R/W LINE
 REQUIRED R/W LINE
 CONSTRUCTION LIMITS
 EASEMENT FOR CONSTR
 & MAINTENANCE OF SLOPES
 EASEMENT FOR CONSTR OF SLOPES
 EASEMENT FOR CONSTR OF DRIVES
 PAVEMENT/MEDIAN REMOVAL

BEGIN LIMIT OF ACCESS.....BLA
 END LIMIT OF ACCESS.....ELA
 LIMIT OF ACCESS
 REQ'D R/W & LIMIT OF ACCESS
 ORANGE BARRIER FENCE
 ESA - ENV. SENSITIVE AREA
 (SEE ERIT TABLE)

PLANS PREPARED AND SUBMITTED BY:

AEI
 AMERICAN ENGINEERS, INC.
 www.aei.co

DESIGN CONSULTANT

PROFESSIONAL ENGINEERING

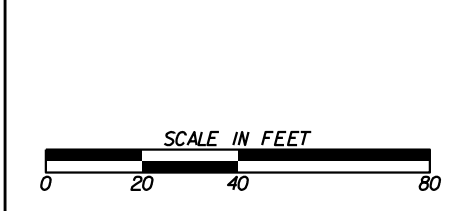

REVISION DATES

NO.	DATE	DESCRIPTION

SIGNING AND MARKING PLANS

SR 369/BROWNS BRIDGE RD
 SR 306/KEITH BRIDGE RD

CHECKED:	DATE:	DRAWING No.
BACKCHECKED:	DATE:	26-0022
CORRECTED:	DATE:	
VERIFIED:	DATE:	

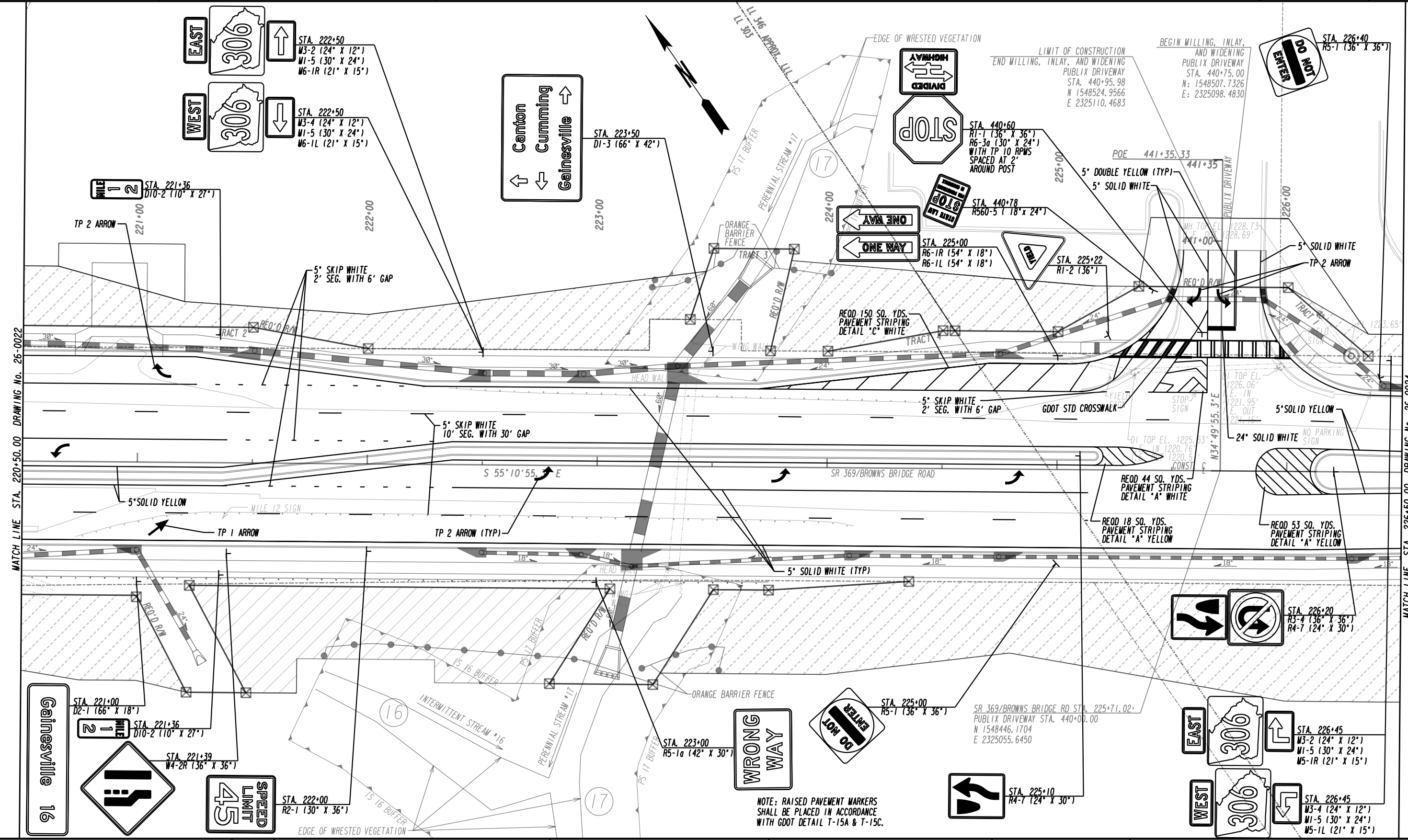

MATCH LINE STA. 220+50.00 DRAWING No. 26-0022

MATCH LINE STA. 226+50.00 DRAWING No. 26-0024

PROPERTY AND EXISTING R/W LINE	-----e-----
REQUIRED R/W LINE	-----f-----
CONSTRUCTION LIMITS	-----g-----
EASEMENT FOR CONSTR & MAINTENANCE OF SLOPES	-----h-----
EASEMENT FOR CONSTR OF SLOPES	-----i-----
EASEMENT FOR CONSTR OF DRIVES	-----j-----
PAVEMENT/MEDIAN REMOVAL	-----k-----

BEGIN LIMIT OF ACCESS.....BLA	-----l-----
END LIMIT OF ACCESS.....ELA	-----m-----
LIMIT OF ACCESS	-----n-----
REQ'D R/W & LIMIT OF ACCESS	-----o-----
ORANGE BARRIER FENCE	-----p-----
ESA - ENV. SENSITIVE AREA (SEE ERIT TABLE)	-----q-----

PLANS PREPARED AND SUBMITTED BY:

AET

65 Aberdeen Drive
Cincinnati, KY 45241
(270) 651-7220

2500 Nelson Miller Parkway
Louisville, KY 40223
(502) 245-3813

634 White Circle, Suite 101
Morgantown, GA 30056
(770) 421-8422

AMERICAN ENGINEERS, INC.
www.aei.cc

DESIGN CONSULTANT PROFESSIONAL ENGINEERING

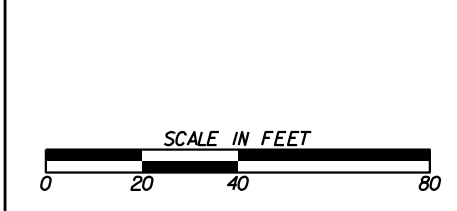

REVISION DATES	

SIGNING AND MARKING PLANS		
SR 369/BROWNS BRIDGE RD		
CHECKED:	DATE:	DRAWING No.
BACKCHECKED:	DATE:	26-0023
CORRECTED:	DATE:	
VERIFIED:	DATE:	

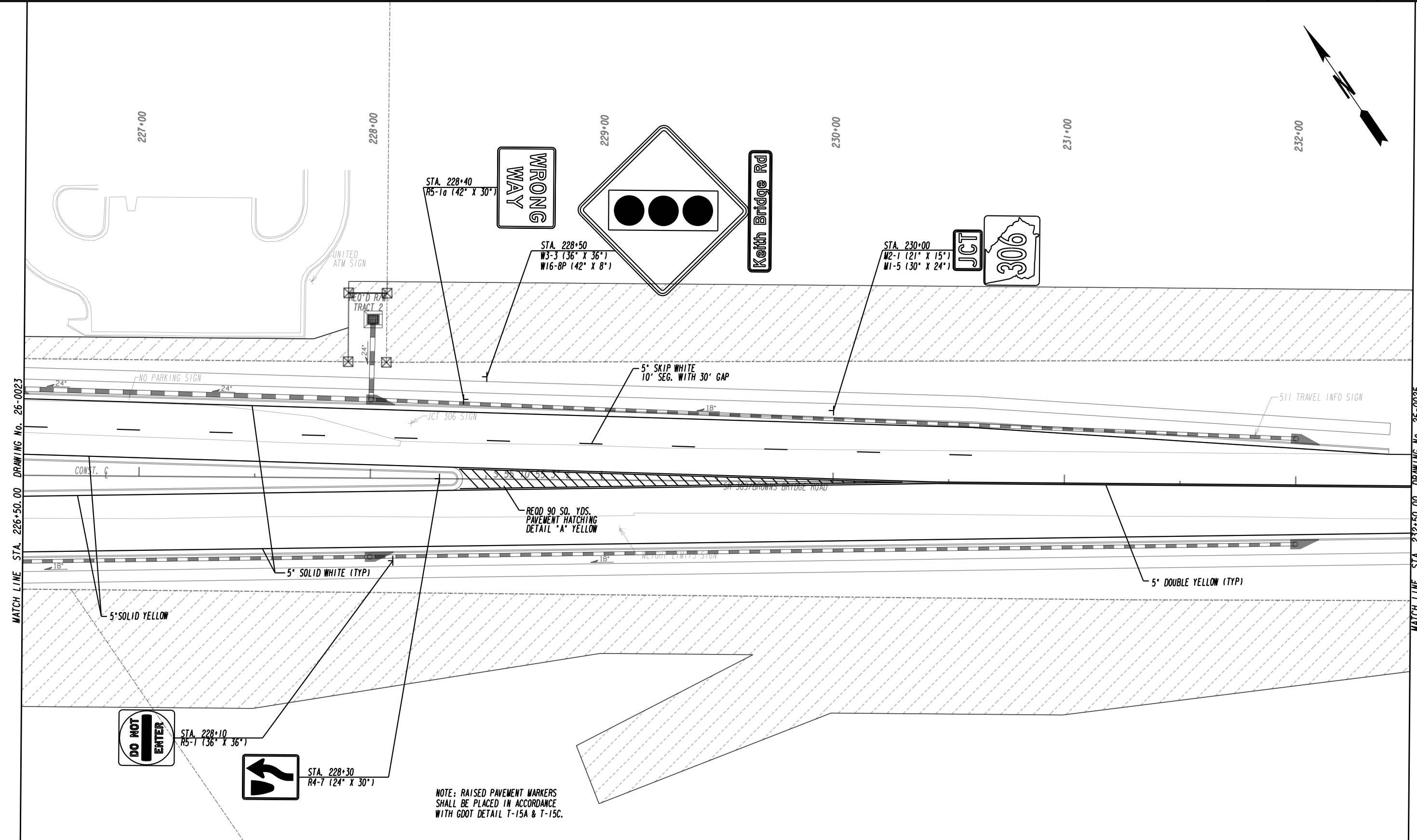
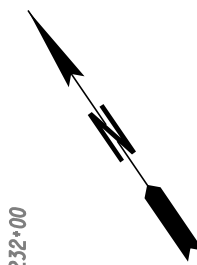

MATCH LINE STA. 226+50.00 DRAWING No. 26-0023

MATCH LINE STA. 232+50.00 DRAWING No. 26-0025



STA. 228+10
R5-1 (36" X 36")



STA. 228+30
R4-7 (24" X 30")

NOTE: RAISED PAVEMENT MARKERS SHALL BE PLACED IN ACCORDANCE WITH GDOT DETAIL T-15A & T-15C.

PROPERTY AND EXISTING R/W LINE	---
REQUIRED R/W LINE	---
CONSTRUCTION LIMITS	---
EASEMENT FOR CONSTR & MAINTENANCE OF SLOPES	---
EASEMENT FOR CONSTR OF SLOPES	---
EASEMENT FOR CONSTR OF DRIVES	---
PAVEMENT/MEDIAN REMOVAL	---

BEGIN LIMIT OF ACCESS.....BLA	---
END LIMIT OF ACCESS.....ELA	---
LIMIT OF ACCESS	---
REQ'D R/W & LIMIT OF ACCESS	---
ORANGE BARRIER FENCE	---
ESA - ENV. SENSITIVE AREA (SEE ERIT TABLE)	---

PLANS PREPARED AND SUBMITTED BY:

AEI
AMERICAN ENGINEERS, INC.
DESIGN CONSULTANT

Branch Office:
65 Aberdeen Drive
Cincinnati, KY 45241
(270) 651-7220

2500 Nelson Miller Parkway
Louisville, KY 40223
(502) 245-3813

Branch Office:
1634 White Circle, Suite 101
Mableton, GA 30056
(770) 421-8422

PROFESSIONAL ENGINEERING

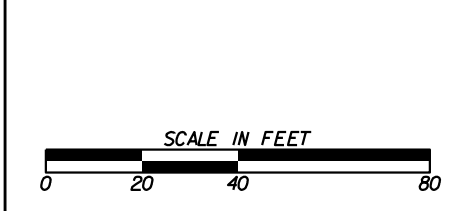

REVISION DATES	

SIGNING AND MARKING PLANS		
SR 369/BROWNS BRIDGE RD		
CHECKED:	DATE:	DRAWING No.
BACKCHECKED:	DATE:	26-0024
CORRECTED:	DATE:	
VERIFIED:	DATE:	

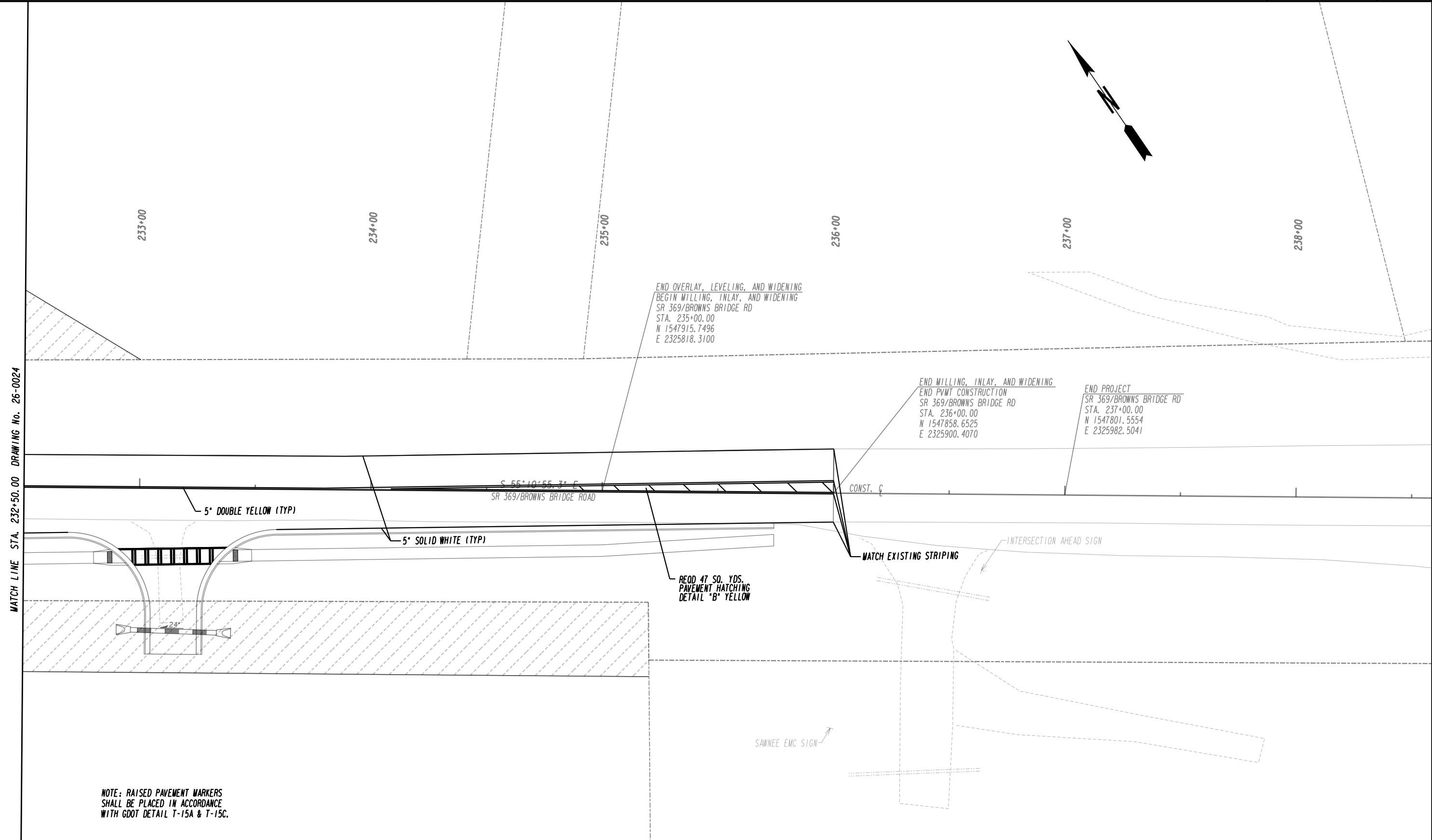

MATCH LINE STA. 232+50.00 DRAWING No. 26-0024

NOTE: RAISED PAVEMENT MARKERS SHALL BE PLACED IN ACCORDANCE WITH GDOT DETAIL T-15A & T-15C.

PROPERTY AND EXISTING R/W LINE	---
REQUIRED R/W LINE	---
CONSTRUCTION LIMITS	---
EASEMENT FOR CONSTR & MAINTENANCE OF SLOPES	---/---
EASEMENT FOR CONSTR OF SLOPES	---/---
EASEMENT FOR CONSTR OF DRIVES	---/---
PAVEMENT/MEDIAN REMOVAL	---/---

BEGIN LIMIT OF ACCESS.....BLA	--- ---
END LIMIT OF ACCESS.....ELA	--- ---
LIMIT OF ACCESS	--- ---
REQ'D R/W & LIMIT OF ACCESS	--- ---
ORANGE BARRIER FENCE	--- ---
ESA - ENV. SENSITIVE AREA (SEE ERIT TABLE)	--- ---

PLANS PREPARED AND SUBMITTED BY:

AEI
AMERICAN ENGINEERS, INC.
DESIGN CONSULTANT

PROFESSIONAL ENGINEERING

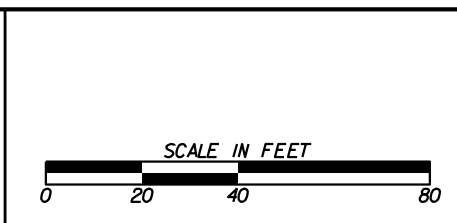

REVISION DATES	

SIGNING AND MARKING PLANS			
SR 369/BROWNS BRIDGE RD			
CHECKED:		DATE:	
BACKCHECKED:		DATE:	
CORRECTED:		DATE:	
VERIFIED:		DATE:	
DRAWING No.			26-0025

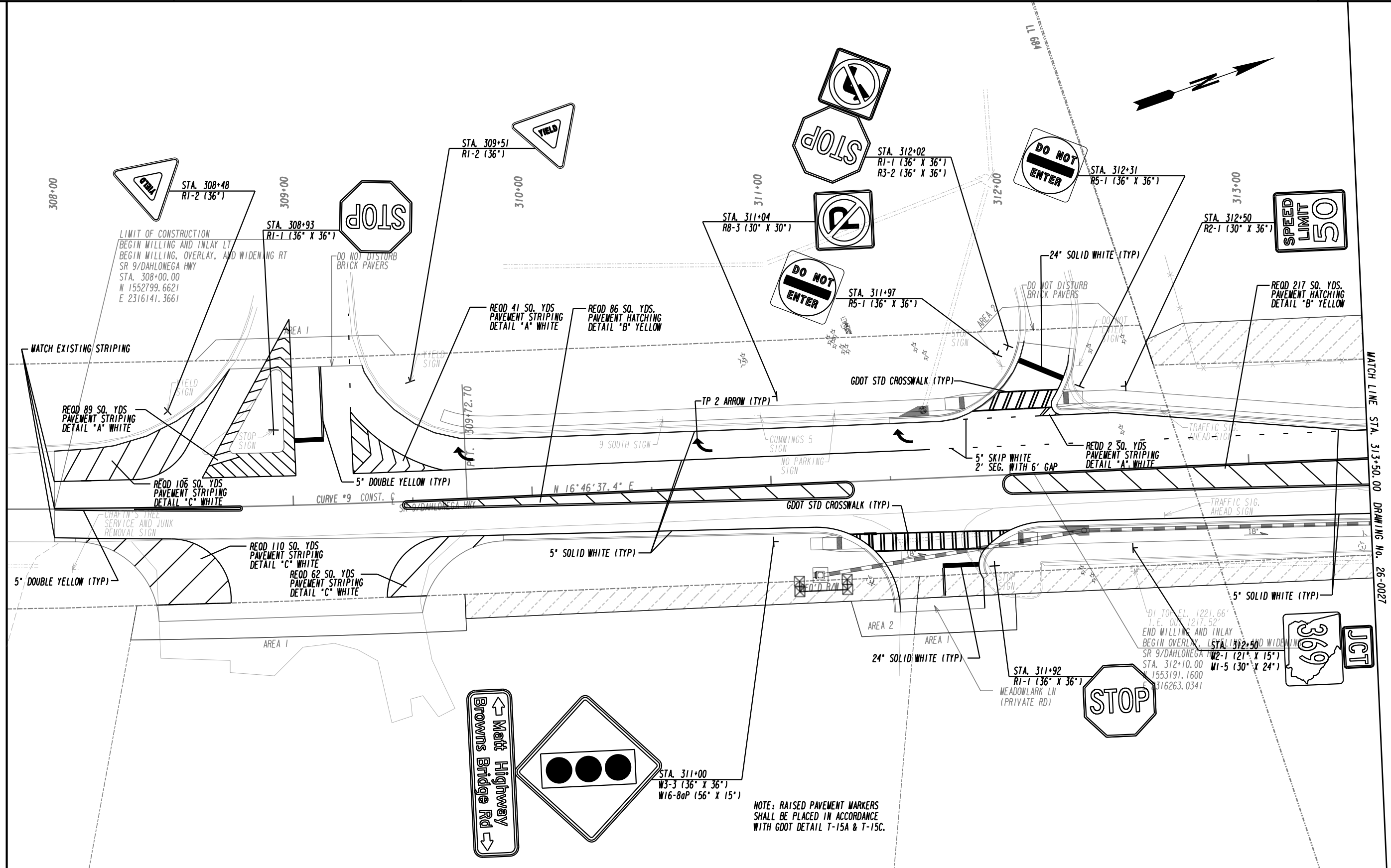

PROPERTY AND EXISTING R/W LINE
REQUIRED R/W LINE
CONSTRUCTION LIMITS
EASEMENT FOR CONSTR
& MAINTENANCE OF SLOPES
EASEMENT FOR CONSTR OF SLOPES
EASEMENT FOR CONSTR OF DRIVES
PAVEMENT/MEDIAN REMOVAL

---	---
---	---
---	---
---	---
---	---
---	---
---	---
---	---
---	---
---	---

BEGIN LIMIT OF ACCESS.....BLA
END LIMIT OF ACCESS.....ELA
LIMIT OF ACCESS
REQ'D R/W & LIMIT OF ACCESS
ORANGE BARRIER FENCE
ESA - ENV. SENSITIVE AREA
(SEE ERIT TABLE)

---	---
---	---
---	---
---	---
---	---
---	---
---	---
---	---
---	---
---	---

PLANS PREPARED AND SUBMITTED BY:

AEI
AMERICAN ENGINEERS, INC.
www.aei.cc

DESIGN CONSULTANT
PROFESSIONAL ENGINEERING

65 Aberdeen Drive
Cincinnati, KY 45241
(270) 651-7220

634 White Circle, Suite 101
Mableton, GA 30056
(770) 421-8422

2500 Nelson Miller Parkway
Louisville, KY 40223
(502) 245-3813

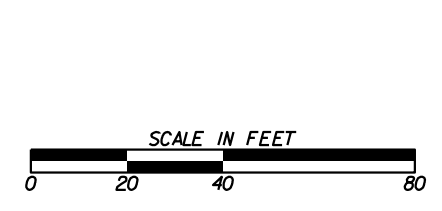

REVISION DATES

SIGNING AND MARKING PLANS

SR 9/DAHLONEGA HWY

CHECKED:		DATE:		DRAWING No.	
BACKCHECKED:		DATE:			
CORRECTED:		DATE:			
VERIFIED:		DATE:			

26-0026

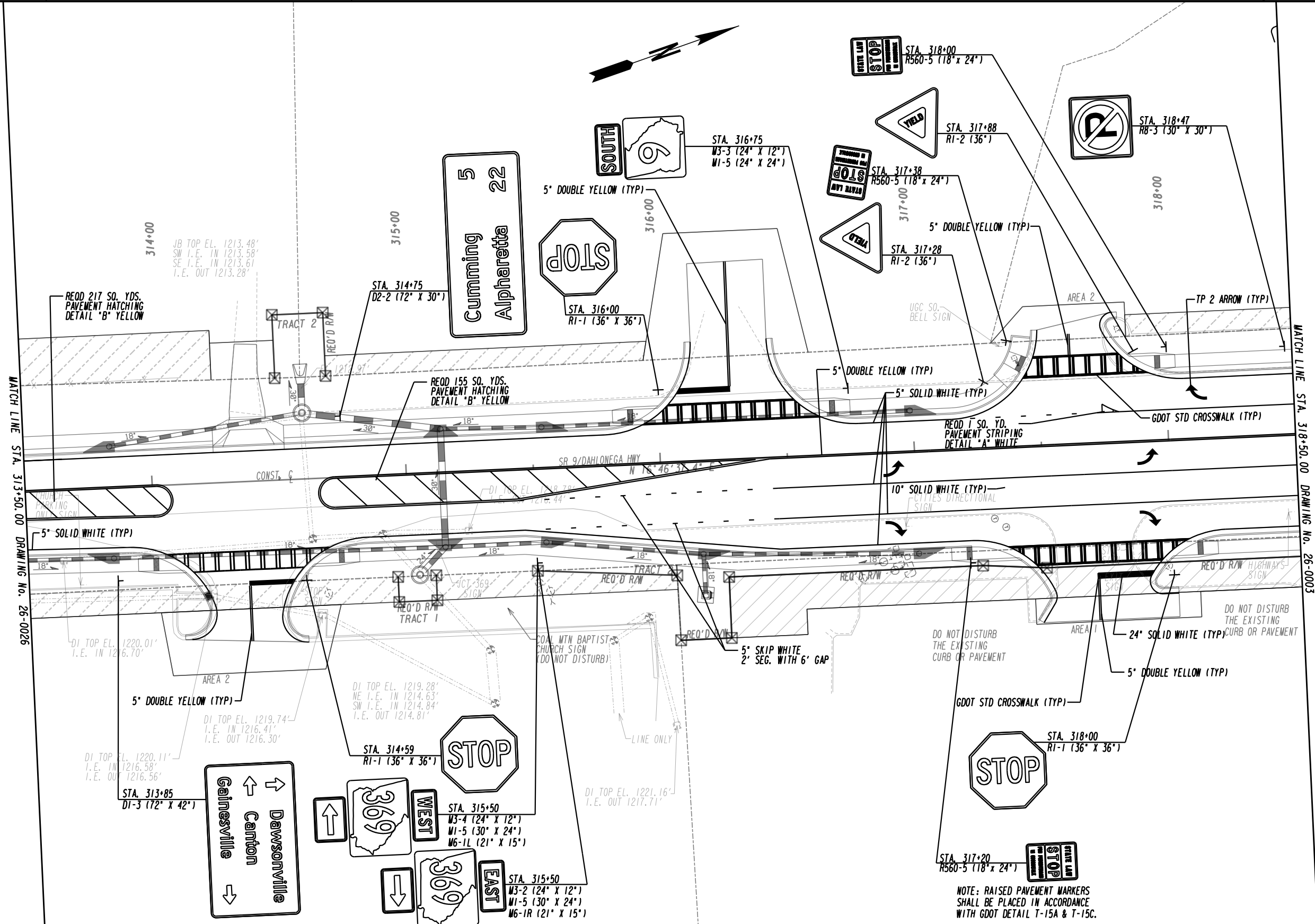

PROPERTY AND EXISTING R/W LINE	---
REQUIRED R/W LINE	---
CONSTRUCTION LIMITS	---
EASEMENT FOR CONSTR & MAINTENANCE OF SLOPES	---
EASEMENT FOR CONSTR OF SLOPES	---
EASEMENT FOR CONSTR OF DRIVES	---
PAVEMENT/MEDIAN REMOVAL	---

BEGIN LIMIT OF ACCESS.....BLA	---
END LIMIT OF ACCESS.....ELA	---
LIMIT OF ACCESS	---
REQ'D R/W & LIMIT OF ACCESS	---
ORANGE BARRIER FENCE	---
ESA - ENV. SENSITIVE AREA (SEE ERIT TABLE)	---

PLANS PREPARED AND SUBMITTED BY:

AEI
AMERICAN ENGINEERS, INC.
www.aei.cc

DESIGN CONSULTANT

PROFESSIONAL ENGINEERING

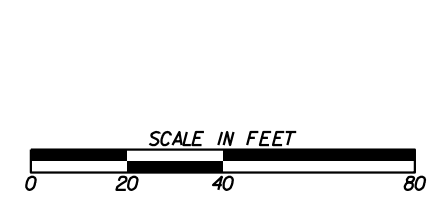

REVISION DATES	

SIGNING AND MARKING PLANS			
SR 9/DAHLONEGA HWY			
CHECKED:	DATE:	DRAWING No.	
BACKCHECKED:	DATE:	26-0027	
CORRECTED:	DATE:		
VERIFIED:	DATE:		

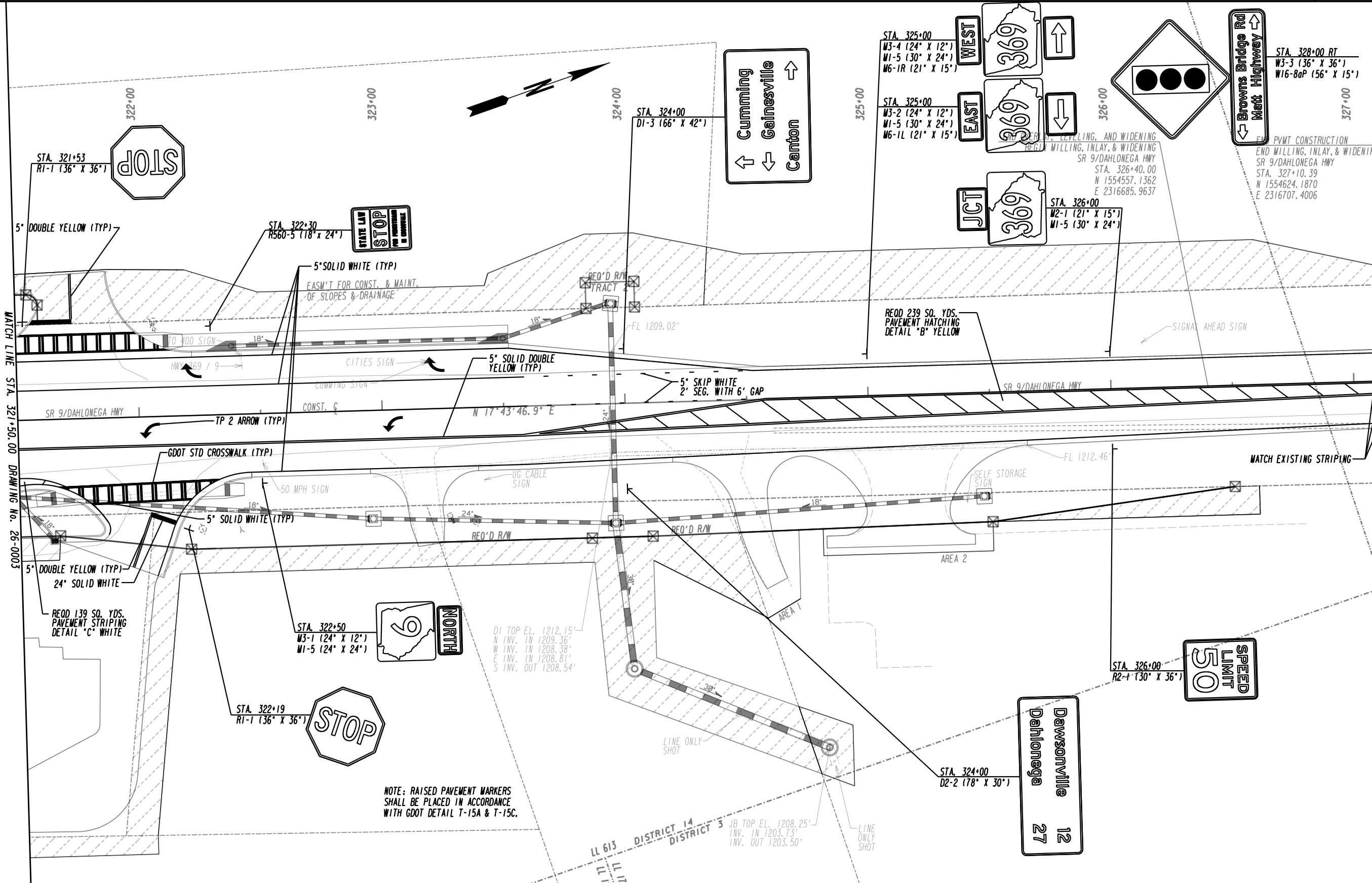

LIMIT OF CONSTRUCTION
SR 9/DAHLONEGA HWY
STA. 328+00.00
N 1554709.5368
E 2316734.6880

LIMIT OF SIGNAGE
SR 9/DAHLONEGA HWY
STA. 328+00.00

PROPERTY AND EXISTING R/W LINE	---
REQUIRED R/W LINE	---
CONSTRUCTION LIMITS	---
EASEMENT FOR CONSTR & MAINTENANCE OF SLOPES	---
EASEMENT FOR CONSTR OF SLOPES	---
EASEMENT FOR CONSTR OF DRIVES	---
PAVEMENT/MEDIAN REMOVAL	---

BEGIN LIMIT OF ACCESS.....BLA	---
END LIMIT OF ACCESS.....ELA	---
LIMIT OF ACCESS	---
REQ'D R/W & LIMIT OF ACCESS	---
ORANGE BARRIER FENCE	---
ESA - ENV. SENSITIVE AREA (SEE ERIT TABLE)	---

PLANS PREPARED AND SUBMITTED BY:

AEI

AMERICAN ENGINEERS, INC.

DESIGN CONSULTANT

PROFESSIONAL ENGINEERING

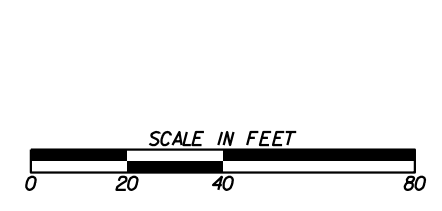

REVISION DATES	

SIGNING AND MARKING PLANS			
SR 9/DAHLONEGA HWY			
CHECKED:	DATE:	DRAWING No.	
BACKCHECKED:	DATE:	26-0028	
CORRECTED:	DATE:		
VERIFIED:	DATE:		

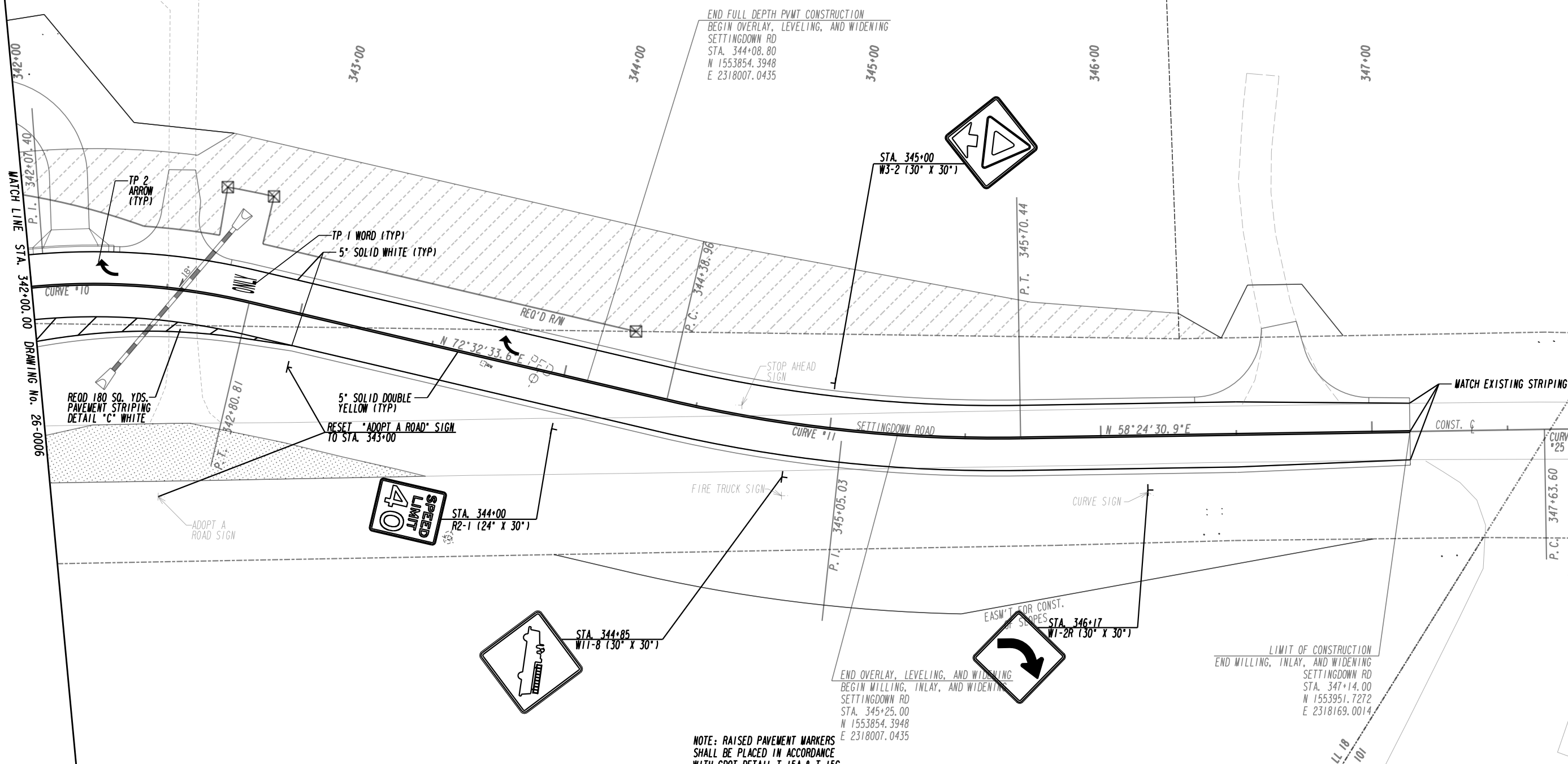
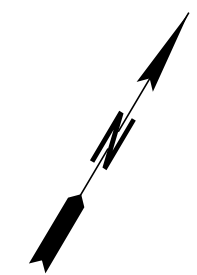

PROPERTY AND EXISTING R/W LINE	---
REQUIRED R/W LINE	---
CONSTRUCTION LIMITS	---
EASEMENT FOR CONSTR & MAINTENANCE OF SLOPES	---
EASEMENT FOR CONSTR OF SLOPES	---
EASEMENT FOR CONSTR OF DRIVES	---
PAVEMENT/MEDIAN REMOVAL	---

BEGIN LIMIT OF ACCESS.....BLA	---
END LIMIT OF ACCESS.....ELA	---
LIMIT OF ACCESS	---
REQ'D R/W & LIMIT OF ACCESS	---
ORANGE BARRIER FENCE	---
ESA - ENV. SENSITIVE AREA (SEE ERIT TABLE)	---

PLANS PREPARED AND SUBMITTED BY:

AEI

AMERICAN ENGINEERS, INC.

DESIGN CONSULTANT

PROFESSIONAL ENGINEERING

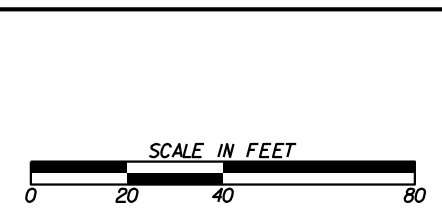

REVISION DATES	

SIGNING AND MARKING PLANS		
SETTINGDOWN RD		
CHECKED:	DATE:	DRAWING No.
BACKCHECKED:	DATE:	26-0029
CORRECTED:	DATE:	
VERIFIED:	DATE:	

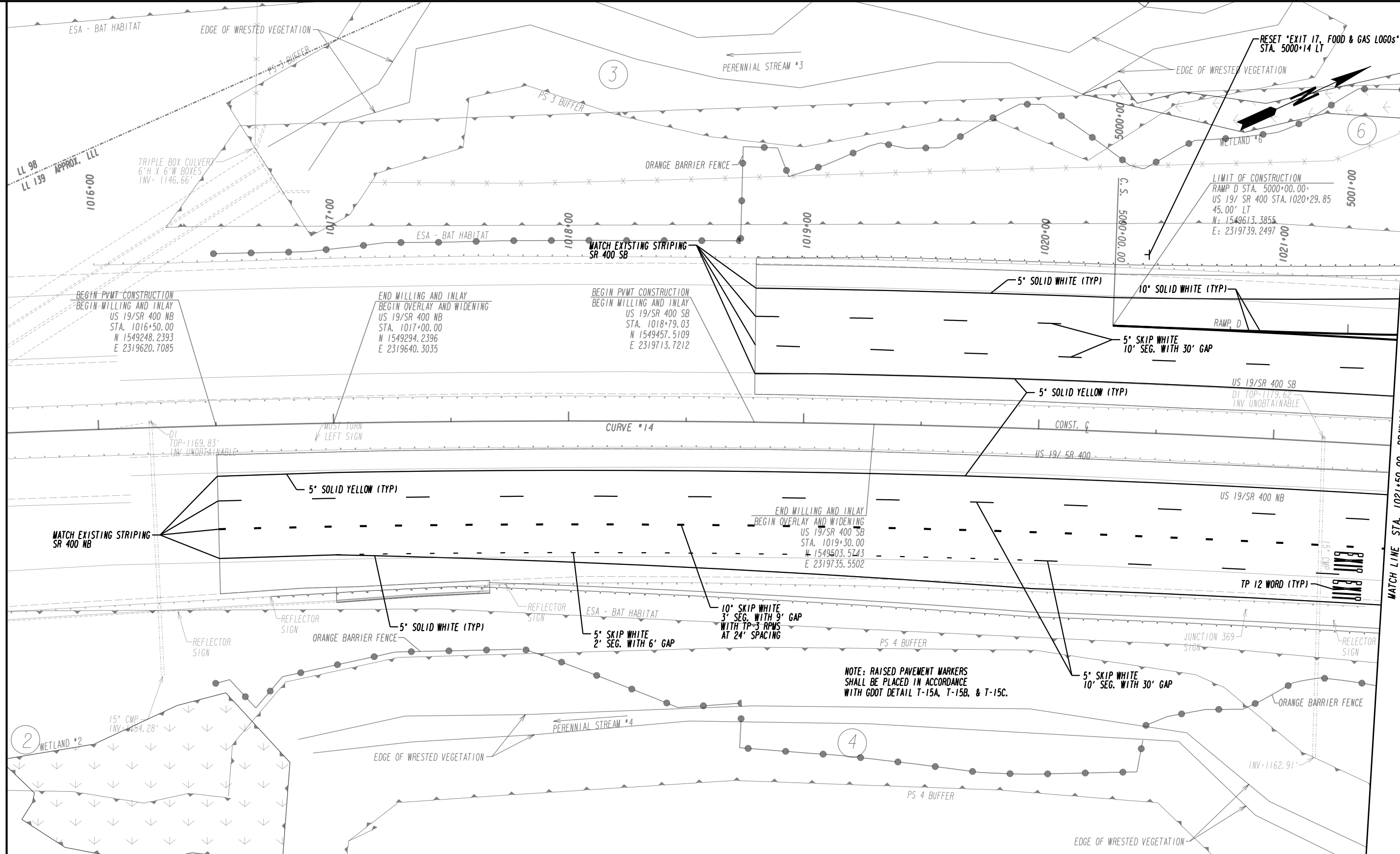

MATCH LINE STA. 1021+50.00 DRAWING No. 26-0031

PROPERTY AND EXISTING R/W LINE	---
REQUIRED R/W LINE	---
CONSTRUCTION LIMITS	---
EASEMENT FOR CONSTR & MAINTENANCE OF SLOPES	---
EASEMENT FOR CONSTR OF SLOPES	---
EASEMENT FOR CONSTR OF DRIVES	---
PAVEMENT/MEDIAN REMOVAL	---

BEGIN LIMIT OF ACCESS.....BLA	---
END LIMIT OF ACCESS.....ELA	---
LIMIT OF ACCESS	---
REQ'D R/W & LIMIT OF ACCESS	---
ORANGE BARRIER FENCE	---
ESA - ENV. SENSITIVE AREA (SEE ERIT TABLE)	---

PLANS PREPARED AND SUBMITTED BY:

AEI

2500 Nelson Miller Parkway
Louisville, KY 40223
502.245.3813
www.aei.cc

DESIGN CONSULTANT

PROFESSIONAL ENGINEERING

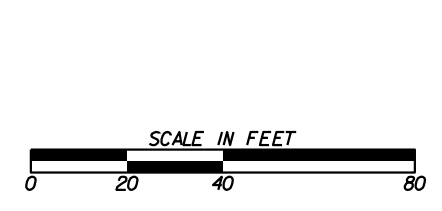

REVISION DATES	

SIGNING AND MARKING PLANS			
SR 400/US 19			
CHECKED:		DATE:	
BACKCHECKED:		DATE:	
CORRECTED:		DATE:	
VERIFIED:		DATE:	
DRAWING No.			26-0030

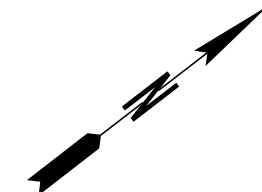
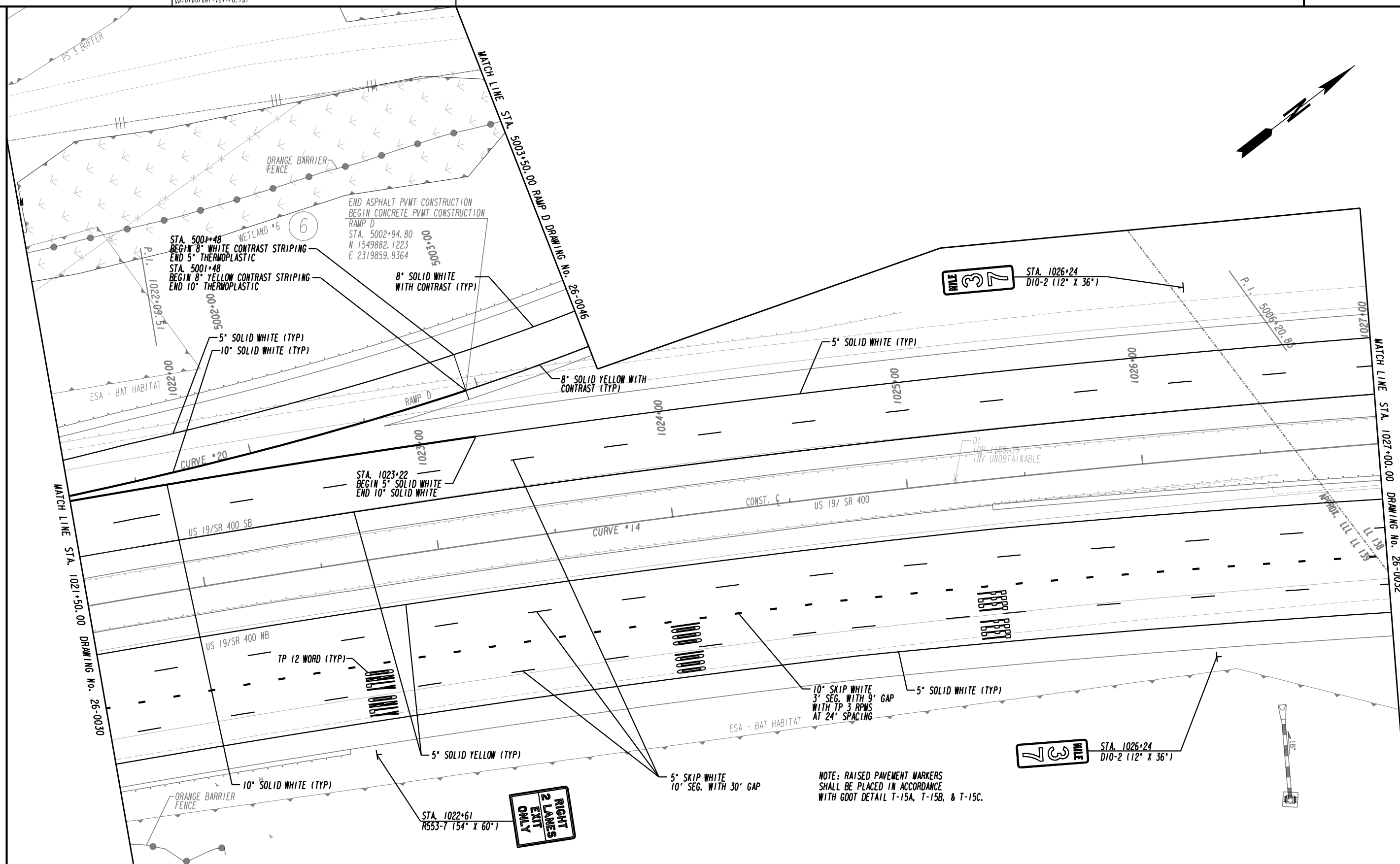

PROPERTY AND EXISTING R/W LINE
REQUIRED R/W LINE
CONSTRUCTION LIMITS
EASEMENT FOR CONSTR
& MAINTENANCE OF SLOPES
EASEMENT FOR CONSTR OF SLOPES
EASEMENT FOR CONSTR OF DRIVES
PAVEMENT/MEDIAN REMOVAL

BEGIN LIMIT OF ACCESS.....BLA
END LIMIT OF ACCESS.....ELA
LIMIT OF ACCESS
REQ'D R/W & LIMIT OF ACCESS
ORANGE BARRIER FENCE
ESA - ENV. SENSITIVE AREA
(SEE ERIT TABLE)

PLANS PREPARED AND SUBMITTED BY:

AEI
AMERICAN ENGINEERS, INC.
DESIGN CONSULTANT

PROFESSIONAL ENGINEERING

Branch Office:
65 Aberdeen Drive
Cincinnati, KY 45241
(270) 651-7220

2500 Nelson Miller Parkway
Louisville, KY 40223
(502) 245-3813

634 White Circle, Suite 101
Marietta, GA 30066
(770) 421-8422

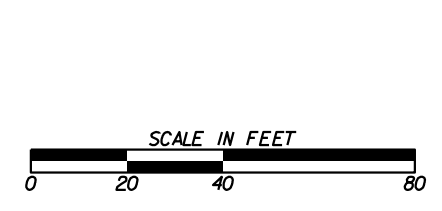

REVISION DATES

NO.	DATE	DESCRIPTION

SIGNING AND MARKING PLANS

SR 400/US 19

CHECKED:	DATE:	DRAWING No.
BACKCHECKED:	DATE:	26-0031
CORRECTED:	DATE:	
VERIFIED:	DATE:	



STA. 1028+22
W4-3 (48' x 48')

RESET
"EXIT 17, GA 306, 1/2 MILE" SIGN
TO STA. 1027+80

MATCH LINE DRAWING No. 26-0044

MATCH LINE DRAWING No. 26-0044

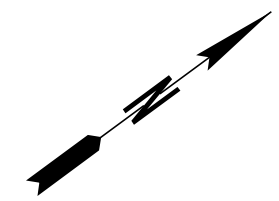

MATCH LINE STA. 1027+00.00 DRAWING No. 26-0031

MATCH LINE STA. 1032+00.00 DRAWING No. 26-0033

US 19/SR 400 SB

US 19/SR 400 NB

DI. TOP=1193.11'
INV UNOBTAINABLE

CURVE *14 US 19/ SR 400 CONST. C

TRAFFIC SIGNAL AHEAD
W/ FLASHING LIGHT
SIGN

5" SKIP WHITE
10' SEG. WITH 30' GAP

5" SOLID WHITE (TYP)

5" SOLID YELLOW (TYP)

TRAFFIC SIGNAL AHEAD
W/ FLASHING LIGHT
SIGN

10" SKIP WHITE
3' SEG. WITH 9' GAP
WITH TP 3 RPWS
AT 24' SPACING

RESET
"FORSYTH CO. FIRE DEPARTMENT" SIGN
TO STA. 1029+93

EAST 369
SIGN

WEST 369
SIGN

APPROX. L.L. T-15B

ESA - BAT HABITAT

NOTE: RAISED PAVEMENT MARKERS
SHALL BE PLACED IN ACCORDANCE
WITH GDOT DETAIL T-15A, T-15B, & T-15C.

PROPERTY AND EXISTING R/W LINE
REQUIRED R/W LINE
CONSTRUCTION LIMITS
EASEMENT FOR CONSTR
& MAINTENANCE OF SLOPES
EASEMENT FOR CONSTR OF SLOPES
EASEMENT FOR CONSTR OF DRIVES
PAVEMENT/MEDIAN REMOVAL

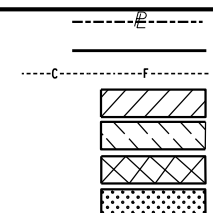

BEGIN LIMIT OF ACCESS.....BLA
END LIMIT OF ACCESS.....ELA
LIMIT OF ACCESS
REQ'D R/W & LIMIT OF ACCESS
ORANGE BARRIER FENCE
ESA - ENV. SENSITIVE AREA
(SEE ERIT TABLE)

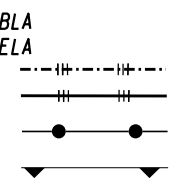

PLANS PREPARED AND SUBMITTED BY:
Branch Office
O 65 Aberdeen Drive
Glasgow, KY 40304
(270) 651-7220
O 2500 Nelson Miller Parkway
Louisville, KY 40223
(502) 245-3813
www.aei.cc
AMERICAN ENGINEERS, INC.
DESIGN CONSULTANT
PROFESSIONAL ENGINEERING
O 634 White Circle, Suite 101
Mableton, GA 30056
(770) 421-8422

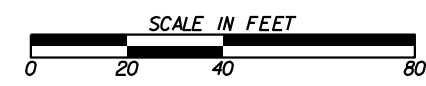

REVISION DATES

NO.	DATE	DESCRIPTION

SIGNING AND MARKING PLANS

SR 400/US 19

CHECKED:	DATE:	DRAWING No.
		26-0032
BACKCHECKED:	DATE:	
CORRECTED:	DATE:	
VERIFIED:	DATE:	

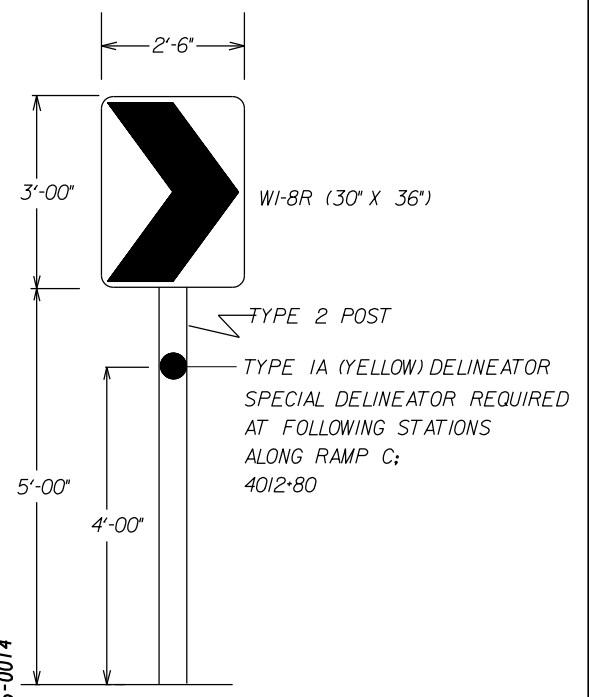
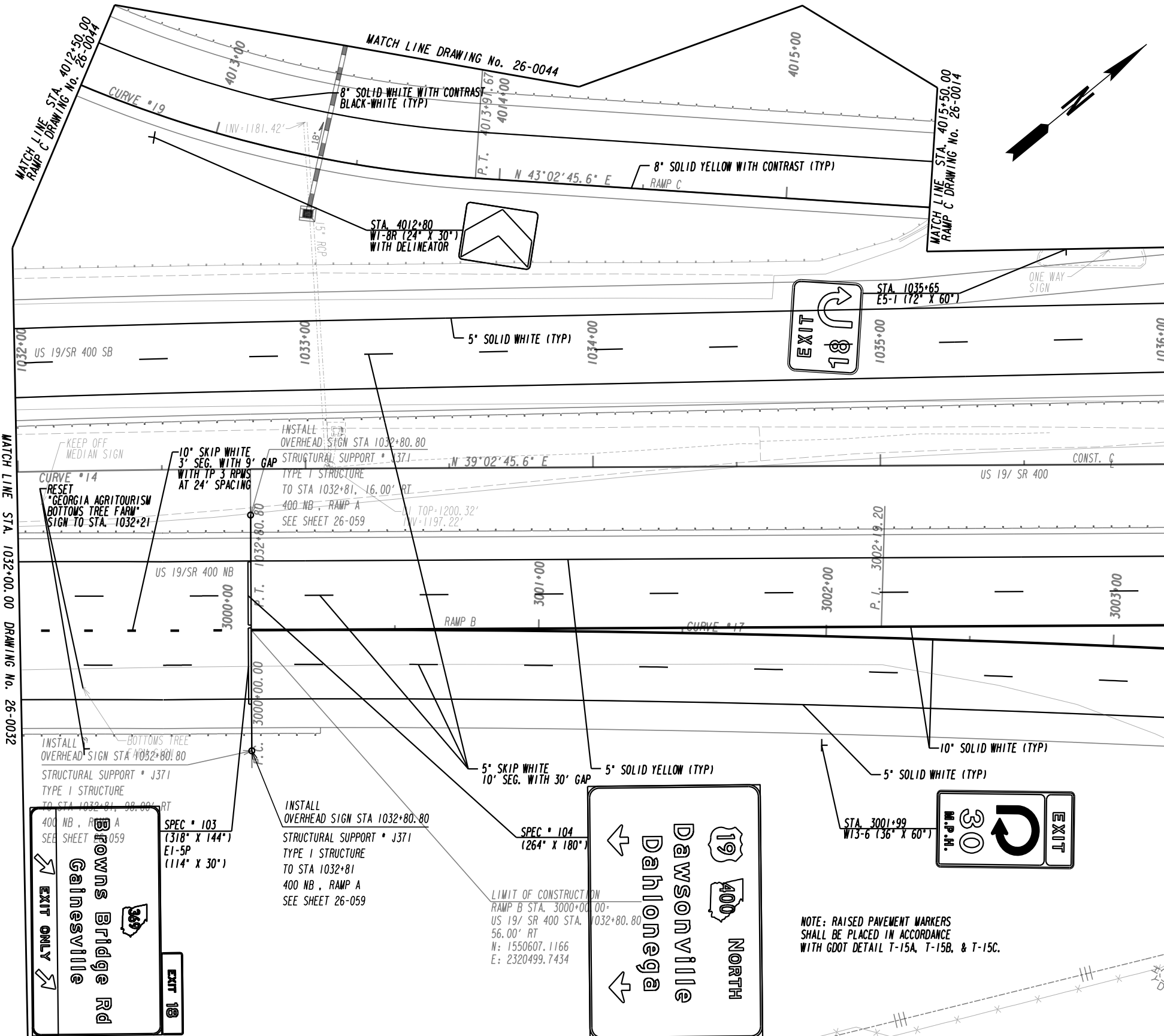

PROPERTY AND EXISTING R/W LINE
REQUIRED R/W LINE
CONSTRUCTION LIMITS
EASEMENT FOR CONSTR
& MAINTENANCE OF SLOPES
EASEMENT FOR CONSTR OF SLOPES
EASEMENT FOR CONSTR OF DRIVES
PAVEMENT/MEDIAN REMOVAL

BEGIN LIMIT OF ACCESS.....BLA
END LIMIT OF ACCESS.....ELA
LIMIT OF ACCESS
REQ'D R/W & LIMIT OF ACCESS
ORANGE BARRIER FENCE
ESA - ENV. SENSITIVE AREA
(SEE ERIT TABLE)

PLANS PREPARED AND SUBMITTED BY:

AEI
AMERICAN ENGINEERS, INC.
DESIGN CONSULTANT

PROFESSIONAL ENGINEERING

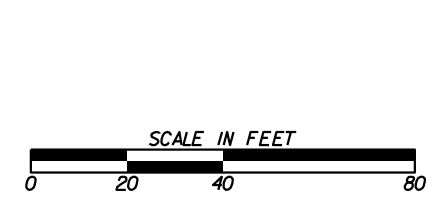

REVISION DATES

SIGNING AND MARKING PLANS

SR 400/US 19

CHECKED:		DATE:		DRAWING No.	
BACKCHECKED:		DATE:			
CORRECTED:		DATE:			
VERIFIED:		DATE:			

26-0033

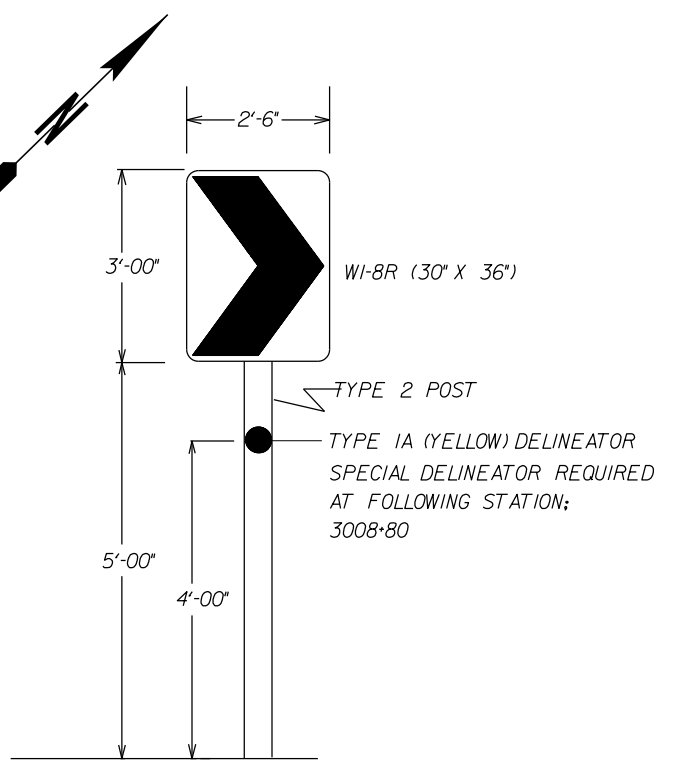
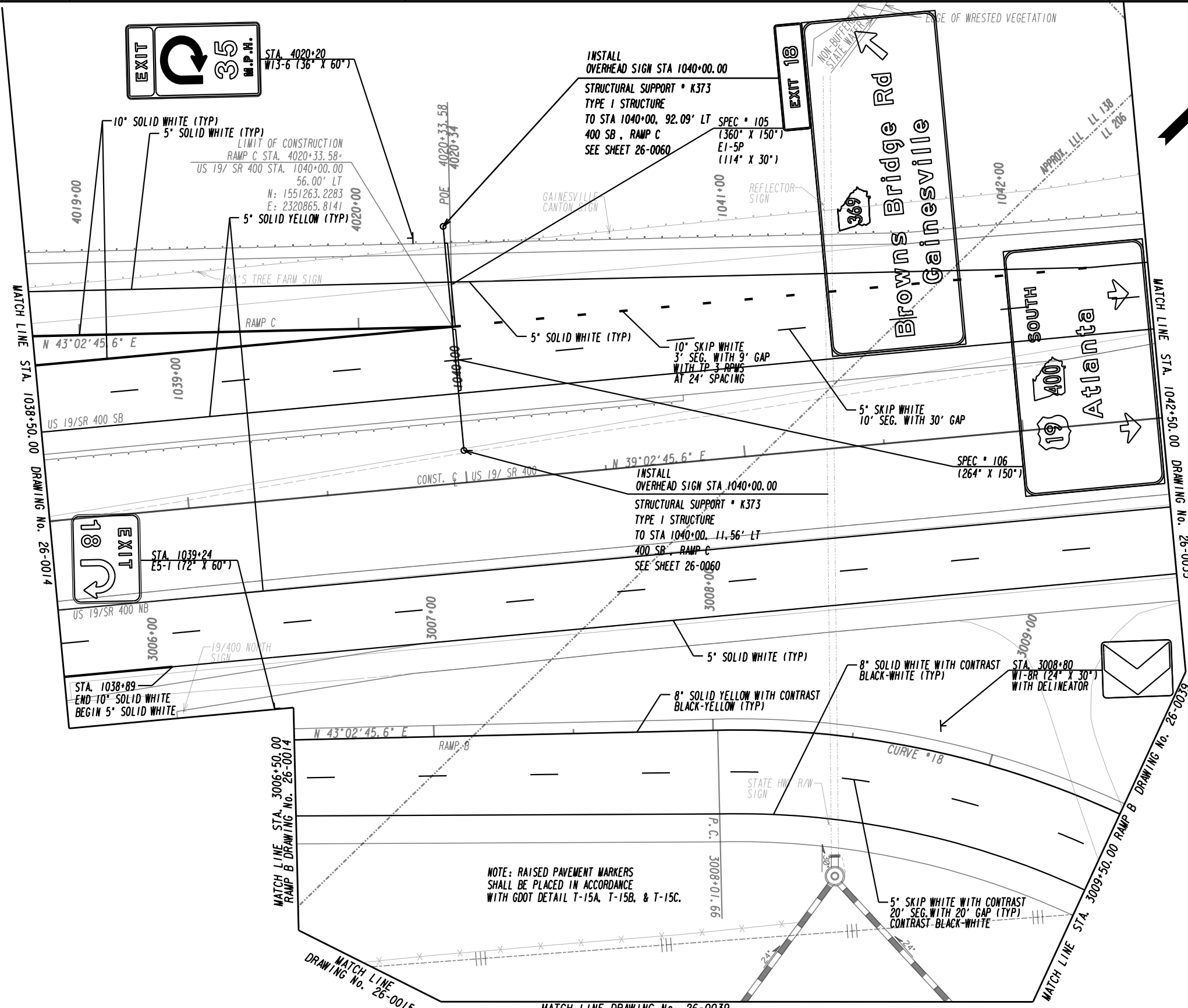

NOTE: RAISED PAVEMENT MARKERS SHALL BE PLACED IN ACCORDANCE WITH GOOT DETAIL T-15A, T-15B, & T-15C.

PROPERTY AND EXISTING R/W LINE	---
REQUIRED R/W LINE	---
CONSTRUCTION LIMITS	---
EASEMENT FOR CONSTR & MAINTENANCE OF SLOPES	---
EASEMENT FOR CONSTR OF SLOPES	---
EASEMENT FOR CONSTR OF DRIVES	---
PAVEMENT/MEDIAN REMOVAL	---

BEGIN LIMIT OF ACCESS.....BLA	---
END LIMIT OF ACCESS.....ELA	---
LIMIT OF ACCESS	---
REQ'D R/W & LIMIT OF ACCESS	---
ORANGE BARRIER FENCE	---
ESA - ENV. SENSITIVE AREA (SEE ERIT TABLE)	---

PLANS PREPARED AND SUBMITTED BY:

AEI
AMERICAN ENGINEERS, INC.
www.aei.cc

DESIGN CONSULTANT

PROFESSIONAL ENGINEERING

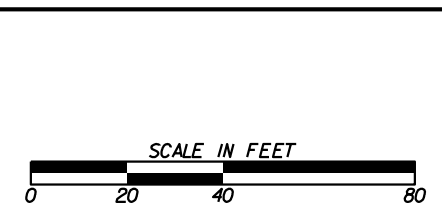

REVISION DATES	

SIGNING AND MARKING PLANS			
SR 400/US 19			
CHECKED:	DATE:	DRAWING No.	
BACKCHECKED:	DATE:	26-0034	
CORRECTED:	DATE:		
VERIFIED:	DATE:		

NOTE: RAISED PAVEMENT MARKERS
SHALL BE PLACED IN ACCORDANCE
WITH GDOT DETAIL T-15A, T-15B, & T-15C.

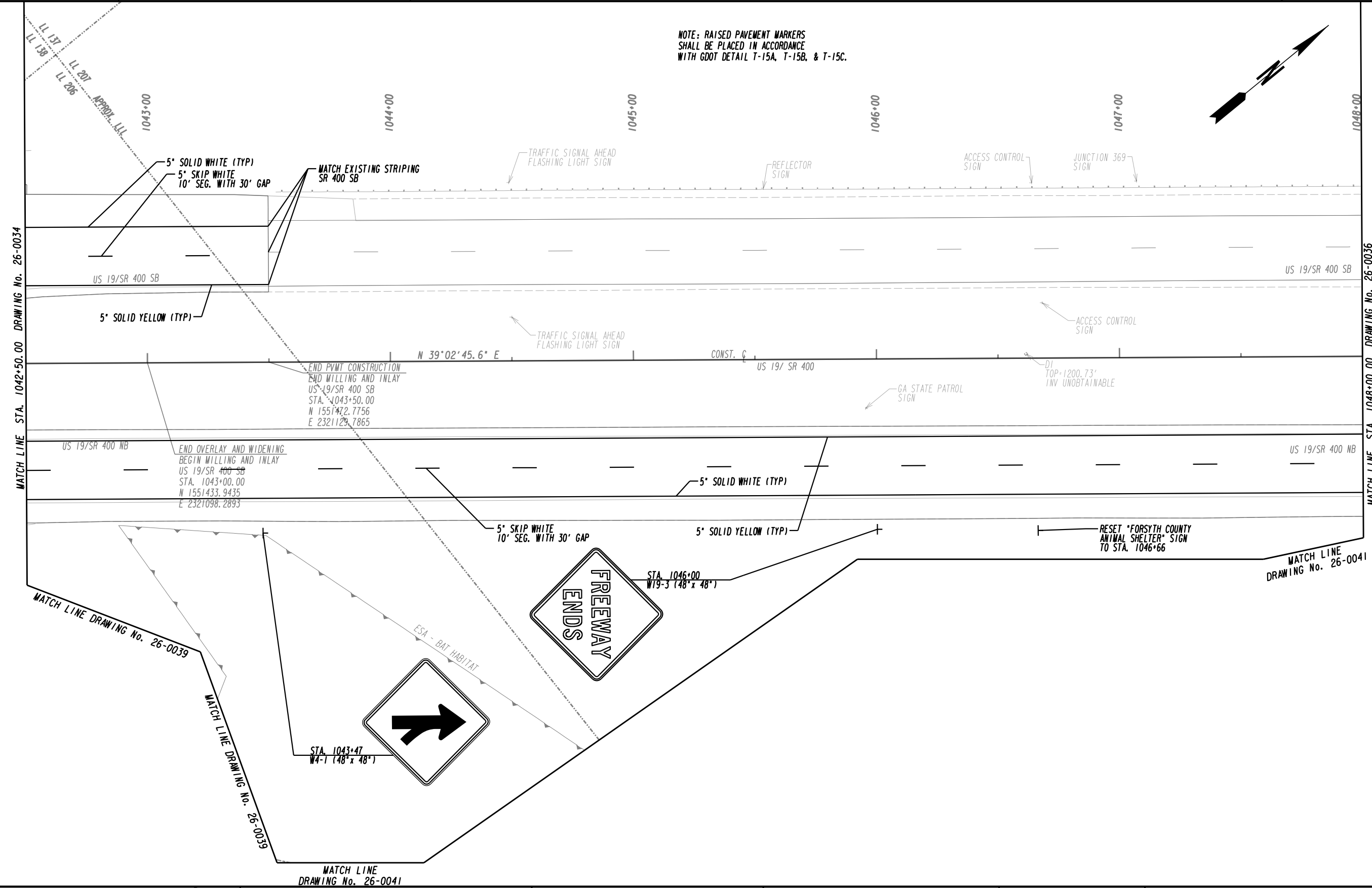
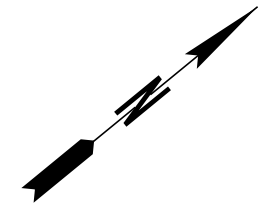

MATCH LINE STA. 1042+50.00 DRAWING No. 26-0034

MATCH LINE STA. 1048+00.00 DRAWING No. 26-0036

MATCH LINE DRAWING No. 26-0039

MATCH LINE DRAWING No. 26-0041

MATCH LINE DRAWING No. 26-0041

PROPERTY AND EXISTING R/W LINE	---
REQUIRED R/W LINE	---
CONSTRUCTION LIMITS	---
EASEMENT FOR CONSTR & MAINTENANCE OF SLOPES	▨
EASEMENT FOR CONSTR OF SLOPES	▩
EASEMENT FOR CONSTR OF DRIVES	▧
PAVEMENT/MEDIAN REMOVAL	▤

BEGIN LIMIT OF ACCESS.....BLA	---
END LIMIT OF ACCESS.....ELA	---
LIMIT OF ACCESS	---
REQ'D R/W & LIMIT OF ACCESS	---
ORANGE BARRIER FENCE	●
ESA - ENV. SENSITIVE AREA (SEE ERIT TABLE)	▼

PLANS PREPARED AND SUBMITTED BY:

AEI

AMERICAN ENGINEERS, INC.

DESIGN CONSULTANT

PROFESSIONAL ENGINEERING

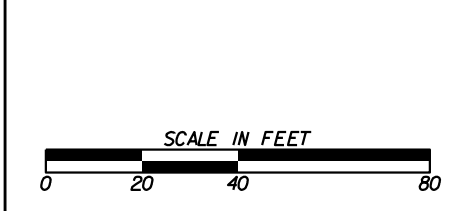

REVISION DATES	

SIGNING AND MARKING PLANS			
SR 400/US 19			
CHECKED:		DATE:	
BACKCHECKED:		DATE:	
CORRECTED:		DATE:	
VERIFIED:		DATE:	
DRAWING No.			26-0035

MATCH LINE STA. 1048+00.00 DRAWING No. 26-0035

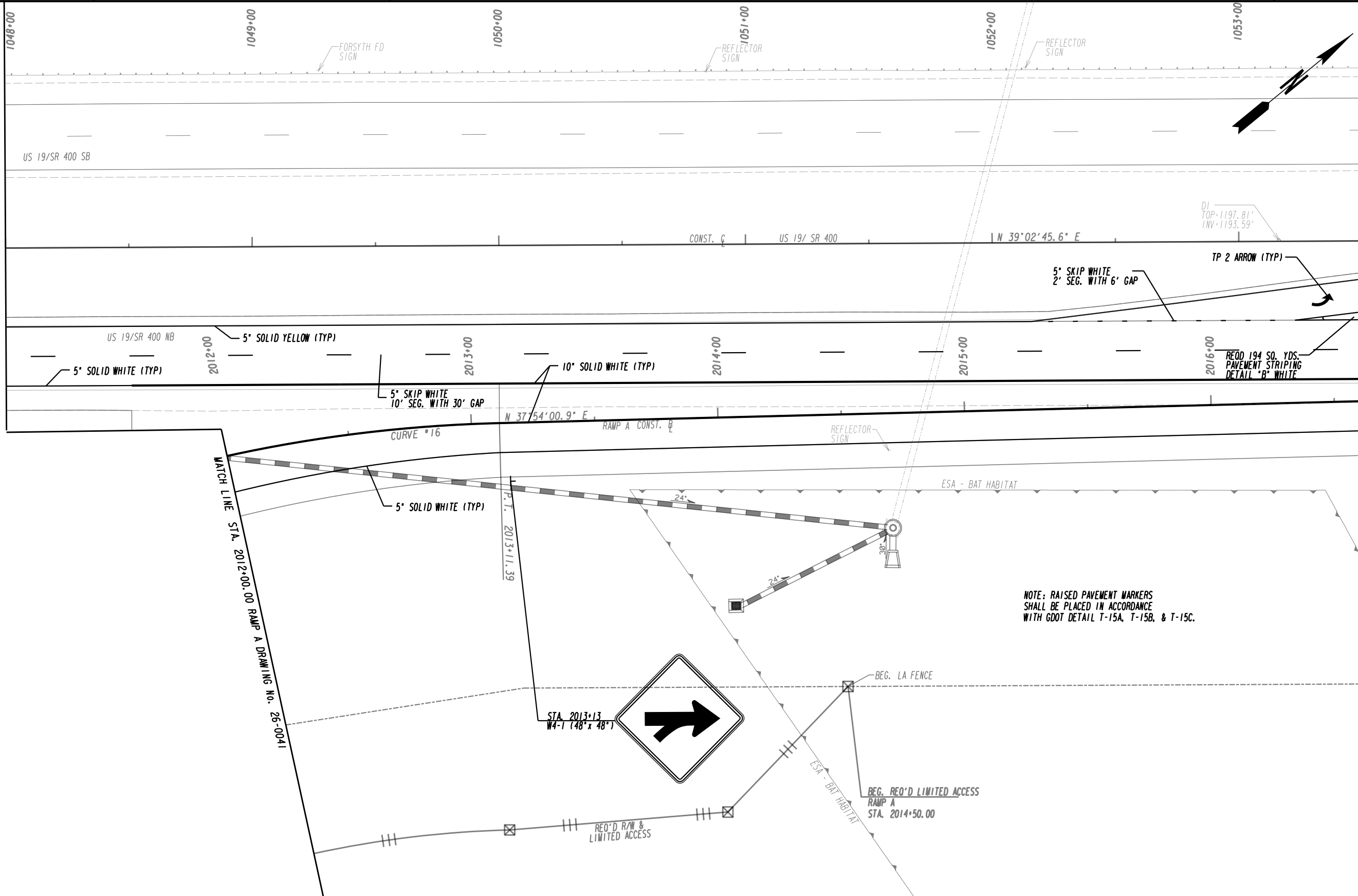

MATCH LINE STA. 1053+50.00 DRAWING No. 26-0037

NOTE: RAISED PAVEMENT MARKERS SHALL BE PLACED IN ACCORDANCE WITH GDOT DETAIL T-15A, T-15B, & T-15C.

PROPERTY AND EXISTING R/W LINE	---
REQUIRED R/W LINE	---
CONSTRUCTION LIMITS	---
EASEMENT FOR CONSTR & MAINTENANCE OF SLOPES	▨
EASEMENT FOR CONSTR OF SLOPES	▩
EASEMENT FOR CONSTR OF DRIVES	▧
PAVEMENT/MEDIAN REMOVAL	▤

BEGIN LIMIT OF ACCESS.....BLA	---
END LIMIT OF ACCESS.....ELA	---
LIMIT OF ACCESS	---
REQ'D R/W & LIMIT OF ACCESS	---
ORANGE BARRIER FENCE	---
ESA - ENV. SENSITIVE AREA (SEE ERIT TABLE)	---

PLANS PREPARED AND SUBMITTED BY:

AEI
AMERICAN ENGINEERS, INC.
www.aei.cc

DESIGN CONSULTANT

PROFESSIONAL ENGINEERING

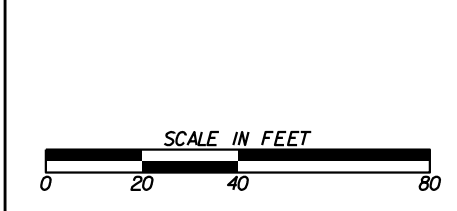

REVISION DATES	

SIGNING AND MARKING PLANS			
SR 400/US 19			
CHECKED:		DATE:	
BACKCHECKED:		DATE:	
CORRECTED:		DATE:	
VERIFIED:		DATE:	
DRAWING No.			26-0036

MATCH LINE STA. 1053+50.00 DRAWING No. 26-0036

MATCH LINE STA. 1059+00.00 DRAWING No. 26-0038

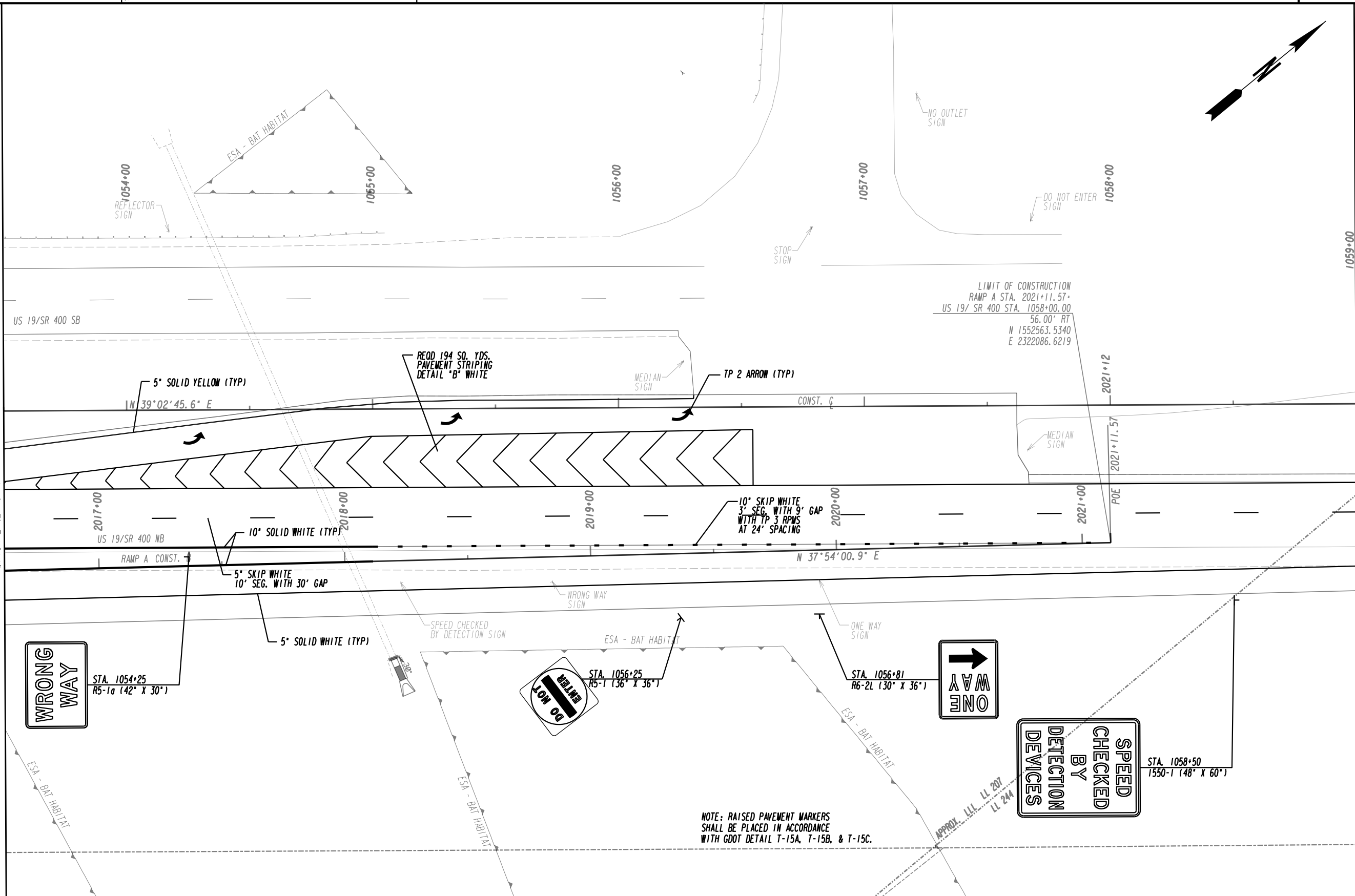

LIMIT OF CONSTRUCTION
 RAMP A STA. 2021+11.57+
 US 19/ SR 400 STA. 1058+00.00
 56.00' RT
 N 1552563.5340
 E 2322086.6219

NOTE: RAISED PAVEMENT MARKERS
 SHALL BE PLACED IN ACCORDANCE
 WITH GDOT DETAIL T-15A, T-15B, & T-15C.

PROPERTY AND EXISTING R/W LINE	---
REQUIRED R/W LINE	---
CONSTRUCTION LIMITS	---
EASEMENT FOR CONSTR	---
& MAINTENANCE OF SLOPES	---
EASEMENT FOR CONSTR OF SLOPES	---
EASEMENT FOR CONSTR OF DRIVES	---
PAVEMENT/MEDIAN REMOVAL	---

BEGIN LIMIT OF ACCESS.....BLA	---
END LIMIT OF ACCESS.....ELA	---
LIMIT OF ACCESS	---
REQ'D R/W & LIMIT OF ACCESS	---
ORANGE BARRIER FENCE	---
ESA - ENV. SENSITIVE AREA	---
(SEE ERIT TABLE)	---

PLANS PREPARED AND SUBMITTED BY:

AEI
 AMERICAN ENGINEERS, INC.
 DESIGN CONSULTANT

PROFESSIONAL ENGINEERING

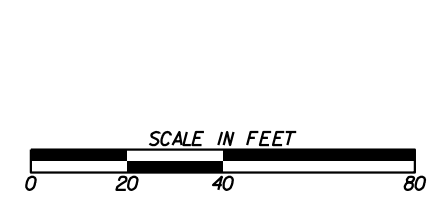

REVISION DATES	

SIGNING AND MARKING PLANS			
SR 400/US 19			
CHECKED:		DATE:	
BACKCHECKED:		DATE:	
CORRECTED:		DATE:	
VERIFIED:		DATE:	
DRAWING No.			26-0037

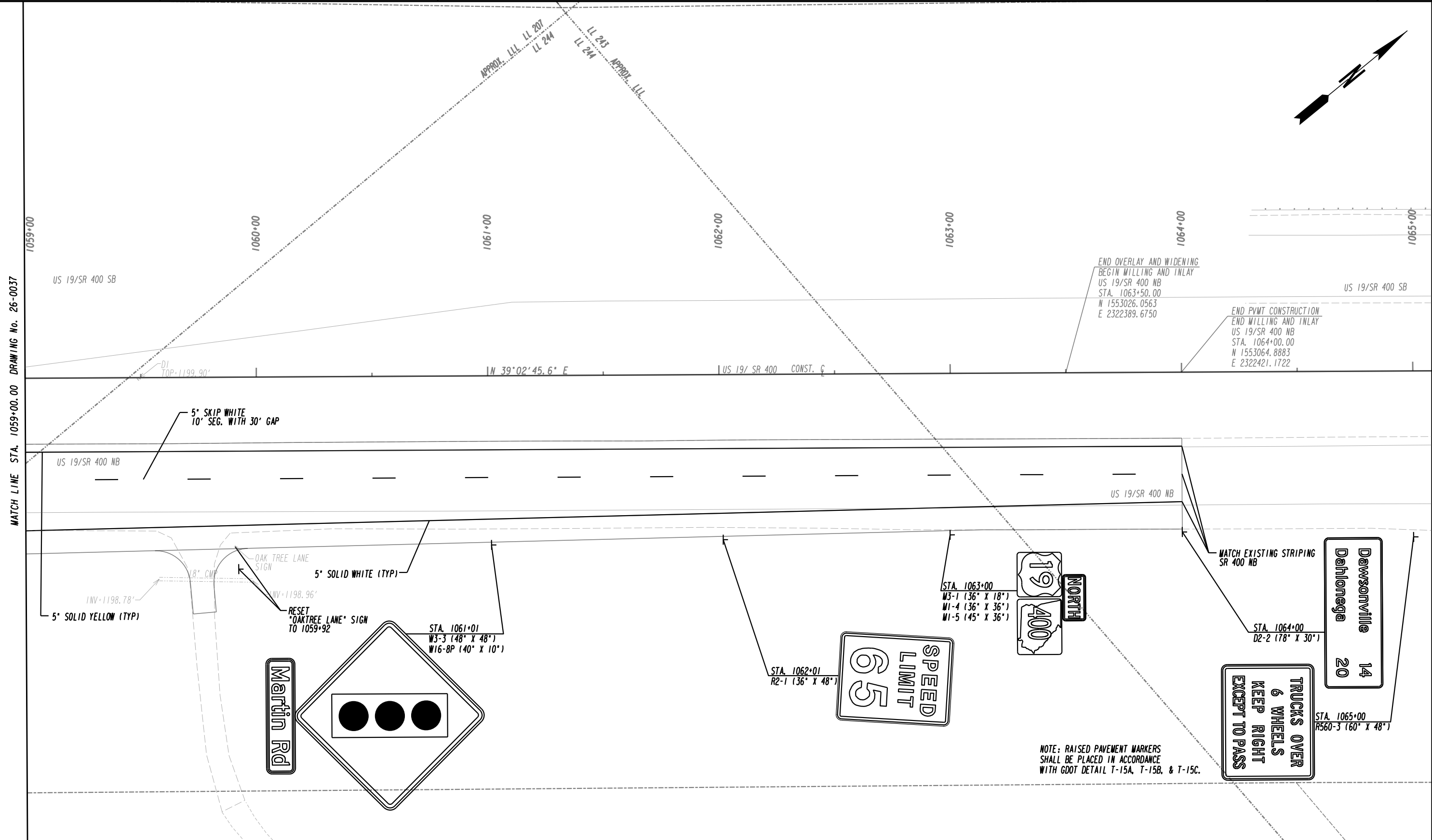
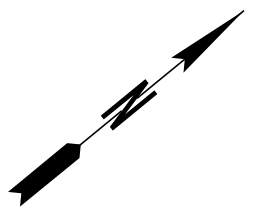

PROPERTY AND EXISTING R/W LINE
REQUIRED R/W LINE
CONSTRUCTION LIMITS
EASEMENT FOR CONSTR
& MAINTENANCE OF SLOPES
EASEMENT FOR CONSTR OF SLOPES
EASEMENT FOR CONSTR OF DRIVES
PAVEMENT/MEDIAN REMOVAL

---	---
---	---
---	---
---	---
---	---
---	---
---	---
---	---

BEGIN LIMIT OF ACCESS.....BLA
END LIMIT OF ACCESS.....ELA
LIMIT OF ACCESS
REQ'D R/W & LIMIT OF ACCESS
ORANGE BARRIER FENCE
ESA - ENV. SENSITIVE AREA
(SEE ERIT TABLE)

---	---
---	---
---	---
---	---
---	---
---	---

PLANS PREPARED AND SUBMITTED BY:

AEI
AMERICAN ENGINEERS, INC.
DESIGN CONSULTANT

PROFESSIONAL ENGINEERING

Branch Office:
 65 Aberdeen Drive
 Glasgow, KY 40304
 (270) 651-7220
 1634 White Circle, Suite 101
 Marietta, GA 30066
 (770) 421-8422
 2500 Nelson Miller Parkway
 Louisville, KY 40223
 (502) 245-3813

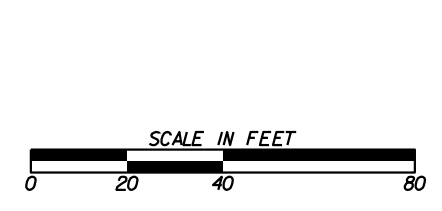

REVISION DATES

SIGNING AND MARKING PLANS

SR 400/US 19

CHECKED:	DATE:	DRAWING No.
BACKCHECKED:	DATE:	26-0038
CORRECTED:	DATE:	
VERIFIED:	DATE:	

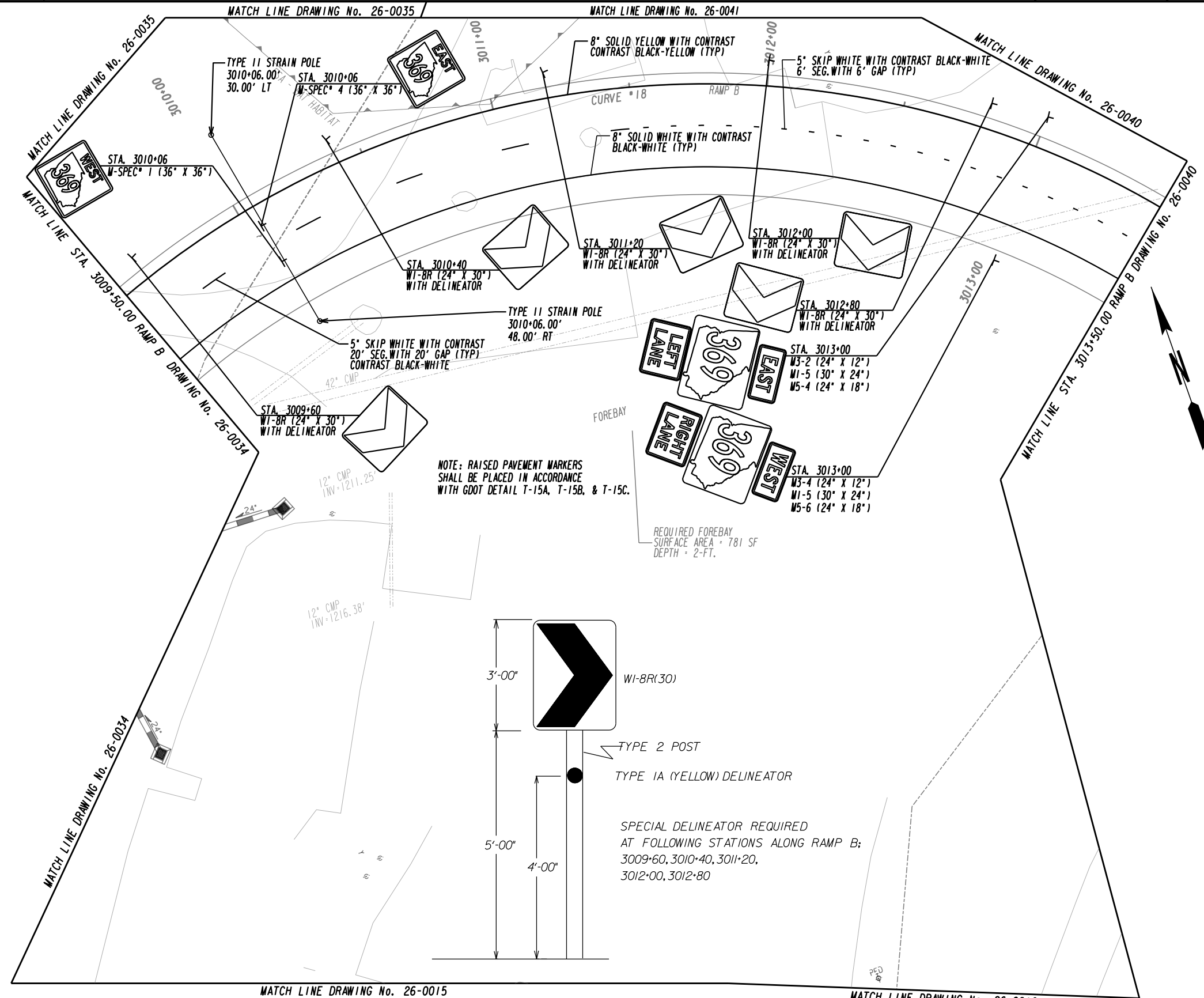

NOTE: RAISED PAVEMENT MARKERS SHALL BE PLACED IN ACCORDANCE WITH GDOT DETAIL T-15A, T-15B, & T-15C.

REQUIRED FOREBAY SURFACE AREA = 781 SF DEPTH = 2'-FT.

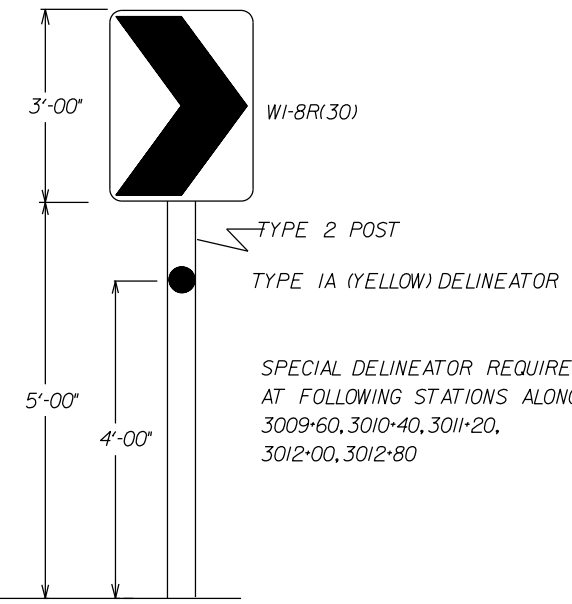

SPECIAL DELINEATOR REQUIRED AT FOLLOWING STATIONS ALONG RAMP B:
3009+60, 3010+40, 3011+20, 3012+00, 3012+80

PROPERTY AND EXISTING R/W LINE	---
REQUIRED R/W LINE	---
CONSTRUCTION LIMITS	---
EASEMENT FOR CONSTR & MAINTENANCE OF SLOPES	---
EASEMENT FOR CONSTR OF SLOPES	---
EASEMENT FOR CONSTR OF DRIVES	---
PAVEMENT/MEDIAN REMOVAL	---

BEGIN LIMIT OF ACCESS.....BLA	---
END LIMIT OF ACCESS.....ELA	---
LIMIT OF ACCESS	---
REQ'D R/W & LIMIT OF ACCESS	---
ORANGE BARRIER FENCE	---
ESA - ENV. SENSITIVE AREA (SEE ERIT TABLE)	---

PLANS PREPARED AND SUBMITTED BY:

AEI
AMERICAN ENGINEERS, INC.
DESIGN CONSULTANT

PROFESSIONAL ENGINEERING

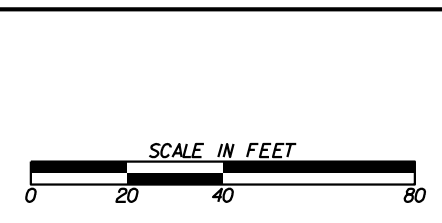

REVISION DATES	

SIGNING AND MARKING PLANS

RAMP A
RAMP B

CHECKED:	DATE:	DRAWING No.
BACKCHECKED:	DATE:	26-0039
CORRECTED:	DATE:	
VERIFIED:	DATE:	

MATCH LINE DRAWING No. 26-0039

MATCH LINE STA. 3013+50.00 RAMP B DRAWING No. 26-0039

MATCH LINE DRAWING No. 26-0039

MATCH LINE STA. 2007+00 RAMP A DRAWING No. 26-0041

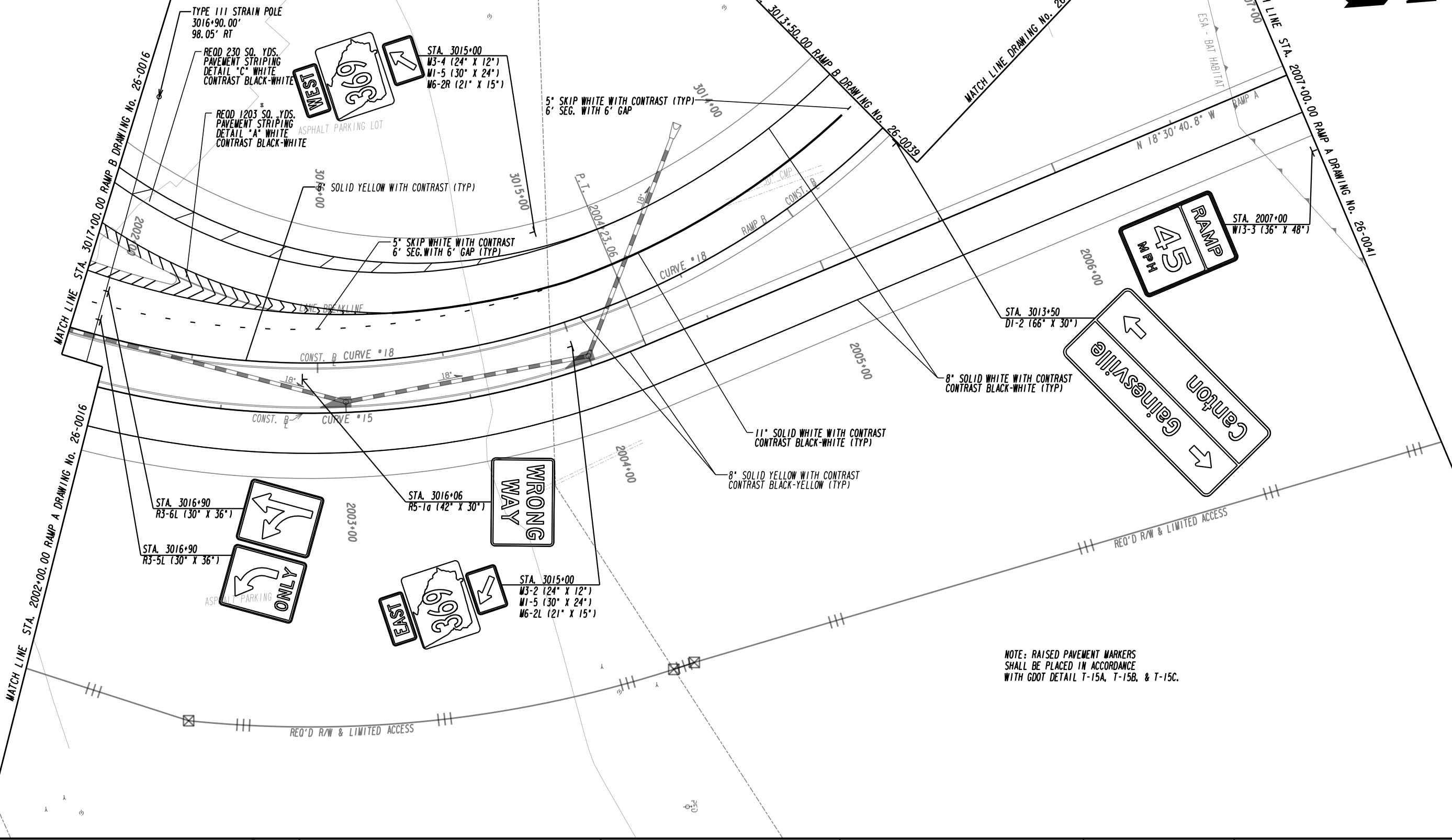

NOTE: RAISED PAVEMENT MARKERS SHALL BE PLACED IN ACCORDANCE WITH GDOT DETAIL T-15A, T-15B, & T-15C.

PROPERTY AND EXISTING R/W LINE
REQUIRED R/W LINE
CONSTRUCTION LIMITS
EASEMENT FOR CONSTR
& MAINTENANCE OF SLOPES
EASEMENT FOR CONSTR OF SLOPES
EASEMENT FOR CONSTR OF DRIVES
PAVEMENT/MEDIAN REMOVAL

---	---
---	---
---	---
---	---
---	---
---	---
---	---
---	---

BEGIN LIMIT OF ACCESS.....BLA
END LIMIT OF ACCESS.....ELA
LIMIT OF ACCESS
REQ'D R/W & LIMIT OF ACCESS
ORANGE BARRIER FENCE
ESA - ENV. SENSITIVE AREA
(SEE ERIT TABLE)

---	---
---	---
---	---
---	---
---	---
---	---

PLANS PREPARED AND SUBMITTED BY:

AEI
AMERICAN ENGINEERS, INC.
DESIGN CONSULTANT

PROFESSIONAL ENGINEERING

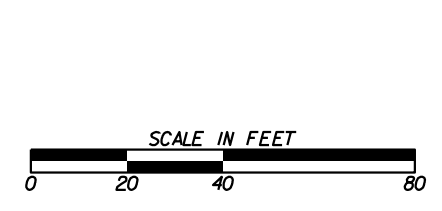

REVISION DATES

SIGNING AND MARKING PLANS

RAMP A
RAMP B

CHECKED:		DATE:		DRAWING No.
BACKCHECKED:		DATE:		26-0040
CORRECTED:		DATE:		
VERIFIED:		DATE:		

MATCH LINE DRAWING No. 26-0035



MATCH LINE DRAWING No. 26-0039

ESA - BAT HABITAT

2008+00

2009+00

2010+00

MATCH LINE DRAWING No. 26-0035

2011+00

MATCH LINE DRAWING No. 26-0035

2012+00

MATCH LINE STA. 2012+00.00 RAMP A DRAWING No. 26-0036

2007+00

MATCH LINE STA. 2007+00.00 RAMP A DRAWING No. 26-0040

N 18° 30' 40.18" W

P.C. 2007+33.45

8" SOLID YELLOW WITH CONTRAST (TYP)

8" SOLID WHITE WITH CONTRAST (TYP)

CURVE °16

RAMP A

CONST. @

END CONCRETE PVMT CONSTRUCTION
BEGIN ASPHALT PVMT CONSTRUCTION
RAMP A
STA. 2011+61.39
N 1551003.3419
E 2321518.9794

STA. 2011+61
END CONTRAST STRIPING
BEGIN THERMOPLASTIC
10" SOLID WHITE (TYP)
5" SOLID WHITE (TYP)

NOTE: RAISED PAVEMENT MARKERS
SHALL BE PLACED IN ACCORDANCE
WITH GDOT DETAIL T-15A, T-15B, & T-15C.

ESA - BAT HABITAT

ESA - BAT HABITAT

APPROX. LL 206
LL 207

REQ'D R/W & LIMITED ACCESS

PROPERTY AND EXISTING R/W LINE
REQUIRED R/W LINE
CONSTRUCTION LIMITS
EASEMENT FOR CONSTR
& MAINTENANCE OF SLOPES
EASEMENT FOR CONSTR OF SLOPES
EASEMENT FOR CONSTR OF DRIVES
PAVEMENT/MEDIAN REMOVAL

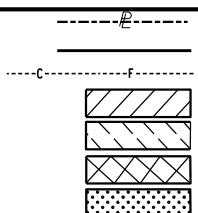

BEGIN LIMIT OF ACCESS.....BLA
END LIMIT OF ACCESS.....ELA
LIMIT OF ACCESS
REQ'D R/W & LIMIT OF ACCESS
ORANGE BARRIER FENCE
ESA - ENV. SENSITIVE AREA
(SEE ERIT TABLE)

PLANS PREPARED AND SUBMITTED BY:
Branch Office
O 65 Aberdeen Drive
Cincinnati, KY 45241
(270) 651-7220
O 2500 Nelson Miller Parkway
Louisville, KY 40223
(502) 245-3813
www.aei.cc
DESIGN CONSULTANT
1634 White Circle, Suite 101
Marietta, GA 30066
(770) 421-8422
PROFESSIONAL ENGINEERING

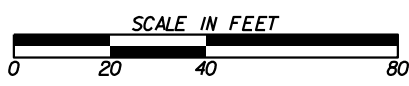

REVISION DATES table with columns for date and description.

SIGNING AND MARKING PLANS table with columns for RAMP A, RAMP B, CHECKED, DATE, CORRECTED, DATE, VERIFIED, DATE, and DRAWING No. 26-0041.

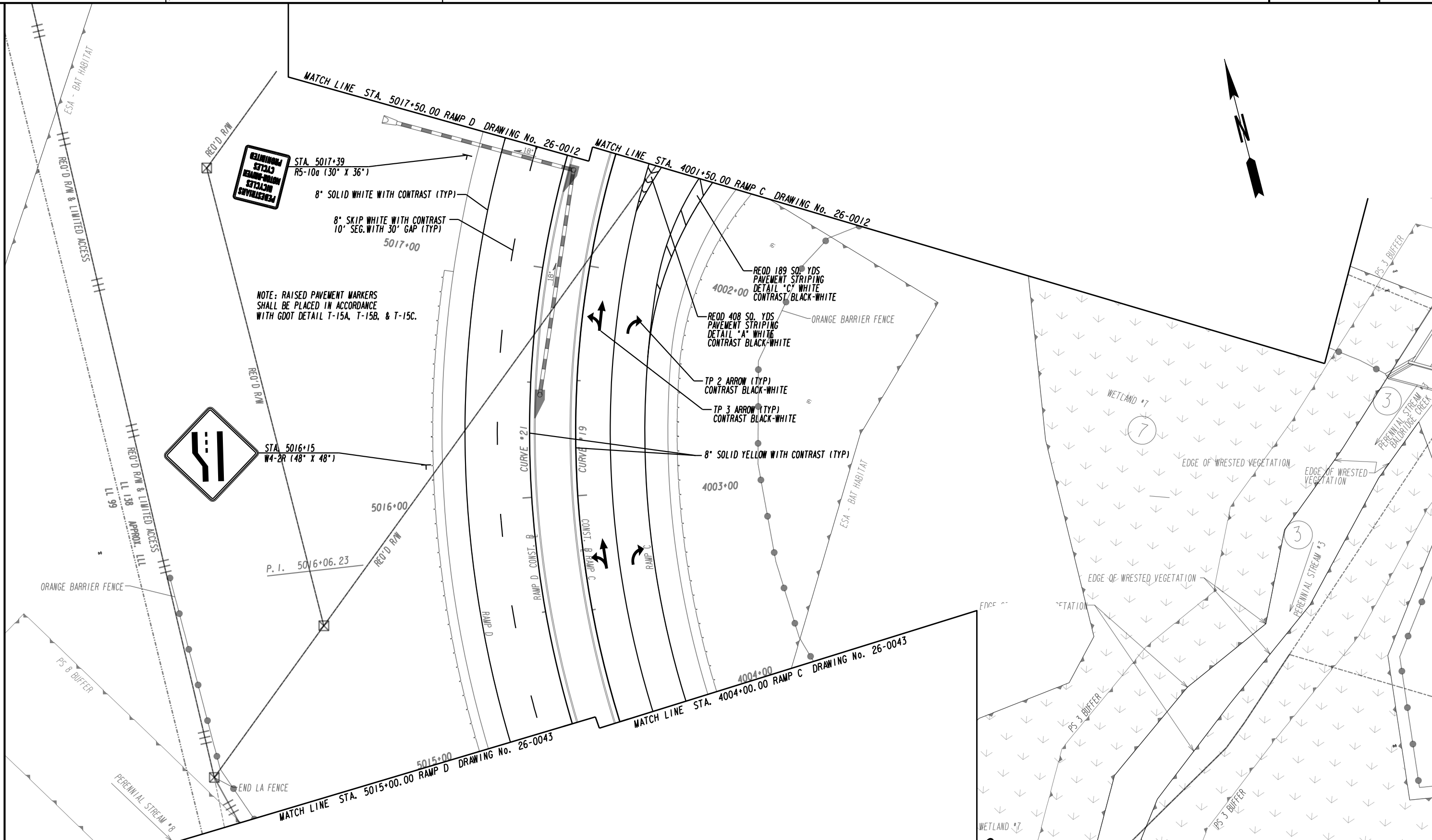

PROHIBITED
CYCLES
REARVIEW
MIRRORS
CYCLES
REARVIEW
MIRRORS

NOTE: RAISED PAVEMENT MARKERS
SHALL BE PLACED IN ACCORDANCE
WITH GDOT DETAIL T-15A, T-15B, & T-15C.



PROPERTY AND EXISTING R/W LINE	---
REQUIRED R/W LINE	---
CONSTRUCTION LIMITS	---
EASEMENT FOR CONSTR	---
& MAINTENANCE OF SLOPES	---
EASEMENT FOR CONSTR OF SLOPES	---
EASEMENT FOR CONSTR OF DRIVES	---
PAVEMENT/MEDIAN REMOVAL	---

BEGIN LIMIT OF ACCESS.....BLA	---
END LIMIT OF ACCESS.....ELA	---
LIMIT OF ACCESS	---
REQ'D R/W & LIMIT OF ACCESS	---
ORANGE BARRIER FENCE	---
ESA - ENV. SENSITIVE AREA	---
(SEE ERIT TABLE)	---

PLANS PREPARED AND SUBMITTED BY:
AEI
 AMERICAN ENGINEERS, INC.
 DESIGN CONSULTANT
 PROFESSIONAL ENGINEERING

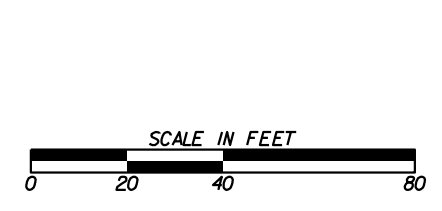

REVISION	DATE

SIGNING AND MARKING PLANS		
RAMP C RAMP D		
CHECKED:	DATE:	DRAWING No.
BACKCHECKED:	DATE:	26-0042
CORRECTED:	DATE:	
VERIFIED:	DATE:	

MATCH LINE STA. 5015+00.00 RAMP D DRAWING No. 26-0042

MATCH LINE STA. 4004+00.00 RAMP C DRAWING No. 26-0042

NOTE: RAISED PAVEMENT MARKERS SHALL BE PLACED IN ACCORDANCE WITH GDOT DETAIL T-15A, T-15B, & T-15C.

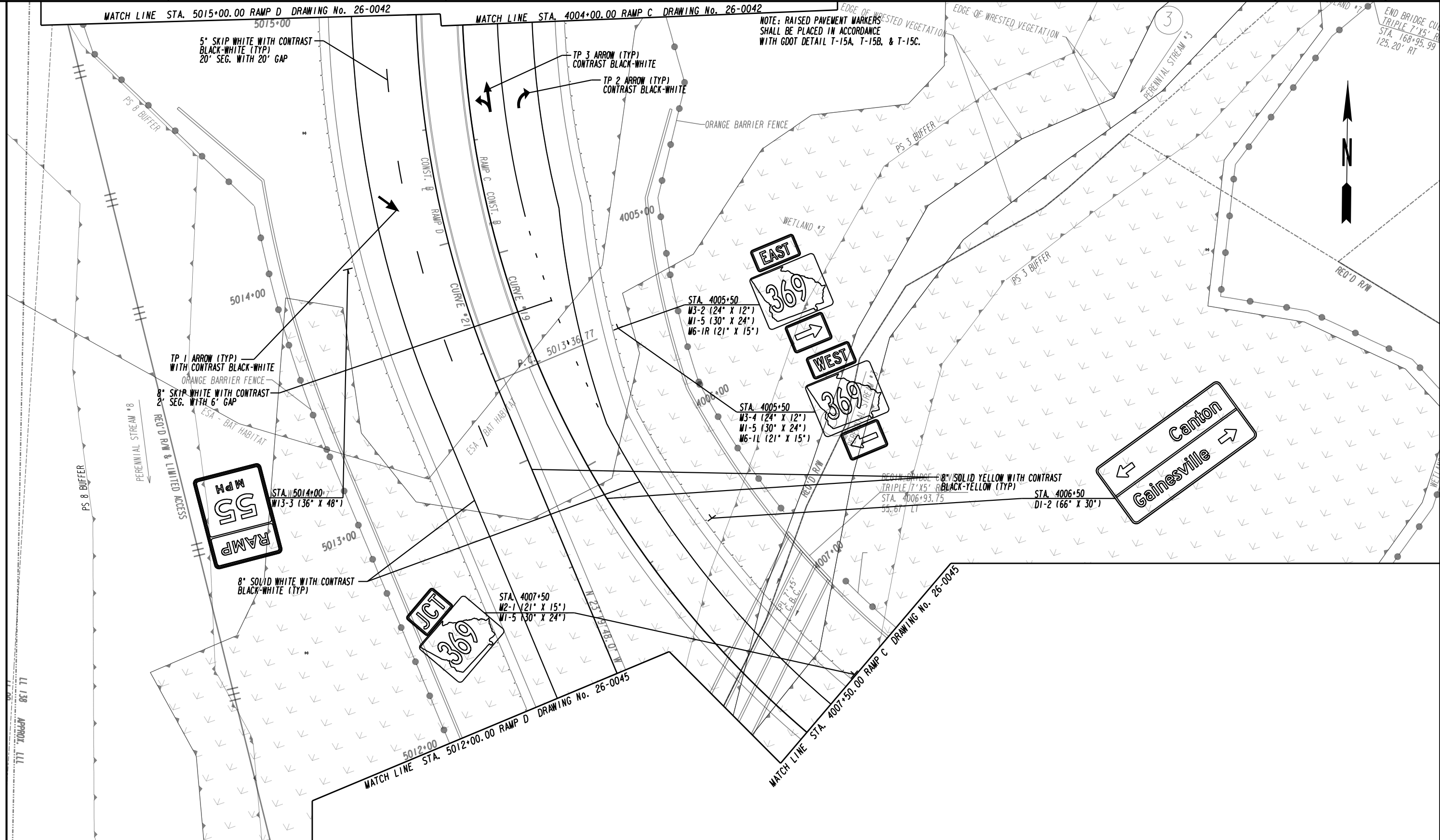

PROPERTY AND EXISTING R/W LINE	---
REQUIRED R/W LINE	---
CONSTRUCTION LIMITS	---
EASEMENT FOR CONSTR & MAINTENANCE OF SLOPES	---
EASEMENT FOR CONSTR OF SLOPES	---
EASEMENT FOR CONSTR OF DRIVES	---
PAVEMENT/MEDIAN REMOVAL	---

BEGIN LIMIT OF ACCESS.....BLA	---
END LIMIT OF ACCESS.....ELA	---
LIMIT OF ACCESS	---
REQ'D R/W & LIMIT OF ACCESS	---
ORANGE BARRIER FENCE	---
ESA - ENV. SENSITIVE AREA (SEE ERIT TABLE)	---

PLANS PREPARED AND SUBMITTED BY:

AEI
AMERICAN ENGINEERS, INC.
DESIGN CONSULTANT

PROFESSIONAL ENGINEERING

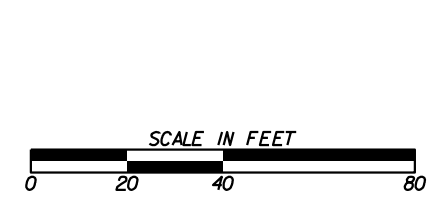

REVISION DATES	

SIGNING AND MARKING PLANS			
RAMP C		RAMP D	
CHECKED:	DATE:	CHECKED:	DATE:
BACKCHECKED:	DATE:	BACKCHECKED:	DATE:
CORRECTED:	DATE:	CORRECTED:	DATE:
VERIFIED:	DATE:	VERIFIED:	DATE:
DRAWING No.			26-0043

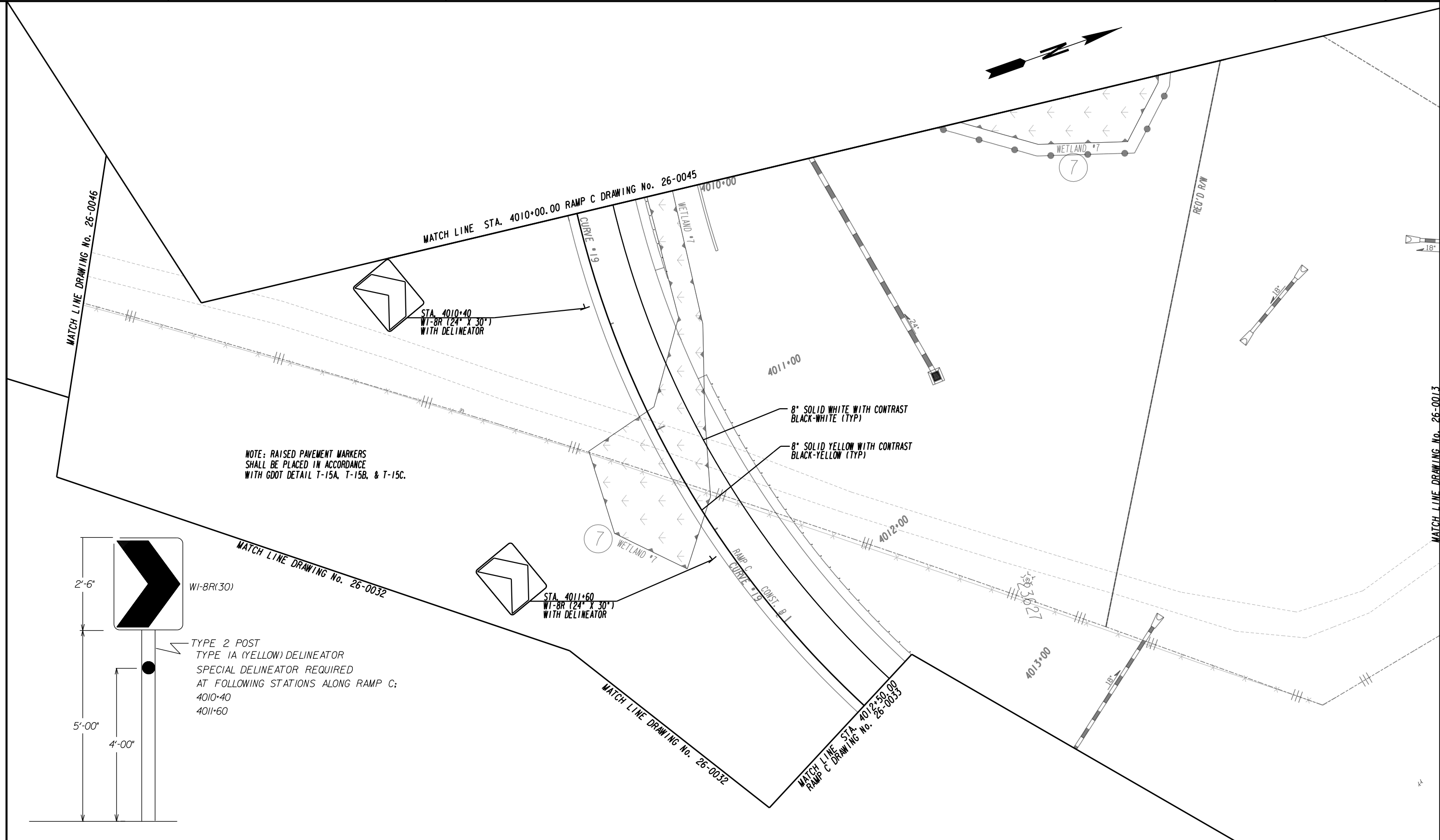

NOTE: RAISED PAVEMENT MARKERS SHALL BE PLACED IN ACCORDANCE WITH GDOT DETAIL T-15A, T-15B, & T-15C.

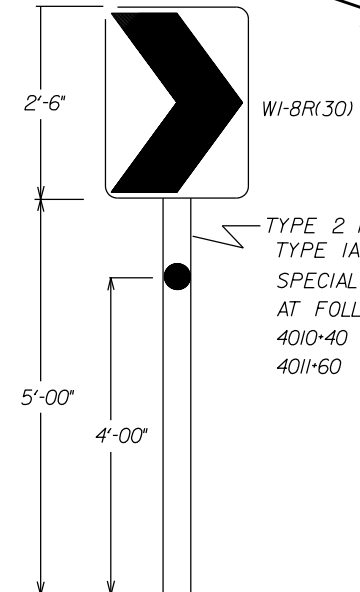

TYPE 2 POST
TYPE 1A (YELLOW) DELINEATOR
SPECIAL DELINEATOR REQUIRED AT FOLLOWING STATIONS ALONG RAMP C:
4010+40
4011+60

PROPERTY AND EXISTING R/W LINE	---
REQUIRED R/W LINE	---
CONSTRUCTION LIMITS	---
EASEMENT FOR CONSTR & MAINTENANCE OF SLOPES	---
EASEMENT FOR CONSTR OF SLOPES	---
EASEMENT FOR CONSTR OF DRIVES	---
PAVEMENT/MEDIAN REMOVAL	---

BEGIN LIMIT OF ACCESS.....BLA	---
END LIMIT OF ACCESS.....ELA	---
LIMIT OF ACCESS	---
REQ'D R/W & LIMIT OF ACCESS	---
ORANGE BARRIER FENCE	---
ESA - ENV. SENSITIVE AREA (SEE ERIT TABLE)	---

PLANS PREPARED AND SUBMITTED BY:

AEI
AMERICAN ENGINEERS, INC.
DESIGN CONSULTANT

PROFESSIONAL ENGINEERING

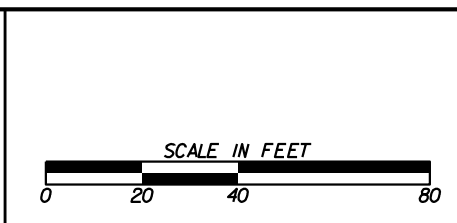

REVISION DATES	

SIGNING AND MARKING PLANS			
RAMP C			
CHECKED:		DATE:	
BACKCHECKED:		DATE:	
CORRECTED:		DATE:	
VERIFIED:		DATE:	
DRAWING No.			26-0044

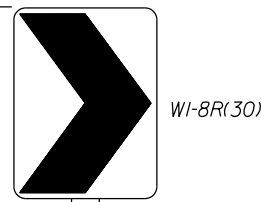
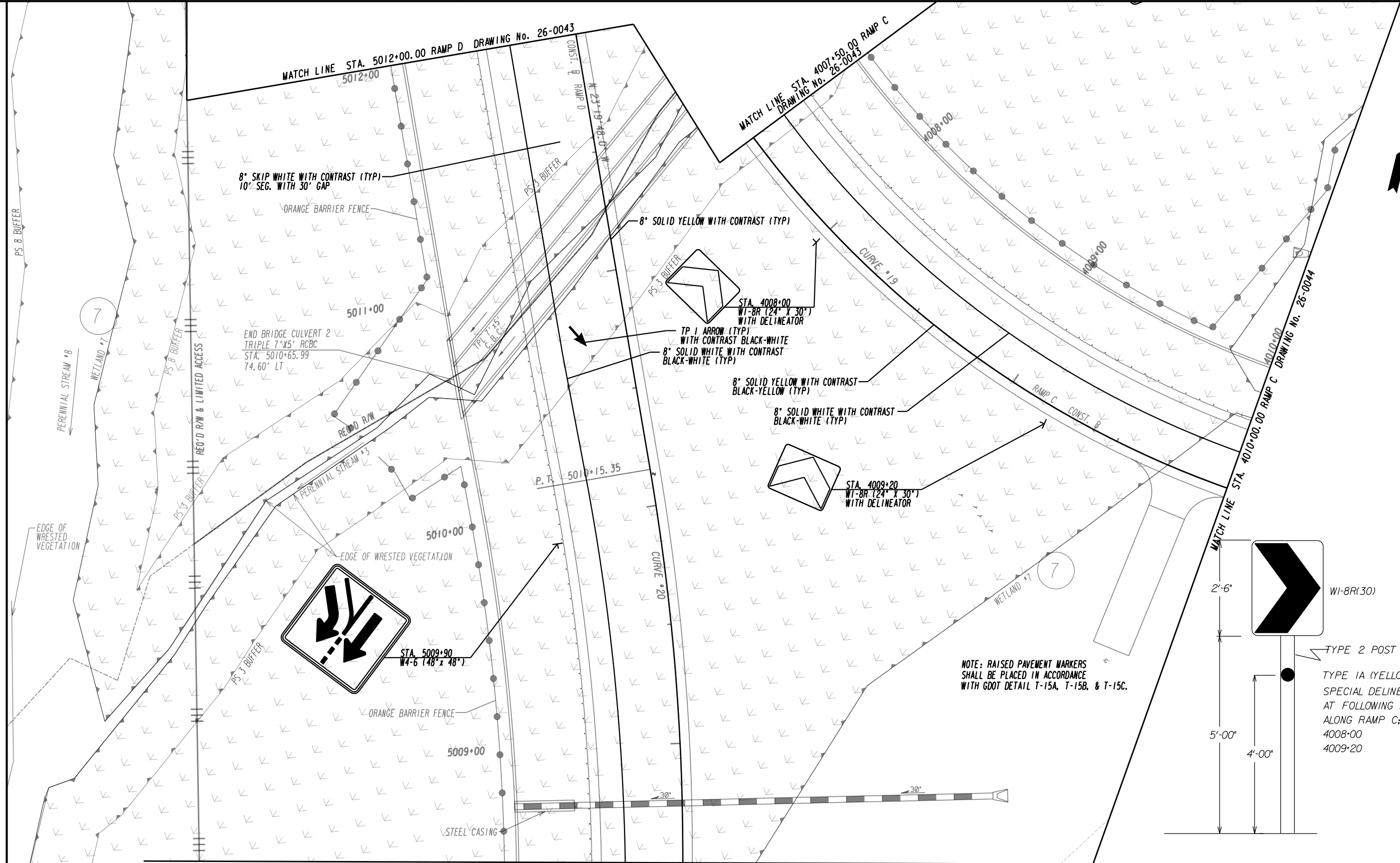

TYPE 2 POST
TYPE 1A (YELLOW) DELINEATOR
SPECIAL DELINEATOR REQUIRED
AT FOLLOWING STATIONS
ALONG RAMP C:
4008+00
4009+20

NOTE: RAISED PAVEMENT MARKERS
SHALL BE PLACED IN ACCORDANCE
WITH GDOT DETAIL T-15A, T-15B, & T-15C.

PROPERTY AND EXISTING R/W LINE	---
REQUIRED R/W LINE	---
CONSTRUCTION LIMITS	---
EASEMENT FOR CONSTR	---
& MAINTENANCE OF SLOPES	---
EASEMENT FOR CONSTR OF SLOPES	---
EASEMENT FOR CONSTR OF DRIVES	---
PAVEMENT/MEDIAN REMOVAL	---

BEGIN LIMIT OF ACCESS.....BLA	---
END LIMIT OF ACCESS.....ELA	---
LIMIT OF ACCESS	---
REQ'D R/W & LIMIT OF ACCESS	---
ORANGE BARRIER FENCE	---
ESA - ENV. SENSITIVE AREA	---
(SEE ERIT TABLE)	---

PLANS PREPARED AND SUBMITTED BY:

AEI
AMERICAN ENGINEERS, INC.
DESIGN CONSULTANT

PROFESSIONAL ENGINEERING

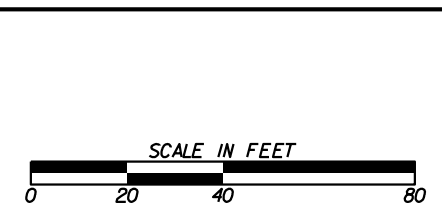

REVISION DATES	

SIGNING AND MARKING PLANS			
RAMP C		DRAWING No.	
RAMP D		26-0045	
CHECKED:	DATE:	CHECKED:	DATE:
BACKCHECKED:	DATE:	CORRECTED:	DATE:
VERIFIED:	DATE:	VERIFIED:	DATE:

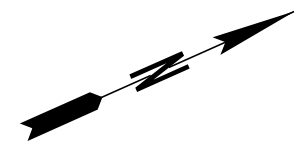
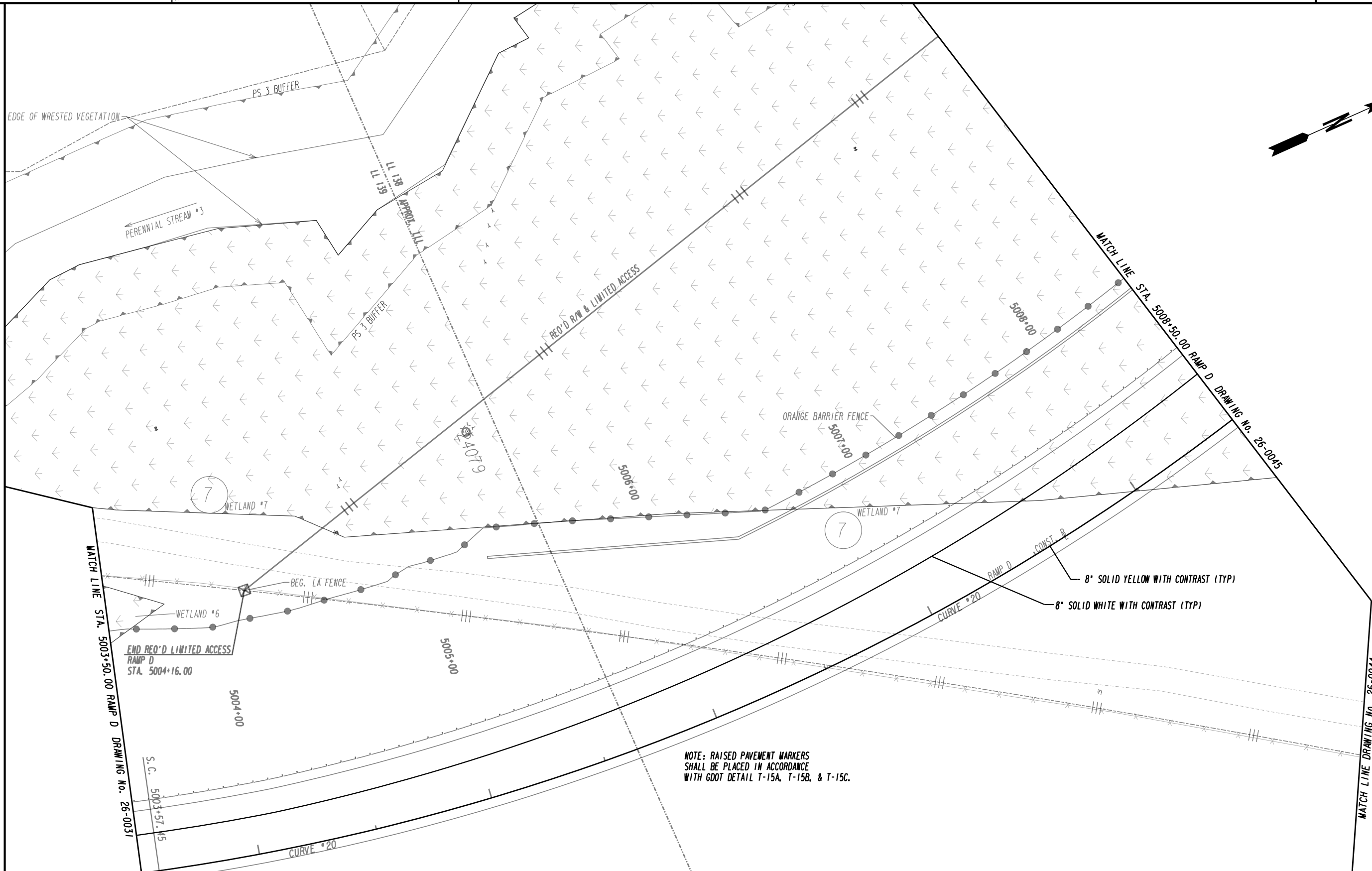

MATCH LINE STA. 5003+50.00 RAMP D DRAWING No. 26-0031

MATCH LINE DRAWING No. 26-0044

MATCH LINE STA. 5008+50.00 RAMP D DRAWING No. 26-0045

NOTE: RAISED PAVEMENT MARKERS SHALL BE PLACED IN ACCORDANCE WITH GDOT DETAIL T-15A, T-15B, & T-15C.

PROPERTY AND EXISTING R/W LINE
 REQUIRED R/W LINE
 CONSTRUCTION LIMITS
 EASEMENT FOR CONSTR
 & MAINTENANCE OF SLOPES
 EASEMENT FOR CONSTR OF SLOPES
 EASEMENT FOR CONSTR OF DRIVES
 PAVEMENT/MEDIAN REMOVAL

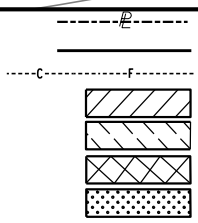

BEGIN LIMIT OF ACCESS.....BLA
 END LIMIT OF ACCESS.....ELA
 LIMIT OF ACCESS
 REQ'D R/W & LIMIT OF ACCESS
 ORANGE BARRIER FENCE
 ESA - ENV. SENSITIVE AREA
 (SEE ERIT TABLE)

PLANS PREPARED AND SUBMITTED BY:
 Branch Office
 O 65 Aberdeen Drive
 Georgia, KY 40341
 (270) 651-7220
 O 2500 Nelson Miller Parkway
 Louisville, KY 40223
 (502) 245-3813
AMERICAN ENGINEERS, INC.
 www.aei.cc DESIGN CONSULTANT PROFESSIONAL ENGINEERING

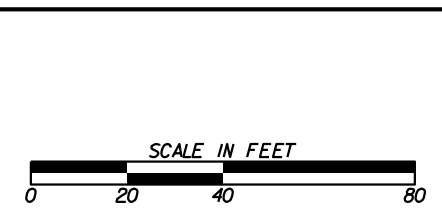

REVISION DATES	

SIGNING AND MARKING PLANS			
RAMP D			
CHECKED:		DATE:	
BACKCHECKED:		DATE:	
CORRECTED:		DATE:	
VERIFIED:		DATE:	
DRAWING No.			26-0046

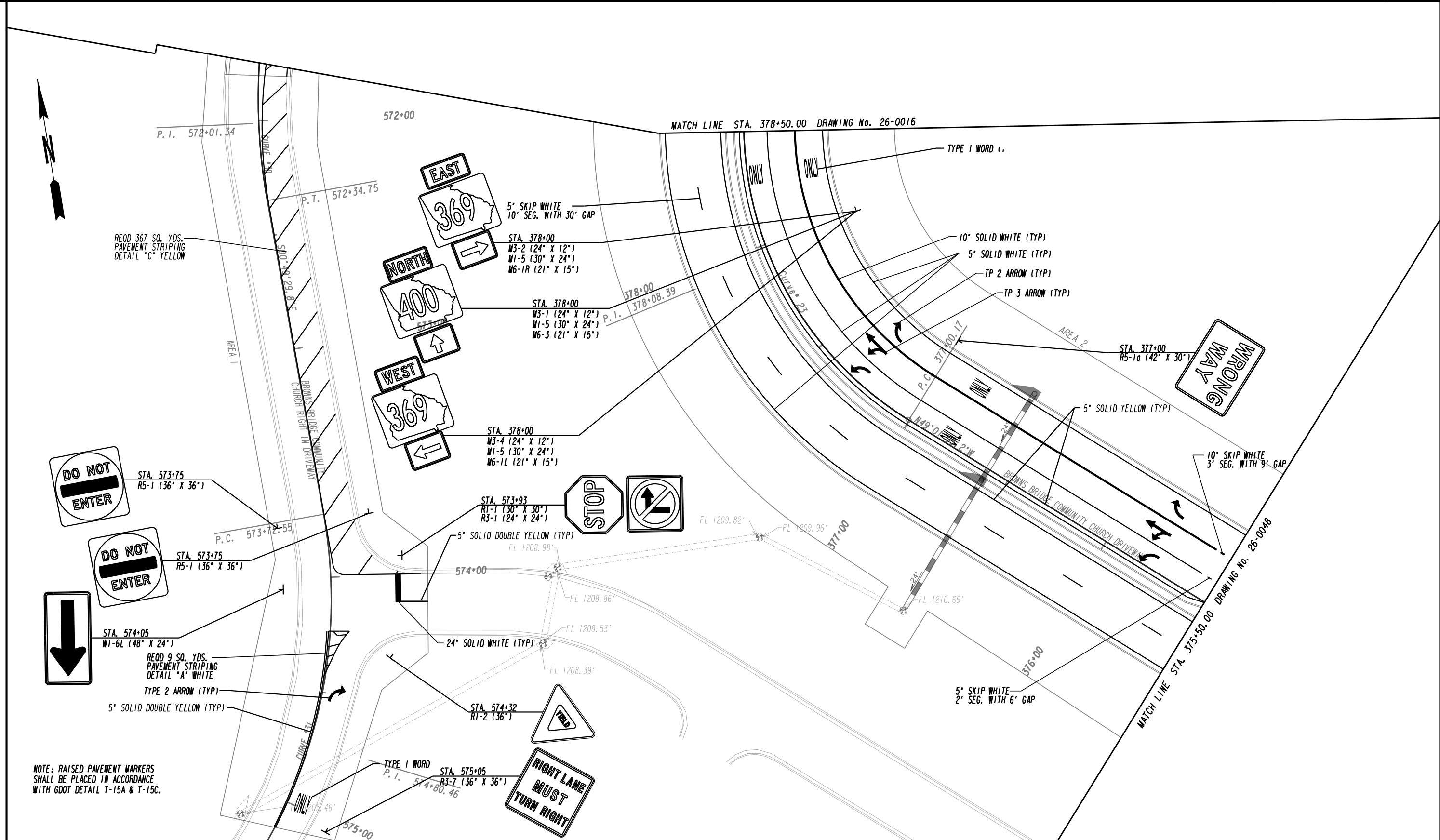

NOTE: RAISED PAVEMENT MARKERS SHALL BE PLACED IN ACCORDANCE WITH GDOT DETAIL T-15A & T-15C.

PROPERTY AND EXISTING R/W LINE	---
REQUIRED R/W LINE	---
CONSTRUCTION LIMITS	---
EASEMENT FOR CONSTR & MAINTENANCE OF SLOPES	---
EASEMENT FOR CONSTR OF SLOPES	---
EASEMENT FOR CONSTR OF DRIVES	---
PAVEMENT/MEDIAN REMOVAL	---

BEGIN LIMIT OF ACCESS.....BLA	---
END LIMIT OF ACCESS.....ELA	---
LIMIT OF ACCESS	---
REQ'D R/W & LIMIT OF ACCESS	---
ORANGE BARRIER FENCE	---
ESA - ENV. SENSITIVE AREA (SEE ERIT TABLE)	---

PLANS PREPARED AND SUBMITTED BY:

AEI
AMERICAN ENGINEERS, INC.
www.aei.cc

DESIGN CONSULTANT

PROFESSIONAL ENGINEERING

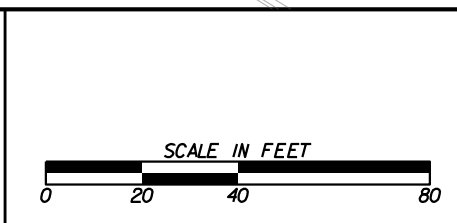

REVISION DATES	

SIGNING AND MARKING PLANS			
BROWNS BRIDGE COMMUNITY CHURCH DRIVEWAY			
CHECKED:	DATE:	DRAWING No.	
BACKCHECKED:	DATE:	26-0047	
CORRECTED:	DATE:		
VERIFIED:	DATE:		

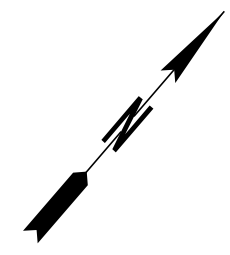
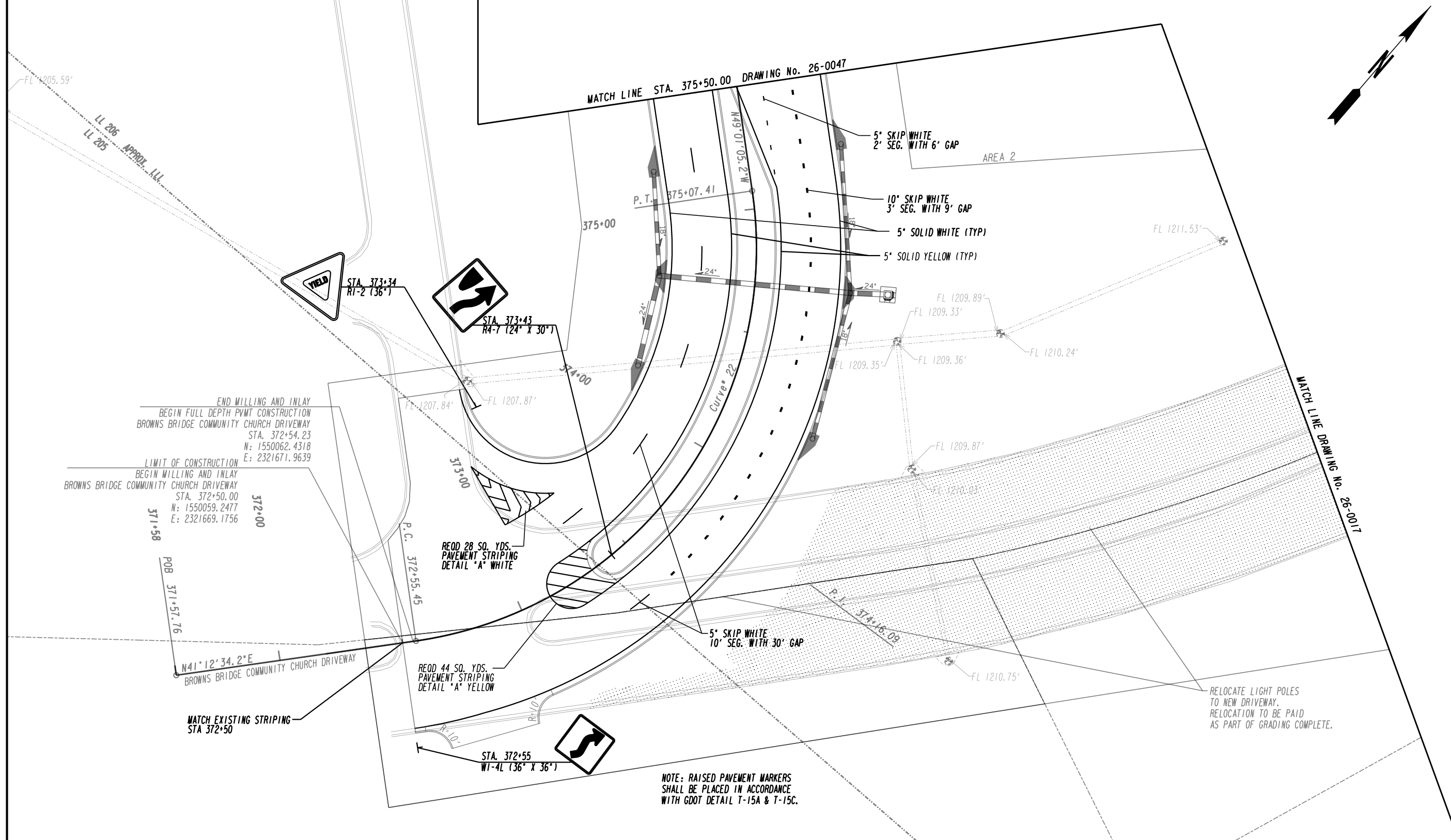

PROPERTY AND EXISTING R/W LINE
REQUIRED R/W LINE
CONSTRUCTION LIMITS
EASEMENT FOR CONSTR
& MAINTENANCE OF SLOPES
EASEMENT FOR CONSTR OF SLOPES
EASEMENT FOR CONSTR OF DRIVES
PAVEMENT/MEDIAN REMOVAL

BEGIN LIMIT OF ACCESS.....BLA
END LIMIT OF ACCESS.....ELA
LIMIT OF ACCESS
REQ'D R/W & LIMIT OF ACCESS
ORANGE BARRIER FENCE
ESA - ENV. SENSITIVE AREA
(SEE ERIT TABLE)

PLANS PREPARED AND SUBMITTED BY:

AEI
AMERICAN ENGINEERS, INC.
DESIGN CONSULTANT

PROFESSIONAL ENGINEERING

Branch Office:
65 Aberdeen Drive
Glasgow, KY 40424
(270) 651-7220

2500 Nelson Miller Parkway
Louisville, KY 40223
(502) 245-3813

1634 White Circle, Suite 101
Martinsburg, GA 30056
(770) 421-8422

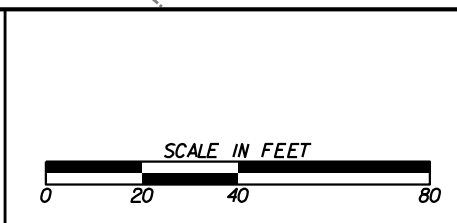

REVISION DATES

SIGNING AND MARKING PLANS

BROWNS BRIDGE COMMUNITY CHURCH DRIVEWAY

CHECKED:	DATE:	DRAWING No.
BACKCHECKED:	DATE:	26-0048
CORRECTED:	DATE:	
VERIFIED:	DATE:	

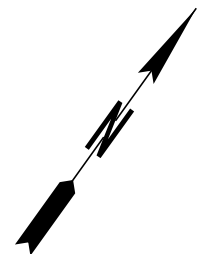
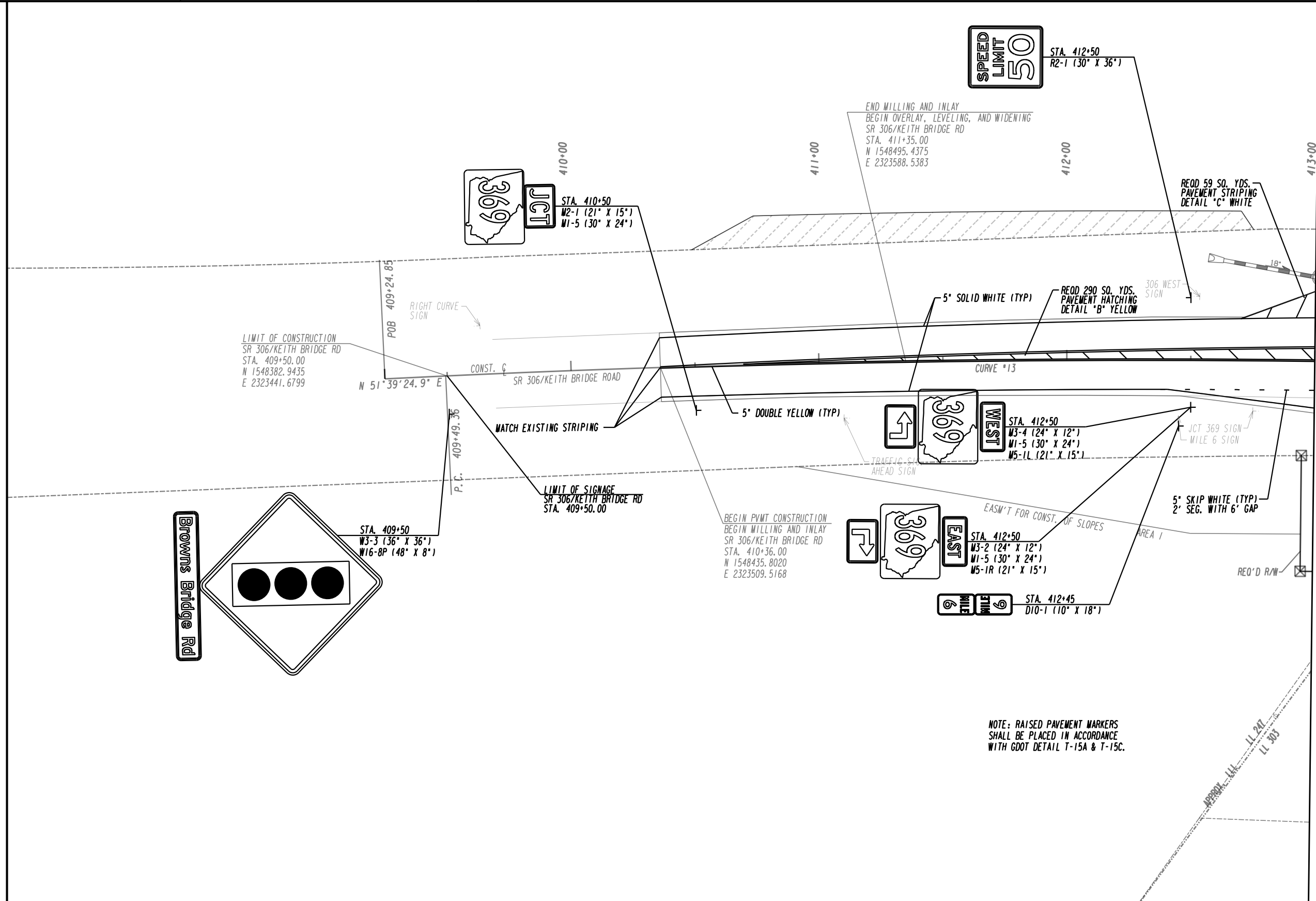

DRAWING No. 26-0050
MATCH LINE STA. 413+00.00

LIMIT OF CONSTRUCTION
SR 306/KEITH BRIDGE RD
STA. 409+50.00
N 1548382.9435
E 2323441.6799

LIMIT OF SIGNAGE
SR 306/KEITH BRIDGE RD
STA. 409+50.00

BEGIN PVMT CONSTRUCTION
BEGIN MILLING AND INLAY
SR 306/KEITH BRIDGE RD
STA. 410+36.00
N 1548435.8020
E 2323509.5168

END MILLING AND INLAY
BEGIN OVERLAY, LEVELING, AND WIDENING
SR 306/KEITH BRIDGE RD
STA. 411+35.00
N 1548495.4375
E 2323588.5383

NOTE: RAISED PAVEMENT MARKERS
SHALL BE PLACED IN ACCORDANCE
WITH GDOT DETAIL T-15A & T-15C.

PROPERTY AND EXISTING R/W LINE	---
REQUIRED R/W LINE	---
CONSTRUCTION LIMITS	---
EASEMENT FOR CONSTR & MAINTENANCE OF SLOPES	---
EASEMENT FOR CONSTR OF SLOPES	---
EASEMENT FOR CONSTR OF DRIVES	---
PAVEMENT/MEDIAN REMOVAL	---

BEGIN LIMIT OF ACCESS.....BLA	---
END LIMIT OF ACCESS.....ELA	---
LIMIT OF ACCESS	---
REQ'D R/W & LIMIT OF ACCESS	---
ORANGE BARRIER FENCE	---
ESA - ENV. SENSITIVE AREA (SEE ERIT TABLE)	---

PLANS PREPARED AND SUBMITTED BY:

AEI
AMERICAN ENGINEERS, INC.
DESIGN CONSULTANT

PROFESSIONAL ENGINEERING

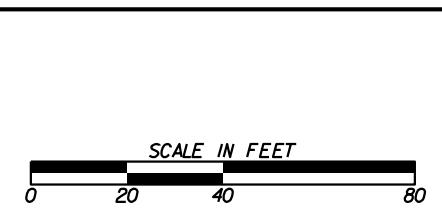

REVISION DATES	

SIGNING AND MARKING PLANS			
SR 306/KEITH BRIDGE RD			
CHECKED:		DATE:	
BACKCHECKED:		DATE:	
CORRECTED:		DATE:	
VERIFIED:		DATE:	
DRAWING No.			26-0049

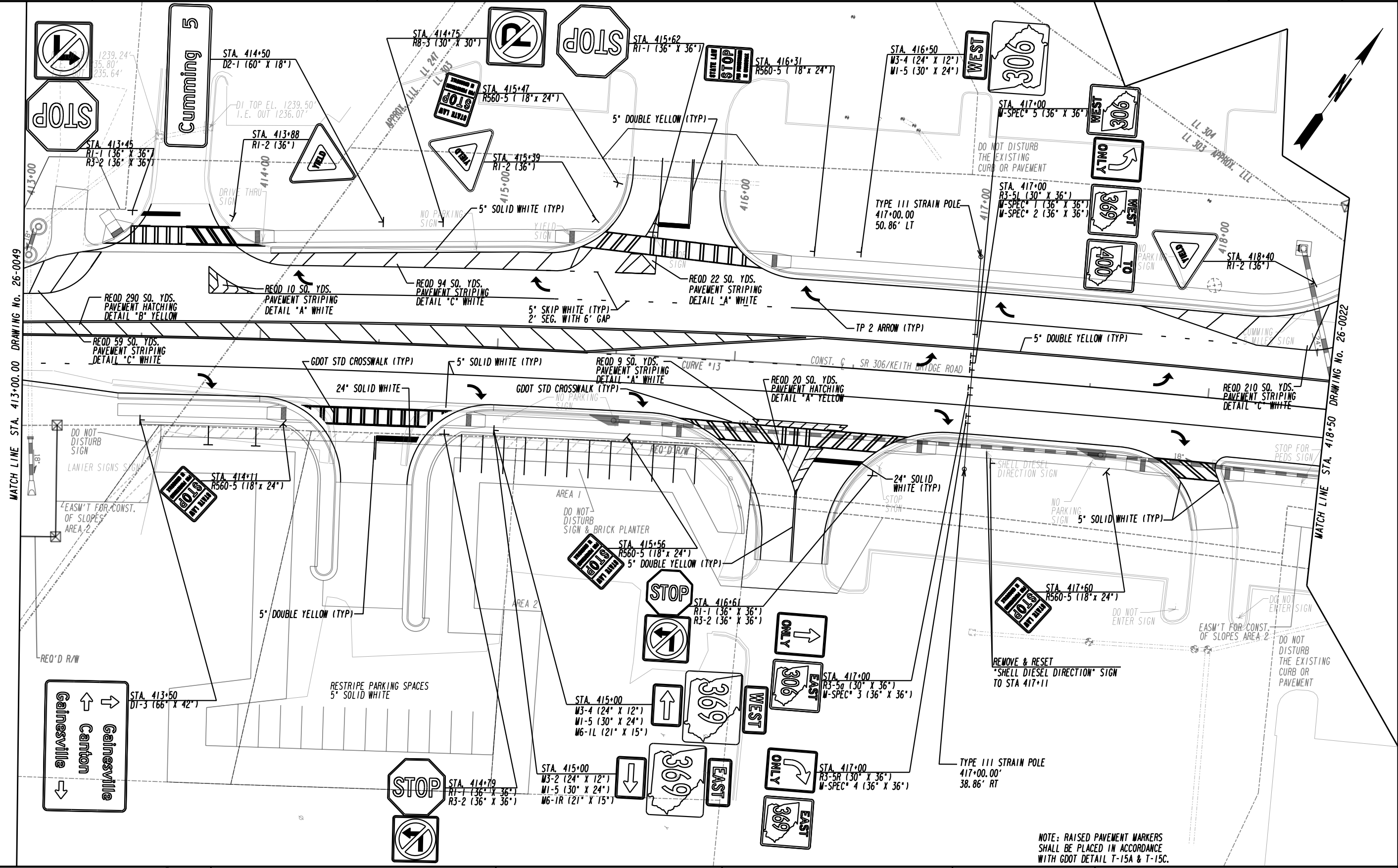

MATCH LINE STA. 413+00.00 DRAWING No. 26-0049

MATCH LINE STA. 418+50 DRAWING No. 26-0022

PROPERTY AND EXISTING R/W LINE	-----e-----
REQUIRED R/W LINE	-----f-----
CONSTRUCTION LIMITS	-----g-----
EASEMENT FOR CONSTR & MAINTENANCE OF SLOPES	-----h-----
EASEMENT FOR CONSTR OF SLOPES	-----i-----
EASEMENT FOR CONSTR OF DRIVES	-----j-----
PAVEMENT/MEDIAN REMOVAL	-----k-----

BEGIN LIMIT OF ACCESS.....BLA	-----l-----
END LIMIT OF ACCESS.....ELA	-----m-----
LIMIT OF ACCESS	-----n-----
REQ'D R/W & LIMIT OF ACCESS	-----o-----
ORANGE BARRIER FENCE	-----p-----
ESA - ENV. SENSITIVE AREA (SEE ERIT TABLE)	-----q-----

PLANS PREPARED AND SUBMITTED BY:

AEI

AMERICAN ENGINEERS, INC.

DESIGN CONSULTANT

PROFESSIONAL ENGINEERING

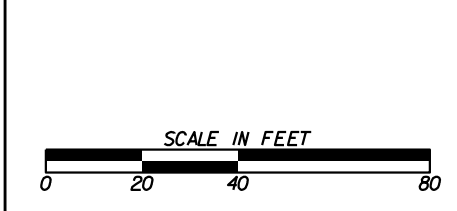

REVISION DATES	

SIGNING AND MARKING PLANS			
SR 306/KEITH BRIDGE RD			
CHECKED:		DATE:	
BACKCHECKED:		DATE:	
CORRECTED:		DATE:	
VERIFIED:		DATE:	
DRAWING No.			26-0050

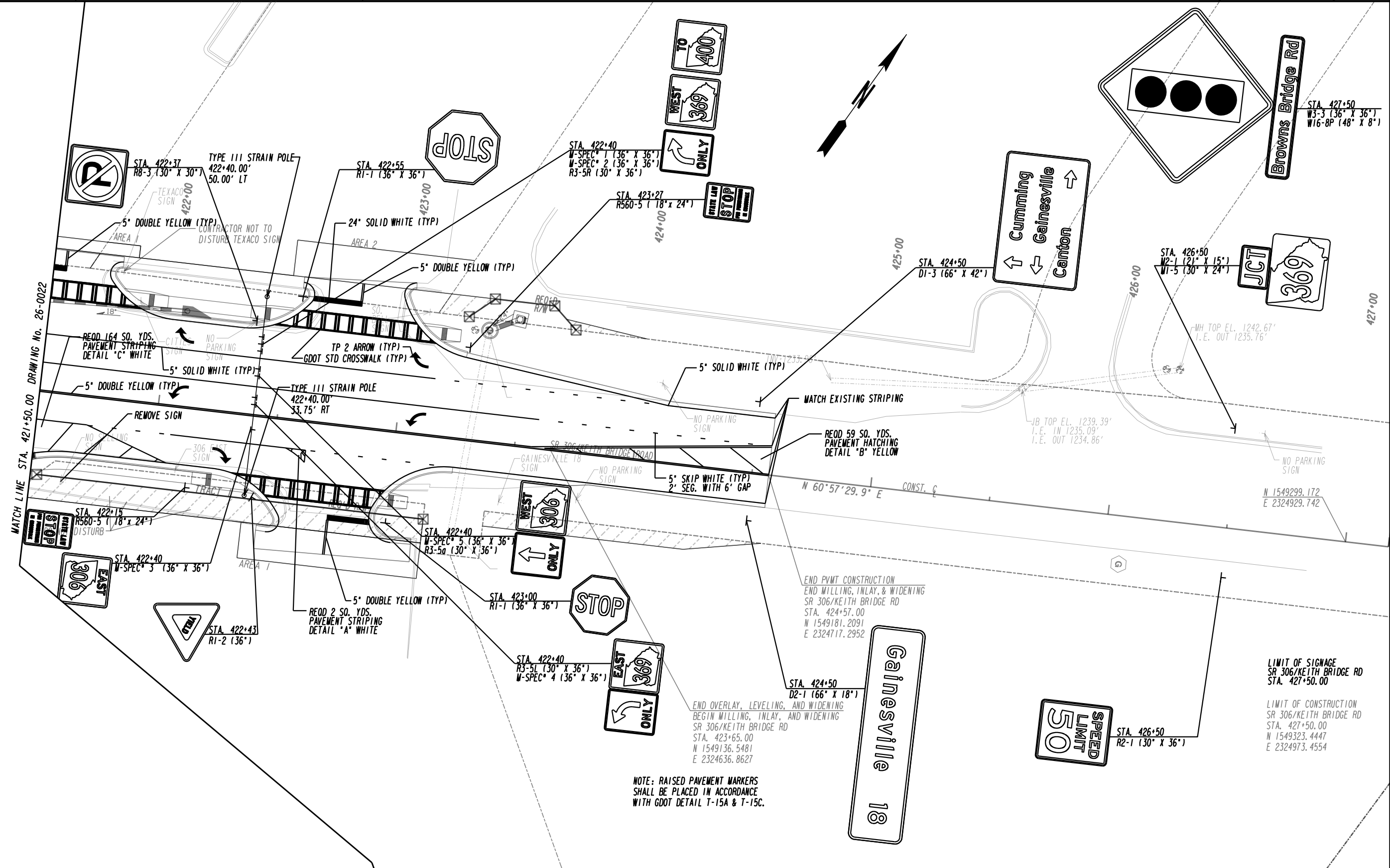

NOTE: RAISED PAVEMENT MARKERS SHALL BE PLACED IN ACCORDANCE WITH GOOT DETAIL T-15A & T-15C.

PROPERTY AND EXISTING R/W LINE	---
REQUIRED R/W LINE	---
CONSTRUCTION LIMITS	---
EASEMENT FOR CONSTR & MAINTENANCE OF SLOPES	---
EASEMENT FOR CONSTR OF SLOPES	---
EASEMENT FOR CONSTR OF DRIVES	---
PAVEMENT/MEDIAN REMOVAL	---

BEGIN LIMIT OF ACCESS.....BLA	---
END LIMIT OF ACCESS.....ELA	---
LIMIT OF ACCESS	---
REQ'D R/W & LIMIT OF ACCESS	---
ORANGE BARRIER FENCE	---
ESA - ENV. SENSITIVE AREA (SEE ERIT TABLE)	---

PLANS PREPARED AND SUBMITTED BY:

AEI

AMERICAN ENGINEERS, INC.

DESIGN CONSULTANT

PROFESSIONAL ENGINEERING



REVISION DATES	

SIGNING AND MARKING PLANS			
SR 306/KEITH BRIDGE RD			
CHECKED:		DATE:	
BACKCHECKED:		DATE:	
CORRECTED:		DATE:	
VERIFIED:		DATE:	
DRAWING No.			26-0051

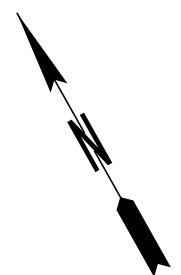

PROPERTY AND EXISTING R/W LINE	---
REQUIRED R/W LINE	---
CONSTRUCTION LIMITS	---
EASEMENT FOR CONSTR & MAINTENANCE OF SLOPES	---
EASEMENT FOR CONSTR OF SLOPES	---
EASEMENT FOR CONSTR OF DRIVES	---
PAVEMENT/MEDIAN REMOVAL	---

BEGIN LIMIT OF ACCESS.....BLA	---
END LIMIT OF ACCESS.....ELA	---
LIMIT OF ACCESS	---
REQ'D R/W & LIMIT OF ACCESS	---
ORANGE BARRIER FENCE	---
ESA - ENV. SENSITIVE AREA (SEE ERIT TABLE)	---

PLANS PREPARED AND SUBMITTED BY:

AEI
AMERICAN ENGINEERS, INC.
DESIGN CONSULTANT

PROFESSIONAL ENGINEERING

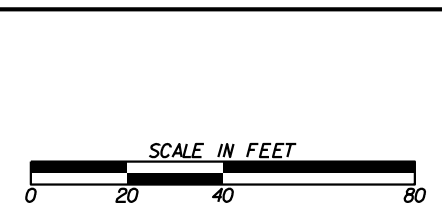

REVISION DATES	

SIGNING AND MARKING PLANS			
MOBIL GAS STATION DRIVEWAY			
CHECKED:	DATE:	DRAWING No.	
BACKCHECKED:	DATE:	26-0052	
CORRECTED:	DATE:		
VERIFIED:	DATE:		

STRUCTURAL SUPPORT * J362
TYPE I STRUCTURE
TO N 1546703.8128
E 2318792.7222
400 NB



SR 400 SB

LIMIT OF CONSTRUCTION
US 19/SR 400
N 1546451.1721
E 2318781.4973

SR 400 NB

INSTALL
OVERHEAD SIGN
STRUCTURAL SUPPORT * J362
TYPE I STRUCTURE
TO N 1546681.5040
E 2318863.8430
400 NB
SEE SHEET 26-057

SPEC * 101
(318" X 204")
E1-5P
(114" X 30")

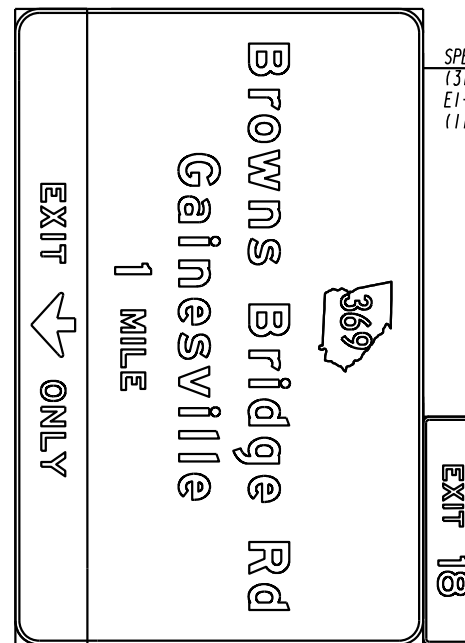

PROPERTY AND EXISTING R/W LINE
REQUIRED R/W LINE
CONSTRUCTION LIMITS
EASEMENT FOR CONSTR
& MAINTENANCE OF SLOPES
EASEMENT FOR CONSTR OF SLOPES
EASEMENT FOR CONSTR OF DRIVES
PAVEMENT/MEDIAN REMOVAL

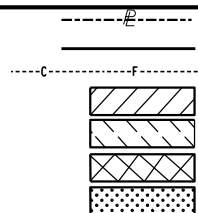

BEGIN LIMIT OF ACCESS.....BLA
END LIMIT OF ACCESS.....ELA
LIMIT OF ACCESS
REQ'D R/W & LIMIT OF ACCESS
ORANGE BARRIER FENCE
ESA - ENV. SENSITIVE AREA
(SEE ERIT TABLE)

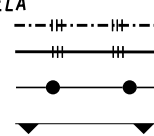

PLANS PREPARED AND SUBMITTED BY:
Branch Offices
O 65 Aberdeen Drive
Glasgow, KY 42401
(270) 651-1220
O 2500 Nelson Miller Parkway
Louisville, KY 40223
(502) 245-385
AMERICAN ENGINEERS, INC.
www.aei.com
DESIGN CONSULTANT
PROFESSIONAL ENGINEERING
Branch Office
O 1634 White Circle, Suite 101
Marietta, GA 30066
(770) 421-8422

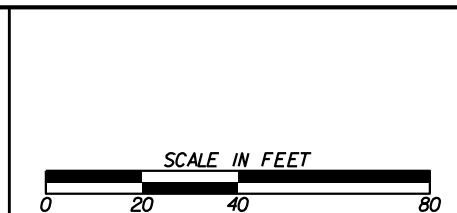

REVISION DATES

NO.	DATE	DESCRIPTION

SIGNING AND MARKING PLANS

SR 400/US 19

CHECKED:	DATE:	DRAWING No.
		26-0053
BACKCHECKED:	DATE:	
CORRECTED:	DATE:	
VERIFIED:	DATE:	

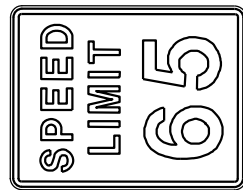

STA. 1010+30
R2-1 (36" X 48")

BOX CULVERT
4'W X 5'H
INV. 1147.67'

REFLECTOR
SIGN

INSTALL
OVERHEAD SIGN STA 1010+60.00
STRUCTURAL SUPPORT * J367
TYPE I STRUCTURE
TO STA 1010+60, 4.69' RT
400 NB
SPEC * 102 (318" X 204")
SEE SHEET 26-058

Browns Bridge Rd
Gainesville

1/2 MILE

EXIT ONLY

369

EXIT 18

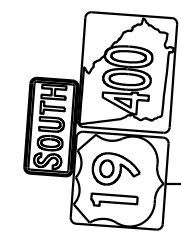

STA. 1015+30
W3-3 (36" X 18")
W1-4 (36" X 36")
W1-5 (45" X 36")



1010+00

00+101

1012+00

1013+00

1014+00

1015+00

SR 400 SB

SR 400 NB

N 17°28'29.7" E

P.C. 1011+12.24

TP 13 WORD (TYP)

DI
TOP 1165.59'
INV UNOBTAINABLE

INSTALL
OVERHEAD SIGN STA 1010+60.00
STRUCTURAL SUPPORT * J367
TYPE I STRUCTURE
TO STA 1010+60, 90.85' RT
400 NB
SPEC * 102 (318" X 204")
SEE SHEET 26-058

18" CMP
INV. 1145.23'

BOX CULVERT
4'W X 5'H
INV. 1145.87'

TRIPLE BOX CULVERT
6'H X 6'W BOXES
INV. 1144.79'

INV. 1167.14'
INV. 1157.77'

PROPERTY AND EXISTING R/W LINE
REQUIRED R/W LINE
CONSTRUCTION LIMITS
EASEMENT FOR CONSTR
& MAINTENANCE OF SLOPES
EASEMENT FOR CONSTR OF SLOPES
EASEMENT FOR CONSTR OF DRIVES
PAVEMENT/MEDIAN REMOVAL

---	---
---	---
---	---
---	---
---	---
---	---
---	---
---	---
---	---
---	---

BEGIN LIMIT OF ACCESS.....BLA
END LIMIT OF ACCESS.....ELA
LIMIT OF ACCESS
REQ'D R/W & LIMIT OF ACCESS
ORANGE BARRIER FENCE
ESA - ENV. SENSITIVE AREA
(SEE ERIT TABLE)

---	---
---	---
---	---
---	---
---	---
---	---
---	---
---	---
---	---
---	---

PLANS PREPARED AND SUBMITTED BY:

AEI

AMERICAN ENGINEERS, INC.
DESIGN CONSULTANT

PROFESSIONAL ENGINEERING

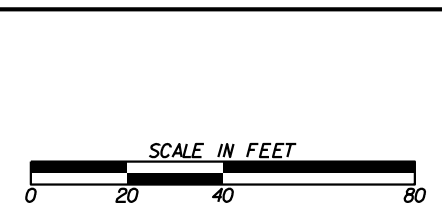

REVISION DATES

SIGNING AND MARKING PLANS

SR 400/US 19

CHECKED:		DATE:		DRAWING No.
BACKCHECKED:		DATE:		26-0054
CORRECTED:		DATE:		
VERIFIED:		DATE:		

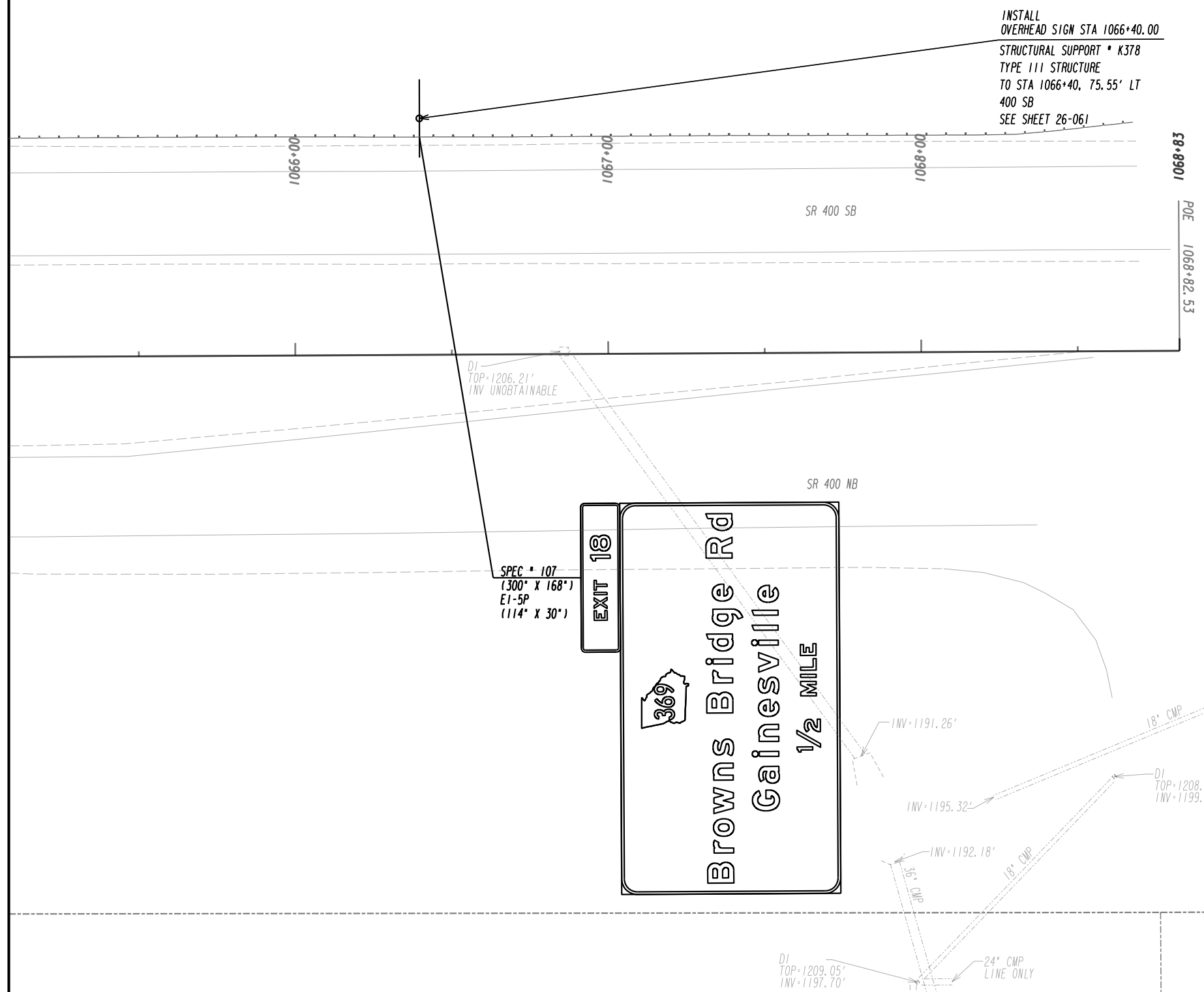
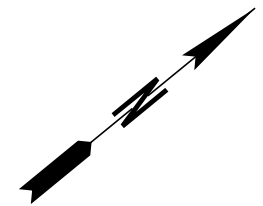

PROPERTY AND EXISTING R/W LINE	---
REQUIRED R/W LINE	---
CONSTRUCTION LIMITS	---
EASEMENT FOR CONSTR & MAINTENANCE OF SLOPES	---
EASEMENT FOR CONSTR OF SLOPES	---
EASEMENT FOR CONSTR OF DRIVES	---
PAVEMENT/MEDIAN REMOVAL	---

BEGIN LIMIT OF ACCESS.....BLA	---
END LIMIT OF ACCESS.....ELA	---
LIMIT OF ACCESS	---
REQ'D R/W & LIMIT OF ACCESS	---
ORANGE BARRIER FENCE	---
ESA - ENV. SENSITIVE AREA (SEE ERIT TABLE)	---

PLANS PREPARED AND SUBMITTED BY:

AEI
AMERICAN ENGINEERS, INC.
DESIGN CONSULTANT

PROFESSIONAL ENGINEERING

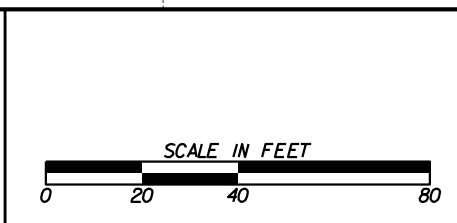

REVISION DATES	

SIGNING AND MARKING PLANS			
SR 400/US 19			
CHECKED:		DATE:	
BACKCHECKED:		DATE:	
CORRECTED:		DATE:	
VERIFIED:		DATE:	
DRAWING No.			26-0055

