



Installation Instructions

JG205.XXX.590663

Force Measuring Journal, hermetically sealed with stainless steel gaiter

Document Version 1.00
Issue Date / Author 11/2020 / NS



**Diese Bedienungsanleitung ist auch in Deutsch erhältlich.
Bitte kontaktieren Sie Ihre nächstgelegene FMS Vertretung.**

1 Table of contents

1	TABLE OF CONTENTS	2
2	SAFETY INSTRUCTIONS.....	3
2.1	Presentation of safety information	3
2.1.1	Danger that could result in minor or moderate injuries.....	3
2.1.2	Note regarding proper function	3
2.2	General safety information	3
3	PRODUCT INFORMATION.....	4
3.1	Scope of Delivery	4
3.2	Functional Description.....	4
4	INSTALLATION.....	5
4.1	Installation conditions.....	5
4.2	Preparing the Machine Frame	5
4.3	Installation of the Force Sensor	5
4.3.1	Fixed Bearing Side	5
4.3.2	Floating Bearing side	6
4.4	Electrical connections	6
4.5	Maintenance / Disassembly	6
4.5.1	Maintenance	6
4.5.2	Disassembly.....	6
4.6	Dimensions	7
5	TECHNICAL DATA.....	8

2 Safety instructions

All safety related regulations, local codes and instructions that appear in the manual or on equipment must be observed to ensure personal safety and to prevent damage to the equipment connected to it. If equipment is used in a manner not specified by the manufacturer, the protection provided by the equipment may be impaired.

Do not stress the equipment over the specification limits neither during assembly nor operation. To do so can be potentially harmful to persons or equipment in the event of a fault to the equipment.

2.1 Presentation of safety information

The following safety symbols appear in this manual.

2.1.1 Danger that could result in minor or moderate injuries



Danger, warning, caution

Failure to follow wiring instructions in this manual may result in equipment damage or personal injury.

2.1.2 Note regarding proper function



Note

Note regarding proper operation
Simplification of operation
Ensuring function

2.2 General safety information



The Force Sensor may not be stressed over the specification limits neither during assembly nor operation. The unit's overload protection value may not be exceeded.



The attachment points for the Force Sensor on the machine frame must be properly designed. The bearings need to be appropriately mounted.



For proper installation and operation, follow the electrical wiring diagram and instructions in this manual.

3 Product Information

3.1 Scope of Delivery

For the purpose of the device protection the force measuring journal uses a highly sealing PG-gland as an electrical connector. The cable length can be determined by the customer. The sensor is delivered with a 5.0 m cable. Mounting screws and other mounting devices are not in the scope of delivery

3.2 Functional Description

Foil type strain gauges mounted in a full Wheatstone bridge configuration in each sensor perform the actual tension measurement. The dual flexion beam design eliminates angular deflection and load dependent torque effects. It ensures tension measurement with the highest accuracy and reliability under the most stringent requirements. A built in mechanical hard-stop provides high overload protection and ensures that frequent calibration is not required.

This sensor owes its high protection class (IP68) to a hermetically soldered stainless steel gaiter and a glass sealed PG-gland. It is therefore ideally suited to work in difficult ambient conditions, where the exposure to cooling water, rolling oils high temperatures and humidity is a factor.

4 Installation

4.1 Installation conditions

The Force Sensors are defined as “partly completed machinery” according to the Directives 2006/42/EC, article 2. In order to assure a proper functionality of the parts and assure the essential safety requirements of operators working with it, the following conditions for the assembly must be met:



The Force Measuring Rollers may not be stressed over the specification limits neither during assembly nor operation. The unit's overload protection value may not be exceeded.



The mounting points for the Force Measuring Rollers on the machine frame must be properly designed. The bearings need to be appropriately mounted.



For proper installation and operation, follow the electrical wiring diagram and instructions in this manual.

4.2 Preparing the Machine Frame

The force measuring journal is supported by a shaft of 23.7 mm diameter. The machine frame must therefore be prepared to accept this shaft diameter. If the force acts in the direction of the red point, a positive force reading will be reflected by the measuring amplifier output.

4.3 Installation of the Force Sensor

After having prepared the machine frame for the force measuring roller, the assembly is carried out in the follow steps:

- Have your mounting material (screws and washers) ready
- Determine the assembly points and prepare for a fixed and floating bearing arrangement
- Mount the fixed bearing side of the roller
- Mount the floating bearing side of the roller
- Assembly the roller into machine
- Connect the force measuring journals to the amplifier

4.3.1 Fixed Bearing Side

Clean the shaft and bearing seat of Force Measuring Journal and grease it slightly.

Mount your bearing system on it. On this side of the measuring roller the bearing can be fixed avoiding lateral movement.

4.3.2 Floating Bearing side

Clean the shaft and bearing seat of Force Measuring Journal and grease it slightly.

Mount your bearing system on it. The bearing on the floating side may not be fixed. The bearing must be allowed to move laterally to avoid restrain, angular deflection and load dependent torque effects

4.4 Electrical connections

Connection between the Force Measuring Journal and amplifier or controller is done by means of a 2x2x0.25mm² [AWG 23] shielded twisted-pair cable.

This cable must be installed away from power cables.

The wiring must be realized according to diagram. The current sensors are wired with following colour/signal combination:

A (brown) = +signal	B (green) = -excitation
C (yellow) = +excitation	D (white) = -signal

The shield should be connected only to the measuring amplifier. Consult also the wiring instructions of your Force Measuring Amplifier.

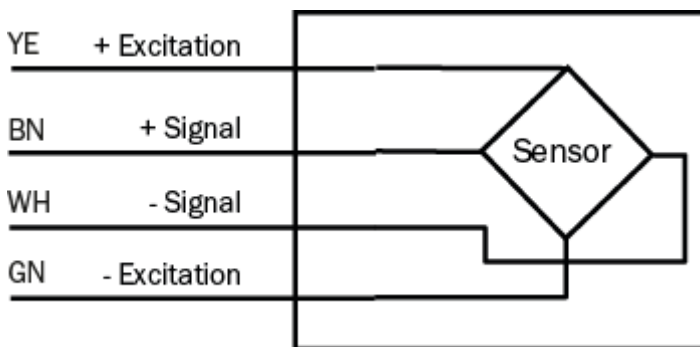

Figure 1: electrical connection *Pin_Assignment_Sensorkabel_Farben_Stecker.ai*



This cable must be installed away from power cables.

4.5 Maintenance / Disassembly

4.5.1 Maintenance

All FMS Force Measuring Sensors are maintenance-free. Depending on the type of bearing used, it may be necessary to periodically lubricate the bearings.

4.5.2 Disassembly

The disassembly of the Force Measuring Sensors is done by reversing the order of the assembly procedure.

Note



Despite of all reasonable precautions the self-aligning ball bearings could be damaged when pulled-off from the shaft. This could occur specially after a long service time. FMS therefore recommends the replacement of bearings whenever they are removed.

4.6 Dimensions

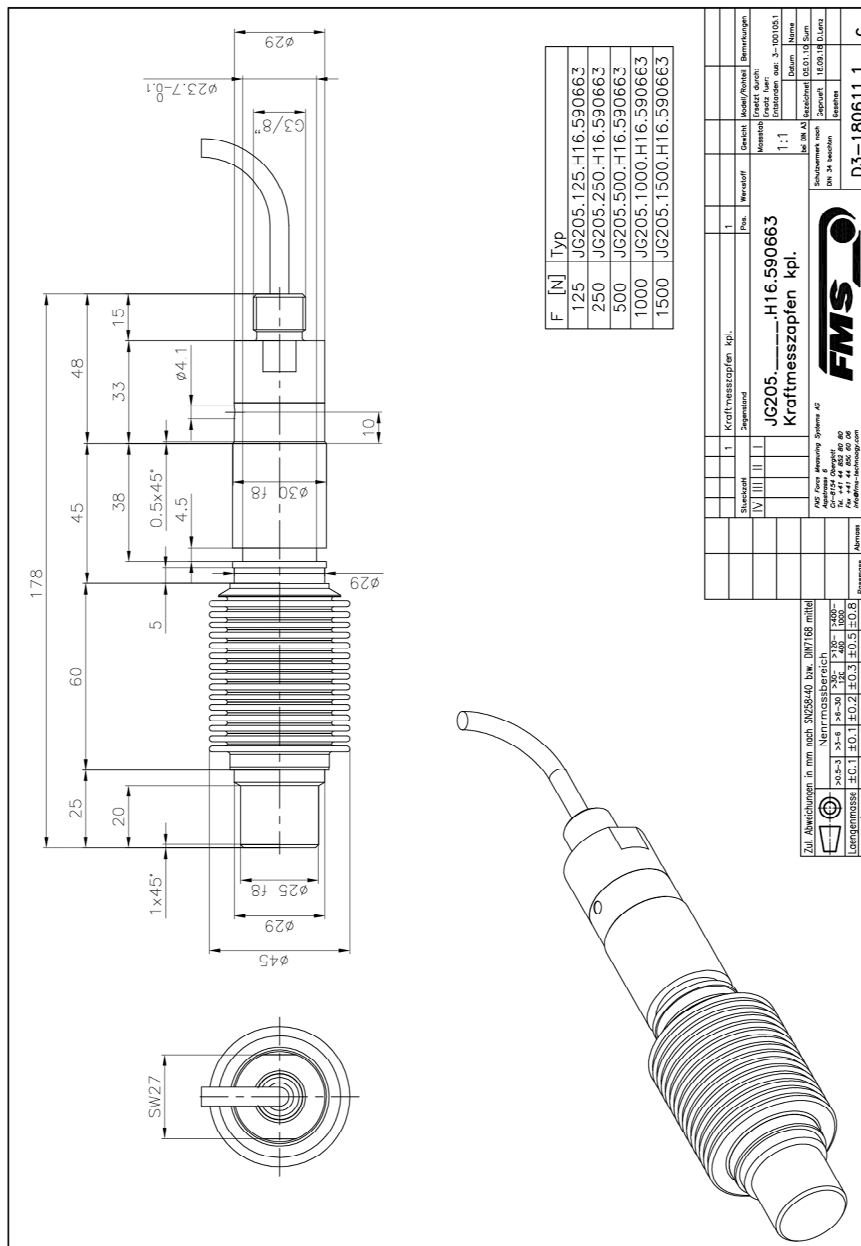

Figure 2: Dimensions

JG_205_590663_BA_Manual.ai

5 Technical data

Technical data	
Order Codes	Nominal Force
JG205.500.H16.590663	500 N
JG205.1500.H16.590663	1500 N
Protection class	IP68
Temperature range	-30 to +150 °C
Accuracy class	±0.5% (F_{Nominal})
Temperature coefficient	±0.1% / 10K
Overload protection	10-times nominal force
Electrical connection	Pg-gland
Weight	0.78 kg [1.7 lbs]
Material	Stainless Steel
Supply voltage (excitation)	1 to 10 VDC



FMS Force Measuring Systems AG
 Aspstrasse 6
 8154 Oberglatt (Switzerland)
 Tel. 0041 1 852 80 80
 Fax 0041 1 850 60 06
 info@fms-technology.com
 www.fms-technology.com

FMS USA, Inc.
 2155 Stonington Avenue
 Suite 119
 Hoffman Estates,, IL 60169
 (USA)
 Tel. +1 847 519 4400
 Fax +1 847 519 4401
 fmsusa@fms-technology.com

FMS (UK)
 Aspstrasse 6
 8154 Oberglatt (Switzerland)
 Tel. +44 (0)1767 221 303
 fmsuk@fms-technology.com

FMS (Italy)
 Aspstrasse 6
 8154 Oberglatt (Switzerland)
 Tel. +39 02 39487035
 fmsit@fms-technology.com