



Pompes d'Égout Vortex

Séries FBV

Opération, Maintenance
& Manuel d'Installation



Séries FBV 322/337/437
CMLU

www.flofab.com

001-iom-2018-fbvfr

1. SERVICE ET GARANTIE

Si vous ne pouvez trouver la raison du problème, consultez votre vendeur local ou la compagnie où vous avez fait l'achat de la pompe. La pompe est garantie 1 an à partir de la date d'achat. Une preuve d'achat est requise pour pouvoir procéder à toutes réparations.

2. SPÉCIFICATIONS TECHNIQUES

Models Modèles	Outlet Sortie		Elec. Motor Moteur élec.			Voltage / Phase / HZ	Solid Pass Passer des solides		Weight Poids	
	mm mm	in po	Hp Hp	Amp. / Amp.			mm mm	in po	kg kg	Lb Lb
				Start Départ	Run Opération					
FBV-322-3-2.2	80	3	2	40.5	9.52	208/3/60	76	3	50	110
FBV-322-3-2.2	80	3	2	41.2	8.7	230/3/60	76	3	50	110
FBV-322-3-2.2	80	3	2	30.5	4.2	460/3/60	76	3	50	110
FBV-322-3-2.2	80	3	2	21	4.1	480/3/60	76	3	50	110
FBV-322-3-2.2	80	3	2	12	3.42	575/3/60	76	3	50	110
FBV-337-5-2.2	80	3	3	58	15.8	208/3/60	76	3	54	119
FBV-337-5-2.2	80	3	3	60	13	230/3/60	76	3	54	119
FBV-337-5-2.2	80	3	3	35	7	460/3/60	76	3	54	119
FBV-337-5-2.2	80	3	3	32	6.8	480/3/60	76	3	54	119
FBV-337-5-2.2	80	3	3	25	5.7	575/3/60	76	3	54	119
FBV-437-5-2.2	100	4	3	58	15.8	208/3/60	76	3	54	119
FBV-437-5-2.2	100	4	3	60	13	230/3/60	76	3	54	119
FBV-437-5-2.2	100	4	3	35	7	460/3/60	76	3	54	119
FBV-437-5-2.2	100	4	3	32	6.8	480/3/60	76	3	54	119
FBV-437-5-2.2	100	4	3	25	5.7	575/3/60	76	3	54	119

3. RÉOLUTION DE PROBLÈMES

POUR PRÉVENIR DES ACCIDENTS GRAVES, DÉBRANCHER LA SOURCE D'ALIMENTATION AVANT L'INSPECTION DE LA POMPE:

Malfunctionnement	Raison(s)	Contre mesure(s)
La pompe ne démarre pas	Il n'y a pas de courant à la pompe	Contactez votre fournisseur d'électricité ou un électricien
	Circuit ouvert ou connection pauvre du câble cabtyre	Vérifier s'il y a un circuit ouvert dans le câble cabtyre ou dans les fils
	L'impulseur est obstrué	Inspecter la pompe et enlever l'obstruction
La pompe démarre, mais arrête immédiatement, entraînant la réaction de la fonction de protection du moteur	L'impulseur est obstrué	Inspecter la pompe et enlever l'obstruction
	Le voltage diminue	Corriger le voltage au bon voltage, ou utiliser un câble d'extension qui est conforme aux normes
	Un modèle 50 Hz fonctionne à 60Hz	Vérifier l'étiquette et remplacer la pompe ou l'impulseur
	Le tamis est obstrué et la pompe a fonctionner à sec pendant plusieurs heures	Enlever l'obstruction
	Le moteur est anormal	Réparer le moteur ou le remplacer par un nouveau
	La pompe ramasse trop de sédiments (dépôts)	Placer un bloc de ciment sous la pompe pour prévenir le ramassage de sédiments
La tête de la pompe et le volume de succion sont trop bas	L'impulseur est usé	Remplacer
	Le tuyau est peut-être bouché	Minimiser le nombre de coude du tuyau. Dans un endroit où il y a beaucoup de débris, utiliser la pompe dans un panier à maille
	Le tamis est obstrué ou enseveli	Enlever l'obstruction.
	Le moteur tourne dans le sens inverse	Interchanger les connections des terminals de la source d'alimentation
La pompe génère des bruits et des vibrations	Le support du moteur est peut-être endommagé	Pour remplacer ce support, contactez la compagnie où vous avez acheter l'équipement.

4. ÉTAPES PRÉ-OPÉRATOIRE

- 1.1. S'assurer d'avoir une bonne mise à terre, et installer le fusible à fuite pour prévenir les utilisateurs de se faire électrocuter.
- 1.2. S'assurer que le voltage de la source d'alimentation est identique à celui de l'étiquette de la pompe. Ne pas brancher à un voltage et/ou phase différent celle de l'étiquette.
- 1.3. Ne pas utiliser à l'air libre sans eau, cela pourrait endommager la pompe.
- 1.4. Ne pas utiliser le câble électrique pour transporter, lever ou abaisser la pompe. Utiliser plutôt la poignée destinée à cet effet.

1.5. **Extension du câble d'alimentation:**

Lorsque le câble d'alimentation doit être allongé par un câble d'extension, choisir la bonne grandeur de câble selon la longueur à couvrir. Si le câble est trop long, une baisse de voltage surviendra, ce qui fera en sorte que le moteur cessera de tourner, ce qui endommagera la pompe.

NE PAS UTILISER LA POMPE DANS UN ENVIRONNEMENT EXPLOSIF ET/OU TOUT AUTRE ENDROIT OÙ IL POURRAIT Y AVOIR DES GENS, DES ACCIDENTS GRAVES POURRAIENT SURVENIR.

5. ENTRETIEN LORS DE L'OPÉRATION

- 2.1. **Lorsque la pompe arrête subitement (par la fonction de protection du moteur) :**
La fonction de protection du moteur est intégrée et est faite en sorte qu'elle arrête automatiquement le circuit, pour prévenir une surchauffe du moteur, lorsque celui-ci est surchargé due à une obstruction de particules externes, ou lorsqu'il est branché dans la mauvaise source d'alimentation (voltage, fréquence, etc.). La fonction de protection s'arrête toujours automatiquement en quelques secondes, si une anomalie survient. Si la pompe arrête subitement, vérifier les tuyaux, la pompe, les connections du câble à la source d'alimentation, etc. Vous pouvez ensuite repartir la pompe après avoir réglé le problème.
- 2.2. S'il vous plait, consulter votre vendeur local ou la compagnie où vous avez fait l'achat de votre pompe si vous êtes incapable de résoudre le problème encourru. Il est déconseillé de faire assembler ou désassembler la pompe par du personnel non-autorisé, car ceci pourrait entraîner des conséquences néfastes pour la pompe ou le moteur.

6. ENTRETIEN APRÈS L'OPÉRATION

VOUS N'ÊTES PAS OBLIGER D'ENTREtenir DÉSOBLIGÉMENT LA POMPE APRÈS SES OPÉRATIONS, MAIS TOUTEFOIS, VOUS DEVEZ PRENDRE CONSCIENCE DES POINTS SUIVANTS:

- 3.1. Si des températures très froides sont prévues, enlever la pompe et la mettre dans un endroit sec.
- 3.2. Si la pompe est laissée sans fonctionner durant une longue période de temps, la rouille et autres particules pourraient s'accumuler dans la pompe, ce qui entraînera inévitablement une réduction de la durée de vie de la pompe.

7. APPLICATION

LE PRODUIT LE PLUS EFFICACE, LE PLUS VERSATILE ET LE PLUS RENTABLE QUE VOUS AUREZ LA CHANCE D'UTILISER!

- Traitement des eaux pour filtration.
- Drainage sanitaire et de bâtiment.
- Drainage pluvial.

8. LISTE DES PIÈCES

Parts List

NO.	Description	Material
01	Outlet	FC-20
02	Cable Gland	NBR
04	Upper Cover	FC-20
06	Pump casing	FC-20
07	Bearing bracket	FC-20
10	Inlet Plate	FC-20
11	Strainer	SUS-304
13	Shaft	SUS-410
20	Handle	SUS-304
21	Motor frame	FC-20
25	Mech. Seal	SiC/SiC CE/CA
26	Bearing	6306ZZ-C3
26A	Bearing	6304ZZ-C3
27	Protector	
32	Cable	VCT
39	Impeller	FCDS0
76	Bearing disc	FC-20

AFECTMN FBV-322/337/437
Sectional Dwg &
Parts List

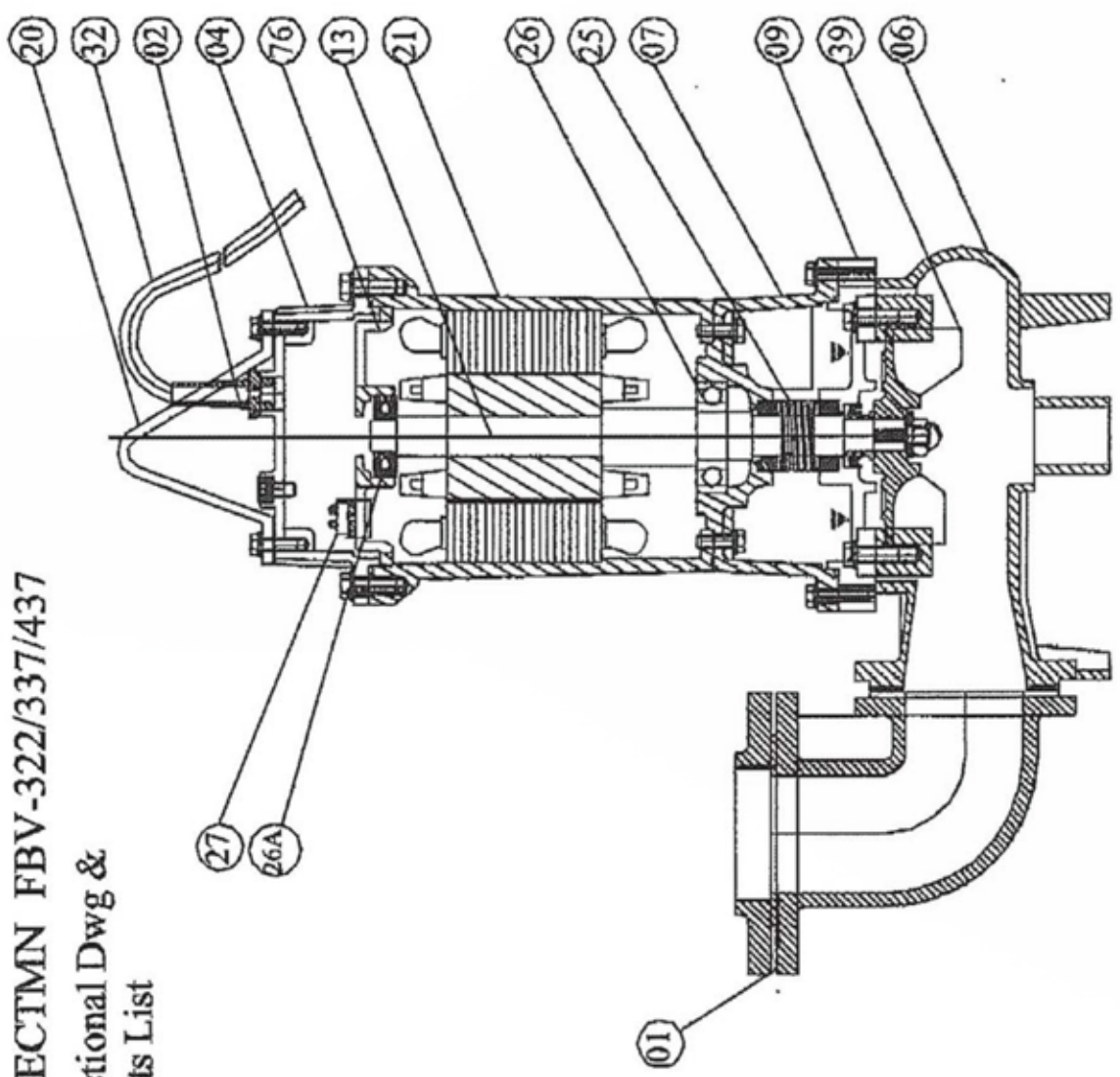

INSTALLATION

1. Before installation:

- a.) Use a megger to measure the insulation resistance between the ground wire and each phase of the motor.
Keep the ground wire off the ground during measurement. The value of each reading should be more than 20 meg-ohms.

2. Installation:

- a) Using a chain or lifting cable assembly, lower the pump into the tank or wet well.

DO NOT USE THE POWER & SENSOR CABLE TO LIFT PUMP

- b) Do not install the pump horizontally. Ensure that the pump is upright and on a secure base. Installation of pump with Quick Discharge Connector (QDC) shall be in accordance with manual entitled «Quick Discharge Connector.»
- c) Install pump in a location within the tank that has the least amount of turbulence.
- d) Support the discharge piping to prevent vibration.
- e) Install proper ventilation so that air will not become stagnant.
- f) Do not permit the end of the discharge piping to become submerged, as it will result in backflow when the pump stops.
- g) Set control operating levels (i.e. floats) so that pump is not running for more than ten minutes with water level at minimum operating level as indicated in below chart. Continuous operation of pump at minimum water level will result in automatic cut-off switch in motor to be activated.

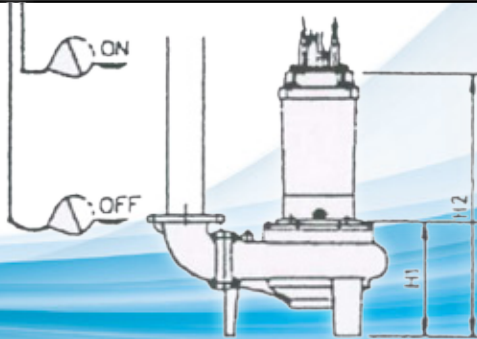

Motor Size (HP)	3	5	7.5	10	15	20	30
H2 (in)	21 ¹ / ₁₆	24 ¹ / ₁₆	27 ¹³ / ₁₆	27 ¹³ / ₁₆	30 ⁷ / ₈	30 ⁷ / ₈	32 ³ / ₈
H1 (in)	11	11	11 ⁹ / ₁₆	11 ⁹ / ₁₆	12 ¹ / ₁₆	12 ¹ / ₁₆	12 ¹⁵ / ₁₆

Figure 2

3. Electrical Wiring:

Note: All electrical wiring should be performed by a qualified electrician, and in accordance with all national and local electrical codes. Incorrect wiring can result in serious injury.

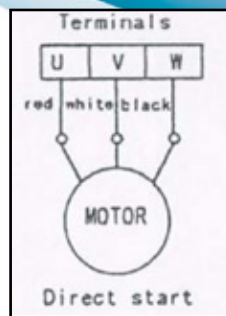

Figure 3

- a) Wiring should be performed as indicated in Figure 3.
- b) Do not allow the end of the cables to become immersed in water.
- c) Make sure pump is properly grounded using the green ground wire in the power cable. Do not connect the green wire to the power supply.

INSTALLATION

2. Installation (continued)

d.) Motor protection:

- For 3HP motors, a built-in auto-cut is used and will be activated when motor becomes overheated due to abnormal conditions such as locked rotor or single phasing. There is no external wiring for this feature.
- For 5HP to 30HP motors, a normally closed built-in thermal protector is used. When motor winding becomes over-heated, the circuit is opened, shutting the motor down and allowing it to cool. An external sensor cable is provided for this feature and must be connected to a thermal relay in the control panel. Failure to do so will void the warranty. Specifications for the thermal protector are listed below:

Contact rating: AC 230V, 13A (Max)

Contact type: Break contact (normally closed)

OPERATION

Operation

1. After completing installation, measure the insulation resistance again, using the procedure described in the «Installation» section.
2. Check to make sure there is an adequate amount of water in the wet well. Continuous operation of the pump in a dry condition will cause the motor protector to be activated.
3. Check the direction of rotation by turning on pump. If the discharge volume is low or unusual sounds are heard, it is likely that rotation has been reversed. If this happens, reverse two of the three power cable wires. (see Figure 4)

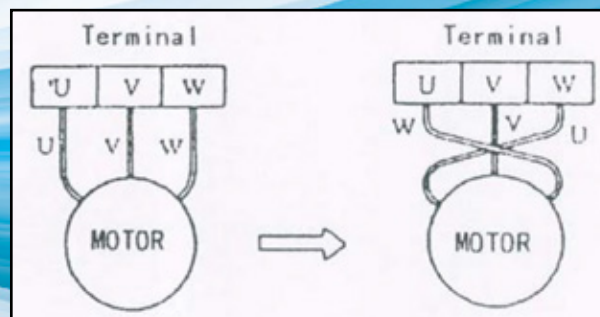

Figure 4

4. After confirming that the direction of rotation is correct, gradually open the discharge valve and allow the pump to run in continuous operation. Check the voltage, current and discharge pressure to make sure they are within allowable limits.
5. If voltage, current and discharge pressure are acceptable, you may continue to operate the pump on a continuous basis. Please refer to «Troubleshooting» section of the manual or contact your local EBARA distributor if one of these items is outside of allowable limits.
6. Do not allow the motor to start more than 20 times per hour.



MAINTENANCE

Note: Disassembly and repair of the pump should only be performed by factory trained service centers. Errors made by unqualified personnel can result in improper assembly and operation, therefore resulting in possible injury.



WARNING

Always turn the power OFF before inspecting and repair the pump. Failure to do so can result in serious injury.

1. Recommended daily inspections:
 - a) Check the motor current and its fluctuation. If there is a great deal of fluctuation, something may be clogging the pump.
 - b) Check to make sure the pump is providing the correct amount of flow. If the discharge decreases dramatically, something may be clogging the pump.
2. Recommended monthly inspections:
 - a) Measure the insulation resistance. The value should be more than 1 meg-ohm. If the resistance falls rapidly even with an initial reading of more than 1 meg-ohm, further inspection and possible repair may be required.
3. Recommended annual inspections:
 - a) Check the oil in the seal chamber. If the oil has turned white it is an indication that water has mixed with the oil and the mechanical seal needs to be replaced. The service life of the mechanical seal can be prolonged by replacing the oil in the seal chamber on an annual basis. See the recommended amount of oil below in Figure 5. Replace the oil by laying the pump on its side as illustrated in Figure 6.

Motor Size (HP)	3	5	7.5	10	15	20	30
Mechanical seal (mm)	30		40		45		
Lubricating oil (oz) Turbine oil ISO VG32	38		58		102		

Figure 5

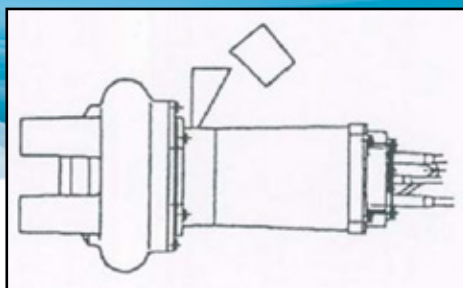

Figure 6

4. Extended storage:
 - a) Keep pump in a dry environment, out of direct sunlight.
 - b) Every 30 days, check the insulation resistance and rotate the impeller by hand to prevent rotating parts from seizing together.



TROUBLESHOOTING

Trouble	Cause	Remedy
Motor won't turn. Starts, but immediately stops.	<ol style="list-style-type: none"> (1) Foreign matter hinders level control float from functioning properly. (2) Power failure. (3) Large voltage unbalance. (4) Significant drop in voltage (5) There is an open phase (6) Faulty circuit connection (7) Blown fuse (8) Faulty starter (9) Defective float (10) Malfunctioning circuit breaker (11) Foreign matter clogging pump (12) Motor is shorted out (13) Motor bearings are frozen 	<ol style="list-style-type: none"> (1) Remove foreign matter (2 - 3) Contact electric power company for remedy (4) Check power supply (5) Check power supply; Inspect starter and connections (6) Correct wiring (7) Replace with correct size fuse (8) Replace with correct starter (9) Repair or replace float (10) Repair location of circuit (11) Remove clog from pump (12) Repair or replace (13) Repair or replace
Operates, but stops after a while. Thermal protector is activated.	<ol style="list-style-type: none"> (1) Prolonged dry operation has activated motor protector and caused pump to stop (2) High liquid temperature has activated motor protector and caused pump to stop 	<ol style="list-style-type: none"> (1) Raise the off float level (2) Lower liquid temperature
Does not pump. Inadequate volume.	<ol style="list-style-type: none"> (1) Reverse rotation (2) Valve is closed or partially clogged. (3) Significant drop in voltage (4) Discharge head is too high (5) Large piping loss (6) Low water level during operation causes vortexing (air suction) (7) Leak in discharge piping (8) Clog in discharge piping (9) Foreign matter clogging pump (10) Worn impeller 	<ol style="list-style-type: none"> (1) Correct rotation (2) Open valve (3) Check power supply (4) Recalculate and adjust (5) Recalculate and adjust (6) Raise water level or lower pump (7) Inspect, repair (8) Remove foreign matter (9) Remove foreign matter (10) Replace impeller
Overcurrent	<ol style="list-style-type: none"> (1) Large discrepancy between power source and voltage (2) Significant voltage drop (3) There is an open phase (4) Reverse rotation (5) Low head; pumping too much liquid (6) Foreign matter clogging pump (7) Motor bearing is worn or damaged 	<ol style="list-style-type: none"> (1) Contact power company for remedy (2) Contact power company for remedy (3) Check power supply Inspect starter & electrical connections (4) Check rotation (5) Adjust discharge valve to desired flow (6) Remove clog from the pump (7) Repair or replace
Pump vibrates; excessive noise during operation.	<ol style="list-style-type: none"> (1) Reverse rotation (2) Pump clogged with foreign matter (3) Piping vibrates 	<ol style="list-style-type: none"> (1) Correct rotation (2) Remove clog from pump (3) Install support for discharge piping

Submersible Wastewater Pumps

CMLU

Operating, Installation, and Maintenance

Sectional View

80CML62.2

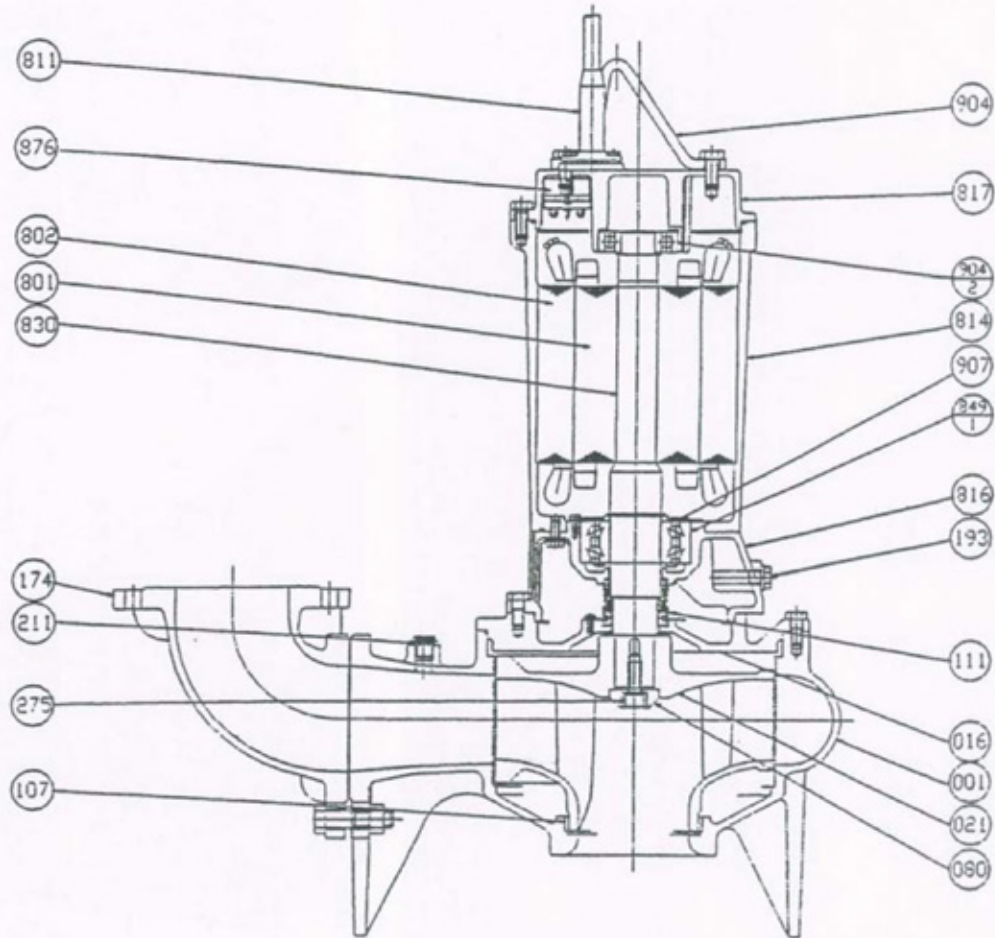

PART NO.	PART NAME	MATERIAL	NO. FOR 1 UNIT
001	CASING	CAST IRON	1
016	MECHANICAL SEAL COVER	CAST IRON	1
021	IMPELLER	CAST IRON	1
080	BUSHING	STAINLESS STEEL	1
107	WEAR RING	BRONZE	1
111	MECHANICAL SEAL	—	1
174	DISCHARGE PIPE	CAST IRON	1 SET
193	OIL PLUG	RUBBER (NBR)	1 SET
211	AIRVENT VALVE	BRASS	1
275	IMPELLER BOLT	STAINLESS STEEL	1
801	ROTOR	—	1
802	STATOR	—	1

PART NO.	PART NAME	MATERIAL	NO. FOR 1 UNIT
811	SUBMERSIBLE CABLE	—	2
814	MOTOR FRAME	CAST IRON	1
816	POWER SIDE BRACKET	CAST IRON	1
817	OPPOSITE SIDE BRACKET	CAST IRON	1
830	SHAFT	STAINLESS STEEL	1
849-1	BALL BEARING	—	1
849-2	BALL BEARING	—	1
876	AUTO CUT	—	3
904	LIFTING HANGER	STEEL	1
907	BEARING COVER	STEEL	1

Submersible Wastewater Pumps

CMLU

Operating, Installation, and Maintenance

Sectional View

5 to 10 HP
80CML
100CML
150CML

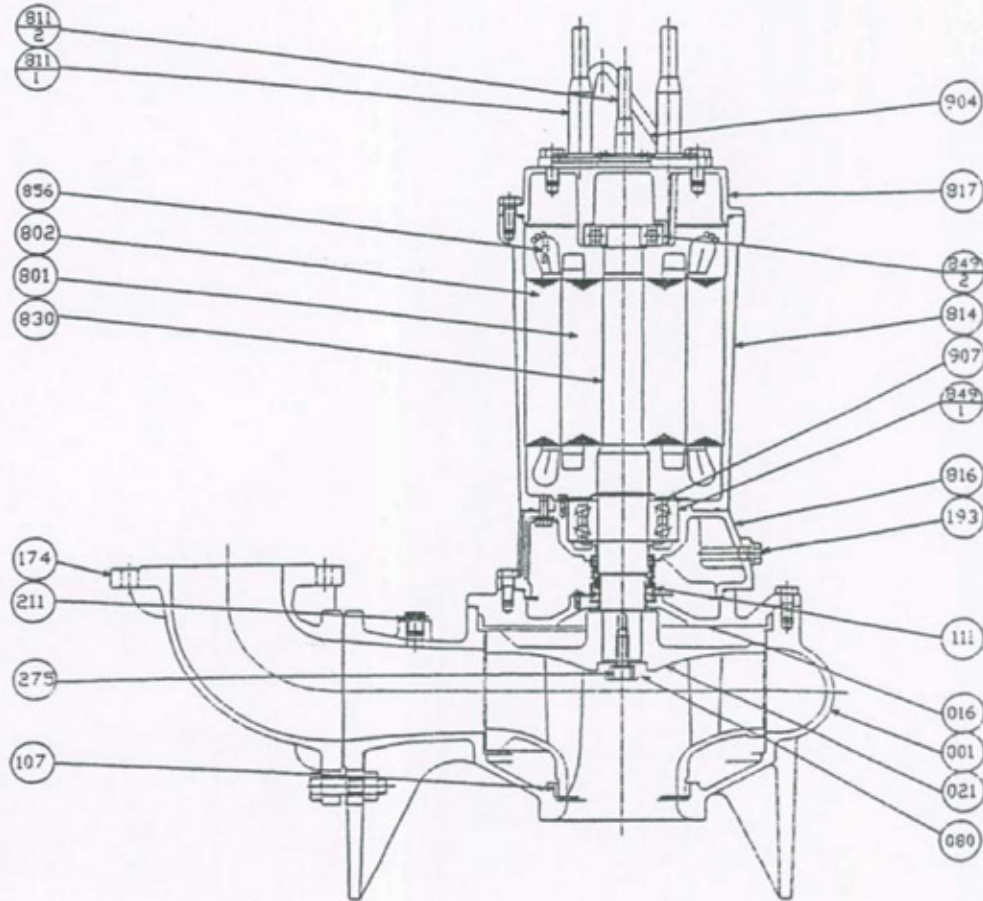

PART NO.	PART NAME	MATERIAL	NO. FOR 1 UNIT
001	CASING	CAST IRON	1
016	MECHANICAL SEAL COVER	CAST IRON	1
021	IMPELLER	CAST IRON	1
080	BUSHING	STEEL	1
107	WEARING RING	BRONZE	1
111	MECHANICAL SEAL	—	1
174	DISCHARGE PIPE	CAST IRON	1
193	OIL PLUG	RUBBER (NBR)	1 SET
211	AIRVENT VALVE	BRASS	1
275	IMPELLER BOLT	STAINLESS STEEL	1
801	ROTOR	—	1
802	STATOR	—	1

PART NO.	PART NAME	MATERIAL	NO. FOR 1 UNIT
811-1	SUBMERSIBLE CABLE (POWER)	—	2
811-2	SUBMERSIBLE CABLE (SIGNAL)	—	1
814	MOTOR FRAME	CAST IRON	1
816	POWER SIDE BRACKET	CAST IRON	1
817	OPPOSITE SIDE BRACKET	CAST IRON	1
830	SHAFT	STAINLESS STEEL	1
849-1	BALL BEARING	—	1
849-2	BALL BEARING	—	1
856	THERMAL PROTECTORT	—	3
904	LIFTING HANGER	STEEL	1
907	BEARING COVER	STEEL	1

Submersible Wastewater Pumps

CMLU

Operating, Installation, and Maintenance

Sectional View

15 to 30HP
80CML
100CML
150CML

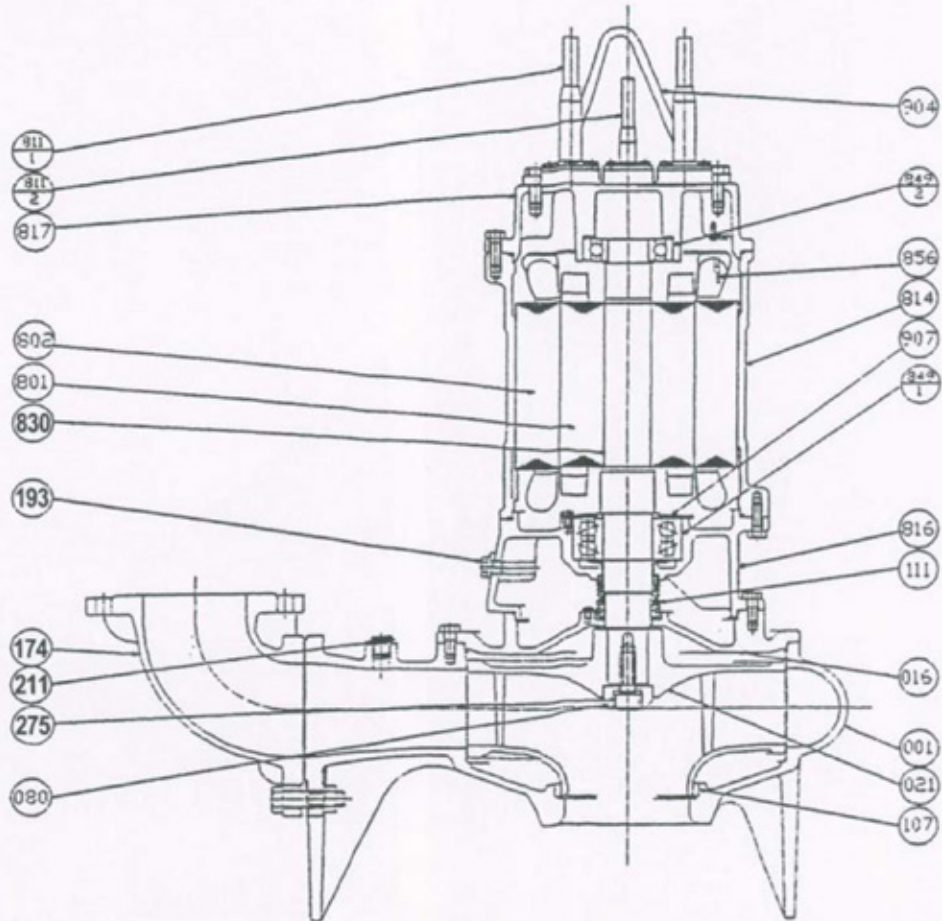

PART NO.	PART NAME	MATERIAL	NO. FOR 1 UNIT
001	CASING	CAST IRON	1
016	MECHANICAL SEAL COVER	CAST IRON	1
021	IMPELLER	CAST IRON	1
080	BUSHING	STEEL	1
107	WEARING RING	BRONZE	1
111	MECHANICAL SEAL	---	1
174	DISCHARGE PIPE	CAST IRON	1
193	OIL PLUG	RUBBER (NBR)	1 SET
211	AIRVENT VALVE	BRASS	1
275	IMPELLER BOLT	STAINLESS STEEL	1
801	ROTOR	---	1
802	STATOR	---	1

PART NO.	PART NAME	MATERIAL	NO. FOR 1 UNIT
811-1	SUBMERSIBLE CABLE (POWER)	---	2
811-2	SUBMERSIBLE CABLE (SIGNAL)	---	1
814	MOTOR FRAME	CAST IRON	1
816	POWER SIDE BRACKET	CAST IRON	1
817	OPPOSITE SIDE BRACKET	CAST IRON	1
830	SHAFT	STAINLESS STEEL	1
849-1	BALL BEARING	---	1
849-2	BALL BEARING	---	1
856	THERMAL PROTECTOR	---	3
904	LIFTING HANGER	STEEL	1
907	BEARING COVER	STEEL	1



1. Disassembly:

- a) Unscrew and remove the bolts (120-2), and lift the motor out of the pump casing. Lay it down on its side carefully.
- b) Unscrew and remove the impeller bolt (275), then pull the impeller (021) off the motor shaft.
- c) Unscrew and remove the oil plug (193) and drain oil from seal chamber.
- d) Unscrew and remove the bolts (120-1), and remove the mechanical seal cover (016) carefully. Take care as there may be oil remaining in the seal chamber.
- d) Remove the mechanical seal carefully to keep from damaging the seal faces.

2. Reassembly:

- a.) Perform the above instructions in reverse order, replacing the o-ring, seal washer and gasket.

Note 1: After reassembly to the point of installing impeller on the shaft, turn the impeller by hand to make sure that it rotates smoothly.

Note 2: It is recommended to use a screw adhesive (LOCTITE 271) on the impeller bolt (275) during reassembly.

Note 3: After installing casing back onto pump, turn the impeller by hand through the pump suction to make sure that it rotates smoothly without rubbing against the wear ring.

1A1 MODEL Cartridge Filter Housing



The 1A1 MODEL Cartridge Filter Housing is an all-metal, two-piece housing, featuring centerpost-type construction. The 1 A1 Model has a maximum operating temperature and pressure of 125 psig at 200°F. The 1A1 Model Cartridge Filter Housing has flow rates to up to 6 Gallons Per Minute (GPM).

APPLICABLE FILTER CARTRIDGES

Micro-Klean— III (Series U30)

Betapure—

DESIGN FEATURES

- All-metal, two-piece construction.
- Head and Sump Durable die-cast aluminum
- Mounting pads drilled to accept self-tapping screws provided with the optional mounting bracket.
- Centerpost-type design for easy cartridge changeout.

Options

- Mounting bracket; order separately.

STANDARD MODEL SPECIFICATIONS

Table 1 gives specifications for the 1A1 Model. Note that Maximum Operating Pressure is the rating for the housing only. Actual filter operating temperature depends on temperature capability of the filter cartridge used in the housing.

Operating Data	1A1 Model
Maximum Operating Pressure and Temperature	125 psi @ 200°F
Flow Rate (GPM)	See Table 2.
Materials of Construction	
Head and Sump	Die-Cast Aluminum
Centerpost	Stainless Steel
Head Gasket	Buna N & Cork
Cap-Nut Gasket	Fiber
Connection Sizes	3/8" NPTF
Cartridge Requirements	The model uses one filter cartridge. See "Cartridge Requirements" for more information.

TABLE 1 - SPECIFICATIONS

CARTRIDGE REQUIREMENTS

The 1A1 Model Cartridge Filter Housing uses one Micro-Klean III Cartridge or one Betapure Cartridge Filter.

FLOW RATES

Table 2 gives maximum flow rates in Gallons Per Minute (GPM) for the 1A1 Model Cartridge Filter Housings. Do not use Table 2 for filter sizing. Use the table as a guide only in establishing the housing flow rates. When you know the flow rate for a selected cartridge, then use the table to determine whether or not the housing is within the recommended flow rate. Remember to consider the amount of contaminant to be removed when selecting a filter.

Housing Model	Inlet / Outlet	FLOW (GPM)					
		Water	80 SSU	150 SSU	300 SSU	600 SSU	1000 SSU
1A1	3/8" NPTF	6	5	4.5	4	3.5	3

TABLE 2 - RECOMMENDED FLOW RATES

BENEFITS

- Long Service Life
- Quick and Easy Cartridge Change-out
- Reduced Down Time for Filter Change-out
- Reduced Labor Cost
- Uses Standard Filters
- Economical
- Easily Mounted to Wall or Support Structure



STANDARD MODEL DIMENSIONS

Table 3 gives dimensions in inches and shipping weight in pounds for the 1A1 Model Cartridge Filter Housing. These should be used for rough plumbing and approximate size definition. Note that figure 1 defines a length or width by a letter symbol in the top row. The square where the row and column meet is the selected dimension.

Model	A	B	C	D	Shipping Weight
1A1	6 3/16"	4 15/16"	3 1/2"	2 3/4"	3 lbs

TABLE 3. - 1A1 HOUSING DIMENSIONS

1A1 MODEL ORDERING GUIDE

Plant Code 01 Product Code 020

Model	Catalog Number	Mounting Bracket Kit*
1A1	44109-01	35581-05

* Order Separately

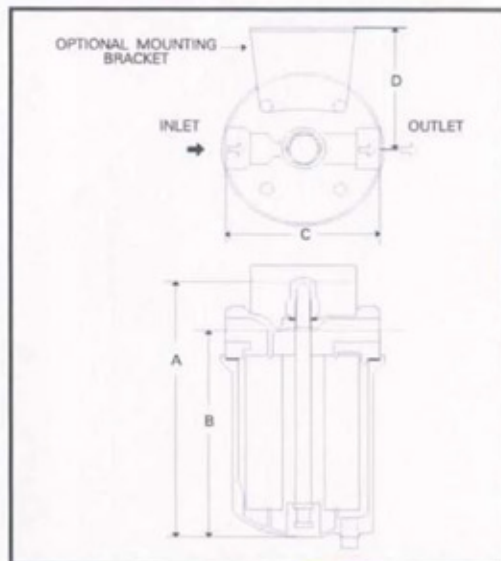
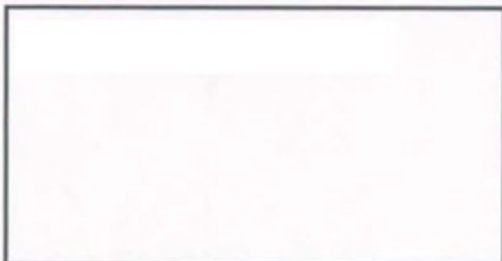

FIGURE 1. - 1A1 MODEL FILTER HOUSING

WARRANTY

Seller warrants its equipment against defects in workmanship and material for a period of 12 months from date of shipment from the factory under normal use and service and otherwise when such equipment is used in accordance with instructions furnished by Seller and for purposes disclosed in writing at the time of purchase, if any. Any unauthorized alteration or modification of the equipment by Buyer will void this warranty. Seller's liability under this warranty shall be limited to the replacement or repair, F.O.B., point of

manufacture, of any defective equipment or part which, having been returned to the factory, transportation charges prepaid, has been inspected and determined by Seller to be defective. THIS WARRANTY IS IN LIEU OF ANY OTHER WARRANTY, EITHER EXPRESSED OR IMPLIED, AS TO DESCRIPTION, QUALITY, MERCHANTABILITY, FITNESS FOR ANY PARTICULAR PURPOSE OR USE, OR ANY OTHER MATTER. Under no circumstances shall Seller be liable to Buyer or any third party for any loss of profits or



Nous sommes fier fournisseur des projets suivants, soient terminés ou en cours de projets :



**250 N 10th
Avenue North**
250 N 10th St, Brooklyn,
NY, USA



Allegria Hotel
80 W Broadway,
Long Beach, NY, USA



EvoloS Tower
101 Rue de la Rotonde,
Verdun, QC, CA



Bogle Vineyards
37783 Co Rd 144,
Clarksburg, CA

Ventes & Service:

Québec, Canada
Tél. : (450) 621-2995
Fax : (450) 621-4995

Lake Worth
Florida, USA
33467-5749

Toronto, Canada
Tel. : +1 (647) 544-2995

www.flofab.com

SERVICE 24/7 : parts@flofab.com

