

FLENDER COUPLINGS
CATALOG **FLE 10.1**
EDITION 2023.2 EN



TORSIONALLY RIGID COUPLINGS
ZAPEX, N-ARPEX AND ARPEX

TORSIONALLY RIGID COUPLINGS



Catalog FLE 10.1 Edition 2023.2 EN

Introduction

Torsionally Rigid Gear Couplings

ZAPEX ZW

ZAPEX ZN

Torsionally Rigid All-Steel Couplings

N-ARPEX, ARPEX

Flexible Couplings

N-EUPEX

RUPEX

N-BIPEX

Highly Flexible Couplings

ELPEX-B

ELPEX-S

ELPEX

Fluid Couplings

FLUDEX

Backlash-free Couplings

SIPEX

BIPEX-S

Appendix

E

4

5

6

7

8

9

10

11

12

13

14

15

A

FLE 10 CATALOG GROUP



Product catalog FLE 10.1
FLEX-C10001-00-7600
Torsionally Rigid Couplings



Product catalog FLE 10.3
FLEX-C10003-00-7600
Highly Flexible Couplings



Product catalog FLE 10.2
FLEX-C10001-00-7600
Flexible Couplings



Product catalog FLE 10.4
FLEX-C10004-00-7600
Fluid Couplings

For further coupling catalogs, see page A/6

FLENDER COUPLINGS
CATALOG **FLE 10.5**
EDITION EN



HIGH PERFORMANCE COUPLINGS
ARPEX

flender.com

FLENDER

Product catalog FLE 10.5
FLEX-C10120-00-7600
High Performance Couplings

FLENDER-COUPLINGS
CATALOG **FLE 10.7**
EDITION EN



SAFETY COUPLINGS
ARPEX

flender.com

FLENDER

Product catalog FLE 10.7
FLEX-C10122-00-7600
Safety couplings

FLENDER COUPLINGS
CATALOG **FLE 10.6**
EDITION EN

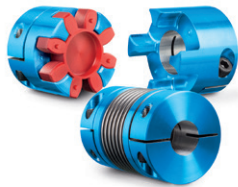

BACKLASH-FREE COUPLINGS
SIPEX AND BIPEX-S

flender.com

FLENDER

Product catalog FLE 10.6
FLEX-C10121-00-7600
Backlash-free couplings

FLENDER CLAMPING ELEMENTS
CATALOG **FLE 10.8**
EDITION EN



CLAMPING ELEMENTS
FASTEX

flender.com

FLENDER

Product catalog FLE 10.8
FLEX-C10152-7600
Clamping elements

INTRODUCTION

E

The mechanical drive train comprises individual units such as motor, gear unit and driven machine. The coupling connects these component assemblies.

As well as the transmission of rotary motion and torque, other requirements may be made of the coupling.

- Compensation for shaft misalignment with low restorative forces
- Control of characteristic angular vibration frequency and damping
- Interruption or limitation of torque
- Noise insulation, electrical insulation

Couplings are frequently chosen after the machines to be connected have already been selected. Thanks to a large number of different coupling assembly options, specified marginal conditions for clearance and connection geometry can be met from the standard range. The coupling also performs secondary functions, e.g. providing a brake disk or brake drum for operating or blocking brakes, devices to record speed or the attachment of sprockets or pulleys.

Couplings are divided into two main groups, couplings and clutches.

Clutches interrupt or limited the transmissible torque. The engaging and disengaging forces on externally operated clutches are introduced via a mechanically, electrically, hydraulically or pneumatically operating mechanism. Overload, centrifugal or freewheel clutches draw their engaging energy from the transmitted output.

Rigid couplings, designed as clamp, flanged or mechanism couplings, connect machines which must not undergo any shaft misalignment. Hydrodynamic couplings, often also called fluid or Föttinger couplings, are used as starting couplings in drives with high mass moments of inertia of the driven machine. In drive technology very often flexible, positive couplings, which may be designed to be torsionally rigid, torsionally flexible or highly flexible, are used.

Torsionally rigid couplings are designed to be rigid in a peripheral direction and flexible in radial and axial directions. The angle of rotation and torque are conducted through the coupling without a phase shift.

Torsionally flexible couplings have resilient elements usually manufactured from elastomer materials. Using an elastomer material with a suitable ShoreA hardness provides the most advantageous torsional stiffness and damping for the application. Shaft misalignment causes the resilient elements to deform.

Highly flexible couplings have large-volume (elastomer) resilient elements of low stiffness. The angle of rotation and torque are conducted through the coupling with a considerable phase shift.

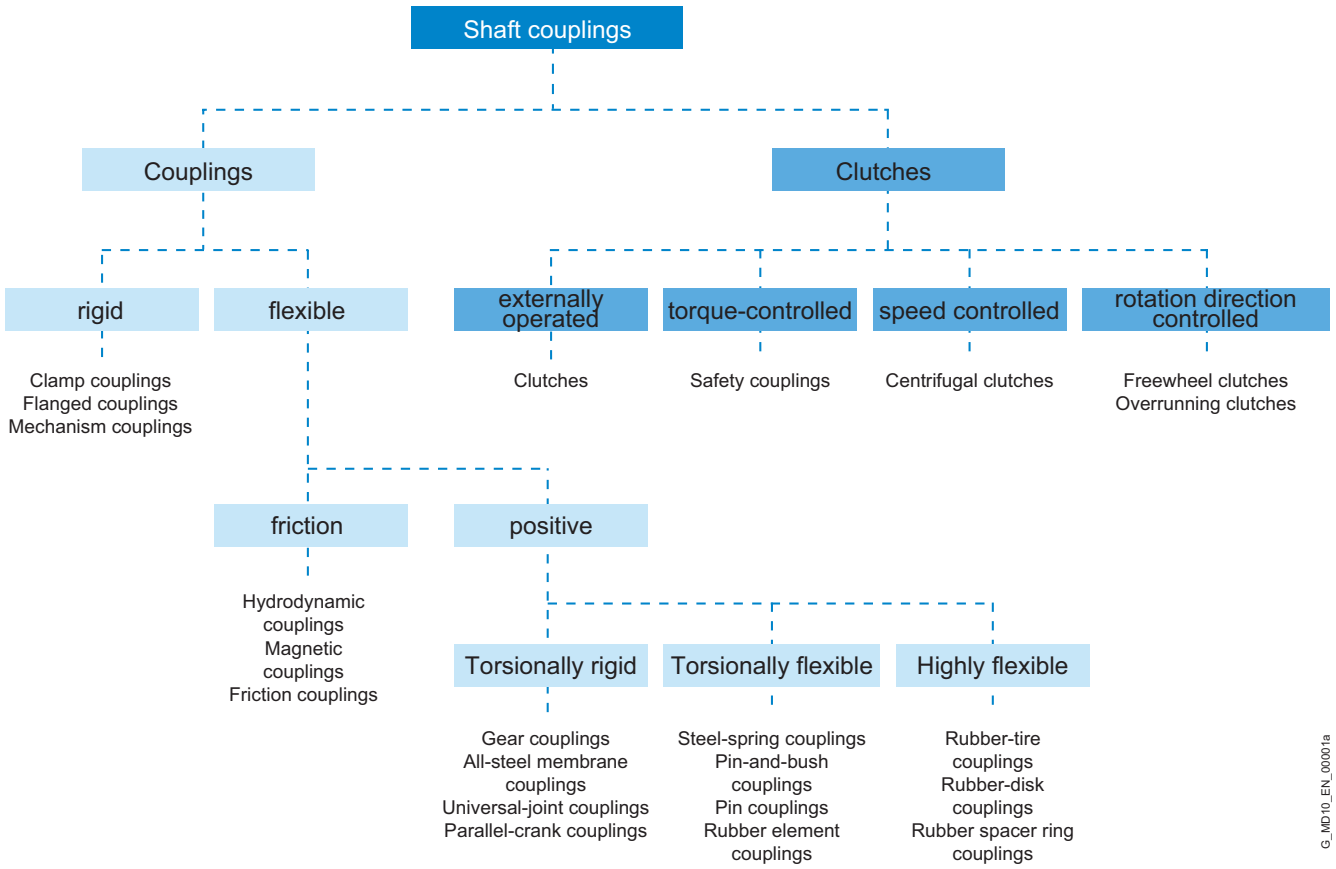

G_MD10_EN_00001a

OUR COUPLING GROUPS AT A GLANCE

E

N-EUPEX, RUPEX and N-BIPEX

Flexible Couplings

Flexible Flender couplings have a wide range of possible applications. A broad standard modular system as well as specially designed application-specific couplings are available.

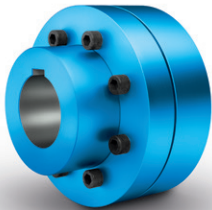

N-EUPEX
cam couplings
Rated torque:
12 Nm ... 93,500 Nm

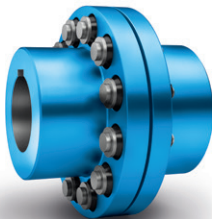

RUPEX
pin-and-bush couplings
Rated torque:
120 Nm ... 1,690,000 Nm



N-BIPEX
cam couplings
Rated torque:
12 Nm ... 4,650 Nm

ELPEX, ELPEX-B and ELPEX-S

Highly Flexible Couplings

ELPEX® couplings are free of circumferential back-lash. Their damping capacity and low torsional stiff-ness make them especially well-suited for coupling machines with strongly non-uniform torque characteristics or large shaft misalignment.



ELPEX
elastic ring couplings
Rated torque:
1,600 Nm ... 90,000 Nm



ELPEX-B
elastic tire couplings
Rated torque:
57 Nm ... 19,000 Nm



ELPEX-S
rubber disk couplings
Rated torque:
200 Nm ... 63,000 Nm

ZAPEX gear couplings and ARPEX all-steel couplings

Torsionally rigid couplings

For transmission of high torques, we offer both ARPEX all-steel couplings and ZAPEX gear couplings in a range of versions. Their purposes of application vary according to specific requirements with respect to shaft misalignment, temperature and torque.

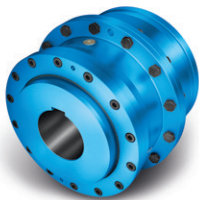

ZAPEX
gear couplings
Rated torque:
1,020 Nm ... 7,200,000 Nm

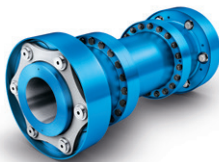

ARPEX
high Performance Couplings
Rated torque:
1,100 Nm ... 936,000 Nm



N-ARPEX and ARPEX
all-steel couplings
Rated torque:
92 Nm ... 2,000,000 Nm

BIPEX-S and SIPEX

Backlash-free couplings

The vibration-damping, electrically insulating plug-in BIPEX-S elastomer couplings and SIPEX metal bellows couplings with very high torsional stiffness deliver especially isogonal torque transmission.

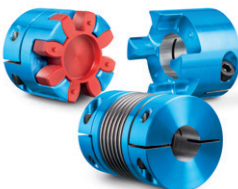

BIPEX-S and SIPEX
Rated torque:
0.1 Nm ... 5,000 Nm

FLUDEX

Hydrodynamic couplings

The FLUDEX hydrodynamic fluid coupling works according to the Föttinger principle. It functions entirely free of wear.



FLUDEX
fluid Couplings
Power:
1.2 kW ... 2,500 kW

Application-specific couplings

Couplings for rail vehicles must meet high demands. Due to their high degree of standardization and wide variety, they can be used in the most diverse vehicle types.

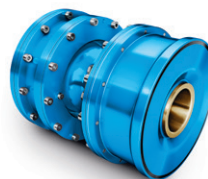

Railway coupling
Rated torque:
1,000 Nm ... 9,500 Nm

Each wind turbine coupling is designed to optimally meet the requirements of the respective wind turbine. The coupling connects the fast-running gear shaft with the generator shaft and is available for wind turbines with a capacity of up to 12 MW.

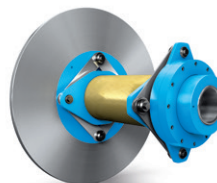

Wind turbine couplings
Rated torque:
10,000 Nm ... 60,000 Nm

TECHNICAL INFORMATION AND COUPLING SELECTION

E

Technical Information	E/10
Shaft misalignment	E/10
Balancing	E/11
Shaft-hub connections	E/13
Standards	E/14
Key to symbols	E/15
<hr/>	
Selection of the coupling series	E/16
Typical coupling solutions for different example applications	E/17
<hr/>	
Selection of the coupling size	E/18
Coupling load in continuous operation	E/18
Coupling load at maximum and overload conditions	E/19
Coupling load due to dynamic torque load	E/19
Checking the maximum speed	E/20
Checking permitted shaft misalignment	E/20
Checking bore diameter, mounting geometry and coupling design	E/20
Coupling behavior under overload conditions	E/20
Checking shaft-hub connection	E/20
Checking low temperature and chemically aggressive environment	E/20
<hr/>	
Features of the standard type	E/21
<hr/>	

TECHNICAL INFORMATION

E

Shaft misalignment

Shaft misalignment is the result of displacement during assembly and operation and, where machines constructed with two radial bearings each are rigidly coupled, will cause high loads being placed on the bearings. Elastic deformation of base frame, foundation and machine housing will lead to shaft misalignment which cannot be prevented, even by precise alignment.

Furthermore, because individual components of the drive train heat up differently during operation, heat expansion of the machine housings causes shaft misalignment. Poorly aligned drives are often the cause of seal, rolling bearing or coupling failure. Alignment should be carried out by specialist personnel in accordance with operating instructions.

Depending on the direction of the effective shaft misalignment a distinction is made between:

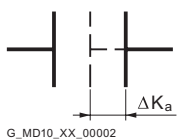

Axial misalignment

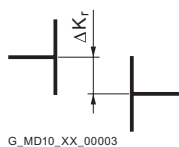

Radial misalignment

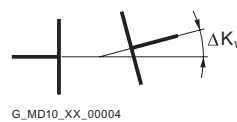

Angular misalignment

Couplings can be categorized into one of the following groups:

Single-joint couplings

Couplings with flexible elements mainly made of elastomer materials. Shaft misalignment results in deformation of the elastomer elements. The elastomer elements can absorb shaft misalignment as deformations in an axial, radial and angular direction. The degree of permissible misalignment depends on the coupling size, the speed and the type of elastomer element.

Single-joint couplings do not require an adapter and are therefore short versions.

Example:

In the case of a RUPLEX RWN 198 coupling with an outer diameter of 198 mm and a speed of 1500 rpm, the permitted radial misalignment is $\Delta K_r = 0.3$ mm.

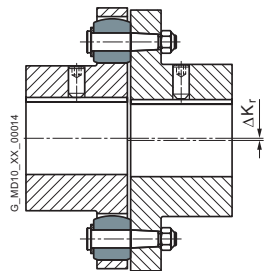

Two-joint couplings

Two-joint couplings are always designed with an adapter. The two joint levels are able to absorb axial and angular misalignment. Radial misalignment occurs via the gap between the two joint levels and the angular displacement of the joint levels. The permitted angular misalignment per joint level is frequently about 0.5°. The permitted shaft misalignment of the coupling can be adjusted via the length of the adapter. If there are more than two joint levels, it is not possible to define the position of the coupling parts relative to the axis of rotation. (The less frequently used parallel-crank couplings are an exception).

Example:

N-ARPEX ARN-6 NEN 217-6 with a shaft distance of 140 mm with a permitted radial misalignment of $\Delta K_r = 2.2$ mm [angle per joint level 1.0°].

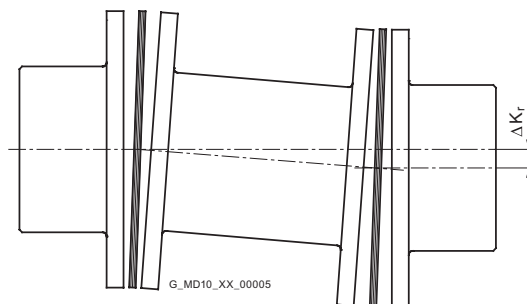

Balancing

Balance quality levels

The so-called quality level G to DIN ISO 21940 indicates a range of permitted residual imbalance from zero up to an upper limit. Applications can be grouped on the basis of similarity analysis. For many applications a coupling balance quality of G 16 is sufficient. On drives susceptible to vibration the balance quality should be G 6.3. Only in special cases is a better balance quality required.

Balancing standard in accordance with DIN ISO 21940-32

Besides the required balance quality, it is necessary to set standards which define how the mass of the parallel key is to be taken into consideration when balancing. In the past, motor rotors have frequently been balanced in accordance with the full parallel key standard. The "appropriate" balance condition of the coupling hub was described as "balancing with open keyway" or "balancing after keyseating". Today it is usual for the motor rotor, as well as the gear unit and driven machine shaft, to be balanced in accordance with the half parallel key standard.

Full parallel key standard

The parallel key is inserted in the shaft keyway, then balancing is carried out. The coupling hub must be balanced without parallel key after keyseating.

Marking of shaft and hub with "F" (for "full").

Half parallel key standard

The balancing standard normally applied today. Before balancing, a half parallel key is inserted in the shaft and another in the coupling hub. Alternatively, balancing can be carried out before cutting the keyway.

The balanced parts must be marked with an "H". This marking can be dispensed with if it is absolutely clear which parallel key standard has been applied.

No parallel key standard

Balancing of shaft and coupling hub after keyseating, but without parallel key. Not used in practice. Marking of shaft and hub with "N" (for "no").
The length of the parallel key is determined by the shaft keyway. Coupling hubs may be designed considerably shorter than the shaft.

To prevent imbalance forces caused by projecting parallel key factors when balancing in accordance with the half parallel key standard in the case of applications with high balancing quality requirements, grooved spacer rings can be fitted or stepped parallel keys used.

Flender Balancing Standard

The balancing quality level, together with the operating speed, results in the maximum permissible eccentricity of the center of gravity of the coupling or the coupling subassembly. In the Flender article number the balancing quality can be preset with the help of the order code. Additionally, also the balance quality level to DIN ISO 21940 can be preset together with the operating speed belonging to it, which then be taken as priority.

$$e_{perm} = 9550 \cdot \frac{G}{n}$$

$$e_{coupl} \leq e_{perm}$$

Permitted eccentricity of center of gravity e_{perm} in μm
 Eccentricity of center of gravity of coupling e_{coupl} in μm
 Balancing quality level G in mm/s
 Coupling speed n in rpm

Eccentricity of center of gravity of coupling e_{coupl}	Flender balancing quality	Order code
maximum 100 μm	standard balancing	without specification
maximum 40 μm	fine balancing	W02
maximum 16 μm	micro-balancing	W03
better than 16 μm	special balancing	on request

TECHNICAL INFORMATION

E

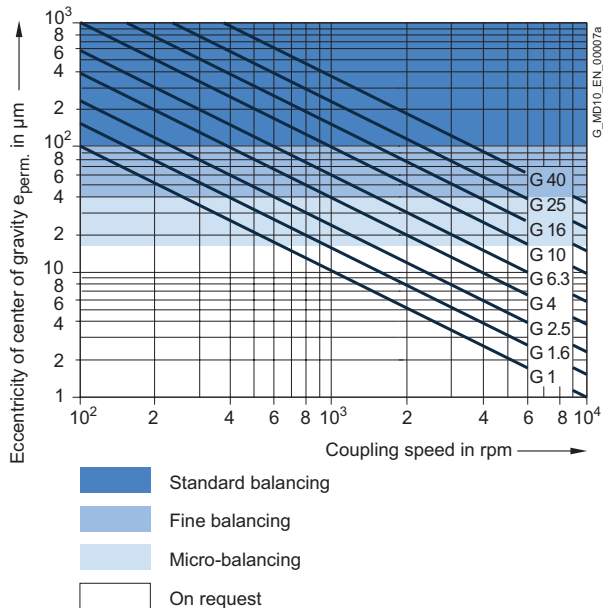

Example:
Coupling speed = 1450 rpm
required balancing quality level G 6.3

$$e_{perm} = 9550 \cdot \frac{G}{n} = 9550 \cdot \frac{6.3}{1450} \mu\text{m}$$

Thus, the required eccentricity of center of gravity is 41.5 µm. The fine balancing with a maximum eccentricity of center of gravity of 40 mm fulfills this requirement; therefore, the order code W02 has to be specified when ordering.

For many applications the following balancing quality recommendation applies:

Coupling	standard balancing $v = DA \cdot n/19100$	fine balancing
short version with $LG \leq 3 \times DA$	$v < 30 \text{ m/s}$	$v > 30 \text{ m/s}$
long version with $LG > 3 \times DA$	$v \leq 15 \text{ m/s}$	$v > 15 \text{ m/s}$

Peripheral speed	v	in mm/s
Coupling outer diameter	DA	in mm
Coupling speed	n	in rpm
Coupling length	LG	in mm

The following standards on balancing must be observed:

- couplings are balanced in subassemblies.
- hub parts without finished bore are unbalanced.
- the number of balancing levels (one- or two-level balancing) is specified by Flender.
- without special specification balancing is done in accordance with the half-parallel-key standard. Balancing in accordance with the full-parallel-key standard must be specified in the order number.
- For FLUDEX couplings special balancing standards specified in Section 13 apply.
- ARPEX couplings in standard balancing quality are unbalanced. Thanks to steel components machined all over and precisely guided adapters the balancing quality of standard balancing is nearly always adhered to.

Shaft-hub connections

The bore and the shaft-hub connection of the coupling are determined by the design of the machine shaft. In the case of IEC standard motors, the shaft diameters and parallel key connections are specified in accordance with DIN EN 50347. For diesel motors, the flywheel connections are frequently specified in accordance with SAE J620d or DIN 6288. Besides the very widely used connection of shaft and hub with parallel keys to DIN 6885 and cylindrically bored hubs, couplings with Taper clamping bushes, clamping sets, shrink-fit connections and splines to DIN 5480 are common.

The form stability of the shaft/hub connection can only be demonstrated when shaft dimensions and details of the connection are available. The coupling torques specified in the tables of power ratings of the coupling series do not apply to the shaft-hub connection unrestrictedly.

In the case of the shaft-hub connection with parallel key, the coupling hub must be axially secured, e.g. with a set screw or end washer. The parallel key must be secured against axial displacement in the machine shaft.

All Flender couplings with a finished bore and parallel keyway are designed with a set screw. Exceptions are some couplings of the FLUDEX series, in which end washers are used. During assembly, Taper clamping bushes are frictionally connected to the machine shaft.

TECHNICAL INFORMATION

E

Standards

Machines

2006/42/EG	EC Machinery Directive
2014/34/EU	ATEX Directive – Manufacturer
1999/92/EG	ATEX Directive – Operator – and ATEX Guideline to Directive 1999/92/EC
DIN EN 80079-36	Non-electrical equipment for use in potentially explosive atmospheres
DIN EN 1127	Explosive atmospheres, explosion prevention and protection
DIN EN 50347	General-purpose three-phase induction motors having standard dimensions and outputs

Couplings

DIN 740	Flexible shaft couplings Part 1 and Part 2
VDI Guideline 2240	Shaft couplings - Systematic subdivision according to their properties VDI Technical Group Engineering Design 1971
API 610	Centrifugal Pumps for Petroleum, Chemical and Gas Industry Services
API 671	Special Purpose Couplings for Petroleum, Chemical and Gas Industry Services
ISO 10441	Petroleum, petrochemical and natural gas industries – Flexible couplings for mechanical power transmission-special-purpose applications
ISO 13709	Centrifugal pumps for petroleum, petrochemical and natural gas industries

Balancing

DIN ISO 21940	Requirements for the balancing quality of rigid rotors
DIN ISO 21940-32	Mechanical vibrations; standard governing the type of parallel key during balancing of shafts and composite parts

Shaft-hub connections

DIN 6885	Driver connections without taper action – parallel keys – keyways
SAE J620d	Flywheels for industrial engines ...
DIN 6288	Reciprocating internal combustion engines Dimensions and requirements for flywheels and flexible couplings
ASME B17.1	Keys and keyseats
DIN EN 50347	General-purpose three-phase induction motors with standard dimensions and output data
BS 46-1:1958	Keys and keyways and taper pins Specification

Key to symbols

Name	Symbols	Unit	Explanation
Torsional stiffness, dynamic	C_{Tdyn}	Nm/rad	For calculating torsional vibration
Excitation frequency	f_{err}	Hz	Excitation frequency of motor or driven machine
Moment of inertia	J	kgm ²	Moment of inertia of coupling sides 1 and 2
Axial misalignment	ΔK_a	mm	Axial misalignment of the coupling halves
Radial misalignment	ΔK_r	mm	Radial misalignment of the coupling halves
Angular misalignment	ΔK_w	°	Angular misalignment of the coupling halves
Service factor	FB		Factor expressing the real coupling load as a ratio of the nominal coupling load
Frequency factor	FF		Factor expressing the frequency dependence of the fatigue torque load
Temperature factor	FT		Factor taking into account the reduction in strength of flexible rubber materials at a higher temperature
Weight	m	kg	Weight of the coupling
Rated speed	n_N	rpm	Coupling speed
Maximum coupling speed	n_{Kmax}	rpm	Maximum permissible coupling speed
Rated power	P_N	kW	Rated output on the coupling, usually the output of the driven machine
Rated torque	T_N	Nm	Rated torque as nominal load on the coupling
Fatigue torque	T_W	Nm	Amplitude of the dynamic coupling load
Maximum torque	T_{max}	Nm	More frequently occurring maximum load, e.g. during starting
Overload torque	T_{OL}	Nm	Very infrequently occurring maximum load, e.g. during short circuit or blocking conditions
Rated coupling torque	T_{KN}	Nm	Torque which can be transmitted as static torque by the coupling over the period of use.
Maximum coupling torque	T_{Kmax}	Nm	Torque which can be frequently transmitted (up to 25 times an hour) as maximum torque by the coupling.
Coupling overload torque	T_{KOL}	Nm	Torque which can very infrequently be transmitted as maximum torque by the coupling.
Fatigue coupling torque	T_{KW}	Nm	Torque amplitude which can be transmitted by the coupling as dynamic torque at a frequency of 10 Hz over the period of use.
Resonance factor	V_R		Factor specifying the torque increase at resonance
Temperature	T_a	°C	Ambient temperature of the coupling in operation
Damping coefficient	Ψ	psi	Damping parameter

SELECTION OF THE COUPLING SERIES

E

The coupling series is frequently determined by the driven machine and the design of the drive train. Common selection criteria are listed below and assigned to coupling properties, which are used to select the coupling series. Additionally, the price of the coupling and availability are important criteria for determining the coupling series to be used.

The **FLUDEX series** operates positively and transmits the torque with the aid of a flowing oil or water filling.

FLUDEX couplings are used to reduce starting and/or overload torques. During starting, the motor may, for example, run up within a very short time; because of the FLUDEX coupling, the drive train with the driven machine may accelerate after a delay and without increased torque load.

The FLUDEX coupling cannot compensate for shaft misalignment and is therefore designed in combination with a displacement coupling, a cardan shaft or a belt drive. The displacement coupling may be selected in accordance with the criteria described below.

Selection criteria						
	Torque range	Speed range	Torsional stiffness		Highly flexible	Operating temperature range
	Rated coupling torque T_{KN}	Peripheral speed $v_{max} = DA \cdot n_{max}/19100$	torsionally rigid	torsionally flexible		
ZAPEX	1020 ... 7200000 Nm	60 m/s	■	-	-	-20 ... +80 °C
N-ARPEX	350 ... 2000000 Nm	110 m/s	■	-	-	-50 ... +280 °C
N-EUPEX	12 ... 93500 Nm	36 m/s	-	■	-	-50 ... +100 °C
N-EUPEX DS	19 ... 21200 Nm	36 m/s	-	■	-	-30 ... +80 °C
RUPEX	120 ... 1690000 Nm	60 m/s	-	■	-	-50 ... +100 °C
N-BIPEX	12 ... 4650 Nm	45 m/s	-	■	-	-50 ... +120 °C
ELPEX-B	57 ... 19000 Nm	45 m/s	-	-	■	-50 ... +70 °C
ELPEX-S	200 ... 63000 Nm	66 m/s	-	-	■	-40 ... +120 °C
ELPEX	1600 ... 90000 Nm	60 m/s	-	-	■	-40 ... +80 °C

Typical coupling solutions for different example applications

The specified application factors are recommendations; regulations, rules and practical experience take priority as assessment criteria.

No application factor need be taken into account with FLUDEX couplings.

In the case of highly flexible couplings of the ELPEX, ELPEX-S and ELPEX-B series, deviating application factors are stated in the product descriptions. FLUDEX couplings are mostly mounted on the high-speed gear shaft.

Example applications	Application factor FB
Electric motor without gear unit	
Centrifugal pumps	1.0
Piston pumps	1.5
Vacuum pumps	1.5
Fans with T_N less than 75 Nm	1.5
Fans with T_N from 75 to 750 Nm	1.75
Fans with T_N larger than 750 Nm	1.75
Blowers	1.5
Frequency converters / generators	1.25
Reciprocating compressors	1.75
Screw-type compressors	1.5
Internal-combustion engine without gear unit	
Generators	1.75
Pumps	1.5
Fans	1.75
Hydraulic pumps, excavators, construction machines	1.5
Compressors / screw-type compressors	1.5
Agricultural machinery	1.75
Other	
Turbine gear units	1.5
Hydraulic motor - gear unit	1.25
Electric motor with gear unit	
Chemical industry	
Extruders	1.5
Pumps - centrifugal pumps	1.0
Pumps - piston pumps	1.75
Pumps - plunger pumps	1.5
Reciprocating compressors	1.75
Calenders	1.5
Kneaders	1.75
Cooling drums	1.25
Mixers	1.25
Stirrers	1.25
Toasters	1.25
Drying drums	1.25
Centrifuges	1.25
Crushers	1.5
Power generation and conversion	
Compressed air, reciprocating compressors	1.75

Example applications	Application factor FB
Compressed air, screw-type compressors	1.25
Air - Blowers	1.5
Air - Cooling tower fans	1.5
Air - Turbine blowers	1.5
Generators, converters	1.25
Welding generators	1.25
Metal production, iron and steel works	
Plate tilters	1.5
Ingot pushers	1.75
Slabbing mill	1.75
Coiling machines	1.5
Roller straightening machines	1.5
Roller tables	1.75
Shears	1.75
Rollers	1.75
Metal working machines	
Plate bending machines	1.5
Plate straightening machines	1.5
Hammers	1.75
Planing machines	1.75
Presses, forging presses	1.75
Shears	1.5
Grinding machines	1.25
Punches	1.5
Machine tools: Main drives	1.5
Machine tools: Auxiliary drives	1.25
Food industry	
Filling machines	1.25
Kneading machines	1.5
Mashers	1.5
Sugar cane production	1.5
Production machines	
Construction machines, hydraulic pumps	1.25
Construction machines, traversing gears	1.5
Construction machines, suction pumps	1.5
Construction machines, concrete mixers	1.5
Printing machines	1.25
Woodworking - barking drums	1.5
Woodworking - planing machines	1.5

Example applications	Application factor FB
Woodworking - reciprocating saws	1.5
Grinding machines	1.5
Textile machines - winders	1.5
Textile machines - printing machines	1.5
Textile machines - tanning vats	1.5
Textile machines - shredders	1.5
Textile machines - looms	1.5
Packaging machines	1.5
Brick molding machines	1.75
Transport and logistics	
Passenger transport - elevators	1.5
Passenger transport - escalators	1.5
Conveyor systems - bucket elevators	1.5
Conveyor systems - hauling winches	1.5
Conveyor systems - belt conveyors	1.5
Conveyor systems - endless-chain conveyors	1.5
Conveyor systems - circular conveyors	1.5
Conveyor systems - screw conveyors	1.5
Conveyor systems - inclined hoists	1.5
Crane traversing gear	1.5
Hoisting gear	1.5
Crane lifting gear	2.0
Crane traveling gear	1.5
Crane slewing gear	1.5
Crane fly jib hoists	1.5
Cable railways	1.5
Drag lifts	1.5
Winches	1.5
Cellulose and paper	
Paper-making machines, all	1.5
Pulper drives	1.5
Cement industry	
Crushers	1.75
Rotary furnaces	1.5
Hammer mills	1.75
Ball mills	1.75
Pug mills	1.75
Mixers	1.5
Pipe mills	1.5
Beater mills	1.75
Separators	1.5
Roller presses	1.75

SELECTION OF THE COUPLING SIZE

E

The torque load of the coupling must be determined from the output of the driven machine and the coupling speed.

Rated coupling load $T_N = 9550 \times P_N / n_N$
 (T_N in Nm; P_N in kW; n_N in rpm)

The rated coupling load obtained in this way must be multiplied by factors and compared with the rated coupling torque. An ideal but expensive method is to measure the torque characteristic on the coupling. For this, Flender offers special adapters fitted with torque measuring devices.

The rated coupling torque T_{KN} is the torque which can be transmitted by the coupling over an appropriate period of use if the load is applied to the coupling purely statically at room temperature.

Application factors are to express the deviation of the real coupling load from the "ideal" load condition.

Coupling load in continuous operation

The operating principles of the driving and driven machines are divided into categories and the application factor FB derived from these in accordance with DIN 3990-1.

Application factor for N-EUPEX, N-EUPEX-DS, RUPEX, N-BIPEX, ELPEX-B, N-ARPEX, ARPEX, ZAPEX and FLUDEX

Torque characteristic of the driving machine	Torque characteristic of the driven machine			
	uniform	uniform with moderate shock loads	non uniform	very rough
uniform	1.0	1.25	1.5	1.75
uniform with moderate shock loads	1.25	1.5	1.75	2.0
non uniform	1.5	1.75	2.0	2.5

Examples of torque characteristic of driving machines:

- uniform: Electric motors with soft starting, steam turbines
- uniform with moderate shock loads: Electric motors without soft starting, hydraulic motors, gas and water turbines
- non uniform: Internal-combustion engines

Examples of torque characteristic in driven machines:

- uniform: Generators, centrifugal pumps for light fluids
- uniform with moderate shock loads: Centrifugal pumps for viscous fluids, elevators, machine tool drives, centrifuges, extruders, blowers, crane drives
- non uniform: Excavators, kneaders, conveyor systems, presses, mills
- very rough: Crushers, excavators, shredders, iron/smelting machinery

Temperature factor FT												
Coupling	Elastomer material	Low temperature °C	Temperature T_a on the coupling									
			under -30 °C	-30 °C up to 50 °C	up to 60 °C	up to 70 °C	up to 80 °C	up to 90 °C	up to 100 °C	up to 110 °C	up to 120 °C	
N-EUPEX	NBR	-30	-	1.0	1.0	1.0	1.0	1.0	-	-	-	-
N-EUPEX	NR	-50	1.1 ¹⁾	1.0	-	-	-	-	-	-	-	-
N-EUPEX	HNBR	-10	-	1.0	1.0	1.0	1.0	1.0	1.25	1.25	-	-
N-EUPEX	TPU	-50	1.0	1.0	1.05	1.10	1.15	-	-	-	-	-
N-EUPEX DS	NBR	-30	-	1.0	1.0	1.0	1.0	-	-	-	-	-
RUPEX	NBR	-30	-	1.0	1.0	1.0	1.0	-	-	-	-	-
RUPEX	NR	-50	1.1	1.0	-	-	-	-	-	-	-	-
RUPEX	HNBR	-10	-	1.0	1.0	1.0	1.0	1.0	1.25	1.25	-	-
N-BIPEX	TPU	-50	1.0	1.0	1.0	1.0	1.0	1.0	1.0	1.3	1.5	-
ELPEX	NR	-40	1.1	1.0	1.25	1.40	1.60	-	-	-	-	-
ELPEX-B	NR	-50	1.1	1.0	-	-	-	-	-	-	-	-
ELPEX-B	CR	-15	-	1.0	1.0	1.0	-	-	-	-	-	-
ELPEX-S SN, NN, WN	NR	-40	1.1	1.0	1.25	1.40	1.60	-	-	-	-	-
ELPEX-S NX	VMQ	-40	1.1	1.0	1.0	1.0	1.0	1.1	1.25	1.4	1.6	-

- NR = natural rubber, natural-synthetic rubber mixture
- NBR = nitril-butadiene-rubber (Perbunan)
- HNBR = hydrated acrylonitrile butadiene rubber
- CR = chloroprene rubber (FRAS fire-resistant and anti-static)
- VMQ = silicone
- TPU = polyurethane

¹⁾ The N-EUPEX coupling is not suitable for shock loads when used at low temperatures.

$$\text{Coupling size } T_{KN} \geq T_N \cdot \text{FB} \cdot \text{FT}$$

In the case of ARPEX and ZAPEX coupling types, no temperature factor (FT = 1.0) need be taken into account.

Coupling load at maximum and overload conditions

The maximum torque is the highest load acting on the coupling in normal operation. Maximum torques at a frequency of up to 25 times an hour are permitted and must be lower than the maximum coupling torque. Examples of maximum torque conditions are: Starting operations, stopping operations or usual operating conditions with maximum load.

$$T_{Kmax} \geq T_{Max} \cdot \text{FT}$$

Overload torques are maximum loads which occur only in combination with special, infrequent operating conditions. Examples of overload torque conditions are: Motor short circuit, emergency stop or blocking because of component breakage. Overload torques at a frequency of once a month are permitted and must be lower than the maximum overload torque of the coupling. The overload condition may last only a short while, i.e. fractions of a second.

$$T_{KOL} \geq T_{OL} \cdot \text{FT}$$

Coupling load due to dynamic torque load

Applying the frequency factor FF, the dynamic torque load must be lower than the coupling fatigue torque.

Dynamic torque load

$$T_{KW} \geq T_W \cdot \text{FF}$$

Frequency of the dynamic torque load $f_{err} \leq 10$ Hz frequency factor FF = 1.0

Frequency of the dynamic torque load $f_{err} > 10$ Hz frequency factor FF = $\sqrt{(f_{err}/10 \text{ Hz})}$

For the ZAPEX and ARPEX series, the frequency factor is always FF = 1.0.

SELECTION OF THE COUPLING SIZE

E

Checking the maximum speed

For all load situations $n_{K_{max}} \geq n_{max}$

Checking permitted shaft misalignment

For all load situations, the actual shaft misalignment must be less than the permitted shaft misalignment.

Checking bore diameter, mounting geometry and coupling design

The check must be made on the basis of the dimension tables. The maximum bore diameter applies to parallel keyways to DIN 6885. For other keyway geometries, the maximum bore diameter can be reduced.

On request, couplings with adapted geometry can be provided.

Coupling behavior under overload conditions

The ZAPEX, N-ARPEX, ARPEX, N-EUPEX, RUPEX and N-BIPEX coupling series can withstand overloads until the breakage of metal parts. These coupling series are designated as fail-safe.

The N-EUPEX DS, ELPEX-B, ELPEX-S and ELPEX coupling series throw overload. The elastomer element of these couplings is irreparably damaged without damage to metal parts when subjected to excessive overload.

These coupling series are designated as non-fail-safe. These types that fail can be fitted with a so-called fail-safe device. This additional component enables emergency operation, even after the rubber element of the coupling has been irreparably damaged.

Checking shaft-hub connection

The torques specified in the tables of power ratings data of the coupling series do not necessarily apply to the shaft-hub connection. Depending on the shaft-hub connection, proof of form stability is required. Flender recommends obtaining proof of form strength by using calculation methods in accordance with the current state of the art.

Fitting recommendations for the shaft-hub connection are given in the **Appendix**.

The coupling hub is frequently fitted flush with the shaft end face. If the shaft projects, the risk of collision with other coupling parts must be checked. If the shaft is set back, in addition to the load-bearing capacity of the shaft-hub connection, the correct positioning of the hub must be ensured as well. If the bearing hub length is insufficient, restorative forces may cause tilting movements and so wear to and impairment of the axial retention. Also, the position of the set screw to be positioned on sufficient shaft or parallel key material must be noted.

Shaft-hub connection	Suggestion for calculation method
Keyway connection to DIN 6885-1	DIN 6892
Shrink fit	DIN 7190
Spline to DIN 5480	
Bolted flange connection	VDI 2230
Flange connection with close-fitting bolts	

Checking low temperature and chemically aggressive environment

The minimum permitted coupling temperature is specified in the Temperature factor FT table. In the case of chemically aggressive environments, please consult the manufacturer.

FEATURES OF THE STANDARD TYPE

E

Couplings	Features of the standard type
All coupling series except ARPEX clamping hubs and FLUDEX with keyway to ASME B17.1	Bore tolerance H7
N-ARPEX and ARPEX clamping hubs	Bore tolerance G6 (suitable for shaft tolerance h6)
FLUDEX couplings with keyway to ASME B17.1	Hollow shafts: bore tolerance K7 other parts: bore tolerance M7
All coupling series with bore diameter - imperial	Parallel keyway to ASME B17.1
Bore diameter metric in the case of ZAPEX, N-ARPEX and ARPEX coupling series as well as coupling hubs with applied brake disks or brake drums of the N-EUPEX and RUPEX series	Parallel keyway to DIN 6885-1 keyway width P9
Bore diameter metric in the case of the N-EUPEX, RUPEX, N-BIPEX, ELPEX-S, ELPEX-B, ELPEX, FLUDEX coupling series	Parallel keyway to DIN 6885-1 keyway width JS9
All coupling series except FLUDEX	Axial locking by means of set screw
FLUDEX coupling series	Axial lock by means of set screw or end washer
All coupling series	Balancing in accordance with half parallel key standard
ZAPEX, N-ARPEX, ARPEX, N-EUPEX, RUPEX, N-BIPEX, ELPEX-S, ELPEX-B and ELPEX coupling series	Balancing quality G16
FLUDEX coupling series	Balancing quality G6.3
SIPEX and BIPEX-S coupling series	Balancing quality G6.3 for 3600 rpm
All series	Unpainted
All series	Preservation with cleaning emulsion
FLUDEX couplings	Fuse 140 °C

Configurator

The article number can be obtained with the help of the Configurator. The coupling can be selected in a product configurator and specified using selection menus.

The coupling can be selected via "Technical selection" (technical selection) or via "Direct selection" (via article no.).

The Configurator is available under flender.com.

TORSIONALLY RIGID GEAR COUPLINGS

ZAPEX ZW SERIES



General	4/3
Benefits	4/3
Application	4/3
Design and configurations	4/4
Function	4/4
Technical specifications	4/5
<hr/>	
Type ZWN	4/6
Type ZZS	4/8
Type ZZW	4/10
Type ZWH	4/12
Type ZWBT	4/13
Type ZWBG	4/14
Type ZWB	4/15
Type ZWTR	4/16
Type ZBR	4/17
Type ZWS	4/18
Type ZWNV	4/19
Type ZWSE	4/20
Customized hub design	4/21
Spare and wear parts	4/23



ZAPEX ZW
FLENDER

GENERAL



Coupling suitable for use in potentially explosive atmospheres.

Complies with the current ATEX Directive for:

CE  II 2G Ex h IIC T6 ... T5 Gb X

 II 2D Ex h IIIC T85 °C ... 100 °C Db X

 I M2 Ex h Mb X

Benefits

ZAPEX gear couplings link machine shafts and compensate for shaft misalignment with weak restorative forces. High transmissible torque combined with compactness and light weight are characteristic of ZAPEX couplings. ZAPEX coupling types are constructed on a modular principle.

This means that application-specific solutions can be delivered quickly. ZAPEX couplings require very little maintenance. Regular grease or oil changes at the prescribed intervals prolongs the service life of the coupling.

Application

ZAPEX couplings are especially suited for operation in harsh operating conditions, such as drives in the iron smelting or cement industry.

ZAPEX couplings are suitable for reverse operation and horizontal mounting positions and, in the case of type ZWNV, for vertical mounting positions.

GENERAL

Design and configurations

4

A ZAPEX coupling comprises two hub sections with external teeth which are mounted on the machine shafts. Each set of external teeth engages in a flanged socket with mating internal teeth. The flanged sleeves are connected via two flanges with close-fitting bolts.

The teeth are lubricated with oil or grease. On the ZAPEX type ZW, DUO sealing rings are used to seal the tooth space. The DUO sealing rings prevent the lubricant from escaping and dirt from entering the tooth space. The parallel keyways must be sealed during assembly to prevent lubricant from escaping.

Customized hub designs are described after the types.

Type	Description
ZWN	Standard type
ZZS	with adapter
ZZW	with intermediate shaft
ZWH	with coupling sleeve
ZWBT	with offset brake disk
ZWBG	with straight brake disk
ZWB	with brake drum
ZWTR	for rope drums
ZBR	with shear pins
ZWS	Clutch
ZWNV	Vertical type
ZWSE	Simple clutch-coupling combination

Further application-specific coupling types are available; dimension sheets for and information on these are available on request.

Function

The torque is transmitted through the coupling teeth. The teeth are crowned, so angular displacement per tooth plane is possible. Radial displacement can be compensated for via the space VA between the tooth planes. The internal teeth of the flanged sleeves are significantly wider than the external teeth of the hub parts, permitting a relatively high axial misalignment.

A small angular misalignment on the coupling teeth results in an advantageous distribution of the lubricant film and a very low wear rate. This favorable condition can be deliberately set by aligning the drive with the machine shafts with a slight radial misalignment.

Technical specifications

Power ratings						
Size	Rated torque	Maximum torque	Overload torque	Fatigue torque	Torsional stiffness ZW	Permitted axial shaft misalignment ΔK_a
	T_{KN} Nm	T_{Kmax} Nm	T_{KOL} Nm	T_{KW} Nm	C_{Tdyn} kNm/rad	
112	1300	2600	5200	520	2000	1.0
128	2500	5000	10000	1000	3600	1.0
146	4300	8600	17200	1720	6900	1.0
175	7000	14000	28000	2800	9360	1.0
198	11600	23200	46400	4640	15600	1.0
230	19000	38000	76000	7600	26300	1.0
255	27000	54000	108000	10800	33400	1.5
290	39000	78000	156000	15600	44000	1.5
315	54000	108000	216000	21600	64100	1.5
342	69000	138000	276000	27600	81600	1.5
375	98000	196000	392000	39200	115600	1.5
415	130000	260000	520000	52000	106000	1.5
465	180000	360000	720000	72000	134600	2.0
505	250000	500000	1000000	100000	168700	2.0
545	320000	640000	1280000	128000	216900	2.0
585	400000	800000	1600000	160000	263200	2.0
640	510000	1020000	2040000	204000	356000	2.0
690	660000	1320000	2640000	264000	431000	2.0
730	790000	1580000	3160000	316000	538000	2.0
780	1000000	2000000	4000000	400000	696000	3.0
852	1200000	2400000	4800000	480000	926000	3.0
910	1600000	3200000	6400000	640000	1118000	3.0
1020	1900000	3800000	7600000	760000	1339000	3.0
1080	2200000	4400000	8800000	880000	1605000	3.0
1150	2700000	5400000	10800000	1080000	2120000	3.0
1160	3350000	6700000	13400000	1340000	2474000	3.0
1240	3800000	7600000	15200000	1520000	3079000	3.0
1310	4600000	9200000	18400000	1840000	3693000	4.0
1380	5300000	10600000	21200000	2120000	4383000	4.0
1440	6250000	12500000	25000000	2500000	5056000	4.0
1540	7200000	14400000	28800000	2880000	6115000	4.0

In the case of type ZWTR, the rated torques which deviate from the above are specified in the dimension table.

The stated torsional stiffness "ZW" applies to coupling types ZWN and ZWNV.
Torsional stiffness of the remaining types on request.

The axial misalignment ΔK_a must be understood as the maximum permitted enlargement of the hub distance S of the coupling.

The axial misalignment for the types ZWBT, ZWBG and ZWNV is $1/2 \cdot \Delta K_a$.

Angular misalignment ΔK_w

Types ZWN, ZZS, ZZW, ZWH, ZWB, ZBR, ZWS: $\Delta K_w = 1^\circ$

Types ZWBT and ZWBG: $\Delta K_w = 0.2^\circ$

Type ZWSE: $\Delta K_w = 0.4^\circ$

Radial misalignment ΔK_r

Types ZWN, ZZS, ZZW, ZWH, ZWB, ZBR, ZWS:

$\Delta K_r \leq VA \cdot \tan 1^\circ$

Types ZWBT and ZWBG: $\Delta K_r \leq VA \cdot \tan 0,2^\circ$

Type ZWSE: $\Delta K_r \leq VA \cdot 0.4^\circ$

For the tooth distance VA, see the relevant table for the subassembly.

TYPE ZWN

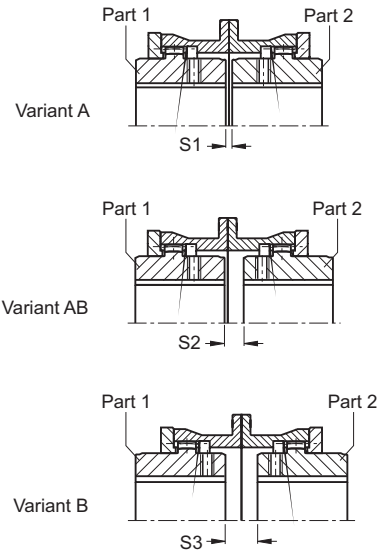
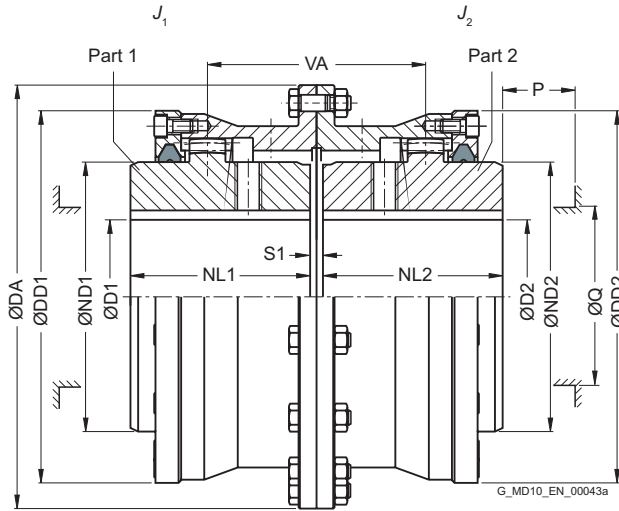

Size	Rated torque T_{KN} Nm	Maximum speed n_{Kmax} rpm	Dimensions in mm													Mass moment of inertia J_1/J_2 kgm ²	Article no. ¹⁾			Weight m kg
			D1, D2 Keyway DIN 6885-1		DA	ND1/ND2	NL1/NL2	DD1/DD2	S1	S2	S3	VA	Q	P	Type		A	B	AB	
			min.	max.																
112	1300	9400	0	49	143	65	50	110	6	-	-	56	50	35	0.007	2LC0300-0AA	2LC0300-0AB	2LC0300-0AC	5.8	
128	2500	8300	0	61	157	80	60	128	6	13	20	73	65	45	0.014	2LC0300-1AA	2LC0300-1AB	2LC0300-1AC	7.9	
146	4300	7300	0	72	177	95	75	146	6	13	20	88	75	45	0.021	2LC0300-2AA	2LC0300-2AB	2LC0300-2AC	11.5	
175	7000	6400	0	85	215	112	90	175	8	14	20	104	85	50	0.049	2LC0300-3AA	2LC0300-3AB	2LC0300-3AC	19	
198	11600	5500	0	100	237	135	100	198	8	19	30	119	110	50	0.086	2LC0300-4AA	2LC0300-4AB	2LC0300-4AC	26.5	
230	19000	4700	0	120	265	160	110	230	8	20	32	130	135	50	0.16	2LC0300-5AA	2LC0300-5AB	2LC0300-5AC	37	
255	27000	4100	0	140	294	185	125	255	10	25	40	150	160	50	0.26	2LC0300-6AA	2LC0300-6AB	2LC0300-6AC	49	
290	39000	3700	70	160	330	210	140	290	10	30	50	170	180	60	0.51	2LC0300-7AA	2LC0300-7AB	2LC0300-7AC	72	
315	54000	3300	80	175	366	230	160	315	10	30	50	190	200	60	0.81	2LC0300-8AA	2LC0300-8AB	2LC0300-8AC	99	
342	69000	3000	90	195	392	255	180	340	12	42	72	222	225	60	1.2	2LC0301-0AA	2LC0301-0AB	2LC0301-0AC	125	
375	98000	2700	100	220	430	290	200	375	12	42	72	242	260	60	2	2LC0301-1AA	2LC0301-1AB	2LC0301-1AC	170	
415	130000	2500	120	240	478	320	220	415	12	74	136	294	285	80	3.1	2LC0301-2AA	2LC0301-2AB	2LC0301-2AC	225	
465	180000	2200	140	270	528	360	240	465	16	96	176	336	325	80	5.2	2LC0301-3AA	2LC0301-3AB	2LC0301-3AC	300	
505	250000	2000	160	300	568	400	260	505	16	106	196	366	365	80	7.7	2LC0301-4AA	2LC0301-4AB	2LC0301-4AC	380	
545	320000	1800	180	330	620	440	280	545	16	126	236	406	405	80	12	2LC0301-5AA	2LC0301-5AB	2LC0301-5AC	490	
585	400000	1700	210	360	660	480	310	585	20	150	280	460	445	80	17	2LC0301-6AA	2LC0301-6AB	2LC0301-6AC	620	
640	510000	1600	230	360	738	480	330	640	20	149	278	445	475	90	25	2LC0301-7AA	2LC0301-7AB	2LC0301-7AC	780	
			>360	390		520						475							27	800
690	660000	1450	250	390	788	520	350	690	20	166	312	475	515	90	35	2LC0301-8AA	2LC0301-8AB	2LC0301-8AC	950	
			>390	420		560						515							38	980
730	790000	1350	275	420	834	560	380	730	20	180	340	515	555	90	48	2LC0302-0AA	2LC0302-0AB	2LC0302-0AC	1150	
			>420	450		600						555							52	1200

Configurable variants ¹⁾

- ØD1 Without finished bore
With finished bore
- ØD2 Without finished bore
With finished bore

¹⁾ To identify complete item numbers specifying the available finish boring options and – if necessary – further order options, please use our configurators on flender.com.

↗ For online configuration on flender.com, click on the item no.

Size	Rated torque T_{KN} Nm	Maximum speed n_{Kmax} rpm	Dimensions in mm													Mass moment of inertia J_1/J_2 kgm ²	Article no. ¹⁾			Weight m kg
			D1, D2 Keyway DIN 6885-1		DA	ND1/ND2	NL1/NL2	DD1/DD2	S1	S2	S3	VA	Q	P	Type					
			min.	max.											A		B	AB		
780	1000000	1250	300	450	900	600	400	780	25	176	327	576	555	110	68	2LC0302-1AA	2LC0302-1AB	2LC0302-1AC	1450	
			>450	490		650							595		77				1450	
852	1200000	1150	325	490	970	650	420	850	25	185	345	605	595	110	100	2LC0302-2AA	2LC0302-2AB	2LC0302-2AC	1750	
			>490	535		710							655		110				1800	
910	1600000	1050	350	535	1030	710	450	910	25	215	405	665	655	110	140	2LC0302-3AA	2LC0302-3AB	2LC0302-3AC	2100	
			>535	570		750							695		145				2150	
1020	1900000	1000	375	570	1112	750	480	1020	25	213	401	693	695	130	200	2LC0302-4AA	2LC0302-4AB	2LC0302-4AC	2600	
			>570	600		800							735		220				2800	
1080	2200000	950	400	600	1162	800	500	1080	30	226	422	726	735	135	255	2LC0302-5AA	2LC0302-5AB	2LC0302-5AC	3100	
			>600	650		860							795		285				3200	
1150	2700000	900	425	650	1222	860	520	1150	30	238	446	758	795	135	330	2LC0302-6AA	2LC0302-6AB	2LC0302-6AC	3600	
			>650	705		930							865		380				3700	
1160	3350000	850	450	650	1292	860	550	1160	30	260	490	810	795	135	420	2LC0302-7AA	2LC0302-7AB	2LC0302-7AC	4000	
			>650	705		930							865		450				4100	
1240	3800000	800	>705	750	1400	930	580	1240	30	250	470	830	910	155	500	2LC0302-8AA	2LC0302-8AB	2LC0302-8AC	4300	
			>705	750		990							865		580				4900	
1310	4600000	750	>750	800	1470	990	610	1310	35	265	495	875	910	155	580	2LC0303-0AA	2LC0303-0AB	2LC0303-0AC	5000	
			>750	800		1055							865		700				5300	
1380	5300000	700	>800	850	1540	1120	640	1380	35	275	515	915	975	155	730	2LC0303-1AA	2LC0303-1AB	2LC0303-1AC	5600	
			>800	850		1310							865		770				5700	
1440	6250000	670	>850	890	1600	1120	670	1440	35	295	555	965	910	155	840	2LC0303-2AA	2LC0303-2AB	2LC0303-2AC	5900	
			>850	890		1370							865		930				6200	
1540	7200000	630	>890	940	1710	1120	700	1540	35	275	515	975	1030	175	930	2LC0303-3AA	2LC0303-3AB	2LC0303-3AC	6500	
			>890	940		1380							975		1000				6800	
			>940	995		1170		1430					1080		1150				7100	
			>940	995		1310							1030		1200				7500	
													975		1250				7600	
													1030		1300				7700	
													1150		1450				8200	
													1030		1550				8800	
													1080		1600				8900	
													1150		1700				9200	
													1220		1900				9600	

Configurable variants ¹⁾

- ØD1 Without finished bore
With finished bore
- ØD2 Without finished bore
With finished bore

Notes

- Mass moments of inertia apply to a coupling half with maximum bore diameter.
- Weights apply to the entire coupling with maximum bores.
- Q Diameter required for renewing the sealing rings.
P Length required for renewing the sealing rings.

Ordering example

- ZAPEX ZWN coupling, size 146, variant A
- Part 1: Bore 40H7mm, keyway to DIN 6885-1 P9 and set screw
- Part 2: Bore 45K7 mm, keyway to DIN 6885-1 P9 and set screw

Article no.: 2LC0300-2AA99-0AA0-Z L0W+M1A+M13

¹⁾ To identify complete item numbers specifying the available finish boring options and – if necessary – further order options, please use our configurators on flender.com.

↗ For online configuration on flender.com, click on the item no.

TYPE ZZS

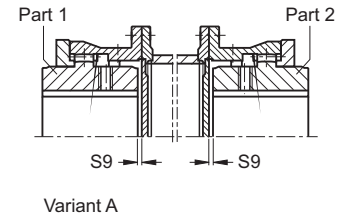
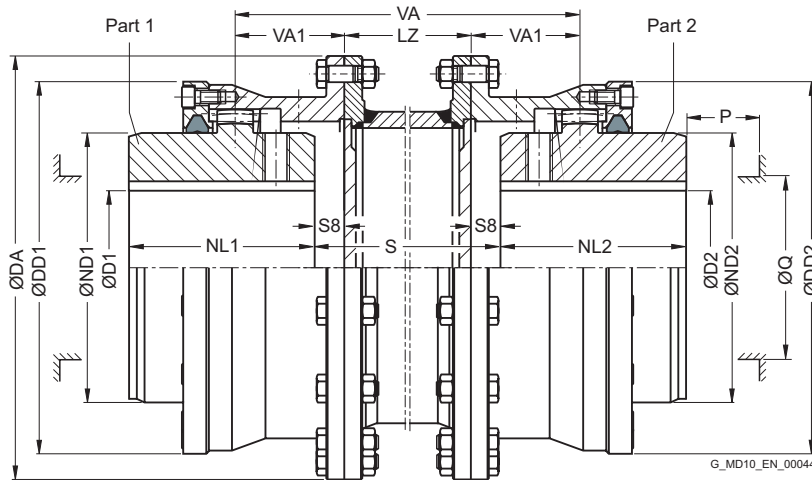

Variant B

Size	Rated torque T_{KN} Nm	Dimensions in mm												➤ Article no. ¹⁾		Weight each 100 mm pipe	
		D1, D2 Keyway DIN 6885-1		DA	ND1/ND2	NL1/NL2	DD1/DD2	S8	S9	VA1	Q	P	LZ	Type		m	kg
		min.	max.											A	B		
112	1300	0	49	143	65	50	110	3	3	28	50	35	120	2LC0300-0AD	2LC0300-0AE	0.8	9.4
128	2500	0	61	157	80	60	128	10	3	36.5	65	45	120	2LC0300-1AD	2LC0300-1AE	1.3	12.5
146	4300	0	72	177	95	75	146	10	3	44	75	45	120	2LC0300-2AD	2LC0300-2AE	1.8	17
175	7000	0	85	215	112	90	175	10	4	52	85	50	130	2LC0300-3AD	2LC0300-3AE	2.3	27.5
198	11600	0	100	237	135	100	198	15	4	59.5	110	50	130	2LC0300-4AD	2LC0300-4AE	3.5	37
230	19000	0	120	265	160	110	230	16	4	65	135	50	130	2LC0300-5AD	2LC0300-5AE	4.5	50
255	27000	0	140	294	185	125	255	20	5	75	160	50	140	2LC0300-6AD	2LC0300-6AE	6.3	68
290	39000	70	160	330	210	140	290	25	5	85	180	60	140	2LC0300-7AD	2LC0300-7AE	7.2	93
315	54000	80	175	366	230	160	315	25	5	95	200	60	180	2LC0300-8AD	2LC0300-8AE	9.1	135
342	69000	90	195	392	255	180	340	36	6	111	225	60	180	2LC0301-0AD	2LC0301-0AE	12	170
375	98000	100	220	430	290	200	375	36	6	121	260	60	180	2LC0301-1AD	2LC0301-1AE	15	220
415	130000	120	240	478	320	220	415	68	6	147	285	80	200	2LC0301-2AD	2LC0301-2AE	17	295
465	180000	140	270	528	360	240	465	88	8	168	325	80	200	2LC0301-3AD	2LC0301-3AE	19	380
505	250000	160	300	568	400	260	505	98	8	183	365	80	200	2LC0301-4AD	2LC0301-4AE	24	470
545	320000	180	330	620	440	280	545	118	8	203	405	80	220	2LC0301-5AD	2LC0301-5AE	30	640
585	400000	210	360	660	480	310	585	140	10	230	445	80	220	2LC0301-6AD	2LC0301-6AE	33	780
640	510000	230	360	738	480	330	640	139	10.0	239.5	445	90	250	2LC0301-7AD	2LC0301-7AE	39	1010
		>360	390		520						475						1050
690	660000	250	390	788	520	350	690	156	10.0	258	475	90	250	2LC0301-8AD	2LC0301-8AE	48	1200
		>390	420		560						515						1250
730	790000	275	420	834	560	380	730	170	10.0	280	515	90	250	2LC0302-0AD	2LC0302-0AE	51	1450
		>420	450		600						555						1500
780	1000000	300	450	900	600	400	780	163.5	12.5	288	555	110	280	2LC0302-1AD	2LC0302-1AE	55	1850
		>450	490		650						595						1900

Configurable variants ¹⁾

- ØD1 Without finished bore
With finished bore
- ØD2 Without finished bore
With finished bore

¹⁾ To identify complete item numbers specifying the available finish boring options and – if necessary – further order options, please use our configurators on flender.com.

➤ For online configuration on flender.com, click on the item no.

Size	Rated torque T_{KN} Nm	Dimensions in mm												Article no. ¹⁾		Weight each 100 mm pipe m	
		D1, D2 Keyway DIN 6885-1		DA	ND1/ ND2	NL1/ NL2	DD1/ DD2	S8	S9	VA1	Q	P	LZ min.	Type		kg	m
		min.	max.											A	B		
852	1200000	325	490	970	650	420	850	172.5	12.5	302.5	595	110	280	2LC0302-2AD	2LC0302-2AE	68	2300
		>490	535		710												2400
910	1600000	350	535	1030	710	450	910	202.5	12.5	332.5	655	110	280	2LC0302-3AD	2LC0302-3AE	94	2800
		>535	570		750												2850
1020	1900000	375	570	1112	750	480	1020	200.5	12.5	346.5	695	130	380	2LC0302-4AD	2LC0302-4AE		
1080	2200000	400	600	1162	800	500	1080	211	15.0	363	735	135	380	2LC0302-5AD	2LC0302-5AE		
		>600	650		860												795
1150	2700000	425	650	1222	860	520	1150	223	15.0	379	795	135	380	2LC0302-6AD	2LC0302-6AE		
		>650	705		930												865
1160	3350000	450	650	1292	860	550	1160	245	15.0	405	795	135	380	2LC0302-7AD	2LC0302-7AE		
		>650	705		930												865
1240	3800000	475	705	1400	930	580	1240	235	15.0	415	865	155	400	2LC0302-8AD	2LC0302-8AE		
		>705	750		990												910
1310	4600000	500	705	1470	930	610	1310	247.5	17.5	437.5	865	155	400	2LC0303-0AD	2LC0303-0AE		
		>705	750		1055												910
1380	5300000	525	750	1540	990	640	1380	257.5	17.5	457.5	910	155	400	2LC0303-1AD	2LC0303-1AE		
		>750	800		1120												1030
1440	6250000	550	800	1600	1055	670	1440	277.5	17.5	482.5	975	155	400	2LC0303-2AD	2LC0303-2AE		
		>800	850		1170												1080
1540	7200000	575	850	1710	1120	700	1540	257.5	17.5	487.5	1030	175	600	2LC0303-3AD	2LC0303-3AE		
		>850	890		1240												1150
		>940	995		1310		1610				1220						

Configurable variants ¹⁾

- ØD1 Without finished bore
With finished bore
- ØD2 Without finished bore
With finished bore

Notes

- Mass moments of inertia apply to a coupling half with maximum bore diameter.
- Weights apply to maximum bores and an adapter length of LZ min.
- Weights from size 1020 on request.
- $VA = 2 \cdot VA1 + LZ$
- Mass moment of inertia on request.
- Maximum speed, limited by weight and critical adapter speed, on request.
- Q Diameter required for renewing the sealing rings.
P Length required for renewing the sealing rings.

Ordering example

- ZAPEX ZZS coupling, size 146, variant B
- Part 1: Bore 40H7mm, keyway to DIN 6885-1 P9 and set screw
- Part 2: Bore 45K7 mm, keyway to DIN 6885-1 P9 and set screw

Article no.: 2LC0300-2AE99-0AZ0-Z L0W+M1A+Q0Y+M13
Plain text to Q0Y: 250 mm (dimension S)

¹⁾ To identify complete item numbers specifying the available finish boring options and – if necessary – further order options, please use our configurators on fender.com.

➤ For online configuration on fender.com, click on the item no.

TYPE ZZW

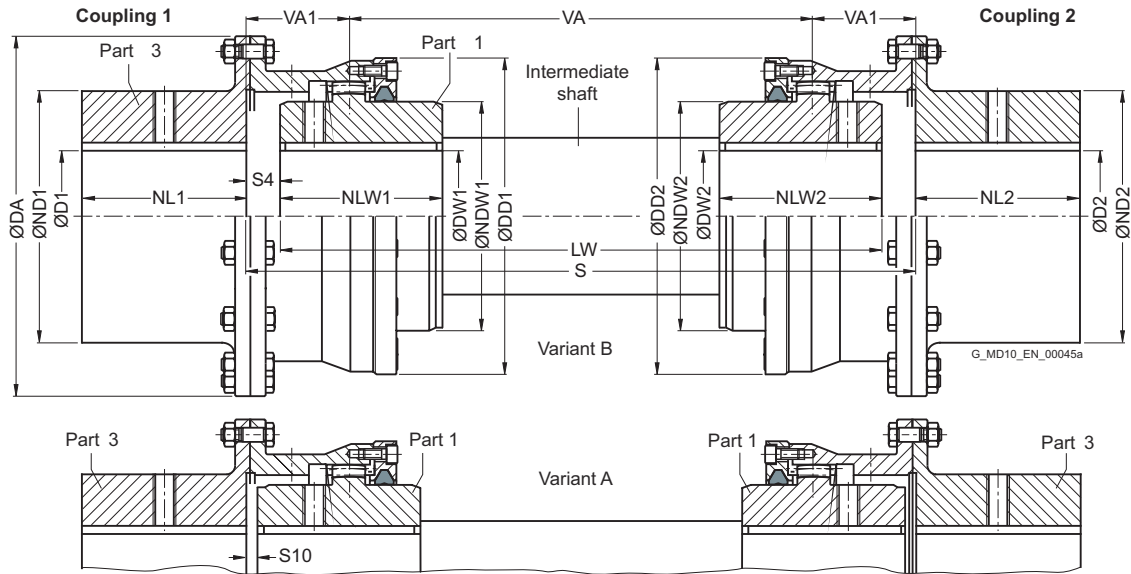

Size	Rated torque T_{KN} Nm	Dimensions in mm											Article no. ¹⁾		Weight m kg	
		D1, D2 Keyway DIN 6885-1		DA	ND1/ ND2	NL1/ NL2/ NLW1/ NLW2	DW1, DW2 Keyway DIN 6885-1		NDW1/ NDW2	DD1/ DD2	S4	S10	VA1	Type		
		min.	max.				min.	max.						A		B
112	1300	20	61	143	80	50	0	49	65	110	12.5	12.5	37.5	2LC0300-0BD	2LC0300-0BE	5.1
128	2500	25	72	157	95	60	0	61	80	128	12.5	5.5	39	2LC0300-1BD	2LC0300-1BE	6.8
146	4300	30	85	177	112	75	0	72	95	146	12.5	5.5	46.5	2LC0300-2BD	2LC0300-2BE	9.8
175	7000	35	100	215	135	90	0	85	112	175	12.5	6.5	54.5	2LC0300-3BD	2LC0300-3BE	16.5
198	11600	40	120	237	160	100	0	100	135	198	17.5	6.5	62	2LC0300-4BD	2LC0300-4BE	23
230	19000	50	140	265	185	110	0	120	160	230	18.5	6.5	67.5	2LC0300-5BD	2LC0300-5BE	32
255	27000	60	160	294	210	125	0	140	185	255	23.5	8.5	78.5	2LC0300-6BD	2LC0300-6BE	43
290	39000	70	175	330	230	140	70	160	210	290	28.5	8.5	88.5	2LC0300-7BD	2LC0300-7BE	61
315	54000	80	195	366	255	160	80	175	230	315	28.5	8.5	98.5	2LC0300-8BD	2LC0300-8BE	86
342	69000	90	220	392	290	180	90	195	255	340	39.5	9.5	114.5	2LC0301-0BD	2LC0301-0BE	115
375	98000	100	240	430	320	200	100	220	290	375	39.5	9.5	124.5	2LC0301-1BD	2LC0301-1BE	150
415	130000	120	270	478	360	220	120	240	320	415	71.5	9.5	150.5	2LC0301-2BD	2LC0301-2BE	205
465	180000	140	300	528	400	240	140	270	360	465	91.5	11.5	171.5	2LC0301-3BD	2LC0301-3BE	275
505	250000	160	330	568	440	260	160	300	400	505	102.5	12.5	187.5	2LC0301-4BD	2LC0301-4BE	350
545	320000	180	360	620	480	280	180	330	440	545	122.5	12.5	207.5	2LC0301-5BD	2LC0301-5BE	450
585	400000	210	360	660	480	310	210	360	480	585	144.5	14.5	234.5	2LC0301-6BD	2LC0301-6BE	540
		>360	390		520		480	570								
640	510000	230	390	738	520	330	230	360	480	640	143.5	14.5	244	2LC0301-7BD	2LC0301-7BE	700
		>390	420		560		>360	390								520
690	660000	250	420	788	560	350	250	390	520	690	160.5	14.5	262.5	2LC0301-8BD	2LC0301-8BE	850
		>420	450		600		>390	420								560
730	790000	275	450	834	600	380	275	420	560	730	176	16	286	2LC0302-0BD	2LC0302-0BE	1050
		>450	490		650		>420	450								600
780	1000000	300	490	900	650	400	300	450	600	780	171.5	20.5	296	2LC0302-1BD	2LC0302-1BE	1300
		>490	535		710		>450	490								650

Configurable variants ¹⁾

- ØD1 Without finished bore
With finished bore
- ØD2 Without finished bore
With finished bore

¹⁾ To identify complete item numbers specifying the available finish boring options and – if necessary – further order options, please use our configurators on flender.com.

➤ For online configuration on flender.com, click on the item no.

Size	Rated torque T_{KN} Nm	Dimensions in mm												Article no. ¹⁾		Weight m kg
		D1, D2 Keyway DIN 6885-1		DA	ND1/ ND2	NL1/ NL2/ NLW1/ NLW2	DW1, DW2 Keyway DIN 6885-1		NDW1/ NDW2	DD1/ DD2	S4	S10	VA1	Type		
		min.	max.				min.	max.						A	B	
852	1200000	325	535	970	710	420	325	490	650	850	180.5	20.5	310.5	2LC0302-2BD	2LC0302-2BE	1550
		>535	570		750		>490	535	710							1650
910	1600000	350	570	1030	750	450	350	535	710	910	210.5	20.5	340.5	2LC0302-3BD	2LC0302-3BE	1900
		>570	600		800		>535	570	750							2000
1020	1900000	375	600	1112	800	480	375	570	750	1020	210.5	22.5	356.5	2LC0302-4BD	2LC0302-4BE	2300
		>600	650		860		>570	600	800							2500
1080	2200000	400	650	1162	860	500	400	600	800	1080	221	25	373	2LC0302-5BD	2LC0302-5BE	2750
		>650	705		930		>600	650	860							2900
1150	2700000	425	650	1222	860	520	425	650	860	1150	233	25	389	2LC0302-6BD	2LC0302-6BE	3100
		>650	705		930		>650	705	930							3200
1160	3350000	450	705	1292	930	550	450	650	860	1160	255	25	415	2LC0302-7BD	2LC0302-7BE	3400
		>705	750		990		>650	705	930							3600
1240	3800000	475	705	1400	930	580	475	705	930	1240	245	25	425	2LC0302-8BD	2LC0302-8BE	3700
		>705	750		990		>705	750	990							4000
1310	4600000	500	750	1470	990	610	500	705	930	1310	257.5	27.5	447.5	2LC0303-0BD	2LC0303-0BE	4200
		>750	800		1055		>705	750	990							4400
1380	5300000	525	800	1540	1055	640	525	750	990	1380	267.5	27.5	467.5	2LC0303-1BD	2LC0303-1BE	4600
		>800	850		1120		>750	800	1055							4900
1440	6250000	550	850	1600	1120	670	550	800	1055	1440	287.5	27.5	492.5	2LC0303-2BD	2LC0303-2BE	5100
		>850	890		1170		>800	850	1120							5300
1540	7200000	575	890	1710	1170	700	575	850	1120	1540	267.5	27.5	497.5	2LC0303-3BD	2LC0303-3BE	5600
		>890	940		1240		>850	890	1170							5700
		>940	1040		1390		>940	995	1310	1610						7700
																8100
																8900

Configurable variants ¹⁾

- ØD1 Without finished bore
With finished bore
- ØD2 Without finished bore
With finished bore

Notes

- $VA = S - 2 \cdot VA1$
- Mass moment of inertia on request.
- Weights apply to either coupling 1 or 2 with maximum bore diameter, without intermediate shaft.
- Maximum speed, limited by weight and critical speed of intermediate shaft, on request.

¹⁾ To identify complete item numbers specifying the available finish boring options and – if necessary – further order options, please use our configurators on flender.com.

↗ For online configuration on flender.com, click on the item no.

Ordering example

- Coupling 1:
ZAPEX ZZW coupling, size 146, variant B,
Part 3: Bore D1 = 45K7 mm, keyway to DIN 6885-1 P9 and set screw, Part 1: Bore DW1 = 45H7 mm, keyway to DIN 6885-1 P9 and set screw.

Article no.: 2LC0300-2BE99-0AA0-Z L1A+M1A+L13

- Intermediate shaft:
Intermediate shaft for ZAPEX coupling ZZW, size 146,
length LW = 570 mm, for shaft distance S = 595 mm
shaft journal Ø45p6 x 75 long; keyway DIN 6885-1.

Article no.: 2LC0308-8XX00-0AA0-Z Y99

Plain text to Y99: DW1 = 45p6 mm, NLW1 = 75 mm,
DW2 = 45p6 mm, NLW2 = 75 mm, LW = 570 mm

- Coupling 2:
ZAPEX ZZW coupling, size 146, variant B,
Part 1: Bore DW2 = 45H7 mm, keyway to DIN 6885-1 P9 and set screw, Part 3: Bore D2 = 45K7 mm, keyway to DIN 6885-1 P9 and set screw.

Article no.: 2LC0300-2BE99-0AA0-Z L1A+M1A+L13

TYPE ZWH

4

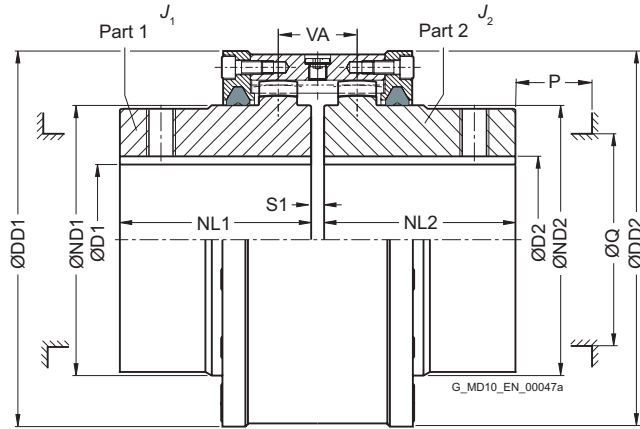

Size	Rated torque T_{KN} Nm	Maximum speed n_{Kmax} rpm	Dimensions in mm									Mass moment of inertia J_1/J_2 kgm ²	Article no. ¹⁾	Weight m kg
			D1, D2 Keyway DIN 6885-1		ND1/ND2	NL1/NL2	DD1/DD2	S1	VA	Q	P			
min.		max.												
112	1300	9400	0	49	65	50	110	6	28	50	35	0.003	2LC0300-0BB	3.5
128	2500	8300	0	61	80	60	128	6	30	65	45	0.007	2LC0300-1BB	5.1
146	4300	7300	0	72	95	75	146	6	33	75	45	0.012	2LC0300-2BB	7.8
175	7000	6400	0	85	112	90	175	8	46	85	50	0.031	2LC0300-3BB	13.5
198	11600	5500	0	100	135	100	198	8	48	110	50	0.056	2LC0300-4BB	20
230	19000	4700	0	120	160	110	230	8	50	135	50	0.11	2LC0300-5BB	28.5
255	27000	4100	0	140	185	125	255	10	55	160	50	0.18	2LC0300-6BB	38
290	39000	3700	70	160	210	140	290	10	58	180	60	0.35	2LC0300-7BB	56
315	54000	3300	80	175	230	160	315	10	62	200	60	0.55	2LC0300-8BB	74
342	69000	3000	90	195	255	180	340	12	70	225	60	0.82	2LC0301-0BB	95
375	98000	2700	100	220	290	200	375	12	72	260	60	1.3	2LC0301-1BB	130
415	130000	2500	120	240	320	220	415	12	76	285	80	2.3	2LC0301-2BB	175
465	180000	2200	140	270	360	240	465	16	90	325	80	4	2LC0301-3BB	245
505	250000	2000	160	300	400	260	505	16	92	365	80	6	2LC0301-4BB	310
545	320000	1800	180	330	440	280	545	16	96	405	80	8.8	2LC0301-5BB	390
585	400000	1700	210	360	480	310	585	20	102	445	80	13	2LC0301-6BB	500
640	510000	1600	230	360	480	330	640	20	105	445	90	18	2LC0301-7BB	620
			>360	390	520					475		19.5		650
690	660000	1450	250	390	520	350	690	20	108	475	90	25.5	2LC0301-8BB	760
			>390	420	560					515		28		790
730	790000	1350	275	420	560	380	730	20	112	515	90	35	2LC0302-0BB	920
			>420	450	600					555		39		950
780	1000000	1250	300	450	600	400	780	25	120	555	110	48	2LC0302-1BB	1150
			>450	490	650					595		57		

Configurable variants ¹⁾

- ØD1 Without finished bore
With finished bore
- ØD2 Without finished bore
With finished bore

Notes

- Larger size couplings on request.
- Mass moments of inertia apply to a coupling half with maximum bore diameter.
- Weights apply to the entire coupling with maximum bores.
- Q Diameter required for renewing the sealing rings.
P Length required for renewing the sealing rings.

Ordering example

- ZAPEX ZWH coupling, size 146
- Part 1: Bore 40H7mm, keyway to DIN 6885-1 P9 and set screw
- Part 2: Bore 45K7 mm, keyway to DIN 6885-1 P9 and set screw

Article no.: 2LC0300-2BB99-0AA0-Z L0W+M1A+M13

¹⁾ To identify complete item numbers specifying the available finish boring options and – if necessary – further order options, please use our configurators on flender.com.

↗ For online configuration on flender.com, click on the item no.

TYPE ZWBT

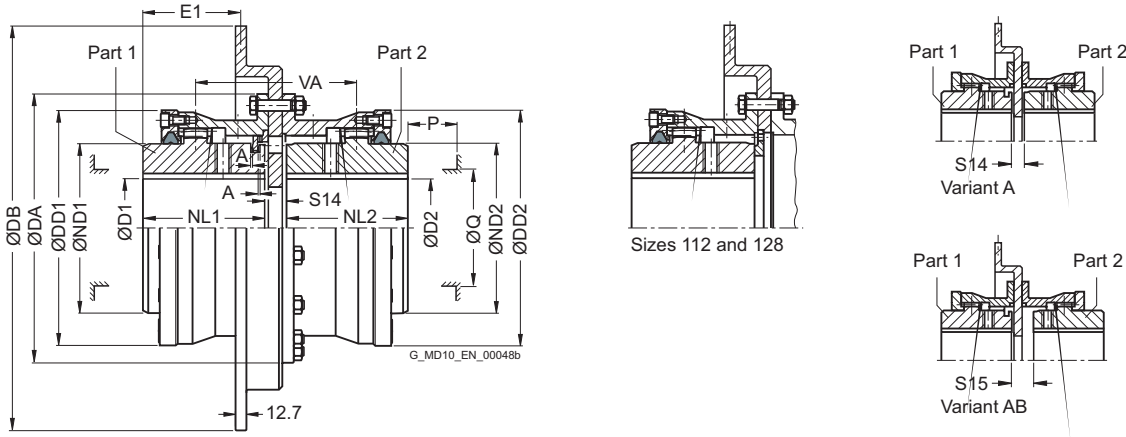

Size	Rated torque T_{KN} Nm	Maximum speed n_{Kmax} rpm	Dimensions in mm													Brake disk		Article no. ¹⁾		Weight m kg	
			D1 Keyway DIN 6885-1 min. max.		D2 Keyway DIN 6885-1 min. max.		DA	ND1/ ND2	NL1/ NL2	DD1/ DD2	S14	S15	A	VA	Q	P	DB	E1	Type		
																			A	AB	
112	1300	3800	0	49	0	49	143	65	50	110	20	-	0.5	70	50	35	300	32.35	2LC0300-0AS	2LC0300-0AT	13
		23									-	73		356			22.35	2LC0300-0AS	2LC0300-0AT	16.5	
128	2500	3200	0	61	0	61	157	80	60	128	23.5	30.5	0.5	90.5	65	45	356	32.85	2LC0300-1AS	2LC0300-1AT	19
		20.5									27.5	87.5		406			29.85	2LC0300-1AS	2LC0300-1AT	21.5	
146	4300	2800	0	65	0	72	177	95	75	146	19	26	0.5	101	75	45	406	43.35	2LC0300-2AS	2LC0300-2AT	25
		22									29	104		457			46.35	2LC0300-2AS	2LC0300-2AT	30	
175	7000	2800	0	80	0	85	215	112	90	175	21	27	0.5	117	85	50	406	59.35	2LC0300-3AS	2LC0300-3AT	33
		24									30	120		457			62.35	2LC0300-3AS	2LC0300-3AT	38	
198	11600	2500	0	95	0	100	237	135	100	198	19	26	0.5	135	110	50	514	62.35	2LC0300-3AS	2LC0300-3AT	43
		24									35	135		457			72.35	2LC0300-4AS	2LC0300-4AT	46	
230	19000	2200	0	117	0	120	265	160	110	230	24	36	0.5	146	135	50	514	82.35	2LC0300-5AS	2LC0300-5AT	62
		24									36	146		610			82.35	2LC0300-5AS	2LC0300-5AT	73	
255	27000	2200	0	140	0	140	294	185	125	255	26	41	1	166	160	50	514	98.35	2LC0300-6AS	2LC0300-6AT	73
		26									41	166		610			98.35	2LC0300-6AS	2LC0300-6AT	84	
290	39000	1850	70	155	70	160	330	210	140	290	26	46	1	186	180	60	610	113.35	2LC0300-7AS	2LC0300-7AT	110
		29									49	189		711			116.35	2LC0300-7AS	2LC0300-7AT	125	
315	54000	1850	80	175	80	175	366	230	160	315	26	46	1	206	200	60	610	133.35	2LC0300-8AS	2LC0300-8AT	135
		29									49	209		711			136.35	2LC0300-8AS	2LC0300-8AT	150	
342	69000	1600	90	195	90	195	392	255	180	340	31	61	1	241	225	60	711	157.35	2LC0301-0AS	2LC0301-0AT	180
375	98000	1600	100	220	100	220	430	290	200	375	31	61	1	261	260	60	711	177.35	2LC0301-1AS	2LC0301-1AT	220
415	130000	1400	120	240	120	240	478	320	220	415	37	99	1	319	285	80	812	203.35	2LC0301-2AS	2LC0301-2AT	320
465	180000	1400	140	270	140	270	528	360	240	465	41	121	1	361	325	80	812	225.35	2LC0301-3AS	2LC0301-3AT	400

Configurable variants ¹⁾

- ØD1 Without finished bore
With finished bore
- ØD2 Without finished bore
With finished bore

Notes

- Mass moment of inertia on request.
- Weights apply to maximum bores.
- Variant limited in displacement and axial movement. Max. displacement 0.2°.
- Q Diameter required for renewing the sealing rings.
P Length required for renewing the sealing rings.

Ordering example

- ZAPEX ZWBT coupling, size 146, variant A, brake disk diameter DB = 457 mm
- Part 1: Bore 40H7mm, keyway to DIN 6885-1 P9 and set screw
- Part 2: Bore 45K7 mm, keyway to DIN 6885-1 P9 and set screw

Article no.: 2LC0300-2AS99-0BA0-Z L0W+M1A+M13

¹⁾ To identify complete item numbers specifying the available finish boring options and – if necessary – further order options, please use our configurators on fletcher.com.

➤ For online configuration on fletcher.com, click on the item no.

TYPE ZWBG

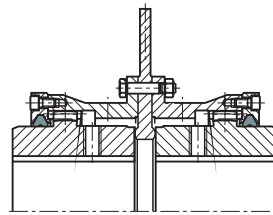
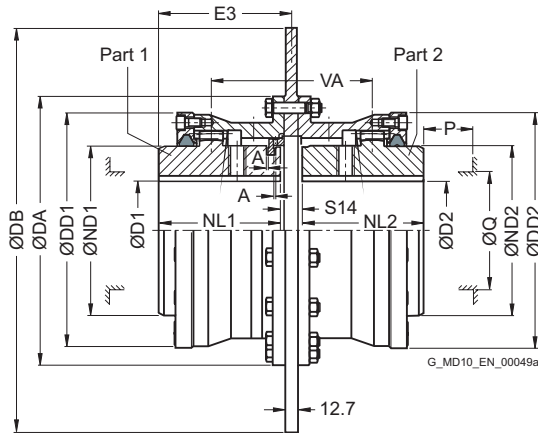

Sizes 112 and 128

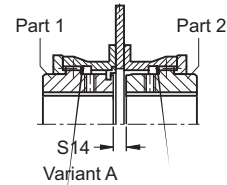

Variant A

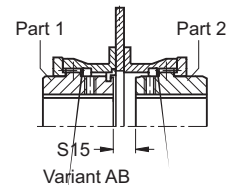

Variant AB

Size	Rated torque T_{KN} Nm	Maximum speed n_{Kmax} rpm	Dimensions in mm													Brake disk		Article no. ¹⁾		Weight m kg		
			D1 Keyway DIN 6885-1 min. max.		D2 Keyway DIN 6885-1 min. max.		DA	ND1/ ND2	NL1/ NL2	DD1/ DD2	S14	S15	A	VA	Q	P	DB	E3	Type			
																			A	AB		
112	1300	3800	0	49	0	49	143	65	50	110	19	-	0.5	69	50	35	300	59.5	2LC0300-0AU	2LC0300-0AV	13	
		3200									22	-		72			356	61	2LC0300-0AU	2LC0300-0AV	16	
128	2500	3200	0	61	0	61	157	80	60	128	22	29	0.5	89	65	45	356	71	2LC0300-1AU	2LC0300-1AV	18	
		2800									19	26		86			406	69.5	2LC0300-1AU	2LC0300-1AV	20.5	
146	4300	2800	0	65	0	72	177	95	75	146	19	26	0.5	101	75	45	406	84.5	2LC0300-2AU	2LC0300-2AV	24	
		2500									22	29		104			457	86	2LC0300-2AU	2LC0300-2AV	28.5	
175	7000	2800	0	80	0	85	215	112	90	175	21	27	0.5	117	85	50	406	100.5	2LC0300-3AU	2LC0300-3AV	31	
		2500									24	30		120			457	102	2LC0300-3AU	2LC0300-3AV	35	
198	11600	2500	0	95	0	100	237	135	100	198	24	35	0.5	135	110	50	514	102	2LC0300-3AU	2LC0300-3AV	40	
		2200									24	35		135			457	112	2LC0300-4AU	2LC0300-4AV	43	
230	19000	2200	0	117	0	120	265	160	110	230	24	36	0.5	146	135	50	514	122	2LC0300-5AU	2LC0300-5AV	58	
		1850									24	36		146			610	122	2LC0300-5AU	2LC0300-5AV	66	
255	27000	2200	0	140	0	140	294	185	125	255	26	41	1	166	160	50	514	138	2LC0300-6AU	2LC0300-6AV	69	
		1850									26	41		166			610	138	2LC0300-6AU	2LC0300-6AV	77	
290	39000	1850	70	155	70	160	330	210	140	290	26	46	1	186	180	60	610	153	2LC0300-7AU	2LC0300-7AV	100	
		1600									29	49		189			711	154.5	2LC0300-7AU	2LC0300-7AV	110	
315	54000	1850	80	175	80	175	366	230	160	315	26	46	1	206	200	60	610	173	2LC0300-8AU	2LC0300-8AV	130	
		1600									29	49		209			711	174.5	2LC0300-8AU	2LC0300-8AV	140	
342	69000	1600	90	195	90	195	392	255	180	340	31	61	1	241	225	60	711	195.5	2LC0301-0AU	2LC0301-0AV	165	
375	98000	1600	100	220	100	220	430	290	200	375	31	61	1	261	260	60	711	215.5	2LC0301-1AU	2LC0301-1AV	205	
415	130000	1400	120	240	120	240	478	320	220	415	37	99	1	319	285	80	812	238.5	2LC0301-2AU	2LC0301-2AV	280	
465	180000	1400	140	270	140	270	528	360	240	465	41	121	1	361	325	80	812	260.5	2LC0301-3AU	2LC0301-3AV	360	

Configurable variants ¹⁾

- ØD1 Without finished bore
With finished bore
- ØD2 Without finished bore
With finished bore

Notes

- Mass moment of inertia on request.
- Weights apply to maximum bores.
- Variant limited in displacement and axial movement. Max. displacement 0.2°.
- Modified brake disk dimensions on request
- Q Diameter required for renewing the sealing rings.
P Length required for renewing the sealing rings.

Ordering example

- ZAPEX ZWBG coupling, size 146, variant A, brake disk diameter DB = 457 mm
- Part 1: Bore 40H7mm, keyway to DIN 6885-1 P9 and set screw
- Part 2: Bore 45K7 mm, keyway to DIN 6885-1 P9 and set screw

Article no.: 2LC0300-2AU99-0BA0-Z L0W+M1A+M13

¹⁾ To identify complete item numbers specifying the available finish boring options and – if necessary – further order options, please use our configurators on flender.com.

↗ For online configuration on flender.com, click on the item no.

TYPE ZWB

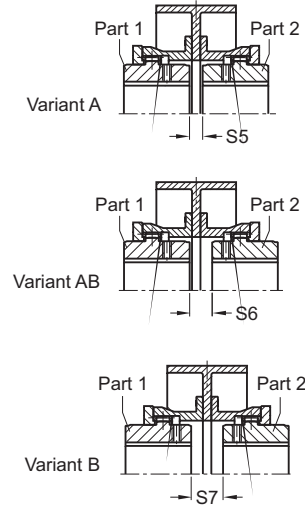
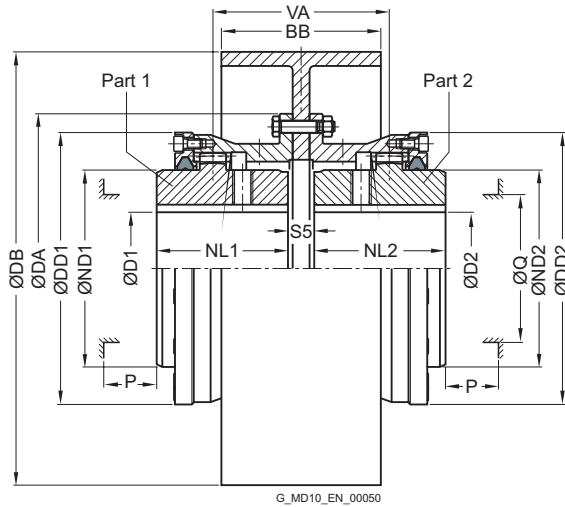

Size	Rated torque T_{KN} Nm	Maximum speed n_{Kmax} rpm	Dimensions in mm													Brake disk		Article no. ¹⁾			Weight m kg
			D1, D2 Keyway DIN 6885-1		DA	ND1/ND2	NL1/NL2	DD1/DD2	S5	S6	S7	VA	Q	P	DB	BB	Type				
			min.	max.													A	B	AB		
128	2500	2500	0	61	157	80	60	128	16	23	30	83	60	45	200	75	2LC0300-1AW	2LC0300-1AX	2LC0300-1BA	12.5	
		16							23	30	83	250			95	2LC0300-1AW					2LC0300-1AX
146	4300	2000	0	72	177	95	75	146	16	23	30	98	75	45	250	95	2LC0300-2AW	2LC0300-2AX	2LC0300-2BA	19	
		18							25	32	100	315			118	2LC0300-2AW					2LC0300-2AX
175	7000	1600	0	85	215	112	90	175	20	26	32	116	85	50	315	118	2LC0300-3AW	2LC0300-3AX	2LC0300-3BA	33	
		22							28	34	118	400			150	2LC0300-3AW					2LC0300-3AX
198	11600	1600	0	100	237	135	100	198	20	31	42	131	110	50	315	118	2LC0300-4AW	2LC0300-4AX	2LC0300-4BA	41	
		22							33	44	133	400			150	2LC0300-4AW					2LC0300-4AX
230	19000	1250	0	120	265	160	110	230	22	34	46	144	135	50	400	150	2LC0300-5AW	2LC0300-5AX	2LC0300-5BA	64	
		23							35	47	145	500			190	2LC0300-5AW					2LC0300-5AX
255	27000	1000	0	140	294	185	125	255	25	40	55	165	160	50	500	190	2LC0300-6AW	2LC0300-6AX	2LC0300-6BA	95	
		28							43	58	168	630			236	2LC0300-6AW					2LC0300-6AX
290	39000	1000	70	160	330	210	140	290	28	48	68	188	180	60	630	236	2LC0300-7AW	2LC0300-7AX	2LC0300-7BA	160	
		28							48	68	188	710			265	2LC0300-7AW					2LC0300-7AX

Configurable variants ¹⁾

- ØD1 Without finished bore
With finished bore
- ØD2 Without finished bore
With finished bore

Notes

- Mass moment of inertia on request.
- Weights apply to maximum bores.
- Q Diameter required for renewing the sealing rings.
P Length required for renewing the sealing rings.

Ordering example

- ZAPEX ZWB coupling, size 146, variant A, brake disk diameter DB = 315 mm, BB = 118 mm
- Part 1: Bore 40H7mm, keyway to DIN 6885-1 P9 and set screw
- Part 2: Bore 45K7 mm, keyway to DIN 6885-1 P9 and set screw

Article no.: 2LC0300-2AW99-0BA0-Z L0W+M1A+M13

¹⁾ To identify complete item numbers specifying the available finish boring options and – if necessary – further order options, please use our configurators on flender.com.

↗ For online configuration on flender.com, click on the item no.

TYPE ZWTR

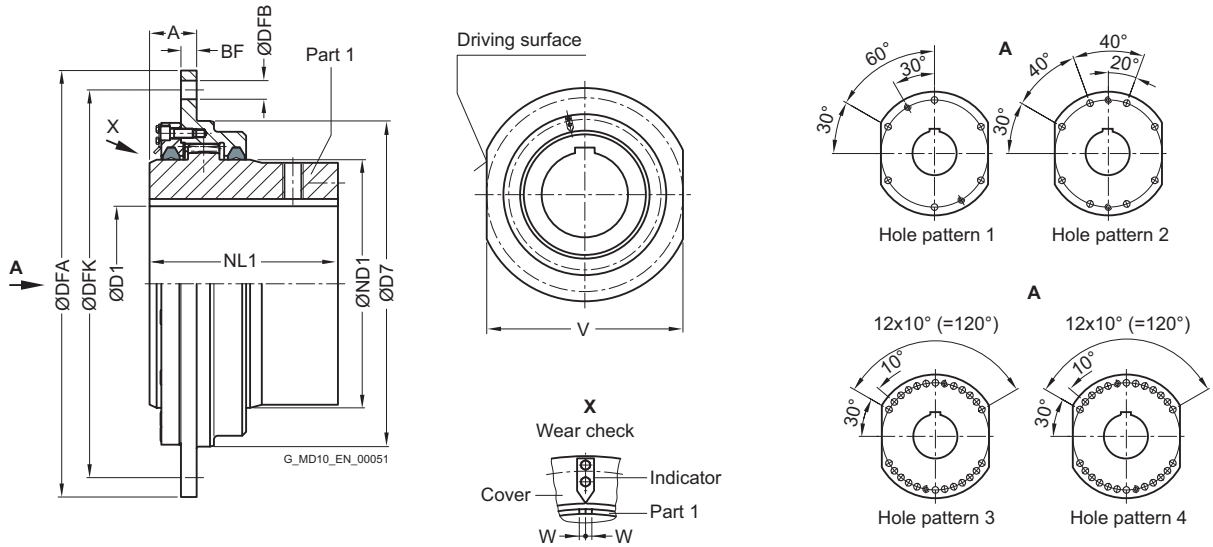

Size	Rated torque T_{KN}	Max. perm. radial load N	Dimensions in mm											Article no. ¹⁾	Weight m kg		
			D1 Keyway DIN 6885-1		ND1	NL1	DFA	D7 h6	V h9	A	BF	DFK	DFB			Hole pattern	Perm. wear W
Nm	N	min.	max.														
198	14500	32500	0	95	135	125	340	220	300	45	15	300	15	1	2	2LC0300-4BN	25
230	17500	36500	0	110	160	130	360	240	320	45	15	320	15	1	2	2LC0300-5BN	30
255	24000	45500	0	125	185	145	380	260	340	45	15	340	19	1	2	2LC0300-6BN	35
290 ²⁾	31500	50000	0	145	210	170	400	280	360	45	15	360	19	1	3	2LC0300-7BN	45
315	42000	70000	0	160	230	175	420	310	380	60	20	380	24	1	3	2LC0300-8BN	60
342 ²⁾	55000	90000	0	180	255	185	450	340	400	60	20	400	24	1	3	2LC0301-0BN	70
375	78000	110000	0	200	290	220	510	400	460	60	20	460	24	1	3	2LC0301-1BN	100
415 ²⁾	104000	150000	0	220	320	240	550	420	500	60	20	500	24	1	3	2LC0301-2BN	130
465 ²⁾	155000	165000	0	250	360	260	580	450	530	60	20	530	24	2	4	2LC0301-3BN	160
505 ²⁾	235000	200000	0	275	400	315	650	530	580	65	25	600	24	2	4	2LC0301-4BN	240
545 ²⁾	390000	325000	0	300	440	350	680	560	600	65	25	630	24	3	4	2LC0301-5BN	320
585 ²⁾	460000	380000	0	330	480	380	710	600	640	81	35	660	28	4	4	2LC0301-6BN	400
640 ²⁾	600000	420000	0	360	520	410	780	670	700	81	35	730	28	4	4	2LC0301-7BN	510
730 ²⁾	880000	500000	0	415	600	450	850	730	760	81	35	800	28	4	5	2LC0302-0BN	690

Configurable variants ¹⁾

- ØD1 Without finished bore
With finished bore

Notes

- Total wear must not exceed 1 x W.
- Mass moment of inertia on request.
- Weights apply to maximum bores.

Ordering example

- ZAPEX ZWTR coupling, size 198, bore 80H7 mm, keyway to DIN 6885-1 P9 and set screw.

Article no.: 2LC0300-4BN90-0AA0-Z L1J

¹⁾ To identify complete item numbers specifying the available finish boring options and – if necessary – further order options, please use our configurators on flender.com.

²⁾ These sizes have connection dimensions according to SEB 666 212.

↗ For online configuration on flender.com, click on the item no.

TYPE ZBR

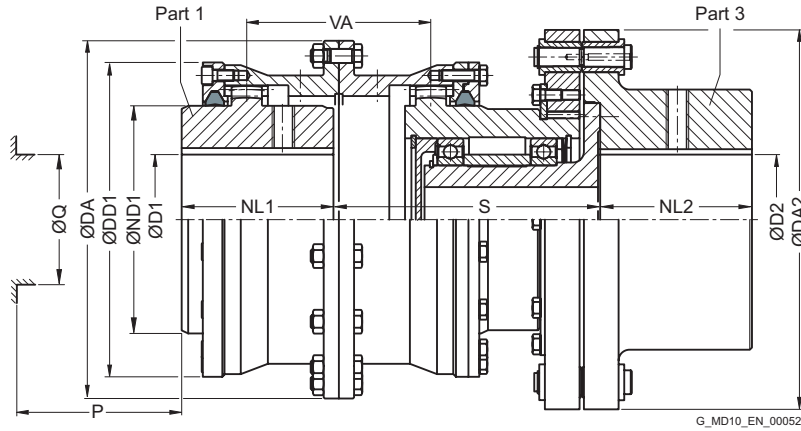

Size	Rated torque T_{KN}	Max. shear torque T_{BR}	Maximum speed n_{Kmax}	Dimensions in mm													Article no. ¹⁾	Weight m
				D1 Keyway DIN 6885-1		D2 Keyway DIN 6885-1		DA	ND1	NL1/ NL2	DA2	DD1	S	VA	Q	P		
	Nm	Nm	rpm	min.	max.	min.	max.											
112	1300	1690	9400	0	49	0	60	143	65	50	170	110	115	56	50	35	2LC0300-0BH	14.5
128	2500	3250	8300	0	61	0	75	157	80	60	190	128	125	73	65	45	2LC0300-1BH	19
146	4300	5590	7300	0	72	0	90	177	95	75	205	146	140	88	75	45	2LC0300-2BH	27.5
175	7000	9100	6400	0	85	0	105	215	112	90	235	175	170	104	85	50	2LC0300-3BH	43
198	11600	15080	5500	0	100	0	120	237	135	100	285	198	185	119	110	50	2LC0300-4BH	67
230	19000	24700	4700	0	120	0	135	265	160	110	300	230	200	130	135	50	2LC0300-5BH	91
255	27000	35100	4100	0	140	0	155	294	185	125	335	255	215	150	160	50	2LC0300-6BH	120
290	39000	50700	3700	70	160	70	185	330	210	140	390	290	240	170	180	60	2LC0300-7BH	170
315	54000	70200	3300	80	175	80	200	366	230	160	415	315	257	190	200	60	2LC0300-8BH	215
342	69000	89700	3000	90	195	90	235	392	255	180	460	340	290	222	225	60	2LC0301-0BH	295
375	98000	127400	2700	100	220	100	240	430	290	200	495	375	300	242	260	60	2LC0301-1BH	380
415	130000	169000	2500	120	240	120	255	478	320	220	540	415	370	294	285	80	2LC0301-2BH	520
465	180000	234000	2200	140	270	140	285	528	360	240	635	465	400	336	325	80	2LC0301-3BH	720
505	250000	325000	2000	160	300	160	320	568	400	260	710	505	420	366	365	80	2LC0301-4BH	970
545	320000	416000	1800	180	330	180	370	620	440	280	800	545	460	406	405	80	2LC0301-5BH	1250
585	400000	520000	1700	210	360	210	390	660	480	310	860	585	500	460	445	80	2LC0301-6BH	1600
640	510000	663000	1600	230	360	230	425	738	480	330	900	640	530	479	445	90	2LC0301-7BH	1850
				>360	390				520					475				
690	660000	858000	1450	250	390	250	450	788	520	350	1020	690	580	516	475	90	2LC0301-8BH	2600
				>390	420				560					515				2650
730	790000	1027000	1350	275	420	275	485	834	560	380	1080	730	620	560	515	90	2LC0302-0BH	3200
				>420	450				600					555				

Configurable variants ¹⁾

- ØD1 Without finished bore
With finished bore
- ØD2 Without finished bore
With finished bore

Notes

- Mass moment of inertia on request.
- Weights apply to maximum bores.
- Q Diameter required for renewing the sealing rings.
P Length required for renewing the sealing rings.

Ordering example

- ZAPEX coupling ZBR, size 146, ultimate moment $T_{break} = 3500$ Nm
- Part 1: Bore 40H7mm, keyway to DIN 6885-1 P9 and set screw
- Part 3: Bore 45K7 mm, keyway to DIN 6885-1 P9 and set screw

Article no.: 2LC0300-2BH99-0BA0-Z L0W+M1A+M13+Y99
Plain text to Y99: $T_{break} = 3500$ Nm

¹⁾ To identify complete item numbers specifying the available finish boring options and – if necessary – further order options, please use our configurators on flender.com.

For online configuration on flender.com, click on the item no.

TYPE ZWS

4

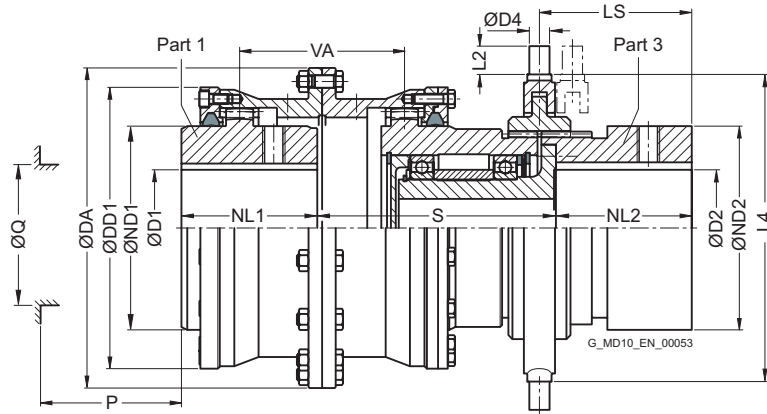

Size	Rated torque T_{KN} Nm	Maximum speed n_{Kmax} rpm	Dimensions in mm																Article no. ¹⁾	Weight m kg		
			D1 Keyway DIN 6885-1		D2 Keyway DIN 6885-1		DA	ND1/ ND2	NL1/ NL2	DD1	S	VA	Q	P	LS	Shift ring		Switch size				
			min.	max.	min.	max.									L4	D4	L2	KSHN	KSZH			
128	2500	1500	0	61	0	50	157	80	60	128	135	73	65	45	70	150	15	14	14/11	-	2LC0300-1BK	16
146	4300	1300	0	72	0	50	177	95	75	146	131	88	75	45	86	180	16	16	16/12	-	2LC0300-2BK	22
175	7000	1100	0	85	0	70	215	112	90	175	165	104	85	50	101	180	16	16	16/12	-	2LC0300-3BK	35
198	11600	960	0	100	0	80	237	135	100	198	182	119	110	50	116	210	20	18	18/13	-	2LC0300-4BK	52
230	19000	830	0	120	0	90	265	160	110	230	198	130	135	50	126	260	22	20	18/15	14/14	2LC0300-5BK	77
255	27000	750	0	140	0	115	294	185	125	255	215	150	160	50	142	300	25	22	21/17	16/17	2LC0300-6BK	98
290	39000	660	70	160	70	130	330	210	140	290	236	170	180	60	157	315	25	35	-	16/211	2LC0300-7BK	140
315	54000	600	80	175	80	140	366	230	160	315	257	190	200	60	182	360	30	24	-	18/18	2LC0300-8BK	200
342	69000	560	90	195	90	160	392	255	180	340	280	222	225	60	202	360	30	24	-	18/18	2LC0301-0BK	230
375	98000	510	100	220	100	180	430	290	200	375	292	242	260	60	222	430	34	26	-	24/20	2LC0301-1BK	340
415	130000	460	120	240	120	210	478	320	220	415	349	294	285	80	247	430	34	26	-	24/20	2LC0301-2BK	430
465	180000	410	140	270	140	230	528	360	240	465	380	336	325	80	267	-	-	-	-	-	2LC0301-3BK	570
505	250000	380	160	300	160	260	568	400	260	505	395	366	365	80	287	-	-	-	-	-	2LC0301-4BK	740
545	320000	350	180	330	180	270	620	440	280	545	460	406	405	80	315	-	-	-	-	-	2LC0301-5BK	1000

Configurable variants ¹⁾

- ØD1 Without finished bore
With finished bore
- ØD2 Without finished bore
With finished bore

Notes

- Mass moment of inertia on request.
- Weights apply to maximum bores.
- Pneumatically or hydraulically actuated switches also available.
- For engaging/disengaging during standstill.
- Part 3 should be mounted on the shaft while the shaft is disconnected and not being driven.
- KSHN Manual lever switch type KSHN to M4218
KSZH Toothed rack type KSZH to M4215

Ordering example

- ZAPEX ZWS coupling, size 146
- Part 1: Bore 40H7mm, keyway to DIN 6885-1 P9 and set screw
- Part 3: Bore 45K7 mm, keyway to DIN 6885-1 P9 and set screw

Article no.: 2LC0300-2BK99-0AA0-Z L0W+M1A+M13

¹⁾ To identify complete item numbers specifying the available finish boring options and – if necessary – further order options, please use our configurators on flender.com.

↗ For online configuration on flender.com, click on the item no.

TYPE ZWNV

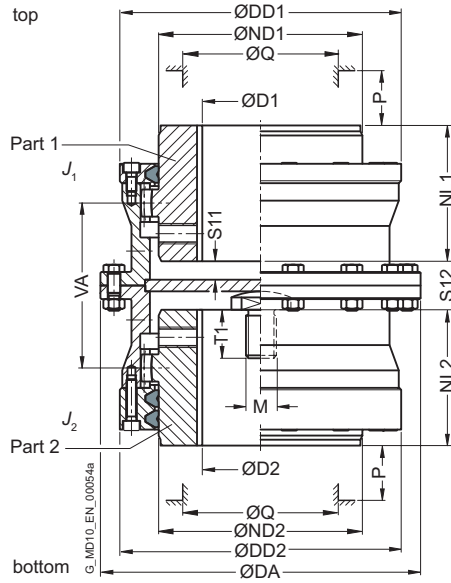

Size	Rated torque T_{KN} Nm	Maximum speed n_{Kmax} rpm	Dimensions in mm											Mass moment of inertia J_1/J_2 kgm ²	Article no. ¹⁾	Weight m kg
			D1, D2 Keyway DIN 6885-1 min. max.	DA	ND1/ ND2	NL1/ NL2	DD1/ DD2	S11	S12	VA	Q	P				
128	2500	8300	0 61	157	80	60	128	6.5	26	73	65	45	0.015	2LC0300-1AH	9.1	
146	4300	7300	0 72	177	95	75	146	6	28	88	75	45	0.023	2LC0300-2AH	13	
175	7000	6400	0 85	215	112	90	175	5.5	33	104	85	50	0.055	2LC0300-3AH	22	
198	11600	5500	0 100	237	135	100	198	10	40	119	110	50	0.095	2LC0300-4AH	31	
230	19000	4700	0 120	265	160	110	230	11	32	130	135	50	0.18	2LC0300-5AH	43	
255	27000	4100	0 140	294	185	125	255	14	40	150	160	50	0.28	2LC0300-6AH	56	
290	39000	3700	70 160	330	210	140	290	19	50	170	180	60	0.55	2LC0300-7AH	81	
315	54000	3300	80 175	366	230	160	315	18	50	190	200	60	0.88	2LC0300-8AH	110	
342	69000	3000	90 195	392	255	180	340	29	72	222	225	60	1.3	2LC0301-0AH	140	
375	98000	2700	100 220	430	290	200	375	29	72	242	260	60	2.1	2LC0301-1AH	185	
415	130000	2500	120 240	478	320	220	415	60	136	294	285	80	3.4	2LC0301-2AH	250	
465	180000	2200	140 270	528	360	240	465	80	176	336	325	80	5.6	2LC0301-3AH	340	
505	250000	2000	160 300	568	400	260	505	89	196	366	365	80	8.2	2LC0301-4AH	420	

Configurable variants ¹⁾

- ØD1 Without finished bore
With finished bore
- ØD2 Without finished bore
With finished bore

Notes

- When ordering, state thread size M and thread length T1 of the thrust piece.
- Mass moments of inertia apply to a coupling half with maximum bore diameter.
- Weights apply to the entire coupling with maximum bores.
- Q Diameter required for renewing the sealing rings.
P Length required for renewing the sealing rings.

Ordering example

- ZAPEX ZWNV coupling, size 146, thread M10 x 20 deep
- Part 1: Bore 40H7mm, keyway to DIN 6885-1 P9 and set screw
- Part 2: Bore 45K7 mm, keyway to DIN 6885-1 P9 and set screw

Article no.: 2LC0300-2AH99-0AA0-Z L0W+M1A+M13+Y99
Plain text to Y99: Thread M10 x 20 mm

¹⁾ To identify complete item numbers specifying the available finish boring options and – if necessary – further order options, please use our configurators on flender.com.

↗ For online configuration on flender.com, click on the item no.

TYPE ZWSE

4

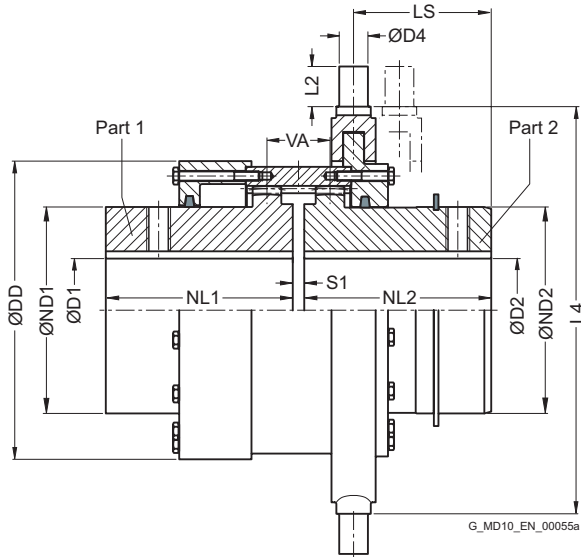

Size	Rated torque T_{KN} Nm	Maximum speed n_{Kmax} rpm	Dimensions in mm															Shift ring	Switch size		Article no. ¹⁾	Weight m kg
			D1 Keyway DIN 6885-1		ND1	ND2	NL1	NL2	DD	S1	VA	LS	L4	D4	L2	KSHN	KSZH					
			min.	max.															min.	max.		
128	2500	730	0	55	0	55	76.5	75	60	60	130	6	30	36.5	180	16	16	16	-	2LC0300-1BM	8.8	
146	4300	630	0	69	0	65	91.5	90	75	75	150	6	33	50	210	20	18	18	-	2LC0300-2BM	13.5	
175	7000	530	0	80	0	75	108	105	90	90	180	8	46	56.5	250	20	30	18	-	2LC0300-3BM	23	
198	11600	470	0	95	0	95	130	130	100	100	204	8	48	64.5	260	22	20	18	-	2LC0300-4BM	32	
230	19000	410	0	115	0	110	155	155	110	110	236	8	50	73	300	25	22	21	-	2LC0300-5BM	44	
255	27000	370	0	135	0	130	180	180	125	125	260	10	55	82	355	25	35	24	-	2LC0300-6BM	63	
290	39000	330	70	155	70	145	210	210	140	140	295	10	38	64.5	355	25	35	24	-	2LC0300-7BM	82	
315	54000	300	80	170	80	165	230	230	160	160	325	10	42	76	355	25	35	24	-	2LC0300-8BM	105	
342	69000	280	90	190	90	175	255	255	180	180	345	12	46	82	430	34	26	-	24	2LC0301-0BM	145	
375	98000	250	100	210	100	200	280	280	200	200	378	12	48	90	430	34	26	-	24	2LC0301-1BM	180	
415	130000	220	120	240	120	225	320	320	220	240	425	12	52	120	580	40	40	-	24	2LC0301-2BM	295	
465	180000	200	140	270	140	250	360	360	240	260	470	16	60	150	580	40	40	-	24	2LC0301-3BM	350	
505	250000	180	160	300	160	270	400	400	260	280	510	16	62	161	-	-	-	-	24	2LC0301-4BM	400	

Configurable variants ¹⁾

- ØD1 Without finished bore
With finished bore
- ØD2 Without finished bore
With finished bore

Notes

- Mass moment of inertia on request.
- Weights apply to maximum bores.
- For engaging/disengaging during standstill.
- Part 2 should be mounted on the shaft while the shaft is disconnected and not being driven.
- Protect sliding surfaces from dirt and corrosion; sprayed with adhesive grease.

Ordering example

- ZAPEX ZWSE coupling, size 146
- Part 1: Bore 40H7mm, keyway to DIN 6885-1 P9 and set screw,
- Part 2: Bore 45K7 mm, keyway to DIN 6885-1 P9 and set screw.

Article no.: 2LC0300-2BM99-0AA0-Z L0W+M1A+M13

¹⁾ To identify complete item numbers specifying the available finish boring options and – if necessary – further order options, please use our configurators on flender.com.

↗ For online configuration on flender.com, click on the item no.

CUSTOMIZED HUB DESIGN

ZAPEX couplings can be provided with customized S-dimensions and hub lengths.

The entire dimension S results from the sum of the individual measurements SF1 and SF2. SF1 and SF2 are the measurements from the interstice of the coupling ring flange up to the beginning of the respective hub. As standard SF1 and SF2 are identical to each other and the entire S-dimension arises in accordance with them.

SF1 and SF2 can be chosen different on customer request, however the minimal and maximum values of the following table have to be observed. Within these limits the measurements SF1 and SF2 may be chosen freely.

The distance VA of the coupling teeth, the permitted bore diameter and the hub diameter remain unchanged.

By stating the hub S-dimension and both hub lengths the coupling is completely described.

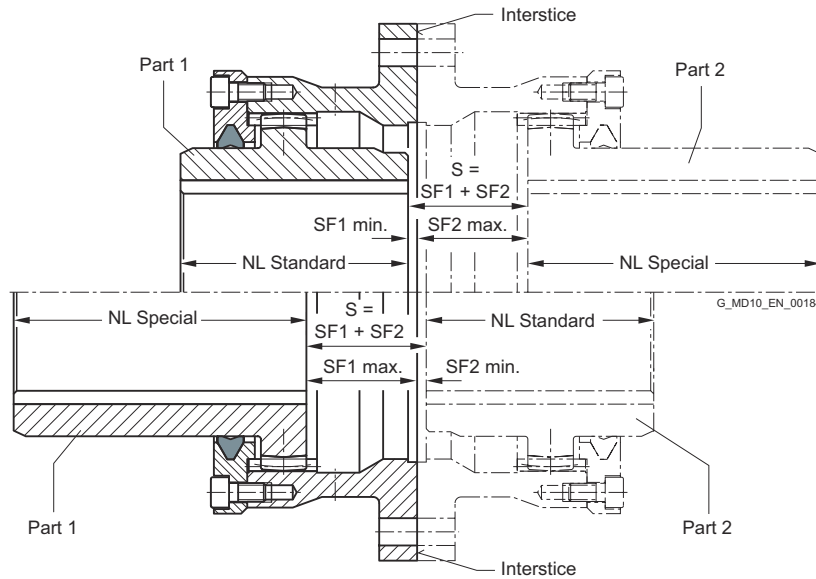

Geometric data			
Size	Standard hub length NL mm	Minimal dimension SF1 or SF2 mm	Maximum dimension SF1 or SF2 mm
112	50	3	23
128	60	3	30.5
146	75	3	36.5
175	90	4	43
198	100	4	49.5
230	110	4	54
255	125	5	62.5
290	140	5	71
315	160	5	79
342	180	6	94
375	200	6	103
415	220	6	127
465	240	8	146
505	260	8	160

The minimal hub lengths are not to fall below the standard hub lengths. If there's no other possibility, for hub lengths smaller than standard hub lengths the order codes "Y50" for part 1 and "Y51" for part 2 must be stated in plain text.

Article number

The Article number of the respective ZAPEX coupling type must be supplemented with "-Z" and order codes for non standard SF-dimensions (order code "Y38" for part 1 and "Y39" for part 2). For no standard hub lengths the order codes "Y40" to "Y49" must be specified (see table Page 4/22).

Ordering example

- ZAPEX coupling ZWN 175, variant A
- Hub left: Bore D1 = 70H7 mm, keyway to DIN 6885-1 P9 and set screw; NL1 = 160 mm; SF1 = 10 mm
- Hub right: Bore D2 = 75H7 mm, keyway to DIN 6885-1 P9 and set screw; NL2 = 100 mm; SF2 = 25 mm

Article no.: 2LC0300-3AA99-0AA0-Z L1G M1H Y38 Y39 Y41 Y46

Plain text to Y38: SF1 = 10 mm

Plain text to Y39: SF2 = 25 mm

Plain text to Y46: NL1 = 160 mm

Plain text to Y41: NL2 = 100 mm

CUSTOMIZED HUB DESIGN

Order code for hub prolongations (Y4). (Std-NL = Standard hub length)

4

Part 1		
Selected (special) hub length min.	max.	Order code (specification of hub length in plain text)
>Std-NL	$\leq 1.25 \cdot \text{Std-NL}$	Y40
>1.25 · Std-NL	$\leq 1.5 \cdot \text{Std-NL}$	Y42
>1.5 · Std-NL	$\leq 1.75 \cdot \text{Std-NL}$	Y44
>1.75 · Std-NL	$\leq 2 \cdot \text{Std-NL}$	Y46
>2 · Std-NL		Y48

Part 2		
Selected (special) hub length min.	max.	Order code (specification of hub length in plain text)
>Std-NL	$\leq 1.25 \cdot \text{Std-NL}$	Y41
>1.25 · Std-NL	$\leq 1.5 \cdot \text{Std-NL}$	Y43
>1.5 · Std-NL	$\leq 1.75 \cdot \text{Std-NL}$	Y45
>1.75 · Std-NL	$\leq 2 \cdot \text{Std-NL}$	Y47
>2 · Std-NL		Y49

SPARE AND WEAR PARTS

DUO sealing rings

The DUO sealing rings are wear parts and must be replaced in accordance with the operating instructions.

Size	Hub diameter ND1/ND2 mm	Article No.
112	65	2LC0300-0XG00-0AA0
128	80	2LC0300-1XG00-0AA0
146	95	2LC0300-2XG00-0AA0
175	112	2LC0300-3XG00-0AA0
198	135	2LC0300-4XG00-0AA0
230	160	2LC0300-5XG00-0AA0
255	185	2LC0300-6XG00-0AA0
290	210	2LC0300-7XG00-0AA0
315	230	2LC0300-8XG00-0AA0
342	255	2LC0301-0XG00-0AA0
375	290	2LC0301-1XG00-0AA0
415	320	2LC0301-2XG00-0AA0
465	360	2LC0301-3XG00-0AA0
505	400	2LC0301-4XG00-0AA0
545	440	2LC0301-5XG00-0AA0
585	480	2LC0301-6XG00-0AA0
640	480	2LC0301-7XG10-0AA0
	520	2LC0301-7XG20-0AA0
690	520	2LC0301-8XG10-0AA0
	560	2LC0301-8XG20-0AA0
730	560	2LC0302-0XG10-0AA0
	600	2LC0302-0XG20-0AA0
780	600	2LC0302-1XG10-0AA0
	650	2LC0302-1XG20-0AA0
852	650	2LC0302-2XG10-0AA0
	710	2LC0302-2XG20-0AA0
910	710	2LC0302-3XG10-0AA0
	750	2LC0302-3XG20-0AA0

Size	Hub diameter ND1/ND2 mm	Article No.
1020	750	2LC0302-4XG10-0AA0
	800	2LC0302-4XG20-0AA0
1080	800	2LC0302-5XG10-0AA0
	860	2LC0302-5XG20-0AA0
1150	860	2LC0302-6XG10-0AA0
	930	2LC0302-6XG20-0AA0
1160	860	2LC0302-7XG10-0AA0
	930	2LC0302-7XG20-0AA0
1240	990	2LC0302-7XG30-0AA0
	930	2LC0302-8XG10-0AA0
1310	990	2LC0302-8XG20-0AA0
	1055	2LC0302-8XG30-0AA0
1380	930	2LC0303-0XG10-0AA0
	990	2LC0303-0XG20-0AA0
1440	1055	2LC0303-0XG30-0AA0
	1120	2LC0303-0XG40-0AA0
1540	990	2LC0303-1XG10-0AA0
	1055	2LC0303-1XG20-0AA0
1540	1120	2LC0303-1XG30-0AA0
	1170	2LC0303-1XG40-0AA0
1540	1120	2LC0303-2XG10-0AA0
	1170	2LC0303-2XG20-0AA0
1540	1240	2LC0303-2XG30-0AA0
	1120	2LC0303-2XG40-0AA0
1540	1170	2LC0303-3XG10-0AA0
	1240	2LC0303-3XG20-0AA0
1540	1310	2LC0303-3XG30-0AA0
	1310	2LC0303-3XG40-0AA0

High-performance grease

Container	Content g	Article No.
Cartridge	300	FFA:00000501027

Sealing compound

Container	Content ml	Article No.
Tube	60	FFA:000001443780

TORSIONALLY RIGID GEAR COUPLINGS

ZAPEX ZN SERIES



General	5/3
Benefits	5/3
Application	5/3
Design and configurations	5/4
Function	5/4
Technical specifications	5/5

Type ZNN	5/6

Type ZNZS	5/7

Type ZNW	5/8

Type ZNBG	5/10

Type ZNNA	5/12

Type ZNZA	5/13

Type ZNNV	5/14

Type ZNN for axial displacement	5/15

Customized hub design	5/16

Type ZN – flange connection dimensions	5/18

Spare and wear parts	5/19



ZAPEX ZN
FLENDER

GENERAL



Coupling suitable for use in potentially explosive atmospheres.

Complies with the current ATEX Directive for:

CE  II 2G Ex h IIC T6 ... T5 Gb X

 II 2D Ex h IIIC T85 °C ... 100 °C Db X

 I M2 Ex h Mb X

Materials

- Hubs and flanged sleeves: Steel
- O ring: Perbunan
- Lubricant: Grease filling

Benefits

ZAPEX gear couplings link machine shafts and compensate for shaft misalignment with weak restorative forces. High transmissible torque combined with compactness and light weight are characteristic of ZAPEX couplings. ZAPEX coupling types are constructed on a modular principle, so application-related solutions can be delivered quickly.

This coupling requires very little maintenance. Regular grease changes at the prescribed intervals prolong the service life of the coupling.

Application

ZAPEX couplings are especially suited for operation in harsh operating conditions, such as drives in the iron smelting or cement industry.

ZAPEX couplings are suitable for reverse operation and horizontal mounting positions and, in the case of type ZNNV, for vertical mounting positions.

GENERAL

Design and configurations

A ZAPEX coupling comprises two hub sections with external teeth which are mounted on the machine shafts. The external teeth engage with a flanged sleeve with corresponding internal teeth. The flanged sleeves are connected via two flanges with close-fitting bolts. The teeth are lubricated with grease. On the ZAPEX type ZN, O-rings are used to seal the tooth space. The O-rings prevent the lubricant from escaping and dirt from entering the tooth space. The parallel keyways must be sealed during assembly to prevent lubricant from escaping. Customized hub designs are described after the types.

Type	Description
ZNN	Standard type
ZNZS	with adapter
ZNW	with intermediate shaft
ZNBG	with straight brake disk
ZNNA	With axial backlash limiter
ZNZA	With adapter and axial backlash limiter
ZNNV	Vertical type
ZNN	For axial displacement

Further application-specific coupling types are available; dimension sheets for and information on these are available on request.

Function

The torque is transmitted through the coupling teeth. The teeth are crowned, so angular displacement per tooth plane is possible. Radial displacement can be compensated for via the space VA between the tooth planes. The internal teeth of the flanged sleeves are significantly wider than the external teeth of the hub parts, permitting a relatively high axial misalignment.

A small angular misalignment on the coupling teeth results in an advantageous distribution of the lubricant film in contact with the teeth and a very low wear rate. This favorable condition can be deliberately set by aligning the drive with the machine shafts with a slight radial misalignment.

Technical specifications

Power ratings						
Size	Rated torque	Maximum torque	Overload torque	Fatigue torque	Torsional stiffness ZN	Permitted axial shaft misalignment ΔK_a mm
	T_{KN} Nm	T_{Kmax} Nm	T_{KOL} Nm	T_{KW} Nm	C_{Tdyn} kNm/rad	
83	1020	2040	4080	408	500	1
107	2210	4420	8840	884	1400	1
130	4020	8040	16080	1600	2500	1
156	6600	13200	26400	2640	5800	1
181	11000	22000	44000	4400	9200	1
211	19200	38400	76800	7680	16600	1
250	30680	61360	122720	12270	27300	1
274	43550	87100	174200	17400	41500	1.5
307	61750	123500	247000	24700	61000	1.5
333	87100	174200	348400	34800	79000	1.5
364	117000	234000	468000	46800	99000	1.5
424	162500	325000	650000	64800	156000	1.5

The specified torsional stiffness "ZN" applies to coupling types ZNN, ZNNA, ZNNV and ZNN for axial displacement. Torsional stiffness of types ZNZS, ZNW, ZNBG and ZNZA on request.

The axial misalignment ΔK_a must be understood as the maximum permitted enlargement of the hub distance S of the coupling.

The axial misalignment ΔK_a does not apply to the types ZNNA, ZNNV, ZNBG and ZNZA.

Angular misalignment ΔK_w

Types ZNN, ZNZS, ZNW, ZNNV, ZNN for axial displacement: $\Delta K_w = 0.5^\circ$
Types ZNBG, ZNNA, ZNZA: $\Delta K_w = 0.2^\circ$

Radial misalignment ΔK_r

Types ZNN, ZNZS, ZNW, ZNNV, ZNN for axial displacement: $\Delta K_r \leq VA \cdot \tan 0.5^\circ$
Types ZNBG, ZNNA, ZNZA: $\Delta K_r \leq VA \cdot \tan 0.2^\circ$
For the tooth distance VA, see the relevant table for the subassembly.

TYPE ZNN

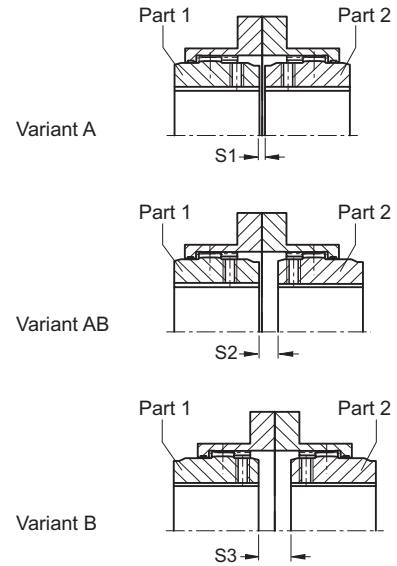
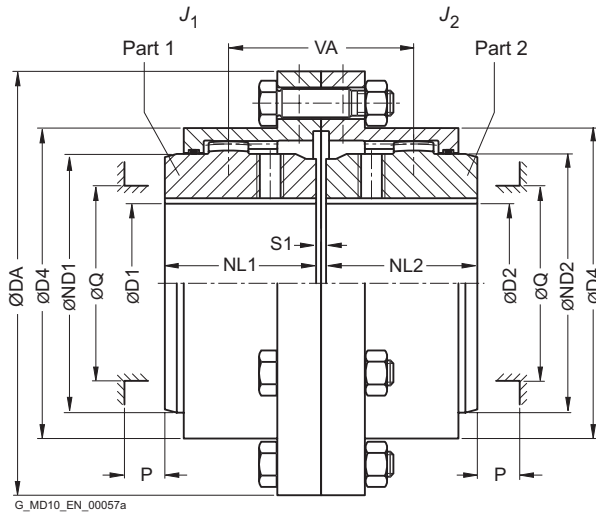

5

Size	Rated torque T_{KN} Nm	Maximum speed n_{Kmax} rpm	Dimensions in mm											Mass moment of inertia J_1/J_2 kgm ²	Article no. ¹⁾			Weight m kg	
			D1, D2 Keyway DIN 6885-1		DA	ND1/ND2	NL1/NL2	D4	S1	S2	S3	VA	Q		P	Type			
			min.	max.												A	B		AB
83	1020	8500	0	50	117	67	43	83	3	12	21	55	52	31	0.003	2LC0330-0AA	2LC0330-0AB	2LC0330-0AC	3.2
107	2210	7700	0	65	152	87	50	107	3	9	15	59	68	34	0.009	2LC0330-1AA	2LC0330-1AB	2LC0330-1AC	6.5
130	4020	6900	0	82	178	108	62	129.5	3	17	31	79	85	42	0.02	2LC0330-2AA	2LC0330-2AB	2LC0330-2AC	9.8
156	6600	6200	0	100	213	130	76	156	5	17	29	93	110	47	0.05	2LC0330-3AA	2LC0330-3AB	2LC0330-3AC	17.5
181	11000	5800	0	116	240	153	90	181	5	19	33	109	130	58	0.09	2LC0330-4AA	2LC0330-4AB	2LC0330-4AC	25.5
211	19200	5100	0	137	280	180	105	211	6	23	40	128	150	67	0.21	2LC0330-5AA	2LC0330-5AB	2LC0330-5AC	43
250	30680	4500	0	164	318	214	120	249.5	6	24	42	144	175	72	0.39	2LC0330-6AA	2LC0330-6AB	2LC0330-6AC	60
274	43550	4000	80	178	347	233	135	274	8	29	50	164	190	81	0.59	2LC0330-7AA	2LC0330-7AB	2LC0330-7AC	82
307	61750	3750	90	198	390	260	150	307	8	32	56	182	220	91	1.1	2LC0330-8AA	2LC0330-8AB	2LC0330-8AC	115
333	87100	3550	100	216	425.5	283	175	332.5	8	39	70	214	250	104	1.8	2LC0331-0AA	2LC0331-0AB	2LC0331-0AC	155
364	117000	3400	120	242	457	312	190	364	8	46	84	236	265	126	2.3	2LC0331-1AA	2LC0331-1AB	2LC0331-1AC	180
424	162500	3200	150	288	527	371	220	423.5	10	43	76	263	300	140	4.9	2LC0331-2AA	2LC0331-2AB	2LC0331-2AC	275

Configurable variants ¹⁾

- ØD1 Without finished bore
With finished bore
- ØD2 Without finished bore
With finished bore

Notes

- Mass moments of inertia apply to a coupling half with maximum bore diameter.
- Weights apply to the entire coupling with maximum bores.
- Q Diameter required for renewing the sealing rings.
P Length required for renewing the sealing rings, aligning the coupling parts and tightening the set screw.

Ordering example

- ZAPEX ZNN coupling, size 107, variant A
- Part 1: Bore 40H7mm, keyway to DIN 6885-1 P9 and set screw
- Part 2: Bore 45K7 mm, keyway to DIN 6885-1 P9 and set screw

Article no.: 2LC0330-1AA99-0AA0-Z L0W+M1A+M13

¹⁾ To identify complete item numbers specifying the available finish boring options and – if necessary – further order options, please use our configurators on flender.com.

➤ For online configuration on flender.com, click on the item no.

TYPE ZNZZ

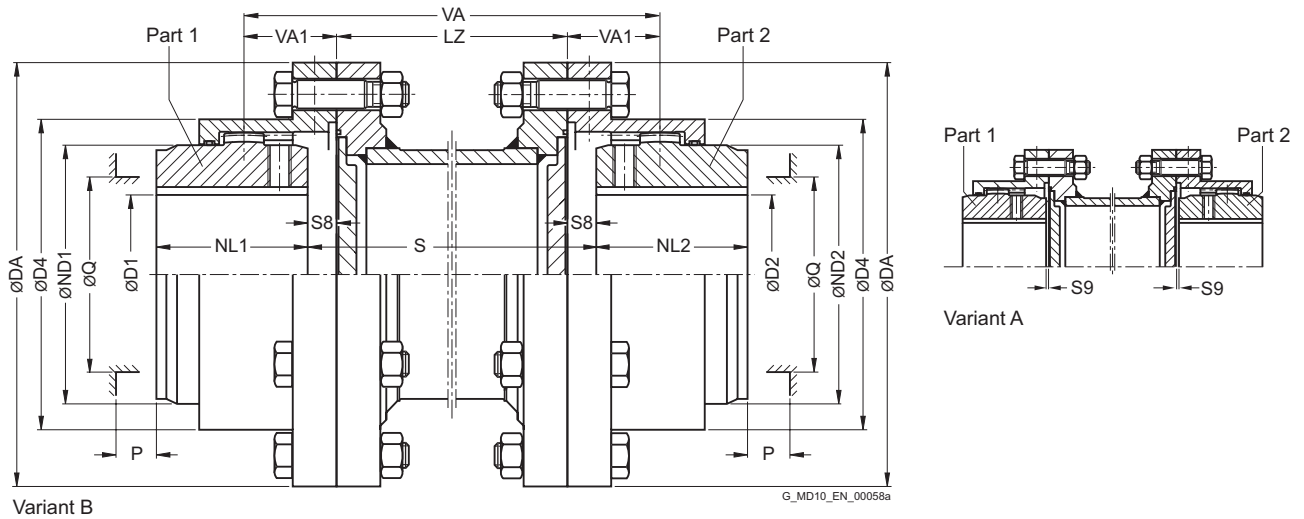

Size	Rated torque T_{KN} Nm	Dimensions in mm												Article no. ¹⁾		Weight each 100 mm pipe	
		D1, D2 Keyway DIN 6885-1 min. max.		DA	ND1/ND2	NL1/NL2	D4	S8	S9	VA1	Q	P	LZ min.	Type A	Type B	kg	m
83	1020	0	50	117	67	43	83	10.5	1.5	27.5	52	31	75	2LC0330-0AD	2LC0330-0AE	0.9	5.5
107	2210	0	65	152	87	50	107	7.5	1.5	29.5	68	34	85	2LC0330-1AD	2LC0330-1AE	0.8	12
130	4020	0	82	178	108	62	129.5	15.5	1.5	39.5	85	42	95	2LC0330-2AD	2LC0330-2AE	1.2	16
156	6600	0	100	213	130	76	156	14.5	2.5	46.5	110	47	110	2LC0330-3AD	2LC0330-3AE	2.3	28
181	11000	0	116	240	153	90	181	16.5	2.5	54.5	130	58	110	2LC0330-4AD	2LC0330-4AE	3.5	40
211	19200	0	137	280	180	105	211	20	3	64	150	67	125	2LC0330-5AD	2LC0330-5AE	4.5	64
250	30680	0	164	318	214	120	249.5	21	3	72	175	72	125	2LC0330-6AD	2LC0330-6AE	6.3	91
274	43550	80	178	347	233	135	274	25	4	82	190	81	125	2LC0330-7AD	2LC0330-7AE	7.2	115
307	61750	90	198	390	260	150	307	28	4	91	220	91	145	2LC0330-8AD	2LC0330-8AE	9.1	175
333	87100	100	216	425.5	283	175	332.5	35	4	107	250	104	145	2LC0331-0AD	2LC0331-0AE	12	220
364	117000	120	242	457	312	190	364	42	4	118	265	126	145	2LC0331-1AD	2LC0331-1AE	15	245
424	162500	150	288	527	371	220	423.5	38	5	131.5	300	140	145	2LC0331-2AD	2LC0331-2AE	16	360

Configurable variants ¹⁾

- ØD1 Without finished bore
With finished bore
- ØD2 Without finished bore
With finished bore

Notes

- $VA = 2 \cdot VA1 + LZ$
- Mass moment of inertia on request.
- Weights apply to the entire coupling with maximum bores and an adapter length of LZ min.
- Maximum speed, limited by weight and critical adapter speed, on request.
- Q Diameter required for renewing the sealing rings.
P Length required for renewing the sealing rings, aligning the coupling parts and tightening the set screw.

Ordering example

- ZAPEX ZNZZ coupling, size 107, variant B, adapter for S = 250 mm
- Part 1: Bore 40H7mm, keyway to DIN 6885-1 P9 and set screw
- Part 2: Bore 45K7 mm, keyway to DIN 6885-1 P9 and set screw

Article no.: 2LC0330-1AE99-0AZ0-Z L0W+M1A+Q0Y+M13
Plain text to Q0Y: 250 mm (dimension S)

¹⁾ To identify complete item numbers specifying the available finish boring options and – if necessary – further order options, please use our configurators on flender.com.

➤ For online configuration on flender.com, click on the item no.

TYPE ZNW

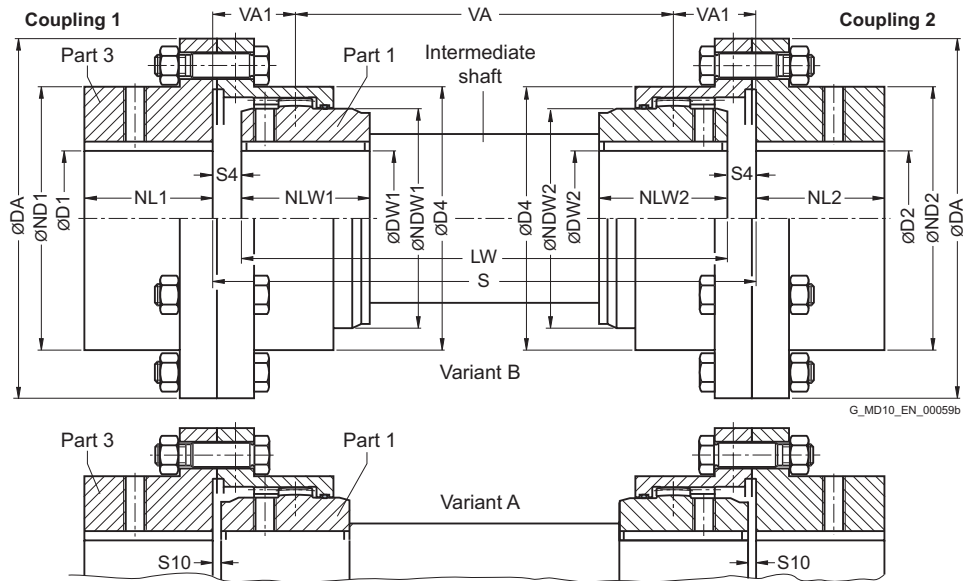

G_MD10_EN_00059b

Size	Rated torque T_{KN} Nm	Dimensions in mm											➤ Article no. ¹⁾		Weight m kg	
		D1, D2 Keyway DIN 6885-1		DA	ND1/ ND2	NL1/NL2/ NLW1/LW2	DW1, DW2 Keyway DIN 6885-1		NDW1/ NDW2	D4	S4	S10	VA1	Type		Type
		min.	max.				min.	max.								
83	1020	0	61	117	83	43	0	50	67	83	12	3	29	2LC0330-0AV	2LC0330-0AW	3.1
107	2210	0	79	152	107	50	0	65	87	107	9	3	31	2LC0330-1AV	2LC0330-1AW	6.2
130	4020	0	96	178	129.5	62	0	82	108	129.5	17	3	41	2LC0330-2AV	2LC0330-2AW	9.5
156	6600	0	116	213	156	76	0	100	130	156	17	5	49	2LC0330-3AV	2LC0330-3AW	17
181	11000	0	134	240	181	90	0	116	153	181	19	5	57	2LC0330-4AV	2LC0330-4AW	24.5
211	19200	0	156	280	211	105	0	137	180	211	23	6	67	2LC0330-5AV	2LC0330-5AW	41
250	30680	0	184	318	249.5	120	0	164	214	249.5	24	6	75	2LC0330-6AV	2LC0330-6AW	58
274	43550	80	202	347	274	135	80	178	233	274	29	8	86	2LC0330-7AV	2LC0330-7AW	76
307	61750	90	228	390	307	150	90	198	260	307	32	8	95	2LC0330-8AV	2LC0330-8AW	110
333	87100	100	247	425.5	332.5	175	100	216	283	332.5	39	8	111	2LC0331-0AV	2LC0331-0AW	150
364	117000	120	270	457	364	190	120	242	312	364	46	8	122	2LC0331-1AV	2LC0331-1AW	170
424	162500	150	313	527	423.5	220	150	288	371	423.5	43	10	136.5	2LC0331-2AV	2LC0331-2AW	270

Configurable variants ¹⁾

- ØD1 Without finished bore
With finished bore
- ØD2 Without finished bore
With finished bore

¹⁾ To identify complete item numbers specifying the available finish boring options and – if necessary – further order options, please use our configurators on flender.com.

➤ For online configuration on flender.com, click on the item no.

Notes

- $VA = S - 2 \cdot VA1$
 - Mass moment of inertia on request.
 - Weights apply to either coupling 1 or 2 with maximum bores, without intermediate shaft.
 - Maximum speed, limited by weight and critical speed of intermediate shaft, on request.
-

Ordering example

- Coupling 1:
ZAPEX ZNW coupling, size 107, variant B,
Part 3: Bore 45K7 mm, keyway to DIN 6885-1 P9
and set screw, Part 1: Bore 45H7 mm,
keyway to DIN 6885-1 P9 and set screw.
-

Article no.: 2LC0330-1AW99-0AA0-Z L1A+L13+M1A

- Intermediate shaft:
Intermediate shaft to ZAPEX ZNW coupling, size 107,
length LW = 570 mm, shaft journal $\varnothing 45p6$ x 50 long;
keyway DIN 6885-1.
-

Article no.: 2LC9310-0XH00-0AA0-Z Y99

Plain text to Y99: DW1 = 45p6 mm, NLW1 = 50 mm,
DW2 = 45p6 mm, NLW2 = 50 mm, LW = 570 mm

- Coupling 2:
ZAPEX ZNW coupling, size 107, variant B,
Part 1: Bore 45H7 mm, keyway to DIN 6885-1 P9
and set screw, Part 3: Bore 45K7 mm,
keyway to DIN 6885-1 P9 and set screw.
-

Article no.: 2LC0330-0AW99-0AA0-Z L1A+M1A+L13

TYPE ZNBG

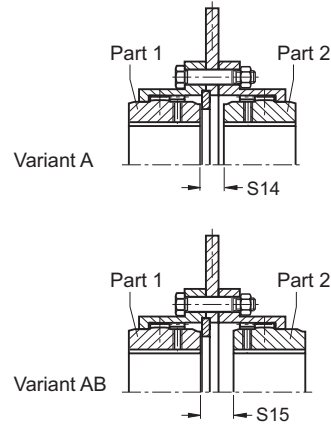
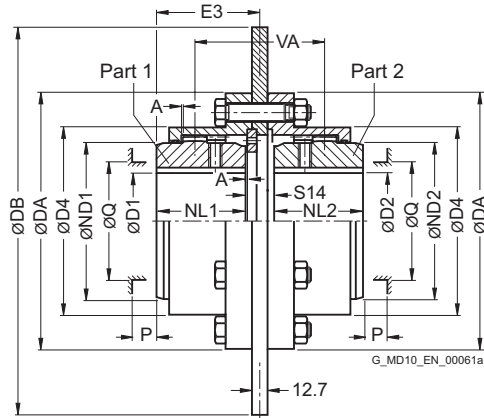

5

Size	Rated torque T_{KN} Nm	Maximum speed n_{Kmax} rpm	Dimensions in mm											Brake disk		Article no. ¹⁾		Weight m kg	
			D1, D2 Keyway DIN 6885-1 min. max.		DA	ND1/ND2	NL1/NL2	D4	S14	S15	A	VA	Q	P	DB	E3	Type		A
83	1020	3800	0	50	117	67	43	83	17	26	0.5	69	52	31	300	52	2LC0330-0AQ	2LC0330-0AR	10
107	2210	3200	0	65	152	87	50	107	20.5	26.5	0.5	76.5	68	34	356	61	2LC0330-1AQ	2LC0330-1AR	16
130	4020	3200	0	82	178	108	62	129.5	20.5	34.5	0.5	96.5	85	42	356	73	2LC0330-2AQ	2LC0330-2AR	16.5
		17.5							31.5	93.5		406			71.5	2LC0330-2AQ	2LC0330-2AR	19.5	
156	6600	2800	0	100	213	130	76	156	20	32	0.5	108	110	47	406	87	2LC0330-3AQ	2LC0330-3AR	29
		23							35	111		457			88.5	2LC0330-3AQ	2LC0330-3AR	33	
181	11000	2800	0	116	240	153	90	181	20	34	0.5	124	130	58	406	101	2LC0330-4AQ	2LC0330-4AR	38
		23							37	127		457			102.5	2LC0330-4AQ	2LC0330-4AR	42	
211	19200	2500	0	137	280	180	105	211	24.5	41.5	0.5	146.5	150	67	514	102.5	2LC0330-4AQ	2LC0330-4AR	46
		24.5							41.5	146.5		457			118.5	2LC0330-5AQ	2LC0330-5AR	58	
250	30680	2200	0	164	318	214	120	249.5	24	42	1	162	175	72	514	133	2LC0330-5AQ	2LC0330-5AR	71
		24							42	162		610			118.5	2LC0330-5AQ	2LC0330-5AR	77	
		1850	0						24	42		162			610	133	2LC0330-6AQ	2LC0330-6AR	87
		1600							27	45		165			711	134.5	2LC0330-6AQ	2LC0330-6AR	97

Configurable variants ¹⁾

- ØD1 Without finished bore
With finished bore
- ØD2 Without finished bore
With finished bore

¹⁾ To identify complete item numbers specifying the available finish boring options and – if necessary – further order options, please use our configurators on flender.com.

↗ For online configuration on flender.com, click on the item no.

Size	Rated torque T_{KN} Nm	Maximum speed n_{Kmax} rpm	Dimensions in mm													Brake disk		Article no. ¹⁾		Weight m kg
			D1, D2 Keyway DIN 6885-1		DA	ND1/ND2	NL1/NL2	D4	S14	S15	A	VA	Q	P	DB	E3	Type			
			min.	max.													A	AB		
274	43550	2200	178	347	233	135	274	26.5	47.5	1	182.5	190	81	514	149.5	2LC0330-7AQ	2LC0330-7AR	97		
		1850						26.5	47.5		182.5			610	149.5	2LC0330-7AQ	2LC0330-7AR	105		
		1600						29.5	50.5		185.5			711	151	2LC0330-7AQ	2LC0330-7AR	115		
		1400						35.5	56.5		191.5			812	154	2LC0330-7AQ	2LC0330-7AR	130		
307	61750	1850	198	390	260	150	307	27	51	1	201	220	91	610	165	2LC0330-8AQ	2LC0330-8AR	140		
		1600						30	54		204			711	166.5	2LC0330-8AQ	2LC0330-8AR	155		
		1400						36	60		210			812	169.5	2LC0330-8AQ	2LC0330-8AR	170		
333	87100	1600	216	425.5	283	175	332.5	30	61	1	236	250	104	711	191.5	2LC0331-0AQ	2LC0331-0AR	190		
		1400						36	67		242			812	194.5	2LC0331-0AQ	2LC0331-0AR	205		
364	117000	1400	120	242	457	312	190	364	36	74	1	264	265	126	812	209.5	2LC0331-1AQ	2LC0331-1AR	235	

Configurable variants ¹⁾

- ØD1 Without finished bore
With finished bore
- ØD2 Without finished bore
With finished bore

Notes

- Mass moment of inertia on request.
- Weights apply to maximum bores.
- Variant limited in displacement and axial movement. Max. displacement 0.2°.
- Q Diameter required for renewing the sealing rings.
P Length required for renewing the sealing rings, aligning the coupling parts and tightening the set screw.

Ordering example

- ZAPEX ZN BG coupling, size 107, variant A, brake disk diameter DB = 356 mm
- Part 1: Bore 40H7mm, keyway to DIN 6885-1 P9 and set screw
- Part 2: Bore 45K7 mm, keyway to DIN 6885-1 P9 and set screw

Article no.: 2LC0330-1AQ99-0AA0-Z L0W+M1A+M13

¹⁾ To identify complete item numbers specifying the available finish boring options and – if necessary – further order options, please use our configurators on flender.com.

↗ For online configuration on flender.com, click on the item no.

TYPE ZNNA

5

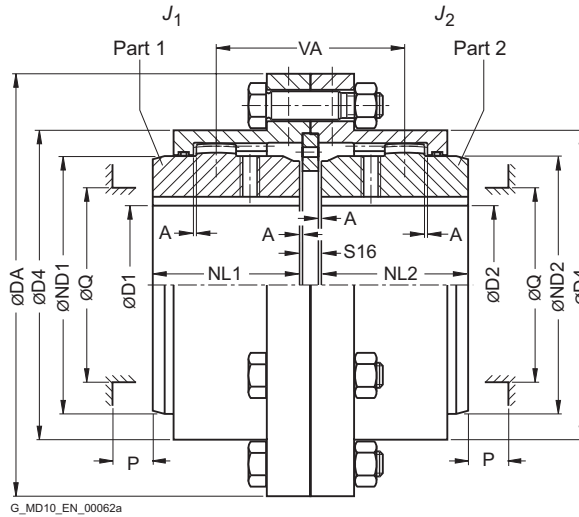

Size	Rated torque T_{KN} Nm	Maximum speed n_{Kmax} rpm	Dimensions in mm											Mass moment of inertia J_1/J_2 kgm ²	Article no. ¹⁾	Weight m kg	
			D1, D2 Keyway DIN 6885-1		DA	ND1/ND2	NL1/NL2	D4	S16	A	VA	Q	P				
			min.	max.													
83	1020	8500	0	50	117	67	43	83	5	0.5	57	52	31	0.003	2LC0330-0AF	3.3	
107	2210	7700	0	65	152	87	50	107	6	0.5	62	68	34	0.01	2LC0330-1AF	6.7	
130	4020	6900	0	82	178	108	62	129.5	6	0.5	82	85	42	0.021	2LC0330-2AF	10.5	
156	6600	6200	0	100	213	130	76	156	9	0.5	97	110	47	0.05	2LC0330-3AF	18	
181	11000	5800	0	116	240	153	90	181	9	0.5	113	130	58	0.095	2LC0330-4AF	26.5	
211	19200	5100	0	137	280	180	105	211	11	0.5	133	150	67	0.22	2LC0330-5AF	44	
250	30680	4500	0	164	318	214	120	249.5	10	1	148	175	72	0.4	2LC0330-6AF	62	
274	43550	4000	80	178	347	233	135	274	13	1	169	190	81	0.64	2LC0330-7AF	82	
307	61750	3750	90	198	390	260	150	307	14	1	188	220	91	1.1	2LC0330-8AF	115	
333	87100	3550	100	216	425.5	283	175	332.5	14	1	220	250	104	1.8	2LC0331-0AF	155	
364	117000	3400	120	242	457	312	190	364	14	1	242	265	126	2.4	2LC0331-1AF	185	
424	162500	3200	150	288	527	371	220	423.5	18	1	271	300	140	4.9	2LC0331-2AF	285	

Configurable variants ¹⁾

- ØD1 Without finished bore
With finished bore
- ØD2 Without finished bore
With finished bore

Ordering example

- ZAPEX ZNNA coupling, size 107
- Part 1: Bore 40H7mm, keyway to DIN 6885-1 P9 and set screw
- Part 2: Bore 45K7 mm, keyway to DIN 6885-1 P9 and set screw

Article no.: 2LC0330-1AF99-0AA0-Z L0W+M1A+M13

Notes

- Mass moments of inertia apply to a coupling half with maximum bore diameter.
- Weights apply to the entire coupling with maximum bores.
- Variant limited in displacement and axial movement. Max. displacement 0.2°.
- Q Diameter required for renewing the sealing rings.
P Length required for renewing the sealing rings, aligning the coupling parts and tightening the set screw.

¹⁾ To identify complete item numbers specifying the available finish boring options and – if necessary – further order options, please use our configurators on flender.com.

↗ For online configuration on flender.com, click on the item no.

TYPE ZNZA

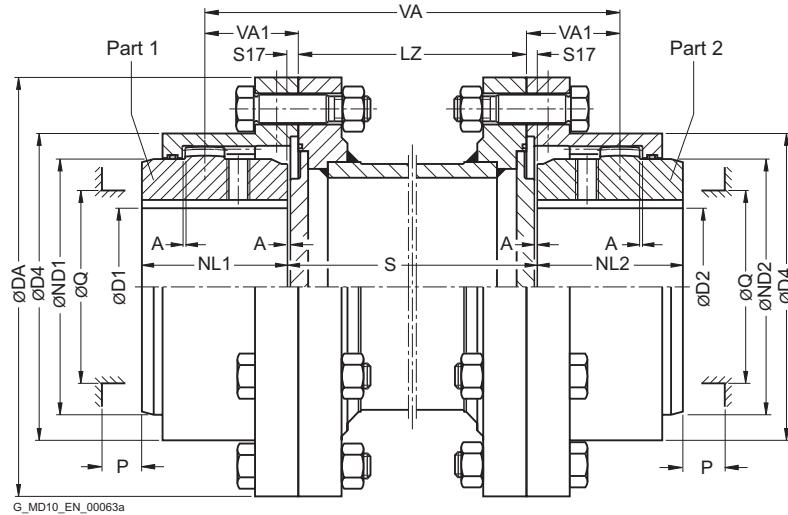

Size	Rated torque T_{KN} Nm	Dimensions in mm											Article no. ¹⁾	Weight each 100 mm pipe		
		D1, D2 Keyway DIN 6885-1		DA	ND1/ND2	NL1/NL2	D4	S17	A	VA1	Q	P		LZ	m	m
		min.	max.										min.	kg	kg	
83	1020	0	50	117	67	43	83	2.5	0.5	28.5	52	31	75	2LC0330-0AG	0.9	5.5
107	2210	0	65	152	87	50	107	3	0.5	31	68	34	85	2LC0330-1AG	0.8	12
130	4020	0	82	178	108	62	129.5	3	0.5	41	85	42	95	2LC0330-2AG	1.2	16
156	6600	0	100	213	130	76	156	4.5	0.5	48.5	110	47	110	2LC0330-3AG	2.3	28
181	11000	0	116	240	153	90	181	4.5	0.5	56.5	130	58	110	2LC0330-4AG	3.5	40
211	19200	0	137	280	180	105	211	5.5	0.5	66.5	150	67	125	2LC0330-5AG	4.5	64
250	30680	0	164	318	214	120	249.5	5	1	74	175	72	125	2LC0330-6AG	6.3	91
274	43550	80	178	347	233	135	274	6.5	1	84.5	190	81	125	2LC0330-7AG	7.2	115
307	61750	90	198	390	260	150	307	7	1	94	220	91	145	2LC0330-8AG	9.1	175
333	87100	100	216	425.5	283	175	332.5	7	1	110	250	104	145	2LC0331-0AG	12	220
364	117000	120	242	457	312	190	364	7	1	121	265	126	145	2LC0331-1AG	15	245
424	162500	150	288	527	371	220	423.5	9	1	135.5	300	140	145	2LC0331-2AG	16	360

Configurable variants¹⁾

- ØD1 Without finished bore
With finished bore
- ØD2 Without finished bore
With finished bore

Notes

- $VA = 2 \cdot VA1 + LZ$
- Mass moment of inertia on request.
- Weights apply to the entire coupling with maximum bores and an adapter length of LZ min.
- Maximum speed, limited by weight and critical adapter speed, on request.
- Q Diameter required for renewing the sealing rings.
P Length required for renewing the sealing rings, aligning the coupling parts and tightening the set screw.

Ordering example

- ZAPEX ZNZA coupling, size 107, adapter for S = 250 mm
- Part 1: Bore 40H7mm, keyway to DIN 6885-1 P9 and set screw
- Part 2: Bore 45K7 mm, keyway to DIN 6885-1 P9 and set screw

Article no.: 2LC0330-1AG99-0AZ0-Z L0W+M1A+Q0Y+M13
Plain text to Q0Y: 250 mm (dimension S)

¹⁾ To identify complete item numbers specifying the available finish boring options and – if necessary – further order options, please use our configurators on flender.com.

➤ For online configuration on flender.com, click on the item no.

TYPE ZNNV

5

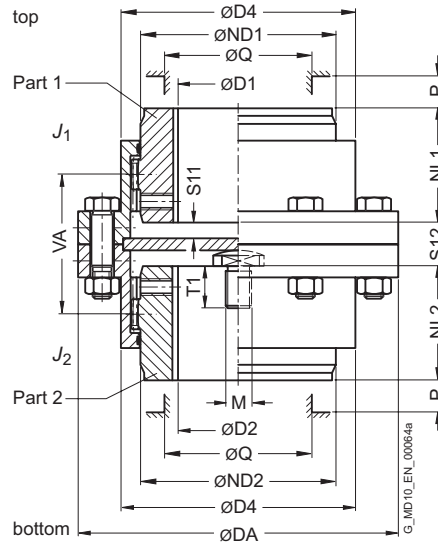

Size	Rated torque T_{KN} Nm	Maximum speed n_{Kmax} rpm	Dimensions in mm											Mass moment of inertia J_1/J_2 kgm ²	Article no. ¹⁾	Weight m kg	
			D1, D2 Keyway DIN 6885-1		DA	ND1/ND2	NL1/NL2	D4	S11	S12	VA1	Q	P				
			min.	max.													
83	1020	8500	0	50	117	67	43	83	8	21	55	52	31	0.003	2LC0330-0AH	3.5	
107	2210	7700	0	65	152	87	50	107	4.5	15	59	68	34	0.009	2LC0330-1AH	6.6	
130	4020	6900	0	82	178	108	62	129.5	12.5	31	79	85	42	0.023	2LC0330-2AH	10.5	
156	6600	6200	0	100	213	130	76	156	10.5	29	93	110	47	0.055	2LC0330-3AH	17	
181	11000	5800	0	116	240	153	90	181	12.5	33	109	130	58	0.1	2LC0330-4AH	25.5	
211	19200	5100	0	137	280	180	105	211	15	40	128	150	67	0.22	2LC0330-5AH	40	
250	30680	4500	0	164	318	214	120	249.5	17	42	144	175	72	0.37	2LC0330-6AH	54	
274	43550	4000	80	178	347	233	135	274	19.5	50	164	190	81	0.64	2LC0330-7AH	87	
307	61750	3750	90	198	390	260	150	307	22	56	182	220	91	1.2	2LC0330-8AH	130	
333	87100	3550	100	216	425.5	283	175	332.5	29	70	214	250	104	1.8	2LC0331-0AH	160	
364	117000	3400	120	242	457	312	190	364	36	84	236	265	126	2.6	2LC0331-1AH	190	
424	162500	3200	150	288	527	371	220	423.5	30	76	263	300	140	5.4	2LC0331-2AH	270	

Configurable variants ¹⁾

- ØD1 Without finished bore
With finished bore
- ØD2 Without finished bore
With finished bore

Notes

- Mass moments of inertia apply to a coupling half with maximum bore diameter.
- Weights apply to the entire coupling with maximum bores.
- When ordering, state thread size M and thread length T1 of the thrust piece.
- Q Diameter required for renewing the sealing rings.
P Length required for renewing the sealing rings, aligning the coupling parts and tightening the set screw.

Ordering example

- ZAPEX ZNNV coupling, size 107
- Part 1: Bore 40H7mm, keyway to DIN 6885-1 P9 and set screw
- Part 2: Bore 45K7 mm, keyway to DIN 6885-1 P9 and set screw, thread M10 x 20 deep.

Article no.: 2LC0330-1AH99-0AA0-Z L0W+M1A+M13+Y99
Plain text to Y99: Thread M10 x 20

¹⁾ To identify complete item numbers specifying the available finish boring options and – if necessary – further order options, please use our configurators on flender.com.

↗ For online configuration on flender.com, click on the item no.

TYPE ZNN FOR AXIAL DISPLACEMENT

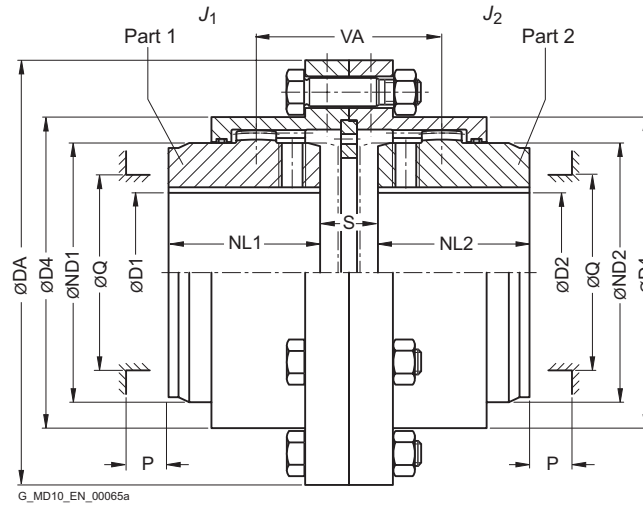

Size	Rated torque T_{KN} Nm	Maximum speed n_{Kmax} rpm	Dimensions in mm											Mass moment of inertia J_1/J_2 kgm ²	Article no. ¹⁾	Weight m kg
			D1, D2 Keyway DIN 6885-1		DA	ND1/ND2	NL1/NL2	D4	S		VA	Q	P			
			min.	max.					min.	max.						
83	1020	8500	0	50	117	67	43	83	6	21	55	52	31	0.003	2LC0330-0AY	3.3
107	2210	7700	0	65	152	87	50	107	7	15	59	68	34	0.01	2LC0330-1AY	6.7
130	4020	6900	0	82	178	108	62	129.5	16	31	79	85	42	0.021	2LC0330-2AY	10.5
156	6600	6200	0	100	213	130	76	156	11	29	93	110	47	0.05	2LC0330-3AY	18
181	11000	5800	0	116	240	153	90	181	11	33	109	130	58	0.095	2LC0330-4AY	26.5
211	19200	5100	0	137	280	180	105	211	14	40	128	150	67	0.22	2LC0330-5AY	44
250	30680	4500	0	164	318	214	120	249.5	12	42	144	175	72	0.4	2LC0330-6AY	62
274	43550	4000	80	178	347	233	135	274	16	50	164	190	81	0.64	2LC0330-7AY	82
307	61750	3750	90	198	390	260	150	307	17	56	182	220	91	1.1	2LC0330-8AY	115
333	87100	3550	100	216	425.5	283	175	332.5	17	70	214	250	104	1.8	2LC0331-0AY	155
364	117000	3400	120	242	457	312	190	364	17	84	236	265	126	2.4	2LC0331-1AY	185
424	162500	3200	150	288	527	371	220	423.5	23	76	263	300	140	4.9	2LC0331-2AY	285

Configurable variants¹⁾

- ØD1 Without finished bore
With finished bore
- ØD2 Without finished bore
With finished bore

Notes

- VA Valid at S max.
- Mass moments of inertia apply to a coupling half with maximum bore diameter.
- Weights apply to the entire coupling with maximum bores.
- Q Diameter required for renewing the sealing rings.
P Length required for renewing the sealing rings, aligning the coupling parts and tightening the set screw.

Ordering example

- ZAPEX ZNN coupling for axial displacement, size 107, S min. = 7 mm, S max. = 15 mm
- Part 1: Bore 40H7mm, keyway to DIN 6885-1 P9 and set screw
- Part 2: Bore 45K7 mm, keyway to DIN 6885-1 P9 and set screw

Article no.: 2LC0330-0AY99-0AA0-Z L0W+M1A+M13

¹⁾ To identify complete item numbers specifying the available finish boring options and – if necessary – further order options, please use our configurators on flender.com.

➤ For online configuration on flender.com, click on the item no.

CUSTOMIZED HUB DESIGN

ZAPEX couplings can be provided with customized S-dimensions and hub lengths.

The entire dimension S results from the sum of the individual measurements SF1 and SF2. SF1 and SF2 are the measurements from the interstice of the coupling ring flange up to the beginning of the respective hub. As standard SF1 and SF2 are identical to each other and the entire S-dimension arises in accordance with them.

SF1 and SF2 can be chosen different on customer request, however the minimal and maximum values of the following table have to be observed. Within these limits the measurements SF1 and SF2 may be chosen freely.

The distance VA of the coupling teeth, the permitted bore diameter and the hub diameter remain unchanged.

By stating the hub S-dimension and both hub lengths the coupling is completely described.

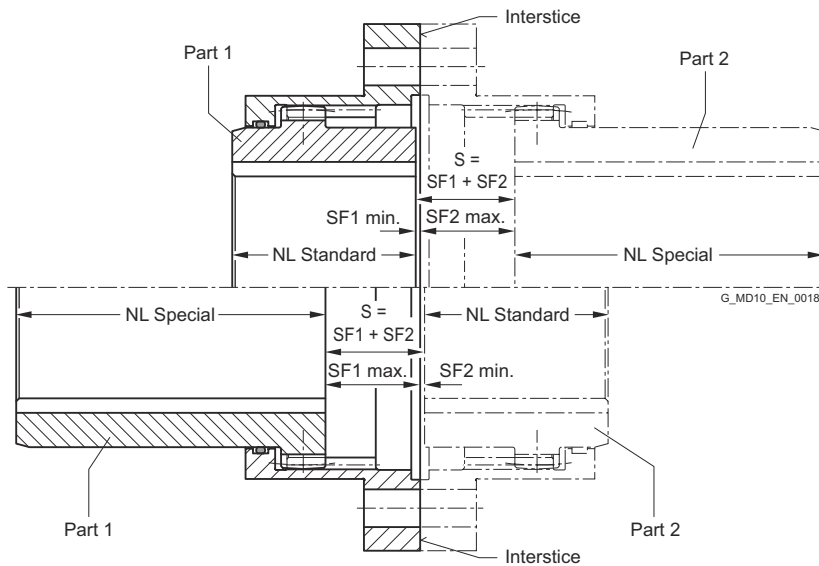

Geometric data			
Size	Standard hub length	Minimal dimension SF1 or SF2 mm	Maximum dimension SF1 or SF2 mm
	NL mm		
83	43	1.5	22
107	50	1.5	23.5
130	62	1.5	32
156	76	2.5	36.5
181	90	2.5	43.5
211	105	3	51
250	120	3	59
274	135	4	64.5
307	150	4	72
333	175	4	85
364	190	4	92
424	220	5	100

The minimal hub lengths are not to fall below the standard hub lengths. If there's no other possibility, for hub lengths smaller than standard hub lengths the order codes "Y50" for part 1 and "Y51" for part 2 must be stated in plain text.

Article number

The Article number of the respective ZAPEX coupling type must be supplemented with "-Z" and order codes for non standard SF-dimensions (order code "Y38" for part 1 and "Y39" for part 2). For no standard hub lengths the order codes "Y40" to "Y49" must be specified (see Page 5/17).

Ordering example

- ZAPEX coupling ZNN 130, variant A
- Hub left: Bore D1 = 70H7 mm, keyway to DIN 6885-1 P9 and set screw; NL1 = 110 mm; SF1 = 10 mm
- Hub right: Bore D2 = 75H7 mm, keyway to DIN 6885-1 P9 and set screw; NL2 = 75 mm; SF2 = 25 mm

Article no.: 2LC0330-2AA99-0AA0-Z L1G M1H Y38 Y39 Y41 Y46

Plain text to Y38: SF1 = 10 mm

Plain text to Y39: SF2 = 25 mm

Plain text to Y46: NL1 = 110 mm

Plain text to Y41: NL2 = 75 mm

Order code for hub prolongations Y4. (Std-NL = Standard hub length)

Part 1		
Selected (special) hub length min.	max.	Order code (specification of hub length in plain text)
>Std-NL	$\leq 1.25 \cdot \text{Std-NL}$	Y40
>1.25 · Std-NL	$\leq 1.5 \cdot \text{Std-NL}$	Y42
>1.5 · Std-NL	$\leq 1.75 \cdot \text{Std-NL}$	Y44
>1.75 · Std-NL	$\leq 2 \cdot \text{Std-NL}$	Y46
>2 · Std-NL		Y48

Part 2		
Selected (special) hub length min.	max.	Order code (specification of hub length in plain text)
>Std-NL	$\leq 1.25 \cdot \text{Std-NL}$	Y41
>1.25 · Std-NL	$\leq 1.5 \cdot \text{Std-NL}$	Y43
>1.5 · Std-NL	$\leq 1.75 \cdot \text{Std-NL}$	Y45
>1.75 · Std-NL	$\leq 2 \cdot \text{Std-NL}$	Y47
>2 · Std-NL		Y49

TYPE ZN – FLANGE CONNECTION DIMENSIONS

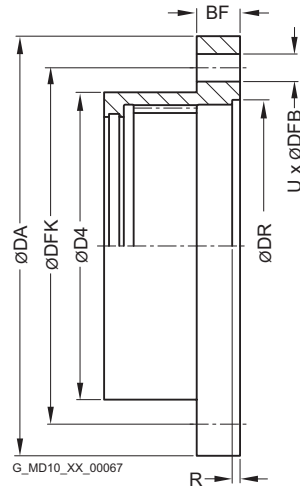

Size	Dimensions in mm							
	DA	BF	D4	DFK	DFB	U Number	DR	R
83	117	14	83	100	9	6	82	2.5
107	152	19	107	131	11	6	105	3
130	178	19	129.5	157	11	8	130	3
156	213	22	156	188	13	6	153	4
181	240	22	181	213	13	10	178	4
211	280	28.5	211	249	17	8	205	5
250	318	28.5	249.5	287	17	10	243	4
274	347	28.5	274	315	17	12	265	5.5
307	390	38	307	352	21	12	302	6
333	425.5	38	332.5	385	21	14	320	6
364	457	26	364	416	21	16	353	6
424	527	28.5	423.5	482	25	16	412	8

SPARE AND WEAR PARTS

Sealing rings

The sealing rings are wear parts and must be replaced in accordance with the operating instructions.

Size	Hub diameter ND1/ND2 mm	Article No.
83	67	2LC0330-0XE00-0AA0
107	87	2LC0330-1XE00-0AA0
130	108	2LC0330-2XE00-0AA0
156	130	2LC0330-3XE00-0AA0
181	153	2LC0330-4XE00-0AA0
211	180	2LC0330-5XE00-0AA0
250	214	2LC0330-6XE00-0AA0
274	233	2LC0330-7XE00-0AA0
307	260	2LC0330-8XE00-0AA0
333	283	2LC0331-0XE00-0AA0
364	312	2LC0331-1XE00-0AA0
424	371	2LC0331-2XE00-0AA0

5

High-performance grease

Container	Content g	Article No.
Cartridge	300	FFA:000000501027

Sealing compound

Container	Content ml	Article No.
Tube	60	FFA:000001443780

TORSIONALLY RIGID ALL-STEEL COUPLINGS N-ARPEX AND ARPEX SERIES



Series N-ARPEX ARN-6/-8/-10	6/3
General	6/3
Benefits	6/3
Application	6/4
Design and configurations	6/5
Technical specifications	6/8
Available standard dimensions for the shaft spacing S	6/10
Type NEN/NHN	6/12
TYPE MCECM/MCHCM	6/14
TYPE MFEFM/MFHFM	6/16
TYPE BEB	6/18
Further hubs	6/19
Further spacers	6/22
Spare and wear parts	6/25
Length-dependent specifications	6/26
Other design options	6/30

Series ARPEX ARW-4/-6	6/31
General	6/31
Benefits	6/31
Application	6/31
Design and configurations	6/32
Technical specifications	6/33
Type NHN	6/35
Spare and wear parts	6/37

Series ARPEX ARF-6	6/38
General	6/38
Benefits	6/38
Application	6/38
Design and configurations	6/39
Technical specifications	6/40
Types GG and GJ	6/41
Spare and wear parts	6/43



N-ARPEX

FLENDER

GENERAL



Coupling suitable for use in potentially explosive atmospheres.

Complies with the current ATEX Directive for:

CE  II 2G Ex h IIC T6 ... T2 Gb X

 II 2D Ex h IIIC T85 °C ... 250 °C Db X

 I M2 Ex h Mb X

Benefits

N-ARPEX couplings of the ARN-6/-8/-10 series are outstanding for their application-optimized construction. The NEN, BEB, MCECM, MFEFM series meet the requirement of **API 610**. Coupling type in accordance with **API 671** is also possible. For speeds of over 1,800 rpm the five-part version with pre-assembled intermediate unit is used.

A special catching device acts to secure the intermediate spacer in the event of plate breakage. Application of the N-ARPEX couplings in potentially explosive atmospheres in accordance with the current ATEX Directive is permitted.

GENERAL

Application

N-ARPEX couplings of the ARN-6/-8/-10 series are used wherever reliable torque transmission is called for, even in cases of often unavoidable shaft misalignment. They are universally applicable over a temperature range of from -50 °C (or even as low as -60 °C on request) up to +280 °C, are torsionally rigid, free of torsional backlash and enable quiet running at a constant angular velocity. They are wear-free and maintenance-free and, if correctly fitted, can be expected to have an unlimited service life.

Especial consideration is given to use in pump and compressor drives. Available for this are couplings with standardised intermediate spacer lengths from stock (see following tables).

By the launch of the new FLENDER N-ARPEX all-steel multiple-disk couplings Flender is continuing the success story of the proven ARPEX coupling series.

An optimised plate pack and a reworked component part design enable even higher torques and speeds to be transmitted.

In short, the new design of the plate packs, the closed flange geometry, the standard catching device of the intermediate spacer and FEM-optimised force distribution inside the all-steel multiple-disk coupling clearly show that the development has paid off.

Main areas of application for the ARN-6/-8/-10 series:

- Pumps
- Fans
- Compressors
- Generator and turbine drives
- Axial and radial blowers
- Paper-making machines and printing machines
- Mixers, Stirrers
- Extruders
- Lifting and traversing gears
- Marine drive
- Water screw drives



Design and configurations

NEN

The design of an N-ARPEX type NEN is shown in the following illustration. The coupling comprises two hubs, an intermediate spacer and two plate packs that in the ARN-6 series are bolted together alternately with close-fitting bolts and in the ARN-8/10 series by means of a Flender conical screw connection. The coupling is available in fixed lengths from stock. Other spacer lengths are manufactured to order. Hubs are designed with threaded pull-off holes.

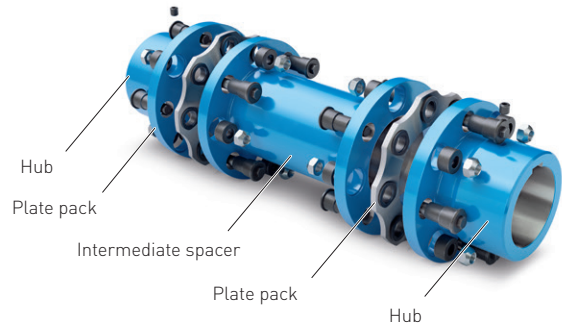

MCECM

The design of an N-ARPEX type MCECM is shown in the following illustration. The coupling comprises two hubs and a pre-assembled intermediate unit (CEC), where the plate packs are bolted together with an intermediate spacer and intermediate flanges at the factory. All that need be done at the construction site is to bolt the hubs with the intermediate flanges. The coupling is available in fixed lengths from stock. Other spacer lengths are manufactured to order. Hubs are designed with threaded pull-off holes.

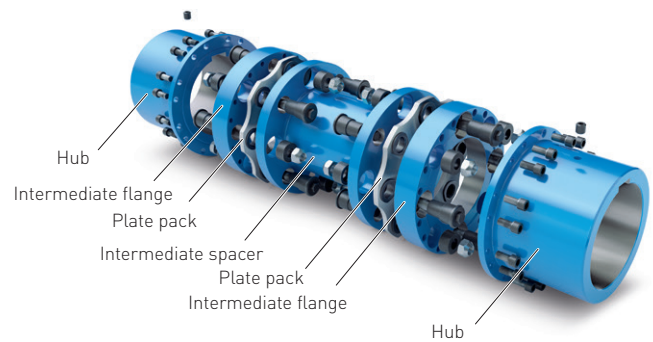

MFEFM

The following illustration shows the N-ARPEX type MFEFM. It most differs from the type MCECM by the considerably increased bore capacity, for which reason this type is intended precisely for comparatively large shaft diameters. The coupling is available in fixed lengths from stock. Other spacer lengths are manufactured to order. Hubs are designed with threaded pull-off holes.

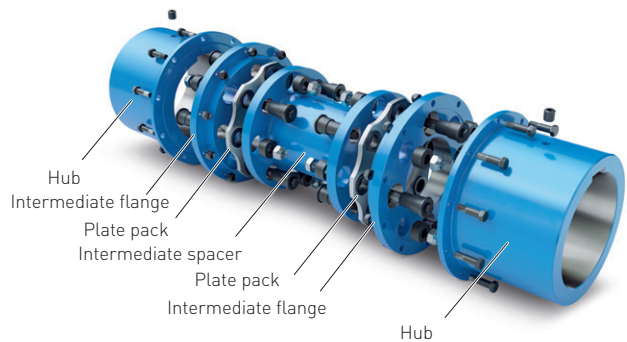

GENERAL

Variants of the N-ARPEX coupling, ARN-6/-8/-10 series

Type	Series			Description
	ARN-6	ARN-8	ARN-10	
NEN	■	■	■	Variant with intermediate spacer machined on all sides, length variable
BEB	■	-	-	Variant with intermediate spacer machined on all sides
MCECM	■	■	-	Variant with preassembled intermediate unit and intermediate spacer machined on all sides, length variable
MFEFM	■	■	■	
NHN	■	■	■	Version with variable spacer tube – specially for greater shaft distances (up to 6,500 mm)
MCHCM	■	■	-	Version with pre-assembled intermediate unit and with variable spacer tube – specially for greater shaft distances (up to 6,500 mm)
MFHFM	■	■	■	

The coupling parts of the N-ARPEX ARN-6/-8/-10 series with the exception of the H spacers have been machined on all sides. The H spacers are delivered with unmachined, primed spacer tube.

Dimension sheets and 3D models of the standard types as well as application-related coupling types are available from the DTK selection module at [flender.com](https://www.flender.com).

Plate-pack designs

The plate packs of the N-ARPEX ARN series are designed with hexagon, octagon and decagon plates, depending on the coupling size. The number of screw connections is indicated in the denomination of the ARN-6/-8/-10 series. Hexagon plates have 6 bolting points, octagon plates have 8 bolting points and decagon plates have 10 bolting points.

The hexagon plates, octagon plates and decagon plates up to size 631 are designed as ring plates. Sizes 694 to 988 are designed as segmented plates.

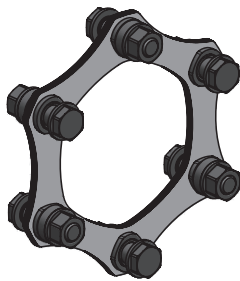

Size 86-6 to 343-6
(hexagon plates)

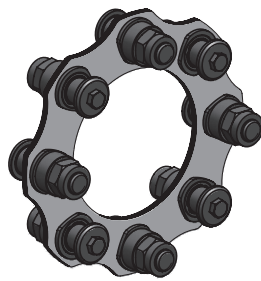

Size 219-8 to 631-8
(octagon plates)

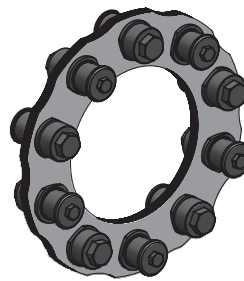

Size 495-10 to 631-10
(decagon plates)

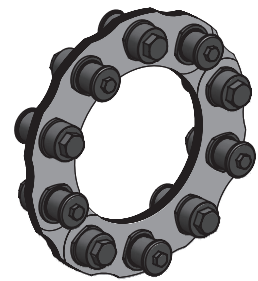

Size 694-10 to 988-10
(decagon plates/segment)

Plate pack screw connection

In the ARN-6 series the plate pack screw connection on N-ARPEX couplings is designed in the form of a close-fitting screw connection. In the ARN-8 and ARN-10 series a conical bolt connection by Flender is used.

The advantage of this screw connection is the considerably simplified installation in the case of large screw connections.

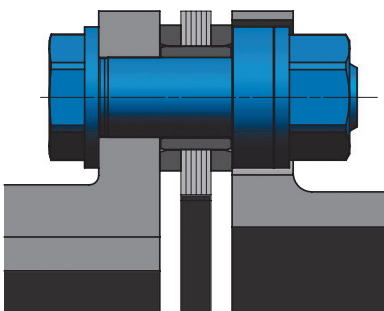

Screw connection / ARN-6 series
Size 86-6 – 343-6

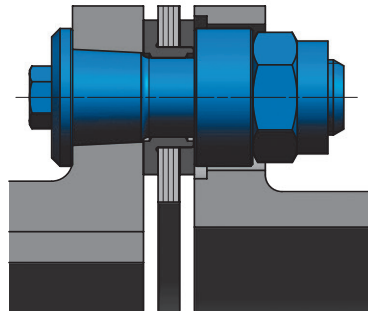

Screw connection / ARN-8 series
Size 219-8 to 354-8

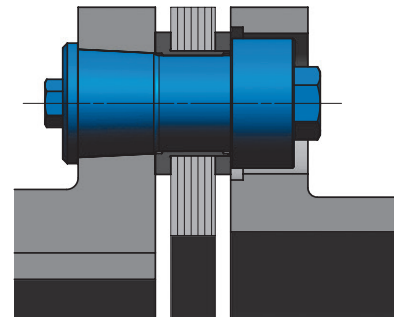

Screw connection / ARN-8 /-10 series
Size 387-8 to 631-8 / Size 495-10 to 988-10

GENERAL

Technical specifications

Power ratings, NEN/NHN, BEB, MCECM/MCHCM and MFEFM/MFHFM series														
Size	Type	Rated torque	Maximum torque	Overload torque	Fatigue torque				Maximum speed	Maximum permitted shaft misalignment (The permissible radial misalignment ΔK_r depends on the total length of the coupling)		Torsional stiffness for a plate pack C_{Tdyn}		
					T_{KN}	T_{Kmax}	T_{KOL}	T_{Kw0}		$T_{KN} = 0\%T_{KN}$	$T_{Kw} = T_{Kw0} \cdot (1 - T_N/T_{KN})$		$25\%T_{KN}$	$50\%T_{KN}$
DA		kNm	kNm	kNm	kNm	kNm	kNm	kNm	kNm	rpm	mm	mm	MNm/rad	
mm														
86-6	6-Bolt	0.35	0.7	0.875	0.175	0.131	0.088	0.044	24000	1.2	1.0 °	0.132		
103-6		0.5	1	1.25	0.25	0.188	0.125	0.063	20000	1.4		0.206		
122-6		0.95	1.9	2.375	0.475	0.356	0.238	0.119	17000	2		0.463		
133-6		1.25	2.5	3.125	0.625	0.469	0.313	0.156	15000	2.2		0.608		
159-6		2.1	4.2	5.25	1.05	0.788	0.525	0.263	13000	2.6		0.986		
174-6		2.5	5	6.25	1.25	0.938	0.625	0.313	12000	3		1.19		
184-6		3.8	7.6	9.5	1.9	1.425	0.95	0.475	11000	3.2		1.83		
203-6		5	10	12.5	2.5	1.875	1.25	0.625	10000	3.4		2.59		
217-6		6.2	12.4	15.5	3.1	2.325	1.55	0.775	9500	3.4		3.28		
251-6		10.5	21	26.25	5.25	3.938	2.625	1.313	8000	4.1		4.71		
268-6		13.8	27.6	34.5	6.9	5.175	3.45	1.725	7500	4.2		5.63		
291-6		18.2	36.4	45.5	9.1	6.825	4.55	2.275	7000	4.6		8.27		
318-6		23	46	57.5	11.5	8.625	5.75	2.875	6500	5		10.94		
343-6		28	56	70	14	10.5	7	3.5	6000	5.3		12.15		
219-8		8-Bolt	10	20	25	5	3.75	2.5	1.25	9500		1.7	0.4 °	6.31
241-8			15	30	37	7.5	5.625	3.75	1.875	8700		1.9		7.64
262-8	20		40	50	10	7.5	5	2.5	8000	2.1	9.09			
285-8	27		54	67	13.5	10.125	6.75	3.375	7300	2.2	11.9			
302-8	35		70	87	17.5	13.125	8.75	4.375	6900	2.4	16.2			
321-8	43		86	107	21.5	16.125	10.75	5.375	6500	2.5	21.9			
354-8	56		112	140	28	21	14	7	5900	3	29.1			
387-8	72		144	180	36	27	18	9	5400	3.3	40			
411-8	93		186	232	46.5	34.875	23.25	11.625	5100	3.4	46.9			
447-8	122		244	305	61	45.75	30.5	15.25	4600	2.5	60.3			
495-8	160		320	400	80	60	40	20	4200	3	76.9			
546-8	212		424	530	106	79.5	53	26.5	3800	3.4	100			
587-8	270		540	675	135	101.25	67.5	33.75	3500	3.6	116			
631-8	350		700	875	175	131.25	87.5	43.75	3300	3.8	138			
495-10	10-Bolt		200	350	450	80	60	40	20	4200	2	0.3 °		150
546-10			270	473	608	108	81	54	27	3800	2.3			194
587-10		352	616	792	140.8	105.6	70.4	35.2	3500	2.4	236			
631-10		450	788	1013	180	135	90	45	3300	2.5	274			
694-10		630	1103	1418	252	189	126	63	3000	2.7	405			
734-10		760	1330	1710	304	228	152	76	2800	2.8	501			
790-10		950	1663	2138	380	285	190	95	2600	3	632			
887-10		1400	2450	3150	560	420	280	140	2300	3.5	858			
988-10		2000	3500	4500	800	600	400	200	2100	3.9	1163			

Notes

- The permitted shaft misalignments ΔK_a , ΔK_r and ΔK_w are maximum values and must not occur at the same time (see table on page 6/9).
- The maximum permissible radial misalignment depends on the shaft distance S. It can be determined for the stated types by using the following formulas:
 NEN/NHN: $\Delta K_r = (S - S1) \cdot \tan(\Delta K_w)$
 BEB, MCECM/ MCHCM and MFEFM/ MFHFM: $\Delta K_r = (LZ + S1) \cdot \tan(\Delta K_w)$
- T_{Kmax} is permitted five times per hour.
- Length-related values like torsional stiffness, total weight and mass moment of inertia are listed in the tables on pages 6/23 to 6/28.
- The torsional stiffness of the plate packs relates to the nominal range of the coupling. For determination of torsional stiffness for a specific operating point outside the nominal range Flender must be consulted.

Permitted shaft misalignments, types NEN/NHN, BEB, MCECM/MCHCM and MFEFM/MFHFM

The permitted shaft misalignments ΔK_a , ΔK_r and ΔK_w are maximum values and must not occur at the same time. The specified axial misalignments apply to the complete coupling. The permissible angular misalignments have been specified per coupling joint. As all N-ARPEX types are designed to be double-jointed, there is a direct interrelation between radial and angular misalignment.

NEN/NHN: $\Delta K_r = (S - S1) \cdot \tan(\Delta K_w)$
 BEB, MCECM/MCHCM and MFEFM/MFHFM: $\Delta K_r = (LZ + S1) \cdot \tan(\Delta K_w)$

To determine the permissible misalignment, values must, if necessary, be converted.

Size DA	Permitted angular misalignment $\pm \Delta K_w$										
	0.0°	0.1°	0.2°	0.3°	0.4°	0.5°	0.6°	0.7°	0.8°	0.9°	1.0°
	Permitted axial misalignment $\pm \Delta K_a$ in mm										
86-6	1.2	1.1	1	0.8	0.7	0.6	0.5	0.4	0.2	0.1	0
103-6	1.4	1.3	1.1	1	0.8	0.7	0.6	0.4	0.3	0.1	0
122-6	2	1.8	1.6	1.4	1.2	1	0.8	0.6	0.4	0.2	0
133-6	2.2	2	1.8	1.5	1.3	1.1	0.9	0.7	0.4	0.2	0
159-6	2.6	2.3	2.1	1.8	1.6	1.3	1	0.8	0.5	0.3	0
174-6	3	2.7	2.4	2.1	1.8	1.5	1.2	0.9	0.6	0.3	0
184-6	3.2	2.9	2.6	2.2	1.9	1.6	1.3	1	0.6	0.3	0
203-6	3.4	3.1	2.7	2.4	2	1.7	1.4	1	0.7	0.3	0
217-6	3.4	3.1	2.7	2.4	2	1.7	1.4	1	0.7	0.3	0
251-6	4.1	3.7	3.3	2.9	2.5	2.1	1.6	1.2	0.8	0.4	0
268-6	4.2	3.8	3.4	2.9	2.5	2.1	1.7	1.3	0.8	0.4	0
291-6	4.6	4.1	3.7	3.2	2.8	2.3	1.8	1.4	0.9	0.5	0
318-6	5	4.5	4	3.5	3	2.5	2	1.5	1	0.5	0
343-6	5.3	4.8	4.2	3.7	3.2	2.7	2.1	1.6	1.1	0.5	0
219-8	1.7	1.28	0.85	0.43	0	-	-	-	-	-	-
241-8	1.9	1.43	0.95	0.48	0	-	-	-	-	-	-
262-8	2.1	1.58	1.05	0.53	0	-	-	-	-	-	-
285-8	2.2	1.65	1.1	0.55	0	-	-	-	-	-	-
302-8	2.4	1.8	1.2	0.6	0	-	-	-	-	-	-
321-8	2.5	1.88	1.25	0.63	0	-	-	-	-	-	-
354-8	3	2.25	1.5	0.75	0	-	-	-	-	-	-
387-8	3.3	2.48	1.65	0.83	0	-	-	-	-	-	-
411-8	3.4	2.55	1.7	0.85	0	-	-	-	-	-	-
447-8	2.5	1.88	1.25	0.63	0	-	-	-	-	-	-
495-8	3	2.25	1.5	0.75	0	-	-	-	-	-	-
546-8	3.4	2.55	1.7	0.85	0	-	-	-	-	-	-
587-8	3.6	2.7	1.8	0.9	0	-	-	-	-	-	-
631-8	3.8	2.85	1.9	0.95	0	-	-	-	-	-	-
495-10	2	1.33	0.67	0	-	-	-	-	-	-	-
546-10	2.3	1.53	0.77	0	-	-	-	-	-	-	-
587-10	2.4	1.6	0.8	0	-	-	-	-	-	-	-
631-10	2.5	1.67	0.83	0	-	-	-	-	-	-	-
694-10	2.7	1.35	0	-	-	-	-	-	-	-	-
734-10	2.8	1.4	0	-	-	-	-	-	-	-	-
790-10	3	1.5	0	-	-	-	-	-	-	-	-
887-10	3.5	1.75	0	-	-	-	-	-	-	-	-
988-10	3.9	1.95	0	-	-	-	-	-	-	-	-

GENERAL

Available standard dimensions for the shaft spacing S

6

Type NEN/NHN														
Size DA mm	Shaft distance S		Preferred dimension V NEN											
	NEN min. mm	NHN min. mm		100	140	180	200	250	300	{88.9} 3.5"	{127} 5"	{177.8} 7"	{228.6} 9"	-
86-6	53	300	100	■										
103-6	54	300	100	■										
122-6	65	300	100	■										
133-6	65	300	100	■										
159-6	80	300	100	■										
174-6	80	300	100	■										
184-6	95	350	140		■									
203-6	100	350	140		■									
217-6	105	350	140		■									
251-6	130	350	180			■								
268-6	140	350	180			■								
291-6	140	350	180			■								
318-6	150	400	200				■							
343-6	150	400	200				■							
219-8	129	350	140		■									
241-8	135	350	140		■									
262-8	145	350	180			■								
285-8	162	350	180			■								
302-8	179	350	180			■								
321-8	196	400	200				■							
354-8	214	400	250					■						
387-8	246	400	250					■						
411-8	256	400	300						■					
447-8	270	400	300						■					
495-8	281	600	300						■					
546-8	299	600	300						■					
587-8	315	600	320										■	
631-8	334	600	340										■	
495-10	281	600	300						■					
546-10	299	600	300						■					
587-10	315	600	320										■	
631-10	334	600	340										■	
694-10	400	600	400										■	
734-10	436	600	440										■	
790-10	466	750	470										■	
887-10	543	750	550										■	
988-10	617	750	620										■	

Type MCECM/MCHCM														
Size DA mm	Shaft distance S		Preferred dimension V MCECM											
	MCECM min. mm	MCHCM min. mm		100	140	180	200	250	300	{127} 5"	{177.8} 7"	{228.6} 9"	-	
86-6	93	340	140		■									
103-6	94	340	140		■									
122-6	105	340	140		■									
133-6	105	340	140		■									
159-6	120	340	140		■									
174-6	120	340	140		■									
184-6	155	410	200				■							
203-6	160	410	200				■							
217-6	165	410	200				■							
251-6	200	420	250					■						
268-6	210	420	250					■						
291-6	210	420	250					■						
318-6	250	500	300						■					
343-6	250	500	300						■					

■ Preferred dimensions ■ Available standard dimensions

Type MCECM/MCHCM															
Size DA	Shaft distance S		Preferred dimension V MCECM												
	MCECM min. mm	MCHCM min. mm		100	140	180	200	250	300	(127) 5"	(177.8) 7"	(228.6) 9"	-		
219-8	207	428	218												
241-8	217	432	222												
262-8	233	438	268												
285-8	260	448	278												
302-8	285	456	286												
321-8	308	512	312												
354-8	330	516	366												
387-8	338	492	342												
411-8	350	494	394												
447-8	372	502	402												
495-8	387	706	406												
546-8	413	714	414												
587-8	435	720	440												
631-8	458	724	464												

Type MFEFM/MFHFM															
Size DA	Shaft distance S		Preferred dimension V MFEFM												
	MFEFM min. mm	MFHFM min. mm		100	140	180	200	250	300	(127) 5"	(177.8) 7"	(228.6) 9"	-		
86-6	93	340	140												
103-6	94	340	140												
122-6	105	340	140												
133-6	105	340	140												
159-6	120	340	140												
174-6	120	340	140												
184-6	155	410	200												
203-6	160	410	200												
217-6	165	410	200												
251-6	200	420	250												
268-6	210	420	250												
291-6	210	470	300												
318-6	250	500	300												
343-6	250	500	300												
219-8	207	428	218												
241-8	217	432	222												
262-8	233	438	268												
285-8	260	448	278												
302-8	285	456	286												
321-8	308	512	312												
354-8	330	516	366												
387-8	338	492	342												
411-8	350	494	394												
447-8	372	502	402												
495-8	387	706	406												
546-8	413	714	414												
587-8	435	720	440												
631-8	458	724	464												
495-10	387	706	406												
546-10	413	714	414												
587-10	435	720	440												
631-10	458	724	464												
694-10	552	752	552												
734-10	600	764	604												
790-10	646	930	650												
887-10	749	956	756												
988-10	857	900	860												

■ Preferred dimensions ■ Available standard dimensions

TYPE NEN/NHN

Torsionally rigid couplings of type NEN (NHN) with radially freely demountable intermediate spacer and catching device to secure the intermediate spacer in the event of

plate breakage. Standard coupling type in accordance with **API 610**. Coupling type in accordance with **API 671** (up to $n = 1800$ rpm) possible.

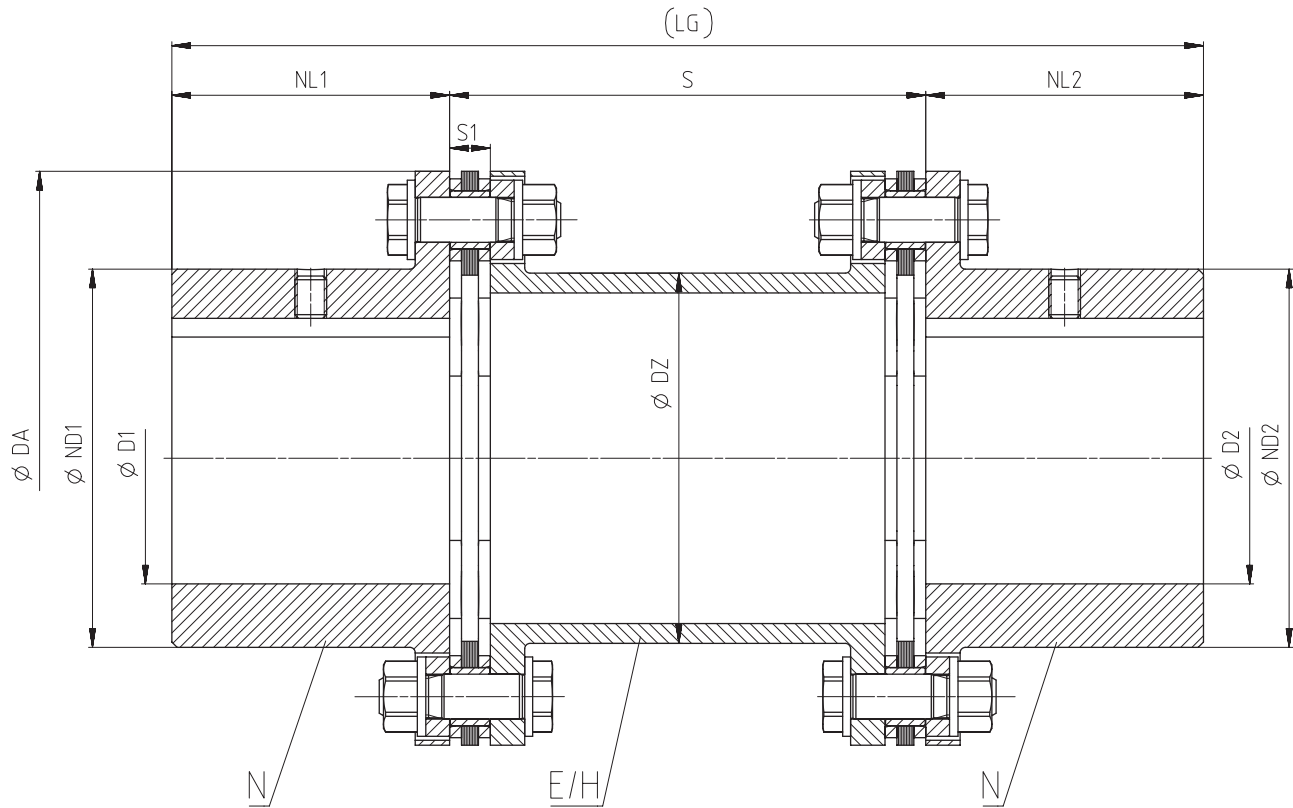

Size DA mm	Rated torque T_{KN} kNm	Maximum speed n_{Kmax} rpm	Dimensions in mm							Preferred dimension V		Article no. ¹⁾		Weight <i>m</i> kg
			D1/D2 Keyway DIN 6885-1 max.	ND1/ ND2	NL1/ NL2	DZ	S1	Shaft distance S		NEN	LG	E spacer (NEN)	H spacer (NHN)	
86-6	0.35	24000	42	56	45	45	8	53	300	100	190	2LC0370-0AA	2LC0370-0AL	1.9
103-6	0.5	20000	55	73	55	60	8.4	54	300	100	210	2LC0370-1AA	2LC0370-1AL	3
122-6	0.95	17000	65	85	65	73	8.8	65	300	100	230	2LC0370-2AA	2LC0370-2AL	5.1
133-6	1.25	15000	75	96	75	85	9.6	65	300	100	250	2LC0370-3AA	2LC0370-3AL	6.4
159-6	2.1	13000	80	104	80	97	11.6	80	300	100	260	2LC0370-4AA	2LC0370-4AL	9.6
174-6	2.5	12000	90	118	85	116	12.8	80	300	100	270	2LC0370-5AA	2LC0370-5AL	11.8
184-6	3.8	11000	95	124	90	123	14.6	95	350	140	320	2LC0370-6AA	2LC0370-6AL	16.4
203-6	5	10000	100	135	95	128	15	100	350	140	330	2LC0370-7AA	2LC0370-7AL	21.3
217-6	6.2	9500	110	143	105	140	15.4	105	350	140	350	2LC0370-8AA	2LC0370-8AL	24.4
251-6	10.5	8000	120	160	110	160	20.6	130	350	180	400	2LC0371-0AA	2LC0371-0AL	38
268-6	13.8	7500	130	170	130	166	22	140	350	180	440	2LC0371-1AA	2LC0371-1AL	48.6
291-6	18.2	7000	145	190	140	188	22.8	140	350	180	460	2LC0371-2AA	2LC0371-2AL	62.8
318-6	23	6500	155	205	150	197	23.2	150	400	200	500	2LC0371-3AA	2LC0371-3AL	83.9
343-6	28	6000	170	230	160	223	24	150	400	200	520	2LC0371-4AA	2LC0371-4AL	104

¹⁾ To identify complete item numbers specifying the available finish boring options and – if necessary – further order options, please use our configurators on flender.com.

²⁾ The S shaft spacing standard dimensions available for each size can be found on Page 6/10.

➤ For online configuration on flender.com, click on the item no.

Size DA mm	Rated torque T_{KN} kNm	Maximum speed n_{Kmax} rpm	Dimensions in mm										Article no. ¹⁾		Weight <i>m</i> kg
			D1/D2 Keyway DIN 6885-1 max.	ND1/ ND2	NL1/ NL2	DZ	S1	Shaft distance S		Preferred dimension V NEN	LG	Intermediate spacer			
								NEN min.	NHN min.			E spacer (NEN)	H spacer (NHN)		
219-8	10	9500	100	137	115	124	12.2	129	350	140	370	2LC0380-0AA	2LC0380-0AL	31.9	
241-8	15	8700	110	150	127	135	12.6	135	350	140	394	2LC0380-1AA	2LC0380-1AL	41.3	
262-8	20	8000	120	163	138	148	13.8	145	350	180	456	2LC0380-2AA	2LC0380-2AL	53.8	
285-8	27	7300	130	177	150	162	15.2	162	350	180	480	2LC0380-3AA	2LC0380-3AL	70.8	
302-8	35	6900	140	192	161	174	17.2	179	350	180	502	2LC0380-4AA	2LC0380-4AL	89.4	
321-8	43	6500	150	206	173	189	21	196	400	200	546	2LC0380-5AA	2LC0380-5AL	109	
354-8	56	5900	170	232	196	216	23.6	214	400	250	642	2LC0380-6AA	2LC0380-6AL	149	
387-8	72	5400	190	258	219	240	26	246	400	250	688	2LC0380-7AA	2LC0380-7AL	193	
411-8	93	5100	200	272	230	250	29.6	256	400	300	760	2LC0380-8AA	2LC0380-8AL	236	
447-8	122	4600	220	299	253	275	32.6	270	400	300	806	2LC0381-0AA	2LC0381-0AL	299	
495-8	160	4200	250	340	288	312	33.8	281	600	300	876	2LC0381-1AA	2LC0381-1AL	402	
546-8	212	3800	280	381	322	351	40	299	600	300	944	2LC0381-2AA	2LC0381-2AL	547	
587-8	270	3500	300	408	345	363	45	315	600	320	1010	2LC0381-3AA	2LC0381-3AL	690	
631-8	350	3300	320	435	368	399	48.8	334	600	340	1076	2LC0381-4AA	2LC0381-4AL	835	
495-10	200	4200	250	340	288	312	33.8	281	600	300	876	2LC0390-0AA	2LC0390-0AL	402	
546-10	270	3800	280	381	322	351	40	299	600	300	944	2LC0390-1AA	2LC0390-1AL	547	
587-10	352	3500	300	408	345	363	45	315	600	320	1010	2LC0390-2AA	2LC0390-2AL	690	
631-10	450	3300	320	435	368	399	48.8	334	600	340	1076	2LC0390-3AA	2LC0390-3AL	834	
694-10	630	3000	350	485	403	435	58	400	600	400	1206	2LC0390-4AA	2LC0390-4AL	1213	
734-10	760	2800	370	512	426	459	63	436	600	440	1292	2LC0390-5AA	2LC0390-5AL	1463	
790-10	950	2600	400	555	460	496	66	466	750	470	1390	2LC0390-6AA	2LC0390-6AL	1837	
887-10	1400	2300	450	627	518	546	78	543	750	550	1586	2LC0390-7AA	2LC0390-7AL	2713	
988-10	2000	2100	500	696	575	596	86	617	750	620	1770	2LC0390-8AA	2LC0390-8AL	3868	

Configurable variants ¹⁾

- ØD1 Without finished bore
With finished bore
- ØD2 Without finished bore
With finished bore
- Shaft distance S ²⁾ Metric (mm): 100 mm, 140 mm, 180 mm, 200 mm, 250 mm, 300 mm
Imperial (inches): 3.5" (88.9 mm), 5" (127 mm), 7" (177.8 mm), 9" (228.6 mm)
Any required (mm)

Notes

- Spacer sleeves (type NEN) designed as electrical cable sleeves are API compliant.
- Hubs are designed with threaded pull-off holes. Special lengths available upon request.
- The total lengths and the weights apply to the whole coupling of type NEN with maximum bores D1/D2 and the preferred shaft distance S = V.
- In cases with large shaft distances S the intermediate spacer can be designed as an H-spacer. The tube diameters here may slightly diverge. More precise coupling data in cases of variable shaft distances and E- / H-spacers are given on pages 6/23 to 6/28.
- E-spacers in preferred lengths up to size 343-6 are available from stock.

Ordering example

- N-ARPEX ARN-6 NEN coupling, size 217-6, with shaft distance S = 140 mm
- Bore ØD1 50H7 mm, keyway to DIN 6885-1 P9 and set screw (L1C)
- Bore ØD2 60H7 mm, keyway to DIN 6885-1 P9 and set screw (M1E)

Article no.: 2LC0370-8AA99-0AB0-Z L1C+M1E

¹⁾ To identify complete item numbers specifying the available finish boring options and – if necessary – further order options, please use our configurators on fletcher.com.

²⁾ The S shaft spacing standard dimensions available for each size can be found on Page 6/10.

➤ For online configuration on fletcher.com, click on the item no.

TYPE MCECM/MCHCM

Torsionally rigid couplings of type MCECM (MCHCM) with radially freely demountable pre-assembled intermediate unit and catching device to secure the intermediate spacer

in the event of plate breakage. Standard coupling type in accordance with **API 610**. Coupling type in accordance with **API 671** possible.

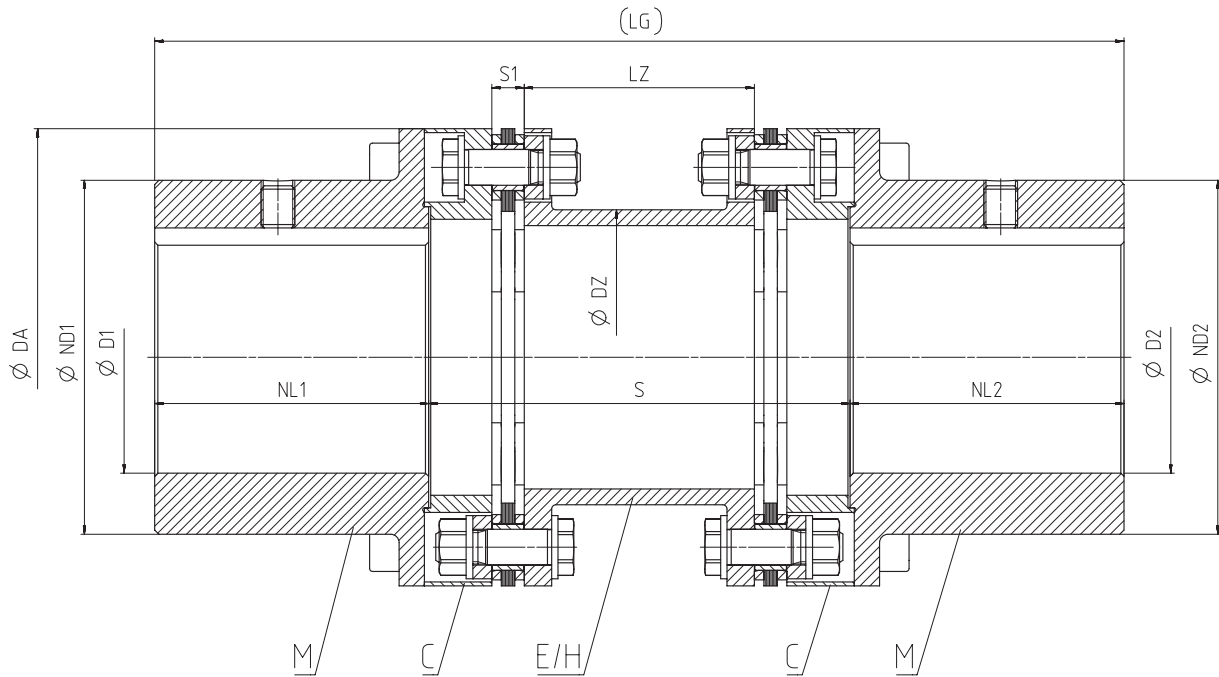

Size DA	Rated torque T_{KN}	Maximum speed n_{Kmax}	Dimensions in mm										Article no. ¹⁾		Weight <i>m</i>
			D1/D2 Keyway DIN 6885-1 max.	ND1/ ND2	NL1/ NL2	DZ	LZ	S1	Shaft distance S		Preferred dimension V	LG	Intermediate spacer		
mm	kNm	rpm							MCECM min.	MCHCM min.	MCECM		E spacer (MCECM)	H spacer (MCHCM)	kg
86-6	0.35	24000	42	62	42	45	84	8	93	340	140	224	2LC0370-0AC	2LC0370-0AM	3.1
103-6	0.5	20000	55	72	55	60	83.2	8.4	94	340	140	250	2LC0370-1AC	2LC0370-1AM	4.7
122-6	0.95	17000	70	91	70	73	82.4	8.8	105	340	140	280	2LC0370-2AC	2LC0370-2AM	7.7
133-6	1.25	15000	80	103	80	85	80.8	9.6	105	340	140	300	2LC0370-3AC	2LC0370-3AM	9.6
159-6	2.1	13000	95	123	95	97	76.8	11.6	120	340	140	330	2LC0370-4AC	2LC0370-4AM	15.9
174-6	2.5	12000	105	136	105	116	74.4	12.8	120	340	140	350	2LC0370-5AC	2LC0370-5AM	19.3

Configurable variants ¹⁾

- $\varnothing D1$ Without finished bore
With finished bore
- $\varnothing D2$ Without finished bore
With finished bore
- Shaft distance S ²⁾ Metric (mm): 100 mm, 140 mm, 180 mm, 200 mm, 250 mm, 300 mm
Imperial (inches): 5" (127 mm), 7" (177.8 mm), 9" (228.6 mm)
Any required (mm)

¹⁾ To identify complete item numbers specifying the available finish boring options and – if necessary – further order options, please use our configurators on flender.com.

²⁾ The S shaft spacing standard dimensions available for each size can be found on Page 6/10.

➤ For online configuration on flender.com, click on the item no.

Size DA	Rated torque T_{KN}	Maximum speed n_{Kmax}	Dimensions in mm											Article no. ¹⁾		Weight <i>m</i>
			D1/D2 Keyway DIN 6885-1 max.	ND1/ ND2	NL1/ NL2	DZ	LZ	S1	Shaft distance S		Preferred dimension V MCECM	LG	Intermediate spacer			
									MCECM min.	MCHCM min.			E spacer (MCECM)	H spacer (MCHCM)		
mm	kNm	rpm													kg	
184-6	3.8	11000	110	142	110	123	110.8	14.6	155	410	200	420	2LC0370-6AC	2LC0370-6AM	26.6	
203-6	5	10000	115	150	115	128	110	15	160	410	200	430	2LC0370-7AC	2LC0370-7AM	33.7	
217-6	6.2	9500	130	168	130	140	109.2	15.4	165	410	200	460	2LC0370-8AC	2LC0370-8AM	40.3	
251-6	10.5	8000	150	193	150	160	138.8	20.6	200	420	250	550	2LC0371-0AC	2LC0371-0AM	64.4	
268-6	13.8	7500	160	206	160	166	136	22	210	420	250	570	2LC0371-1AC	2LC0371-1AM	78.8	
291-6	18.2	7000	170	221	170	188	134.4	22.8	210	420	250	590	2LC0371-2AC	2LC0371-2AM	98.3	
318-6	23	6500	190	245	190	197	153.6	23.2	250	500	300	680	2LC0371-3AC	2LC0371-3AM	139	
343-6	28	6000	205	267	205	223	152	24	250	500	300	710	2LC0371-4AC	2LC0371-4AM	168	
219-8	10	9500	140	179	140	124	115.6	12.2	207	428	218	498	2LC0380-0AC	2LC0380-0AM	50.3	
241-8	15	8700	155	201	155	135	114.8	12.6	217	432	222	532	2LC0380-1AC	2LC0380-1AM	68.2	
262-8	20	8000	165	218	165	148	152.4	13.8	233	438	268	598	2LC0380-2AC	2LC0380-2AM	89	
285-8	27	7300	185	239	185	162	149.6	15.2	260	448	278	648	2LC0380-3AC	2LC0380-3AM	115	
302-8	35	6900	190	250	190	174	145.6	17.2	285	456	286	666	2LC0380-4AC	2LC0380-4AM	140	
321-8	43	6500	205	269	205	189	158	21	308	512	312	722	2LC0380-5AC	2LC0380-5AM	171	
354-8	56	5900	230	296	230	216	202.8	23.6	330	516	366	826	2LC0380-6AC	2LC0380-6AM	220	
387-8	72	5400	255	329	255	240	198	26	338	492	342	852	2LC0380-7AC	2LC0380-7AM	275	
411-8	93	5100	270	347	270	250	240.8	29.6	350	494	394	934	2LC0380-8AC	2LC0380-8AM	332	
447-8	122	4600	290	375	290	275	234.8	32.6	372	502	402	982	2LC0381-0AC	2LC0381-0AM	419	
495-8	160	4200	325	423	325	312	232.4	33.8	387	706	406	1056	2LC0381-1AC	2LC0381-1AM	561	
546-8	212	3800	360	468	360	351	220	40	413	714	414	1134	2LC0381-2AC	2LC0381-2AM	752	
587-8	270	3500	380	499	380	363	230	45	435	720	440	1200	2LC0381-3AC	2LC0381-3AM	945	
631-8	350	3300	410	535	410	399	242.4	48.8	458	724	464	1284	2LC0381-4AC	2LC0381-4AM	1146	

Configurable variants ¹⁾

- ØD1 Without finished bore
With finished bore
- ØD2 Without finished bore
With finished bore
- Shaft distance S ²⁾ Metric (mm): 100 mm, 140 mm, 180 mm, 200 mm, 250 mm, 300 mm
Imperial (inches): 5" (127 mm), 7" (177.8 mm), 9" (228.6 mm)
Any required (mm)

Notes

- Spacer sleeves (type MCECM) designed as electrical cable sleeves are API compliant.
- Hubs are designed with threaded pull-off holes. Special lengths available upon request.
- The total lengths, the spacer lengths and the weights apply to the whole coupling of type MCECM with maximum bores D1/D2 and the preferred shaft distance S = V.
- In cases with large shaft distances S the intermediate spacer can be designed as an H-spacer. The tube diameters here may slightly diverge. More precise coupling data in cases of variable shaft distances and E- / H-spacers are given on pages 6/23 to 6/28.
- Plate packs in the CEC/CHC intermediate unit assembled at the factory.
- E-spacers in preferred lengths up to size 343-6 are available from stock.

Ordering example

- N-ARPEX ARN-6 MCECM coupling, size 217-6, with shaft distance S = 200 mm
- Bore ØD1 60H7 mm, keyway to DIN 6885-1 P9 and set screw (L1G)
- Bore ØD2 70H7 mm, keyway to DIN 6885-1 P9 and set screw (M1G)

Article no.: 2LC0370-8AC99-0AD0-Z L1G+M1G

¹⁾ To identify complete item numbers specifying the available finish boring options and – if necessary – further order options, please use our configurators on flender.com.

²⁾ The S shaft spacing standard dimensions available for each size can be found on Page 6/10.

➤ For online configuration on flender.com, click on the item no.

TYPE MFEFM/MFHFM

Torsionally rigid type MFEFM (MFHFM) couplings with enlarged bore capacity and radially freely demountable intermediate unit and catching device to secure the inter-

mediate spacer in the event of plate breakage. Standard coupling type in accordance with **API 610**. Coupling type in accordance with **API 671** possible.

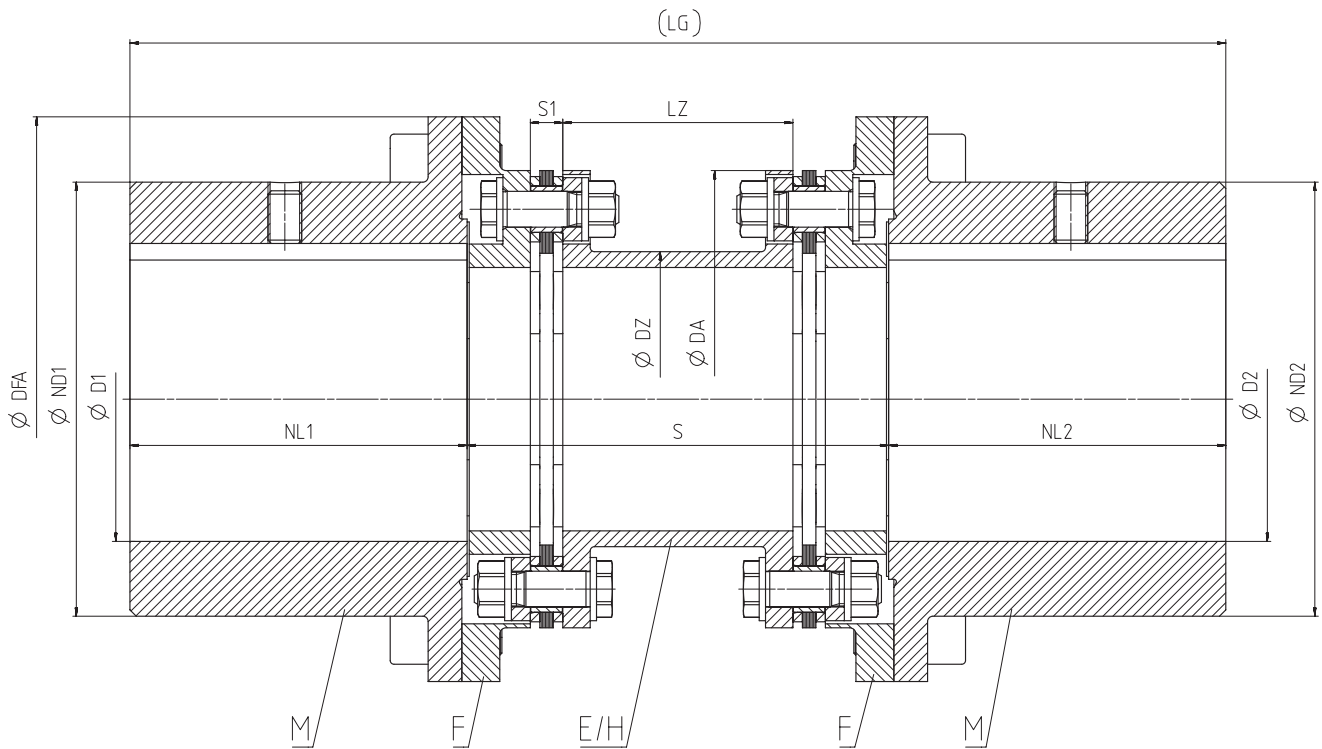

Size	Rated torque T_{KN}	Maximum speed n_{Kmax}	Dimensions in mm										Article no. ¹⁾		Weight m kg		
			DFA	D1/D2 Keyway DIN 6885-1 max.	ND1/ ND2	NL1/ NL2	DZ	LZ	S1	Shaft distance S		Preferred dimension V	LG	Intermediate spacer			
mm	kNm	rpm									MFEFM min.	MFHFM min.	MFEFM		E spacer (MFEFM)	H spacer (MFHFM)	
86-6	0.35	17000	122	70	91	70	45	84	8	93	340	340	140	280	2LC0370-0BA	2LC0370-0BC	6
103-6	0.5	15000	133	80	103	80	60	83.2	8.4	94	340	340	140	300	2LC0370-1BA	2LC0370-1BC	8
122-6	0.95	13000	159	95	123	95	73	82.4	8.8	105	340	340	140	330	2LC0370-2BA	2LC0370-2BC	13.6
133-6	1.25	12000	174	105	136	105	85	80.8	9.6	105	340	340	140	350	2LC0370-3BA	2LC0370-3BC	17.1
159-6	2.1	10000	203	115	150	115	97	76.8	11.6	120	340	340	140	370	2LC0370-4BA	2LC0370-4BC	22.9
174-6	2.5	9500	217	130	168	130	116	74.4	12.8	120	340	340	140	400	2LC0370-5BA	2LC0370-5BC	26.8
184-6	3.8	8000	251	150	193	150	123	110.8	14.6	155	410	200	500	2LC0370-6BA	2LC0370-6BC	40.1	
203-6	5	8000	251	150	193	150	128	110	15	160	410	200	500	2LC0370-7BA	2LC0370-7BC	52.8	
217-6	6.2	7500	268	160	206	160	140	109.2	15.4	165	410	200	520	2LC0370-8BA	2LC0370-8BC	63.4	
251-6	10.5	6500	318	190	245	190	160	138.8	20.6	200	420	250	630	2LC0371-0BA	2LC0371-0BC	109	

Configurable variants ¹⁾

- $\varnothing D1$ Without finished bore
With finished bore
- $\varnothing D2$ Without finished bore
With finished bore
- Shaft distance S ²⁾ Metric (mm): 100 mm, 140 mm, 180 mm, 200 mm, 250 mm, 300 mm
Imperial (inches): 5" (127 mm), 7" (177.8 mm), 9" (228.6 mm)
Any required (mm)

¹⁾ To identify complete item numbers specifying the available finish boring options and – if necessary – further order options, please use our configurators on flender.com.

²⁾ The S shaft spacing standard dimensions available for each size can be found on [Page 6/10](http://flender.com).

➤ For online configuration on flender.com, click on the item no.

Size DA	Rated torque T_{KN}	Maximum speed n_{Kmax}	Dimensions in mm										Article no. ¹⁾		Weight <i>m</i> kg	
			DFA	D1/D2 Keyway DIN 6885-1 max.	ND1/ ND2	NL1/ NL2	DZ	LZ	S1	Shaft distance S		Preferred dimension V MFEFM	LG	Intermediate spacer		
										MFEFM min.	MFHFM min.			E spacer (MFEFM)		H spacer (MFHFM)
268-6	13.8	6000	343	205	267	205	166	136	22	210	420	250	660	2LC0371-1BA	2LC0371-1BC	136
291-6	18.2	5500	356	230	302	230	188	134.4	22.8	210	470	300	760	2LC0371-2BA	2LC0371-2BC	190
318-6	23	5500	375	245	321	245	197	153.6	23.2	250	500	300	790	2LC0371-3BA	2LC0371-3BC	221
343-6	28	4500	424	270	354	270	223	152	24	250	500	300	840	2LC0371-4BA	2LC0371-4BC	284
219-8	10	7800	267	165	219	165	124	115.6	12.2	207	428	218	548	2LC0380-0BA	2LC0380-0BC	77.7
241-8	15	7200	289	185	241	185	135	114.8	12.6	217	432	222	592	2LC0380-1BA	2LC0380-1BC	98.6
262-8	20	6600	314	200	262	200	148	152.4	13.8	233	438	268	668	2LC0380-2BA	2LC0380-2BC	131
285-8	27	6100	339	215	285	215	162	149.6	15.2	260	448	278	708	2LC0380-3BA	2LC0380-3BC	169
302-8	35	5900	356	230	302	230	174	145.6	17.2	285	456	286	746	2LC0380-4BA	2LC0380-4BC	200
321-8	43	5600	375	245	321	245	189	158	21	308	512	312	802	2LC0380-5BA	2LC0380-5BC	237
354-8	56	4900	424	270	354	270	216	202.8	23.6	330	516	366	906	2LC0380-6BA	2LC0380-6BC	315
387-8	72	4500	457	295	387	295	240	198	26	338	492	342	932	2LC0380-7BA	2LC0380-7BC	384
411-8	93	4300	481	315	411	315	250	240.8	29.6	350	494	394	1024	2LC0380-8BA	2LC0380-8BC	460
447-8	122	4000	519	340	447	340	275	234.8	32.6	372	502	402	1082	2LC0381-0BA	2LC0381-0BC	586
495-8	160	3700	567	380	495	380	312	232.4	33.8	387	706	406	1166	2LC0381-1BA	2LC0381-1BC	758
546-8	212	3300	624	420	546	420	351	220	40	413	714	414	1254	2LC0381-2BA	2LC0381-2BC	1011
587-8	270	3100	669	450	587	450	363	230	45	435	720	440	1340	2LC0381-3BA	2LC0381-3BC	1270
631-8	350	2900	719	480	631	480	399	242.4	48.8	458	724	464	1424	2LC0381-4BA	2LC0381-4BC	1581
495-10	200	3700	567	380	495	380	312	232.4	33.8	387	706	406	1166	2LC0390-0BA	2LC0390-0BC	757
546-10	270	3300	624	420	546	420	351	220	40	413	714	414	1254	2LC0390-1BA	2LC0390-1BC	1010
587-10	350	3100	669	450	587	450	363	230	45	435	720	440	1340	2LC0390-2BA	2LC0390-2BC	1268
631-10	450	2900	719	480	631	480	399	242.4	48.8	458	724	464	1424	2LC0390-3BA	2LC0390-3BC	1578
694-10	630	2600	790	530	694	530	435	284	58	552	752	552	1612	2LC0390-4BA	2LC0390-4BC	2165
734-10	750	2500	830	560	734	560	459	314	63	600	764	604	1724	2LC0390-5BA	2LC0390-5BC	2586
790-10	950	2300	896	600	790	600	496	338	66	646	930	650	1850	2LC0390-6BA	2LC0390-6BC	3263
887-10	1400	2000	1013	680	887	680	546	394	78	749	956	756	2116	2LC0390-7BA	2LC0390-7BC	4716
988-10	2000	1800	1114	760	988	760	596	448	86	857	900	860	2380	2LC0390-8BA	2LC0390-8BC	6574

Configurable variants¹⁾

- ØD1 Without finished bore
With finished bore
- ØD2 Without finished bore
With finished bore
- Shaft distance S ²⁾ Metric (mm): 100 mm, 140 mm, 180 mm, 200 mm, 250 mm, 300 mm
Imperial (inches): 5" (127 mm), 7" (177.8 mm), 9" (228.6 mm)
Any required (mm)

Notes

- Spacer sleeves (type MFEFM) designed as electrical cable sleeves are API compliant.
- Hubs are designed with threaded pull-off holes. Special lengths available upon request.
- The total lengths, the spacer lengths and the weights apply to the whole coupling of type MFEFM with maximum bores D1/D2 and the preferred shaft distance S = V.
- In cases with large shaft distances S the intermediate spacer can be designed as an H-spacer. The tube diameters here may slightly diverge. More precise coupling data in cases of variable shaft distances and E- / H-spacers are given on pages 6/23 to 6/28.
- Plate packs in the FEF/FHF intermediate unit assembled at the factory.
- E-spacers in preferred lengths up to size 343-6 are available from stock.

Ordering example

- N-ARPEX ARN-6 MFEFM coupling, size 217-6, with shaft distance S = 200 mm
- Bore ØD1 80H7 mm, keyway to DIN 6885-1 P9 and set screw **(L1J)**
- Bore ØD2 90H7 mm, keyway to DIN 6885-1 P9 and set screw **(M1L)**

Article no.: 2LC0370-8BA99-0AD0-Z L1J+M1L

¹⁾ To identify complete item numbers specifying the available finish boring options and – if necessary – further order options, please use our configurators on flender.com.
²⁾ The S shaft spacing standard dimensions available for each size can be found on Page 6/10.
 ↗ For online configuration on flender.com, click on the item no.

TYPE BEB

Torsionally rigid type BEB couplings with smallest possible shaft distance.

Type BEB cannot be freely demounted radially without shifting the units.

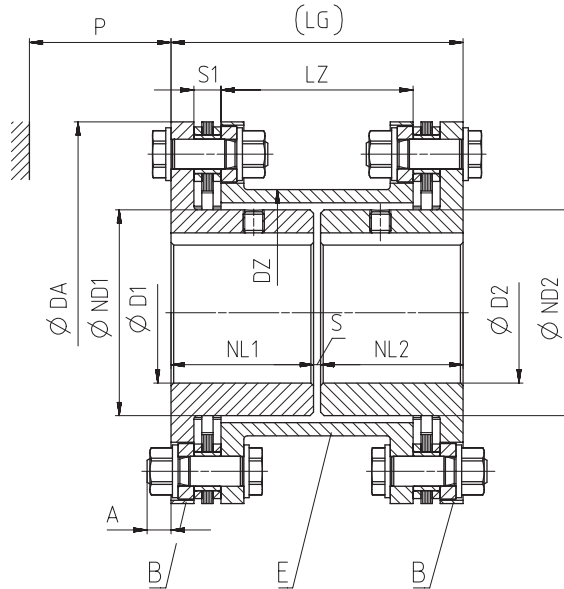

6

Size DA	Rated torque T_{KN}	Maximum speed n_{Kmax}	Dimensions in mm										Article no. ¹⁾	Weight m	
			D1/D2 Keyway DIN 6885-1 max.	ND1/ ND2	NL1/ NL2	DZ	LZ	S1	Shaft distance S	A	P	LG			kg
mm	kNm	rpm													
86-6	0.35	24000	22	35	30	45	44	8	12	8	32	72	SLC0370-0AB	1.5	
103-6	0.5	20000	38	50	34	60	43.2	8.4	4	8	32	72	SLC0370-1AB	2.0	
122-6	0.95	17000	48	62	56	73	82.4	8.8	4	8	38	116	2LC0370-2AB	4.2	
133-6	1.25	15000	55	72	56	85	80.8	9.6	4	7	38	116	2LC0370-3AB	5.1	
159-6	2.1	13000	65	84	57	97	76.8	11.6	6	9	48	120	2LC0370-4AB	8.1	
174-6	2.5	12000	75	102	77	116	114.4	12.8	4	10	48	158	2LC0370-5AB	11.4	
184-6	3.8	11000	80	106	80	123	110.8	14.6	6	15	64	166	2LC0370-6AB	15.2	
203-6	5	10000	85	111	80	128	110	15	6	14	64	166	2LC0370-7AB	18.2	
217-6	6.2	9500	90	124	81	140	109.2	15.4	4	14	66	166	2LC0370-8AB	22.0	
251-6	10.5	8000	100	137	102	160	138.8	20.6	6	15	77	210	2LC0371-0AB	35.6	
268-6	13.8	7500	108	143	105	166	136	22	12	11	89	222	2LC0371-1AB	44.8	
291-6	18.2	7000	120	162	106	188	134.4	22.8	10	11	89	222	2LC0371-2AB	56.7	
318-6	23	6500	130	164	118	197	153.6	23.2	6	20	100	242	2LC0371-3AB	70.2	
343-6	28	6000	150	186	143	223	202	24	6	19	100	292	2LC0371-4AB	87.7	

Configurable variants ¹⁾

- ØD1 Without finished bore
With finished bore
- ØD2 Without finished bore
With finished bore

Notes

- Hubs are designed with threaded pull-off holes. Special lengths available upon request.
- The total lengths and the weights apply to the whole coupling with maximum bores D1/D2 and the preferred shaft distance S = V.

¹⁾ To identify complete item numbers specifying the available finish boring options and – if necessary – further order options, please use our configurators on flender.com.

Ordering example

- N-ARPEX ARN-6 BEB coupling, size 217-6, with shaft distance S = 4 mm
- Bore ØD1 50H7 mm, keyway to DIN 6885-1 and set screw **(L1C)**
- Bore ØD2 60H7 mm, keyway to DIN 6885-1 and set screw **(M1E)**

Article no.: **2LC0370-8AB99-0AA0-Z L1C+M1E**

➤ For online configuration on flender.com, click on the item no.

FURTHER HUBS

Clamping hubs, type 124 and 125

Type 124 and 125 standard clamping hubs can be combined with any spacer of the ARN-6 series.

It should be noted that the clamping hub can be used only as an "N hub" (hub core outside).

Function

N-ARPEX clamping hubs transmit torque with the aid of a flexible press fit. By pulling the clamping ring on by means of the tightening screws the necessary surface pressure

is applied in the "shaft/hub" contact area. After the tightening operation the clamping ring lies up against the clamping hub.

Transmissible torque

The clamping connections are designed to enable the specified maximum torques to be transmitted.

These maximum torques must not be exceeded, even in the case of overload.

Fitting clearance and surface roughness

The transmissible torques allow for the maximum fitting clearance for a quality IT6 bore and shaft and maximum surface roughness. For other shaft tolerances reduced torques or other bore tolerances must be used. The surface roughness of the shaft should be $\leq Ra = 1.6 \mu m$.

The fit pairing G6/h6 should be used wherever possible. Divergent shaft tolerances must be specified when ordering. The article no. for the specification must end in "-Z" and include the code "Y26" for the fit.

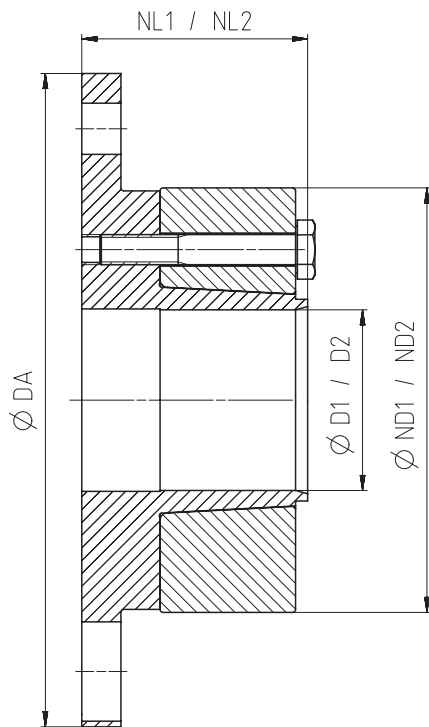

Type 124 (standard type)

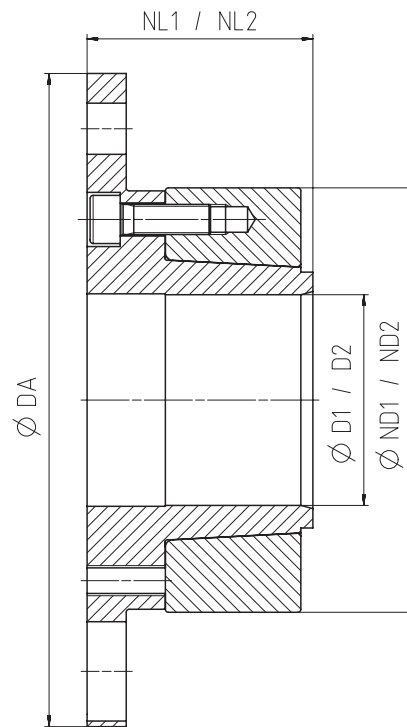

Type 125

FURTHER HUBS

Clamping hubs, type 124 and 125

Size DA mm	Clamping hub Type	Dimensions in mm		ND1/ND2	NL1/NL2	Mass moment of inertia <i>J</i> kgm ²	↗ Article no. ¹⁾	Weight <i>m</i> kg
		D1/D2 min.	max.					
86-6	124	19	25	50	35	0.0003	2LC0370-0LM90-0AA0 2LC0370-0LN90-0AA0	0.5
	125							
103-6	124	25	38	67	40	0.0009	2LC0370-1LM90-0AA0 2LC0370-1LN90-0AA0	0.9
	125							
122-6	124	30	42	77	45	0.0021	2LC0370-2LM90-0AA0 2LC0370-2LN90-0AA0	1.5
	125							
133-6	124	32	50	88	50	0.0034	2LC0370-3LM90-0AA0 2LC0370-3LN90-0AA0	2
	125							
159-6	124	35	60	105	55	0.0077	2LC0370-4LM90-0AA0 2LC0370-4LN90-0AA0	3.2
	125							
174-6	124	40	70	120	65	0.0135	2LC0370-5LM90-0AA0 2LC0370-5LN90-0AA0	4.6
	125							
184-6	124	45	70	126	70	0.0195	2LC0370-6LM90-0AA0 2LC0370-6LN90-0AA0	5.9
	125							
203-6	124	50	80	139	75	0.0298	2LC0370-7LM90-0AA0 2LC0370-7LN90-0AA0	7.4
	125							
217-6	124	60	90	147	90	0.0429	2LC0370-8LM90-0AA0 2LC0370-8LN90-0AA0	9.2
	125							
251-6	124	70	95	168	95	0.0837	2LC0371-0LM90-0AA0 2LC0371-0LN90-0AA0	14
	125							
268-6	124	75	100	175	115	0.1236	2LC0371-1LM90-0AA0 2LC0371-1LN90-0AA0	18.5
	125							
291-6	124	80	120	195	125	0.1907	2LC0371-2LM90-0AA0 2LC0371-2LN90-0AA0	22.9
	125							
318-6	124	85	120	209	140	0.2975	2LC0371-3LM90-0AA0 2LC0371-3LN90-0AA0	31.5
	125							
343-6	124	95	140	234	150	0.4539	2LC0371-4LM90-0AA0 2LC0371-4LN90-0AA0	39.6
	125							

Note

- Weights and mass moments of inertia apply to a clamping hub with a maximum bore D1/D2.

Ordering example:

- N-ARPEX clamping hub, type 124, size 133-6
- Shaft ØD1 = 40k6 (**L0W**)
- Y26** / fit specification supplied

Article no.: 2LC0370-3LM90-0AA0-Z L0W+Y26

Plain text Y26: k6

¹⁾ To identify complete item numbers specifying the available finish boring options and – if necessary – further order options, please use our configurators on [flender.com](https://www.flender.com).

↗ For online configuration on [flender.com](https://www.flender.com), click on the item no.

Dimensions and torques

Finished bore/shaft in standard fit	DA size in mm													
	86-6	103-6	122-6	133-6	159-6	174-6	184-6	203-6	217-6	251-6	268-6	291-6	318-6	343-6
D1 ⁶⁴ / _{h6} mm	Rated coupling torque T_{KN} in Nm													
	350	500	950	1250	2100	2500	3800	5000	6200	10500	13800	18200	23000	28000
	Maximum transmissible torque of the clamping hub Nm													
19	400	-	-	-	-	-	-	-	-	-	-	-	-	-
20	460	-	-	-	-	-	-	-	-	-	-	-	-	-
22	470	-	-	-	-	-	-	-	-	-	-	-	-	-
24	350	-	-	-	-	-	-	-	-	-	-	-	-	-
25	370	480	-	-	-	-	-	-	-	-	-	-	-	-
28	-	870	-	-	-	-	-	-	-	-	-	-	-	-
30	-	1150	1770	-	-	-	-	-	-	-	-	-	-	-
32	-	1140	1830	2300	-	-	-	-	-	-	-	-	-	-
35	-	570	1420	2360	3050	-	-	-	-	-	-	-	-	-
38	-	830	1720	3040	2710	-	-	-	-	-	-	-	-	-
40	-	-	1370	2610	3660	3680	-	-	-	-	-	-	-	-
42	-	-	1670	2930	2180	4020	-	-	-	-	-	-	-	-
45	-	-	-	2120	3750	4110	5780	-	-	-	-	-	-	-
48	-	-	-	2480	4160	4930	6200	-	-	-	-	-	-	-
50	-	-	-	2240	2300	4300	5840	7190	-	-	-	-	-	-
55	-	-	-	-	3310	5370	6410	7970	-	-	-	-	-	-
60	-	-	-	-	3260	3730	5370	8840	7570	-	-	-	-	-
65	-	-	-	-	-	4700	6240	8890	10390	-	-	-	-	-
70	-	-	-	-	-	4150	5920	8460	10640	14050	-	-	-	-
75	-	-	-	-	-	-	-	7960	9590	15350	20710	-	-	-
80	-	-	-	-	-	-	-	7340	8850	13510	20120	31840	-	-
85	-	-	-	-	-	-	-	-	7890	16370	21130	31230	36420	-
90	-	-	-	-	-	-	-	-	6290	14300	20810	33300	39050	-
95	-	-	-	-	-	-	-	-	-	13310	18570	33530	35940	54230
100	-	-	-	-	-	-	-	-	-	-	14440	31710	37500	56580
110	-	-	-	-	-	-	-	-	-	-	-	29020	35200	56900
120	-	-	-	-	-	-	-	-	-	-	-	22600	31490	53580
130	-	-	-	-	-	-	-	-	-	-	-	-	-	50910
140	-	-	-	-	-	-	-	-	-	-	-	-	-	43600

Note

- The maximum transmissible torque of the clamping hub must not be exceeded! Further clamping hub sizes and higher torques on request.

FURTHER SPACERS

Z spacer with enlarged tube cross section

The Z spacers can be used as an alternative to the E and H spacers in any type of the ARN-6 series (except for types with B hubs). Example designs are NZN, MCZCM or MFZFM.

Function

The Z spacer, like the H spacer, is used especially for longer shaft distances (up to 6500 mm). The difference to the H spacer is an increased tube diameter in order to increase the bending-critical speed and the torsional rigidity of the coupling. The Z spacers are delivered with unmachined, primed spacer tube.

Bending critical speed

The Z spacer has an enlarged tube diameter. Increasing the tube diameter increases the bending critical speed of the coupling and enables a higher operating speed and a larger shaft spacing compared to standard spacers for the same coupling size.

Torsional spring stiffness

The increased tube diameter of the Z spacer also creates an increased torsional spring stiffness of the intermediate spacer and the overall coupling. This increased torsional spring stiffness reduces the torsional angle of the overall coupling when a system torque is applied and enables torsionally rigid torque transmission between the shaft ends to be connected.

Ordering example

- N-ARPEX Z intermediate spacer, size 217-6, with spacer length LZ=3000 mm

Article no.: 2LC0370-8MA00-0AZ0 Q4Y

Plain text to Q4Y: 3000 mm (dimension S)

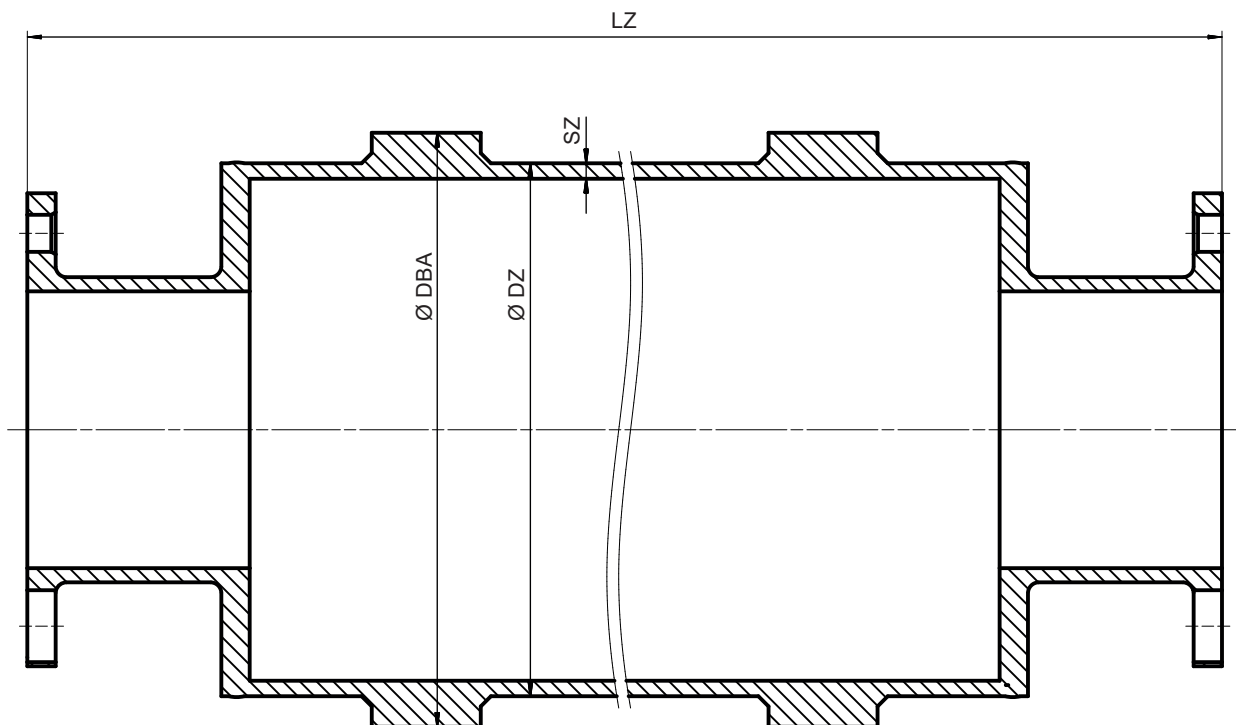

Z spacer from the ARN-6 series

Size	Dimensions in mm					Mass moment of inertia <i>J</i> kgm ²	➤ Article no. ¹⁾	Weight <i>m</i> kg	Torsional stiffness <i>C</i> MNm/rad
	DA mm	DBA	DZ	SZ	LZ _{min}				
86-6	119.5	101.6	5	407	2000	0.0370	2LC0370-0MA00-0A	16.7	0.144
103-6	132.5	114.3	5	407	2200	0.0544	2LC0370-1MA00-0A	19.3	0.291
122-6	157.5	139.7	5	425	2600	0.1019	2LC0370-2MA00-0A	24.8	0.531
133-6	189	168.3	5	425	3000	0.1912	2LC0370-3MA00-0A	32.1	0.909
159-6	198	177.8	5.6	455	3500	0.2406	2LC0370-4MA00-0A	36.5	1.19
174-6	230.5	203	6.3	420	4000	0.3868	2LC0370-5MA00-0A	42.1	2.01
184-6	243.5	216	8	460	4500	0.5329	2LC0370-6MA00-0A	52.7	2.59
203-6	247.5	219.1	7.1	460	5000	0.5299	2LC0370-7MA00-0A	50.8	2.78
217-6	272.5	244.5	7.1	466	6000	0.7348	2LC0370-8MA00-0A	56.9	3.6
251-6	308	273	7.1	500	6500	1.1183	2LC0371-0MA00-0A	70.4	5.46
268-6	334	298.5	8.8	550	6500	1.7058	2LC0371-1MA00-0A	93.6	6.52
291-6	359	323.9	8.8	552	6500	2.2355	2LC0371-2MA00-0A	106.0	10.7
318-6	378	343	8.8	576	6500	2.7138	2LC0371-3MA00-0A	119.2	13.5
343-6	403	368	10	576	6500	3.6737	2LC0371-4MA00-0A	139.3	20.5

Notes

- The permitted length of the intermediate spacer depends on the maximum operating speed of the coupling (see following table). In the case of individual order of the intermediate spacer, the length (LZ) must be specified.
- Weight, mass moment of inertia and torsional stiffness apply to a Z intermediate spacer with LZ=1000 mm.

¹⁾ To identify complete item numbers specifying the available finish boring options and – if necessary – further order options, please use our configurators on flender.com.

²⁾ Other spacer lengths on request.

➤ For online configuration on flender.com, click on the item no.

FURTHER SPACERS

Comparison of the bending-critical speed of Z spacers to H spacers depending on the spacer length LZ

The Z spacer has an increased tube diameter compared to the H spacer. Increasing the tube diameter increases the bending-critical speed of the coupling and enables a

higher maximum speed n_{max} and a longer spacer length LZ compared to standard spacers for the same coupling size.

Example

6

Size 174-6

Spacer distance LZ = 3000 mm

- Maximum speed H spacer $n_{max} = 1203 \text{ rpm}$
- Maximum speed Z spacer $n_{max} = 2074 \text{ rpm}$
(increase 72% compared to H spacer)

Size 343-6

Spacer distance LZ = 4000 mm

- Maximum speed H spacer $n_{max} = 1254 \text{ rpm}$
- Maximum speed Z spacer $n_{max} = 2115 \text{ rpm}$
(increase 69% compared to H spacer)

Size DA mm	Spacer length LZ in mm									
	1000		2000		3000		4000		5000	
	H spacer	Z spacer	H spacer	Z spacer	H spacer	Z spacer	H spacer	Z spacer	H spacer	Z spacer
	max. speed n_{max} in rpm									
86-6	4103	9105	1034	2295	-	-	-	-	-	-
103-6	5471	10291	1379	2594	-	-	-	-	-	-
122-6	6647	12668	1676	3195	-	-	-	-	-	-
133-6	7773	15000	1962	3869	875	1725	-	-	-	-
159-6	8857	13000	2240	4072	999	1817	-	-	-	-
174-6	10641	12000	2694	4646	1203	2074	678	1169	-	-
184-6	11000	11000	2811	4905	1255	2191	708	1235	-	-
203-6	10000	10000	2933	4997	1310	2232	739	1259	474	807
217-6	9500	9500	3237	5593	1446	2498	816	1409	523	903
251-6	8000	8000	3619	6231	1620	2788	914	1574	586	1009
268-6	7500	7500	3752	6780	1680	3035	948	1714	608	1099
291-6	7000	7000	4246	7000	1901	3300	1073	1863	689	1195
318-6	6500	6500	4385	6500	1964	3499	1109	1975	711	1267
343-6	6000	6000	4955	6000	2220	3746	1254	2115	804	1357

Limited by the general max. speed of the coupling

SPARE AND WEAR PARTS

Plate pack

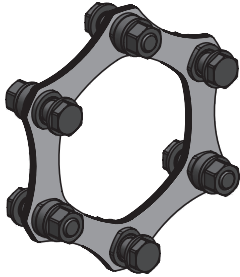

Size 86-6 to 343-6
(hexagon plates)

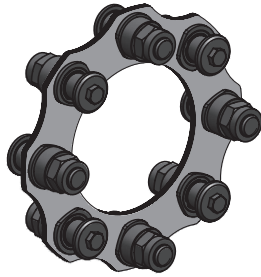

Size 219-8 to 631-8
(octagon plates)

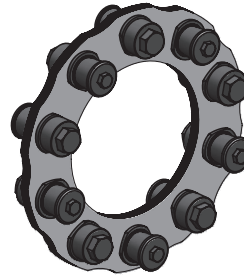

Size 495-10 to 631-10
(decagon plates)

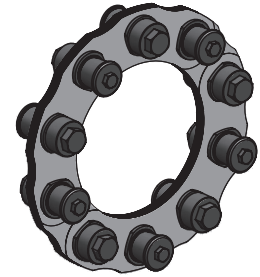

Size 694-10 to 988-10
(decagon plates/segment)

Size DA	Dimensions S1 mm	Mass moment of inertia J kgm ²	Article No.	Weight m kg
86-6	8	0.00018	2LC0370-0LP00-0AA0	0.17
103-6	8.4	0.00032	2LC0370-1LP00-0AA0	0.19
122-6	8.8	0.001	2LC0370-2LP00-0AA0	0.43
133-6	9.6	0.0014	2LC0370-3LP00-0AA0	0.49
159-6	11.6	0.0033	2LC0370-4LP00-0AA0	0.8
174-6	12.8	0.0047	2LC0370-5LP00-0AA0	0.93
184-6	14.6	0.0078	2LC0370-6LP00-0AA0	1.38
203-6	15	0.012	2LC0370-7LP00-0AA0	1.79
217-6	15.4	0.018	2LC0370-8LP00-0AA0	2.25
251-6	20.6	0.037	2LC0371-0LP00-0AA0	3.61
268-6	22	0.056	2LC0371-1LP00-0AA0	4.83
291-6	22.8	0.08	2LC0371-2LP00-0AA0	5.78
318-6	23.2	0.13	2LC0371-3LP00-0AA0	8.12
343-6	24	0.17	2LC0371-4LP00-0AA0	8.68
219-8	12.2	0.028	2LC0380-0LP00-0AA0	3.58
241-8	12.6	0.042	2LC0380-1LP00-0AA0	4.67
262-8	13.8	0.067	2LC0380-2LP00-0AA0	6.05
285-8	15.2	0.11	2LC0380-3LP00-0AA0	8.28
302-8	17.2	0.15	2LC0380-4LP00-0AA0	10.3
321-8	21	0.22	2LC0380-5LP00-0AA0	13.6
354-8	23.6	0.34	2LC0380-6LP00-0AA0	17
387-8	26	0.49	2LC0380-7LP00-0AA0	20.2
411-8	29.6	0.7	2LC0380-8LP00-0AA0	26
447-8	32.6	1.01	2LC0381-0LP00-0AA0	31.5
495-8	33.8	1.54	2LC0381-1LP00-0AA0	38.7
546-8	40	2.57	2LC0381-2LP00-0AA0	52.9
587-8	45	3.74	2LC0381-3LP00-0AA0	67.2
631-8	48.8	5.38	2LC0381-4LP00-0AA0	85
495-10	33.8	1.76	2LC0390-0LP00-0AA0	43.4
546-10	40	2.9	2LC0390-1LP00-0AA0	58.5
587-10	45	4.19	2LC0390-2LP00-0AA0	73.7
631-10	48.8	5.98	2LC0390-3LP00-0AA0	92.6
694-10	58	11.8	2LC0390-4LP00-0AA0	148
734-10	63	16.3	2LC0390-5LP00-0AA0	182
790-10	66	23.4	2LC0390-6LP00-0AA0	226
887-10	78	43.7	2LC0390-7LP00-0AA0	335
988-10	86	75.8	2LC0390-8LP00-0AA0	468

Notes

- The plate pack of the ARN-6/-8 series is readily available as a spare part.
- The plate pack is delivered with screw connection.
- Mainly ring plates are used for the plate packs. Sizes 694-10 to 988-10 plate packs are designed with segmented plates.

Ordering example

- N-ARPEX ARN-8 plate pack, size 354-8, complete with screw connection

Article no.: 2LC0380-6LP00-0AA0

LENGTH-DEPENDENT SPECIFICATIONS

of types NEN/ NHN, BEB, MCECM/MCHCM and MFEFM/MFHFM

A variant with an E-spacer is standardly provided for each N-ARPEX type. This has been machined all over in accordance with the requirements of **API 610** and **671**. Particularly for large shaft distances S and therefore for correspondingly long intermediate spacer it is usual to leave the inside and outside diameters of the tube in the condition in which it was delivered. These spacers are then referred to as H-spacers.

6

If a coupling is fitted with an H-spacer, the type designation changes accordingly. For example, an NEN becomes an NHN, an MFEFM becomes an MFHFN. No version with an H-spacer is provided for the BEB type. Length-dependent technical specifications for the various coupling types are shown on the following table.

The shaft distance S must be specified in mm. The specifications with regard to weight and mass moment of inertia refer to the whole coupling with maximum bores D1/ D2.

The values for torsional stiffness apply to the whole coupling (not including the hubs and customer shafts) and refer to the rated coupling torque T_{KN} . For determination of torsional stiffness for a specific operating point outside the nominal range Flender must be consulted.

Variant with E spacer

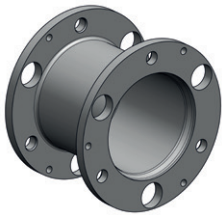

Size DA	Type	m kg	J kgm ²	C MNm/rad
86-6	NEN	1.55 + 0.003 · S	0.001 + 0.000002 · S	1/(1/0,08 + S/15)
	BEB	1.42 + 0.003 · S	0.001 + 0.000002 · S	1/(1/0,06 + S/15)
	MCECM	2.64 + 0.003 · S	0.003 + 0.000002 · S	1/(1/0,09 + S/15)
	MFEFM	5.54 + 0.003 · S	0.01 + 0.000002 · S	1/(1/0,09 + S/15)
103-6	NEN	2.52 + 0.005 · S	0.004 + 0.000004 · S	1/(1/0,11 + S/42)
	BEB	2.01 + 0.005 · S	0.003 + 0.000004 · S	1/(1/0,1 + S/42)
	MCECM	4 + 0.005 · S	0.006 + 0.000004 · S	1/(1/0,12 + S/42)
	MFEFM	7.28 + 0.005 · S	0.017 + 0.000004 · S	1/(1/0,12 + S/42)
122-6	NEN	4.39 + 0.007 · S	0.009 + 0.000008 · S	1/(1/0,26 + S/82)
	BEB	4.19 + 0.007 · S	0.008 + 0.000008 · S	1/(1/0,2 + S/82)
	MCECM	6.78 + 0.007 · S	0.015 + 0.000008 · S	1/(1/0,29 + S/82)
	MFEFM	12.6 + 0.007 · S	0.042 + 0.000008 · S	1/(1/0,29 + S/82)
133-6	NEN	5.5 + 0.009 · S	0.013 + 0.000014 · S	1/(1/0,33 + S/142)
	BEB	5.09 + 0.009 · S	0.011 + 0.000014 · S	1/(1/0,27 + S/142)
	MCECM	8.44 + 0.009 · S	0.023 + 0.000014 · S	1/(1/0,36 + S/142)
	MFEFM	15.86 + 0.009 · S	0.064 + 0.000014 · S	1/(1/0,36 + S/142)
159-6	NEN	8.54 + 0.011 · S	0.028 + 0.000023 · S	1/(1/0,54 + S/234)
	BEB	8 + 0.011 · S	0.026 + 0.000023 · S	1/(1/0,45 + S/234)
	MCECM	14.35 + 0.011 · S	0.055 + 0.000023 · S	1/(1/0,6 + S/234)
	MFEFM	21.37 + 0.011 · S	0.068 + 0.000023 · S	1/(1/0,6 + S/234)

Variant with H spacer

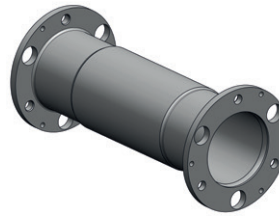

Size DA	Type	m kg	J kgm ²	C MNm/rad
86-6	NHN	1.11 + 0.005 · S	0.001 + 0.000003 · S	1/(1/0,05 + S/25)
	-	-	-	-
	MCHCM	2.13 + 0.005 · S	0.003 + 0.000003 · S	1/(1/0,06 + S/25)
	MFHFM	5.03 + 0.005 · S	0.01 + 0.000003 · S	1/(1/0,06 + S/25)
103-6	NHN	1.91 + 0.008 · S	0.003 + 0.000007 · S	1/(1/0,09 + S/68)
	-	-	-	-
	MCHCM	3.28 + 0.008 · S	0.006 + 0.000007 · S	1/(1/0,1 + S/68)
	MFHFM	6.56 + 0.008 · S	0.016 + 0.000007 · S	1/(1/0,1 + S/68)
122-6	NHN	3.72 + 0.01 · S	0.008 + 0.000012 · S	1/(1/0,21 + S/122)
	-	-	-	-
	MCHCM	6 + 0.01 · S	0.014 + 0.000012 · S	1/(1/0,22 + S/122)
	MFHFM	11.82 + 0.01 · S	0.041 + 0.000012 · S	1/(1/0,22 + S/122)
133-6	NHN	4.52 + 0.013 · S	0.012 + 0.000022 · S	1/(1/0,28 + S/221)
	-	-	-	-
	MCHCM	7.29 + 0.013 · S	0.021 + 0.000022 · S	1/(1/0,29 + S/221)
	MFHFM	14.71 + 0.013 · S	0.062 + 0.000022 · S	1/(1/0,29 + S/221)
159-6	NHN	7.17 + 0.017 · S	0.025 + 0.000037 · S	1/(1/0,45 + S/373)
	-	-	-	-
	MCHCM	12.76 + 0.017 · S	0.051 + 0.000037 · S	1/(1/0,47 + S/373)
	MFHFM	19.78 + 0.017 · S	0.064 + 0.000037 · S	1/(1/0,47 + S/373)

Variant with E spacer

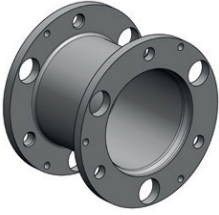

Size DA	Type	m kg	J kgm ²	C MNm/rad
174-6	NEN	10.57 + 0.013 · S	0.042 + 0.000039 · S	1/(1/0,64 + S/394)
	BEB	11.36 + 0.013 · S	0.041 + 0.000039 · S	1/(1/0,52 + S/394)
	MCECM	17.54 + 0.013 · S	0.08 + 0.000039 · S	1/(1/0,68 + S/394)
	MFEFM	25.02 + 0.013 · S	0.146 + 0.000039 · S	1/(1/0,68 + S/394)
184-6	NEN	13.94 + 0.017 · S	0.065 + 0.000059 · S	1/(1/1 + S/597)
	BEB	15.1 + 0.017 · S	0.066 + 0.000059 · S	1/(1/0,81 + S/597)
	MCECM	23.12 + 0.017 · S	0.081 + 0.000059 · S	1/(1/1,11 + S/597)
203-6	NEN	18.62 + 0.019 · S	0.102 + 0.00007 · S	1/(1/1,44 + S/705)
	BEB	18.09 + 0.019 · S	0.096 + 0.00007 · S	1/(1/1,13 + S/705)
	MCECM	29.96 + 0.019 · S	0.185 + 0.00007 · S	1/(1/1,65 + S/705)
	MFEFM	49.06 + 0.019 · S	0.414 + 0.00007 · S	1/(1/1,65 + S/705)
217-6	NEN	21.68 + 0.019 · S	0.137 + 0.000087 · S	1/(1/1,84 + S/870)
	BEB	21.93 + 0.019 · S	0.131 + 0.000087 · S	1/(1/1,43 + S/870)
	MCECM	36.46 + 0.019 · S	0.262 + 0.000087 · S	1/(1/2,11 + S/870)
251-6	NEN	32.32 + 0.032 · S	0.271 + 0.00018 · S	1/(1/2,24 + S/1827)
	BEB	35.42 + 0.032 · S	0.276 + 0.00018 · S	1/(1/1,85 + S/1827)
	MCECM	56.48 + 0.032 · S	0.539 + 0.00018 · S	1/(1/2,45 + S/1827)
	MFEFM	101.1 + 0.032 · S	1.397 + 0.00018 · S	1/(1/2,45 + S/1827)
268-6	NEN	44.91 + 0.02 · S	0.434 + 0.00013 · S	1/(1/2,78 + S/2063)
	BEB	44.58 + 0.02 · S	0.425 + 0.00013 · S	1/(1/2,27 + S/2063)
	MCECM	73.71 + 0.02 · S	0.8 + 0.00013 · S	1/(1/3,07 + S/2063)
291-6	NEN	55.18 + 0.042 · S	0.634 + 0.00034 · S	1/(1/3,77 + S/3400)
	BEB	56.23 + 0.042 · S	0.624 + 0.00034 · S	1/(1/3,17 + S/3400)
	MCECM	87.66 + 0.042 · S	1.124 + 0.00034 · S	1/(1/4,09 + S/3400)
	MFEFM	176.8 + 0.042 · S	3.213 + 0.00034 · S	1/(1/4,09 + S/3400)
318-6	NEN	72.12 + 0.059 · S	0.979 + 0.0005 · S	1/(1/5,13 + S/5040)
	BEB	69.81 + 0.059 · S	0.922 + 0.0005 · S	1/(1/4,29 + S/5040)
	MCECM	121.4 + 0.059 · S	1.89 + 0.0005 · S	1/(1/5,72 + S/5040)
343-6	NEN	89.26 + 0.075 · S	1.394 + 0.00081 · S	1/(1/5,26 + S/8178)
	BEB	87.3 + 0.075 · S	1.322 + 0.00081 · S	1/(1/4,55 + S/8178)
	MCECM	145.8 + 0.075 · S	2.639 + 0.00081 · S	1/(1/5,62 + S/8178)
	MFEFM	261.5 + 0.075 · S	6.626 + 0.00081 · S	1/(1/5,62 + S/8178)

Variant with H spacer

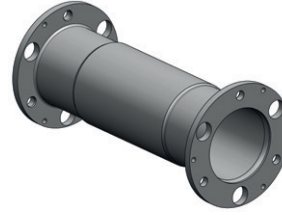

Size DA	Type	m kg	J kgm ²	C MNm/rad
174-6	NHN	8.79 + 0.02 · S	0.036 + 0.000065 · S	1/(1/0,55 + S/652)
	-	-	-	-
	MCHCM	15.46 + 0.02 · S	0.073 + 0.000065 · S	1/(1/0,57 + S/652)
	MFHFM	22.95 + 0.02 · S	0.139 + 0.000065 · S	1/(1/0,57 + S/652)
184-6	NHN	12.36 + 0.023 · S	0.059 + 0.000083 · S	1/(1/0,89 + S/839)
	-	-	-	-
	MCHCM	21.18 + 0.023 · S	0.074 + 0.000083 · S	1/(1/0,95 + S/839)
203-6	NHN	16.56 + 0.027 · S	0.093 + 0.0001 · S	1/(1/1,23 + S/1049)
	-	-	-	-
	MCHCM	27.42 + 0.027 · S	0.174 + 0.0001 · S	1/(1/1,33 + S/1049)
	MFHFM	46.52 + 0.027 · S	0.403 + 0.0001 · S	1/(1/1,33 + S/1049)
217-6	NHN	18.96 + 0.03 · S	0.123 + 0.00014 · S	1/(1/1,52 + S/1413)
	-	-	-	-
	MCHCM	33.11 + 0.03 · S	0.245 + 0.00014 · S	1/(1/1,63 + S/1413)
251-6	NHN	29.54 + 0.042 · S	0.253 + 0.00025 · S	1/(1/2,05 + S/2505)
	-	-	-	-
	MCHCM	53 + 0.042 · S	0.516 + 0.00025 · S	1/(1/2,18 + S/2505)
	MFHFM	97.57 + 0.042 · S	1.374 + 0.00025 · S	1/(1/2,18 + S/2505)
268-6	NHN	41.38 + 0.043 · S	0.41 + 0.00028 · S	1/(1/2,52 + S/2803)
	-	-	-	-
	MCHCM	68.56 + 0.043 · S	0.765 + 0.00028 · S	1/(1/2,69 + S/2803)
291-6	NHN	51.32 + 0.056 · S	0.598 + 0.00046 · S	1/(1/3,48 + S/4627)
	-	-	-	-
	MCHCM	82.87 + 0.056 · S	1.08 + 0.00046 · S	1/(1/3,67 + S/4627)
	MFHFM	171.4 + 0.056 · S	3.163 + 0.00046 · S	1/(1/3,67 + S/4627)
318-6	NHN	67.86 + 0.074 · S	0.936 + 0.00065 · S	1/(1/4,81 + S/6527)
	-	-	-	-
	MCHCM	115.6 + 0.074 · S	1.832 + 0.00065 · S	1/(1/5,2 + S/6527)
343-6	NHN	84.41 + 0.091 · S	1.332 + 0.001 · S	1/(1/5,07 + S/10323)
	-	-	-	-
	MCHCM	139.3 + 0.091 · S	2.556 + 0.001 · S	1/(1/5,33 + S/10323)
	MFHFM	255 + 0.091 · S	6.542 + 0.001 · S	1/(1/5,33 + S/10323)

LENGTH-DEPENDENT SPECIFICATIONS

of types NEN/ NHN, BEB, MCECM/MCHCM and MFEFM/MFHFM

Variant with E spacer

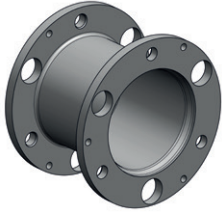

Variant with H spacer

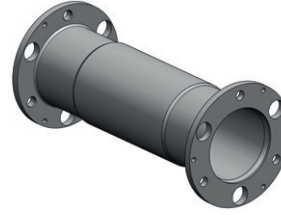

6

Size DA	Type	m kg	J kgm ²	C MNm/rad
219-8	NEN	28.17 + 0.027 · S	0.177 + 0.000089 · S	1/(1/3,98 + S/889)
	MCECM	44.48 + 0.027 · S	0.338 + 0.000089 · S	1/(1/6,11 + S/889)
	MFEFM	71.89 + 0.027 · S	0.703 + 0.000089 · S	1/(1/6,11 + S/889)
241-8	NEN	36.79 + 0.032 · S	0.276 + 0.00013 · S	1/(1/4,69 + S/1264)
	MCECM	61.04 + 0.032 · S	0.56 + 0.00013 · S	1/(1/6,74 + S/1264)
	MFEFM	91.45 + 0.032 · S	1.074 + 0.00013 · S	1/(1/6,74 + S/1264)
262-8	NEN	46.53 + 0.04 · S	0.414 + 0.00019 · S	1/(1/5,4 + S/1884)
	MCECM	78.23 + 0.04 · S	0.846 + 0.00019 · S	1/(1/7,22 + S/1884)
	MFEFM	120.1 + 0.04 · S	1.692 + 0.00019 · S	1/(1/7,22 + S/1884)
285-8	NEN	61.59 + 0.051 · S	0.656 + 0.00028 · S	1/(1/7,04 + S/2836)
	MCECM	100.8 + 0.051 · S	1.315 + 0.00028 · S	1/(1/9,31 + S/2836)
	MFEFM	155 + 0.051 · S	2.552 + 0.00028 · S	1/(1/9,31 + S/2836)
302-8	NEN	78.21 + 0.062 · S	0.948 + 0.00039 · S	1/(1/9,87 + S/3948)
	MCECM	122.3 + 0.062 · S	1.774 + 0.00039 · S	1/(1/13,4 + S/3948)
	MFEFM	182 + 0.062 · S	3.359 + 0.00039 · S	1/(1/13,4 + S/3948)
321-8	NEN	96.07 + 0.066 · S	1.317 + 0.0005 · S	1/(1/13,9 + S/5053)
	MCECM	150 + 0.066 · S	2.469 + 0.0005 · S	1/(1/20,1 + S/5053)
	MFEFM	216.6 + 0.066 · S	4.48 + 0.0005 · S	1/(1/20,1 + S/5053)
354-8	NEN	129.1 + 0.079 · S	2.163 + 0.00079 · S	1/(1/18,2 + S/7977)
	MCECM	191.4 + 0.079 · S	3.866 + 0.00079 · S	1/(1/24,7 + S/7977)
	MFEFM	286.5 + 0.079 · S	7.246 + 0.00079 · S	1/(1/24,7 + S/7977)
387-8	NEN	169.6 + 0.093 · S	3.414 + 0.0012 · S	1/(1/25,3 + S/11742)
	MCECM	242.5 + 0.093 · S	5.88 + 0.0012 · S	1/(1/31,5 + S/11742)
	MFEFM	351.7 + 0.093 · S	10.62 + 0.0012 · S	1/(1/31,5 + S/11742)
411-8	NEN	201.9 + 0.113 · S	4.565 + 0.0015 · S	1/(1/29,4 + S/15183)
	MCECM	287.1 + 0.113 · S	7.821 + 0.0015 · S	1/(1/36 + S/15183)
	MFEFM	415.8 + 0.113 · S	14.1 + 0.0015 · S	1/(1/36 + S/15183)
447-8	NEN	260.7 + 0.129 · S	6.985 + 0.0021 · S	1/(1/38 + S/21062)
	MCECM	367.1 + 0.129 · S	11.74 + 0.0021 · S	1/(1/46,5 + S/21062)
	MFEFM	534.1 + 0.129 · S	21.22 + 0.0021 · S	1/(1/46,5 + S/21062)
495-8	NEN	354.4 + 0.157 · S	11.61 + 0.0033 · S	1/(1/46,4 + S/33418)
	MCECM	497.5 + 0.157 · S	19.74 + 0.0033 · S	1/(1/54,5 + S/33418)
	MFEFM	693.8 + 0.157 · S	33.95 + 0.0033 · S	1/(1/54,5 + S/33418)
546-8	NEN	483.3 + 0.212 · S	19.43 + 0.0056 · S	1/(1/59 + S/56448)
	MCECM	663.8 + 0.212 · S	32.27 + 0.0056 · S	1/(1/67 + S/56448)
	MFEFM	923.1 + 0.212 · S	55.39 + 0.0056 · S	1/(1/67 + S/56448)
587-8	NEN	600.7 + 0.279 · S	27.94 + 0.0076 · S	1/(1/67,3 + S/76570)
	MCECM	821.9 + 0.279 · S	45.85 + 0.0076 · S	1/(1/75,3 + S/76570)
	MFEFM	1147 + 0.279 · S	79.25 + 0.0076 · S	1/(1/75,3 + S/76570)
631-8	NEN	731.9 + 0.302 · S	39.04 + 0.01 · S	1/(1/79,6 + S/102143)
	MCECM	1006 + 0.302 · S	64.52 + 0.01 · S	1/(1/88,2 + S/102143)
	MFEFM	1441 + 0.302 · S	114.7 + 0.01 · S	1/(1/88,2 + S/102143)

Size DA	Type	m kg	J kgm ²	C MNm/rad
219-8	NHN	26.88 + 0.035 · S	0.172 + 0.00012 · S	1/(1/3,35 + S/1176)
	MCHCM	42.52 + 0.035 · S	0.33 + 0.00012 · S	1/(1/4,3 + S/1176)
	MFHFM	69.94 + 0.035 · S	0.695 + 0.00012 · S	1/(1/4,3 + S/1176)
241-8	NHN	34.62 + 0.044 · S	0.266 + 0.00018 · S	1/(1/3,88 + S/1760)
	MCHCM	57.91 + 0.044 · S	0.546 + 0.00018 · S	1/(1/4,73 + S/1760)
	MFHFM	88.32 + 0.044 · S	1.06 + 0.00018 · S	1/(1/4,73 + S/1760)
262-8	NHN	44.21 + 0.054 · S	0.402 + 0.00025 · S	1/(1/4,72 + S/2549)
	MCHCM	74.72 + 0.054 · S	0.828 + 0.00025 · S	1/(1/5,65 + S/2549)
	MFHFM	116.5 + 0.054 · S	1.673 + 0.00025 · S	1/(1/5,65 + S/2549)
285-8	NHN	59.68 + 0.064 · S	0.643 + 0.00035 · S	1/(1/6,46 + S/3534)
	MCHCM	97.63 + 0.064 · S	1.296 + 0.00035 · S	1/(1/7,87 + S/3534)
	MFHFM	151.8 + 0.064 · S	2.533 + 0.00035 · S	1/(1/7,87 + S/3534)
302-8	NHN	75.6 + 0.078 · S	0.928 + 0.00049 · S	1/(1/8,95 + S/4945)
	MCHCM	118.1 + 0.078 · S	1.744 + 0.00049 · S	1/(1/11,1 + S/4945)
	MFHFM	177.7 + 0.078 · S	3.329 + 0.00049 · S	1/(1/11,1 + S/4945)
321-8	NHN	92.41 + 0.086 · S	1.285 + 0.00065 · S	1/(1/12,2 + S/6577)
	MCHCM	144.2 + 0.086 · S	2.419 + 0.00065 · S	1/(1/15,4 + S/6577)
	MFHFM	210.8 + 0.086 · S	4.43 + 0.00065 · S	1/(1/15,4 + S/6577)
354-8	NHN	126 + 0.098 · S	2.129 + 0.00098 · S	1/(1/16,7 + S/9874)
	MCHCM	186 + 0.098 · S	3.809 + 0.00098 · S	1/(1/20,8 + S/9874)
	MFHFM	281.2 + 0.098 · S	7.189 + 0.00098 · S	1/(1/20,8 + S/9874)
387-8	NHN	164.5 + 0.122 · S	3.343 + 0.0015 · S	1/(1/22,8 + S/15253)
	MCHCM	234.9 + 0.122 · S	5.777 + 0.0015 · S	1/(1/26,4 + S/15253)
	MFHFM	344.1 + 0.122 · S	10.51 + 0.0015 · S	1/(1/26,4 + S/15253)
411-8	NHN	196.8 + 0.141 · S	4.49 + 0.0019 · S	1/(1/27,1 + S/18813)
	MCHCM	279.5 + 0.141 · S	7.712 + 0.0019 · S	1/(1/31,3 + S/18813)
	MFHFM	408.1 + 0.141 · S	13.99 + 0.0019 · S	1/(1/31,3 + S/18813)
447-8	NHN	255.1 + 0.157 · S	6.883 + 0.0026 · S	1/(1/35,1 + S/25615)
	MCHCM	358.7 + 0.157 · S	11.59 + 0.0026 · S	1/(1/40,9 + S/25615)
	MFHFM	525.6 + 0.157 · S	21.07 + 0.0026 · S	1/(1/40,9 + S/25615)
495-8	NHN	345 + 0.2 · S	11.39 + 0.0042 · S	1/(1/43 + S/42683)
	MCHCM	483.5 + 0.2 · S	19.42 + 0.0042 · S	1/(1/48,2 + S/42683)
	MFHFM	679.8 + 0.2 · S	33.62 + 0.0042 · S	1/(1/48,2 + S/42683)
546-8	NHN	474 + 0.255 · S	19.16 + 0.0068 · S	1/(1/56,3 + S/67807)
	MCHCM	649.6 + 0.255 · S	31.86 + 0.0068 · S	1/(1/62,2 + S/67807)
	MFHFM	908.9 + 0.255 · S	54.99 + 0.0068 · S	1/(1/62,2 + S/67807)
587-8	NHN	590 + 0.324 · S	27.6 + 0.0088 · S	1/(1/65 + S/88708)
	MCHCM	806 + 0.324 · S	45.37 + 0.0088 · S	1/(1/71,2 + S/88708)
	MFHFM	1131 + 0.324 · S	78.77 + 0.0088 · S	1/(1/71,2 + S/88708)
631-8	NHN	715.1 + 0.361 · S	38.39 + 0.012 · S	1/(1/76,3 + S/123294)
	MCHCM	981.7 + 0.361 · S	63.61 + 0.012 · S	1/(1/82,6 + S/123294)
	MFHFM	1417 + 0.361 · S	113.8 + 0.012 · S	1/(1/82,6 + S/123294)

Variant with E spacer

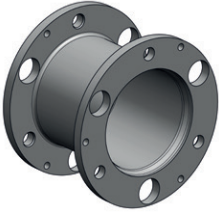

Size DA	Type	<i>m</i> kg	<i>J</i> kgm ²	<i>C</i> MNm/rad
495-10	NEN	355.1 + 0.157 · S	11.7 + 0.0033 · S	1/(1/113 + S/33418)
	MFEFM	693 + 0.157 · S	33.97 + 0.0033 · S	1/(1/176 + S/33418)
546-10	NEN	483.7 + 0.212 · S	19.56 + 0.0056 · S	1/(1/138 + S/56448)
	MFEFM	921.8 + 0.212 · S	55.43 + 0.0056 · S	1/(1/190 + S/56448)
587-10	NEN	600.5 + 0.279 · S	28.09 + 0.0076 · S	1/(1/165 + S/76570)
	MFEFM	1145 + 0.279 · S	79.29 + 0.0076 · S	1/(1/223 + S/76570)
631-10	NEN	731.3 + 0.302 · S	39.23 + 0.01 · S	1/(1/187 + S/102143)
	MFEFM	1438 + 0.302 · S	114.8 + 0.01 · S	1/(1/241 + S/102143)
694-10	NEN	1057 + 0.39 · S	69.77 + 0.015 · S	1/(1/293 + S/154224)
	MFEFM	1950 + 0.39 · S	188.1 + 0.015 · S	1/(1/412 + S/154224)
734-10	NEN	1265 + 0.45 · S	94.03 + 0.02 · S	1/(1/373 + S/196935)
	MFEFM	2314 + 0.45 · S	248.7 + 0.02 · S	1/(1/542 + S/196935)
790-10	NEN	1587 + 0.53 · S	136.9 + 0.027 · S	1/(1/467 + S/270335)
	MFEFM	2919 + 0.53 · S	363.4 + 0.027 · S	1/(1/677 + S/270335)
887-10	NEN	2335 + 0.687 · S	256 + 0.042 · S	1/(1/644 + S/418343)
	MFEFM	4197 + 0.687 · S	665.8 + 0.042 · S	1/(1/944 + S/418343)
988-10	NEN	3264 + 0.975 · S	447.8 + 0.067 · S	1/(1/856 + S/675886)
	MFEFM	5736 + 0.975 · S	1129 + 0.067 · S	1/(1/1229 + S/675886)

Variant with H spacer

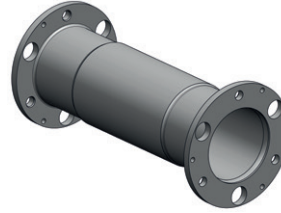

Size DA	Type	<i>m</i> kg	<i>J</i> kgm ²	<i>C</i> MNm/rad
495-10	NHN	345.7 + 0.2 · S	11.47 + 0.0042 · S	1/(1/94,7 + S/42683)
	MFHFM	678.9 + 0.2 · S	33.65 + 0.0042 · S	1/(1/124 + S/42683)
546-10	NHN	474.4 + 0.255 · S	19.28 + 0.0068 · S	1/(1/124 + S/67807)
	MFHFM	907.5 + 0.255 · S	55.03 + 0.0068 · S	1/(1/156 + S/67807)
587-10	NHN	589.9 + 0.324 · S	27.76 + 0.0088 · S	1/(1/152 + S/88708)
	MFHFM	1129 + 0.324 · S	78.81 + 0.0088 · S	1/(1/191 + S/88708)
631-10	NHN	714.5 + 0.361 · S	38.57 + 0.012 · S	1/(1/169 + S/123294)
	MFHFM	1414 + 0.361 · S	113.9 + 0.012 · S	1/(1/204 + S/123294)
694-10	NHN	1028 + 0.487 · S	68.47 + 0.019 · S	1/(1/257 + S/193881)
	MFHFM	1906 + 0.487 · S	186.2 + 0.019 · S	1/(1/322 + S/193881)
734-10	NHN	1229 + 0.563 · S	92.27 + 0.025 · S	1/(1/325 + S/247708)
	MFHFM	2260 + 0.563 · S	246.1 + 0.025 · S	1/(1/414 + S/247708)
790-10	NHN	1544 + 0.663 · S	134.4 + 0.034 · S	1/(1/409 + S/340076)
	MFHFM	2852 + 0.663 · S	359.6 + 0.034 · S	1/(1/522 + S/340076)
887-10	NHN	2278 + 0.844 · S	252 + 0.051 · S	1/(1/568 + S/517255)
	MFHFM	4107 + 0.844 · S	659.8 + 0.051 · S	1/(1/734 + S/517255)
988-10	NHN	3192 + 1.154 · S	441.8 + 0.08 · S	1/(1/774 + S/807126)
	MFHFM	5620 + 1.154 · S	1120 + 0.08 · S	1/(1/1006 + S/807126)

OTHER DESIGN OPTIONS

6



Flange version for adaptation to a customer flange



Intermediate spacer as a torsion shaft for reducing the torsional stiffness

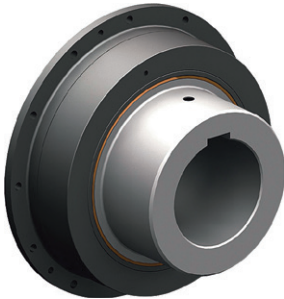

Slipping flanges for overload protection against brief high-frequency torque shock loads

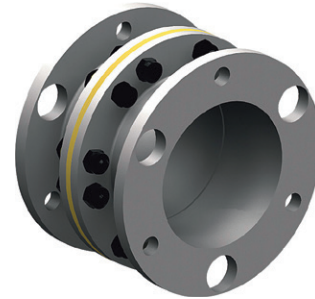

Version for avoiding leakage currents between the connected units



Slipping hubs for overload protection against brief high-frequency torque shock loads



Vertical support for avoiding excessive axial loading of the plate packs by the weight of the intermediate spacer

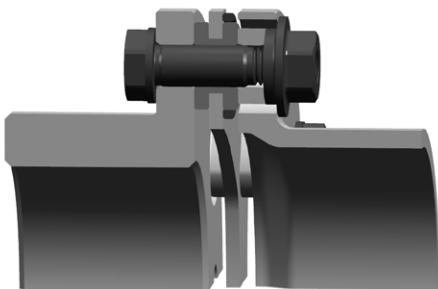

Axial backlash limiter



Brake disk/brake drum

GENERAL

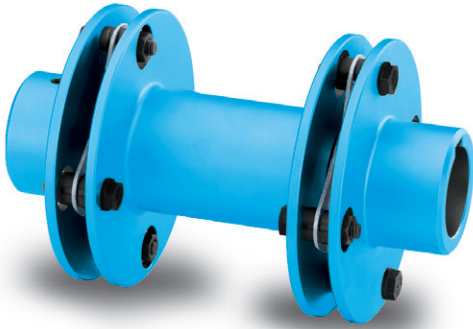

Coupling suitable for use in potentially explosive atmospheres.

Complies with the current ATEX Directive for:

CE  II 2G Ex h IIC T6 ... T2 Gb X

 II 2D Ex h IIIC T85 °C ... 250 °C Db X

 I M2 Ex h Mb X

Benefits

ARPEX couplings of the ARW-4/-6 series are outstanding for their large angular misalignment capacity of 3°. They were specially designed for drives where high misalign-

ments which have to be compensated for by the coupling are to be expected. The intermediate spacer lengths are variable and are manufactured to customer specifications.

Application

ARPEX couplings of the ARW-4/-6 series are used where large misalignment capacities are required. In the paper-making machine industry, the ARW coupling has already proved itself as a maintenance-free alternative to the cardan shaft. Torques of between 92 and 80000 Nm can be transmitted at a permitted angular misalignment of 3.0°. The intermediate spacer can be fitted radially without moving the connected units.

Main areas of application for the ARW-4/-6 series:

- Paper-making machines
- Wind power systems
- Traction drives

GENERAL

Design and configurations

The design of an ARPEX NHN coupling of the ARW-4/-6 series is shown in the following illustration. The plate packs are bolted alternately between the flanges of the coupling hubs and the intermediate spacer. Up to size 292-4 close-fitting bolts and from size 324-4 conical screw connections are used for fastening.

Up to size 647-4 plate packs in rectangular design, from size 695-6 in hexagonal design are used. The intermediate spacers are variable in length and are manufactured specifically to customer specifications.

6

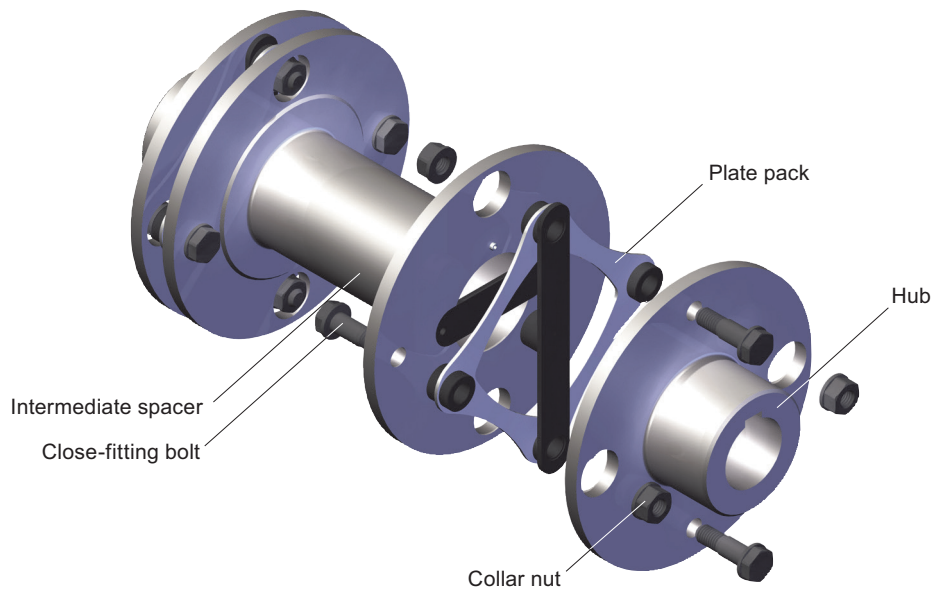

G_MD10_EN_00163a

Variants of the ARPEX coupling, ARW-4/-6 series

Variants of the ARPEX coupling, ARW-4/-6 series

Type	Description
NHN	Variant with unmachined intermediate spacer, with variable spacer length

The article number can be obtained with the help of the Configurator. The coupling can be selected in a product configurator and specified using selection menus.

The Configurator is available under flender.com

The coupling can be selected via "Technical selection" (technical selection) or via "Direct selection" (via article no.).

The coupling parts of the ARPEX ARW-4/-6 series with the exception of H spacers are machined on all sides. These are delivered with unmachined, primed spacer tube.

Technical specifications

Power ratings										
Size	Rated torque	Maximum torque	Overload torque	Fatigue torque	Maximum speed	Maximum permitted shaft misalignment				Torsional stiffness
	T_{KN}	T_{Kmax}	T_{KOL}	T_{KW}	n_{Kmax}	+ ΔK_a	- ΔK_a	$\pm \Delta K_w$	$\pm \Delta K_r$	C_{Tdyn}
	Nm	Nm	Nm	Nm	rpm	Tension	Compression		mm	MNm/rad
									for S = 1000 mm	for S = 1000 mm
101-4	92	140	230	37	10400	2.4	2		51.8	0.006
133-4	225	340	560	90	7850	3.3	2.2		51.7	0.012
167-4	450	680	1130	180	6250	4.2	2.2		51.6	0.028
196-4	800	1200	2000	320	5350	5.1	2.2		51.6	0.068
230-4	1250	1880	3200	500	4550	5.7	2.2		51.6	0.108
260-4	2000	3000	5000	800	4000	6.6	2.2		51.5	0.174
292-4	2700	4100	6800	1080	3550	7.5	2.8		51.4	0.275
324-4	3850	5800	9700	1540	3200	8.4	2.8		51.4	0.451
355-4	5250	7900	13200	2100	2950	9	2.8		51.4	0.622
389-4	6650	10000	16700	2660	2700	10	2.8	3.0°	51.4	0.657
439-4	9850	15000	25000	3940	2350	11.1	3		51.3	1.08
499-4	13300	20000	34000	5320	2100	12.4	4.8		50.8	1.32
547-4	19000	29000	48000	7600	1900	13.4	4.8		50.7	2.03
600-4	25150	38000	63000	10060	1750	14.6	4.8		50.6	2.73
647-4	32500	49000	82000	13000	1600	16	4.8		50.6	3.93
695-6	41000	62000	103000	16400	1500	17	4.8		50.7	10.1
756-6	52000	78000	130000	20800	1350	18	4.8		50.6	14
817-6	65000	98000	163000	26000	1250	20	4.8		50.5	16.9
880-6	80000	120000	200000	32000	1150	22	4.8		50.5	21.2

The radial misalignment ΔK_r applies to a type NHN coupling with a shaft distance $S = 1000$ mm. The radial misalignment ΔK_r for other shaft distances S is calculated as follows: $\Delta K_r = [S - S1] \cdot \tan(\Delta K_w)$

The permitted shaft misalignments ΔK_a , ΔK_r and ΔK_w are maximum values and must not occur at the same time (see following table).

The torsional stiffness values apply to the entire coupling with shaft distance $S = 1000$ mm. The torsional stiffness of the plate packs applies to the rated coupling torque T_{KN} . To determine the torsional stiffness for a specific operating point, e.g. for calculating torsional vibration, the manufacturer must be consulted.

- T_{Kmax} permitted only five times per hour.
- T_{KW} for medium torque $T_N = 0$ Nm.
- If T_N and T_{KW} occur at the same time, the manufacturer must be consulted.

GENERAL

6

Permitted shaft misalignments						
Size	Permitted angular misalignment ΔK_w (tension +)			Permitted angular misalignment ΔK_w (compression -)		
	3.0 °	1.5 °	0.0 °	3.0 °	1.5 °	0.0 °
	Permitted axial misalignment ΔK_a in mm			Permitted axial misalignment ΔK_a in mm		
101-4	0.8	1.6	2.4	0.8	1.6	2
133-4	1.1	2.2	3.3	1.1	2.2	2.2
167-4	1.4	2.8	4.2	1.4	2.2	2.2
196-4	1.7	3.4	5.1	1.7	2.2	2.2
230-4	1.9	3.8	5.7	1.9	2.2	2.2
260-4	2.2	4.4	6.6	2.2	2.2	2.2
292-4	2.5	5	7.5	2.5	2.8	2.8
324-4	2.8	5.6	8.4	2.8	2.8	2.8
355-4	3	6	9	2.8	2.8	2.8
389-4	3.3	6.7	10	2.8	2.8	2.8
439-4	3.7	7.4	11.1	3	3	3
499-4	4.1	8.3	12.4	4.1	4.8	4.8
547-4	4.5	8.9	13.4	4.4	4.8	4.8
600-4	4.9	9.7	14.6	4.8	4.8	4.8
647-4	5.3	10.7	16	4.8	4.8	4.8
695-6	5.6	11.4	17	4.8	4.8	4.8
756-6	6	12.1	18	4.8	4.8	4.8
817-6	6.7	13.4	20	4.8	4.8	4.8
880-6	7.3	14.8	22	4.8	4.8	4.8

Because of design specifications, the maximum possible axial shaft misalignment with plate packs pulled apart (**tension +**) is greater than with plate packs pressed together (**compression -**).

TYPE NHN

Torsionally rigid type NHN coupling with high angular misalignment capacity up to 3° and radially freely dismountable intermediate spacer and variable shaft distance S.

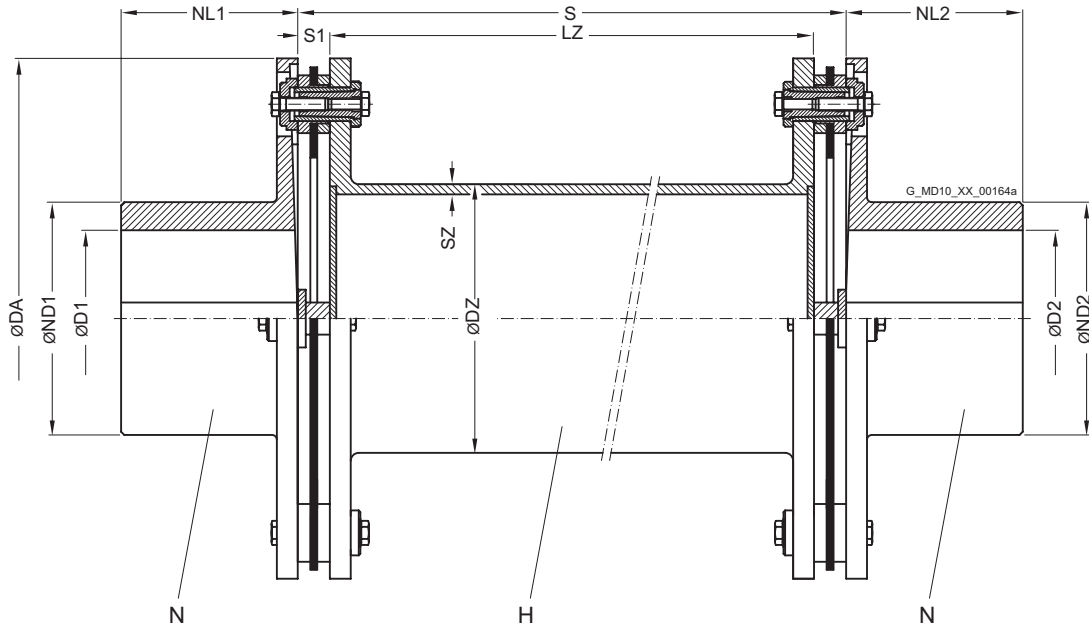

Size DA	Rated torque T_{KN}	Maximum speed n_{Kmax}	Dimensions in mm								Mass moment of inertia J	Article no. ¹⁾	Weight m
			D1, D2 Keyway DIN 6885 max.	ND1/ ND2	DZ	SZ	NL1/ NL2	S1	LZ	Shaft distance S			
mm	Nm	rpm									kgm ²		kg
101-4	92	10400	32	45	45	2.9	32	11	43	65	0.002	2LC0530-0AD	1.5
133-4	225	7850	45	60	48	2.9	45	13	59	85	0.008	2LC0530-1AD	3.9
167-4	450	6250	50	70	64	4	50	15	70	100	0.022	2LC0530-2AD	7.1
196-4	800	5350	60	80	89	4	60	16	83	115	0.056	2LC0530-3AD	12.1
230-4	1250	4550	75	100	102	5	75	16	83	115	0.109	2LC0530-4AD	17.9
260-4	2000	4000	90	120	133	5	90	17	96	130	0.189	2LC0530-5AD	24.6
292-4	2700	3550	100	130	152	5	100	19	92	130	0.359	2LC0530-6AD	35.1
324-4	3850	3200	110	145	168	6.3	110	20	120	160	0.52	2LC0530-7AD	43.7
355-4	5250	2950	120	160	178	7.1	120	20	125	165	0.856	2LC0530-8AD	59.8
389-4	6650	2700	130	175	194	7.1	130	20	130	170	1.09	2LC0531-0AD	68.9
439-4	9850	2350	150	200	219	7.1	150	22	166	210	2.23	2LC0531-1AD	106
499-4	13300	2100	165	220	245	7.1	165	30	170	230	3.81	2LC0531-2AD	142
547-4	19000	1900	190	250	299	8.8	190	32	176	240	6.24	2LC0531-3AD	191
600-4	25150	1750	205	275	324	8.8	205	34	182	250	10.2	2LC0531-4AD	257
647-4	32500	1600	225	300	343	10	225	35	220	290	16.5	2LC0531-5AD	348
695-6	41000	1500	240	325	368	10	240	33	224	290	23.7	2LC0540-0AD	441
756-6	52000	1350	255	340	394	12.5	255	34	232	300	33.2	2LC0540-1AD	525
817-6	65000	1250	270	360	406	12.5	270	36	238	310	49.1	2LC0540-2AD	659
880-6	80000	1150	300	400	419	12.5	300	37	256	330	72.8	2LC0540-3AD	849

Configurable variants ¹⁾

- ØD1 Without finished bore
With finished bore
- ØD2 Without finished bore
With finished bore

¹⁾ To identify complete item numbers specifying the available finish boring options and – if necessary – further order options, please use our configurators on flender.com.

➤ For online configuration on flender.com, click on the item no.

TYPE NHN

Permitted shaft distance S of type NHN relative to speed

Size DA mm	Speed n_N rpm												
	500	600	700	800	900	1000	1200	1400	1500	2000	2500	3000	4000
	Permitted shaft distance S in mm												
101-4	2822	2577	2387	2233	2106	1999	1825	1691	1634	1416	1268	1159	1005
133-4	2949	2693	2494	2334	2201	2089	1908	1767	1708	1481	1326	1212	1051
167-4	3376	3083	2856	2672	2520	2392	2185	2024	1956	1696	1518	1387	1203
196-4	4029	3679	3407	3188	3007	2854	2606	2414	2333	2022	1811	1654	1435
230-4	4297	3924	3634	3400	3207	3043	2779	2574	2488	2156	1930	1764	1530
260-4	4943	4514	4181	3912	3689	3500	3197	2961	2861	2480	2220	2028	1759
292-4	5305	4844	4487	4198	3959	3757	3431	3178	3071	2662	2383	2177	
324-4	5562	5079	4704	4401	4151	3939	3597	3332	3220	2791	2499	2283	
355-4	5709	5214	4828	4518	4261	4043	3692	3420	3305	2865	2564		
389-4	5968	5450	5047	4722	4453	4226	3859	3575	3454	2994	2680		
439-4	6361	5809	5380	5034	4747	4505	4114	3811	3682	3192			
499-4	6738	6154	5699	5333	5030	4773	4360	4039	3903	3384			
547-4	7442	6797	6295	5890	5555	5272	4815	4460	4310				
600-4	7762	7089	6565	6144	5794	5499	5022	4652	4496				
647-4	7980	7287	6750	6316	5957	5653	5163	4783	4622				
695-6	8000	7553	6995	6545	6173	5858	5350	4956	4789				
756-6	8000	7797	7221	6757	6372	6047	5523						
817-6	8000	7920	7335	6864	6473	6143	5611						
880-6	8000	8000	7456	6977	6580	6244							

Outside the permitted speed range

Notes

- The permitted length of the intermediate spacer depends on the maximum operating speed of the coupling. In the case of individual order of the intermediate spacer, the length (LZ) must be specified.
- Mass moments of inertia and weights apply to the entire NHN coupling with maximum bores D1/D2 and a shaft distance $S = S_{min}$.

Ordering example

- ARPEX ARW-4 NHN coupling, size 133-4, with shaft distance $S = 1000$ mm,
- Bore $\varnothing D1$ 40H7 mm, with keyway to DIN 6885 and set screw
- Bore $\varnothing D2$ 45K7 mm, with keyway to DIN 6885 and set screw

Article no.: 2LC0530-1AD99-0AZ0-Z L0W+M1A+Q0Y+M13
 Plain text to Q0Y: $S = 1000$ mm

¹⁾ To identify complete item numbers specifying the available finish boring options and – if necessary – further order options, please use our configurators on [flender.com](https://www.flender.com).

↗ For online configuration on [flender.com](https://www.flender.com), click on the item no.

SPARE AND WEAR PARTS

Plate pack, ARW-4/-6 series

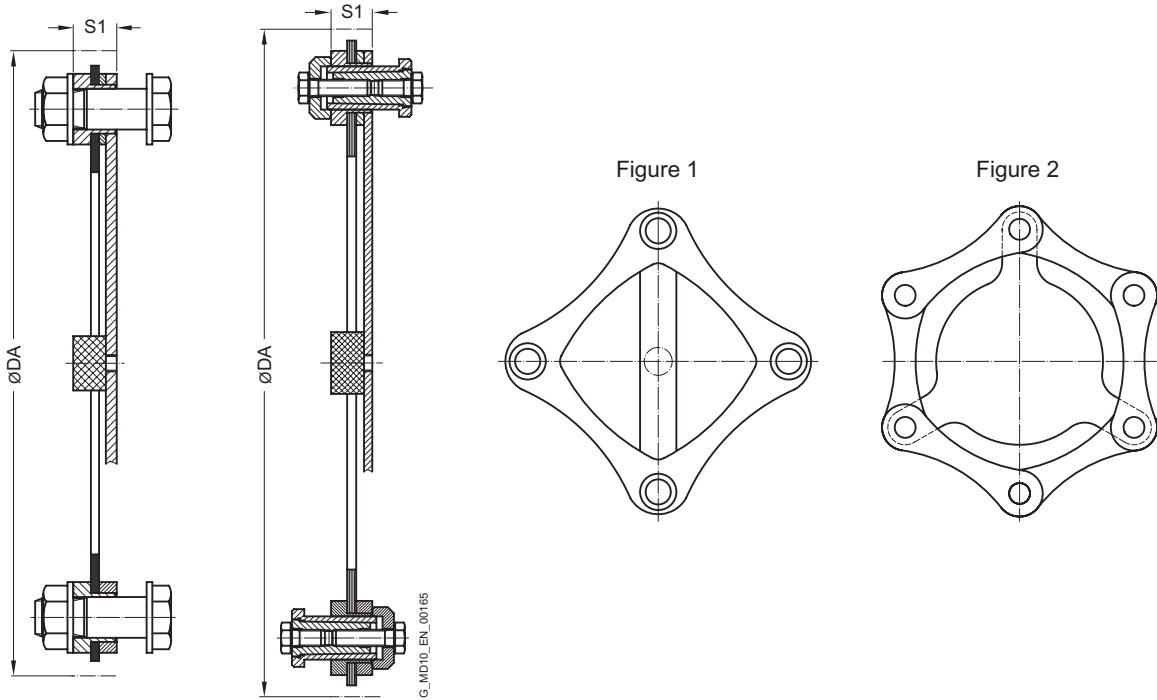

Size DA mm	Dimensions S1 mm	Mass moment of inertia J kgm ²	Article No.	Weight m kg
101-4	11	0.0001	2LC0530-0AB00-0AA0	0.1
133-4	13	0.0005	2LC0530-1AB00-0AA0	0.2
167-4	15	0.0017	2LC0530-2AB00-0AA0	0.5
196-4	16	0.0037	2LC0530-3AB00-0AA0	0.7
230-4	16	0.0068	2LC0530-4AB00-0AA0	1
260-4	17	0.0136	2LC0530-5AB00-0AA0	1.5
292-4	19	0.0227	2LC0530-6AB00-0AA0	1.9
324-4	20	0.0288	2LC0530-7AB00-0AA0	2.1
355-4	20	0.0452	2LC0530-8AB00-0AA0	2.7
389-4	20	0.0645	2LC0531-0AB00-0AA0	3.2
439-4	22	0.1147	2LC0531-1AB00-0AA0	4.5
499-4	30	0.2235	2LC0531-2AB00-0AA0	6.9
547-4	32	0.3658	2LC0531-3AB00-0AA0	9.5
600-4	34	0.5355	2LC0531-4AB00-0AA0	11.4
647-4	35	0.7939	2LC0531-5AB00-0AA0	14.6
695-6	33	1.4624	2LC0540-0AB00-0AA0	24.6
756-6	34	1.225	2LC0540-1AB00-0AA0	20.2
817-6	36	1.7497	2LC0540-2AB00-0AA0	23.9
880-6	37	2.546	2LC0540-3AB00-0AA0	28.9

Notes

- Plate packs of the ARW-4 series comprise ring plates (Fig. 1), those of the ARW-6 series side-bar plates (Fig. 2).
- The plate pack of the ARW-4/-6 series is readily available as a spare part.
- The plate pack is delivered with screw connection.
- Up to size 292-4 close-fitting bolts with collar nuts, from size 324-4 conical screw connections are used.

Ordering example

- ARPEX ARW-4 plate pack, size 133-4, complete with screw connection.



Article no.: 2LC0530-1AB00-0AA0

GENERAL



Coupling suitable for use in potentially explosive atmospheres.

Complies with the current ATEX Directive for:

- CE  II 2G Ex h IIC T6 ... T2 Gb X
-  II 2D Ex h IIIC T85 °C ... 250 °C Db X
-  I M2 Ex h Mb X

Benefits

ARPEX couplings of the ARF-6 series are extremely short and so suitable for drives with short shaft distances. They also serve as self-aligning couplings for axial, angular and radial misalignment. The hubs are available both as pure clamping hubs for smooth shafts and with parallel keyway

for shafts with parallel key.

The variant with slit clamping hubs enables the delivery of fully preassembled couplings. This means that the entire coupling can be dismantled and fitted without moving the connected units.

Application

ARPEX couplings of the ARF-6 series are designed for minimum fitting spaces without having to sacrifice the advantages of the two-joint coupling. It is thus possible to compensate for both axial and angular as well as radial misalignment. By using half-shell clamping hubs, the coupling can be radially freely dismantled. Power is transmitted via hexagon socket head cap screws and close-fitting bolts with nuts and ring plate packs in hexagonal design. Torques of between 120 and 6100 Nm can be transmitted at a permitted angular misalignment of 0.7°.

Main areas of application for the ARF-6 series:

- Film stretching machines
- Machines in the cellulose industry
- Machines in confined fitting situations

Design and configurations

The two plate packs form a unit with the adapter disk and are screwed together with close-fitting bolts and nuts at three points. The alternate connection of this intermediate unit with the flanges of the split coupling hubs is achieved by means of short hexagon socket head cap screws at further three points. The hubs are designed as axially slit

clamping hubs with a half-shell. For larger bores these can be manufactured as jumbo hubs. Optionally, the hubs are also available without parallel keyway.

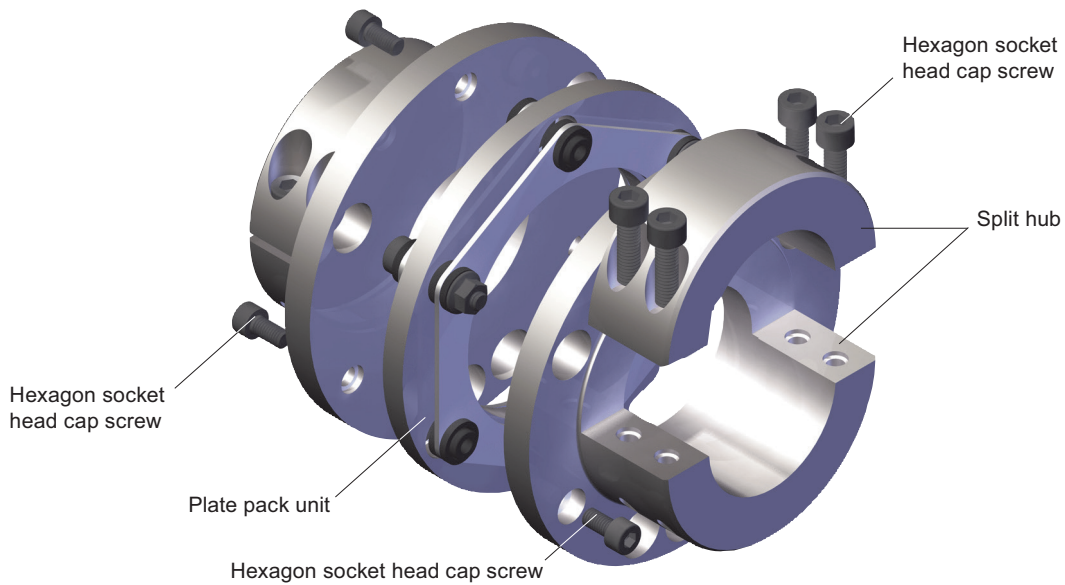

Design of the ARPEX coupling, ARF series

Variants of the ARF coupling

Type	Description
GG	Variant with 2 standard clamping hubs
GJ	Variant with 1 jumbo clamping hub for large bore diameters

The article number can be obtained with the help of the Configurator. The coupling can be selected in a product configurator and specified using selection menus.

The Configurator is available under [flender.com](https://www.flender.com)

The coupling can be selected via "Technical selection" (technical selection) or via "Direct selection" (via article no.).

GENERAL

Technical specifications

Power ratings, types GG and GJ									
Size	Rated torque	Maximum torque	Overload torque	Fatigue torque	Maximum speed	Maximum permitted shaft misalignment			Torsional stiffness
	T_{KN} Nm	T_{Kmax} Nm	T_{KOL} Nm	T_{KW} Nm	n_{Kmax} rpm	$\pm\Delta K_a$ mm	$\pm\Delta K_w$	$\pm\Delta K_r$ mm	C_T MNm/rad
84-6	120	220	330	55	12500	1.1		0.16	0.07
111-6	190	350	520	90	9450	1.8		0.16	0.13
132-6	350	650	950	160	7950	2.02		0.2	0.2
147-6	500	900	1350	230	7100	2.4		0.2	0.28
171-6	900	1700	2450	400	6100	2.74	0.7 °	0.24	0.57
182-6	1450	2600	4000	650	5750	2.86		0.29	0.66
202-6	2150	3900	5800	980	5200	3.06		0.29	0.77
218-6	3200	5800	8700	1450	4800	3.14		0.37	1.25
252-6	4500	8100	12000	2000	4150	3.7		0.45	1.55
267-6	6100	11000	16500	2800	3900	3.84		0.46	1.8

The permitted shaft misalignments ΔK_a , ΔK_r and ΔK_w are maximum values and must not occur at the same time (see following table).

- T_{Kmax} permitted only five times per hour.
- T_{KW} for medium torque $T_N = 0$ Nm.
- If T_N and T_{KW} occur at the same time, the manufacturer must be consulted.

The values for torsional stiffness apply to the complete coupling. The torsional stiffness of the plate packs applies to the rated coupling torque T_{KN} . To determine the torsional stiffness for a specific operating point, e.g. for calculating torsional vibration, the manufacturer must be consulted.

Permitted shaft misalignments								
Size	Permitted angular misalignment $\pm\Delta K_w$							
	0.0 °	0.1 °	0.2 °	0.3 °	0.4 °	0.5 °	0.6 °	0.7 °
	Permitted axial misalignment $\pm\Delta K_a$ in mm							
84-6	1.1	0.94	0.79	0.63	0.47	0.31	0.16	0
111-6	1.8	1.54	1.29	1.03	0.77	0.51	0.26	0
132-6	2.02	1.73	1.44	1.15	0.87	0.58	0.29	0
147-6	2.4	2.06	1.71	1.37	1.03	0.69	0.34	0
171-6	2.74	2.35	1.96	1.57	1.17	0.78	0.39	0
182-6	2.86	2.45	2.04	1.63	1.23	0.82	0.41	0
202-6	3.06	2.62	2.19	1.75	1.31	0.87	0.44	0
218-6	3.14	2.69	2.24	1.79	1.35	0.9	0.45	0
252-6	3.7	3.17	2.64	2.11	1.59	1.06	0.53	0
267-6	3.84	3.29	2.74	2.19	1.65	1.1	0.55	0

TYPES GG AND GJ

Radially freely dismountable, torsionally rigid coupling, available as types GG and GJ.

Complete dismounting without moving the units with extremely short shaft distances.

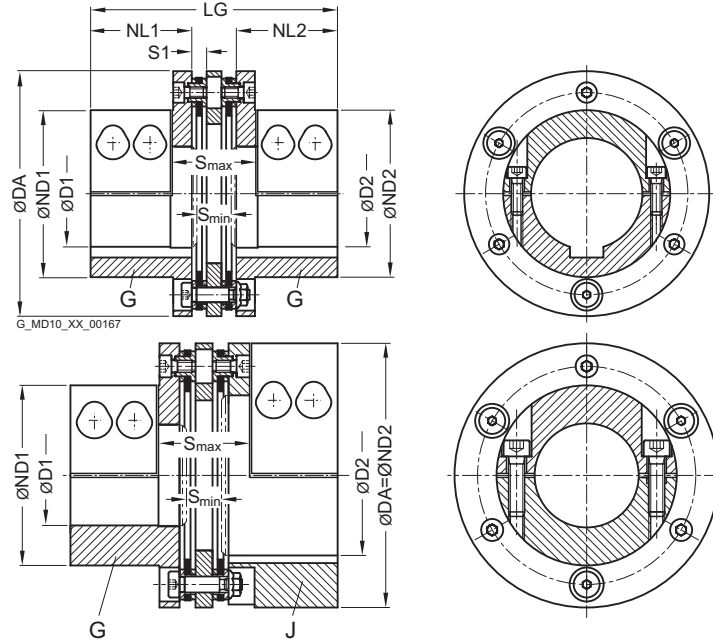

Size	Rated torque	Maximum speed	Type	Dimensions in mm									Mass moment of inertia J	Article no. ¹⁾	Weight	
DA	T_{KN}	n_{Kmax}		Keyway DIN 6885			ND1	ND2	NL1/NL2	S1	Shaft distance S		LG	kgm ²		m
mm	Nm	rpm		D1 max. Parallel key/ Clamping seat	D2 max. Parallel key	Clamping seat					min	max.		kgm ²		kg
84-6	120	12500	GG	25	25	25	50	50	40	6	16	39	99	0.0013	2LC0420-0AB99-0AA0	1.7
			GJ		40	48			84						0.0021	2LC0420-0AC99-0AA0
111-6	190	9450	GG	48	48	48	76	76	40	6	16	39	99	0.0043	2LC0420-1AB99-0AA0	2.9
			GJ		65	65			111						0.0067	2LC0420-1AC99-0AA0
132-6	350	7950	GG	52	52	52	90	90	55	8	18.5	45	134	0.011	2LC0420-2AB99-0AA0	5.7
			GJ		75	80			132						0.0177	2LC0420-2AC99-0AA0
147-6	500	7100	GG	60	60	60	105	105	65	8	18.5	45	154	0.0199	2LC0420-3AB99-0AA0	8.3
			GJ		85	85			147						0.0324	2LC0420-3AC99-0AA0
171-6	900	6100	GG	70	70	70	122	122	75	9	22.5	56	179	0.0439	2LC0420-4AB99-0AA0	13.3
			GJ		100	100			171						0.0695	2LC0420-4AC99-0AA0
182-6	1450	5750	GG	70	70	70	126	126	85	11	29	71	205	0.0649	2LC0420-5AB99-0AA0	17.5
			GJ		100	110			182						0.1005	2LC0420-5AC99-0AA0
202-6	2150	5200	GG	75	75	75	138	138	85	11	29	71	205	0.0986	2LC0420-6AB99-0AA0	21.9
			GJ		115	125			202						0.1519	2LC0420-6AC99-0AA0
218-6	3200	4800	GG	90	90	90	149	149	95	14	35	86	234	0.1499	2LC0420-7AB99-0AA0	27.2
			GJ		130	130			218						0.2345	2LC0420-7AC99-0AA0
252-6	4500	4150	GG	100	100	100	166	166	105	17	40.5	101	264	0.2924	2LC0420-8AB99-0AA0	39.9
			GJ		140	150			252						0.4651	2LC0420-8AC99-0AA0
267-6	6100	3900	GG	110	100	100	177	177	110	17	40.5	102	275	0.3827	2LC0421-0AB99-0AA0	45.9
			GJ		150	160			267						0.6129	2LC0421-0AC99-0AA0

¹⁾ To identify complete item numbers specifying the available finish boring options and – if necessary – further order options, please use our configurators on flender.com.

↗ For online configuration on flender.com, click on the item no.

TYPES GG AND GJ

Notes

- The shaft tolerance must be specified in the order.
To specify, "-Z" must be added to the article no. and the order codes "Y26" and "Y27" with plain text specification of the shaft tolerance for D1 and D2 must be added as well.
- Jumbo hubs for larger shaft diameters.
G and J hubs in split clamping hub variant.
The hub variant with keyway rates as standard. Optionally, the shaft/hub connection can be implemented without keyway as a pure clamping seat.
For specification of plate pack, see **Page 6/43**.
- Weights and mass moments of inertia apply to the entire coupling with maximum bores D1/D2.

Ordering example

- ARPEX ARF-6 GG coupling, size 132-6
- for shaft diameter ØD1 45h6 mm, without keyway
- for shaft diameter ØD2 50k6 mm,
with keyway to DIN 6885-1, keyway width P9.

Article no.: 2LC0420-2AB99-0AA0-Z L1A+M1C+L45+Y26+Y27

Plain text to Y26: h6

Plain text to Y27: k6

¹⁾ To identify complete item numbers specifying the available finish boring options and – if necessary – further order options, please use our configurators on [flender.com](https://www.flender.com).

➤ For online configuration on [flender.com](https://www.flender.com), click on the item no.

SPARE AND WEAR PARTS

Plate pack, ARF-6 series

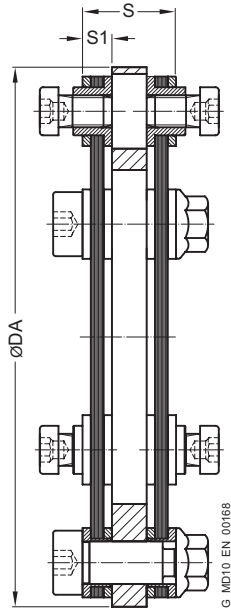
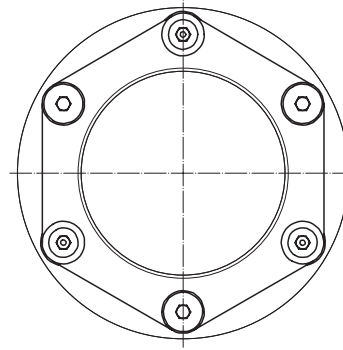

Figure 1



Size DA mm	Type	Dimensions		Mass moment of inertia J kgm ²	Article No.	Weight m kg
		S mm	S1 mm			
84-6	GG	19	6	0.0003	2LC0420-0AE00-0AA0	0.3
	GJ				2LC0420-0AH00-0AA0	
111-6	GG	19	6	0.0009	2LC0420-1AE00-0AA0	0.46
	GJ				2LC0420-1AH00-0AA0	
132-6	GG	24	8	0.0026	2LC0420-2AE00-0AA0	0.9
	GJ				2LC0420-2AH00-0AA0	
147-6	GG	24	8	0.0038	2LC0420-3AE00-0AA0	1.07
	GJ				2LC0420-3AH00-0AA0	
171-6	GG	29	9	0.0097	2LC0420-4AE00-0AA0	1.96
	GJ				2LC0420-4AH00-0AA0	
182-6	GG	35	11	0.0143	2LC0420-5AE00-0AA0	2.58
	GJ				2LC0420-5AH00-0AA0	
202-6	GG	35	11	0.024	2LC0420-6AE00-0AA0	3.53
	GJ				2LC0420-6AH00-0AA0	
218-6	GG	44	14	0.0383	2LC0420-7AE00-0AA0	4.89
	GJ				2LC0420-7AH00-0AA0	
252-6	GG	54	17	0.0812	2LC0420-8AE00-0AA0	7.9
	GJ				2LC0420-8AH00-0AA0	
267-6	GG	55	17	0.1152	2LC0421-0AE00-0AA0	9.6
	GJ				2LC0421-0AH00-0AA0	

Note

- Ring plates (Figure 1) are used for the plate packs.
- The plate pack unit for the ARF-6 series is readily available as a spare part in most sizes.
- The plate pack unit comprises two preassembled plate packs with adapter disk, including screw connection. The standard screw connection comprises hexagon socket head cap screws and close-fitting bolts with nuts.

APPENDIX

Fits	A/2
Fitting recommendations	A/2
Deviation table to DIN ISO 286	A/2
Cylindrical shaft ends, extract from DIN 748 Part 1 (long)	A/3
Central holes according to DIN 332 Part 2	A/3
Parallel key connections to DIN 6885-1	A/4
Related catalogs	A/6
Suitable gear solutions	A/8
The perfect coupling	A/10
Individual solutions	A/12
Flender Services	A/16

FITS

Fitting recommendations

For many applications, the fit assignment m6/H7 is especially suitable.

Description	Application	Shaft tolerance	Bore tolerance
Facile sliding fit	For steel or aluminum hubs Preferred for SIPEX and BIPEX-S coupling series	g6	H7
		h7	H7
		k6	F7
		m6	F7
Sliding fit with parallel key connection not suitable for reversing operation	For steel and cast hubs	j6	H7
		h6	J7
Press fit with parallel key connection not suitable for reversing operation	For steel and cast hubs	h6	K7
		k6	H7
Interference fit with parallel key connection suitable for reversing operation	For steel and cast hubs Only for steel hubs Preferred for ZAPEX and ARPEX coupling series	m6	H7
		n6	H7
		h6	M7
		h6	P7
		k6	M7
		m6	K7
		n6	J7
		p6	H7
Shrink fit connection without parallel key	Only for steel hubs The permitted hub tension must be urgently checked.	s6	F7
		u6	H6
		v6	H6
		x6	H6

Deviation table to DIN ISO 286 for above-mentioned fits for bore diameters from 10 mm to 250 mm

Bore diameter above	up to	Deviations in µm Bore						Shaft					
		F7	H7	J7	K7	M7	P7	h6	j6	k6	m6	n6	p6
10	18	+34	+18	+10	+6	0	-11	0	+8	+12	+18	+23	+29
		+16	0	-8	-12	-18	-29	-11	-3	+1	+7	+12	+18
18	30	+41	+21	+12	+6	0	-14	0	+9	+15	+21	+28	+35
		+20	0	-9	-15	-21	-35	-13	-4	+2	+8	+15	+22
30	50	+50	+25	+14	+7	0	-17	0	+11	+18	+25	+33	+42
		+25	0	-11	-18	-25	-42	-16	-5	+2	+9	+17	+26
50	80	+60	+30	+18	+9	0	-21	0	+12	+21	+30	+39	+51
		+30	0	-12	-21	-30	-51	-19	-7	+2	+11	+20	+32
80	120	+71	+35	+22	+10	0	-24	0	+13	+25	+35	+45	+59
		+36	0	-13	-25	-35	-59	-22	-9	+3	+13	+23	+37
120	180	+83	+40	+26	+12	0	-28	0	+14	+28	+40	+52	+68
		+43	0	-14	-28	-40	-68	-25	-11	+3	+15	+27	+43
180	250	+96	+46	+30	+13	0	-33	0	+16	+33	+46	+60	+79
		+50	0	-16	-33	-46	-79	-29	-13	+4	+17	+31	+50

A

Cylindrical shaft ends, extract from DIN 748 Part 1 (long)

	Diameter in mm																					
	24	25	28	30	32	35	38	40	42	45	48	50	55	60	65	70	75	80	85	90	95	100
ISO tolerance zone	k6												m6									
End length in mm	50	60	80	110							140					170				210		

Central holes according to DIN 332 Part 2

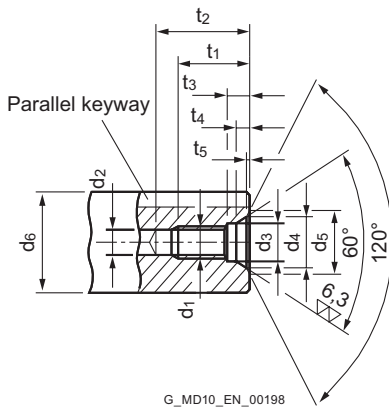

Form DS (with thread) DIN 332/2

Recommended diameter ranges d_6 ¹⁾		DS form dimensions									
above	up to	d_1	d_2 ²⁾	d_3	d_4	d_5	t_1 ₊₂	t_2 min.	t_3 ₊₁	t_4 approx.	t_5 approx.
7	10	M3	2.5	3.2	5.3	5.8	9	12	2.6	1.8	0.2
10	13	M4	3.3	4.3	6.7	7.4	10	14	3.2	2.1	0.3
13	16	M5	4.2	5.3	8.1	8.8	12.5	17	4	2.4	0.3
16	21	M6	5	6.4	9.6	10.5	16	21	5	2.8	0.4
21	24	M8	6.8	8.4	12.2	13.2	19	25	6	3.3	0.4
24	30	M10	8.5	10.5	14.9	16.3	22	30	7.5	3.8	0.6
30	38	M12	10.2	13	18.1	19.8	28	37	9.5	4.4	0.7
38	50	M16	14	17	23	25.3	36	45	12	5.2	1.0
50	85	M20	17.5	21	28.4	31.3	42	53	15	6.4	1.3
85	130	M24	21	25	34.2	38	50	63	18	8	1.6
130	225	M30 ³⁾	26.5	31	40.2	44.6	60	77	22	8	1.9
225	320	M36 ³⁾	32	37	49.7	55	74	93	22	11	2.3
320	500	M42 ³⁾	37.5	43	60.3	66.6	84	105	26	15	2.7

¹⁾ Diameter refers to the finished workpiece

²⁾ Tap hole drill diameter according to DIN 336 Part 1

³⁾ Dimensions not acc. to DIN 332 Part 2

PARALLEL KEY CONNECTIONS TO DIN 6885-1

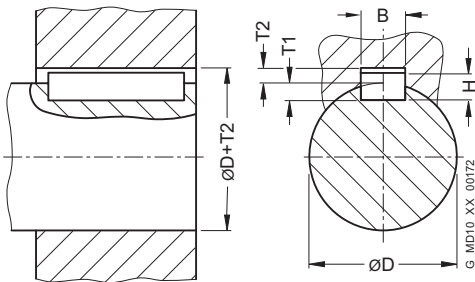

For moderate operating conditions, the hub keyway tolerance JS9 is recommended.

In harsh operating conditions or during reversing operation, the keyway width tolerance P9 must be preferred.

With two parallel keyways, the keyway width tolerance JS9 should be specified in order to simplify the assembly.

The shaft keyway width has to be specified with the tolerance N9.

Diameter above D mm	up to mm	Keyway width B mm	Parallel key height H mm	Shaft keyway depth T1 mm	Hub keyway depth T2 mm	Deviation for shaft and hub keyway depth mm	Deviation table for keyway width B	
							JS9 μm	P9 μm
	10	3	3	1.8	1.4	+0.1	+12.5 -12.5	-6 -31
10	12	4	4	2.5	1.8	+0.1	+15 -15	-12 -42
12	17	5	5	3	2.3	+0.1	+15 -15	-12 -42
17	22	6	6	3.5	2.8	+0.1	+15 -15	-12 -42
22	30	8	7	4	3.3	+0.2	+18 -18	-15 -51
30	38	10	8	5	3.3	+0.2	+18 -18	-15 -51
38	44	12	8	5	3.3	+0.2	+21.5 -21.5	-18 -61
44	50	14	9	5.5	3.8	+0.2	+21.5 -21.5	-18 -61
50	58	16	10	6	4.3	+0.2	+21.5 -21.5	-18 -61
58	65	18	11	7	4.4	+0.2	+21.5 -21.5	-18 -61
65	75	20	12	7.5	4.9	+0.2	+26 -26	-22 -74
75	85	22	14	9	5.4	+0.2	+26 -26	-22 -74
85	95	25	14	9	5.4	+0.2	+26 -26	-22 -74

Diameter		Keyway width B mm	Parallel key height H mm	Shaft keyway depth		Hub keyway depth T2 mm	Deviation for shaft and hub keyway depth mm	Deviation table for keyway width B	
above D mm	up to mm			T1 mm	T2 mm			JS9 µm	P9 µm
95	110	28	16	10	6.4	+0.2	+26 -26	-22 -74	
110	130	32	18	11	7.4	+0.2	+31 -31	-26 -88	
130	150	36	20	12	8.4	+0.3	+31 -31	-26 -88	
150	170	40	22	13	9.4	+0.3	+31 -31	-26 -88	
170	200	45	25	15	10.4	+0.3	+31 -31	-26 -88	
200	230	50	28	17	11.4	+0.3	+31 -31	-26 -88	
230	260	56	32	20	12.4	+0.3	+37 -37	-32 -106	
260	290	63	32	20	12.4	+0.3	+37 -37	-32 -106	
290	330	70	36	22	14.4	+0.3	+37 -37	-32 -106	
330	380	80	40	25	15.4	+0.3	+37 -37	-32 -106	
380	440	90	45	28	17.4	+0.3	+43.5 -43.5	-37 -124	
440	500	100	50	31	19.4	+0.3	+43.5 -43.5	-37 -124	



RELATED CATALOGS

Torsionally Rigid Couplings

FLE 10.1
FLEX-C10001-00-7600



Flexible Couplings

FLE 10.2
FLEX-C10002-00-7600



Highly Flexible Couplings

FLE 10.3
FLEX-C10003-00-7600



Fluid Couplings

FLE 10.4
FLEX-C10004-00-7600



ARPEX

High Performance Couplings
FLE 10.5
FLEX-C10120-00-7600



SIPEX und BIPEX-S

Backlash-free couplings
FLE 10.6
FLEX-C10121-00-7600



ARPEX

Safety couplings
FLE 10.7
FLEX-C10122-00-7600



FASTEX

Clamping elements
FLE 10.8
FLEX-C10152-00-7600



FLENDER SIP

Standard Industrial Planetary Gear Units

MD 31.1

PDMD-C10154-00

**FLENDER CHG**

Helical Gear Units

MD 20.10

PDMD-C10155-00

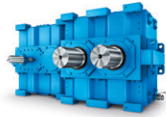
**Gear units**

Fast Track

MD 20.12

PDMD-C10156-00

**Bucket Elevator Drives**

MD 20.2

PDMD-C10157-00

**PLANUREX 3**

Planetary Gear Units

FLE 20.3

FLEX-C10052-00-7600

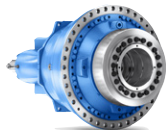
**Paper Machine Drives**

MD 20.5

PDMD-C10159-00

**Conveyor Belt Drives**

MD 20.6

PDMD-C10160-00

**Marine Reduction Gearboxes**

MD 20.7

PDMD-C10161-00

**DUORED 2**

Helical Gear Units, Load-sharing

MD 20.8

PDMD-C10162-00

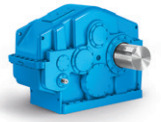
**Pinion Drive for Tube Mills**

MD 20.9

PDMD-C10163-00





THE RIGHT GEAR UNIT SOLUTION FOR ANY REQUIREMENT

We provide helical and planetary gear units made up of standard modules or as a complete application solution.

Helical and planetary gear units from Flender are modern drive solutions that satisfy the most varying and extreme demands, day after day and year after year. For decades, plant operators have been achieving high system reliability and low lifecycle costs in every conceivable industry with our helical gear units.

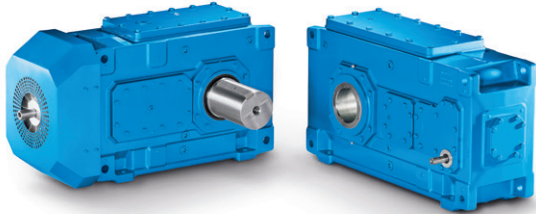

Helical and bevel helical gear units

Flender helical and bevel helical gear units are by far the most comprehensive range of industrial gear units in the world. It ranges from a multi-faceted universal gear unit portfolio and application-specific gear units to customer-specific solutions.

Rated torque: 3,300 Nm ... 1,400,000 Nm

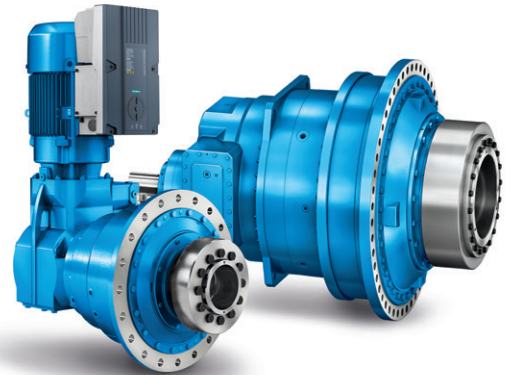

Planetary Gear Units

With Flender planetary gear units, we provide a range of durable, reliable and finely graduated gear unit solutions. The series wins customers over due to its highly integrated planetary geared motor and maximum conformity with all international motor standards. It also brings quality and performance in a good ratio of lifecycle costs to price.

Rated torque: 10,000 Nm ... 5,450,000 Nm

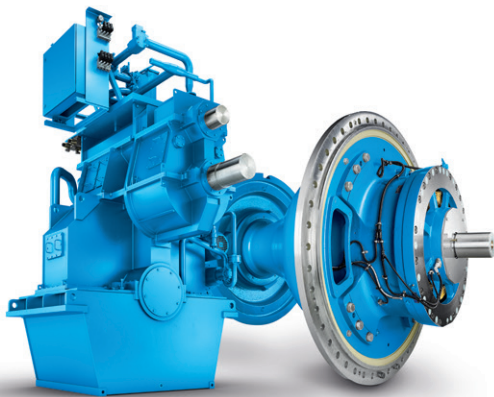

Application-specific gear units

With application-specific gear units, Flender provides by far the most application solutions and thus covers nearly every drive-related need from hundreds of applications in industry and the acquisition of raw materials.

Rated torque: up to 10,000,000 Nm



Customer-specific designs

Our experts are available at any time for special requirements during the development of new products. From designing and simulating complex drive solutions to implementing them, we work together with you to resolve multi-layered tasks.

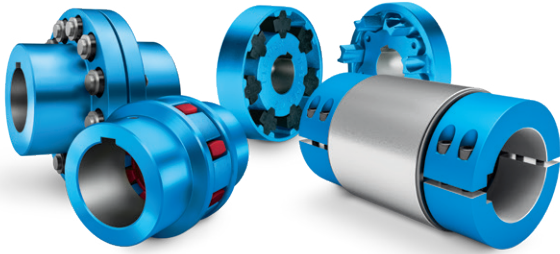

Flexible couplings

Our elastic couplings are pluggable and easy to install. The elastomer element equalizes the shaft offset and absorbs impacts from the motor or driven machine.

Nominal output torque: 12 Nm ... 1,690,000 Nm



Torsionally rigid couplings

Our compact steel couplings provide extremely precise transmission of high torques, especially in harsh operating conditions and extreme temperatures.

Nominal output torque: 92 Nm ... 7,200,000 Nm



Hydrodynamic couplings

Soft start, overload protection, torsional vibration damping – FLUDEX® fluid couplings allow the torque-limited approach and have very little slippage at rated load.

Power: 1.2 kW ... 2,500 kW



Highly-flexible couplings

Highly flexible couplings are well-suited for connecting machines that operate asymmetrically. They are preferred for use in systems that are periodically operated.

Nominal output torque: 24 Nm ... 90,000 Nm

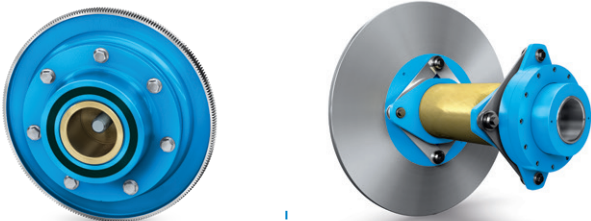

Application-specific couplings

Flender offers a variety of application-specific couplings for rail vehicles and use in wind energy generation.

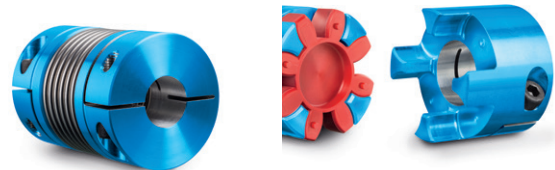

Backlash-free couplings

Our couplings act as a modular interface between the motor and the work machine to ensure reliable, backlash-free power transmission in servodrives and positioning drives.

Nominal output torque: 0.1 Nm ... 5,000 Nm

Flender's system competence turns first-class components into systems with tangible added value. Drive systems from Flender ensure maximum productivity, energy efficiency and reliability in any automation environment.

Consultation

Our customers use our interdisciplinary know-how, our application competence, our innovation strength and, last but not least, our experience to find the right drive system for their individual requirements.

Reduced engineering time, lower costs



Integrated drive portfolio

We not only provide gear units and couplings, but also have the competence in electrical drive technology that enables us to offer the entire drive train – perfectly integrated, with optimal interaction between all components, as a standard or individual solution.

Fewer interface risks, more efficiency

INDIVIDUAL SOLUTIONS.

We have the right solution for you, even if your requirements are special. We no longer have to newly develop every special solution. Many solutions are already available.

At [flender.com](https://www.flender.com), we provide application-specific solutions for your special requirements.

Use our online configurator, which allows you to create tailored product combinations.

Flender service

From diagnostics and support, replacement part and repair services, all the way to maintenance and retrofit services – the Flender service portfolio creates individual solutions, fully and completely tailored to the needs of our customers. In this way, a gear unit remains an original Flender gear unit.

Increased system availability, reduced lifecycle costs

DIAGNOSTEX

Ensuring the process stability requires status-oriented maintenance of the drive train. With DIAGNOSTEX®, sensors measure deviations of our gear units from the target status. These can be analyzed and evaluated in terms of maximized system availability.

Industrie 4.0, reduced costs

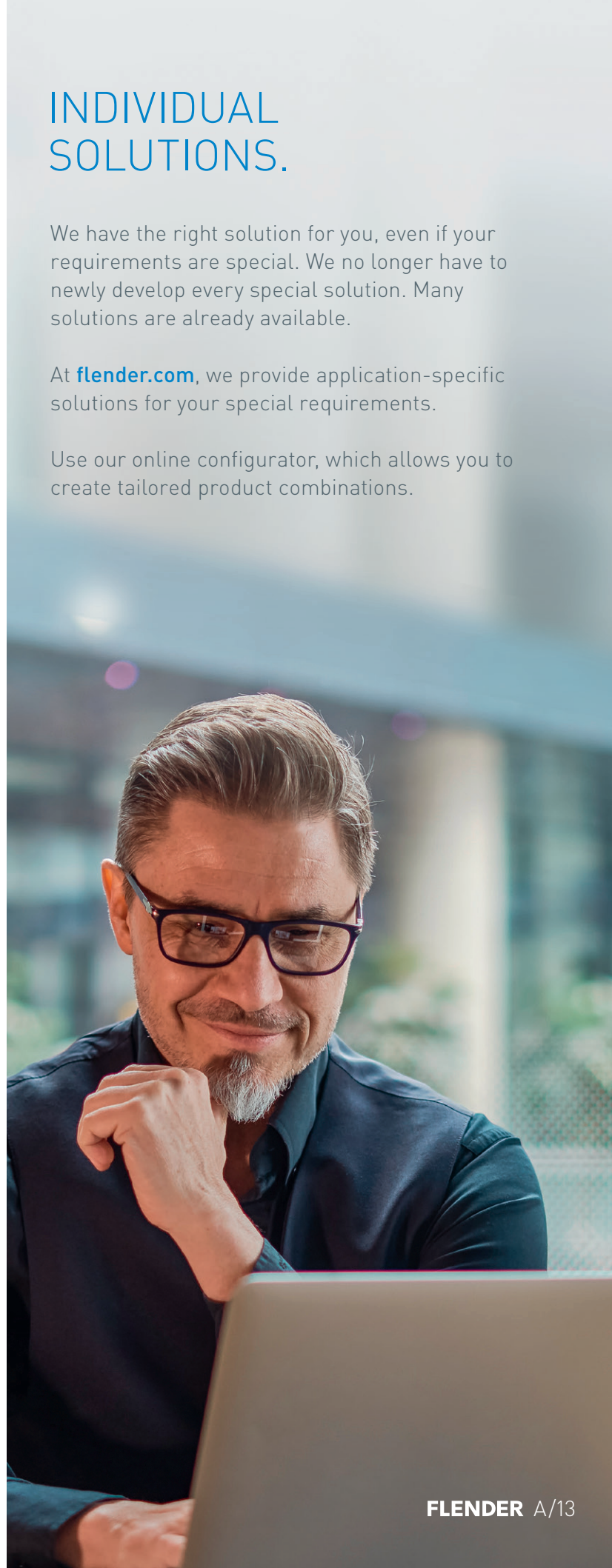

GREAT EXPERTISE IN YOUR INDUSTRY TOO.

Each industry has its own conditions. Every application has its own specific requirements. We are looking forward to meeting your challenges.

We probably already have the right solution at hand. Here are a few examples:



Minerals and mining

Requirement:
Perfectly coordinated drive system



Cement

Requirement:
Low maintenance effort and cost,
sealing due to dirt in surroundings



Plastics and rubber

Requirement:
Absorption of high axial forces,
suitability for explosion protection



Environmental and recycling

Requirement:
Highest possible reliability, rugged
design



Pulp and paper

Requirement:
Suitability for centrally located
lubrication



Industrial cranes

Requirement:
Quick availability, version with
double drive shaft



Chemicals

Requirement:
Absorption of forces from the manufacturing process



Power generation

Requirement:
Effective cooling, speed adjustment for motor to fan

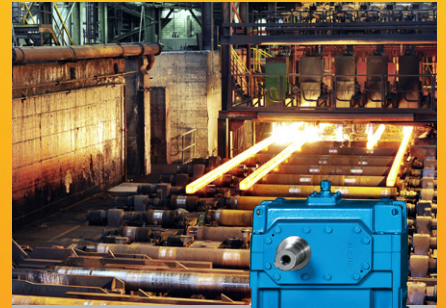

Metals

Requirement:
Harsh working conditions, high peak loads



Harbor cranes

Requirement:
Specific axle clearance, frequent start-up



Oil and gas

Requirement:
Flexible adaptation to speed requirements



Water and wastewater

Requirement:
Absorption of external forces, oil-retaining pipe required



AN ORIGINAL FOR THE LONG TERM WITH ORIGINAL FLENDER SERVICES

Ever increasing requirements make it more and more important for industrial plants to work with maximum productivity and efficiency. Flender Services give companies a decisive advantage over the competition in industry, the acquisition of raw materials and energy production. In view of the high cost pressure, increasing energy prices and stricter and stricter environmental stipulations, our services are becoming a decisive factor to success over the competition.

Enjoy the support of our service experts, from planning, development and operation to the modernization of your plant and benefit from our experience and in-depth know-how of your application – in more than 100 countries, seven days a week, 24 hours a day.

Reduce standstills, minimize downtimes due to failure, and increase the productivity, flexibility and cost efficiency of your plant.

OUR OFFER FOR GEAR UNITS AND COUPLINGS AT A GLANCE.

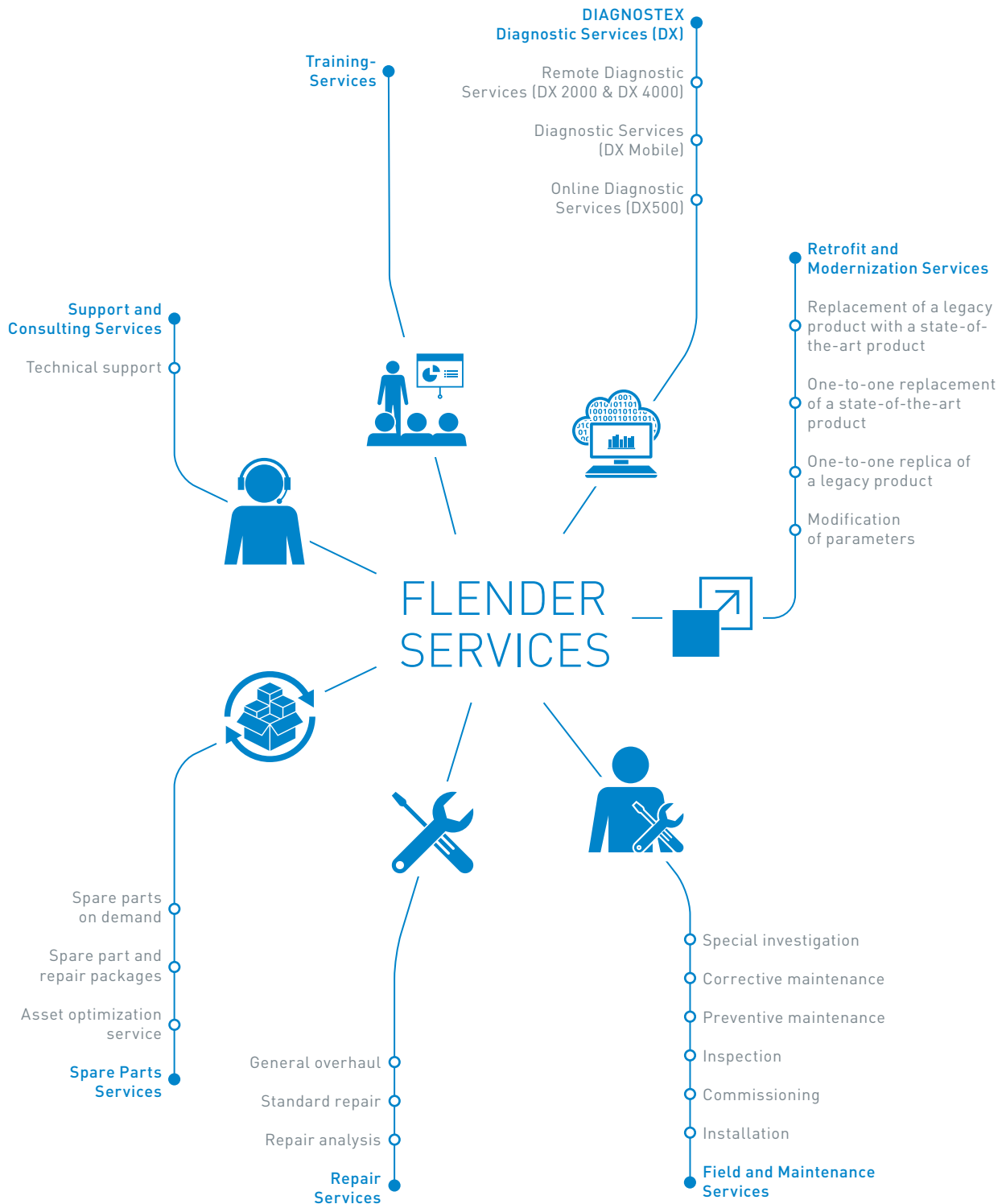

FLENDER COUPLINGS CATALOG **FLE 10.1** EDITION 2023.2 EN



WE
MOVE_{the}
WORLD

Flender GmbH
Alfred-Flender-Straße 77
46395 Bocholt
Germany

Article no.: FLEX-C10001-00-7600

Subject to changes and errors.

The information given in this product catalog includes descriptions and performance features that in specific applications do not always apply in the form described or may change through further-development of the products. The desired performance features are binding only if they are expressly agreed on conclusion of contract. Subject to availability for delivery and to technical changes.