

EtherCAT®

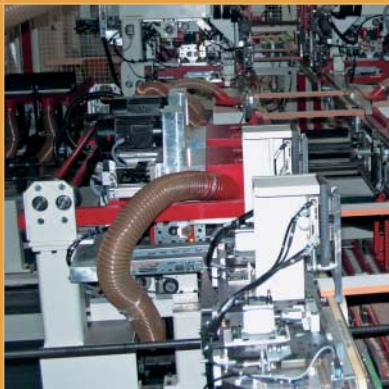

Content

2 EtherCAT Technology Group

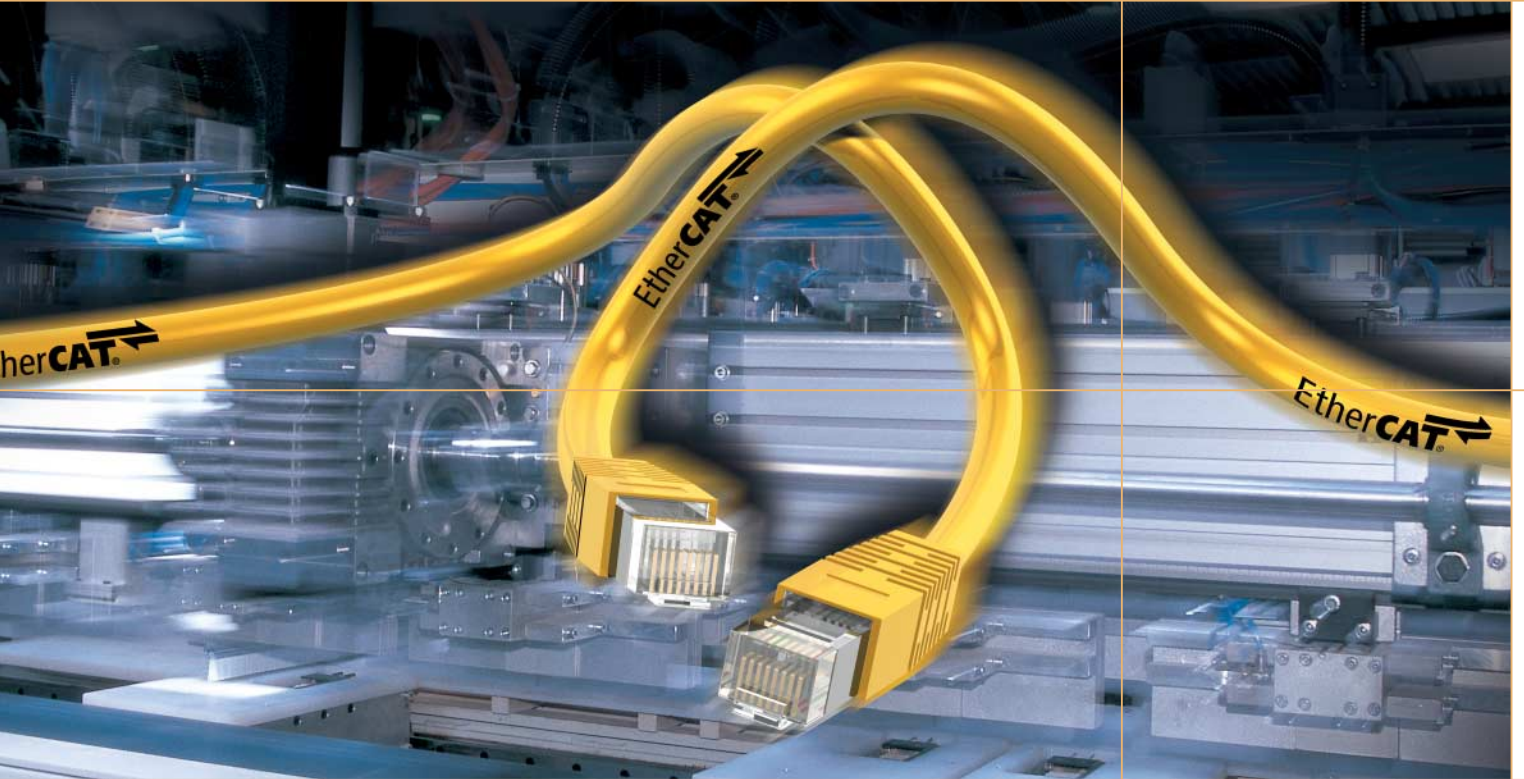
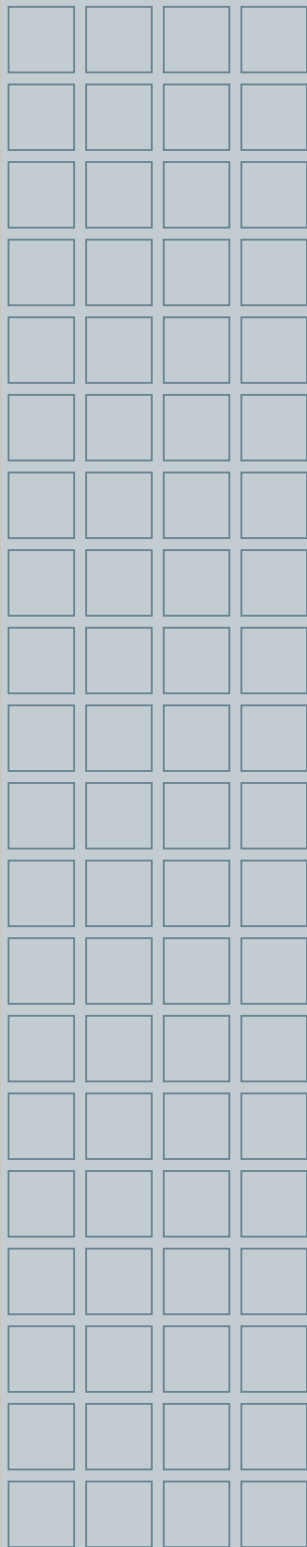

3

Why EtherCAT?



4

User and Vendor Statements



6

ETG Member Companies at a Glance



8

ETG Memberlist



10

EtherCAT Technology Group



12

EtherCAT – Technical Introduction and Overview



20

Implementation Aspects



22

Applications

23

Product Examples



24

Contact



■ Why EtherCAT?

EtherCAT Technology Group 3

- **its Industrial Ethernet**
 - | Standard Ethernet frames used
 - | Supports all Internet Technologies
 - | HTTP, FTP, TCP/IP – without degrading the real time behavior
 - | Simplifies vertical integration
- **its faster**
 - | The fastest system available, with outstanding synchronization features
 - | Performance widely independent of topology
 - | No underlying sub-system required any more
 - | Meets today's and tomorrows requirements
- **its easy to use**
 - | No manual address setting
 - | No switch configuration
 - | Auto configuration features
 - | Diagnosis with exact localization
- **its flexible topology**
 - | All topologies supported: Line, Tree, Star, Ring
 - | No node, switch or hub cascading issues
 - | Up to 65535 nodes per segment
 - | Redundancy, Hot Connect, Hot Swap options
- **its Safety on Ethernet**
 - | Safety application and standard automation with one network
 - | Protocol developed to international safety standard IEC 61508
 - | Suitable for safety I/O and safety drives
 - | Routable via gateways and fieldbus systems
- **its open**
 - | Open Technology, fully disclosed
 - | Supported by the worlds largest Industrial Ethernet Organization
 - | EtherCAT is IEC Specification: IEC/PAS 62407
 - | Supports well established device profiles
- **its future proof**
 - | Widely supported
 - | Controller chips from multiple sources
 - | International standardization
 - | No use of outdated technology
- **its versatile**
 - | Master-Slave, Slave-Slave and Master-Master Communication
 - | Cyclic and acyclic services for process data and parameter data
 - | Suitable for centralized and distributed control architectures
 - | Machine control, robotics, embedded systems, building automation, transport systems, ...
- **its cost effective**
 - | Meets or even undercuts fieldbus cost levels
 - | No special master cards required – on-board MAC or low cost standard NIC is fine
 - | Highly integrated Slave Controllers for lower interface costs
 - | No active Infrastructure components required
- **its well proven**
 - | Deployed in series applications since 2003
 - | Thousands of nodes shipped
 - | Implemented on variety of controllers and operating systems
 - | Large product selection

■ User and Vendor Statements

4 EtherCAT Technology Group



■ Dieter Hess, Managing Director, 3S Smart Software Solutions GmbH

“3S decided to implement EtherCAT as the first real-time Ethernet protocol, since EtherCAT utilises the maximum performance of Ethernet. For us as a software manufacturer, the fact that the master implementation is independent of special plug-in cards is particularly attractive. The software can be based on the universally available standard Ethernet controller. The openness of the system and Beckhoff’s active support for ETG are further significant factors.”



■ Clement Peters, Coordinator for Control and Drive Systems, Schuler AG, and ETG Board Member:

“EtherCAT enables us to realize fast drive and hydraulic controls for all applications currently used in the Schuler Group. Another crucial factor is that, due to EtherCAT’s performance, we still have enough potential for solving complex control tasks in future without speed problems. Apart from the functional features of a technology, availability of a wide range of components is very significant for users of automation devices. The fact that so shortly after ETG was established so many member companies are already presenting EtherCAT products and that further products are in preparation is clear evidence for the success of this young technology. The main factor determining user acceptance continues to be simple and effective handling of the EtherCAT system in terms of configuration and diagnosis.”

potential for solving complex control tasks in future without speed problems. Apart from the functional features of a technology, availability of a wide range of components is very significant for users of automation devices. The fact that so shortly after ETG was established so many member companies are already presenting EtherCAT products and that further products are in preparation is clear evidence for the success of this young technology. The main factor determining user acceptance continues to be simple and effective handling of the EtherCAT system in terms of configuration and diagnosis.”



■ Kim Hartman, VP Sales & Marketing, TenAsys Corporation

“The EtherCAT standard has potential to be a significant and disruptive technology in lowering costs and improving performance of hard real time

Ethernet based fieldbus applications. As a 25 year supplier of the hard real time operating systems of iRMX and INtime for Windows, TenAsys is particularly aware of the highly optimized structure used in EtherCAT telegrams. The EtherCAT Technology Group continues to add value through cooperative efforts in building a significant and substantial foundation of partners and customers. We’re very pleased to be associated with the ETG and Beckhoff, and in putting forth effort towards supplying a robust, and high performance real time EtherCAT master for OEM application.”



■ Dr. Peter Heidrich, R&D Manager, Baumüller GmbH, and ETG Board Member:

“Baumüller decided to use EtherCAT due to the significant benefits it can offer, particularly in terms of price/performance ratio and availability. This decision was underlined through our active collaboration in the ETG executive committee. We continue to be convinced that the decision for EtherCAT was the right one. As soon as EtherCAT slave controllers became available, Baumüller started producing connections for the b maXX 4400 system in August 2004. ETG has demonstrated that, due to the universality of the EtherCAT technology, EtherCAT-based systems can be developed and realised very quickly.”

convinced that the decision for EtherCAT was the right one. As soon as EtherCAT slave controllers became available, Baumüller started producing connections for the b maXX 4400 system in August 2004. ETG has demonstrated that, due to the universality of the EtherCAT technology, EtherCAT-based systems can be developed and realised very quickly.”

■ Günter Redeker, Manager Electrical Design, IMA

“IMA is known for high-tech machines for the furniture industry. We have been using PC based controls for years, since this technology provides outstanding performance for dynamic and precise motion applications. EtherCAT is the matching communication system. We found that using EtherCAT instead of a legacy fieldbus significantly reduces the CPU load of the control system, even though intelligent master cards are not required any more. So we gain performance at reduced costs.”



■ **Hans Beckhoff, Managing Director, Beckhoff GmbH**

“Naturally, EtherCAT is particularly suitable for fast PC-based controls. The master requires no plug-in card and can be implemented on any existing Ethernet controller using a very simple interface. EtherCAT is therefore also well suited to small and medium control technology, where it opens up new areas of application for distributed control. Therefore EtherCAT is the communication backbone of Beckhoff system architecture and we are very pleased about the worldwide success of this technology.”



■ **Martin Rostan, Product Manager, Beckhoff and Executive Director, EtherCAT Technology Group:**

“We are pleased that the EtherCAT Technology Group is now the largest Industrial Ethernet organisation in the world. The strong growth of the ETG reflects the tremendous interest in EtherCAT technology. Manufacturers and users recognise the benefits offered by EtherCAT: future-proof performance, flexible network topology, simple configuration, and low costs. Nevertheless, while the number of members is an important criterion for the success of a technology organisation, it is not the crucial one. Acceptance of the technology resulting in product developments and applications is even more important. Here too, EtherCAT has been very successful.”



■ **Ludger Borgmann, System Designer, Philips Medical Systems**

“We believe that EtherCAT is the right technology for the next step towards a system control architecture that enables us to further reduce costs and allows for new innovations, which the current architecture is not suitable to serve for. The performance of EtherCAT will allow us to implement hard-realtime, safety, and control-functions on one single cable, while simultaneously offering flexible topologies, which will reduce cable-costs significantly.

Not only performance, but also international standardization and worldwide acceptance are important features of EtherCAT. Our changeover to EtherCAT is simplified through the use of CANopen device profiles and the availability of gateways and converters, since we are not able to convert all of our subsystems and components in one big step.”



■ **Chris Choi, Director, Controls Engineering, Husky Injection Molding Systems Ltd.**

“Keeping our customers in the lead is never easy! One of the means to sustain this capability is a continuous renewal of our controls technology. In our pursuit of the next generation of controls, EtherCAT stands out as a fieldbus technology with the best value. No PCI interface card means lower fieldbus cost, lower PC cost and ultimately lower system cost. The unique address mapping technique of EtherCAT brings the real-time industrial Ethernet to reach its highest potential. We are yet to be convinced otherwise by other contenders that they are both technically and economically superior to EtherCAT.”

“We have evaluated EtherCAT and find especially exciting that this communication technology allows to connect fieldbus scanner cards, digital motion amplifiers as well as fast I/O using just one Ethernet port instead of multiple PCI slots. Introducing EtherCAT hence does not require to abandon all well established fieldbus systems right away but provides a smooth migration path especially in demanding motion control applications.”



■ **Holger Zeltwanger, Managing Director, CAN in Automation e.V.:**

“CANopen and EtherCAT are two communication systems that complement one another in an optimal way. By using harmonised application layers a simplified integration through gateways is supported. This is even facilitated by EtherCAT using many of the CANopen device profiles.”

■ **Dmitry Dzilno, Manager, Controls Group, Applied Materials Inc.**

“We have evaluated EtherCAT and find especially exciting that this communication technology allows to connect fieldbus scanner cards, digital motion amplifiers as well as fast I/O using just one Ethernet port instead of multiple PCI slots. Introducing EtherCAT hence does not require to abandon all well established fieldbus systems right away but provides a smooth migration path especially in demanding motion control applications.”

■ The EtherCAT Technology Group members at a glance [as of November 2005]

The EtherCAT Technology Group has become the largest Industrial Ethernet organization in the world. Founded in November 2003, it is also the fastest growing fieldbus organization. As of November 2005, there are 235 members from 25 countries: from Australia, Austria, Belgium, Canada,

China, Denmark, Germany, Finland, France, Great Britain, India, Israel, Italy, Japan, Korea, Liechtenstein, the Netherlands, Singapore, Spain, Sweden, Switzerland, Taiwan, Turkey, Ukraine and the USA.

6 EtherCAT Technology Group





■ The EtherCAT Technology Group memberlist [as of November 2005]



3S-Smart Software Solutions GmbH, Germany	Caesar Datensysteme GmbH, Germany	GAS – Gesellschaft für Antriebs- u. Steuerungstechnik mbH, Germany
3S-Systems GmbH, Germany	CEGELEC, Belgium	Hahn-Meitner-Institut Berlin GmbH, Germany
ABB Power Technologies AB, Sweden	Chr. Mayr GmbH & Co.KG, Germany	Hans Turck GmbH & Co.KG, Germany
ABB Stotz-Kontakt GmbH, Germany	Cimetrics Inc., USA	Harting Electric GmbH & Co.KG, Germany
ABM automation building messaging gmbh, Austria	Cleveland Motion Controls, USA	Heesemann GmbH & Co.KG, Germany
acontis technologies GmbH, Germany	Continental AG, Germany	HEINZ SIEGFRIED AG, Switzerland
ACS-Tech80 Ltd., Israel	Control Techniques, UK	Hengstler GmbH, Germany
Advantech Co. Ltd., Taiwan	Danaher Motion GmbH, Germany	Hilscher GmbH, Germany
AeroLas GmbH, Germany	Danaher Motion Stockholm AB, Sweden	HMS Industrial Networks AB, Sweden
ALSTOM Power Conversion, Germany	Delta Tau Data Systems Inc., USA	Hochschule Aalen, Germany
Altera GmbH, Germany	Deutschmann Automation GmbH & Co.KG, Germany	Hübner Elektromaschinen GmbH, Germany
AMK GmbH & Co.KG, Germany	DeWind GmbH, Germany	Husky Injection Molding Systems Ltd., Canada
Anca PTY Ltd., Australia	Dieffenbacher GmbH & Co.KG, Germany	iba AG, Germany
Andrive Antriebstechnik GmbH, Germany	Digitronic Automationsanlagen GmbH, Germany	IBS Prüfsysteme, Germany
Applied Materials Inc., USA	Deutsches Zentrum für Luft- u.Raumfahrt e.V., Germany	ICP DAS Co. Ltd., Taiwan
Aradex AG, Germany	Dynaservo Inc., Canada	IDAM – INA – Drives & Mechatronics GmbH & Co.KG, Germany
Arlington Laboratory Corp., USA	Eagle Precision Technologies Inc., Canada	IMA Automation GmbH, Germany
as electronics GmbH, Germany	EasyMatics Ltd., UK	Imperial Tobacco Limited, Germany
ASIRobicon S.p.A., Italy	Electroglas Inc., USA	IMS Messsysteme GmbH, Germany
ASM Technology Singapore Pte.Ltd., Singapore	Electronic Control Systems, Italy	Indumat GmbH & Co.KG, Germany
Automata GmbH & Co.KG, Germany	Eleks Software Ltd., Ukraine	Industrial Dynamics Company, USA
AutomationX GmbH, Austria	Elmar Vögel Software & Automation, Austria	Industrielle Automatisierung Kremer BV, Netherlands
Aweta G&P, Netherlands	elrest Automationssysteme GmbH, Germany	Infranor Electronics SAS, France
AXIOM GB Ltd., Great Britain	Eltromat GmbH, Germany	Ingenieurgemeinschaft IgH, Germany
Baldor UK Ltd., Great Britain	Epis Microcomputer GmbH, Germany	ITT Flygt AB, Sweden
Balluff GmbH, Germany	ESR Pollmeier GmbH, Germany	IVECO Motorenforschung AG, Switzerland
BAS efficiency, Netherlands	ETAS GmbH, Germany	IVO GmbH & Co.KG, Germany
Baumüller Nürnberg GmbH, Germany	Fachhochschule München, Germany	Janz Automationssysteme AG, Germany
BE Semiconductor Industries N.V., Netherlands	Fachhochschule Solothurn, Switzerland	Jetter AG, Germany
Beck IPC GmbH, Germany	Fagor Automation s.coop., Spain	Justek Inc., Korea
Beckhoff Automation GmbH, Germany	FERAG AG, Switzerland	K.Mecs Co. Ltd., Japan
Berghof Automationstechnik GmbH, Germany	ferrocontrol Steuerungssysteme GmbH & Co.KG, Germany	Kayser Threde GmbH, Germany
Berner Fachhochschule für Technik und Informatik, Switzerland	FH Gießen – Friedberg, Germany	KEB Antriebstechnik, Germany
Bhend Automation AG, Switzerland	FH Ingolstadt, Germany	KEBA AG, Austria
Billhöfer Maschinenfabrik GmbH & Co.KG, Germany	Finn-Power Oy, Finland	KineticaRT Ltd., UK
Binar AB, Sweden	Fisher Technical Services Inc., USA	Kithara Software GmbH, Germany
b-plus GmbH, Germany	Flanders' MECHATRONICS Technology Centre, Belgium	KK-electronic a/s, Denmark
Brosis Engineering GmbH, Germany	Focke & Co., Germany	Komax AG, Switzerland
Bruderer Maschinenfabrik AG, Switzerland	Fraba Posital GmbH, Germany	König Prozessautomatisierung GmbH, Germany
Bruker Daltonik GmbH, Germany	Fritz Kübler GmbH, Germany	Kuhnke GmbH, Germany
	Fronius International GmbH, Austria	Kuka Controls GmbH, Germany
	Fuji Electric FA Components & Systems Co., Ltd., Japan	KW-Software GmbH, Germany
		Leister Process Technologies, Switzerland
		Lemoine, France

■ EtherCAT Technology Group



10 EtherCAT Technology Group



Everyone should be able to use and implement EtherCAT. The EtherCAT Technology Group stands for this philosophy. The ETG is a forum for end users from different sectors, and for machine manufacturers and suppliers of powerful control technology with the aim of supporting and promoting EtherCAT technology. The wide range of industry sectors that are represented ensures that EtherCAT is optimally prepared for a large number of applications. With their qualified feedback, the system partners ensure simple integration of the hardware and software components in all required device classes.

The ETG Technical Committee meets frequently to review the technology. Technical Task Forces look after topics like device profile integration, safety, wiring, standardization or test and certification.

In Training Classes and Seminars the ETG provides detailed information about the Technology.

In August 2004, the Management Board of the International Electrotechnical Commission (IEC) approved the Liaison of the EtherCAT Technology Group with the IEC Committee for Digital Communication: The ETG now is official standardization partner organization.

Benefits of membership

- Member companies receive preferred access to specification drafts, specifications, white papers, tools, prototype evaluation products and initial batch products and thus have a head start in evaluating, using or implementing the EtherCAT technology.
- The members are eligible to participate in working groups and gain influence on future enhancements of the EtherCAT technology specifications.
- ETG represent the member's interest in international standardization committees such as IEC and ISO.



EtherCAT Technology Group 11



- ETG members have access to the members-only part of the EtherCAT web-site, which provides specifications still in development, a developers forum and up-to date information regarding the technology.
- The ETG office answers technical inquiries regarding EtherCAT, provides marketing assistance, publishes product guides, issues press releases and articles, promotes EtherCAT via its website and organizes joint fair and exhibition booths.

networks in real-time applications), which is being developed with involvement by ETG experts. EtherCAT technology will also be integrated in the next version of the international fieldbus standard, IEC 61158, and in IEC 61800-7 (Profiles and Interfaces for adjustable speed electrical power drive systems). The International Standardisation Organisation (ISO) includes EtherCAT in the ISO15745 standard.



International Standardization

With 96% of the votes from IEC member states, EtherCAT became an official IEC specification in February 2005: IEC/PAS 62407. Beyond this highly significant standardization step, EtherCAT also makes its way into other international standards. For example, EtherCAT is currently being introduced in the IEC 61784-2 standard (Digital data communications for measurement and control – Part 2: Additional profiles for ISO/IEC 8802-3 based communication

■ Technical Introduction and Overview

This section provides an in-depth introduction into EtherCAT, the Ethernet-based fieldbus system. EtherCAT sets new performance standards. Handling is straightforward and similar to a fieldbus, thanks to flexible topology and simple configuration. Moreover, since EtherCAT can be implemented very cost-effectively, the system enables fieldbuses to be used in applications where fieldbus networking was not an option in the past.

■ Introduction

Fieldbuses have become an integrated component of automation technology. They have been tried and tested and are now widely established. It was fieldbus technology that enabled the wide-scale application of PC-based control systems. While the performance of controller CPUs – particularly for IPCs – is increasing rapidly, conventional fieldbus systems tend to represent “bottlenecks” that limit the performance control systems can achieve. An additional factor is the layered control architecture consisting of several subordinate (usually cyclic) systems: the actual control task, the fieldbus system and perhaps local expansion busses within the I/O system or simply the local firmware cycle in the peripheral device. Reaction times are typically 3-5 times higher than the controller cycle time – an unsatisfactory solution (see Fig. 1).

Above the fieldbus system level, i.e. for networking controllers, Ethernet has already been the state of the art

for some time. What is relatively new is its application at the drive or I/O level, i.e. in areas that were dominated by fieldbus systems in the past. The main requirements for this type of application are high real-time capability, suitability for small data quantities, and naturally cost-effectiveness. EtherCAT meets these requirements and at the same time makes internet technologies available at the I/O level.

■ Ethernet and real-time capability

There are many different approaches that try and provide real-time capability for Ethernet: for example, the CSMA/CD media access procedure is disabled via higher level protocol layers and replaced by the time slice procedure or polling; other propositions use special switches that distribute Ethernet packets in a precisely controlled timely manner. Whilst these solutions may be able to transport data packets more or less quickly and accurately to the

■ Figure 1: Response times of conventional fieldbus systems

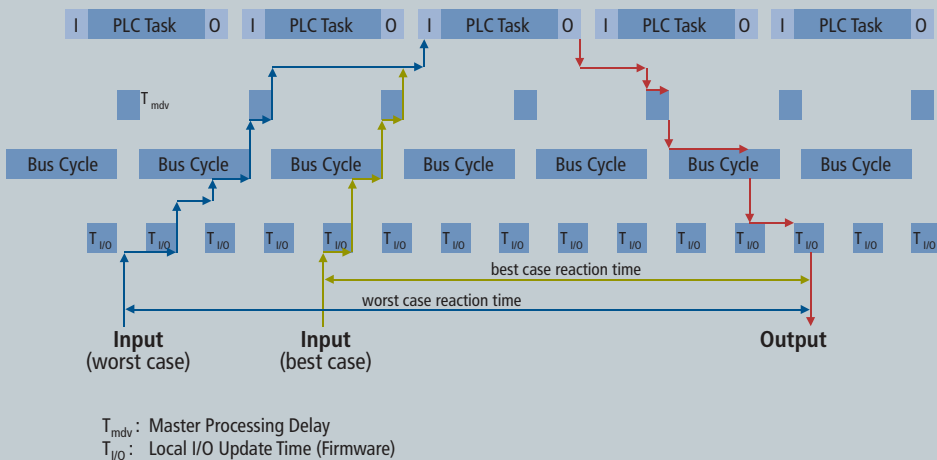

connected Ethernet nodes, the times required for the redirection to the outputs or drive controllers and for reading the input data strongly depend on the implementation.

If individual Ethernet frames are used for each device, the usable data rate is very low in principle: The shortest Ethernet frame is 84 bytes long (incl. inter-packet gap IPG). If, for example, a drive cyclically sends 4 bytes of actual value and status information and accordingly receives 4 bytes of command value and control word information, at 100% bus load (i.e. with infinitely short response time of the drive) a usable data rate of only $4/84 = 4.8\%$ is achieved. At an average response time of $10 \mu s$, the rate drops to 1.9%. These limitations apply to all real-time Ethernet approaches that send an Ethernet frame to each device (or expect a frame from each device), irrespective of the protocols used within the Ethernet frame.

EtherCAT operating principle

EtherCAT technology overcomes these inherent limitations of other Ethernet solutions: the Ethernet packet is no longer received, then interpreted and process data then copied at every device. The EtherCAT slave devices read the data addressed to them while the frame passes through the node. Similarly, input data is inserted while the telegram passes through (see Fig. 2). The frames are only delayed by a few nanoseconds.

Since an Ethernet frame comprises the data of many devices both in send and receive direction, the usable data

rate increases to over 90%. The full-duplex features of 100BaseTX are fully utilized, so that effective data rates of $> 100 \text{ Mb/s}$ ($>90\%$ of $2 \times 100 \text{ Mb/s}$) can be achieved (see Fig. 3).

The Ethernet protocol according to IEEE 802.3 remains intact right up to the individual device; no sub-bus is required. In order to meet the requirements of a modular device like an electronic terminal block, the physical layer in the coupling device can be converted from twisted pair or optical fibre to LVDS (alternative Ethernet physical layer, standardized in [4,5]). A modular device can thus be extended very cost-efficiently. Subsequent conversion from the backplane physical layer LVDS to the 100BASE-TX physical layer is possible at any time – as usual with Ethernet.

Protocol

The EtherCAT protocol is optimized for process data and is transported directly within the Ethernet frame thanks to a special EtherType. It may consist of several EtherCAT telegrams, each serving a particular memory area of the logical process images that can be up to 4 gigabytes in size. The data sequence is independent of the physical order of the Ethernet terminals in the network; addressing can be in any order. Broadcast, Multicast and communication between slaves are possible. Direct Ethernet frame transfer is used in cases where maximum performance is required and the EtherCAT components are operated in the same subnet as the controller.

Figure 2: Process data is inserted in telegrams

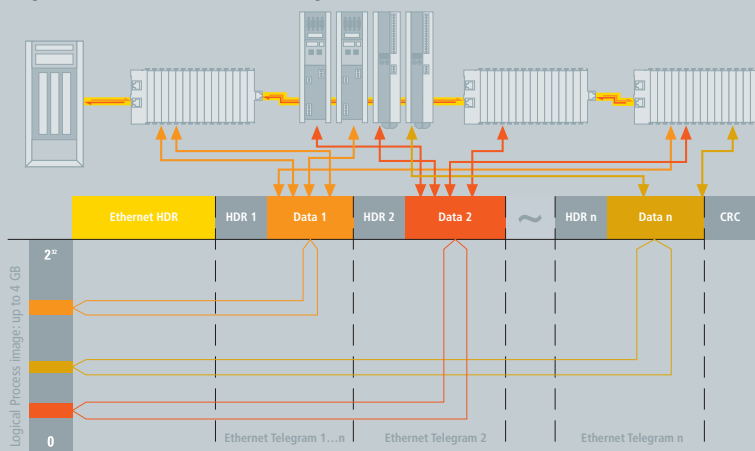
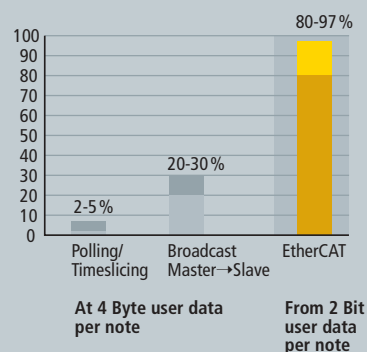

Figure 3: Comparison of Bandwidth Utilisation



However, EtherCAT applications are not limited to single a subnet: EtherCAT UDP packages the EtherCAT protocol into UDP/IP datagrams (see Fig. 4). This enables any control with Ethernet protocol stack to address EtherCAT systems. Even communication across routers into other subnets is possible. In this variant, system performance obviously depends on the real-time characteristics of the control and its Ethernet protocol implementation. The response times of the EtherCAT network itself are hardly restricted at all: the UDP datagram only has to be unpacked in the first station.

In addition to data exchange according to the master/slave principle, EtherCAT is also very suitable for communication between controllers (master/master). Freely addressable network variables for process data and a variety of services for parameterization, diagnosis, programming and remote control cover a wide range of requirements. The data interfaces for master/slave and master/master communication are identical.

For slave to slave communication, two mechanisms are available. Upstream devices can communicate to downstream devices within the same cycle, and thus extremely fast. Since this method is topology dependent, it is particularly suitable for slave to slave communication relationships given by machine design – e.g. in printing or packaging applications. For freely configurable slave to slave communication, the second mechanism applies: the data is relayed by the master. Here two cycles are needed, but

due to the extraordinary performance of EtherCAT this is still faster than any other approach.

EtherCAT only uses standard frames according to [3] – the frames are not shortened. EtherCAT frames can thus be sent from any Ethernet MAC, and standard tools (e.g. monitor) can be used.

■ Topology

Line, tree or star: EtherCAT supports almost any topology (see Fig. 5). The bus or line structure known from the field-busses thus also becomes available for Ethernet, without the quantity limitations implied by cascaded switches or hubs.

Particularly useful for system wiring is the combination of line and branches or stubs: the required interfaces exist on many devices (e.g. on I/O modules); no additional switches are required. Naturally, the classic switch-based Ethernet star topology can also be used.

Wiring flexibility is further maximised through the choice of different cables. Flexible and inexpensive standard Ethernet patch cables transfer the signals in 100BASE-TX mode. Plastic optical fibres (POF) will complement the system for special applications. The complete choice of Ethernet wiring – such as different optical fibres and copper cables – can be used in combination with switches or media converters.

The Fast Ethernet physics (100BASE-TX) enables a cable length of 100 m between two devices. Since up to 65535

■ Figure 4: EtherCAT: Standard Frames according to IEEE 802.3 [3]

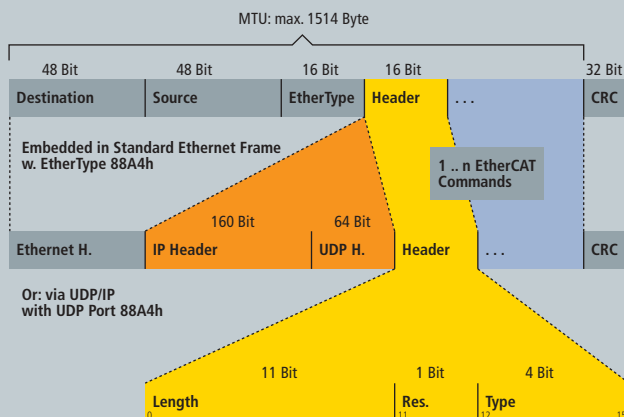

■ Figure 5: Flexible Topology: Line, Tree or Star

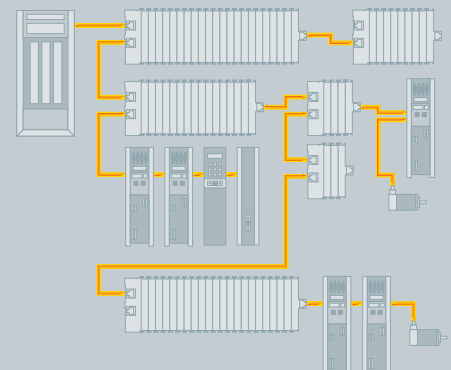

devices can be connected, the size of the network is almost unlimited.

■ Distributed clocks

Accurate synchronization is particularly important in cases where spatially distributed processes require simultaneous actions. This may be the case, for example, in applications where several servo axes carry out coordinated movements simultaneously.

The most powerful approach for synchronization is the accurate alignment of distributed clocks, as described in the IEEE 1588 standard [6]. In contrast to fully synchronous communication, where synchronization quality suffers immediately in the event of a communication fault, distributed aligned clocks have a high degree of tolerance versus possible fault-related delays within the communication system.

With EtherCAT, the data exchange is fully based on a pure hardware machine. Since the communication utilizes a logical (and thanks to full-duplex Fast Ethernet also physical) ring structure, the master clock can determine the propagation delay offset to the individual slave clocks simply and accurately – and vice versa. The distributed clocks are adjusted based on this value, which means that a very precise network-wide timebase with a jitter of significantly less than 1 microsecond is available (see Fig. 6). External synchronization, e.g. across the plant, is then based on IEEE 1588.

However, high-resolution distributed clocks are not only used for synchronization, but can also provide accurate information about the local timing of the data acquisition. For example, motion controllers typically calculate velocities from sequentially measured positions. Particularly with very short sampling times, even a small temporal jitter in the position measurement leads to large step changes in the computed velocity. With EtherCAT, timestamp data types are introduced as a logical extension. The high-resolution system time is linked to the measured value, which is made possible by the large bandwidth offered by Ethernet. The accuracy of a velocity calculation then no longer depends on the jitter of the communication system. It is orders of magnitude better than that of measuring techniques based on jitter-free communication.

■ Performance

EtherCAT reaches new dimensions in network performance. Thanks to hardware integration in the slave and direct memory access to the network controller in the master, the complete protocol processing takes place within hardware and is thus fully independent of the run-time of protocol stacks, CPU performance or software implementation. The update time for 1000 I/Os is only 30 μs – including I/O cycle time (see Table 1). Up to 1486 bytes of process data can be exchanged with a single Ethernet frame – this is equivalent to almost 12000 digital inputs and outputs. The transfer of this data quantity only takes 300 μs .

■ Figure 6: Synchronicity and Simultaneousness: Scope view of two distributed devices with 300 nodes and 120m of cable between them

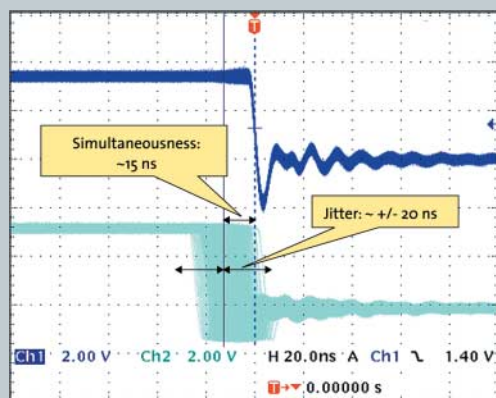

■ Table 1: EtherCAT Performance Overview

Process Data	Update Time
256 distributed digital I/O	11 μs = 0,01 ms
1000 distributed digital I/O	30 μs
200 analog I/O (16 bit)	50 μs \leftrightarrow 20 kHz
100 Servo Axis, with 8 Bytes input and output data each	100 μs
1 Fieldbus Master-Gateway (1486 Bytes Input and 1486 Bytes Output Data)	150 μs

The communication with 100 servo axes is also extremely fast: every 100µs, all axes are provided with command values and control data and report their actual position and status. The distributed clock technique enables the axes to be synchronised with a deviation of significantly less than 1 microsecond. And even at this pace, there is more than sufficient bandwidth for asynchronous communications such as TCP/IP, parameter download or diagnosis data upload.

The extremely high performance of the EtherCAT technology enables control concepts that could not be realised with classic fieldbus systems. With EtherCAT, a communication technology is available that matches the superior computing capacity of modern Industrial PCs. The bus system is no longer the bottleneck of the control concept. Distributed I/Os are recorded faster than is possible with most local I/O interfaces. The EtherCAT technology principle is scalable and not bound to the baud rate of 100 MBaud – extension to GBit Ethernet is possible.

■ Diagnosis

Experience with fieldbus systems shows that availability and commissioning times crucially depend on the diagnostic capability. Only faults that are detected quickly and accurately and located unambiguously can be rectified quickly. Therefore, special attention was paid to exemplary diagnostic features during the development of EtherCAT. During commissioning, the actual configuration of the no-

des (e.g. drives or I/O terminals) should be checked for consistency with the specified configuration. The topology should also match the configuration. Due to the built-in topology recognition down to the individual terminals, this verification can not only take place during system start-up, automatic reading in of the network is also possible (configuration up-load).

Bit faults during the transfer are reliably detected through evaluation of the CRC checksum: The 32 bit CRC polynomial has a minimum hamming distance of 4. Apart from broken wire detection and localisation, the protocol, physical layer and topology of the EtherCAT system enable individual quality monitoring of each individual transmission segment. The automatic evaluation of the associated error counters enables precise localisation of critical network sections. Gradual or changing sources of error such as EMI influences, defective connectors or cable damage are detected and located, even if they do not yet overstrain the self healing capacity of the network.

■ High availability

Increasing demands in terms of system availability are catered for with optional cable redundancy that enables devices to be exchanged without having to shut down the network. Adding redundancy is very inexpensive: the only additional hardware is another standard Ethernet port (no special card or interface) in the master device and the single cable that turns the line topology into the ring.

■ Figure 7: Decentralized Fieldbus Interfaces

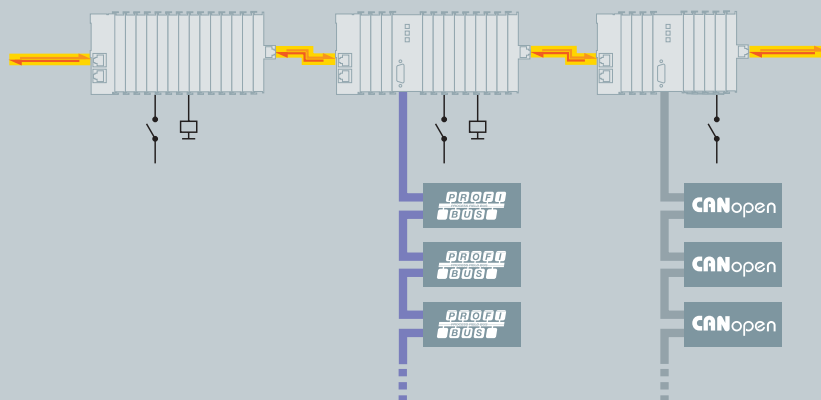

Switchover in case of device or cable failure only takes one cycle, so even demanding motion control applications survive a cable failure without problems. EtherCAT also supports redundant masters with hot standby functionality. Since the EtherCAT slave controllers immediately return the frame automatically if an interruption is encountered, failure of a device does not necessarily lead to the complete network being shut down. Dragchain applications, for example, can thus be specifically configured as stubs in order to be prepared for cable break.

■ Safety

Conventionally, safety functions are realised separately from the automation network, either via hardware or using dedicated safety bus systems. Safety over EtherCAT enables safety-related communication and control communication on the same network. The safety protocol is based on the application layer of EtherCAT, without influencing the lower layers. It is certified according to IEC 61508 and meets the requirements of Safety Integrated Level (SIL) 4. The data length is variable, making the protocol equally suitable for safe I/O data and for safe drive technology. Like other EtherCAT data, the safety data can be routed without requiring safety routers or gateways. First fully certified products featuring Safety over EtherCAT are already available.

■ EtherCAT instead of PCI

With increasing miniaturisation of the PC-components, the physical size of Industrial PCs is increasingly determined by the number of required slots. The bandwidth of Fast Ethernet, together with the process data width of the EtherCAT communication hardware enables new directions: classic interfaces that are conventionally located in the IPC are transferred to intelligent EtherCAT interface terminals (see Fig. 7). Apart from the decentralised I/Os, drives and control units, complex systems such as fieldbus masters, fast serial interfaces, gateways and other communication interfaces can be addressed.

Even further Ethernet devices without restriction on protocol variants can be connected via decentralised switchport devices. The central IPC becomes smaller and therefore more cost-effective. One Ethernet interface is sufficient for the complete communication with the periphery (see Fig. 8).

■ Device profiles

The device profiles describe the application parameters and the functional behaviour of the devices including the device class-specific state machines. For many device classes, fieldbus technology already offers reliable device profiles, for example for I/O devices, drives or valves. Users are familiar with these profiles and the associated parameters and tools. No EtherCAT-specific device profiles have therefore been developed for these device classes. Instead, sim-

■ Figure 8: EtherCAT leads to smaller Controllers



ple interfaces for existing device profiles are being offered. This greatly assists users and device manufacturers alike during the migration from the existing fieldbus to EtherCAT.

■ CANopen over EtherCAT (CoE)

CANopen device and application profiles are available for a wide range of device classes and applications, ranging from I/O components, drives, encoders, proportional valves and hydraulic controllers to application profiles for plastic or textile machinery, for example. EtherCAT can provide the same communication mechanisms as the familiar CANopen [7] mechanisms: object dictionary, PDO (process data objects) and SDO (service data objects) – even the network management is comparable. EtherCAT can thus be implemented with minimum effort on devices equipped with CANopen. Large parts of the CANopen firmware can be reused. Objects can optionally be expanded in order to account for the larger bandwidth offered by EtherCAT.

■ Servodrive-Profil according to IEC 61491 over EtherCAT (SoE)

SERCOS interface™ is acknowledged and appreciated worldwide as a high-performance real-time communication interface, particularly for motion control applications. The SERCOS profile for servo drives and the communication technology are covered by the IEC 61491 standard [8]. This servo drive profile can very easily be mapped to Ether-

CAT. The service channel, and therefore access to all parameters and functions residing in the drive, is based on the EtherCAT mailbox (see Fig. 9). Here too, the focus is on compatibility with the existing protocol (access to value, attribute, name, units etc. of the IDNs) and expandability with regard to data length limitation. The process data, with SERCOS in the form of AT and MDT data, are transferred using EtherCAT slave controller mechanisms. The mapping is similar to the SERCOS mapping. The EtherCAT slave state machine can also be mapped easily to the phases of the SERCOS protocol. EtherCAT provides advanced real-time Ethernet technology for this device profile, which is particularly widespread in CNC applications. The benefits of the device profile are combined with the benefits offered by EtherCAT. Distributed clocks ensure precise network-wide synchronisation. Optionally, the command position, speed or torque can be transferred. Depending on the implementation, it is even possible to continue using the same configuration tools for the drives.

■ Ethernet over EtherCAT (EoE)

The EtherCAT technology is not only fully Ethernet-compatible, but also characterised by particular openness “by design”: the protocol tolerates other Ethernet-based services and protocols on the same physical network – usually even with minimum loss of performance. There is no restriction on the type of Ethernet device that can be connected within the EtherCAT segment via a switch port. The Ethernet

■ Figure 9: Several Device Profiles and Protocols can co-exist side by side

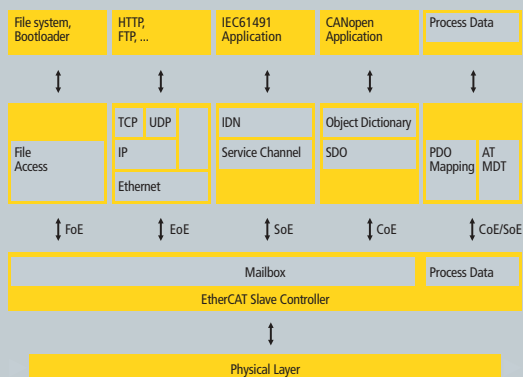

■ Figure 10: Transparent for all Ethernet Protocols

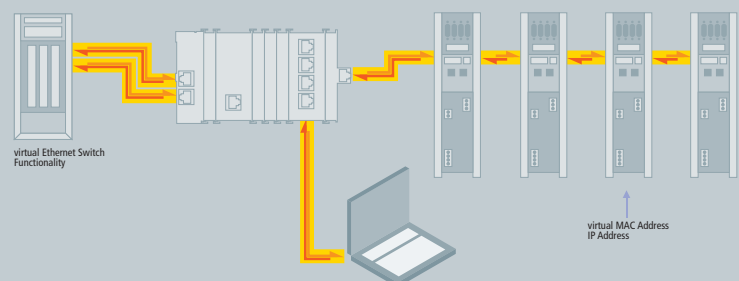

■ Literature

- [1] EtherCAT Technology Group, <http://www.ethercat.org>
- [2] IEC/PAS 62407: Real-Time Ethernet Control Automation Technology (EtherCAT)
- [3] IEEE 802.3: Carrier Sense Multiple Access with Collision Detection (CSMA/CD) Access Method and Physical Layer Specifications.
- [4] IEEE 802.3ae-2002: CSMA/CD Access Method and Physical Layer Specifications: Media Access Control (MAC) Parameters, Physical Layers, and Management Parameters for 10 Gb/s Operation.
- [5] ANSI/TIA/EIA-644-A, Electrical Characteristics of Low Voltage Differential Signaling (LVDS) Interface Circuits
- [6] IEEE 1588-2002: IEEE Standard for a Precision Clock Synchronization Protocol for Networked Measurement and Control Systems
- [7] EN 50325-4: Industrial communications subsystem based on ISO 11898 (CAN) for controller-device interfaces. Part 4: CANopen.
- [8] IEC 61491: Electrical equipment of industrial machines – Serial data link for real-time communication between controls and drives

frames are tunneled via the EtherCAT protocol, which is the standard approach for internet applications (e.g. VPN, PPPoE (DSL) etc.). The EtherCAT network is fully transparent for the Ethernet device, and the real-time characteristics are not impaired (see Fig. 10).

EtherCAT devices can additionally feature other Ethernet protocols and thus act like a standard Ethernet device. The master acts like a layer 2 switch that redirects the frames to the respective devices according to the address information. All internet technologies can therefore also be used in the EtherCAT environment: integrated web server, e-mail, FTP transfer etc.

■ File Access over EtherCAT (FoE)

This very simple protocol similar to TFTP enables access to any data structure in the device. Standardized firmware upload to devices is therefore possible, irrespective of whether or not they support TCP/IP.

■ Infrastructure costs

Since no hubs and switches are required for EtherCAT, costs associated with these devices including power supply, installation etc. are avoided. Standard Ethernet cables and standard low cost connectors are used, if the environmental conditions permit this. For environment requiring increased protection sealed connectors according to IEC standards are specified.

■ Summary

EtherCAT is characterised by outstanding performance, very simple wiring and openness for other protocols. EtherCAT sets new standards where conventional fieldbus systems reach their limits: 1000 I/Os in 30 μ s, optionally twisted pair cable or optical fibre and, thanks to Ethernet and Internet technologies, optimum vertical integration. With EtherCAT, the costly Ethernet star topology can be replaced with a simple line structure – no expensive infrastructure components are required. Optionally, EtherCAT may also be wired in the classic way using switches, in order to integrate other Ethernet devices. Where other real-time-Ethernet approaches require special connections in the controller, for EtherCAT the on-board MAC or very inexpensive standard Ethernet cards (NIC) are sufficient.

EtherCAT is versatile: Master to Slave, Slave to Slave and Master to Master Communication is supported (see Fig. 11). Safety over EtherCAT is available. EtherCAT makes Ethernet down to the I/O level technically feasible and economically sensible. Full Ethernet compatibility, internet technologies even in very simple devices, maximum utilisation of the large bandwidth offered by Ethernet, outstanding real-time characteristics at low costs are outstanding features of this network.

■ Figure 11: Versatile network architecture

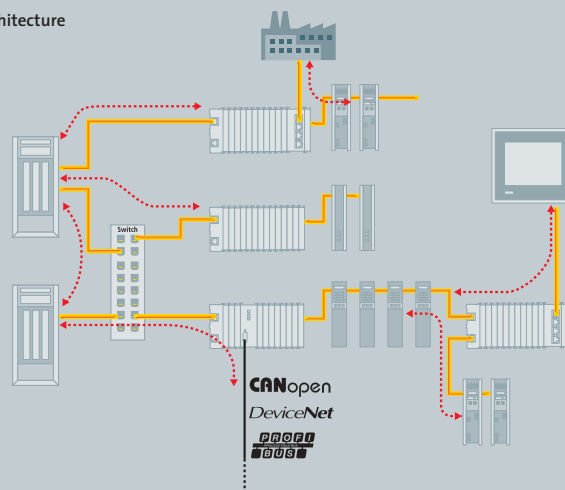

Implementation Aspects

The EtherCAT Technology was developed with very low cost devices in mind, like I/O terminals, sensors, and embedded controllers. EtherCAT only uses standard Ethernet frames according to IEEE 802.3. These frames are sent by the master device, the slave devices extract and/or insert data on the fly. Thus EtherCAT uses standard Ethernet MACs, where they really make sense: in the master device. And EtherCAT slave controllers are used, where such dedicated chips really make sense: in the slave device, where they handle the process data protocol in hardware and provide maximum real time performance regardless of the local processing power or software quality.

Master

EtherCAT communicates a maximum of 1486 Bytes of distributed process data with just one Ethernet frame. So unlike other solutions, where the master device in each network cycle has to process, send and receive frames for each node, EtherCAT systems typically only need one or two frames per cycle for the entire communication with all nodes. Therefore EtherCAT masters do not require a dedicated communication processor. The master functionality puts hardly any load on the host CPU which can handle this task easily besides processing the application program: so EtherCAT can be implemented without special and expen-

sive active plug-in card by just using a passive NIC card or the on-board Ethernet MAC. Implementation of an EtherCAT master is very easy, particularly for small and medium-sized control systems and for clearly defined applications.

For example a PLC with a single process image: if it does not exceed the 1486 bytes, cyclic sending of a single Ethernet frame with the cycle time of the PLC is sufficient. Since the header does not change at run time, all which is required is a constant header to be added to the process image and the result to be transferred to the Ethernet controller.

The process image is already sorted, since with EtherCAT mapping does not occur in the master, but in the slaves – the peripheral devices insert their data at the respective points in the passing frame. This further unburdens the host CPU. It was found that an EtherCAT master entirely implemented in software on the host CPU uses less of its processing power than much slower fieldbus systems implemented with active plug-in cards – even servicing the DPRAM of the active card puts more load on the host.

System configuration tools – available from several manufacturers – provide the network and device parameters including the corresponding boot-up sequence in a standardized XML format.

■ Master-Implementation with one Process Image

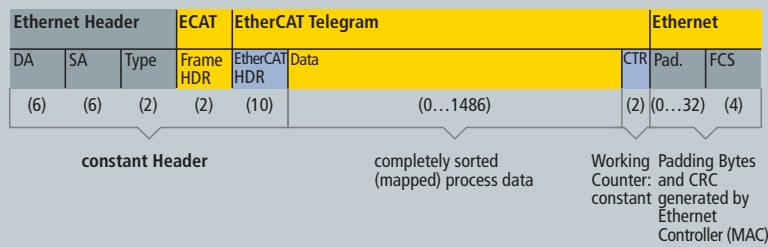

■ Structure of Master Sample Code

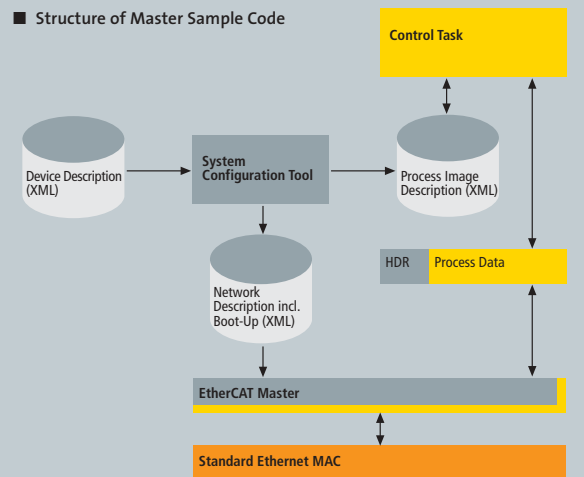

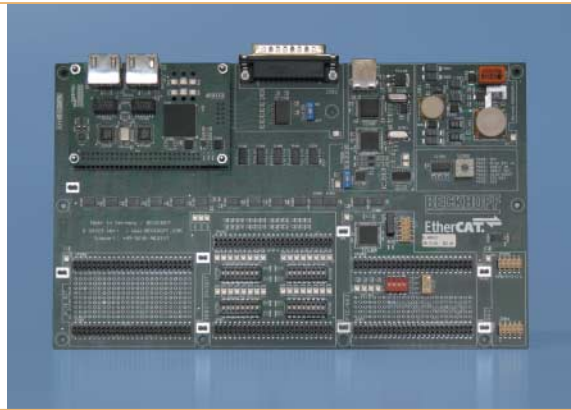

■ **Master implementation services**

Master Code, implementation services and support is available from a variety of vendors and for a variety of hardware platforms and operating systems. Information about this fast growing offering can be found on the EtherCAT website [1]. There even is an open source implementation that comes with an open source RTOS.

■ **Master sample code**

Another possibility to implement an EtherCAT master is to use sample code which is available for a nominal fee. The software is supplied as source code and comprises all EtherCAT master functions, including Ethernet over EtherCAT. All the developer has to do is adapt the code, which was created for Windows environments, to the target hardware and the RTOS used. This has already been done successfully for a number of systems.

■ **Slave**

Several Manufacturers provide EtherCAT slave controllers. Slave controller functionality can also be implemented very cost effectively on FPGAs, for which binary code is available as buy-out license.

The slave controllers typically feature an internal DPRAM and offer a range of interfaces for accessing this application memory:

■ The serial SPI (serial peripheral interface) is intended particularly for devices with small process data quantity, such as analog I/O modules, sensors, encoders or simple drives. This interface is typically used with 8Bit μ Controllers, such as Microchip PIC, DSPic, Intel 80C51 etc.

■ The parallel 8/16-bit microcontroller interface corresponds to conventional interfaces for fieldbus controllers with DPRAM interface. It is particularly suitable for more complex devices with larger data volume. μ Controllers typically using this interface are e.g. Infineon 80C16x, Intel 80x86, Hitachi SH1, ST10, ARM or TI TMS320 Series

■ The 32-bit parallel I/O interface is suitable for the connection of up to 32 digital inputs/outputs, but also for simple sensors or actuators operating with 32 data bits. Such devices do not need a host CPU at all.

■ **Slave Evaluation Kit**

The corresponding Slave Evaluation Kit makes all these interfaces easily accessible. Since with EtherCAT powerful communication processors are unnecessary, the Slave Evaluation Kit contains an 8 bit μ C which optionally can be used as host CPU. The kit comes with slave host software – the equivalent to a protocol stack – in source code, and a reference master software package.

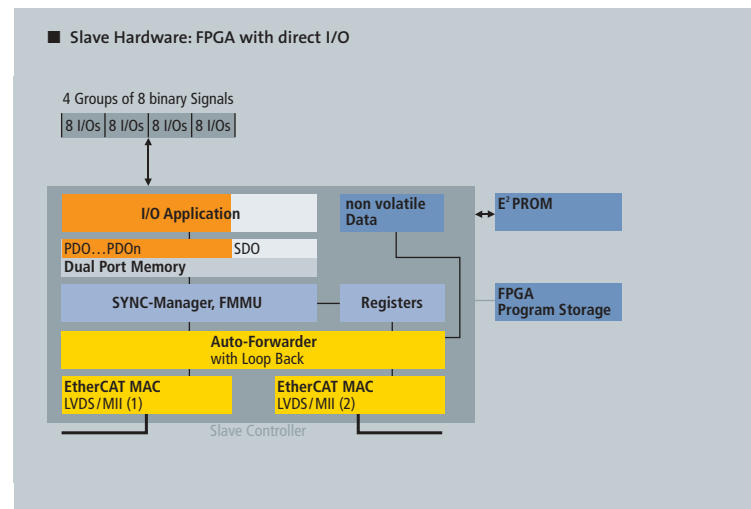
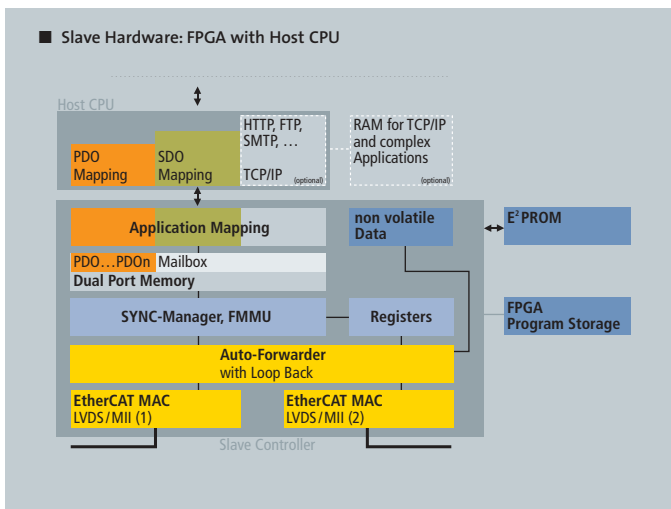

Application Examples

22 EtherCAT Technology Group

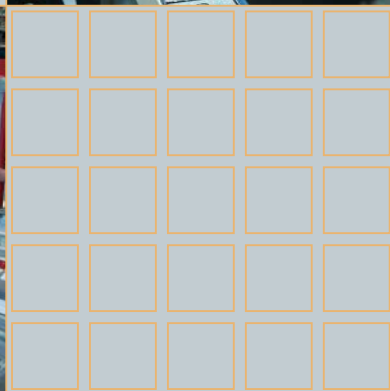
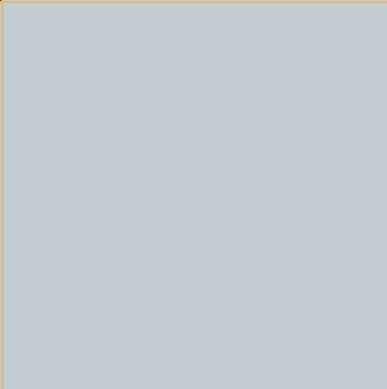
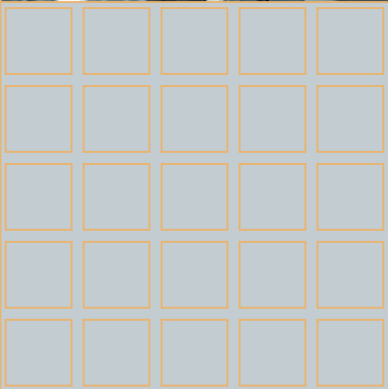
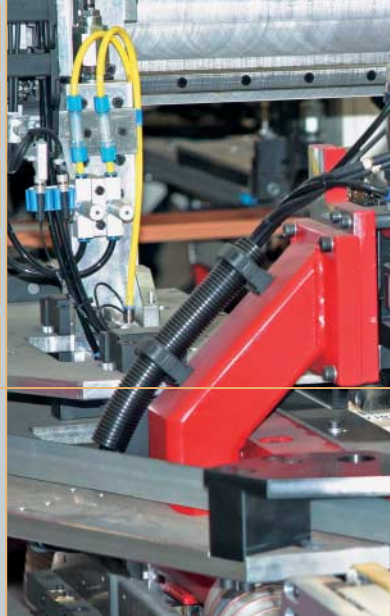
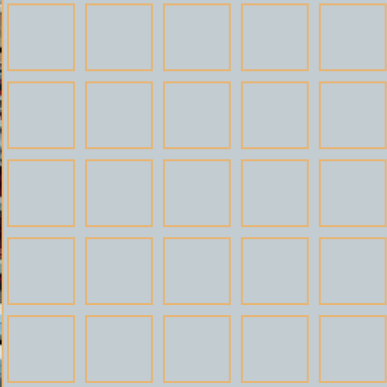

Product Examples

For latest product news please go to
www.ethercat.org/products.html

EtherCAT Technology Group 23

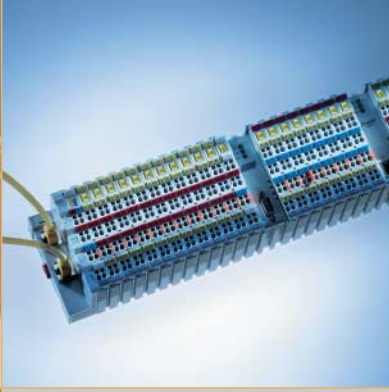



■ Contact:

EtherCAT Technology Group
Ostendstraße 196
90482 Nuremberg
Germany

Phone: +49 (0) 911 540 5620

Fax: +49 (0) 911 540 5629

info@ethercat.org

www.ethercat.org

