



TWISTERPRESSURE



Super High Pressure
Up to 3.845 mm-H₂O

APS PWM Control
(500 – 1200/1500/1800 rpm)

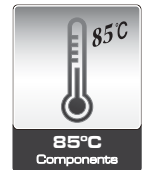

Features

- Hi-pressure blade design enhances the cooling performance
- High air pressure fan best for your CPU cooler
- World leading fan that can run at 85°C
- PWM speed control to keep your system cool and silent all the time
- Smart APS (Adjustable Peak Speed) control providing 3 peak rpm options
- Patented Twister Bearing for long lifetime and low noise
- Detachable blades for easy cleaning
- Isolator-mounts for shockproof and easy installation

Dimension (mm)

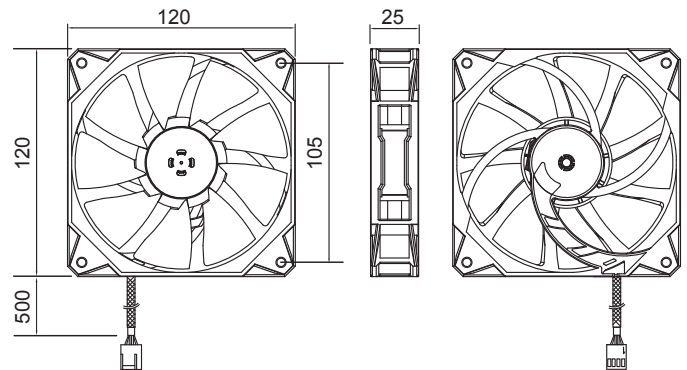

Patented APS (Adjustable Peak Speed) Control



Patented APS control allows users to adjust their preferred fan "PEAK" speed by shifting the speed control at the fan hub. The fan will run on a pre-set RPM range of customized performance between cooling performance and silent operation.

Patented Twister Bearing



Patented Twister Bearing with magnetic bearing technology, allows friction-free and self-lubricating rotation on our unique patented structure design. Such bearing design permits the fan to operate at extremely silence and for prolonged operation with industry leading MTBF of up to 160,000 hours. Twister Bearing also has a quick fan detachment design for cleaning and maintenance.

○ Blade Design

High pressure blade design is a precision engineering of the blade angle and shape calculation. The blades centralize dispersed air flow to the center of the fan and creates extremely high air pressure, high airflow while maintaining outstanding quietness.



○ Application

The high air pressure design of the TwisterPressure drives the airflow to a greater distance while maintaining the strong and concentrate wind direction to boost the cooling efficiency.

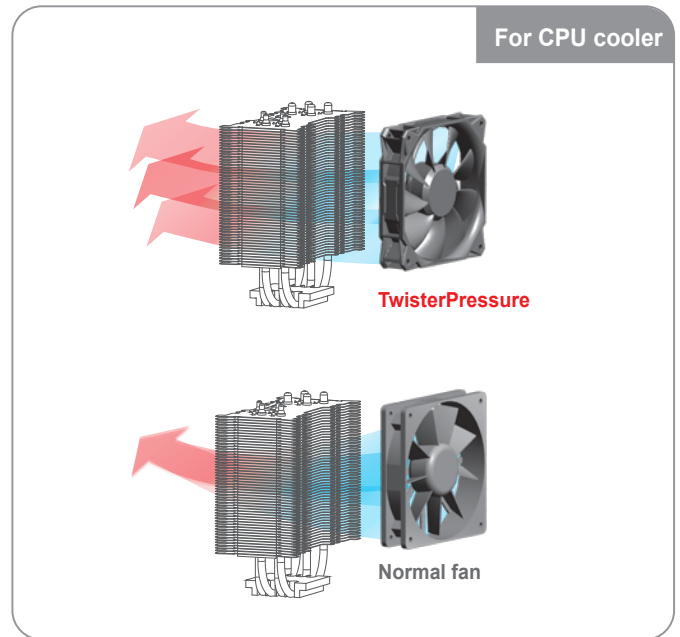
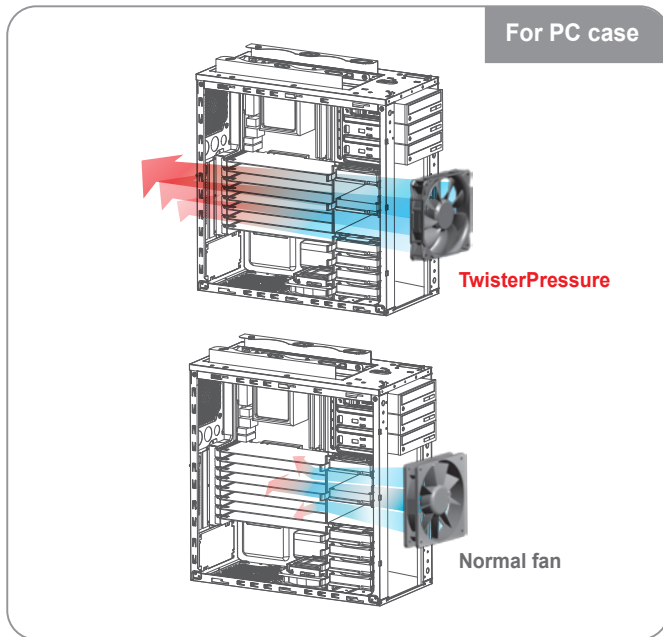

Specifications

UCTP12P			
Dimension (mm)	120 x120 x 25		
Speed Mode	Ultra Silent Mode	Silent Mode	Performance Mode
Speed (RPM)	500~1200	500~1500	500~1800
Air Flow (CFM)	23.81~55.62	23.81~69.53	23.81~79.96
Air Flow (m ³ /h)	40.45~94.50	40.45~118.13	40.45~135.85
Static Pressure (mm-H ₂ O)	0.673~1.709	0.673~2.679	0.673~3.845
Noise (dBA)	14~21	14~23	14~25
Rated Voltage (V)	12	12	12
Input Current (A)	0.12	0.15	0.30
Input Power (W)	1.44	1.8	3.6
MTBF (hour)	≥160,000		
Connector	1 x 4 pin PWM connector ; 1 x 4 pin fan power adaptor		
Safety / Certificated			