



## KEYSTONE HILOK HIGH PERFORMANCE BUTTERFLY VALVES WAFER AND LUGGED

The HiLok high performance butterfly valves offer efficient, bidirectional sealing



### FEATURES

- Cast on ISO top plate.
- Long neck for insulation service.
- External travel stop, outside of the medium area.
- Accessible packing adjustment without operator removal.
- Positive sealing which is mechanically achieved and does not rely on line pressure assistance.
- Bidirectional shut-off performance.
- Available in soft, fire-safe and metal seated.
- Long life durability due to double offset operating principle minimizing seat wear.
- Two piece shaft for maximum flow and minimum headloss.
- Quadruple shaft bearings to ensure stability during high pressure, high cycle applications.
- Fast and simple seat replacement.
- Uninterrupted gasket surface.
- Minimum 4 locating lugs per diameter.
- TA-Luft approved (optional).
- Optional groove in accordance with DIN 2512-N (up to DN 400).
- Radial, low stress disc pins.
- Available in both DIN and ASME versions.
- All valves are in compliance with PED, Category III, Module H.

### GENERAL APPLICATION

A unique valve for chemical and general industrial applications.  
Grease or silicone free valves available for special applications such as paint or oxygen systems.

### TECHNICAL DATA

Sizes:	DN 50-900 (NPS 2-36)
Temperature:	-50 °C up to +400 °C
Design criteria:	EN 12516 (DIN 3840)
Flange compatibility:	DIN PN 10-40, BS 4504, NFE 29203, ASME B16.5, ASME B16.47 series A Class 150
Face to face:	EN 558-1 series 20/25, API 609 cat-A, MSS SP 68, NFE29305
Top plate:	ISO 5211
Maximum working pressure:	DN 50 to 400: 40 bar DN 450 to 600: 25 bar DN 700 to 900: 16 bar
Material certification:	EN 10204 3.1 (DIN 50049 3.1.b)
Pressure testing:	EN 12266-1

# KEYSTONE HILOK HIGH PERFORMANCE BUTTERFLY VALVES

## DESIGN FEATURES

### NO LEAKAGE

#### 1 Seat

Tightness is unaffected by pressure changes, or changes in flow direction as the seat can move radially in its recess.

#### 2 Bottom end cover

Ensures lower stem tightness by its static seal.

#### 3 Packing system

The perfect internal tightness is obtained by a conventional packing system in expanded graphite. The excellent temperature stability ensures 100% static and dynamic tightness. Optional available in PTFE which is TA-Luft VDI 2440 approved.

### EASY ACCESSIBLE

#### 4 Standardized top plate

The integrally cast top plate in accordance with ISO 5211. The actuator can be flush mounted, eliminating the need of brackets and couplings.

#### 5 Twin column construction

Easy access to the packing system without removing the actuator.

#### 6 Extended neck

Especially designed for insulated pipework allowing easy access to the gland adjustment area, which would be located outside of the insulation area due to the elongated neck.

#### 7 Integrated locating plates

Precise centering of the valve on the pipe.

#### 8 Retaining ring

With screws outside of flange sealing zone, facilitating easy maintenance.

The uninterrupted sealing surface allows the installation of spiral wound gaskets.

### Optional end of line bidirectional feature

As standard, the lugged HiLok body design can be used as end of line unidirectional (mounted with the retaining ring upstream).

As an option, the HiLok can be provided with a reinforced retaining ring which is bolted to the valve body making the valve suitable for bidirectional end of line service.

The unique feature of this design is that the retaining ring bolts are located outside the gasket contact area. This results in an uninterrupted gasket area in both flow directions, achieving an optimum tightness at the flange connection.

Consult the sales organization for pressure/temperature rating for end of line installation.

### PERFECT SHAFT GUIDING

#### 9 Bearings

Two corrosion resistant bearings on upper and lower stem provide low friction coefficient and high load capacity. The bearings avoid any deflection of shaft at the packing level, ensuring perfect bidirectional tightness.

#### 10 Axial disc stem positioning

Shrunk on the shaft during assembly. It retains its position for the lifecycle of the valve and prevents displacement of disc in relation to the seat while being in service.

#### 11 Travel stop

Located at the mounting plate level. The travel stop is set during assembly at 90° disc angle in order to avoid any over traveling of the disc.

- The travel stop contact against the mounting plate, thus avoiding potential over-torque of the discstem.
- When actuator has been removed and valve is in service, the position of the disc is clearly shown.

#### 12 Disc to stem connection

The use of radial located disc pins removes engagement clearance and eliminates valve hysteresis.

### OPTIMIZED DESIGN

#### 13 Disc

The double eccentric disc design is optimized via the finite element method to ensure a non-contact between the seat and disc already at small angles.

### SAFETY

#### 14 Blow-out proof stem prevention

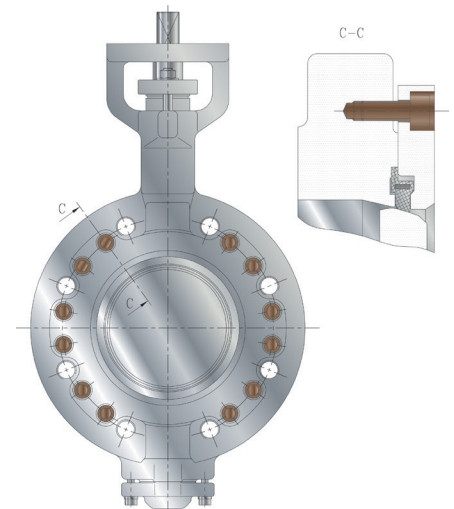
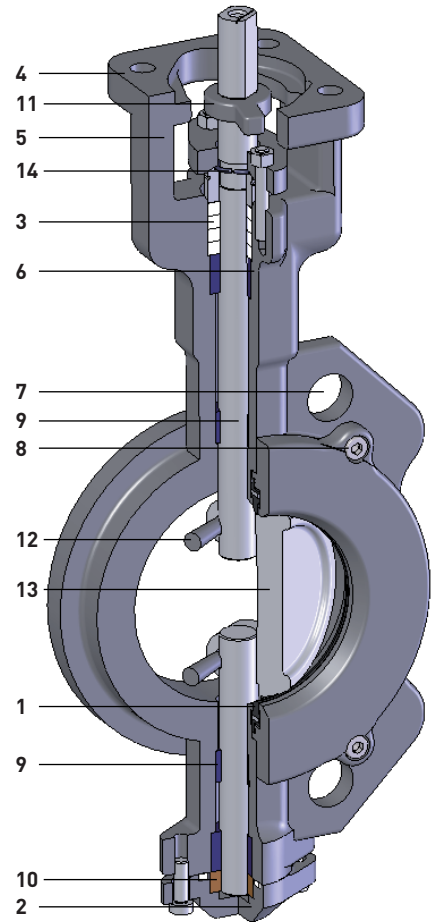

# KEYSTONE HILOK HIGH PERFORMANCE BUTTERFLY VALVES

## SEAT OPTIONS

### HILOK RTFE SEAT

The seat is made of filled RTFE in order to minimize cold flow effects at high temperatures. The combined action of seat geometry and the elastic metal insert guarantees a long lasting bidirectional tight shutoff.

Size range DN 50-900. Tightness class EN 12266-1 rate A.  
 Maximum pressure end of line: DN 50-600: 16 bar; DN 700-900: 10 bar.

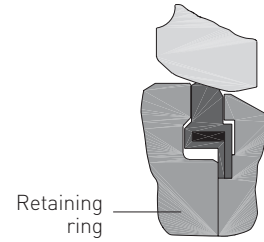

### HILOK FIRE SAFE SEAT

Size range DN 50-500. Tightness class EN 12266-1 rate A.  
 Maximum pressure end of line: DN 50-500: 16 bar.

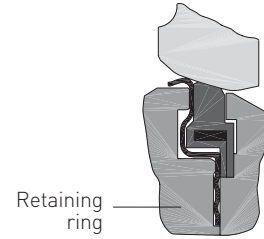

P/T DIAGRAM (HILOK RTFE AND FS)

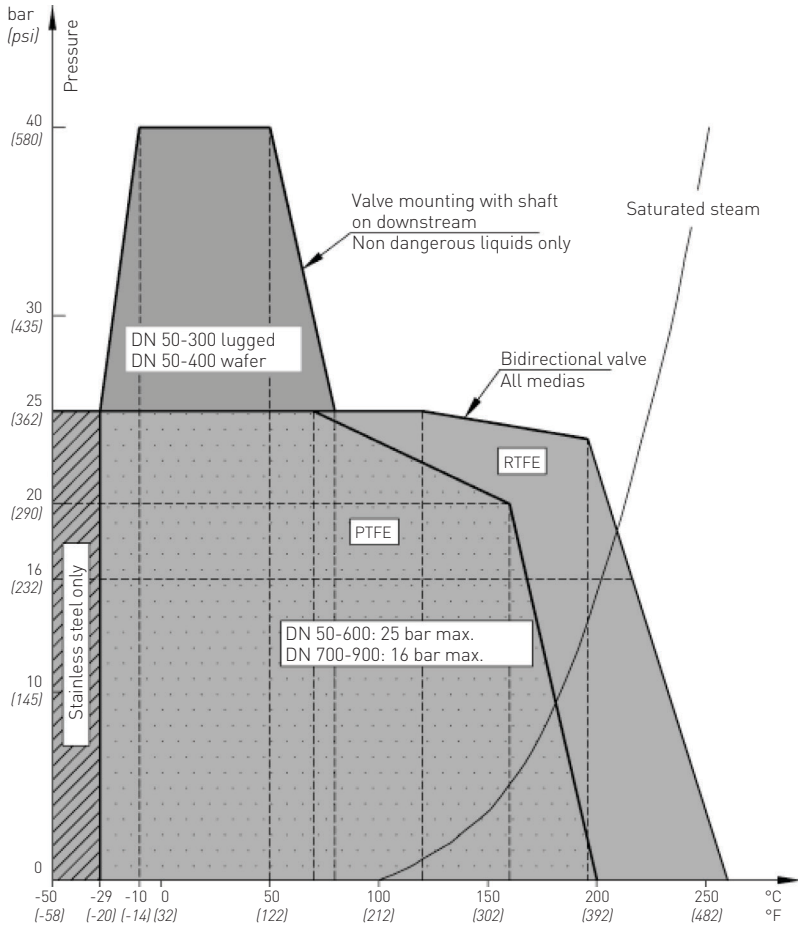

The valve has been designed according fire test standards. The standard RTFE seat is mounted with a stainless steel ring. In the event of fire, it supersedes over the RTFE seat and provides a bidirectional back-up seal, according to API 607 / BS 6755 part 2.  
 PN 40 not suited for dangerous media such as explosive, flammable, toxic or oxidizing media.

**NOTE:** HiLok can be used for end of line service mounted with the shaft downstream

# KEYSTONE HILOK HIGH PERFORMANCE BUTTERFLY VALVES

## SEAT OPTIONS

### HILOK METAL PP SEAT (PULP AND PAPER)

The valve has been specifically designed for pulp and paper applications. This seat design promotes longer life span and lower maintenance.

Size range DN 50-400. Tightness class EN 12266-1 rate D.

P/T DIAGRAM (HILOK PP SEAT)

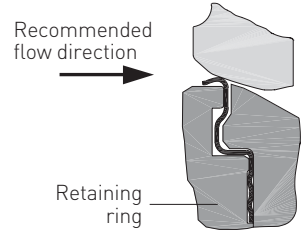
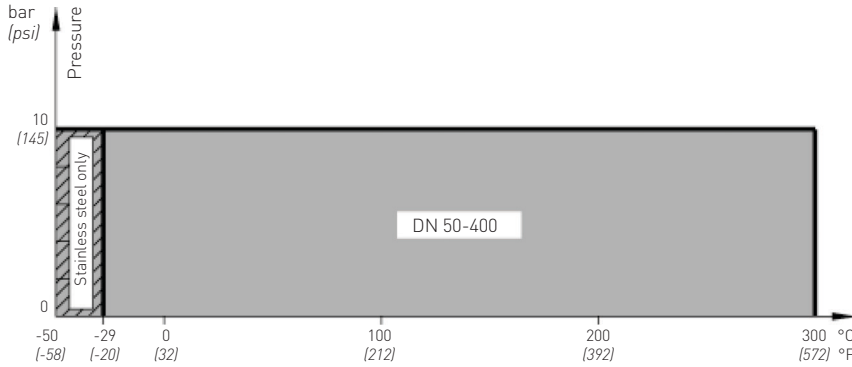

### HILOK METAL HT SEAT (HIGH TEMPERATURE)

The valve integrates a metal seat in order to be used on all applications with high pressure and high temperature.

Size range DN 50-400. Tightness class EN 12266-1 rate C.

P/T DIAGRAM (HILOK HT SEAT)

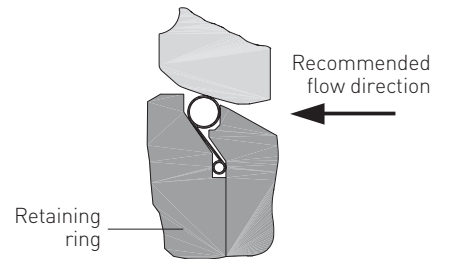
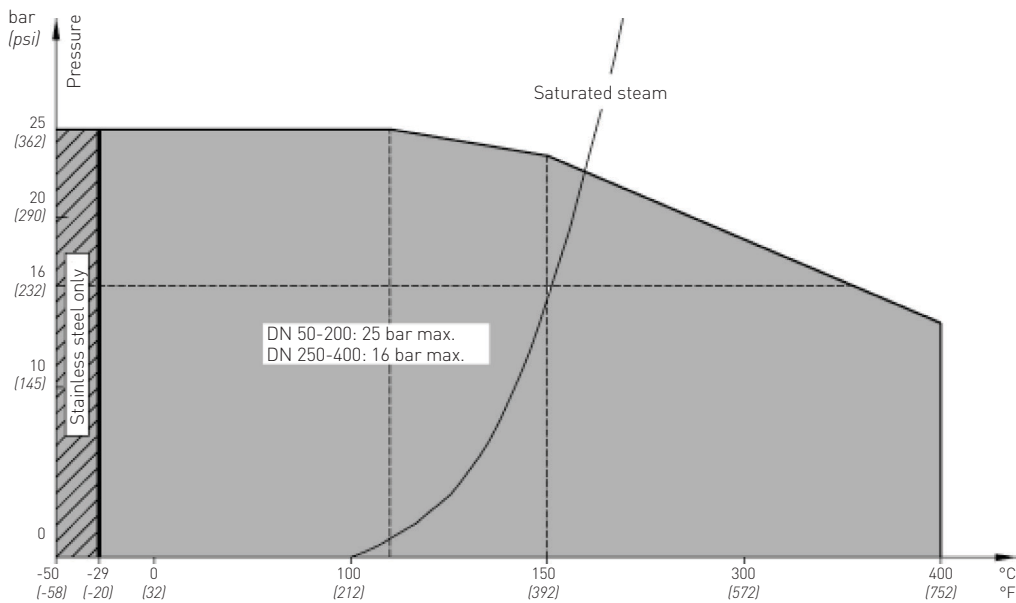

# KEYSTONE HILOK HIGH PERFORMANCE BUTTERFLY VALVES

## HYDRAULIC CHARACTERISTICS

### K<sub>v</sub>/C<sub>v</sub> VALUES

	DN																
	50	65	80	100	125	150	200	250	300	350	400	450	500	600	700	800	900
K <sub>v</sub>	115	210	320	500	820	1200	2300	3600	5200	7300	9500	12000	14800	21600	30200	40200	51200
C <sub>v</sub>	133	244	371	580	951	1392	2668	4176	6032	8468	11020	13900	17200	25000	35000	46500	59200

### BREAKAWAY TORQUE VALUES (Nm)

Seat	Condition	Valve size (DN)																
		50	65	80	100	125	150	200	250	300	350	400	450	500	600	700	800	900
RTFE	40 bar Δp <sup>[1]</sup> (shaft downstream)	36	44	60	96	150	221	416	620	920	1200	1688						
RTFE	25 bar Δp <sup>[2]</sup> (bidirectional)	27	33	45	73	115	170	320	480	720	950	1350	1700	2300	3200	4500	6000	8000
RTFE	10 bar Δp (shaft downstream)	27	33	38	62	97	143	265	390	595	760	1070	1350	1820	2750			
RTFE	7 bar Δp (shaft downstream)	27	33	34	55	85	125	230	345	520	690	970	1225	1655	2330			
Fire safe	25 bar Δp (bidirectional)	27	33	45	73	115	170	320	480	720	950	1350	1700	2300	3200			
Metal PP	10 bar Δp (shaft downstream)	27	33	45	73	115	170	320	480	720	950	1350						
Metal HT	25 bar Δp <sup>[3]</sup> (shaft upstream)	54	66	90	146	230	340	640	910	1290	1655	2350						
RTFE	Powder applications max. 25 Δp	36	44	60	96	150	221	416	620	920	1200	1688	2110	2830	3900			

1. PTFE torque values equal to RTFE
2. RTFE DN 50-600 max pressure 25 bar, DN 700-900 max pressure 16 bar
3. Metal HT DN 50-200 max. pressure 25 bar, DN 250-400 max. pressure 16 bar

### MAXIMUM ALLOWABLE SHAFT TORQUE (Nm)

Shaft material	Valve size (DN)																
	50	60	80	100	125	150	200	250	300	350	400	450	500	600	700	800	900
X20Cr13	122	122	122	297	297	743	743	1332	1957	1957	3108	6389	10793	10793	25948	25948	52851
X5CrNiCuNb 16-4	163	163	163	396	396	989	989	1772	2603	2603	4135	8497	14356	14356	34511	-	-

### K<sub>v</sub> TABLE

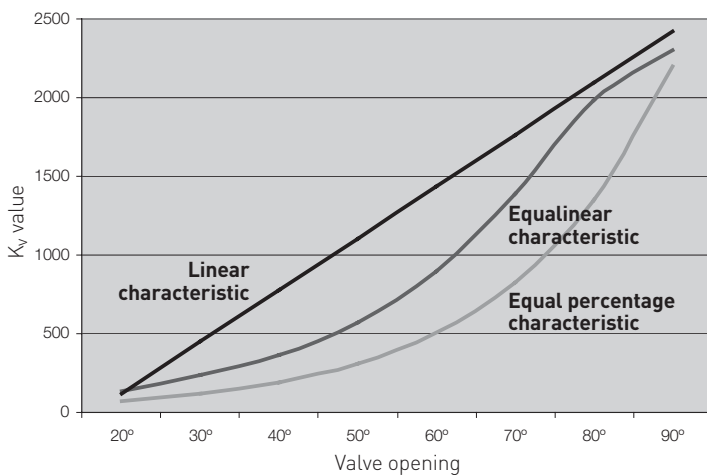

The double off set equalinear HiLok disc combines high strength, high flow capacity and excellent control characteristics with a minimum of seat wear.

The equalinear HiLok characteristic is approximately mid way between that of linear and equal percentage, making the valve suitable as a flow control valve in many industrial flow applications.

# KEYSTONE HILOK HIGH PERFORMANCE BUTTERFLY VALVES

## GENERAL DIMENSIONS BARE SHAFT VALVE

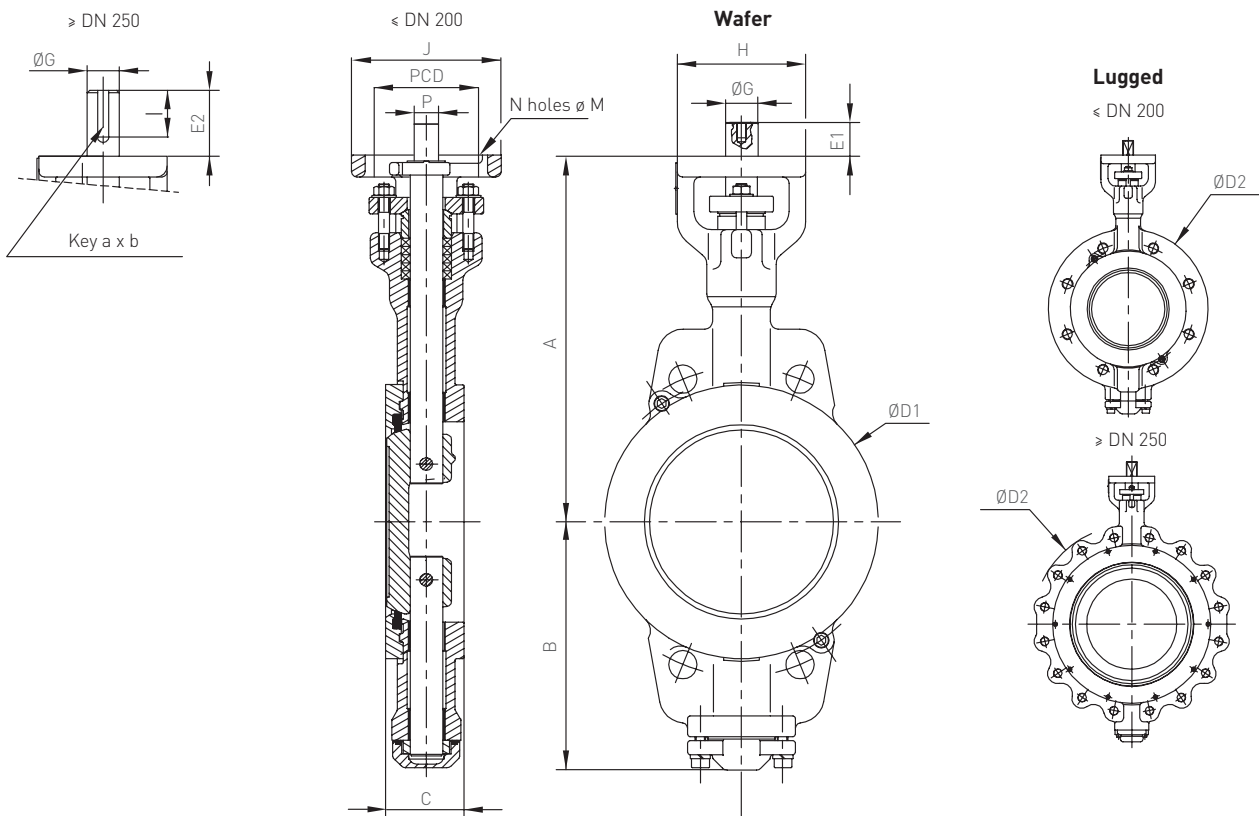

### VALVE DIMENSIONS (mm)

DN	A	B	C*	C**	ø D1	ø D2	E1	P	E2	ø G	H	J	PCD	ø M	Q	N	a	b	l	Weight (kg)	
																				Wafer	Lugged
50	175	102	43	43	97	153	25.5	11	-	14	70	80	70	9	40	4	-	-	-	3.1	4.8
65	191	116	46	46	117	173	25.5	11	-	14	70	80	70	9	51	4	-	-	-	4.5	6.9
80	197	122	46	49	130	190	25.5	11	-	14	70	80	70	9	66	4	-	-	-	4.9	7.7
100	233	149	52	56	158	225	25.5	14	-	18	100	100	102	11	90	4	-	-	-	8.2	13.7
125	245	160	56	64	188	261	25.5	14	-	18	100	100	102	11	113	4	-	-	-	9.8	17.0
150	283	193	56	70	212	294	25.5	19	-	25	100	110	102	11	141	4	-	-	-	12.5	22.5
200	307	217	60	71	267	365	25.5	19	-	25	100	110	102	11	189	4	-	-	-	21.9	33.7
250	371	251	68	76	321	420	-	-	70.0	35	132	140	125	14	236	4	10	8	60	40.4	52.5
300	399	302	78	83	372	476	-	-	70.0	35	132	140	125	14	282	4	10	8	60	54.6	77.5
350	421	324	78	92	431	542	-	-	70.0	35	132	140	125	14	326	4	10	8	60	74.4	96.5
400	453	358	102	102	484	606	-	-	80.0	40	140	149	140	18	374	4	12	8	73	97.6	133.0
450	522	392	114	114	534	662	-	-	80.0	50	-	ø 175	140	18	418	4	14	9	60	145.0	206.0
500	550	427	127	127	590	722	-	-	85.0	60	-	ø 210	165	22	467	4	18	11	80	188.0	244.0
600	634	485	154	154	689	837	-	-	85.0	60	-	ø 210	165	22	559	4	18	11	80	224.0	306.0
700	720	547	165	165	799	947	-	-	108.0	80	-	ø 300	254	18	659	8	22	14	100	269.0	450.0
800	771	598	190	-	900	1070	-	-	108.0	80	-	ø 300	254	18	-	8	22	14	100	515.0	825.0
900	878	687	241	-	1000	-	-	-	108.0	100	-	ø 350	254	18	-	8	28	16	100	850.0	1063.0

Optional square top shaft connection available on request enabling direct mounting with Emerson PremiAir pneumatic actuators.

### NOTES

- Dimensions in mm, weights in kg.
- Dimensions and weights are given as guide.
- The maximum working capability of any valve is either the body rating or the seat shut-off capability, whichever is the lower.
- K dimension in function of the required flange drilling pattern.
- C\*: Face-to-face according EN 558-1, series 20 (factory standard)
- C\*\*: Face-to-face according EN 558-1, series 25 (optional)

# KEYSTONE HILOK HIGH PERFORMANCE BUTTERFLY VALVES

## ORDERING INFORMATION

### SELECTION GUIDE

Example:	HL1	150	915	W	MA	B	00
<b>Type</b>							
<b>HL1</b>	HiLok standard face to face - series 20						
<b>HL2</b>	HiLok f.t.f EN 558 T1 - series 25						
<b>HL3</b>	HiLok f.t.f EN 558 T1 - series 16						
<b>Size (DN)</b>							
<b>50-900</b>							
<b>Trim</b>							
See material trim table							
<b>Body style</b>							
<b>W</b>	Wafer						
<b>L</b>	Lugged						
<b>Flange connection</b>							
<b>10</b>	PN 10	<b>M3</b>	Multi drill. PN 10/16				
<b>16</b>	PN 16	<b>M4</b>	Multi drill. PN 10/16/A150				
<b>25</b>	PN 25	<b>M9</b>	Multi drill. PN 10/16/25/A150				
<b>40</b>	PN 40	<b>MA</b>	Multi drill. PN 10/16/25/40/A150				
<b>A1</b>	ASME 150	<b>MB</b>	Multi drill. PN 10/16/25/40/A150/A300				
<b>Operation</b>							
<b>B</b>	Bare shaft						
<b>Variant</b>							
<b>00</b>	Standard (Any option other than standard is indicated by the option code. Consult your local Emerson contact for product identification)						

### MATERIAL TRIM TABLE

Body	Disc	Shaft	Seat	Bearing	Shaft packing	Bottom cover packing	Trim code
<b>General purpose trims</b>							
Carbon steel	Stainless steel	Stainless steel	RTFE	Carbon steel / PTFE	Graphite	Expanded graphite	<b>908</b>
Carbon steel	Stainless steel	Stainless steel	Virgin PTFE	Carbon steel / PTFE	PTFE	PTFE	<b>907</b>
Stainless steel	Stainless steel	Stainless steel	RTFE	Stainless steel / PTFE	Graphite	Expanded graphite	<b>915</b>
Stainless steel	Stainless steel	Stainless steel	Virgin PTFE	Stainless steel / PTFE	PTFE	PTFE	<b>914*</b>
Stainless steel	Stainless steel	Stainless steel	RTFE	Stainless steel / PTFE	LATTYflon®	PTFE	<b>935</b>
Stainless steel	Stainless steel	Stainless steel	Virgin PTFE	Stainless steel / PTFE	LATTYflon®	PTFE	<b>960</b>
<b>Metal seated HT (high temperature) trims</b>							
Carbon steel	Stainless steel chrome pl.	Stainless steel	Metal HT	Stainless steel	Graphite	Expanded graphite	<b>909</b>
Stainless steel	Stainless steel chrome pl.	Stainless steel	Metal HT	Stainless steel	Graphite	Expanded graphite	<b>916</b>
<b>Metal seated PP (pulp and paper) trims</b>							
Carbon steel	Stainless steel chrome pl.	Stainless steel	Metal PP	Carbon steel / PTFE	Graphite	Expanded graphite	<b>910</b>
Stainless steel	Stainless steel chrome pl.	Stainless steel	Metal PP	Stainless steel / PTFE	Graphite	Expanded graphite	<b>917</b>
<b>Fire safe seated trims</b>							
Carbon steel	Stainless steel	Stainless steel	Metal PP/RTFE	Carbon steel / PTFE	Graphite	Expanded graphite	<b>911</b>
Stainless steel	Stainless steel	Stainless steel	Metal PP/RTFE	Stainless steel / PTFE	Graphite	Expanded graphite	<b>918</b>

®LATTY is a registered trademark of Latty International S.A.

\*Trim 914 can be supplied with FDA approval. Indicate during order placement.

# KEYSTONE HILOK HIGH PERFORMANCE BUTTERFLY VALVES

## MATERIAL SPECIFICATIONS

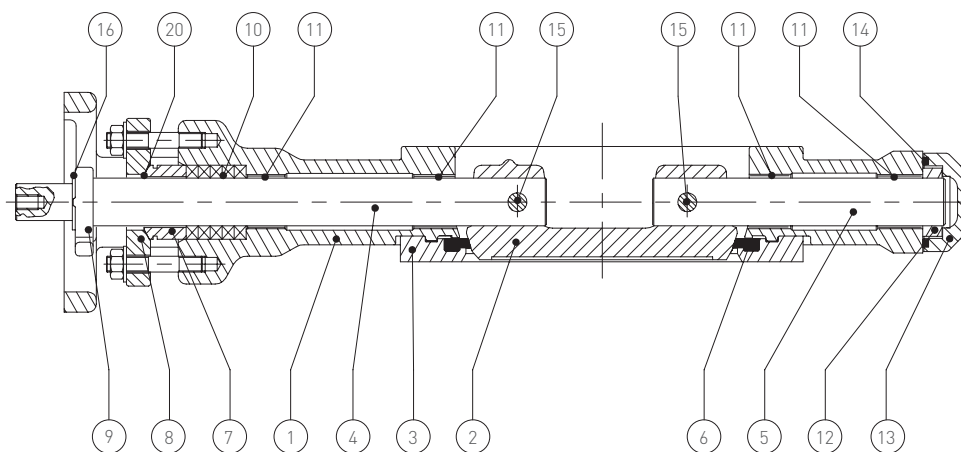

### MATERIAL SPECIFICATIONS

Part	Name	Material	Material reference	Remark	
1	Body	Carbon steel	EN GP 240 GH / A 216 Gr. WCB	DIN 1.0619	
		Stainless steel	EN GX5CrNiMo 19-11-2 / A351 Gr. CF8M	DIN 1.4408	
2	Disc	Stainless steel	EN GX5CrNiMo 19-11-2 / A351 Gr. CF8M	DIN 1.4408	
		SS chrome plated	EN GX5CrNiMo 19-11-2 / A351 Gr. CF8M	DIN 1.4408	
		Carbon steel	EN GP 240 GH / A 216 Gr. WCB	DIN 1.0619	
3	Retaining ring	Carbon steel	EN GP 240 GH / A 216 Gr. WCB	DIN 1.0619	
		Stainless steel	EN X5CrNiMo 19-11-2 / AISI 316	DIN 1.4401	Small size range
		Stainless steel	EN GX5CrNiMo 19-11-2 / A351 Gr. CF8M	DIN 1.4408	Large size range
4-5	Stem	Stainless steel	EN X20Cr13 / AISI 420	DIN 1.4021	In combination with a CS disc
		Stainless steel	EN X5CrNiCuNb 16-4 / A564 Gr.630	DIN 1.4542	In combination with a SS disc
6	Seat	Reinforced PTFE			15% graphite filled TFE
		FS PP/RTFE			15% graphite filled TFE
		PTFE			White virgin PTFE
		RTFE lip seat			25% stainless steel filled TFE
		Metal PP	ENX2CrNiMo 17-2-2 / AISI 316L	DIN 1.4404	
7	Packing gland	Carbon steel	ENX2CrNiMo 17-2-2 / AISI 316L	DIN 1.4404	
		Stainless steel	EN X12Cr13 / AISI 410	DIN 1.4406	In combination with a CS body
8	Gland bridge	Carbon steel	EN X2CrNi 19-11 / AISI 304L	DIN 1.4306	In combination with a SS body
		Carbon steel	EN C22E / AISI 105	DIN 1.1149	In combination with a CS body
9	Position indicator	Stainless steel	EN X5CrNiMo 19-11-2 / AISI 316	DIN 1.4401	In combination with a SS body
		Carbon steel	EN C22E / AISI 105	DIN 1.1149	In combination with a CS body
10	Shaft packing	Carbon steel	EN X5CrNiMo 19-11-2 / AISI 316	DIN 1.4401	In combination with a SS body
		Stainless steel	EN X5CrNiMo 19-11-2 / AISI 316	DIN 1.4401	In combination with a SS body
11	Bearing	Expanded graphite			
		Braided PTFE			
		LATTYflon®		3260LM	
12	Disc locating shoulder	Carbon steel + PTFE			In combination with a CS body
		Stainless steel + PTFE			In combination with a SS body
		Stainless steel nitrided			In combination with a SS & CS body with metal HT seat
13	Bottom end cover	Carbon steel	EN X2CrNi 19-11 / AISI 304L	DIN 1.4306	
		Carbon steel	EN C22E / AISI 105	DIN 1.1149	In combination with a CS body
14	Bottom cover packing	Stainless steel	EN X5CrNiMo 19-11-2 / AISI 316	DIN 1.4401	With SS body DN 50-200
		Stainless steel	EN GX5CrNiMo 19-11-2 / A351 Gr. CF8M	DIN 1.4408	With SS body DN 250-900
		PTFE			
15	Disc pin	Expanded graphite			
		Stainless steel	ENX2CrNiMo 17-12-2 / AISI 316L	DIN 1.4404	
16	Circlips	Carbon steel			In combination with a CS body
		Stainless steel			In combination with a SS body
17	Indication plate	Stainless steel			
18	Key	Carbon steel	EN C35E / AISI 1038	DIN 1.1180	
19	Bolts	Galvanized steel			In combination with a CS body
		Stainless steel	A2/70, A4/70, A4/80	DIN 1.4301	In combination with a SS body
20	Anti blow out ring	Stainless steel			



# KEYSTONE HILOK HIGH PERFORMANCE BUTTERFLY VALVES

## GENERAL DIMENSIONS WITH HAND LEVER

NOTCHED LEVER 'LC'  
MATERIAL: ALUMINIUM

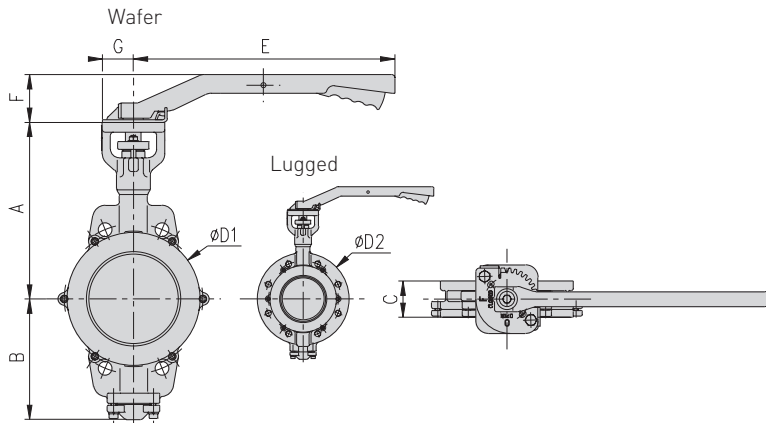

Size	Number of locking positions
DN 50-80	9
DN 100-125	9
DN 150	7

### DIMENSIONS (mm)

DN (mm)	NPS (inch)	Lever	A	B	C	$\phi D1$	$\phi D2$	E	F	G	Weights (kg)	
											Wafer	Lugged
50	2	LC 4	175	102	43	97	153	230	69	45	3.6	5.3
65	2½	LC 4	191	116	46	117	173	230	69	45	5.0	7.4
80	3	LC 4	197	122	46	130	190	230	69	45	5.4	8.2
100	4	LC 12	233	149	52	158	225	320	75	52	8.9	14.4
125	5	LC 12	245	160	56	188	261	320	75	52	10.5	17.7
150	6	LC 20	283	193	56	212	294	420	75	52	13.5	23.5

LOCKABLE LEVER 'LF'  
MATERIAL: DUCTILE IRON

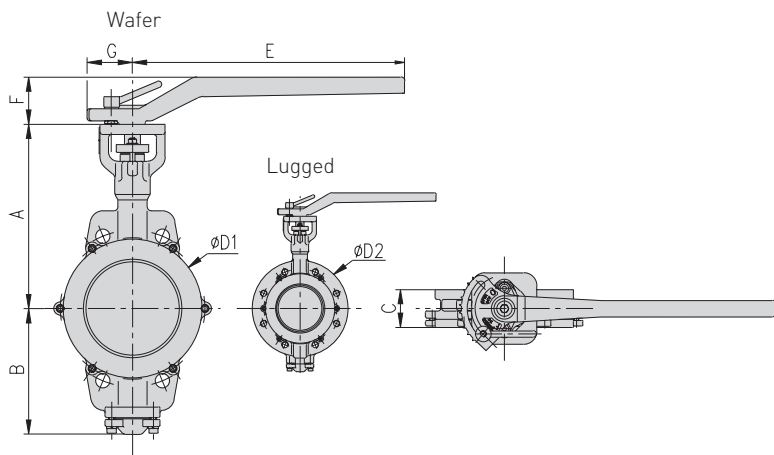

### DIMENSIONS (mm)

DN (mm)	NPS (inch)	Lever	A	B	C	$\phi D1$	$\phi D2$	E	F	G	Weights (kg)	
											Wafer	Lugged
50	2	LF 4	175	102	43	97	153	230	69	45	4.1	5.8
65	2½	LF 4	191	116	46	117	173	230	69	45	5.5	7.9
80	3	LF 4	197	122	46	130	190	230	69	45	5.9	8.7
100	4	LF 12	233	149	52	158	225	320	75	66	9.8	15.3
125	5	LF 12	245	160	56	188	261	320	75	66	11.5	18.6
150	6	LF 20	283	193	56	212	294	420	75	69	14.5	24.5
200	8	LF 20	307	217	60	267	365	420	75	69	24.0	35.7

### NOTES

- Dimensions in mm, weights in kg.
- Dimensions and weights are given as guide.
- C: Face-to-face according EN 558-1, series 20 indicated.

# KEYSTONE HILOK HIGH PERFORMANCE BUTTERFLY VALVES

## BOLTING DIMENSIONS

### WAFER TYPE

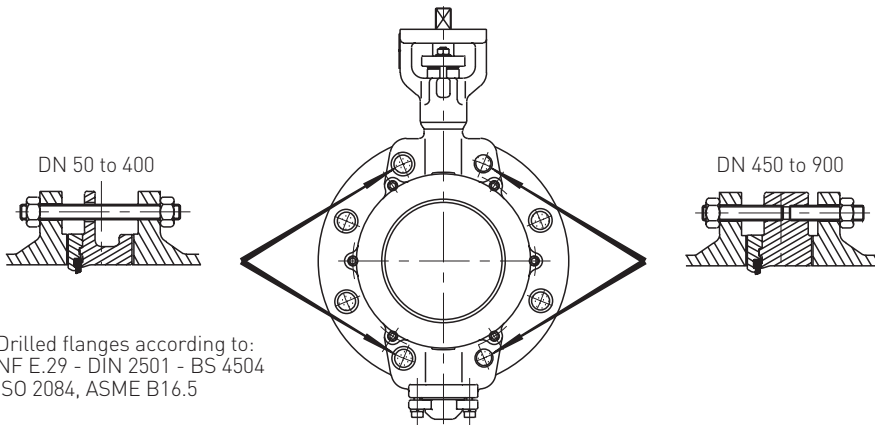

Drilled flanges according to:  
NF E.29 - DIN 2501 - BS 4504  
ISO 2084, ASME B16.5

DN	Nb.	Length			
		PN 10	PN 16	PN 20	PN 25
450	4x2	140	140	160	150
500	4x2	140	160	160	160
600	4x2	160	175	185	185
700	4x2	140	175	185	185

	DN															
	50	65	80	100	125	150	200	250	300	350	400	450	500	600	700	
<b>Nr of thru bolts</b>																
PN 10	4	4	8	8	8	8	8	12	12	16	16	*16	*16	*16	*20	
PN 16	4	4	8	8	8	8	12	12	12	16	16	*16	*16	*16	*20	
PN 20	4	4	4	8	8	8	8	12	12	12	16	*12	*16	*16	*24	
PN 25	4	8	8	8	8	8	12	12	16	16	16	*16	*16	*16	*20	
PN 40	4	8	8	8	8	8	12	12	16	16	16	*16	*16	*16	*20	
PN 50	8	8	8	8	8	12	12	16	16	20	20	*20	*20	*20	*24	
ASME 150	4	4	4	8	8	8	8	12	12	12	16	*12	*16	*16	*24	
<b>Ø of thru bolts</b>																
PN 10	M16	M16	M16	M16	M16	M20	M20	M20	M20	M20	M24	M24	M24	M27	M27	
PN 16	M16	M16	M16	M16	M16	M20	M20	M24	M24	M24	M27	M27	M30	M33	M33	
PN 20	M16	M16	M16	M16	M20	M20	M20	M24	M24	M27	M27	M30	M30	M33	M33	
PN 25	M16	M16	M16	M20	M24	M24	M24	M27	M27	M30	M33	M33	M33	M36	M39	
PN 40	M16	M16	M16	M20	M24	M24	M27	M30	M30	M33	M36	M36	M39	M45	M45	
PN 50	M16	M20	M20	M20	M20	M20	M24	M27	M30	M30	M33	M33	M33	M39	M42	
ASME 150 (UNC)	5/8"	5/8"	5/8"	5/8"	3/4"	3/4"	3/4"	7/8"	7/8"	1"	1"	**1 1/8"	**1 1/8"	**1 1/4"	-	
<b>Length of thru bolts</b>																
PN 10	120	120	120	130	130	150	150	170	170	190	230	265	265	310	310	
PN 16	120	120	120	130	130	150	150	170	190	235	250	270	290	340	340	
PN 20	120	120	130	130	150	150	170	180	180	200	235	290	320	360	390	
PN 25	120	120	130	150	150	170	170	200	200	240	250	280	310	360	360	
PN 40	120	120	130	150	150	170	180	240	240	250	300	310	360	400	400	
PN 50	120	130	150	150	170	170	190	220	240	240	280	310	340	390	435	
ASME 150	120	120	130	130	150	150	170	180	180	200	235	290	320	360	390	

\* in the 4 lugs / in addition to these thru bolts  
 \*\* bolt size threading: up to and including 1" UNC  
 > 1 1/8" 8 UN. UNC on request only

# KEYSTONE HILOK HIGH PERFORMANCE BUTTERFLY VALVES

## BOLTING DIMENSIONS

### LUGGED TYPE

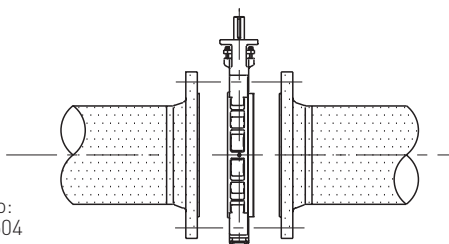

Drilled flanges according to:  
NF E.29 - DIN 2501 - BS 4504  
ISO 2084, ASME B16.5

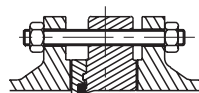

DN 50 to 400



DN 450 to 900

	DN															
	50	65	80	100	125	150	200	250	300	350	400	450	500	600	700	
<b>Nr of thru bolts</b>	4	4	8	8	8	8	8	12	12	16	16	20x2	20x2	20x2	24x2	
PN 10	4	4	8	8	8	8	8	12	12	16	16	20x2	20x2	20x2	24x2	
PN 16	4	4	8	8	8	8	8	12	12	16	16	20x2	20x2	20x2	24x2	
PN 20	4	4	4	8	8	8	8	12	12	12	16	16x2	20x2	20x2	28x2	
PN 25	4	8	8	8	8	8	12	12	16	16	16	20x2	20x2	20x2	24x2	
PN 40	4	8	8	8	8	8	-	-	-	-	-	-	-	-	-	
ASME 150	4	4	4	8	8	8	8	12	12	12	16	16x2	20x2	20x2	28x2	
<b>Ø of thru bolts</b>																
PN 10	M16	M16	M16	M16	M16	M20	M20	M20	M20	M20	M24	M24	M24	M27	M27	
PN 16	M16	M16	M16	M16	M16	M20	M20	M24	M24	M24	M27	M27	M30	M33	M33	
PN 20	M16	M16	M16	M16	M20	M20	M20	M24	M24	M27	M27	M30	M30	M33	M33	
PN 25	M16	M16	M16	M20	M24	M24	M24	M27	M27	M30	M33	M33	M33	M36	M39	
PN 40	M16	M16	M16	M20	M24	M24	-	-	-	-	-	-	-	-	-	
ASME 150 (UNC)	5/8"	5/8"	5/8"	5/8"	3/4"	3/4"	3/4"	7/8"	7/8"	1"	1"	**1 1/8"	**1 1/8"	**1 1/4"	-	
<b>Length of thru bolts</b>																
PN 10	120	120	120	130	130	150	150	170	170	190	230	140	140	160	170	
PN 16	120	120	120	130	130	150	150	170	190	235	250	140	160	175	175	
PN 20	120	120	130	130	150	150	170	180	180	200	235	160	160	185	210	
PN 25	120	120	130	150	150	170	170	200	200	240	250	150	160	185	185	
PN 40	120	120	130	150	150	170	-	-	-	-	-	-	-	-	-	
ASME 150	120	120	130	130	150	150	170	180	180	200	235	160	160	185	210	

\*\* bolt size threading: up to and including 1" UNC  
> 1 1/8" 8 UN. UNC on request only

VCTDS-00721-EN © 2012, 2022 Emerson Electric Co. All rights reserved 03/22. Keystone is a mark owned by one of the companies in the Emerson Automation Solutions business unit of Emerson Electric Co. The Emerson logo is a trademark and service mark of Emerson Electric Co. All other marks are the property of their prospective owners.

The contents of this publication are presented for informational purposes only, and while every effort has been made to ensure their accuracy, they are not to be construed as warranties or guarantees, express or implied, regarding the products or services described herein or their use or applicability. All sales are governed by our terms and conditions, which are available upon request. We reserve the right to modify or improve the designs or specifications of such products at any time without notice.

Emerson Electric Co. does not assume responsibility for the selection, use or maintenance of any product. Responsibility for proper selection, use and maintenance of any Emerson Electric Co. product remains solely with the purchaser.

[Emerson.com/FinalControl](https://www.emerson.com/FinalControl)

---