

2/2 VALVES PRESSURE OPERATED MOTORISED OPERATED

Product Index



Function	ΔP		Temperature		Pipe connections	Series	Page
	min. (bar)	max. (bar)	min. (°C)	max. (°C)			
MOTORISED OPERATED							
STAINLESS STEEL BODY							
-	0	6	-10	+90/+145	Motorised valves	E290	9
PRESSURE OPERATED							
Ranges/Technical information/Applications						290/390/298/398	1
BRONZE BODY							
NC-NO	0	16	-10	+184	Threaded ports (IEC 61508)	E290	15
NC-NO	0	16	-10	+184	Flanged (IEC 61508)	T290	35
NC-NO	0	16	-10	+184	Threaded ports	165 (AD/TBT)	77
NC	0	16	-10	+184	Flanged	165 (AD/BBT)	79
STAINLESS STEEL BODY							
NC-NO	0	16	-10	+184	Threaded ports	1/2..2 1/2	E290 15
NC-NO	0	16	-10	+184	External thread (IEC 61508)	1/2..1	U290 23
NC-NO	0	16	-10	+184	External thread, food connections DIN 11851 (IEC 61508)	RD 28x1/8 .. 44x1/6	Y290 25
NC-NO	0	16	-10	+184	Clamp / butt welding (IEC 61508)	DN 10..65	S290 27
NC-NO	0	40	-25	+250	Threaded ports (IEC 61508)	1/2 .. 2	E298 53
NC-NO	0	40	-25	+250	Flanged (DIN and ANSI Class 300) (IEC 61508)	DN 15..50	T298 57
NC-NO	0	40	-25	+250	Socket welding ends (IEC 61508)	DN 15..50	S298 61
NC-NO	0	40	-20	+100	Coaxial	3/8 .. 1	287 75
STAINLESS STEEL BODY, IN CONFORMITY WITH REGULATION (EC) no. 1935-2004							
NC-NO	0	16	-10	+184	Threaded ports	1/2..2 1/2	E290 19
NC-NO	0	16	-10	+184	Clamp / butt welding (IEC 61508)	DN 10..65	S290 31
BRASS BODY							
NC-NO	0	40	-20	+100	Coaxial	3/8 .. 1	287 75
ACCESSORIES AND OPTIONS							
Options and accessories for series 290/390 (standard/ATEX 2014/34/EU)						www.asco.com / www.asco.com	37/43
Options and accessories for series 298/398 (standard/ATEX 2014/34/EU)						www.asco.com / www.asco.com	65/67
Air/oil exchanger for type AD valves						218	81
SOLENOID PILOT VALVES							
Valve piloting solutions						290/390	47
290/390: 189/banjo and 356 solenoid valves - 32, 50 and 63 mm operators / 356 and 314 solenoid valves - 90 and 125 mm operators						www.asco.com / www.asco.com	49/51
298/398: 356 solenoid valves - 80 and 100 mm operators / 314 and 356 solenoid valves - 150 and 200 mm operators						www.asco.com / www.asco.com	71/73
314 solenoid valves - AD valve operators						AD	83

(Potentially explosive atmospheres, see page: IV)

All leaflets are available on: www.asco.com

Pressure Operated Valves (2/2) / Motorised Operated Valves (2/2) - I

pipe connections				body material		max. operating pressure differential (bar)		max. allowable pressure (bar)		fluid temperature range		power consumption		series	I&M Sheet	page													
- internal thread - external thread - butt welding - external thread DIN 11851 - flanged - clamp - socket welding ends	- 10	- 15	- 20	- 25	- 32	- 40	- 50	- 65	- 80	- 100	- 125	- 150	DN	min. operating pressure differential (bar)	air, inert gases	water, oil liquids	vacuum (mbar)	hot water	steam	superheated water	max. allowable pressure (bar)	min. (°C)	max. (°C)	mean (W)	hold	series	I&M Sheet	page	
	3/8 (RD28x1/8)	1/2 (RD34x1/8)	3/4 (RD44x1/6)	1	1 1/4	1 1/2	2	2 1/2	3					10 ↓ 65	0	16 ↓ 7	10 ²	16 ↓ 7	10 ↓ 7		16	-10	+184	-	-	E290		15	
														10 ↓ 65	0	16 ↓ 7	10 ²	16 ↓ 7	10 ↓ 7		16	-10	+184	-	-	E290		19	
														10 ↓ 20	0	16	10 ²	16	10		16	-10	+184	-	-	Y290		25	
														10 ↓ 65	0	16 ↓ 7	10 ²	16 ↓ 7	10 ↓ 7		16	-10	+184	-	-	S290		27	
														10 ↓ 65	0	16 ↓ 7	10 ²	16 ↓ 7	10 ↓ 7		16	-10	+184	-	-	S290		31	
														25 ↓ 50	0	16 ↓ 7	16 ↓ 7	-	16 ↓ 7	10 ↓ 7		16	-10	+184	-	-	T290		35
														15 ↓ 50	0	40	40	10 ²	40	-	40	-25	+250	-	-	E298		53	
														15 ↓ 50	0	-	-	-	24	24	40	-25	+223	-	-	T298		57	
														15 ↓ 50	0	16	16		16	10		16	-10	+184	-	-	165		77 (AD/TBT)
														10 ↓ 25	0	40 12	40 12		40 12	-		-	-20	+100	-	-	287		75 (coaxial)

00046GB-2018/R01
Availability, design and specifications are subject to change without notice. All rights reserved.

PRESSURE OPERATED VALVES

		I&M Sheet	DN	group II								
				dusts zone 22	gas zone 2			dusts zone 21	gas zone 1			dusts zones 0-20
page	series			IIA	IIB	IIC	IIA	IIB	IIC			
SERIES 290 VALVES ATEX 2014/34/EU (see page: 43)												
15	E290		10 → 65									-
19	E290		10 → 65									-
23	U290		10 → 20									-
25	Y290		10 → 20									-
27	S290		10 → 65									-
31	S290		10 → 65									-
35	T290		25 → 50									-
SERIES 298 VALVES ATEX 2014/34/EU (see page: 67)												
53	E298		15 → 50									-
57	T298		15 → 50									-
61	S298		15 → 50									-
SERIES 287 VALVES ATEX 2014/34/EU (see page: 75)												
75	287		10 → 25									-
TYPE AD VALVES ATEX 2014/34/EU (see pages: 77/79)												
77	165 - AD/TBT		15 → 50									-
79	165 - AD/BBT		15 → 80									-

SOLENOID PILOT VALVES

 		operators (See Explosionproof Solenoids section)		group II							
				dusts zone 22	zones 2 - 22	gas / dusts zones 1 - 21					
page	series	power coil (W)		3 D Ex tc	IIC T115°C Dc IP65X	2 G Ex db 2 D Ex tb	IIC T6..T4 Gb /IIC Db IP66/67	2 G Ex eb mb 2 D Ex tb	IIC T6..T3 Gb /Ex tb IIC Db IP66/67	2 G Ex mb 2 D Ex mb	V1035 (IIC T5..T3 Gb /IIC Db IP67)
		AC (~)	DC (=)	SG (XM5)	SG (C25)	SG (MXX-I)	(WS)NF (MXX)	(WS)EM (MXX)		PV (EM5)	PV (EMXX)
49	189 banjo	2,5	3								4/3
	356	4	6,9								4/6,9
51	356	5	6,9								4/6,9
	314	10,1	11,6				10,5	10,5			10,5
71	356	4	6,9				11,2	11,2			11,2
73	314	10,1	11,6				10,5	10,5			10,5
83	314	10,1					11,2	11,2			11,2
			11,6				10,5	10,5			10,5
			11,6				11,2	11,2			11,2

Reliability and long service life

Anti-waterhammer design

Backpressure resistant

Angle-seat valves

series 290-390

- Excellent flow rate
- PN16
- Max. fluid temperature +180°C
- Max. ambient temperature +60°C

Easy assembly
Operator rotatable through 360° to position the piloting port

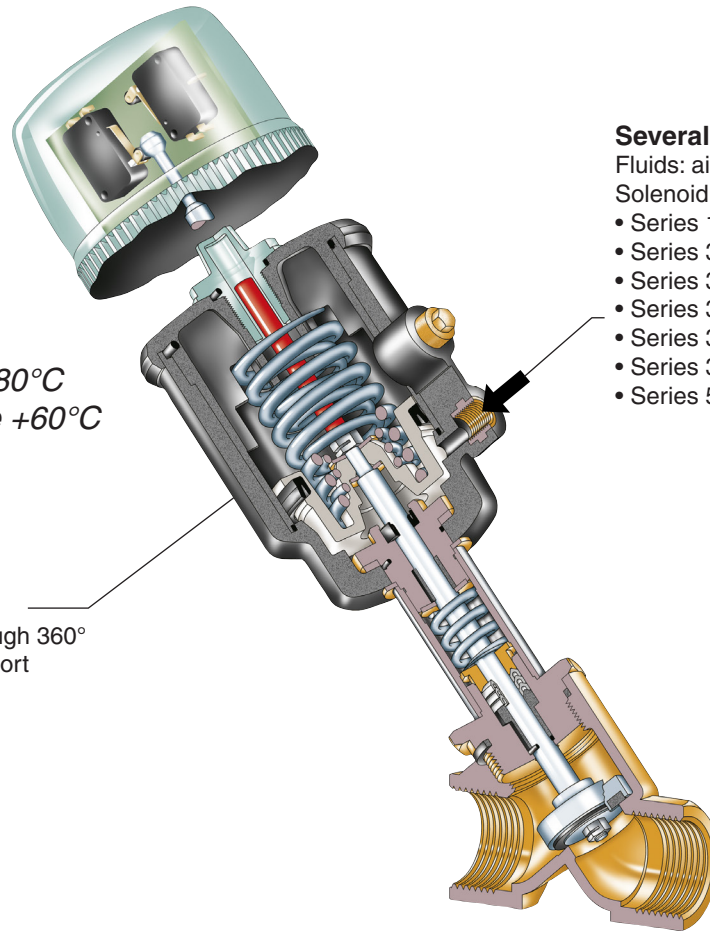

- Several piloting choices:**
Fluids: air or water from 1,5 to 10 bar
Solenoid pilot valves:
- Series 189 Banjo Ø 1,2 mm
 - Series 356 Ø 1,6 mm G1/8-1/4
 - Series 314 Ø 3,2 mm
 - Series 325 Ø 1,2 mm
 - Series 314 Ø 1,2 - 2,4 et 3,2 mm
 - Series 320 Ø 3,2 mm
 - Series 551 NAMUR with interface

Globe valves

series 298-398

- Thermal shock resistant
- PN40
- Max. fluid temperature +250°C
- Max. ambient temperature +180°C
- 3/2 Universal
- Simple and easy maintenance, fully disassemblable valve

Bi-directional fluid flow
Pressure can be applied to any orifice as required by the process

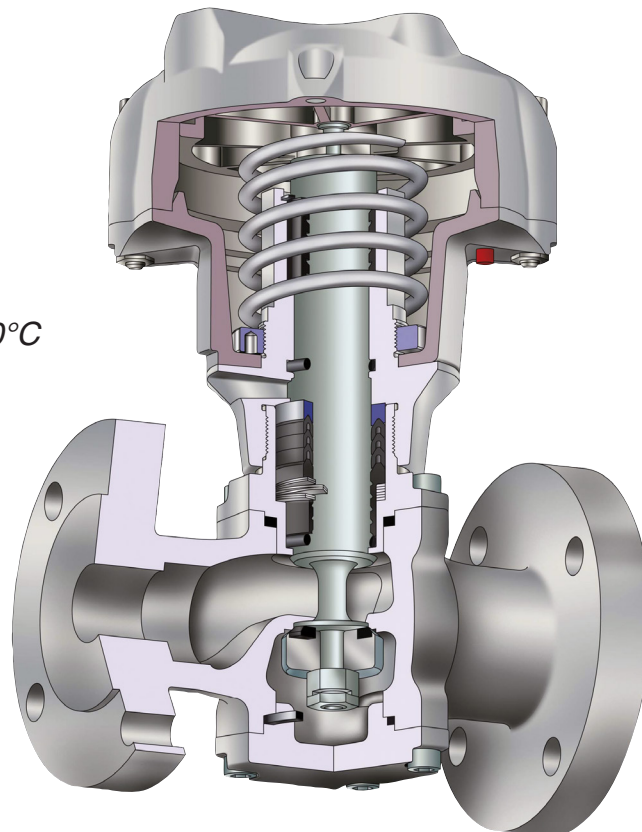

00047GB-2017/R01
Availability, design and specifications are subject to change without notice. All rights reserved.

A wide range of valves for all fluid applications

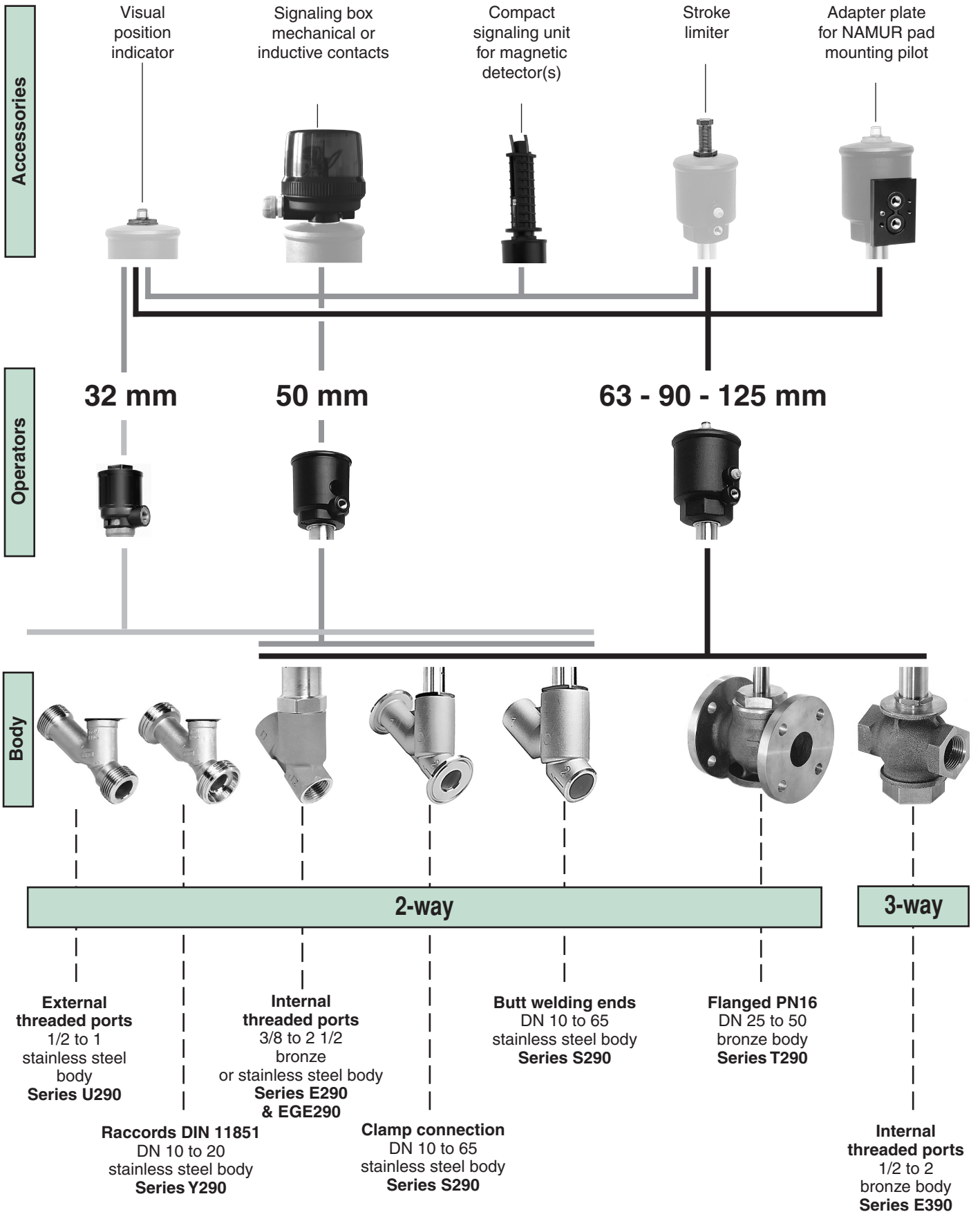

For exact material selection and combinations, refer to the appropriate catalogue pages.

A wide range of valves for all fluid applications

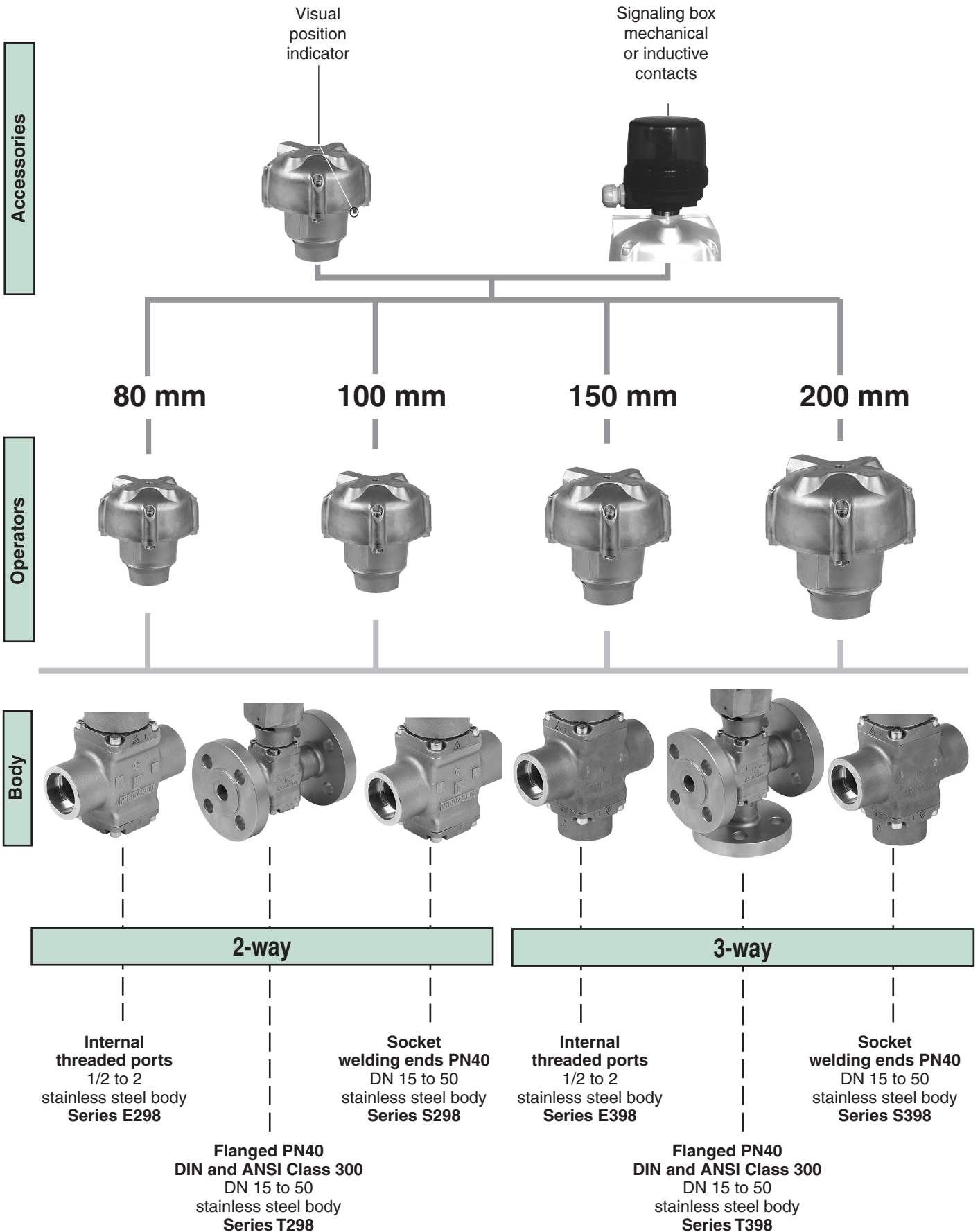









00047GB-2017/R01
Availability, design and specifications are subject to change without notice. All rights reserved.

For exact material selection and combinations, refer to the appropriate catalogue pages.

All leaflets are available on: www.asco.com

GENERAL SPECIFICATIONS





2/2 VALVES (Functions NC - NO)						
series		E290	E290	U290	Y290	S290
connection		internal thread	internal thread	ext. thread	DIN 11851	Clamp / butt welding ends
body		1/2 to 2 1/2 bronze	3/8 to 2 1/2 stainless steel ⁽¹⁾	1/2 to 1 st. steel ⁽¹⁾	DN 10 to 20 all AISI 316L	DN 10 to 65 stainless steel ⁽¹⁾
FLUIDS:	neutral aggressive steam (10 bar max.)	• • •	• • •	• • •	• • •	• • •
FLUID TEMPERATURE		-10°C to +184°C				
DIFFERENTIAL PRESSURE		0 - 16 bar				
MAXIMUM ALLOWABLE PRESSURE		16 bar				
AMBIENT TEMPERATURE		-10°C to +60°C				
PILOT FLUID		filtered air or water				
PILOT FLUID TEMPERATURE		-10°C to +60°C				
OPERATOR		32, 50, 63, 90, 125 mm				
PILOT PRESSURE		2,5 / 4 to 10 bar ⁽²⁾				
	NC (fluid entry under disc)	see page: 7 ⁽²⁾				
	NO (fluid entry under disc)	see page: 7 ⁽²⁾				
	NC (fluid entry above disc)	see page: 7 ⁽²⁾				
CATALOGUE PAGE		15 (www.asco.com)	15 (www.asco.com) 19 (www.asco.com)	23 (www.asco.com) 25 (www.asco.com)	27 (www.asco.com) 31 (www.asco.com)	27 (www.asco.com) 31 (www.asco.com)





2/2 - 3/2 VALVES (Functions NC - NO)						
series		T290	E390	EGE290		proportional
connection		2/2, flanged	3/2, internal thread	gas service		
body		DN 25 to 50 bronze	1/2 to 2 bronze	1/2 to 2 bronze / stainless steel	3/8 to 2 acier inox	1/2 to 1 1/2 acier inox
FLUIDS:	neutral steam (10 bar max.) combustible gas (EN 161)	• • •	• • •	• • •	• • •	• • •
FLUID TEMPERATURE		-10°C to +184°C	-10°C to +184°C	-10°C to +60°C	-10°C to +60°C	0°C to +50°C
DIFFERENTIAL PRESSURE		0 - 16 bar	0 - 16 bar	0 - 10 bar	0 - 1 bar	1 bar
MAXIMUM ALLOWABLE PRESSURE		16 bar	16 bar	-	-	16 bar
AMBIENT TEMPERATURE		-10°C to +60°C	-10°C to +60°C	-	-	0°C to +50°C
PILOT FLUID		filtered air or water	filtered air or water	air		air/inert gas
PILOT FLUID TEMPERATURE		-10°C to +60°C	-10°C to +60°C	-10°C to +60°C		0°C to +50°C
OPERATOR		63, 90, 125 mm	63, 90, 125 mm	63 mm	32, 63 mm	63 mm
PILOT PRESSURE		2,5 / 4 to 10 bar ⁽²⁾	3 / 5 to 10 bar ⁽²⁾	-	5,5/3,5..9 bar	5 to 8 bar
	NC (fluid entry under disc)	see page: 7 ⁽²⁾	see page: 7 ⁽²⁾	-	-	-
	NO (fluid entry under disc)	see page: 7 ⁽²⁾	-	5 à 9 bar	-	-
	NC (fluid entry above disc)	see page: 7 ⁽²⁾	-	-	-	-
		Pressure Operated Valves (2/2)	Pressure Operated Valves (3/2)	Combustible Gas & Oil (3/2)		
		▼	▼	entry above the disc	entry under the disc	
CATALOGUE PAGE		35 (www.asco.com)	www.asco.com	www.asco.com	www.asco.com	www.asco.com

⁽¹⁾ All stainless steel AISI 316L versions on request.

⁽²⁾ Pilot pressure lower than indicated minimum, contact us.

GENERAL SPECIFICATIONS

2/2 VALVES (Functions NC - NO)					
series		E298	T298	S298	proportional
connection		internal thread	flanged	socket welding ends	E298/T298/W298
body		PN40	PN40, DIN and ANSI Class 300	PN40	all
		1/2 to 2	DN 15 to 50	DN 15 to 50	PN40
		stainless steel	stainless steel	stainless steel	stainless steel
FLUIDS:	neutral	•	•	•	•
	aggressive	•	•	•	•
	superheated water	•	•	•	•
	steam (10 bar max.)	•	•	•	•
FLUID TEMPERATURE			-10°C to +250°C		-10°C to +233°C
DIFFERENTIAL PRESSURE			0 - 40 bar		0 - 40 bar
MAXIMUM ALLOWABLE PRESSURE			40 bar		40 bar
ALLOWABLE BACKPRESSURE			up to 40 bar		-
AMBIENT TEMPERATURE			-25°C to +180°C (autoclavable valve)		0°C to +50°C
PILOT FLUID			filtered air		filtered air
PILOT FLUID TEMPERATURE			-10°C to +60°C		0°C to 20°C
OPERATOR			80, 100, 150, 200 mm		80, 100, 150, 200 mm
PILOT PRESSURE			max. 10 bar ⁽¹⁾		4 to 8 bar
					Proportional Valves
					▼
CATALOGUE PAGE		53 (www.asco.com)	57 (www.asco.com)	61 (www.asco.com)	www.asco.com

3/2 VALVES (U, mixer / distributor functions)					
series		E398	T398	S398	proportional
connection		internal thread	flanged	socket welding ends	E398/T398/W398
body		PN40	PN40, DIN and ANSI Class 300	PN40	all
		1/2 to 2	DN 15 to 50	DN 15 to 50	PN40
		stainless steel	stainless steel	stainless steel	stainless steel
FLUIDS:	neutral	•	•	•	•
	aggressive	•	•	•	•
	superheated water	•	•	•	•
	steam (10 bar max.)	•	•	•	•
FLUID TEMPERATURE			-10°C to +250°C		-10°C to +233°C
DIFFERENTIAL PRESSURE			0 - 40 bar		0 - 40 bar
MAXIMUM ALLOWABLE PRESSURE			40 bar		40 bar
AMBIENT TEMPERATURE			-25°C to +180°C		0°C to +50°C
PILOT FLUID			filtered air		filtered air
PILOT FLUID TEMPERATURE			-10°C to +60°C		0°C to 20°C
OPERATOR			80, 100, 150, 200 mm		80, 100, 150, 200 mm
PILOT PRESSURE			max. 10 bar ⁽¹⁾		4 to 8 bar
			Pressure Operated Valves		Proportional Valves
			(3/2)		
		▼	▼	▼	▼
CATALOGUE PAGE		www.asco.com	www.asco.com	www.asco.com	www.asco.com

⁽¹⁾ min. pilot pressure: See pilot pressure graphs on the respective catalogue page.

Selection and operation of a valve depend on two parameters:

- The maximum differential pressure (ΔP) across the valve in closed position
- The minimum pilot pressure necessary to control the valve

Series 290 - 390 valves can be equipped with diameter 32, 50, 63, 90 or 125 mm operators.

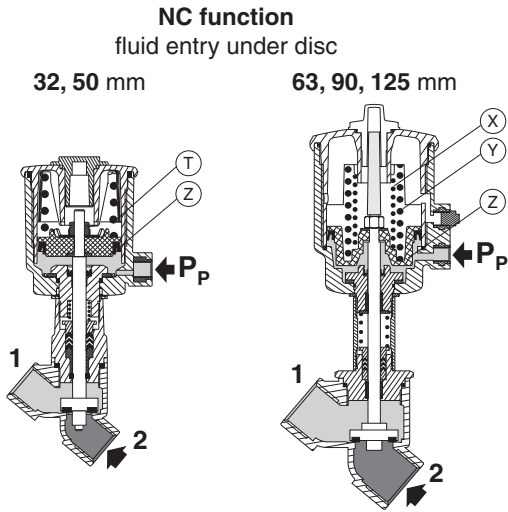

The valve is kept in the closed position by spring (T) (X) and/or (Y). It is opened by pilot pressure (Pp) under the piston (Z).

The operators are standard available as follows:

operators	return spring	pilot pressure (bar)		range of applications
		min.	max.	
32 - 50	T	4	10	high ΔP typical applications
63 - 90 - 125	X + Y	4	10	

To meet the requirements of different applications, 63-90-125 mm operators are available in two other versions:

63 - 90 - 125	Y	2,5	10	average ΔP low pilot pressure
	X	1,5	10	low ΔP very low pilot pressure

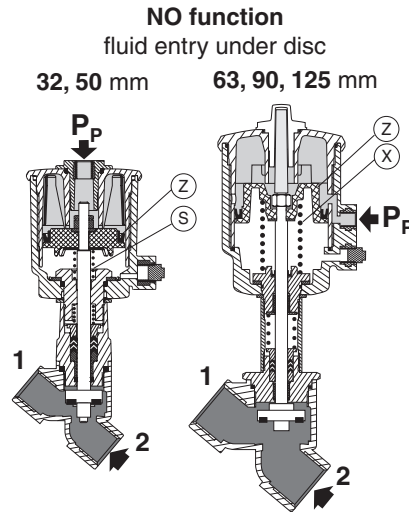

The valves are kept in the open position by return spring (S) or (X).

The valve is closed by pilot pressure (Pp) on piston (Z).

In the closed position, the pilot pressure must overcome the force of the return spring and that created by the ΔP under the disc.

The minimum pilot pressure varies as a function of the ΔP to which the valve is subjected.

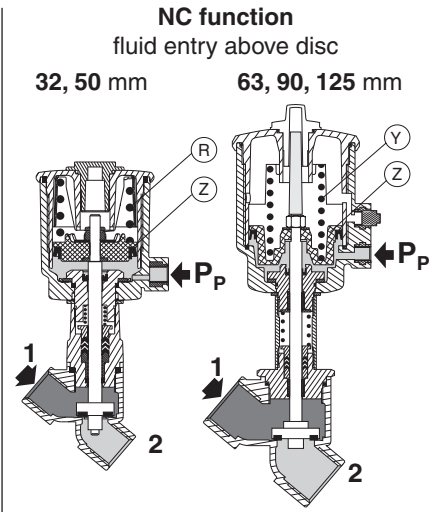

This function is recommended for steam systems (184°C max.) with high cycling rates.

Not to be used with liquids as waterhammer may occur.

Valves are maintained in the closed position by spring (R) or (Y).

The valve is opened by pilot pressure (Pp) under piston (Z). The pilot pressure must overcome the force of the return spring and that generated by the ΔP on the disc.

The minimum pilot pressure varies as a function of the ΔP to which the valve is subjected.

Series 298 - 398 valves can be equipped with diameter 80, 100, 150 or 200 mm operators.

The minimum pilot pressure varies as a function of the ΔP to which the valve is subjected. Low pilot pressure operation is standard on all 298 - 398 valves.

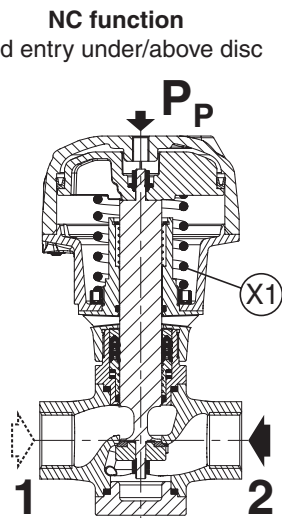

The valve is kept in the closed position by spring (X1). It is opened by pilot pressure (Pp).

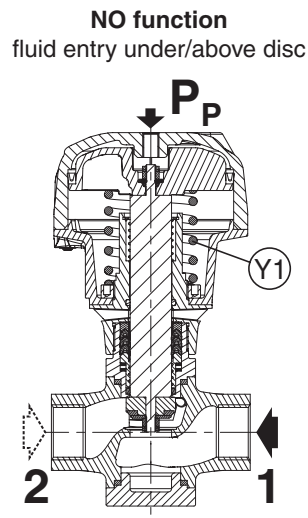

The valves are kept in the open position by return spring (Y1). It is closed by pilot pressure (Pp).

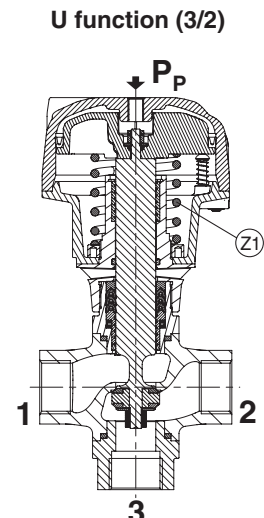

The valves are held in position by return spring (Z1). Pilot pressure (Pp).

SELECTION OF THE MINIMUM PILOT PRESSURE

series 290 / 390

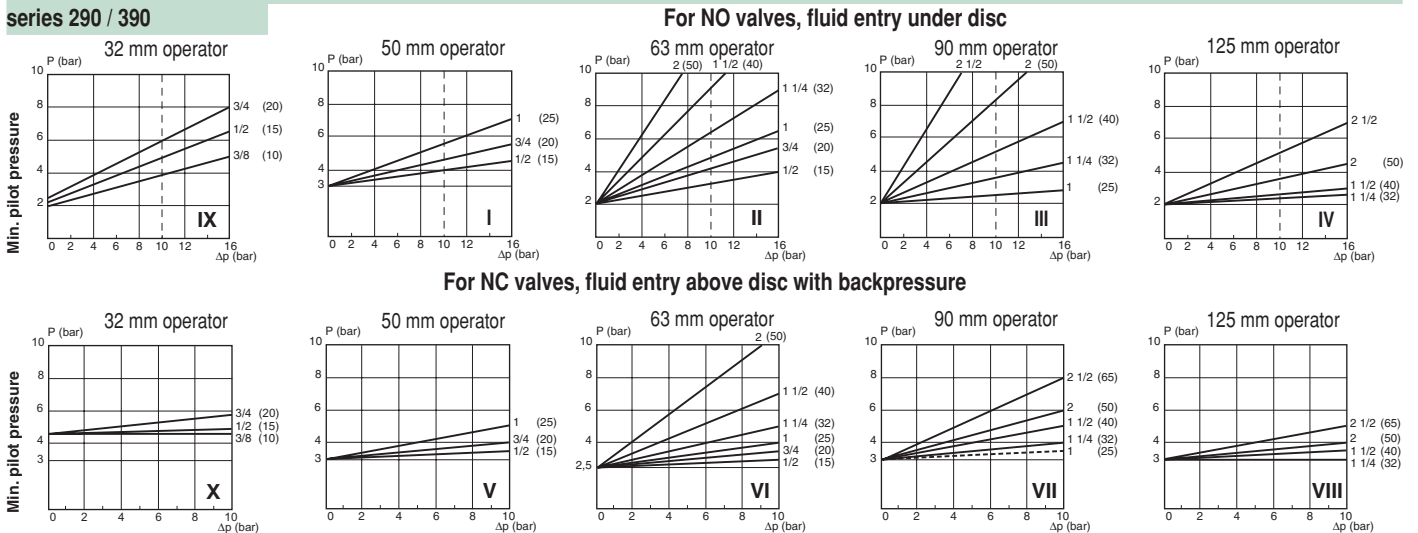

series 298 / 398

See graphs on pages: **2/2: 53** (www.asco.com), **57** (www.asco.com), **61** (www.asco.com)
3/2: 3 (www.asco.com), **7** (www.asco.com), **11** (www.asco.com)

SELECTION OF PILOT VALVE TYPE FOR REQUIRED RESPONSE TIMES

Response times of valves depend on the Kv of the pilot valve or positioner used and the size of the valve, as shown in the following tables.

series 290 / 390	Response time (in seconds) for NC valve series 290/390 (6 bar pilot air)														
	32 mm operator			50 mm operator			63 mm operator			90 mm operator			125 mm operator		
	Ø (DN)	pilots		pilots			pilots			pilots			pilots		
3/8 (10)	0,05	-	0,01	-	-	-	-	-	-	-	-	-	-	-	-
1/2 (15)	0,05	-	0,01	0,14	0,09	0,9	0,9	0,19	0,16	-	-	-	-	-	-
3/4 (20)	0,05	-	0,01	0,14	0,09	0,9	0,9	0,23	0,23	0,22	0,22	0,22	0,22	0,22	0,22
1 (25)	-	-	-	0,17	0,10	0,9	0,9	0,37	0,32	0,52	0,52	0,52	0,52	0,52	0,52
1 1/4 (32)	-	-	-	-	-	-	-	0,37	0,32	0,52	0,52	0,52	0,52	0,52	0,52
1 1/2 (40)	-	-	-	-	-	-	-	0,37	0,32	0,52	0,52	0,52	0,52	0,52	0,52
2 (50)	-	-	-	-	-	-	-	0,37	0,32	0,52	0,52	0,52	0,52	0,52	0,52
2 1/2 (65)	-	-	-	-	-	-	-	0,37	0,32	0,52	0,52	0,52	0,52	0,52	0,52

The times indicated for opening (O) and closing (C) of the valve corresponds to:

- 1/8, 32-50-63 mm operators, 3/2 pilots: [see page 49 (www.asco.com)]
- A: series 189 banjo - orifice size 1,2 mm, max. pilot pressure 10 bar
- C1: series 356 1/8 - Ø1,6 mm, max. pilot pressure 10 bar
- F1, Positioner²: max. pilot pressure 8 bar ⁽²⁾ (www.asco.com)

- 1/4, 90-125 mm operators, 3/2 pilots: [see page 51 (www.asco.com)]
- D: series 314 1/4 - Ø3,2 mm, max. pilot pressure 10 bar
- E: series 356 1/4 - Ø1,6 mm, max. pilot pressure 10 bar

series 298 / 398	Response time (in seconds) for NC valve series 298/398 (6 bar pilot air)																	
	80 mm operator				100 mm operator				150 mm operator				200 mm operator					
	Ø (DN)	pilots		pilots		pilots		pilots		pilots		pilots		pilots		pilots		
1/2 (15)	0,05	0,07	0,35	0,74	0,69	0,65	-	-	-	-	-	-	-	-	-	-	-	
3/4 (20)	-	-	-	-	-	-	0,08	0,12	0,13	0,48	0,48	0,92	0,77	1,59	0,98	-	-	
1 (25)	-	-	-	-	-	-	0,08	0,12	0,13	0,48	0,48	0,92	0,77	1,59	0,98	1,02	1,02	
1 1/4 (32)	-	-	-	-	-	-	0,08	0,12	0,13	0,48	0,48	0,92	0,77	1,59	0,98	1,02	1,02	
1 1/2 (40)	-	-	-	-	-	-	0,08	0,12	0,13	0,48	0,48	0,92	0,77	1,59	0,98	1,02	1,02	
2 (50)	-	-	-	-	-	-	0,08	0,12	0,13	0,48	0,48	0,92	0,77	1,59	0,98	1,02	1,02	

The times indicated for opening (O) and closing (C) of the valve corresponds to:

- 1/8, 80-100 mm operators, 3/2 pilots: [see page 71 (www.asco.com)] - 1/4, 150-200 mm, operators 3/2 pilots: [see page 73 (www.asco.com)]
- C1: series 356 1/8 - Ø1,6 mm, max. pilot pressure 10 bar
- (¹) Values for NC valves. For NO valves, interchange O and C values.
- F1, Positioner²: max. pilot pressure 8 bar ⁽²⁾ (www.asco.com)
- D: series 314 1/4 - Ø3,2 mm, max. pilot pressure 10 bar
- E: series 356 1/4 - Ø1,6 mm, max. pilot pressure 10 bar

⁽²⁾ See section: "Proportional Valves"

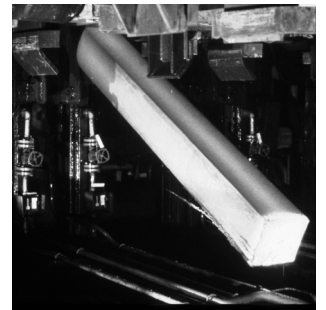
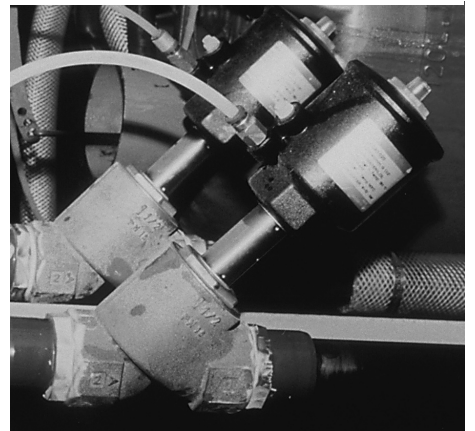
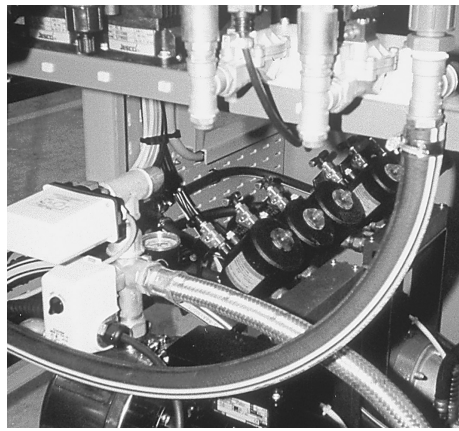
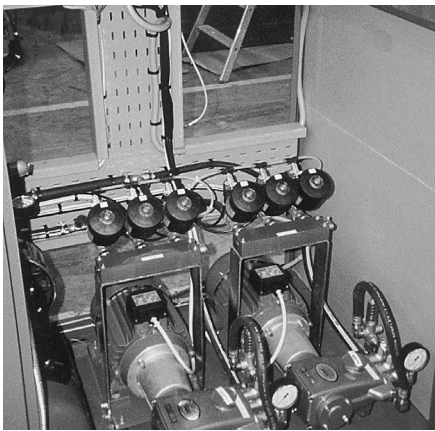
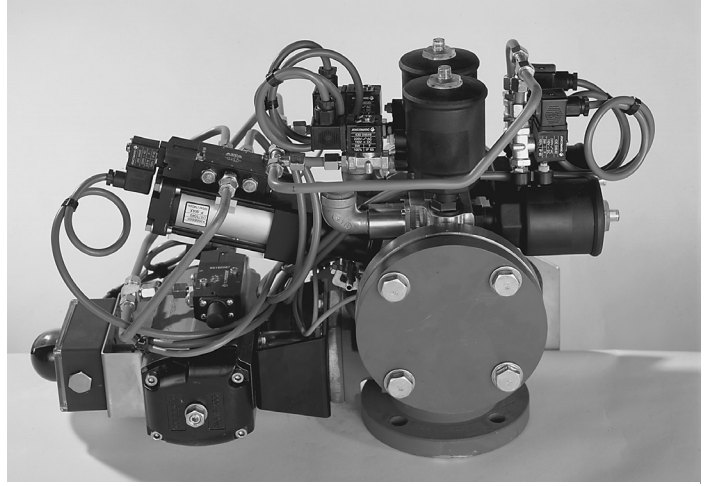
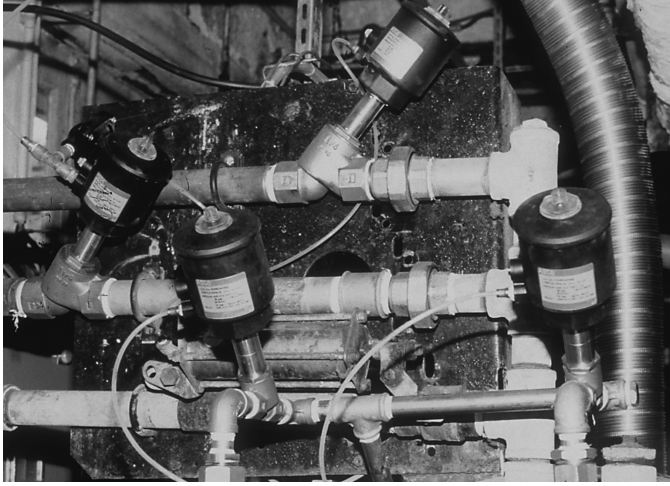

1	2
3	4 5
6	7 8

Series 290 - 390

- 1 Industrial laundry (steam circuit)
- 2 Special machinery
- 3 Special machinery with steam circuit
- 4 Food processing
- 5 Chemical product processing

Series 298 - 398

- 6 Autoclaves and industrial boilers
- 7 Tyre press or rubber parts applications (vulcanisation)
- 8 Iron and steel industry

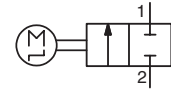

FEATURES

- High flow due to angled seat design
- Anti-waterhammer design (fluid entry under the disc)
- Actuator rotatable through 360°
- In option closing of the valve in case of power failure
- Fluid isolation between electrical actuator and valve body
- LED valves status display
- The valves satisfy Pressure Equipment Directive 2014/68/EU, article 3.3
- The motorised valves comply with the essential requirements of EMC Directive 2014/30/EU (EN-IEC 61000-6-2 and EN-IEC 61000-6-4) and Low Voltage Directive 2014/35/EU (EN-IEC 60730)
- Vacuum operation up to 10⁻² mbar
- The valves satisfy all relevant EC Directives and with the provisions of the Directive RoHS 2

GENERAL

Differential pressure See «SPECIFICATIONS» [1 bar =100 kPa]
Maximum allowable pressure 10 bar
Ambient temperature range -10°C to +50°C

Maximum viscosity -10°C to +40°C (for steam at 145°C)
Actuating time 600 cSt (mm²/s)
 < 1,3 s (opening) / < 1,3 s (closing)

fluids (*)	temperature range (TS)	seal materials (*)
air and gas groups 1 & 2	-10°C to +90°C	NBR (nitrile)
water, oil, liquids groups 1 & 2		
steam	up to +145°C	FPM (fluoroelastomer)

CONSTRUCTION

MATERIALS IN CONTACT WITH FLUID		
(*) Ensure that the compatibility of the fluids in contact with the materials is verified		
	NBR / PBT «K»	FPM / 316L «X»
Valve body	AISI 316L	AISI 316L
Stuffing box housing	PBT, GF reinforced	AISI 316L
Stem valve	AISI 316L	AISI 316L
Stuffing box packing	NBR	FPM
Wiper seal	NBR	FPM
Disc seal	NBR	FPM

OTHER MATERIALS

Top cover operator	Translucent polyamide (PA)
AC to DC housing (AC)	PA66, GF reinforced

ELECTRICAL CHARACTERISTICS

Connector	Spade plug (cable Ø 6-10 mm)
Connector specification	ISO 4400 / EN 175301-803, form A
Motor consumption	12 W in operation, 0 W hold Max. peak current: 0,7 A
Visualisation valve (switching)	LED
Electrical safety (adapter AC to DC)	IEC 335 (EN-IEC 60730), class 2
Electrical enclosure protection	IP65 (EN 60529)
Standard voltages	DC (=) : 24V ±10 %, max. ripple 5%
(EN-IEC 61131-2)	AC (~) : 110V to 250V / 50-60 Hz 24V to 48V ±10 % / 50-60 Hz

RECOMMENDATION FOR MAXIMUM DUTY CYCLE

FOR NBR / PBT «K» VERSION

Ambient temperature:	+20°C	9 cycles/min ⁽¹⁾
	+50°C (max.)	4 cycles/min ⁽¹⁾

RECOMMENDATION FOR MAXIMUM DUTY CYCLE

FOR FPM / 316L «X» VERSION

Ambient temperature:	+20°C	9 cycles/min ⁽¹⁾	fluid temp.:	+20°C
	+50°C (max.)	4 cycles/min ⁽¹⁾		+50°C
	+50°C (max.)	2 cycles/min ⁽¹⁾		+120°C
	+40°C (max.)	2 cycles/min ⁽¹⁾		+145°C

(*) Ensure that the compatibility of the fluids in contact with the materials is verified.

⁽¹⁾ For other cycles, contact us.

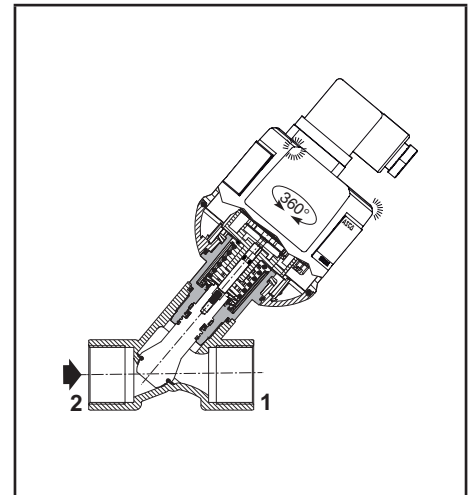

DC construction

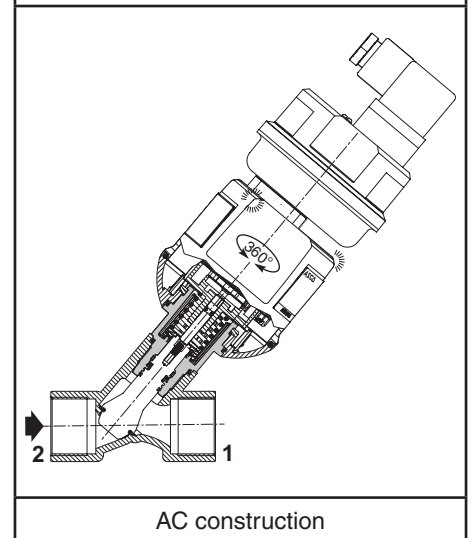

AC construction

OPERATING CONDITIONS RECOMMENDATION FOR MAXIMUM DUTY CYCLE

NBR / PBT «K» version

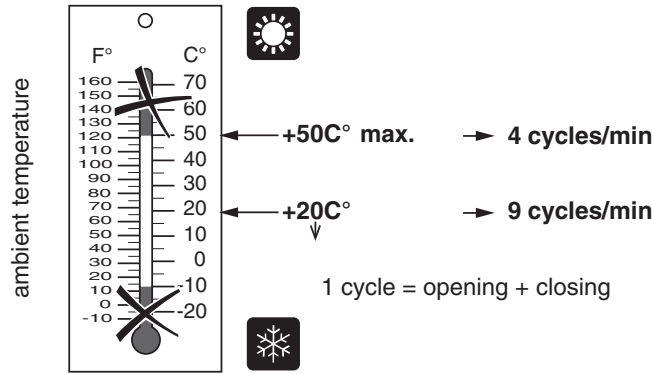

FPM / 316L «X» version

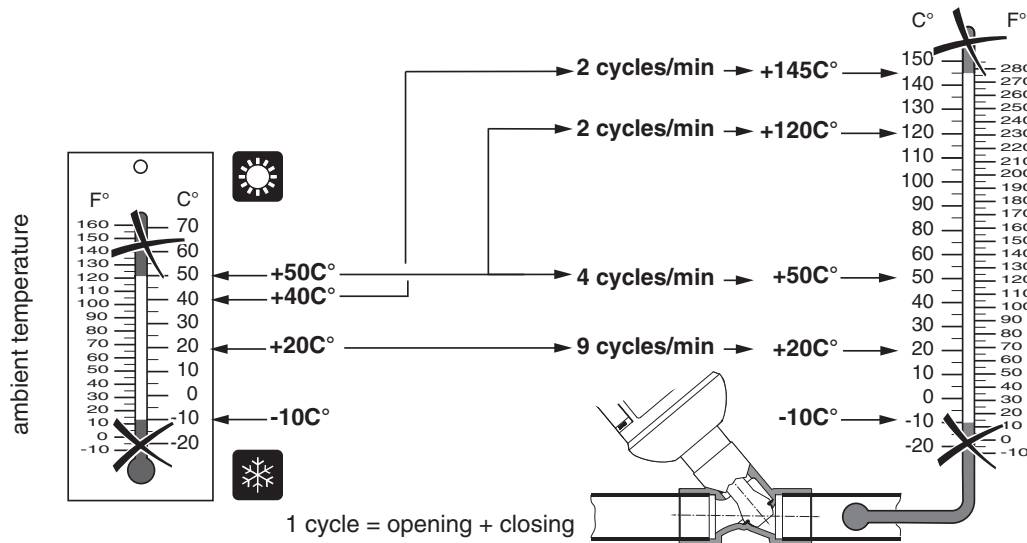

ACCESSORIES

AC to DC adapter: 110V to 250V/50-60 Hz
code: **P290CA430078001**
24V to 48V ±10 % / 50-60 Hz
code: **P290CA438907001**

OPTIONS

Fail closed (closing of the valve in case of power failure)

SPECIFICATIONS

piping (ISO 6708)		flow coefficient Kv		operating pressure differential (bar)			operator diameter (mm)	thread type	dimensions / type (1)	15-DIGIT PRODUCT CODE			
pipe size	DN	(m ³ /h)	(l/min)	min.	max.					basic code	voltage code		
					air, water, oil (*)	steam	24 V...48 V / 50-60 Hz	110 V...250 V / 50-60 Hz	24 V/DC				
Motorised valve, entry under the disc - NBR / PBT «K» version											UA	VW	V1
3/8	10	2,7	45	0	6	-	67	G*	1	E290C52V0KA00			
1/2	15	3,8	63	0	5	-	67	G*	1	E290C53V0KA00			
3/4	20	6	100	0	4	-	67	G*	1	E290C54V0KA00			
Motorised valve, entry under the disc - FPM / 316L «X» version											UA	VW	V1
3/8	10	2,7	45	0	6	4	67	G*	1	E290C52V0XA00			
1/2	15	3,8	63	0	5	4	67	G*	1	E290C53V0XA00			
3/4	20	6	100	0	4	4	67	G*	1	E290C54V0XA00			

(1) For dimensions, see drawing(s) for each construction type on the following page(s).

(*) Ensure that the compatibility of the fluids in contact with the materials is verified.

All leaflets are available on: www.asco.com

15-DIGIT PRODUCT CODE

E 290 C 5 4 V 0 K A00 V1

Pipe thread

E = ISO 228/1 & ISO 7/1 (combination thread)
8 = NPT (on request)

Product series
290

Revision letter
C = Initial release

Function
5 = Standard

DN
2 = DN 10
3 = DN 15
4 = DN 20

Motorised operator dia.
V = Ø 67 mm

Voltage

V1 = 24 V DC - class B
VW = 110 V...250 V 50/60 Hz - class B
UA = 24 V...48 V 50/60 Hz - class B

A00 = Standard

Options

EFC = Fail closed

Materials

K = AISI 316L body,
SS 316L stem,
PBT stuffing box & NBR
X = AISI 316L body,
SS 316L stem,
AISI 316L stuffing box & FPM

Port

0 = 2 way

INSTALLATION

- The valves can be mounted in any position without affecting operation
- Pipe connections (G*) have standard combination thread according to ISO 228/1 and ISO 7/1
- Other pipe connections are available on request
- Installation/maintenance instructions are included with each valve
- LED indicators for operating status display

status	valve OPEN	green
	valve CLOSED	orange
	valve moves to open	green flashing
	valve moves to close	orange flashing

OPERATING DIAGRAM

standard

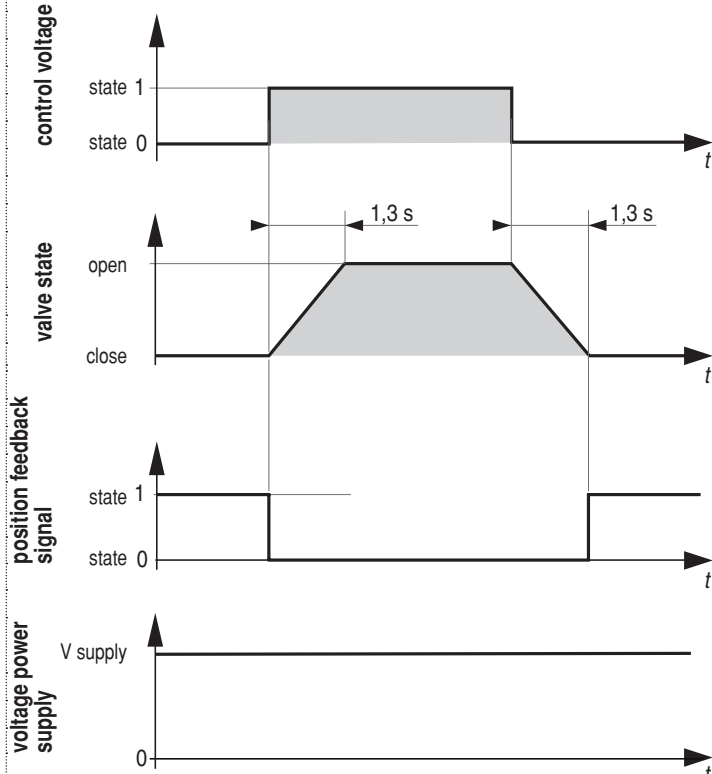

WIRING DC

24 V ±10 % / DC



1	24 V / DC
2	0 V
3	control
4	feedback signal

With PLC

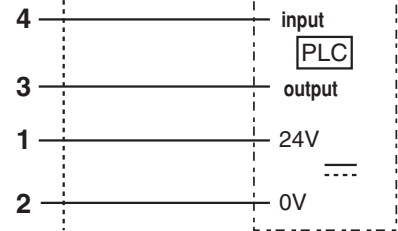
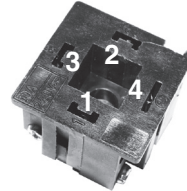

Without PLC

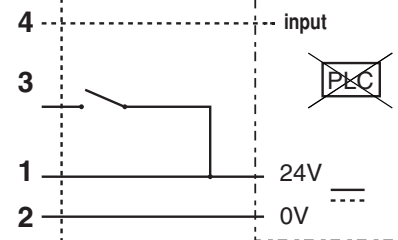
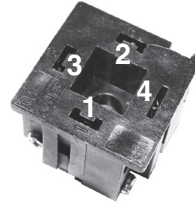

WIRING AC

24 V...48 V ±10 % / AC 50/60 Hz

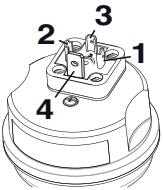

1	phase (Ph)
2	neutral (N)
3	control
4	feedback signal

With PLC

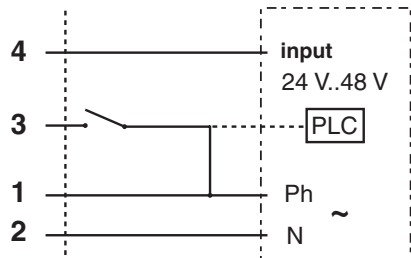
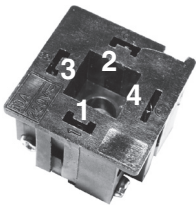

Without PLC

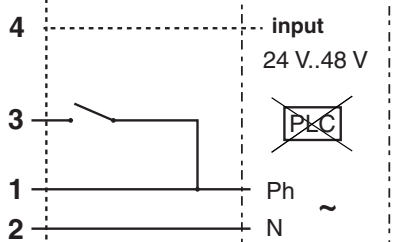

110 V...250 V / AC 50/60 Hz

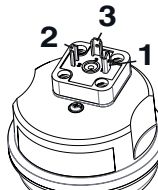

1	phase (Ph)
2	neutral (N)
3	control
-	-

With PLC

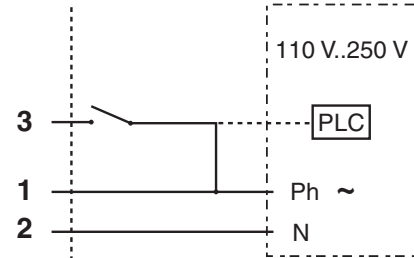
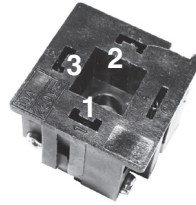

Without PLC

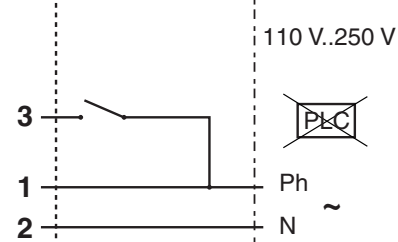
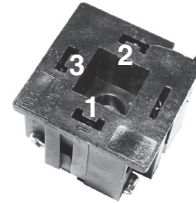

OPERATING DIAGRAM

fail closed

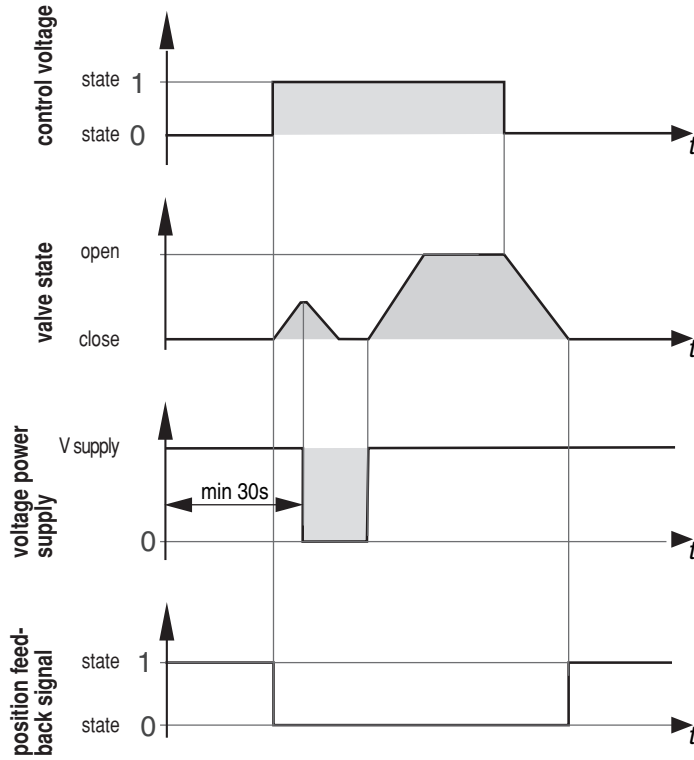

(*) Initialisation

WIRING DC

24 V $\pm 10\%$ / DC



1	24 V / DC
2	0 V
3	control
4	feedback signal

With PLC

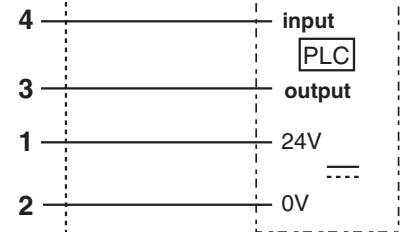
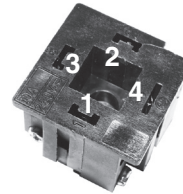

Without PLC

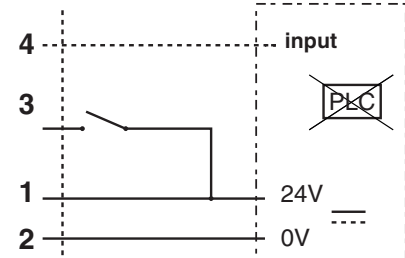
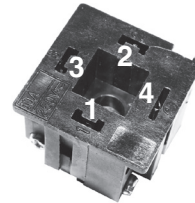

WIRING AC

24 V...48 V $\pm 10\%$ / AC 50/60 Hz

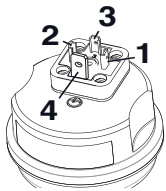

1	phase (Ph)
2	neutral (N)
3	control
4	feedback signal

With PLC

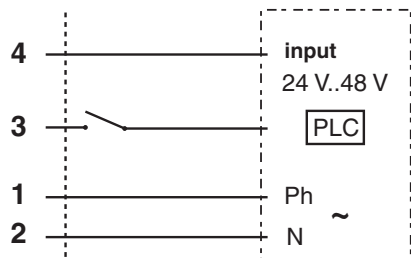
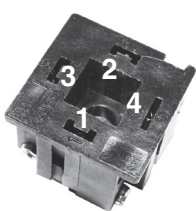

Without PLC

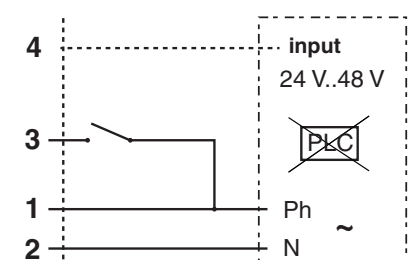
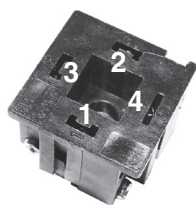

110 V...250 V / AC 50/60 Hz

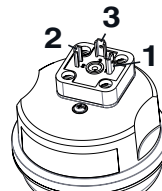

1	phase (Ph)
2	neutral (N)
3	control
-	-

With PLC

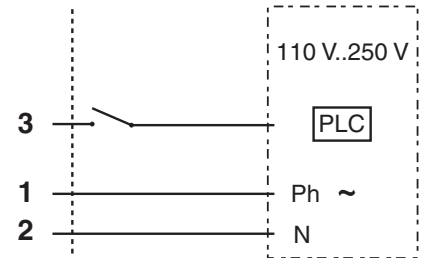
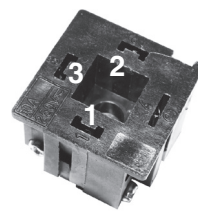

Without PLC

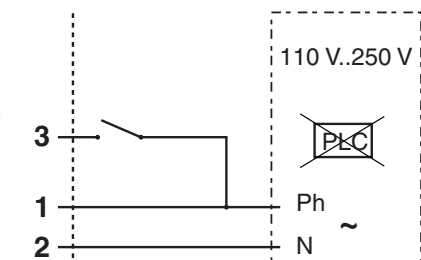
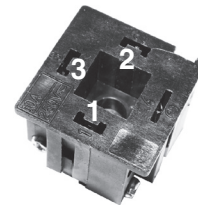

DIMENSIONS (mm), WEIGHT (kg)



TYPE 01

DC version
67 mm motorised operator
Fluid entry: under the disc at 2
ISO 4400 connector

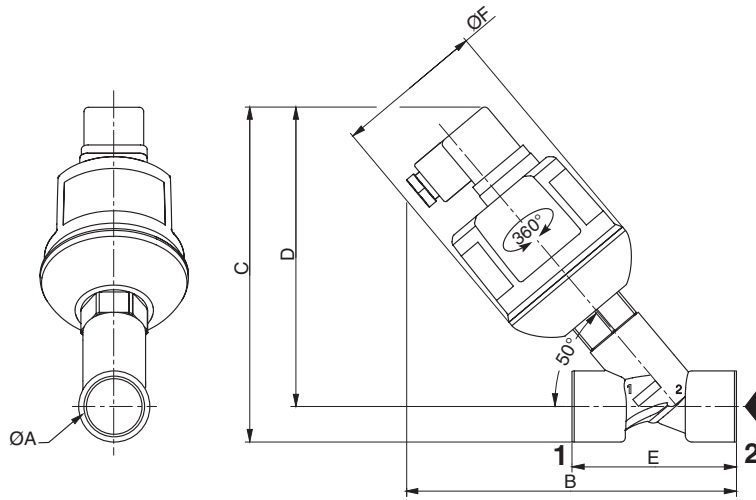

TYPE 02

AC version (accessories)
67 mm motorised operator with AC adapter
Fluid entry: under the disc at 2
ISO 4400 connector

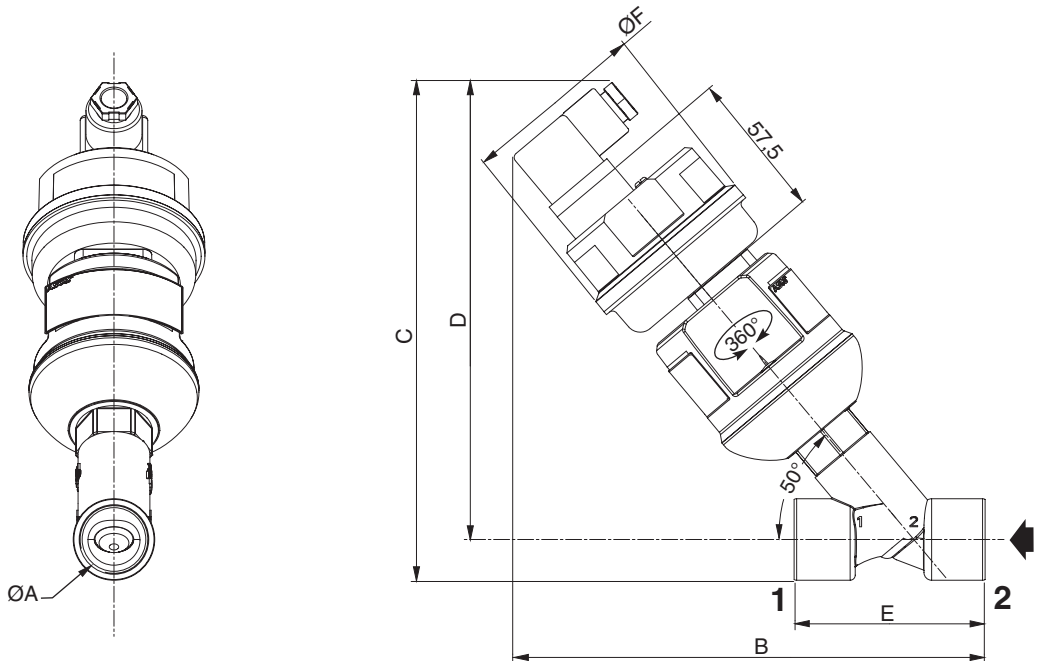

type	Ø A	B	C	D	E	Ø F	weight ⁽¹⁾	
							NBR / PBT «K»	FPM / 316L «X»
DC version								
01	3/8	135	141	129	55	67	0,40	0,45
	1/2	142	145	131	65	67	0,45	0,55
	3/4	150	152	136	75	67	0,55	0,65
AC version								
02	3/8	171	189	175	55	71	0,50	0,60
	1/2	178	191	177	65	71	0,55	0,65
	3/4	186	196	180	75	71	0,65	0,75

⁽¹⁾ Incl. connector.



VALVES

pressure operated
bronze or stainless steel body
threaded ports, 3/8 to 2 1/2

NC

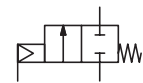

NO

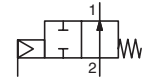

2/2
Series
E290

FEATURES

- High flow due to angled seat design
- Anti-waterhammer design (fluid entry under the disc)
- Vacuum operation up to 10² mbar
- Wide range of piston-type operators (32 - 50- 63 - 90 - 125 mm dia.) rotatable through 360°, for maximum performance at different minimum pilot pressures
- High performance, maintenance-free stuffing box
- The valves satisfy Pressure Equipment Directive 2014/68/EU, category 1 (DN > 25) or article 4.3 (DN ≤ 25)
- The valves in conformity with IEC 61508 Standard (2010 route 2_H version) certified with integrity levels: SIL 2 for HFT = 0

GENERAL

Differential pressure	See «SPECIFICATIONS» [1 bar =100 kPa]
Maximum allowable pressure	16 bar
Ambient temperature range	-10°C to +60°C
Maximum viscosity	600 cSt (mm ² /s)
Pilot fluid	Filtered air or water ⁽¹⁾
Max. pilot pressure	10 bar
Min. pilot pressure	See below and following page
Pilot fluid temperature	-10°C to +60°C
Response time	See page 7 (www.asco.com)



fluids (*)	temperature range	disc seal (*)
DN ≤ 50: air and gas groups 1 & 2 DN 65: air and gas group 2 all DN: water, oil, liquids groups 1 & 2 and steam	- 10°C to + 184°C	PTFE

MATERIALS IN CONTACT WITH FLUID

(*) Ensure that the compatibility of the fluids in contact with the materials is verified

	Bronze body	Stainless steel body
Valve body	Bronze	AISI 316L
Stuffing box housing	Brass	AISI 316L
Stem	Stainless steel	Stainless steel
Disc	Brass	Stainless steel
Stuffing box packing	PTFE chevrons	PTFE chevrons
Wiper seal	FPM	FPM
Disc seal	PTFE	PTFE
Valve body seal	PTFE	PTFE

OTHER MATERIALS

Operator	Glass fibre filled PA
Optical position indicator	PA 12, supplied standard on valves with 63, 90 and 125 mm operators

⁽¹⁾ For dia. 32, 50, 63, 90 and 125 mm operators: At service fluid temperatures inside the valve body above 100°C, it is prohibited to pilot the valve with water.

SPECIFICATIONS

piping (ISO 6708)		flow coefficient Kv		pilot pressure (bar)		operating pressure differential (bar)				operator diameter (mm)	catalogue number		
pipe size (G*)	DN	(m ³ /h)	(l/min)	min.	max.	min.	max.				bronze	stainless steel	
							air, inert gas, aggressive fluids (*)	water, oil, liquids, aggressive liquids (*)	steam (*) (≤184°C)				
NC - Normally closed, entry under the disc ⁽¹⁾													
3/8	10	2,8	47	4	10	0	16	16	10	32	-	E290A791	
		4,1	68	4	10	0	12	12	10	32	-	E290A792	
1/2	15	4,9	82	4	10	0	16	16	10	50	E290A384	E290A393	
				2,5	10	0	16	16	10	63	E290B002	E290B045	
3/4	20	6,5	108	4	10	0	6	6	6	32	-	E290A793	
				10	10	0	10	10	10	50	E290A385	E290A394	
		9,4	157	4	10	0	16	16	10	63	E290B005	E290B048	
				2,5	10	0	12	12	10	63	E290B004	E290B047	
1	25	12,8	213	4	10	0	6	6	6	50	E290A386	E290A395	
				10	10	0	10	10	10	63	E290B010	E290B053	
		16,5	275	4	10	0	16	16	10	90	E290B011	E290B054	
				2,5	10	0	6	6	6	63	E290B008	E290B051	
1 1/4	32	27	450	4	10	0	12	12	10	90	E290A016	E290A059	
				2,5	10	0	3	3	3	63	E290A017	E290A060	
		29	483	4	10	0	7	7	7	63	E290A014	E290A057	
				2,5	10	0	16	16	10	90	E290A015	E290A058	
		2,5	10	0	4	10	0	16	16	10	125	E290A642	E290A646
					2,5	10	0	16	16	10	125	E290A641	E290A645

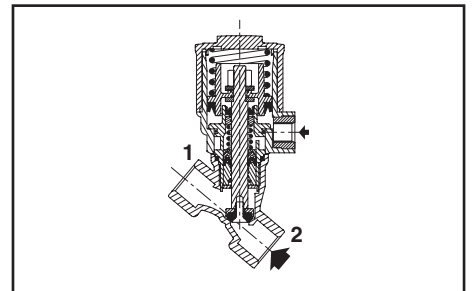

NC function, entry under the disc, 32 and 50 mm operators

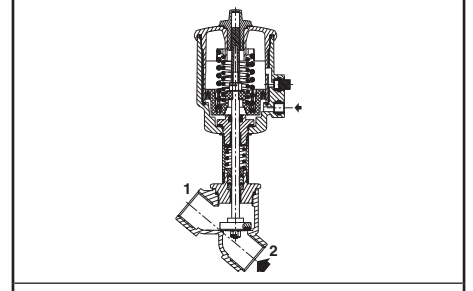

NC function, entry under the disc, 63, 90 and 125 mm operators

SPECIFICATIONS

piping (ISO 6708)		flow coefficient Kv		pilot pressure (bar)		operating pressure differential (bar)			operator diameter (mm)	catalogue number				
pipe size (G*)	DN	(m³/h)	(l/min)	min.	max.	min.	max.			bronze	stainless steel			
							air, inert gas, aggressive fluids (*)	water, oil, liquids, aggressive liquids (*)	steam (*) (≤184°C)					
NC - Normally closed, entry under the disc ⁽¹⁾														
1 1/2	40	45	750	4	10	0	4	4	4	63	E290A020	E290A063		
				2,5	10	0	8	8	8	90	E290A021	E290A064		
		48	800	4	10	0	4	4	4	90	E290A019	E290A062		
				2,5	10	0	16	16	10	125	E290A482	E290A495		
2	50	59	983	4	10	0	2,5	2,5	2,5	63	E290A024	E290A067		
				2,5	10	0	6	6	6	90	E290A025	E290A068		
		66	1100	4	10	0	2,5	2,5	2,5	90	E290A023	E290A066		
				2,5	10	0	10	10	10	125	E290A485	E290A498		
		2 1/2	65	94	1567	4	10	0	5	5	5	125	E290A484	-
				111	1850	4	10	0	2	2	2	90	E290A487	E290A500
				4	10	0	6	6	6	125	E290A488	E290A501		
NO - Normally open, entry under the disc														
3/8	10	2,8	47	IX (*)	10	0	16	16	10	32	-	E290A794		
1/2	15	4,1	68	IX (*)	10	0	16	16	10	32	-	E290A795		
		4,9	82	I (*)	10	0	16	16	10	50	E290A387	E290A396		
II (*)	10			0	16	16	10	63	E290B026	E290B069				
3/4	20	6,5	108	IX (*)	10	0	16	16	10	32	-	E290A796		
		9,4	157	I (*)	10	0	16	16	10	50	E290A388	E290A397		
II (*)	10			0	16	16	10	63	E290B027	E290B070				
1	25	12,8	213	I (*)	10	0	16	16	10	50	E290A389	-		
		16,5	275	II (*)	10	0	16	16	10	63	E290B028	E290B071		
III (*)	10			0	16	16	10	90	E290B029	E290B072				
1 1/4	32	27	450	II (*)	10	0	16	16	10	63	E290A030	E290A073		
		29	483	III (*)	10	0	16	16	10	90	E290A031	E290A074		
IV (*)	10			0	16	16	10	125	E290A643	E290A647				
1 1/2	40	45	750	II (*)	10	0	11	11	10	63	E290A032	E290A075		
		48	800	III (*)	10	0	16	16	10	90	E290A033	E290A076		
IV (*)	10			0	16	16	10	125	E290A489	E290A502				
2	50	59	983	II (*)	10	0	7	7	7	63	E290A034	E290A077		
		66	1100	III (*)	10	0	13	13	10	90	E290A035	E290A078		
IV (*)	10			0	16	16	10	125	E290A490	E290A503				
2 1/2	65	94	1567	III (*)	10	0	7	7	7	90	E290A491	E290A504		
		111	1850	IV (*)	10	0	16	16	10	125	E290A492	E290A505		
NC - Normally closed, entry above the disc (version recommended for rapid-cycling steam applications)														
3/8	10	2,8	47	X (*)	10	0	10	-	10	32	-	E290A797		
1/2	15	4,1	68	X (*)	10	0	10	-	10	32	-	E290A798		
		4,9	82	V (*)	10	0	10	-	10	50	E290A390	E290A399		
VI (*)	10			0	10	-	10	63	E290B036	E290B079				
3/4	20	6,5	108	X (*)	10	0	10	-	10	32	-	E290A799		
		9,4	157	V (*)	10	0	10	-	10	50	E290A391	E290A400		
VI (*)	10			0	10	-	10	63	E290B037	E290B080				
1	25	12,8	213	V (*)	10	0	10	-	10	50	E290A392	E290A401		
		16,5	275	VI (*)	10	0	10	-	10	63	E290B038	E290B081		
VI (*)	10			0	10	-	10	63	E290A039	E290A082				
1 1/4	32	27	450	VII (*)	10	0	10	-	10	90	E290A136	E290A137		
1 1/2	40	45	750	VI (*)	10	0	10	-	10	63	E290A040	E290A083		
				VII (*)	10	0	10	-	10	90	E290A041	E290A084		
2	50	59	983	VI (*)	10	0	9	-	9	63	E290A042	E290A085		
				VII (*)	10	0	10	-	10	90	E290A043	E290A086		
2 1/2	65	94	1567	VII (*)	10	0	10	-	10	90	E290A623	E290A625		
		111	1850	VIII (*)	10	0	10	-	10	125	E290A624	-		

 (*) Minimum pilot pressure varies with differential pressure, see page: 7 (www.asco.com)

(1) Calculation of the minimum pilot pressure at a ΔP of max. 10 bar with allowable backpressure (backpressure not recommended with liquids as waterhammer may occur).

 - 32 and 50 mm operators, 4 bar minimum pilot pressure version: add 2 bar to the minimum pilot pressure of chart V or X [see page: 7 (www.asco.com)]

 - 63, 90 and 125 mm operators, 4 bar minimum pilot pressure version: add 1,5 bar to the minimum pilot pressure of chart VI, VII or VIII [see page: 7 (www.asco.com)]

OPTIONS AND ACCESSORIES [see pages: 37 (www.asco.com) / 43 (www.asco.com)]

- Signaling box or compact signaling unit
- Stroke limiter for opening
- Manual safety device
- Optical position indicator on 32-50 mm operators, NC function
- Adapter plate for NAMUR pad mounting pilot (63-90-125 mm operators only)
- Oxygen service (except DN 65), pressure limited to 15 bar, temperature limited to + 60°C
- Vacuum applications up to 1,33 10⁻³ mbar
- NET-INOX passivation treatment on stainless steel body valve
- ATEX 2014/34/EU versions for potentially explosive atmospheres (www.asco.com)
- Other pipe connections are available on request

INSTALLATION

- The valves can be mounted in any position without affecting operation
- Compatible with ASTM 1, 2 and 3 oils
- Check temperature range of valve body and solenoid pilot valves for suitability. For probability of failure, contact us
- Pipe connections (G*) have standard combination thread according to ISO 228/1 and ISO 7/1
- Installation/maintenance instructions are included with each valve

SPARE PARTS KITS

DN	spare parts kit no.	
	Ø 32 mm	Ø 50-63-90-125 mm
10	C140100	-
15	C140101	C131204 ⁽¹⁾
20	C140102	C131205 ⁽¹⁾
25	-	C131206 ⁽¹⁾
32	-	C131207 ⁽¹⁾
40	-	C131208 ⁽¹⁾
50	-	C131209 ⁽¹⁾
65	-	C131622 ⁽¹⁾

⁽¹⁾ Standard suffix VM also applies to kits. [see page: 37 (www.asco.com)].
 - Not available

ORDERING EXAMPLES:

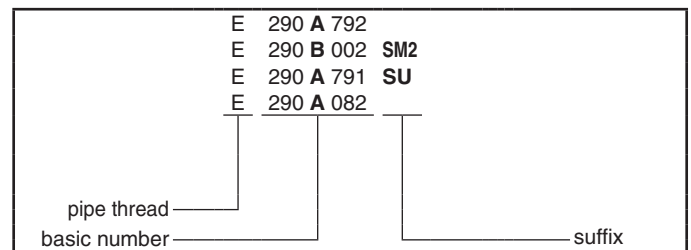

ORDERING EXAMPLES KITS:

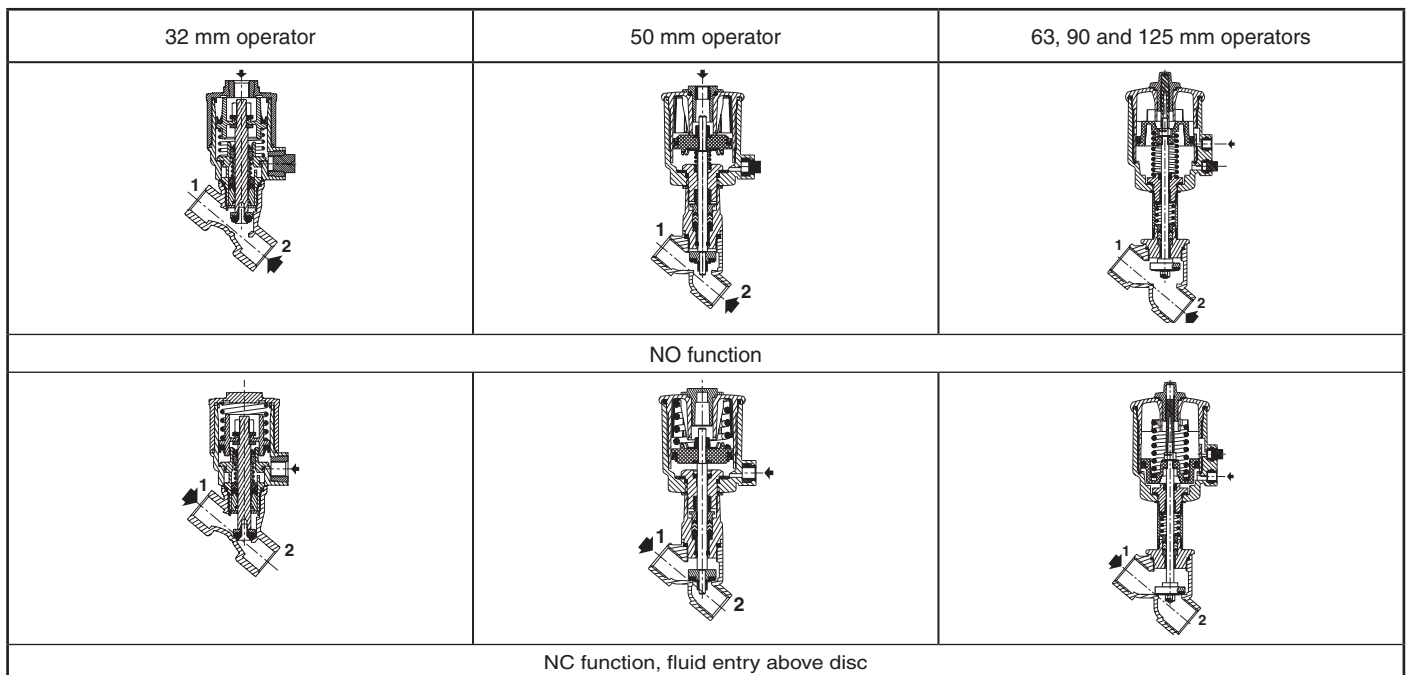
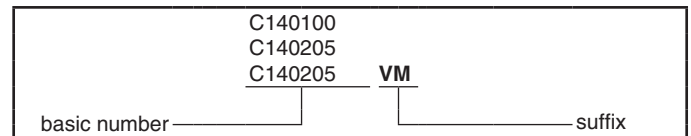

DIMENSIONS (mm), WEIGHT (kg)

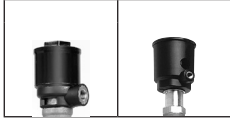

TYPE 01-02
32 and 50 mm operators
Fluid entry:
under the disc at 2
above the disc at 1

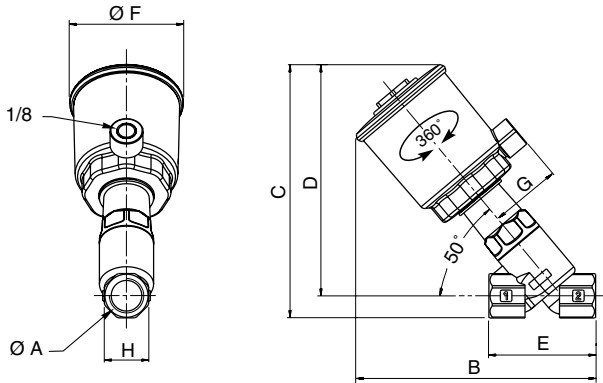

type	operator diameter	ØA	B	C	D	E	ØF	G	ØH	weight ⁽¹⁾
01	32 mm	3/8	92	93	81,5	55	43,5	27	23,5	0,35
		1/2	99	97	83,5	65	43,5	27	28	0,4
		3/4	107	104,5	88	75	43,5	27	30	0,45
02	50 mm	1/2	142	154,5	141	65	69	43	27	0,9
		3/4	150,5	159	143	75	69	43	32	1
		1	155	165	145	90	69	43	41	1,4

⁽¹⁾ Weight of valve without pilot.
Solenoid pilot valves, see page: [49 \(www.asco.com\)](http://www.asco.com) [32 and 50 mm operators].

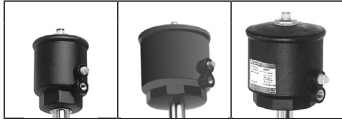

TYPE 03-04-05
63, 90 and 125 mm operators
Fluid entry:
under the disc at 2
above the disc at 1

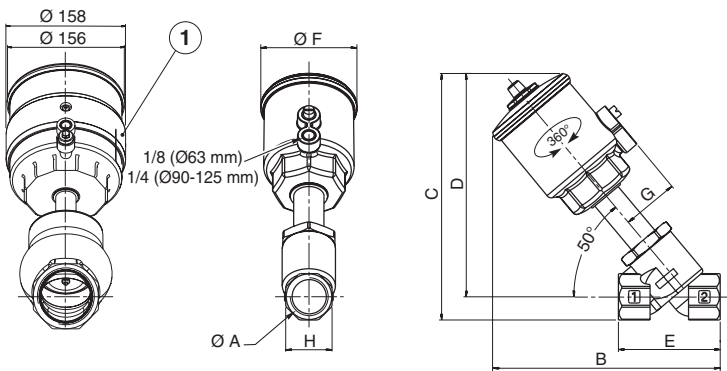

① Operator dia. 125 mm, NO function

type	operator diameter	ØA	B	C	D	E	ØF	G	ØH	weight ⁽¹⁾
03	63 mm	1/2	170	182	169	65	85	50,5	27	1,2
		3/4	175	185	170	75	85	50,5	32	1,3
		1	179	192	172	90	85	50,5	41	1,7
		1 1/4	217	229	204	110	85	50,5	50	2,1
		1 1/2	224	245	215	120	85	50,5	60	2,9
		2	249	259	224	150	85	50,5	70	3,7
04	90 mm	1	197	209	189	90	118	67	41	2,3
		1 1/4	236	246	221	110	118	67	50	2,7
		1 1/2	243	262	232	120	118	67	60	3,5
		2	267	276	241	150	118	67	70	4,3
05	125 mm	2 1/2	299	300	257	190	118	67	86	6,3
		1 1/4	284	298	273	110	156	86	50	5,2
		1 1/2	291	313,5	283,5	120	156	86	60	6
		2	315	328	293	150	156	86	70	6,8
		2 1/2	347	352	308	190	156	86	86	8,9

⁽¹⁾ Weight of valve without pilot. Add 0,2 for dia. 125 mm operator NO.
Solenoid pilot valves, see pages: [49 \(www.asco.com\)](http://www.asco.com) [63 mm operator] / [51 \(www.asco.com\)](http://www.asco.com) [90 and 125 mm operators]

All leaflets are available on: www.asco.com



VALVES

pressure operated
Food contact version
stainless steel body, threaded ports, 3/8 to 2 1/2

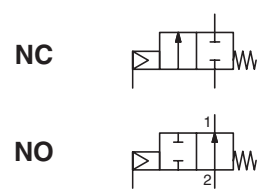

2/2
Series
E290

FEATURES

- Valve in conformity with Regulation (EC) 1935-2004, the material of the wetted parts are listed in the chart of the Annex I of Regulation (EC) 1935/2004
- All the material of the wetted parts are conform with FDA CFR21
- High flow due to angled seat design
- Anti-waterhammer design (fluid entry under the disc)
- Vacuum operation up to 10^{-2} mbar
- Wide range of piston-type operators (32 - 50- 63 - 90 - 125 mm dia.) rotatable through 360°, for maximum performance at different minimum pilot pressures
- High performance, maintenance-free stuffing box
- The valves satisfy Pressure Equipment Directive 2014/68/EU, category 1 (DN > 25) or article 4.3 (DN ≤ 25)
- The valves in conformity with IEC 61508 Standard (2010 route 2_H version) certified with integrity levels: SIL 2 for HFT = 0
- Valve in conformity with the provisions of the directive RoHS 2 (EU 2001/65)

GENERAL

Differential pressure	See «SPECIFICATIONS» [1 bar =100 kPa]
Maximum allowable pressure	16 bar
Ambient temperature range	-10°C to +60°C
Maximum viscosity	600 cSt (mm ² /s)
Pilot fluid	Filtered air or water ⁽¹⁾
Max. pilot pressure	10 bar
Min. pilot pressure	See below and following page
Pilot fluid temperature	-10°C to +60°C
Response time	See page 7 (www.asco.com)

fluids (*)	temperature range	disc seal (*)
DN ≤ 50: air and gas groups 1 & 2 DN 65: air and gas group 2 all DN: water, oil, liquids groups 1 & 2 and steam	- 10°C to + 184°C	PTFE

MATERIALS IN CONTACT WITH FLUID

(*) Ensure that the compatibility of the fluids in contact with the materials is verified

	Stainless steel body	All AISI 316L
Valve body	AISI 316L	AISI 316L ⁽²⁾
Stuffing box housing	AISI 316L	AISI 316L ⁽²⁾
Stem	Stainless steel	AISI 316L
Disc	Stainless steel	AISI 316L
Stuffing box packing	PTFE chevrons	PTFE chevrons
Wiper seal	PTFE	PTFE
Disc seal	PTFE	PTFE
Valve body seal	PTFE	PTFE

OTHER MATERIALS

Operator	Glass fibre filled PA
Optical position indicator	PA 12, supplied standard on valves with 63, 90 and 125 mm operators

⁽¹⁾ For dia. 32, 50, 63, 90 and 125 mm operators: At service fluid temperatures inside the valve body above 100°C, it is prohibited to pilot the valve with water.

⁽²⁾ NET-INOX passivation treatment included.

SPECIFICATIONS

piping (ISO 6708)		flow coefficient Kv		pilot pressure (bar)		operating pressure differential (bar)			operator diameter	catalogue number		
pipe size (G ⁺)	DN	(m ³ /h) (l/min)		(bar)		min.	max.			(mm)	stainless steel	all AISI 316L
		air, inert gas, aggressive fluids (*)	water, oil, liquids, aggressive liquids (*)	steam (*) (≤184°C)								
NC - Normally closed, entry under the disc ⁽¹⁾												
3/8	10	2,8	47	4	10	0	16	16	10	32	E290A791FB	E290A845FB
		4,1	68	4	10	0	12	12	10	32	E290A792FB	E290A846FB
1/2	15	4,9	82	4	10	0	16	16	10	50	E290A393FB	E290A402FB
				2,5	10	0	16	16	10	63	E290B045FB	E290B088FB
		6,5	108	4	10	0	6	6	6	32	E290A793FB	E290A847FB
3/4	20	9,4	157	4	10	0	10	10	10	50	E290A394FB	E290A403FB
							16	16	10	63	E290B048FB	E290B091FB
		12,8	213	4	10	0	6	6	6	50	E290A395FB	E290A404FB
1	25	16,5	275	4	10	0	10	10	10	63	E290B053FB	E290B096FB
							16	16	10	90	E290B054FB	E290B097FB
		27	450	4	10	0	6	6	6	63	E290A059FB	E290A102FB
1 1/4	32	29	483	4	10	0	12	12	10	90	E290A060FB	E290A103FB
							16	16	10	125	E290A646FB	E290A650FB
		2,5	10	0	16	16	10	125	E290A645FB	E290A649FB		

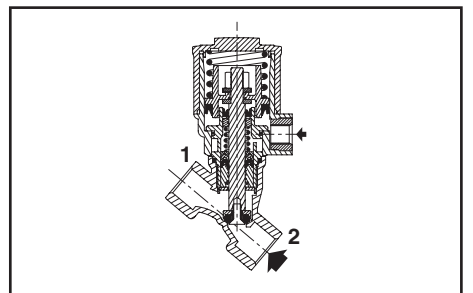

NC function, entry under the disc, 32 and 50 mm operators

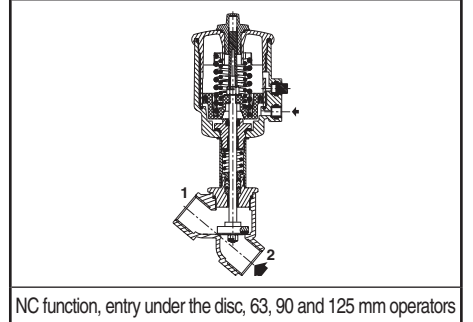

NC function, entry under the disc, 63, 90 and 125 mm operators

SPECIFICATIONS

piping (ISO 6708)		flow coefficient Kv		pilot pressure (bar)		operating pressure differential (bar)			operator diameter	catalogue number		
pipe size (G*)	DN	(m ³ /h) (l/min)		min.	max.	min.	max.			(mm)	stainless steel	all AISI 316L
							air, inert gas, aggressive fluids (*)	water, oil, liquids, aggressive liquids (*)	steam (*) (≤184°C)			
NC - Normally closed, entry under the disc ⁽¹⁾												
1 1/2	40	45	750	4	10	0	4	4	4	63	E290A063FB	E290A106FB
		48	800	4	10	0	8	8	8	90	E290A064FB	E290A107FB
				2,5	10	0	16	16	10	125	E290A495FB	E290A508FB
2	50	59	983	4	10	0	10	10	10	125	E290A494FB	E290A507FB
		66	1100	2,5	10	0	2,5	2,5	2,5	63	E290A067FB	E290A110FB
				6	10	0	6	6	6	90	E290A068FB	E290A111FB
2 1/2	65	94	1567	4	10	0	10	10	10	125	E290A498FB	E290A511FB
		111	1850	4	10	0	2	2	2	90	E290A500FB	E290A513FB
				6	10	0	6	6	6	125	E290A501FB	E290A514FB
NO - Normally open, entry under the disc												
3/8	10	2,8	47	IX (*)	10	0	16	16	10	32	E290A794FB	E290A848FB
1/2	15	4,1	68	IX (*)	10	0	16	16	10	32	E290A795FB	E290A849FB
		4,9	82	I (*)	10	0	16	16	10	50	E290A396FB	E290A405FB
3/4	20	6,5	108	IX (*)	10	0	16	16	10	32	E290A796FB	E290A850FB
		9,4	157	I (*)	10	0	16	16	10	50	E290A397FB	E290A406FB
				II (*)	10	0	16	16	10	63	E290B070FB	E290B113FB
1	25	16,5	275	II (*)	10	0	16	16	10	63	E290B071FB	E290B114FB
				III (*)	10	0	16	16	10	90	E290B072FB	E290B115FB
				II (*)	10	0	16	16	10	63	E290A073FB	E290A116FB
1 1/4	32	27	450	III (*)	10	0	16	16	10	90	E290A074FB	E290A117FB
		29	483	IV (*)	10	0	16	16	10	125	E290A647FB	E290A651FB
1 1/2	40	45	750	II (*)	10	0	11	11	10	63	E290A075FB	E290A118FB
		48	800	III (*)	10	0	16	16	10	90	E290A076FB	E290A119FB
2	50	59	983	IV (*)	10	0	16	16	10	125	E290A502FB	E290A515FB
		66	1100	II (*)	10	0	7	7	7	63	E290A077FB	E290A120FB
				III (*)	10	0	13	13	10	90	E290A078FB	E290A121FB
2 1/2	65	94	1567	IV (*)	10	0	16	16	10	125	E290A503FB	E290A516FB
		111	1850	III (*)	10	0	7	7	7	90	E290A504FB	E290A517FB
				IV (*)	10	0	16	16	10	125	E290A505FB	E290A518FB
NC - Normally closed, entry above the disc (version recommended for rapid-cycling steam applications)												
3/8	10	2,8	47	X (*)	10	0	10	-	10	32	E290A797FB	-
1/2	15	4,1	68	X (*)	10	0	10	-	10	32	E290A798FB	-
		4,9	82	V (*)	10	0	10	-	10	50	E290A399FB	-
3/4	20	6,5	108	VI (*)	10	0	10	-	10	63	E290B079FB	-
		9,4	157	X (*)	10	0	10	-	10	32	E290A799FB	-
				V (*)	10	0	10	-	10	50	E290A400FB	-
1	25	16,5	275	VI (*)	10	0	10	-	10	63	E290B080FB	-
				V (*)	10	0	10	-	10	50	E290A401FB	-
				VI (*)	10	0	10	-	10	63	E290B081FB	-
1 1/4	32	27	450	VII (*)	10	0	10	-	10	63	E290A082FB	-
		29	483	VI (*)	10	0	10	-	10	90	E290A137FB	-
1 1/2	40	45	750	VI (*)	10	0	10	-	10	63	E290A083FB	-
		48	800	VII (*)	10	0	10	-	10	90	E290A084FB	-
2	50	59	983	VI (*)	10	0	9	-	9	63	E290A085FB	-
		66	1100	VII (*)	10	0	10	-	10	90	E290A086FB	-
2 1/2	65	94	1567	VII (*)	10	0	10	-	10	90	E290A625FB	-

 (*) Minimum pilot pressure varies with differential pressure, see page: 7 (www.asco.com)

(1) Calculation of the minimum pilot pressure at a ΔP of max. 10 bar with allowable backpressure (backpressure not recommended with liquids as waterhammer may occur).

 - 32 and 50 mm operators, 4 bar minimum pilot pressure version: add 2 bar to the minimum pilot pressure of chart V or X [see page: 7 (www.asco.com)]

 - 63, 90 and 125 mm operators, 4 bar minimum pilot pressure version: add 1,5 bar to the minimum pilot pressure of chart VI, VII or VIII [see page: 7 (www.asco.com)]

OPTIONS AND ACCESSORIES [see pages: 37 (www.asco.com) / 43 (www.asco.com)]

- Signaling box or compact signaling unit
- Stroke limiter for opening
- Manual safety device
- Optical position indicator on 32-50 mm operators, NC function
- Adapter plate for NAMUR pad mounting pilot (63-90-125 mm operators only)
- NET-INOX passivation treatment on stainless steel body valve
- ATEX 2014/34/EU versions for potentially explosive atmospheres (www.asco.com)
- Other pipe connections are available on request

INSTALLATION

- The valves can be mounted in any position without affecting operation
- Compatible with ASTM 1, 2 and 3 oils
- Check temperature range of valve body and solenoid pilot valves for suitability. For probability of failure, contact us
- Pipe connections (G*) have standard combination thread according to ISO 228/1 and ISO 7/1
- Installation/maintenance instructions are included with each valve

SPARE PARTS KITS

DN	spare parts kit no.	
	Ø 32 mm	Ø 50-63-90-125 mm
10	C140100FB	-
15	C140101FB	C131204FB
20	C140102FB	C131205FB
25	-	C131206FB
32	-	C131207FB
40	-	C131208FB
50	-	C131209FB
65	-	C131622FB

- Not available

ORDERING EXAMPLES:

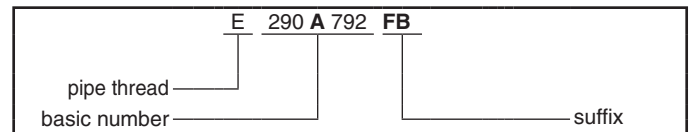

ORDERING EXAMPLES KITS:

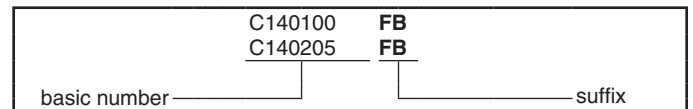

32 mm operator	50 mm operator	63, 90 and 125 mm operators
NO function		
NC function, fluid entry above disc		

DIMENSIONS (mm), WEIGHT (kg)



TYPE 01-02
32 and 50 mm operators
Fluid entry:
under the disc at 2
above the disc at 1

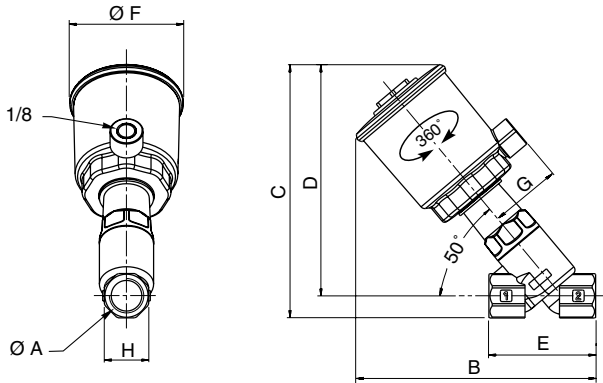

type	operator diameter	ØA	B	C	D	E	ØF	G	ØH	weight ⁽¹⁾
01	32 mm	3/8	92	93	81,5	55	43,5	27	23,5	0,35
		1/2	99	97	83,5	65	43,5	27	28	0,4
		3/4	107	104,5	88	75	43,5	27	30	0,45
02	50 mm	1/2	142	154,5	141	65	69	43	27	0,9
		3/4	150,5	159	143	75	69	43	32	1
		1	155	165	145	90	69	43	41	1,4

⁽¹⁾ Weight of valve without pilot.
Solenoid pilot valves, see page: 49 (www.asco.com) [32 and 50 mm operators].

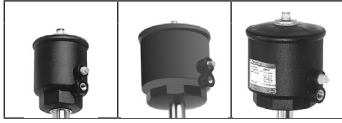

TYPE 03-04-05
63, 90 and 125 mm operators
Fluid entry:
under the disc at 2
above the disc at 1

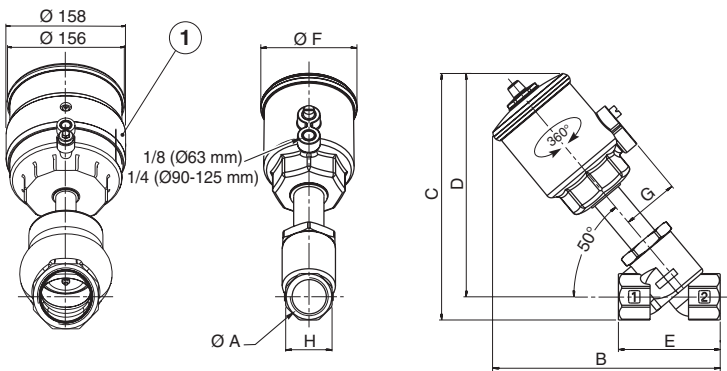

① Operator dia. 125 mm, NO function

type	operator diameter	ØA	B	C	D	E	ØF	G	ØH	weight ⁽¹⁾
03	63 mm	1/2	170	182	169	65	85	50,5	27	1,2
		3/4	175	185	170	75	85	50,5	32	1,3
		1	179	192	172	90	85	50,5	41	1,7
		1 1/4	217	229	204	110	85	50,5	50	2,1
		1 1/2	224	245	215	120	85	50,5	60	2,9
		2	249	259	224	150	85	50,5	70	3,7
04	90 mm	1	197	209	189	90	118	67	41	2,3
		1 1/4	236	246	221	110	118	67	50	2,7
		1 1/2	243	262	232	120	118	67	60	3,5
		2	267	276	241	150	118	67	70	4,3
05	125 mm	2 1/2	299	300	257	190	118	67	86	6,3
		1 1/4	284	298	273	110	156	86	50	5,2
		1 1/2	291	313,5	283,5	120	156	86	60	6
		2	315	328	293	150	156	86	70	6,8
		2 1/2	347	352	308	190	156	86	86	8,9

⁽¹⁾ Weight of valve without pilot. Add 0,2 for dia. 125 mm operator NO.
Solenoid pilot valves, see pages: 49 (www.asco.com) [63 mm operator] / 51 (www.asco.com) [90 and 125 mm operators]

All leaflets are available on: www.asco.com



MINI-VALVES

pressure operated
stainless steel body
threaded ports, G 1/2 to 1

NC

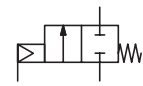

NO

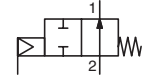

2/2
Series
U290

FEATURES

- High flow due to angled seat design
- Anti-waterhammer design (fluid entry under the disc)
- External threads to ISO 228/1 for industrial applications
- Vacuum operation up to 10^{-2} mbar
- Piston-type operators 32 mm dia. rotatable through 360°
- High performance, maintenance-free stuffing box
- The valves satisfy Pressure Equipment Directive 2014/68/EU, article 4.3
- The valves in conformity with IEC 61508 Standard (2010 route 2_H version) certified with integrity levels: SIL 2 for HFT = 0

GENERAL

Differential pressure	See «SPECIFICATIONS» [1 bar =100 kPa]
Maximum allowable pressure	16 bar
Ambient temperature range	-10°C to +60°C
Maximum viscosity	600 cSt (mm ² /s)
Pilot fluid	Filtered air or water ⁽¹⁾
Max. pilot pressure	10 bar
Min. pilot pressure	See below
Pilot fluid temperature	-10°C to +60°C
Response time	See page 7 (www.asco.com)

fluids (*)	temperature range	disc seal (*)
air and gas groups 1 & 2 water, oil, liquids groups 1 & 2 and steam	- 10°C to + 184°C	PTFE

MATERIALS IN CONTACT WITH FLUID

(*) Ensure that the compatibility of the fluids in contact with the materials is verified

Valve body	AISI 316L
Stuffing box housing	AISI 316L
Stem	Stainless steel
Disc	Stainless steel
Stuffing box packing	PTFE chevrons
Wiper seal	FPM
Disc seal	PTFE
Valve body seal	PTFE

OTHER MATERIALS

Operator	Glass fibre filled PA
Optical position indicator	Optional on NC valves

⁽¹⁾ For dia. 32 operators: At service fluid temperatures inside the valve body above 100°C, it is prohibited to pilot the valve with water.

SPECIFICATIONS

piping (ISO 6708)		flow coefficient Kv		pilot pressure (bar)		operating pressure differential (bar)				operator diameter (mm)	catalogue number
pipe size (G)	DN	(m ³ /h)	(l/min)	min.	max.	min..	max.				
							air, inert gas, aggressive fluids (*)	water, oil, liquids, aggressive liquids (*)	steam (*) (≤184°C)		
NC - Normally closed, entry under the disc ⁽³⁾											
1/2	10	2,8	47	4	10	0	16	16	10	32	U290A791
3/4	15	4,1	68	4	10	0	12	12	10	32	U290A792
1	20	6,5	108	4	10	0	6	6	6	32	U290A793
NO - Normally open, entry under the disc											
1/2	10	2,8	47	IX (*)	10	0	16	16	10	32	U290A794
3/4	15	4,1	68	IX (*)	10	0	16	16	10	32	U290A795
1	20	6,5	108	IX (*)	10	0	16	16	10	32	U290A796
NC - Normally closed, entry above the disc (version recommended for rapid-cycling steam applications)											
1/2	10	2,8	47	X (*)	10	0	10	-	10	32	U290A797
3/4	15	4,1	68	X (*)	10	0	10	-	10	32	U290A798
1	20	6,5	108	X (*)	10	0	10	-	10	32	U290A799

(*) Minimum pilot pressure varies with differential pressure, see page: 7 (www.asco.com)

⁽³⁾ Calculation of the minimum pilot pressure at max. ΔP with allowable backpressure, contact us (backpressure not recommended with liquids as waterhammer may occur).

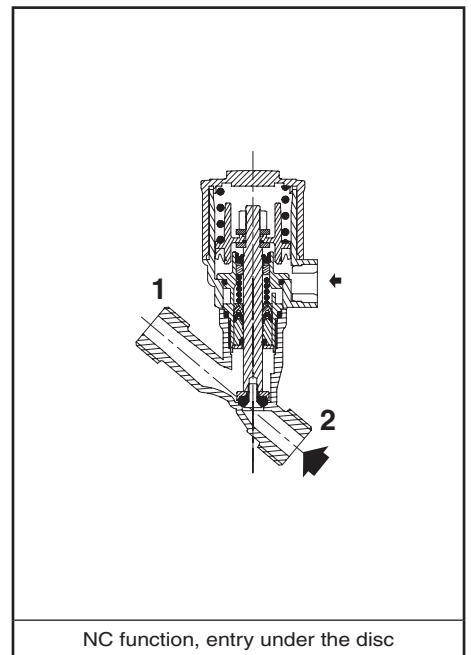

00050GB-2017/R01 Availability, design and specifications are subject to change without notice. All rights reserved.

OPTIONS AND ACCESSORIES [see pages: 37 (www.asco.com) / 43 (www.asco.com)]

- Optical position indicator, NC function
- Oxygen service, pressure limited to 15 bar, temperature limited to + 60°C
- Vacuum applications up to 1,33 10⁻³ mbar
- NET-INOX passivation treatment
- ATEX 2014/34/EU versions for potentially explosive atmospheres (www.asco.com)
- Other pipe connections are available on request

INSTALLATION

- The valves can be mounted in any position without affecting operation
- Compatible with ASTM 1, 2 and 3 oils
- Check temperature range of valve body and solenoid pilot valves for suitability. For probability of failure, contact us
- Pipe connection identifier is G = G (ISO 228/1)
- Installation/maintenance instructions are included with each valve

SPARE PARTS KITS

DN	spare parts kit no.	
		Ø 32 mm
10	C140100	
15	C140101	
20	C140102	

ORDERING EXAMPLES:

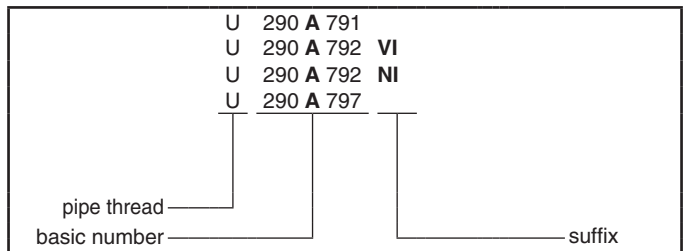

DIMENSIONS (mm), WEIGHT (kg)

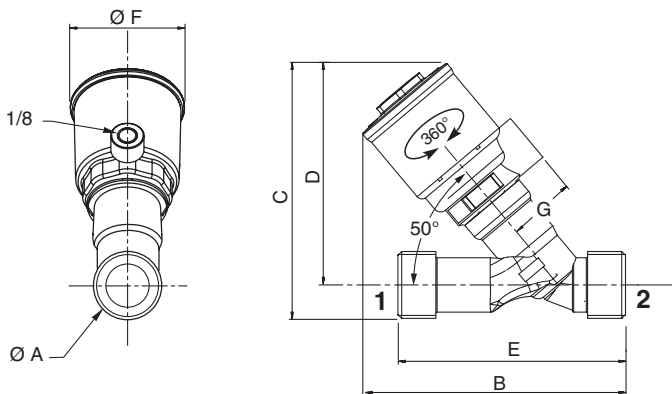
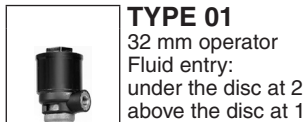

type	operator diameter	ØA	B	C	D	E	ØF	G	weight ⁽¹⁾
01	32 mm	1/2	102,5	98,2	87,7	80	43,5	27	0,36
		3/4	104,9	102	88,8	90	43,5	27	0,43
		1	109,5	104,9	88,4	110	43,5	27	0,54

⁽¹⁾ Weight of valve without pilot.
Solenoid pilot valves, see page: 49 (www.asco.com) [32 mm operator]

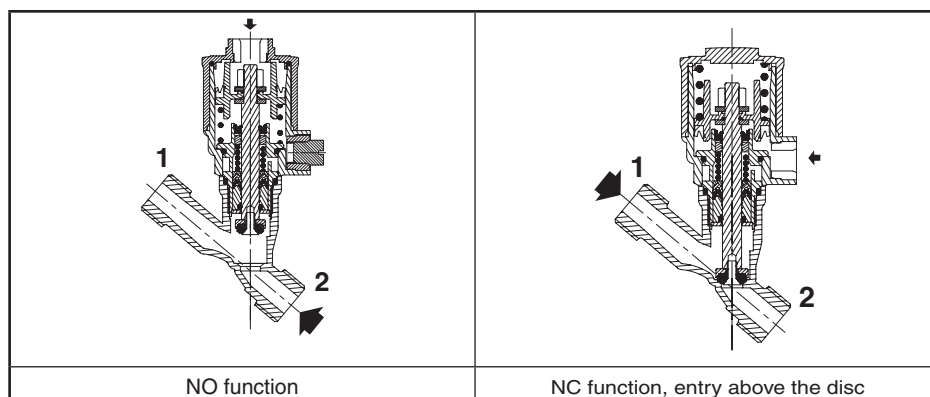



MINI-VALVES

pressure operated
stainless steel body

food connections to DIN 11851 - DN 10 to 20

NC

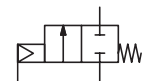

NO

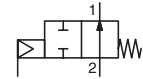

2/2
Series
Y290

FEATURES

- High flow due to angled seat design
- Anti-waterhammer design (fluid entry under the disc)
- External threads to DIN 11851
- Vacuum operation up to 10^{-2} mbar
- Piston-type operators 32 mm dia. rotatable through 360°
- Valve body pickled in nitric/fluoric acid bath (NET-INOX passivation treatment)
- High performance, maintenance-free stuffing box
- The valves satisfy Pressure Equipment Directive 2014/68/EU, article 4.3
- The valves in conformity with IEC 61508 Standard (2010 route 2_H version) certified with integrity levels: SIL 2 for HFT = 0

GENERAL

Differential pressure	See «SPECIFICATIONS» [1 bar = 100 kPa]
Maximum allowable pressure	16 bar
Ambient temperature range	-10°C to +60°C
Maximum viscosity	600 cSt (mm ² /s)
Pilot fluid	Filtered air or water ⁽¹⁾
Max. pilot pressure	10 bar
Min. pilot pressure	See below
Pilot fluid temperature	-10°C to +60°C
Response time	See page 7 (www.asco.com)

fluids (*)	temperature range	disc seal (*)
air and gas groups 1 & 2 water, oil, liquids groups 1 & 2 and steam	- 10°C to + 184°C	PTFE

MATERIALS IN CONTACT WITH FLUID

(*) Ensure that the compatibility of the fluids in contact with the materials is verified

Valve body	All AISI 316L
Stuffing box housing	AISI 316L ⁽²⁾
Stem	AISI 316L
Disc	AISI 316L
Stuffing box packing	PTFE chevrons
Wiper seal	FPM
Disc seal	PTFE
Valve body seal	PTFE

OTHER MATERIALS

Operator	Glass fibre filled PA
Optical position indicator	Optional on NC valves

⁽¹⁾ For dia. 32 operators: At service fluid temperatures inside the valve body above 100°C, it is prohibited to pilot the valve with water.
⁽²⁾ NET-INOX passivation treatment included.

SPECIFICATIONS

piping		flow coefficient Kv		pilot pressure (bar)		operating pressure differential (bar)				operator diameter (mm)	catalogue number
pipe size	DN	(m ³ /h)	(l/min)	min.	max.	min..	max.				
DIN 11851							air, inert gas, aggressive fluids (*)	water, oil, liquids, aggressive liquids (*)	steam (*) (≤184°C)		
NC - Normally closed, entry under the disc ⁽³⁾											
RD 28 x 1/8	10	2,8	47	4	10	0	16	16	10	32	Y290A791
RD 34 x 1/8	15	4,1	68	4	10	0	12	12	10	32	Y290A792
RD 44 x 1/6	20	6,5	108	4	10	0	6	6	6	32	Y290A793
NO - Normally open, entry under the disc											
RD 28 x 1/8	10	2,8	47	IX (*)	10	0	16	16	10	32	Y290A794
RD 34 x 1/8	15	4,1	68	IX (*)	10	0	16	16	10	32	Y290A795
RD 44 x 1/6	20	6,5	108	IX (*)	10	0	16	16	10	32	Y290A796
NC - Normally closed, entry above the disc (version recommended for rapid-cycling steam applications)											
RD 28 x 1/8	10	2,8	47	X (*)	10	0	10	-	10	32	Y290A797
RD 34 x 1/8	15	4,1	68	X (*)	10	0	10	-	10	32	Y290A798
RD 44 x 1/6	20	6,5	108	X (*)	10	0	10	-	10	32	Y290A799

(*) Minimum pilot pressure varies with differential pressure, see page: 7 (www.asco.com)

⁽³⁾ Calculation of the minimum pilot pressure at max. ΔP with allowable backpressure, contact us (backpressure not recommended with liquids as waterhammer may occur).

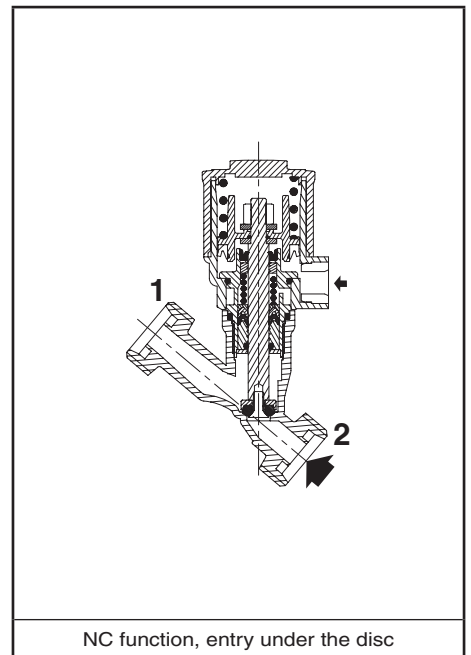

OPTIONS AND ACCESSORIES [see pages: 37 (www.asco.com) / 43 (www.asco.com)]

- Optical position indicator, NC function
- Oxygen service, pressure limited to 15 bar, temperature limited to + 60°C
- Vacuum applications up to 1,33 10⁻³ mbar
- ATEX 2014/34/EU versions for potentially explosive atmospheres (www.asco.com)
- Other pipe connections are available on request

INSTALLATION

- The valves can be mounted in any position without affecting operation
- Compatible with ASTM 1, 2 and 3 oils
- Check temperature range of valve body and solenoid pilot valves for suitability. For probability of failure, contact us
- Pipe connections have standard threads to DIN 11851
- Installation/maintenance instructions are included with each valve

SPARE PARTS KITS

DN	spare parts kit no.
10	C140100
15	C140101
20	C140102

ORDERING EXAMPLES:

	Y	290	A	791	
	Y	290	A	792	VI
	Y	290	A	799	

pipe thread ————
basic number ————
suffix ————

ORDERING EXAMPLES KITS:

	C140102
--	---------

basic number ————

DIMENSIONS (mm), WEIGHT (kg)

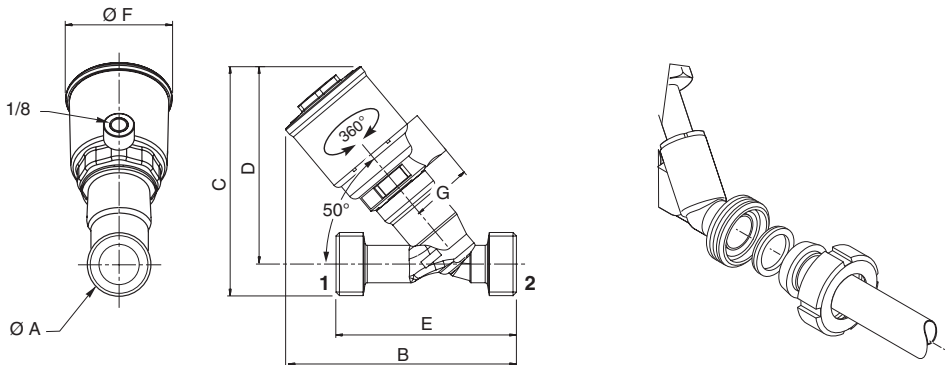
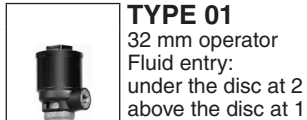

type	operator diameter	ØA	B	C	D	E	ØF	G	weight ⁽¹⁾
01	32 mm	RD 28 x 1/8	102,5	101,7	87,7	80	43,5	27	0,41
		RD 34 x 1/8	104,9	105,8	88,8	90	43,5	27	0,46
		RD 44 x 1/6	109,6	110,4	88,4	110	43,5	27	0,68

⁽¹⁾ Weight of valve without pilot.
Solenoid pilot valves, see page: 49 (www.asco.com) [32 mm operator]

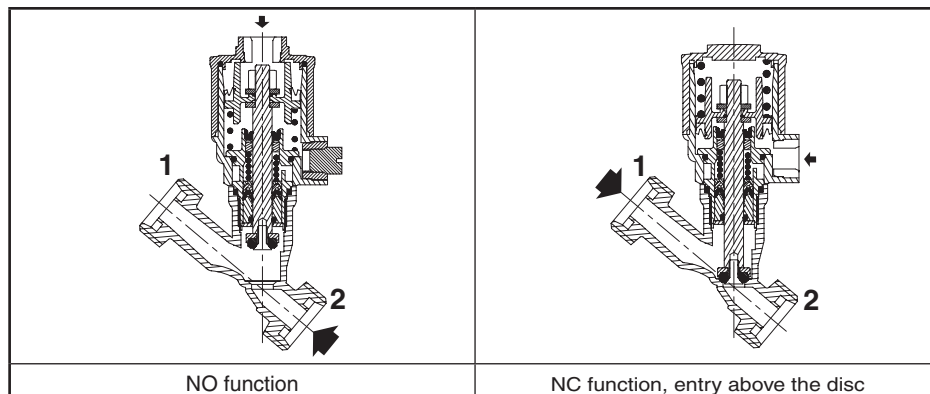



VALVES

pressure operated
stainless steel body
CLAMP or butt welding connection
DN 10 to 65

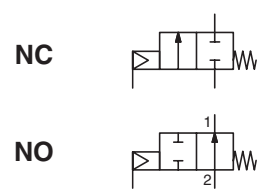

2/2
Series
S290

FEATURES

- Valve with clamp type connection to ISO 2852 for quick disconnection, a system commonly used in the food processing industry or with butt welding connection to ISO 6761 for stainless steel pipe to ISO 1127
- CLAMP valve body pickled in nitric/fluoric acid bath (NET-INOX passivation treatment)
- High flow due to angled seat design
- Anti-waterhammer design (fluid entry under the disc)
- Vacuum operation up to 10^{-2} mbar
- Wide range of piston-type operators (32 - 50- 63 - 90 -125 mm dia.) rotatable through 360°, for maximum performance at different minimum pilot pressures
- High performance, maintenance-free stuffing box
- The valves satisfy Pressure Equipment Directive 2014/68/EU, category 1 (DN > 25) or article 4.3 (DN ≤ 25)
- The valves in conformity with IEC 61508 Standard (2010 route 2_H version) certified with integrity levels: SIL 2 for HFT = 0



GENERAL

Differential pressure	See «SPECIFICATIONS» [1 bar =100 kPa]
Maximum allowable pressure	16 bar
Ambient temperature range	-10°C to +60°C
Maximum viscosity	600 cSt (mm ² /s)
Pilot fluid	Filtered air or water ⁽¹⁾
Max. pilot pressure	10 bar
Min. pilot pressure	See below and following page
Pilot fluid temperature	-10°C to +60°C
Response time	See page 7 (www.asco.com)

fluids (*)	temperature range	disc seal (*)
DN ≤ 50 : air et gaz groupes 1 & 2 DN 65: air and gas group 2 all DN: water, oil, liquids groups 1 & 2 and steam	- 10°C to + 184°C	PTFE

MATERIALS IN CONTACT WITH FLUID

(*) Ensure that the compatibility of the fluids in contact with the materials is verified

Valve body	AISI 316L (NET-INOX treatment)
CLAMP connection	AISI 316L
Butt welding connection	AISI 316L
Stuffing box housing	AISI 316L
Stem	Stainless steel
Disc	Stainless steel
Stuffing box packing	PTFE chevrons
Wiper seal	FPM
Disc seal	PTFE
Valve body seal	PTFE

OTHER MATERIALS

Operator	Glass fibre filled PA
Optical position indicator	PA 12, supplied standard on valves with 63, 90 and 125 mm operators

⁽¹⁾ For dia. 32, 50, 63, 90 and 125 mm operators: At service fluid temperatures inside the valve body above 100°C, it is prohibited to pilot the valve with water.

SPECIFICATIONS

DN	O.D. of stub (clamp) (mm)	O.D. of stub (butt) (mm)	flow coefficient Kv		pilot pressure (bar)		operating pressure differential (bar)			operator diameter (mm)	catalogue number		
							min.	max.			clamp connection	butt welding connection	
								air, inert gas, aggressive fluids(*)	water, oil, liquids, aggressive liquids(*)				steam (*) (≤184°C)
NC - Normally closed, entry under the disc ⁽¹⁾													
10	34	17,2	2,8	47	4	10	0	16	16	10	32	S290A800	S290A802
15	34	21,3	4,1	68	4	10	0	12	12	10	32	S290A804	S290A806
			4,9	82	4	10	0	16	16	10	50	S290A408	S290A417
			2,5	10	0	16	16	10	63	S290B137	S290B205		
20	50,5	26,9	6,5	108	4	10	0	6	6	6	32	S290A808	S290A810
			9,4	157	4	10	0	10	10	10	50	S290A409	S290A418
					16	16	10	63	S290B140	S290B208			
					2,5	10	0	12	12	10	63	S290B139	S290B207

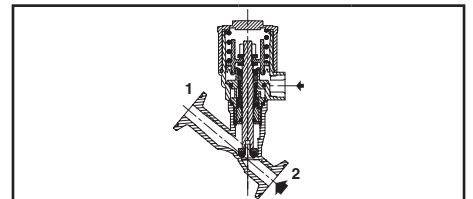

NC function, entry under the disc, 32 and 50 mm operators

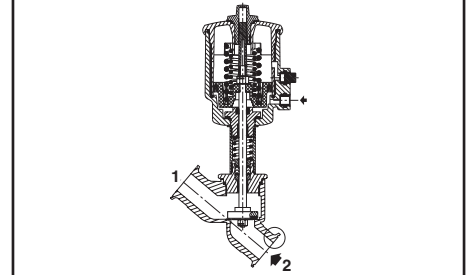

NC function, entry under the disc, 63, 90 and 125 mm operators

CLAMP connection (not supplied)

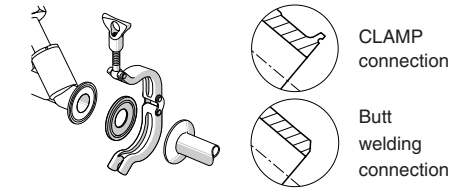

SPECIFICATIONS

DN	O.D. of sub (clamp) (mm)	O.D. of sub (butt) (mm)	flow coefficient Kv (m ³ /h) (l/min)		pilot pressure (bar) min. max.		operating pressure differential (bar)			operator diameter (mm)	catalogue number		
							min.	max.			clamp connection	butt welding connection	
								air, inert gas, aggressive fluids(*)	water, oil, liquids, aggressive liquids(*)				steam (*) (≤184°C)
NC - Normally closed, entry under the disc ⁽¹⁾													
25	50,5	33,7	12,8	213	4	10	0	6	6	6	50	S290A410	S290A419
					4	10	0	10	10	10	63	S290B145	S290B211
			16,5	275	2,5	10	0	6	6	6	63	S290B143	S290B210
					2,5	10	0	12	12	10	90	S290B144	-
32	64	42,4	27	450	4	10	0	6	6	6	63	S290A151	S290A215
					4	10	0	12	12	10	90	-	S290A216
			29	483	2,5	10	0	3	3	3	63	-	S290A214
					2,5	10	0	16	16	10	125	-	S290A670
40	64	48,3	45	750	4	10	0	4	4	4	63	S290A155	S290A217
					4	10	0	8	8	8	90	S290A156	S290A218
			48	800	2,5	10	0	4	4	4	90	S290A154	-
					2,5	10	0	16	16	10	125	S290A521	S290A573
50	77,5	60,3	59	983	4	10	0	2,5	2,5	2,5	63	S290A687	S290A719
					4	10	0	6	6	6	90	S290A688	S290A720
			66	1100	2,5	10	0	2,5	2,5	2,5	90	S290A685	-
					2,5	10	0	10	10	10	125	S290A689	S290A721
65	91	76,1	94	1567	4	10	0	2	2	2	90	S290A691	S290A722
					4	10	0	6	6	6	125	S290A690	-
			111	1850	2,5	10	0	1	1	1	125	S290A692	S290A723
					2,5	10	0	1	1	1	125	S290A692	S290A723
NO - Normally open, entry under the disc													
10	34	17,2	2,8	47	IX (*)	10	0	16	16	10	32	S290A812	S290A814
15	34	21,3	4,1	68	IX (*)	10	0	16	16	10	32	S290A816	S290A818
			4,9	82	I (*)	10	0	16	16	10	50	S290A411	S290A420
					II (*)	10	0	16	16	10	63	S290B161	S290B221
20	50,5	26,9	6,5	108	IX (*)	10	0	16	16	10	32	S290A820	S290A822
			9,4	157	I (*)	10	0	16	16	10	50	S290A412	S290A421
					II (*)	10	0	16	16	10	63	S290B162	S290B222
25	50,5	33,7	12,8	213	I (*)	10	0	16	16	10	50	S290A413	S290A422
			16,5	275	II (*)	10	0	16	16	10	63	S290B163	S290B223
32	64	42,4	27	450	II (*)	10	0	16	16	10	63	S290A164	S290A224
40	64	48,3	45	750	II (*)	10	0	11	11	10	63	S290A165	S290A225
50	77,5	60,3	59	983	II (*)	10	0	7	7	7	63	S290A693	S290A724
					III (*)	10	0	13	13	10	90	S290A694	S290A725
			94	1567	III (*)	10	0	7	7	7	90	S290A695	S290A726
65	91	76,1	111	1850	IV (*)	10	0	16	16	10	125	S290A696	S290A727
NC - Normally closed, entry above the disc (version recommended for rapid-cycling steam applications)													
10	34	17,2	2,8	47	X (*)	10	0	10	-	10	32	S290A824	S290A826
15	34	21,3	4,1	68	X (*)	10	0	10	-	10	32	S290A828	S290A830
			4,9	82	V (*)	10	0	10	-	10	50	S290A414	S290A423
					VI (*)	10	0	10	-	10	63	S290B167	S290B227
20	50,5	26,9	6,5	108	X (*)	10	0	10	-	10	32	S290A832	S290A834
			9,4	157	V (*)	10	0	10	-	10	50	S290A415	S290A424
					VI (*)	10	0	10	-	10	63	S290B168	S290B228
25	50,5	33,7	12,8	213	V (*)	10	0	10	-	10	50	S290A416	S290A425
			16,5	275	VI (*)	10	0	10	-	10	63	S290B169	S290B229
32	64	42,4	27	450	VI (*)	10	0	10	-	10	63	S290A170	S290A230
40	64	48,3	45	750	VI (*)	10	0	10	-	10	63	S290A171	S290A231
					VII (*)	10	0	10	-	10	90	-	S290A259
50	77,5	60,3	59	983	VI (*)	10	0	9	-	9	63	S290A697	S290A728
					VII (*)	10	0	10	-	10	90	S290A698	S290A729
65	91	76,1	94	1567	VII (*)	10	0	10	-	10	90	S290A699	S290A730
			111	1850	VIII (*)	10	0	10	-	10	125	S290A700	S290A731

(*) Minimum pilot pressure varies with differential pressure, see page: 7 (www.asco.com)

(1) Calculation of the minimum pilot pressure at a ΔP of max. 10 bar with allowable backpressure (backpressure not recommended with liquids as waterhammer may occur).

- 32 and 50 mm operators, 4 bar minimum pilot pressure version: add 2 bar to the minimum pilot pressure of chart V or X [see page: 7 (www.asco.com)]

- 63, 90 and 125 mm operators, 4 bar minimum pilot pressure version: add 1,5 bar to the minimum pilot pressure of chart VI, VII or VIII [see page: 7 (www.asco.com)]

OPTIONS AND ACCESSORIES [see pages: 37 (www.asco.com) / 43 (www.asco.com)]

- Signaling box or compact signaling unit
- Stroke limiter for opening
- Manual safety device
- Optical position indicator on 32-50 mm operators, NC function
- Adapter plate for NAMUR pad mounting pilot (63-90-125 mm operators only)
- Oxygen service (except DN 65), pressure limited to 15 bar, temperature limited to + 60°C
- Vacuum applications up to 1,33 10⁻³ mbar
- NET-INOX passivation treatment on valve body with butt welding connection
- ATEX 2014/34/EU versions for potentially explosive atmospheres (www.asco.com)

INSTALLATION

- The valves can be mounted in any position without affecting operation
- On clamp connection version: The connection stubs comply with ISO 2852.
The strength of the quick-disconnect connection clamp must be compatible with the maximum pressure applied to the valve
- On butt welding version: Compatible with ASTM 1, 2 and 3 oils
Butt welding connections comply with ISO 6761 and are compatible with pipe to ISO 1127
- Check temperature range of valve body and solenoid pilot valves for suitability. For probability of failure, contact us
- Installation/maintenance instructions are included with each valve

SPARE PARTS KITS

DN	spare parts kit no.	
	Ø 32 mm	Ø 50-63-90-125 mm
10	C140100	-
15	C140101	C131204 ⁽¹⁾
20	C140102	C131205 ⁽¹⁾
25	-	C131206 ⁽¹⁾
32	-	C131207 ⁽¹⁾
40	-	C131208 ⁽¹⁾
50	-	C131209 ⁽¹⁾
65	-	C131622 ⁽¹⁾

⁽¹⁾ Standard suffix VM also applies to kits. [see page: 37 (www.asco.com)].
- Not available

ORDERING EXAMPLES:

S	290	A	804
S	290	B	137 SM2
S	290	A	155 SU
S	290	A	170

pipe thread _____ suffix _____
basic number _____

ORDERING EXAMPLES KITS:

C140100	
C140205	
C140205	VM

basic number _____ suffix _____

DIMENSIONS (mm), WEIGHT



TYPE 01-02-03-04-05
clamp connection
32, 50, 63, 90 and 125 mm operators
Fluid entry: under the disc at 2
above the disc at 1

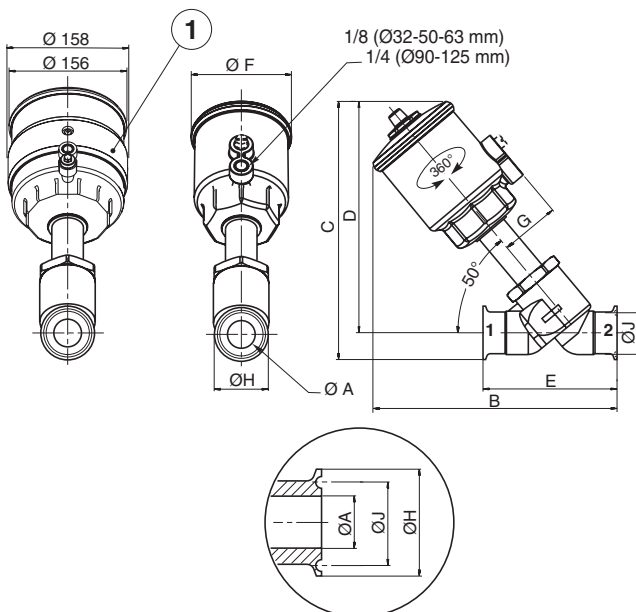

type	operator diameter	DN	ØA	B	C	D	E	ØF	G	ØH	ØJ	weight ⁽¹⁾
01	32	10	10	102,5	104,7	87,7	80	43,5	27	34	27,5	0,4
		15	16	110,7	105,8	88,8	101,6	43,5	27	34	27,5	0,43
		20	20	111,6	113,6	88,4	114	43,5	27	50,5	43,5	0,59
02	50	15	15,5	153	158,5	141	102	69	43	34	27,5	0,9
		20	21,5	158	168	143	114	69	43	50,5	43,5	1
03	63	25	26	167	170,5	145	129	69	43	50,5	43,5	1,4
		15	15,5	182	186	169	102	85	50,5	34	27,5	1,2
		20	21,5	184	195	170	114	85	50,5	50,5	43,5	1,3
		25	26	191	197	172	129	85	50,5	50,5	43,5	1,7
		32	35	226	236	204	140	85	50,5	64	56,5	2,1
		40	41	235	247	215	159	85	50,5	64	56,5	2,8
04	90	50	50	257	263	224	180	85	50,5	77,5	70,5	3,7
		25	26	209	214	189	129	118	67	50,5	43,5	2,2
		32	35	245	253	221	140	118	67	64	56,5	2,7
05	125	40	41	254	264	232	159	118	67	64	56,5	3,4
		50	50	275	280	241	180	118	67	77,5	70,5	4,2
		65	65	302	302,5	257	205	118	67	91	83,5	6,2
		32	35	291	307	273	140	156	86	64	56,5	5,2
		40	41	301	316	284	159	156	86	64	56,5	5,9
		50	50	322,5	332	293	180	156	86	77,5	70,5	6,7
		65	65	349,5	353,5	308	205	156	86	91	83,5	8,8

① Operator dia. 125 mm, NO function

⁽¹⁾ Weight of valve without pilot. Add 0,2 for dia. 125 mm operator NO
Solenoid pilot valves, see pages: 49 (www.asco.com) [32, 50 and 63 mm operators]
51 (www.asco.com) [90 and 125 mm operators]

All leaflets are available on: www.asco.com

DIMENSIONS (mm), WEIGHT

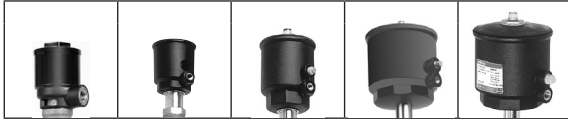

TYPE 01-02-03-04-05

butt welding connection
 32, 50, 63, 90 and 125 mm operators
 Fluid entry: under the disc at 2
 above the disc at 1

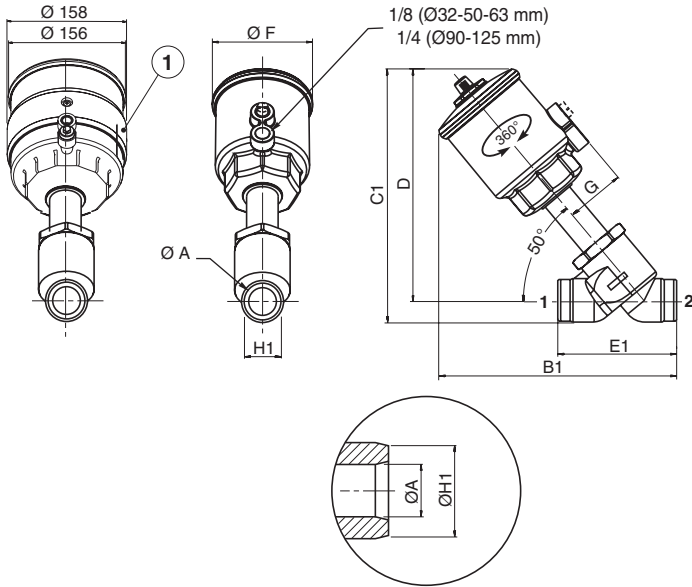

type	operator diameter	DN	ØA	B1	C1	D	E1	ØF	G	ØH1	weight ⁽¹⁾
01	32	10	10	102,5	96,9	87,7	80	43,5	27	17,2	0,37
		15	16	101,9	100,5	88,8	84	43,5	27	21,3	0,4
		20	20	103,6	102,4	88,4	98	43,5	27	26,9	0,45
02	50	15	15,5	144	152	141	84	69	43	21,3	0,9
		20	21,5	150	157	143	98	69	43	26,9	1
		25	26	159	162	145	113	69	43	33,7	1,3
03	63	15	15,5	172	181	169	84	85	50,5	21,3	1,2
		20	21,5	175	184	170	98	85	50,5	26,9	1,3
		25	26	183	190	172	113	85	50,5	33,7	1,6
		32	35	218	226	204	124	85	50,5	42,4	2
		40	41	227	240	215	143	85	50,5	48,3	2,7
04	90	50	50	249	254	224	164	85	50,5	60,3	3,6
		25	26	201	207	189	113	118	67	33,7	2,1
		32	35	237	243	221	124	118	67	42,4	2,6
		40	41	246	257	232	143	118	67	48,3	3,3
		50	50	267	271	241	164	118	67	60,3	4,1
05	125	65	65	294	295	257	189	118	67	76,1	6,1
		32	35	283	295	273	124	156	86	42,4	5,1
		40	41	294	308	284	143	156	86	48,3	5,8
		50	50	314,5	323	293	164	156	86	60,3	6,7
		65	65	341,5	346	308	189	156	86	76,1	8,7

① Operator dia. 125 mm, NO function

⁽¹⁾ Weight of valve without pilot. Add 0,2 for dia. 125 mm operator NO.
 Solenoid pilot valves, see pages: [49](#) (www.asco.com) [32, 50 and 63 mm operators]
[51](#) (www.asco.com) [90 and 125 mm operators]

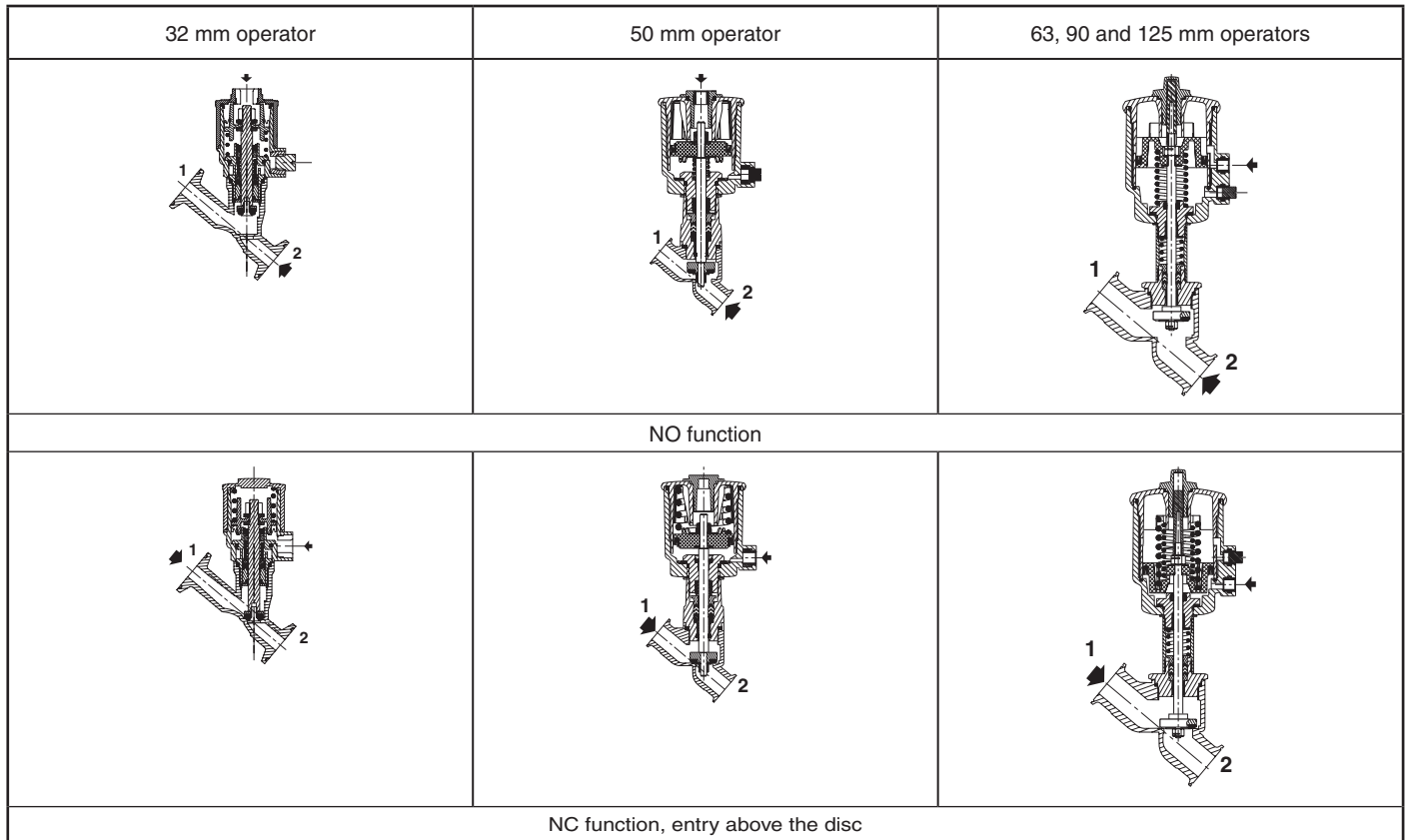



VALVES

pressure operated
Food contact version
stainless steel body, CLAMP or butt welding connection
DN 10 to 65

NC

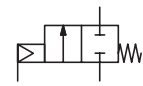

NO

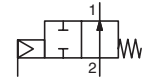

2/2
Series
S290

FEATURES

- Valve in conformity with Regulation (EC) 1935-2004, the material of the wetted parts are listed in the chart of the Annex I of Regulation (EC) 1935/2004
- All the material of the wetted parts are conform with FDA CFR21
- Valve with clamp type connection to ISO 2852 for quick disconnection, a system commonly used in the food processing industry or with butt welding connection to ISO 6761 for stainless steel pipe to ISO 1127
- CLAMP valve body pickled in nitric/fluoric acid bath (NET-INOX passivation treatment)
- High flow due to angled seat design
- Anti-waterhammer design (fluid entry under the disc)
- Vacuum operation up to 10^{-2} mbar
- Wide range of piston-type operators (32 - 50- 63 - 90 -125 mm dia.) rotatable through 360°, for maximum performance at different minimum pilot pressures
- High performance, maintenance-free stuffing box
- The valves satisfy Pressure Equipment Directive 2014/68/EU, category 1 (DN > 25) or article 4.3 (DN ≤ 25)
- The valves in conformity with IEC 61508 Standard (2010 route 2_H version) certified with integrity levels: SIL 2 for HFT = 0
- Valve in conformity with the provisions of the directive RoHS 2 (EU 2001/65)



GENERAL

Differential pressure	See «SPECIFICATIONS» [1 bar =100 kPa]
Maximum allowable pressure	16 bar
Ambient temperature range	-10°C to +60°C
Maximum viscosity	600 cSt (mm ² /s)
Pilot fluid	Filtered air or water ⁽¹⁾
Max. pilot pressure	10 bar
Min. pilot pressure	See below and following page
Pilot fluid temperature	-10°C to +60°C
Response time	See page 7 (www.asco.com)

fluids (*)	temperature range	disc seal (*)
DN ≤ 50 : air et gaz groupes 1 & 2 DN 65: air and gas group 2 all DN: water, oil, liquids groups 1 & 2 and steam	- 10°C to + 184°C	PTFE

MATERIALS IN CONTACT WITH FLUID

(*) Ensure that the compatibility of the fluids in contact with the materials is verified

Valve body	CLAMP connection Butt welding connection	AISI 316L (NET-INOX treatment) AISI 316L
Stuffing box housing		AISI 316L (+ NET-INOX treatment on CLAMP)
Stem		Stainless steel
Disc		Stainless steel
Stuffing box packing		PTFE chevrons
Wiper seal		PTFE
Disc seal		PTFE
Valve body seal		PTFE

OTHER MATERIALS

Operator	Glass fibre filled PA
Optical position indicator	PA 12, supplied standard on valves with 63, 90 and 125 mm operators

⁽¹⁾ For dia. 32, 50, 63, 90 and 125 mm operators: At service fluid temperatures inside the valve body above 100°C, it is prohibited to pilot the valve with water.

SPECIFICATIONS

DN	O.D. of stub (clamp) (mm)	O.D. of stub (butt) (mm)	flow coefficient Kv		pilot pressure (bar)		operating pressure differential (bar)			operator diameter (mm)	catalogue number		
			(m ³ /h)	(l/min)	min.	max.	max.				clamp connection	butt welding connection	
							air, inert gas, aggressive fluids(*)	water, oil, liquids, aggressive liquids(*)	steam (*) (≤184°C)				
NC - Normally closed, entry under the disc ⁽¹⁾													
10	34	17,2	2,8	47	4	10	0	16	16	10	32	S290A800FB	S290A802FB
			4,1	68	4	10	0	12	12	10	32	S290A804FB	S290A806FB
15	34	21,3	4,9	82	4	10	0	16	16	10	50	S290A408FB	S290A417FB
					2,5	10	0	16	16	10	63	S290B137FB	S290B205FB
			6,5	108	4	10	0	6	6	6	32	S290A808FB	S290A810FB
			9,4	157	4	10	0	10	10	10	50	S290A409FB	S290A418FB
								16	16	10	63	S290B140FB	S290B208FB

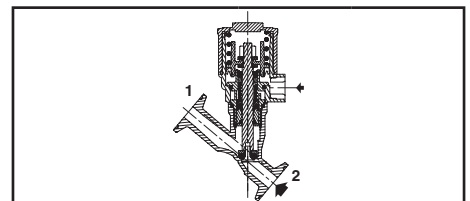

NC function, entry under the disc, 32 and 50 mm operators

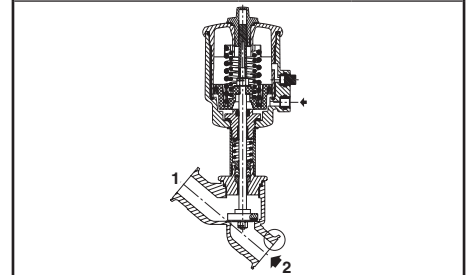

NC function, entry under the disc, 63, 90 and 125 mm operators

CLAMP connection (not supplied)

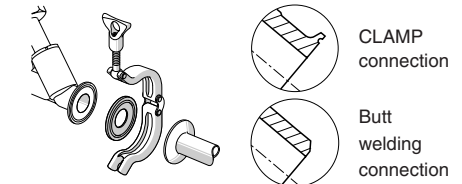

SPECIFICATIONS

DN	O.D. of stub (clamp) (mm)	O.D. of stub (butt) (mm)	flow coefficient Kv (m ³ /h) (l/min)		pilot pressure (bar) min. max.		operating pressure differential (bar)			operator diameter (mm)	catalogue number		
							min.	max.			clamp connection	butt welding connection	
								air, inert gas, aggressive fluids(*)	water, oil, liquids, aggressive liquids(*)				steam (*) (≤184°C)
NC - Normally closed, entry under the disc ⁽¹⁾													
25	50,5	33,7	12,8	213	4	10	0	6	6	6	50	S290A410FB	S290A419FB
			16,5	275	4	10	0	10	10	10	63	S290B145FB	S290B211FB
32	64	42,4	27	450	4	10	0	16	16	10	90	S290B146FB	S290B212FB
			29	483	4	10	0	6	6	6	63	S290A151FB	S290A215FB
								12	12	10	90	-	S290A216FB
40	64	48,3	45	750	4	10	0	16	16	10	125	-	S290A670FB
			48	800	4	10	0	4	4	4	63	S290A155FB	S290A217FB
								8	8	8	90	S290A156FB	S290A218FB
50	77,5	60,3	59	983	4	10	0	16	16	10	125	S290A521FB	S290A573FB
			66	1100	4	10	0	2,5	2,5	2,5	63	S290A687FB	S290A719FB
			94	1567	4	10	0	6	6	6	90	S290A688FB	S290A720FB
65	91	76,1	111	1850	4	10	0	10	10	10	125	S290A689FB	S290A721FB
								2	2	2	90	S290A691FB	S290A722FB
NO - Normally open, entry under the disc													
10	34	17,2	2,8	47	IX (*)	10	0	16	16	10	32	S290A812FB	S290A814FB
15	34	21,3	4,1	68	IX (*)	10	0	16	16	10	32	S290A816FB	S290A818FB
			4,9	82	I (*)	10	0	16	16	10	50	S290A411FB	S290A420FB
20	50,5	26,9	6,5	108	IX (*)	10	0	16	16	10	32	S290A820FB	S290A822FB
			9,4	157	I (*)	10	0	16	16	10	50	S290A412FB	S290A421FB
								II (*)	10	0	16	16	10
25	50,5	33,7	16,5	275	II (*)	10	0	16	16	10	63	S290B163FB	S290B223FB
32	64	42,4	27	450	II (*)	10	0	16	16	10	63	S290A164FB	S290A224FB
40	64	48,3	45	750	II (*)	10	0	11	11	10	63	S290A165FB	S290A225FB
50	77,5	60,3	59	983	III (*)	10	0	13	13	10	90	S290A694FB	S290A725FB
65	91	76,1	94	1567	III (*)	10	0	7	7	7	90	S290A695FB	S290A726FB
			111	1850	IV (*)	10	0	16	16	10	125	S290A696FB	S290A727FB
NC - Normally closed, entry above the disc (version recommended for rapid-cycling steam applications)													
10	34	17,2	2,8	47	X (*)	10	0	10	-	10	32	S290A824FB	S290A826FB
15	34	21,3	4,1	68	X (*)	10	0	10	-	10	32	S290A828FB	S290A830FB
			4,9	82	V (*)	10	0	10	-	10	50	S290A414FB	S290A423FB
								VI (*)	10	0	10	63	S290B167FB
20	50,5	26,9	6,5	108	X (*)	10	0	10	-	10	32	S290A832FB	S290A834FB
			9,4	157	V (*)	10	0	10	-	10	50	S290A415FB	S290A424FB
					VI (*)	10	0	10	-	10	63	S290B168FB	S290B228FB
25	50,5	33,7	12,8	213	V (*)	10	0	10	-	10	50	S290A416FB	S290A425FB
			16,5	275	VI (*)	10	0	10	-	10	63	S290B169FB	S290B229FB
32	64	42,4	27	450	VI (*)	10	0	10	-	10	63	S290A170FB	S290A230FB
40	64	48,3	45	750	VI (*)	10	0	10	-	10	63	S290A171FB	S290A231FB
								VII (*)	10	0	10	90	-
50	77,5	60,3	59	983	VI (*)	10	0	9	-	9	63	S290A697FB	S290A728FB
								VII (*)	10	0	10	90	S290A698FB
65	91	76,1	94	1567	VII (*)	10	0	10	-	10	90	S290A699FB	S290A730FB
			111	1850	VIII (*)	10	0	10	-	10	125	S290A700FB	S290A731FB

 (*): Minimum pilot pressure varies with differential pressure, see page: 7 (www.asco.com)

(1) Calculation of the minimum pilot pressure at a ΔP of max. 10 bar with allowable backpressure (backpressure not recommended with liquids as waterhammer may occur).

 - 32 and 50 mm operators, 4 bar minimum pilot pressure version: add 2 bar to the minimum pilot pressure of chart V or X [see page: 7 (www.asco.com)]

 - 63, 90 and 125 mm operators, 4 bar minimum pilot pressure version: add 1,5 bar to the minimum pilot pressure of chart VI, VII or VIII [see page: 7 (www.asco.com)]

OPTIONS AND ACCESSORIES [see pages: 37 (www.asco.com) / 43 (www.asco.com)]

- Signaling box or compact signaling unit
- Stroke limiter for opening
- Manual safety device
- Optical position indicator on 32-50 mm operators, NC function
- Adapter plate for NAMUR pad mounting pilot (63-90-125 mm operators only)
- NET-INOX passivation treatment on valve body with butt welding connection
- ATEX 2014/34/EU versions for potentially explosive atmospheres (www.asco.com)

INSTALLATION

- The valves can be mounted in any position without affecting operation
- On clamp connection version: The connection stubs comply with ISO 2852.
The strength of the quick-disconnect connection clamp must be compatible with the maximum pressure applied to the valve
- On butt welding version: Compatible with ASTM 1, 2 and 3 oils
Butt welding connections comply with ISO 6761 and are compatible with pipe to ISO 1127
- Check temperature range of valve body and solenoid pilot valves for suitability. For probability of failure, contact us
- Installation/maintenance instructions are included with each valve

SPARE PARTS KITS

DN	spare parts kit no.	
	Ø 32 mm	Ø 50-63-90-125 mm
10	C140100FB	-
15	C140101FB	C131204FB
20	C140102FB	C131205FB
25	-	C131206FB
32	-	C131207FB
40	-	C131208FB
50	-	C131209FB
65	-	C131622FB

- Not available

ORDERING EXAMPLES:

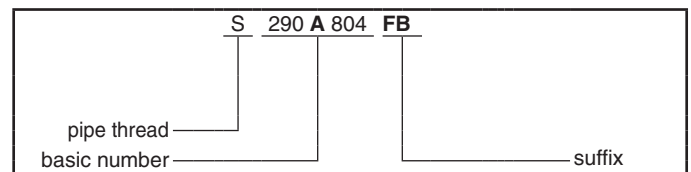

ORDERING EXAMPLES KITS:

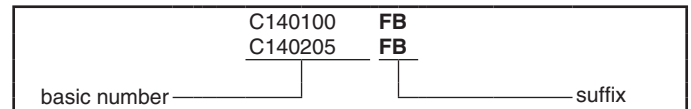

DIMENSIONS (mm), WEIGHT



TYPE 01-02-03-04-05

clamp connection
 32, 50, 63, 90 and 125 mm operators
 Fluid entry: under the disc at 2
 above the disc at 1

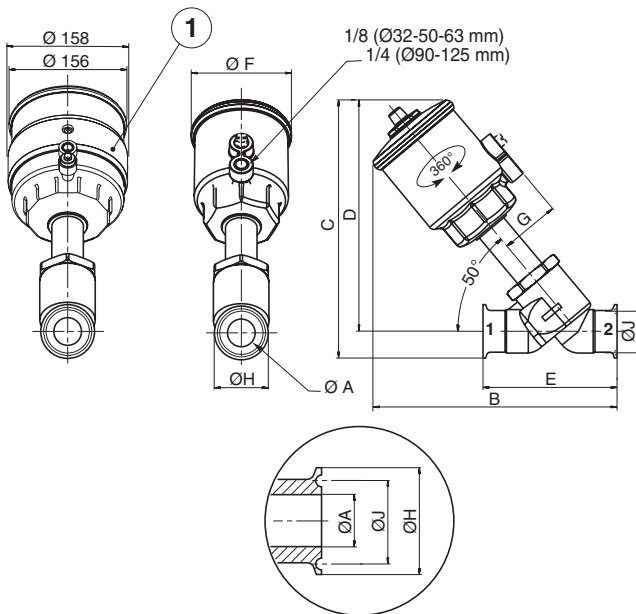

① Operator dia. 125 mm, NO function

type	operator diameter	DN	ØA	B	C	D	E	ØF	G	ØH	ØJ	weight ⁽¹⁾
01	32	10	10	102,5	104,7	87,7	80	43,5	27	34	27,5	0,4
		15	16	110,7	105,8	88,8	101,6	43,5	27	34	27,5	0,43
		20	20	111,6	113,6	88,4	114	43,5	27	50,5	43,5	0,59
02	50	15	15,5	153	158,5	141	102	69	43	34	27,5	0,9
		20	21,5	158	168	143	114	69	43	50,5	43,5	1
		25	26	167	170,5	145	129	69	43	50,5	43,5	1,4
03	63	15	15,5	182	186	169	102	85	50,5	34	27,5	1,2
		20	21,5	184	195	170	114	85	50,5	50,5	43,5	1,3
		25	26	191	197	172	129	85	50,5	50,5	43,5	1,7
		32	35	226	236	204	140	85	50,5	64	56,5	2,1
		40	41	235	247	215	159	85	50,5	64	56,5	2,8
04	90	50	50	257	263	224	180	85	50,5	77,5	70,5	3,7
		25	26	209	214	189	129	118	67	50,5	43,5	2,2
		32	35	245	253	221	140	118	67	64	56,5	2,7
		40	41	254	264	232	159	118	67	64	56,5	3,4
		50	50	275	280	241	180	118	67	77,5	70,5	4,2
05	125	65	65	302	302,5	257	205	118	67	91	83,5	6,2
		32	35	291	307	273	140	156	86	64	56,5	5,2
		40	41	301	316	284	159	156	86	64	56,5	5,9
		50	50	322,5	332	293	180	156	86	77,5	70,5	6,7
		65	65	349,5	353,5	308	205	156	86	91	83,5	8,8

⁽¹⁾ Weight of valve without pilot. Add 0,2 for dia. 125 mm operator NO.

Solenoid pilot valves, see pages: 49 (www.asco.com) [32, 50 and 63 mm operators]

51 (www.asco.com) [90 and 125 mm operators]

DIMENSIONS (mm), WEIGHT

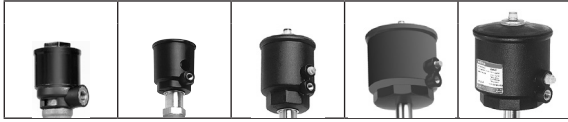

TYPE 01-02-03-04-05

butt welding connection
32, 50, 63, 90 and 125 mm operators
Fluid entry: under the disc at 2
above the disc at 1

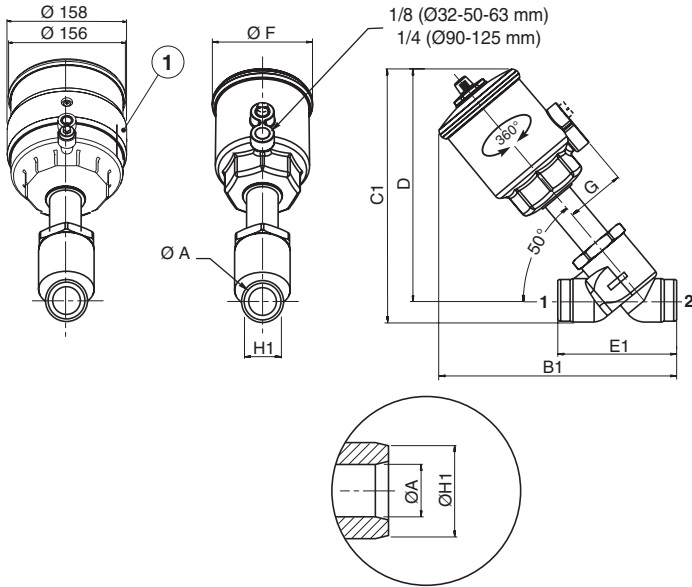

type	operator diameter	DN	ØA	B1	C1	D	E1	ØF	G	ØH1	weight ⁽¹⁾
01	32	10	10	102,5	96,9	87,7	80	43,5	27	17,2	0,37
		15	16	101,9	100,5	88,8	84	43,5	27	21,3	0,4
		20	20	103,6	102,4	88,4	98	43,5	27	26,9	0,45
02	50	15	15,5	144	152	141	84	69	43	21,3	0,9
		20	21,5	150	157	143	98	69	43	26,9	1
		25	26	159	162	145	113	69	43	33,7	1,3
03	63	15	15,5	172	181	169	84	85	50,5	21,3	1,2
		20	21,5	175	184	170	98	85	50,5	26,9	1,3
		25	26	183	190	172	113	85	50,5	33,7	1,6
		32	35	218	226	204	124	85	50,5	42,4	2
		40	41	227	240	215	143	85	50,5	48,3	2,7
04	90	50	50	249	254	224	164	85	50,5	60,3	3,6
		25	26	201	207	189	113	118	67	33,7	2,1
		32	35	237	243	221	124	118	67	42,4	2,6
		40	41	246	257	232	143	118	67	48,3	3,3
		50	50	267	271	241	164	118	67	60,3	4,1
05	125	65	65	294	295	257	189	118	67	76,1	6,1
		32	35	283	295	273	124	156	86	42,4	5,1
		40	41	294	308	284	143	156	86	48,3	5,8
		50	50	314,5	323	293	164	156	86	60,3	6,7
		65	65	341,5	346	308	189	156	86	76,1	8,7

① Operator dia. 125 mm, NO function

⁽¹⁾ Weight of valve without pilot. Add 0,2 for dia. 125 mm operator NO.
Solenoid pilot valves, see pages: [49](#) (www.asco.com) [32, 50 and 63 mm operators]
[51](#) (www.asco.com) [90 and 125 mm operators]

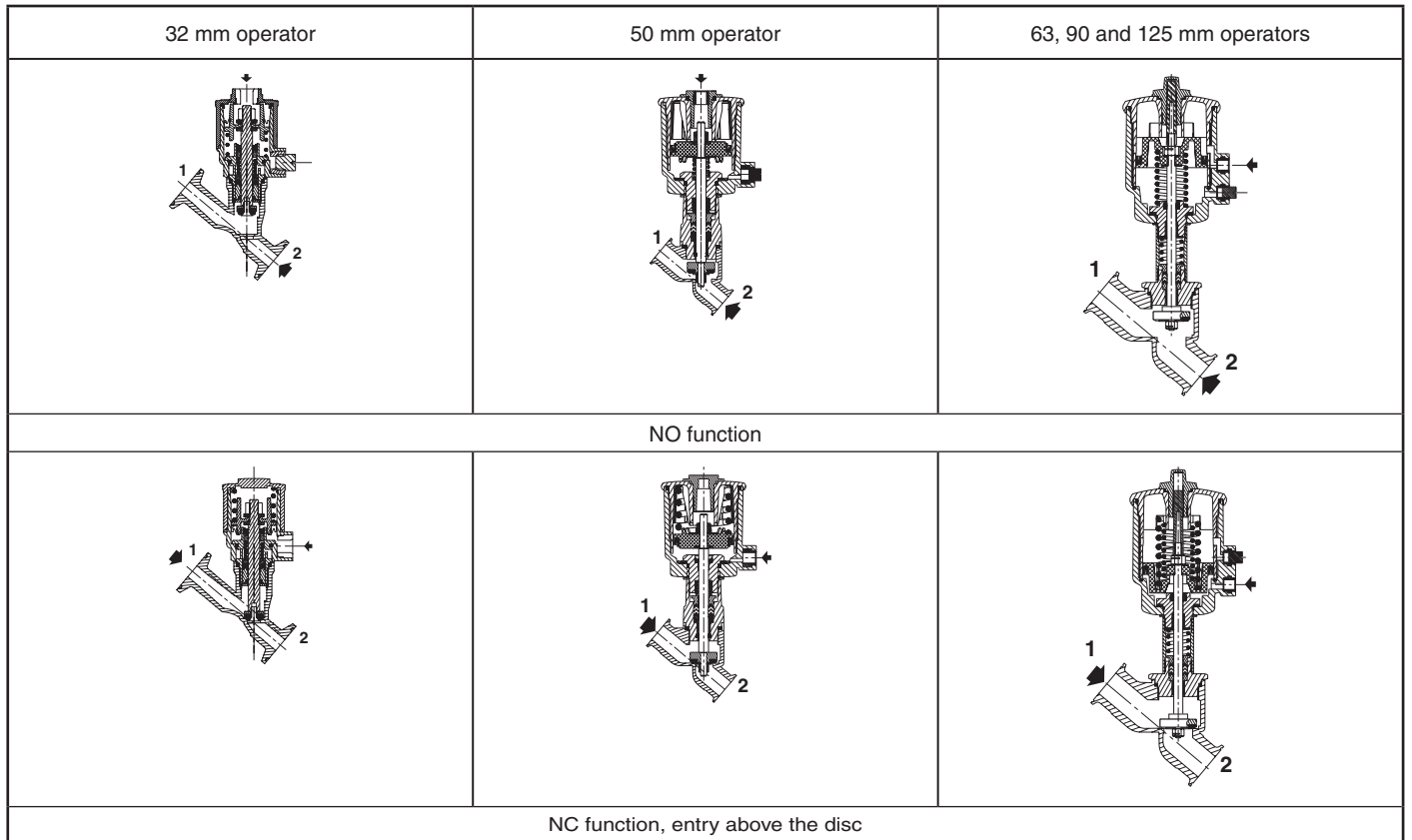



VALVES

pressure operated
bronze body
with flanges PN16, DN 25 to 50

NC

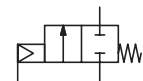

NO

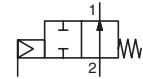

2/2
Series
T290

FEATURES

- Remote-controlled valves with disc for industrial fluids
- Anti-waterhammer design (fluid entry under the disc)
- Vacuum operation up to 10⁻² mbar
- Wide range of piston-type operators (63 - 90 - 125 mm dia.) rotatable through 360°, for maximum performance at different minimum pilot pressures
- High performance, maintenance-free stuffing box
- The valves satisfy Pressure Equipment Directive 2014/68/EU, category 1 (DN > 25) or article 4.3 (DN 25)
- The valves in conformity with IEC 61508 Standard (2010 route 2_H version) certified with integrity levels: SIL 2 for HFT = 0

GENERAL

Differential pressure	See «SPECIFICATIONS» [1 bar = 100 kPa]
Maximum allowable pressure	16 bar
Ambient temperature range	-10°C to +60°C
Maximum viscosity	600 cSt (mm ² /s)
Pilot fluid	Filtered air or water ⁽¹⁾
Max. pilot pressure	10 bar
Min. pilot pressure	See below and following page
Pilot fluid temperature	-10°C to +60°C
Response time	See page 7 (www.asco.com)

fluids (*)	temperature range	disc seal (*)
air and gas groups 1 & 2 water, oil, liquids groups 1 & 2 and steam	- 10°C to + 184°C	PTFE

CONSTRUCTION

Connection Flange type 21 (ISO 7005) - PN 16
Facing Type A

MATERIALS IN CONTACT WITH FLUID

(*) Ensure that the compatibility of the fluids in contact with the materials is verified

Valve body	Bronze
Stuffing box housing	Brass
Stem	Stainless steel
Disc	Brass
Stuffing box packing	PTFE chevrons
Wiper seal	FPM
Disc seal	PTFE
Valve body seal	PTFE

OTHER MATERIALS

Operator Glass fibre filled PA
Optical position indicator PA 12, supplied standard on valves with 63, 90 and 125 mm operators

⁽¹⁾ For dia. 63, 90 and 125 mm operators: At service fluid temperatures inside the valve body above 100°C, it is prohibited to pilot the valve with water.

SPECIFICATIONS

DN	orifice size (mm)	flow coefficient Kv (m ³ /h) (l/min)		pilot pressure (bar) min. max.		operating pressure differential (bar)			operator diameter (mm)	catalogue number	
						min.	max.				
							air inert gas (*)	water, oil, liquids (*)			steam (*) (≤184°C)
NC - Normally closed, entry under the disc ⁽¹⁾											
25	25	12	200	4	10	0	10	10	10	63	T290A010
							16	16	10	90	T290A011
				2,5	10	0	6	6	6	63	T290A008
							12	12	10	90	T290A009
32	32	18	300	4	10	0	6	6	6	63	T290A016
							12	12	10	90	T290A017
				2,5	10	0	7	7	7	90	T290A015
							4	4	4	63	T290A020
40	40	32	530	4	10	0	8	8	8	90	T290A021
							16	16	10	125	T290A482
		35	583	2,5	10	0	10	10	10	125	T290A481
							2,5	2,5	2,5	63	T290A024
50	50	39	650	4	10	0	6	6	6	90	T290A025
							10	10	10	125	T290A485
		44	733	2,5	10	0	5	5	5	125	T290A484
							NO - Normally open, entry under the disc				
25	25	12	200	II (*)	10	0	16	16	10	63	T290A028
				III (*)	10	0	16	16	10	90	T290A029
32	32	18	300	II (*)	10	0	16	16	10	63	T290A030
		19	317	IV (*)	10	0	16	16	10	125	T290A643

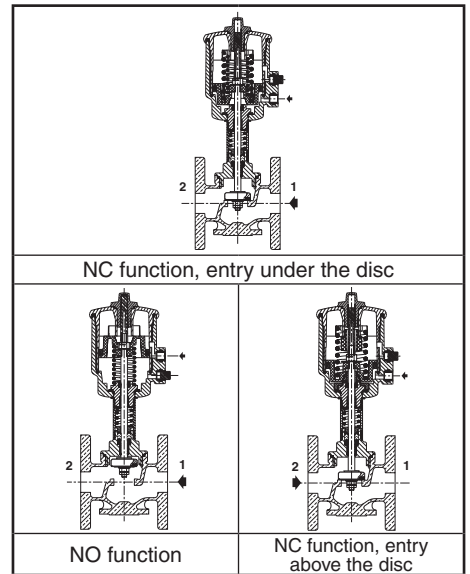

SPECIFICATIONS

DN	orifice size (mm)	flow coefficient Kv (m ³ /h) (l/min)		pilot pressure (bar) min. max.		operating pressure differential (bar)			operator diameter (mm)	catalogue number	
						min.	max.				
							air inert gas (*)	water, oil, liquids (*)			steam (*) (≤184°C)
NO - Normally open, entry under the disc											
40	40	32	530	II (*)	10	0	11	11	10	63	T290A032
				III (*)	10	0	16	16	10	90	T290A033
		35	583	IV (*)	10	0	16	16	10	125	T290A489
50	50	39	650	III (*)	10	0	13	13	10	90	T290A035
		44	733	IV (*)	10	0	16	16	10	125	T290A490
NC - Normally closed, entry above the disc (version recommended for rapid-cycling steam applications)											
25	25	12	200	VI (*)	10	0	10	-	10	63	T290A038
32	32	18	300	VI (*)	10	0	10	-	10	63	T290A039
				VII (*)	10	0	10	-	10	90	T290A136
40	40	32	530	VI (*)	10	0	10	-	10	63	T290A040
				VII (*)	10	0	10	-	10	90	T290A041
50	50	39	650	VI (*)	10	0	9	-	9	63	T290A042
				VII (*)	10	0	10	-	10	90	T290A043

(*) Minimum pilot pressure varies with differential pressure, see page: 7 (www.asco.com)

(1) Calculation of the minimum pilot pressure at a ΔP of max. 10 bar with allowable backpressure (backpressure not recommended with liquids as waterhammer may occur) - 63, 90 and 125 mm operators, 4 bar minimum pilot pressure version: add 1,5 bar to the minimum pilot pressure of chart VI, VII or VIII [see page: 7 (www.asco.com)]

OPTIONS AND ACCESSORIES [see pages: 37 (www.asco.com) / 43 (www.asco.com)]

- Signaling box or compact signaling unit
- Stroke limiter for opening
- Manual safety device
- Adapter plate for NAMUR pad mounting pilot
- Oxygen service, pressure limited to 15 bar, temperature limited to + 60°C
- Vacuum applications up to 1,33 10⁻³ mbar
- ATEX 2014/34/EU versions for potentially explosive atmospheres (www.asco.com)

INSTALLATION

- The valves can be mounted in any position without affecting operation
- Compatible with ASTM 1, 2 and 3 oils
- Check temperature range of valve body and solenoid pilot valves for suitability. For probability of failure, contact us
- Installation/maintenance instructions are included with each valve

SPARE PARTS KITS

DN	spare parts kit no.
	Ø 63-90-125 mm
25	C140017 ⁽²⁾
32	C140018 ⁽²⁾
40	C140019 ⁽²⁾
50	C140020 ⁽²⁾

(2) Standard suffix VM also applies to kits. [see page: 37 (www.asco.com)].

DIMENSIONS (mm), WEIGHT

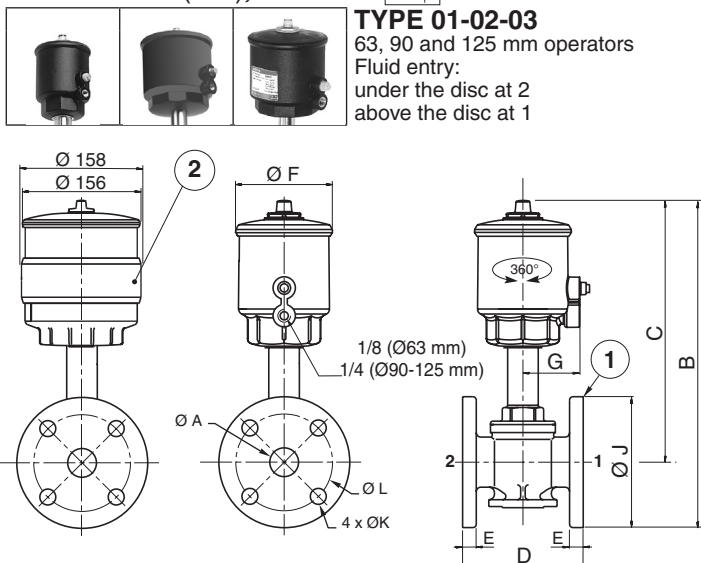

- (1) Flange type 21 with flat faces, type A (ISO 7005)
- (2) Operator dia. 125 mm, NO function

ORDERING EXAMPLES:

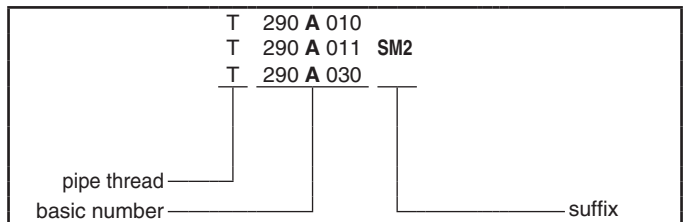

ORDERING EXAMPLES KITS:

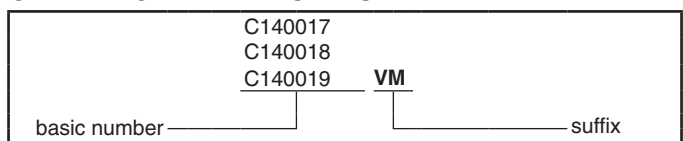

type	operator diameter	ØA	B	C	D	E	ØF	G	ØJ	ØK	ØL	weight ⁽³⁾
01	63	25	288	230	110	12	85	50,5	115	14	85	3,9
		32	313	243	130	14	85	50,5	140	18	100	5,9
		40	329	254	140	14	85	50,5	150	18	110	7,1
		50	354	271	160	16	85	50,5	165	18	125	10,5
02	90	25	303	246	110	12	118	67	115	14	85	4,5
		32	325	255	130	14	118	67	140	18	100	6,5
		40	341	266	140	14	118	67	150	18	110	7,7
03	125	50	365	283	160	16	118	67	165	18	125	11,1
		32	378	308	130	14	156	86	140	18	100	9
		40	394	319	140	14	156	86	150	18	110	10,2
		50	418	336	160	16	156	86	165	18	125	13,6

(3) Weight of valve without pilot. Add 0,2 for dia. 125 mm operator NO.

Solenoid pilot valves, see pages: 49 (www.asco.com) [63 mm operator]













51 (www.asco.com) [90 and 125 mm operators]







All leaflets are available on: www.asco.com

GENERAL / CONSTRUCTION / SPECIFICATIONS

See catalogue pages "Pressure Operated Valves (2/2)": 15, 19, 23, 25, 27, 31, 35
 "Pressure Operated Valves (3/2)": 1

CHOICE OF OPTIONS AND ACCESSORIES

construction type	see page	catalogue page										operator dia. compatibility (mm) Ø			body						
		15	19	23	25	27	31	35	1 (3/2 section)	fluid entry under the disc	fluid entry under the disc	fluid entry above the disc	32	50	63	90	125	bronze	stainless steel	cast iron	
 01 Signaling box, with mechanical or inductive contacts	39	EE	EE	EE		II	II	II	II	II	II	II	EE						///	///	///
 02 Signaling unit for dia. 32 mm operators, with reed switch or magneto-resistive (MR) detectors	41	EE	EE	EE	EE	II	II	II	II	II	II	II	EE						///	///	///
 03 Signaling unit for dia. 50, 63, 90 and 125 mm operators, with reed switch or magneto-resistive (MR) detectors	39	EE	EE			II	II	II	II	II	II	II	EE						///	///	///
 04 Stroke limiter for opening	38	EE	EE			II	II	II	II	II	II	II	EE						///	///	///
 05 Manual safety device	38	EE	EE			II	II	II	II	II	II	II	EE						///	///	///
 06 Optical position indicator (Ø 32-50 mm) (Standard on dia. 63, 90 and 125 mm operators)	38	EE	EE	EE	EE	II	II	II	II	II	II	II	EE						///	///	///
 07 Adapter plate for NAMUR pad-mount pilot	38	EE	EE			II	II	II	II	II	II	II	EE						///	///	///
 08 Oxygen service (max. limits: 15 bar, +60°C)	38	EE		EE	EE	II	II	II	II	II	II	II	EE						///	///	///
 09 Vacuum applications up to 1.33 10 ⁻³ mbar	38	EE		EE	EE	II	II	II	II	II	II	II	EE						///	///	///
 10 NET-INOX treatment	38	EE	EE	EE		II	II	II	II	II	II	II	EE						///	///	///
 11 Conformity with Regulation (EC) 1935-2004	38		EE	EE	EE		II	II	II	II	II	II	EE						///	///	///
 12 All stainless steel AISI 316L version (Recommended for aggressive environments) For valve catalogue numbers = contact us																					

 Valves with female threaded ports.
  Valves with butt welding connection
  Valves with CLAMP connection
 Valves with male threaded ports
  Valves with flange connection.
  Valves with male threaded ports DIN 11851

00055GB-2017/R01 Availability, design and specifications are subject to change without notice. All rights reserved.



CONSTRUCTION 04

Stroke limiter for opening

- Fluid entry under the disc only
- Operator diameters 50 (NC), 63, 90 and 125 mm

TO ORDER: (for compatibility: see page 37)

- Add suffix **M**

ORDERING EXAMPLES:

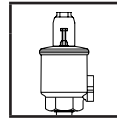
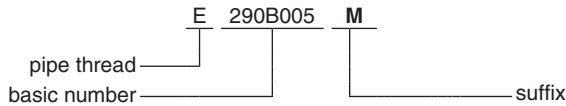

CONSTRUCTION 05

Manual safety device

- Allows opening of a de-energized valve
- For normally closed (NC) valves only

TO ORDER: (for compatibility: see page 37)

- Add suffix **MS**

ORDERING EXAMPLES:

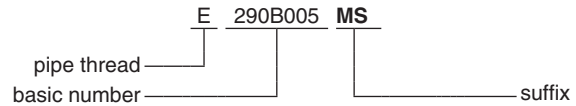

CONSTRUCTION 06

Optical position indicator

- Visual indication of open or closed position of NC valves with Ø 32 or 50 mm operator (standard with dia. 63, 90 and 125 mm operators)

TO ORDER: (for compatibility: see page 37)

- Add suffix **VI**

ORDERING EXAMPLES:

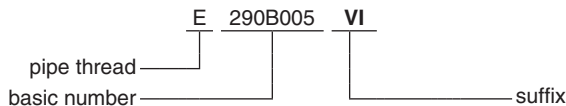

CONSTRUCTION 07

Adapter plate for NAMUR pad-mount pilot

- Adaptable on diameter Ø 63, 90 and 125 mm operators
- Stainless steel AISI 316L
- Solenoid pilot valves, series 551, 3/2 NC :
 - aluminium body, catalogue number SCG551A001 (www.asco.com)
 - St. steel body, AISI316L, catalogue number SCG551A409 (www.asco.com)

TO ORDER: (for compatibility: see page 37)

- Add suffix
 - stainless steel AISI 316L **AP3** (dia. 63 mm operator)
 - stainless steel AISI 316L **AP4** (dia. 90 and 125 mm operators)

ORDERING EXAMPLES:

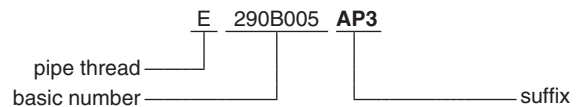

CONSTRUCTION 08

Oxygen service

- Special grease and cleaning
- Pressure limited to 15 bar/temperature limited to +60°C

TO ORDER: (for compatibility: see page 37)

- Add suffix **N**

ORDERING EXAMPLES:

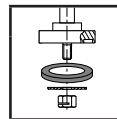
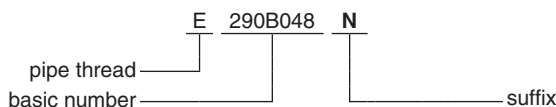

CONSTRUCTION 09

Vacuum applications up to 1,33 10⁻³ mbar

- FPM disc for use with medium vacuum

TO ORDER: (for compatibility: see page 37)

- Add suffix **VM**

ORDERING EXAMPLES:

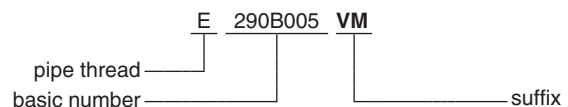

CONSTRUCTION 10

NET-INOX treatment

- Stainless steel valve body pickled in nitric hydrofluoric acid bath
- Treatment recommended for aggressive environments
- Standard on valves with CLAMP-type connections

TO ORDER: (for compatibility: see page 37)

- Add suffix **NI**

ORDERING EXAMPLES:

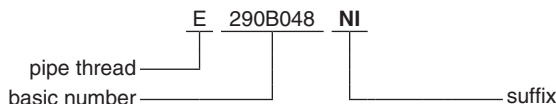

CONSTRUCTION 11

Conformity with Regulation (EC) 1935-2004

- The material of the wetted parts are listed in the chart of the Annex I of Regulation (EC) 1935/2004

TO ORDER: (for compatibility: see page 37)

- Add suffix **FB**

ORDERING EXAMPLES:

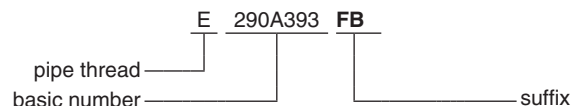

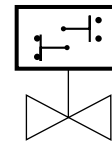

FEATURES

- The signaling box fits all series 290 (2/2) and 390 (3/2) valves with 50 mm (NC) and 63 to 125 mm (NC/NO) operators to indicate whether the valve is open or closed
- It is rotatable through 360° and equipped with two mechanical or inductive contacts
- The signaling box is supplied pre-installed and pre-adjusted on the valve. It can be delivered separately for on-site installation on any valve already in service
- The version with mechanical contacts can be used with up to max. 250 V AC and in magnetic field environments.

GENERAL / OPERATION

At both end-of-travel positions (open and closed) of the valve stem, cams on the signaling box plunger operate contacts which provide an electrical signal indicating that the end position is reached.

CONSTRUCTION

Body PA
Cover PA, transparent
Protection rating IP65
Unit can be rotated through 360° around the centreline of the valve operator (set screw)

ELECTRICAL CHARACTERISTICS

mechanical contacts	inductive contacts
Breaking capacity of contacts: • resistive circuit: 3,2 A at 250 V AC • inductive circuit: 1,8 A under 250 V AC (cos Ø= 0.8)	• 10 to 30 V DC power supply • load current 200 mA max. • built-in electrical protection

Electrical connection

mechanical contacts 1 terminal strip with 6 screw terminals
 inductive contacts 2 terminal strips with 2 screw terminals
Max. grip 2,5 mm²
Cable entry 1 cable gland (cable Ø 5-10 mm)

SPECIFICATIONS

operator	suffix ⁽¹⁾ signaling box supplied installed on valve	
	2 mechanical contacts	2 inductive contacts
Ø 50 mm (NC)	SM2	SI2
Ø 63, 90, 125 mm (NC-NO)		

⁽¹⁾ Add the appropriate suffix after the catalogue number of the selected valve, example:

- catalogue number of valve alone **E290B010**
- catalogue number of valve + pre-installed inductive contacts box = **E290B010 SI2** ;
The inductive contacts box is supplied installed on the valve and pre-adjusted.

NOTE - The signaling box can be supplied separately for on-site installation on any valve already in service (contact us).

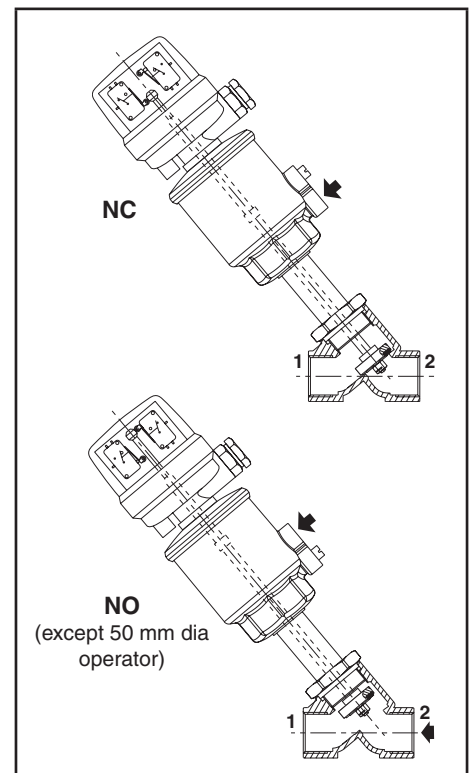

OPTIONS

- Other types of contacts: contact us

INSTALLATION

- The signaling box can be installed in any position
- Electrical connection:

mechanical contacts

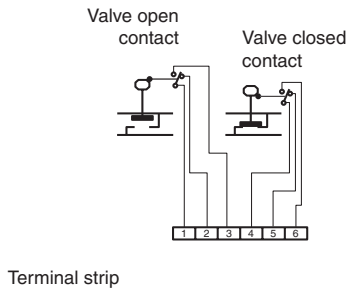

inductive contacts

(valve closed)

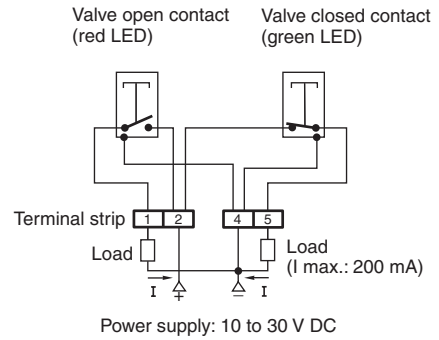

- Installation/maintenance instructions are included with each signaling box

DIMENSIONS (mm), WEIGHT (kg)

Weight of unit alone: 0,310

INSTALLATION SUR SERIES 290 & 390

with dia 50 (NC), 63, 90 or 125 mm operator

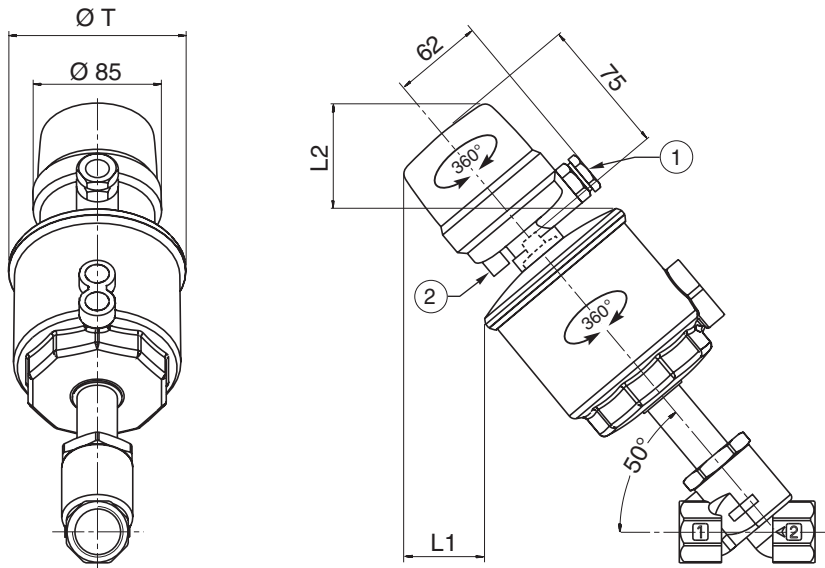

operator dia.	50 mm	63 mm	90 mm	125 mm
L1	53	46	35	32
L2	75	70	56	50
Ø T	65	85	118	156

- ① 1 cable gland (cable Ø 5-10 mm)
- ② Unit rotation lock set screw (orientable through 360°)

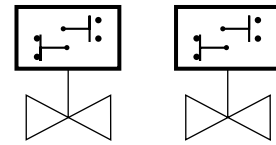

FEATURES

- The signaling unit fits all 290 (2/2) and 390 (3/2) valves with 32 mm/50 mm (NC), 63 to 125 mm (NC/NO) operators and electrically and visually indicates whether the valve is open or closed
- Size and shape adapted for easy valve installation
- Detectors held in place by lateral grooves
- Incorporated detectors for enhanced protection
- One standard detector support suitable for both reed switch and magneto-resistive (MR) "T"-type detectors

GENERAL / OPERATION

The magnet support of the compact signaling unit is attached to the stem of the valve and contains the permanent magnet. The extreme positions of the valve stem can therefore be detected by either the reed switch or the magneto-resistive detectors.

It is possible to install one or two detectors to monitor one or both extreme positions of a valve.

CONSTRUCTION

Support PA
Detector encapsulation PA + FV
Cable PUR, resistant to cutting oils (PVC = M12, IP69K)

CHARACTERISTICS

	Reed switch detector	Magneto-resistive detector
Max. breaking power	5 VA (AC) -5 W (DC)	3 W (DC)
Switching voltage	AC/DC: 5 to 120 V max.	10 to 30 V DC
stripped ends connector	AC: 5 to 50 V max. DC: 5 to 60 V max.	10 to 30 V DC
Max. switching current	100 mA	100 mA
Short-circuit protection	No	Yes
Reverse polarity protection	Yes (without LED function)	Yes
Overload protection	No	Yes
Wiring	-	PNP - NPN
Voltage drop	< 5 V	< 1,5 V (I = 50 mA) < 2,5 V (I = 100 mA)
Breakdown voltage	230 V DC	-
Contact resistance	max. 0,2 ohm	-
Insulation resistance	2.10 ⁸ ohm at 100 V	-
Max. leakage current	-	< 50 µA
Max. allowable overvoltage	-	32 V DC max. (100 ms)
Sensitivity	Min. 2,1 mTesla (21 Gauss)	Min. 2 mTesla (20 Gauss)
Response time		
opening	0,1 ms	110 µs
closing	0,6 ms	220 µs
Repeatability	< ± 0,2 mm	< 0,2 mm
Temperature range	-25°C to +70°C	-25°C to +85°C
Degree of protection	IP67	IP67 / IP69K
Protection class	Cable outlet, class II M8 + M12, class III	Class III
Approval	CE	CE (UL, cUL 2m + M8)
Signal indication	Yellow diode (LED) which lights up when contact is established	

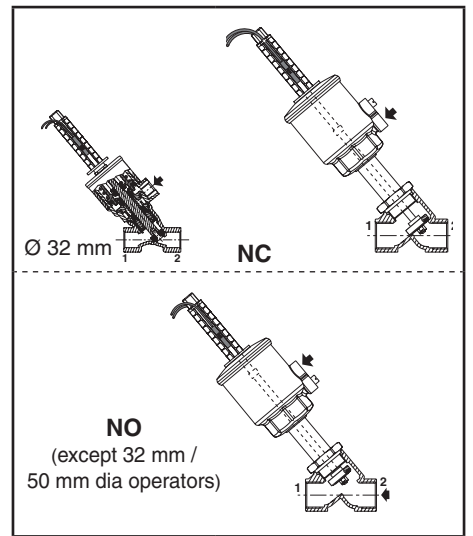
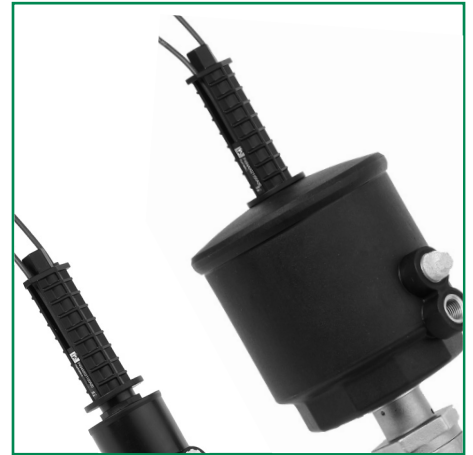

SPECIFICATIONS

1 SIGNALING SUPPORT

description	suffix
• Signaling support supplied installed on valve	SU ⁽¹⁾

2 MAGNETIC POSITION DETECTOR (Detectors are always delivered separately.)

description	IP	lead	catalogue number ^{(1) (2)}			
			reed switch detector	MR detector		
				PNP	NPN	
• stripped ends	2 wires	2 m	P494A0021300A00	-	-	
			5 m	P494A0021100A00	-	-
	3 wires	2 m	-	P494A0022300A00	P494A0022400A00	
		5 m	-	P494A0022100A00	-	
• 3-pin plug-in male connector and Ø M8	0,3 m	IP67	PUR	P494A0021500A00	-	-
				P494A0021600A00	-	-
	0,3 m	IP67	PUR	-	P494A0022600A00	P494A0022700A00
				P494A0021700A00	-	-
• 3-pin screw-type male connector, Ø M12	0,3 m	IP67	PUR	-	P494A0022800A00	-
				IP69K	PVC	-

⁽¹⁾ Add the suffix "SU" after the catalogue number of the selected valve.

Example: catalogue number of valve alone **E290A010** / catalogue number of valve + pre-installed signaling support **E290A010SU** + catalogue number of detector and required quantity

⁽²⁾ Each catalogue number corresponds to one single detector.

INSTALLATION

- Polarised magneto-resistive (MR) detector with output protected against possible short-circuits on load at an output current lower than or equal to 0,1 A. In case of inductive load, use a diode in parallel with the load
- Installation/maintenance instructions are supplied with each compact signaling unit

ACCESSORIES

<ul style="list-style-type: none"> • PVC extension cord, length 5 m, 3-wire conductors 0.25 mm² with 1 screw-type female M8 connector (other end plain)⁽¹⁾, catalogue number P4994406200N001 	
<ul style="list-style-type: none"> • PVC extension cord, length 5 m, 3-wire conductors 0.25 mm² with 1 screw-type female M12 connector (other end plain)⁽¹⁾, catalogue number P4994406210N001 	
<ul style="list-style-type: none"> • Straight 3-pin female connector Ø M8, IP67, catalogue number P4994406220N001 	
<ul style="list-style-type: none"> • Right angle 3-pin female connector Ø M8, orientable 90° x 90°, IP67, catalogue number P4994406230N001 	
<ul style="list-style-type: none"> • Block of memorizing position of adjustment detector, catalogue number P4994406160N001 	

⁽¹⁾ Detector connection:
Magneto-resistive type: brown wire = +, blue wire = -, black wire = load

DIMENSIONS (mm), WEIGHT (kg)

Weight of signaling support: 0,25

Weight of one single detector: 0,007 to 0,050 depending on connector configuration and cable length

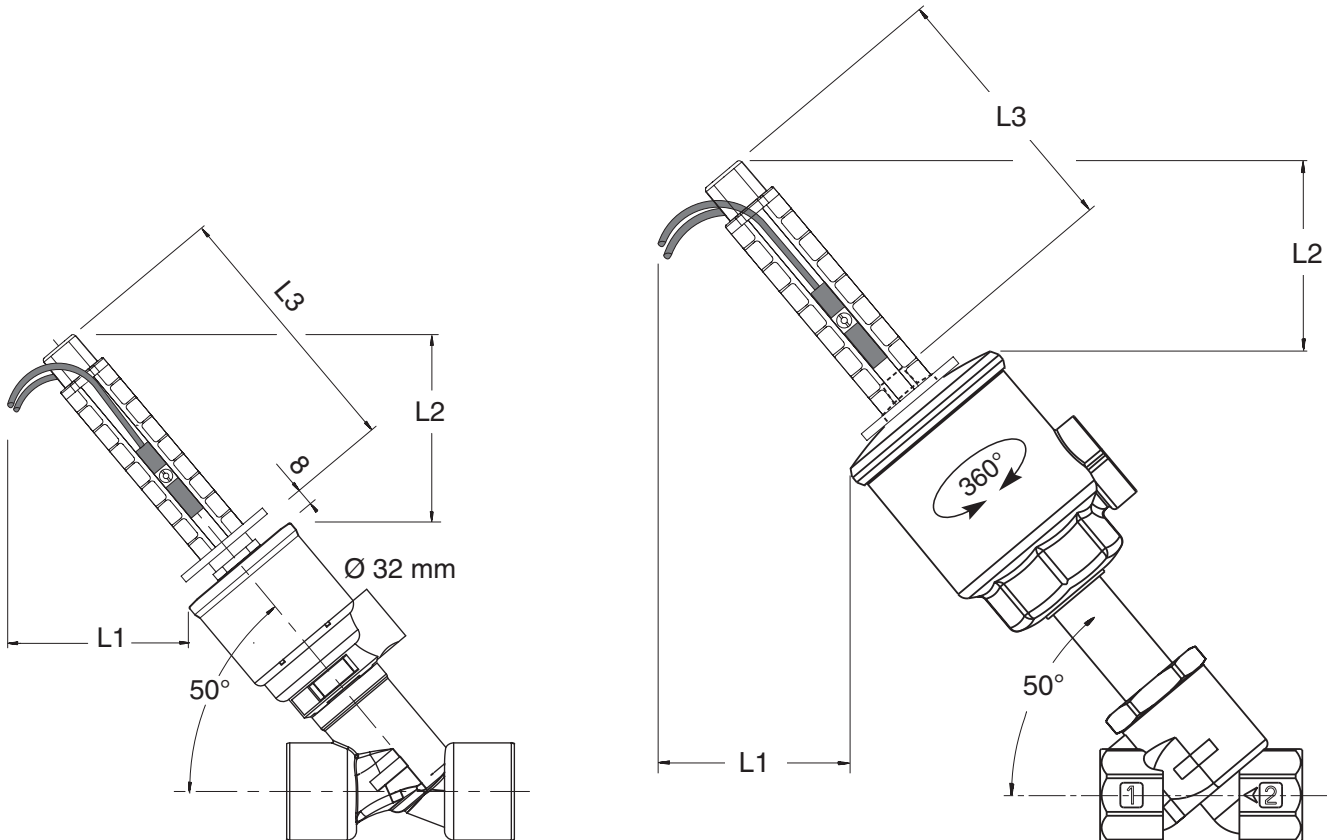

	operator dia.				
	32 mm (NC)	50 mm (NC)	63 mm	90 mm	125 mm
L1	60	67	60	47	33
L2	66	47	42	38	19
L3	86	70	70	70	70



CONSTRUCTION 07

Adapter plate for NAMUR pad-mount pilot

- Adaptable on diameter Ø 63, 90 and 125 mm operators
- Stainless steel AISI 316L
- Solenoid pilot valves, series 551, 3/2 NC:
 - aluminium body, catalogue number **SCG551A001** (www.asco.com)
 - St. steel body, AISI316L, catalogue number **SCG551A409** (www.asco.com)

TO ORDER: (for compatibility: see page 43)

- Add suffix
 - stainless steel AISI 316L **AP3** (dia. 63 mm operator)
 - stainless steel AISI 316L **AP4** (dia. 90 and 125 mm operators)

ORDERING EXAMPLES:

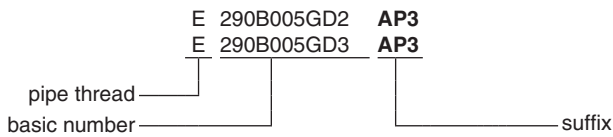

CONSTRUCTION 08

Oxygen service

- Special grease and cleaning
- **Pressure limited to 15 bar/temperature limited to +60°C**

TO ORDER: (for compatibility: see page 43)

- Add suffix **N**

ORDERING EXAMPLES:

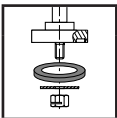
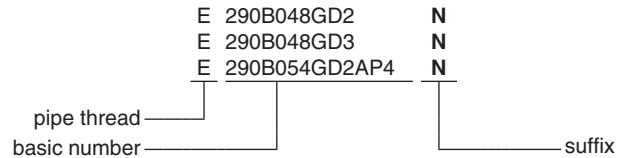

CONSTRUCTION 09

Vacuum applications up to 1,33 10⁻³ mbar

- FPM disc for use with medium vacuum

TO ORDER: (for compatibility: see page 43)

- Add suffix **VM**

ORDERING EXAMPLES:

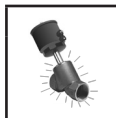
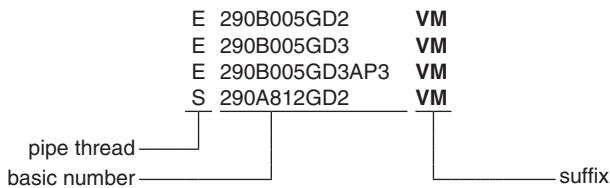

CONSTRUCTION 10

NET-INOX treatment

- Stainless steel valve body pickled in nitric hydrofluoric acid bath
- Treatment recommended for aggressive environments
- Standard on valves with CLAMP-type connections

TO ORDER: (for compatibility: see page 43)

- Add suffix **NI**

ORDERING EXAMPLES:

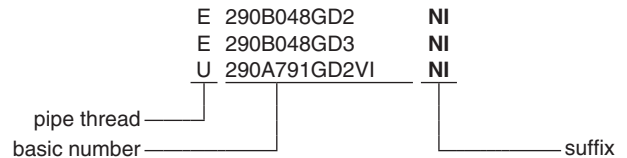

CONSTRUCTION 11

Conformity with Regulation (EC) 1935-2004

- The material of the wetted parts are listed in the chart of the Annex I of Regulation (EC) 1935/2004

TO ORDER: (for compatibility: see page 43)

- Add suffix **FB**

ORDERING EXAMPLES:

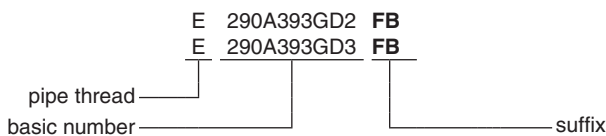

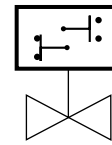

FEATURES

- The signaling box fits all series 290 (2/2) and 390 (3/2) valves with 50 mm (NC) and 63 to 125 mm (NC/NO) operators to indicate whether the valve is open or closed
- The version with 2 intrinsically safe inductive NAMUR contacts is designed for use in potentially explosive atmospheres to ATEX-Directive 2014/34/EU
- Compliance with the Essential Health and Safety Requirements has been assured by compliance with the International and European Standards EN 60079-0, EN 60079-11 and EN 60076-26
- The signaling box is supplied pre-installed and pre-adjusted on the valve. It is rotatable through 360°
- The signaling box complies with the EMC Directive 2014/30/EU

OPERATION

At both end-of-travel positions (open and closed) of the valve stem, cams on the signaling box plunger operate contacts which provide an electrical signal indicating that the end position is reached.

GENERAL

Ambient temperature range -10°C to +60°C

CONSTRUCTION

Body, cover PA
Degree of protection IP66
Unit can be rotated through 360° around the centreline of the valve operator (set screw)

ELECTRICAL CHARACTERISTICS

intrinsically safe inductive NAMUR contacts

The protection rating of the installed signaling box depends on the type of selected valve (see page 1).

Contact characteristics:

- Power supply: 8,2 V DC
- Switching frequency: 800 Hz

Protection rating of contacts:

- II 1 G Ex ia IIB T6 Ga
- II 2 G Ex ia IIB T6 Gb
- II 1 D Ex ia IIIC T90°C Da

• EC type examination certificate no.:
BVS 04 ATEX E153
PTB 01 ATEX 2191

• Recommended interfaces:
galvanic barrier
Pepperl & Fuchs type KFA6-SR2-EX1.W
MTL instruments type MTL5011B
ZENER barrier
MTL instruments type MTL7742

safety parameters				
U _i	I _i	P _i	L _i	C _i
15 V	50 mA	120 mW	110 μH	80 nF

Electrical connection

intrinsically safe inductive NAMUR contacts 2 terminal strips with 5 screw terminals
Max. grip 2,5 mm²
Cable entry 1 cable gland (cable Ø 5-10 mm)

SPECIFICATIONS

operator	suffix ⁽¹⁾ signaling box supplied installed on valve 2 intrinsically safe inductive contacts
dia. 50 mm (NC), dia. 63, 90, 125 mm (NC-NO)	SH2

- ⁽¹⁾ Add the appropriate suffix after the catalogue number of the selected valve, example:
- catalogue number of valve alone **E290B010**
- catalogue number of valve + pre-installed intrinsically safe inductive contacts box = **E290B010 SH2**

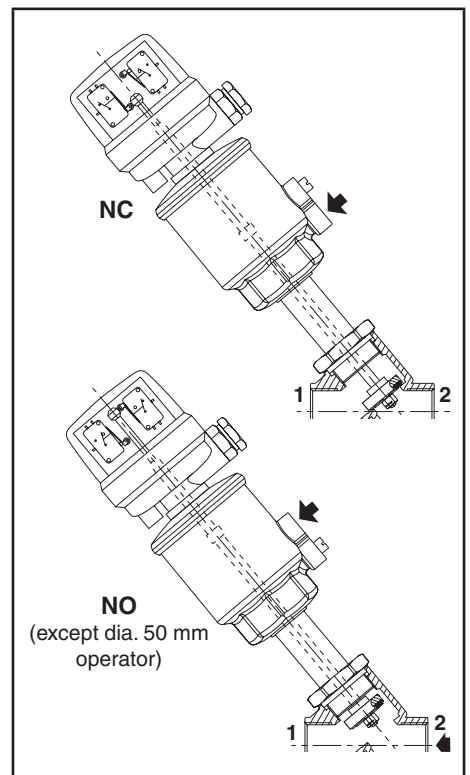

OPTIONS

- Other types of contacts: contact us

INSTALLATION

- The signaling box can be installed in any position
- Electrical connection:

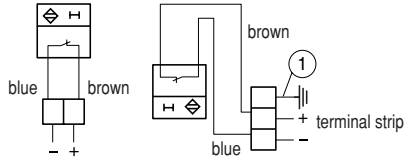

① Electrical continuity terminal

- Installation/maintenance instructions are included with each signaling box

DIMENSIONS (mm), WEIGHT (kg)

Weight of unit alone: 0,310

INSTALLATION ON SERIES 290 & 390

with dia 50 (NC), 63, 90 or 125 mm operator

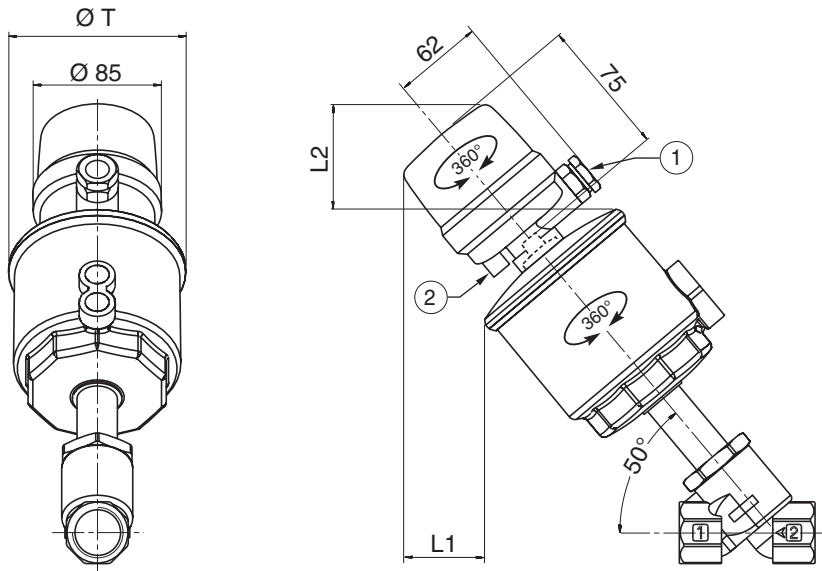

operator dia.	50 mm	63 mm	90 mm	125 mm
L1	53	46	35	32
L2	75	70	56	50
Ø T	65	85	118	156

- ① 1 cable gland (cable Ø 5-10 mm)
- ② Unit rotation lock set screw (orientable through 360°)

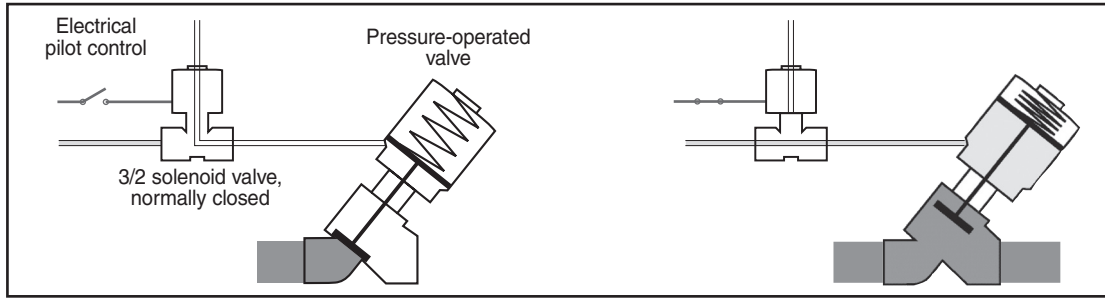

Pressure operated valves are piloted by a 3/2 solenoid valve either directly mounted on the valve or remotely connected.

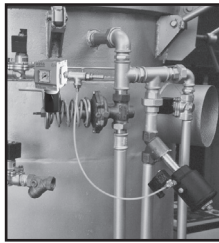

DIRECT OPERATED

- Short response times
- Easy on-site testing with the solenoid valve's manual override.
- Possibility to use the fluid (air, water) of the supply line as pilot fluid.

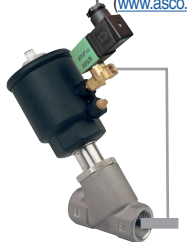

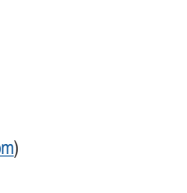
Electrical pilot control	3 to 11 W per valve	 <p>page 49 www.asco.com</p>	 <p>page 51 www.asco.com</p>
Compressed air		 <p>www.asco.com</p>	 <p>page 37 www.asco.com</p>

Namur interface







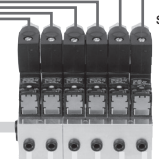

REMOTE OPERATED

Solution 1: Solenoid pilot valves mounted on joinable subbases according to CNOMO standard with integrated instant fitting pneumatic connections or on manifolds.

Solution 2: Distribution islands with two 3/2 solenoid valves per module, up to 32 valves can be piloted with a series 501 island.

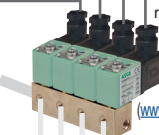
- Centralised electrical connection
- Integrated plug-in type valve power connection
- Modifiable connections thanks to cartridge-type instant fittings
- Compatible with the following fieldbuses:



Electrical pilot control	<p>Solution 1 1 W per valve</p>  <p>subbases CNOMO page 21⁽¹⁾ www.asco.com</p>	   
or fieldbus control	<p>4 W per valve</p>  <p>manifolds page 31⁽¹⁾ www.asco.com</p>	
Compressed air	<p>Solution 2 0,75 W per valve</p>  <p>page 1⁽²⁾ www.asco.com</p>	 

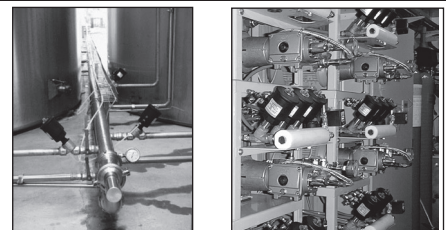

See sections: ⁽¹⁾ Solenoid Valves (3/2)
⁽²⁾ Fieldbus Electronics

The valve islands and/or solenoid pilot valves can be grouped together in one place.
Cabinet installation for use in "aggressive" environments.
Reduced electrical wiring. Low power consumption.

All leaflets are available on: www.asco.com



SOLENOID PILOT VALVES

with 290/390 valves, 32, 50 & 63 mm operators
direct operated
1/8

NC

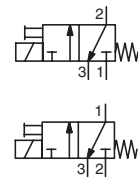

3/2
Series
189/banjo
356

FEATURES

- Compact design and low weight enabling easy installation on all series 290 & 390 valves with 32, 50 & 63 mm operators
- Manual operator allows an easy installation
- AC/DC interchangeability of the solenoid without disassembly of the valve
- Simple installation (supply port, solenoid valve body, coil and connector rotatable through 360°), built-in exhaust regulator (pilot valve series 189/banjo coupling)
- Compliance with UL and CSA standards (pilot valve series 356 coupling)
- The solenoid valves satisfy all relevant EU Directives

GENERAL

Differential pressure See «SPECIFICATIONS» [1 bar = 100 kPa]
Maximum viscosity 40 cSt (mm²/s)
Response time See page 7 (www.asco.com)

pilot (series)	fluids (*)	temperature range (TS)	seal materials (*)
189 banjo	filtered air	-10°C to +60°C	NBR (nitrile)
356	filtered air and water		FPM (fluoroelastomer)

MATERIALS IN CONTACT WITH FLUID

(*) Ensure that the compatibility of the fluids in contact with the materials is verified

	Banjo pilot 189	Pilot 356
Body	PA, glass fibre reinforced	Brass or stainless steel AISI 316
Core tube	Brass	Stainless steel
Core and plugnut	Stainless steel	Stainless steel
Springs	Stainless steel	Stainless steel
Seats	PA + Stainless steel	Brass or stainless steel
Seals	NBR	FPM
Shading coil	Copper	Copper

ELECTRICAL CHARACTERISTICS

Coil insulation class F
Connector Spade plug (cable Ø 6-8 mm)
Connector specification DIN 43650, 11 mm, industry standard B
Electrical safety IEC 335
Electrical enclosure protection Moulded IP65 (EN 60529)
Standard voltages DC (=) : 24V - 48V
(Other voltages and 60 Hz on request) AC (~) : 24V - 48V - 115V - 230V / 50 Hz

prefix option	power ratings				operator ambient temperature range (TS) (C°)	replacement coil		type ⁽¹⁾
	inrush ~	holding ~	hot/cold =			~	=	
	(VA)	(VA)	(W)	(W)		230 V/50 Hz	24 V DC	
-	6	3,5	2,5	2,5 / 3	-10 to +60	400127-097	400904-542	01
SC	12	6	4	5 / 6,9	-10 to +60	400127-197	400127-142	02

⁽¹⁾ Refer to the dimensional drawings on the following page.

SPECIFICATIONS

pipe size	orifice size		flow coefficient Kv				operating pressure differential (bar)						power coil (W)		catalogue number with maintained manual operator	
							max. (PS)									
							min. ⁽⁴⁾		air (*)		water (*)					
G	2↔1 (mm)	1-2→3 (mm)	2↔1 (m ³ /h)	1-2→3 (l/min)	2↔1 (m ³ /h)	1-2→3 (l/min)	~	=	~	=	~	=	~	=	~/=	
NC - Normally closed, series 189 banjo pilot																
1/8 ⁽²⁾	1,2	1,2	0,03	0,5	0,04	0,7	0	10	10	-	-	2,5	3	18900032		
NC - Normally closed, series 189 banjo pilot with built-in exhaust regulator																
1/8 ⁽²⁾⁽⁵⁾	1,2	1,2	0,03	0,5	0,04	0,7	0	10	10	-	-	2,5	3	18900047		
NC - Normally closed, series 356 pilot, brass body																
1/8 ⁽²⁾	1,6	1,2	0,08	1,33	0,05	0,8	0	10	10	10	10	4	6,9	SCG356B053VMS ⁽³⁾		
NC - Normally closed, series 356 pilot, stainless steel body																
1/8 ⁽²⁾	1,6	1,2	0,08	1,33	0,05	0,8	0	10	10	10	10	4	6,9	SCG356B058VMS ⁽³⁾		

- ⁽²⁾ Pipe size:
- Port 1: O.D. 4 mm instant fitting (189 banjo) / 1/8 (series 356)
- Port 2: 1/8
- Port 3 (exhaust): M5

⁽³⁾ Solenoid valve with 1/8 adapter.

⁽⁴⁾ Refer to leaflets on series 290/390 valves which show the minimum pilot pressure for each version of the product.

⁽⁵⁾ Exhaust regulator integrated at port 3, M5.

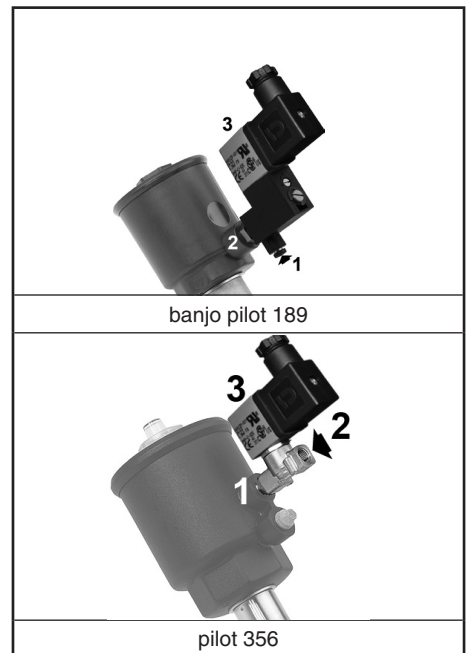

00056GB-2017/R01 Availability, design and specifications are subject to change without notice. All rights reserved.

OPTIONS

- Explosionproof enclosures for use in zones 1/21-2/22, categories 2-3 to ATEX Directive 2014/34/EU (www.asco.com)
- Connector with visual indication and peak voltage suppression or with cable length of 2 m (www.asco.com)
- M5 exhaust regulator to fit port 3, catalogue number: **34600380**

INSTALLATION

- The solenoid valves can be mounted in any position without affecting operation
- Pipe connection identifier is G = G (ISO 228/1)
- Installation/maintenance instructions are included with each valve

ORDERING EXAMPLES:

18900032	230V / 50 Hz
SC G356B053 VMS	24V / DC
SC G356B053 VMS	230V / 50 Hz
catalogue number _____	_____ voltage

DIMENSIONS (mm), WEIGHT



TYPE 01
Pilot 189/banjo
Epoxy moulded
IEC 335 / DIN 43650
IP65

18900032 - 18900047



TYPE 02
Prefix "SC" Solenoid
Pilot 356
Epoxy moulded
IEC 335 / DIN 43650 / IP65

SCG356B053VMS - SCG356B058VMS

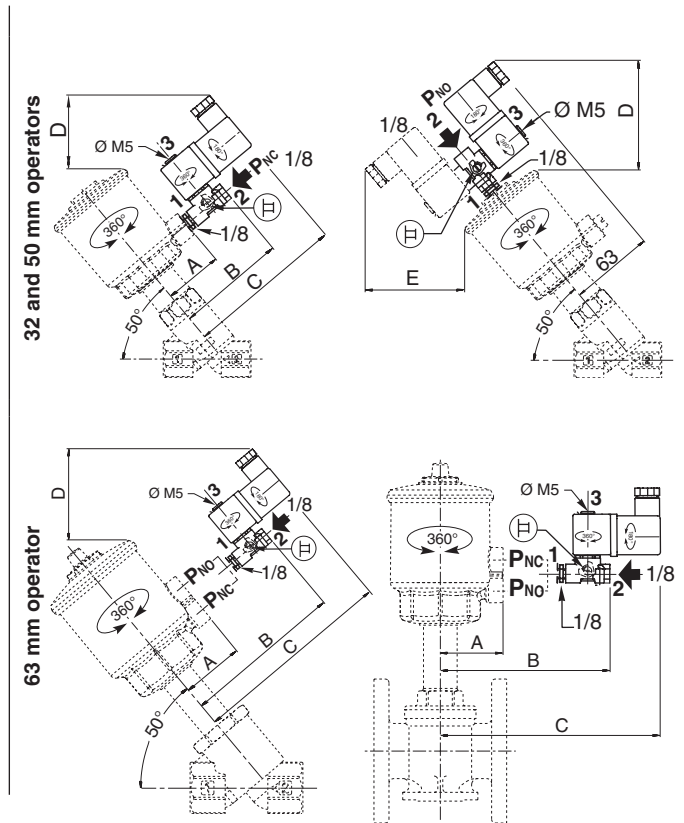
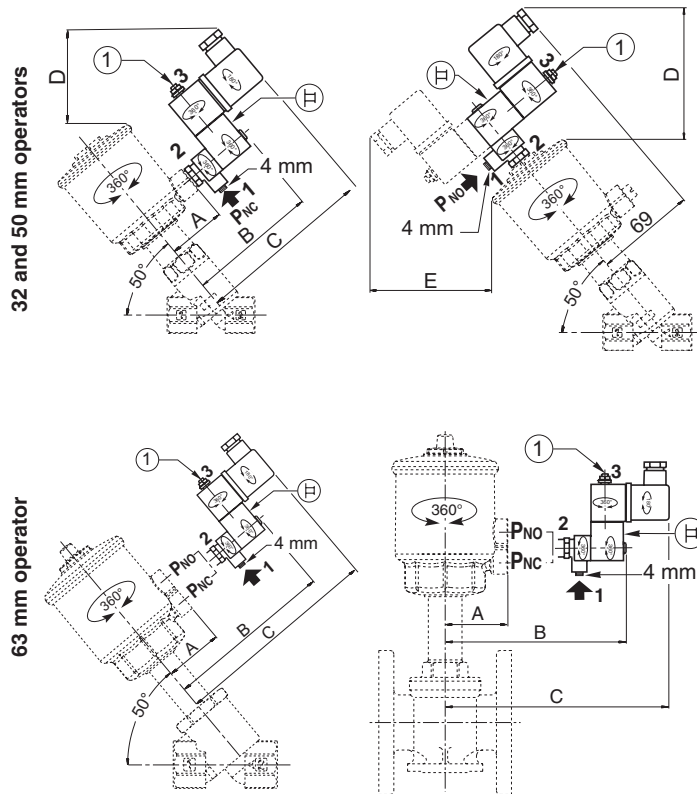

type	prefix option	pilot	operator diameter	A	B	C	D		E	pilot inlet port		weight ⁽¹⁾
							NC	NO		NC	NO	
01	-	189/banjo series	32 mm	27	78,5	113,5	79	102	85	P _{NC}	P _{NO}	0,175
			50 mm	43	93	149	67	83	74			
			63 mm	50,5	100	156	53	62	-			
02	SC	356 series	32 mm	27	68	102	65	90	85	P _{NC}	P _{NO}	0,165
			50 mm	43	84	118	56	80	74			
			63 mm	50,5	91,5	125,5	41	59	-			

① Exhaust regulator location

⁽¹⁾ including adapter connection (series 356), coil and connector.



SOLENOID PILOT VALVES

with 290/390 valves, with 90 & 125 mm operators
direct operated
1/4

NC

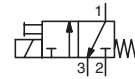

3/2
Series
314
356

FEATURES

- Compact design and low weight enabling easy installation on all series 290 & 390 valves with 90 & 125 mm operators
- Manual operator allows an easy installation
- Pilot 356: AC/DC interchangeability of the solenoid without disassembly of the valve
- The solenoid valves satisfy all relevant EU Directives

GENERAL

Max. pilot pressure 0 to 10 bar [1 bar = 100 kPa]
Maximum viscosity Pilot 314: 65 cSt (mm²/s) / Pilot 356: 40 cSt
Response time See page 7 (www.asco.com)

pilot (series)	fluids (*)	temperature range (TS)	seal materials (*)
314	filtered air and water	-10°C to +60°C	314/356 pilots: NBR (nitrile)
356			314 pilot: FPM (fluoroelastomer)

MATERIALS IN CONTACT WITH FLUID

(*) Ensure that the compatibility of the fluids in contact with the materials is verified

	Pilot 314	Pilot 356
Body	Brass or st. steel AISI 304	Brass or st. steel AISI 316
Core tube	Stainless steel	Stainless steel
Core and plugnut	Stainless steel	Stainless steel
Springs	Stainless steel	Stainless steel
Seats	Brass	Brass
Seals / Disc	NBR	FPM
Upper disc	FPM	-
Shading coil	Copper or silver	Copper

ELECTRICAL CHARACTERISTICS

Coil insulation class F
Connector Spade plug (cable Ø 6-10 mm)
Connector specification ISO 4400 / EN 175301-803, form A
Electrical safety IEC 335
Electrical enclosure protection Moulded IP65 (EN 60529)
Standard voltages DC (=) : 24V - 48V
 (Other voltages and 60 Hz on request) AC (-) : 24V - 48V - 115V - 230V / 50 Hz

prefix option	power ratings			operator ambient temperature range (TS) (C°)	replacement coil		type ⁽¹⁾
	inrush	holding	hot/cold		~	=	
	(VA)	(VA) (W)	(W)		230 V/50 Hz	24 V DC	
-	50	25 10,1	8,5 / 11,6	-10 to +60	238613-059	238713-006	01
SC	15	7 5	5 / 6,9	-10 to +60	400727-117	400727-185	02

⁽¹⁾ Refer to the dimensional drawings on the following page.

SPECIFICATIONS (314 Series)

pipe size	orifice size	flow coefficient Kv		operating pressure differential (bar) max. (PS)						power coil (W)	thread type	dimensions / type ⁽¹⁾	15-DIGIT PRODUCT CODE											
		2 → 1	1 → 3	min. ⁽³⁾			max. (PS)						brass ⁽²⁾	stainless steel ⁽²⁾	voltage code									
		(mm)	(m ³ /h)(l/min)	(m ³ /h)(l/min)	air (*)	water (*)	oil	~	=						-	-	24 V/50 Hz	48 V/50 Hz	115 V/50 Hz	230 V/50 Hz	24 V/DC	48 V/DC		
1/4	3,2	0,22	3,7	0,17	2,8	0	10	6	10	6	-	-	10,1	11,6	G*	01	E314K141S1N01	E314K140S1N01	FL	FR	FT	F8	F1	F9

SPECIFICATIONS (356 Series)

pipe size	orifice size	flow coefficient Kv		operating pressure differential (bar) max. (PS)						power coil (W)	catalogue number ⁽²⁾				
		2 → 1	1 → 3	min. ⁽³⁾			max. (PS)				brass body	stainless steel body			
		(mm)	(mm)	(m ³ /h)(l/min)	(m ³ /h)(l/min)	air (*)	water (*)	~	=				~	=	
G	(mm)	(mm)	(m ³ /h)(l/min)	(m ³ /h)(l/min)	~	=	~	=	~	=	~	=	~/=	~/=	
1/4	1,6	1,2	0,08	1,33	0,05	0,8	0	10	10	10	10	5	6,9	SCG356B467VMS	SCG356B473VMS

⁽²⁾ Solenoid valve with 1/4 adapter.

⁽³⁾ Refer to leaflets on series 290/390 valves which show the minimum pilot pressure for each version of the product.

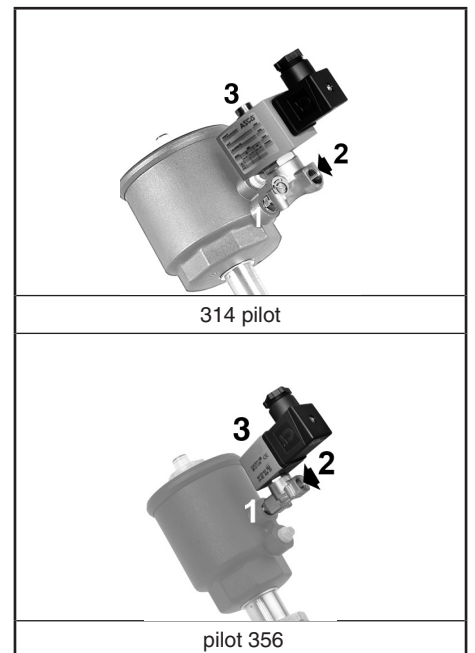

00198GB-2017/R01 Availability, design and specifications are subject to change without notice. All rights reserved.

OPTIONS

- Explosionproof enclosures for use in zones 1/21-2/22, categories 2-3 to ATEX Directive 2014/34/EU (www.asco.com)
- flow control device to fit port 3 (to increase air-operated pilot depressurization time):
M5, catalogue number: **34600380** / 1/8, catalogue number: **34600107**
- Connector with visual indication and peak voltage suppression or with cable length of 2 m (www.asco.com)

INSTALLATION

- The solenoid valves can be mounted in any position without affecting operation
- Pipe connection 1/4 (G*) has standard combination thread according to ISO 228/1 and ISO 7/1. Pipe connection G 1/8 or G 1/4 has standard thread according to ISO 228/1
- Installation/maintenance instructions are included with each valve

SPARE PARTS KIT

catalogue number	spare parts kit no.	
	~	=
E314K141S1N01	M200071N00	M200067N00
E314K140S1N01	M200073N00	M200069N00

ORDERING EXAMPLES:

E314K141S1N01 F8	
SC G 356 B 467 VMS	24V / DC voltage
catalogue number	

ORDERING EXAMPLES KITS:

M200071N00
basic number

DIMENSIONS (mm), WEIGHT



TYPE 01

Electrical interface "S1" (314 pilot)
Epoxy moulded
IEC 335 / ISO 4400
IP65

E314K140S1N01/141S1N01

90 and 125 mm operators

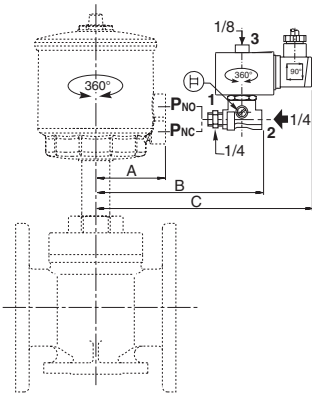
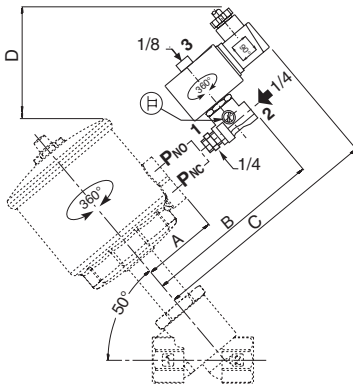

TYPE 02

Prefix "SC" Solenoid (pilot 356)
Epoxy moulded
IEC 335 / ISO 4400
IP65

SCG356B467VMS/473VMS

90 and 125 mm operators

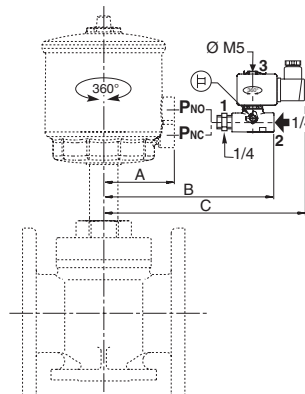
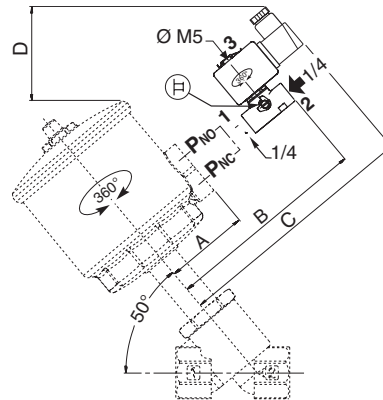

type	prefix option	pilot	operator diameter	A	B	C	D		pilot inlet		weight ⁽¹⁾
							NC	NO	NC	NO	
01	-	314 series	90 mm	67	128	169	72	91	P _{NC}	P _{NO}	0,610
			125 mm	86	147	188	123	142			
02	SC	356 series	90 mm	67	119	150	46	65	P _{NC}	P _{NO}	0,253
			125 mm	86	138	169	97	116			

⁽¹⁾ including adapter connection, coil and connector.



VALVES

pressure operated
stainless steel body
with threaded ports PN40, 1/2 to 2

NC

NO

2/2
Series
E298

FEATURES

- Ruggedly built valve, particularly recommended for use with steam, superheated water, corrosive fluids
- High-performance, maintenance-free stuffing box, resistant to thermal shock
- Pressure can be applied to any port as needed by the process
- Anti-waterhammer design (fluid entry at orifice 1), recommended for use with liquids
- Vacuum operation up to 10^{-2} mbar (PTFE and PEEK discs)
- Optical position indicator as standard
- Autoclavable valve for use at high ambient temperatures (up to 180°C)
- The valves satisfy Pressure Equipment Directive 2014/64/EU
- The valves in conformity with IEC 61508 Standard (2010 route 2_H version) certified with integrity levels: SIL 2 for HFT = 0



GENERAL

Differential pressure	0 to 40 bar [1 bar =100 kPa]
Maximum allowable pressure	40 bar (within the specified limits, see diagram I)
Maximum back pressure	40 bar / 20 bar for PEEK sealing
Ambient temperature range	-20°C to +180°C [Option: -55°C to +70°C]
Maximum viscosity	5000 cSt (mm ² /s)
Pilot fluid	Air
Max. pilot pressure	10 bar
Min. pilot pressure	See graphs below

fluids (*)	temperature range	disc seal (*)
DN 15-20-25: air and gas groups 1 & 2 DN 32-40-50: air and gas group 2 all DN: water, oil, liquids groups 1 & 2 and steam	-10°C to +233°C	PEEK
	-10°C to +250°C	metal-to-metal
	-10°C to +180°C	PTFE

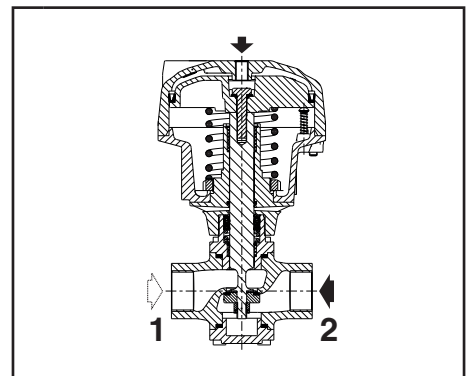
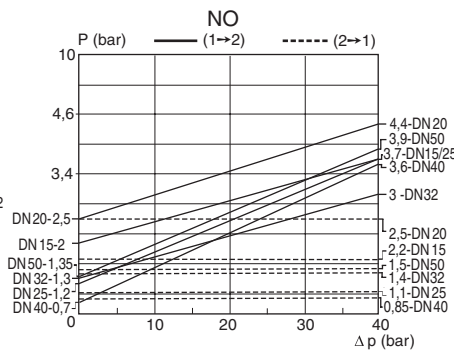
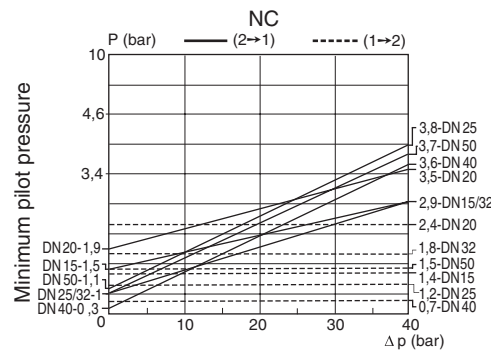

NC function

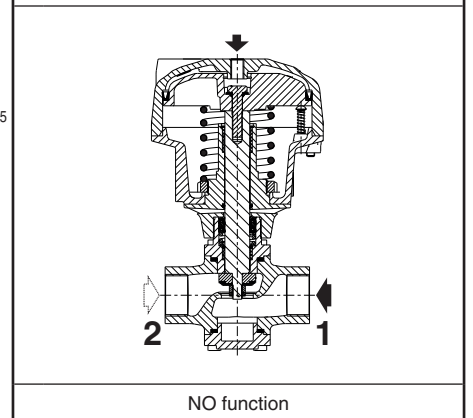

NO function

SPECIFICATIONS

Body connection	Threaded port, BSP DIN ISO 228/1 & ISO 7/1 NPTF ANSI B1.20.3
------------------------	---

GENERAL

MATERIALS IN CONTACT WITH FLUID	
(*) Ensure that the compatibility of the fluids in contact with the materials is verified	
Body and plug	304 stainless steel
Stuffing box housing	304 stainless steel
Stem, disc	431 stainless steel
Stuffing box packing	PTFE chevrons
Disc seals	PEEK or PTFE or Stainless steel
Valve body seal	PTFE

OTHER MATERIALS

Operator	Aluminium, nickel plated
Screws	Galvanized steel

(*) Ensure that the compatibility of the fluids in contact with the materials is verified.

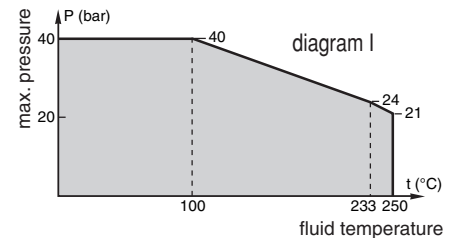

01188GB-2017/R01
Availability, design and specifications are subject to change without notice. All rights reserved.

OPTIONS

Low temperature (media and ambient temperature), PTFE disc seal (-55°C to +70°C), see "15-DIGIT PRODUCT CODE" (*) ⁽¹⁾
Oxygen service, max. fluid pressure 15 bar, max. fluid temperature 150°C, PTFE disc, see "15-DIGIT PRODUCT CODE"
Signalling box, see "15-DIGIT PRODUCT CODE": - Dual mechanical contacts or dual inductive contacts (PNP 3 wires) - Dual inductive contacts ATEX Ex ia (NAMUR 2 wires) - Dual mechanical contact ATEX Ex d IIC T6 (Crouzet contacts type 83101-I-W1, ambient temperature -20°C to +80°C) - Dual mechanical contact ATEX Ex d IIC T6 (Honeywell contact type 1HS1, ambient temperature -55°C to +70°C). Use for low temperature option
For use in explosive atmospheres, zones 1/21-2/22, categories 2-3 to ATEX Directive 2014/34/EU: Ex IIC 2GD c x°C (Tx)
CUTR Certification (EAC), see "15-DIGIT PRODUCT CODE"
Valve seat leakage class VI as defined by FCI-2 ANSI B16.104 or Class A or B following EN 12266-1, contact us
Manual override on the top of the actuator (Manual safety device), contact us
Other flange types are available on request
Re-buildable valve program; rebuild services, contact us

(*) Ensure that the compatibility of the fluids in contact with the materials is verified.

⁽¹⁾ The minimum ambient temperature of the valve is determined by the limitations of minimum temperature indicated.

SPECIFICATIONS

piping (ISO 6708)		orifice size	flow coefficient Kv				pilot pressure (bar)		operating pressure differential (bar)	operator diameter (mm)	catalogue number		
pipe size	DN		1 → 2		2 → 1		min.	max.			disc sealing		
(G*)		(mm)	(m³/h)	(l/min)	(m³/h)	(l/min)				PTFE	PEEK	metal-to-metal	
NC - Normally closed													
1/2	15	15	4,4	73	5	83	*	10	40	80	E298B0370TA0000	E298B0370VA0000	E298B0370EA0000
3/4	20	20	7,7	128	8,5	142	*	10	40	100	E298B04D0TA0000	E298B04D0VA0000	E298B04D0EA0000
1	25	25	11,5	192	12	200	*	10	40	100	E298B05D0TA0000	E298B05D0VA0000	E298B05D0EA0000
1 1/4	32	32	18	300	18	300	*	10	40	150	E298B06K0TA0000	E298B06K0VA0000	E298B06K0EA0000
1 1/2	40	40	29	483	29	483	*	10	40	150	E298B07K0TA0000	E298B07K0VA0000	E298B07K0EA0000
2	50	50	57	950	57	950	*	10	40	200	E298B08M0TA0000	E298B08M0VA0000	E298B08M0EA0000
NO - Normally open													
1/2	15	15	3,5	58	3,5	58	*	10	40	80	E298B1370TA0000	E298B1370VA0000	E298B1370EA0000
3/4	20	20	7,2	120	7	117	*	10	40	100	E298B14D0TA0000	E298B14D0VA0000	E298B14D0EA0000
1	25	25	11	183	11	183	*	10	40	100	E298B15D0TA0000	E298B15D0VA0000	E298B15D0EA0000
1 1/4	32	32	18	300	15	250	*	10	40	150	E298B16K0TA0000	E298B16K0VA0000	E298B16K0EA0000
1 1/2	40	40	28,2	470	28,2	470	*	10	40	150	E298B17K0TA0000	E298B17K0VA0000	E298B17K0EA0000
2	50	50	53	883	53	883	*	10	40	200	E298B18M0TA0000	E298B18M0VA0000	E298B18M0EA0000

* Minimum pilot pressure varies with differential pressure. See piloting chart preceding page.

HOW TO ORDER

[Configurator - CAD Files](#)

15-DIGIT PRODUCT CODE

E 298 B 0 3 7 0 V A00 00

Connection

E = ISO 228/1 & ISO 7/1
(combination thread, G*)
8 = NPTF (ANSI B1.20.3)

Product series

298

Revision letter

B = New Stuffing Box and
Disc Materials

Function

0 = Normally closed
1 = Normally open

Diameter (mm)

3 = 15 mm
4 = 20 mm
5 = 25 mm
6 = 32 mm
7 = 40 mm
8 = 50 mm

Operator Dia. - Piloting Connection Dia.

7 = Ø80 mm - G 1/8
8 = Ø80 mm - NPT 1/8 ⁽¹⁾
D = Ø100 mm - G 1/8
E = Ø100 mm - NPT 1/8 ⁽¹⁾
K = Ø150 mm - G 1/4
L = Ø150 mm - NPT 1/4 ⁽¹⁾
M = Ø200 mm - G 1/4
N = Ø200 mm - NPT 1/4 ⁽¹⁾

⁽¹⁾ Connection = 8 [NPTF (ANSI B1.20.3)]

Options

A00 = Without
AT1 = ATEX zones 1/21
AT2 = ATEX zones 2/22
LTP = PTFE disc for low temperature (-55°C to +70°C)
MC2 = Dual mechanical Contacts
AD2 = Dual position Contact ATEX Ex d
1S2 = Dual position Contact NAMUR ATEX Ex i
1C2 = Dual inductive contacts PNP 3 wires
02S = PTFE disc for Oxygen service
124 = CUTR Certification
A24 = CUTR Certification for ATEX 1/21
LT1 = AT1 + LTP
LT2 = AT2 + LTP

Disc Seal Material

T = PTFE
E = Metal-to-metal (stainless steel)
V = PEEK

SPARE PARTS KITS CODE (*)

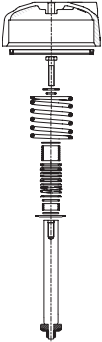
		PTFE disc seal	PEEK disc version
	DN 15 NC	M29852671700100	M29852671400100
	DN 20 NC	M29852671700400	M29852671400400
	DN 25 NC	M29852671700700	M29852671400700
	DN 32 NC	M29852671701000	M29852671401000
	DN 40 NC	M29852671701300	M29852671401300
	DN 50 NC	M29852671701600	M29852671401600
	DN 15 NO	M29852671700200	M29852671400200
	DN 20 NO	M29852671700500	M29852671400500
	DN 25 NO	M29852671700800	M29852671400800
	DN 32 NO	M29852671701100	M29852671401100
	DN 40 NO	M29852671701400	M29852671401400
	DN 50 NO	M29852671701700	M29852671401700

(*) Ensure that the compatibility of the fluids in contact with the materials is verified.

01188GB-2017/R01
Availability, design and specifications are subject to change without notice. All rights reserved.

INSTALLATION

- The valves can be mounted in any position without affecting operation
- Compatible with ASTM 1, 2 and 3 oils
- Check temperature range of valve body and solenoid pilot valves for suitability. For probability of failure, contact us
- Piloting thread connection: Pipe connections (G*) have standard thread according to ISO 228/1 and ISO 7/1.
Pipe connections (G) have standard thread according to ISO 228/1
- Piloting thread connections have standard thread = NPTF (ANSI B1.20.3)
- Declarations of conformity are available on request
- Installation/maintenance instructions are included with each valve

DIMENSIONS (mm), WEIGHT (kg)

[Configurator - CAD Files](#)

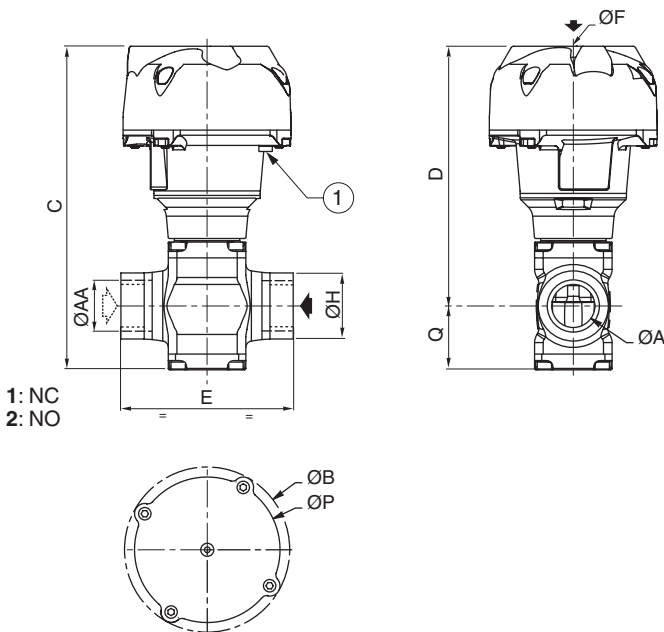
TYPE 01-02-03-04
 "E" threaded connection

 1: NC
 2: NO

① Optical position indicator

type	DN	operator diameter	ØA	ØAA	ØB	C	D	E	ØF	ØH	ØP	Q	weight	
													NC	NO
01	15	80	15	1/2"	110	184,1	151,6	85	G 1/8	33	95	32,5	1,82	1,80
02	20	100	20	3/4"	132,5	209,9	170,9	110	G 1/8	40	117	39	3,44	3,46
	25	100	25	1"	132,5	225,4	180,9	120	G 1/8	46	117	44,5	4,16	4,12
03	32	150	32	1"1/4	191	291,2	237,2	145	G* 1/4	57	172,5	54	9,32	9,26
	40	150	40	1"1/2	191	325,7	259,2	150	G* 1/4	65	172,5	66,5	11,38	11,36
04	50	200	50	2"	247	409	328,5	190	G* 1/4	75	230	80,5	23,48	21,68



VALVES

pressure operated
stainless steel body

with flanges PN40, DIN and ANSI Class 300, DN 15 to 50

NC

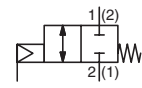

NO

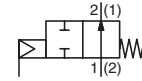

2/2
Series
T298

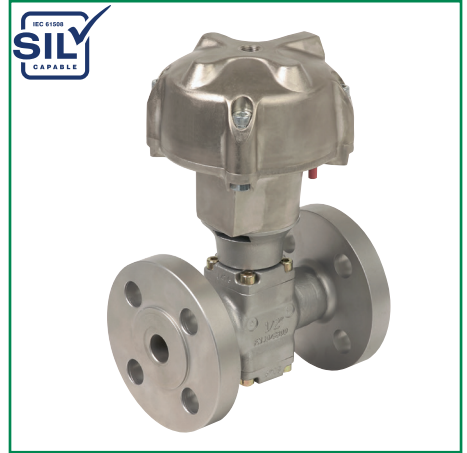

FEATURES

- Ruggedly built valve, particularly recommended for use with steam, superheated water, corrosive fluids
- High-performance, maintenance-free stuffing box, resistant to thermal shock
- Pressure can be applied to any port as needed by the process
- Anti-waterhammer design (fluid entry at orifice 1), recommended for use with liquids
- Vacuum operation up to 10^{-2} mbar (PTFE and PEEK discs)
- Optical position indicator as standard
- Autoclavable valve for use at high ambient temperatures (up to 180°C)
- The valves satisfy Pressure Equipment Directive 2014/64/EU
- The valves in conformity with IEC 61508 Standard (2010 route 2_H version) certified with integrity levels: SIL 2 for HFT = 0

GENERAL

Differential pressure	0 to 40 bar [1 bar =100 kPa]
Maximum allowable pressure	40 bar (within the specified limits, see diagram I)
Maximum back pressure	40 bar / 20 bar for PEEK sealing
Ambient temperature range	-20°C to +180°C [Option: -55°C to +70°C]
Maximum viscosity	5000 cSt (mm ² /s)
Pilot fluid	Air
Max. pilot pressure	10 bar
Min. pilot pressure	See graphs below

fluids (*)	temperature range	disc seal (*)
DN 15-20-25: air and gas groups 1 & 2 DN 32-40-50: air and gas group 2 all DN: water, oil, liquids groups 1 & 2 and steam	-10°C to +233°C	PEEK
	-10°C to +250°C	metal-to-metal
	-10°C to +180°C	PTFE

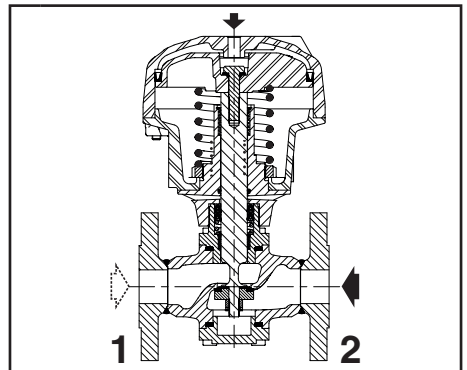

NC function

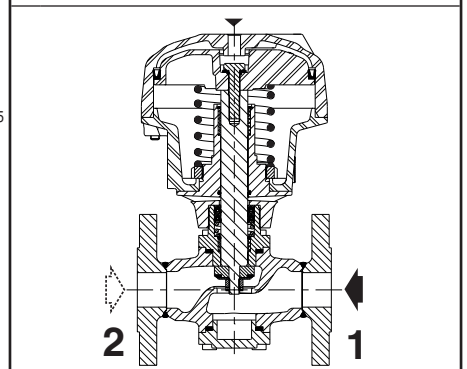

NO function

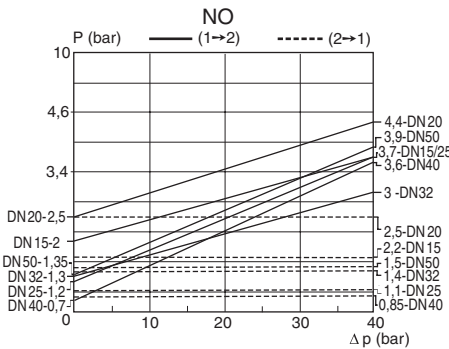
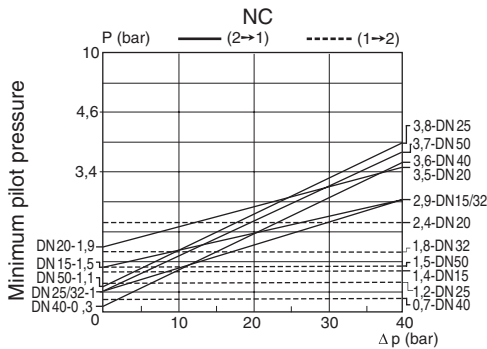

SPECIFICATIONS

Connection	Flanges PN40, type 21 (ISO 7005 / EN 1092-1) ANSI Class 300 ANSI B16-5
Face-to-face dimensions	EN 558-1
Face de joint	Type B

GENERAL

MATERIALS IN CONTACT WITH FLUID	
(*) Ensure that the compatibility of the fluids in contact with the materials is verified	
Body and plug	304 stainless steel
Stuffing box housing	304 stainless steel
Stem, disc	431 stainless steel
Stuffing box packing	PTFE chevrons
Disc seals	PEEK or PTFE or Stainless steel
Valve body seal	PTFE

OTHER MATERIALS

Operator	Aluminium, nickel plated
Screws	Galvanized steel

(*) Ensure that the compatibility of the fluids in contact with the materials is verified.

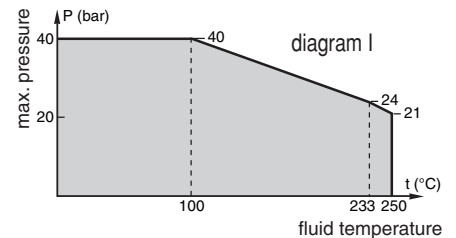

01189GB-2017/R01 Availability, design and specifications are subject to change without notice. All rights reserved.

OPTIONS

Low temperature (media and ambient temperature), PTFE disc seal (-55°C to +70°C), see "15-DIGIT PRODUCT CODE" (*) ⁽¹⁾
Oxygen service, max. fluid pressure 15 bar, max. fluid temperature 150°C, PTFE disc, see "15-DIGIT PRODUCT CODE"
Signalling box, see "15-DIGIT PRODUCT CODE": - Dual mechanical contacts or dual inductive contacts (PNP 3 wires) - Dual inductive contacts ATEX Ex ia (NAMUR 2 wires) - Dual mechanical contact ATEX Ex d IIC T6 (Crouzet contacts type 83101-I-W1, ambient temperature -20°C to +80°C) - Dual mechanical contact ATEX Ex d IIC T6 (Honeywell contact type 1HS1, ambient temperature -55°C to +70°C). Use for low temperature option
For use in explosive atmospheres, zones 1/21-2/22, categories 2-3 to ATEX Directive 2014/34/EU: Ex IIC 2GD c x°C (Tx)
CUTR Certification (EAC), see "15-DIGIT PRODUCT CODE"
Valve seat leakage class VI as defined by FCI-2 ANSI B16.104 or Class A or B following EN 12266-1, contact us
Manual override on the top of the actuator (Manual safety device), contact us
Other flange types are available on request
Re-buildable valve program; rebuild services, contact us

(*) Ensure that the compatibility of the fluids in contact with the materials is verified.

⁽¹⁾ The minimum ambient temperature of the valve is determined by the limitations of minimum temperature indicated.

SPECIFICATIONS

DN	orifice size (mm)	flow coefficient Kv				pilot pressure (bar)		operating pressure differential (bar)	operator diameter (mm)	catalogue number		
		1 → 2		2 → 1		disc sealing						
		(m³/h)	(l/min)	(m³/h)	(l/min)	min.	max.			PTFE	PEEK	metal-to-metal
NC - Normally closed										Flanges DIN EN 1092-1		
15	15	4,4	73	5	83	*	10	40	80	T298B037DTA0000	T298B037DVA0000	T298B037DEA0000
20	20	7,7	128	8,5	142	*	10	40	100	T298B04DDTA0000	T298B04DDVA0000	T298B04DDEA0000
25	25	11,5	192	12	200	*	10	40	100	T298B05DDTA0000	T298B05DDVA0000	T298B05DDEA0000
32	32	18	300	18	300	*	10	40	150	T298B06KDTA0000	T298B06KDVA0000	T298B06KDEA0000
40	40	29	483	29	483	*	10	40	150	T298B07KDTA0000	T298B07KDVA0000	T298B07KDEA0000
50	50	57	950	57	950	*	10	40	200	T298B08MDTA0000	T298B08MDVA0000	T298B08MDEA0000
NO - Normally open										Flanges ANSI 300		
15	15	4,4	73	5	83	*	10	40	80	T298B038PTA0000	T298B038PVA0000	T298B038PEA0000
20	20	7,7	128	8,5	142	*	10	40	100	T298B04EPTA0000	T298B04EPVA0000	T298B04EPEA0000
25	25	11,5	192	12	200	*	10	40	100	T298B05EPTA0000	T298B05EPVA0000	T298B05EPEA0000
32	32	18	300	18	300	*	10	40	150	T298B06LPTA0000	T298B06LPVA0000	T298B06LPEA0000
40	40	29	483	29	483	*	10	40	150	T298B07LPTA0000	T298B07LPVA0000	T298B07LPEA0000
50	50	57	950	57	950	*	10	40	200	T298B08NPTA0000	T298B08NPVA0000	T298B08NPEA0000
NO - Normally open										Flanges DIN EN 1092-1		
15	15	3,5	58	3,5	58	*	10	40	80	T298B137DTA0000	T298B137DVA0000	T298B137DEA0000
20	20	7,2	120	7	117	*	10	40	100	T298B14DDTA0000	T298B14DDVA0000	T298B14DDEA0000
25	25	11	183	11	183	*	10	40	100	T298B15DDTA0000	T298B15DDVA0000	T298B15DDEA0000
32	32	18	300	15	250	*	10	40	150	T298B16KDTA0000	T298B16KDVA0000	T298B16KDEA0000
40	40	28,2	470	28,2	470	*	10	40	150	T298B17KDTA0000	T298B17KDVA0000	T298B17KDEA0000
50	50	53	883	53	883	*	10	40	200	T298B18MDTA0000	T298B18MDVA0000	T298B18MDEA0000
NO - Normally open										Flanges ANSI 300		
15	15	3,5	58	3,5	58	*	10	40	80	T298B138PTA0000	T298B138PVA0000	T298B138PEA0000
20	20	7,2	120	7	117	*	10	40	100	T298B14EPTA0000	T298B14EPVA0000	T298B14EPEA0000
25	25	11	183	11	183	*	10	40	100	T298B15EPTA0000	T298B15EPVA0000	T298B15EPEA0000
32	32	18	300	15	250	*	10	40	150	T298B16LPTA0000	T298B16LPVA0000	T298B16LPEA0000
40	40	28,2	470	28,2	470	*	10	40	150	T298B17LPTA0000	T298B17LPVA0000	T298B17LPEA0000
50	50	53	883	53	883	*	10	40	200	T298B18NPTA0000	T298B18NPVA0000	T298B18NPEA0000

* Minimum pilot pressure varies with differential pressure. See piloting chart preceding page.

HOW TO ORDER

[Configurator - CAD Files](#)

15-DIGIT PRODUCT CODE

T 298 B 0 3 7 D V A00 00

Connection
T = Flanges

Product series
298

Revision letter
B = New Stuffing Box and Disc Materials

Function
0 = Normally closed
1 = Normally open

Diameter (mm)

- 3 = 15 mm
- 4 = 20 mm
- 5 = 25 mm
- 6 = 32 mm
- 7 = 40 mm
- 8 = 50 mm

Operator Dia. - Piloting Connection Dia.

- 7 = Ø80 mm - G 1/8
- 8 = Ø80 mm - NPT 1/8 ⁽¹⁾
- D = Ø100 mm - G 1/8
- E = Ø100 mm - NPT 1/8 ⁽¹⁾
- K = Ø150 mm - G 1/4
- L = Ø150 mm - NPT 1/4 ⁽¹⁾
- M = Ø200 mm - G 1/4
- N = Ø200 mm - NPT 1/4 ⁽¹⁾

⁽¹⁾ Connection = NPTF (ANSI B1.20.3) / Flanges ANSI Class 300

Options

- A00 = Without
- AT1 = ATEX zones 1/21
- AT2 = ATEX zones 2/22
- LTP = PTFE disc for low temperature (-55°C to +70°C)
- MC2 = Dual mechanical Contacts
- AD2 = Dual position Contact ATEX Ex d
- 1S2 = Dual position Contact NAMUR ATEX Ex i
- 1C2 = Dual inductive contacts PNP 3 wires
- 02S = PTFE disc for Oxygen service
- 124 = CUTR Certification
- A24 = CUTR Certification for ATEX 1/21
- LT1 = AT1 + LTP
- LT2 = AT2 + LTP

Disc Seal Material

- T = PTFE
- E = Metal-to-metal (stainless steel)
- V = PEEK

Port Type

- D = Flanges DIN EN 1092-1 (ISO 7005) Standard
- P = Flanges ANSI Class 300

SPARE PARTS KITS CODE (*)

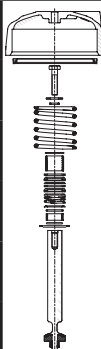
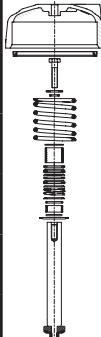
		PTFE disc seal	PEEK disc version
	DN 15 NC	M29852671700100	M29852671400100
	DN 20 NC	M29852671700400	M29852671400400
	DN 25 NC	M29852671700700	M29852671400700
	DN 32 NC	M29852671701000	M29852671401000
	DN 40 NC	M29852671701300	M29852671401300
	DN 50 NC	M29852671701600	M29852671401600
	DN 15 NO	M29852671700200	M29852671400200
	DN 20 NO	M29852671700500	M29852671400500
	DN 25 NO	M29852671700800	M29852671400800
	DN 32 NO	M29852671701100	M29852671401100
	DN 40 NO	M29852671701400	M29852671401400
	DN 50 NO	M29852671701700	M29852671401700

(*) Ensure that the compatibility of the fluids in contact with the materials is verified.

INSTALLATION

- The valves can be mounted in any position without affecting operation
- Compatible with ASTM 1, 2 and 3 oils
- Check temperature range of valve body and solenoid pilot valves for suitability. For probability of failure, contact us
- Piloting thread connection: Pipe connections (G*) have standard thread according to ISO 228/1 and ISO 7/1.
Pipe connections (G) have standard thread according to ISO 228/1
- Piloting thread connections have standard thread = NPTF (ANSI B1.20.3)
- Declarations of conformity are available on request
- Installation/maintenance instructions are included with each valve

DIMENSIONS (mm), WEIGHT (kg)

[Configurator - CAD Files](#)

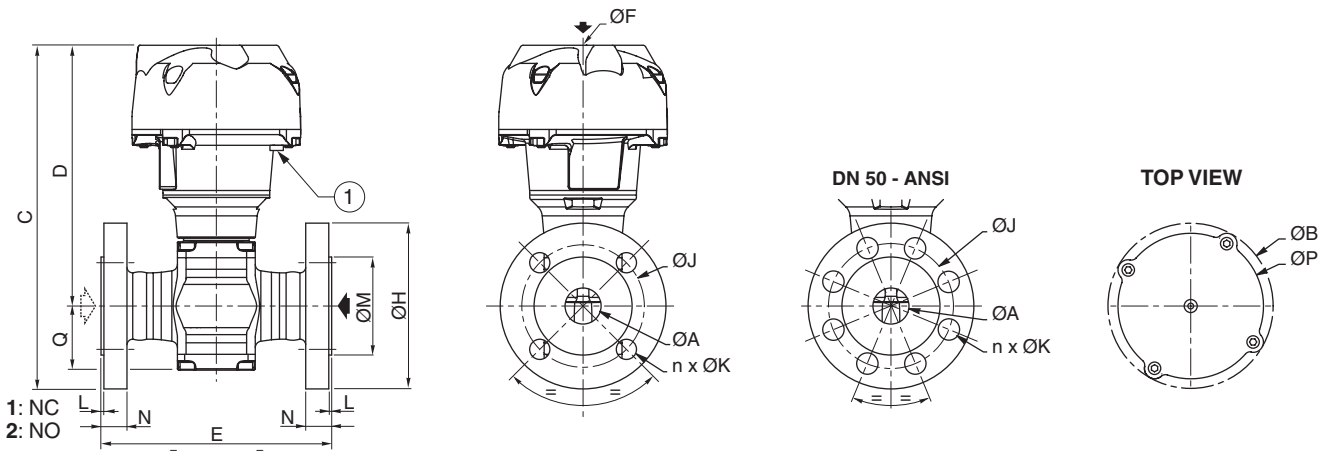

① Optical position indicator

type	DN	operator diameter	ØA	ØB	C		D	E		ØF	
					DIN	ANSI		DIN	ANSI	DIN	ANSI
01	15	80	15	110	199,1	151,6	130	140	G 1/8	NPT 1/8	
02	20	100	20	132,5	223,4	230,9	170,9	150	G 1/8	NPT 1/8	
	25	100	25	132,5	238,4	243,4	180,9	160	170	G 1/8	NPT 1/8
03	32	150	32	191	307,2	304,7	237,2	180	190	G* 1/4	NPT 1/4
	40	150	40	191	334,2	336,7	259,2	200		G* 1/4	NPT 1/4
04	50	200	50	247	411	328,5	230			G* 1/4	NPT 1/4

type	DN	operator diameter	ØH		ØJ		n x ØK		L		ØM		N		ØP	Q
			DIN	ANSI	DIN	ANSI	DIN	ANSI	DIN	ANSI	DIN	ANSI	DIN	ANSI		
01	15	80	95	65	66,5	4 x 14	4 x 16	2	1,6	45	35	16	14,2	95	32,5	
	20	100	105	120	75	82,5	4 x 14	4 x 19	2	1,6	58	43	18	15,8	117	39
02	25	100	115	125	85	89	4 x 14	4 x 19	2	1,6	68	51	18	17,5	117	44,5
	32	150	140	135	100	98,5	4 x 18	4 x 19	2	1,6	78	64	18	19,1	172,5	54
03	40	150	150	155	110	114,5	4 x 18	4 x 22	2	1,6	88	73	18	20,6	172,5	66,5
	50	200	165	125	127	4 x 18	8 x 19	2	1,6	102	92	20	22,4	230	80,5	

type	DN	operator diameter	weight			
			DIN		ANSI	
			NC	NO	NC	NO
01	15	80	3,3	3,3	3,2	3,2
	20	100	5,6	5,6	5,9	5,9
02	25	100	6,8	6,7	7,2	7,1
	32	150	13,2	13,2	13,2	13,3
03	40	150	16,4	16,4	17,2	17,2
	50	200	30,5	28,7	30,8	29



VALVES

pressure operated
stainless steel body
with socket welding ends PN40, DN 15 to 50

NC

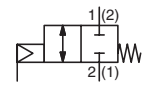

NO

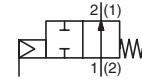

2/2
Series
W298

FEATURES

- Ruggedly built valve, particularly recommended for use with steam, superheated water, corrosive fluids
- High-performance, maintenance-free stuffing box, resistant to thermal shock
- Pressure can be applied to any port as needed by the process
- Anti-waterhammer design (fluid entry at orifice 1), recommended for use with liquids
- Vacuum operation up to 10^{-2} mbar (PTFE and PEEK discs)
- Optical position indicator as standard
- Autoclavable valve for use at high ambient temperatures (up to 180°C)
- The valves satisfy Pressure Equipment Directive 2014/64/EU
- The valves in conformity with IEC 61508 Standard (2010 route 2_H version) certified with integrity levels: SIL 2 for HFT = 0



GENERAL

Differential pressure	0 to 40 bar [1 bar =100 kPa]
Maximum allowable pressure	40 bar (within the specified limits, see diagram I)
Maximum back pressure	40 bar / 20 bar for PEEK sealing
Ambient temperature range	-20°C to +180°C [Option: -55°C to +70°C]
Maximum viscosity	5000 cSt (mm ² /s)
Pilot fluid	Air
Max. pilot pressure	10 bar
Min. pilot pressure	See graphs below

fluids (*)	temperature range	disc seal (*)
DN 15-20-25: air and gas groups 1 & 2 DN 32-40-50: air and gas group 2 all DN: water, oil, liquids groups 1 & 2 and steam	-10°C to +233°C	PEEK
	-10°C to +250°C	metal-to-metal
	-10°C to +180°C	PTFE

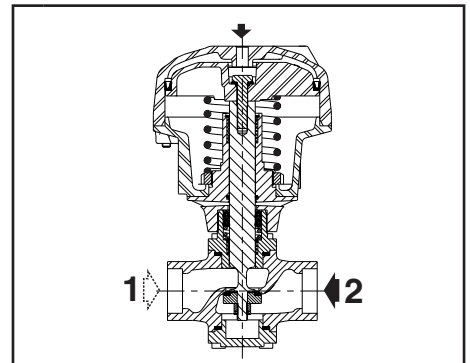

NC function

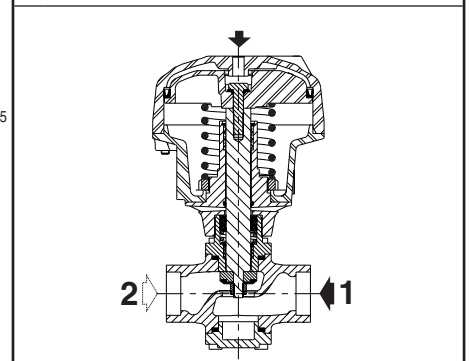

NO function

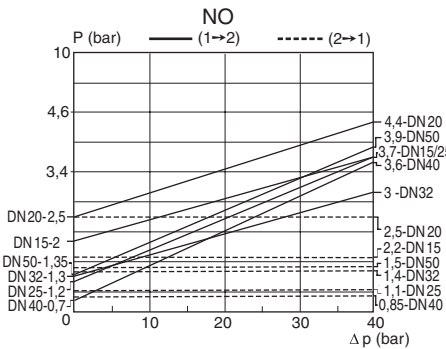
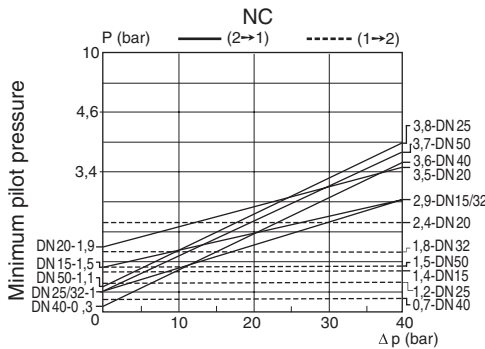

SPECIFICATIONS

Socket welding ends	EN 12760
---------------------	----------

GENERAL

MATERIALS IN CONTACT WITH FLUID	
(*) Ensure that the compatibility of the fluids in contact with the materials is verified	
Body and plug	304 stainless steel
Stuffing box housing	304 stainless steel
Stem, disc	431 stainless steel
Stuffing box packing	PTFE chevrons
Disc seals	PEEK or PTFE or Stainless steel
Valve body seal	PTFE

OTHER MATERIALS

Operator	Aluminium, nickel plated
Screws	Galvanized steel

(*) Ensure that the compatibility of the fluids in contact with the materials is verified.

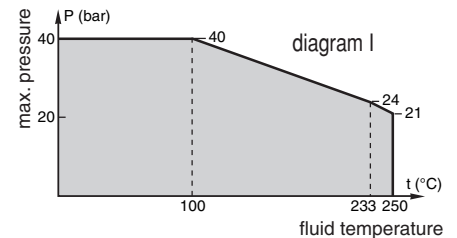

01190GB-2017/R01 Availability, design and specifications are subject to change without notice. All rights reserved.

OPTIONS

Low temperature (media and ambient temperature), PTFE disc seal (-55°C to +70°C), see "15-DIGIT PRODUCT CODE" (*) ⁽¹⁾
Oxygen service, max. fluid pressure 15 bar, max. fluid temperature 150°C, PTFE disc, see "15-DIGIT PRODUCT CODE"
Signalling box, see "15-DIGIT PRODUCT CODE": - Dual mechanical contacts or dual inductive contacts (PNP 3 wires) - Dual inductive contacts ATEX Ex ia (NAMUR 2 wires) - Dual mechanical contact ATEX Ex d IIC T6 (Crouzet contacts type 83101-I-W1, ambient temperature -20°C to +80°C) - Dual mechanical contact ATEX Ex d IIC T6 (Honeywell contact type 1HS1, ambient temperature -55°C to +70°C). Use for low temperature option
For use in explosive atmospheres, zones 1/21-2/22, categories 2-3 to ATEX Directive 2014/34/EU: Ex IIC 2GD c x°C (Tx)
CUTR Certification (EAC), see "15-DIGIT PRODUCT CODE"
Valve seat leakage class VI as defined by FCI-2 ANSI B16.104 or Class A or B following EN 12266-1, contact us
Manual override on the top of the actuator (Manual safety device), contact us
Other flange types are available on request
Re-buildable valve program; rebuild services, contact us

(*) Ensure that the compatibility of the fluids in contact with the materials is verified.

⁽¹⁾ The minimum ambient temperature of the valve is determined by the limitations of minimum temperature indicated.

SPECIFICATIONS

DN	ext. pipe diameter	flow coefficient Kv				pilot pressure (bar)		operating pressure differential (bar)	operator diameter (mm)	catalogue number		
		1 → 2		2 → 1		disc sealing						
		(mm)	(m ³ /h) (l/min)	(m ³ /h) (l/min)	(m ³ /h) (l/min)	min.	max.			PTFE	PEEK	metal-to-metal
NC - Normally closed												
15	15	4,4	73	5	83	*	10	40	80	W298B037ATA0000	W298B037AVA0000	W298B037AEA0000
20	20	7,7	128	8,5	142	*	10	40	100	W298B04DATA0000	W298B04DAVA0000	W298B04DAEA0000
25	25	11,5	192	12	200	*	10	40	100	W298B05DATA0000	W298B05DAVA0000	W298B05DAEA0000
32	32	18	300	18	300	*	10	40	150	W298B06KATA0000	W298B06KAVA0000	W298B06KAEA0000
40	40	29	483	29	483	*	10	40	150	W298B07KATA0000	W298B07KAVA0000	W298B07KAEA0000
50	50	57	950	57	950	*	10	40	200	W298B08MATA0000	W298B08MAVA0000	W298B08MAEA0000
NO - Normally open												
15	15	3,5	58	3,5	58	*	10	40	80	W298B137ATA0000	W298B137AVA0000	W298B137AEA0000
20	20	7,2	120	7	117	*	10	40	100	W298B14DATA0000	W298B14DAVA0000	W298B14DAEA0000
25	25	11	183	11	183	*	10	40	100	W298B15DATA0000	W298B15DAVA0000	W298B15DAEA0000
32	32	18	300	15	250	*	10	40	150	W298B16KATA0000	W298B16KAVA0000	W298B16KAEA0000
40	40	28,2	470	28,2	470	*	10	40	150	W298B17KATA0000	W298B17KAVA0000	W298B17KAEA0000
50	50	53	883	53	883	*	10	40	200	W298B18MATA0000	W298B18MAVA0000	W298B18MAEA0000

* Minimum pilot pressure varies with differential pressure. See piloting chart preceding page.

HOW TO ORDER

[Configurator - CAD Files](#)

15-DIGIT PRODUCT CODE

W 298 B 0 3 7 A V A00 00

Connection

W = Socket Welded

Product series
298

Revision letter

B = New Stuffing Box and Disc Materials

Function

0 = Normally closed
1 = Normally open

Diameter (mm)

3 = 15 mm
4 = 20 mm
5 = 25 mm
6 = 32 mm
7 = 40 mm
8 = 50 mm

Operator Dia. - Piloting Connection Dia.

7 = Ø80 mm - G 1/8
8 = Ø80 mm - NPT 1/8 ⁽¹⁾
D = Ø100 mm - G 1/8
E = Ø100 mm - NPT 1/8 ⁽¹⁾
K = Ø150 mm - G 1/4
L = Ø150 mm - NPT 1/4 ⁽¹⁾
M = Ø200 mm - G 1/4
N = Ø200 mm - NPT 1/4 ⁽¹⁾

⁽¹⁾ Connection = NPTF (ANSI B1.20.3)

Options

A00 = Without
AT1 = ATEX zones 1/21
AT2 = ATEX zones 2/22
LTP = PTFE disc for low temperature (-55°C to +70°C)
MC2 = Dual mechanical Contacts
AD2 = Dual position Contact ATEX Ex d
1S2 = Dual position Contact NAMUR ATEX Ex i
1C2 = Dual inductive contacts PNP 3 wires
02S = PTFE disc for Oxygen service
124 = CUTR Certification
A24 = CUTR Certification for ATEX 1/21
LT1 = AT1 + LTP
LT2 = AT2 + LTP

Disc Seal Material

T = PTFE
E = Metal-to-metal (stainless steel)
V = PEEK

SPARE PARTS KITS CODE (*)

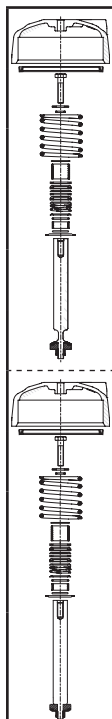

		PTFE disc seal	PEEK disc version
DN 15 NC	M29852671700100	M29852671400100	
DN 20 NC	M29852671700400	M29852671400400	
DN 25 NC	M29852671700700	M29852671400700	
DN 32 NC	M29852671701000	M29852671401000	
DN 40 NC	M29852671701300	M29852671401300	
DN 50 NC	M29852671701600	M29852671401600	
DN 15 NO	M29852671700200	M29852671400200	
DN 20 NO	M29852671700500	M29852671400500	
DN 25 NO	M29852671700800	M29852671400800	
DN 32 NO	M29852671701100	M29852671401100	
DN 40 NO	M29852671701400	M29852671401400	
DN 50 NO	M29852671701700	M29852671401700	

(*) Ensure that the compatibility of the fluids in contact with the materials is verified.

01190GB-2017/R01
Availability, design and specifications are subject to change without notice. All rights reserved.

INSTALLATION

- The valves can be mounted in any position without affecting operation
- Compatible with ASTM 1, 2 and 3 oils
- Check temperature range of valve body and solenoid pilot valves for suitability. For probability of failure, contact us
- Piloting thread connection: Pipe connections (G*) have standard thread according to ISO 228/1 and ISO 7/1.
Pipe connections (G) have standard thread according to ISO 228/1
- Piloting thread connections have standard thread = NPTF (ANSI B1.20.3)
- Declarations of conformity are available on request
- Installation/maintenance instructions are included with each valve

DIMENSIONS (mm), WEIGHT (kg)

[Configurator - CAD Files](#)

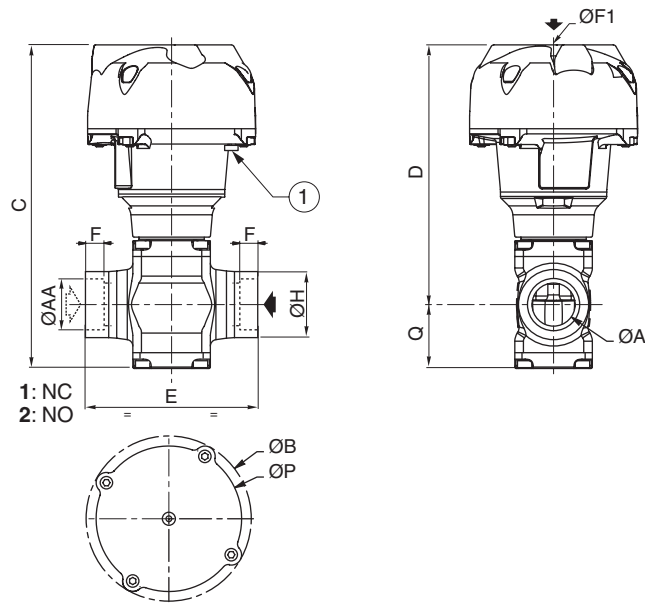
TYPE 01-02-03-04
 "W" socked welded ends

 1: NC
 2: NO

① Optical position indicator

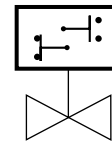
type	DN	operator diameter	ØA	ØAA	ØB	C	D	E	F	ØF1	ØH	ØP	Q	weight	
														NC	NO
01	15	80	15	22,4	110	184,1	151,6	85	9,5	G 1/8	33	95	32,5	1,81	1,79
	20	100	20	27,7	132,5	209,9	170,9	110	11	G 1/8	40	117	39	3,43	3,45
02	25	100	25	34,5	132,5	225,4	180,9	120	12,5	G 1/8	46	117	44,5	4,15	4,11
	32	150	32	43,2	191	291,2	237,2	145	14,5	G* 1/4	57	172,5	54	9,31	9,25
03	40	150	40	49,5	191	325,7	259,2	150	16	G* 1/4	65	172,5	66,5	11,38	11,36
	50	200	50	62	247	409	328,5	190	17,5	G* 1/4	75	230	80,5	23,48	21,68



FEATURES

- The signaling box fits all series 298 (2/2) and 398 (3/2) valves to indicate whether the valve is open or closed
- It is rotatable through 360° and equipped with two mechanical or inductive contacts
- The signaling box is supplied pre-installed and pre-adjusted on the valve
- The version with mechanical contacts can be used with up to max. 250 V AC and in magnetic field environments

GENERAL / OPERATION

At both end-of-travel positions (open and closed) of the valve stem, cams on the signaling box plunger operate contacts which provide an electrical signal indicating that the end position is reached.

Ambient temperature range -25°C to +80°C

CONSTRUCTION

Body, cover PA
Degree of protection IP66

Unit can be rotated through 360° around the centreline of the valve operator (set screw)

ELECTRICAL CHARACTERISTICS

mechanical contacts	inductive contacts
Breaking capacity of contacts: • resistive circuit: 3,2 A at 250 V AC • inductive circuit: 1,8 A at 250 V AC (cos $\phi = 0,8$)	• 10 to 30 V DC power supply • load current 200 mA max. • built-in electrical protection

Electrical connection

mechanical contacts 1 terminal strip with 6 screw terminals
inductive contacts 2 terminal strips with 2 screw terminals

Max. grip 2,5 mm²

Cable entry 1 cable gland (cable ϕ 5-10 mm)

SPECIFICATIONS

operator	option code ⁽¹⁾ signaling box supplied installed on valve	
	2 mechanical contacts	2 inductive contacts PNP
ϕ 80 mm, ϕ 100 mm, ϕ 150 mm, ϕ 200 mm	MC2	1C2

- ⁽¹⁾ Add the appropriate digits after the catalogue number of the selected valve, example:
 - catalogue number of valve alone **E298B0370TA0000**
 - catalogue number of valve + pre-installed inductive contacts box = **E298B0370TMC200**

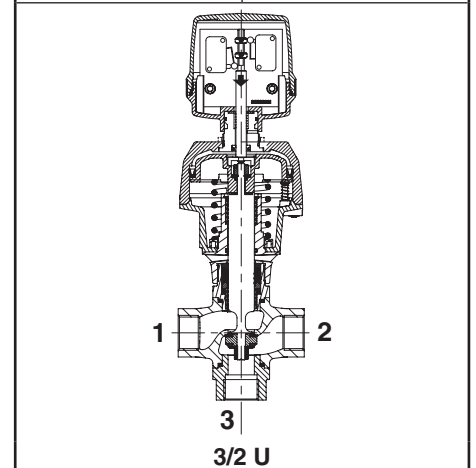
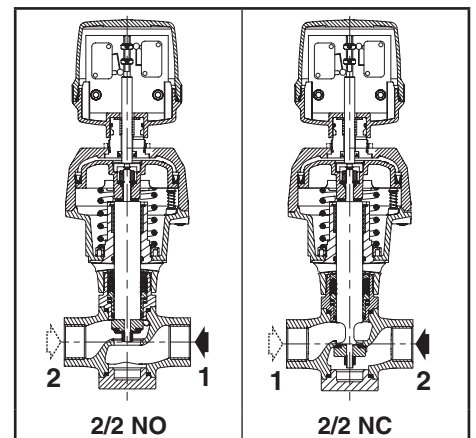

OPTIONS

- Other types of contacts: contact us

INSTALLATION

- The signaling box can be installed in any position
- Electrical connection:

mechanical contacts

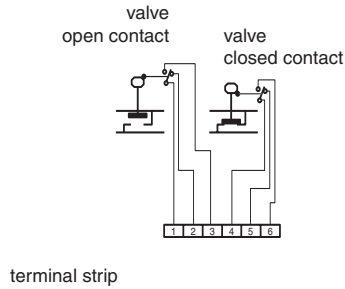

inductive contacts

(valve closed)

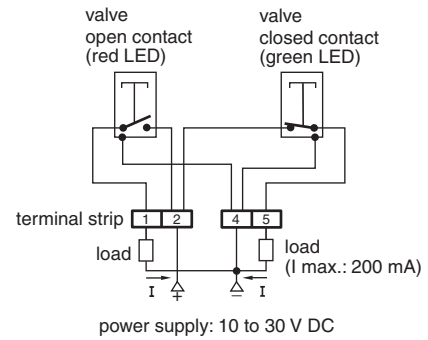

- Installation/maintenance instructions are included with each signaling box

DIMENSIONS (mm), WEIGHT (kg)

Weight of unit alone: 0,310

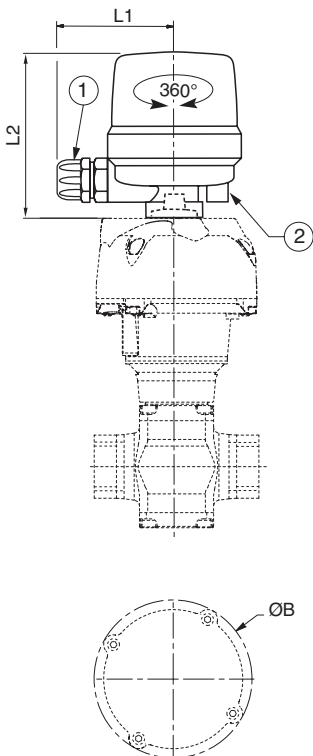

2/2 NO-NC

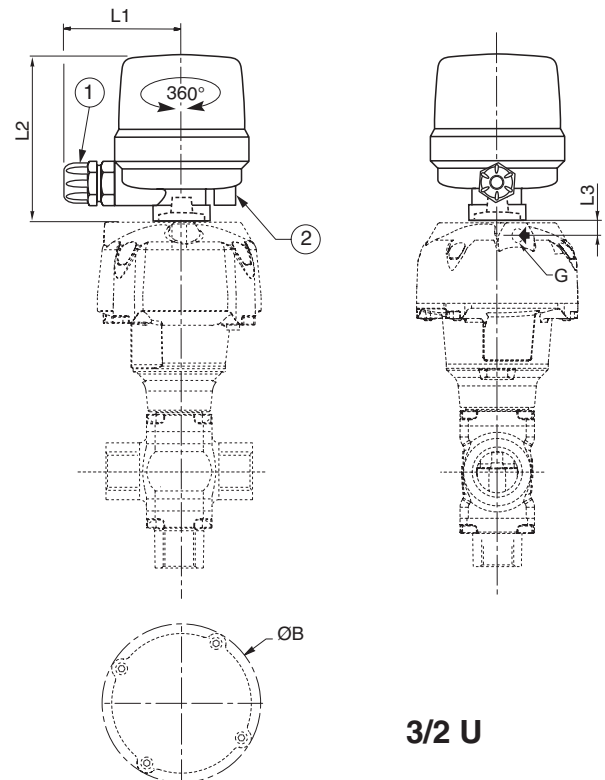

3/2 U

operator dia.	80 mm	100 mm	150 mm	200 mm
L1	68	68	68	68
L2	100	100	100	100
L3	7	8	12	15
ø G	1/8	1/8	1/4	1/4
ø B	110	132,5	191	247

① 1 cable gland (cable Ø 5-10 mm)

② Unit rotation lock set screw (orientable through 360°)



VALVES TO ATEX 2014/34/EU OPTIONS / ACCESSORIES

for potentially explosive atmospheres
series 298 and 398



2/2 - 3/2
Series
298 - 398

FEATURES

- 2/2 NC/NO or 3/2 U valves designed for use in potentially explosive atmospheres according to ATEX Directive 2014/34/EU, category 2
- Compliance with the Essential Health and Safety Requirements of the ATEX Directive has been assured by compliance with European Standards EN 13463-1 and EN 13463-5

GENERAL / CONSTRUCTION / SPECIFICATIONS

Verify the compatibility of the category/zone with the selected valve.

operator diameter		DN	catalogue page	classification (zones)				
				category 2			safety code ^(c)	
			Pressure Operated Valves: 2/2, pages ► 53 (E298), 57 (T298), 61 (S298) 3/2, pages ► 3 (E398), 7 (T398), 11 (S398)	dusts	gas			
					IIA	IIB	IIC	
Ø 80 mm		15	=	21	1	1	1	II 2 GD c x°C (Tx)
Ø 100 mm		20 → 25						
Ø 150 mm		32 → 40						
Ø 200 mm		50						

x°C ^(c)	(Tx) ^(c)	Ts amb ^(c)	T fluid ^(c)
260°C	(T2)	180°C	250°C
200°C	(T3)	180°C	195°C
135°C	(T4)	130°C	130°C
100°C	(T5)	95°C	95°C
85°C	(T6)	80°C	80°C

^(c) x°C = Surface temperature
 (Tx) = Temperature class
 Ts amb = Ambient temperature
 T fluid = Fluid temperature

ORDERING

Verify the compatibility of the category/zone with the selected valve.	option code ⁽¹⁾
	category 2
	AT1

⁽¹⁾ Example: Valve E298, DN 20, solenoid operator Ø100 mm for use in zones 1 and 21 (category 2), catalogue number: **E298B04D0VAT100**

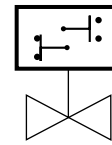

FEATURES

- The signaling box fits all series 298 (2/2) and 398 (3/2) valves to indicate whether the valve is open or closed
- The version with 2 intrinsically safe inductive NAMUR contacts is designed for use in potentially explosive atmospheres to ATEX-Directive 2014/34/EU
- Compliance with the Essential Health and Safety Requirements has been assured by compliance with the International and European Standards EN 60079-0, EN 60079-11 and EN 60076-26
- The signaling box is supplied pre-installed and pre-adjusted on the valve. It is rotatable through 360°

GENERAL / OPERATION

At both end-of-travel positions (open and closed) of the valve stem, cams on the signaling box plunger operate contacts which provide an electrical signal indicating that the end position is reached.

Safety code

⊕ II 2 GD c IIB T6 T85°C

x°C ^(c)	(Tx) ^(c)	Ts amb ^(c)	T fluid ^(c)
85°C	(T6)	80°C	80°C

^(c) x°C = Surface temperature
(Tx) = Temperature class
Ts amb = Ambient temperature
T fluid = Fluid temperature

Ambient temperature for operation of inductive detectors

-20°C to +70°C

CONSTRUCTION

Body, cover

PA

Degree of protection

IP66

Unit can be rotated through 360° around the centreline of the valve operator (set screw)

ELECTRICAL CHARACTERISTICS

intrinsically safe inductive NAMUR contacts

The protection rating of the installed signaling box depends on the type of selected valve (see page: 67).

Contact characteristics:

- Power supply: 8,2 V DC nominal
- Switching frequency: 1 kHz

Protection rating of contacts:

- ⊕ II 1G Ex ia IIB T6 Ga
- ⊕ II 2G Ex ia IIC T6 Gb
- ⊕ II 1D Ex ia IIIC T 90°C Da

- Registration & Tests:
PTB 01 ATEX 2191
BVS 04 ATEX E153
IECEx BVS 06.0003
EMC EN 60947-5-6

- Recommended interfaces:
galvanic barrier

Pepperl & Fuchs type KFA6-SR2-EX1.W
MTL instruments type MTL5011B

ZENER barrier
MTL instruments type MTL7742

Connection to certified intrinsic safety circuits with maximum values.

safety parameters				
U _i	I _i	P _i	L _i	C _i
15 V	50 mA	120 mW	110 μH	80 nF

Electrical connection of box

intrinsically safe inductive NAMUR contacts

2 terminal strips with 5 screw terminals
2,5 mm²

Max. grip

Cable entry

1 cable gland (cable Ø 5-10 mm)

SPECIFICATIONS

operator	option code ⁽¹⁾ signaling box supplied installed on valve 2 intrinsically safe inductive contacts NAMUR
Ø 80 mm, Ø 100 mm, Ø 150 mm, Ø 200 mm	1S2

⁽¹⁾ Add the appropriate digits after the catalogue number of the selected valve, example:

- catalogue number of valve alone **E298B0370TA0000**

- catalogue number of valve + pre-installed intrinsically safe inductive contacts box = **E298B0370V1S200**

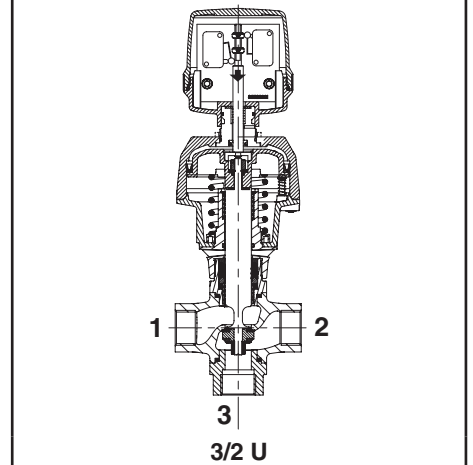
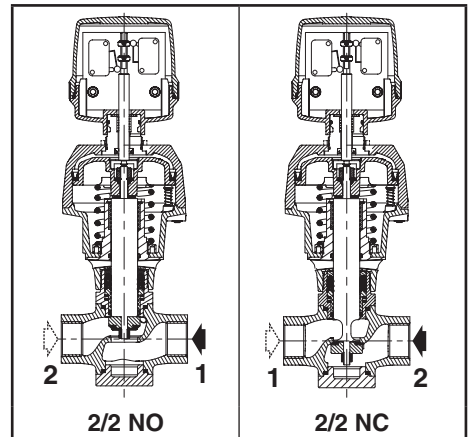

OPTIONS

- Other types of contacts: contact us

INSTALLATION

- The signaling box can be installed in any position
- Electrical connection:

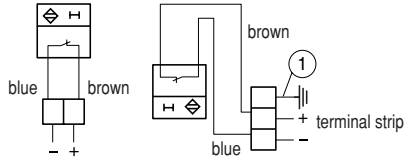

① Electrical continuity terminal

- Installation/maintenance instructions are included with each signaling box

DIMENSIONS (mm), WEIGHT (kg)

Weight of unit alone: 0,310

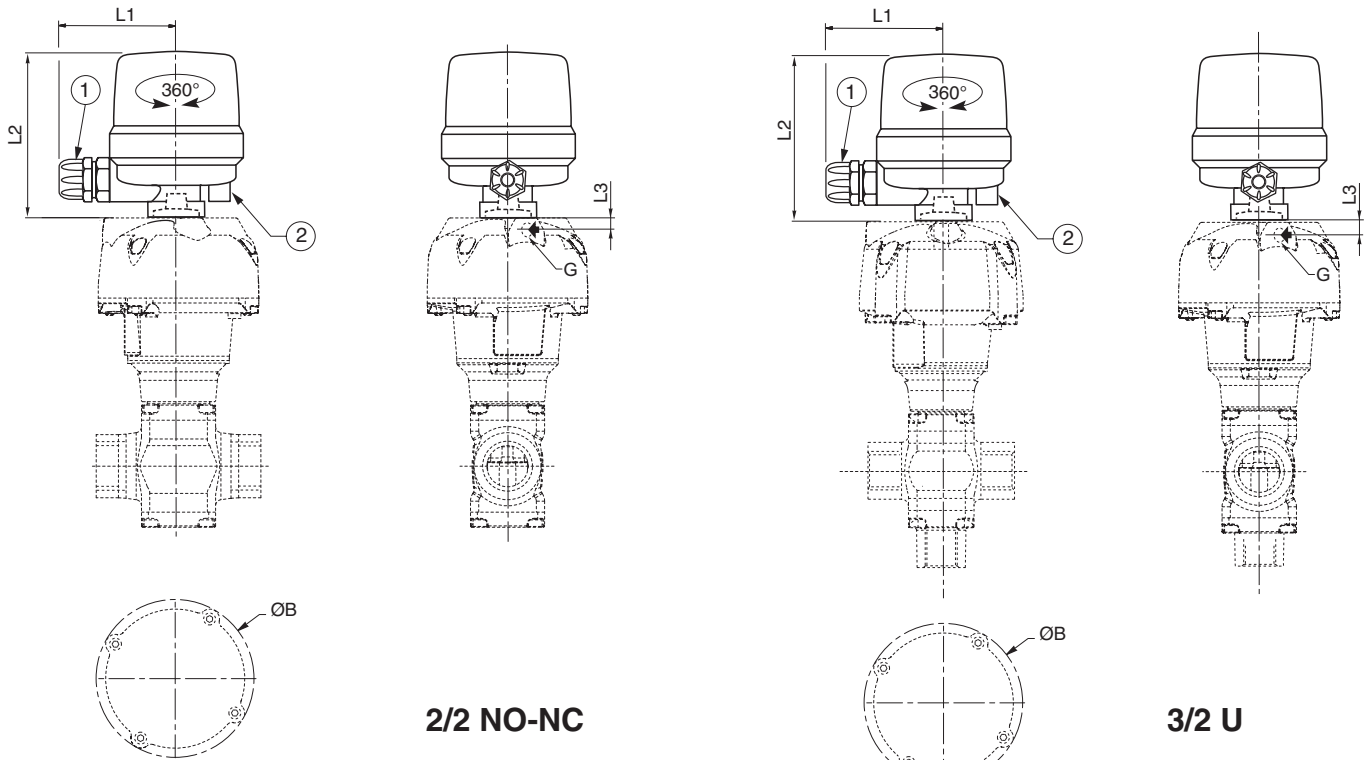

operator dia.	80 mm	100 mm	150 mm	200 mm
L1	68	68	68	68
L2	100	100	100	100
L3	7	8	12	15
ø G	1/8	1/8	1/4	1/4
ø B	110	132,5	191	247

- ① 1 cable gland (cable Ø 5-10 mm)
- ② Unit rotation lock set screw (orientable through 360°)

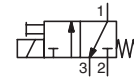

FEATURES

- Compact design and low weight enabling easy installation on all series 298 & 398 valves with dia. 80 & 100 mm operators
- Standard manual operator allows for easy installation and maintenance
- Quick disassembly of core tube for easy maintenance of internal parts
- Standard disc seal made of FPM suitable for a wide range of operating temperatures and compatible with many fluids
- AC/DC interchangeability of the solenoid without disassembling the valve
- Compliance with UL and CSA standards
- The solenoid valves satisfy all relevant EU Directives

GENERAL

Max. pilot pressure See «SPECIFICATIONS» [1 bar = 100 kPa]
Maximum viscosity 40 cSt (mm²/s)
Response time See page 7 (www.asco.com)

pilot (series)	fluids (*)	temperature range (TS)	seal materials (*)
356	filtered air and water	-10°C to +60°C	FPM (fluoroelastomer)

MATERIALS IN CONTACT WITH FLUID

(*) Ensure that the compatibility of the fluids in contact with the materials is verified

Body	Brass or AISI 316 SS
Core tube	Stainless steel
Core and plugnut	Stainless steel
Springs	Stainless steel
Seats	Brass or stainless steel
Seals	FPM
Shading coil	Copper

ELECTRICAL CHARACTERISTICS

Coil insulation class F
Connector Spade plug (cable Ø 6-7 mm)
Connector specification DIN 43650, 11 mm, industry standard B
Electrical safety IEC 335
Electrical enclosure protection Moulded IP65 (EN 60529)
Standard voltages DC (=) : 24V - 48V
 AC (~) : 24V - 48V - 115V - 230V / 50 Hz
 (Other voltages and 60 Hz on request)

prefix option	power ratings				operator ambient temperature range (TS) (C°)	replacement coil		type ⁽¹⁾
	inrush ~	holding ~	hot/cold =			~	=	
	(VA)	(VA)	(W)	(W)		230 V/50 Hz	24 V DC	
SC	12	6	4	5 / 6,9	-10 to +60	400127-197	400127-142	02

⁽¹⁾ Refer to the dimensional drawings on the following page.

SPECIFICATIONS

pipe size	orifice size		flow coefficient Kv				operating pressure differential (bar)				power coil (W)		catalogue number with maintained manual operator ~/=	
	2→1 (mm)	1→3 (mm)	2→1		2→3		min. ⁽⁴⁾	max. (PS)		~	=			
			(m ³ /h)	(l/min)	(m ³ /h)	(l/min)		air (*)	water (*)					
G														
NC - Normally closed, series 356 pilot, brass body														
1/8 ⁽²⁾	1,6	1,2	0,08	1,33	0,05	0,8	0	10	10	10	10	4	6,9	SCG356B059VMS ⁽³⁾
NC - Normally closed, series 356 pilot, stainless steel body														
1/8 ⁽²⁾	1,6	1,2	0,08	1,33	0,05	0,8	0	10	10	10	10	4	6,9	SCG356B060VMS ⁽³⁾

⁽²⁾ Pipe size:

- Port 1 and 2: 1/8 (series 356)
- Port 3 (exhaust): M5

⁽³⁾ Solenoid valve with 1/8 adapter.

⁽⁴⁾ Refer to leaflets on series 298/398 valves which show the minimum pilot pressure for each version of the product.



OPTIONS

- Explosionproof enclosures for use in zones 1/21-2/22, categories 2-3 to ATEX Directive 2014/34/EU (www.asco.com)
- Class H coil, max. ambient temperature +75°C, contact us
- M5 flow control regulator to fit port 3, catalogue number: **34600380**
- Connector with visual indication and peak voltage suppression or with cable length of 2 m (www.asco.com)

INSTALLATION

- The solenoid valves can be mounted in any position without affecting operation
- Pipe connection identifier is G = G (ISO 228/1)
- Installation/maintenance instructions are included with each valve

ORDERING EXAMPLES:

	SC G356B059 VMS	24V / DC
	SC G356B060 VMS	230V / 50 Hz
catalogue number _____		_____ voltage

DIMENSIONS (mm), WEIGHT (kg)



TYPE01

Prefix "SC" Solenoid
Pilot 356
Epoxy moulded
IEC 335 / DIN 43650 / IP65

SCG356B059VMS - SCG356B060VMS

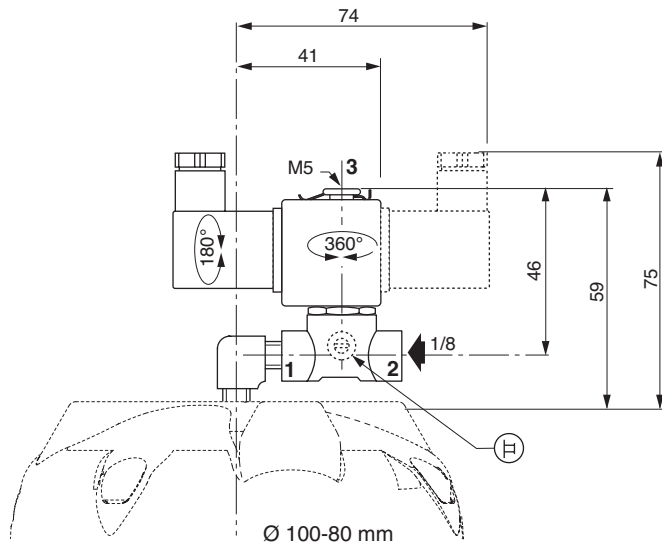

type	prefix option	pilot	operator diameter	weight ⁽¹⁾
01	SC	356 series	80 mm 100 mm	0,155

① Flow control regulator location

⁽¹⁾ Including adapter, coil and connector.



SOLENOID PILOT VALVES

for 298/398 valves, 150 & 200 mm operators
direct operated
1/4

NC

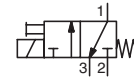

3/2
Series
314
356

FEATURES

- Compact design and low weight enabling easy installation on all series 298 & 398 valves with dia. 150 & 200 mm operators
- Standard manual operator allows for easy installation and maintenance
- Pilot 356: AC/DC interchangeability of the solenoid without disassembly of the valve
- The solenoid valves satisfy all relevant EU directives

GENERAL

Max. pilot pressure 0 to 10 bar [1 bar = 100 kPa]
Maximum viscosity 40 cSt (mm²/s)
Response time See page 7 (www.asco.com)

pilot (series)	fluids (*)	temperature range (TS)	seal materials (*)
314	filtered air and water	-10°C to +80°C	314/356 pilots: NBR (nitrile)
356			314 pilot: FPM (fluoroelastomer)



MATERIALS IN CONTACT WITH FLUID

(*) Ensure that the compatibility of the fluids in contact with the materials is verified

	Pilot 314	Pilot 356
Body	Brass or st. steel AISI 304	Brass or st. steel AISI 316
Core tube	Stainless steel	Stainless steel
Core and plugnut	Stainless steel	Stainless steel
Springs	Stainless steel	Stainless steel
Seats	Brass	Brass
Seals	NBR	FPM
Upper disc	FPM	-
Shading coil	Copper or silver	Copper

ELECTRICAL CHARACTERISTICS

Coil insulation class F
Connector Spade plug (cable Ø 6-10 mm)
Connector specification ISO 4400 / EN 175301-803, form A
Electrical safety IEC 335
Electrical enclosure protection Moulded IP65 (EN 60529)
Standard voltages DC (=) : 24V - 48V
 (Other voltages and 60 Hz on request) AC (~) : 24V - 48V - 115V - 230V / 50 Hz

prefix option	power ratings				operator ambient temperature range (TS) (C°)	replacement coil		type ⁽¹⁾
	inrush ~	holding ~	hot/cold =			~	=	
	(VA)	(VA) (W)	(W)	(W)		230 V/50 Hz	24 V DC	
-	50	25	10,1	8,5 / 11,6	-10 to +60	238613-059	238713-006	01
SC	15	7	5	5 / 6,9	-10 to +60	400727-117	400727-185	02

⁽¹⁾ Refer to the dimensional drawings on the following page.

SPECIFICATIONS (314 Series)

pipe size	orifice size	flow coefficient Kv				operating pressure differential (bar)						power coil (W)	thread type	dimensions / type ⁽¹⁾	15-DIGIT PRODUCT CODE									
		2→1		1→3		max. (PS)									brass ⁽²⁾	stainless steel ⁽²⁾	voltage code							
		(mm)	(m ³ /h)(l/min)	(m ³ /h)(l/min)	(m ³ /h)(l/min)	min. ⁽³⁾	air (*)	water (*)	-	-	-						-	~	=	24 V/50 Hz	48 V/50 Hz	115 V/50 Hz	230 V/50 Hz	24 V/DC
1/4	3,2	0,22	3,7	0,17	2,8	0	10	6	10	6	-	-	10,1	11,6	G*	01	E314K151S1N01	E314K150S1N01	FL	FR	FT	F8	F1	F9

SPECIFICATIONS (356 Series)

pipe size	orifice size	flow coefficient Kv				operating pressure differential (bar)						power coil (W)	catalogue number ⁽²⁾		
		2→1		1→3		max. (PS)							brass body	stainless steel body	
		(mm)	(mm)	(m ³ /h)(l/min)	(m ³ /h)(l/min)	min. ⁽³⁾	air (*)	water (*)	-	-	-				-
G	(mm)	(mm)	(m ³ /h)(l/min)	(m ³ /h)(l/min)	(m ³ /h)(l/min)	(m ³ /h)(l/min)		~	=	~	=	~	=		
NC - Normally closed, with maintained manual operator															
1/4	1,6	1,2	0,08	1,33	0,05	0,8	0	10	10	10	10	5	6,9	SCG356B469VMS	SCG356B474VMS

⁽²⁾ Solenoid valve with 1/4 adapter.

⁽³⁾ Refer to leaflets on series 298/398 valves which show the minimum pilot pressure for each version of the product.

All leaflets are available on: www.asco.com

Pressure Operated Valves (2/2) - 73

OPTIONS

- Explosionproof enclosures for use in zones 1/21-2/22, categories 2-3 to ATEX Directive 2014/34/EU (www.asco.com)
- flow control device to fit port 3 (to increase air-operated pilot depressurization time):
M5, catalogue number: **34600380** / 1/8, catalogue number: **34600107**
- Connector with visual indication and peak voltage suppression or with cable length of 2 m (www.asco.com)

INSTALLATION

- The solenoid valves can be mounted in any position without affecting operation
- Pipe connection 1/4 (G*) has standard combination thread according to ISO 228/1 and ISO 7/1. Pipe connection G 1/8 or G 1/4 has standard thread according to ISO 228/1
- Installation/maintenance instructions are included with each valve

SPARE PARTS KIT

catalogue number	spare parts kit no.	
	~	=
E314K151S1N01	M200071N00	M200067N00
E314K150S1N01	M200073N00	M200069N00

ORDERING EXAMPLES / VALVES:

E314K151S1N01 F8			
SC	G356B469	VMS	24V / DC
			_____ voltage
catalogue number _____			

ORDERING EXAMPLES KITS:

M200071N00
catalogue number _____

DIMENSIONS (mm), WEIGHT (kg)



TYPE 01

Electrical interface "S1" (314 pilot)
Epoxy moulded
IEC 335 / ISO 4400
IP65

E314K150S1N01/151S1N01



TYPE 02

Prefix "SC" Solenoid (Pilot 356)
Epoxy moulded
IEC 335 / ISO 4400
IP65

SCG356B469VMS - SCG356B474VMS

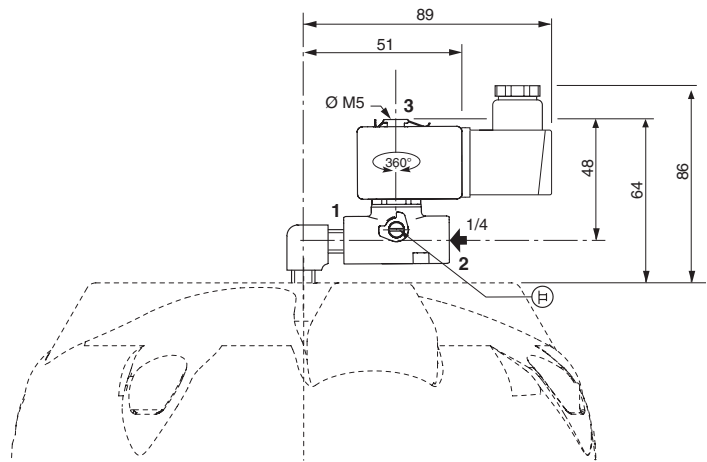
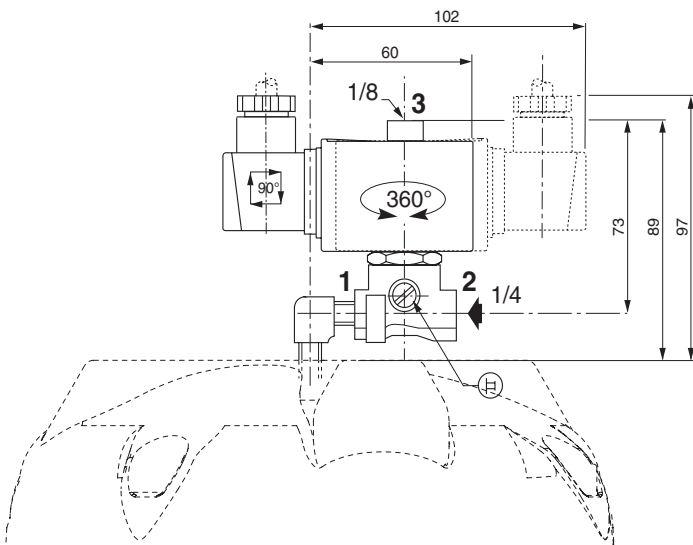

Ø 150-200 mm

type	prefix option	pilot	weight ⁽¹⁾
01	-	314 series	0,610
02	SC	356 series	0,253

⁽¹⁾ including adapter connection, coil and connector.



VALVES

pressure operated
coaxial, brass or stainless steel body
3/8 to 1

NC

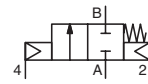

NO

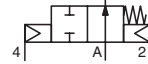

2/2
Series
287

FEATURES

- Control of high-pressure fluids
- NAMUR interface pilot for 1/4" solenoid spool valve
- Valve without actuator gland designed for long service life
- Vacuum operation up to 10⁻⁴ mbar
- The valves satisfy article 4.3 of Pressure Equipment Directive 2014/68/EU

GENERAL

Differential pressure	[1 bar = 100 kPa]
pilot 3/2 NC	A → B : 40 bar, B → A : 12 bar
pilot 5/2	A → B : 40 bar, B → A : 40 bar
Ambient temperature range	- 20°C to + 100°C
Maximum viscosity	
pilot 3/2 NC	500 cSt (mm ² /s)
pilot 5/2	6000 cSt (mm ² /s)
Pilot fluid	Air or oil
Pilot pressure	4 to 8 bar
Pilot fluid temperature	0°C à +60°C
Response time (air operation ΔP = 4 bar)	
opening (ms)	3/8 1/2 3/4 1 30 35 40 50
closing (ms)	50 60 60 70

fluids (*)	temperature range (TS)	seal materials (*)
air and gas groups 1 & 2 water, oil, liquids groups 1 & 2	- 20°C to + 100°C	FPM (fluoroelastomer) PTFE

MATERIALS IN CONTACT WITH FLUID

(*) Ensure that the compatibility of the fluids in contact with the materials is verified

	Brass body	Stainless steel body
Body	Brass	Stainless steel
Internal parts	Brass	Stainless steel
Tube	Stainless steel	Stainless steel
Seals	FPM	FPM
Disc seal	PTFE	PTFE

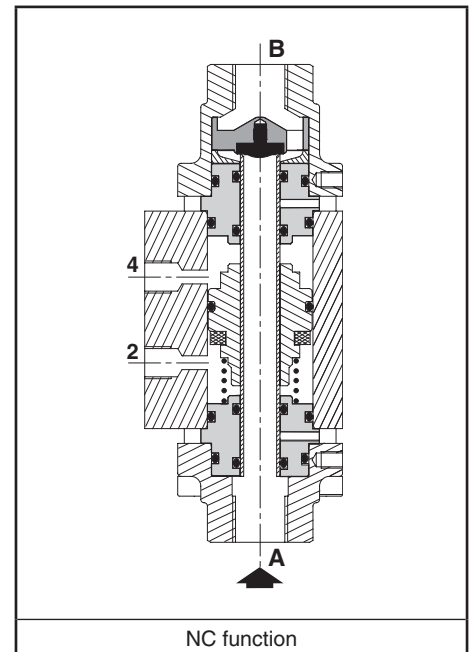

SPECIFICATIONS

pipe size	DN	flow coefficient Kv		operating pressure differential (bar)				catalogue number	
				min.	max. (PS)				
					air/gas/water/oil (*)				
G		(m ³ /h)	(l/min)		B → A	A → B	brass	stainless steel	
NC - Normally closed									
3/8	10	2,2	36,6	0	12	40	G287A101	G287A109	
1/2	15	5,2	86,6	0	12	40	G287A102	G287A110	
3/4	20	7,5	125	0	12	40	G287A103	G287A111	
1	25	12,2	203,3	0	12	40	G287A104	G287A112	
NO - Normally open									
3/8	10	2,2	36,6	0	12	40	G287A105	G287A113	
1/2	15	5,2	86,6	0	12	40	G287A106	G287A114	
3/4	20	7,5	125	0	12	40	G287A107	G287A115	
1	25	12,2	203,3	0	12	40	G287A108	G287A116	

00065GB-2017/R01
Availability, design and specifications are subject to change without notice. All rights reserved.

OPTIONS

- ATEX 2014/34/EU versions for use in zones 1/21-2/22, categories 2-3, use suffix GD2 (example: G287A101GD2)
- Magnetic position detectors (MR) "T profile":
 - with 2 m PVC lead, 3 wires 0,14 mm², stripped and tinned ends, catalogue number: **88100737**
 - with 5 m PVC lead, 3 wires 0,14 mm², stripped and tinned ends, catalogue number: **88100738**
 - with 0,15 m PVC lead + plug-in male connector Ø M8 - 3 pins, catalogue number: **88100739**
 - with 0,15 m PVC lead + screw-type male connector Ø M12 - 3 pins, catalogue number: **88100740**

INSTALLATION

- The valves can be mounted in any position without affecting operation
- Valves have two mounting holes in body
- Pipe connection identifier is G = G (ISO 228/1)
- Installation/maintenance instructions are included with each valve

SPARE PARTS KITS & ACCESSORIES

catalogue number	spare parts kit no.		mounting bracket no.
	brass	stainless steel	
G287A101/109/105/113	C140176	C140177	C140130
G287A102/110/106/114	C140180	C140181	C140131
G287A103/111/107/115	C140184	C140185	C140132
G287A104/112/108/116	C140188	C140189	C140133

ORDERING EXAMPLES:

G	287	A	101
G	287	A	105
G	287	A	109

pipe thread ————
basic number ————

DIMENSIONS (mm), WEIGHT (kg)



TYPE 01
NAMUR interface pilot

ORDERING EXAMPLES KITS:

C140176
C140181

basic number ————

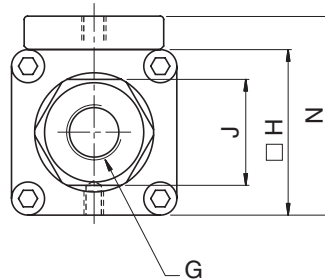
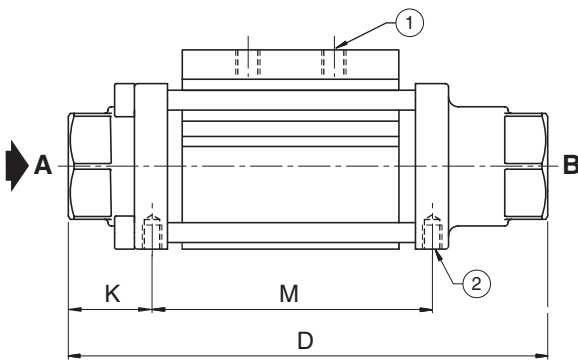

- ① 2 pilot ports G 1/8
- ② 2 mounting holes Ø M5, depth 7 mm

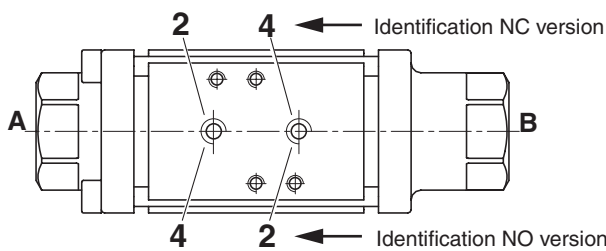

type	G	D	H	J	K	M	N	X	Y	Z	weight ⁽¹⁾
01	3/8	145	50	32	25	85	60	24	111	6	1,3
	1/2	173	70	41	31	103	68	38	136	6	2,5
	3/4	193	80	46	35	111	78	45	151	7	3,8
	1	212	90	55	36	121	88	50	165	7	5,1

⁽¹⁾ Without mounting brackets.

NAMUR interface pilot operation

<p>position detectors</p>	<p>mounting brackets</p>	<p>NAMUR solenoid valves, series 551</p>



VALVES

pressure operated
bronze body
threaded ports, 1/2 to 2

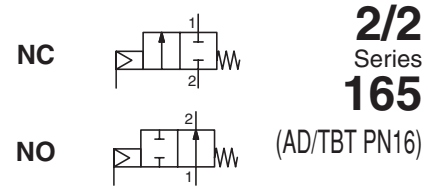

2/2
Series
165

(AD/TBT PN16)

FEATURES

- Differential-action valve for high-pressure fluid control at reduced piloting pressure
- Heavy-duty valve recommended for demanding applications
- Available with several accessories and options to handle the majority of industrial applications
- The valves satisfy Pressure Equipment Directive 2014/68/EU, category 1 (DN > 25) or article 4.3 (DN ≤ 25)

GENERAL

fluids (*)	temperature range	disc seal (*)
air and gas groups 1 & 2 water, oil, liquids groups 1 & 2 and steam	- 10°C to + 184°C	PTFE

Differential pressure	0 to 16 bar [1 bar =100 kPa]
Steam	0 to 10 bar
Maximum allowable pressure	16 bar
Ambient temperature range	-5°C to +60°C
Maximum viscosity	5000 cSt (mm ² /s)
Response time	See overleaf
Pilot fluid	Water, air, filtered
Max. pilot pressure	10 bar
Min. pilot pressure	See graphs (lower pressure: see Options)

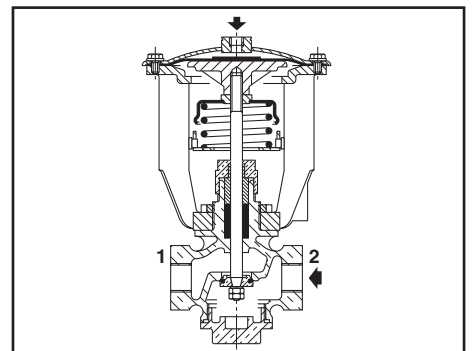
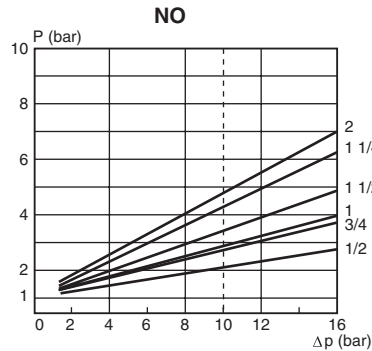
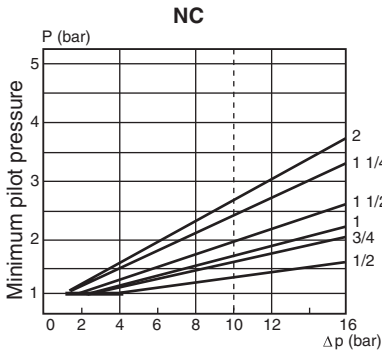

NC function

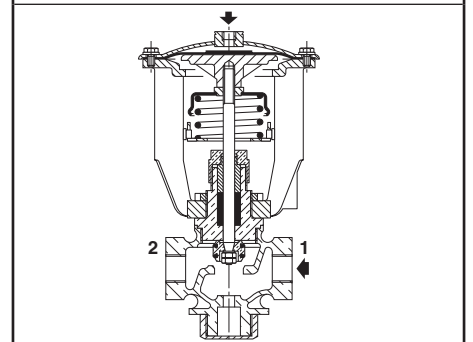

NO function

MATERIALS IN CONTACT WITH FLUID

(*) Ensure that the compatibility of the fluids in contact with the materials is verified

Valve body	Bronze
Stem	Stainless steel
Disc	Brass
Stuffing-box seal	Braided PTFE
Disc seal	PTFE
Valve body seal	FPM
Plug body	Brass or bronze

OTHER MATERIALS

Diaphragm (operator)	NBR
Bonnet (operator)	Steel

SPECIFICATIONS

piping (ISO 6708)		flow coefficient Kv		maximum allowable pressure (bar)	pilot pressure (bar)		NC normally closed		NO normally open	
pipe size (G*)	DN	(m ³ /h)	(l/min)		min.	max.	catalogue number	reference	catalogue number	reference
1/2	15	4,5	75	16	*	10	16500087	2503-TBT	16500101	2503-TBT-NO
3/4	20	7,2	120	16	*	10	16500088	2504-TBT	16500102	2504-TBT-NO
1	25	12	200	16	*	10	16500089	2505-TBT	16500103	2505-TBT-NO
1 1/4	32	18	300	16	*	10	16500090	2506-TBT	16500104	2506-TBT-NO
1 1/2	40	31,8	530	16	*	10	16500091	2507-TBT	16500105	2507-TBT-NO
2	50	39	650	16	*	10	16500092	2508-TBT	16500106	2508-TBT-NO

* The minimum pilot pressure varies according to the differential pressure across the valve. See pilot graphs above.

00058GB-2017/R01
Availability, design and specifications are subject to change without notice. All rights reserved.

OPTIONS AND ACCESSORIES

- Guard mounted on valves, 1/2 - 3/4: catalogue number **210555** / 1 - 1 1/4: catalogue number **210556** / 1 1/2 - 2: catalogue number **210557**
- Valves DN 15 to 50 to ATEX 2014/34/EU for categories 2 (II 2 GD c T6 T85°C) and 3 (II 3 GD c T6 T85°C X)
- Dry IP66 contacts
- 2 explosionproof switches with contacts for potentially explosive atmospheres to ATEX:

switch ambient temperature range	number of contacts	DN 15..32 catalogue number	DN 40..50 catalogue number
-20°C to +80°C	1	260657	260658
-20°C to +80°C	2	260660	260661
-55°C to +82°C	1	260663	260664
- Inductive M18 switch, IP66
- Inductive M18 switch, intrinsically safe to ATEX, II 1 GD EEx ia IIC T6 IP66 T85°C
- Manual override on the bonnet of the operator
- Accessories for adjustable response time (flow control, quick exhaust etc.)
- Anti-waterhammer device available with air-oil exchanger
- Backpressure applications possible by off-setting the yoke and using a reinforced spring
- Low pressure control (min. 1 bar) by off-setting the yoke
- Other types of stuffing-boxes are available depending on the nature of the fluid used
- Modifications for special environments (cold, hot, aggressive, marine etc.)
- Oxygen service, catalogue number **970509**, pressure/temperature limited to 15 bar / + 60°C
- Valve body degreased during assembly, catalogue number **970523**

INSTALLATION

- The valves can be mounted in any position, except with the operator downwards
- Be sure to observe the direction of fluid flow (NC from 2 to 1 ; NO from 1 to 2)
- Pipe connections (G*) have standard combination thread according to ISO 228/1 and ISO 7/1. Pipe connection (G) has standard thread according to ISO 228/1

SPARE PARTS KITS

DN	spare parts kit no.				guard catalogue number
	stem and disc unit		stuffing-box unit	NBR diaphragm	
	NC	NO			
15	97701319	97701351	97701320	97700017	88200035
20	97701321	97701352	97701320	97700017	88200035
25	97701322	97701353	97701320	97700018	88200036
32	97701323	97701354	97701324	97700018	88200036
40	97701325	97701355	97701324	97700019	88200037
50	97701326	97701356	97701327	97700019	88200037

ORDERING EXAMPLES:

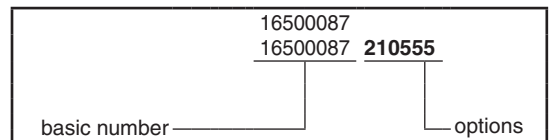

ORDERING EXAMPLES KITS:

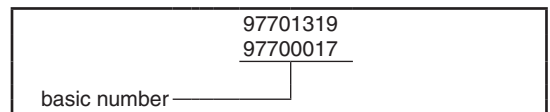

DIMENSIONS (mm), WEIGHT (kg)

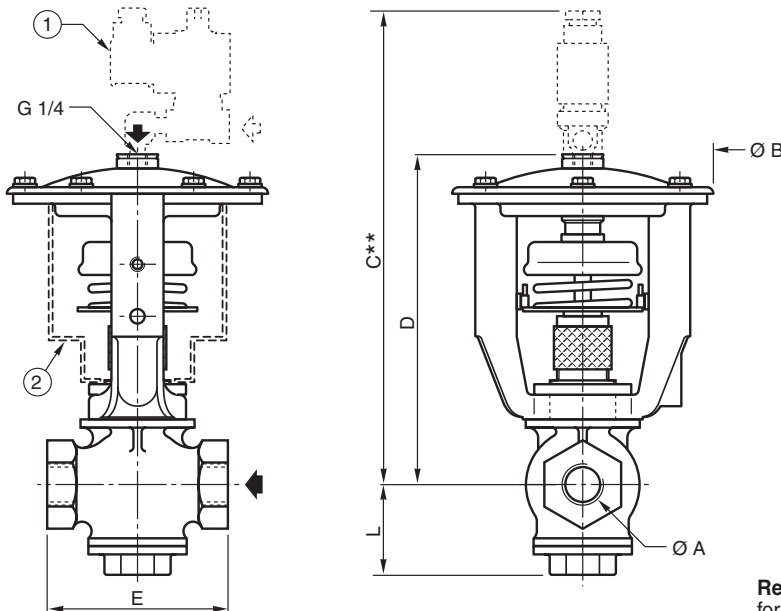

ØA (G*)	ØB	C**		D		E	L		weight ⁽¹⁾
		NC	NO	NC	NO		NC	NO	
1/2	127	284	290	165	171	68	39	46	3,5
3/4	127	289	292	170	173	84	44	51	4
1	156	306	307	187	188	92	48	56	5
1 1/4	156	311	314	192	193	110	55	61	5,5
1 1/2	200	343	344	224	225	125	60	66	10
2	200	353	352	234	233	145	70	82	12

⁽¹⁾ Weight of valve without pilot.

** Maximum value given for reference and related to choice of electric pilot.

Response time (in sec.) for a valve with NC function

ØA (G*)	pilot fluid (6 bar)			
	air		water	
	O	C	O	C
1/2	0,3	1	0,7	2
3/4	0,3	1	0,7	2
1	0,4	1,5	1,5	4
1 1/4	0,4	1,5	1,5	4
1 1/2	0,6	2,5	3	9
2	0,6	2,5	3	9

- ① Solenoid pilot valves: see page: **83** (www.asco.com)
- ② Guard available as accessory, supplied separately or mounted on valve

- Response time is directly related to the Kv of the solenoid pilot valve. The time indicated at opening (O) and closing (C) of the valve is determined by a pilot (dia. 3 mm) with a Kv of 3,5.
- For an NO valve: swap the values of O and F.
- Consult us for shorter cycle times.

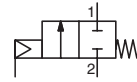

FEATURES

- Differential-action valve for high-pressure fluid control at reduced piloting pressure
- Heavy-duty valve recommended for demanding applications
- Available with several accessories and options to handle the majority of industrial applications
- The valves satisfy Pressure Equipment Directive 2014/68/EU, category 1 (DN > 25) or article 4.3 (DN ≤ 25)

GENERAL

fluids (*)	temperature range	disc seal (*)
DN ≤ 50: air and gas groups 1 & 2 DN > 50: air and gas group 2 all DN: water, oil, liquids groups 1 & 2 and steam	- 10°C to + 184°C	PTFE

Differential pressure	0 to 16 bar [1 bar = 100 kPa]
Steam	0 to 10 bar
Maximum allowable pressure	16 bar
Ambient temperature range	-5°C to +60°C
Maximum viscosity	5000 cSt (mm ² /s)
Response time	See overleaf
Pilot fluid	Water, air, filtered
Max. pilot pressure	10 bar
Min. pilot pressure	See graphs (lower pressure: see Options)

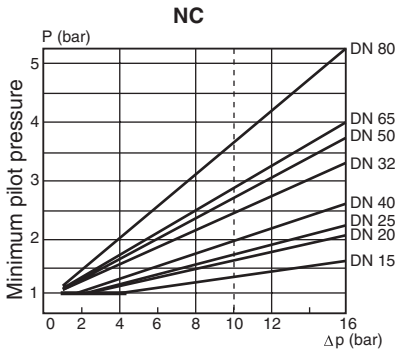
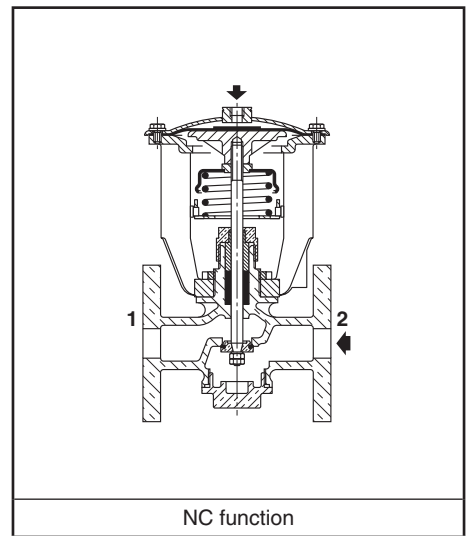

CONSTRUCTION

Connection	Flange type 21 (ISO 7005) - PN 16
Facing	Type A
Pilot connection	G 1/4

MATERIALS IN CONTACT WITH FLUID

(*) Ensure that the compatibility of the fluids in contact with the materials is verified

Valve body	Bronze
Stem	Stainless steel
Disc	Brass
Stuffing-box seal	Braided PTFE
Disc seal	PTFE
Valve body seal	FPM
Plug body	Brass or bronze

OTHER MATERIALS

Diaphragm (operator)	NBR
Bonnet (operator)	Steel

SPECIFICATIONS

DN	flow coefficient Kv		maximum allowable pressure	pilot pressure (bar)		NC normally closed	
						catalogue number	reference
15	4,5	75	16	*	10	16500093	2503-BBT
20	7,2	120	16	*	10	16500094	2504-BBT
25	12	200	16	*	10	16500095	2505-BBT
32	18	300	16	*	10	16500096	2506-BBT
40	31,8	530	16	*	10	16500097	2507-BBT
50	39	650	16	*	10	16500098	2508-BBT
65	63	1050	16	*	10	16500099	2510-BBT
80	99	1650	16	*	10	16500100	2511-BBT

* The minimum pilot pressure varies according to the differential pressure across the valve. See pilot graphs above.

OPTIONS AND ACCESSORIES

- Guard mounted on valves, DN 15-20: catalogue number **210555** / DN 25-32: catalogue number **210556** / DN 40-50: catalogue number **210557** / DN 65-80: catalogue number **210558**
- Valves DN 15 to 80 to ATEX 2014/34/EU for categories 2 (II 2 GD c T6 T85°C) and 3 (II 3 GD c T6 T85°C X)
- Dry IP66 contacts
- 2 explosionproof switches with contacts for potentially explosive atmospheres to ATEX:

switch ambient temperature range	number of contacts	catalogue number	
		DN 15..32	DN 40..80
-20°C to +80°C	1	260657	260658
-20°C to +80°C	2	260660	260661
-55°C to +82°C	1	260663	260664
- Inductive M18 switch, IP66
- Inductive M18 switch, intrinsically safe to ATEX, II 1 GD EEx ia IIC T6 IP66 T85°C
- Manual override on the bonnet of the operator
- Accessories for adjustable response time (flow control, quick exhaust etc.)
- Anti-waterhammer device available with air-oil exchanger
- Backpressure applications possible by off-setting the yoke and using a reinforced spring
- Low pressure control (min. 1 bar) by off-setting the yoke
- Other types of stuffing-boxes are available depending on the nature of the fluid used
- Modifications for special environments (cold, hot, aggressive, marine etc.)
- Other standardised flange forms
- Oxygen service, catalogue number **970509** (except DN 65 and 80), pressure/temperature limited to 15 bar / + 60°C
- Valve body degreased during assembly, catalogue number **970523**

INSTALLATION

- The valves can be mounted in any position, except with the operator downwards
- Be sure to observe the direction of fluid flow (NC from 2 to 1 ; NO from 1 to 2)
- Pipe connection (G) has standard thread according to ISO 228/1

SPARE PARTS KIT & ACCESSORIES

DN	spare parts kit no.				guard catalogue number
	stem and disc unit		stuffing-box unit	NBR diaphragm	
	NC	-			
15	97701319	-	97701320	97700017	88200035
20	97701321	-	97701320	97700017	88200035
25	97701322	-	97701320	97700018	88200036
32	97701323	-	97701324	97700018	88200036
40	97701325	-	97701324	97700019	88200037
50	97701326	-	97701327	97700019	88200037
65	97701328	-	97701329	97700045	88200038
80	97701330	-	97701329	97700045	88200038

ORDERING EXAMPLES:

16500093	16500094	210555
basic number _____		options _____

ORDERING EXAMPLES KITS:

97701319	97700017
basic number _____	

DIMENSIONS (mm), WEIGHT (kg)

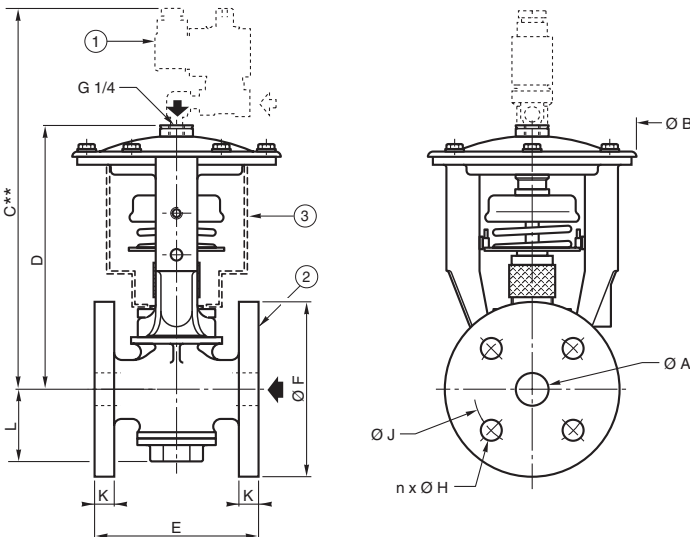

ØA (mm)	ØB	C**		D		E	ØF	n x ØH	ØJ	K	L		weight ⁽¹⁾
		NC	-	NC	-						NC	-	
15	127	284	-	165	-	90	95	4 x Ø14	65	10	39	-	4,5
20	127	289	-	170	-	100	105	4 x Ø14	75	12	44	-	5,5
25	156	306	-	187	-	110	115	4 x Ø14	85	12	48	-	7
32	156	311	-	192	-	130	140	4 x Ø18	100	14	55	-	9
40	200	343	-	224	-	140	150	4 x Ø18	110	14	60	-	14
50	200	353	-	234	-	160	165	4 x Ø18	125	16	70	-	17
65	250	405	-	270	-	170	185	4 x Ø18	145	16	92,5	-	24
80	250	413	-	278	-	205	200	8 x Ø18	160	18	100	-	30

⁽¹⁾ Weight of valve without pilot.

** Maximum value given for reference and related to choice of electric pilot.

Response time (in sec.) for a valve with NC function

ØA (mm)	pilot fluid (6 bar)			
	air		water	
	O	C	O	C
15	0,3	1	0,7	2
20	0,3	1	0,7	2
25	0,4	1,5	1,5	4
32	0,4	1,5	1,5	4
40	0,6	2,5	3	9
50	0,6	2,5	3	9
65	0,8	4	5	9
80	0,8	4	5	15

- ① Solenoid pilot valves: see page: **83** (www.asco.com)
- ② Flange type 21 with flat faces, type A (ISO 7005)
- ③ Guard available as accessory, supplied separately or mounted on valve

- Response time is directly related to the Kv of the solenoid pilot valve. The time indicated at opening (O) and closing (C) of the valve is determined by a pilot (dia. 3 mm) with a Kv of 3,5.
- Consult us for shorter cycle times.

FEATURES

- The EN air/oil exchanger, specially designed for type AD differential action valves, ensures smooth and regular movement of the valve plunger to avoid waterhammer effect in certain applications
- It can be supplied pre-installed on a valve or separately for fitting on-site to any valve in service

OPERATION

Compressed air enters via the central boss in the upper dome. The resulting force is transmitted to the plunger of the valve by the flow of oil at a controlled rate through a needle valve, ensuring smooth action.

Depending on the function required, three operating modes are available:

- Mode "A"** Bi-directional with damping in both directions. The descent time must not exceed 20 seconds.
- Mode "B"** Uni-directional, downward movement damped.
- Mode "C"** Uni-directional, upward movement damped.

The letter indicates the mode.

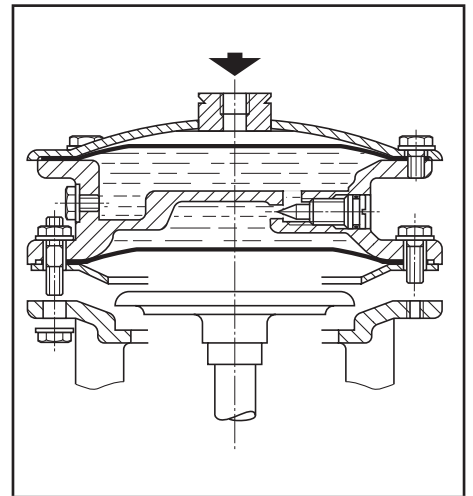
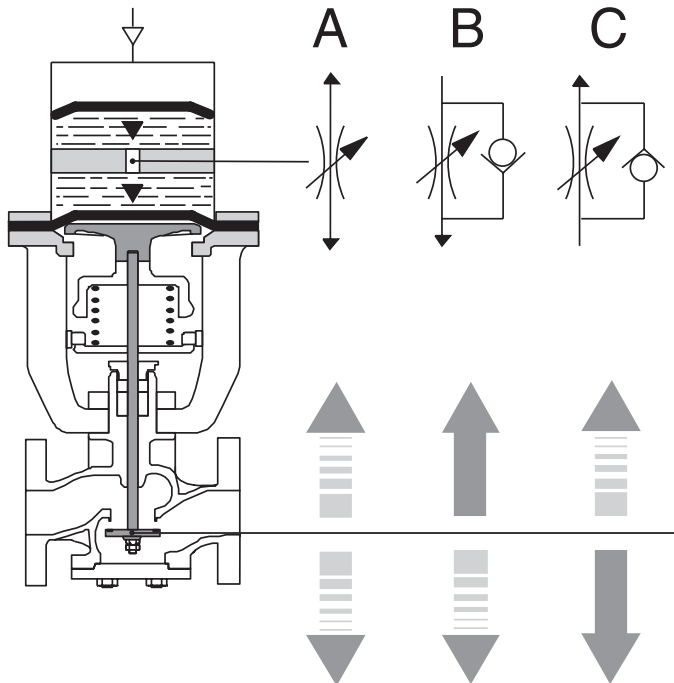

GENERAL

control fluid (*)	temperature range	diaphragms (*)
air, filtered	+5°C to +50°C	PA-reinforced synthetic rubber

Max. pilot pressure	10 bar [1 bar =100 kPa]
Recommended oil	Non-detergent, without aggressive additives
Ambient temperature range	-5°C to +50°C
Maximum viscosity	20 to 50 cSt (mm ² /s) at 50°C

CONSTRUCTION

Pilot connection G 1/4

MATERIALS IN CONTACT WITH FLUID

(*) Ensure that the compatibility of the fluids in contact with the materials is verified

Body	Cast iron
Domes (upper/lower)	Cast iron
Diaphragms ⁽¹⁾	PA-reinforced synthetic rubber

⁽¹⁾ The upper diaphragm is designed to prevent the risk of emulsion formation by separating the oil from the control air.

SPECIFICATIONS

DN	average capacity (liters)	yoke	mode	catalogue number		reference
				air/oil exchanger installed on valve ⁽²⁾	air/oil exchanger sold separately	
15 ⁽¹⁾ - 20 ⁽¹⁾ 25 - 32	0,215	NB	A	335505	21800005	ENB
			B	335506	21800006	
			C	335507	21800007	
40 - 50	0,500	NC	A	335508	21800008	ENC
			B	335509	21800009	
			C	335510	21800010	
65 - 80	1,250	ND	A	335511	21800011	END
			B	335512	21800012	
			C	335513	21800013	

⁽¹⁾ Yoke offset on 15 and 20 dia. PN16 and PN25 valves.

⁽²⁾ Number to be added to the catalogue number of the valve, see "ordering examples".

OPTIONS AND ACCESSORIES

- Ambient temperature -20°C

INSTALLATION

- Installed on type AD valves in vertical position
- **Do not pressurise the air/oil exchanger before installation is completed**
- Adjustment screw and drain screw incorporated in the air/oil exchanger body
- The air/oil exchanger is filled with oil, even when supplied as a separate part
- Pipe connection identifier is G = G (ISO 228/1)
- Installation/maintenance instructions are included with each valve

ORDERING EXAMPLES:

	21800005		16500087	335505
basic number				options

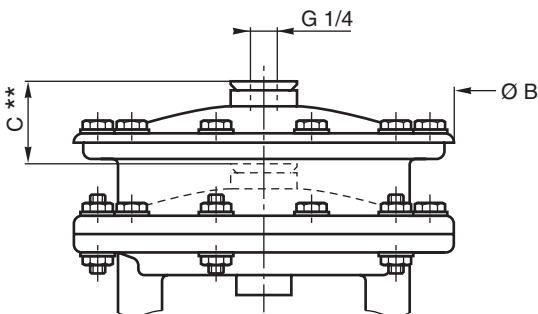
DIMENSIONS (mm), WEIGHT (kg)

reference	ØB	C**	weight
ENB	156	47	2,4
ENC	200	52	3,6
END	250	76	7,6

** Additional dimension to be added to dimension C of a standard valve.

Note: The air/oil exchanger cannot be fitted with a manual operator.

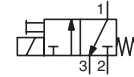

FEATURES

- Compact design and low weight enabling easy installation on all AD valves
- Manual operator allows an easy installation
- The solenoid valves satisfy all relevant EU Directives

GENERAL

Max. pilot pressure 0 to 10 bar [1 bar = 100 kPa]
Maximum viscosity 40 cSt (mm²/s)
Response time See AD valve leaflets

fluids (*)	temperature range (TS)	seal materials (*)
filtered air and water	-10°C to +80°C	NBR (nitrile)

MATERIALS IN CONTACT WITH FLUID

(*) Ensure that the compatibility of the fluids in contact with the materials is verified

Body Brass or st. steel AISI 304
Core tube Stainless steel
Core and plugnut Stainless steel
Springs Stainless steel
Seats Brass
Seals NBR
Upper disc FPM
Shading coil Copper or silver

ELECTRICAL CHARACTERISTICS

Coil insulation class F
Connector Spade plug (cable Ø 6-10 mm)
Connector specification ISO 4400 / EN 175301-803, form A
Electrical safety IEC 335
Electrical enclosure protection Moulded IP65 (EN 60529)
Standard voltages
 DC (=) : 24V - 48V
 AC (~) : 24V - 48V - 115V - 230V / 50 Hz

power ratings				operator ambient temperature range (TS)	replacement coil		type ⁽¹⁾
inrush ~	holding ~		hot/cold =		~	=	
(VA)	(VA)	(W)	(W)	(C°)	230 V/50 Hz	24 V DC	
50	25	10,1	8,5 / 11,6	-10 to +60	238613-059	238713-006	01

⁽¹⁾ Refer to the dimensional drawings on the following page.

SPECIFICATIONS

pipe size	orifice size	flow coefficient Kv				operating pressure differential (bar)					power coil (W)	thread type	dimensions / type ⁽¹⁾	15-DIGIT PRODUCT CODE										
		2 → 1		1 → 3		max. (PS)								brass ⁽²⁾	stainless steel ⁽²⁾	voltage code								
		min. ⁽³⁾	air (*)	water (*)	-	-	-	-	-	24 V/50 Hz						48 V/50 Hz	115 V/50 Hz	230 V/50 Hz	24 V/DC	48 V/DC				
1/4	3,2	0,22	3,7	0,17	2,8	0	10	6	10	6	-	-	10,1	11,6	G*	01	E314K151S1N01	E314K150S1N01	FL	FR	FT	F8	F1	F9

⁽²⁾ Solenoid valve with 1/4 adapter.

⁽³⁾ Refer to leaflets on series 165/166 valves which show the minimum pilot pressure for each version of the product.

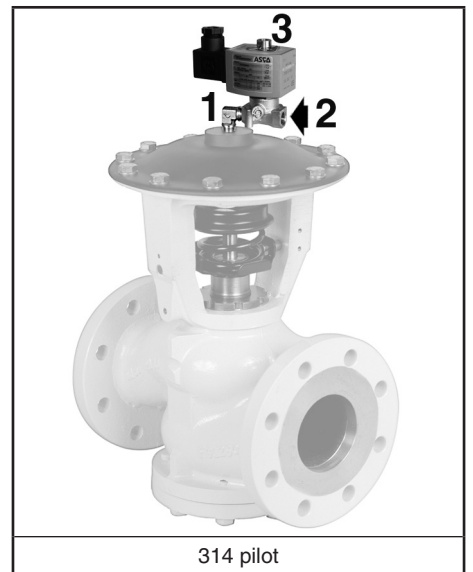

00064GB-2017/R01 Availability, design and specifications are subject to change without notice. All rights reserved.

OPTIONS

- Explosionproof enclosures for use in zones 1/21-2/22, categories 2-3 to ATEX Directive 2014/34/EU (www.asco.com)
- Connector with visual indication and peak voltage suppression or with cable length of 2 m (www.asco.com)
- flow control device to fit port 3 (to increase air-operated pilot depressurization time): - G 1/8, catalogue number: **34600107**
- Class H coil

INSTALLATION

- The solenoid valves can be mounted in any position without affecting operation
- Pipe connection 1/4 (G*) has standard combination thread according to ISO 228/1 and ISO 7/1. Pipe connection G 1/8 has standard thread according to ISO 228/1
- Installation/maintenance instructions are included with each valve

SPARE PARTS KIT

catalogue number	spare parts kit no.	
	~	=
E314K151S1N01	M200071N00	M200067N00
E314K150S1N01	M200073N00	M200069N00

ORDERING EXAMPLES:

E314K151S1N01 F8 _____ voltage
 15-digit product code _____

ORDERING EXAMPLES KITS:

M200071N00
 basic number _____

DIMENSIONS (mm), WEIGHT (kg)



TYPE 01

Electrical interface "S1" (314 pilot)
 Epoxy moulded
 IEC 335 / ISO 4400
 IP65

E314K150S1N01/151S1N01

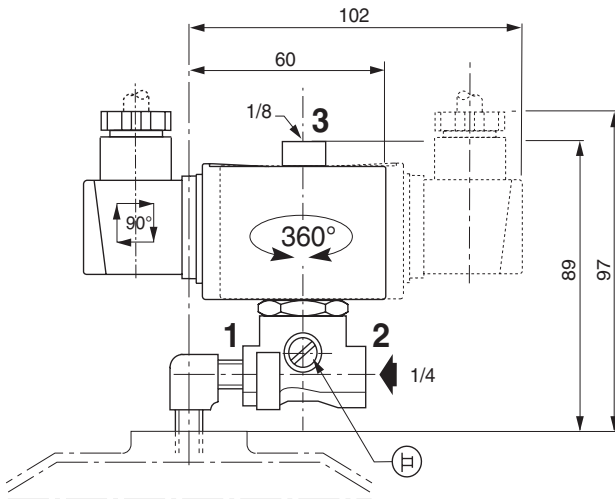

weight ⁽¹⁾
0,610

⁽¹⁾ including adapter connection, coil and connector.