

Driving future mobility

Elmos ICs bring innovation into the customer's system. Innovation Matters - this is our claim. We are one of the world's most experienced semiconductor companies for the automotive industry. Our components communicate, measure, regulate and control safety, comfort, powertrain and network functions. For over 35 years, Elmos has been bringing new functions to life and making mobility worldwide safer, more comfortable and more energy efficient. With our solutions we are already the worldwide #1 in applications with great future potential, such as ultrasonic distance measurement, ambient light and intuitive HMI.

Elmos ICs serve the following global megatrends:

- Autonomous driving
- Electromobility/CO₂ reduction
- Safety, connectivity and comfort

With locations all over the world, we are represented in all key markets and always close to the customer. Our business model encompasses the entire process of a semiconductor: innovative teams create ideas and develop, produce and market the electronic components that make the difference.

For driving future mobility, we provide our customers

- Highly specialised research and development teams
- International customer support
- Worldwide production and distribution network



Made for you: Perfectly fitting ICs

Next to a broad range of ASSPs (Application Specific Standard Product) Elmos offers ASICs (Application Specific Integrated Circuit), that are specifically designed to the customer's needs. The advantage of an ASIC: The special chip is tailor-made for use in the customer application and its individual design stays protected.

Best possible system integration, which means creating a higher functionality whilst simultaneously reducing the complexity at system level, is the target of the work. System knowledge combined with expertise and the optimal choice of possible integration strategies are prerequisites for success.

Our design teams are experts in the following application fields:

- **Sensor ICs**
Ultrasonic Distance, Sensor Signal Processor, Optical IR, Smoke Detector, Passive Infrared
- **Motor Control ICs**
Stepper Motor, Brushless DC, DC Motor
- **Interface ICs**
PSI5, LIN/CAN, KNX/EIB
- **Power Management ICs**
LED Driver, DC/DC Converter, Low Dropout (LDO) Regulator
- Other applications requiring a smart mixed-signal semiconductor solution.

Regardless of which solution you prefer, may it be a standard ASSP or a customized ASIC, Elmos always offers you the perfectly fitting semiconductor for your application.



Table of Content

Sensors

Ultrasonic	4
SSP: Sensor Signal Processor for Resistive Bridges	10
IAPS: Integrated Absolute Pressure System	14
Optical IR Sensor (HALIOS®)	16
ToF Imager	22
Passive Infrared Sensors	24
Boards	28

Motor Control

Stepper Motor	30
BLDC Motor Switched Reluctance Motor	34
DC Motor	40
Boards	46

Power Management

LED Drivers	48
DC/DC Converters	54
LDO	58
Boards	60

Interface

PSI5 Transceiver	64
CAN Transceiver and System Basis Chip	66
LIN Transceiver and System Basis Chip	68
KNX/EIB Transceiver	72
Boards	76

Special Projects

Safety	78
Engine Management	82
Relay Driver	84
Boards	88

Elmos Semiconductor SE (hereinafter: "Elmos") reserves the right to make changes to the products contained in this catalog without prior notice. This catalog does not constitute an offer to sell any products. Elmos does not assume any responsibility (neither liability nor warranty) for any inaccuracy or incompleteness of the information provided. Elmos does not assume any liability regarding damages caused by the use of any information provided, including any kind of information that is incomplete or

incorrect, unless (and only to the extent) statutory law requires Elmos mandatorily to assume liability (e.g. in cases of intent).

Circuit diagrams may contain components not being manufactured by Elmos, which are included as means of illustrating typical applications. Reproduction of this catalog, in part or whole, without the prior written consent of Elmos, is expressly prohibited. © Elmos Semiconductor SE, 2021.

Sensors - Ultrasonic

IO pt-to-pt Interface

Part No. / Description	V _{SUPPLY}	Transducer frequency	Architecture	Transducer driver type / output	Measurable Distance*	Interface	Package	Comment
E524.08 2 nd Generation Ultrasonic Transducer Driver and Signal Processor	6V to 18V	30kHz to 83kHz	pt-to-pt	transformer / 168mA to 354mA	10cm - 600cm	proprietary bidirectional IO (2-wire)	QFN20L4	<ul style="list-style-type: none"> Excellent short and long range performance High robustness and sensor diagnostics Advanced IO communication interface
E524.09 2 nd Generation Ultrasonic Transducer Driver and Signal Processor	6V to 18V	30kHz to 83kHz	pt-to-pt	transformer / 168mA to 354mA	10cm - 600cm	proprietary bidirectional IO (3-wire)	QFN20L4	<ul style="list-style-type: none"> Excellent short and long range performance High robustness and sensor diagnostics Advanced IO communication interface
E524.32 High Voltage Direct Drive Ultrasonic Sensor IC	6V to 18V	30kHz to 83kHz	pt-to-pt	direct drive	10cm - 400cm	proprietary bidirectional IO (2-wire)	QFN20L4	<ul style="list-style-type: none"> Best measurement performance without transformer High robustness and sensor diagnostics Near field detection
E524.33/34/35 High Voltage Direct Drive Ultrasonic Sensor IC	6V to 18V	30kHz to 83kHz	pt-to-pt	direct drive	10cm - 400cm	proprietary bidirectional IO (3-wire)	QFN20L4	<ul style="list-style-type: none"> Best measurement performance without transformer High robustness and sensor diagnostics Near field detection

LIN Bus (or pt-to-pt) Interface

Part No. / Description	V _{SUPPLY}	Transducer frequency	Architecture	Transducer driver type / output	Measurable Distance*	Interface	Package	Comment
E524.14 LIN Smart Ultrasonic Parking Assist (Flash)	8V to 18V	30kHz to 125kHz	Bus or pt-to-pt	transformer / 188mA to 518mA	15cm - 500cm	LIN 2.2	QFN20L5	<ul style="list-style-type: none"> Embedded, customer programmable controller LIN Interface supports SNPD and pin-coding
E524.24 LIN Smart Ultrasonic Parking Assist (ROM)	8V to 18V	30kHz to 125kHz	Bus or pt-to-pt	transformer / 188mA to 518mA	15cm - 500cm	LIN 2.2	QFN20L5	<ul style="list-style-type: none"> Optimized ready-to-use and flexible standard software Cost optimized ROM version of E524.14
E524.16 Smart Direct Drive 1 st Gen. with LIN Interface and 8bit Controller	7V to 24V	30kHz to 83kHz	Bus or pt-to-pt or ECU less	direct drive	10cm - 300cm	LIN 2.2	QFN20L5	<ul style="list-style-type: none"> Customer programmable controller System cost optimized direct drive solution Optional use in ECU less systems

* Reachable detection range for a standard pole (75mm diameter, 1m height).
Overall system performance depends on external components (transducer, transformer, PCB layout, ...) and environmental conditions (supply voltage, noise, ambient temperature, ...)

DSI3 (or pt-to-pt) Interface

Part No. / Description	V _{SUPPLY}	Transducer frequency	Architecture	Transducer driver type / output	Measurable Distance*	Interface	Package	Comment
E524.17 Smart Ultrasonic Sensor IC with DSI Interface	6V to 24V	30kHz to 125kHz	Bus or pt-to-pt	transformer / 190mA to 500mA	10cm - 600cm	DSI3	QFN20L5	<ul style="list-style-type: none"> ■ Ultrasound signal coding ■ Advanced DSI3 communication interface ■ High robustness and sensor diagnosis

* Reachable detection range for a standard pole (75mm diameter, 1m height).
Overall system performance depends on external components (transducer, transformer, PCB layout, ...) and environmental conditions (supply voltage, noise, ambient temperature, ...)

Master

Part No. / Description	Interface	V _{SUPPLY}	I _q (μA)	VDD	ESD (kV)	Bitrate	Package
E521.42 Dual Automotive DSI3 Master Transceiver	DSI3	7V to 20V	-	3.3V/5V	6	125kbit/s (master=>slave) up to 444kbit/s (slave to master)	QFN20L4

2nd Gen. Ultrasonic Transducer Driver and Signal Processor | E524.08/09

Key Features

- Drives ultrasonic transducer via center-tapped transformer
- Excellent short & long range performance due to:
 - Wide signal gain range / Sensitivity time control / Static and automatic thresholds / Near-field threshold / Echo peak detection / Fast time constant algorithm
- Advanced IO protocol with configurable measurement profiles
- IC and transducer diagnosis information
- E524.08: 2-wire Interface
- E524.09: 3-wire Interface

Board

- Order No. see page 28



Applications

- Ultrasonic park assist (USPA/PDS/UPA)
 - Automatic parking (SPAS/APA)
 - Advanced driver assistance systems (ADAS)
 - Industrial distance measurement

Packages

- QFN20L4

Application Diagram

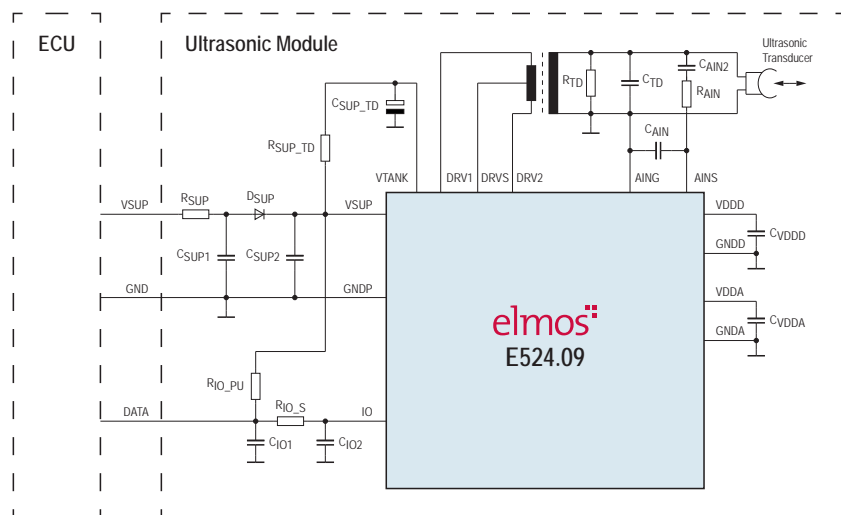

High Voltage Direct Drive Ultrasonic Sensor IC | E524.32/33/34/35

Key Features

- Supports directly driven transducers
- Best measurement performance due to:
 - Smart damping algorithm / Two static and one automatic thresholds / Near field detection / Noise suppression
- High robustness and diagnostics
- Transducer diagnosis information / Temperature sensor
- Advanced IO protocol with configurable measurement profiles
- E524.32: 2-wire Interface | E524.33: 3-wire Interface | E524.34: 3-wire Interface 3.3V | E524.35: 3-wire Interface 5.0V

Board

- Order No. see page 28



Applications

- Ultrasonic park assist (USPA/PDS/UPA)
 - Automatic parking (SPAS/APA)
 - Industrial distance measurement

Packages

- QFN20L4

Application Diagram

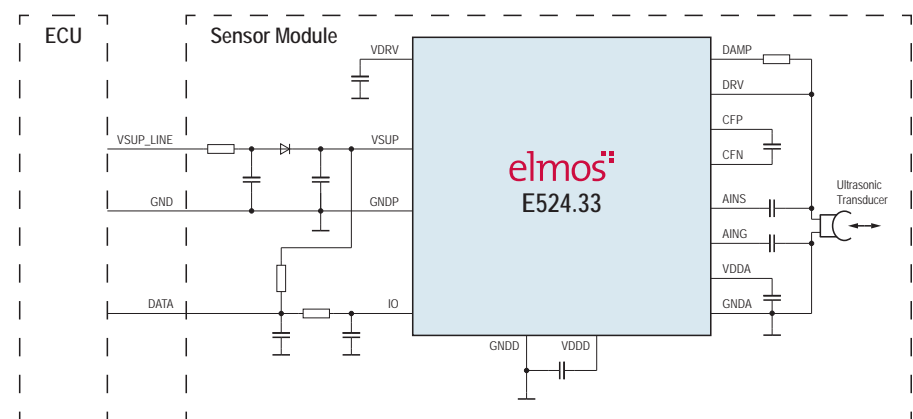

LIN Smart Ultrasonic Parking Assist (Flash/ROM) | E524.14/24

Key Features

- Drives ultrasonic transducer via center-tapped transformer
- Good measurement performance due to flexible software
- IC and transducer diagnosis information
- Embedded 8bit microcontroller with 8kByte Flash or ROM / 512Byte SRAM / 128Byte EEPROM
- LIN 2.2 Interface with slave node position detection (SNPD) and alternative pin-coding capabilities
- E524.14: User programmable Flash memory
- E524.24: Ready-to-use and flexible standard software (ROM)

Board

- Order No. see page 28



Applications

- Ultrasonic park assist (USPA/PDS/UPA)
 - Automatic parking (SPAS/APA)
 - Advanced driver assistance systems (ADAS)
 - Distance and level metering

Packages

- QFN20L5

Application Diagram

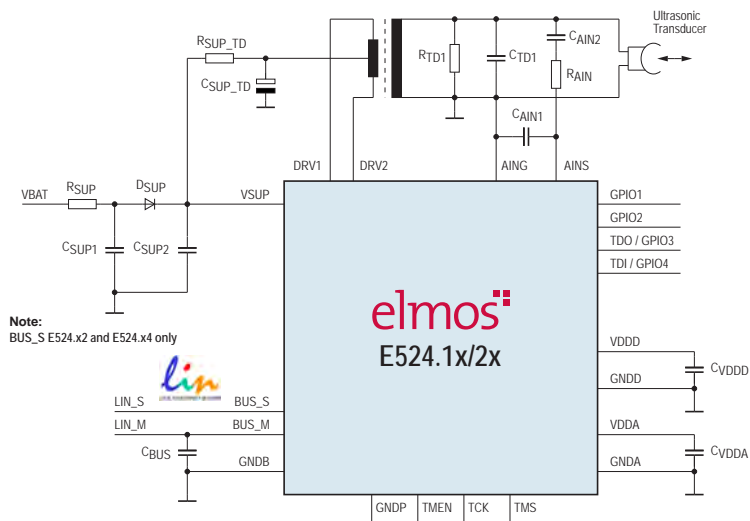

Direct Drive Smart LIN Ultrasonic Sensor IC | E524.16

Key Features

- Supports directly driven transducers
- Best measurement performance due to:
 - Static and automatic thresholds / Near-field detection / Noise suppression
- IC and transducer diagnosis information
- Embedded 8bit microcontroller with 16kByte OTP / 1024Byte SRAM / 256Byte EEPROM
- LIN 2.2 Interface with slave node position detection (SNPD)
- 4 High-voltage GPIOs for ECU less parking systems

Board

- Order No. see page 28



Applications

- Ultrasonic park assist (USPA/PDS/UPA)
- ECU-less low cost systems
 - Industrial distance measurement

Packages

- QFN20L5

Application Diagram

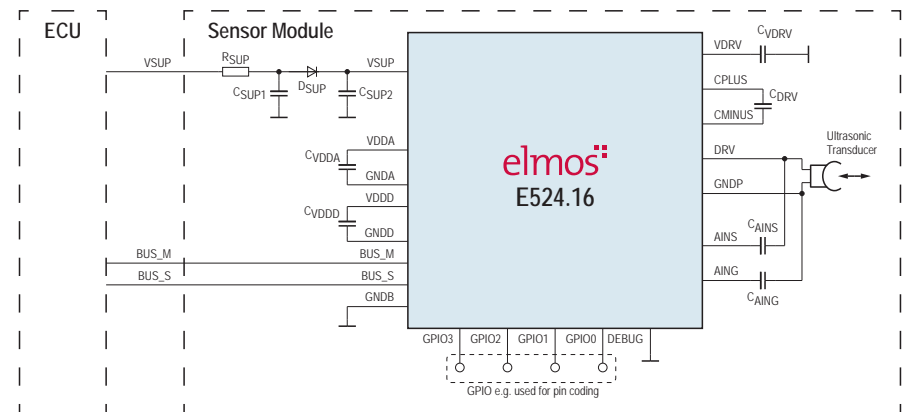

Smart Ultrasonic Sensor IC with DSI Interface | E524.17

Key Features

- Outstanding performance
 - Advanced analog & digital signal processing
 - Ultrasound signal coding / Adaptive thresholds
- High robustness and good diagnostics
 - Ringing time and ringing frequency measurement
 - Self-test capabilities / Impedance measurement
- Flexible high-speed DSI3 communication interface
- ISO26262 with safety requirements rated up to ASIL B
- Arm® Cortex®-M0 with 32kB OTP | 4kB SRAM | 256 Byte EEPROM

Board

- Order No. see page 28



Applications

- Ultrasonic park assist (USPA/PDS/UPA)
 - Automatic parking (SPAS/APA)
 - Advanced driver assistance systems (ADAS)

Packages

- QFN20L5

Application Diagram

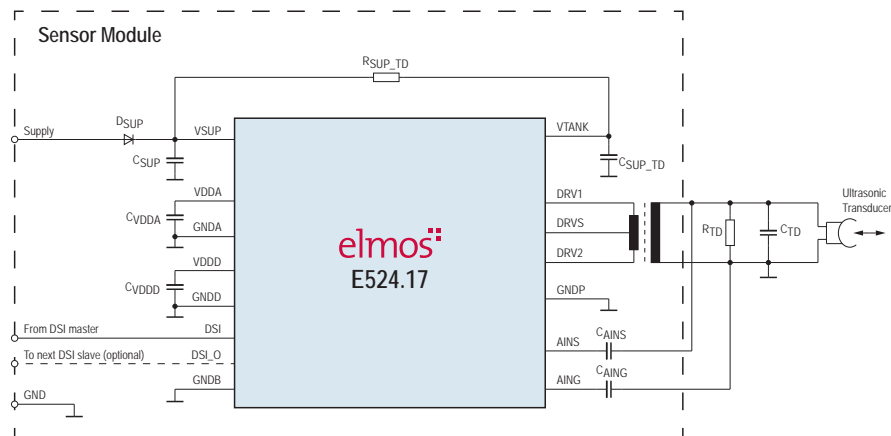

Dual Automotive DSI3 Master Transceiver | E521.42

Key Features

- Suitable for fast data acquisition of sensors in signal function class
- Supports:
 - Point-to-point/ Daisy chain bus/ Parallel bus
- Versatile in-circuit configuration:
 - up to 15 DSI3-slaves
 - up to 16 packets per frame
 - 2 .. 63 bytes of average payload data per packet
- ISO26262 with safety requirements rated up to ASIL B

Board

- Order No. see page 28



Applications

- Ultra sonic parking assistant system
- DSI3 bus networks

Packages

- QFN20L4

Application Diagram

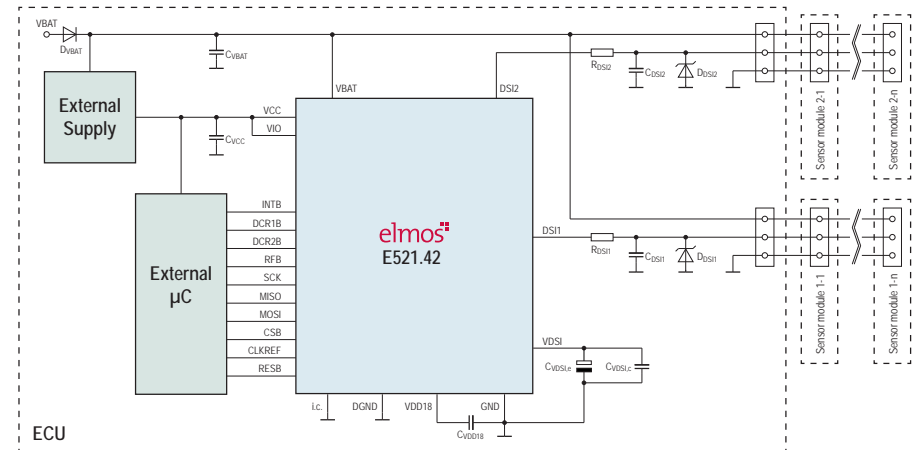

Sensors - Ultrasonic Product Portfolio

IO pt-to-pt Interface

- Proprietary (1 level) interface
- Most signal evaluation in Park ECU

LIN BUS (or pt-to-pt) Interface

- LIN Bus System with less wiring
- Signal pre conditioning in sensor
- Potentially without Park ECU or ECU less



DSI3 BUS (or pt-to-pt) Interface

- High bandwidth (up to 444kbit/s)
- Low latency time for fast system reaction
- Direct integration into ADAS systems



Sensor-IC
Transformer Driven



E524.08/09
Transformer Drive 2nd Gen.
with advanced IO Interface
(10cm – 600cm)



E524.14/24
Smart Transformer Drive 1st Gen.
with LIN Interface and 8bit Controller
(Flash and ROM versions)
(15cm – 500cm)



E524.17
Smart Transformer Drive 1st Gen.
with DSI3 Interface and 32bit μ C
ISO26262-ASIL B
(10cm – 600cm)

Sensor-IC
Direct Driven



E524.32/33/34/35
Direct Drive 2nd Gen.
with advanced IO Interface
(10cm – 400cm)



E524.16
Smart Direct Drive 1st Gen.
with LIN Interface and 8bit Controller
(10cm – 300cm)

Master-IC



E521.42
Master IC
2ch DSI3 Transceiver for
DSI3 Bus Systems
ISO26262-ASIL B

Sensors - SSP: Sensor Signal Processor for Resistive Bridges

Part No. / Description	V _{SUPPLY}	Output	Range	Package	Comment
E520.42 Automotive SSP with Analog or Sent Output	5V ±0.5V	5V Ratiometric Voltage SENT interface	Sensor Sensitivity 0.8mV/V to 50mV/V	QFN20L4 Bare-Die	<ul style="list-style-type: none"> Automotive protection +40/-28V Very low noise front-end Trimable input low-pass filter Comprehensive self diagnostics SENT interface (SAE J2716, Jan 2010)
E520.47 Dual-Bridge Sensor Signal Processor with SENT Interface	5V ±0.25V	SENT or I ² C	Sensor Sensitivity 3mV/V to 56mV/V	QFN20L4 Bare-Die	<ul style="list-style-type: none"> Automotive protection +35/-18V Two fully redundant sensor bridge inputs ISO26262 development for ASIL C support Configurable SENT interface AECQ-100 qualified
E703.11 Sensor Signal Processor for High Precision Applications	2.7V to 5.5V	SPI or I ² C with CRC, Analog voltage, PWM or FM, End of Conversion/Alarm	Sensor Sensitivity 2mV/V to 88mV/V	DFN14_3x4 Bare-Die	<ul style="list-style-type: none"> Developed for Industrial Applications Precision front end with two 16-bit ADC's Configurable sample rate (2..50kS/s) and low pass filter (10Hz..8kHz) 3rd order polynomial sensor correction Sleep mode available (I<20μA)
E703.21 Sensor Signal Processor for Industrial Pressure Transmitter	4.75V to 32V	4 .. 20mA Current Loop 0..5V/10V Absolute Voltage 5V Ratiometric Voltage	Sensor Sensitivity 2mV/V to 88mV/V	DFN14_3x4	<ul style="list-style-type: none"> Developed for Industrial Applications Precision front end with two 16-bit ADC's Sensor Calibration via Output Pins Precise current sense shunt Integrated voltage regulator

Automotive SSP with Analog or Sent Output | E520.42

Key Features

- Very low noise front-end amplifier and ADC allows SNR > 70dB for inputs down to 1mV/V FS
- PGA configurable to 50mV/V FS and adjustable offset of $\pm 150\%$ FS
- Digital compensation of offset- and gain-drift and non-linearity up to 3rd order
- Analog voltage or digital SENT output (SAE J2716, JAN2010)
- Supply $5.0 \pm 0.5V$, over-voltage a. reverse polarity protection (28V)
- Single-wire programming interface

Board

- Order No. see page 28



Applications

- Automotive sensor applications
- Conditioning of resistive bridge sensors

Packages

- QFN20L4
- Bare-Die

Application Diagram

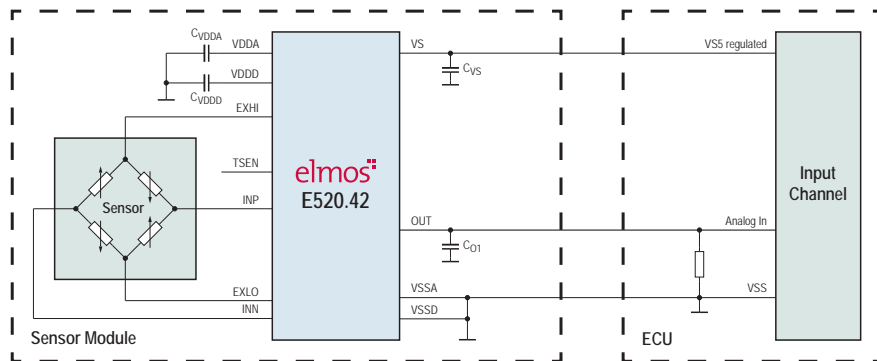

Dual-Bridge Sensor Signal Processor with SENT Interface | E520.47

Key Features

- Supply and output protection: -18/+35 V
- Simultaneous signal processing for two sensors
- Fully digital calibration; no external trim components
- 10-step coarse gain trimming
- Low noise input with 15-bit ADC
- Configurable digital low-pass: 13Hz .. 1.1kHz
- Additional NTC channel with on-chip linearization
- ISO26262 development with safety requirements rated up to ASIL C

Board

- Order No. see page 28



Applications

- Automotive sensor applications
- Functional Safety Sensors, e.g. braking systems
- Conditioning of resistive bridge sensors

Packages

- QFN20L4
- Bare-Die

Application Diagram

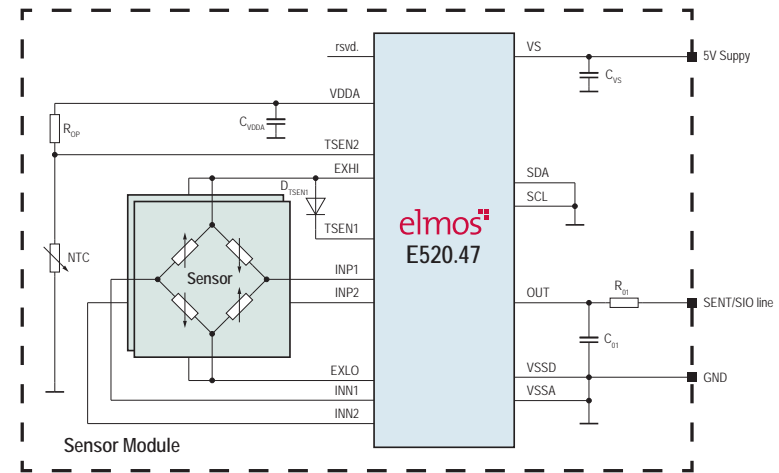

Sensor Signal Processor for High Precision Applications | E703.11

Key Features

- High precision frontend
- PGA configurable to 2 .. 88mV/V FS, offset adjustable to $\pm 300\%$ FS
- Output signal bandwidth widely configurable: (10Hz .. 8kHz), accuracy (10 .. 15 ENOB) and sample rate (2 .. 50kS/s)
- Ultra low latency: output update rate 2 .. 50kS/s, DSP time < 25 μ s
- 6th order polynomial sensor correction (16 coefficients)
- Temperature sources: chip, bridge and external (diode, NTC)

Board

- Order No. see page 28



Applications

- High precision industrial pressure sensors
- Ultra low pressure OEM modules
- Industrial products using resistive sensor bridges

Packages

- DFN14_3x4
- Bare-Die

Application Diagram

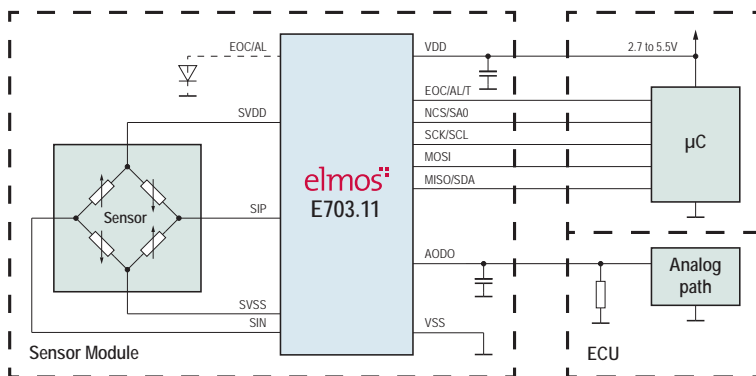

Sensor Signal Processor for Industrial Pressure Transmitter | E703.21

Key Features

- Pressure signal bandwidth, accuracy and output update rate widely configurable
- Two fully differential 16 bit ADCs for pressure and temperature signal acquisition
- Configurable 4 .. 20mA / absolute 0 .. 10V / ratiometric 0 .. 5 V analog output with 16 bit DAC
- Ultra low latency, limited only by -3dB signal bandwidth
- Traceability by unique 48bit serial number

Board

- Order No. see page 28



Applications

- Industrial pressure transmitters
- Resistive MEMS & thick/thin film sensors with and without laser trimmed offset (offset up to 36 .. 114 mV/V)

Packages

- DFN14_3x4

Application Diagram

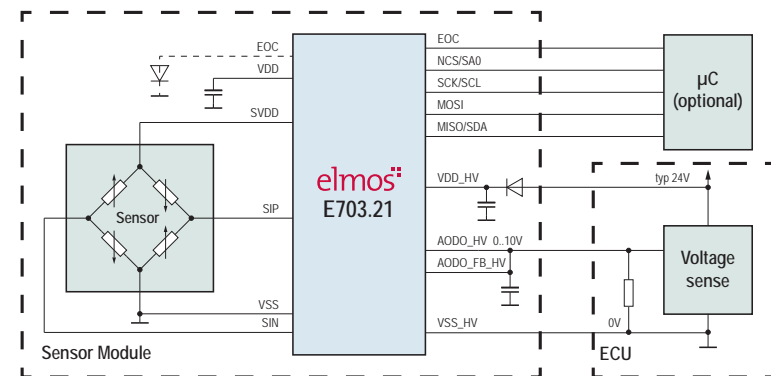

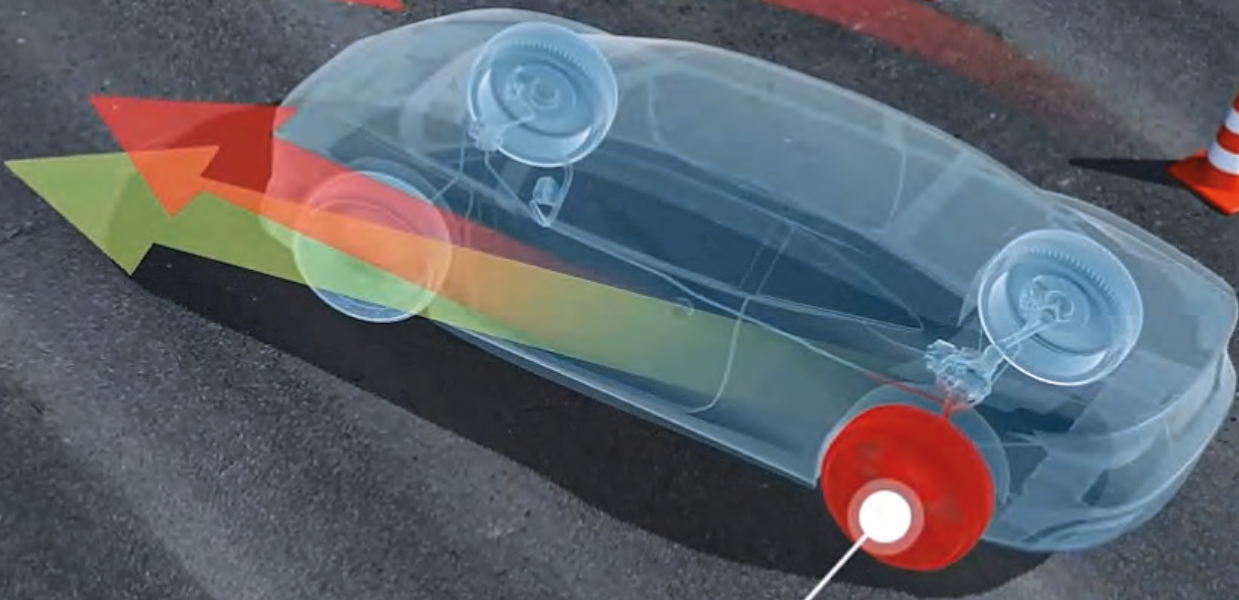

ESC Correction: **Apply brake pressure**

Sensors - IAPS: Integrated Absolute Pressure System

Part No. / Description	V _{SUPPLY}	Output	Pressure Range	Package	Comment
E524.71 Barometric Air Pressure Sensor with SPI Interface	3V to 5.5V	SPI	40kPa to 115kPa	SOIC8	<ul style="list-style-type: none"> ■ Fully Calibrated up to 1% FS ■ Very Small Footprint (6 x 5 mm²) ■ Application Range -40°C to +125°C ■ Temperature and diagnostic data via digital interface available ■ AECQ qualified
E524.72 Barometric Air Pressure Sensor with I ² C Interface	3V to 5.5V	I ² C	40kPa to 180kPa	SOIC8	<ul style="list-style-type: none"> ■ Fully Calibrated up to 1% FS ■ Very Small Footprint (6 x 5 mm²) ■ Application Range -40°C to +125°C ■ Temperature and diagnostic data via digital interface available ■ AECQ qualified
E524.73 Barometric Air Pressure Sensor with Analog Output	5V ±0.5V	5V Ratiometric Voltage	15kPa to 115kPa or 60kPa to 165kPa	SOIC8	<ul style="list-style-type: none"> ■ Fully Calibrated up to 1% FS ■ Very Small Footprint (6 x 5 mm²) ■ Application Range -40°C to +125°C ■ AECQ qualified
E524.75 Integrated Absolute Pressure Sensor with Analog Output	5V ±0.5V	5V Ratiometric Voltage	10kPa to 115kPa	SOIC20	<ul style="list-style-type: none"> ■ Integrated over-and reverse voltage protection ■ Superior EMC performance ■ Application Range -40°C to +130°C ■ AECQ qualified

Barometric Air Pressure Sensor | E524.71/72/73

Key Features

- Fully integrated pressure sensor
- Full thermal compensation to accuracy ± 1.0 kPa
- Two 16-bit ADCs for acquisition of pressure and temperature inputs; pressure acquired at 20kS/s
- Diagnosis of sensor, sensor supply and wiring, and NVM check-sum supervision at power-on

Board

- Order No. see page 29



Applications

- Automotive applications
- Industrial applications
- Medical applications

Packages

- SOIC8

Application Diagram

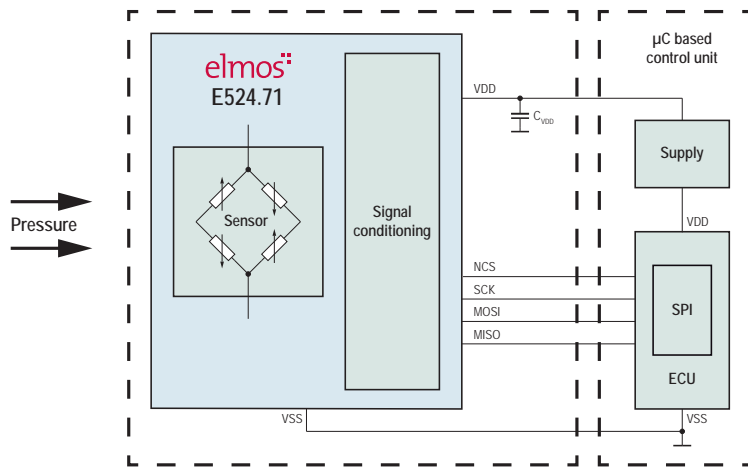

Integrated Absolute Pressure Sensor with Analog Output | E524.75

Key Features

- Fully integrated and compensated pressure sensor
- Different measurement ranges of absolute pressure available
- 10 to 115kPa with clipping of output
- Full thermal compensation to accuracy ± 2 %FS
- Ratiometric analog output
- Wide linear range of analog output
- Diagnosis of sensor, sensor supply wiring, and NVM CRC check at power-on



Applications

- Automotive Pressure Sensor
- Manifold Absolute Pressure Sensing

Packages

- SOIC20

Application Diagram

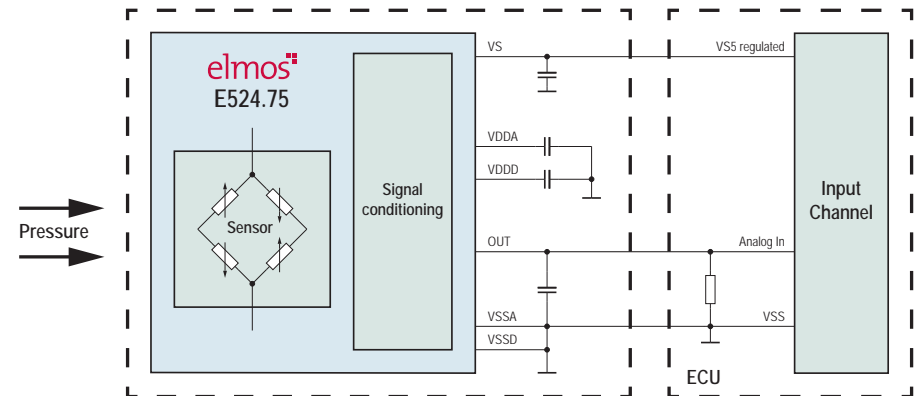

Sensors - Optical IR Sensor (HALIOS®)

Rain and Light

Part No. / Description	V _{SUPPLY}	I _q	Functionality	Package	Comment
E527.04 Rain and Light Sensor	3.1V to 3.5V	4.7mA (typical)** 8µA (sleep mode)	Rain sensing Ambient light measurement	QFN20L4	<ul style="list-style-type: none"> ■ Rain-Light sensor signal processor ■ Built-in sunlight rejection ■ Two rain channels and ambient light channels ■ SPI interface ■ Internal diagnosis ■ Integrated temperature sensor

Proximity and Gesture

Part No. / Description	V _{SUPPLY}	I _q	Functionality	Package	Comment
E909.21 HALIOS® Controller for Proximity and Gesture Recognition	3V to 3.6V	15mA (typical)*	Proximity detection 1 .. 3 dimensional input devices Touch	QFN32L5	<ul style="list-style-type: none"> ■ 16 Bit µC with flash, SPI and I²C Interface ■ Two independent receiving channels ■ Real time measurement results for rapid gesture detection ■ 100mA LED output per channel ■ Extrinsic light measurement
E909.22 HALIOS® Signal Conditioner for Proximity and Gesture Recognition	2.2V to 3.6V	9mA (typical)*	Proximity detection 1 .. 3 dimensional input devices Touch	QFN20L4	<ul style="list-style-type: none"> ■ Companion chip for E909.21 ■ Two independent receiving channels ■ Real time measurement results for rapid gesture detection ■ 100mA LED output per channel ■ Extrinsic light measurement
E909.23 HALIOS® Low Power Signal Conditioner	2.2V to 3.6V	9mA (typical)* <150µA (idle mode) <1.5µA (sleep mode)	Proximity detection 1 .. 3 dimensional input devices Touch	QFN20L4	<ul style="list-style-type: none"> ■ One receiving channel ■ Real time measurement results for rapid gesture detection ■ 100mA LED output channel ■ Extrinsic light measurement

* Without LED current and photo diode current

** Without LED current

Consumer

Part No. / Description	V _{SUPPLY}	I _q	Functionality	Package	Comment
E527.16 HALIOS® Gesture Switch	2.25V to 2.75V 3.0V to 3.6V	4mA (typical)	Proximity Awareness Acknowledge	QFN32L5	<ul style="list-style-type: none">■ Advanced ready-to-use function■ Implemented gesture recognition■ PWM-Output for innovative motion-controlled lighting application

Rain and Light Sensor | E527.04

Key Features

- Front end Optical Rain Sensor signal processor
- Four input channels for ambient light measurements
- High sensitivity, no total reflection needed
- Very high robustness against ambient influences like sun light, aging and dirt
- Two embedded LED drivers, driving up to 40mA
- Provides a rain drop signal via the WS pin - SPI interface
- Temperature sensor
- Extensive diagnosis during operation

Board

- Order No. see page 29



Applications

- Optical Rain Sensor (wiping systems)
 - Windshield, Security Cameras
- Ambient Light Sensor (measurement) to control
 - Headlight, Head-up Displays, Air Conditioning
- Pollution Sensor

Packages

- QFN20L4

Application Diagram

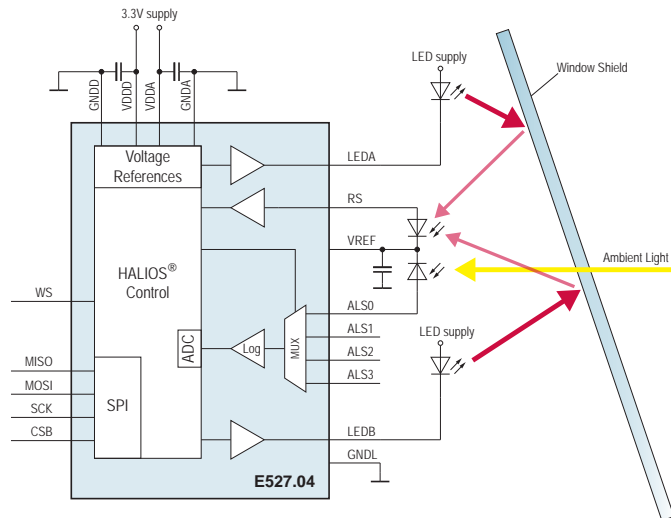

HALIOS® Controller for Proximity and Gesture Recognition | E909.21

Key Features

- Patented HALIOS® control loop
- 4 LED sending channels, 100mA per channel
- 2 receiving channels, 1 compensator channel
- Scalable HALIOS® frequency up to 1MHz
- SSI serial sensor interface
- 16 bit Harvard Architecture H430 CPU
- 32kByte Flash, 4kByte SRAM and 8kByte SysROM
- Temperature range -40°C to +105°C
- Automotive qualified (AEC-Q100)

Board

- Order No. see page 29



Applications

- Proximity a. gesture recognition for automotive touch displays
- Driver and passenger detection
- Wake-up function for displays
- Touchless control in harsh environments (e.g. explosion protected areas)

Packages

- QFN32L5

Application Diagram

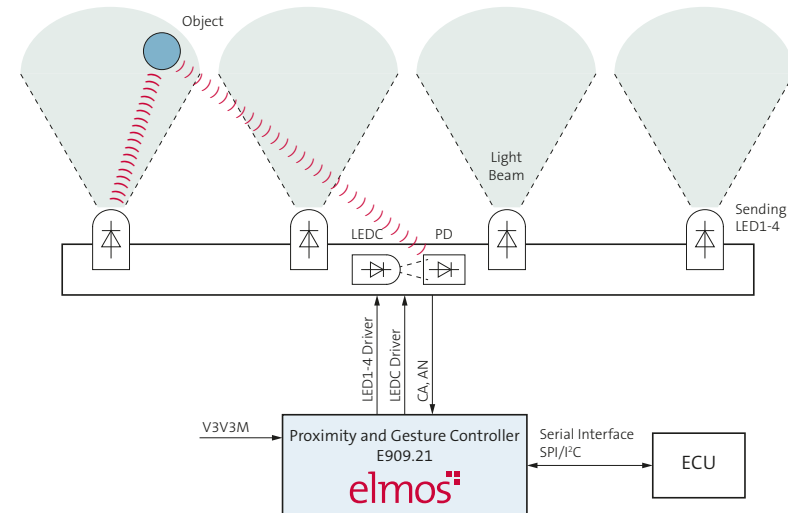

HALIOS® Signal Conditioner f. Proximity a. Gesture Recognition | E909.22

Key Features

- Patented HALIOS® control loop
- 4 LED sending channels, 100mA per channel
- 2 receiving channels
- 1 compensator channel
- Scalable HALIOS® frequency up to 1MHz
- SSI serial sensor interface
- Ambient light immunity up to 200.000 lux
- Temperature range -40°C to +105°C
- Automotive qualified (AEC-Q100)

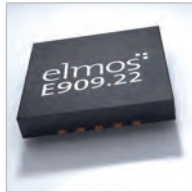

Applications

- Proximity a. gesture recognition for automotive touch displays
- Driver and passenger detection
- Wake-up function for displays
- Touchless control in harsh environments (e.g. explosion protected areas)

Packages

- QFN20L4

Application Diagram

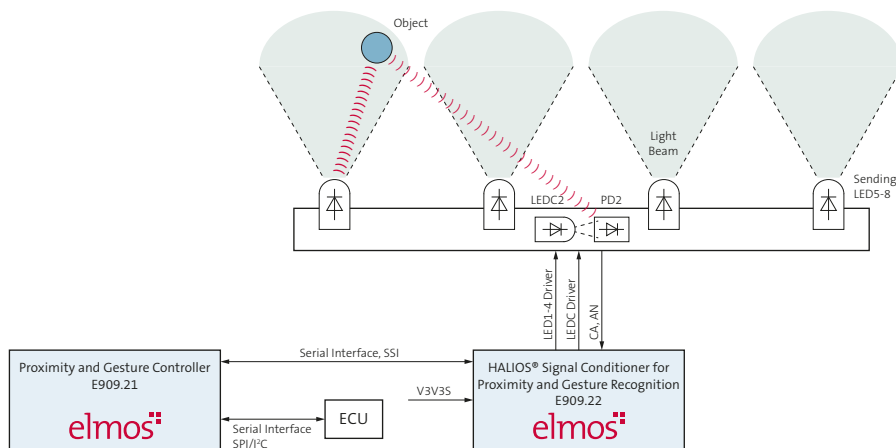

HALIOS® Low Power Signal Conditioner | E909.23

Key Features

- Patented HALIOS® control loop
- 4 LED sending channels, 100mA per channel
- 1 receiving channels
- 1 compensator channel
- I²C interface
- Ambient light immunity up to 200.000 lux
- Temperature range -40°C to +105°C
- Automotive qualified (AEC-Q100)



Applications

- Wide Sensor Bars
- Door Handles
- Control Panels
- Focal point of Interest

Packages

- QFN20L4

Application Diagram

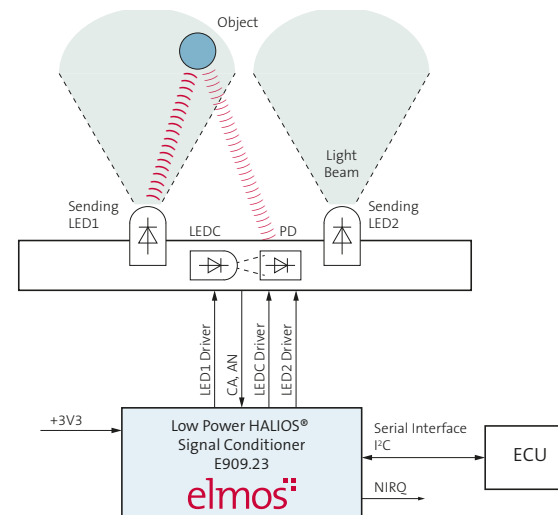

HALIOS® Gesture Switch | E527.16

Key Features

- Ready-to-use functions
- Implemented gesture recognition
- Detection approx. 25cm
- Direct light control possible
- PWM-Output (125 Hz, 8 Bit)
- Reference schematics and reference layout are available

Board

- Order No. see page 29



Applications

- Innovative motion controlled light
- Optical push buttons and controls
- Wake-up function for saving energy
- Pre-selection to simplify menu structures

Packages

- QFN32L5

Application Diagram

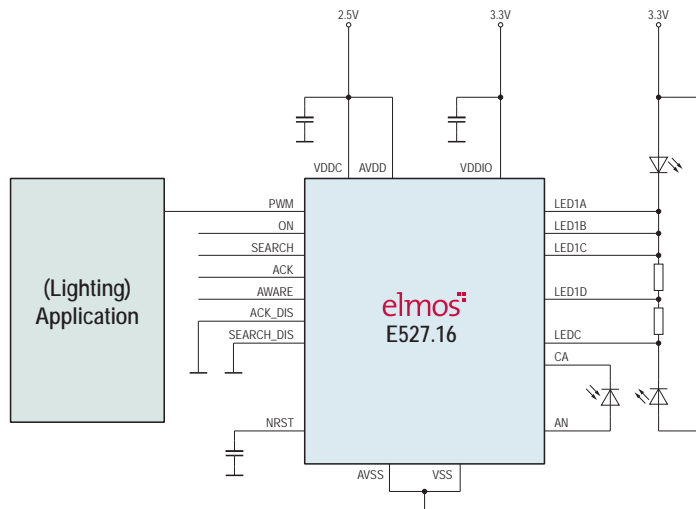



HALIOS® - Proximity and
Gesture Recognition

Sensors - ToF Imager

Part No. / Description	V _{SUPPLY}	I _q	Functionality	Package	Comment
E527.31 3D Image Sensor	4.75V to 5.25V	2.6mA (typical) 14µA (sleep mode)	Absolute distance measurement	QFN44L7	<ul style="list-style-type: none">■ Gesture and object recognition■ Dedicated for distance measurements■ Ambient light suppression■ SPI Interface

3D Image Sensor | E527.31

Key Features

- Optical sensor for gesture and object recognition
- 32 x 32 active pixels
- 3D information enables object classification in real time
- Ambient light suppression by 850nm bandpass filter and background light subtraction
- Very low power consumption
- Integrated temperature sensor for temperature compensation
- Automotive qualified (AEC-Q100)

Board

- Order No. see page 29



Applications

- Finger gesture detection in HMI applications
- Passenger monitoring
- Easy open liftgate
- Contactless door access

Packages

- QFN44L7

Application Diagram

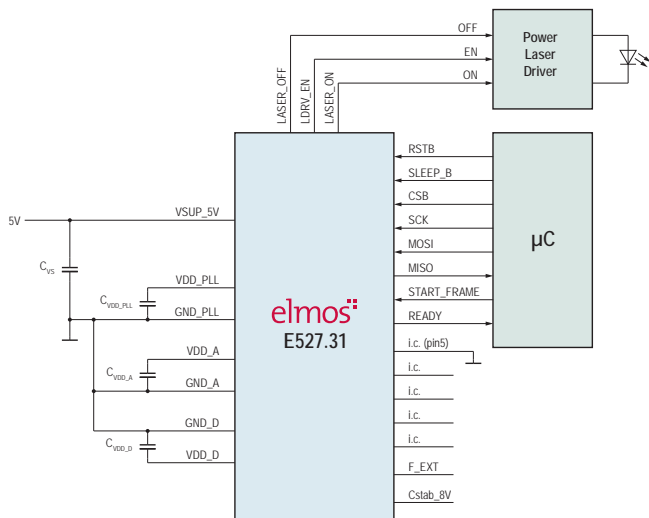

Sensors - Passive Infrared Sensors

Pyroelectric Sensor Signal Processor (SSP)

Part No. / Description	V _{SUPPLY}	I _{SUPPLY}	Output	Package	Comment
E931.06 Pyroelectric SSP	2.7V to 3.6V	15μA	PIR Signal and Temperature (DOCI™)	Wafer Bare-Die	<ul style="list-style-type: none"> Digital signal processing Single wire interface (DOCI™)
E931.62 Dual Channel Pyroelectric SSP	2.7V to 3.6V	18μA	PIR Signal and Temperature (DOCI™)	Wafer Bare-Die	<ul style="list-style-type: none"> Dual channel Digital signal processing Single wire interface (DOCI™)
E931.96 Low Power Pyroelectric SSP	2.5V to 3.6V	6μA	Motion DETECT, Supply voltage for PIR Detector	SOIC8 Wafer Bare-Die	<ul style="list-style-type: none"> Ultra low power consumption Excellent power supply rejection Programmable detection criteria and operating modes

Pyroelectric Sensor Signal Controller (SSC)

Part No. / Description	V _{SUPPLY}	I _{SUPPLY}	Output	Package	Comment
E910.97 Pyroelectric SSC with Relay Output	2.7V to 3.6V	15μA	PIR Signal, digital	Wafer Bare-Die	<ul style="list-style-type: none"> Outputs for motion detect Insensitive to RF interference Inputs for sensitivity and on time
E931.97 Pyroelectric SSC with Relay/LED Output	2.7V to 3.6V	25μA	Motion DETECT, Threshold	SOIC14N TSSOP14 Wafer Bare-Die	<ul style="list-style-type: none"> Outputs for relay and LED Insensitive to RF interference Instantaneous settling after power up
E931.98 Pyroelectric SSC with Zero Crossing Detection	2.7V to 3.6V	18μA	Motion DETECT, Threshold	SOIC14N TSSOP14	<ul style="list-style-type: none"> Insensitive to RF interference Instantaneous settling after power up Adaptive mains zero cross switching

Pyroelectric SSP | E931.06

Key Features

- Direct connection to PIR sensor elements
- Temperature measurement
- Differential PIR sensor input
- Low Current Consumption
- Excellent power supply rejection
- High dynamic range

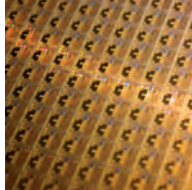

Applications

- Integration with PIR sensor elements
- High end PIR systems
- Building management

Packages

- Wafer
- Bare-Die

Application Diagram

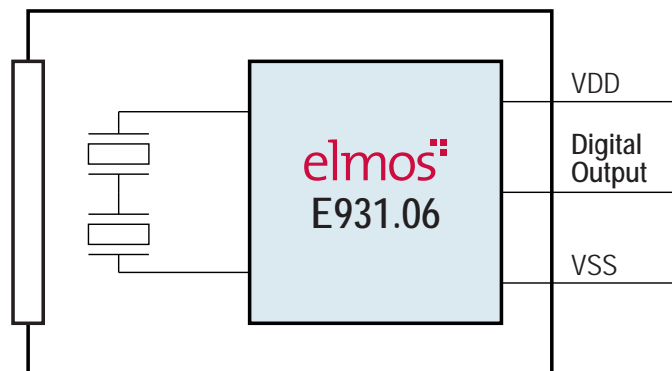

Dual Channel Pyroelectric SSP | E931.62

Key Features

- Direct connection to PIR sensor elements
- Temperature measurement
- Differential PIR inputs
- Digital Signal Processing (DSP)
- Single wire serial interface (DOC1™)
- Operating voltage down to 2.7V
- Low current consumption
- High dynamic range
- High supply rejection

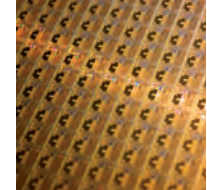

Applications

- Integration with PIR sensor elements (hybrid modules)
- Gas sensors
- High end PIR systems

Packages

- Wafer
- Bare-Die

Application Diagram

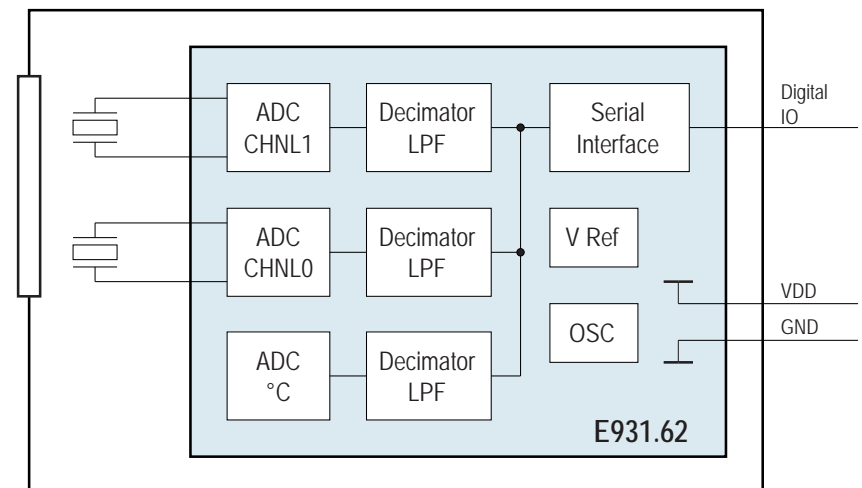

Low Power Pyroelectric SSP | E931.96

Key Features

- Programmable detection criteria and operating modes
- Digital signal processing
- On chip supply regulator for conventional PIR detectors
- Ultra low power consumption
- Differential PIR sensor input
- Excellent power supply rejection
- Insensitive to RF interference
- Instantaneous settling after power up

Board

- Order No. see page 29



Applications

- Wireless intruder detectors
- Battery powered door chimes
- Emergency lighting
- Motion and presence detection

Packages

- SOIC8
- Wafer
- Bare-Die

Application Diagram

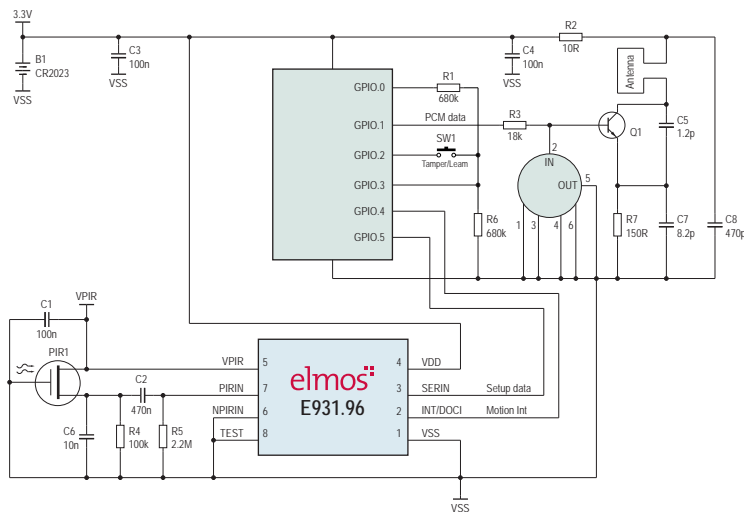

Pyroelectric SSC with Relay Output | E910.97

Key Features

- Digital Signal Processing
- On chip shunt regulator
- Low Power Consumption
- Differential PIR sensor input
- Excellent power supply rejection
- Inputs for sensitivity and on time

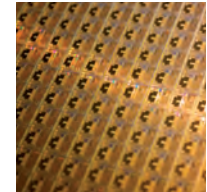

Applications

- PIR motion detection
- Intruder detection
- Occupancy detection
- Motion sensor lights

Packages

- Wafer
- Bare-Die

Application Diagram

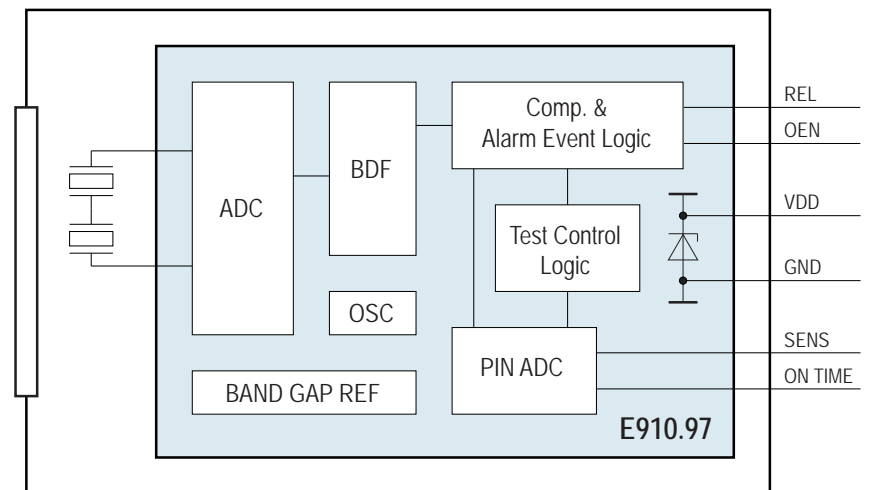

Pyroelectric SSC with Relay/LED Output | E931.97

Key Features

- Digital Signal Processing
- On chip shunt regulator
- Low Power Consumption
- Differential PIR sensor input
- Excellent power supply rejection
- Outputs for relay and LED



Applications

- PIR motion detection
- Intruder detection
- Occupancy detection
- Motion sensor lights

Packages

- SOIC14N
- TSSOP14
- Wafer
- Bare-Die

Application Diagram

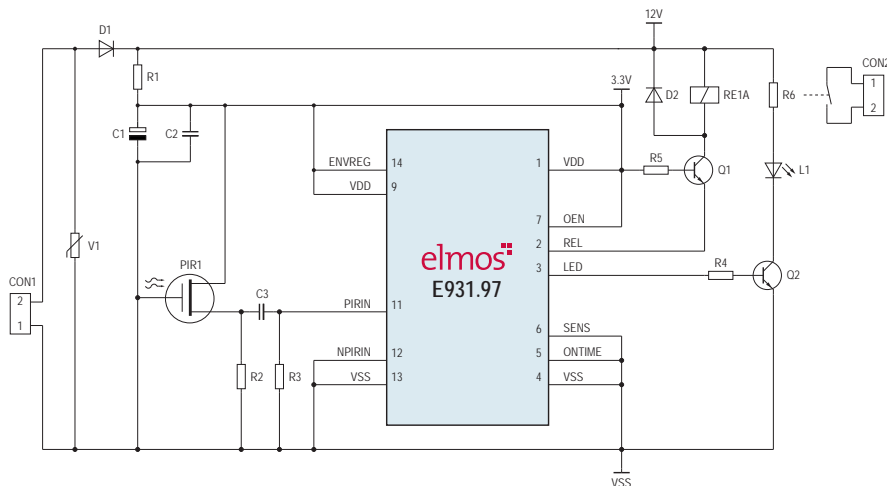

Pyroelectric SSC with Zero Crossing Detection | E931.98

Key Features

- One pulse trigger
- Adaptive zero crossing switching
- On chip shunt regulator
- Low power consumption
- Differential PIR sensor input
- Excellent power supply rejection



Applications

- PIR motion detection
- Intruder detection
- Occupancy detection
- Motion sensor lights

Packages

- SOIC14N
- TSSOP14

Application Diagram

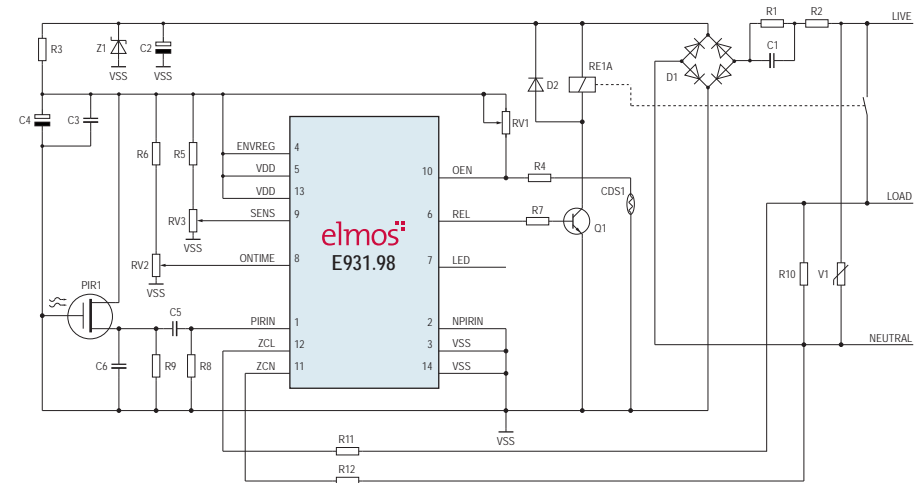

Sensors - Boards

Ultrasonic

Part No.	Description	Board type	Order No.
E524.08	Ultrasonic Sensor Application Board	Demoboard	K52408-0001
E524.09	Ultrasonic Sensor Application Board	Demoboard	K52409-0001
E524.14	Ultrasonic Demonstration Kit (Board + LIN Adapter + Docu)	Evaluation Kit	K52414-0001
E524.14	Ultrasonic Sensor Application Board	Demoboard	K52414-0003
E524.16	Ultrasonic Sensor Socket Board	Evaluationboard	K52416-0001
E524.17	Ultrasonic Sensor Socket Board	Evaluationboard	K52417-0002
E524.17	Ultrasonic Sensor Application Board	Demoboard	K52417-0003
E524.24	Ultrasonic Demonstration Kit (Board + LIN Adapter + Docu)	Evaluation Kit	K52424-0001
E524.24	Ultrasonic Sensor Application Board	Demoboard	K52424-0002
E524.32	Ultrasonic Sensor Application Board	Demoboard	K52432-0001
E524.33	Ultrasonic Sensor Application Board	Demoboard	K52433-0001
E524.0X	Ultrasonic IO Master Board (Board + Adapter + Docu)	Demoboard	K5240X-0001
E521.42	Ultrasonic DSI3 Master Board (Board + Adapter + Docu)	Demoboard	K52142-0002

SSP: Sensor Signal Processor for Resistive Bridges

Part No.	Description	Board type	Order No.
E520.42	SSP2 Board + Adapter	Evaluation Kit	K52042-0001
E520.47	SSP2 Board + Adapter	Evaluation Kit	K52047-0001
E703.11	SSP3 Board + Adapter	Evaluation Kit	K70311-0001
E703.11	Multi Sensor Calibration	Evaluation Kit	K70311-0002
E703.21	SSP3 Board + Adapter	Evaluation Kit	K70321-0001
E703.21	Multi Sensor Calibration	Evaluation Kit	K70321-0002

IAPS: Integrated Absolute Pressure System

Part No.	Description	Board type	Order No.
E524.71	Application Circuit Board	Demoboard	K52471-0001
E524.72	Application Circuit Board	Demoboard	K52472-0001
E524.73	Application Circuit Board	Demoboard	K52473-0001

HALIOS®

Part No.	Description	Board type	Order No.
E527.04	Rain Sensing Evaluation Kit	Evaluation Kit	KI 1210005
E527.16	HALIOS® Reference Board	Demoboard	RD 1210001
E909.21	10 inch Bottom G2 Evaluation Kit	Evaluation Kit	M141 or M142
E909.21/22	10inch Bottom G2 Reference Design Package	Reference Design	M1003D
E909.21/22	13 inch Bottom G2 Evaluation Kit	Evaluation Kit	M143
E909.21/22	15inch Bottom G2 Evaluation Kit	Evaluation Kit	M144
E909.21	Mini ComBoard-03	Accessory	M1006
E909.21	MAZ JTAG Adapter-00	Accessory	M1007

ToF Imager

Part No.	Description	Board type	Order No.
E527.31	GDE ToF Evaluation Kit (850nm)	Evaluation Kit	K52731-0002

Pyroelectric Sensor Signal Processor (SSP)

Part No.	Description	Board type	Order No.
E931.96	Motion Sensing, Ultra Low Power PIR controller, Evaluation Module	Demoboard	K93196-0001

Motor Control - Stepper Motor

Part No. / Function	V _{SUPPLY}	I _{PEAK}	P(Motor)peak	RDS _{ON}	Interface	Package	Comment
E523.30 *SoC Power Stepper Controller with Stall Detection with/without Auto-Addressing (LIN/PWM Interface)	5.5V to 20V (42V)	2 channel	≈25W	550mΩ (HS) 450mΩ (LS)	<ul style="list-style-type: none"> ■ LIN 2.x (1.3 comp.) or SAE-J2602 or PWM Interface Optional LIN Auto-Addressing (SNPD) only E523.30 or LIN Flash update ■ JTAG 	QFN32L6	<ul style="list-style-type: none"> ■ Current chopper motor control ■ Supply and read-out of up to 3 sensors ■ Embedded 8bit μC ■ 8k Flash ■ T_{Junc} peak = +170°C
E523.31 *Plug & Play Power Stepper Controller with Stall Detection with standard application software (LIN Interface)	5.5V to 20V (42V)	2 channel	≈25W	550mΩ (HS) 450mΩ (LS)	<ul style="list-style-type: none"> ■ LIN 2.x (1.3 comp.) or SAE-J2602 ■ LIN Flash update ■ JTAG 	QFN32L6	<ul style="list-style-type: none"> ■ Current chopper motor control ■ Supply and read-out of up to 3 sensors ■ Embedded 8bit μC ■ 8k Flash ■ T_{Junc} peak = +170°C
E523.39 *Plug & Play SPI Stepper Driver	5.5V to 28V (42V)	2 channel	40W	0.5Ω (HS) 0.5Ω (LS)	<ul style="list-style-type: none"> ■ SPI-compatible (3.3/5V) 	QFN20L5 QFN32L6	<ul style="list-style-type: none"> ■ Stall-Detection / analysis / position correction ■ Sensitive Fail-Current-Detection ■ Over modulation with customized waveforms ■ Supporting Adaptive-Holding-Torque ■ Supporting Adaptive-Run-Current ■ T_{Junc} peak = +170°C
E520.01/02 *Driver IC 12x Low-Side for 3 Stepper Motors with/without Stall Detection	3V to 25V (42V)	12 channel	≈12x 8.75W	1.5Ω	<ul style="list-style-type: none"> ■ SPI-compatible (3.3/5V) 	QFN32L5 SOIC28	<ul style="list-style-type: none"> ■ Stall detection for stepper motors (E520.01) suitable for Full Step, Half Step, Wave Drive ■ 245Hz LED mode ■ 25kHz relay mode ■ 25kHz linear PWM ■ T_{Junc} peak = +150°C
E520.03/08 *Driver IC 8x Low-Side for 2 Stepper Motors with/without Stall Detection	3V to 25V (42V)	8 channel	≈8x 8.75W	1.5Ω	<ul style="list-style-type: none"> ■ SPI-compatible (3.3/5V) 	SOIC20 QFN20L5 QFN32L5	<ul style="list-style-type: none"> ■ Stall detection for stepper motors (E520.03) suitable for Full Step, Half Step, Wave Drive ■ 245Hz LED mode ■ 25kHz relay mode ■ 25kHz linear PWM ■ T_{Junc} peak = +150°C

Power Stepper Controller with Stall Detection | E523.30/31

Key Features

- Drives a bipolar stepper motor
- Sensorless “stall detection”
- I - Coil current up to 2 x 800mA (prog. chopper)
- 5.5V - 20V supply voltage (load dump 42V)
- Sleep mode current typically 30µA
- Embedded 8bit µC 256 Byte RAM, 8k Flash, 64 Byte E²PROM
- Versions: LIN/PWM Interface, optional LIN Auto-Addressing

Board

- Order No. see page 46



Applications

- Stepper or DC motor actuators
- Grill-Shutter
- Head-Light adjust
- Water valve

Packages

- QFN32L6

Application Diagram

*SoC / *Plug & Play

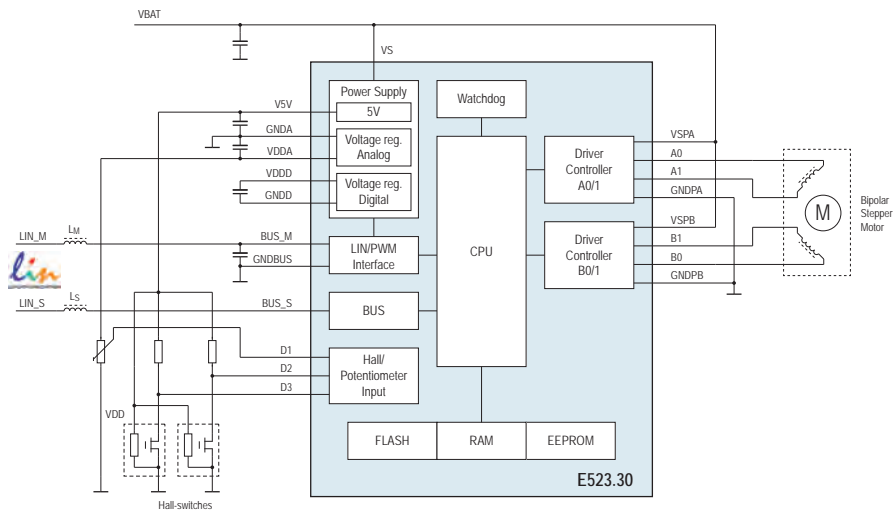

SPI Stepper Driver | E523.39

Key Features

- 5V..28V motor run; VBAT,max 40V (42V for 500ms)
- “Stop/Start” & “cold crank” compliant
- Stall-Detection
- Fail-Current-Detection
- Adaptive-Holding and Running-Torque supported
- Custom Current Waveform: increase of speed and peak power at high temperatures or low VBAT
- AEC-Q 100 Grade 0

Board

- Order No. see page 46



Applications

- Automotive, High-Temperature, Industrial
- 4-phase positioning actuators, fans, pumps

Packages

- QFN20L5
- QFN32L6

Application Diagram

*SoC / *Plug & Play

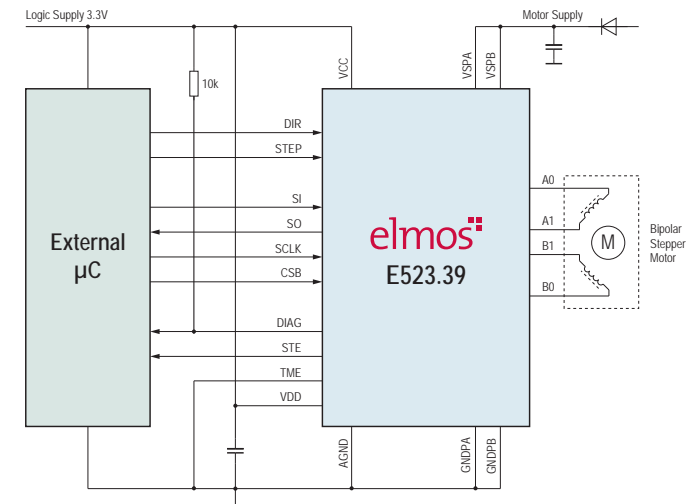

12/8x Low-Side Driver with Stall Detection | E520.01/02/03/08

Key Features

- 12 high current outputs ($R_{DS(on)}$ typ. 1.5Ω / $I_{MAX} = 350mA$)
- Low standby current (typically $<1\mu A$)
- Serial interface (SPI) for direct μC interfacing
- Short circuit / Open load detection, diagnosis
- Stall detection for full-/half-step, wave drive
- Stall detection qualification service
- T_{junc} peak = $+150^{\circ}C$

Board

- Order No. see page 46



Applications

- Stepper motor driver with/without stall detection
- DC motor driver with PWM
- Relay driver with VBAT- automatically PWM
- LED driver with 3 logarithmic PWM sources

Packages

- E520.01/02
QFN32L5, SOIC28
- E520.03/08
QFN32L5, QFN20L5, SOIC20

Application Diagram

*Driver IC

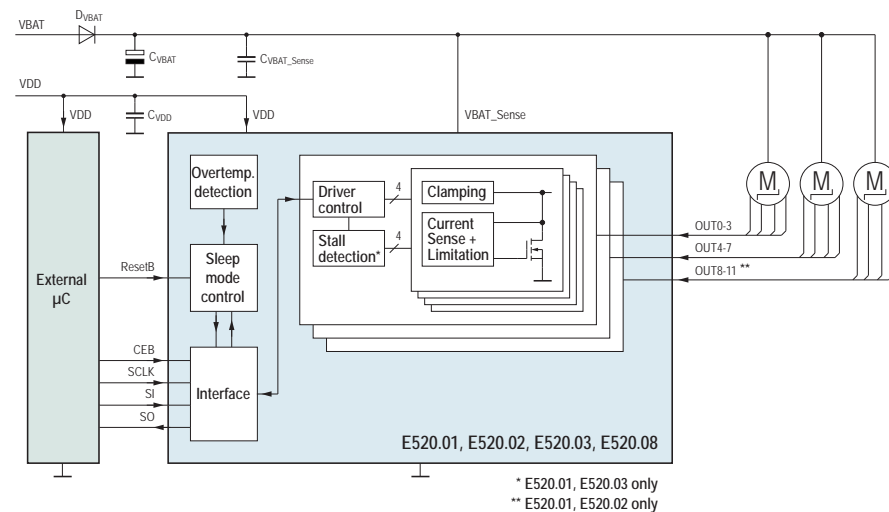



Head Light Adjustment

Motor Control - BLDC Motor | Switched Reluctance Motor**

BLDC Motor Controller

Part No. / Function	V _{SUPPLY}	I _{PEAK}	P(Motor)peak	RDS _{ON}	Interface	Package	Comment
E523.06 *SoC Field-Oriented BLDC Motor Controller with 16 Bit CPU *Plug & Play Demosoftware for - sensorless HVAC fan - engine cooling fan - field oriented control (FOC) for pumps	7V to 28V (5V to 42V)	6 channel	≈1.5kW (external FETs) ≈3W (direct drive)	8Ω (HS) 4Ω (LS)	<ul style="list-style-type: none"> ■ LIN 2.x (1.3 comp.), SAE-J2602 or PWM bidirectional ■ SPI for user expansion ■ LIN Flash update ■ JTAG 	QFN48L7 LQFP48L7EP	<ul style="list-style-type: none"> ■ 16bit/48 MHz CPU assisted by 2 powerful co-processors ■ Library ROM for LIN-stack software update via LIN ■ Software support on request ■ T_{Junc} peak = +150°C
E523.05 *SoC BLDC Motor Controller with 16bit CPU (LIN/PWM Interface)	7V to 28V (5V to 42V)	6 channel	≈1.5kW (external FETs) ≈3W (direct drive)	8Ω (HS) 4Ω (LS)	<ul style="list-style-type: none"> ■ LIN 2.x (1.3 comp.), SAE-J2602 or PWM bidirectional ■ SPI for user expansion ■ LIN Flash update ■ JTAG 	QFN48L7	<ul style="list-style-type: none"> ■ For new designs E523.06 is recommended ■ 16bit/48 MHz CPU assisted by 2 powerful co-processors ■ Library ROM for LIN-stack software update via LIN ■ Software support on request ■ T_{Junc} peak = +125°C (contact supplier for higher temperature)
E523.52 *SoC 72V Brushless Motor Gate Driver with 16bit CPU *Plug & Play Demosoftware on request	12V to 72V (7V to 76V)	6 channel	≈1.5kW (external FETs)	10Ω (HS) 5Ω (LS)	<ul style="list-style-type: none"> ■ LIN Interface with external ■ PWM Interface with external components ■ SPI for user expansion ■ LIN transceiver ■ LIN Flash update ■ JTAG 	QFN36L7	<ul style="list-style-type: none"> ■ Usable for 24/48V automotive Board Net ■ 16bit/48 MHz CPU assisted by 2 powerful co-processors ■ Library ROM for LIN-stack software update via LIN (software support on request) ■ T_{Junc} peak = +150°C

***Plug & Play** Chip with defined functionality | no controller programming necessary
***SoC** System-on-a-Chip | with integrated microcontroller
***SBC** System-Basic-Chip | with Voltage Regulator Reset, Watchdog, physical Interface
***Driver IC** Driver Chip without SBC or SoC features

** Please contact Elmos for selecting the right product for SR Motors

BLDC Motor Driver

Part No. / Function	V _{SUPPLY}	I _{PEAK}	P(Motor)peak	RDS _{ON}	Interface	Package	Comment
E523.42 Fully Integrated 3 Phase Motor Controller	*SoC 7V to 28V (6V to 42V)	6 channel	≈14W	6Ω (HS) 6Ω (LS)	<ul style="list-style-type: none"> LIN 2.x (1.3 comp.), SAE-J2602 or PWM bidirectional LIN Flash Update JTAG 	QFN32L5	<ul style="list-style-type: none"> 32bit / 24MHz ARM® Cortex®-M0 Library ROM for LIN-stack software update via LIN T_{Junc} peak = +150°C Software support on request
E523.81 500mA BLDC Motor Controller	*Plug & Play 6V to 28V (5V to 42V)	1 channel	7kW	10Ω (HS) 5Ω (LS)	<ul style="list-style-type: none"> PWM bidirectional analog 0 - 2.5V JTAG 	QFN20L5	<ul style="list-style-type: none"> State Machine control Fully parametrisable via JTAG True Sinusoidal SVM (Space Vector Modulation) Drive T_{Junc} peak = +170°C
E523.01/11 BLDC Motor Driver (LIN/PWM Interface)	*SBC 7V to 28V (5V to 42V)	6 channel	≈1.5kW (external FETs) ≈3W (direct drive)	8Ω (HS) 4Ω (LS)	<ul style="list-style-type: none"> LIN 2.x (1.3 comp.), SAE-J2602 (only E523.01) or PWM bidirectional LIN Flash update 	QFN44L7 QSOP44	<ul style="list-style-type: none"> Voltage Regulator (3.3V/5V) selectable Precise deadtime generation Watchdog/Diagnostics T_{Junc} peak = +170°C Demo software on request (sensorless sinus)
E523.10 BLDC-Motor Driver with Cold-Crank Capability	*SBC 7V to 28V (4.5V to 42V)	6 channel	≈1.5kW (external FETs) ≈3W (direct drive)	8Ω (HS) 4Ω (LS)	<ul style="list-style-type: none"> PWM bidirectional SPI for configuration 	QFN44L7	<ul style="list-style-type: none"> Voltage Regulator (3.3V/5V) selectable Precise deadtime generation Watchdog/Diagnostics T_{Junc} peak = +170°C
E523.50 72V Brushless Motor Gate Driver	*SBC 12V to 72V (7V to 76V)	6 channel	≈1.5kW (external FETs)	10Ω (HS) 5Ω (LS)	<ul style="list-style-type: none"> PWM for motor control Diagnostic PINs 	QFN36L7	<ul style="list-style-type: none"> Usable for 24/48V automotive Board Net DC/DC converter for gate supply 3.3V/20mA supply for external μC T_{Junc} peak = +150°C

***Plug & Play** Chip with defined functionality | no controller programming necessary
***SoC** System-on-a-Chip | with integrated microcontroller
***SBC** System-Basic-Chip | with Voltage Regulator Reset, Watchdog, physical Interface
***Driver IC** Driver Chip without SBC or SoC features

****** Please contact Elmos for selecting the right product for SR Motors

Field-Oriented BLDC Motor Controller with 16 Bit CPU | E523.06

Key Features

- IC supply voltage range 7 to 28V (extended 5V to 42V)
- CPU 16 bit, 24 - 48MHz for application tasks
- 32 kByte Flash, ECC protected
- 24 kByte Masked ROM
- 4 kByte SRAM, parity protected
- Typical deep-sleep mode current 20µA
- 2nd window watchdog and two independent clocks
- LIN 2.x (1.3, SAE-J2602 comp.) or PWM bidirectional
- Fast OpAmp for foot current measurement

Board

- Order No. see page 46



Applications

- BLDC(EC) motor control, multiple DC motor control
- Cooling fans, HVAC fans, positioning systems
- Fuel, hydraulic, oil and water pumps
- Position system

Packages

- QFN48L7
- LQFP48L7EP

Application Diagram

*SoC / *Plug & Play

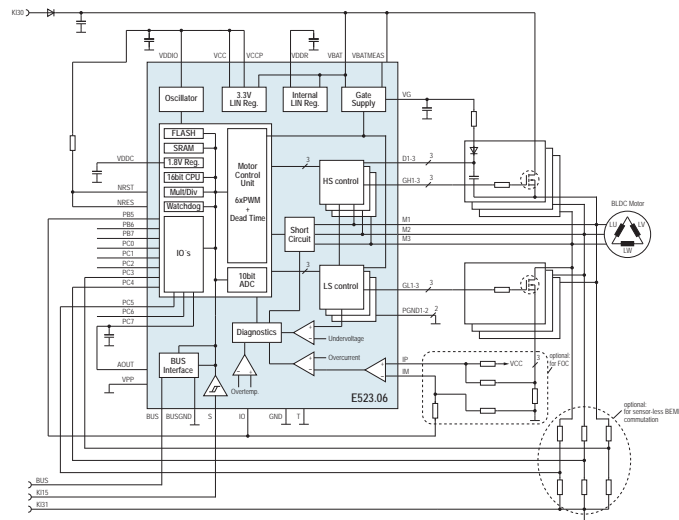

72V Brushless Motor Gate Driver with 16bit CPU | E523.52

Key Features

- Voltage range 12V to 72V (7V to 76V peak)
- CPU 16 bit, 24 - 48MHz for application tasks
- 32kByte Flash, 16kByte MaskROM, 4kByte SRAM
- 10 bit 1 Msample SAR ADC
- 4x 16 bit PWM generation (edge/center aligned)
- Adjustable window watchdog (independent clock)
- 6x 200mA gate drivers with programmable dead time and protection features
- Fast OpAmp for foot current measurement

Board

- Order No. see page 47



Applications

- BLDC(EC) motors in industrial 24V to 60V applications
- Commercial vehicles
- Fuel, hydraulic, oil, water and urea pumps
- Cooling fans, HVAC fans, positioning systems

Packages

- QFN36L7

Application Diagram

*SoC / *Plug & Play

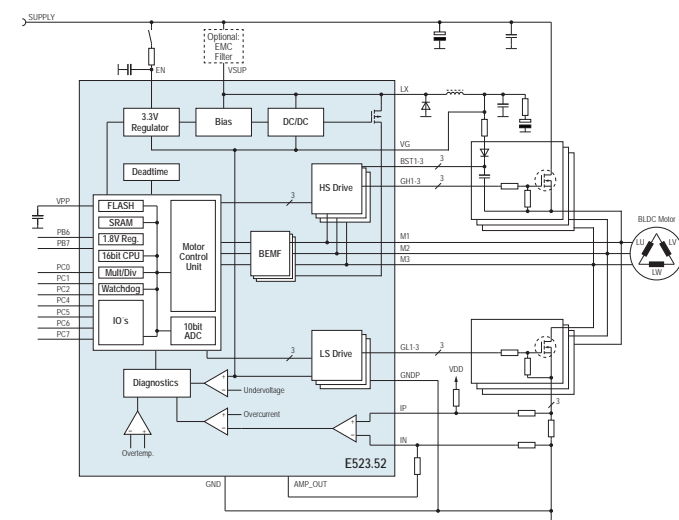

BLDC-Motor Driver with Cold-Crank Capability | E523.10

Key Features

- Gate drive circuit for B6-NMOS bridge
- Voltage range 4.5V to 28V (42V peak) for start-stop systems
- Sleep mode current 20µA typically
- Microcontroller supply 3.3V or 5V
- Adjustable watchdog and reset generation
- Motor current measurement amplifier
- Over current switch-off (dynamical change)
- FET short circuit protections (dynamical change)
- Configurable voltage monitoring

Board

- Order No. see page 47



Applications

- BLDC (EC) motor control, multiple DC motor control
- Fuel, hydraulic, oil and water pumps
- Cooling fans, HVAC fans, positioning systems
- Turbo charger adjustment

Packages

- QFN44L7

Application Diagram

*SoC / *Plug & Play

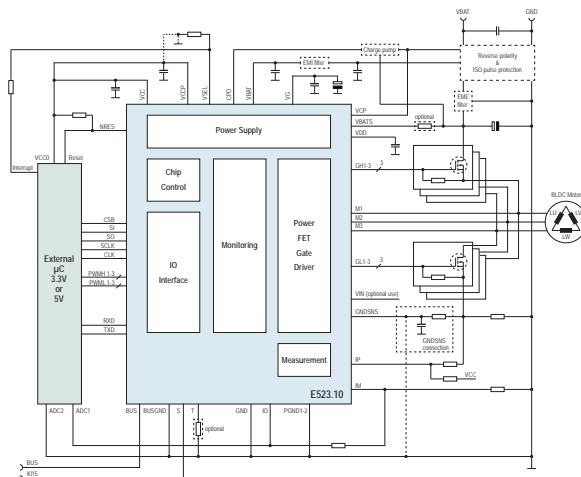

72V Brushless Motor Gate Driver | E523.50

Key Features

- Gate drive circuit for B6-NMOS bridge
- Voltage range 12V to 72V (7V to 76V peak)
- DC/DC converter for 11V/100mA
- µC supply 3.3V up to 20mA direct load, higher loads with external boost transistor possible
- 200mA gate drivers including protection features
- Integrated back EMF detection
- T_{Junc} peak = +150°C

Board

- Order No. see page 47



Applications

- BLDC (EC) motors in industrial 24V to 60V applications
- Commercial vehicles
- Fuel, hydraulic, oil, water and urea pumps
- Cooling fans, HVAC fans, positioning systems

Packages

- QFN36L7

Application Diagram

*SBC

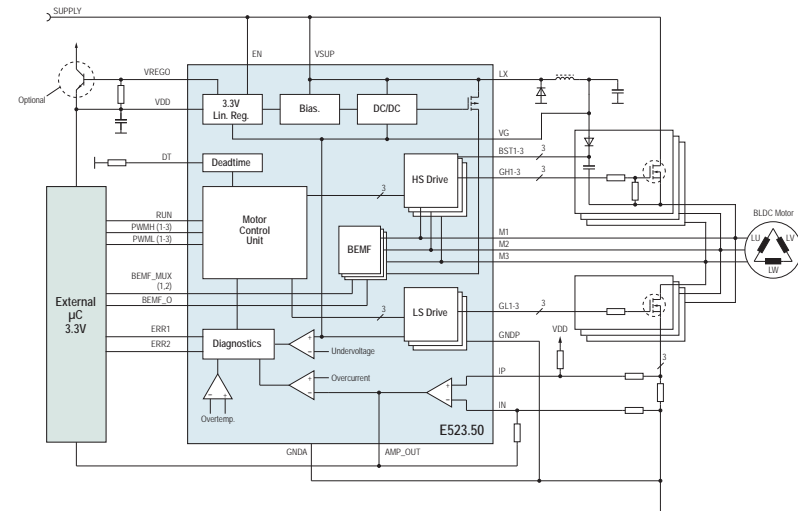

500mA BLDC Motor Controller | E523.81

Key Features

- IC for standalone PMSM applications
- Internal power bridge up to 500mA (rms)
- Selectable PWM speed and error interface or analog speed interface
- Tacho output
- Current controlled start up
- Integrated configurable error handling
- Stall detection
- Automatic restart and rotor delocking

Board

- Order No. see page 47



Applications

- Small PMSM / BLDC FANs
- Small PMSM / BLDC Pumps

Packages

- QFN20L5

Application Diagram

*Plug and Play

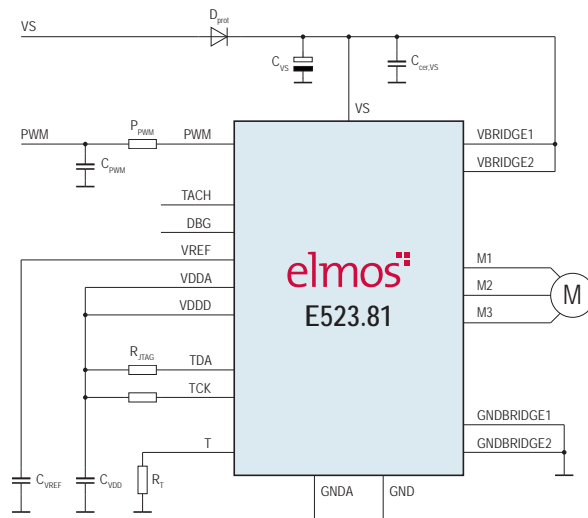

Motor Control - DC Motor

Part No. / Function	V _{SUPPLY}	I _{PEAK}	P(Motor)max	RDS _{ON}	Interface	Package	Comment
E523.26 *SoC DC Motor Driver with 16kB Flash	5V to 20V (5V to 40V)	1 channel	≈1.5kW (external FETs) ≈1.3W (direct drive)	8Ω (HS) 8Ω (LS)	<ul style="list-style-type: none"> ■ LIN 2.x (1.3) or SAE-J2602 ■ SPI for configuration 	QFN32L6	<ul style="list-style-type: none"> ■ Includes μC, memory, interfaces, high side gate driver, supply and measurement functions ■ T_{Junc} peak = +150°C
E523.03/04/13/14 *SBC DC Motor LS FET Driver (LIN / PWM Interface)	7V to 28V (5V to 42V)	1 channel	≈1.5kW (external FETs) ≈1.3W (direct drive)	8Ω (HS) 4Ω (LS)	<ul style="list-style-type: none"> ■ LIN 2.x (1.3) or SAE-J2602 (only E523.03/13) or PWM bidirectional ■ SPI for configuration 	QFN20L4 QFN32L5 (with high voltage spacer)	<ul style="list-style-type: none"> ■ Voltage Regulator E523.03/13: 5V E523.04/14: 3.3V ■ Watchdog/Diagnostics ■ Fast LIN Flash update ■ T_{Junc} peak = +170°C
E910.72 *Driver IC 6x Half-Bridge DC Motor with sensorless positioning	6V to 19V (40V)	-	≈7W (1 Motor Mode)	1.25Ω	<ul style="list-style-type: none"> ■ SPI for configuration 	QFN32L5	<ul style="list-style-type: none"> ■ Sensorless motor positioning ■ 3 independent pulse detectors ■ Excellent positioning performance ■ Drives 3 or 5 DC actuators ■ T_{Junc} peak = +150°C

- *Plug & Play Chip with defined functionality | no controller programming necessary
- *SoC System-on-a-Chip | with integrated microcontroller
- *SBC System-Basic-Chip | with Voltage Regulator Reset, Watchdog, physical Interface
- *Driver IC Driver Chip without SBC or SoC features

Part No. / Function	V _{SUPPLY}	I _{PEAK}	P(Motor)max	RDS _{ON}	Interface	Package	Comment
E523.30 *SoC 2x Full Bridge Controller (LIN / PWM Interface) *Plug & Play Demosoftware on request	7V to 20V (5.5V to 42V)	2 channel	≈25W (per Motor)	225mΩ (HS) 275mΩ (LS)	<ul style="list-style-type: none"> LIN 2.x (1.3) or SAE-J2602 or PWM bidirectional LIN auto-addressing (slave mode position detection) LIN Flash update for EoL and Service JTAG 	QFN32L6	<ul style="list-style-type: none"> Drives 1 or 2 DC motors 8bit CPU, 8k Flash, 64Byte E²PROM Current chopper motor control Supply and read-out of up to 3, potentiometers or sensors GPIO-pins T_{Junc} peak = +170°C (contact supplier for higher temperatures)
E523.39 *Driver IC 2x Full Bridge Driver (SPI Interface)	5.5V to 20V (42V)	2 channel	40W	0.5Ω (HS) 0.5Ω (LS)	<ul style="list-style-type: none"> SPI for configuration 	QFN20L5 QFN32L6	<ul style="list-style-type: none"> Stall-Detection / analysis / position correction Sensitive Fail-Current-Detection Over modulation with customized waveforms Supporting Adaptive-Holding-Torque Supporting Adaptive-Run-Current T_{Junc} peak = +170°C
E523.06 *SoC Field-Oriented DC Motor Controller with 16 Bit CPU	7V to 28V (5V to 42V)	6 channel	≈1.5kW (external FETs) ≈1.3W (direct drive)	8Ω (HS) 4Ω (LS)	<ul style="list-style-type: none"> LIN 2.x (1.3) or SAE-J2602 or PWM bidirectional SPI for configuration LIN Flash update JTAG 	QFN48L7 LQFP48L7EP	<ul style="list-style-type: none"> 16bit/48 MHz CPU assisted by 2 powerful co-processors Library ROM for LIN-stack software update via LIN Charge Pump Driver included T_{Junc} peak = +125°C (Contact supplier for higher temperature)

- *Plug & Play Chip with defined functionality | no controller programming necessary
 *SoC System-on-a-Chip | with integrated microcontroller
 *SBC System-Basic-Chip | with Voltage Regulator Reset, Watchdog, physical Interface
 *Driver IC Driver Chip without SBC or SoC features

DC Motor Driver with 16kB Flash | E523.26

Key Features

- Includes μC , memory, interfaces, high side gate driver, supply and measurement functions
- 8bit processor core, EL3.5, 512 Bytes RAM
- 16k Flash memory
- 16 words EEPROM Customer Data
- On-Chip ADC for measurement of motor current, supply voltage, temperature and up to three other analog voltages
- Gate driver for NMOS high side FET
- AEC-Q100 Qualified

Board

- Order No. see page 46



Applications

- Control of brush DC motors of fans/blowers in automotive applications

Packages

- QFN32L6

Application Diagram

*SBC

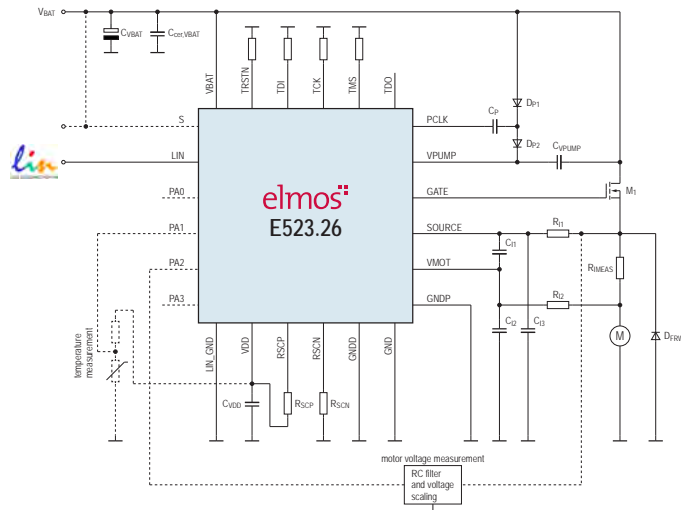

DC Motor LS FET Driver (LIN / PWM Interface) | E523.03/04/13/14

Key Features

- Voltage range 7 to 28V (5V to 42V peak)
- LIN 2.x (1.3, SAE-J2602 comp.) or PWM bidirectional
- Deep sleep mode current $I < 30\mu\text{A}$
- Voltage Regulator for ext. μC : 3.3V/5V, $I_{\text{MAX}} = 30\text{mA}$
- Window-watchdog, dynamical change via SPI
- Amplifier for low side motor current measurement
- Over-current switch-off, dynamical change via SPI
- Monitoring battery voltage, gate supply, temperature

Board

- Order No. see page 46



Applications

- DC Wiper
- DC HVAC fan, engine cooling fan
- DC fuel pump, hydraulic pump, oil pump
- Multiple DC motor control
- Without external FETs: direct driving of small loads

Packages

- QFN20L4
- QFN32L5 (with high voltage spacer)

Application Diagram

*SBC

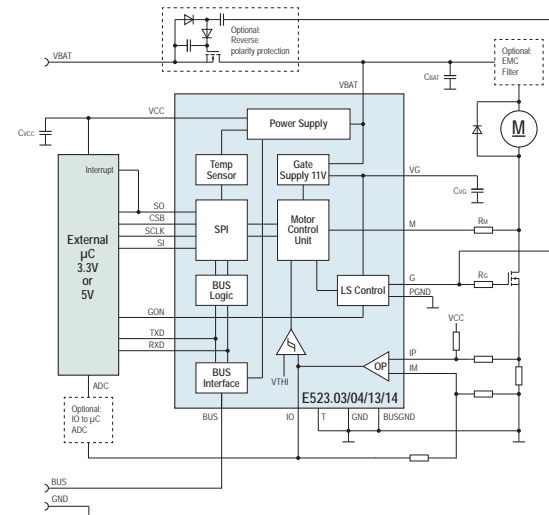

Field-Oriented DC Motor Controller with 16 Bit CPU | E523.06

Key Features

- Gate drive circuit for B6-NMOS bridge
- IC supply voltage range 7 to 28V (extended 5V to 42V)
- CPU 16 bit, 24 - 48MHz for application tasks
- 32 kByte Flash, ECC protected
- 24 kByte Masked ROM
- 4 kByte SRAM, parity protected
- Typical deep-sleep mode current 20µA
- 2nd window watchdog and two independent clocks
- LIN2.x, LIN1.3 or bidirectional PWM Interface

Board

- Order No. see page 46



Applications

- EC, BLDC, PMSM motors 50W to ~1500W
- Cooling fans, HVAC fans, positioning systems
- Fuel, hydraulic, oil and water pumps

Packages

- QFN48L7
- LQFP48L7EP

Application Diagram

*SoC / *Plug & Play

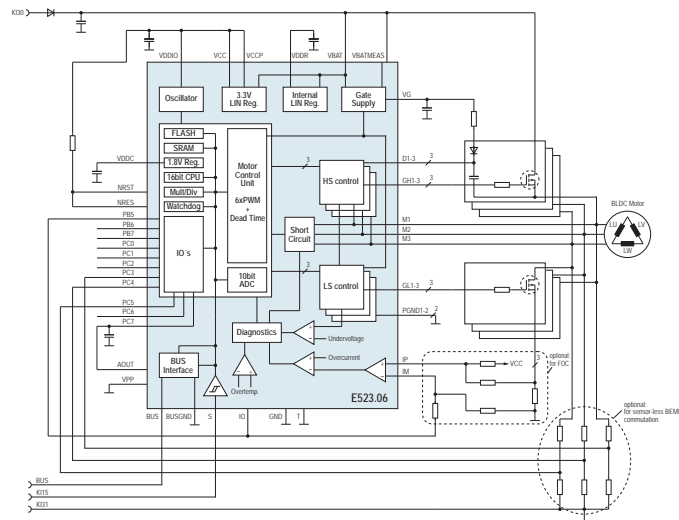

2x 800mA DC Motor 2x Full Bridge Controller (LIN / PWM Interface) | E523.30

Key Features

- Voltage range 7V to 20V (5.5V to 42V)
- LIN 2.x (1.3, SAE-J2602 comp.) or PWM bidirectional
- Drives 1 or 2 DC Motors
- 800mA (2 Motor Mode)
- Programmable chopper current
- Slave node position detection / auto-addressing
- 8bit CPU, 8k Flash, 64Byte E²PROM
- 3 GPIO pins and sensor supply

Board

- Order No. see page 46



Applications

- Headlight adjust
- Grille shutter
- Water valves
- Multi purpose LIN slave

Packages

QFN32L6

Application Diagram

*SoC / *Plug & Play

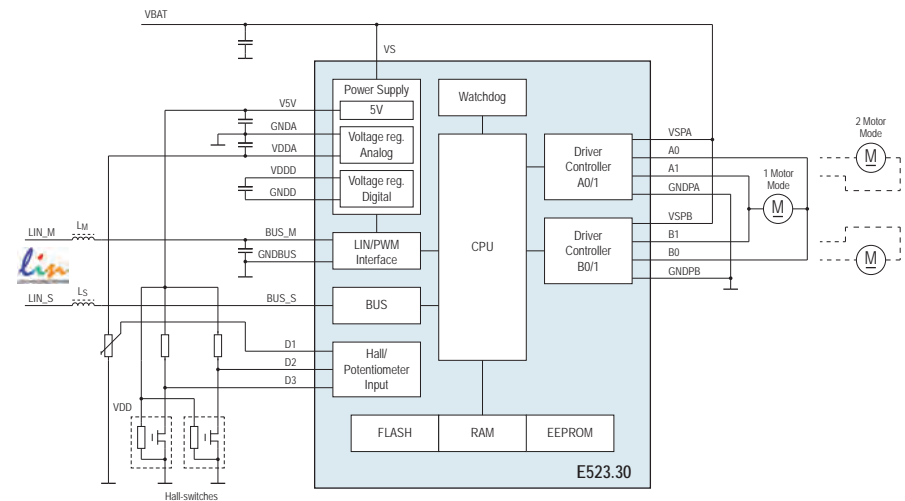

2x Full Bridge Driver (SPI Interface) | E523.39

Key Features

- 5V .. 28V motor run; VBAT,max 40V (42V for 500ms)
- "Stop/Start" & "cold crank" compliant
- Stall-Detection
- Fail-Current-Detection
- Adaptive-Holding and Running-Torque supported
- Custom Current Waveform: increase of speed and peak power at high temperatures or low VBAT
- AEC-Q 100 Grade 0

Board

- Order No. see page 46



Applications

- Automotive, High-Temperature, Industrial
- 4-phase positioning actuators, fans, pumps

Packages

- QFN20L5
- QFN32L6

Application Diagram

*SoC / *Plug & Play

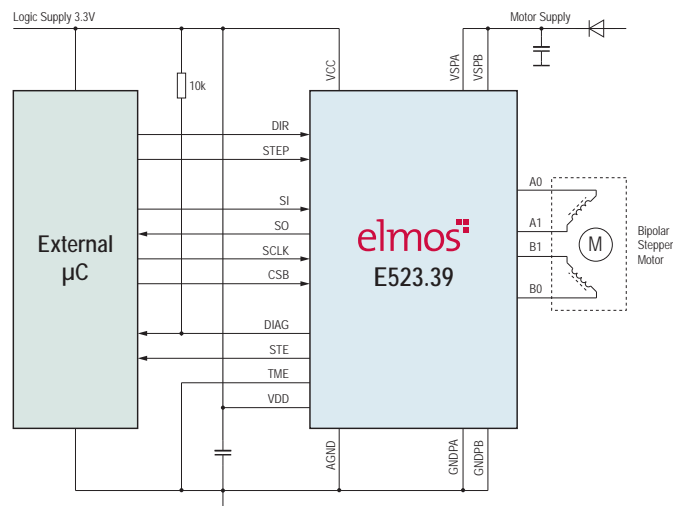

6x Half-Bridge DC Motor with Sensorless Positioning | E910.72

Key Features

- Operating supply voltage range 6V to 19V
- 6 half bridges to drive 3, 4, or 5 DC motors
- $R_{DS,ON}$ of one half bridge typ. 1.25Ω
- Independent pulse detectors for three motors
- 2 different pulse detectors covering the complete speed range
- Adjustable parameters to drive a high number of different motor types
- Diagnostic data via SPI

Board

- Order No. see page 46



Applications

- Automotive HVAC flap
- DC motor servo systems

Packages

- QFN32L5

Application Diagram

*Driver IC

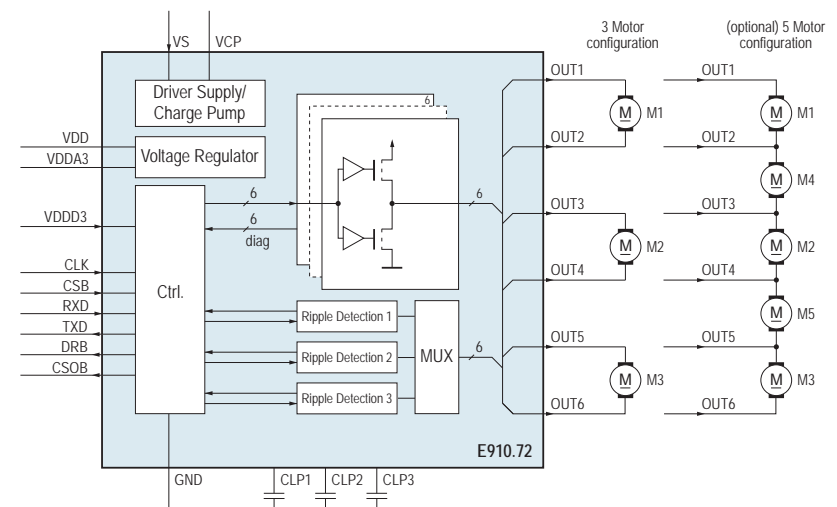



Engine Cooling Fan Control

Motor Control - Boards

Stepper Motor

Part No.	Demo also relative for	Function	Board type	Order No.
E520.01	E520.02, E520.03, E520.08	12x Low-Side for 3 Stepper Motors with/without Stall Detection	Demo- / Evaluation Board	K52001-0001
E523.30*	E523.31, E523.34, E523.37	LIN Stepper Evakit (Standard)	Demo- / Evaluation Board	K52330-0001
E523.30*	E523.31, E523.34, E523.37	LIN Stepper Evakit (Generic)	Demo- / Evaluation Board	K52330-0002
E523.30*	E523.31, E523.34, E523.37	LIN Stepper SW Evakit (Standard)	Demo- / Evaluation Board	K52330-0003
E523.30*	E523.31, E523.34, E523.37	LIN Stepper SW Evakit (Generic)	Demo- / Evaluation Board	K52330-0004
E523.39*	-	-	Evaluation Board	K52339-0001
E523.39*	-	-	Smart-GUI Kit	K52339-0002

* also valid for DC Motor boards

DC Motor

Part No.	Demo also relative for	Function	Board type	Order No.
E523.03	E523.04, E523.13, E523.14	DC Motor LS FET Driver (LIN / PWM Interface)	Demo- / Evaluation Board	K52303-0001
E523.06	-	Field-Oriented DC Motor Controller with 16 Bit CPUv (Standard)	Demoboard	K52306-0001
E523.06	-	Field-Oriented DC Motor Controller with 16 Bit CPU 50W	Demoboard	K52306-0003
E523.06	-	Field-Oriented DC Motor Controller with 16 Bit CPU 300W FOC	Demoboard	K52306-0004
E523.06	-	Field-Oriented DC Motor Controller with 16 Bit CPU 300W CZCD (Current Zero Cross Detection)	Demoboard	K52306-0005
E523.06	-	Field-Oriented DC Motor Controller with 16 Bit CPU 1kW FOC	Demoboard	K52306-0006
E523.26	-	DC Motor Driver with 16kB Flash with LIN	Demoboard	K52326-0001
E910.72	-	6x Half-Bridge DC Motor with Sensorless Positioning	Demo- / Evaluation Board	K91072-0001

BLDC Motor

Part No.	Function	Board type	Order No.
E523.01/11	B6 Bridge FET Driver (LIN / PWM Interface)	Demo- / Evaluation Board	K52301-0001
E523.01/11 V1 Fan	B6 Bridge FET Driver (LIN / PWM Interface)	Demo- / Evaluation Board	K52301-0002
E523.01/11 V2 Pump	B6 Bridge FET Driver (LIN / PWM Interface)	Demo- / Evaluation Board	K52301-0003
E523.01/11 V4 Water Pump	B6 Bridge FET Driver (LIN / PWM Interface)	Demo- / Evaluation Board	K52301-0005
E523.10	BLDC Motor Driver with Cold Crank Capability	Demoboard	K52310-0001
E523.42	3-Phase Motor Controller	Evaluation Board	K52342-0001
E523.42	3-Phase Motor Controller	Socket Board	K52342-0002
E523.50	72V Brushless Motor Gate Driver	Demo- / Evaluation Board	K52350-0001
E523.52	72V Brushless Motor Gate Driver with 16bit	Demo- / Evaluation Board	K52352-0001
E523.52	72V Brushless Motor Gate Driver with 16bit (High Power)	Evaluation Board	K52352-0002
E523.81	500mA BLDC Motor Controller	Demoboard	K52381-0001

Power Management - LED Drivers

Part No. / Description	Efficiency	V _{SUPPLY}	I _{OUT}	Package	Comment / Converter Topology
E521.31 LIN Controller with Position Detection	-	5V to 28V (max. 40V)	4 x 50mA	QFN32L5	<ul style="list-style-type: none"> Linear Controller 1st Gen RGB LED driver (incl.: Flash, 4xPWM, 5V/100mA LDO)
E521.36 RGB LIN Controller with Current Source	-	5V to 28V (max. 40V)	3 x 40mA	SOIC8-EP	<ul style="list-style-type: none"> Linear Controller 2nd Gen RGB LED driver (incl.: OTP, 4xPWM, 5V/100mA LDO)
E522.80-83 Triple Linear LED Controller (High Current Version 48 to 151mA)	-	5V to 25V	3 x 150 or 450mA	SOIC16N-EP	<ul style="list-style-type: none"> Linear Controller Power Zeroing Function
E522.84-87 Triple Linear LED Controller (Low Current Version 20 to 60mA)	-	5V to 25V	3 x 60 or 180mA	SOIC8-EP	<ul style="list-style-type: none"> Linear Controller
E522.90-93 Triple 55mA Linear LED Controller (14 to 55mA)	-	5V to 25V	3 x 55 or 165mA	SOIC16N-EP	<ul style="list-style-type: none"> Linear Controller Power Zeroing Function
E522.46 8 Channel LED Driver with I ² C Interface	-	3.3V to 32V (max. 40V)	212 mA	DFN18L5040	<ul style="list-style-type: none"> Linear Controller
E522.48 16 Channel LED Driver with I ² C Interface	-	5V to 40V	-	QFN32L6	<ul style="list-style-type: none"> Linear Controller ISO26262 - ASIL-B, Power Zeroing Function
E522.49 16 Channel LED Driver with Diff. Bus Interface	-	5V to 40V	-	QFN32L6	<ul style="list-style-type: none"> ISO26262 - ASIL-B, Power Zeroing Function
E522.31/33 1 Channel Switched-Mode Constant Current LED Controller (Oscillator Spectrum Spread/Narrow)	>90%	5V to 55V	-	QFN32L5	<ul style="list-style-type: none"> Boost, SEPIC, Buck-Boost or Buck
E522.32/34 2 Channel Switched-Mode Constant Current LED Controller (Oscillator Spectrum Spread/Narrow)	>90%	5V to 55V	-	QFN32L5	<ul style="list-style-type: none"> Boost, SEPIC, Buck-Boost or Buck
E521.71 DRL & Position Light Driver IC for 2 Wheeled Vehicles	-	5V to 24V (max. 40V)	3 x 150 or 450mA	SOIC16N-EP	<ul style="list-style-type: none"> Linear Controller Power Zeroing Function Not automotive qualified

LIN Controller with Position Detection | E521.31

Key Features

- Transceiver compliant with LIN 2.1, LIN 2.2 and SAE-J2602
- Linear voltage regulator with 5V, 100mA
- State of the art 16bit μ C
- Integrated 32kbyte Flash (Flexible EEPROM emulation by SW)
- 4x PWM driven High Side drivers with 5V and up to 50mA each
- μ C window watchdog
- ADC 12bit accuracy

Board

- Order No. see page 60



Applications

- Interior light modules

Packages

- QFN32L5

Application Diagram

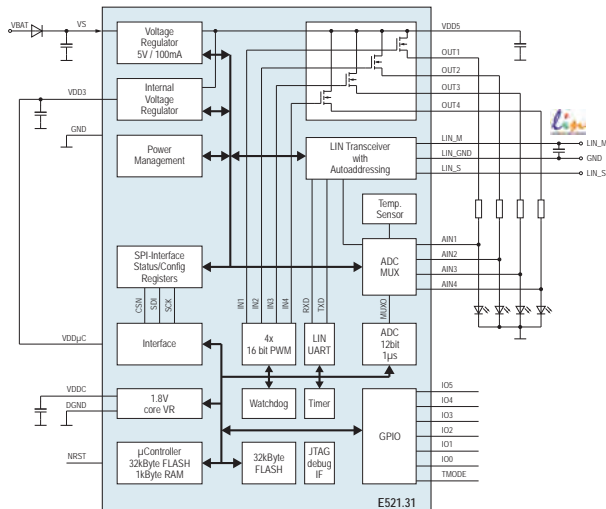

RGB LIN Controller with Current Source | E521.36

Key Features

- Input voltage range 5V to 28V
- Integrated 16 bit microcontroller
- 32kByte OTP
- 128Byte customer usable non-volatile memory
- 1.25kByte RAM 16kByte SysROM containing standard LIN routines and boot loader
- 4 PWM generators with 48MHz and 16bit resolution
- 2 Timers with 16bit resolution
- 3 LED drivers with currents up to 40mA and fast slopes

Board

- Order No. see page 60



Applications

- Interior light modules
- Ambient lighting

Packages

- SOIC8-EP

Application Diagram

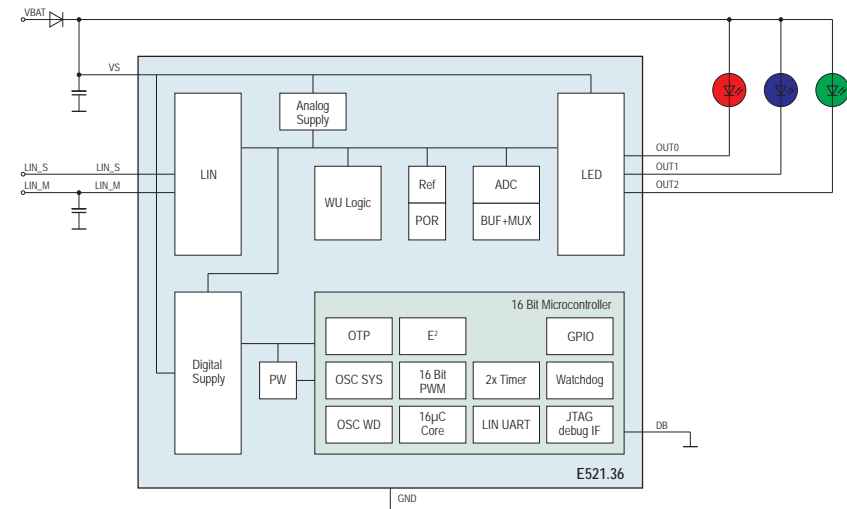

Linear LED Controller (High Current Version 48 to 151mA) | E522.80-83

Key Features

- Three independent linear current drivers (3*150mA)
- Operating input voltage range 5V to 25V, max. 40V
- Advanced diagnostic features
 - Open / short detection
 - Diagnostic "RUN" bus to link multiple ICs
- Different start-up voltages for open diagnostics can be chosen: VS=7.5V, 9V, 10V and 15V
- "Single Lamp" mode disables all LEDs in case of a failure
- Automotive qualified (AEC-Q100)

Board

- Order No. see page 61



Applications

- Automotive LED lighting
- Rear lighting
- Turn indicator driver
- Low current interior lighting
- Industrial LED applications or simple RGB drivers

Packages

- SOIC16N-EP

Application Diagram

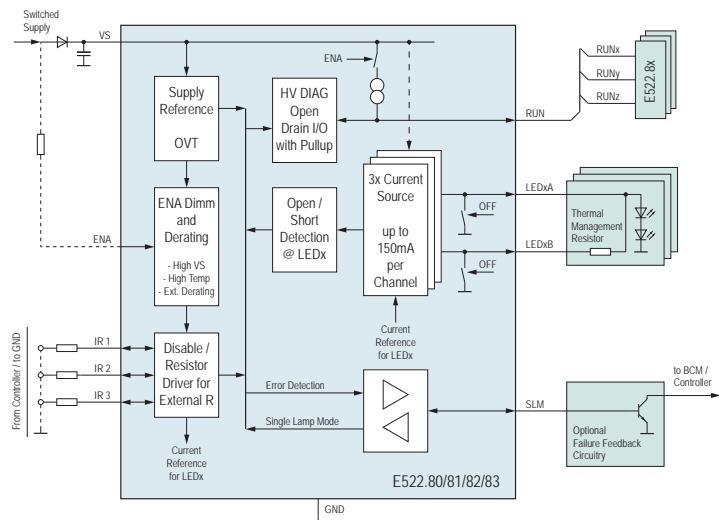

Linear LED Controller (Low Current Version 20 to 60mA) | E522.84-87

Key Features

- Three integrated linear current drivers (3*60mA)
- Operating input voltage range 5V to 25V, max. 40V
- Advanced diagnostic features
 - Open / short detection
 - Diagnostic "RUN" bus to link multiple ICs
- Different start-up voltages for open diagnostics can be chosen: VS=7.5V, 9V, 10V and 15V
- "Single Lamp" mode disables all LEDs in case of a failure
- Automotive qualified (AEC-Q100)

Board

- Order No. see page 61



Applications

- Automotive LED Lighting, Rear Lighting
- Turn Indicator Driver
- Low Current Interior Lighting
- Industrial LED Applications or simple RGB Drivers

Packages

- SOIC8EP

Application Diagram

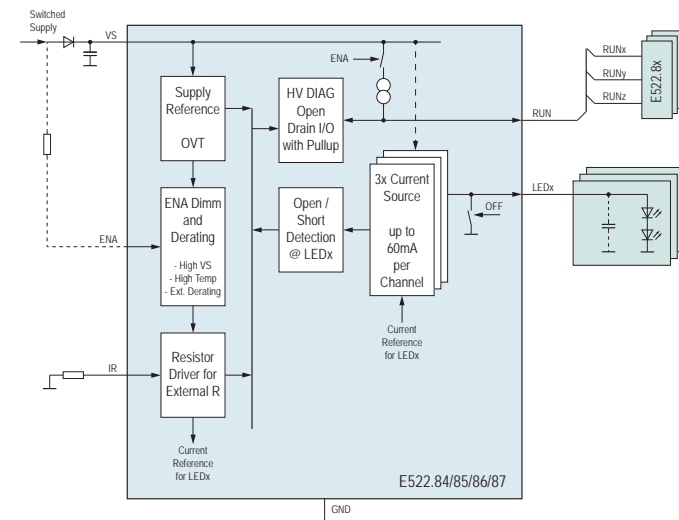

Triple Linear LED Controller (14 to 55mA) | E522.90-93

Key Features

- Operating input voltage range 5V to 25V, max. 40V
- Three independent high-side Current Sources (3*55mA)
- Parallel Operation for up to 165mA
- Low Power Standby / Sleep Mode
- Thermal Management Option per Channel
- External Reference Voltage / Derating Supported
- Automotive qualified (AEC-Q100)

Board

- Order No. see page 61



Applications

- Automotive LED lighting application
Rear Lamp (e.g. Brake Lamp, Reverse Light, Back Up Light, Rear Fog Light, Rear Light Module)
- Driving of OLEDs in cathode to GND topology

Packages

- SOIC16N-EP

Application Diagram

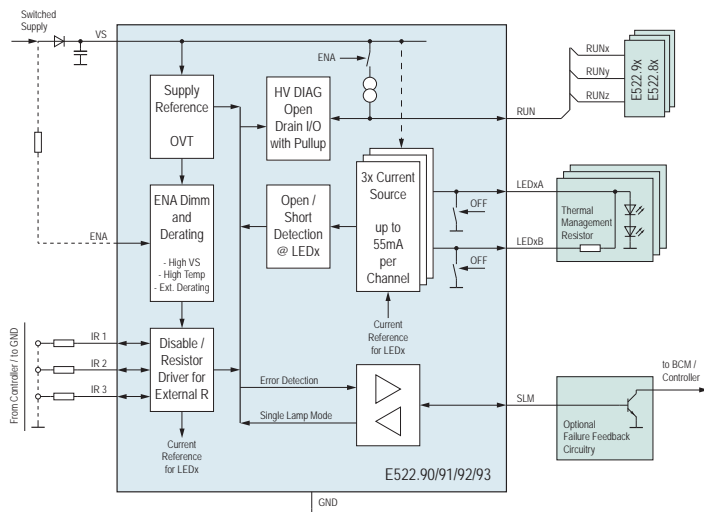

8 Channel LED Driver with I²C Interface | E522.46

Key Features

- Input voltage range 3.3V to 32V (max. 42V)
- 8-channel I²C programmable linear high side driver
- Parallel output operation for up to 200mA
- 8Bit adjustable LED master current 1mA to 26.5mA
- 8Bit PWM based LED luminous intensity level for LED binning calibration
- Global PWM and configurable analog dimming
- Configuration storable in integrated EEPROM
- Automotive qualified (AEC-Q100)

Board

- Order No. see page 60



Applications

- Automotive LED lighting
- Multi-channel panel applications
- Low current interior lighting
- Dynamic rear light functions
- LED background lighting
- Driving of OLEDs in cathode to GND topology

Packages

- DFN18L5040

Application Diagram

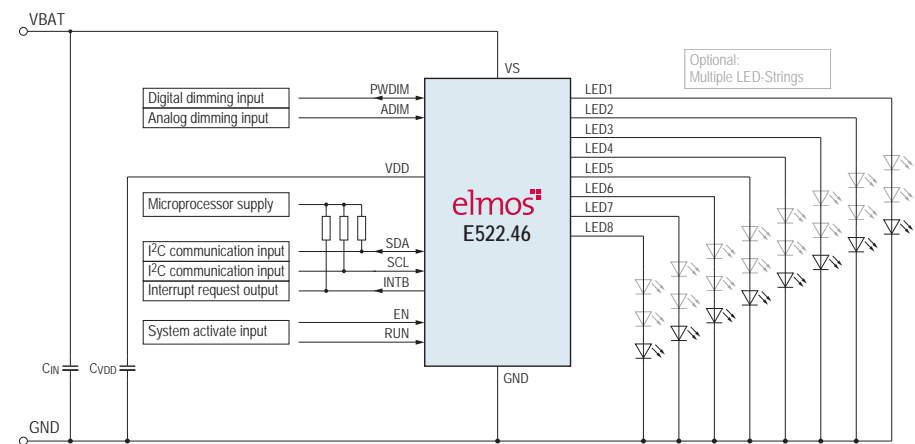

16 Channel LED Driver with I²C Interface | E522.48

Key Features

- Fast I²C bus interface for dynamic LED control
- 16 PWM generators with 10bit resolution
- 16 programmable LED drivers up to 100mA
- PWMIN interface with fallback data
- 10bit ADC for LED open, short and system diagnosis
- LED channel individual bin class brightness correction
- Single lamp mode behaviour option
- Developed according ISO26262 up to ASIL B

Board

- Order No. see page 60



Applications

- Automotive interior and exterior light systems
- General LED Applications
- High speed LED light animations

Packages

- QFN32L6

Application Diagram

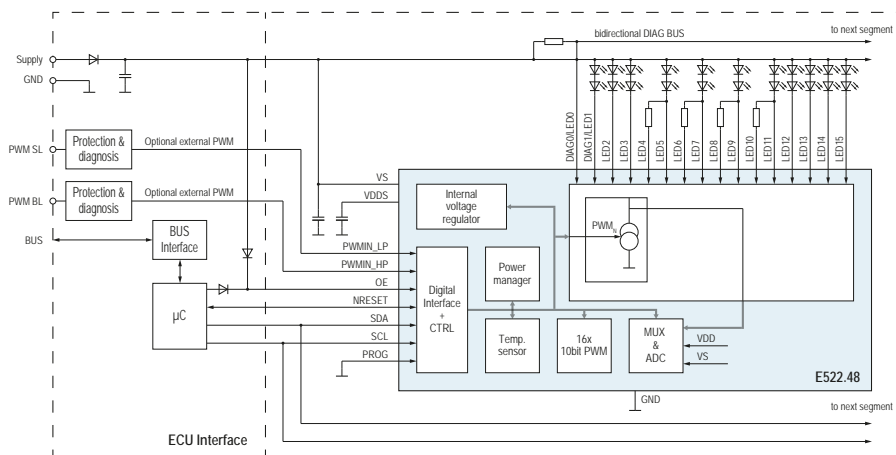

16 Channel LED Driver with Diff. Bus Interface | E522.49

Key Features

- Fast differential bus interface for dynamic LED control
- 16 PWM generators with 10bit resolution
- 16 programmable LED drivers up to 100mA
- PWMIN interface with fallback data
- 10bit ADC for LED open, short and system diagnosis
- LED channel individual bin class brightness correction
- Single lamp mode behaviour option
- Developed according ISO26262 up to ASIL B

Board

- Order No. see page 60



Applications

- Automotive interior and exterior light systems
- General LED Applications
- High speed LED light animations

Packages

- QFN32L6

Application Diagram

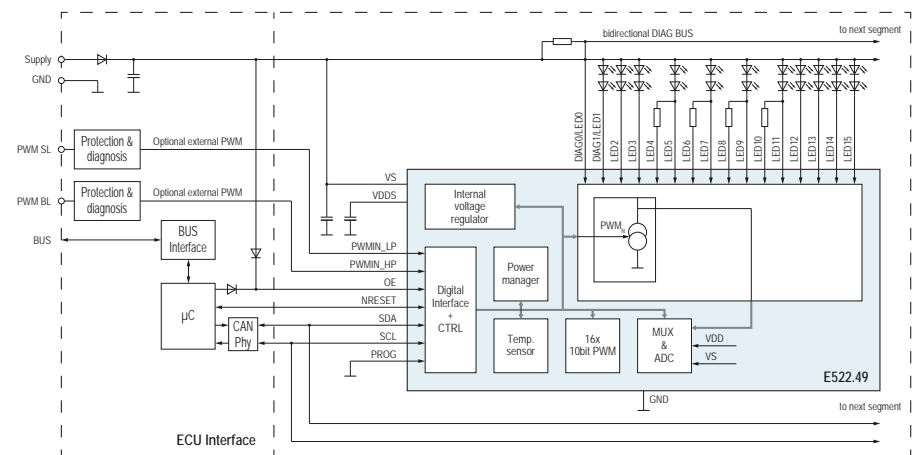

1 Channel Switched-Mode Constant Current LED Controller | E522.31/33

Key Features

- 5.0V to 55V input, up to 80V boosted output voltage
- Boost-to-GND, Boost-to-Battery and SEPIC topologies supported
- Constant current regulation
- Analog dimming and digital dimming 3000:1 at 100Hz PWM
- Advanced In-System diagnostics (e.g. GND loss, output-overload and highside-feedback diagnostics)
- Very low sleep mode currents of typ. 8 μ A
- Automotive qualified (AEC-Q100)

Board

- Order No. see page 60



Applications

- Automotive interior and exterior light systems
- General LED Applications
- High speed LED light animations

Packages

- QFN32L5

Application Diagram

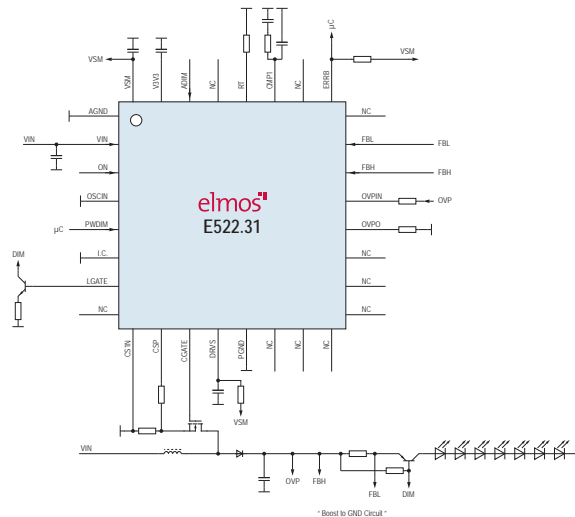

2 Channel Switched-Mode Constant Current LED Controller | E522.32/34

Key Features

- 5.0V to 55V input, up to 80V boosted output voltage
- Boost-to-GND, Boost-to-Battery and SEPIC topologies supported
- Constant current regulation
- Analog dimming and digital dimming 3000:1 at 100Hz PWM
- Advanced In-System diagnostics (e.g. GND loss, output-overload and highside-feedback diagnostics)
- Very low sleep mode currents of typ. 8 μ A
- PIN compatible to E522.31/33
- Automotive qualified (AEC-Q100)

Board

- Order No. see page 60



Applications

- Automotive LED lighting applications
- Exterior LED lighting
- TFT backlighting
- General current driven applications

Packages

- QFN32L5

Application Diagram

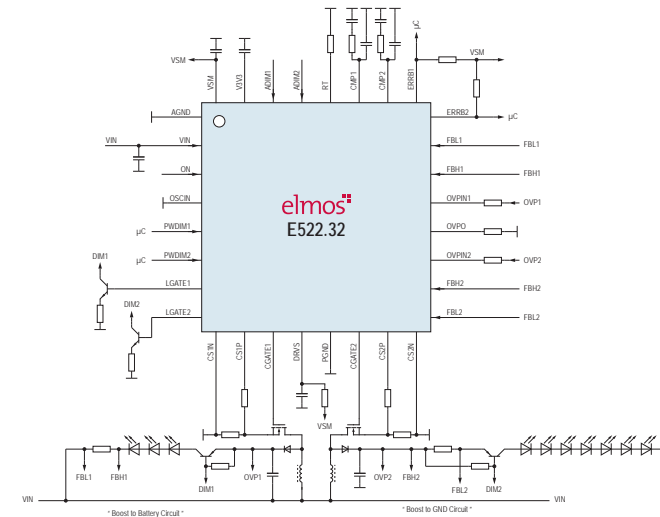

Power Management - DC/DC Converters

Automotive

Part No. / Description	I _{MAX}	Efficiency	V _{SUPPLY}	V _{OUT}	Package	Comment / Converter Topology
E522.01 Low Quiescent Current PFM Step Down Converter (5V/500mA)	500mA	>90%	4.5V to 40V	5V	QFN20L4 */ TSSOP16	<ul style="list-style-type: none"> ▪ Idle current of 12µA typ. ▪ Sleep current of 8µA typ. ▪ Input voltage up to 40V ▪ Up to 100% duty cycle ▪ Undervoltage lockout
E522.02 Low Quiescent Current PFM Step Down Converter (3.3V/500mA)	500mA	>90%	4.5V to 40V	3.3V	QFN20L4 */ TSSOP16	<ul style="list-style-type: none"> ▪ Idle current of 12µA typ. ▪ Sleep current of 8µA typ. ▪ Input voltage up to 40V ▪ Up to 100% duty cycle ▪ Undervoltage lockout
E522.03 Low Quiescent Current PFM Step Down Converter (5V/350mA)	350mA	>90%	4.5V to 40V	5V	QFN20L4 */ TSSOP16	<ul style="list-style-type: none"> ▪ Idle current of 12µA typ. ▪ Sleep current of 8µA typ. ▪ Input voltage up to 40V ▪ Up to 100% duty cycle ▪ Undervoltage lockout
E522.04 Low Quiescent Current PFM Step Down Converter (3.3V/350mA)	350mA	>90%	4.5V to 40V	3.3V	QFN20L4 */ TSSOP16	<ul style="list-style-type: none"> ▪ Idle current of 12µA typ. ▪ Sleep current of 8µA typ. ▪ Input voltage up to 40V ▪ Up to 100% duty cycle ▪ Undervoltage lockout
E522.05 Low Quiescent Current PFM Step Down Converter (Adjustable Voltage/500mA)	500mA	>90%	4.5V to 40V	1.5V to 40V	QFN20L4 */ TSSOP16	<ul style="list-style-type: none"> ▪ Idle current of 12µA typ. ▪ Sleep current of 8µA typ. ▪ Input voltage up to 40V ▪ Up to 100% duty cycle ▪ Undervoltage lockout
E522.06 Low Quiescent Current PFM Step Down Converter (Adjustable Voltage/350mA)	350mA	>90%	4.5V to 40V	1.5V to 40V	QFN20L4 */ TSSOP16	<ul style="list-style-type: none"> ▪ Idle current of 12µA typ. ▪ Sleep current of 8µA typ. ▪ Input voltage up to 40V ▪ Up to 100% duty cycle ▪ Undervoltage lockout

* QFN both with/without wettable Flanks

Part No. / Description	I _{MAX}	Efficiency	V _{SUPPLY}	V _{OUT}	Package	Comment / Converter Topology
E522.31/33 1 Channel Switched-Mode Constant Current LED Controller	-	>90%	5V to 55V	up to 80V	QFN32L5	<ul style="list-style-type: none"> DC/DC Boost, SEPIC, Buck-Boost or Buck incl.: charge pump for reverse polarity and HS Switch
E522.32/34 2 Channel Switched-Mode Constant Current LED Controller	-	>90%	5V to 55V	up to 80V	QFN32L5	<ul style="list-style-type: none"> DC/DC Boost, SEPIC, Buck-Boost or Buck incl.: charge pump for reverse polarity and HS Switch
E522.10 Low Quiescent Current PFM Step Down Converter	2000mA	>90%	3.8V to 40V	Adjustable with 200 / 800mV Vref	QFN20L4* / SOIC8-EP	<ul style="list-style-type: none"> Idle current of 15µA typ. Sleep current of 10µA typ. Input voltage up to 40V Up to 100% duty cycle Undervoltage lockout
E522.41/43 Automotive USB 2.0 Supply with Data Line Protection and I ² C Interface	2500mA	>90%	6.0V to 32V (tran. 42V)	5V	QFN20L5	<ul style="list-style-type: none"> Fixed frequency 250kHz..2MHz ± 25% synchronizable Fixed 5V ±3% USB Bus voltage with seven programmable negative resistance adjustments SDP, BC 1.2 CDP, DCP and individual USB charging modes

* QFN both with/without wettable Flanks

Low Quiescent Current PFM Step Down Converters | E522.01-06

Key Features

- Voltage range 4.3V to 40V
- PFM operation up to 1.33MHz
- Up to >92% efficiency
- Very low 8µA sleep mode current
- Ultra low 12µA standby current
- 100% duty cycle capability
- Junction temperature range -40°C to +150°C
- Automotive qualified (AEC-Q100)

Board

- Order No. see page 61



Applications

- Supply of
 - Microcontroller systems
 - Automotive telematics, dashboards
 - Partial networking systems
 - Peripheral control systems

Packages

- QFN20L4
- TSSOP16

Application Diagram

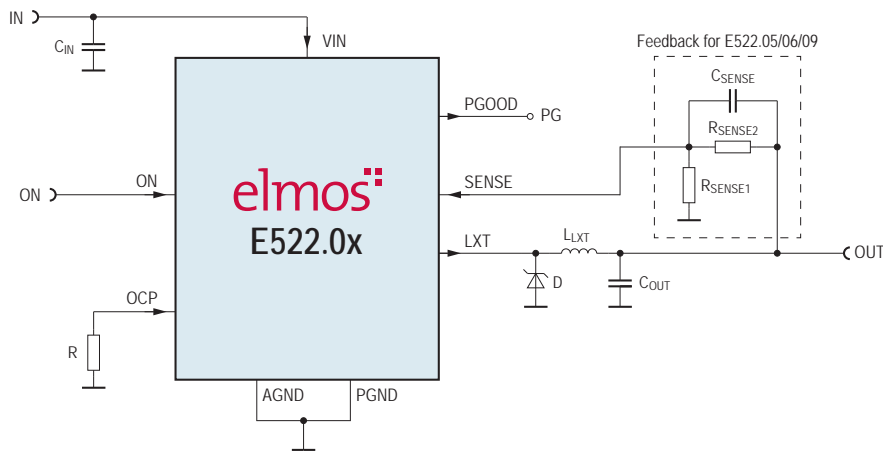

Low Quiescent Current PFM Step Down Converters | E522.10

Key Features

- Voltage range 3.6V to 40V
- PFM operation up to 1.33MHz
- Up to >92% efficiency
- Very low 10µA sleep mode current
- Idle current 15µA
- 100% duty cycle capability
- Junction temperature range -40°C to +150°C
- Automotive qualified (AEC-Q100)

Board

- Order No. see page 61



Applications

- Supply of
 - Microcontroller systems
 - Automotive telematics, dashboards
 - Partial networking systems
 - Peripheral control systems

Packages

- QFN20L4
- SOIC8-EP

Application Diagram

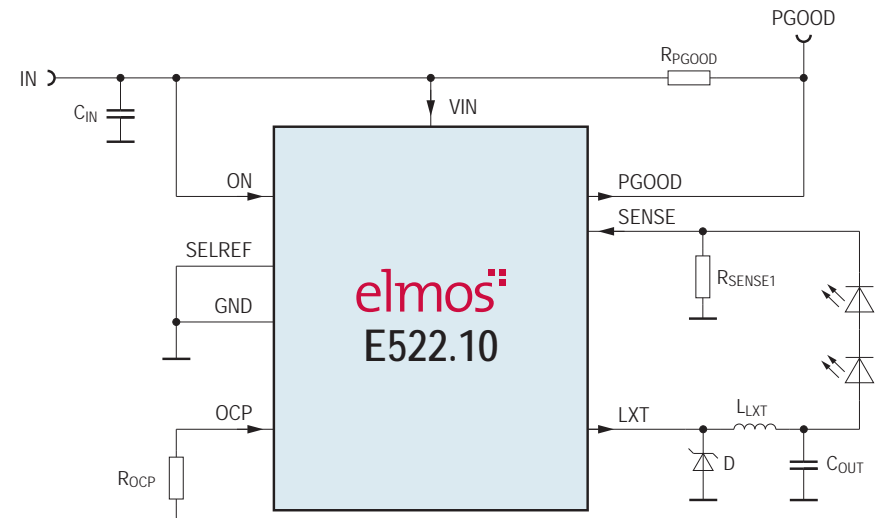

Automotive USB 2.0 Supply w. Data Line Protection a. I²C Interface | E522.41/43

Key Features

- Wide input voltage range from 6V to 32V (tran. 42V)
- PWM Step-Down converter 250kHz, 500kHz, 1MHz or 2MHz
- Advanced PWM voltage regulation with 100% duty cycle
- Fixed 5V±3% USB BUS voltage, w. negative resistance adjustm.
- Output currents of 0.5/1A/1.5A/2.5A w. fixed limits or regulation
- ±25% synchronizable to center frequencies
- Wake-on USB functionality
- Automotive qualified (AEC-Q100)

Board

- Order No. see page 61



Applications

- Automotive infotainment and navigation
- USB-Chargers

Packages

- QFN20L5

Application Diagram

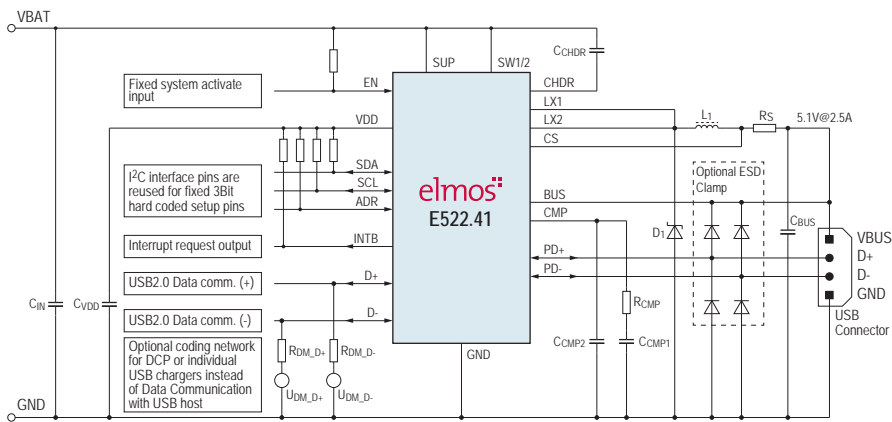

Power Management - LDO

Part No. / Description	Recommended I_{MAX}	V_{SUPPLY}	V_{OUT}	Package	Comment / Converter Topology
E522.40 Dual LDO with Diagnosis	2x 200mA	4.5V to 25V	3.3V to V_{BAT}	QFN20L5	<ul style="list-style-type: none"> ■ ADC capturing of relevant voltages and currents ■ I²C interface for programming and monitoring ■ Multiple protection features
E522.44 Triple Antenna Supply	1x 350mA 1x 200mA 1x 80mA	4.5V to 40V	3V to 40V	DFN18L5040-SLP	<ul style="list-style-type: none"> ■ Parallel regulator operation ■ ADC capturing of relevant voltages and currents ■ I²C interface for programming and monitoring ■ Multiple protection features

Dual LDO with Diagnosis | E522.40

Key Features

- Input voltage range from 4.5V to 25V
- Two accurate output voltages from 3.3V to V_{BAT}
- Up to 200mA load current with integrated current limit
- Programmable overcurrent and open load detection levels
- Over voltage, overtemperature a. output voltage error protection
- Open-drain error flag for interrupt generation
- 8bit ADC samples system voltages and current ranges
- Optional external NPN pre-regulator
- Programmable comparator for additional control functions

Applications

- Automotive antenna modules
- Navigation and radio units
- General voltage regulator applications

Board

- Order No. see page 62



Packages

- QFN20L5

Application Diagram

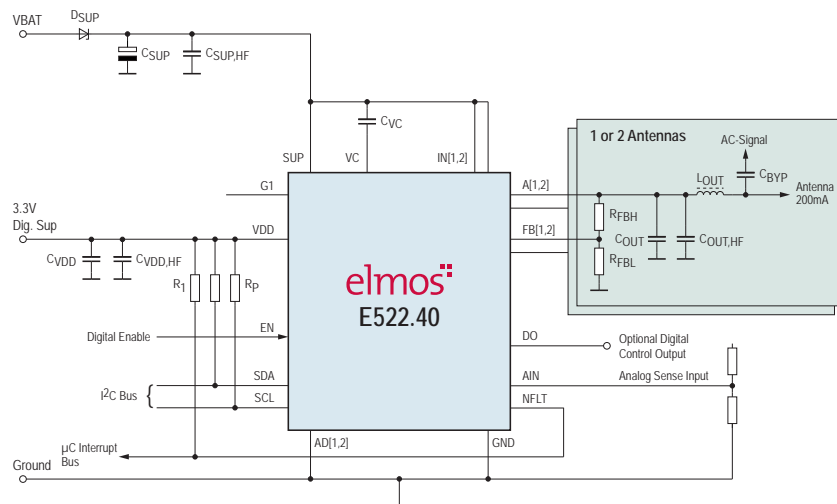

Triple Antenna Supply | E522.44

Key Features

- Input voltage range from 4.5V to 40V
- Resistor programmable output voltage
- Output voltage range 3 to 40V
- Three channels with up to 350mA output current capability
- Parallel regulator operation
- Switch mode operation Output current and voltage sensing
- Thermal protection and temperature monitoring
- Over current/open load protection

Applications

- Automotive Antenna Modules
- Navigation and Radio Units
- General Voltage Regulator Applications
- Sensors

Board

- Order No. see page 62



Packages

- DFN18L5040-SLP

Application Diagram

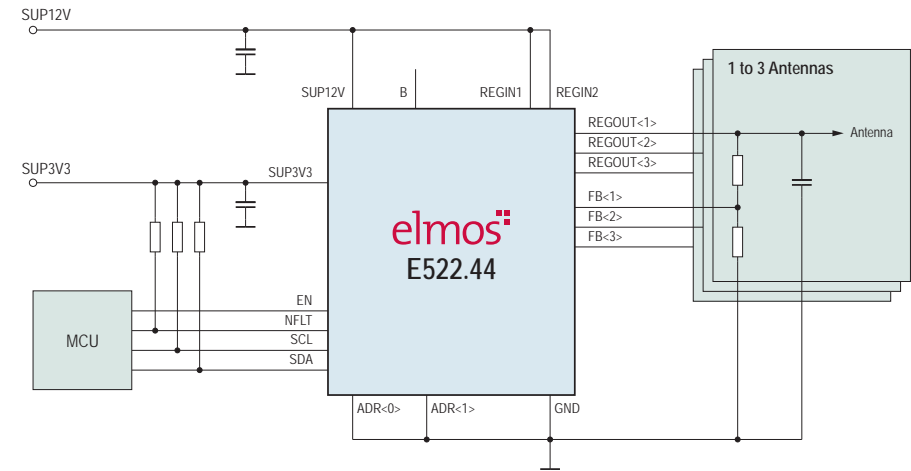

Power Management - Boards

LED

Part No.	Description	Board type	Order No.
E521.31	Evaluation Board (without CPU boards)	Evaluation Kit	K52131-0001
E521.31	Adapter board	CPU Board	K52131-0002
E521.31	Mini-Demo	Demoboard	K52131-0003
E521.31	Evaluation Board Autoaddressing	Evaluation Board	K52131-0004
E521.31	MiniMux (Mini-Demo Multiplexer)	MiniMux (Mini-Demo Multiplexer)	K52131-0005
E521.31	Piggy Board: RBG Demonstrator	Demoboard	K52131-0006
E521.31	MiniMux CAN (Mini-Demo Multiplexer)	Demoboard	K52131-0007
E521.36	Evaluation Board	Evaluation Kit	K52136-0001
E521.36	CPU Board with removable socket ENPLAS	Evaluation Kit	K52136-0002
E521.36	CPU Board without removable socket	Evaluation Kit	K52136-0003
E521.36	Mini-Demo	Demo Board	K52136-0004
E521.36	CPU Board RAM Device	Development Board	K52136-0005
E521.36	Mini-Demo ENPLAS	Demoboard	K52136-0006
E521.36	Mini-Demo RAM	Demoboard	K52136-0007
E521.36	Mini-Demo with MiniMux SW	Demoboard	K52136-0008
E522.46	8 Channel LED Driver with I ² C Interface	Evaluation Kit	K52246-0002
E522.48	16 Channel LED Driver with I ² C Interface	Evaluation Board	K52248-0001
E522.48	16 Channel LED Driver with I ² C Interface	Adapter board E522.48	K52248-0002
E522.48	16 Channel LED Driver with I ² C Interface	Adapter board with Exchange socket	K52248-0003
E522.48	16 Channel LED Driver with I ² C Interface	LED Board	K52295-0004
E522.48	16 Channel LED Driver with I ² C Interface	Supply Board	K52248-0008
E522.48	16 Channel LED Driver with I ² C Interface	Masterboard	K52248-0009
E522.49	16 Channel LED Driver with Differential Interface + UART	Evaluation Board	K52249-0001
E522.49	16 Channel LED Driver with Differential Interface + UART	Adapter board E522.49	K52249-0002
E522.49	16 Channel LED Driver with Differential Interface + UART	Adapter board with Exchange socket	K52249-0003
E522.49	16 Channel LED Driver with Differential Interface + UART	LED Board	K52249-0004
E522.49	16 Channel LED Driver with Differential Interface + UART	Supply Board	K52248-0008
E522.49	16 Channel LED Driver with Differential Interface + UART	Masterboard	K52249-0009

LED

Part No.	Description	Board type	Order No.
E522.81	LED Slaveboard Red (3x3 red)	Demoboard	K52281-0001
E522.83	LED Slaveboard RGB (3x red, 3x green, 3x blue)	Demoboard	K52283-0001
E522.8x	Master Controllerboard	Demoboard	K5228x-0001
E522.9x	LED Slaveboard Red (3x3 red)	Demoboard	K5229X-0001

DC/DC Converter

Part No.	Description	Board type	Order No.
E522.01	Low Quiescent Current PFM Step Down Converter (5V/500mA)	Demoboard	K52201-0001
E522.02	Low Quiescent Current PFM Step Down Converter (3.3V/500mA)	Demoboard	K52202-0001
E522.03	Low Quiescent Current PFM Step Down Converter (5V/350mA)	Demoboard	K52203-0001
E522.04	Low Quiescent Current PFM Step Down Converter (3.3V/350mA)	Demoboard	K52204-0001
E522.05	Low Quiescent Current PFM Step Down Converter (Adjustable Voltage/500mA)	Demoboard	K52205-0001
E522.10	Low Quiescent Current PFM Step Down Converter (2A Buck Converter)	Demoboard Adjustable High Frequency Low Power 2A Step Down Converter (V-Demo)	K52210-0001
E522.10	Low Quiescent Current PFM Step Down Converter (2A Buck Converter)	Demoboard Adjustable High Frequency Low Power 2A Step Down Converter for Constant Current Application (CC-Demo)	K52210-0002
E522.10	Low Quiescent Current PFM Step Down Converter (2A Buck Converter)	Demoboard High Frequency Low Power Adjustable Voltage 2A Step Down / Step up Converter (ZETA-Topology)	K52210-0003
E522.10	Low Quiescent Current PFM Step Down Converter (2A Buck Converter)	Demoboard High Frequency Constant Current (350mA) Step down / Step up Converter (ZETA-Topology)	K52210-0004
E522.31	EMV Boost to Battery Converter (650mA)	Demoboard	K52231-0002
E522.31	EMV Boost to GND Converter (500mA)	Demoboard	K52231-0003
E522.31	Sepic Converter (750mA)	Demoboard	K52231-0004
E522.31	Buck to Battery Converter (3A)	Demoboard	K52231-0005
E522.32	Headlight LED Demo (2x Boost to Battery Topology) for High Beam, Low Beam (1A) and Daytime Running Light (750mA)	Demoboard	K52232-0003
E522.32	Buck to Battery dual phase Converter (6A)	Demoboard	K52232-0004

LDO

Part No.	Description	Board type	Order No.
E522.40	Dual LDO with Diagnosis	Evaluation Board	K52240-0001
E522.44	Tripple Antenna Supply	Evaluation Board	K52244-0001



ed

Dynamic Rear Light



Interface - PSI5 Transceiver

Part No. / Description	V _{SUPPLY}	I _q (mA)	ESD (kV)	Bitrate	Package
E521.40 2-Channel Multi-Mode PSI5 Transceiver	5.3V to 19V	1	4	up to 189 Kbit/s	QFN20L5 SOIC20
E521.41 4-Channel Multi-Mode PSI5 Transceiver	5.3V to 19V	2	4	up to 189 Kbit/s	QFN20L5 SOIC20
E981.07 2-Channel Sensor Interface PSI5	8.5V to 25V	1	4	125 Kbit/s	QFN20L5
E981.08 4-Channel Sensor Interface PSI5	8.5V to 25V	1	4	125 Kbit/s	QFN32L7

2-/4-Channel Multi-Mode PSI5 Transceiver | E521.40/41

Key Features

- Provides two respective, four master channels compliant with PSI5 standard v1.3 and v2.1
- Support 125 Kbit/s, 189 Kbit/s, synchronous and asynchronous modes
- Internal sync-voltage generation
- Programmable bus-voltage 4.6V to 11V
- Automatic threshold adaption to sensor quiescent current
- Reverse polarity protected bus outputs up to 40V

Board

- Order No. see page 76



Applications

- Safety (airbag) control systems
- Powertrain control systems
- Vehicle dynamics control system

Packages

- QFN20L5
- SOIC20

Application Diagram

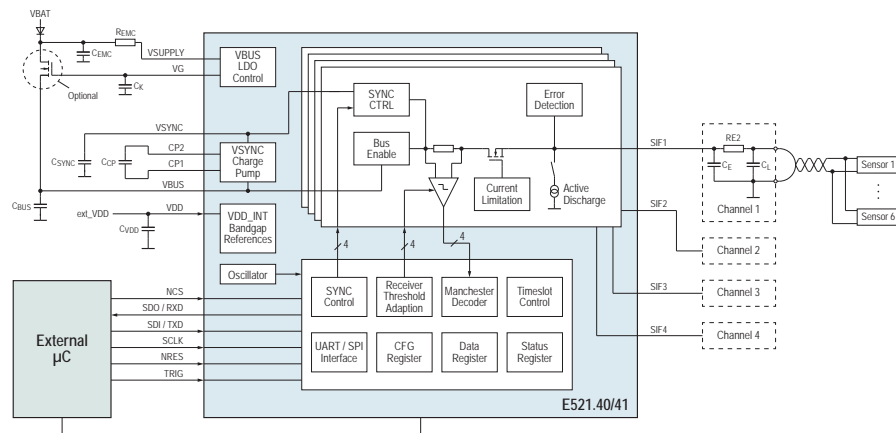

2-/4-Channel Sensor Interface PSI5 | E981.07/08

Key Features

- Two respective, four independent operating channels
- Device parameters comply with PSI5-P10P-500/3L (PSI5 spec 1.3)
- Applicable for parallel and universal mode (standard) as well as daisy chain mode (increased)
- Channel output short circuit protected against 40V and GND

Board

- Order No. see page 76



Applications

- Passenger restraint systems

Packages

- QFN32L7
- QFN20L5 respective

Application Diagram

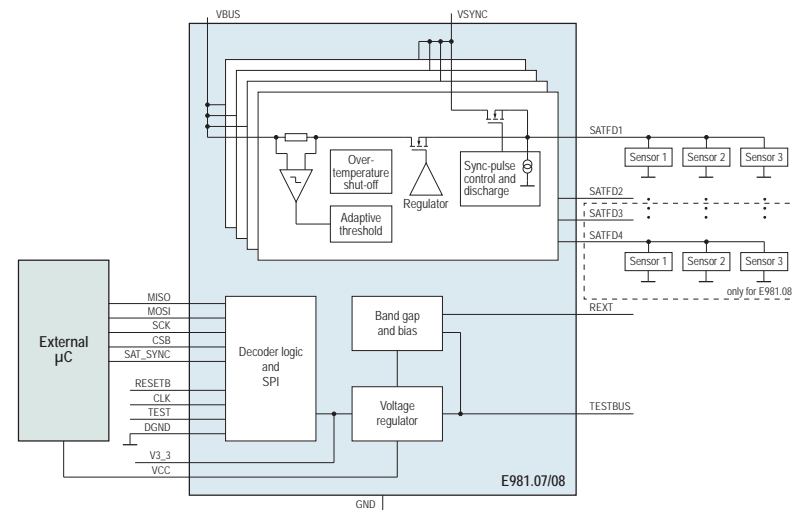

Interface - CAN Transceiver and System Basis Chip

Part No. / Description	Interface	V _{SUPPLY}	I _q (μA)	V _{DD}	ESD (kV)	Bitrate	Package
E521.21 CAN-FD SBC with DC/DC and Highside Switch	11898-2/-5	5.5V to 40V	30	3.3V	8	up to 2 Mbit/s	QFN32L5
E521.22 CAN-FD SBC with LDO and Highside Switch	11898-2/-5	5.5V to 40V	30	3.3V	8	up to 2 Mbit/s	QFN32L5
E521.23 CAN-FD SBC with DC/DC and Highside Switch	11898-2/-5	5.5V to 40V	30	5V	8	up to 2 Mbit/s	QFN32L5
E521.24 CAN-FD SBC with LDO and Highside Switch	11898-2/-5	5.5V to 40V	30	5V	8	up to 2 Mbit/s	QFN32L5

CAN-FD SBC with DC/DC and Highside Switch | E521.21/23

Key Features

- Voltage regulator 3.3V/5V
- DC/DC buck converter up to 200mA
- HS-CAN-FD transceiver (ISO 11898-2:2016) up to 2 Mbit
- Charge pump for external active reverse polarity protection
- Sensor supply voltage regulator 5V/50mA
- Integrated high-side switch typ. 0.15Ω with current sense
- Gate control for external high-side driver (NMOS power FET)



Applications

- ECUs connected to the CAN bus
- Front light modules
- Body computer

Packages

- QFN32L5

Application Diagram

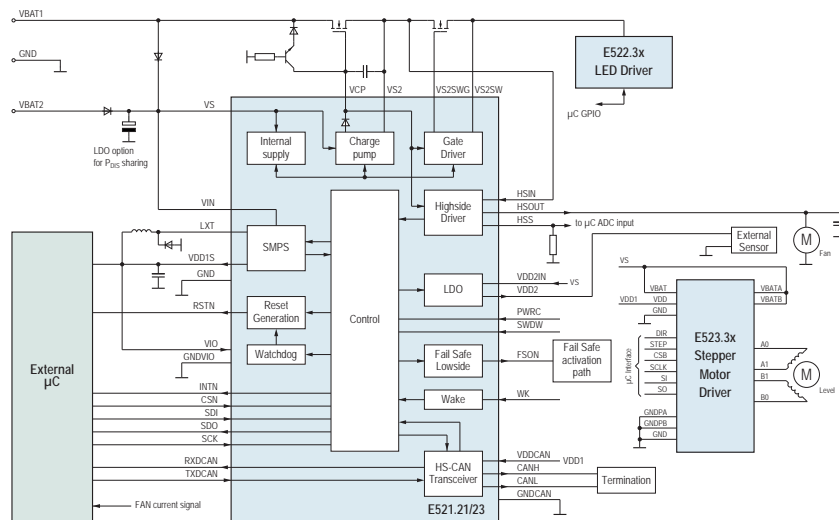

CAN-FD SBC with LDO and Highside Switch | E521.22/24

Key Features

- Voltage regulator 3.3V/5V
- Linear Regulator up to 200mA
- HS-CAN-FD transceiver (ISO 11898-2:2016) up to 2 Mbit
- Charge pump for external active reverse polarity protection
- Sensor supply voltage regulator 5V/50mA
- Integrated high-side switch typ. 0.15Ω with current sense
- Gate control for external high-side driver (NMOS power FET)



Applications

- ECUs connected to the CAN bus
- Front light modules
- Body computer

Packages

- QFN32L5

Application Diagram

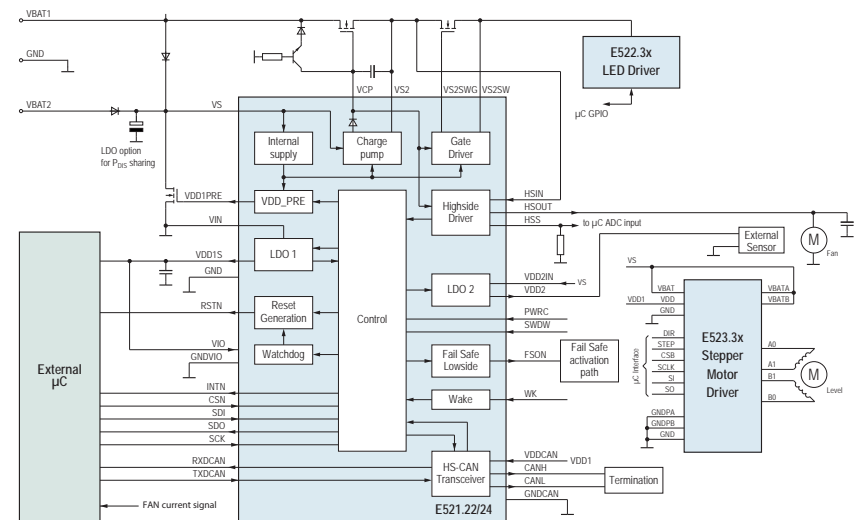

Interface - LIN Transceiver and System Basis Chip

LIN Transceiver and System Basis Chip

Part No. / Description	Interface	V _{SUPPLY}	I _q (μA)	V _{DD}	ESD (kV)	Bitrate	Package
E521.25 LIN SBC with Voltage Regulator	LIN 2.1 LIN 2.2 SAE-J2602 ISO9141	5V to 28V	10	3.3V	8	up to 20 Kbit/s	QFN20L5

LIN RGB Controller

Part No. / Description	Interface	V _{SUPPLY}	I _q (μA)	V _{DD}	ESD (kV)	Bitrate	Package
E521.31 LIN Controller with Position Detection	*SoC LIN 2.1 LIN 2.2 SAE-J2602	5V to 28V, max. 40V	10	5V	8	up to 20 Kbit/s	QFN32L5
E521.36 RGB LIN Controller with Current Source	*SoC LIN 2.1 LIN 2.2 SAE-J2602	5V to 28V, max. 40V	15	-	8	up to 20 Kbit/s	SOIC8-EP

*SoC System-on-a-Chip | with integrated microcontroller

LIN SBC with Voltage Regulator | E521.25

Key Features

- LIN transceiver, V 2.1, V2.2 SAE-J2602, ISO9141
- Operating range VS 5V up to 28V
- Limited functional range 3.8V up to 40V
- Typ. 10µA sleep current consumption
- Very low BUS leakage current
- Reset generation
- µC window watchdog
- Internal 1:6 Voltage Divider for V_{BAT} Sensing
- 3.3V (2%) in active mode, (5%) in standby mode



Applications

- Smart applications connected to the LIN bus

Packages

- QFN20L5

Application Diagram

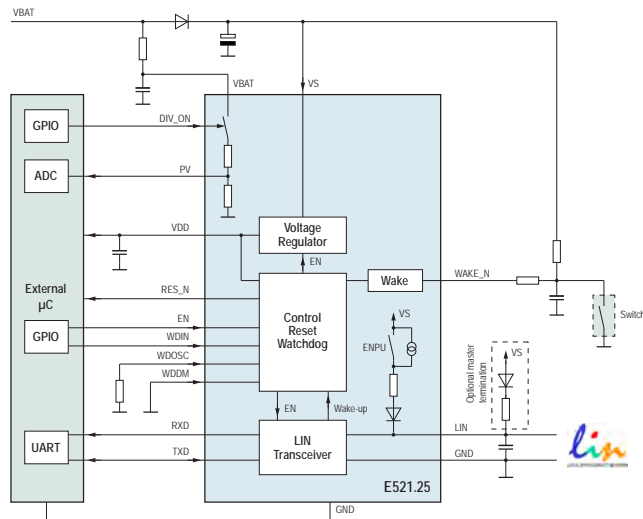

LIN Controller with Position Detection | E521.31

Key Features

- Transceiver compliant with LIN 2.1, LIN 2.2 and SAE-J2602
- Linear voltage regulator with 5V, 100mA
- State of the art 16bit μ C
- Integrated 32kbyte Flash (Flexible EEPROM emulation by SW)
- 4x PWM driven High Side drivers with 5V and up to 50mA each
- μ C window watchdog
- ADC 12bit accuracy

Board

- Order No. see page 76



Applications

- Interior light modules

Packages

- QFN32L5

Application Diagram

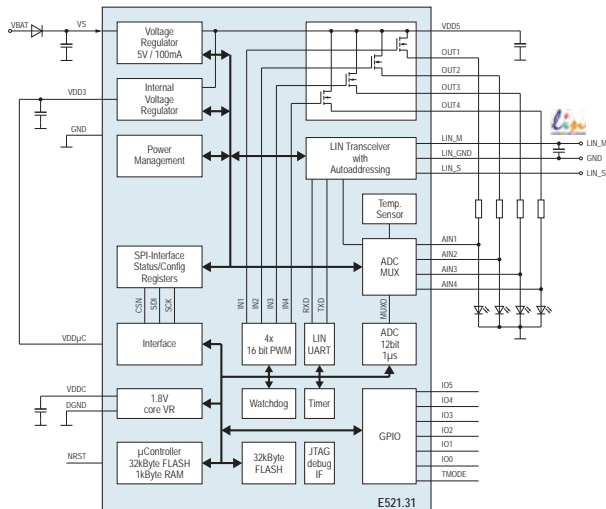

RGB LIN Controller with Current Source | E521.36

Key Features

- Input voltage range 5V to 28V
- Integrated 16 bit microcontroller
- 32kByte OTP
- 128Byte customer usable non-volatile memory
- 1.25kByte RAM 16kByte SysROM containing standard LIN routines and boot loader
- 4 PWM generators with 48MHz and 16bit resolution
- 2 Timers with 16bit resolution
- 3 LED drivers with currents up to 40mA and fast slopes

Board

- Order No. see page 76



Applications

- Interior light modules
- Ambient lighting

Packages

- SOIC8-EP

Application Diagram

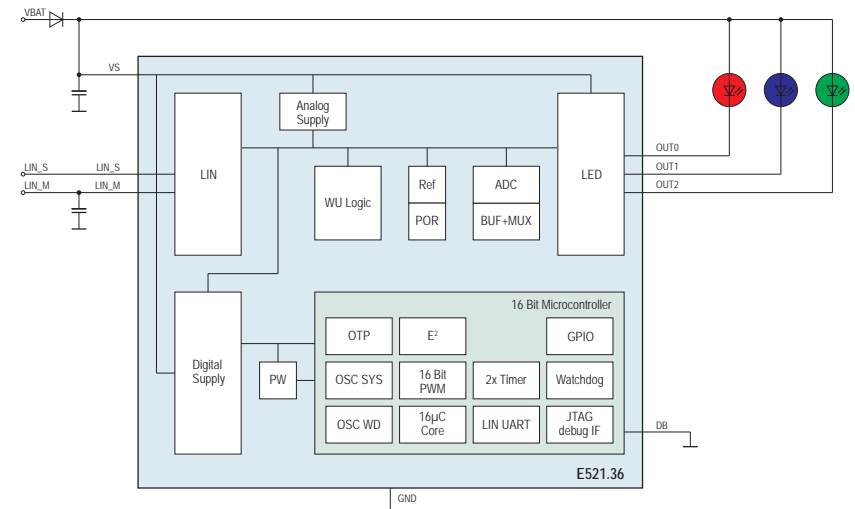



elmos[™]
Innovation Matters

Open

Welcome

P

LED Ambient Light

elmos

Interface - KNX/EIB Transceiver

Part No. / Description	V _{SUPPLY}	I _q (mA)	V _{DD}	ESD (kV)	Bitrate	Package
E981.03 KNX/EIB Transceiver	19V to 33V	1.9 ¹⁾	3.3V/5V	2	9.6 Kbit/s 19.2 Kbit/s 115.2 Kbit/s	QFN32L7
E981.23 KNX-Transceiver with Hardware Current Programming	19V to 33V	1.9 ¹⁾	3.3V/5V	2	9.6 Kbit/s 19.2 Kbit/s 115.2 Kbit/s	QFN32L7
E981.33 KNX-Bit Transceiver with Hardware Current Programming	19V to 33V	1.9 ¹⁾	3.3V/5V	2	9.6 Kbit/s	QFN32L7

¹⁾ Typical value for V_{DD} = 3.3V

KNX/EIB Transceiver | E981.03

Key Features

- KNX/EIB transceiver, certified according to KNX TP1-256
- Analog mode supported
- Configurable bus current (maximum current and slew rate)
- Voltage regulators
 - 20V: current capability up to 20mA
 - 3.3V or 5V DC/DC converter: current capability up to 70mA
- UART host interface (data rate up to 115.2 Kbit/s)
- SPI for configuration (optional)

Board

- Order No. see page 77



Applications

- Sensors, actuators, routers, gateways, Bus-powered or externally supplied
- Security applications

Packages

- QFN32L7

Application Diagram

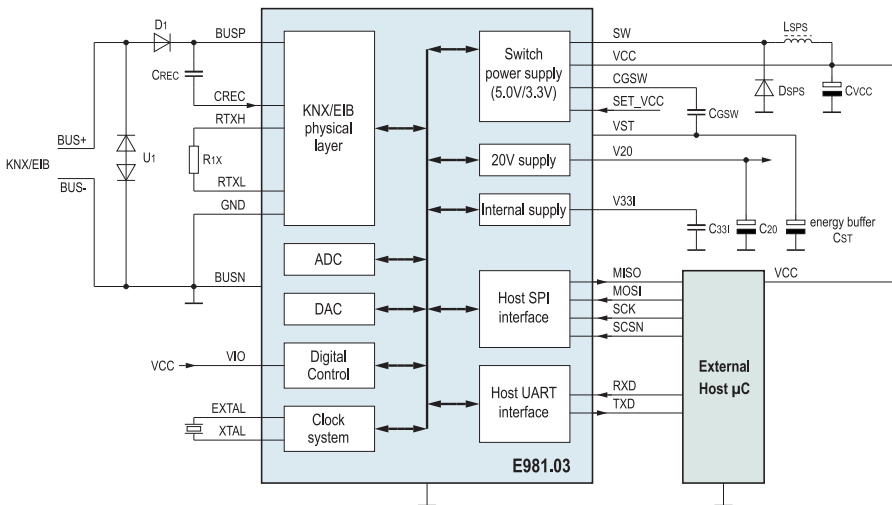

KNX-Transceiver with Hardware Current Programming | E981.23

Key Features

- KNX/EIB transceiver, certified according to KNX TP1-256
- Analog mode supported
- Configuration pins for bus current & slope
- Configuration pins for external clock frequency 8 or 7.3728 MHz
- Further configuration and diagnosis via UART
- Voltage regulators
 - 20V: current capability up to 25mA
 - 3.3V or 5V DC/DC converter: current capability up to 100mA

Board

- Order No. see page 77



Applications

- Sensors, actuators, routers, gateways, Bus-powered or externally supplied
- Security applications

Packages

- QFN32L7

Application Diagram

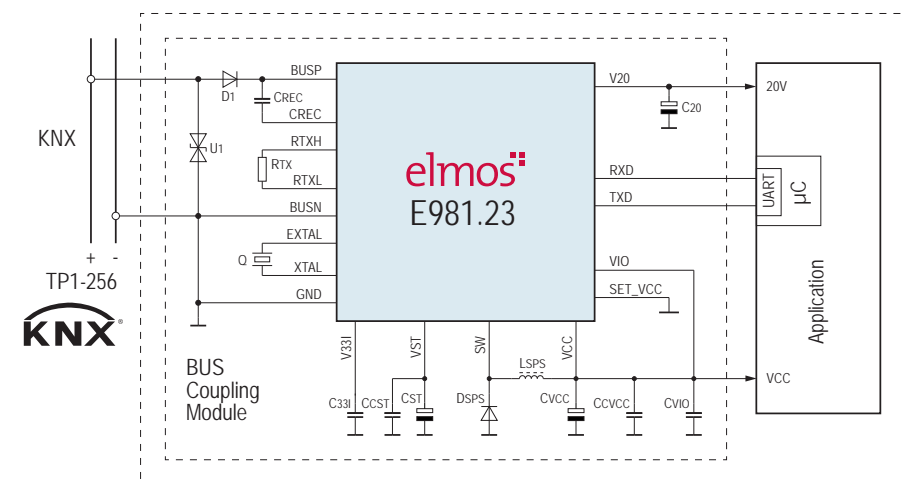

KNX-Bit Transceiver with Hardware Current Programming | E981.33

Key Features

- KNX/EIB transceiver, certified according to KNX TP1-256
- Analog mode supported
- Configuration pins for bus current & slope
- Further configuration and diagnosis via bit transceiver
- Voltage regulators
 - 20V: current capability up to 25mA
 - 3.3V or 5V DC/DC converter: current capability up to 100mA

Board

- Order No. see page 77



Applications

- Sensors, actuators, routers, gateways, Bus-powered or externally supplied
- Security applications

Packages

- QFN32L7

Application Diagram

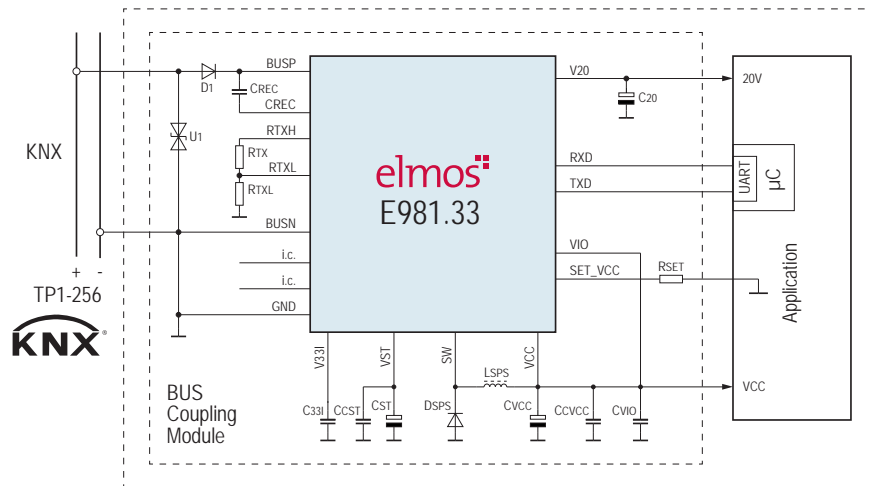

	E981.03	E981.23	E981.33
KNX EIB transceiver analog mode	■	■	■
KNX EIB transceiver with medium access control	■	■	
Compatible to KNX TP1-256 supporting extended frames up to 254 Bytes payload	■	■	■
Configuration pins for bus current & slope		■	■
Configuration pins for external clock frequency 8 or 7.3728 MHz		■	
Further configuration and diagnosis via	SPI UART	UART	
UART host interface up to 115kBaud with optional CRC	■	■	
Power management functionality with host wake up on received KNX telegram content	■	■	
Buck voltage regulator for 3.3 or 5V for up to	70mA	100mA	100mA
Linear voltage regulator for 20V up to 25mA	■	■	■
Over temperature monitoring/protection	■	■	■
Operating temperature range -25°C to +85°C	■	■	■
QFN32L7 package (all pin compatible)	■	■	■

Make your home smart
with KNX network solutions



Home App

- Home
- Light Control
- Shutter Control
- Security Control
- Home Entertainment

Temperature Control

Light Switches

Interface - Boards

PSI5 Transceiver

Part No.	Description	Board type	Order No.
E521.41	4-Channel Multi-Mode PSI5 Transceiver	Demoboard	K52141-0001
E981.07	2-Channel Sensor Interface PSI5	Evaluation Board	K98107-0001
E981.07	2-Channel Sensor Interface PSI5	Adapter Board	K98107-0002

Interior Lighting & LIN Controller

Part No.	Description	Board type	Order No.
E521.31	LIN RGB Controller with Position Detection	Evaluation Board	K52131-0001
E521.31	LIN RGB Controller with Position Detection (CPU Board for K52131-0001)	CPU Board	K52131-0002
E521.31	LIN RGB Controller with Position Detection (Full Application in Small Size)	Mini-Demo	K52131-0003
E521.31	LIN RGB Controller with Position Detection (Auto-Addressing Test Board)	Evaluation Board	K52131-0004
E521.31	MiniMux (Mini-Demo Multiplexer)	Mini-Demo	K52131-0005
E521.31	RGB LIN Controller with Current Source (CPU Board with removable socket)	Evaluation Board	K52136-0001
E521.31	RGB LIN Controller with Current Source (CPU Board with removable socket ENPLAS)	CPU Board ENPLAS	K52136-0002
E521.36	RGB LIN Controller with Current Source (CPU Board without removable socket)	CPU Board	K52136-0003
E521.36	RGB LIN Controller with Current Source	Mini-Demo	K52136-0004
E521.36	RGB LIN Controller with Current Source (CPU Board RAM Device)	CPU Board	K52136-0005
E521.36	RGB LIN Controller with Current Source	Mini-Demo ENPLAS	K52136-0006
E521.36	RGB LIN Controller with Current Source	Mini-Demo RAM	K52136-0007

KNX/EIB Transceiver

Part No.	Function	Board type	Order No.
E981.03	KNX/EIB Transceiver	KNX TP Demoboard	K98103-0001
E981.03	KNX/EIB Transceiver	KNX TP 815 Evaluation Board V2	K98103-0002
E981.23	KNX/EIB Transceiver	KNX TP 815 Evaluation Board V2	K98123-0001
E981.33	KNX/EIB Transceiver	KNX TP 815 Evaluation Board V2	K98133-0001

Special Projects - Safety

Part No. / Description	V _{SUPPLY}	Interfaces / Features	μC Interface	Package
E521.40 2-Channel Multi-Mode PSI5 Transceiver	5.3V to 19V	2 PSI5 Master rev 2.1 / 1.3 Standard / fast Sync (int. Chargepump) / async	SPI (16 bit, 5MHz) / UART (16 bit, 6.4 Mbps)	QFN20L5 SOIC20
E521.41 4-Channel Multi-Mode PSI5 Transceiver	5.3V to 19V	4 PSI5 Master rev 2.1 / 1.3 Standard / fast Sync (int. Chargepump) / async	SPI (16 bit, 5MHz) / UART(16 bit, 6.4 Mbps)	QFN20L5 SOIC20
E981.07 2-Channel Sensor Interface PSI5	3.3V to 5.5V	2 PSI5 Master rev 1.3 Standard speed Sync /	SPI (16 bit, 8 MHz)	QFN20L5
E981.08 4-Channel Sensor Interface PSI5	3.3V to 5.5V	4 PSI5 Master rev 1.3 Standard speed Sync /	SPI (16 bit, 8 MHz)	QFN32L7
E981.17 4-Channel Airbag Squib Driver	4.5V to 5.5V	4 Squib HS/LS Driver LCM / HCM	SPI (8/16 bit, 8 MHz)	QFN44L7
E981.18 8-Channel Airbag Squib Driver	4.5V to 5.5V	8 Squib HS/LS Driver LCM / HCM	SPI (8/16 bit, 8 MHz)	QFN44L7
E981.20 4-Channel Squib Driver with Current Counter	4.5V to 5.5V	4 Squib HS/LS Driver LCM, HCM1 and HCM2	SPI (8/16/32 bit, 8 MHz)	QFN44L7
E981.21 8-Channel Squib Driver with Current Counter	4.5V to 5.5V	8 Squib HS/LS Driver LCM, HCM1 and HCM2	SPI (8/16/32 bit, 8 MHz)	QFN44L7

2-/4-Channel Multi-Mode PSI5 Transceiver | E521.40/41

Key Features

- Provides two respective, four master channels compliant with PSI5 standard v1.3 and v2.1
- Support 125 Kbit/s, 189 Kbit/s, synchronous and asynchronous modes
- Internal sync-voltage generationw
- Programmable bus-voltage 4.6V to 11V
- Automatic threshold adaption to sensor quiescent current
- Reverse polarity protected bus outputs up to 40V

Board

- Order No. see page 88



Applications

- Safety (airbag) control systems
- Powertrain control systems
- Vehicle dynamics control system

Packages

- QFN20L5
- SOIC20

Application Diagram

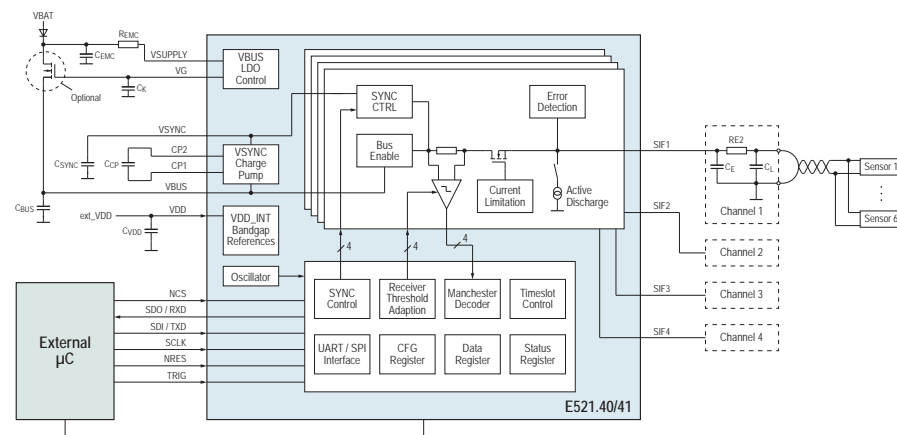

2-/4-Channel Sensor Interface PSI5 | E981.07/08

Key Features

- Two respective, four independent operating channels
- Device parameters comply with PSI5-P10P-500/3L (PSI5 spec 1.3)
- Applicable for parallel and universal mode (standard) as well as daisy chain mode (increased)
- Channel output short circuit protected against 40V and GND

Board

- Order No. see page 88



Applications

- Passenger restraint systems

Packages

- QFN32L7
- QFN20L5 respective

Application Diagram

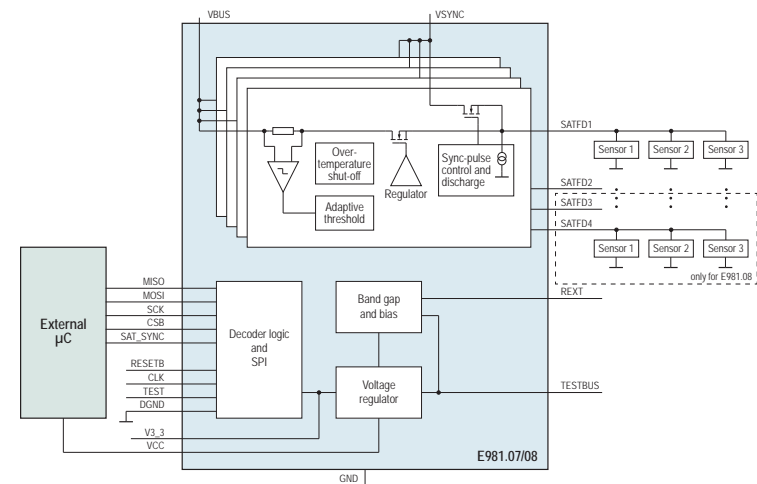

4-/8-Channel Airbag Squib Driver | E981.17/18

Key Features

- Two squib current modes (LCM and HCM) selectable via SPI commands
- Simultaneously firing of 4 loops possible
- Squib channel diagnostics and monitoring
- Autarky voltage & squib supply voltage diagnostics
- Separate low side and high side driver control
- Serial interface (SPI synchronous communication) to μC (3.3V and 5V tolerant inputs)



Applications

- Squib driver in a restraint diagnostic and control module (RDM)

Packages

- QFN44L7

Application Diagram

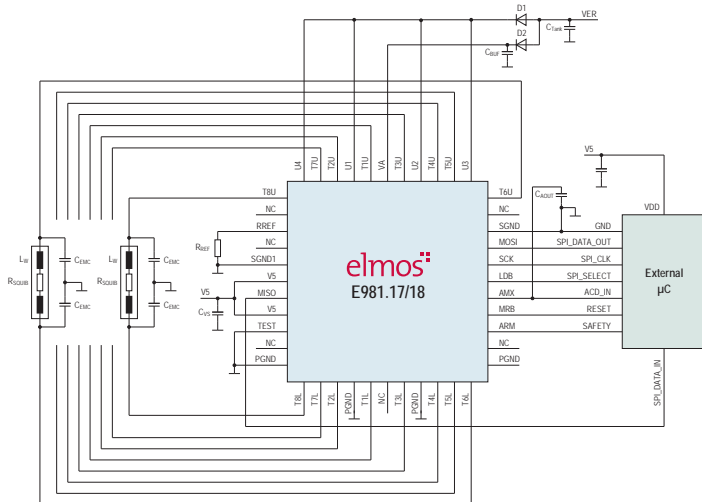

4-/8-Channel Squib Driver with Current Counter | E981.20/21

Key Features

- Two squib current modes (LCM and HCM) selectable via SPI commands
- Simultaneously firing of 4 loops possible
- Squib channel diagnostics, monitoring and current counter
- Autarky voltage & squib supply voltage diagnostics
- Separate low side and high side driver control
- Serial interface (SPI synchronous communication) to μC (3.3V and 5V tolerant inputs)



Applications

- Squib driver in a restraint diagnostic and control module (RDM)

Packages

- QFN44L7

Application Diagram

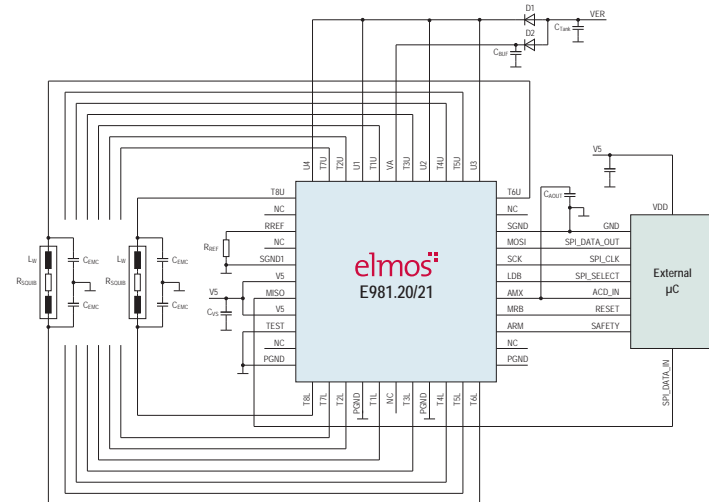

Passenger Safety Solutions



Special Projects - Engine Management

Part No. / Function	V_{SUPPLY}	RDS_{ON}	Interface	Package	Comment
E525.07 Glow Plug Control IC	5.5V to 16V (45V)	4x Gate driver	PWM, SPI	QFN32L6	<ul style="list-style-type: none">▪ Slew rate controlled gate driver▪ Gate sequencing▪ Advanced diagnosis▪ Ground shift compensating

Glow Plug Control IC | E525.07

Key Features

- 4 gate drivers for external hi-side power-NMOS
- PWM controlled gate output with integrated charge pump
- Adjustable gate charge / discharge currents
- Gate sequencing for minimum current ripple
- MOS protection by gate-source voltage limitation
- Glow plug current sense with over-current shut-off
- Battery measurement, over-voltage and undervoltage, shut-down, charge pump monitoring



Applications

- Quick start Diesel engine controls for Euro 6
- Ceramic glow plugs
- Steel glow plugs
- For direct and indirect injection

Packages

- QFN32L6

Application Diagram

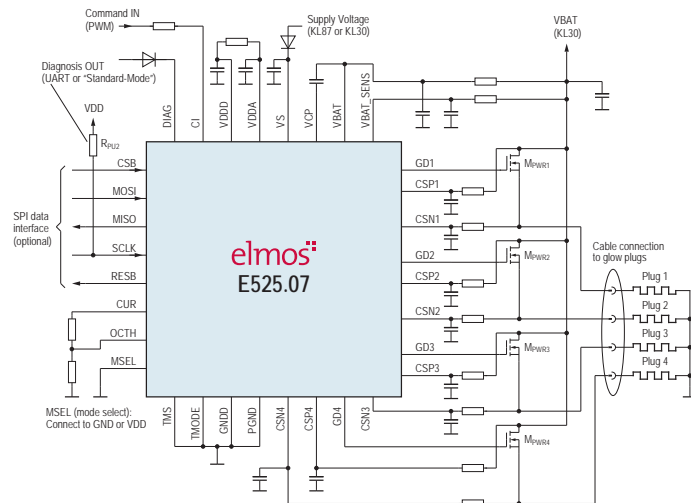

Special Projects - Relay Driver

Part No. / Function	High-Side Driven	Low-Side Driven	Bi-Stabil	Included μ C	Interface	Feed-Back Inputs	Package	Comment
E520.02/08 *Driver IC 12/8x Low-Side Relay driver with constant holding current	-	12/08	-	External	▪ SPI	0 (to ext. μ C)	QFN32L5 QFN20L5 SOIC20 SOIC28	▪ Automatical VBAT dependent PWM generation for constant holding current
E523.03/04 *SBC E523.13/14 LIN2.x Relay Node SBC for 1 Relay	1 or	1	-	External 3.3V/5V	▪ LIN1.3/2.x/PWM	0 (to ext. μ C)	QFN20L4 QFN32L5	▪ Regulator ▪ Watchdog
E523.01/11 *SBC LIN2.x Relay Node SBC for 6/5 Relays	6 or	6 or	5	External 3.3V/5V	▪ LIN1.3/2.x/PWM	0 (to ext. μ C)	QFN44L7 Q5OP44 QFN48L7	▪ Regulator ▪ Watchdog
E523.02/12 *SBC LIN2.x Relay Node SBC for 4/3 Relays	4 or	4 or	3	External 3.3V/5V	▪ LIN1.3/2.x/PWM	0 (to ext. μ C)	QFN44L7 Q5OP44	▪ Regulator ▪ Watchdog
E523.06 *SoC Free Programmable LIN2.x Relay Node for 6/5 Relays	6 or	6 or	5	16 bit 4-48Mhz	▪ LIN1.3/2.x/PWM ▪ Flashable via LIN	8	QFN48L7	▪ 32k Flash (free programmable) ▪ 16k SysROM (hardware LIN library) ▪ 4k RAM
E523.30/34 *SoC E523.31/37 Free Programmable LIN2.x Relay Node for 2-4 Relays	2 or	2 or	3	8 bit	▪ LIN1.3/2.x/PWM ▪ LIN auto-addressing ▪ Flashable via LIN	3	QFN32L6	▪ 8k Flash and ROM + 4k SysROM library ▪ switchable 5V supply for external needs ▪ 3.3V ADC reference for ratiometric measurements ▪ ROM version available

*Plug & Play Chip with defined functionality | no controller programming necessary
 *SoC System-on-a-Chip | with integrated microcontroller
 *SBC System-Basic-Chip | with Voltage Regulator Reset, Watchdog, physical Interface
 *Driver IC Driver Chip without SBC or SoC features

12/8x Low-Side Relay Driver with Constant Holding Current | E520.02/08

Key Features

- 12 high current outputs ($R_{DS(on)}$ typ. 1.5Ω / $I_{MAX} = 350mA$)
- Low standby current (typically $<1\mu A$)
- Serial interface (SPI) for direct μC interfacing
- Short circuit / Open load detection, diagnosis
- $T_{Junc peak} = +150^\circ C$



Applications

- Relay Driver with automatically V_{BAT} -dependent PWM duty cycle generation
- Low power dissipating relay boards

Packages

- QFN32L5
- QFN20L5
- SOIC20
- SOIC28

Application Diagram

*Driver IC

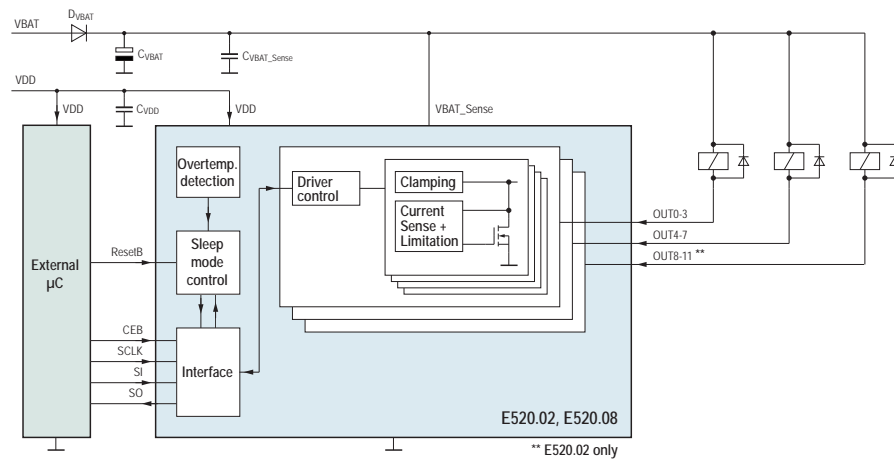

LIN2.x Relay Node SBC for 1 Relay | E523.03/04/13/14

Key Features

- Voltage range 7V to 28V (5V to 42V peak)
- Controlling 1 low side driven relay or 1 high side driven relay
- Relay pull-in and holding current can be controlled via PWM input
- Power supply 3.3V or 5V for external controller
- LIN2.x(1.3), SAE-J2602 interface or bidirectional PWM
- Several Diagnostic and protection functions
- Adjustable window watchdog
- $T_{Junc peak} = +170^\circ C$



Applications

- LIN2.x or LIN1.3 relay nodes

Packages

- QFN20L4
- QFN32L5 (with high voltage spacer)

Application Diagram

*SBC

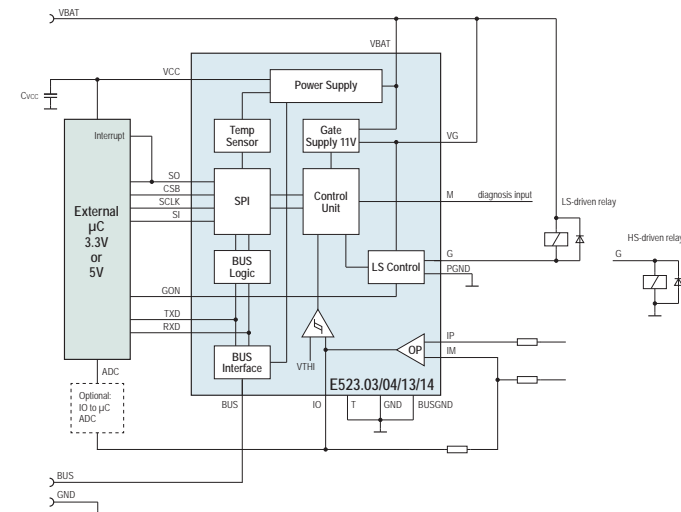

LIN2.x Relay Node SBC for 6/5 relays | E523.01/11

Key Features

- Voltage range 7V to 28V (5V to 42V peak)
- Controls 6 relays, low- or high-side driven or 5 bistable relays
- Relay pull-in and holding current can be controlled via PWM input
- Power supply 3.3V or 5V for external controller
- LIN 2.x interface (1.3), SAE-J2602 or PWM bidirectional
- Several diagnostic and protection functions
- Adjustable window watchdog
- T_{junc} peak = +170°C



Applications

- LIN2.x or LIN1.3 relay nodes

Packages

- QFN44L7
- QSOP44
- QFN48L7

Application Diagram

*SBC

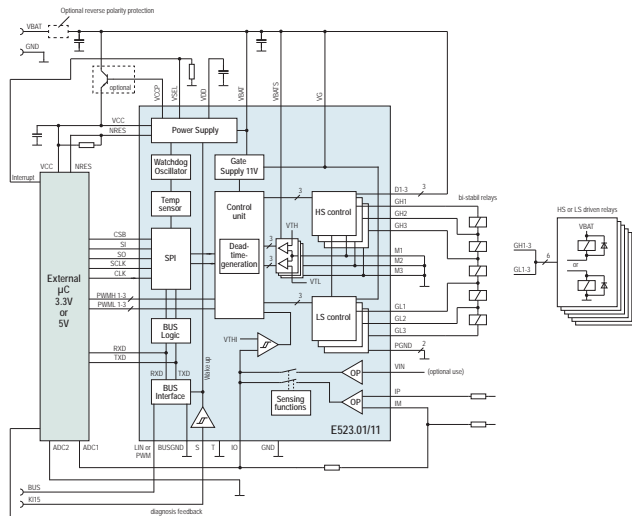

LIN2.x Relay Node SBC for 4/3 Relays | E523.02/12

Key Features

- Voltage range 7V to 28V (5V to 42V peak)
- Controls 4 relays, low- or high-side driven or 3 bistable relays
- Relay pull-in and holding current can be controlled via PWM input
- Power supply 3.3V or 5V for external controller
- LIN 2.x interface (1.3), SAE-J2602 or PWM bidirectional
- Several diagnostic and protection functions
- Adjustable window watchdog
- T_{junc} peak = +170°C



Applications

- LIN2.x or LIN1.3 relay nodes

Packages

- QFN44L7
- QSOP44

Application Diagram

*SBC

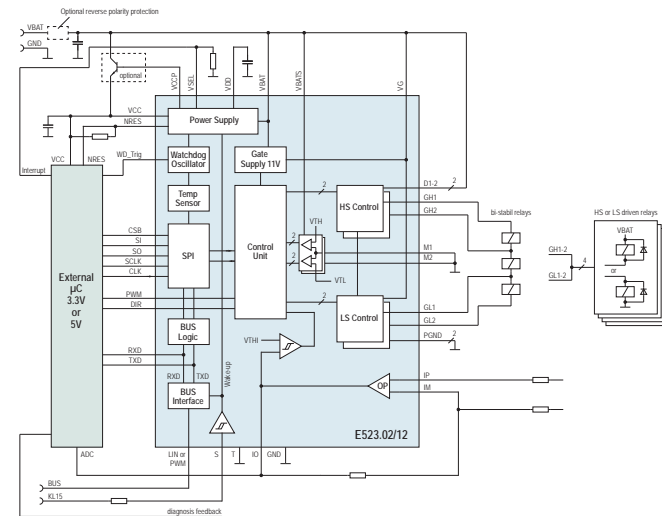

Free Programmable LIN2.x Relay Node for 6/5 relays | E523.06

Key Features

- Voltage range 7V to 28V (5V to 42V peak)
- Controls 6 relays high- or low-side driven or 5 bistable relays
- Relay pull-in and holding current can be controlled via PWM input
- LIN2.x(1.3)(SAE-J2602) interface or bidirectional PWM interface
- 16 bit RISC CPU 32k Flash 16k SysROM 4k SRAM
- 10 bit 1 Msample SAR ADC
- 4x 16 bit PWM generation (edge/center aligned)
- $T_{junc \text{ peak}} = +150^{\circ}\text{C}$



Applications

- LIN2.x or LIN1.3 relay nodes

Packages

- QFN48L7

Application Diagram

*SoC

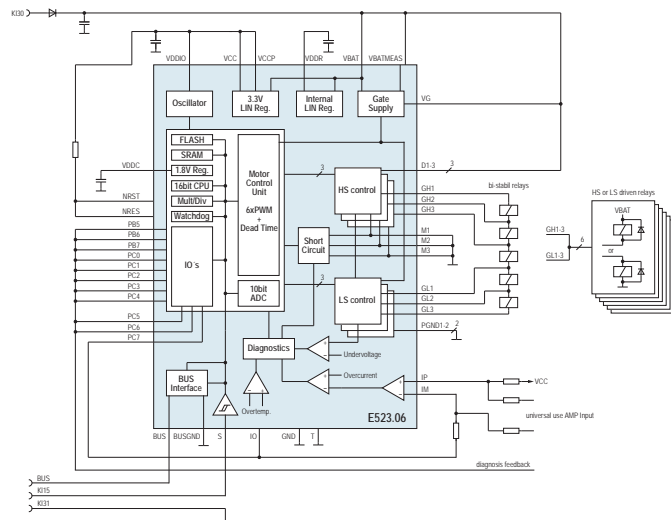

Free Programmable LIN2.x Relay Node for 2-4 relays | E523.30/31/34/37

Key Features

- Controls 4 high side driven relays or 2 low side driven relays or 3 bistable relays
- Programmable holding current for low-side up to 800mA
- 5.5V to 20V supply voltage (load dump 42V)
- Embedded 8bit μC 256 Byte RAM, 8k Flash + 4k SysROM, 64 Byte E²
- LIN2.x(1.3), SAE-J2602 or PWM Interface, LIN Auto-Addressing
- $T_{junc \text{ peak}} = +170^{\circ}\text{C}$



Applications

- LIN2.x or LIN1.3 relay nodes

Packages

- QFN32L6

Application Diagram

*SBC

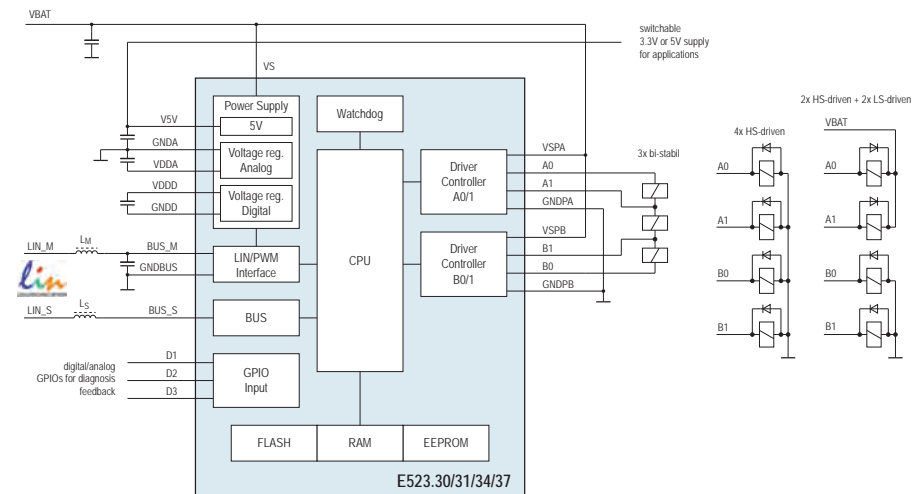

Special Projects - Boards

Safety

Part No.	Function	Board type	Order No.
E521.41	4-Channel Multi-Mode PSIS Transceiver	Demoboard	K52141-0001
E981.07	2-Channel Sensor Interface PSIS	Evaluation Board	K98107-0001
E981.07	2-Channel Sensor Interface PSIS	Adapter Board	K98107-0002

Pedestrian Safety Solutions



Distribution Service

Europe

Rutronik Elektronische Bauelemente GmbH

Industriestraße 2
75228 Ispringen (Germany)
Phone: +49 (0) 7231 / 801-0
Fax: +49 (0) 7231 / 822-82
rutronik@rutronik.com
www.rutronik.com

SILICA (An Avnet Company)

Gruber Strasse 60c
85586 Poing (Germany)
Phone: +49 (0) 8121 / 777 02
Fax: +49 (0) 8121 / 777 531
marketing@silica.com
www.avnet-silica.com

USA

Avnet Inc.

2211 South 47th Street
Phoenix, AZ 85034 (USA)
Phone: +1 480 / 643-2000
Fax: +1 214 / 342-7430
brian.lafragola@avnet.com
www.avnet.com

China

Mostyle Corporation

Rm 13A, 13th Floor, Orient Century Building
No. 345, XianXia Rd., Shanghai, 200336
(China)
Phone: +86 (0) 21 / 62 59 06 06
Fax: +86 (0) 21 / 62 74 63 52
gentle@mostyle.com.cn
www.mostyle.com.tw

Shanghai Chengsheng Industrial Co., Ltd.

Rm.2003, Wei Bai Xin Plaza
No. 1688 Kong Jiang Road
200092 Shanghai
Phone: +86 (0) 21 / 65036621
Fax: +86 (0) 21 / 55964388
liu.yuan@shcssy.com
www.shcssy.com

Suzhou FRED Opto-Electronics Co., Ltd.

1-207 room, No. 69,
Weixin Road, SIP Suzhou,
215122, China
Phone: +86 (0512) 06285 5581
service@fredsz.com

Teampo Technology Co., Ltd.

ADD:Rm 1206, HeCheng Centuty Famous
Manor, No. 118
Wuhe Avenue, BanTian, LongGang District,
ShenZhen, China
Phone: +86 (0) 755 / 83187999-8008
Fax: +86 (0) 755 / 82660789
alan_yan@teampo.com
www.teampo.com

ZLG-MCU Development Co., Ltd. (Greater China - Mainland, Taiwan, Hong Kong)

Room F4,12/F Everbright Bank Mansion
No. 689 Tianhe Road North
510630 Guangzhou (China)
Phone: +86 (0) 20 / 8556 1347
Fax: +86 (0) 20 / 3873 0925
elmos.order@zlgmcu.com
www.zlgmcu.com

India

Millennium Semiconductors

17/18/19, 2nd Floor, Mahalaxmi Heights,
Mumbai-Pune Road, Pimpri,
Pune 411 018, Maharashtra, India
Phone: +91 20 27484800
Fax: +91 20 27484900
info@millenniumsemi.com
www.millenniumsemi.com

Swingtel Communications

Pvt Ltd. 15-16, Mistry Bldg, 3rd Floor,
635-637 J S S Road, Off Marine Lines,
Mumbai- 400 002, India
Phone: +91-22-2200 0123
Fax: +91-22-2200 0222
info@swingtel.com
www.swingtel.com

Japan

Tokai Electronics Co., Ltd.

3-34-14 , Sakae, Naka-ku,
Nagoya, Aichi 460-8432 (Japan)
Phone: +81 52-261-3213
Fax: +81 52-261-7855
info@tokai-ele.co.jp
www.tokai-ele.co.jp

Restar Electronics Corporation

2-32-3, Kita-Shinagawa
Shinagawa-ku,
Tokyo 140-0001 (Japan)
Phone: +81 3-5781-1012
Fax: +81 3-5781-1017
info-semicon@restargp.com
www.restargp.com

Singapore

Le Champ (South East Asia) Pte. Ltd.

No. 3 Jalan Mesin,
Le Champ Building,
Singapore 368810
Phone: +(65) 6272 8877
Fax: +(65) 6274 2020
erwin.olviga@lechamp.com.sg
www.lechamp.com.sg

Korea

ALWOX Co.,Ltd.

D-412, IT Valley,
40, Imi-ro, Uiwang-si,
Gyeonggi-do, Korea
ZIP: 16006
Phone: +82 (70) 4046 / 5524
Fax: +82 (50) 5300 / 5524
admin@alwox.com

DABO Corporation

Room 909, DaeRyung Technotown 3rd,
115, Gasan Digital 2-ro, Gumcheon-gu,
Seoul, Korea
ZIP: 08505
Phone: +82 (2) 2615-9999
Fax: +82 (2) 2108-5555
yw.kwon@dabo-corp.com
www.dabo-corp.com

Taiwan

Mostyle Corporation

3F, No. 50
Chow Tze Street
Nei-Hu, Taipei 114 (Taiwan)
Phone: +886 (0) 2 / 87 97 28 00
Fax: +886 (0) 2 / 87 97 28 02
sales_elmos@mostyle.com.tw
www.mostyle.com.tw

Zenitron Corporation

No.8, Lane 250, Sinhu 2nd Rd.,
Neihu District, Taipei City, 114
Taiwan, R.O.C.
Phone: +886 (0) 2 / 2792-8788
Fax: +886 (0) 2 / 2792-8859
brian_chen@zenitron.com.tw
www.zenitron.com.tw

Elmos Sales and Application Support

Headquarters

Elmos Semiconductor SE
Heinrich-Hertz-Str. 1
44227 Dortmund (Germany)
Phone: +49 (0) 231 / 75 49-100
Fax: +49 (0) 231 / 75 49-149
sales-germany@elmos.com
www.elmos.com

Office North America

Elmos N.A. Inc.
47023 Five Mile Road
Plymouth, MI 48170 (United States)
Phone: +1 (0) 248 / 8 65 32 00
Fax: +1 (0) 248 / 8 65 32 03
sales-usa@elmos.com

Office China

Elmos Semiconductor Technology
(Shanghai) Co., Ltd.
Unit 16B, 16F Zhao Feng World Trade
Building, No. 369 Jiang Su Road,
Chang Ning District, Shanghai,
P.R. China, 200050
Phone: +86 (0) 21 / 6219 7502
Fax: +86 (0) 21 / 6210 0908 115
sales-china@elmos.com

Office Korea

Elmos Korea Co., Ltd.
Office: C-301, Innovalley, 253, Pangyo-ro,
Bundang-gu, Sungnam-si, Gyeonggi-do,
13486 Korea
Phone: +82 (0) 31 714-1131
Fax: +82 (0) 31 8018-0790
sales-korea@elmos.com

Office Japan

Elmos Japan K.K.
Tamachi 16th Fujishima Bldg. 6F
4-13-4 Shiba, Minato-ku,
Tokyo, 108-0014, Japan
Phone: +81 3 / 3451-7101
Fax: +81 3 / 3451-7104
sales-japan@elmos.com

Office Singapore

Elmos Semiconductor Singapore Pte Ltd.
29 International Business Park
#05-03 ACER, 609923 Singapore
Phone: +65 (0) 6908 / 1261
Fax: +65 (0) 6570 / 5906
sales-singapore@elmos.com

Your local partner