

ELKAY® *With FLEXI-GUARD*®

INSTALLATION & USE MANUAL

EZ™ & LZ™ Series Bottle Filling Stations & Coolers



Patent zurn-elkay.com/patents

⚠ **WARNING:** Cancer and Reproductive Harm - www.P65Warnings.ca.gov

⚠ **ADVERTENCIA:** Cáncer y daño reproductivo - www.P65Warnings.ca.gov

⚠ **AVERTISSEMENT:** Cancer et effets néfastes sur la reproduction - www.P65Warnings.ca.gov

Note: Danger! Electric shock hazard. Disconnect power before servicing unit.

Pictured is unit only without bottle filler.

Uses HFC-134A refrigerant

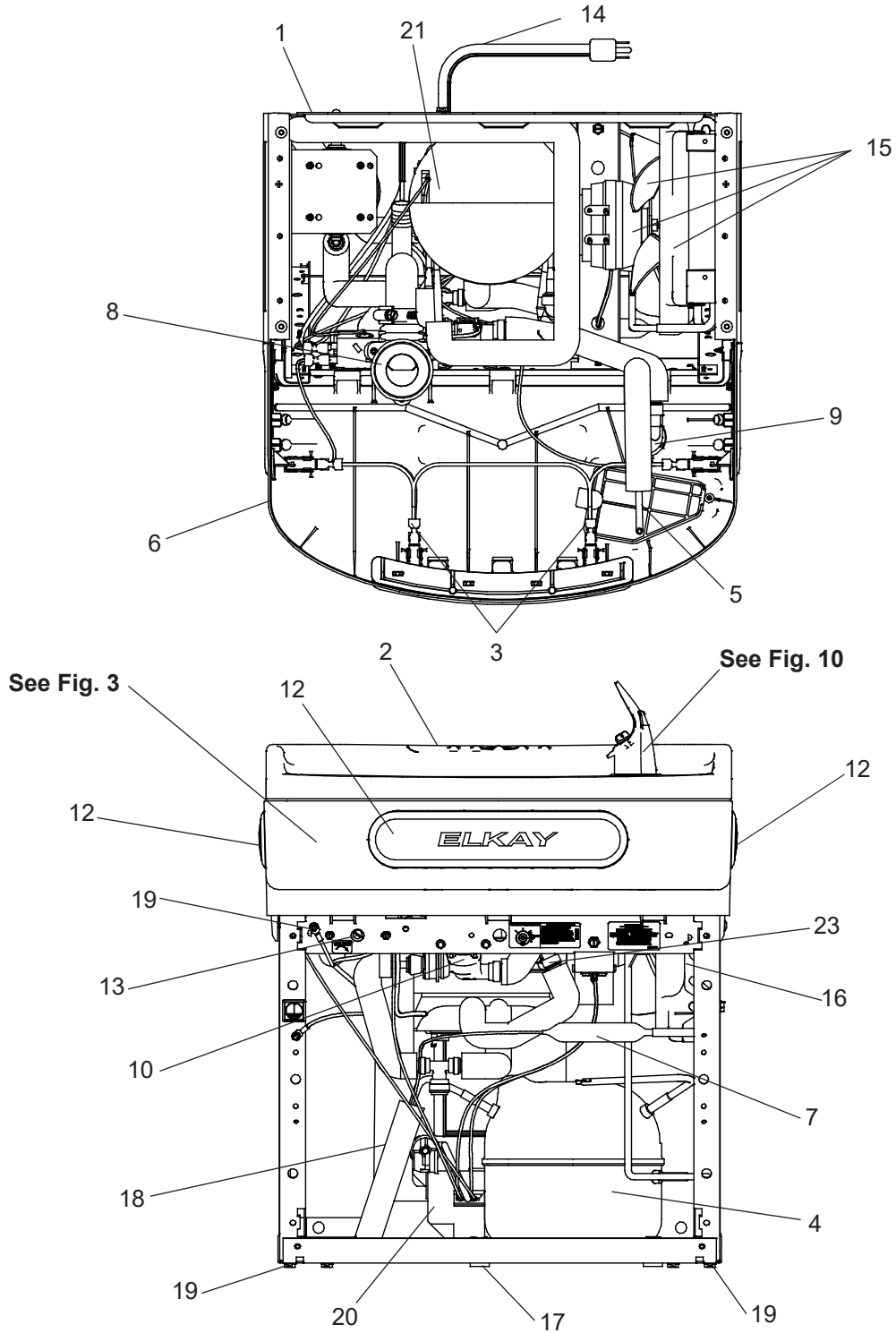

Fig. 1

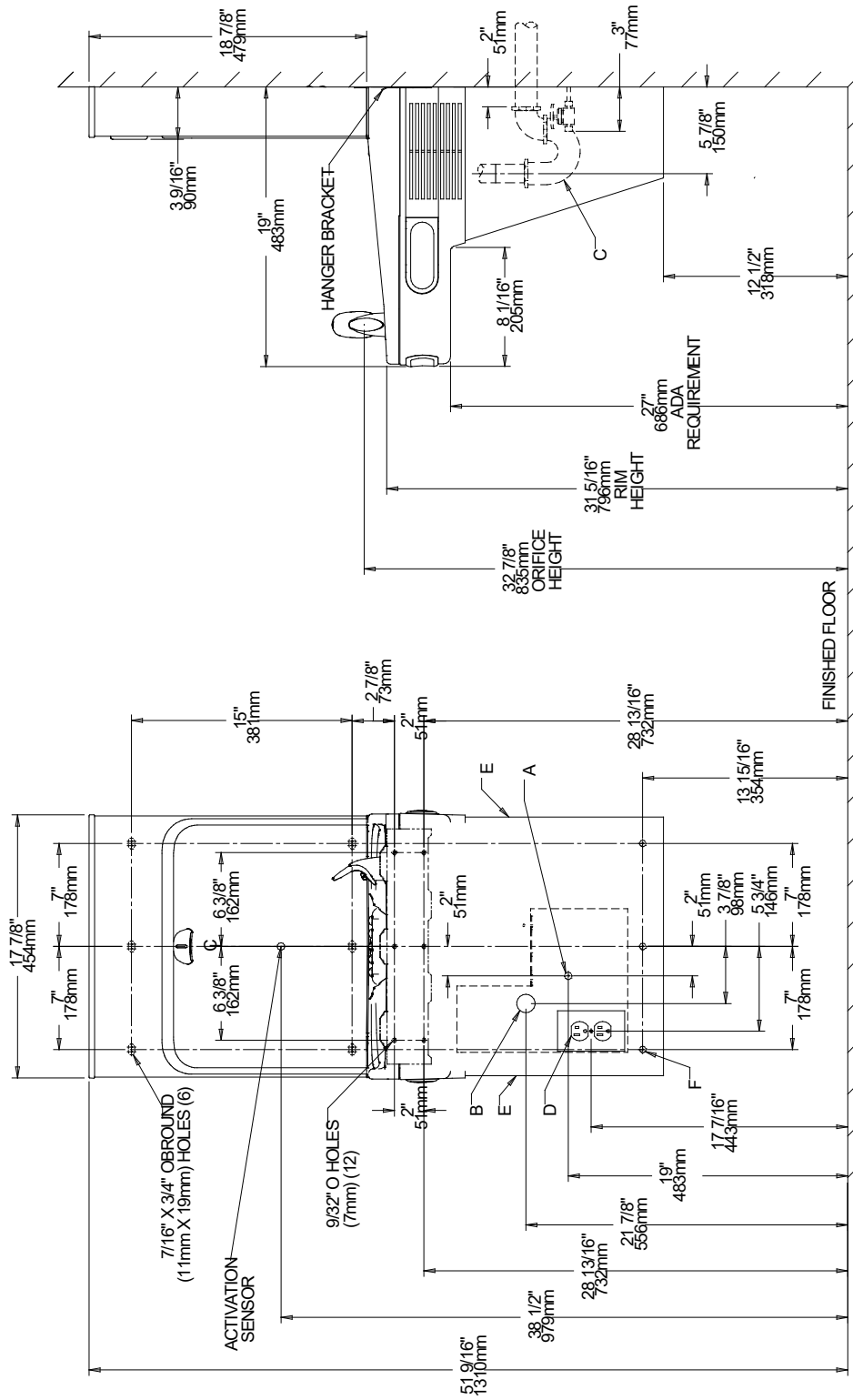

Fig. 2

*ADA REQUIREMENT

REDUCE HEIGHT BY 3 INCHES FOR INSTALLATION OF CHILDREN'S ADA COOLER

- LEGEND:
- A = RECOMMENDED WATER SUPPLY LOCATION 3/8 O.D. UNPLATED COPPER TUBE CONNECT STUB WITH SHUT OFF (BY OTHERS) 3 IN. (6mm) MAXIMUM OUT FROM WALL
 - B = RECOMMENDED LOCATION FOR WASTE OUTLET 1-1/4" O.D. DRAIN STUB 2 IN. OUT FROM WALL
 - C = RECOMMENDED LOCATION FOR WASTE OUTLET 1-1/4" O.D. DRAIN STUB 2 IN. OUT FROM WALL
 - D = ELECTRICAL SUPPLY (3) WIRE RECESSED BOX DUPLEX OUTLET**
 - E = ELECTRICAL SUPPLY (3) WIRE RECESSED BOX DUPLEX OUTLET**
 - F = 7/16 BOLT HOLES FOR FASTENING UNIT TO WALL
- **NEW INSTALLATIONS MUST USE GROUND FAULT CIRCUIT INTERRUPTER (GFCI)

**HANGER BRACKETS & TRAP
INSTALLATION**

- 1) Remove hanger bracket fastened to back of cooler by removing one (1) screw.
- 2) Mount the hanger bracket as shown in Figure 2.

NOTE: Hanger Bracket **MUST** be supported securely. Add fixture support carrier if wall will not provide adequate support. Anchor hanger securely to wall using all six (6) 1/4 in. dia. mounting holes.

IMPORTANT:

5-7/8 in. (150mm) dimension from wall to centerline of trap must be maintained for proper fit.

INSTALLATION OF COOLER

- 3) Hang the cooler on the hanger bracket. Be certain the hanger bracket is engaged properly in the slots on the cooler back as shown in Figure 2.
- 4) Remove the four (4) screws holding the lower front panel at the bottom of cooler. Remove the front panel by pulling straight down and set aside.
- 5) Connect water inlet line--See Note 4 above.
- 6) Install trap. Remove the slip nut and gasket from the trap and install them on the cooler waste line making sure that the end of the waste line fits into the trap. Assemble the slip nut and gasket to the trap and tighten securely.

IMPORTANT: If it is necessary to cut the drain, loosen the screw at the black rubber boot and remove tube, check for leaks after re-assembly.

- 7) Plug in electrical power. Unit must have electrical power to have water flow.

START UP

Also See General Instructions

- 8) Stream height is factory set for 35 PSI supply. If supply pressure varies greatly from this, adjust screw located on the right knee clearance area. CW adjustment will raise stream and CCW adjustment will lower stream. For best adjustment, stream should hit basin approximately 6-1/2" (165mm) from bubbler on the downward slope of the basin.

NOTE: If continuous flow occurs at the end of the compressor cycle, turn cold control counterclockwise 1/4 turn.

- 9) Replace the front panel ensuring that the metal wrapper is secured inside of the upper shroud. Replace all four screws previously removed.

CLEANING

Warm, soapy water or mild household cleaning products can be used to clean the exterior panels of the EZ coolers. Extra caution should be used to clean the mirror finished stainless steel panels. They can be easily scratched and should only be cleaned with mild soap and water or Windex glass cleaner and a clean, soft cloth. Use of harsh chemicals or petroleum based or abrasive cleaners **will void the warranty**.

Service Instructions

Lower and Upper Shroud

To access the refrigeration system and plumbing connections, remove four screws from bottom of cooler to remove the lower shroud. To remove the upper shroud for access to the pushbars, regulator, solenoid valve or other components located in the top of the unit, remove lower shroud, disconnect drain, remove four screws from tabs along lower edge of upper shroud, unplug two wires and water tube.

Bubbler

To remove the bubbler, first disconnect the power supply. The underside of the bubbler can be reached through the access panel on the underside of the upper shroud. Remove the access panel by removing the retaining screw. To remove the bubbler, loosen locknut from the underside of the bubbler and remove the tubing from the quick connect fitting per the Operation Of Quick Connect Fittings section in the General Instructions. After servicing, replace the access panel and retaining screw.

Switches Behind the Push Bar

The regulator in an EZ cooler is always held fully open by the use of a single regulator nut. Water is not dispensed until the pushbar is depressed to activate a switch which then opens a solenoid valve. When installing the regulator nut, the regulator spring must be depressed while turning the nut.

To remove sidebars, from the inside compress the flared tabs and pull out carefully. To reinstall side pushbars, the front of the pushbar is inserted first. While keeping the switch depressed, snap the rear of the pushbar into position.

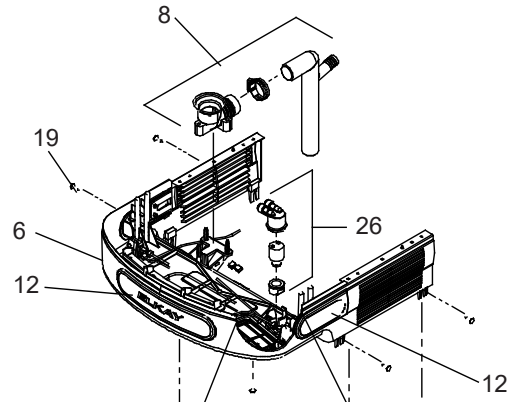
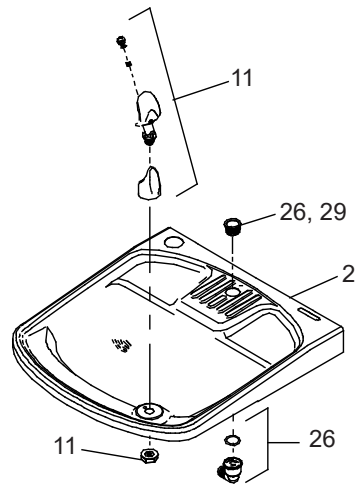

REGULATOR ASSEMBLY

ALIGNMENT NOTCH

SNAP

SNAP

ALIGNMENT PEG

Fig. 3

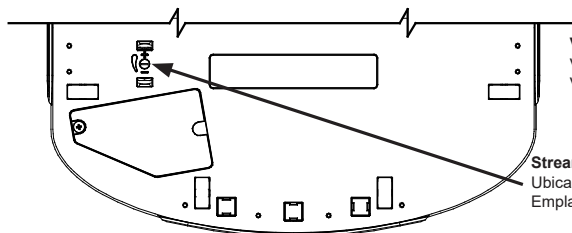

View of Underside of Basin Shroud
Vista de la parte inferior de la cuenca cubierta
Vue de dessous du bassin du Saint-Suaire

Stream Height Adjustment Location
Ubicación de ajuste de altura de corriente
Emplacement de réglage hauteur Stream

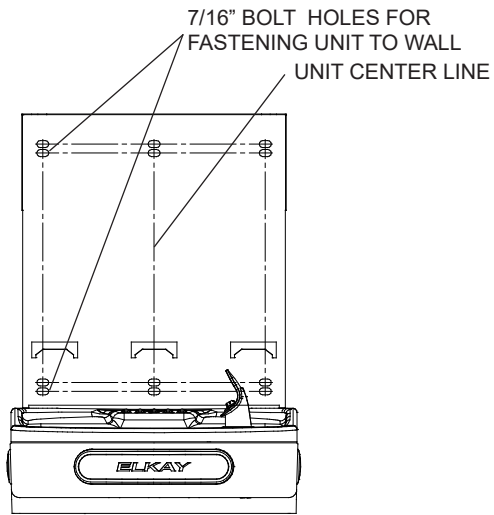

Fig. 4

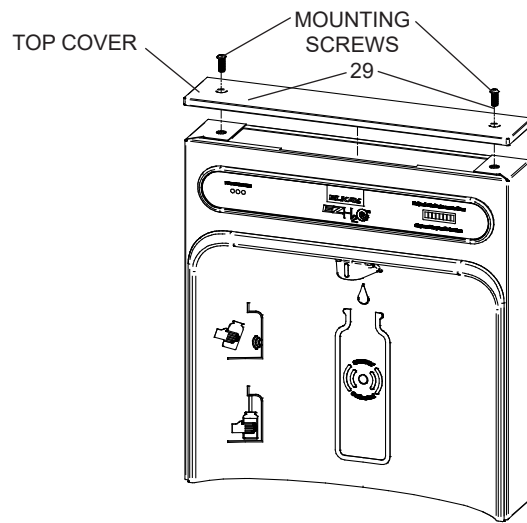

Fig. 5

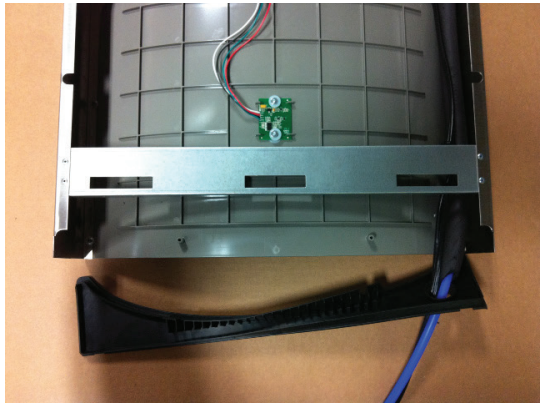

Fig. 6



Fig. 7

BRACKET & SCREWS

Bottle Filler Installation Instructions

- 1) **Remove two (2) mounting screws** with 5/32" Allen wrench holding top cover to Bottle Filler (See Fig. 5). Remove top cover. Note do not discard mounting screws, they will be needed to **reinstall top cover**.
- 2) **Remove wall mounting plate** from Bottle Filler. Place wall plate against wall on top of basin. Center the wall plate side to side with the basin. Mark the six (6) mounting holes with a pencil (See Fig. 4).
- 3) **Remove wall mounting plate** from wall. **NOTE:** Mounting plate **MUST** be supported securely. Add fixture support carrier if wall will not provide adequate support.
- 4) **Install wall mounting plate** to wall using six (6) 7/16" obround mounting holes (mounting bolts not included) (See Fig. 4). Use appropriate fasteners for your wall type.
- 5) **Feed power cord & 3/8" water line** through hole in tower/basin gasket (See Fig 6).
- 6) **Install gasket** on bottom of bottle filler tower with gasket support bracket & (2) screws (See Fig 7).
- 7) **Lay Bottle Filler on water cooler basin** and cut insulation from tube even with bottom of gasket, remove this insulation from the 3/8" tube, but do not discard. **Feed the power cord** and waterline through the hole on top of water cooler. **NOTE:** To prevent scratching the basin place a towel or soft cloth over the entire basin when working above it.
- 8) **With the power cord** and waterline through hole on top of water cooler place Bottle Filler on the three (3) angled tabs protruding from the wall mounting plate installed on wall. Make sure round boss in gasket fits in hole of basin. (See Fig. 8).
- 9) **Once Bottle Filler** is installed on wall plate tabs, water line and power cord are installed properly, push top of Bottle Filler toward wall and line up top cover two (2) holes.
- 10) **Reinstall Top Cover** on Bottle Filler (See Fig. 5) with two mounting screws from step 1 above. Caution, do not over tighten screws.
- 11) **Install remaining tube insulation** to the water line from bottle filler, connect Bottle Filler waterline inside of the water cooler by connecting the 3/8" water line to the tee.
- 12) **Install filter cartridge**, remove filter from carton, remove protective cap, attach filter to filter head by firmly inserting into head and rotating filter clockwise. **NOTE:** If existing plumbing rough in locations (Drain, Water In, and Electric Supply) do not allow the filter to be mounted inside the cooler cabinet the filter can be installed horizontally below the unit. A retrofit kit is available to mount the filter beneath the cooler.
- 13) **Turn water supply on** and inspect for leaks. Fix all leaks before continuing.
- 14) **Once unit has been inspected** for leaks and any leaks found corrected, plug Bottle Filler and unit into wall. Be sure to reinstall fuse to the circuit or switch the circuit breaker back to the "ON" position.
- 15) **Once power is applied to Bottle Filler**, the GREEN LED light should illuminate showing good filter status along with the LCD Bottle Counter.
- 16) **Verify proper dispensing** by placing cup, hand, or any opaque object in front of sensor area and verify water dispenses. Note: the first initial dispenses might have air in line which may cause a sputter. This will be eliminated once all air is purged from the line.
- 17) **Once unit tests out**, install Lower Panel back on water cooler. Unit is now ready for use.

BF11 - BF12 PROGRAM

SETTING THE CONTROL BOARD

VERIFY CONTROL BOARD SOFTWARE

- 1) To verify the software program of the control board the unit will need to be shut down and restarted. The chiller (if present) does not need to be shut down and restarted.
- 2) The units lower panel must be open to access the power cord and wall outlet.
- 3) Shut down the unit by unplugging the power cord from the wall outlet.
- 4) Restart the unit by plugging the power cord back into the wall outlet.
- 5) Upon start up, the bottle count display will show the software designation of BF11 or BF12.

ACCESSING THE PROGRAMMING BUTTON

- 1) To access the program button, remove the top cover of the bottle-filler. Remove the two (2) screws holding top cover to bottle-filler with a 5/32" allen wrench. Remove top cover. Do not discard mounting screws, they will be needed to reinstall the top cover after programming operations are completed. The programming button is located at the top right side of the unit on the control board.

NOTE: When applicable, there is also an alternate reset button located on the lower part of the water cooler. After removing the bottom cover, the reset button will be located on the left side of the cooler, mounted on the side panel support.

RESET THE FILTER MONITOR

- 1) Instructions apply to filtered units only.
- 2) Depress the program button for approximately 2 seconds until the display changes then release. The display will change and scroll through two messages:
"RST FLTR" – Reset Filter Monitor
"SETTINGS" – System Settings Sub Menu
If the program button is not pushed again the display will scroll through the two messages above for three cycles and then default back to bottle count and be back in run mode.
- 3) When the display changes to "RST FLTR", depress the button again. The display will change to show "FLTR =". Depress the button again and the display will show "FLTR =0"
- 4) The Green LED should be illuminated indicating that the visual filter monitor has been reset.

SETTING RANGE OF THE IR SENSOR WHERE APPLICABLE

- 1) Depress the program button for approximately 2 seconds until the display changes then release. The display will change and scroll through two messages:
"RST FLTR" – Reset Filter Status LED
"SETTINGS" – System Settings Sub Menu
If the program button is not pushed again the display will scroll through the two messages above for three cycles and then default back to bottle count and be back in run mode.
- 2) When the display changes to "SETTINGS", depress the button again. The display will change to show
"RNG SET" - Range set for IR sensor.
"UNIT TYP" - Type of unit (REFRIG or NON-RFRG)
"FLT SIZE" - Select filter capacity
"RST BCNT" - Reset bottle count
- 3) When display shows "RNG SET" push program button once the display will show current value (can be 1 – 10) e.g. "RNG = 3".
- 4) Once display shows current value push the program button to scroll through value of 1 – 10. Select the desired range setting, "1" being closest to sensor and "10" being farthest away.
- 5) Once range is selected allow approximately 4 seconds to pass and then the display will go back to bottle counter and be in run mode.
- 6) Test bottle filler by placing bottle or hand in front of sensor to make sure water is dispensed.

SETTING UNIT TYPE

- 1) Depress the program button for approximately 2 seconds until the display changes then release. The display will change and scroll through two messages:
"RST FLTR" – Reset Filter Status LED
"SETTINGS" – System Settings Sub Menu
If the program button is not pushed again the display will scroll through the two messages above for three cycles and then default back to bottle count and be back in run mode.

Continued from below:

- 2) When the display changes to "SETTINGS", depress the button again. The display will change to show
"RNG SET" - Range set for IR sensor.
"UNIT TYP" - Type of unit (REFRIG or NON-RFRG)
"FLT SIZE" - Select filter capacity
"RST BCNT" - Reset bottle count
- 3) When display shows "UNIT TYPE" push program button once the display will show current value. Can be REFRIG or NON-RFRG
- 4) Push button once to change value. Once value is selected the display will show the new value. (Can be REFRIG or NON-RFRG)
"REFRIG" - stands for refrigerated product. In this setting the flow rate is estimated at 1.0 gallon per minute.
"NON-RFRG" - stands for nonrefrigerated product. In this setting the flow rate is estimated at 1.5 gallons per minute. Both "REFRIG" and "NON-RFRG" simulate 1 bottle equal to 20 oz.
- 5) Allow approximately 4 seconds to pass and the display will return to bottle counter and be in run mode.

RESETTING BOTTLE COUNT

- 1) Depress the program button for approximately 2 seconds until the display changes then release. The display will change and scroll through two messages:
"RST FLTR" – Reset Filter Status LED
"SETTINGS" – System Settings Sub Menu
If the program button is not pushed again the display will scroll through the two messages above for three cycles and then default back to bottle count and be back in run mode.
- 2) When the display changes to "SETTINGS", depress the button again. The display will change to show:
"RNG SET"- Range set for IR sensor.
"UNIT TYP" - Type of unit (REFRIG or NON-RFRG)
"FLT SIZE" - Select filter capacity
"RST BCNT" - Reset bottle count
If the button is not pushed again the display will scroll through the four messages above for three cycles and return to run mode.
- 3) When display shows "RST BCNT" push program button once the display will show current value, e.g. "0033183".
- 4) Once display shows current value push the program button once more to reset back to 0. The display will show BTLCT = 0 for approximately 2 seconds and then return to run mode showing 00000000 bottles.
NOTE: Once the bottle count is reset to zero there is no way to return to the previous bottle count.
- 5) Testing the bottle counter:
REFRIG units: Place bottle or hand in front of sensor for approximately 9 seconds to see bottle counter count 00000001,
(This is based on filling a 20 oz. bottle).
NON-RFRG units: Place bottle or hand in front of sensor for approximately 6 seconds to see bottle counter count 00000001,
(This is based on filling a 20 oz bottle).

SETTING FILTER CAPACITY

- 1) Depress the program button for approximately 2 seconds until the display changes then release. The display will change and scroll through two messages:
"RST FLTR" – Reset Filter Status LED
"SETTINGS" – System Settings Sub Menu
If the program button is not pushed again the display will scroll through the two messages above for three cycles and then default back to bottle count and be back in run mode.
- 2) When the display changes to "SETTINGS", depress the button again. The display will change to show:
"RNG SET"- Range set for IR sensor.
"UNIT TYP" - Type of unit (REFRIG or NON-RFRG)
"FLT SIZE" - Select filter capacity
"RST BCNT" - Reset bottle count
If the button is not pushed again the display will scroll through the four messages above for three cycles and return to run mode.
- 3) When display shows "FLT SIZE" push program button once. The display will show current value. Can be 3000GAL or 6000GAL.
- 4) Push program button again to display the desired "FLT SIZE".
- 5) Allow approximately 4 seconds to pass and the display will return to bottle counter and be in run mode.

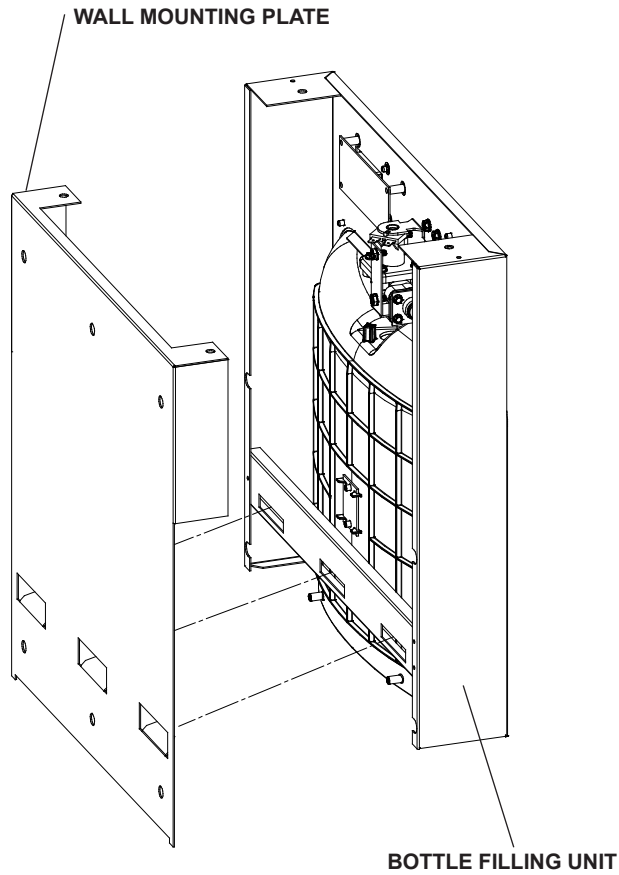

Fig. 8

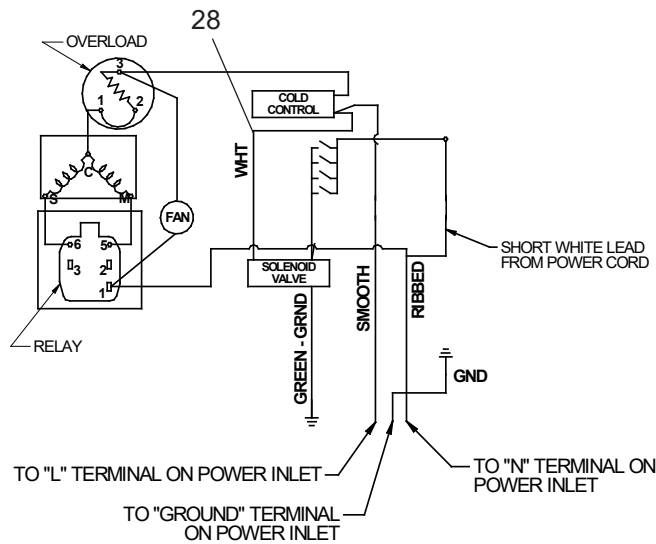

Fig. 9

220V-240V Refrigerated Wiring Diagram

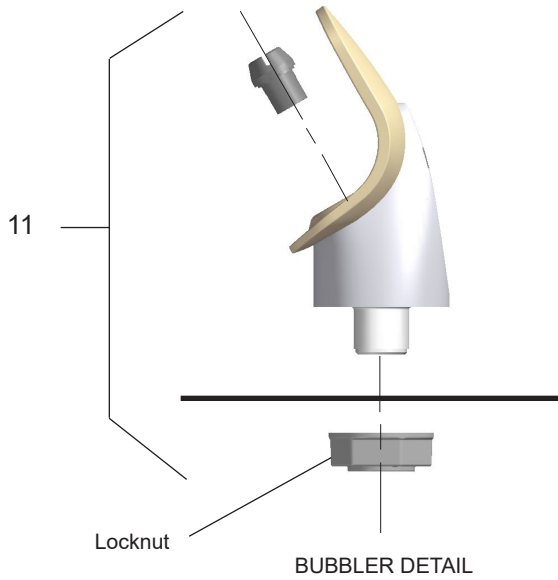

Fig. 10

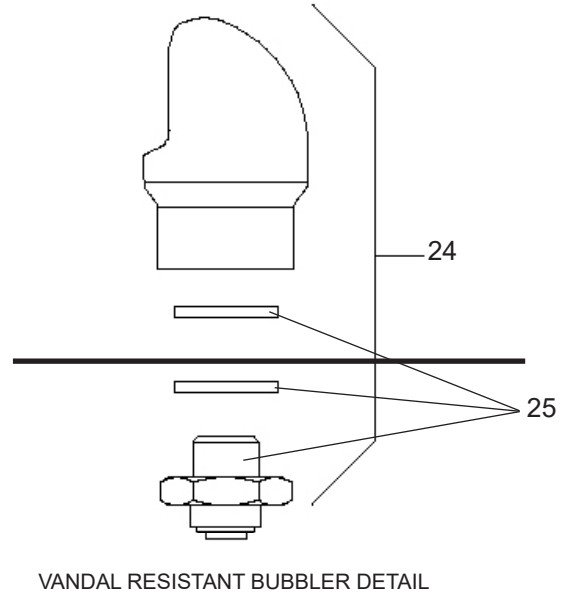

Fig. 11

NOTE:

When installing replacement bubbler and pedestal, tighten nut only to hold parts snug in position. Do Not Overtighten.

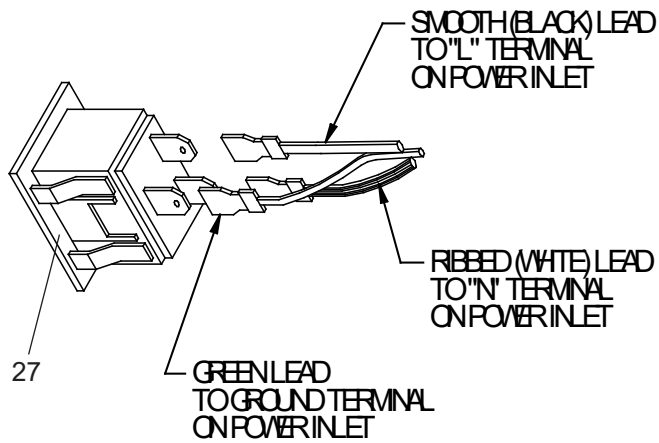
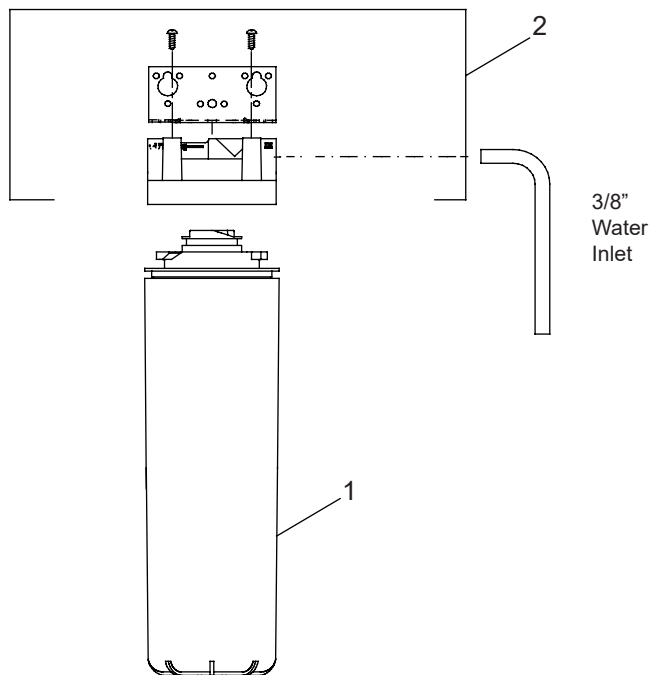

Fig. 12



Scan for trouble shooting and to sign up for auto replenishment of authentic Elkay filters.



Filter Detail

Fig. 13

FILTER PARTS LIST		
ITEM NO.	PART NO.	DESCRIPTION
1	51300C	Filter Assy-3000 Gal.
2	0000000746	Assy-Filter & Brkt includes Filtr Head/Mtg Bkt/ John Guest Figs/Screws

OPERATION OF QUICK CONNECT FITTINGS

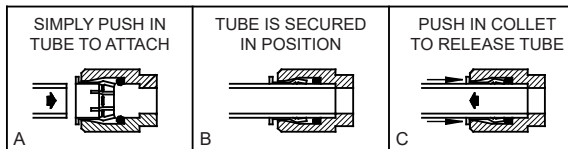

PUSHING TUBE IN BEFORE PULLING IT OUT HELPS TO RELEASE TUBE

Fig. 14

220V PARTS LIST

ITEM NO.	PART NO.	DESCRIPTION
1	28401C	Hanger Bracket
2	0000001337	Basin - Stainless Steel
3	36216C	Wiring - Front/Side Push Bar
*4	1000002194	Compr - Service Pak
5	56092C	Tube - Poly (Cut To Length)
6	56229C	Assy - Shroud - Upper (Front Side Push)
7	66703C	Drier
8	1000001877	Kit - Drain Replacement EZ (BF)(Brkt/Tube/Ftg/Clamp)
9	1000004564	Kit - Regulator w/Holder & Nut
10	1000004575	Kit - Solenoid Valve/Regulator Assy
11	56073C	Kit - Flexi Bubbler/O"-Ring/Nut
12	98734C	Kit - Pushbar (Front/Side) EZS TL
	1000001600	Kit - Pushbar (Front) EZS TL
13	98773C	Kit - Cold Control/Screws
14	36066C	Internal Pwr Cord
15	0000000245	Kit - Fan Motor Assy/Blade/Mtr/Shroud/Screws/Nut
16	98776C	Kit - Condenser/Drier
17	0000000256	Kit- Compr Mtg Hdwe/Grommets/Clips/Studs
18	98778C	Kit - Heatx/Drier
19	98898C	Kit - Hardware (EZ)
20	1000002195	Kit - Elect/Relay/Overload/Cover
21	98724C	Kit - Evaporator Assembly
22	0000001144	Tee - 1/4" x 1/4" x 3/8"
23	1000001602	Kit - 75583C Elbow 5/16" x 1/4"
24	97446C	Kit - VR Bubbler Short
25	1000001791	Kit - VR Bubbler Nipple W/Gasket
26	1000001812	Kit - Bottle Filler Drain (EZ)
27	35826C	Power Inlet
28	36004C	Jumper Wire (White)
29	0000001339	Ferrule-Drain (BF)
30	27416C	Wrapper - Stainless
NS	27413C	Wrapper - Light Grey
NS	See Filter Table	Water Filter Kit (When Provided)

NS = NOT SHOWN

***INCLUDES RELAY & OVERLOAD. IF UNDER WARRANTY, REPLACE WITH SAME COMPRESSOR USED IN ORIGINAL ASSEMBLY.**

NOTE: All correspondence pertaining to any of the above water coolers or orders for repair parts MUST include Model No. and Serial No. of cooler, name and part number of replacement part.

BOTTLE FILLER REPLACEMENT PART KITS

ITEM NO.	PART NO.	DESCRIPTION
NS	98631C	Kit - Electrical Package-220V
NS	98544C	Kit - IR Sensor
NS	1000004574	Kit - BF Solenoid Valve Replacement-220V
NS	98546C	Kit - Aerator Replacement
30	98547C	Kit - Top Cover Replacement
NS	98549C	Kit - Hardware & Waterway Parts
NS	98551C	Kit - Filter Mounting Cover
NS	98552C	Kit - Retro Filter Mounting
NS	1000001813	Kit - Tower/Basin Gasket

NS = NOT SHOWN