



TIMKEN



TIMKEN® SNT PLUMMER BLOCK CATALOG



TIMKEN® SNT PLUMMER BLOCK CATALOG INDEX

Timken Overview	2
Housed Unit Introduction	4
Shelf Life Policy	11
Engineering	17
Lubrication	37
SNT Plummer Block Nomenclature	50
SNT Plummer Block Introduction	51
Seals	53
SNT Plummer Block Installation Guides	55
SNT Plummer Block Product Data Tables	60
Spherical Roller Bearing Nomenclature	84
Spherical Roller Bearing Product Data Tables	85
SNT Spherical Roller Bearing Metric Accessories	93



GROW STRONGER WITH TIMKEN

Every day, people around the world count on the strength of Timken. Our expertise in metallurgy, friction management and mechanical power transmission helps them accelerate improvements in productivity and uptime.

We supply products and services that can help keep your operations moving forward, whether you need drivetrain kits for commercial vehicles, durable housings for bearings in dirty environments, couplings that avoid metal-to-metal contact between motors and gearboxes, repair services for rail bearings, steel for an aircraft engine shaft, or other products and services for your applications.

When you choose Timken, you receive more than high-quality products and services: you gain a worldwide team of highly trained and experienced Timken people committed to working collaboratively with you to improve your business.

Globally, our 20,000 people provide reliable answers for a wide range of operations in manufacturing, mining, medical equipment, aerospace, transportation, oil and gas – and other diverse industries.

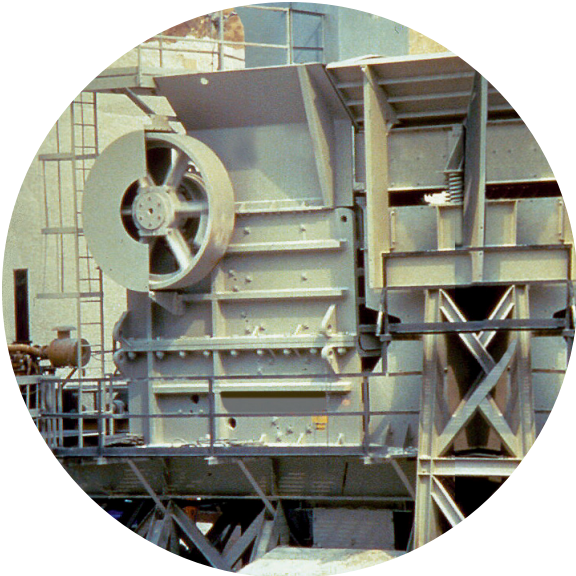

INCREASE YOUR EQUIPMENT UPTIME

In addition to high-quality bearings, engineered steel and mechanical power transmission components, we provide valuable integrated products and services. For example, we offer repair services and monitoring equipment that can alert you to problems before they impact your uptime.

Additionally, we offer a broad selection of seals, premium lubricants, lubricators, couplings and chain to keep your operations moving smoothly.

Our 10 technology centers in the United States, Europe and Asia help pioneer tomorrow's innovations with extensive basic and applied scientific research programs. Through internal development and strategic acquisition of innovative companies, we continue to expand our portfolio of highly engineered bearings, steel and components.



RUGGED TIMKEN® HOUSED UNITS HELP PROTECT YOUR BEARINGS

When you choose sturdy Timken housings, your bearings can keep rolling smoothly, even in harsh environments impacted by dirt, debris, water and other contaminants. Timken engineers designed special housings to withstand tough challenges on the job.

Protected inside durable cast iron, ductile iron or steel, our highly engineered Timken® ball and roller bearings work hard to help you manufacture and transport materials, without excessive maintenance due to contaminants.

Choose from our selection of housed units designed with ball, tapered and spherical bearings. Select enhancements like Timken® seals, lubricants and housing covers best suited for each task. Our engineers help you choose the right combination of bearings and accessories to extend bearing life, increase uptime and reduce maintenance costs.

Of course, you can interchange existing products with Timken housed units because our bolt holes and shaft centerline dimensions are designed to conform to industry standards.

Timken® housed units reflect our strengths in metallurgy, engineering and manufacturing. We ensure that all our bearings meet the Timken standard for quality.



TIMKEN® SNT SPLIT PLUMMER BLOCKS CARRY HEAVY LOADS

Timken® SNT split plummer blocks are available in metric sizes. Their rugged cast iron, ductile iron or cast steel designs stand up to a range of industrial environments. Our Timken SNT plummer blocks have separate, matched caps and bases. In larger sizes where plummer blocks are heavier, this split-block design eases installation. Remove the cap using a pry-tool slot for bearing inspection, service and replacement.

Available in a variety of metric shaft sizes, Timken SNT plummer block units offer the choice of tapered-bore design for easy mounting or straight-bore design for better axial location. The block can be converted from fixed to float by adding or removing the locating rings. A variety of sealing options help protect against contamination including all-purpose elastomer seals, deflection-type V-ring seals, precision labyrinth seals and heavy-duty taconite seals for highly contaminated environments.

TYPICAL INDUSTRIES AND APPLICATIONS

Use Timken SNT plummer blocks in power generation (coal), mining, aggregate, cement, metals, pulp, paper and other forestry operations, water treatment and food processing industries. Applications include warehousing, conveyors, bulk material handling and industrial fans and blowers.



TIMKEN® SAF SPLIT PILLOW BLOCKS HANDLE HEAVY LOADS

Timken® SAF split pillow blocks are available in imperial sizes. Their rugged cast iron, ductile iron or cast steel designs stand up to a range of industrial environments. Our Timken SAF blocks have separate, matched caps and bases. In larger sizes where pillow blocks are heavier, this split-block design eases installation. Remove the cap using a pry-tool slot for bearing inspection, service and replacement.

Available in a variety of imperial shaft sizes, Timken SAF units offer the choice of tapered-bore design for easy mounting or straight-bore design for better axial location. The block can be converted from fixed to float by removing the locating ring. Several sealing options protect against contamination, including our standard seal, which is a precision aluminum triple-ring labyrinth seal.

TYPICAL INDUSTRIES AND APPLICATIONS

Use Timken SAF housed bearings in power generation (coal), mining, aggregate, cement, metals, pulp, paper and other forestry operations, water treatment and food processing industries. Applications include warehousing, conveyors, bulk material handling and industrial fans and blowers.



TIMKEN® SPHERICAL ROLLER BEARING SOLID-BLOCK HOUSED UNITS WITHSTAND HARSH CONDITIONS

Timken® spherical roller bearing solid-block housed units stand up to rugged conditions. Composed of solid steel, they withstand most falling debris and handle up to ± 1.5 degrees of misalignment. The steel used in these products is up to two times stronger than cast iron, which may break or pound out in tough applications.

Timken spherical roller bearing solid-block housed units come in five locking configurations: single and double set screws, eccentric locks for reversing applications, tapered-adaptor locks and double-tapered locks.

Choose from three sealing options: labyrinth seals (for high-speed, high-temperature applications) and triple-lip seals made of either nitrile or urethane. Timken® steel auxiliary covers provide an extra layer of protection, and they can be filled with Timken lubricants.

TYPICAL INDUSTRIES AND APPLICATIONS

Use Timken spherical roller bearing solid-block housed units in metals mills, aggregate and cement, mining, power generation, agriculture, pulp, paper, sawmills and other forest industries.



TIMKEN® TYPE E HOUSED UNITS REPEL CONTAMINANTS, ENHANCE PERFORMANCE

Timken® Type E tapered roller bearing housed units feature double-lip seals and locking collars that protect against water and other contaminants. This double-lip seal design blocks debris and retains grease better than single-lip or triple-lip seals, according to Timken 2012 laboratory tests.

Its cast-iron exterior includes a corrosion-resistant electro-coat finish for the housing and collar offering a more durable shield than industry-standard powder coating or black oxide. Set screws with nylon patches reduce back-out, even in rigorous applications.

Premium Timken® tapered roller bearings inside Type E housings are manufactured with advanced technology that results in longer predicted useful bearing life than other housed units with standard bearings. Designed with optimized bearing profiles and improved surface finishes, Timken tapered roller bearings operate efficiently within the housing.

TYPICAL INDUSTRIES AND APPLICATIONS

Use Timken Type E housings for pulp and paper, power generation, mining, cement and aggregate industries. Our Type E housed units also are widely used in equipment for air-handling and treatment of water and waste water. Other common machine applications include mixers, washers, shredders, mills and oven/furnace roller beds.



TIMKEN® BALL HOUSED UNITS OFFER EASY INSTALLATION, FLEXIBLE OPTIONS

Timken® ball housed units, available in a variety of sizes and types, feature wide-inner-ring ball bearings that provide additional shaft support and locking options. The Timken® wide-inner-ring ball bearing is designed for straight shafts and can be positioned without shoulders, locknuts or adapters.

For easy installation, our ball housed units can be ordered pre-assembled with bearings, housings, seals and locking systems. Choose from pillow blocks, flanged cartridges, take-up units and cylindrical cartridges. Our cast-iron, pressed-steel and other optional materials give you durable choices for the exterior covers. Timken® locking options include set screws, self-locking collars and concentric collars.

Timken® Shaft Guarding Technology™ deters set-screw damage to shafts by placing a hardened band in the groove along the inner ring of the bearing. The set screws press against the band to transfer gripping pressure onto the shaft, preventing nicks, as well as raised-metal or permanent shaft damage. The stainless-steel band resists corrosion on the shaft. This system is particularly helpful for applications where it would be expensive and time-consuming to replace shafts.

TYPICAL INDUSTRIES AND APPLICATIONS

Use Timken ball bearing housed units in agricultural applications, fans, blowers, food processing devices and conveyors.





HOW TO USE THIS CATALOG

We designed this catalog to help you find the Timken housed units best suited to your specifications.

Timken offers an extensive range of bearings and accessories in both imperial and metric sizes. For your convenience, size ranges are indicated in millimeters and inches. Contact your Timken engineer to learn more about our complete line for the special needs of your application.

This publication contains dimensions, tolerances and load ratings, as well as engineering sections describing fitting practices for shafts and housings, internal clearances, materials and other bearing features. It provides valuable assistance in the initial consideration of the type and characteristics of the bearings that may best suit your particular needs.

ISO and ANSI/ABMA, as used in this publication, refer to the International Organization for Standardization and the American National Standards Institute/American Bearing Manufacturers Association.

Updates are made periodically to this catalog. Visit www.timken.com for the most recent version of the Timken® SNT Plummer Block Catalog.

DISCLAIMER

This catalog is provided solely to give you analysis tools and data to assist you in your product selection. Product performance is affected by many factors beyond the control of Timken. Therefore, you must validate the suitability and feasibility of all product selections.

Timken products are sold subject to Timken terms and conditions of sale, which include our limited warranty and remedy. You can find these at <http://www.timken.com/en-us/purchase/Pages/TermsandConditionsofSale.aspx>.

Please consult with your Timken engineer for more information and assistance.

Every reasonable effort has been made to ensure the accuracy of the information in this writing, but no liability is accepted for errors, omissions or for any other reason.

SHELF LIFE AND STORAGE OF GREASE-LUBRICATED BEARINGS AND COMPONENTS

To help you get the most value from our products, Timken provides guidelines for the shelf life of grease-lubricated ball and roller bearings, components and assemblies. Shelf life information is based on Timken and industry test data and experience.

SHELF LIFE POLICY

Shelf life should be distinguished from lubricated bearing/component design life as follows:

- Shelf life of the grease-lubricated bearing/component represents the period of time prior to use or installation.
- The shelf life is a portion of the anticipated aggregate design life. It is impossible to accurately predict design life due to variations in lubricant bleed rates, oil migration, operating conditions, installation conditions, temperature, humidity and extended storage.
- Shelf life values, available from Timken, represent a maximum limit and assume adherence to the storage and handling guidelines suggested in this catalog or by a Timken associate. Deviations from the Timken storage and handling guidelines may reduce shelf life. Any specification or operating practice that defines a shorter shelf life should be used.

Timken cannot anticipate the performance of the grease lubricant after the bearing or component is installed or placed in service.

TIMKEN IS NOT RESPONSIBLE FOR THE SHELF LIFE OF ANY BEARING/COMPONENT LUBRICATED BY ANOTHER PARTY.

European REACH Compliance

Timken lubricants, greases and similar products sold in standalone containers or delivery systems are subject to the European REACH (**R**egistration, **E**valuation, **A**uthorization and **R**estriction of **C**hemicals) directive. For import into the European Union, Timken can sell and provide only those lubricants and greases that are registered with ECHA (**E**uropean **C**hemical **A**gency). For further information, please contact your Timken engineer.





STORAGE

Timken suggests the following storage guidelines for our finished products (bearings, components and assemblies, referred to as “products”):

- Unless directed otherwise by Timken, products should be kept in their original packaging until they are ready to be placed into service.
- Do not remove or alter any labels or stencil markings on the packaging.
- Products should be stored in such a way that the packaging is not pierced, crushed or otherwise damaged.
- After a product is removed from its packaging, it should be placed into service as soon as possible.
- When removing a product that is not individually packaged from a bulk pack container, the container should be resealed immediately after the product is removed.
- Do not use product that has exceeded its shelf life as defined in the Timken shelf life guidelines statement.
- The storage area temperature should be maintained between 0° C (32° F) and 40° C (104° F); temperature fluctuations should be minimized.
- The relative humidity should be maintained below 60 percent and the surfaces should be dry.
- The storage area should be kept free from airborne contaminants such as, but not limited to, dust, dirt, harmful vapors, etc.
- The storage area should be isolated from undue vibration.
- Extreme conditions of any kind should be avoided.

Due to the fact that Timken is not familiar with your particular storage conditions, we strongly suggest following these guidelines. However, you may be required by circumstances or applicable government requirements to adhere to stricter storage requirements.

Most bearing components typically ship protected with a corrosion-preventive compound that is not a lubricant. These components may be used in oil-lubricated applications without removal of the corrosion-preventive compound. When using some specialized grease lubrications, we advise you to remove the corrosion-preventive compound before packing the bearing components with suitable grease.

Be careful in selecting lubrication, however, since different lubricants are often incompatible.

When you receive a bearing or plummer block shipment, do not remove products from their packaging until they are ready for mounting so they do not become corroded or contaminated.

Store bearings and bearing housings in an appropriate atmosphere so they remain protected for the intended period.



**WARNING**

Failure to observe the following warnings could create a risk of death or serious injury.

Proper maintenance and handling practices are critical. Failure to follow selection recommendations and installation instructions and to maintain proper lubrication can result in equipment failure.

Overheated bearings can ignite explosive atmospheres. Special care must be taken to properly select, install, maintain, and lubricate housed unit bearings that are used in or near atmospheres that may contain explosive levels of combustible gases or accumulations of dust such as grain, coal, or other combustible materials. Consult your equipment designer or supplier for installation and maintenance instructions.

If hammer and bar are used for installation or removal of a part, use a mild steel bar (e.g., 1010 or 1020 grade). Mild steel bars are less likely to cause release of high-speed fragments from the hammer, bar or the part being removed.

CAUTION

Failure to follow these cautions may result in property damage.

Do not use damaged housed units.

NOTE

Do not use excessive force when mounting or dismounting the unit.

Follow all tolerance, fit, and torque recommendations.

Always follow the Original Equipment Manufacturer's installation and maintenance guidelines.

Ensure proper alignment.

Never weld housed units.

Do not heat components with an open flame.

Do not operate at bearing temperatures above 121° C (250° F).

Warnings for this product line are in this catalog and posted on www.timken.com/warnings.

TIMKEN® SNT SPLIT PLUMMER BLOCKS DELIVER PERFORMANCE

The Timken® SNT plummer blocks metric product line is available with a variety of components and accessories that allow for customizable solutions. SNT split plummer blocks are available in rugged cast iron, ductile iron or cast steel to match a range of industrial environments and applications. Our Timken SNT plummer blocks have separate, matched caps and bases. These housings feature multiple design attributes to ease installation, including center marks for easier alignment and dimples for positioning pins and mounting bolt holes. Remove the cap using a pry-tool slot for bearing inspection, service and replacement.

Available in a variety of shaft sizes, Timken SNT plummer blocks offer the choice of tapered-bore design for easy mounting or a straight-bore design for better axial location. The block can be converted from fixed to float by adding or removing locating rings. Sealing options for the Timken SNT include double-lip, labyrinth, V-ring and taconite designs.

TYPICAL INDUSTRIES AND APPLICATIONS

Common uses include processing and material handling equipment found in many industries, including power generation (coal), mining, aggregate, cement, metal mills, pulp, paper and other forestry operations, water treatment and food processing. Applications include conveyors, bulk material handling, industrial fans and blowers.

Engineering	17
Lubrication	37
SNT Plummer Block Nomenclature	50
SNT Plummer Block Introduction	51
Seals	53
SNT Plummer Block Installation Guides	55
SNT Plummer Block Product Data Tables.....	60
Spherical Roller Bearing Nomenclature	84
Spherical Roller Bearing Product Data Tables.....	85
SNT Spherical Roller Bearing Metric Accessories.....	93

Updates are made periodically to this catalog. Visit www.timken.com for the most recent version of the Timken® SNT Plummer Block Catalog (order no. 10624).



ENGINEERING

The following topics are covered within this engineering section:

- Spherical roller bearing design types.
- Shaft fitting practice and mounting recommendations.

This engineering section is not intended to be comprehensive, but does serve as a useful guide in spherical roller bearing and SNT plummer block housing selection.

To view the complete engineering catalog, please visit www.timken.com. To order the catalog, please contact your Timken engineer and request a copy of the Timken Engineering Manual (order no. 10424).

Radial Spherical Roller Bearing Types and Cages.....	18
Metric System Tolerances.....	18
Spherical Roller Bearing Mounting, Fitting, Setting and Installation.....	21
Shaft Fits for Cylindrical Bore Bearings.....	29
Fitting Practice Tables.....	30

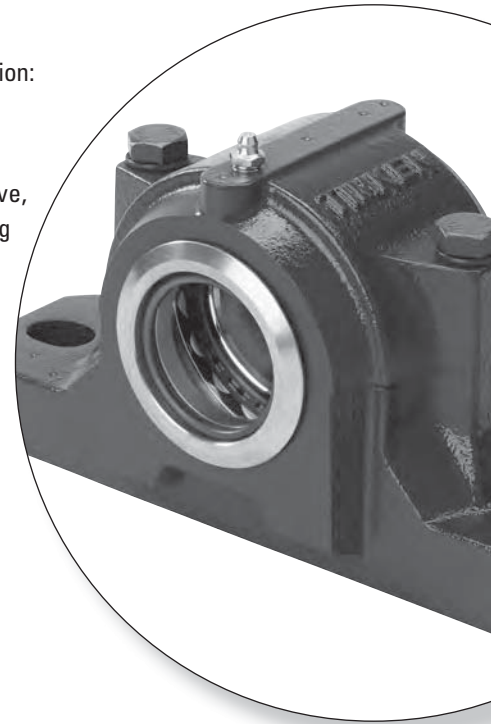

RADIAL SPHERICAL ROLLER BEARING TYPES AND CAGES

The principle styles of radial spherical roller bearings that Timken offers are:

- ≤600 mm O.D.: EJ, EM and EMB
- ≥600 mm O.D.: YMB

Above suffixes correspond to different types of designs depending on bearing size and geometry. The main difference is the cage design used in the assembly. Spherical roller bearings with an EJ cage suffix are fitted with a stamped-steel cage. YM/EM/YMB suffixes are used with brass cage designs.

The newly redesigned Timken® EJ, EM and EMB bearings offer higher load ratings, increased thermal speed ratings and reduced

operating temperatures compared to the previous offering.

In addition to these improvements, cage designs vary between the different styles as noted below.

Style	Cage Design
EJ	Land-riding steel cage; one per row
EM	Roller-riding one-piece brass cage
EMB/YMB	Land-riding one-piece brass cage

Most Timken® spherical roller bearings are available with a cylindrical bore as well as a tapered bore. Tapered bore bearing part numbers are designated with a K suffix.

METRIC SYSTEM TOLERANCES

Spherical roller bearings are manufactured to a number of specifications, with each having classes that define tolerances on dimensions such as bore, O.D., width and runout. Metric bearings have been manufactured to corresponding standard negative tolerances.

The following table summarizes the different specifications and classes for spherical roller bearings and other available Timken

bearing lines. For the purposes of this catalog, ISO specifications are shown for spherical roller bearings.

Boundary dimension tolerances for spherical roller bearing usage are listed in the following tables. These tolerances are provided for use in selecting bearings for general applications, in conjunction with the bearing mounting and fitting practices offered in later sections.

TABLE 1. BEARING SPECIFICATIONS AND CLASSES

System	Specification	Bearing Type	Standard Bearing Class		Precision Bearing Class			
			P0	P6	P5	P4	P2	–
Metric	ISO/DIN	All Bearing Types	P0	P6	P5	P4	P2	–
Imperial	ABMA	Spherical	RBEC 1	RBEC 3	RBEC 5	RBEC 7	RBEC 9	–

Standard Timken radial spherical roller bearings maintain normal tolerances according to ISO 492. Tables 2 and 3 list the critical tolerances for these bearing types. Timken SNT housings are used with bearings that conform to ISO P0, or standard tolerances.

The term deviation is defined as the difference between a single ring dimension and the nominal dimension. For metric tolerances, the nominal dimension is at a +0 mm tolerance. The deviation is the tolerance range for the listed parameter. Variation is defined as the difference between the largest and smallest measurements of a given parameter for an individual ring.

TABLE 2. SPHERICAL ROLLER BEARING TOLERANCES – INNER RING (METRIC)⁽¹⁾

Bearing Bore		Bore Deviation ⁽²⁾ Δ_{dmp}			Width Variation V_{BS}			Radial Runout K_{ia}			Face Runout with Bore S_d	Axial Runout S_{ia}	Width Deviation Inner & Outer Rings ⁽²⁾ Δ_{Bs} and Δ_{Cs}	
Over	Incl.	P0	P6	P5	P0	P6	P5	P0	P6	P5	P5	P5	P0, P6	P5
mm	mm	mm	mm	mm	mm	mm	mm	mm	mm	mm	mm	mm	mm	mm
in.	in.	in.	in.	in.	in.	in.	in.	in.	in.	in.	in.	in.	in.	in.
2.5000 0.0984	10.000 0.3937	-0.008 -0.0003	-0.007 -0.0003	-0.005 -0.0002	0.015 0.0006	0.015 0.0006	0.005 0.0002	0.010 0.0004	0.006 0.0002	0.004 0.0002	0.007 0.0003	0.007 0.0003	-0.120 -0.0047	-0.040 -0.0157
10.000 0.3937	18.000 0.7087	-0.008 -0.0003	-0.007 -0.0003	-0.005 -0.0002	0.020 0.0008	0.020 0.0008	0.005 0.0002	0.010 0.0004	0.007 0.0003	0.004 0.0002	0.007 0.0003	0.007 0.0003	-0.120 -0.0047	-0.080 -0.0031
18.000 0.7087	30.000 1.1811	-0.010 -0.0004	-0.008 -0.0003	-0.006 -0.0002	0.020 0.0008	0.020 0.0008	0.005 0.0002	0.013 0.0005	0.008 0.0003	0.004 0.0002	0.008 0.0003	0.008 0.0003	-0.120 -0.0047	-0.120 -0.0047
30.000 1.1811	50.000 1.9685	-0.012 -0.0005	-0.010 -0.0004	-0.008 -0.0003	0.020 0.0008	0.020 0.0008	0.005 0.0002	0.015 0.0006	0.010 0.0004	0.005 0.0002	0.008 0.0003	0.008 0.0003	-0.120 -0.0047	-0.120 -0.0047
50.000 1.9685	80.000 3.1496	-0.015 -0.0006	-0.012 -0.0005	-0.009 -0.0004	0.025 0.0010	0.025 0.0010	0.006 0.0002	0.020 0.0008	0.010 0.0004	0.005 0.0002	0.008 0.0003	0.008 0.0003	-0.150 -0.0059	-0.150 -0.0059
80.000 3.1496	120.000 4.7244	-0.020 -0.0008	-0.015 -0.0006	-0.010 -0.0004	0.025 0.0010	0.025 0.0010	0.007 0.0003	0.025 0.0010	0.013 0.0005	0.006 0.0002	0.009 0.0004	0.009 0.0004	-0.200 -0.0079	-0.200 -0.0079
120.000 4.7244	150.000 5.9055	-0.025 -0.0010	-0.018 -0.0007	-0.013 -0.0005	0.030 0.0012	0.030 0.0012	0.008 0.0003	0.030 0.0012	0.018 0.0007	0.008 0.0003	0.010 0.0004	0.010 0.0004	-0.250 -0.0098	-0.250 -0.0098
150.000 5.9055	180.000 7.0866	-0.025 -0.0010	-0.018 -0.0007	-0.013 -0.0005	0.030 0.0012	0.030 0.0012	0.008 0.0003	0.030 0.0012	0.018 0.0007	0.008 0.0003	0.010 0.0004	0.010 0.0004	-0.250 -0.0098	-0.250 -0.0098
180.000 7.0866	250.000 9.8425	-0.030 -0.0012	-0.022 -0.0009	-0.015 -0.0006	0.030 0.0012	0.030 0.0012	0.010 0.0004	0.040 0.0016	0.020 0.0008	0.010 0.0004	0.011 0.0004	0.013 0.0005	-0.300 -0.0018	-0.300 -0.0018
250.000 9.8425	315.000 12.4016	-0.035 -0.0014	-0.025 -0.0010	-0.018 -0.0007	0.035 0.0014	0.035 0.0014	0.013 0.0005	0.050 0.0020	0.025 0.0010	0.013 0.0005	0.013 0.0005	0.015 0.0006	-0.350 -0.0138	-0.350 -0.0138
315.000 12.4016	400.000 15.7480	-0.040 -0.0016	-0.030 -0.0012	-0.023 -0.0009	0.040 0.0016	0.040 0.0016	0.015 0.0006	0.060 0.0024	0.030 0.0012	0.015 0.0006	0.015 0.0006	0.020 0.0008	-0.400 -0.0157	-0.400 -0.0157
400.000 15.7480	500.000 19.6850	-0.045 -0.0018	-0.035 -0.0014	–	0.050 0.0020	0.045 0.0018	–	0.065 0.0026	0.035 0.0014	–	–	–	-0.450 -0.0177	–
500.000 19.6850	630.000 24.8031	-0.050 -0.0020	-0.040 -0.0016	–	0.060 0.0024	0.050 0.0020	–	0.070 0.0028	0.040 0.0016	–	–	–	-0.500 -0.0197	–
630.000 24.8031	800.000 31.4961	-0.075 -0.0030	–	–	0.070 0.0028	–	–	0.080 0.0031	–	–	–	–	-0.750 -0.0295	–

⁽¹⁾Symbol definitions are found on pages 32-33 of the Timken Engineering Manual (order no. 10424).

⁽²⁾Tolerance range is from +0 to value listed.

NOTE: Tolerance and shaft diameters are shown in the table as variances from nominal bearing bore.

TABLE 3. SPHERICAL ROLLER BEARING TOLERANCES – OUTER RING (METRIC)⁽¹⁾

Bearing O.D.		Outside Deviation ⁽²⁾			Width Variation		Radial Runout			Axial Runout	Outside Diameter Runout With Face
Over	Incl.	Δ_{Dmp}			V_{CS}		K_{ea}			S_{ea}	S_D
		P0	P6	P5	P0	P6	P0	P6	P5	P5	P5
mm	mm	mm	mm	mm	mm	mm	mm	mm	mm	mm	mm
in.	in.	in.	in.	in.	in.	in.	in.	in.	in.	in.	in.
0.000 0.0000	18.000 0.7087	-0.008 -0.0003	-0.007 -0.0003	-0.005 -0.0002	0.015 0.0006	0.005 0.0002	0.015 0.0006	0.008 0.0003	0.005 0.0002	0.008 0.0003	0.008 0.0003
18.000 0.7087	30.000 1.1811	-0.009 -0.0004	-0.008 -0.0003	-0.006 -0.00024	0.020 0.0008	0.005 0.0002	0.015 0.0006	0.009 0.0004	0.006 0.00024	0.008 0.0003	0.008 0.0003
30.000 1.1811	50.000 1.9685	-0.011 -0.0004	-0.009 -0.0004	-0.007 -0.0003	0.020 0.0008	0.005 0.0002	0.020 0.0008	0.010 0.0004	0.007 0.0003	0.008 0.0003	0.008 0.0003
50.000 1.9685	80.000 3.1496	-0.013 -0.0005	-0.011 -0.0004	-0.009 -0.0004	0.025 0.0010	0.006 0.00024	0.025 0.0010	0.013 0.0005	0.008 0.0003	0.010 0.0004	0.008 0.0003
80.000 3.1496	120.000 4.7244	-0.015 -0.0006	-0.013 -0.0005	-0.010 -0.0004	0.025 0.0010	0.008 0.0003	0.035 0.0014	0.018 0.0007	0.010 0.0004	0.011 0.0004	0.009 0.0004
120.000 4.7244	150.000 5.9055	-0.018 -0.0007	-0.015 -0.0006	-0.011 -0.0004	0.030 0.0012	0.008 0.0003	0.040 0.0016	0.020 0.0008	0.011 0.0004	0.013 0.0005	0.010 0.0004
150.000 5.9055	180.000 7.0866	-0.025 -0.0010	-0.018 -0.0007	-0.013 -0.0005	0.030 0.0012	0.008 0.0003	0.045 0.0018	0.023 0.0009	0.013 0.0005	0.014 0.0006	0.010 0.0004
180.000 7.0866	250.000 9.8425	-0.030 -0.0012	-0.020 -0.0008	-0.015 -0.0006	0.030 0.0012	0.010 0.0004	0.050 0.0020	0.025 0.0010	0.015 0.0006	0.015 0.0006	0.011 0.0004
250.000 9.8425	315.000 12.4016	-0.035 -0.0014	-0.025 -0.0010	-0.018 -0.0007	0.035 0.0014	0.011 0.0004	0.060 0.0024	0.030 0.0012	0.018 0.0007	0.018 0.0007	0.013 0.0005
315.000 12.4016	400.000 15.7480	-0.040 -0.0016	-0.028 -0.0011	-0.020 -0.0008	0.040 0.0016	0.013 0.0005	0.070 0.0028	0.035 0.0014	0.020 0.0008	0.020 0.0008	0.013 0.0005
400.000 15.7480	500.000 19.6850	-0.045 -0.0018	-0.033 -0.0013	-0.023 -0.0009	0.045 0.0018	0.015 0.0006	0.080 0.0031	0.040 0.0016	0.023 0.0009	0.023 0.0009	0.015 0.0006
500.000 19.6850	630.000 24.8031	-0.050 -0.0020	-0.038 -0.0015	-0.028 -0.0011	0.050 0.0020	0.018 0.0007	0.100 0.0039	0.050 0.0020	0.025 0.0010	0.025 0.0010	0.018 0.0007
630.000 24.8031	800.000 31.4961	-0.075 -0.0030	-0.045 -0.0018	-0.035 -0.0014	–	0.020 0.0008	0.120 0.0047	0.060 0.0024	0.030 0.0012	0.030 0.0012	0.020 0.0008
800.000 31.4961	1000.000 39.3701	-0.100 -0.0040	-0.060 -0.0024	–	–	–	0.140 0.0055	0.075 0.0030	–	–	–
1000.000 39.3701	1250.000 49.2126	-0.125 -0.0050	–	–	–	–	0.160 0.0063	–	–	–	–

⁽¹⁾Symbol definitions are found on pages 32-33 of the Timken Engineering Manual (order no. 10424).

⁽²⁾Tolerance range is from +0 to value listed.

NOTE: Tolerance and shaft diameters are shown in the table as variances from nominal bearing bore.

SPHERICAL ROLLER BEARING MOUNTING, FITTING, SETTING AND INSTALLATION

MOUNTING

Typically, spherical roller bearings are mounted in combination with another spherical roller bearing or a cylindrical roller bearing.

With spherical roller bearings, typically one bearing is fixed axially and the other is mounted with loose fits and axial clearance. This allows axial movement or float for environmental conditions such as uneven thermal growth between shaft and housing. In SNT housings, two or more locating rings can be used. With these ring(s) installed, a fixed bearing is achieved. When the ring(s) are removed, and provided the bearing is properly located in the housing, the bearing can float freely.

Fig. 1 shows a fixed split housing with a locating ring installed and a float bearing without the locating ring.

FITTING PRACTICE

Tables 6 through 8 on pages 29 through 35 list the recommended fitting practice for spherical roller bearing inner rings on shafts. The tables assume:

- The bearing is of normal precision.
- The shaft is solid and made from steel.
- The bearing seats are ground or turned to less than approximately 1.6 Ra finish.

The suggested fit symbols are in accordance with ISO 286. For help with suggested fitting practice, contact your Timken engineer.

As a general guideline, rotating inner rings should be applied with an interference fit. Loose fits may permit the inner rings to creep or turn, and wear the shaft and the backing shoulder. This wear may result in excessive bearing looseness and possible bearing and shaft damage. Additionally, abrasive metal particles resulting from creep or turning may enter into the bearing and cause damage and vibration.

The load conditions and bearing envelope dimensions should be used to select the suggested shaft fit from the tables.

Contact your Timken engineer if you require the specific fit practice used for a given SNT housing.



WARNING

Failure to observe the following warnings could create a risk of death or serious injury.

Proper maintenance and handling practices are critical. Always follow installation instructions and maintain proper lubrication.

Overheated bearings can ignite explosive atmospheres. Special care must be taken to properly select, install, maintain, and lubricate housed unit bearings that are used in or near atmospheres that may contain explosive levels of combustible gases or accumulations of dust such as from grain, coal, or other combustible materials. Consult your equipment designer or supplier for installation and maintenance instructions.

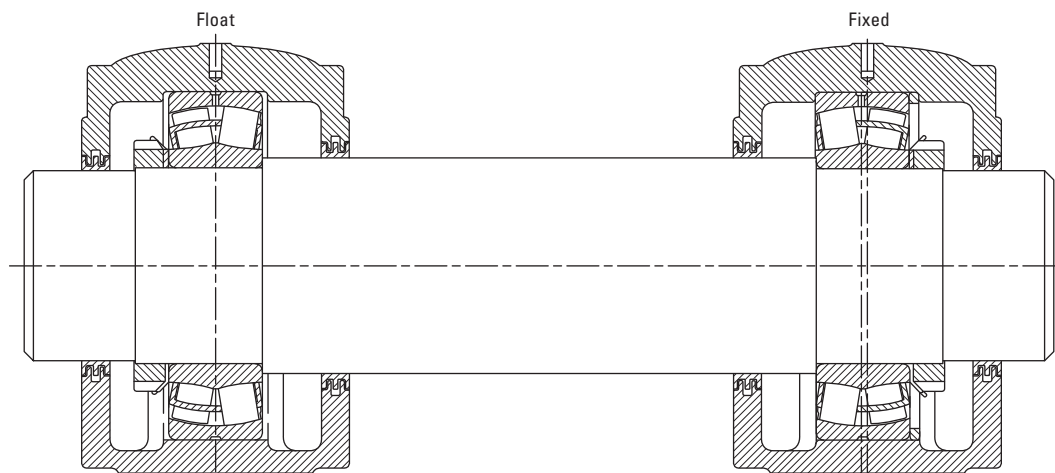

Fig. 1. Split housing showing fixed and float mounting.

TAPERED BORE DESIGNS

Typically, tapered bore bearings are selected to simplify shaft mounting and dismounting. Since the spherical roller bearing is not separable, mounting can be simplified by use of an adapter sleeve with a cylindrical bore and tapered O.D. A tapered bore roller bearing also can be mounted directly onto a tapered shaft.

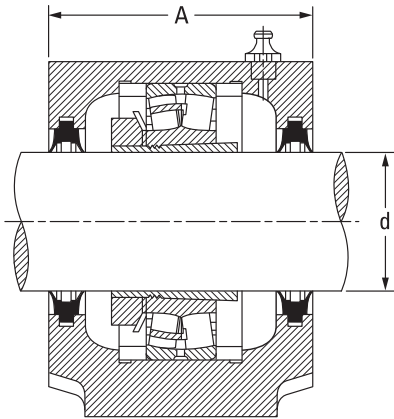

Fig. 2. Spherical roller bearing mounted with an adapter sleeve.

Bearings with a tapered bore typically require a tighter fit on the shaft than bearings with a cylindrical bore. A locknut is typically used to drive the inner ring up a tapered shaft sleeve. The locknut position is then secured by use of a lockwasher or lockplate. Timken offers a wide range of accessories to ease the assembly of spherical roller bearings with a tapered bore (see page 25). For approximating the clearance loss for axial drive-up, an 85 percent radial loss approximation can be used. That is, the radial clearance loss per axial drive-up can roughly be approximated as $71 \mu\text{m}/\text{mm}$ for a 1:12 tapered. Table 5 on page 24 provides a direct relation between suggested RIC (radial internal clearance) reduction due to installation and the corresponding axial displacement of the inner ring.

SETTING

To achieve appropriate operating clearance, attention must be paid to the effects that fitting practice and thermal gradients have within the bearing.

FITTING PRACTICE

- An interference fit between the inner ring and a solid steel shaft will reduce the radial clearance within the bearing by approximately 80 percent of the fit.

NOTE

It is critical to select the RIC that allows for this reduction.

- Spherical roller bearings with a tapered bore require a slightly greater interference fit on the shaft than a cylindrical bore bearing.

THERMAL GRADIENTS

- Thermal gradients within the bearing are primarily a function of the bearing rotational speed. As speed increases, thermal gradients increase, thermal growth occurs and the radial clearance is reduced.
- As a rule of thumb, radial clearance should be increased for speeds in excess of 70 percent of the speed rating.

For help selecting the correct radial internal clearance for your application, consult with your Timken engineer.

Radial internal clearance tolerances are listed in tables 4 and 5 for spherical roller bearings.

Spherical roller bearings are ordered with a specified standard or non-standard radial internal clearance value. The standard radial internal clearances are designated as C2, C0 (normal), C3, C4 or C5 and are in accordance with ISO 5753. C2 represents the minimum clearance and C5 represents the maximum clearance. Non-standardized values also are available by special request.

The clearance required for a given application depends on the desired operating precision, the rotational speed of the bearing, and the fitting practice used. SNT housings are commonly used with C0 or C3 clearance bearing, though other clearances may be ordered for specific applications. Typically, larger clearance reduces the operating load zone of the bearing, increases the maximum roller load, and reduces the bearing's expected life. However, a spherical roller bearing that has been put into a preload condition can experience premature bearing damage caused by excessive heat generation and/or material fatigue. As a general guideline, spherical roller bearings should not operate in a preloaded condition.

TABLE 4. RADIAL INTERNAL CLEARANCE LIMITS – SPHERICAL ROLLER BEARINGS – CYLINDRICAL BORE

Bore (Nominal)		Cylindrical Bore						Typical Reduction of RIC Due to Installation		Typical RIC After Installation
		Normal CO		C4		C5				
		Min.	Max.	Min.	Max.	Min.	Max.			
Over	Incl.	C2		C3		C5		Min.	Max.	Min.
mm in.	mm in.	mm in.	mm in.	mm in.	mm in.	mm in.	mm in.	mm in.	mm in.	mm in.
20 0.9449	30 1.1811	0.015 0.0006	0.025 0.001	0.04 0.0016	0.055 0.0022	0.075 0.003	0.095 0.0037	0.015 0.0006	0.02 0.0008	0.015 0.0006
30 1.1811	40 1.5748	0.015 0.0006	0.03 0.0012	0.045 0.0018	0.06 0.0024	0.08 0.0031	1 0.0039	0.02 0.0008	0.025 0.001	0.015 0.0006
40 1.5748	50 1.9685	0.02 0.0008	0.035 0.0014	0.055 0.0022	0.075 0.003	0.1 0.0039	0.125 0.0049	0.025 0.001	0.03 0.0012	0.02 0.0008
50 1.9685	65 2.5591	0.02 0.0008	0.04 0.0016	0.065 0.0026	0.09 0.0035	0.12 0.0047	0.15 0.0059	0.03 0.0012	0.038 0.0015	0.025 0.001
65 2.5591	80 3.1496	0.03 0.0012	0.05 0.002	0.08 0.0031	0.11 0.0043	0.145 0.0057	0.18 0.0071	0.038 0.0015	0.051 0.002	0.025 0.001
80 3.1496	100 3.9370	0.035 0.0014	0.06 0.0024	0.1 0.0039	0.135 0.0053	0.18 0.0071	0.225 0.0089	0.046 0.0018	0.064 0.0025	0.036 0.0014
100 3.9370	120 4.7244	0.04 0.0016	0.075 0.003	0.12 0.0047	0.16 0.0063	0.21 0.0083	0.26 0.0102	0.051 0.002	0.071 0.0028	0.051 0.002
120 4.7244	140 5.5118	0.05 0.002	0.095 0.0037	0.145 0.0057	0.19 0.0075	0.24 0.0094	0.3 0.0118	0.064 0.0025	0.089 0.0035	0.056 0.0022
140 5.5118	160 6.2992	0.06 0.0024	0.11 0.0043	0.17 0.0067	0.22 0.0087	0.28 0.011	0.35 0.0138	0.076 0.003	0.102 0.004	0.056 0.0022
160 6.2992	180 7.0866	0.065 0.0026	0.12 0.0047	0.18 0.0071	0.24 0.0094	0.31 0.0122	0.39 0.0154	0.076 0.003	0.114 0.0045	0.061 0.0024
180 7.0866	200 7.8740	0.07 0.0028	0.13 0.0051	0.2 0.0079	0.26 0.0102	0.34 0.0134	0.43 0.0169	0.089 0.0035	0.127 0.005	0.071 0.0028
200 7.8740	225 8.8582	0.08 0.0031	0.14 0.0055	0.22 0.0087	0.29 0.0114	0.38 0.015	0.47 0.0185	0.102 0.004	0.14 0.0055	0.076 0.003
225 8.8582	250 9.8425	0.09 0.0035	0.15 0.0059	0.24 0.0094	0.32 0.0126	0.42 0.0165	0.52 0.0205	0.114 0.0045	0.152 0.006	0.089 0.0035
250 9.8425	280 11.0236	0.1 0.0039	0.17 0.0067	0.26 0.0102	0.35 0.0138	0.46 0.0181	0.57 0.0224	0.114 0.0045	0.165 0.0065	0.102 0.004
280 11.0236	315 12.4016	0.11 0.0043	0.19 0.0075	0.28 0.011	0.37 0.0146	0.5 0.0197	0.63 0.0248	0.127 0.005	0.178 0.007	0.102 0.004
315 12.4016	355 13.9764	0.12 0.0047	0.2 0.0079	0.31 0.0122	0.41 0.0161	0.55 0.0217	0.69 0.0272	0.14 0.0055	0.19 0.0075	0.114 0.0045
355 13.9764	400 15.7480	0.13 0.0051	0.22 0.0087	0.34 0.0134	0.45 0.0177	0.6 0.0236	0.75 0.0295	0.152 0.006	0.203 0.008	0.127 0.005
400 15.7480	450 17.7165	0.14 0.0055	0.24 0.0094	0.37 0.0146	0.5 0.0197	0.66 0.026	0.82 0.0323	0.165 0.0065	0.216 0.0085	0.152 0.006
450 17.7165	500 19.6850	0.14 0.0055	0.26 0.0102	0.41 0.0161	0.55 0.0217	0.72 0.0283	0.9 0.0354	0.178 0.007	0.229 0.009	0.165 0.0065
500 19.6850	560 22.0472	0.15 0.0059	0.28 0.011	0.44 0.0173	0.6 0.0236	0.78 0.0307	1 0.0394	0.203 0.008	0.254 0.01	0.178 0.007
560 22.0472	630 24.8031	0.17 0.0067	0.31 0.0122	0.48 0.0189	0.65 0.0256	0.85 0.0335	1.1 0.0433	0.229 0.009	0.279 0.011	0.203 0.008
630 24.8031	710 27.9528	0.19 0.0075	0.35 0.0138	0.53 0.0209	0.7 0.0276	0.92 0.0362	1.19 0.0469	0.254 0.01	0.305 0.012	0.203 0.008
710 27.9528	800 31.4961	0.21 0.0083	0.39 0.0154	0.58 0.0228	0.77 0.0303	1.01 0.0398	1.3 0.0512	0.279 0.011	0.356 0.014	0.229 0.009
800 31.4961	900 35.4331	0.23 0.0091	0.43 0.0169	0.65 0.0256	0.86 0.0339	1.12 0.0441	1.44 0.0567	0.305 0.012	0.381 0.015	0.252 0.01
900 35.4331	1000 39.3701	0.26 0.0102	0.48 0.0189	0.71 0.028	0.93 0.0366	1.22 0.048	1.57 0.0618	0.356 0.014	0.432 0.017	0.279 0.011

NOTE: Tolerance and shaft diameters are shown in the table as variances from nominal bearing bore.

TABLE 5. RADIAL INTERNAL CLEARANCE LIMITS – SPHERICAL ROLLER BEARINGS – TAPERED BORE

Bore (Nominal)		Tapered Bore						Suggested Reduction of RIC Due to Installation		Axial Displacement of Inner Ring for RIC Reduction – Tapered Shaft ⁽¹⁾⁽²⁾				Suggested RIC After Installation ⁽¹⁾
		Normal CO		C4		C5				Taper 1:12		Taper 1:30		
		Min.	Max.	Min.	Max.	Min.	Max.			Min.	Max.	Min.	Max.	
Over	Incl.	Min.	Max.	Min.	Max.	Min.	Max.	Min.	Max.	Min.	Max.	Min.	Max.	Min.
mm	mm	mm	mm	mm	mm	mm	mm	mm	mm	mm	mm	mm	mm	mm
in.	in.	in.	in.	in.	in.	in.	in.	in.	in.	in.	in.	in.	in.	in.
20 0.9449	30 1.1811	0.02 0.0008	0.03 0.0012	0.04 0.0016	0.055 0.0022	0.075 0.003	0.095 0.0037	0.015 0.0006	0.02 0.0008	0.23 0.0091	0.30 0.0118	–	–	0.015 0.0006
30 1.1811	40 1.5748	0.025 0.001	0.035 0.0014	0.05 0.002	0.065 0.0026	0.085 0.0033	0.105 0.0041	0.02 0.0008	0.025 0.001	0.30 0.0118	0.38 0.0150	–	–	0.015 0.0006
40 1.5748	50 1.9685	0.03 0.0012	0.045 0.0018	0.06 0.0024	0.08 0.0031	0.1 0.0039	0.13 0.0051	0.025 0.001	0.03 0.0012	0.38 0.0150	0.46 0.0181	–	–	0.02 0.0008
50 1.9685	65 2.5591	0.04 0.0016	0.055 0.0022	0.075 0.003	0.095 0.0037	0.12 0.0047	0.16 0.0063	0.03 0.0012	0.038 0.0015	0.46 0.0181	0.56 0.0220	–	–	0.025 0.001
65 2.5591	80 3.1496	0.05 0.002	0.07 0.0028	0.095 0.0037	0.12 0.0047	0.15 0.0059	0.2 0.0079	0.038 0.0015	0.051 0.002	0.56 0.0220	0.76 0.0299	–	–	0.025 0.001
80 3.1496	100 3.9370	0.055 0.0022	0.08 0.003	0.11 0.0043	0.14 0.0055	0.18 0.0071	0.23 0.0091	0.046 0.0018	0.064 0.0025	0.68 0.0268	0.97 0.0382	–	–	0.036 0.0014
100 3.9370	120 4.7244	0.065 0.0026	0.1 0.0039	0.135 0.0053	0.17 0.0067	0.22 0.0087	0.28 0.011	0.051 0.002	0.071 0.0028	0.76 0.0299	1.07 0.0421	1.90 0.0748	2.54 0.1000	0.051 0.002
120 4.7244	140 5.5118	0.08 0.0031	0.12 0.0047	0.16 0.0063	0.2 0.0079	0.26 0.0102	0.33 0.013	0.064 0.0025	0.089 0.0035	0.89 0.0350	1.27 0.0500	2.29 0.0902	3.05 0.1201	0.056 0.0022
140 5.5118	160 6.2992	0.09 0.0035	0.13 0.0051	0.18 0.0071	0.23 0.0091	0.3 0.0118	0.38 0.015	0.076 0.003	0.102 0.004	1.14 0.0449	1.52 0.0598	2.67 0.1051	3.43 0.1350	0.056 0.0022
160 6.2992	180 7.0866	0.1 0.0039	0.14 0.0055	0.2 0.0079	0.26 0.0102	0.34 0.0134	0.43 0.0169	0.076 0.003	0.114 0.0045	1.14 0.0449	1.65 0.0650	2.67 0.1051	4.06 0.1598	0.061 0.0024
180 7.0866	200 7.8740	0.11 0.0043	0.16 0.0063	0.22 0.0087	0.29 0.0114	0.37 0.0146	0.47 0.0185	0.089 0.0035	0.127 0.005	1.40 0.0551	1.90 0.0748	3.05 0.1201	4.45 0.1752	0.071 0.0028
200 7.8740	225 8.8582	0.12 0.0047	0.18 0.0071	0.25 0.0098	0.32 0.0126	0.41 0.0161	0.52 0.0205	0.102 0.004	0.14 0.0055	1.52 0.0598	2.03 0.0799	3.56 0.1402	4.83 0.1902	0.076 0.003
225 8.8582	250 9.8425	0.14 0.0055	0.2 0.0079	0.27 0.0106	0.35 0.0138	0.45 0.0177	0.57 0.0224	0.114 0.0045	0.152 0.006	1.78 0.0701	2.29 0.0902	4.06 0.1598	5.33 0.2098	0.089 0.0035
250 9.8425	280 11.0236	0.15 0.0059	0.22 0.0087	0.3 0.0118	0.39 0.0154	0.49 0.0193	0.62 0.0244	0.114 0.0045	0.165 0.0065	1.78 0.0701	2.54 0.1000	4.06 0.1598	5.84 0.2299	0.102 0.004
280 11.0236	315 12.4016	0.17 0.0067	0.24 0.0094	0.33 0.013	0.43 0.0169	0.54 0.0213	0.68 0.0268	0.127 0.005	0.178 0.007	1.90 0.0748	2.67 0.1051	4.45 0.1752	6.22 0.2449	0.102 0.004
315 12.4016	355 13.9764	0.19 0.0075	0.27 0.0106	0.36 0.0142	0.47 0.0185	0.59 0.0232	0.74 0.0291	0.14 0.0055	0.19 0.0075	2.03 0.0799	2.79 0.1098	4.83 0.1902	6.60 0.2598	0.114 0.0045
355 13.9764	400 15.7480	0.21 0.0083	0.3 0.0118	0.4 0.0157	0.52 0.0205	0.65 0.0256	0.82 0.0323	0.152 0.006	0.203 0.008	2.29 0.0902	3.05 0.1201	5.33 0.2098	7.11 0.2799	0.127 0.005
400 15.7480	450 17.7165	0.23 0.0091	0.33 0.013	0.44 0.0173	0.57 0.0224	0.72 0.0283	0.91 0.0358	0.165 0.0065	0.216 0.0085	2.54 0.1000	3.3 0.1299	5.84 0.2299	7.62 0.3000	0.152 0.006
450 17.7165	500 19.6850	0.26 0.0102	0.37 0.0146	0.49 0.0193	0.63 0.0248	0.79 0.0311	1 0.0394	0.178 0.007	0.229 0.009	2.67 0.1051	3.43 0.1350	6.22 0.2449	8.00 0.3150	0.165 0.0065
500 19.6850	560 22.0472	0.29 0.0114	0.41 0.0161	0.54 0.0213	0.68 0.0268	0.87 0.0343	1.1 0.0433	0.203 0.008	0.254 0.01	3.05 0.1201	3.81 0.1500	7.11 0.2799	8.89 0.3500	0.178 0.007
560 22.0472	630 24.8031	0.32 0.0126	0.46 0.0181	0.6 0.0236	0.76 0.0299	0.98 0.0386	1.23 0.0484	0.229 0.009	0.279 0.011	3.43 0.1350	4.19 0.1650	8.00 0.3150	9.78 0.3850	0.203 0.008
630 24.8031	710 27.9528	0.35 0.0138	0.51 0.0201	0.67 0.0264	0.85 0.0335	1.09 0.0429	1.36 0.0535	0.254 0.01	0.305 0.012	3.81 0.1500	4.57 0.1799	8.89 0.3500	10.67 0.4201	0.203 0.008
710 27.9528	800 31.4961	0.39 0.0154	0.57 0.0224	0.75 0.0295	0.96 0.0378	1.22 0.048	1.5 0.0591	0.279 0.011	0.356 0.014	4.19 0.1650	5.33 0.2098	9.78 0.3850	12.45 0.4902	0.229 0.009
800 31.4961	900 35.4331	0.44 0.0173	0.64 0.0252	0.84 0.0331	1.07 0.0421	1.37 0.0539	1.69 0.0665	0.305 0.012	0.381 0.015	4.57 0.1799	5.72 0.2252	10.67 0.4201	13.33 0.5248	0.252 0.01
900 35.4331	1000 39.3701	0.49 0.0193	0.71 0.028	0.93 0.0366	1.19 0.0469	1.52 0.0598	1.86 0.0732	0.356 0.014	0.432 0.017	5.33 0.2100	6.48 0.2551	12.45 0.4902	15.11 0.5949	0.279 0.011

⁽¹⁾This displacement is valid for assembly of tapered bore bearings and is measured starting from a line-to-line fit of the bearing bore to the tapered shaft.

⁽²⁾1:12 Taper used for 222, 223, 230, 231, 232, 233, 239 series. 1:30 Taper used for 240, 241, 242 series. For sleeve mounting, multiply axial displacement values by 1.1 for 1:12 Taper or by 1.05 for 1:30 Taper. For questions on tapered shaft data, consult your Timken engineer.

NOTE: Axial displacement values apply to solid steel shafts or hollow shafts with bore diameter less than half the shaft diameter. For shaft materials other than steel, or for thin-walled shafts, please consult your Timken engineer.

NOTE: Tolerance and shaft diameters are shown in the table as variances from nominal bearing bore.

EXAMPLE #1 –**Calculating RIC Reduction Using a Spherical Roller Bearing with Tapered Bore**

Given bearing number 22328K C3 (140 mm bore with C3 clearance) is to be mounted on a tapered shaft. Using a set of feeler gages, RIC is measured at (see fig. 3):

$$\text{RIC} = 0.178 \text{ mm}$$

Suggested reduction of RIC due to installation = 0.064 mm – 0.089 mm, found in table 5 on page 24.

Calculate the clearance after mounting (see fig. 4):

$$0.178 \text{ mm} - 0.076 \text{ mm} = 0.102 \text{ mm}$$

For this example, the value of 0.076 mm was obtained by taking the mid-range value of the upper and lower limits found in the tables on page 24.

Therefore, the locknut should be tightened until RIC reaches 0.102 mm.

It also should be noted that the value obtained by reading the suggested RIC after installation directly from the table is 0.056 mm.



Fig. 3. Measure RIC before installation.



Fig. 4. During mounting, the RIC should be checked at the unloaded roller.

This differs from the value calculated in the example. The value taken directly from the table is provided as a minimum value. It is not suggested to use a calculated value that falls below this minimum.

EXAMPLE #2 –**Calculating RIC Reduction Using a Spherical Roller Bearing with Cylindrical Bore****Observations:**

- Bearing 22230EM, nominal 150 mm bore and 270 mm O.D., standard class, operating at 1200 RPM.
- Float bearing position so the stationary O.D. should be free to move in SNT housing, with the locating ring removed.
- With shaft/inner ring rotation and the moderate loading 0.09C, the bore should be tight fit.

We can use the nominal fit charts in table 6 on page 29 (shaft fit) to help guide our ISO fit selection.

Shaft Fit at 150 mm Bore: ISO p6

From the shaft fit chart at 150 mm nominal bore at p6 (table 8, page 34), the shaft tolerance is nominal +0.043 to +0.068 mm. Therefore we have the following bore range:

$$\text{max. shaft} = 150.068 \text{ mm}$$

$$\text{min. shaft} = 150.043 \text{ mm}$$

This yields a shaft fit:

$$\begin{aligned} \text{max. fit} &= \text{max. shaft} - \text{min. bore} \\ &= 150.068 - 149.075 \\ &= 0.093 \text{ mm tight} \end{aligned}$$

$$\begin{aligned} \text{min. fit} &= \text{min. shaft} - \text{max. bore} \\ &= 150.043 - 150.000 \\ &= 0.043 \text{ mm tight} \end{aligned}$$

For the primary selection of RIC, the major parameters are the bearing speed and the fits. For our example, we know that the shaft fit is 0.043 mm tight to 0.093 mm tight. We know the housing

fit is loose. We also know that the bearing speed is 1200 RPM or 60 percent of the speed rating.

As a general rule of thumb, we increase the clearance for operating speeds that exceed 70 percent of the speed rating, due to concerns over internal heat generation and thermal growth. In this case, we are at 60 percent of the speed rating, so normal clearance, ISO CO or the SNT standard C3, can be selected.

Observing the RIC chart on page 23, we find for 150 mm nominal bore at CO, the RIC will be 0.110 mm to 0.170 mm. We also note that the minimum recommended RIC (installed) is 0.056 mm.

Also from page 23, we note that we get an approximate reduction of RIC that is 80 percent of interference fit on a solid housing. Since we have a loose housing fit, there will be no RIC reduction from that fit.

Shaft fit RIC reductions and clearance:

For a 150 mm nominal bore at C3, the RIC will be 0.115 mm to 0.165 mm. Recalculating shaft fit RIC reduction and clearance:

$$\begin{aligned} \text{max. clearance} &= \text{max. RIC} - \text{min. fit reduction} \\ &= 0.165 - 0.034 = 0.131 \text{ mm} \end{aligned}$$

$$\begin{aligned} \text{min. clearance} &= \text{min. RIC} - \text{max. fit reduction} \\ &= 0.115 - 0.074 = 0.041 \text{ mm} \end{aligned}$$

Since the minimum mounted clearance is less than the minimum suggested RIC of 0.056 mm, the C3 RIC clearance limit needs to be reevaluated.

INSTALLATION

When using a tight fit inner ring, the method of assembly will depend on whether the bearing has a cylindrical or tapered bore.

CLEANLINESS

- Choose a clean environment, free from dust and moisture.
- The installer should make every effort to ensure cleanliness by use of protective screens and clean cloths.

PLAN THE WORK

- Know your plans in advance and have the necessary tools at hand. This reduces the amount of time for the job and decreases the chance for contamination to get into the bearing.

INSPECTION AND PREPARATION

- All component parts of the machine should be on hand and thoroughly cleaned before proceeding.
- Housings should be cleaned, including blowing out the oil holes.
- Do not use an air hose on bearings.
- If blind holes are used, insert a magnetic rod to remove metal chips that might be lodged there during fabrication.
- Shaft shoulders and spacer rings contacting the bearing should be square with the shaft axis.
- The shaft fillet must be small enough to clear the radius of the bearing.
- On original installations, all component parts should be checked against the detail specification prints for dimensional accuracy. Shaft and housing should be carefully checked for size and form (roundness, etc.).



WARNING

Failure to observe the following warnings could create a risk of death or serious injury.

Proper maintenance and handling practices are critical. Always follow installation instructions and maintain proper lubrication.

Never spin a bearing with compressed air. The components may be forcefully expelled.



CAUTION

Failure to follow these cautions could create a risk of injury.

Remove oil or rust inhibitor from parts before heating, to avoid fire and fumes.

SHAFT AND HOUSING FINISH

- Shaft surfaces on which the bearing will be mounted must be clean and free from nicks and burrs.
- For applications with stationary housing and rotating shaft, it is suggested that the bearing seat on the shaft be ground to 1.6 μm (65 $\mu\text{in.}$) Ra maximum.
- If it is impractical to use a ground finish, a machined finish of 3.2 μm (125 $\mu\text{in.}$) Ra is acceptable in many cases, but the amount of interference fit should be slightly increased.

INSTALLING CYLINDRICAL BORE BEARINGS

Heat expansion method

- Most applications require a tight interference fit on the shaft.
- Mounting is simplified by heating the bearing to expand it sufficiently to slide easily onto the shaft.
- Two methods of heating are commonly used:
 1. Tank of heated oil.
 - Accomplished by heating the bearing in a tank of oil that has a high flash point (see fig. 5).
 - The oil temperature should not be allowed to exceed 121° C (250° F). A temperature of 93° C (200° F) is sufficient for most applications.
 - The bearing should be heated for 20 or 30 minutes, or until it is expanded sufficiently to slide onto the shaft easily.
 - The oil bath is shown in fig. 5. The bearing should not be in direct contact with the heat source.
 - The usual arrangement is to have a screen several inches from the bottom of the tank. Small support blocks separate the bearing from the screen.
 - It is important to keep the bearing away from any localized high-heat source that may raise its temperature excessively, resulting in metallurgical property changes such as in ring hardness reduction.
 - Flame-type burners are commonly used. An automatic device for temperature control is desirable.
 - If safety regulations prevent the use of an open heated oil bath, a mixture of 15 percent soluble-oil water may be used. This mixture may be heated to a maximum of 93° C (200° F) without being flammable.

2. Induction heating.

- The induction heating process can be used for mounting bearings.
- Induction heating is rapid. Care must be taken to prevent bearing temperature from exceeding 93° C (200° F).
- Trial runs with the unit and bearing are usually necessary to obtain proper timing.
- Thermal crayons melted at predetermined temperatures or thermal gun can be used to check the bearing temperature.
- While the bearing is hot, it should be positioned squarely against the shoulder.
- Lockwashers and locknuts or clamping plates are then installed to hold the bearing against the shoulder of the shaft.
- As the bearing cools, the locknut or clamping plate should be tightened.
- For more information see the Timken Spherical Roller Bearing Catalog (order no. 10446), found on www.timken.com.

NOTE

Never use steam or hot water when cleaning the bearings because these methods can create rust or corrosion.

Never expose any surface of a bearing to the flame of a torch.

Do not heat bearing beyond 149° C (300° F).

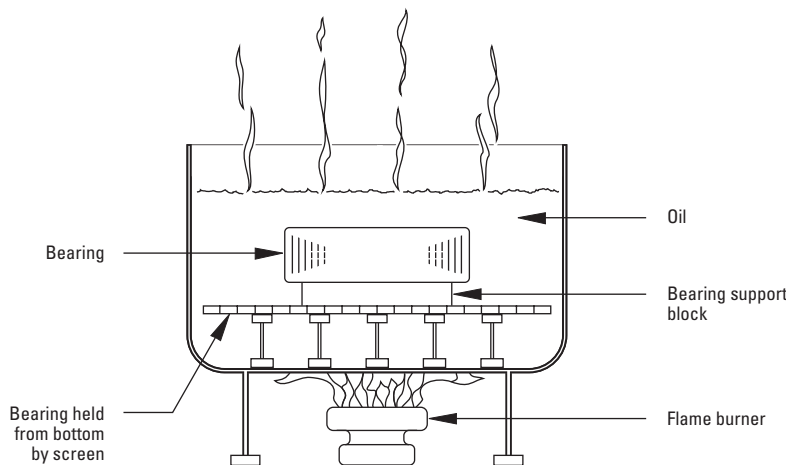

Fig. 5. Heat expansion method.

Arbor press method

- An alternate method of mounting, generally used only on smaller size bearings, is to press the bearing onto the shaft or into the housing. This can be done by using an arbor press and a mounting tube as shown in fig. 6.
- The tube should be made from soft steel with an inside diameter slightly larger than the shaft.
- The O.D. of the tube should not exceed the shaft backing diameter given in the Timken Spherical Roller Bearing Catalog (order no. 10446), found on www.timken.com.
- The tube should be faced square at both ends. It should be thoroughly clean inside and out, and long enough to clear the end of the shaft after the bearing is mounted.
- If the outer ring is being pressed into the housing, the O.D. of the mounting tube should be slightly smaller than the housing bore. The I.D. should not be less than the suggested housing backing diameter in the table of dimensions available in the Timken Spherical Roller Bearing Catalog (order no. 10446), found on www.timken.com.
- Coat the shaft with a light machine oil to reduce the force needed for a press fit.
- Carefully place the bearing on the shaft, making sure it is square with the shaft axis.
- Apply steady pressure from the arbor ram to drive the bearing firmly against the shoulder.

NOTE

Never attempt a press fit on a shaft by applying pressure to the outer ring or a press fit in a housing by applying pressure to the inner ring.

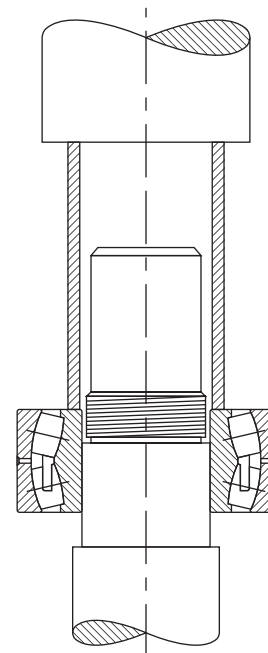

Fig. 6. Arbor press method.

Mounting tapered bore spherical roller bearings

- Use a feeler gage with the thinnest blade of 0.038 mm.
- Place the bearing in an upright position with the inner and outer ring faces parallel.
- Place thumbs on the inner ring bore and oscillate the inner ring the distance of two or three roller spacings.
- Position the individual roller assemblies so that a roller is at the top of the inner ring on both sides of the bearing.
- With the roller in the correct position, insert a thin blade of the feeler gage between the roller and the outer ring, as shown in fig. 7.
- Move the feeler gage carefully along the top roller between the roller and outer ring raceway. Repeat this procedure using thicker feeler gage blades until one is found that will not go through.
- The blade thickness that preceded the no-go blade is a measure of RIC before installation.
- Start the mounting procedure by lubricating the tapered shaft with a light coat of machine oil.
- Slide the bearing onto the shaft as far as it will go by hand.
- As the locknut is tightened, the interference fit builds up, resulting in expansion of the inner ring.
- Periodically measure to monitor the reduction in RIC.
- Continue the procedure until the proper amount of reduction is obtained. Do not exceed calculated amount of reduction.
- As a final check, make sure the remaining RIC equals or exceeds the minimum mounted clearance shown in table 5 on page 24.
- During mounting, the RIC should be checked at the unloaded roller. If this is at the bottom, make sure that the roller is raised to seat firmly at the inboard position of the inner ring.
- When the suggested amount of RIC reduction has been accomplished, the bearing is properly fitted.
- Complete the procedure by peening the lockwasher tang into the locknut slot or securing the lockplate.



Fig. 7. Measure RIC before installation.

SHAFT FITS FOR CYLINDRICAL BORE BEARINGS

This chart is a guideline for specifying shaft fits related to particular operating conditions. Please contact your Timken engineer for more information.

TABLE 6. RADIAL SPHERICAL ROLLER BEARING SHAFT FITS

Conditions	Examples	Shaft Dia.		Tolerance Symbol ⁽¹⁾	Remarks	
		mm in.				
Stationary inner ring load	The inner ring not to be easily displaced on the shaft	Wheel on non-rotating shaft	All diameters		g6	
		Tension pulleys and rope sheaves			h6	
Rotating inner ring load or indeterminate load direction	Light and variable loads $P \leq 0.07C$	Electrical apparatus, machine tools, pumps, ventilators, industrial trucks	over	incl.	k6	In very accurate applications, k5 and m5 are used instead of k6 and m6 respectively.
			18 0.7087	100 3.9370		
			100 3.9370	200 7.8740		
	18 0.7087	65 2.5590	m5			
	65 2.5590	100 3.9370	m6			
	100 3.9370	140 5.5118	n6			
	Normal and heavy loads $P > 0.07C$ $\leq 0.25C$	Applications in general, electrical motors, turbines, pumps, combustion engines, gear transmissions, woodworking machines	140 5.5118	280 11.0236	p6	
			280 11.0236	500 19.6850	r6	
			500 19.6850	and up	r7	
			18 0.7087	65 2.5590	m6	Bearings with greater clearance than normal must be used.
			65 2.5590	100 3.9370	n6	
			100 3.9370	140 5.5118	p6	
	140 5.5118	200 7.8740	r6			
	200 7.8740	500 19.6850	r7			
	BEARINGS WITH TAPERED BORE AND ADAPTER SLEEVE					
All loads	Applications in general	All diameters			See tables for Reduction of RIC on pages 23 and 24.	

⁽¹⁾For solid steel shaft. See tables on pages 30 through 35 for tolerance value.

NOTE: Tolerance and shaft diameters are shown in the table as variances from nominal bearing bore.

These charts are guidelines for specifying shaft and housing fits related to particular operating conditions in table 6 on page 29.

FITTING PRACTICE TABLES

TABLE 7. SPHERICAL ROLLER BEARINGS - SHAFT TOLERANCES (CLASSES g6, h5, h6, j5, j6, k5, k6, m5)

Bearing Bore			g6			h6			h5			j5		
Nominal (Max.)		Tolerance ⁽¹⁾	Shaft Dia.			Shaft Dia.			Shaft Dia.			Shaft Dia.		
Over	Incl.		Max.	Min.	Fit	Max.	Min.	Fit	Max.	Min.	Fit	Max.	Min.	Fit
mm	mm	mm	mm	mm	mm	mm	mm	mm	mm	mm	mm	mm	mm	mm
in.	in.	in.	in.	in.	in.	in.	in.	in.	in.	in.	in.	in.	in.	in.
30.000	50.000	-0.014	-0.009	-0.025	0.025L 0.003T	0.000	-0.016	0.012T	-	-	-	+0.006	-0.005	0.018T
1.1811	1.9685	-0.0006	-0.0004	-0.0010	0.0010L 0.0001T	0.0000	-0.0006	0.0006L 0.0005T				+0.0002	-0.0002	0.0002L 0.0007T
50.000	80.000	-0.015	-0.010	-0.029	0.029L 0.005T	0.000	-0.019	0.015T	-	-	-	+0.006	-0.007	0.021T
1.9685	3.1496	-0.0006	-0.0004	-0.0011	0.0011L 0.0002T	0.0000	-0.0007	0.0007L 0.0006T				+0.0002	-0.0003	0.0003L 0.0008T
80.000	120.000	-0.020	-0.012	-0.034	0.034L 0.008T	0.000	-0.022	0.020T	-	-	-	+0.006	-0.009	0.026T
3.1496	4.7244	-0.0008	-0.0005	-0.0013	0.0013L 0.0003T	0.0000	-0.0009	0.0009L 0.0008T				+0.0002	-0.0004	0.0004L 0.0010T
120.000	180.000	-0.025	-0.014	-0.039	0.039L 0.011T	0.000	-0.025	0.025T	-	-	-	+0.007	-0.011	0.032T
4.7244	7.0866	-0.0010	-0.0006	-0.0015	0.0015L 0.0004T	0.0000	-0.0010	0.0010L 0.0010T				+0.0003	-0.0004	0.0004L 0.0013T
180.000	200.000	-0.030	-0.015	-0.044	0.044T 0.015T	0.000	-0.029	0.030T	-	-	-	+0.007	-0.013	0.037T
7.0866	7.8740	-0.0012	-0.0006	-0.0017	0.0017L 0.0006T	0.0000	-0.0011	0.0011L 0.0012T				+0.0003	-0.0005	0.0005L 0.0015T
200.000	225.000	-0.030	-0.015	-0.044	0.044T 0.015T	0.000	-0.029	0.030T	-	-	-	+0.007	-0.013	0.037T
7.8740	8.8583	-0.0012	-0.0006	-0.0017	0.0017L 0.0006T	0.0000	-0.0011	0.0011L 0.0012T				+0.0003	-0.0005	0.0005L 0.0015T
225.000	250.000	-0.030	-0.015	-0.044	0.044T 0.015T	0.000	-0.029	0.030T	-	-	-	+0.007	-0.013	0.037T
8.8583	9.8425	-0.0012	-0.0006	-0.0017	0.0017L 0.0006T	0.0000	-0.0011	0.0011L 0.0012T				+0.0003	-0.0005	0.0005L 0.0015T
250.000	280.000	-0.035	-0.017	-0.049	0.049L 0.018T	0.000	-0.032	0.035T	-	-	-	+0.007	-0.016	0.042T
9.8425	11.0236	-0.0014	-0.0007	-0.0019	0.0019L 0.0007T	0.0000	-0.0013	0.0013L 0.0014T				+0.0003	-0.0006	0.0006L 0.0017T
280.000	315.000	-0.035	-0.017	-0.049	0.049L 0.018T	0.000	-0.032	0.035T	-	-	-	+0.007	-0.016	0.042T
11.0236	12.4016	-0.0014	-0.0007	-0.0019	0.0019L 0.0007T	0.0000	-0.0013	0.0013L 0.0014T				+0.0003	-0.0006	0.0006L 0.0017T
315.000	355.000	-0.040	-0.018	-0.054	0.054L 0.022T	0.000	-0.036	0.040T	-	-	-	+0.007	-0.018	0.047T
12.4016	13.9764	-0.0016	-0.0007	-0.0021	0.0021L 0.0009T	0.0000	-0.0014	0.0014L 0.0016T				+0.0003	-0.0007	0.0007L 0.0019T

⁽¹⁾Tolerance range is from +0 to value listed.

NOTE: Tolerance and shaft diameters are shown in the table as variances from nominal bearing bore.

These charts are guidelines for specifying shaft and housing fits related to particular operating conditions in table 6 on page 29.

j6			k5			k6			m5		
Shaft Dia.		Fit	Shaft Dia.		Fit	Shaft Dia.		Fit	Shaft Dia.		Fit
Max.	Min.		Max.	Min.		Max.	Min.		Max.	Min.	
mm	mm	mm	mm	mm	mm	mm	mm	mm	mm	mm	mm
in.	in.	in.	in.	in.	in.	in.	in.	in.	in.	in.	in.
		0.005L			0.002T			0.002T			0.009T
+0.011	-0.005	0.023T	+0.013	+0.002	0.025T	+0.018	+0.002	0.030T	+0.020	+0.009	0.032T
+0.0004	-0.0002	0.0002L	+0.0005	+0.0001	0.0001T	+0.0007	+0.0001	0.0001T	+0.0008	+0.0004	0.0004T
		0.00085T			0.0010T			0.0012T			0.00125T
		0.007L			0.002T			0.002T			0.011T
+0.012	-0.007	0.027T	+0.015	+0.002	0.030T	+0.021	+0.002	0.036T	+0.024	+0.011	0.039T
+0.0005	-0.0003	0.0003L	+0.0006	+0.0001	0.0001T	+0.0008	+0.0001	0.0001T	+0.0009	+0.0004	0.0004T
		0.0011T			0.0012T			0.0014T			0.0015T
		0.009L			0.003T			0.003T			0.013T
+0.013	-0.009	0.033T	+0.018	+0.003	0.038T	+0.025	+0.003	0.045T	+0.028	+0.013	0.048T
+0.0005	-0.0004	0.0004L	+0.0007	+0.0001	0.0001T	+0.0010	+0.0001	0.0001T	+0.0011	+0.0005	0.0005T
		0.0013T			0.0015T			0.0018T			0.0019T
		0.011L			0.003T			0.003T			0.015T
+0.014	-0.011	0.039T	+0.021	+0.003	0.046T	+0.028	+0.003	0.053T	+0.033	+0.015	0.058T
+0.0006	-0.0004	0.0004L	+0.0008	+0.0001	0.0001T	+0.0011	+0.0001	0.0001T	+0.0013	+0.0006	0.0006T
		0.0016T			0.0018T			0.0021T			0.0023T
		0.013L			0.004T						0.017T
+0.016	-0.013	0.046T	+0.024	+0.004	0.054T	-	-	-	+0.037	+0.017	0.067T
+0.0006	-0.0005	0.0005L	+0.0009	+0.0002	0.0002T				+0.0015	+0.0007	0.0007T
		0.0018T			0.0021T						0.0027T
		0.013L			0.004T						0.017T
+0.016	-0.013	0.046T	+0.024	+0.004	0.054T	-	-	-	+0.037	+0.017	0.067T
+0.0006	-0.0005	0.0005L	+0.0009	+0.0002	0.0002T				+0.0015	+0.0007	0.0007T
		0.0018T			0.0021T						0.0027T
		0.013L			0.004T						0.017T
+0.016	-0.013	0.046T	+0.024	+0.004	0.054T	-	-	-	+0.037	+0.017	0.067T
+0.0006	-0.0005	0.0005L	+0.0009	+0.0002	0.0002T				+0.0015	+0.0007	0.0007T
		0.0018T			0.0021T						0.0027T
		0.016L			0.004T						0.020T
+0.016	-0.016	0.051T	+0.027	+0.004	0.062T	-	-	-	+0.043	+0.020	0.078T
+0.0006	-0.0006	0.0006L	+0.0011	+0.0002	0.0002T				+0.0017	+0.0008	0.0008T
		0.0020T			0.0025T						0.0031T
		0.016L			0.004T						0.020T
+0.016	-0.016	0.051T	+0.027	+0.004	0.062T	-	-	-	+0.043	+0.020	0.078T
+0.0006	-0.0006	0.0006L	+0.0011	+0.0002	0.0002T				+0.0017	+0.0008	0.0008T
		0.0020T			0.0025T						0.0031T
		0.018L			0.004T						0.021T
+0.018	-0.018	0.058T	+0.029	+0.046	0.069T	-	-	-	+0.046	+0.021	0.086T
+0.0007	-0.0007	0.0007L	+0.0011	+0.0002	0.0002T				+0.0018	+0.0008	0.0008T
		0.0023T			0.0027T						0.0034T

⁽¹⁾Tolerance range is from +0 to value listed.

NOTE: Tolerance and shaft diameters are shown in the table as variances from nominal bearing bore.

Continued on next page.

These charts are guidelines for specifying shaft and housing fits related to particular operating conditions in table 6 on page 29.

TABLE 7. SPHERICAL ROLLER BEARINGS - SHAFT TOLERANCES (CLASSES g6, h5, h6, j5, j6, k5, k6, m5) – continued

Bearing Bore			g6			h6			h5			j5		
Nominal (Max.)		Tolerance ⁽¹⁾	Shaft Dia.			Shaft Dia.			Shaft Dia.			Shaft Dia.		
Over	Incl.		Max.	Min.	Fit	Max.	Min.	Fit	Max.	Min.	Fit	Max.	Min.	Fit
mm	mm	mm	mm	mm	mm	mm	mm	mm	mm	mm	mm	mm	mm	mm
in.	in.	in.	in.	in.	in.	in.	in.	in.	in.	in.	in.	in.	in.	in.
355.000	400.000	-0.040			0.054L			0.036L						0.018L
13.9764	15.7480	-0.0016	-0.018	-0.054	0.022T	0.000	-0.036	0.040T	–	–	–	+0.007	-0.018	0.047T
			-0.0007	-0.0021	0.0021L	0.0000	-0.0014	0.0014L				+0.0003	-0.0007	0.0007L
					0.0009T			0.0016T						0.0019T
					0.060L			0.040L						0.020L
400.000	450.000	-0.045	-0.020	-0.060	0.025T	0.000	-0.040	0.045T	–	–	–	+0.007	-0.020	0.052T
15.7480	17.7165	-0.0018	-0.0008	-0.0024	0.0024L	0.0000	-0.0016	0.0016L				+0.0003	-0.0008	0.0008L
					0.0010T			0.0018T						0.0021T
					0.060L			0.040L						0.020L
450.000	500.000	-0.045	-0.020	-0.060	0.025T	0.000	-0.040	0.045T	–	–	–	+0.007	-0.020	0.052T
17.7165	19.6850	-0.0018	-0.0008	-0.0024	0.0024L	0.0000	-0.0016	0.0016L				+0.0003	-0.0008	0.0008L
					0.0010T			0.0018T						0.0020T

⁽¹⁾Tolerance range is from +0 to value listed.

NOTE: Tolerance and shaft diameters are shown in the table as variances from nominal bearing bore.

These charts are guidelines for specifying shaft and housing fits related to particular operating conditions in table 6 on page 29.

j6			k5			k6			m5		
Shaft Dia.		Fit	Shaft Dia.		Fit	Shaft Dia.		Fit	Shaft Dia.		Fit
Max.	Min.		Max.	Min.		Max.	Min.		Max.	Min.	
mm	mm	mm	mm	mm	mm	mm	mm	mm	mm	mm	mm
in.	in.	in.	in.	in.	in.	in.	in.	in.	in.	in.	in.
		0.018L			0.004T						0.021T
+0.018	-0.018	0.058T	+0.029	+0.004	0.069T	—	—	—	+0.046	+0.021	0.086T
+0.0007	-0.0007	0.0007L	+0.0011	+0.0002	0.0002T				+0.0018	+0.0008	0.0008T
		0.0023T			0.0027T						0.0034T
		0.020L			0.005T						0.023T
+0.020	-0.020	0.065T	+0.032	+0.005	0.077T	—	—	—	+0.050	+0.023	0.095T
+0.0008	-0.0008	0.0008L	+0.0013	+0.0002	0.0002T				+0.0020	+0.0009	0.0009T
		0.0026T			0.0031T						0.0037T
		0.020L			0.005T						0.023T
+0.020	-0.020	0.065T	+0.032	+0.005	0.077T	—	—	—	+0.050	+0.023	0.095T
+0.0008	-0.0008	0.0008L	+0.0013	+0.0002	0.0002T				+0.0020	+0.0009	0.0009T
		0.0026T			0.0031T						0.0037T

⁽¹⁾Tolerance range is from +0 to value listed.

NOTE: Tolerance and shaft diameters are shown in the table as variances from nominal bearing bore.

These charts are guidelines for specifying shaft and housing fits related to particular operating conditions in table 6 on page 29.

TABLE 8. SPHERICAL ROLLER BEARINGS - SHAFT TOLERANCES (CLASSES m6, n6, p6, r6, r7)

Bearing Bore			m6			n6			p6			r6			r7		
Nominal (Max.)		Tolerance ⁽¹⁾	Shaft Dia.		Fit	Shaft Dia.		Fit	Shaft Dia.		Fit	Shaft Dia.		Fit	Shaft Dia.		Fit
Over	Incl.		Max.	Min.		Max.	Min.		Max.	Min.		Max.	Min.		Max.	Min.	
mm	mm	mm	mm	mm	mm	mm	mm	mm	mm	mm	mm	mm	mm	mm	mm	mm	mm
in.	in.	in.	in.	in.	in.	in.	in.	in.	in.	in.	in.	in.	in.	in.	in.	in.	in.
30.000	50.000	-0.014	+0.025	+0.009	0.037T												
1.1811	1.9685	-0.0006	+0.0010	+0.0004	0.0004T	-	-	-	-	-	-	-	-	-	-	-	-
					0.0145T												
50.000	80.000	-0.015	+0.030	+0.011	0.045T	+0.039	+0.020	0.054T									
1.9685	3.1496	-0.0006	+0.0012	+0.0004	0.0004T	+0.0015	+0.0008	0.0008T	-	-	-	-	-	-	-	-	-
					0.0018T			0.0021T									
80.000	120.000	-0.020	+0.035	+0.013	0.055T	+0.045	+0.023	0.065T	+0.059	+0.037	0.079T						
3.1496	4.7244	-0.0008	+0.0014	+0.0005	0.0005T	+0.0018	+0.0009	0.0009T	+0.0023	+0.0015	0.0015T	-	-	-	-	-	-
					0.0022T			0.0026T			0.0031T						
120.000	180.000	-0.025	+0.040	+0.015	0.065T	+0.052	+0.027	0.077T	+0.068	+0.043	0.093T	+0.090	+0.065	0.115T			
4.7244	7.0866	-0.0010	+0.0016	+0.0006	0.0006T	+0.0020	+0.0011	0.0011T	+0.0027	+0.0017	0.0017T	+0.0035	+0.0026	0.0026T	-	-	-
					0.0026T			0.0030T			0.0037T			0.0045T			
180.000	200.000	-0.030	+0.046	+0.017	0.076T	+0.060	+0.031	0.090T	+0.079	+0.050	0.109T	+0.106	+0.077	0.136T			
7.0866	7.8740	-0.0012	+0.0018	+0.0007	0.0007T	+0.0024	+0.0012	0.0012L	+0.0031	+0.0020	0.0020T	+0.0042	+0.0030	0.0030T	-	-	-
					0.0030T			0.0036T			0.0043T			0.0054T			
200.000	225.000	-0.030	+0.046	+0.017	0.076T	+0.060	+0.031	0.090T	+0.079	+0.050	0.109T	+0.109	+0.080	0.139T	+0.126	+0.080	0.156T
7.8740	8.8583	-0.0012	+0.0018	+0.0007	0.0007T	+0.0024	+0.0012	0.0012L	+0.0031	+0.0020	0.0020T	+0.0043	+0.0031	0.0031T	+0.0050	+0.0031	0.0031T
					0.0030T			0.0036T			0.0043T			0.0055T			0.0062T
225.000	250.000	-0.030	+0.046	+0.017	0.076T	+0.060	+0.031	0.090T	+0.079	+0.050	0.109T	+0.113	+0.084	0.143T	+0.130	+0.084	0.160T
8.8583	9.8425	-0.0012	+0.0018	+0.0007	0.0007T	+0.0024	+0.0012	0.0012L	+0.0031	+0.0020	0.0020T	+0.0044	+0.0033	0.0033T	+0.0051	+0.0033	0.0033T
					0.0030T			0.0036T			0.0043T			0.0056T			0.0063T
250.000	280.000	-0.035	+0.052	+0.020	0.087T	+0.066	+0.034	0.101T	+0.088	+0.056	0.123T	+0.126	+0.094	0.161T	+0.146	+0.094	0.181T
9.8425	11.0236	-0.0014	+0.0020	+0.0008	0.0008T	+0.0026	+0.0013	0.0013T	+0.0035	+0.0022	0.0022T	+0.0050	+0.0037	0.0037T	+0.0057	+0.0037	0.0037T
					0.0034T			0.0040T			0.0049T			0.0064T			0.0071T
280.000	315.000	-0.035	+0.052	+0.020	0.087T	+0.066	+0.034	0.101T	+0.088	+0.056	0.123T	+0.130	+0.098	0.165T	+0.150	+0.098	0.185T
11.0236	12.4016	-0.0014	+0.0020	+0.0008	0.0008T	+0.0026	+0.0013	0.0013T	+0.0035	+0.0022	0.0022T	+0.0051	+0.0039	0.0039T	+0.0059	+0.0039	0.0039T
					0.0034T			0.0040T			0.0049T			0.0065T			0.0073T
315.000	355.000	-0.040	+0.057	+0.021	0.097T	+0.073	+0.037	0.113T	+0.098	+0.062	0.138T	+0.144	+0.108	0.184T	+0.165	+0.108	0.205T
12.4016	13.9764	-0.0016	+0.0022	+0.0008	0.0008T	+0.0029	+0.0015	0.0015T	+0.0039	+0.0024	0.0024T	+0.0057	+0.0043	0.0043T	+0.0065	+0.0043	0.0043T
					0.0038T			0.0045T			0.0055T			0.0073T			0.0081T

⁽¹⁾Tolerance range is from +0 to value listed.

NOTE: Tolerance and shaft diameters are shown in the table as variances from nominal bearing bore.

Continued on next page.

These charts are guidelines for specifying shaft and housing fits related to particular operating conditions in table 6 on page 29.

Continued from previous page.

Bearing Bore			m6			n6			p6			r6			r7		
Nominal (Max.)		Tolerance ⁽¹⁾	Shaft Dia.			Shaft Dia.			Shaft Dia.			Shaft Dia.			Shaft Dia.		
Over	Incl.		Max.	Min.	Fit	Max.	Min.	Fit	Max.	Min.	Fit	Max.	Min.	Fit	Max.	Min.	Fit
mm	mm	mm	mm	mm	mm	mm	mm	mm	mm	mm	mm	mm	mm	mm	mm	mm	mm
in.	in.	in.	in.	in.	in.	in.	in.	in.	in.	in.	in.	in.	in.	in.	in.	in.	in.
355.000	400.000	-0.040	-	-	-	0.037T			0.062T			0.114T			0.114T		
		13.9764				15.7480	-0.0016	+0.073	+0.037	0.113T	+0.098	+0.062	0.138T	+0.150	+0.114	0.190T	+0.171
						+0.0029	+0.0015	0.0015T	+0.0039	+0.0024	0.0024T	+0.0059	+0.0045	0.0045T	+0.0067	+0.0045	0.0045T
								0.0045T			0.0055T			0.0075T			0.0083T
400.000	450.000	-0.045	-	-	-	0.040T			0.068T			0.126T			0.126T		
		15.7480				17.7165	-0.0018	+0.080	+0.040	0.125T	+0.108	+0.068	0.153T	+0.166	+0.126	0.211T	+0.189
						+0.0031	+0.0016	0.0016T	+0.0043	+0.0027	0.0027T	+0.0065	+0.0050	0.0050T	+0.0074	+0.0050	0.0050T
								0.0049T			0.0061T			0.0083T			0.0092T
450.000	500.000	-0.045	-	-	-	0.040T			0.068T			0.132T			0.132T		
		17.7165				19.6850	-0.0018	+0.080	+0.040	0.125T	+0.108	+0.068	0.153T	+0.172	+0.132	0.217T	+0.195
						+0.0031	+0.0016	0.0016T	+0.0043	+0.0027	0.0027T	+0.0068	+0.0052	0.0052T	+0.0077	+0.0052	0.0052T
								0.0049T			0.0061T			0.0086T			0.0095T

⁽¹⁾Tolerance range is from +0 to value listed.

NOTE: Tolerance and shaft diameters are shown in the table as variances from nominal bearing bore.

LUBRICATION

To help maintain a bearing’s antifriction characteristics, lubrication is needed to:

- Minimize rolling resistance caused by deformation of the rolling elements and raceway under load by separating the mating surfaces.
- Minimize sliding friction occurring between rolling elements, raceways and cage.
- Transfer heat (with oil lubrication).
- Protect from corrosion and, with grease lubrication, from contaminant ingress.

Lubrication	38
General-Purpose Industrial Grease	45



LUBRICATION

The wide range of bearing types and operating conditions precludes any simple, all-inclusive statement or guideline allowing the selection of the proper lubricant. At the design level, the first consideration is whether oil or grease is best for the particular operation. The advantages of oil and grease are outlined in the table below. When heat must be carried away from the bearing, oil must be used. It is typically preferred for very high-speed applications. **Timken® SNT housings and seal systems are specifically designed for grease lubrication. If an application requires oil lubrication, contact your Timken engineer for assistance.**

TABLE 9. ADVANTAGES OF OIL AND GREASE

Oil	Grease
Carries heat away from the bearings	Simplifies seal design and acts as a sealant
Carries away moisture and particulate matter	Permits prelubrication of sealed or shielded bearings
Easily controlled lubrication	Generally requires less frequent lubrication

European REACH compliance

Timken-branded lubricants, greases and similar products sold in stand-alone containers or delivery systems are subject to the European REACH (Registration, Evaluation, Authorization and Restriction of Chemicals) directive. For import into the European Union, Timken can sell and provide only those lubricants and greases that are registered with ECHA (European Chemical Agency). For further information, please contact your Timken engineer.

GREASE LUBRICATION

Grease lubrication is generally applicable to low-to-moderate speed applications that have operating temperatures within the limits of the grease. There is no universal antifriction bearing grease. Each grease has limiting properties and characteristics.

Greases consist of a base oil, a thickening agent and additives. Conventionally, bearing greases have consisted of petroleum base oils thickened to the desired consistency by some form of metallic soap. More recently synthetic base oils have been used with organic and inorganic thickeners. Table 10 summarizes the composition of typical lubricating greases.

TABLE 10. COMPOSITION OF GREASES

Base Oil	+	Thickening Agents	+	Additives	=	Lubricating Grease
Mineral oil		Soaps and complex soaps		Rust inhibitors		
Synthetic hydrocarbon		lithium, aluminum, barium, calcium		Dyes		
Esters		Non-Soap (inorganic)		Tactifiers		
Perfluorinated oil		microgel (clay), carbon black,		Metal deactivates		
Silicone		silica-gel, PTFE		Oxidation inhibitors		
		Non-Soap (organic)		Anti-wear EP		
		Urea compounds				

Calcium- and aluminum-based greases have excellent water resistance and are used in industrial applications where water ingress is an issue. Lithium-based greases are multi-purpose and are used in industrial applications and wheel bearings.

Synthetic base oils such as esters, organic esters and silicones used with conventional thickeners and additives typically have higher maximum operating temperatures than petroleum-based greases. Synthetic greases can be designed to operate in temperatures from -73° C (-100° F) to 288° C (550° F).

In table 11 are the general characteristics of common thickeners used with petroleum base oils.

Use of the thickeners in table 11 with synthetic hydrocarbon or ester base oils increases the maximum operating temperature by approximately 10° C (18° F).

TABLE 11. GENERAL CHARACTERISTICS OF THICKENERS USED WITH PETROLEUM-BASED OILS

Thickener	Typical Dropping Point		Maximum Temperature		Typical Water Resistance
	°C	°F	°C	°F	
Lithium soap	193	380	121	250	Good
Lithium complex	260+	500+	149	300	Good
Aluminum complex	249	480	149	300	Excellent
Calcium sulfonate	299	570	177	350	Excellent
Polyurea	260	500	149	300	Good

Using polyurea as a thickener for lubricating fluids is one of the most significant lubrication developments in more than 30 years. Polyurea grease performance is outstanding in a wide range of bearing applications.

BASE OILS

Base oils are classified as either petroleum types (refined from crude oil) or synthetic types (produced by chemical synthesis).

Petroleum oils

Petroleum oils are made from a petroleum hydrocarbon derived from crude oil, with additives to improve certain properties. Greases with petroleum oils can be used in most general industrial bearing applications and many specialty applications with moderate operating temperatures.

Synthetic oils

Synthetic oils cover a broad range or categories and include polyalphaolefins, silicones, polyglycols and various esters. In general, synthetic oils are less prone to oxidation and perform more efficiently than petroleum oils at extreme hot or cold temperatures. Physical properties, such as pressure-viscosity coefficients, tend to vary between oil types. Use caution when making oil selections.

The polyalphaolefins (PAO) have a hydrocarbon chemistry that parallels petroleum oil both in chemical structures and pressure-viscosity coefficients. Therefore, PAO oil is mostly used in the oil-lubricated applications of bearings when severe temperature environments (hot and cold) are encountered or when extended lubricant life is required.

The silicone, ester and polyglycol oils have an oxygen-based chemistry that is structurally quite different from petroleum oils and PAO oils. This difference has a profound effect on its physical properties where pressure-viscosity coefficients can be lower compared to mineral and PAO oils. This means that these types of synthetic oils may actually generate a smaller elastohydrodynamic (EHD) film thickness than a mineral or PAO oil of equal viscosity at operating temperature. Reductions in bearing fatigue life and increases in bearing wear could result from this reduction of lubricant film thickness.

Viscosity

The selection of oil viscosity for any bearing application requires consideration of several factors: load, speed, bearing setting, type of oil and environmental factors. Since oil viscosity varies inversely with temperature, a viscosity value must always be stated with the temperature at which it was determined. High-viscosity oil is used for low-speed or high-ambient-temperature applications. Low-viscosity oil is used for high-speed or low-ambient-temperature applications.

There are several classifications of oils based on viscosity grades. The most familiar are the Society of Automotive Engineers (SAE) classifications for automotive engine and gear oils. The American Society for Testing and Materials (ASTM) and the International Organization for Standardization (ISO) have adopted standard viscosity grades for industrial fluids. Fig. 8 shows the viscosity comparisons of ISO/ASTM with SAE classification systems at 40° C (104° F).

VISCOSITY CLASSIFICATION COMPARISON

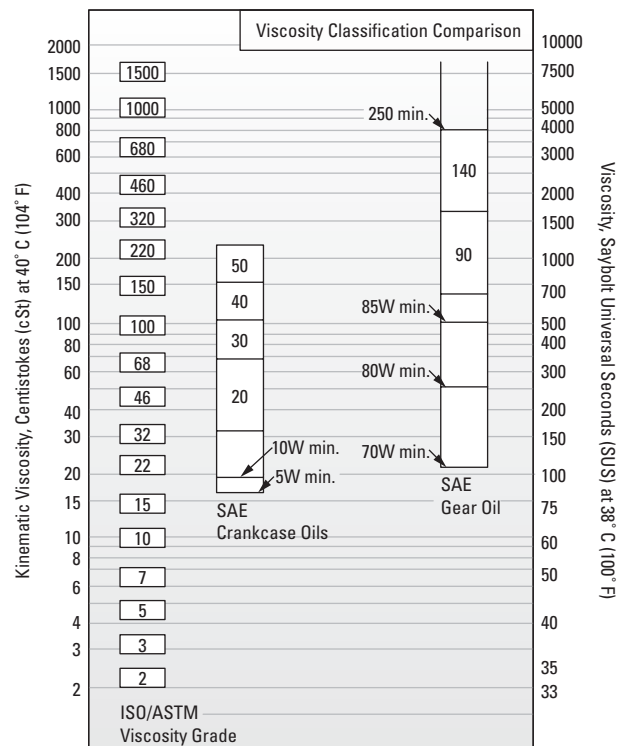

Fig. 8. Comparison between ISO/ASTM grades (ISO 3448/ASTM D2442) and SAE grades (SAE J 300-80 for crankcase oils, SAE J 306-81 for axle and manual transmission oils).

⚠ WARNING

Failure to observe the following warnings could create a risk of death or serious injury.

Proper maintenance and handling practices are critical. Always follow installation instructions and maintain proper lubrication.

The ASTM/ISO viscosity grade system for industrial oils is depicted in fig. 9 below.

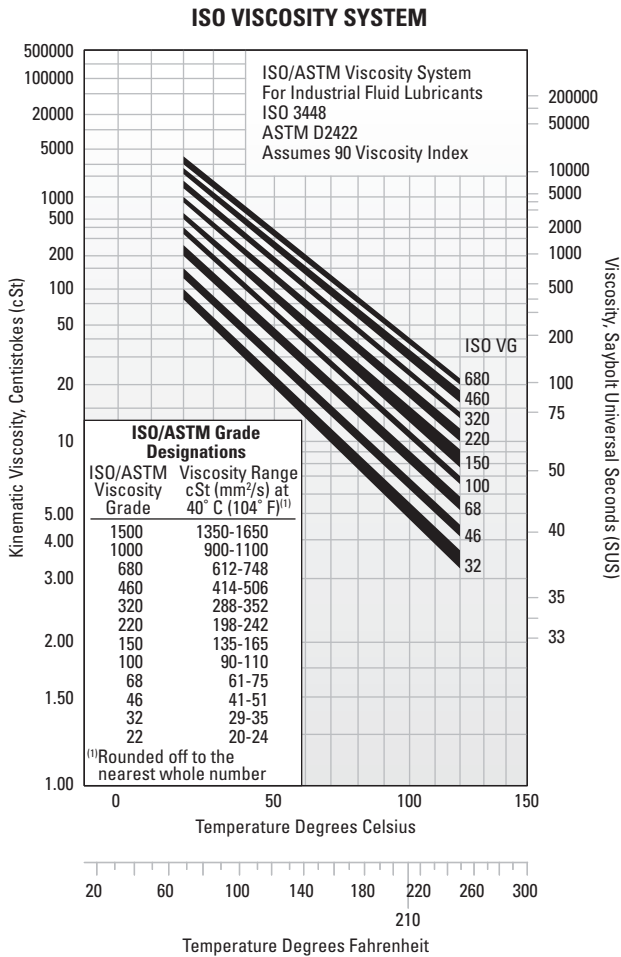

Fig. 9. Viscosity grade system for industrial oils.

CONSISTENCY

Greases may vary in consistency from semi-fluids that are hardly thicker than a viscous oil to solid grades almost as hard as a soft wood.

Consistency is measured by a penetrometer in which a standard weighted cone is dropped into the grease. The distance the cone penetrates (measured in tenths of a millimeter in a specific time) is the penetration number.

The National Lubricating Grease Institute (NLGI) classification of grease consistency is shown in table 12 below.

TABLE 12. NLGI CLASSIFICATIONS

NLGI Grease Grades	Penetration No.
0	355-385
1	310-340
2	265-295
3	220-250
4	175-205
5	130-160
6	85-115

Grease consistency is not fixed, it normally becomes softer when sheared or worked. In the laboratory, this working is accomplished by forcing a perforated plate up and down through a closed container of grease. This working does not compare with the violent shearing action that takes place in a bearing and does not necessarily correlate with actual performance.

LOW TEMPERATURES

Starting torque in a grease-lubricated bearing at low temperatures can be critical. Some greases may function adequately as long as the bearing is operating, but resistance to initial movement may be excessive. In certain smaller machines, starting may be impossible when very cold. Under such operating circumstances, greases containing low-temperature characteristic oils are generally required.

If the operating temperature range is wide, synthetic greases offer advantages. Synthetic greases are available to provide very low starting and running torque at temperatures as low as -73°C (-100°F). In certain instances, these greases perform better in this respect than oil.

An important point concerning lubricating greases is that the starting torque is not necessarily a function of the consistency or the channel properties of the grease. Starting torque is more a function of the individual rheological properties of a particular grease and is best evaluated by application experience.

HIGH TEMPERATURES

The high temperature limit for lubricating greases is generally a function of the thermal and oxidation stability of the fluid and the effectiveness of the oxidation inhibitors. Grease temperature ranges are defined by both the dropping point of the grease thickener and composition of the base oil. Table 13 shows the temperature ranges of various base oils used in grease formulations.

A rule of thumb, developed from years of testing grease-lubricated bearings, indicates that grease life is halved for every 10°C (18°F) increase in temperature. For example, if a particular grease provides 2000 hours of life at 90°C (194°F), by raising the temperature to 100°C (212°F), reduction in life to approximately 1000 hours would result. On the other hand, 4000 hours could be expected by lowering the temperature to 80°C (176°F).

Thermal stability, oxidation resistance and temperature limitations must be considered when selecting greases for high-temperature applications. In non-relubricatable applications, highly refined mineral oils or chemically stable synthetic fluids are required as the oil component of greases for operation at temperatures above 121°C (250°F).

TABLE 13. TEMPERATURE RANGES FOR BASE OILS USED IN LUBRICATING GREASES

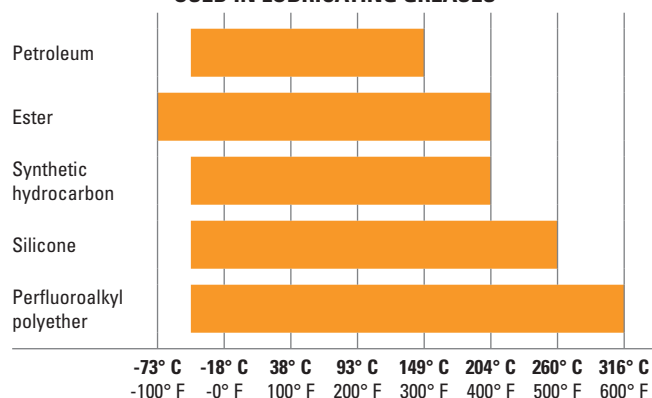

CONTAMINATION

Abrasive Particles

When roller bearings operate in a clean environment, the primary cause of damage is the eventual fatigue of the surfaces where rolling contact occurs. However, when particle contamination enters the bearing system, it is likely to cause damage such as bruising, which can shorten bearing life.

When dirt from the environment or metallic wear debris from some component in the application are allowed to contaminate the lubricant, wear can become the predominant cause of bearing damage. If bearing wear becomes significant, changes will occur to critical bearing dimensions that could adversely affect machine operation.

Bearings operating in a contaminated lubricant exhibit a higher initial rate of wear than those running in an uncontaminated lubricant. With no further contaminant ingress, this wear rate quickly diminishes. The contamination particles are reduced in size as they pass through the bearing contact area during normal operation.

Water

Water and moisture can be particularly conducive to bearing damage. Lubricating greases may provide a measure of protection from this contamination. Certain greases, such as calcium and aluminum-complex, are highly water-resistant.

Sodium-soap greases are water-soluble and should not be used in applications involving water.

Either dissolved or suspended water in lubricating oils can exert a detrimental influence on bearing fatigue life. Water can cause bearing etching that also can reduce bearing fatigue life. The exact mechanism by which water lowers fatigue life is not fully understood. It has been suggested that water enters micro-cracks in the bearing rings that are caused by repeated stress cycles. This leads to corrosion and hydrogen embrittlement in the micro-cracks, reducing the time required for these cracks to propagate to an unacceptable-sized spall.

Water-based fluids, such as water glycol and invert emulsions, also have shown a reduction in bearing fatigue life. Although water from these sources is not the same as contamination, the results support the previous discussion concerning water-contaminated lubricants.

GREASE SELECTION

The successful use of bearing grease depends on the physical and chemical properties of the lubricant as well as application and environmental conditions. Because the choice of grease for a particular bearing under certain service conditions is often difficult to make, you should consult with your lubricant supplier or equipment maker for specific questions about lubrication requirements for your application. You also can contact your Timken engineer for general lubrication guidelines for any application.

Grease must be carefully selected with regard to its consistency at operating temperature. It should not exhibit thickening, separation of oil, acid formation or hardening to any marked degree. It should be smooth, non-fibrous and entirely free from chemically active ingredients. Its dropping point should be considerably higher than the operating temperature.

PERFORMANCE ENHANCING GREASE ADDITIVES

Greases can be enhanced with a variety of base oil and soap additive packages that improve the performance of the grease and extend the life of the bearing the grease is lubricating. These additive packages can include agents which:

- inhibit oxidation, rust and corrosion
- resist water immersion and washout
- provide anti-wear protection
- allow extreme pressure from extraordinary loading

Timken® application-specific lubricants were developed by leveraging our knowledge of tribology and antifriction bearings, and how these two elements affect overall system performance. Timken lubricants help bearings and related components operate effectively in demanding industrial operations. High-temperature, anti-wear and water-resistant additives offer superior protection in challenging environments. Table 14 provides an overview of the Timken greases available for general applications. Contact your Timken engineer for a more detailed publication on Timken lubrication solutions.

TABLE 14. GREASE LUBRICATION SELECTION GUIDE

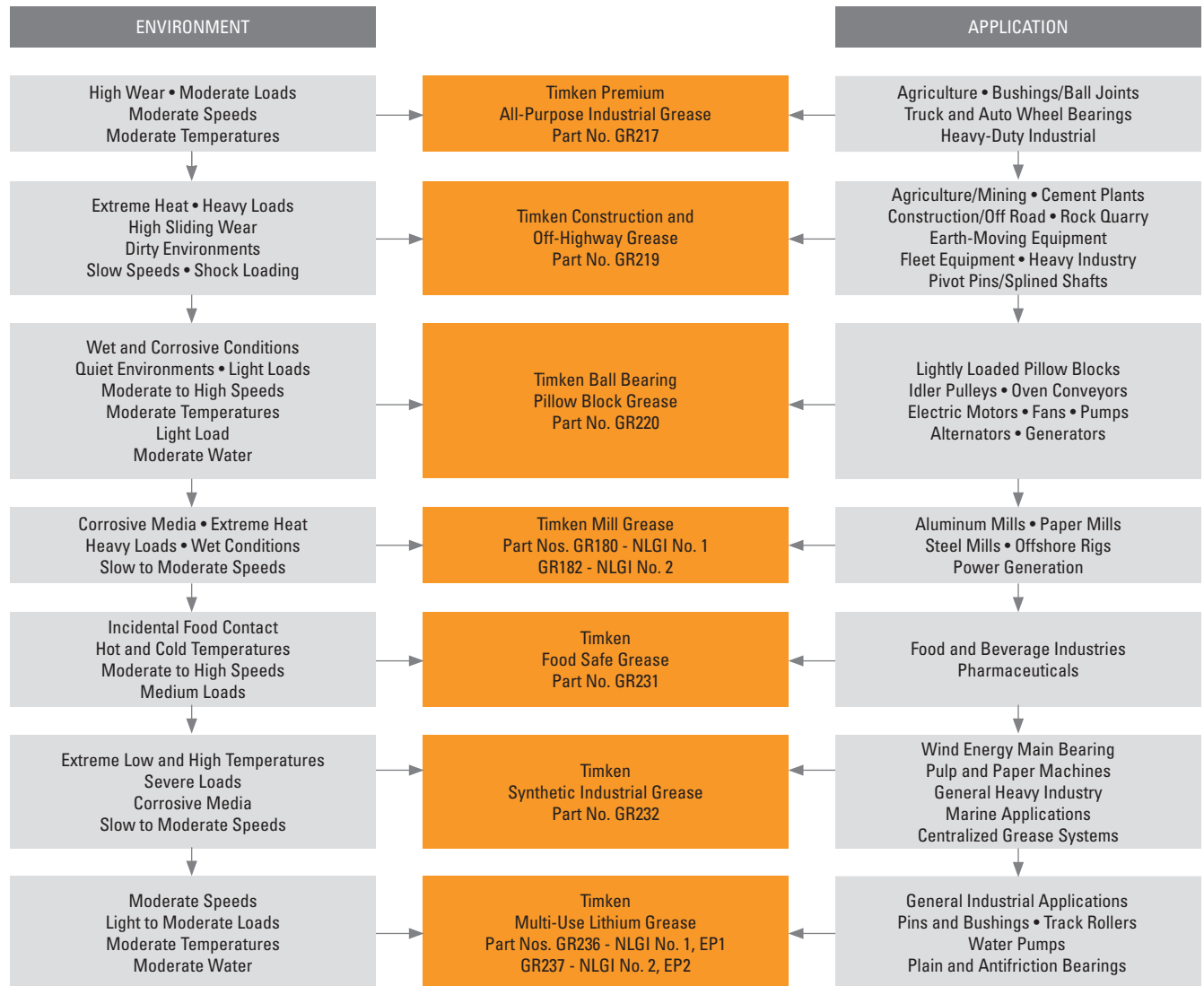

This selection guide is not intended to replace the specifications by the equipment builder, who is responsible for its performance.

Many bearing applications require lubricants with special properties or lubricants formulated specifically for certain environments, such as:

- Friction oxidation (fretting corrosion).
- Chemical and solvent resistance.
- Food handling.

For assistance with these or other areas requiring special lubricants, consult your Timken engineer.

GREASE USE GUIDELINES

It is important to use the proper amount of grease in the application. In typical industrial applications, the bearing cavity should be kept approximately one-third to one-half full. Less grease may result in the bearing being starved for lubrication. More grease may result in churning. Both conditions may result in excessive heat generation. As the grease temperature rises, viscosity decreases and the grease becomes thinner. This can reduce the lubricating effect and increase leakage of the grease from the bearing. It also may cause the grease components to separate, leading to a general breakdown of the lubricant properties. As the grease breaks down, bearing torque increases. In the case of excess grease resulting in churning, torque may also increase due to the resistance caused by the grease.

For best results, there should be ample space in the housing to allow room for excess grease to be displaced. However, it is equally important that the grease be retained all around the bearing. If a large void exists between the bearings, grease closures should be used to prevent the grease from leaving the bearing area.

Frictional torque is influenced by the quantity and the quality of lubricant present. Excessive quantities of grease causes churning. The adverse effects of churn are accelerated with increases in operating speed. The churn results in excessive temperatures, separation of the grease components, and breakdown in lubrication values. In normal-speed applications, the housings should be kept approximately one-third to one-half full.

Only in low-speed applications may the housing be entirely filled with grease. This method of lubrication is a safeguard against the entry of foreign matter, where sealing provisions are inadequate for exclusion of contaminants or moisture.

During periods of non-operation, completely filling the housings with grease can provide additional protection to the bearing surfaces. Prior to restarting operation, remove the excess grease and restore the proper level.

Applications using grease lubrication should have a grease fitting and a vent at opposite ends of the housing near the top. A drain plug should be located near the bottom of the housing to allow the grease to purge as needed.

Bearings should be relubricated at regular intervals to help prevent damage. Relubrication intervals are difficult to determine. If plant practice or experience with other applications is not available, consult your lubricant supplier.



Fig. 10. Grease can easily be packed by hand.



Fig. 11. Mechanical grease packer.

Timken offers a range of lubricants to help bearings and related components operate effectively in demanding industrial operations. High-temperature, anti-wear and water-resistant additives offer greater protection in challenging environments. Timken also offers a line of single- and multi-point lubricators to simplify grease delivery.

Grease application methods

Grease, in general, is easier to use than oil in industrial bearing applications. Most bearings that are initially packed with grease require periodic relubrication to operate efficiently.

Grease should be packed into the bearing so that it gets between the rolling elements and coats raceway surfaces.

Grease can be easily packed into small- and medium-size bearings by hand (fig. 10). In shops where bearings are frequently regreased, a mechanical grease packer that forces grease through the bearing under pressure may be appropriate (fig. 11). Regardless of the method, after packing the internal areas of the bearing, a small amount of grease also should be smeared on the outside of the rollers.

The two primary considerations that can effect the relubrication cycle are operating temperature and sealing efficiency. High-operating-temperature applications generally require more frequent regreasing. The less efficient the seals, the greater the grease loss and the more frequently grease must be added.

Grease should be added any time the amount in the bearing falls below the desired amount. The grease should be replaced when its lubrication properties have been reduced through contamination, high temperature, water, oxidation or any other factors. It is also important to follow suggested practice for seal lubrication. Mounting instructions shown starting on page 55 indicated appropriate methods based on seal and housing construction.

GENERAL-PURPOSE INDUSTRIAL GREASE

Polyurea and lithium-based greases are typical of greases that can be used to lubricate many Timken bearing applications in all types of standard equipment. Polyurea and lithium-based greases are normally preferred for general-purpose bearing lubrication and are advantageous in high moisture applications. Both greases have good water-resistant characteristics.

Special consideration should be given to applications where speed, load, temperature or environmental conditions are extreme. For temperature ranges of standard greases see table 13.

Lithium greases, lithium complex greases, or calcium sulfonate thickened grease are suitable for most centralized, single-point, or manually lubricated product. These greases should be smooth, homogeneous and uniform, premium-quality product composed of mineral or synthetic oil, a thickener and appropriate inhibitors (see table 15).

TABLE 15. SUGGESTED LITHIUM SOAP, LITHIUM COMPLEX AND CALCIUM SULFONATE GREASE PROPERTIES

Thickener type	Lithium Complex, or equivalent
Consistency	NLGI No.1 or No. 2
Additives	Anti-wear, corrosion and oxidation inhibitors
Base oil	Mineral oil or synthetic
Viscosity at 40° C	ISO VG 150-220
Viscosity index	80 min.
Pour point	-18° C (0° F) max.

They should not contain materials that are corrosive or abrasive to bearings or seals. The grease should have excellent mechanical and chemical stability. The grease should contain inhibitors to provide long-term protection against oxidation in high-performance applications and protect the bearings from corrosion in the presence of moisture. The suggested base oil viscosity covers a fairly wide range. Lower viscosity products should be used in high-speed and/or lightly loaded applications to minimize heat generation and torque. Higher viscosity products should be used in moderate- to low-speed applications and under heavy loads to maximize lubricant film thickness.

Speed ratings are listed for each size/class part number in the Timken Spherical Roller Bearing Catalog (order no. 10446) on pages 59–88. When application speeds exceed 70 percent of grease speed rating, consider increasing RIC by one ISO clearance range (CNormal to C3). Table 16 is provided as a reference for typical grease thickener compatibilities. For general industrial applications, consider a grease that is NLGI No. 1 or No. 2, with a ISO 150 to 220 viscosity grade.

NOTE

Mixing greases can result in improper bearing lubrication. Always follow the specific lubrication instructions of your equipment supplier.

Consult your lubricant supplier for further information for your specific requirement.

TABLE 16. GREASE COMPATIBILITY CHART

	Al Complex	Ba Complex	Ca Stearate	Ca 12 Hydroxy	Ca Complex	Ca Sulfonate	Non-Soap Clay	Li Stearate	Li 12 Hydroxy	Li Complex	Polyurea	Polyurea S S
Aluminum Complex	Best Choice	Compatible	Incompatible	Compatible	Incompatible	Borderline	Incompatible	Incompatible	Incompatible	Compatible	Incompatible	Compatible
Timken Food Safe	Best Choice	Compatible	Incompatible	Compatible	Incompatible	Borderline	Incompatible	Incompatible	Incompatible	Compatible	Incompatible	Compatible
Barium Complex	Incompatible	Best Choice	Incompatible	Compatible	Incompatible	Compatible	Incompatible	Incompatible	Incompatible	Incompatible	Incompatible	Borderline
Calcium Stearate	Incompatible	Incompatible	Best Choice	Compatible	Incompatible	Compatible	Compatible	Compatible	Borderline	Compatible	Incompatible	Compatible
Calcium 12 Hydroxy	Compatible	Compatible	Compatible	Best Choice	Borderline	Borderline	Compatible	Compatible	Compatible	Compatible	Incompatible	Compatible
Calcium Complex	Incompatible	Incompatible	Incompatible	Borderline	Best Choice	Incompatible	Incompatible	Incompatible	Incompatible	Compatible	Compatible	Compatible
Calcium Sulfonate	Borderline	Compatible	Compatible	Borderline	Incompatible	Best Choice	Incompatible	Borderline	Borderline	Compatible	Incompatible	Compatible
Timken Premium Mill Timken Heavy-Duty Moly	Borderline	Compatible	Compatible	Borderline	Incompatible	Best Choice	Incompatible	Borderline	Borderline	Compatible	Incompatible	Compatible
Clay Non-Soap	Incompatible	Incompatible	Compatible	Compatible	Incompatible	Incompatible	Best Choice	Incompatible	Incompatible	Incompatible	Incompatible	Borderline
Lithium Stearate	Incompatible	Incompatible	Compatible	Compatible	Incompatible	Borderline	Incompatible	Best Choice	Compatible	Compatible	Incompatible	Compatible
Lithium 12 Hydroxy	Incompatible	Incompatible	Borderline	Compatible	Incompatible	Borderline	Incompatible	Compatible	Best Choice	Compatible	Incompatible	Compatible
Lithium Complex	Compatible	Incompatible	Compatible	Compatible	Compatible	Compatible	Incompatible	Compatible	Compatible	Best Choice	Incompatible	Compatible
Polyurea Conventional	Incompatible	Incompatible	Incompatible	Incompatible	Compatible	Incompatible	Incompatible	Incompatible	Incompatible	Incompatible	Best Choice	Compatible
Polyurea Shear Stable	Compatible	Borderline	Compatible	Compatible	Compatible	Compatible	Borderline	Compatible	Compatible	Compatible	Compatible	Best Choice
Timken Multi-Use	Incompatible	Incompatible	Borderline	Compatible	Incompatible	Borderline	Incompatible	Compatible	Best Choice	Compatible	Incompatible	Compatible
Timken All -Purpose Timken Synthetic	Compatible	Incompatible	Compatible	Compatible	Compatible	Compatible	Incompatible	Compatible	Compatible	Best Choice	Incompatible	Compatible
Timken Pillow Block	Compatible	Borderline	Compatible	Compatible	Compatible	Compatible	Borderline	Compatible	Compatible	Compatible	Compatible	Best Choice

APPLICATION CONSIDERATIONS

For higher speed applications (operating at 70 percent of the grease speed rating or more), a lighter base oil viscosity (ISO 100–150) can be considered. Conversely, for lower speed applications, a grease with a heavier base oil viscosity (ISO 320–460) can be considered. For lower speed applications operating at colder start-up temperatures ($<-18^{\circ}\text{C}$ [0°F]), consider a softer grease (NLGI grade 1) with an approved EP additive. The lighter grade will allow more grease flow into the bearing contact area and the EP additive will reduce wear during start-up. An ISO 460 base oil viscosity also can be considered.

When lower speed applications operate at higher temperatures ($>149^{\circ}\text{C}$ [300°F]), consult your Timken engineer.

SNT SPHERICAL ROLLER BEARING PLUMMER BLOCKS PRODUCT DATA TABLES

Spherical roller bearing plummer blocks combine rugged cast iron, ductile iron or steel housings with high-capacity bearings to meet the toughest demands of industry. Each plummer block contains an advanced-design spherical roller bearing with improved geometry and raceway finish for maximized load capacity and service life. Integrated housing and bearing features enhance unit lubrication characteristics. Multiple sealing options protect against contamination.

Nomenclature.....50
 Introduction.....51
 Design and Construction51
 Mounting.....52
 SNT Lubrication53
 Seals.....53
 Load Ratings and Life54
 Installation Guides.....55
 Two-Bolt SNT Housings For Tapered Bore Bearings60
 Four-Bolt FSNT Housings For Tapered Bore Bearings66
 Two-Bolt SNT Housings For Cylindrical Bore Bearings70
 Four-Bolt FSNT Housings for Cylindrical Bore Bearings ...74
 Large Plummer Block Housings – 3000 And 3100 Series ...78
 Metric Shaft Diameters.....82

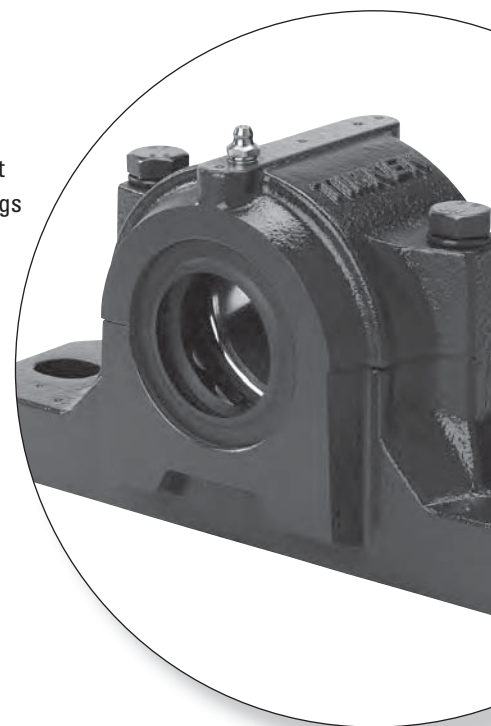

NOMENCLATURE

HOUSING STYLE

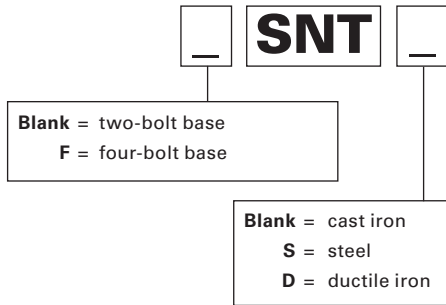

HOUSING SIZE

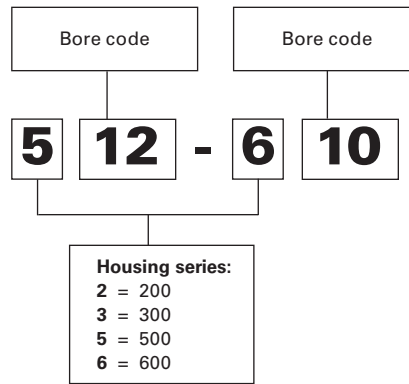

LOCATING RING

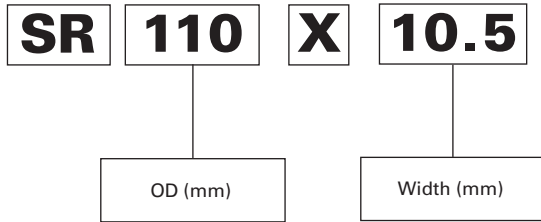

SLEEVE⁽¹⁾

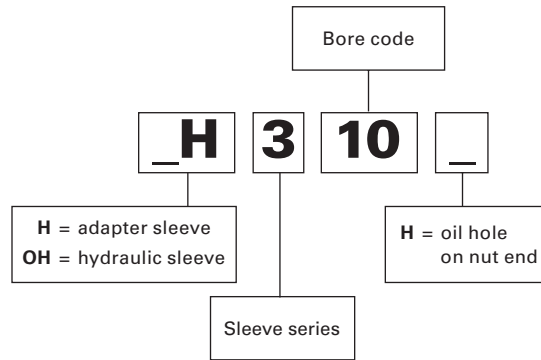

⁽¹⁾Sleeve assemblies contain adapter sleeve, locknut, and lockwasher

TABLE 17. TAPERED BORE BEARING EXAMPLE FOR SNT 512-610

Bearing	21310K	22310K	22212K
Locating rings	SR110X10.5	SR110X4	SR110X10
Sleeve	H310	H2310	H312
SEAL OPTIONS			
Double-lip	TSNG610	TSNG610	TSNG512
LOR	LO610	LO610	LO512
V-ring	VR610	VR610	VR512
Taconite	TA610	TA610	TA512
End cover	EC512-610	EC512-610	EC512-610

SEAL

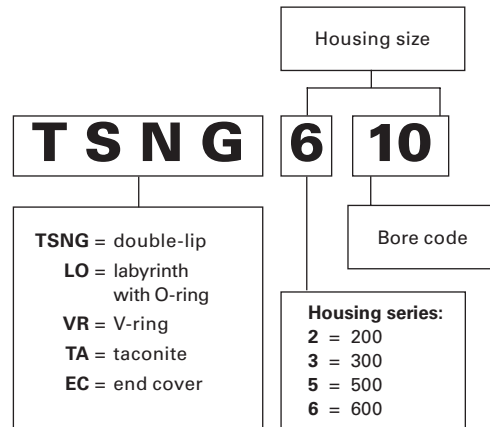

Fig. 12. SNT plummer block nomenclature.

INTRODUCTION

Timken's capabilities in engineering and manufacturing heavy-duty plummer blocks help ensure high performance from our products. In addition, Timken's worldwide sales organization is staffed with experienced engineers who are available for consultation on any plummer block or bearing application. If your design calls for shaft sizes or loads not listed in this catalog, contact your Timken engineer for information about availability of special units.

- **Sizes:** 20–400 mm shafts.
- **Applications:** Conveyors, ball mills, casters, rolling mills, heavy movable structures.
- **Features:** Split construction for convenient assembly and disassembly. These units include pry-tool slots and multiple alignment features to ease installation. There are center marks to simplify alignment and dimples for positioning pins and four-bolt mounting. Seal grooves allow for various sealing options.
- **Benefits:** Caps can be removed easily and quickly without damage to the bearing or housing. The design allows for simplified bearing inspection, service and replacement.

Split-block housings

Provide proper support with precision-fit matched cap-and-base with dowel pins. Simplifies alignment and installation of heavy housings. Convenient pry-tool slots for easy cap removal speeds bearing inspection and replacement.

Seal options

Protect the bearing with double-lip, labyrinth, V-ring and taconite sealing options.

Tapered adapter or straight bore mounting
Secure each bearing onto the shaft.

Standard metric mounting dimensions
Ease installation with same dimensions as industry norms for bolt holes, center heights and shaft diameters. Conforms to ISO 113:1999.

Timken® spherical roller bearings

Increase reliability with a high-performance bearing that runs cooler for longer bearing life.

Locating rings

Provide flexibility to fix or float the bearing.

Cast-iron

Rugged cast-iron is well-suited for harsh industrial applications. Available in steel or ductile iron.

Optional end caps

Avoid damage to bearing and housing. Easy to install and remove.

DESIGN AND CONSTRUCTION

Timken offers split plummer block housings that can be built with either tapered bore bearings with adapters for mounting on straight shafts or cylindrical bore bearings for assembly on shouldered shafts. Each offering includes all the accessories to meet a variety of needs.

Timken uses a system of doweling caps and bases together at an early stage of manufacturing, so that they remain a single unit during machining. They are not interchangeable as separate parts and become precisely mated components, helping to ensure a precise fit. Timken supplies plummer block housings for mounting with two or four bolts.

Standard caps and bases are made from high-grade, stress-relieved cast iron. They also are available in cast steel and ductile iron.

The illustration below (fig. 13) shows all parts of a plummer block assembly that are described throughout this section.



Fig. 13. SNT plummer block components and features.

MOUNTING

ADAPTER VERSUS STRAIGHT BORE

Typically, a spherical roller bearing plummer block assembly is mounted on a straight shaft using a tapered bore bearing and adapter assembly. Standard commercial shafting can be used without additional machining. (Suggested shaft diameters are shown in table 20 on page 82.) Adapter mount also permits maximum flexibility in the axial positioning of the bearing on the shaft and will accommodate light locational thrust loads. Timken plummer blocks for tapered bore and cylindrical bore are available.

Adapter-mounted spherical roller bearings require the correct removal of diametral clearance from the bearing to prevent relative rotation between inner race and sleeve or shaft. For proper shaft mounting of adapter-type spherical roller bearings, see page 21.

When application conditions produce heavy thrust loads, or a need exists for exact axial location or a positive shaft interference fit, a direct straight bore mounting may be the best option. This requires a shouldered shaft, machined for proper fit, and a straight bore bearing. Timken plummer block housings for straight bore applications are available for use with series 213, 222, 223 and 232.

Suggested fits for shafts in cylindrical bore spherical roller bearings are shown in the engineering section of this catalog in table 4 on page 23. For applications involving heavy shock, vibration, unbalanced rotating loads or other non-standard conditions, consult your Timken engineer.

FIXED AND FLOAT PLUMMER BLOCKS

SNT split plummer block components include two to six locating rings allowing for installation at either fixed or float positions on the shaft. For the fixed position, two or more locating rings are used on one or both sides of the bearing.

CLOSED-END INSTALLATIONS

In some applications, the shaft end is designed to terminate inside the plummer block. For this design, positive fitting end-cap inserts are available to help seal out contaminants and retain lubricant. Timken heavy-duty end covers provide sealing for closed-end applications.

Designers and installers need to make sure the shaft end does not contact the closure. A minimum of 3 mm clearance at maximum thermal expansion is suggested between the end of the shaft and the closure. Dimension Y, in the spherical roller bearing tables (pages 85–91), defines the maximum permissible length of the shaft from the centerline of the plummer block housing.

NOTE

Failure to employ proper mounting procedures can cause reduced bearing performance.

SNT LUBRICATION

Timken plummer block housings are designed for grease lubrication. They also can be modified to accommodate oil-bath and circulating oil- or oil/air-mist systems. Contact your Timken engineer for assistance. Please reference the installation guides on pages 55–59 for grease fill information.

Lubrication groove and holes may be provided in the bearing outer ring. This feature, designated by adding suffix W33 to the bearing number, should be specified whenever re-ordering bearings for pillow blocks. For bearings with lubrication groove and holes, it is suggested that the fresh lubricant is fed directly to the center of the bearing between the rows of rollers and distributed to the rest of the bearing. This helps ensure the used lubricant is purged from the bearing. Housed units feature multiple dimples that can be used to drill and tap for alternative grease fitting locations as needed.

SEALS

Timken® SNT plummer blocks are available with multiple sealing options. Each seal type incorporates specific features to meet your application needs. Table 18 compares the various features of each seal type.

DOUBLE-LIP SEALS

Double-lip seals are the most common seal design used with SNT plummer blocks. These are general all purpose elastomer seals that can protect in moderately contaminated environments. The seal is split into two 180 degree halves for easy installation. The seal element runs against the shaft surface and should be used in grease lubricated blocks. *Contact your Timken engineer for double-lip seal availability when using cylindrical bore housings.*

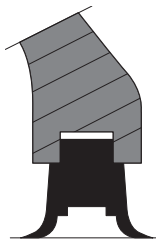

Fig. 14.
Double-lip seals.

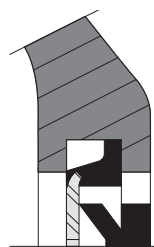

Fig. 15.
V-ring seals.

V-RING SEALS

V-ring seals are a deflector type seal. They are made up of an elastomer V-ring seal element that rotates with the shaft and runs against the axial surface of a washer-type component that is retained in the block housing. As the V-ring element is a stretch fit onto the shaft, a rougher shaft surface is acceptable. This seal performs well in moderately contaminated environments with fine particulate.

LABYRINTH SEALS

Labyrinth seals are made up of a single metal ring component that interconnects with the grooves in the housing to form a labyrinth gap. The inside diameter of the metal ring contains an O-ring that creates an interference fit with the shaft so that the ring will rotate with the shaft. Labyrinth seals can be used on high-speed applications and in moderately contaminated environments.

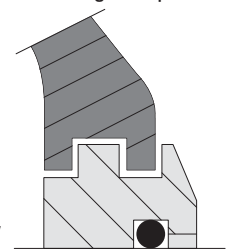

Fig. 16.
Labyrinth seals.

TACONITE SEALS

Taconite seals are a combination of both a labyrinth seal and V-ring seal. The labyrinth seal is made up of two separate metal ring components, inner and outer, that have interconnecting grooves that form a labyrinth gap. The outer metal ring component contains an O-ring on its outside diameter that provides an interference fit to the groove in the housing. The inside diameter of the inner metal ring component contains an O-ring that creates an interference fit with the shaft so that the ring will rotate with the shaft. This seal performs well in highly contaminated environments such as those seen in mining operations.

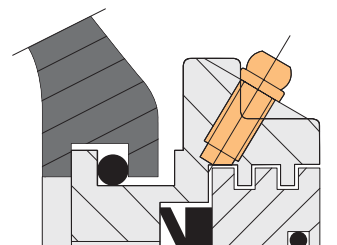

Fig. 17. Taconite seals.

TABLE 18. SEAL SELECTION

Seal Selection	Double-Lip (TSNG)	V-Ring (VR)	Labyrinth (LO)	Taconite (TA)
Material	NBR	NBR rubber + mild steel plate	Steel + NBR O-ring	Steel + NBR O-ring and V-ring
Temperature	-40° to 100° C (-40° to 212° F)	-40° to 100° C (-40° to 212° F)	-40° to 120° C (-40° to 248° F)	-40° to 100° C (-40° to 212° F)
Maximum speed	8 m/s	7 m/s	Same as bearing	7 m/s
Grease relubrication	Excellent	Excellent	Good	Good
Oil lubrication ⁽¹⁾	Poor	Poor	Poor	Poor
Low friction	Good	Good	Excellent	Good
Resists dust/fine particles	Excellent	Excellent	Good	Excellent
Resists coarse particles	Good	Poor	Excellent	Good
Resists water	Good	Good	Fair	Good
Misalignment Shaft dia. ≤ 100 mm	1°	1.5°	0.3°	0.3°
Misalignment Shaft dia. > 100 mm	0.5°	1°	0.3°	0.3°

⁽¹⁾If an application requires oil lubrication, please contact your Timken engineer.

LOAD RATINGS AND LIFE

Load ratings for the spherical roller bearings that are used in plummer blocks are found in the dimension tables on pages 85 through 91. Life calculation formulas are found in the Engineering Manual (order no. 10424) on page 48 available on www.timken.com.

In addition to individual bearing selection, the ability of the plummer block to carry the operating load should be considered.

It should be noted that the load rating figures supplied in this catalog are applicable only when the load direction is generally toward the base of the plummer block. If the plummer block must be mounted so the load can be applied in any other direction, consult your Timken engineer.

INSTALLATION GUIDES

Following are installation guides for the SNT housings and the four seal types offered by Timken.

MOUNTING HOUSINGS WITH DOUBLE-LIP SEALS

Prior to starting installation, please read the following instructions. Contact a Timken engineer with any questions.

1. Clean the work area. Check the dimensional and form accuracy of the shaft seat. Note: The shaft roundness specification should be half of the O.D. tolerance. Ensure the shaft is free from burrs, gouges or other imperfections.
2. Ensure the surface roughness of the support surface $R_a \leq 12.5 \mu\text{m}$. Ensure flatness is within 0.08 mm (base) and 0.125 mm aggregate (housing base and mounting surface).
3. Determine the position of the housing relative to the adapter sleeve on the shaft for bearings on adapter sleeves. For bearings that have to be relubricated from the side, the grease fitting in the housing cap should always face away from the locknut on the adapter sleeve. When housings are mounted on the end of a shaft, grease must be supplied at the end cover side. Make sure to position the base correctly because the cap only fits in one direction.
4. Position the housing on the support surface. Fit the attachment bolts but do not tighten them (fig. 18a).
5. Insert one seal half in each of the grooves in the housing base. Fill the space between the two sealing lips with grease (fig. 18b). If the housing is used on the end of a shaft, insert an end cover on one side instead of the seal half.
6. Mount the bearing on the shaft – either directly on a stepped shaft or using an adapter sleeve. Completely fill the bearing with grease. The remainder of the suggested grease quantity can be placed in the housing, equally distributed on each side of the bearing (See grease fill).
7. Install the shaft with bearing in the housing base (fig. 19a).
8. Put one locating ring on each side of the bearing for locating bearing arrangements (fig. 19b).
9. Carefully align the housing base. Use the vertical markings at the middle of the side faces and end faces of the housing base to help with this (fig. 20a). Then lightly tighten the attachment bolts (fig. 20b).
10. The remaining seal halves must be inserted in the seal grooves in the housing cap and the space between the sealing lips filled with grease.
11. Check the cap and base to see that they show the same identification. Install the cap onto the base (fig. 21a) and tighten the cap bolts to the torque specified in the table.
12. Fully tighten the attachment bolts in the housing base (fig. 21b). Suggested tightening torques are given in the table.

For torque table and grease fill information, please see page 59.

Fig. 18

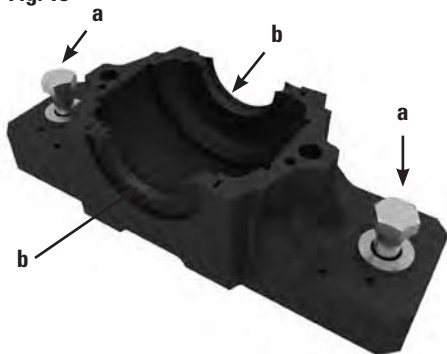

Fig. 19

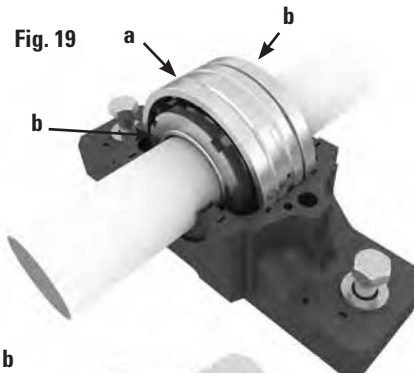

Fig. 20

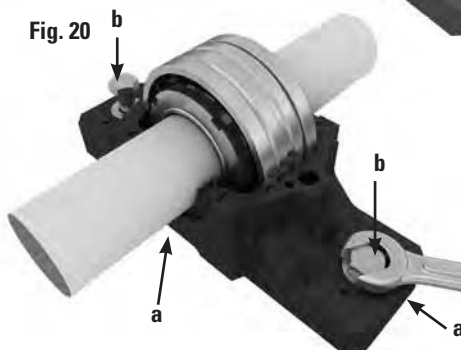

Fig. 21



MOUNTING HOUSINGS WITH LABYRINTH SEALS

Prior to starting installation, please read the following instructions. Contact a Timken engineer with any questions.

1. Clean the work area. Check the dimensional and form accuracy of the shaft seat. Note: The shaft roundness specification should be half of the O.D. tolerance. Ensure the shaft is free from burrs, gouges or other imperfections.
2. Ensure the surface roughness of the support surface $Ra \leq 12.5 \mu\text{m}$. Ensure flatness is within 0.08 mm (base) and 0.125 mm aggregate (housing base and mounting surface).
3. For bearings on adapter sleeves, determine the position of the housing relative to the adapter sleeve on the shaft. For bearings that have to be relubricated from the side, the grease fitting in the housing cap should always face away from the locknut on the adapter sleeve. Grease should be supplied at the end cover side where housings are mounted on the end of a shaft. Be sure to position the base correctly since the cap only fits in one direction.
4. Position the housing on the support surface. Fit the attachment bolts but do not tighten them (fig. 22).
5. Mount the labyrinth ring on the shaft (fig. 23a).
6. Mount the bearing on the shaft – either directly on a stepped shaft or using an adapter sleeve (fig. 23b). Completely fill the bearing with grease. The remainder of the suggested grease quantity can be placed in the housing, equally distributed on each side of the bearing (See grease fill).
7. Mount the second labyrinth ring on the shaft in the correct position (fig. 23c). If the housing is to be used on the end of a shaft, omit the second labyrinth ring and insert an end cover in the housing base instead.
8. Install the shaft with bearing and labyrinth ring(s) in the housing base (fig. 24a).
9. Place one locating ring on each side of the bearing for locating bearing arrangements (fig. 24b).
10. Align the housing base. Use the vertical markings at the middle of the side faces and end faces of the housing base to help with this. Tighten the attachment bolts (fig. 24c).
11. Check the cap and base to see that they have the same identification. Install the cap onto the base (fig. 25a) and tighten the cap bolts to the torque specified in the table.
12. Fully tighten the attachment bolts in the housing base (fig. 25b). Suggested tightening torques are given in the table.
13. Insert the hollow O-ring cord of synthetic rubber in the grooves in the labyrinth rings. Use a screwdriver while turning the shaft, take care not to damage the seal (fig. 25c).

For torque table and grease fill information, please see page 59.

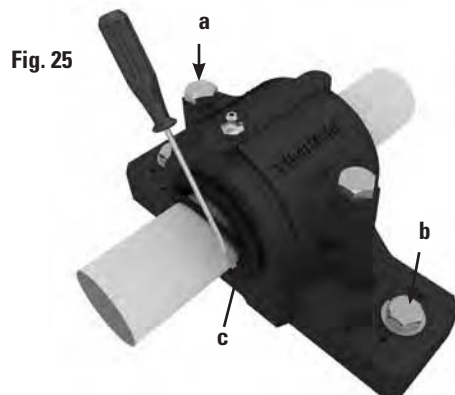
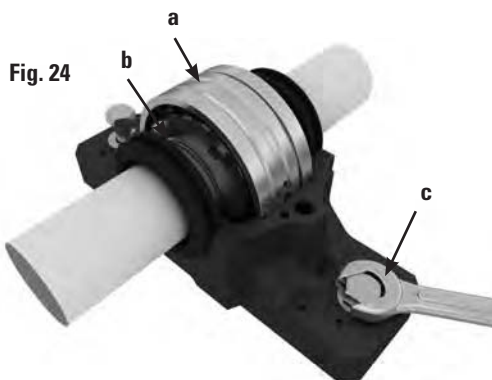

MOUNTING HOUSINGS WITH V-RING SEALS

Prior to starting installation, please read the following instructions. Contact a Timken engineer with any questions.

1. Ensure the work area is clean. Check the dimensional and form accuracy of the shaft seat. Note: The shaft roundness specification should be half of the O.D. tolerance. Ensure the shaft is free from burrs, gouges or other imperfections.
2. Ensure the surface roughness of the support surface $Ra \leq 12.5 \mu\text{m}$. Ensure flatness is within 0.08 mm (base) and 0.125 mm aggregate (housing base and mounting surface).
3. Determine the position of the housing relative to the adapter sleeve on the shaft for bearings on adapter sleeves. For bearings that have to be relubricated from the side, the grease fitting in the housing cap should always face away from the locknut on the adapter sleeve. Grease should be supplied at the end cover side where housings are mounted on the end of a shaft. Make sure to position the base correctly since the cap only fits in one direction.
4. Position the housing on the support surface. Fit the attachment bolts but do not tighten them (fig. 26).
5. Arrange the one V-ring with sealing washer on the shaft. The V-ring should be furthest away from the bearing and seal against the washer, i.e. the lip should point inward the washer (fig. 27a).
6. Mount the bearing on the shaft – either directly on a stepped shaft or using an adapter sleeve (fig. 27b). Completely fill the bearing with grease. The remainder of the suggested grease quantity can be placed in the housing, equally distributed on each side of the bearing (See grease fill).
7. Arrange the second sealing washer and V-ring on the shaft at the other side of the bearing (fig. 27c). If the housing is to be used on the end of a shaft, mount an end cover instead.
8. Install the shaft with bearing and sealing washers in the housing base (fig. 28a).
9. Put one locating ring on each side of the bearing for locating bearing arrangements.
10. Align the housing base. Use the vertical markings at the middle of the side faces and end faces of the housing base to help with this. Lightly tighten the attachment bolts (fig. 28b).
11. Check the cap and base to see that they bear the same identification. Install the cap onto the base and tighten the cap bolts to the torque marked in the table (fig. 29a).
12. Tighten the attachment bolts in the housing base (fig. 29b). Check the table for suggested tightening torques.
13. Coat the V-ring counterfaces on the sealing washers with grease (fig. 29c).
14. Finally, push the V-ring seals into their correct position. This can be done using a punch or screwdriver to push the seal as the shaft is turned, take care not to damage the seal (fig. 30).

For torque table and grease fill information, please see page 59.

Fig. 26

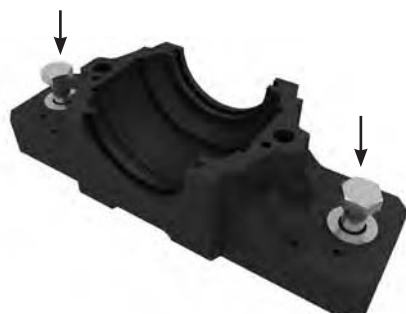

Fig. 27

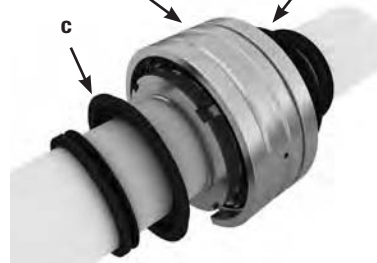

Fig. 28



Fig. 29



Fig. 30



MOUNTING HOUSINGS WITH TACONITE SEALS

Prior to starting installation, please read the following instructions. Contact a Timken engineer with any questions.

1. Ensure the work area is clean. Check the dimensional and form accuracy of the shaft seat. Note: The shaft roundness specification should be half of the O.D. tolerance. Ensure the shaft is free from burrs, gouges or other imperfections.
2. Ensure the surface roughness of the support surface $Ra \leq 12.5 \mu\text{m}$ (500 μin). Ensure flatness is within 0.08 mm (base) and 0.125 mm aggregate (housing base and mounting surface).
3. For bearings on adapter sleeves, determine the position of the housing relative to the adapter sleeve on the shaft. For bearings that have to be relubricated from the side, the grease fitting in the housing cap should always face away from the locknut on the adapter sleeve. Where housings are mounted on the end of a shaft, grease should be supplied at the end cover side. Be sure to position the base correctly since the cap only fits in one direction.
4. Position the housing on the support surface. Fit the attachment bolts but do not tighten them (fig. 31).
5. Mount the first V-ring together with one labyrinth ring on the shaft in the correct position (fig. 32a). The lip of the V-ring should point towards the bearing. Place the split ring parts over the V-ring and labyrinth ring and screw them together (fig. 32b). The two parts of this split ring are not interchangeable. Check to see that they carry the same identification.
6. Mount the bearing on the shaft (fig. 32c) – either directly on a stepped shaft or using an adapter sleeve. Fill the bearing with grease. The remainder of the suggested grease quantity can be placed in the housing, equally distributed on each side of the bearing (See grease fill).
7. Mount the second seal according to step 5 (fig. 32d). If the housing is to be used on the end of a shaft, omit the second seal and insert an end cover in the housing base instead.
8. Use the hollow O-section cord to fix the labyrinth ring in position on the shaft (fig. 32c). Use a screwdriver to fit the cords while rotating the shaft, taking care not to damage the cords. Mount the O-rings on the seal outer diameter.
9. Install the shaft with bearing and seals in the housing base (fig. 33a) taking care that the hollow O-section cords are not damaged.
10. For locating bearing arrangements put one locating ring on each side of the bearing.
11. Carefully align the housing base. Use the vertical markings at the middle of the side faces and end faces of the housing base to help facilitate this (fig. 33b). Tighten the attachment bolts (fig. 33c).
12. Check the cap and base to make sure they have the same identification. Install the cap onto the base (fig. 34a) and tighten the cap bolts to the torque specified in the table.
13. Fully tighten the attachment bolts in the housing base (fig. 34b). Suggested tightening torques are given in the table.
14. Finally, before the first test run, rotate the shaft and supply grease via the fitting until it purges from the labyrinth rings (fig. 34c). Use the same grease for the bearing and the labyrinth rings.

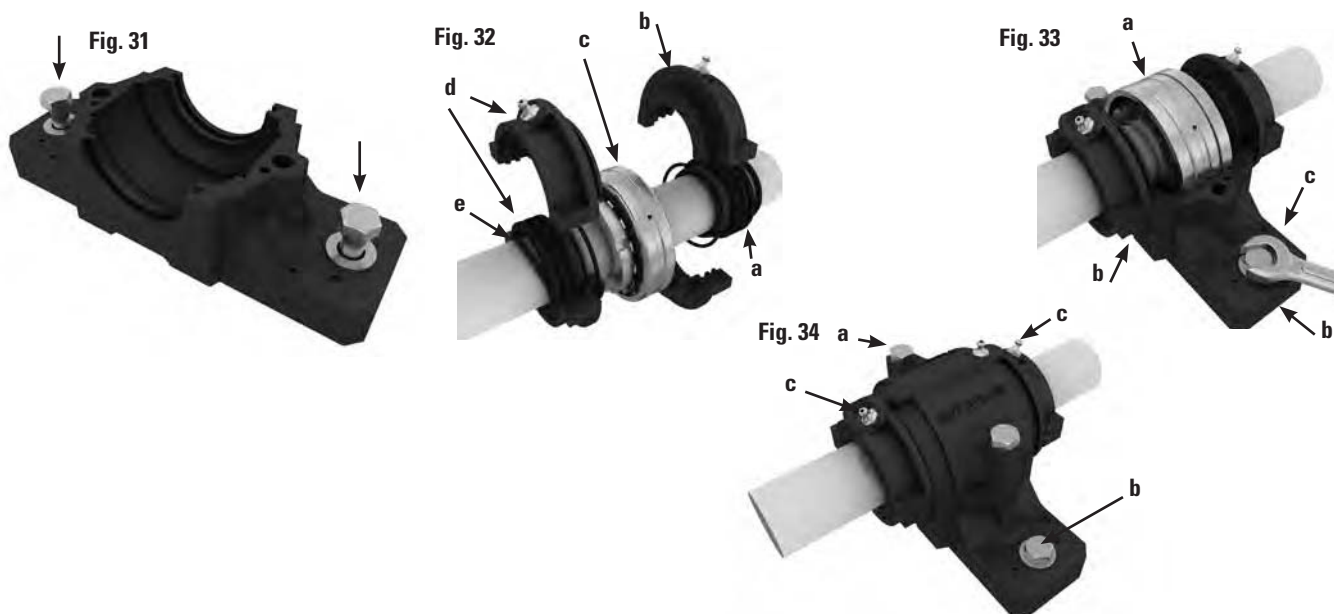

GREASE FILL

- For normal industrial applications, fill bearing void to 100 percent and housing void to 40–60 percent.
- For low-speed applications (less than 20 RPM), fill bearing void to 100 percent and housing void to 60–100 percent.
- For high-speed applications (above 70 percent of the bearings thermal speed rating), fill bearing void to 100 percent and housing void to 30–40 percent.

Contact a Timken engineer with any questions.

ADDITIONAL REFERENCE FOR BEARING MOUNTING

Timken Industrial Maintenance Manual (order no. 10213), Timken Spherical Roller Bearing Catalog (order no. 10446), pages 14–41 or www.timken.com.

TABLE 19. TIGHTENING TORQUE – CAP BOLTS AND ATTACHMENT BOLTS

Housing SNT	Cap Bolts		Attachment Bolts	
	Bolt Size	Torque Nm	Bolt Size	Torque Nm
505, 205	M10x40	50	M12	80
505-605-206-305	M10x40	50	M12	80
507-606, 207	M10x50	50	M12	80
508-607, 208-307	M10x50	50	M12	80
509, 209	M10x50	50	M12	80
510-60, 208-307	M10x55	50	M12	80
511-609, 211	M12x60	80	M16	200
512-610, 212	M12x60	80	M16	200
513-611,213	M12x65	80	M16	200
515-612, 215	M12x65	80	M16	200
516-613, 216	M12x70	80	M20	385
517, 217	M12x80	80	M20	385
518-615, 218	M16x19	150	M20	385
519-616	M16x19	150	M20	385
520-617	M20x200	200	M24	665
522-619	M20x100	200	M24	665
524-620	M20x110	200	M24	665
526	M24x130	350	M24	665
528	M24x130	350	M30	1310
530	M24x130	350	M30	1310
532	M24x130	350	M30	1310

 **WARNING**
Failure to observe the following warnings could create a risk of death or serious injury.

Proper maintenance and handling practices are critical. Always follow installation instructions and maintain proper lubrication.

Overheated bearings can ignite explosive atmospheres. Special care must be taken to properly select, install, maintain, and lubricate housed unit bearings that are used in or near atmospheres that may contain explosive levels of combustible gases or accumulations of dust such as from grain, coal, or other combustible materials. Consult your equipment designer or supplier for installation and maintenance instructions.

 **CAUTION**
Failure to follow these cautions could create a risk of injury.

If a hammer and bar are used for installation or removal of a part, use a mild steel bar (e.g., 1010 or 1020 grade). Mild steel bars are less likely to cause release of high speed fragments from the hammer or bar or the part being removed.

CAUTION
Failure to follow these cautions may result in property damage.

Do not use damaged housed units. The use of a damaged housed unit can result in equipment damage and/or injury.

This information is not intended to substitute for the specific recommendations of your equipment suppliers.

Every reasonable effort has been made to ensure the accuracy of the information contained in this writing, but no liability is accepted for errors, omissions or for any other reason.

TWO-BOLT SNT HOUSINGS FOR TAPERED BORE BEARINGS

- The basic numbers for ordering plummer block housings and components are listed in the table below.
- Each housing includes the housing cap, base and cap bolts.
- Housings shown are furnished in cast iron. If cast steel is desired, add the letter S to the alpha prefix (e.g., SNTS 518). If ductile iron is desired, add the letter D to the alpha prefix (e.g., SNTD 505).

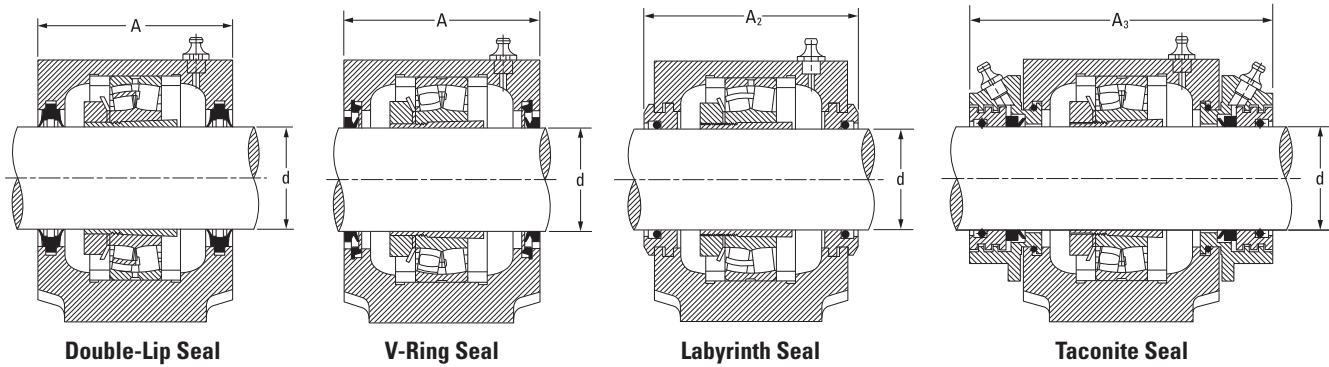

Shaft Dia.	Housing	Bearing	Locating Rings ⁽¹⁾	Adapter Sleeve ⁽²⁾	Locknut ⁽³⁾	Lockwasher ⁽³⁾	Double-Lip Seal ⁽⁴⁾	V-Ring Seal ⁽⁴⁾	Labyrinth Seal ⁽³⁾	Taconite Seal ⁽³⁾	End Cover ⁽³⁾
d			O.D. x Width								
mm											
20	SNT 505 SNT 506-605	22205K 21305K	SR52X3.5 SR62X7.5	H305 H305	KM5 KM5	MB5 MB5	– TSNG605	VR505 VR605	LO505 LO605	TA505 TA605	EC505 EC506-605
25	SNT 506-605 SNT 507-606	22206K 21306K	SR62X6 SR72X7.5	H306 H306	KM6 KM6	MB6 MB6	– TSNG606	VR506 VR606	LO506 LO606	TA506 TA606	EC506-605 EC507-606
30	SNT 507-606 SNT 508-607	22207K 21307K	SR72X5.5 SR80X9	H307 H307	KM7 KM7	MB7 MB7	TSNG507 TSNG607	VR507 VR607	LO507 LO607	TA507 TA607	EC507-606 EC508-607
35	SNT 508-607 SNT 510-608 SNT 510-608	22208K 21308K 22308K	SR80X8 SR90X9 SR90X4	H308 H308 H2308	KM8 KM8 KM8	MB8 MB8 MB8	TSNG508 TSNG608 TSNG608	VR508 VR608 VR608	LO508 LO608 LO608	TA508 TA608 TA608	EC508-607 EC510-608 EC510-608
40	SNT 509 SNT 511-609 SNT 511-609	22209K 21309K 22309K	SR85X3.5 SR100X9.5 SR100X4	H309 H309 H2309	KM9 KM9 KM9	MB9 MB9 MB9	TSNG509 TSNG609 TSNG609	VR509 VR609 VR609	LO509 LO609 LO609	TA509 TA609 TA609	EC509 EC511-609 EC511-609
45	SNT 510-608 SNT 512-610 SNT 512-610	22210K 21310K 22310K	SR90X9 SR110X10.5 SR110X4	H310 H310 H2310	KM10 KM10 KM10	MB10 MB10 MB10	TSNG510 TSNG610 TSNG610	VR510 VR610 VR610	LO510 LO610 LO610	TA510 TA610 TA610	EC510-608 EC512-610 EC512-610
50	SNT 511-609 SNT 513-611 SNT 513-611	22211K 21311K 22311K	SR100X9.5 SR120X11 SR120X4	H311 H311 H2311	KM11 KM11 KM11	MB11 MB11 MB11	TSNG511 TSNG611 TSNG611	VR511 VR611 VR611	LO511 LO611 LO611	TA511 TA611 TA611	EC511-609 EC513-611 EC513-611

⁽¹⁾Locating rings = minimum two required for fixed position, sold one piece per box.

⁽²⁾Adapter sleeve assembly includes one sleeve, one locknut and one lockwasher.

⁽³⁾Labyrinth, taconite seal, end cover, locknut, lockwasher, sold one piece per box.

⁽⁴⁾Double-lip and V-ring seals sold two pieces per box.

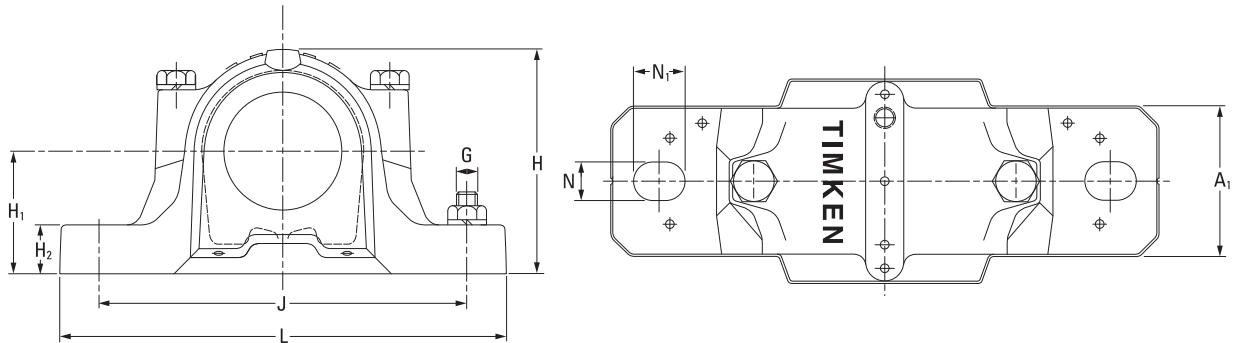

Housing Dimensions													2 Bolts Req'd	Housing Mass
A	A ₁	A ₂	A ₃	H	H ₁	H ₂	J min	J	J max	L	N	N ₁	G	
67	46	80	130	74	40	19	123	130	137	165	15	20	12	1.5
77	52	89	135	89	50	22	143	150	157	185	15	20	12	2.0
77	52	89	135	89	50	22	143	150	157	185	15	20	12	2.0
82	52	94	140	93	50	22	143	150	157	185	15	20	12	2.2
85	60	97	145	108	60	25	165	170	175	205	15	20	12	2.9
85	60	97	145	108	60	25	165	170	175	205	15	20	12	2.9
90	60	102	150	113	60	25	165	170	175	205	15	20	12	3.2
90	60	102	150	113	60	25	165	170	175	205	15	20	12	3.2
85	60	97	150	109	60	25	165	170	175	205	15	20	12	2.9
95	70	107	155	128	70	28	205	210	215	255	18	24	16	4.5
95	70	107	155	128	70	28	205	210	215	255	18	24	16	4.5
90	60	102	150	113	60	25	165	170	175	205	15	20	12	3.2
105	70	117	165	134	70	30	205	210	215	255	18	24	16	5.3
105	70	117	165	134	70	30	205	210	215	255	18	24	16	5.3
95	70	107	155	128	70	28	205	210	215	255	18	24	16	4.5
110	80	122	170	150	80	30	224	230	236	275	18	24	16	6.6
110	80	122	170	150	80	30	224	230	236	275	18	24	16	6.6

Continued on next page.

TWO-BOLT SNT HOUSINGS FOR TAPERED BORE BEARINGS – continued

- The basic numbers for ordering plummer block housings and components are listed in the table below.
- Each housing includes the housing cap, base and cap bolts.
- Housings shown are furnished in cast iron. If cast steel is desired, add the letter S to the alpha prefix (e.g., SNTS 518). If ductile iron is desired, add the letter D to the alpha prefix (e.g., SNTD 505).

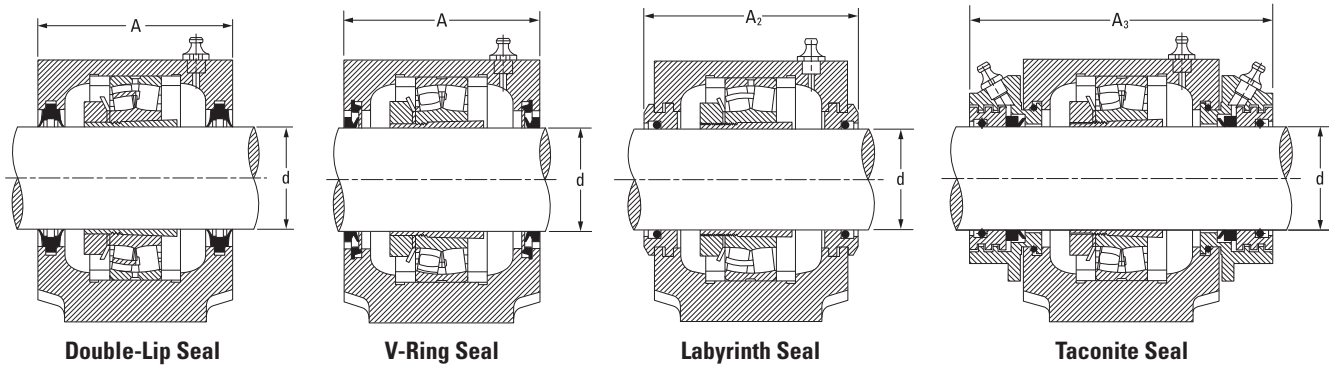

Continued from previous page.

Shaft Dia.	Housing	Bearing	Locating Rings ⁽¹⁾	Adapter Sleeve ⁽²⁾	Locknut ⁽³⁾	Lockwasher ⁽³⁾	Double-Lip Seal ⁽⁴⁾	V-Ring Seal ⁽⁴⁾	Labyrinth Seal ⁽³⁾	Taconite Seal ⁽³⁾	End Cover ⁽³⁾
d			O.D. x Width								
mm											
55	SNT 512-610	22212K	SR110X10	H312	KM12	MB12	TSNG512	VR512	LO512	TA512	EC512-610
	SNT 515-612	21312K	SR130X12.5	H312	KM12	MB12	TSNG612	VR612	LO612	TA612	EC515-612
	SNT 515-612	22312K	SR130X5	H2312	KM12	MB12	TSNG612	VR612	LO612	TA612	EC515-612
60	SNT 513-611	22213K	SR120X10	H313	KM13	MB13	TSNG513	VR513	LO513	TA513	EC513-611
	SNT 516-613	21313K	SR140X12.5	H313	KM13	MB13	TSNG613	VR613	LO613	TA613	EC516-613
	SNT 516-613	22313K	SR140X5	H2313	KM13	MB13	TSNG613	VR613	LO613	TA613	EC516-613
65	SNT 515-612	22215K	SR130X12.5	H315	KM15	MB15	TSNG515	VR515	LO515	TA515	EC515-612
	SNT 518-615	21315K	SR160X14	H315	KM15	MB15	TSNG615	VR615	LO615	TA615	EC518-615
	SNT 518-615	22315K	SR160X5	H2315	KM15	MB15	TSNG615	VR615	LO615	TA615	EC518-615
70	SNT 516-613	22216K	SR140X12.5	H316	KM16	MB16	TSNG516	VR516	LO516	TA516	EC516-613
	SNT 519-616	21316K	SR170X14.5	H316	KM16	MB16	TSNG616	VR616	LO616	TA616	EC519-616
	SNT 519-616	22316K	SR170X5	H2316	KM16	MB16	TSNG616	VR616	LO616	TA616	EC519-616
75	SNT 517	22217K	SR150X12.5	H317	KM17	MB17	TSNG517	VR517	LO517	TA517	EC517
	SNT 520-617	21317K	SR180X14.5	H317	KM17	MB17	TSNG617	VR617	LO617	TA617	EC520-617
	SNT 520-617	22317K	SR180X5	H2317	KM17	MB17	TSNG617	VR617	LO617	TA617	EC520-617
80	SNT 518-615	22218K	SR160X12.5	H318	KM18	MB18	TSNG518	VR518	LO518	TA518	EC518-615
	SNT 518-615	23218K	SR160X6.25	H2318	KM18	MB18	TSNG518	VR518	LO518	TA518	EC518-615
85	SNT 519-616	22219K	SR170X12.5	H319	KM19	MB19	TSNG519	VR519	LO519	TA519	EC519-616
	SNT 522-619	21319K	SR200X17.5	H319	KM19	MB19	TSNG619	VR619	LO619	TA619	EC522-619
	SNT 522-619	22319K	SR200X6.5	H2319	KM19	MB19	TSNG619	VR619	LO619	TA619	EC522-619

⁽¹⁾Locating rings = minimum two required for fixed position, sold one piece per box.

⁽²⁾Adapter sleeve assembly includes one sleeve, one locknut and one lockwasher.

⁽³⁾Labyrinth, taconite seal, end cover, locknut, lockwasher, sold one piece per box.

⁽⁴⁾Double-lip and V-ring seals sold two pieces per box.

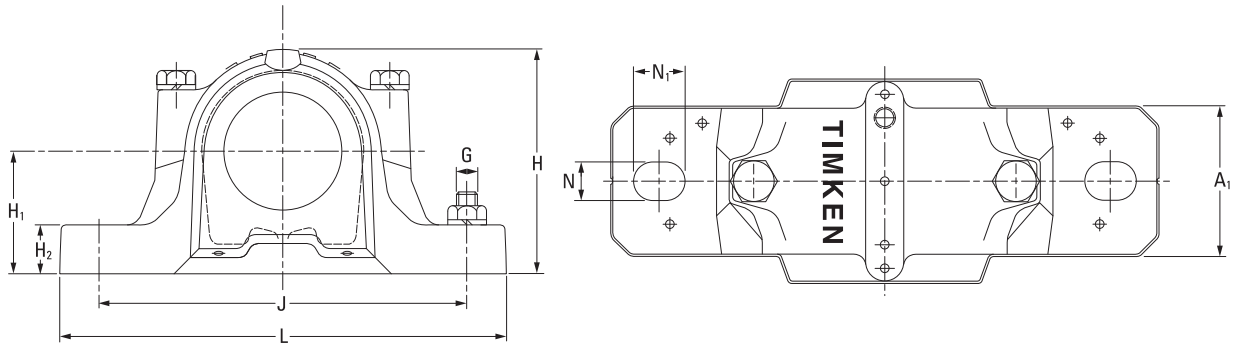

Housing Dimensions													2 Bolts Req'd	Housing Mass
A	A ₁	A ₂	A ₃	H	H ₁	H ₂	J min	J	J max	L	N	N ₁	G	
105	70	117	165	134	70	30	205	210	215	255	18	24	16	5.3
115	80	127	175	156	80	30	222	230	238	280	18	24	16	6.9
115	80	127	175	156	80	30	222	230	238	280	18	24	16	6.9
110	80	122	170	150	80	30	224	230	236	275	18	24	16	6.6
120	90	138	180	177	95	32	252	260	268	315	22	28	20	9.7
120	90	138	180	177	95	32	252	260	268	315	22	28	20	9.7
115	80	127	175	156	80	30	222	230	238	280	18	24	16	6.9
140	100	158	225	194	100	35	285	290	295	345	22	28	20	13.1
140	100	158	225	194	100	35	285	290	295	345	22	28	20	13.1
120	90	138	180	177	95	32	252	260	268	315	22	28	20	9.7
145	100	163	220	212	112	35	285	290	295	345	22	28	20	14.0
145	100	163	220	212	112	35	285	290	295	345	22	28	20	14.0
125	90	143	210	183	95	32	252	260	268	320	22	28	20	10.4
160	110	178	235	218	112	40	314	320	326	380	26	32	24	17.6
160	110	178	235	218	112	40	314	320	326	380	26	32	24	17.6
140	100	158	225	194	100	35	285	290	295	345	22	28	20	13.1
140	100	158	225	194	100	35	285	290	295	345	22	28	20	13.1
145	100	163	220	212	112	35	285	290	295	345	22	28	20	14.0
175	120	191	250	242	125	45	356	344	350	410	32	26	24	22.3
175	120	191	250	242	125	45	344	350	356	410	26	32	24	22.3

Continued on next page.

TWO-BOLT SNT HOUSINGS FOR TAPERED BORE BEARINGS – continued

- The basic numbers for ordering plummer block housings and components are listed in the table below.
- Each housing includes the housing cap, base and cap bolts.
- Housings shown are furnished in cast iron. If cast steel is desired, add the letter S to the alpha prefix (e.g., SNTS 518). If ductile iron is desired, add the letter D to the alpha prefix (e.g., SNTD 505).

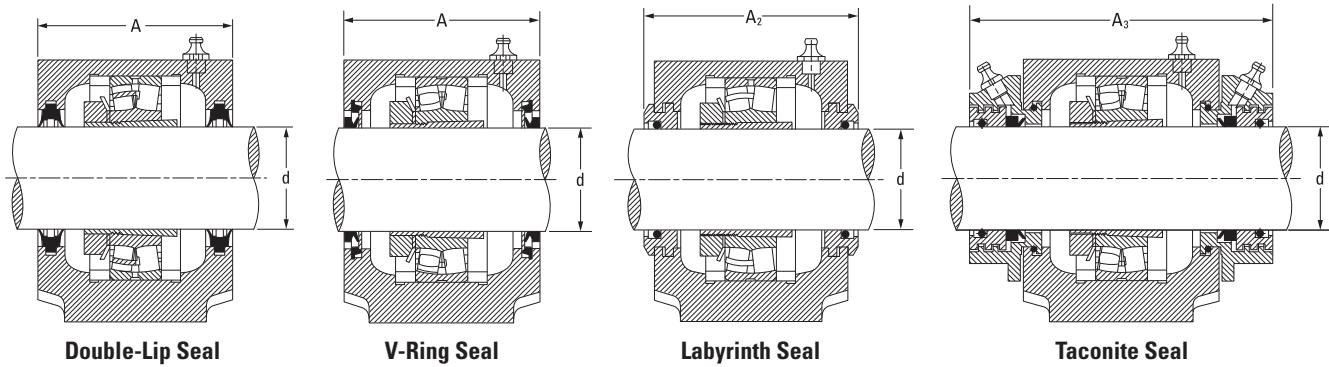

Continued from previous page.

Shaft Dia.	Housing	Bearing	Locating Rings ⁽¹⁾	Adapter Sleeve ⁽²⁾	Locknut ⁽³⁾	Lockwasher ⁽³⁾	Double-Lip Seal ⁽⁴⁾	V-Ring Seal ⁽⁴⁾	Labyrinth Seal ⁽³⁾	Taconite Seal ⁽³⁾	End Cover ⁽³⁾
d			O.D. x Width								
mm											
90	SNT 520-617	22220K	SR180X12	H320	KM20	MB20	TSNG520	VR520	LO520	TA520	EC520-617
	SNT 520-617	23220K	SR180X4.85	H2320	KM20	MB20	TSNG520	VR520	LO520	TA520	EC520-617
	SNT 524-620	21320K	SR215X19.5	H2320	KM20	MB20	TSNG620	VR620	LO620	TA620	EC524-620
	SNT 524-620	22320K	SR215X6.5	H2320	KM20	MB20	TSNG620	VR620	LO620	TA620	EC524-620
100	SNT 522-619	22222K	SR200X13.5	H322	KM22	MB22	TSNG522	VR522	LO522	TA522	EC522-619
	SNT 522-619	23222K	SR200X5.1	H2322	KM22	MB22	TSNG522	VR522	LO522	TA522	EC522-619
110	SNT 524-620	22224K	SR215X14	H3124	KM24	MB24	TSNG524	VR524	LO524	TA524	EC524-620
	SNT 524-620	23224K	SR215X5	H2324	KM24	MB24	TSNG524	VR524	LO524	TA524	EC524-620
115	SNT 526	22226K	SR230X13	H3126	KM26	MB26	TSNG526	VR526	LO526	TA526	EC526
	SNT 526	23226K	SR230X5	H2326	KM26	MB26	TSNG526	VR526	LO526	TA526	EC526
125	SNT 528	22228K	SR250X15	H3128	KM28	MB28	TSNG528	VR528	LO528	TA528	EC528
	SNT 528	23228K	SR250X5	H2328	KM28	MB28	TSNG528	VR528	LO528	TA528	EC528
135	SNT 530	22230K	SR270X16.5	H3130	KM30	MB30	TSNG530	VR530	LO530	TA530	EC530
	SNT 530	23230K	SR270X5	H2330	KM30	MB30	TSNG530	VR530	LO530	TA530	EC530
140	SNT 532	22232K	SR290X17	H3132	KM32	MB32	TSNG532	VR532	LO532	TA532	EC532
	SNT 532	23232K	SR290X5	H2332	KM32	MB32	TSNG532	VR532	LO532	TA532	EC532

⁽¹⁾Locating rings = minimum two required for fixed position, sold one piece per box.

⁽²⁾Adapter sleeve assembly includes one sleeve, one locknut and one lockwasher.

⁽³⁾Labyrinth, taconite seal, end cover, locknut, lockwasher, sold one piece per box.

⁽⁴⁾Double-lip and V-ring seals sold two pieces per box.

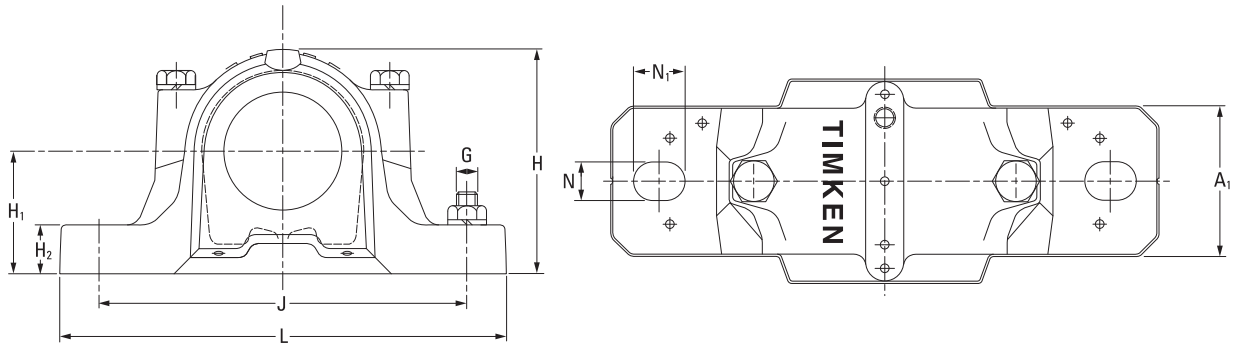

Housing Dimensions													2 Bolts Req'd	Housing Mass
A	A ₁	A ₂	A ₃	H	H ₁	H ₂	J min	J	J max	L	N	N ₁	G	
160	110	178	235	218	112	40	314	320	326	380	26	32	24	17.6
160	110	178	235	218	112	40	314	320	326	380	26	32	24	17.6
185	120	199	260	271	140	45	344	350	356	410	26	32	24	26.5
185	120	199	260	271	140	45	344	350	356	410	26	32	24	26.5
175	120	191	250	242	125	45	344	350	356	410	26	32	24	22.3
175	120	191	250	242	125	45	344	350	356	410	26	32	24	22.3
185	120	199	260	271	140	45	344	350	356	410	26	32	24	26.5
185	120	199	260	271	140	45	344	350	356	410	26	32	24	26.5
190	130	208	265	290	150	50	373	380	387	445	28	35	24	34.0
190	130	208	265	290	150	50	373	380	387	445	28	35	24	34.0
205	150	223	285	302	150	50	413	420	427	500	35	42	30	39.0
205	150	223	285	302	150	50	413	420	427	500	35	42	30	39.0
220	160	241	295	323	160	60	443	450	457	530	35	42	30	48.0
220	160	241	295	323	160	60	443	450	457	530	35	42	30	48.0
235	160	254	315	344	170	60	463	470	477	550	35	42	30	54.5
235	160	254	315	344	170	60	463	470	477	550	35	42	30	54.5

FOUR-BOLT FSNT HOUSINGS FOR TAPERED BORE BEARINGS

- The basic numbers for ordering plummer block housings and components are listed in the table below.
- Each housing includes the housing cap, base and cap bolts.
- Assemblies shown are furnished in cast iron. If cast steel is desired, add the letter S to the alpha prefix (e.g., FSNTS 518). If ductile iron is desired, add the letter D to the alpha prefix (e.g., FSNTD 505).

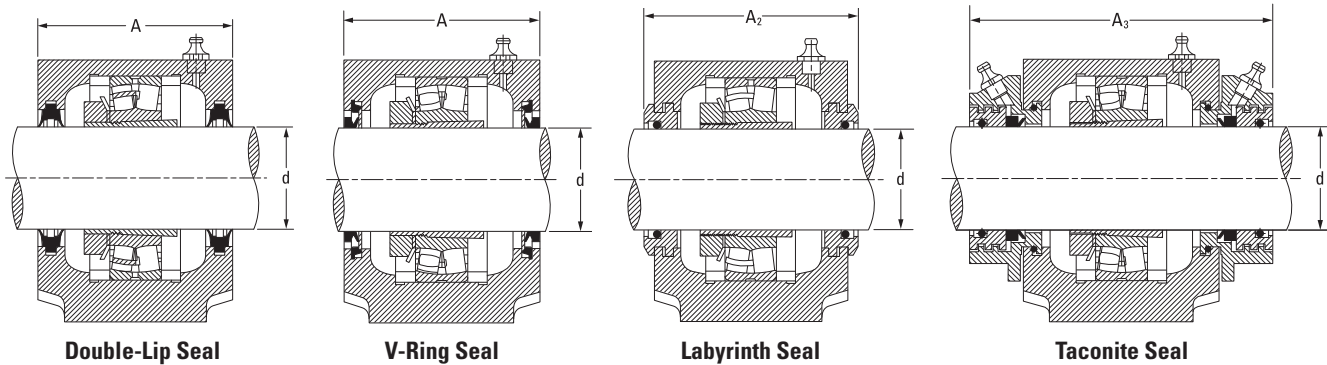

Shaft Dia.	Housing	Bearing	Locating Rings ⁽¹⁾	Adapter Sleeve ⁽²⁾	Locknut ⁽³⁾	Lockwasher ⁽³⁾	Double-Lip Seal ⁽⁴⁾	V-Ring Seal ⁽⁴⁾	Labyrinth Seal ⁽³⁾	Taconite Seal ⁽³⁾	End Cover ⁽³⁾
d			O.D. x Width								
mm											
40	FSNT 511-609	21309K	SR100X9.5	H309	KM9	MB9	TSNG609	VR609	LO609	TA609	EC511-609
	FSNT 511-609	22309K	SR100X4	H2309	KM9	MB9	TSNG609	VR609	LO609	TA609	EC511-609
45	FSNT 512-610	21310K	SR110X10.5	H310	KM10	MB10	TSNG610	VR610	LO610	TA610	EC512-610
	FSNT 512-610	22310K	SR110X4	H2310	KM10	MB10	TSNG610	VR610	LO610	TA610	EC512-610
50	FSNT 511-609	22211K	SR100X9.5	H311	KM11	MB11	TSNG511	VR511	LO511	TA511	EC511-609
	FSNT 513-611	21311K	SR120X11	H311	KM11	MB11	TSNG611	VR611	LO611	TA611	EC513-611
	FSNT 513-611	22311K	SR120X4	H2311	KM11	MB11	TSNG611	VR611	LO611	TA611	EC513-611
55	FSNT 512-610	22212K	SR110X10	H312	KM12	MB12	TSNG512	VR512	LO512	TA512	EC512-610
	FSNT 515-612	21312K	SR130X12.5	H312	KM12	MB12	TSNG612	VR612	LO612	TA612	EC515-612
	FSNT 515-612	22312K	SR130X5	H2312	KM12	MB12	TSNG612	VR612	LO612	TA612	EC515-612
60	FSNT 513-611	22213K	SR120X10	H313	KM13	MB13	TSNG513	VR513	LO513	TA513	EC513-611
	FSNT 516-613	21313K	SR140X12.5	H313	KM13	MB13	TSNG613	VR613	LO613	TA613	EC516-613
	FSNT 516-613	22313K	SR140X5	H2313	KM13	MB13	TSNG613	VR613	LO613	TA613	EC516-613
65	FSNT 515-612	22215K	SR130X12.5	H315	KM15	MB15	TSNG515	VR515	LO515	TA515	EC515-612
	FSNT 518-615	21315K	SR160X14	H315	KM15	MB15	TSNG615	VR615	LO615	TA615	EC518-615
	FSNT 518-615	22315K	SR160X5	H2315	KM15	MB15	TSNG615	VR615	LO615	TA615	EC518-615
70	FSNT 516-613	22216K	SR140X12.5	H316	KM16	MB16	TSNG516	VR516	LO516	TA516	EC516-613
	FSNT 519-616	21316K	SR170X14.5	H316	KM16	MB16	TSNG616	VR616	LO616	TA616	EC519-616
	FSNT 519-616	22316K	SR170X5	H2316	KM16	MB16	TSNG616	VR616	LO616	TA616	EC519-616
75	FSNT 517	22217K	SR150X12.5	H317	KM17	MB17	TSNG517	VR517	LO517	TA517	EC517
	FSNT 520-617	21317K	SR180X14.5	H317	KM17	MB17	TSNG617	VR617	LO617	TA617	EC520-617
	FSNT 520-617	22317K	SR180X5	H2317	KM17	MB17	TSNG617	VR617	LO617	TA617	EC520-617

⁽¹⁾Locating rings = minimum two required for fixed position, sold one piece per box.

⁽²⁾Adapter sleeve assembly includes one sleeve, one locknut and one lockwasher.

⁽³⁾Labyrinth, taconite seal, end cover, locknut, lockwasher, sold one piece per box.

⁽⁴⁾Double-lip and V-ring seals sold two pieces per box.

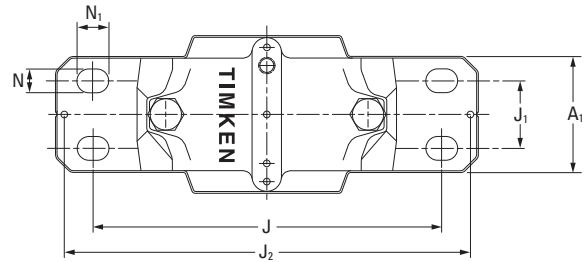
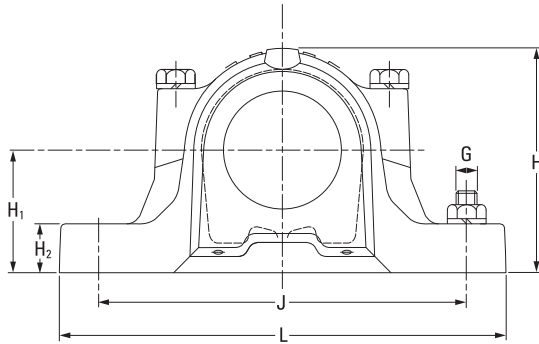

Housing Dimensions													4 Bolts Req'd	Housing Mass
A	A ₁	A ₂	A ₃	H	H ₁	H ₂	J	J ₁	J ₂	L	N	N ₁	G	
mm	mm	mm	mm	mm	mm	mm	mm	mm	mm	mm	mm	mm	mm	mm
95	70	107	155	128	70	28	210	35	234	255	15	20	12	4.5
95	70	107	155	128	70	28	210	35	234	255	15	20	12	4.5
105	70	117	165	134	70	30	210	35	234	255	15	20	12	5.3
105	70	117	165	134	70	30	210	35	234	255	15	20	12	5.3
95	70	107	155	128	70	28	210	35	234	255	15	20	12	4.5
110	80	122	170	150	80	30	230	40	252	275	15	20	12	6.6
110	80	122	170	150	80	30	230	40	252	275	15	20	12	6.6
105	70	117	165	134	70	30	210	35	234	255	15	20	12	5.3
115	80	127	175	156	80	30	230	40	257	280	15	20	12	6.9
115	80	127	175	156	80	30	230	40	257	280	15	20	12	6.9
110	80	122	170	150	80	30	230	40	252	275	15	20	12	6.6
120	90	138	180	177	95	32	260	50	288	315	18	24	16	9.7
120	90	138	180	177	95	32	260	50	288	315	18	24	16	9.7
115	80	127	175	156	80	30	230	40	257	280	15	20	12	6.9
140	100	158	225	194	100	35	290	50	317	345	18	24	16	13.1
140	100	158	225	194	100	35	290	50	317	345	18	24	16	13.1
120	90	138	180	177	95	32	260	50	288	315	18	24	16	9.7
145	100	163	220	212	112	35	290	50	317	345	18	24	16	14.0
145	100	163	220	212	112	35	290	50	317	345	18	24	16	14.0
125	90	143	210	183	95	32	260	50	292	320	18	24	16	10.4
160	110	178	235	218	112	40	320	60	348	380	18	24	16	17.6
160	110	178	235	218	112	40	320	60	348	380	18	24	16	17.6

Continued on next page.

FOUR-BOLT FSNT HOUSINGS FOR TAPERED BORE BEARINGS – continued

- The basic numbers for ordering plummer block housings and components are listed in the table below.
- Each housing includes the housing cap, base and cap bolts.
- Assemblies shown are furnished in cast iron. If cast steel is desired, add the letter S to the alpha prefix (e.g., FSNTS 518). If ductile iron is desired, add the letter D to the alpha prefix (e.g., FSNTD 505).

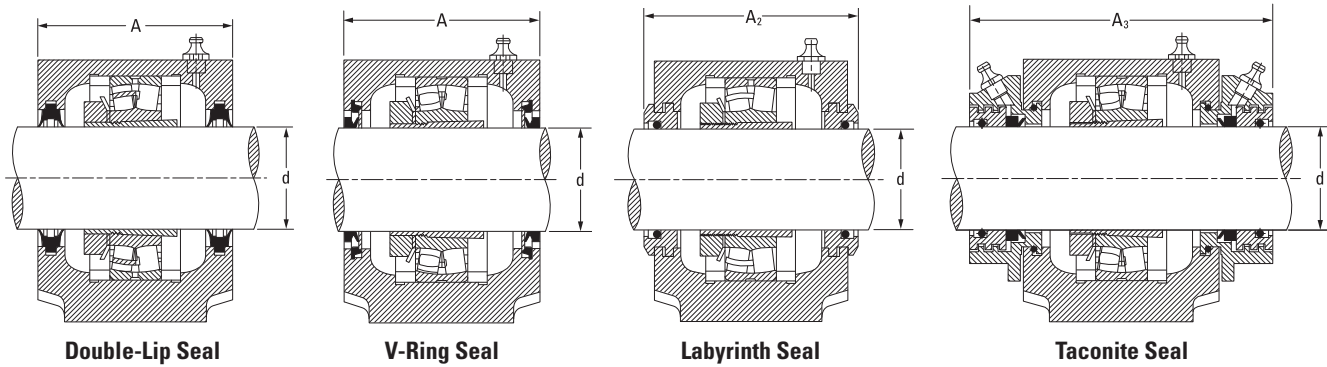

Continued from previous page.

Shaft Dia.	Housing	Bearing	Locating Rings ⁽¹⁾	Adapter Sleeve ⁽²⁾	Locknut ⁽³⁾	Lockwasher ⁽³⁾	Double-Lip Seal ⁽⁴⁾	V-Ring Seal ⁽⁴⁾	Labyrinth Seal ⁽³⁾	Taconite Seal ⁽³⁾	End Cover ⁽³⁾
d			O.D. x Width								
mm											
80	FSNT 518-615	22218K	SR160X12.5	H318	KM18	MB18	TSNG518	VR518	L0518	TA518	EC518-615
	FSNT 518-615	23218K	SR160X6.25	H2318	KM18	MB18	TSNG518	VR518	L0518	TA518	EC518-615
85	FSNT 519-616	22219K	SR170X12.5	H319	KM19	MB19	TSNG519	VR519	L0519	TA519	EC519-616
	FSNT 522-619	21319K	SR200X17.5	H319	KM19	MB19	TSNG619	VR619	L0619	TA619	EC522-619
	FSNT 522-619	22319K	SR200X6.5	H2319	KM19	MB19	TSNG619	VR619	L0619	TA619	EC522-619
90	FSNT 520-617	22220K	SR180X12	H320	KM20	MB20	TSNG520	VR520	L0520	TA520	EC520-617
	FSNT 520-617	23220K	SR180X4.85	H2320	KM20	MB20	TSNG520	VR520	L0520	TA520	EC520-617
	FSNT 524-620	21320K	SR215X19.5	H320	KM20	MB20	TSNG620	VR620	L0620	TA620	EC524-620
	FSNT 524-620	22320K	SR215X6.5	H2320	KM20	MB20	TSNG620	VR620	L0620	TA620	EC524-620
100	FSNT 522-619	22222K	SR200X13.5	H322	KM22	MB22	TSNG522	VR522	L0522	TA522	EC522-619
	FSNT 522-619	23222K	SR200X5.1	H2322	KM22	MB22	TSNG522	VR522	L0522	TA522	EC522-619
110	FSNT 524-620	22224K	SR215X14	H3124	KM24	MB24	TSNG524	VR524	L0524	TA524	EC524-620
	FSNT 524-620	23224K	SR215X5	H2324	KM24	MB24	TSNG524	VR524	L0524	TA524	EC524-620
115	FSNT 526	22226K	SR230X13	H3126	KM26	MB26	TSNG526	VR526	L0526	TA526	EC526
	FSNT 526	23226K	SR230X5	H2326	KM26	MB26	TSNG526	VR526	L0526	TA526	EC526
125	FSNT 528	22228K	SR250X15	H3128	KM28	MB28	TSNG528	VR528	L0528	TA528	EC528
	FSNT 528	23228K	SR250X5	H2328	KM28	MB28	TSNG528	VR528	L0528	TA528	EC528
135	FSNT 530	22230K	SR270X16.5	H3130	KM30	MB30	TSNG530	VR530	L0530	TA530	EC530
	FSNT 530	23230K	SR270X5	H2330	KM30	MB30	TSNG530	VR530	L0530	TA530	EC530
140	FSNT 532	22232K	SR290X17	H3132	KM32	MB32	TSNG532	VR532	L0532	TA532	EC532
	FSNT 532	23232K	SR290X5	H2332	KM32	MB32	TSNG532	VR532	L0532	TA532	EC532

⁽¹⁾Locating rings = minimum two required for fixed position, sold one piece per box.

⁽²⁾Adapter sleeve assembly includes one sleeve, one locknut and one lockwasher.

⁽³⁾Labyrinth, taconite seal, end cover, locknut, lockwasher, sold one piece per box.

⁽⁴⁾Double-lip and V-ring seals sold two pieces per box.

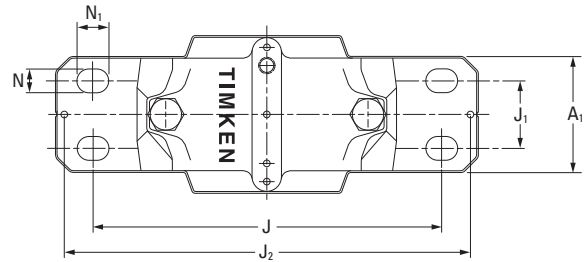
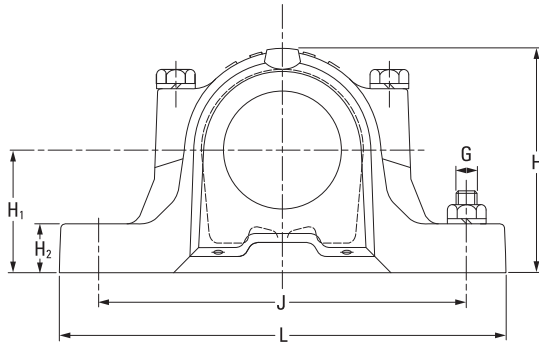

Housing Dimensions													4 Bolts Req'd	Housing Mass
A	A ₁	A ₂	A ₃	H	H ₁	H ₂	J	J ₁	J ₂	L	N	N ₁	G	
mm	mm	mm	mm	mm	mm	mm	mm	mm	mm	mm	mm	mm	mm	mm
140	100	158	225	194	100	35	290	50	317	345	18	24	16	13.1
140	100	158	225	194	100	35	290	50	317	345	18	24	16	13.1
145	100	163	220	212	112	35	290	50	317	345	18	24	16	14.0
175	120	191	250	242	125	45	350	70	378	410	18	24	16	22.3
175	120	191	250	242	125	45	350	70	378	410	18	24	16	22.3
160	110	178	235	218	112	40	320	60	348	380	18	24	16	17.6
160	110	178	235	218	112	40	320	60	348	380	18	24	16	17.6
185	120	199	260	271	140	45	350	70	378	410	18	24	16	26.5
185	120	199	260	271	140	45	350	70	378	410	18	24	16	26.5
175	120	191	250	242	125	45	350	70	378	410	18	24	16	22.3
175	120	191	250	242	125	45	350	70	378	410	18	24	16	22.3
185	120	199	260	271	140	45	350	70	378	410	18	24	16	26.5
185	120	199	260	271	140	45	350	70	378	410	18	24	16	26.5
190	130	208	265	290	150	50	380	70	414	445	22	28	20	34.0
190	130	208	265	290	150	50	380	70	414	445	22	28	20	34.0
205	150	223	285	302	150	50	420	80	458	500	26	32	24	39.0
205	150	223	285	302	150	50	420	80	458	500	26	32	24	39.0
220	160	241	295	323	160	60	450	90	486	530	26	32	24	48.0
220	160	241	295	323	160	60	450	90	486	530	26	32	24	48.0
235	160	254	315	344	170	60	470	90	506	550	26	32	24	54.5
235	160	254	315	344	170	60	470	90	506	550	26	32	24	54.5

TWO-BOLT SNT HOUSINGS FOR CYLINDRICAL BORE BEARINGS

- The basic numbers for ordering plummer block housings and components are listed in the table below.
- Each housing includes the housing cap, base and cap bolts.
- Assemblies shown are furnished in cast iron. If cast steel is desired, add the letter S to the alpha prefix (e.g., FSNTS 518).

If ductile iron is desired, add the letter D to the alpha prefix (e.g., FSNTD 505).

- Seal sleeve for d_a shaft to be supplied by customer and should have same O.D. as d_b .

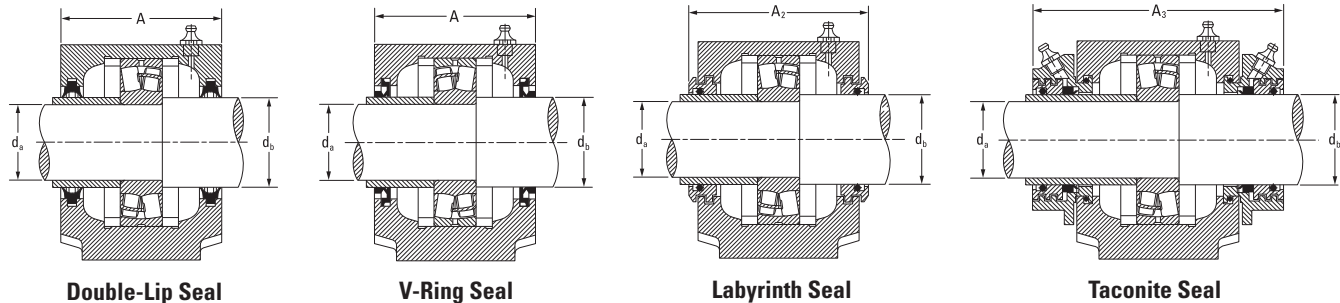

Shaft Dia.		Housing	Bearing	Locating Rings ⁽¹⁾ O.D. x Width	Double-Lip Seal ⁽²⁾	V-Ring Seal ⁽²⁾	Labyrinth Seal ⁽³⁾	Taconite Seal ⁽³⁾	End Cover ⁽³⁾
d_a	d_b								
mm	mm								
25	30	SNT 205 SNT 206-305	22205 21305	SR52X3.5 SR62X7.5	TSNG205 TSNG305	– VR305	L0205 L0305	TA205 TA305	EC506-605 EC507-606
30	35	SNT 206-305 SNT 507-606	22206 21306	SR62X6 SR72X7.5	TSNG206 TSNG306	VR206 VR306	L0206 L0306	TA206 TA306	EC507-606 EC507-606
35	45	SNT 207 SNT 208-307	22207 21307	SR72X5.5 SR80X9	TSNG207 TSNG307	VR207 VR307	L0207 L0307	TA207 TA307	EC509 EC510-608
40	50	SNT 208-307 SNT 510-608 SNT 510-608	22208 21308 22308	SR80X8 SR90X9 SR90X4	TSNG208 TSNG308 TSNG308	VR208 VR308 VR308	L0208 L0308 L0308	TA208 TA308 TA308	EC510-608 EC510-608 EC510-608
45	55	SNT 209 SNT 511-609 SNT 511-609	22209 21309 22309	SR85X3.5 SR100X9.5 SR100X4	TSNG209 TSNG309 TSNG309	VR209 VR309 VR309	L0209 L0309 L0309	TA209 TA309 TA309	EC511-609 EC511-609 EC511-609
50	60	SNT 210 SNT 512-610 SNT 512-610	22210 21310 22310	SR90X9 SR110X10.5 SR110X4	TSNG210 TSNG310 TSNG310	VR210 VR310 VR310	L0210 L0310 L0310	TA210 TA310 TA310	EC512-610 EC512-610 EC512-610
55	65	SNT 211 SNT 513-611 SNT 513-611	22211 21311 22311	SR100X9.5 SR120X11 SR120X4	TSNG211 TSNG311 TSNG311	VR211 VR311 VR311	L0211 L0311 L0311	TA211 TA311 TA311	EC513-611 EC513-611 EC513-611
60	70	SNT 212 SNT 515-612 SNT 515-612	22212 21312 22312	SR110X10 SR130X12.5 SR130X5	TSNG212 TSNG312 TSNG312	VR212 VR312 VR312	L0212 L0312 L0312	TA212 TA312 TA312	EC515-612 EC515-612 EC515-612
65	75	SNT 213 SNT 516-613 SNT 516-613	22213 21313 22313	SR120X10 SR140X12.5 SR140X5	TSNG213 TSNG313 TSNG313	VR213 VR313 VR313	L0213 L0313 L0313	TA213 TA313 TA313	EC516-613 EC516-613 EC516-613
70	80	SNT 517 SNT 517	22314 21314	SR150X5 SR150X13	TSNG314 TSNG314	VR314 VR314	L0314 L0314	TA314 TA314	EC517 EC517

⁽¹⁾Locating rings = minimum two required for fixed position, sold one piece per box.

⁽²⁾Double-lip and V-ring seals sold two pieces per box. Consult your Timken engineer for double-lip seal availability.

⁽³⁾Labyrinth, taconite seal and end cover, sold one piece per box.

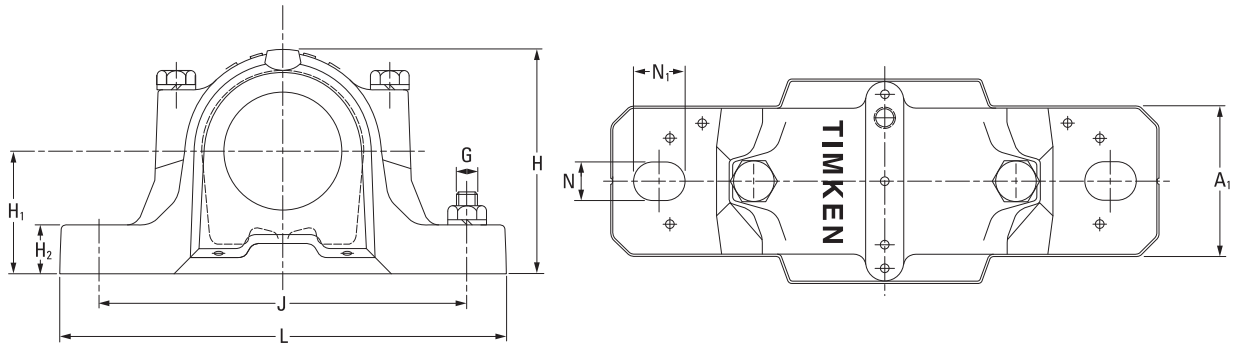

Housing Dimensions													2 Bolts Req'd	Housing Mass
A	A ₁	A ₂	A ₃	H	H ₁	H ₂	J min	J	J max	L	N	N ₁	G	kg
mm	mm	mm	mm	mm	mm	mm	mm	mm	mm	mm	mm	mm	mm	kg
67	46	90	140	74	40	19	123	130	137	165	15	20	12	1.5
77	52	89	150	89	50	22	143	150	157	185	15	20	12	2.0
77	52	89	150	89	50	22	143	150	157	185	15	20	12	2.0
82	52	94	140	93	50	22	143	150	157	185	15	20	12	2.2
82	52	96	155	93	50	22	143	150	157	185	15	20	12	2.2
85	60	99	160	108	60	25	165	170	175	205	15	20	12	2.9
85	60	99	160	108	60	25	165	170	175	205	15	20	12	2.9
90	60	102	150	113	60	25	165	170	175	205	15	20	12	3.2
90	60	102	150	113	60	25	165	170	175	205	15	20	12	3.2
85	60	97	160	109	60	25	165	170	175	205	15	20	12	2.9
95	70	107	155	128	70	28	205	210	215	255	18	24	16	4.5
95	70	107	155	128	70	28	205	210	215	255	18	24	16	4.5
90	60	102	165	113	60	25	165	170	175	205	15	20	12	3.2
105	70	117	165	134	70	30	205	210	215	255	18	24	16	5.3
105	70	117	165	134	70	30	205	210	215	255	18	24	16	5.3
95	70	107	170	128	70	28	205	210	215	255	18	24	16	4.5
110	80	122	170	150	80	30	224	230	236	275	18	24	16	6.6
110	80	122	170	150	80	30	224	230	236	275	18	24	16	6.6
105	70	117	180	134	70	30	205	210	215	255	18	24	16	5.2
115	80	127	175	156	80	30	222	230	238	280	18	24	16	6.9
115	80	127	175	156	80	30	222	230	238	280	18	24	16	6.9
110	80	128	190	149	80	30	222	230	238	275	18	24	16	6.6
120	90	138	180	177	95	32	252	260	268	315	22	28	20	9.7
120	90	138	180	177	95	32	252	260	268	315	22	28	20	9.7
125	90	143	210	183	95	32	252	260	268	320	22	28	20	10.4
125	90	143	210	183	95	32	252	260	268	320	22	28	20	10.4

Continued on next page.

TWO-BOLT SNT HOUSINGS FOR CYLINDRICAL BORE BEARINGS – continued

- The basic numbers for ordering plummer block housings and components are listed in the table below.
- Each housing includes the housing cap, base and cap bolts.
- Assemblies shown are furnished in cast iron. If cast steel is desired, add the letter S to the alpha prefix (e.g., FSNTS 518).

If ductile iron is desired, add the letter D to the alpha prefix (e.g., FSNTD 505).

- Seal sleeve for d_a shaft to be supplied by customer and should have same O.D. as d_b .

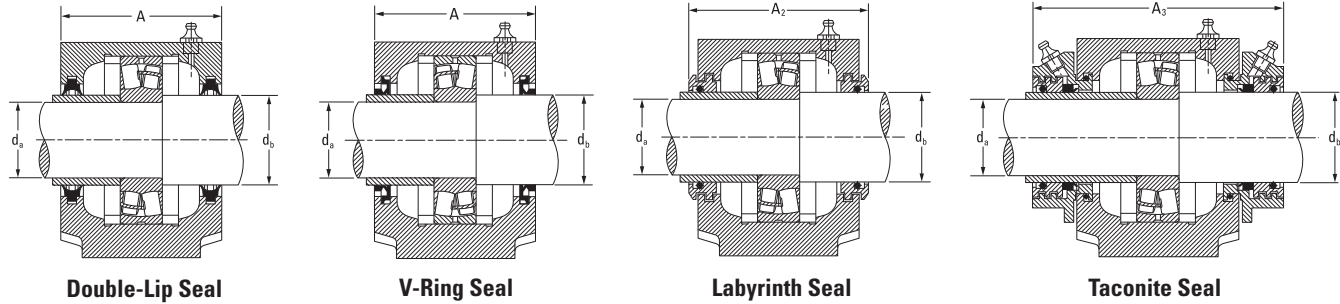

Continued from previous page.

Shaft Dia.		Housing	Bearing	Locating Rings ⁽¹⁾ O.D. x Width	Double-Lip Seal ⁽²⁾	V-Ring Seal ⁽²⁾	Labyrinth Seal ⁽³⁾	Taconite Seal ⁽³⁾	End Cover ⁽³⁾
d_a	d_b								
mm	mm								
75	85	SNT 215	22215	SR130X12.5	TSNG215	VR215	L0215	TA215	EC518-615
		SNT 518-615	21315	SR160X14	TSNG315	VR315	L0315	TA315	EC518-615
		SNT 518-615	22315	SR160X5	TSNG315	VR315	L0315	TA315	EC518-615
80	90	SNT 216	22216	SR140X10	TSNG216	VR216	L0216	TA216	EC216
		SNT 519-616	21316	SR170X14.5	TSNG316	VR316	L0316	TA316	EC519-616
		SNT 519-616	22316	SR170X5	TSNG316	VR316	L0316	TA316	EC519-616
85	95	SNT 217	22217	SR150X12.5	TSNG217	VR217	L0217	TA217	EC217
		SNT 520-617	21317	SR180X14.5	TSNG317	VR317	L0317	TA317	EC520-617
		SNT 520-617	22317	SR180X5	TSNG317	VR317	L0317	TA317	EC520-617
90	100	SNT 218	22218	SR160X12.5	TSNG218	VR218	L0218	TA218	EC218
		SNT 218	23218	SR160X6.25	TSNG218	VR218	L0218	TA218	EC218
95	110	SNT 522-619	21319	SR200X17.5	TSNG319	VR319	L0319	TA319	EC522-619
		SNT 522-619	22319	SR200X6.5	TSNG319	VR319	L0319	TA319	EC522-619
100	115	SNT 520-617	22220	SR180X12	TSNG220	VR220	L0220	TA220	EC520-617
		SNT 520-617	23220	SR180X4.85	TSNG220	VR220	L0220	TA220	EC520-617
		SNT 524-620	21320	SR215X19.5	TSNG320	VR320	L0320	TA320	EC524-620
		SNT 524-620	22320	SR215X6.5	TSNG320	VR320	L0320	TA320	EC524-620
110	125	SNT 522-619	22222	SR200X13.5	TSNG222	VR222	L0222	TA222	EC522-619
		SNT 522-619	23222	SR200X5.1	TSNG222	VR222	L0222	TA222	EC522-619
120	135	SNT 524-620	22224	SR215X14	TSNG224	VR224	L0224	TA224	EC 524-620
		SNT 524-620	23224	SR215X5	TSNG224	VR224	L0224	TA224	EC 524-620
130	145	SNT 526	22226	SR230X13	TSNG226	VR226	L0226	TA226	EC526
		SNT 526	23226	SR230X5	TSNG226	VR226	L0226	TA226	EC526
140	155	SNT 528	22228	SR250X15	TSNG228	VR228	L0228	TA228	EC528
		SNT 528	23228	SR250X5	TSNG228	VR228	L0228	TA228	EC528
150	165	SNT 530	22230	SR270X16.5	TSNG230	VR230	L0230	TA230	EC530
		SNT 530	23230	SR270X5	TSNG230	VR230	L0230	TA230	EC530
160	175	SNT 532	22232	SR290X17	TSNG232	VR232	L0232	TA232	EC532
		SNT 532	23232	SR290X5	TSNG232	VR232	L0232	TA232	EC532

⁽¹⁾Locating rings = minimum two required for fixed position, sold one piece per box.

⁽²⁾Double-lip and V-ring seals sold two pieces per box. Consult your Timken engineer for double-lip seal availability.

⁽³⁾Labyrinth, taconite seal and end cover, sold one piece per box.

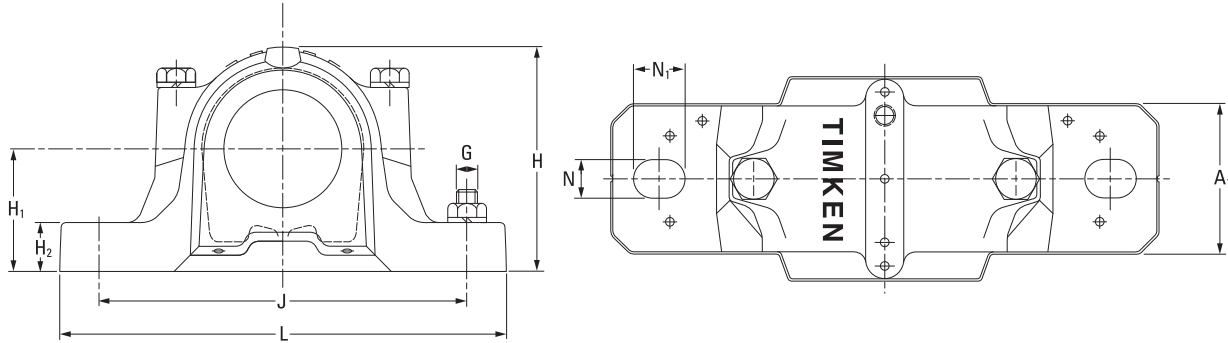

Housing Dimensions													2 Bolts Req'd	Housing Mass
A	A ₁	A ₂	A ₃	H	H ₁	H ₂	J min	J	J max	L	N	N ₁	G	
mm	mm	mm	mm	mm	mm	mm	mm	mm	mm	mm	mm	mm	mm	kg
115	80	133	195	155	80	30	222	230	238	280	18	24	16	6.9
140	100	158	225	194	100	35	285	290	295	345	22	28	20	13.1
140	100	158	225	194	100	35	285	290	295	345	22	28	20	13.1
120	90	138	200	177	95	32	252	260	268	315	22	28	20	9.7
145	100	163	220	212	112	35	285	290	295	345	22	28	20	14.0
145	100	163	220	212	112	35	285	290	295	345	22	28	20	14.0
125	90	143	205	183	95	32	252	260	268	315	22	28	20	10.4
160	110	178	235	218	112	40	314	320	326	380	26	32	24	17.6
160	110	178	235	218	112	40	314	320	326	380	26	32	24	17.6
140	100	158	220	194	100	35	285	290	295	345	22	28	20	13.1
140	100	158	220	194	100	35	285	290	295	345	22	28	20	13.1
175	120	191	250	242	125	45	344	350	356	410	26	32	24	22.3
175	120	191	250	242	125	45	344	350	356	410	26	32	24	22.3
160	110	178	235	218	112	40	314	320	326	380	26	32	24	17.6
160	110	178	235	218	112	40	314	320	326	380	26	32	24	17.6
185	120	199	260	271	140	45	344	350	356	410	26	32	24	26.5
185	120	199	260	271	140	45	344	350	356	410	26	32	24	26.5
175	120	191	250	242	125	45	344	350	356	410	26	32	24	22.3
175	120	191	250	242	125	45	344	350	356	410	26	32	24	22.3
185	120	199	260	271	140	45	344	350	356	410	26	32	24	26.5
185	120	199	260	271	140	45	344	350	356	410	26	32	24	26.5
190	130	208	265	290	150	50	373	380	387	445	28	35	24	34.0
190	130	208	265	290	150	50	373	380	387	445	28	35	24	34.0
205	150	223	285	302	150	50	413	420	427	500	35	42	30	39.0
205	150	223	285	302	150	50	413	420	427	500	35	42	30	39.0
220	160	241	295	323	160	60	443	450	457	530	35	42	30	48.0
220	160	241	295	323	160	60	443	450	457	530	35	42	30	48.0
235	160	254	315	344	170	60	463	470	477	550	35	42	30	54.5
235	160	254	315	344	170	60	463	470	477	550	35	42	30	54.5

SNT SPHERICAL ROLLER BEARING PLUMMER BLOCKS

FOUR-BOLT FSNT HOUSINGS FOR CYLINDRICAL BORE BEARINGS

FOUR-BOLT FSNT HOUSINGS FOR CYLINDRICAL BORE BEARINGS

- The basic numbers for ordering plummer block housings and components are listed in the table below.
- Each housing includes the housing cap, base and cap bolts.
- Assemblies shown are furnished in cast iron. If cast steel is desired, add the letter S to the alpha prefix (e.g., FSNTS 518).
- If ductile iron is desired, add the letter D to the alpha prefix (e.g., FSNTD 505).
- Seal sleeve for d_a shaft to be supplied by customer and should have same O.D. as d_b .

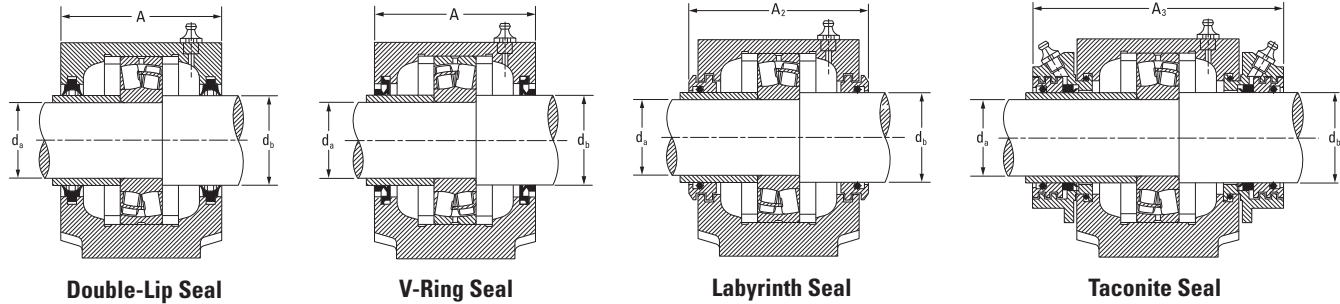

Shaft Dia.		Housing	Bearing	Locating Rings ⁽¹⁾ O.D. x Width	Double-Lip Seal ⁽²⁾	V-Ring Seal ⁽²⁾	Labyrinth Seal ⁽³⁾	Taconite Seal ⁽³⁾	End Cover ⁽³⁾
d_a	d_b								
mm	mm								
35	45	FSNT 208-307	21307	SR80X9	TSNG307	VR307	LO307	TA307	EC510-608
40	50	FSNT 208-307	22208	SR80X8	TSNG208	VR208	LO208	TA208	EC510-608
		FSNT 510-608	21308	SR90X9	TSNG308	VR308	LO308	TA308	EC510-608
		FSNT 510-608	22308	SR90X4	TSNG308	VR308	LO308	TA308	EC510-608
45	55	FSNT 209	22209	SR85X3.5	TSNG209	VR209	LO209	TA209	EC511-609
		FSNT 511-609	21309	SR100X9.5	TSNG309	VR309	LO309	TA309	EC511-609
		FSNT 511-609	22309	SR100X4	TSNG309	VR309	LO309	TA309	EC511-609
50	60	FSNT 210	22210	SR90X9	TSNG210	VR210	LO210	TA210	EC512-610
		FSNT 512-610	21310	SR110X10.5	TSNG310	VR310	LO310	TA310	EC512-610
		FSNT 512-610	22310	SR110X 4	TSNG310	VR310	LO310	TA310	EC512-610
55	65	FSNT 211	22211	SR100X9.5	TSNG211	VR211	LO211	TA211	EC513-611
		FSNT 513-611	21311	SR120X11	TSNG311	VR311	LO311	TA311	EC513-611
		FSNT 513-611	22311	SR120X4	TSNG311	VR311	LO311	TA311	EC513-611
60	70	FSNT 212	22212	SR110X10	TSNG212	VR212	LO212	TA212	EC515-612
		FSNT 515-612	21312	SR130X12.5	TSNG312	VR312	LO312	TA312	EC515-612
		FSNT 515-612	22312	SR130X5	TSNG312	VR312	LO312	TA312	EC515-612
65	75	FSNT 213	22213	SR120X10	TSNG213	VR213	LO213	TA213	EC516-613
		FSNT 516-613	21313	SR140X12.5	TSNG313	VR313	LO313	TA313	EC516-613
		FSNT 516-613	22313	SR140X5	TSNG313	VR313	LO313	TA313	EC516-613
70	80	FSNT 517	22314	SR150X5	TSNG314	VR314	LO314	TA314	EC517
		FSNT 517	21314	SR150X13	TSNG314	VR314	LO314	TA314	EC517
75	85	FSNT 215	22215	SR130X12.5	TSNG215	VR215	LO215	TA215	EC518-615
		FSNT 518-615	21315	SR160X14	TSNG315	VR315	LO315	TA315	EC518-615
		FSNT 518-615	22315	SR160X5	TSNG315	VR315	LO315	TA315	EC518-615
80	90	FSNT 216	22216	SR140X10	TSNG216	VR216	LO216	TA216	EC216
		FSNT 519-616	21316	SR170X14.5	TSNG316	VR316	LO316	TA316	EC519-616
		FSNT 519-616	22316	SR170X5	TSNG316	VR316	LO316	TA316	EC519-616

⁽¹⁾Locating rings = minimum two required for fixed position, sold one piece per box.

⁽²⁾Double-lip and V-ring seal sold two pieces per box. Consult with your Timken engineer for double-lip seal availability.

⁽³⁾Labyrinth, taconite seal and end cover, sold one piece per box.

SNT SPHERICAL ROLLER BEARING PLUMMER BLOCKS

FOUR-BOLT FSNT HOUSINGS FOR CYLINDRICAL BORE BEARINGS

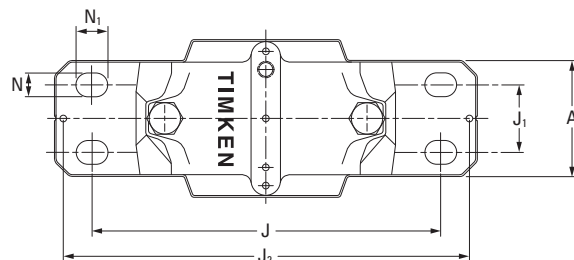
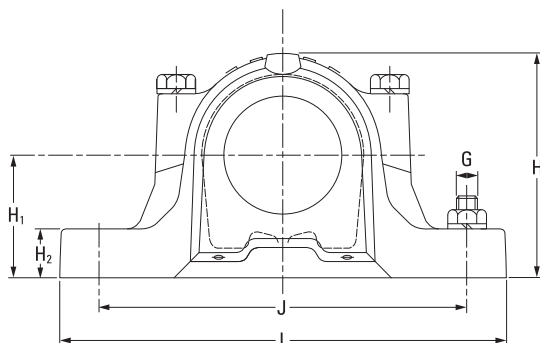

Housing Dimensions													4 Bolts Req'd	Housing Mass
A	A ₁	A ₂	A ₃	H	H ₁	H ₂	J	J ₁	J ₂	L	N	N ₁	G	kg
mm	mm	mm	mm	mm	mm	mm	mm	mm	mm	mm	mm	mm	mm	kg
85	60	99	160	108	60	25	160	34	–	205	11	–	12	2.9
85	60	99	160	108	60	25	160	34	–	205	11	–	12	2.9
90	60	102	150	113	60	25	160	34	–	205	–	11	12	3.2
90	60	102	150	113	60	25	160	34	–	205	–	11	12	3.2
85	60	97	160	109	60	25	160	34	–	205	11	–	12	2.9
95	70	107	155	128	70	28	210	35	–	255	15	20	16	4.5
95	70	107	155	128	70	28	210	35	–	255	15	20	16	4.5
90	60	102	165	113	60	25	160	34	–	205	11	–	12	3.2
105	70	117	165	134	70	30	210	35	–	255	15	20	16	5.3
105	70	117	165	134	70	30	210	35	–	255	15	20	16	5.3
95	70	107	170	128	70	28	200	40	–	255	14	–	16	4.5
110	80	122	170	150	80	30	230	40	–	275	15	20	16	6.6
110	80	122	170	150	80	30	230	40	–	275	15	20	16	6.6
105	70	117	180	134	70	30	200	40	–	255	14	–	16	5.2
115	80	127	175	156	80	30	230	40	–	280	15	20	16	6.9
115	80	127	175	156	80	30	230	40	–	280	15	20	16	6.9
110	80	128	190	149	80	30	220	48	–	275	14	–	16	6.6
120	90	138	180	177	95	32	260	50	–	315	18	24	20	9.7
120	90	138	180	177	95	32	260	50	–	315	18	24	20	9.7
125	90	143	210	183	95	32	260	50	–	320	18	24	20	10.4
125	90	143	210	183	95	32	260	50	–	320	18	24	20	10.4
115	80	133	195	155	80	30	220	48	–	280	14	–	16	6.9
140	100	158	225	194	100	35	290	50	–	345	18	24	20	13.1
140	100	158	225	194	100	35	290	50	–	345	18	24	20	13.1
120	90	138	200	177	95	32	252	52	–	315	18	–	20	9.7
145	100	163	220	212	112	35	290	50	–	345	18	24	20	14.0
145	100	163	220	212	112	35	290	50	–	345	18	24	20	14.0

Continued on next page.

FOUR-BOLT FSNT HOUSINGS FOR CYLINDRICAL BORE BEARINGS – continued

- The basic numbers for ordering plummer block housings and components are listed in the table below.
- Each housing includes the housing cap, base and cap bolts.
- Assemblies shown are furnished in cast iron. If cast steel is desired, add the letter S to the alpha prefix (e.g., FSNTS 518).
- If ductile iron is desired, add the letter D to the alpha prefix (e.g., FSNTD 505).
- Seal sleeve for d_a shaft to be supplied by customer and should have same O.D. as d_b .

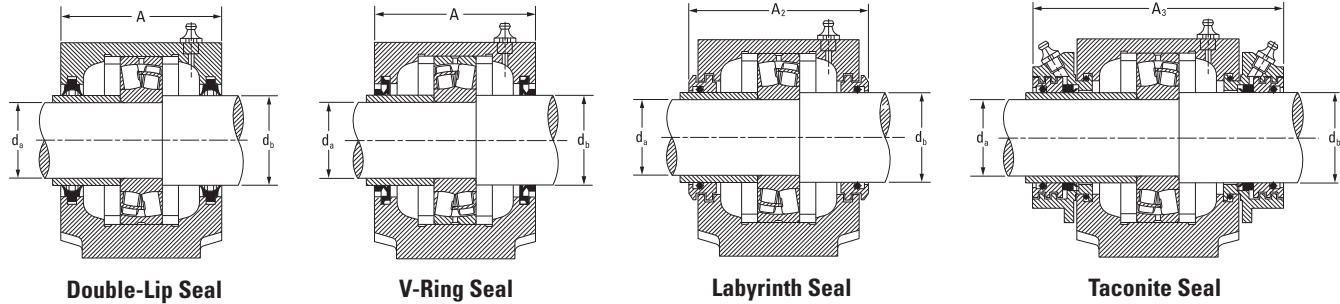

Continued from previous page.

Shaft Dia.		Housing	Bearing	Locating Rings ⁽¹⁾ O.D. x Width	Double-Lip Seal ⁽²⁾	V-Ring Seal ⁽²⁾	Labyrinth Seal ⁽³⁾	Taconite Seal ⁽³⁾	End Cover ⁽³⁾
d_a	d_b								
mm	mm								
85	95	FSNT 217	22217	SR150X12.5	TSNG217	VR217	LO217	TA217	EC217
		FSNT 520-617	21317	SR180X14.5	TSNG317	VR317	LO317	TA317	EC520-617
		FSNT 520-617	22317	SR180X5	TSNG317	VR317	LO317	TA317	EC520-617
90	100	FSNT 218	22218	SR160X12.5	TSNG218	VR218	LO218	TA218	EC218
		FSNT 218	23218	SR160X6.25	TSNG218	VR218	LO218	TA218	EC218
95	110	FSNT 522-619	21319	SR200X17.5	TSNG319	VR219	LO319	TA319	EC522-619
		FSNT 522-619	22319	SR200X6.5	TSNG319	VR219	LO319	TA319	EC522-619
100	115	FSNT 520-617	22220	SR180X12	TSNG220	VR220	LO220	TA220	EC520-617
		FSNT 520-617	23220	SR180X4.85	TSNG220	VR220	LO220	TA220	EC520-617
		FSNT 524-620	21320	SR215X19.5	TSNG320	VR320	LO320	TA320	EC524-620
		FSNT 524-620	22320	SR215X6.5	TSNG320	VR320	LO320	TA320	EC524-620
110	125	FSNT 522-619	22222	SR200X13.5	TSNG222	VR222	LO222	TA222	EC522-619
		FSNT 522-619	23222	SR200X5.1	TSNG222	VR222	LO222	TA222	EC522-619
120	135	FSNT 524-620	22224	SR215X14	TSNG224	VR224	LO224	TA224	EC 524-620
		FSNT 524-620	23224	SR215X5	TSNG224	VR224	LO224	TA224	EC 524-620
130	145	FSNT 526	22226	SR230X13	TSNG226	VR226	LO226	TA226	EC526
		FSNT 526	23226	SR230X5	TSNG226	VR226	LO226	TA226	EC526
140	155	FSNT 528	22228	SR250X15	TSNG228	VR228	LO228	TA228	EC528
		FSNT 528	23228	SR250X5	TSNG228	VR228	LO228	TA228	EC528
150	165	FSNT 530	22230	SR270X16.5	TSNG230	VR230	LO230	TA230	EC530
		FSNT 530	23230	SR270X5	TSNG230	VR230	LO230	TA230	EC530
160	175	FSNT 532	22232	SR290X17	TSNG232	VR232	LO232	TA232	EC532
		FSNT 532	23232	SR290X5	TSNG232	VR232	LO232	TA232	EC532

⁽¹⁾Locating rings = minimum two required for fixed position, sold one piece per box.

⁽²⁾Double-lip and V-ring seal sold two pieces per box. Consult with your Timken engineer for double-lip seal availability.

⁽³⁾Labyrinth, taconite seal and end cover, sold one piece per box.

SNT SPHERICAL ROLLER BEARING PLUMMER BLOCKS

FOUR-BOLT FSNT HOUSINGS FOR CYLINDRICAL BORE BEARINGS

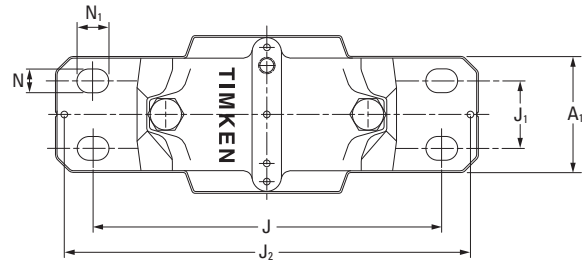
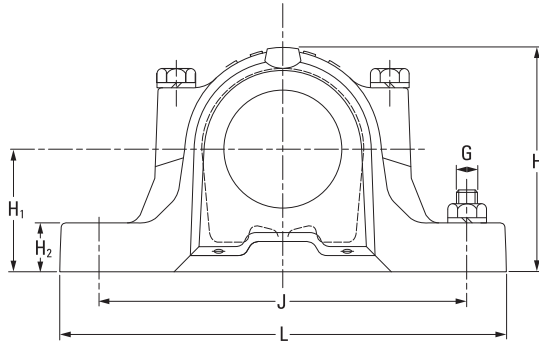

Housing Dimensions													4 Bolts Req'd	Housing Mass
A	A ₁	A ₂	A ₃	H	H ₁	H ₂	J	J ₁	J ₂	L	N	N ₁	G	kg
mm	mm	mm	mm	mm	mm	mm	mm	mm	mm	mm	mm	mm	mm	kg
125	90	143	205	183	95	32	252	52	–	320	18	–	20	10.4
160	110	178	235	218	112	40	320	60	–	380	18	24	24	17.6
160	110	178	235	218	112	40	320	60	–	380	18	24	24	17.6
140	100	158	220	194	100	35	280	58	–	345	18	–	20	13.1
140	100	158	220	194	100	35	280	58	–	345	18	–	20	13.1
175	120	191	250	242	125	45	350	70	–	410	18	24	24	22.3
175	120	191	250	242	125	45	350	70	–	410	18	24	24	22.3
160	110	178	235	218	112	40	320	60	–	380	18	24	24	17.6
160	110	178	235	218	112	40	320	60	–	380	18	24	24	17.6
185	120	199	260	271	140	45	350	70	–	410	18	24	24	26.5
185	120	199	260	271	140	45	350	70	–	410	18	24	24	26.5
175	120	191	250	242	125	45	350	70	–	410	18	24	24	22.3
175	120	191	250	242	125	45	350	70	–	410	18	24	24	22.3
185	120	199	260	271	140	45	350	70	–	410	18	24	24	26.5
185	120	199	260	271	140	45	350	70	–	410	18	24	24	26.5
190	130	208	265	290	150	50	380	70	–	445	22	28	24	34.0
190	130	208	265	290	150	50	380	70	–	445	22	28	24	34.0
205	150	223	285	302	150	50	420	80	–	500	26	32	30	39.0
205	150	223	285	302	150	50	420	80	–	500	26	32	30	39.0
220	160	241	295	323	160	60	450	90	–	530	26	32	30	48.0
220	160	241	295	323	160	60	450	90	–	530	26	32	30	48.0
235	160	254	315	344	170	60	470	90	–	550	26	32	30	54.5
235	160	254	315	344	170	60	470	90	–	550	26	32	30	54.5

LARGE PLUMMER BLOCK HOUSINGS – 3000 AND 3100 SERIES

- The basic numbers for ordering plummer block housings and components are listed in the table below.
- Each housing includes the housing cap, base and cap bolts.
- Housings shown are furnished in cast iron. If cast steel is desired, add the letter S to the alpha prefix (e.g., SNTS 518). If ductile iron is desired, add the letter D to the alpha prefix (e.g., SNTD 505).
- Housings with the F suffix are manufactured for fixed bearings. Those with the L suffix are float position housings.

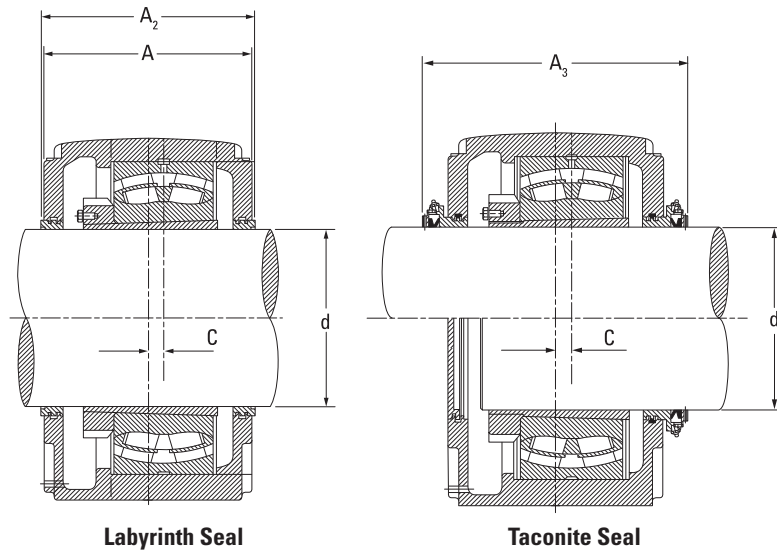

Shaft Dia. d	Housing	Bearing	Locating Rings ⁽¹⁾ O.D. x Width	Quantity (Typically required for this bearing/housing configuration)	Adapter Sleeve ⁽²⁾	Locknut ⁽³⁾	Lockwasher ⁽³⁾	Labyrinth Seal ⁽³⁾	Taconite Seal ⁽³⁾	End Cover ⁽³⁾
mm										
150	SNT 3134	23134K	SR280X10	2	H3134	KM34	MB34	L034	TA34	EC34
160	SNT 3036	23036K	SR280X17	2	H3036	KM36	MB36	L036	TA36	EC36
	SNT 3136	23136K	SR300X10	2	H3136	KM36	MB36	L036	TA36	EC36
170	SNT 3038	23038K	SR290X10	4	H3038	KML38	MBL38	L038	TA38	EC38
	SNT 3138	23138K	SR320X10	2	H3138	KM38	MB38	L038	TA38	EC38
180	SNT 3040	23040K	SR310X10	4	H3040	KM40	MB40	L040	TA40	EC40
	SNT 3140	23140K	SR340X10	2	H3140	KM40	MB40	L040	TA40	EC40
200	SNT 3044	23044K	SR340X10	4	OH3044H	HM3044	MS3044	L044	TA44	EC44
	SNT 3144	23144K	SR370X10	2	OH3144H	HM44T	MB44	L044	TA44	EC44
220	SNT 3048	23048K	SR360X12	4	OH3048H	HM3048	MS3048	L048	TA48	EC48
	SNT 3148	23148K	SR400X10	2	OH3148H	HM48T	MB48	L048	TA48	EC48
240	SNT 3052	23052K	SR400X22	2	OH3052H	HM3052	MS3052	L052	TA52	EC52
	SNT 3152	23152K	SR440X10	2	OH3152H	HM52T	MB52	L052	TA52	EC52
260	SNT 3056	23056K	SR420X10	6	OH3056H	HM3056	MS3056	L056	TA56	EC56
	SNT 3156	23156K	SR460X10	2	OH3156H	HM56T	MB56	L056	TA56	EC56
280	SNT 3060	23060K	SR460X25	2	OH3060H	HM3060	MS3060	L060	TA60	EC60
	SNT 3160	23160K	SR500X10	2	OH3160H	HM3160	MS3160	L060	TA60	EC60
300	SNT 3064	23064K	SR480X10	6	OH3064H	HM3064	MS3064	L064	TA64	EC64
	SNT 3164	23164K	SR540X10	2	OH3164H	HM3164	MS3164	L064	TA64	EC64
320	SNT 3068	23068K	SR520X16	4	OH3068H	HM3068	MS3068	L068	TA68	EC68
	SNT 3168F	23168K	FIXED HOUSING	–	OH3168H	HM3168	MS3168	L068	TA68	EC68
	SNT 3168L	23168K	FLOAT HOUSING	–	OH3168H	HM3168	MS3168	L068	TA68	EC68
340	SNT 3072	23172K	SR540X16	4	OH3072H	HM3072	MS3072	L072	TA72	EC72
	SNT 3172F	23172K	FIXED HOUSING	–	OH3172H	HM3172	MS3172	L072	TA72	EC72
	SNT 3172L	23172K	FLOAT HOUSING	–	OH3172H	HM3172	MS3172	L072	TA72	EC72

⁽¹⁾Locating rings = minimum two required for fixed position, sold one piece per box.

⁽²⁾Adapter sleeve assembly includes one sleeve, one locknut and one lockwasher.

⁽³⁾Labyrinth, taconite seal, end cover, locknut, lockwasher, sold one piece per box.

SNT SPHERICAL ROLLER BEARING PLUMMER BLOCKS

LARGE PLUMMER BLOCK HOUSINGS – 3000 AND 3100 SERIES

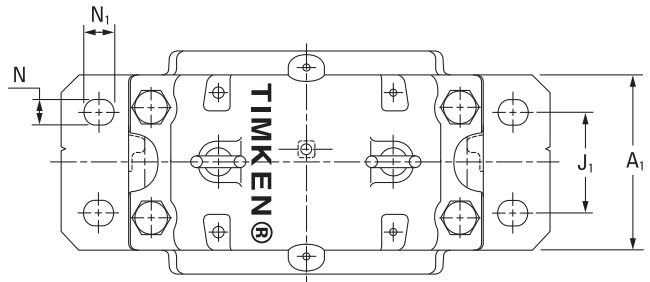
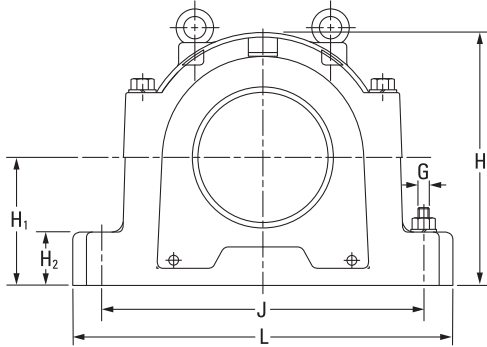

Housing Dimensions													4 Bolts Req'd	Housing Mass
A	A ₁	A ₂	A ₃	C	H	H ₁	H ₂	J	J ₁	L	N	N ₁	G	kg
mm	mm	mm	mm	mm	mm	mm	mm	mm	mm	mm	mm	mm	mm	kg
230	180	240	300	14	333	170	70	430	100	510	28	34	24	75
230	180	240	310	14	333	170	70	430	100	510	28	34	24	72
240	190	250	315	15	353	180	75	450	110	530	28	34	24	92
240	190	250	315	15	353	180	75	450	110	530	28	34	24	81
260	210	270	335	10	375	190	80	480	120	560	28	34	24	112
260	210	270	335	10	375	190	80	480	120	560	28	34	24	110
280	230	290	355	10	411	210	85	510	130	610	35	42	30	130
280	230	290	355	12	434	220	90	540	140	640	35	42	30	118
290	240	300	365	12	434	240	95	600	150	700	35	42	30	140
290	240	300	365	12	474	240	95	600	150	700	35	42	30	138
310	260	315	400	12	474	260	100	650	160	770	35	42	30	193
310	260	315	400	12	474	260	100	650	160	770	35	42	30	189
320	280	330	415	13	516	260	105	670	160	790	42	50	36	235
320	280	330	415	13	516	260	105	670	160	790	42	50	36	254
320	280	330	415	16	551	280	110	710	160	830	42	50	36	260
320	280	330	415	16	551	300	110	710	190	830	42	50	36	310
350	310	360	445	22	591	300	115	750	190	880	42	50	36	300
350	310	360	445	23	631	320	115	750	200	880	42	50	36	346
370	330	380	465	23	631	320	115	750	200	880	42	50	36	339
400	360	410	492	24	675	340	120	810	220	950	42	50	36	432.5
400	360	410	492	24	675	340	120	810	220	950	42	50	36	429.5
370	330	380	465	23	631	320	115	750	200	950	42	50	36	342
400	360	410	492	30	695	350	120	840	220	1000	42	50	36	458
400	360	410	492	30	695	350	120	840	220	1000	42	50	36	454

Continued on next page.

LARGE PLUMMER BLOCK HOUSINGS – 3000 AND 3100 SERIES – continued

- The basic numbers for ordering plummer block housings and components are listed in the table below.
- Each housing includes the housing cap, base and cap bolts.
- Housings shown are furnished in cast iron. If cast steel is desired, add the letter S to the alpha prefix (e.g., SNTS 518). If ductile iron is desired, add the letter D to the alpha prefix (e.g., SNTD 505).
- Housings with the F suffix are manufactured for fixed bearings. Those with the L suffix are float position housings.

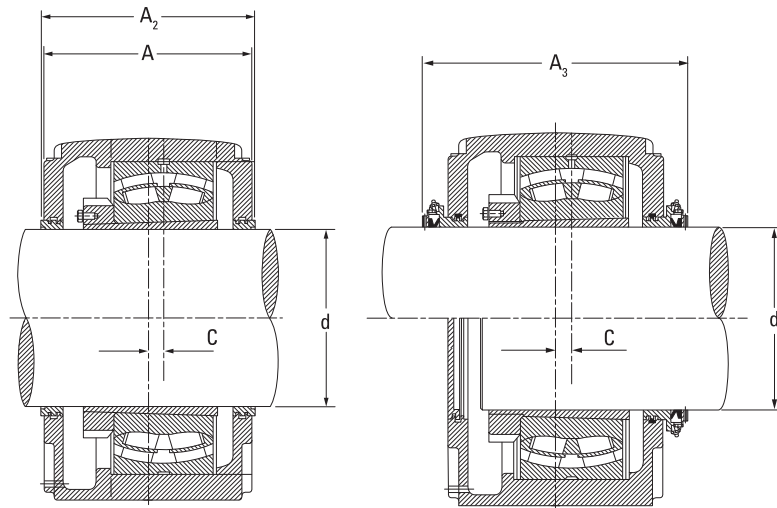

Continued from previous page.

Shaft Dia. d	Housing	Bearing	Locating Rings ⁽¹⁾ O.D. x Width	Quantity (Typically required for this bearing/housing configuration)	Adapter Sleeve ⁽²⁾	Locknut ⁽³⁾	Lockwasher ⁽³⁾	Labyrinth Seal ⁽³⁾	Taconite Seal ⁽³⁾	End Cover ⁽³⁾
mm										
360	SNT 3076F	23076K	FIXED HOUSING	-	OH3076H	HM3076	MS3076	L076	TA76	EC76
	SNT 3076L	23076K	FLOAT HOUSING		OH3076H	HM3076	MS3076	L076	TA76	EC76
	SNT 3176F	23176K	FIXED HOUSING		OH3176H	HM3176	MS3176	L076	TA76	EC76
	SNT 3176L	23176K	FLOAT HOUSING		OH3176H	HM3176	MS3176	L076	TA76	EC76
380	SNT 3080F	23080K	FIXED HOUSING	-	OH3080H	HM3080	MS3080	L080	TA80	EC80
	SNT 3080L	23080K	FLOAT HOUSING		OH3080H	HM3080	MS3080	L080	TA80	EC80
	SNT 3180F	23180K	FIXED HOUSING		OH3180H	HM3180	MS3180	L080	TA80	EC80
	SNT 3180L	23180K	FLOAT HOUSING		OH3180H	HM3180	MS3180	L080	TA80	EC80
400	SNT 3084F	23084K	FIXED HOUSING	-	OH3084H	HM3084	MS3084	L084	TA84	EC84
	SNT 3084L	23084K	FLOAT HOUSING		OH3084H	HM3084	MS3084	L084	TA84	EC84

⁽¹⁾Locating rings = minimum two required for fixed position, sold one piece per box.

⁽²⁾Adapter sleeve assembly includes one sleeve, one locknut and one lockwasher.

⁽³⁾Labyrinth, taconite seal, end cover, locknut, lockwasher, sold one piece per box.

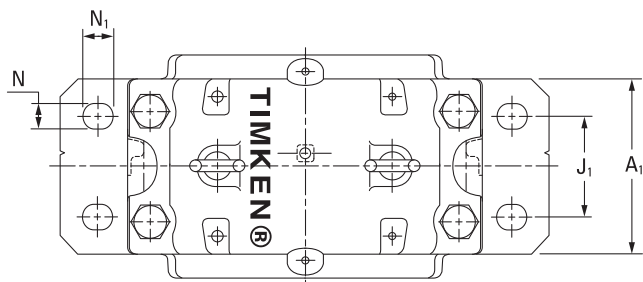
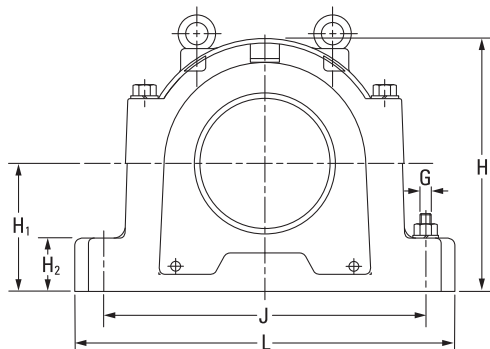

Housing Dimensions													4 Bolts Req'd	Housing Mass
A	A ₁	A ₂	A ₃	C	H	H ₁	H ₂	J	J ₁	L	N	N ₁	G	
400	360	410	495	24	675	340	120	810	220	1000	42	50	36	430
400	360	410	495	24	675	340	120	810	220	1000	42	50	36	427
400	360	410	492	30	715	360	120	870	220	1040	42	50	36	487
400	360	410	492	30	715	360	120	870	220	1040	42	50	36	484
400	360	410	495	30	695	350	120	840	220	1040	42	50	36	454
400	360	410	495	30	695	350	120	840	220	1040	42	50	36	450
430	390	440	522	30	775	380	125	950	240	1120	48	60	42	595
430	390	440	522	30	775	380	125	950	240	1120	48	60	42	595
400	360	410	495	30	715	360	120	870	220	1120	42	50	36	483
400	360	410	495	30	715	360	120	870	220	1120	42	50	36	480

METRIC SHAFT DIAMETERS

TABLE 20. SUGGESTED METRIC SHAFT DIAMETERS FOR USE WITH ADAPTER SLEEVES (MM)

Shaft O.D.	Max.	Min.	Shaft O.D.	Max.	Min.
20	20.000	19.925	190	190.000	189.875
25	25.000	24.925	200	200.000	199.875
30	30.000	29.925	210	210.000	209.850
35	35.000	34.925	220	220.000	219.850
40	40.000	39.925	230	230.000	229.850
45	45.000	44.925	240	240.000	239.850
50	50.000	49.925	250	250.000	249.850
55	55.000	54.900	260	260.000	259.850
60	60.000	59.900	270	270.000	269.825
65	65.000	64.900	280	280.000	279.825
70	70.000	69.900	290	290.000	289.825
75	75.000	74.900	300	300.000	299.825
80	80.000	79.900	310	310.000	309.825
85	85.000	84.900	320	320.000	319.800
90	90.000	89.900	330	330.000	329.800
95	95.000	94.900	340	340.000	339.800
100	100.000	99.900	350	350.000	349.800
105	105.000	104.875	360	360.000	359.800
110	110.000	109.875	370	370.000	369.800
115	115.000	114.875	380	380.000	379.800
120	120.000	119.875	390	390.000	389.800
125	125.000	124.875	400	400.000	399.800
130	130.000	129.875	410	410.000	409.800
135	135.000	134.875	420	420.000	419.800
140	140.000	139.875	430	430.000	429.800
145	145.000	144.875	440	440.000	439.800
150	150.000	149.875	450	450.000	449.800
160	160.000	159.875	460	460.000	459.800
170	170.000	169.875	470	470.000	469.800
180	180.000	179.875	480	480.000	479.800

SPHERICAL ROLLER BEARING PRODUCT DATA TABLES

Timken® spherical roller bearings feature all of the characteristics that have made Timken renowned – superior design, reliable performance and comprehensive technical support. Spherical roller bearings are designed to manage high radial loads and perform consistently, even when misalignment, marginal lubrication, contamination, extreme speeds and critical application stresses are present.

Nomenclature.....	84
Spherical Roller Bearing Product Data Tables	85



SPHERICAL ROLLER BEARING NOMENCLATURE

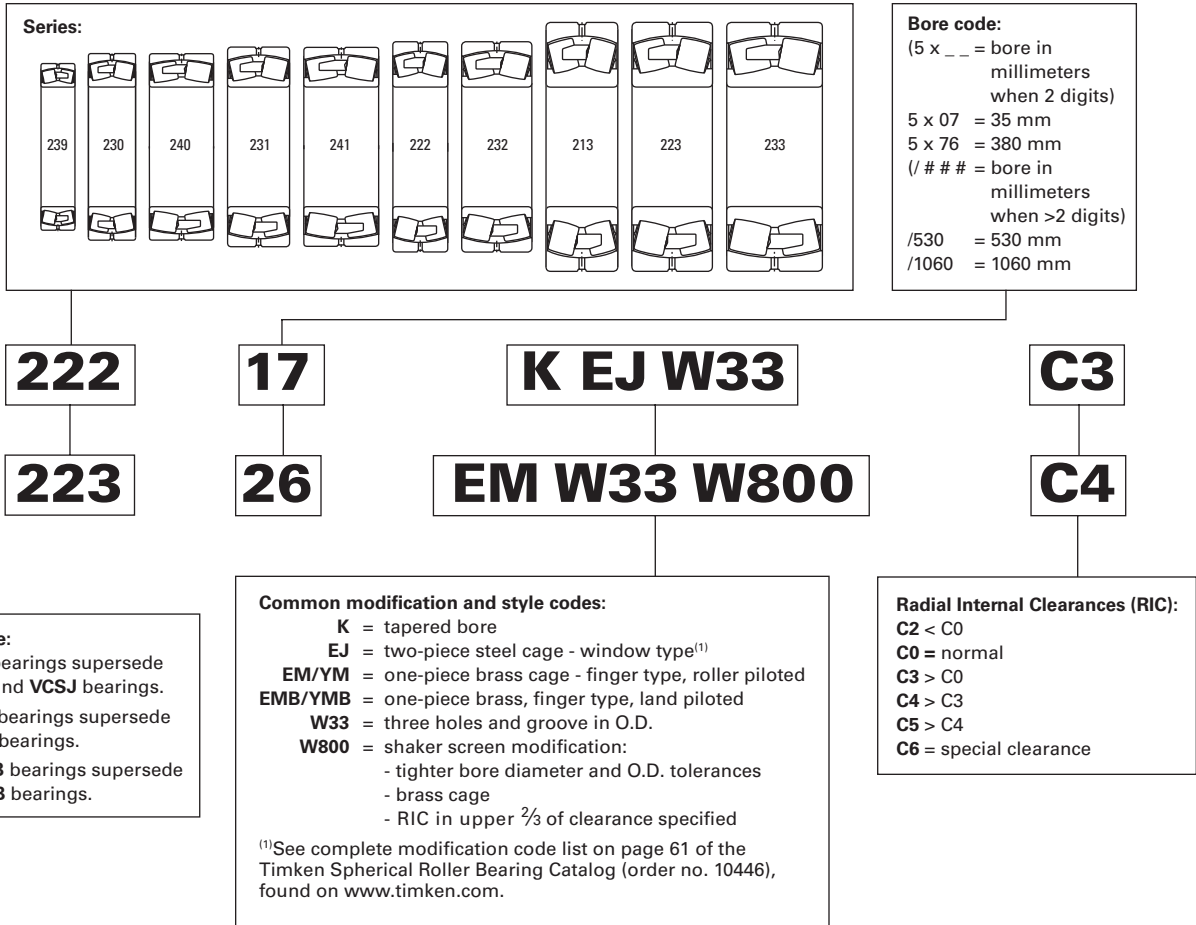
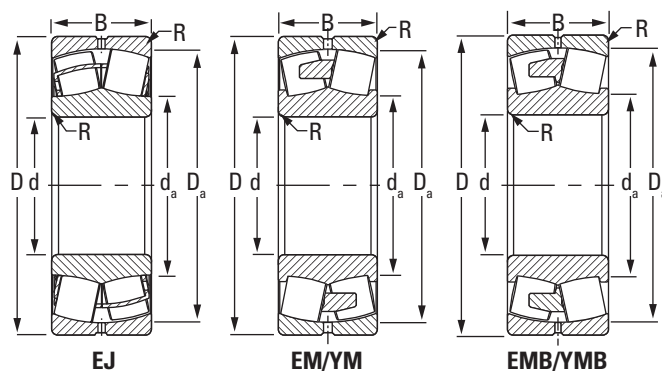

Fig. 35. Timken® spherical roller bearing nomenclature.

213 SERIES (200, 300, 500, 600 SERIES SNT, FSNT)

- Bearings are available with a tapered bore for adapter-type mounting. To order, add the suffix K to bearing number (e.g., 23120K).
- Consult your Timken engineer and www.timken.com for up-to-date information about the availability of the bearings you have selected.
- This section lists spherical roller bearings pertinent to Timken SNT plummer blocks. For a wider selection, consult www.timken.com or the Timken® Spherical Roller Bearing catalog (order no. 10446).



Bearing Part No.	Bearing Dimensions			Load Ratings		Cage Type	Mounting Data			Equivalent Radial Load Factors ⁽²⁾				Geometry Factor ⁽³⁾	Thermal Speed Ratings ⁽⁴⁾		Wt.
							Fillet ⁽¹⁾ (Max.)	Backing Dia.		Dynamic		Static	Oil		Grease		
	R	Shaft d _a	Housing D _a	$\frac{F_a}{F_r} \leq e$ X = 1	$\frac{F_a}{F_r} > e$ X = 0.67			In All Cases	RPM	RPM							
	mm in.	mm in.	mm in.	kN lbf.	kN lbf.		mm in.	mm in.	mm in.	e	Y	Y	Y ₀		C _g	RPM	
21305	25 0.9843	62 2.4409	17 0.6693	55.5 12500	44.3 9970	EJ	1 0.04	35 1.4	55 2.1	0.27	2.48	3.7	2.43	0.037	10000	8100	0.3 0.7
21306	30 1.1811	72 2.8346	19 0.748	70.3 15800	56.5 12700	EJ	1 0.04	41 1.6	64 2.5	0.26	2.6	3.87	2.54	0.041	8900	7200	0.4 0.9
21307	35 1.378	80 3.1496	21 0.8268	90.2 20300	77.8 17500	EJ	1.5 0.06	47 1.9	71 2.8	0.26	2.56	3.81	2.5	0.044	7900	6400	0.5 1.1
21308	40 1.5748	90 3.5433	23 0.9055	113 25400	102 22900	EJ	1.5 0.06	54 2.1	80 3.2	0.26	2.64	3.93	2.58	0.048	7100	5800	0.7 1.5
21309	45 1.7717	100 3.937	25 0.9843	138 31000	125 28200	EJ	1.5 0.06	60 2.4	90 3.5	0.25	2.75	4.09	2.69	0.052	6500	5300	1.0 2.2
21310	50 1.9685	110 4.3307	27 1.063	163 36700	151 33800	EJ	2 0.08	67 2.6	99 3.9	0.24	2.83	4.21	2.76	0.055	5900	4900	1.2 2.6
21311	55 2.1654	120 4.7244	29 1.1417	188 42400	176 39500	EJ	2 0.08	73 2.9	108 4.2	0.24	2.81	4.18	2.75	0.058	5500	4500	1.6 3.5
21312	60 2.3622	130 5.1181	31 1.2205	225 50500	219 49200	EJ	2 0.08	80 3.2	116 4.6	0.23	2.91	4.33	2.84	0.062	5100	4200	2.0 4.4
21313	65 2.5591	140 5.5118	33 1.2992	259 58200	254 57100	EJ	2 0.08	86 3.4	126 5	0.23	2.94	4.37	2.87	0.065	4800	3900	2.4 5.3
21314	70 2.7559	150 5.9055	35 1.378	292 65600	289 65000	EJ	2 0.08	93 3.7	135 5.3	0.23	2.97	4.42	2.9	0.068	4500	3700	3.0 6.6
21315	75 2.9528	160 6.2992	37 1.4567	322 72400	321 72200	EJ	2 0.08	99 3.9	144 5.7	0.23	2.98	4.43	2.91	0.071	4300	3600	3.5 7.7
21316	80 3.1496	170 6.6929	39 1.5354	363 81700	363 81700	EJ	2 0.08	105 4.1	153 6	0.22	3.01	4.47	2.94	0.073	4100	3400	4.2 9.2
21317	85 3.3465	180 7.0866	41 1.6142	403 90600	407 91500	EJ	2.5 0.1	112 4.4	162 6.4	0.22	3.04	4.53	2.97	0.076	3900	3200	4.9 10.8
21318	90 3.5433	190 7.4803	43 1.6929	442 99400	449 101000	EJ	2.5 0.1	118 4.7	171 6.7	0.22	3.05	4.55	2.99	0.079	3700	3100	5.8 12.8

⁽¹⁾Maximum shaft or housing fillet radius that bearing corners will clear.

⁽²⁾These factors apply for both inch and metric calculations. See engineering section for instructions on use.

⁽³⁾Geometry constant for Lubrication Life Factor a₃ is found in the Bearing Ratings section of the Engineering Manual (order no. 10424).

⁽⁴⁾See thermal speed ratings in the Engineering Manual (order no. 10424).

NOTE: Where EJ and EM/EMB have different load ratings, the more conservative one was taken to use for both assemblies.

NOTE: Tolerance and shaft diameters are shown in tables 2 and 3 on pages 19 and 20 as variances from nominal bearing bore.

222 SERIES (200, 500 SERIES SNT, FSNT)

- Bearings are available with a tapered bore for adapter-type mounting. To order, add the suffix K to bearing number (e.g., 23120K).
- Consult your Timken engineer and www.timken.com for up-to-date information about the availability of the bearings you have selected.
- This section lists spherical roller bearings pertinent to Timken SNT plummer blocks. For a wider selection, consult www.timken.com or the Timken® Spherical Roller Bearing catalog (order no. 10446).

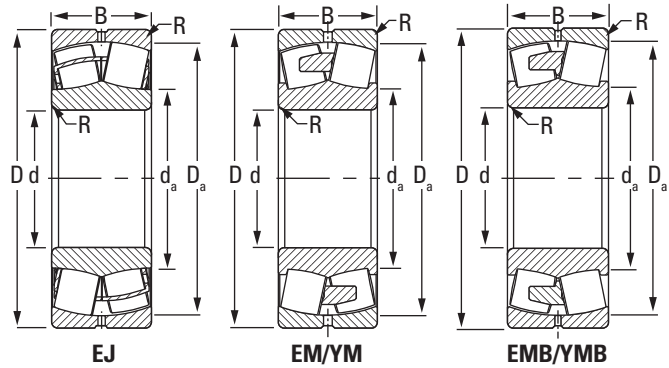

Bearing Part No.	Bearing Dimensions			Load Ratings		Cage Type	Mounting Data			Equivalent Radial Load Factors ⁽²⁾				Geometry Factor ⁽³⁾	Thermal Speed Ratings ⁽⁴⁾		Wt.
							Fillet ⁽¹⁾ (Max.)	Backing Dia.		e	Dynamic		Static		Oil	Grease	
	R	Shaft d _a	Housing D _a	$\frac{F_a}{F_r} \leq e$ X = 1	$\frac{F_a}{F_r} > e$ X = 0.67			In All Cases	RPM		RPM						
	mm in.	mm in.	mm in.	kN lbf.	kN lbf.		mm in.	mm in.	mm in.		Y	Y	Y ₀		C _g		
22205	25 0.9843	52 2.0472	18 0.7087	50.6 11400	43.1 9690	EJ	1 0.04	30 1.2	47 1.9	0.34	2	2.98	1.96	0.032	12000	9200	0.2 0.4
22206	30 1.1811	62 2.4409	20 0.7874	67.4 15200	60.8 13700	EJ	1 0.04	38 1.5	56 2.2	0.31	2.15	3.2	2.1	0.037	9700	7800	0.3 0.7
22207	35 1.378	72 2.8346	23 0.9055	90.5 20300	88 19700	EJ	1 0.04	45 1.8	65 2.6	0.31	2.21	3.29	2.16	0.041	8600	6900	0.5 1.1
22208	40 1.5748	80 3.1496	23 0.9055	104 23400	99.7 22400	EJ/EM	1 0.04	50 2	73 2.9	0.27	2.47	3.67	2.41	0.044	7500	6000	0.6 1.3
22209	45 1.7717	85 3.3465	23 0.9055	104 23500	101 22800	EJ/EM	1 0.04	55 2.2	77 3	0.26	2.64	3.93	2.58	0.046	6800	5500	0.6 1.3
22210	50 1.9685	90 3.5433	23 0.9055	112 25200	112 25100	EJ/EM	1 0.04	59 2.3	82 3.2	0.24	2.84	4.23	2.78	0.049	6200	5000	0.6 1.3
22211	55 2.1654	100 3.937	25 0.9843	134 30100	134 30100	EJ/EM	1.5 0.06	66 2.6	91 3.6	0.23	2.95	4.4	2.89	0.052	5800	4700	0.9 2.0
22212	60 2.3622	110 4.3307	28 1.1024	163 36600	164 36900	EJ/EM	1.5 0.06	72 2.8	100 4	0.24	2.84	4.23	2.78	0.055	5500	4400	1.2 2.6
22213	65 2.5591	120 4.7244	31 1.2205	198 44600	204 45900	EJ/EM	1.5 0.06	78 3.1	109 4.3	0.24	2.79	4.15	2.73	0.058	5100	4200	1.6 3.5
22214	70 2.7559	125 4.9213	31 1.2205	205 46000	219 49200	EJ/EM	1.5 0.06	84 3.3	114 4.5	0.23	2.9	4.32	2.84	0.063	4800	3900	1.6 3.5
22215	75 2.9528	130 5.1181	31 1.2205	222 49900	240 54100	EJ	1.5 0.06	88 3.5	120 4.7	0.22	3.14	4.67	3.07	0.062	4600	3700	1.7 3.7
22216	80 3.1496	140 5.5118	33 1.2992	254 57200	278 62500	EJ/EM	2 0.08	95 3.7	129 5.1	0.22	3.14	4.67	3.07	0.065	4300	3500	2.2 4.8

⁽¹⁾Maximum shaft or housing fillet radius that bearing corners will clear.

⁽²⁾These factors apply for both inch and metric calculations. See Timken Engineering Manual (order no. 10424) for instructions on use.

⁽³⁾Geometry constant for Lubrication Life Factor a_{31} is found in the Bearing Ratings section of the Engineering Manual (order no. 10424).

⁽⁴⁾See thermal speed ratings in the Engineering Manual (order no. 10424).

NOTE: Where EJ and EM/EMB have different load ratings, the more conservative one was taken to use for both assemblies.

NOTE: Tolerance and shaft diameters are shown in tables 2 and 3 on pages 19 and 20 as variances from nominal bearing bore.

Continued on next page.

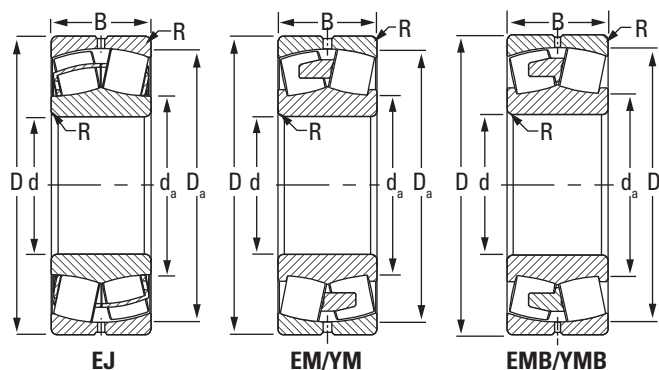

Continued from previous page.

Bearing Part No.	Bearing Dimensions			Load Ratings		Cage Type	Mounting Data			Equivalent Radial Load Factors ⁽²⁾				Geometry Factor ⁽³⁾	Thermal Speed Ratings ⁽⁴⁾		Wt.
							Fillet ⁽¹⁾ (Max.)	Backing Dia.		Dynamic		Static	Oil		Grease		
	R	Shaft d _a	Housing D _a	$\frac{F_a}{F_r} \leq e$ X = 1	$\frac{F_a}{F_r} > e$ X = 0.67			In All Cases	RPM	RPM							
	mm in.	mm in.	mm in.	kN lbf.	kN lbf.		mm in.	mm in.	mm in.	e	Y	Y	Y ₀		C _g	RPM	
22217	85 3.3465	150 5.9055	36 1.4173	286 64200	302 67900	EJ/EM	2 0.08	101 4	139 5.5	0.22	3.07	4.57	3	0.068	4200	3400	2.7 5.9
22218	90 3.5433	160 6.2992	40 1.5748	355 79700	388 87200	EJ/EM	2 0.08	105 4.2	146 5.8	0.23	2.9	4.31	2.83	0.07	4000	3300	3.5 7.7
22219	95 3.7402	170 6.6929	43 1.6929	385 86600	441 99000	EJ/EM	2 0.08	114 4.5	155 6.1	0.23	2.88	4.29	2.82	0.076	3900	3200	4.2 9.2
22220	100 3.937	180 7.0866	46 1.811	435 97700	502 113000	EJ/EM	2 0.08	120 4.7	163 6.4	0.24	2.85	4.24	2.78	0.079	3800	3100	5.0 11.0
22222	110 4.3307	200 7.874	53 2.0866	555 125000	653 147000	EJ/EM	2 0.08	133 5.2	182 7.2	0.25	2.73	4.06	2.67	0.084	3500	2900	7.2 15.8
22224	120 4.7244	215 8.4646	58 2.2835	647 145000	772 174000	EJ/EM	2 0.08	143 5.6	196 7.7	0.25	2.7	4.02	2.64	0.081	3200	2600	9.0 19.8
22226	130 5.1181	230 9.0551	64 2.5197	757 170000	945 212000	EJ/EM	2.5 0.1	155 6.1	210 8.3	0.26	2.62	3.9	2.56	0.079	2900	2400	11.3 24.9
22228	140 5.5118	250 9.8425	68 2.6772	863 194000	1060 237000	EJ/EM	2.5 0.1	167 6.6	228 9	0.25	2.67	3.98	2.61	0.082	2600	2200	14.2 31.2
22230	150 5.9055	270 10.6299	73 2.874	1000 225000	1230 276000	EJ/EM	2.5 0.1	179 7	246 9.7	0.25	2.69	4	2.63	0.087	2400	2000	17.8 39.2
22232	160 6.2992	290 11.4173	80 3.1496	1170 263000	1450 326000	EJ/EM	2.5 0.1	192 7.5	264 10.4	0.26	2.62	3.91	2.57	0.09	2200	1800	23.0 50.6

⁽¹⁾Maximum shaft or housing fillet radius that bearing corners will clear.

⁽²⁾These factors apply for both inch and metric calculations. See engineering section for instructions on use.

⁽³⁾Geometry constant for Lubrication Life Factor a₃ is found in the Bearing Ratings section of the Engineering Manual (order no. 10424).

⁽⁴⁾See thermal speed ratings in the Engineering Manual (order no. 10424).

NOTE: Where EJ and EM/EMB have different load ratings, the more conservative one was taken to use for both assemblies.

NOTE: Tolerance and shaft diameters are shown in tables 2 and 3 on pages 19 and 20 as variances from nominal bearing bore.

SNT SPLIT PLUMMER BLOCKS

SPHERICAL ROLLER BEARING PRODUCT DATA TABLES • 223 SERIES (500, 600 SERIES SNT, FSNT)

223 SERIES (500, 600 SERIES SNT, FSNT)

- Bearings are available with a tapered bore for adapter-type mounting. To order, add the suffix K to bearing number (e.g., 23120K).
- Consult your Timken engineer and www.timken.com for up-to-date information about the availability of the bearings you have selected.
- This section lists spherical roller bearings pertinent to Timken SNT plummer blocks. For a wider selection, consult www.timken.com or the Timken® Spherical Roller Bearing catalog (order no. 10446).

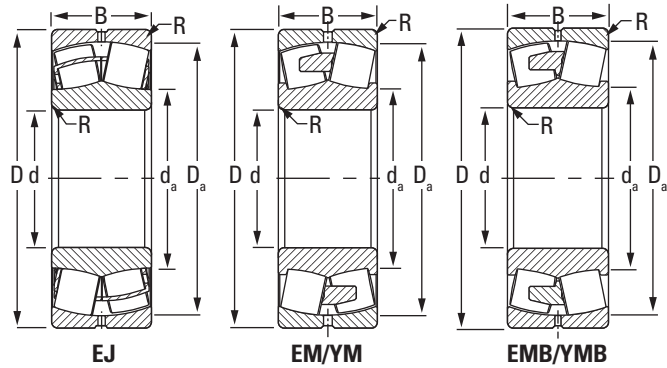

Bearing Part No.	Bearing Dimensions			Load Ratings		Cage Type	Mounting Data			Equivalent Radial Load Factors ⁽²⁾				Geometry Factor ⁽³⁾	Thermal Speed Ratings ⁽⁴⁾		Wt.
							Fillet ⁽¹⁾ (Max.)	Backing Dia.		Dynamic		Static	Thermal Speed Ratings ⁽⁴⁾				
	R	Shaft	Housing	$\frac{F_a}{F_r} \leq e$ X = 1	$\frac{F_a}{F_r} > e$ X = 0.67			In All Cases	Oil	Grease							
	Bore d	O.D. D	Width B	Dynamic C	Static C ₀		R	d _a	D _a	e	Y	Y	Y ₀	C _g	RPM	RPM	kg lbs.
22308	40 1.5748	90 3.5433	33 1.2992	155 34900	147 33100	EJ/EM	1.5 0.06	53 2.1	81 3.2	0.36	1.87	2.79	1.83	0.046	6700	5600	1.0 2.2
22309	45 1.7717	100 3.937	36 1.4173	190 42700	182 40800	EJ/EM	1.5 0.06	58 2.3	90 3.5	0.36	1.9	2.83	1.86	0.049	6100	5100	1.3 2.9
22310	50 1.9685	110 4.3307	40 1.5748	238 53500	241 54200	EJ/EM	2 0.08	65 2.6	98 3.9	0.36	1.89	2.81	1.85	0.055	5500	4600	1.9 4.2
22311	55 2.1654	120 4.7244	43 1.6929	279 62800	284 63800	EJ/EM	2 0.08	69 2.7	106 4.2	0.36	1.89	2.81	1.84	0.057	5100	4300	2.4 5.3
22312	60 2.3622	130 5.1181	46 1.811	321 72200	329 73900	EJ/EM	2 0.08	77 3	117 4.6	0.34	1.98	2.94	1.93	0.061	4700	4000	3.0 6.6
22313	65 2.5591	140 5.5118	48 1.8898	361 81300	371 83300	EJ/EM	2 0.08	84 3.3	127 5	0.33	2.05	3.05	2	0.064	4400	3800	3.6 7.9
22314	70 2.7559	150 5.9055	51 2.0079	395 88800	414 93100	EJ/EM	2 0.08	91 3.6	135 5.3	0.33	2.07	3.08	2.02	0.067	4200	3600	4.4 9.7
22315	75 2.9528	160 6.2992	55 2.1654	450 101000	478 107000	EJ/EM	2 0.08	97 3.8	144 5.7	0.33	2.04	3.04	2	0.071	3900	3300	5.4 11.9
22316	80 3.1496	170 6.6929	58 2.2835	499 112000	534 120000	EJ/EM	2 0.08	103 4.1	153 6	0.33	2.06	3.06	2.01	0.073	3700	3200	6.4 14.1
22317	85 3.3465	180 7.0866	60 2.3622	569 128000	623 140000	EJ/EM	2.5 0.1	110 4.3	162 6.4	0.32	2.11	3.14	2.06	0.076	3500	3000	7.5 16.5
22318	90 3.5433	190 7.4803	64 2.5197	634 143000	703 158000	EJ/EM	2.5 0.1	116 4.6	171 6.7	0.32	2.09	3.11	2.04	0.079	3300	2800	8.8 19.4
22319	95 3.7402	200 7.874	67 2.6378	694 156000	774 174000	EJ/EM	2.5 0.1	122 4.8	180 7.1	0.32	2.1	3.13	2.05	0.082	3000	2600	10.2 22.4
22320	100 3.937	215 8.4646	73 2.874	779 175000	856 193000	EJ/EM	2.5 0.1	130 5.1	193 7.6	0.33	2.06	3.07	2.02	0.072	2800	2400	12.8 28.2

⁽¹⁾Maximum shaft or housing fillet radius that bearing corners will clear.

⁽²⁾These factors apply for both inch and metric calculations. See engineering section for instructions on use.

⁽³⁾Geometry constant for Lubrication Life Factor a_{ij} is found in the Bearing Ratings section of the Engineering Manual (order no. 10424).

⁽⁴⁾See thermal speed ratings in the Engineering Manual (order no. 10424).

NOTE: Where EJ and EM/EMB have different load ratings, the more conservative one was taken to use for both assemblies.

NOTE: Tolerance and shaft diameters are shown in tables 2 and 3 on pages 19 and 20 as variances from nominal bearing bore.

230 SERIES (3000 SERIES SNT, FSNT)

- Bearings are available with a tapered bore for adapter-type mounting. To order, add the suffix K to bearing number (e.g., 23120K).
- Consult your Timken engineer and www.timken.com for up-to-date information about the availability of the bearings you have selected.
- This section lists spherical roller bearings pertinent to Timken SNT plummer blocks. For a wider selection, consult www.timken.com or the Timken® Spherical Roller Bearing catalog (order no. 10446).

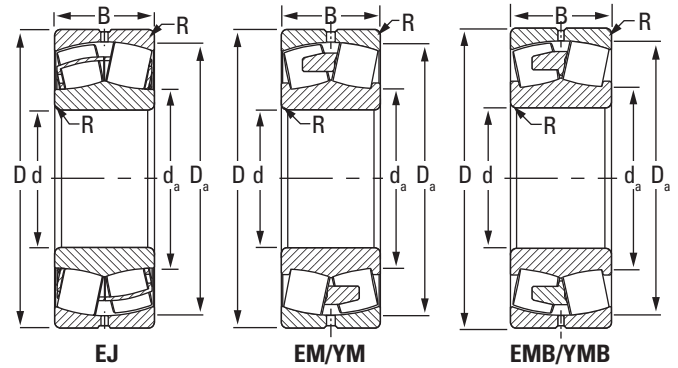

Bearing Part No.	Bearing Dimensions			Load Ratings		Cage Type	Mounting Data			Equivalent Radial Load Factors ⁽²⁾				Geometry Factor ⁽³⁾	Thermal Speed Ratings ⁽⁴⁾		Wt.
							Fillet ⁽¹⁾ (Max.)	Backing Dia.		e	F _a /F _r ≤ e X = 1	F _a /F _r > e X = 0.67	Static In All Cases Y ₀		C ₉	Oil	
	R	Shaft d _a	Housing D _a	Dynamic	Static			RPM	RPM								
	Bore d	O.D. D	Width B	Dynamic C	Static C ₀		mm in.	mm in.	mm in.								kg lbs.
23036	180 7.0866	280 11.0236	74 2.9134	1020 229000	1480 332000	EJ/EM	2 0.08	204 8	260 10.2	0.23	2.91	4.34	2.85	0.093	2000	1700	16.8 37.0
23038	190 7.4803	290 11.4173	75 2.9528	1060 239000	1580 355000	EJ/EM	2 0.08	214 8.4	270 10.6	0.23	3	4.47	2.93	0.096	1900	1600	17.8 39.2
23040	200 7.874	310 12.2047	82 3.2283	1230 276000	1760 395000	EJ/EM	2 0.08	225 8.9	289 11.4	0.23	2.95	4.4	2.89	0.095	1800	1500	22.6 49.7
23044	220 8.6614	340 13.3858	90 3.5433	1340 300000	1970 443000	EJ/EM	2.5 0.1	247 9.7	313 12.3	0.24	2.77	4.13	2.71	0.105	1700	1400	29.8 65.6
23048	240 9.4488	360 14.1732	92 3.622	1400 315000	2140 480000	EJ/EM	2.5 0.1	267 10.5	334 13.1	0.23	2.91	4.34	2.85	0.111	1500	1300	31.9 70.2
23052	260 10.2362	400 15.748	104 4.0945	1820 409000	2740 617000	EJ/EMB	3 0.12	291 11.5	369 14.5	0.24	2.85	4.24	2.78	0.078	1300	1100	47.6 104.7
23056	280 11.024	420 16.535	106 4.173	1660 373000	2790 627000	EMB	3 0.12	312 12.3	389 15.3	0.23	2.92	4.35	2.86	0.088	1100	930	51.0 112.2
23060	300 11.811	460 18.11	118 4.646	2120 477000	3540 796000	EMB	3 0.12	336 13.2	425 16.8	0.24	2.87	4.27	2.8	0.093	980	830	71.0 156.2
23064	320 12.598	480 18.898	121 4.764	2200 494000	3850 867000	EMB	3 0.12	357 14.1	444 17.5	0.23	2.93	4.36	2.86	0.096	910	780	77.4 170.3
23068	340 13.386	520 20.472	133 5.236	2640 593000	4620 1040000	EMB	4 0.16	384 15.1	481 18.9	0.23	2.96	4.4	2.89	0.101	830	710	102.7 225.9
23072	360 14.173	540 21.26	134 5.276	2590 583000	4600 1030000	EMB	4 0.16	403 15.9	499 19.7	0.23	2.94	4.38	2.88	0.102	800	680	108.3 238.3
23076	380 14.961	560 22.047	135 5.315	2800 630000	5090 1140000	EMB	4 0.16	422 16.6	520 20.5	0.22	3.08	4.58	3.01	0.105	740	630	114.2 251.2
23080	400 15.748	600 23.622	148 5.827	3310 744000	5950 1340000	EMB	4 0.16	447 17.6	555 21.9	0.23	2.98	4.44	2.92	0.111	690	590	148.7 327.1
23084	420 16.535	620 24.409	150 5.906	3450 774000	6360 1430000	YMB	4 0.16	467 18.4	576 22.7	0.22	3.05	4.54	2.98	0.114	650	560	156.0 343.2

⁽¹⁾Maximum shaft or housing fillet radius that bearing corners will clear.

⁽²⁾These factors apply for both inch and metric calculations. See engineering section for instructions on use.

⁽³⁾Geometry constant for Lubrication Life Factor a_{31} is found in the Bearing Ratings section of the Engineering Manual (order no. 10424).

⁽⁴⁾See thermal speed ratings in the Engineering Manual (order no. 10424).

NOTE: Where EJ and EM/EMB have different load ratings, the more conservative one was taken to use for both assemblies.

NOTE: Tolerance and shaft diameters are shown in tables 2 and 3 on pages 19 and 20 as variances from nominal bearing bore.

231 SERIES (300, 3100 SERIES SNT, FSNT)

- Bearings are available with a tapered bore for adapter-type mounting. To order, add the suffix K to bearing number (e.g., 23120K).
- Consult your Timken engineer and www.timken.com for up-to-date information about the availability of the bearings you have selected.
- This section lists spherical roller bearings pertinent to Timken SNT plummer blocks. For a wider selection, consult www.timken.com or the Timken® Spherical Roller Bearing catalog (order no. 10446).

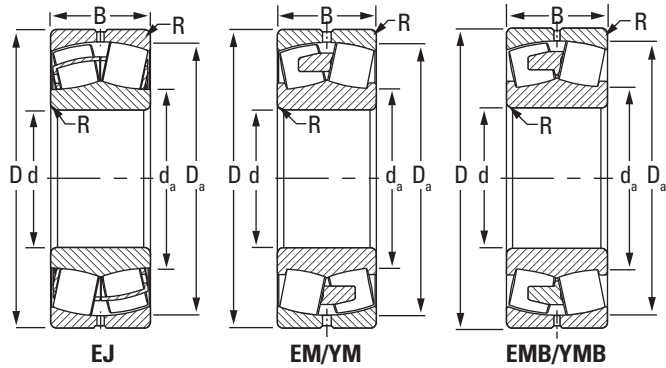

Bearing Part No.	Bearing Dimensions			Load Ratings		Cage Type	Mounting Data			Equivalent Radial Load Factors ⁽²⁾				Geometry Factor ⁽³⁾	Thermal Speed Ratings ⁽⁴⁾		Wt.
							Fillet ⁽¹⁾ (Max.)	Backing Dia.		Dynamic		Static	Oil		Grease		
	R	Shaft d _a	Housing D _a	F _a ≤ e F _r	F _a > e F _r			In All Cases	RPM	RPM	kg lbs.						
23134	170 6.6929	280 11.0236	88 3.4646	1220 274000	1710 384000	EJ/EM	2 0.08	195 7.7	258 10.1	0.28	2.39	3.55	2.33	0.091	1600	1400	21.7 47.7
23136	180 7.0866	300 11.811	96 3.7795	1410 317000	2000 449000	EJ/EM	2.5 0.1	208 8.2	275 10.8	0.29	2.32	3.45	2.27	0.095	1500	1300	27.6 60.7
23138	190 7.4803	320 12.5984	104 4.0945	1630 365000	2340 525000	EJ/EM	2.5 0.1	221 8.7	293 11.5	0.3	2.26	3.36	2.21	0.099	1400	1200	34.7 76.3
23140	200 7.874	340 13.3858	112 4.4094	1720 386000	2400 540000	EM/EMB	2.5 0.1	230 9	308 12.1	0.31	2.15	3.2	2.1	0.101	1300	1200	41.1 90.4
23144	220 8.6614	370 14.5669	120 4.7244	1940 436000	2740 616000	EJ/EMB	3 0.12	252 9.9	336 13.2	0.31	2.17	3.24	2.12	0.107	1200	1000	52.8 116.2
23148	240 9.4488	400 15.748	128 5.0394	2280 512000	3330 748000	EM/EMB	3 0.12	276 10.9	364 14.3	0.3	2.28	3.4	2.23	0.073	1100	930	64.9 142.8
23152	260 10.236	440 17.323	144 5.669	2440 549000	3910 879000	EMB	3 0.12	302 11.9	400 15.7	0.30	2.23	3.31	2.18	0.086	870	760	90.0 198.0
23156	280 11.024	460 18.11	146 5.748	2530 570000	4140 930000	EMB	4 0.16	320 12.6	419 16.5	0.30	2.26	3.36	2.21	0.09	800	710	94.5 207.9
23160	300 11.811	500 19.685	160 6.299	3070 691000	5110 1150000	EMB	4 0.16	345 13.6	453 17.8	0.30	2.25	3.35	2.20	0.093	710	630	128.7 283.1
23164	320 12.598	540 21.26	176 6.929	3650 819000	5930 1330000	EMB	4 0.16	367 14.4	490 19.3	0.31	2.14	3.19	2.10	0.099	650	580	167.2 367.8
23168	340 13.386	580 22.835	190 7.48	4110 924000	6830 1540000	EMB	4 0.16	397 15.6	526 20.7	0.30	2.22	3.30	2.17	0.103	590	530	210.3 462.7
23172	360 14.173	600 23.622	192 7.559	4250 956000	7280 1640000	EMB	4 0.16	419 16.5	546 21.5	0.29	2.29	3.42	2.24	0.106	560	500	222.1 488.6
23176	380 14.961	620 24.409	194 7.638	4490 1010000	7580 1700000	EMB	4 0.16	431 17	566 22.3	0.30	2.28	3.39	2.23	0.109	530	470	232.6 511.7
23180	400 15.748	650 25.591	200 7.874	4770 1070000	8110 1820000	EMB	5 0.2	454 17.9	594 23.4	0.29	2.32	3.46	2.27	0.11	500	450	261.6 575.5

⁽¹⁾Maximum shaft or housing fillet radius that bearing corners will clear.

⁽²⁾These factors apply for both inch and metric calculations. See engineering section for instructions on use.

⁽³⁾Geometry constant for Lubrication Life Factor a31 is found in the Bearing Ratings section of the Engineering Manual (order no. 10424).

⁽⁴⁾See thermal speed ratings in the Engineering Manual (order no. 10424).

NOTE: Where EJ and EM/EMB have different load ratings, the more conservative one was taken to use for both assemblies.

NOTE: Tolerance and shaft diameters are shown in tables 2 and 3 on pages 19 and 20 as variances from nominal bearing bore.

232 SERIES
(500, 600 SERIES SNT, FSNT)

- Bearings are available with a tapered bore for adapter-type mounting. To order, add the suffix K to bearing number (e.g., 23120K).
- Consult your Timken engineer and www.timken.com for up-to-date information about the availability of the bearings you have selected.
- This section lists spherical roller bearings pertinent to Timken SNT plummer blocks. For a wider selection, consult www.timken.com or the Timken® Spherical Roller Bearing catalog (order no. 10446).

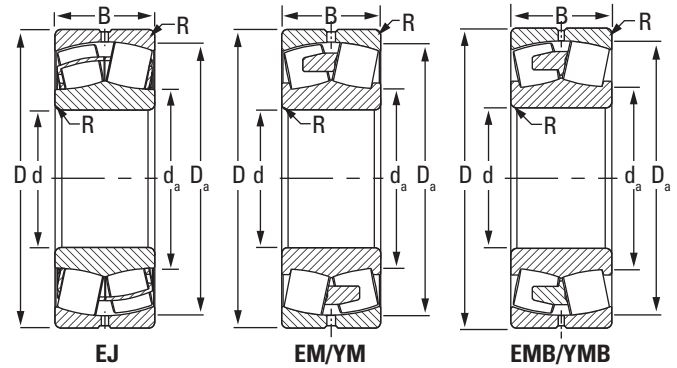

Bearing Part No.	Bearing Dimensions			Load Ratings		Cage Type	Mounting Data			Equivalent Radial Load Factors ⁽²⁾				Geometry Factor ⁽³⁾	Thermal Speed Ratings ⁽⁴⁾		Wt.
							Fillet ⁽¹⁾ (Max.)	Backing Dia.		e	Dynamic		Static		Oil	Grease	
	R	Shaft d _a	Housing D _a	F _a /F _r ≤ e	F _a /F _r > e			In All Cases									
	mm	mm	mm	kN	kN		mm	mm	mm		Y	Y	Y ₀		RPM	RPM	
23218	90 3.5433	160 6.2992	52.4 2.063	436 98000	521 117000	EJ/EM	2 0.08	107 4.2	147 5.8	0.3	2.28	3.4	2.23	0.074	3000	2600	4.5 9.9
23220	100 3.937	180 7.0866	60.3 2.374	554 124000	678 152000	EJ/EM	2 0.08	119 4.7	164 6.5	0.3	2.22	3.3	2.17	0.079	2700	2300	6.6 14.5
23222	110 4.3307	200 7.874	69.8 2.748	710 160000	887 199000	EJ/EM	2 0.08	131 5.2	182 7.2	0.32	2.11	3.14	2.06	0.085	2300	2000	9.6 21.1
23224	120 4.7244	215 8.4646	76 2.9921	824 185000	1040 234000	EJ/EM	2 0.08	142 5.6	197 7.7	0.32	2.1	3.13	2.05	0.075	2100	1800	11.8 26.0
23226	130 5.1181	230 9.0551	80 3.1496	915 206000	1170 262000	EJ/EM	2.5 0.1	153 6	211 8.3	0.32	2.14	3.19	2.09	0.079	1900	1700	14.0 30.8
23228	140 5.5118	250 9.8425	88 3.4646	1090 246000	1410 317000	EJ/EM	2.5 0.1	165 6.5	229 9	0.32	2.11	3.13	2.06	0.083	1700	1500	18.5 40.7
23230	150 5.9055	270 10.6299	96 3.7795	1270 286000	1660 372000	EJ/EM	2.5 0.1	178 7	247 9.7	0.32	2.08	3.1	2.04	0.087	1500	1400	23.8 52.4
23232	160 6.2992	290 11.4173	104 4.0945	1470 330000	1940 435000	EJ/EM	2.5 0.1	190 7.5	264 10.4	0.33	2.06	3.06	2.01	0.091	1400	1200	30.0 66.0
23234	170 6.6929	310 12.2047	110 4.3307	1660 373000	2200 494000	EM	3 0.12	202 8	281 11.1	0.33	2.08	3.09	2.03	0.094	1200	1100	36.6 80.5

⁽¹⁾Maximum shaft or housing fillet radius that bearing corners will clear.

⁽²⁾These factors apply for both inch and metric calculations. See engineering section for instructions on use.

⁽³⁾Geometry constant for Lubrication Life Factor a₃ is found in the Bearing Ratings section of the Engineering Manual (order no. 10424).

⁽⁴⁾See thermal speed ratings in the Engineering Manual (order no. 10424).

NOTE: Where EJ and EM/EMB have different load ratings, the more conservative one was taken to use for both assemblies.

NOTE: Tolerance and shaft diameters are shown in tables 2 and 3 on pages 19 and 20 as variances from nominal bearing bore.

SNT SPHERICAL ROLLER BEARING METRIC ACCESSORIES

Spherical roller bearing accessories are manufactured to the same quality standards as our bearings, ensuring a secure fit to both straight and stepped shafts.

- **Sizes:** Accessories are available for metric and inch shaft sizes from 20 mm to 400 mm.
- **Features:** Extensive product range, including hydraulic assist, for integration into a full range of industrial applications.
- **Benefits:** Supports full range of installation and removal needs, minimizing the chance for damage to the bearing.

Nomenclature	94
Accessories Prefixes and Suffixes	95
Metric Accessories Index	96
Metric H Adapter Sleeves	100
Metric OH Hydraulic Adapter Sleeves	104
Metric Locknuts	108
Metric Lockwashers	113
Metric Lockplates	115



NOMENCLATURE

Timken provides accessories for your every need. To complement our line of Timken® spherical roller bearings, we offer bearing sleeves and locking devices in a wide range of sizes. These accessories are manufactured to the same quality standards as our bearings, ensuring a secure fit to straight and stepped shafts. Available in sizes up to 1000 mm, bearing sleeves are available in two distinct designs: assembled adapter sleeves and withdrawal sleeves. Reference the Timken Spherical Roller Bearing Catalog (order no. 10446) for the full listing of accessories.

ADAPTER SLEEVES

Timken adapter sleeves are used in conjunction with a nut and locking device to mount a tapered bore bearing onto a straight shaft using a pull-type fit. Smaller size assemblies (20 mm–200 mm shaft) commonly use simple nuts, whereas larger assemblies (sizes >200 mm) may use HMV hydraulic nuts to assist in mounting. Tables 21 and 22 outline our part number nomenclature, which is consistent with world standards for adapter sleeves.

TABLE 21. METRIC ADAPTER SLEEVES (H, OH) FOR METRIC SHAFT SIZES ARE SUPPLIED WITH CORRESPONDING LOCKNUT AND LOCKING DEVICE

Sleeve	Locknut	Locking Device
H standard metric/OH hydraulic assist	KM, KML, HM	MB, MBL, MS

TABLE 22. METRIC ADAPTER SLEEVES (HA, HE) FOR INCH SHAFT SIZES ARE SUPPLIED WITH CORRESPONDING LOCKNUT AND LOCKING DEVICE

Sleeve	Locknut	Locking Device
HE standard inch (English Standard) HA standard inch (American Standard)	KM, KML	MB, MBL

WITHDRAWAL SLEEVES

Withdrawal sleeves feature a push-type mounting arrangement and a locking device (i.e., locknut or lockplate) to secure a bearing to a shaft. This design is not as widely used as the adapter sleeve assembly, and it does require the use of a specially designed dismantling nut. The Timken part number nomenclature for withdrawal sleeves also conforms to industry-accepted standards. Nuts are not supplied with the withdrawal sleeve and must be ordered separately. The dismantling of large assemblies can be eased by using a hydraulic nut (HMV).

TABLE 23. METRIC WITHDRAWAL SLEEVE FOR METRIC SHAFT SIZES

Sleeve	Dismounting Nut	Hydraulic Nut
AH standard metric/AOH hydraulic assist	KM, HM	HMV

LOCKING DEVICE

Timken offers a wide range of locknuts to locate bearing assemblies on application shafts. Sometimes referred to as shaft or withdrawal nuts, they are used to secure the assembly onto, and sometimes aid with the removal from the shaft.

LOCKWASHERS (MB, MBL AND W)

Locking washers are designed to secure the relative movement of a properly positioned locknut, so that a bearing and adapter sleeve remain tightly fitted to a shaft or a bearing remains secure against a shaft shoulder. The tab in the bore of the washer engages a keyway in the shaft or slot in the adapter sleeve. There are tabs on the O.D. of the washer that can be bent over into slots on the circumference of the locknut. Locking washers are used with locknuts in the KM and KML series.

LOCKPLATES (MS)

Lockplates are bolted onto the outboard face of the locknut and fit into a keyway machined in the shaft or a slot in the adapter sleeve.

- MS series are mounted on metric shafts sizes with HM locknuts.

To learn more about our spherical roller bearing accessories, contact your Timken engineer. Standard suffixes and prefixes are found on page 95.

ACCESSORIES PREFIXES AND SUFFIXES

Prefix	Suffix	Part Description	Full Description
AH		Withdrawal sleeve	Withdrawal sleeve
AHX		Withdrawal sleeve	Withdrawal sleeve – modified
AOH		Withdrawal sleeve – hydraulic	Withdrawal sleeve with oil hole on nut end
AOHX		Withdrawal sleeve – hydraulic	Withdrawal sleeve – modified with oil hole on nut end
H		Adapter sleeve – metric	Adapter sleeve
HA		Adapter sleeve metric – inch shaft	Metric adapter sleeves for shafts with inch dimensions (American Standards)
HE		Adapter sleeve metric – inch shaft	Metric adapter sleeves for shafts with inch dimensions (English Standards)
KM		Locknut	Locknut
KML		Locknut	Locknut – light; smaller outside diameter
HM		Locknut	Locknut/removal nut
HML		Locknut	Locknut/removal nut – light
HME		Locknut	Locknut/removal nut – with locking screw
HM...T		Locknut	Locknut/removal nut
HML...T		Locknut	Locknut/removal nut – light
HMLL...T		Locknut	Locknut/removal nut – super light
MB		Lockwasher	Lockwasher
MBL		Lockwasher	Lockwasher – light
MS		Lock clip	Locking clip
	G	Sleeve	Thread pitch diameter changed to ISO standard
	H	Locknut	Additional threaded holes on locknut for locking screws (no screws)
	HS	Locknut	Additional threaded holes on locknut for locking screws and screws
OH		Adapter sleeve – hydraulic	Adapter sleeve with oil hole on large end (opposite to the threaded end)
OH..	H	Adapter sleeve – hydraulic	Adapter sleeve with oil hole on nut end – standard design
OH..	HB	Adapter sleeve – hydraulic	Adapter sleeve with grooves and oil hole or two holes for bigger sizes on nut end
OH..	B	Adapter sleeve – hydraulic	Adapter sleeve with grooves and oil hole or two holes for bigger sizes on large end (opposite to the threaded end)
OH..	S	Adapter sleeve – hydraulic	Adapter sleeve with oil hole on large end (opposite to the threaded end) plus nut with eight threaded holes
OH..	BS	Adapter sleeve – hydraulic	Adapter sleeve with grooves and oil hole or two holes for bigger sizes on large end (opposite to the threaded end) plus nut with eight threaded holes

METRIC ACCESSORIES INDEX

Bearing Bore mm	Bearing Part No.	Adapter Sleeve		Withdrawal Sleeve	
		Metric Shaft	Hydraulic Metric Shaft	Metric Shaft	Hydraulic Metric Shaft
25	22205K	H305			
30	22206K	H306			
35	22207K	H307			
40	21308K	H308		AH308	
40	22208K	H308		AH308	
40	22308K	H2308		AH2308	
45	21309K	H309		AH309	
45	22209K	H309		AH309	
45	22309K	H2309		AH2309	
50	21310K	H310		AHX310	
50	22210K	H310		AHX310	
50	22310K	H2310		AHX2310	
55	21311K	H311		AHX311	
55	22211K	H311		AHX311	
55	22311K	H2311		AHX2311	
60	21312K	H312		AHX312	
60	22212K	H312		AHX312	
60	22312K	H2312		AHX2312	
65	21313K	H313		AH313G	
65	22213K	H313		AH313G	
65	22313K	H2313		AH2313G	
70	21314K	H314		AH314G	
70	22214K	H314		AH314G	
70	22314K	H2314		AHX2314G	
75	21315K	H315		AH315G	
75	22215K	H315		AH315G	
75	22315K	H2315		AHX2315G	
80	21316K	H316		AH316	
80	22216K	H316		AH316	
80	22316K	H2316		AHX2316	
85	21317K	H317		AHX317	
85	22217K	H317		AHX317	
85	22317K	H2317		AHX2317	
90	21318K	H318		AHX318	
90	22218K	H318		AHX318	
90	22318K	H2318		AHX2318	
90	23218K	H2318		AHX3218	
95	22219K	H319		AHX319	
95	22319K	H2319		AHX2319	
100	22220K	H320		AHX320	
100	22320K	H2320		AHX2320	
100	23120K	H3120		AHX3120	
100	23220K	H2320		AHX3220	
105	23221K	H2321			
110	22222K	H322		AHX3122	
110	22322K	H2322		AHX2322G	
110	23022K	H322		AHX322	
110	23122K	H3122		AHX3122	

Continued on next page.

Continued from previous page.

Bearing Bore mm	Bearing Part No.	Adapter Sleeve		Withdrawal Sleeve	
		Metric Shaft	Hydraulic Metric Shaft	Metric Shaft	Hydraulic Metric Shaft
110	23222K	H2322		AHX3222G	
110	24122K			AH24122	
120	22224K	H3124		AHX3124	
120	22324K	H2324		AHX2324G	
120	23024K	H3024		AHX3024	
120	23124K	H3124		AHX3124	
120	23224K	H2324		AHX3224G	
120	24024K			AH24024	
120	24124K			AH24124	
130	22226K	H3126		AHX3126	
130	22326K	H2326		AHX2326G	
130	23026K	H3026		AHX3026	
130	23126K	H3126		AHX3126	
130	23226K	H2326		AHX3226G	
130	23926K	H3926			
130	24026K			AH24026	
130	24126K			AH24126	
140	22228K	H3128		AHX3128	
140	22328K	H2328		AHX2328G	
140	23028K	H3028		AHX3028	
140	23128K	H3128		AHX3128	
140	23228K	H2328		AHX3228G	
140	23928K	H3928			
140	24028K			AH24028	
140	24128K			AH24128	
150	22230K	H3130		AHX3130G	
150	22330K	H2330		AHX2330G	
150	23030K	H3030		AHX3030	
150	23130K	H3130		AHX3130G	
150	23230K	H2330		AHX3230G	
150	23930K	H3930			
150	24030K			AH24030	
150	24130K			AH24130	
160	22232K	H3132	OH3132H	AH3132G	AOH3132G
160	22332K	H2332	OH2332H	AH2332G	AOH2332G
160	23032K	H3032	OH3032H	AH3032	
160	23132K	H3132	OH3132H	AH3132G	AOH3132G
160	23232K	H2332	OH2332H	AH3232G	AOH3232G
160	23932K	H3932	OH3932H		
160	24032K			AH24032	
160	24132K			AH24132	
170	22234K	H3134	OH3134H	AH3134G	AOH3134G
170	22334K	H2334	OH2334H	AH2334G	AOH2334G
170	23034K	H3034	OH3034H	AH3034	
170	23134K	H3134	OH3134H	AH3134G	AOH3134G
170	23234K	H2334	OH2334H	AH3234G	AOH3234G
170	23934K	H3934	OH3934H	AH3934	AOH3934
170	24034K			AH24034	

Continued on next page.

METRIC ACCESSORIES INDEX – *continued*

Bearing Bore mm	Bearing Part No.	Adapter Sleeve		Withdrawal Sleeve	
		Metric Shaft	Hydraulic Metric Shaft	Metric Shaft	Hydraulic Metric Shaft
170	24134K			AH24134	
180	22236K	H3136	OH3136H	AH2236G	AOH2236G
180	22336K	H2336	OH2336H	AH2336G	AOH2336G
180	23036K	H3036	OH3036H	AH3036	AOH3036
180	23136K	H3136	OH3136H	AH3136G	AOH3136G
180	23236K	H2336	OH2336H	AH3236G	AOH3236G
180	23936K	H3936	OH3936H	AH3936	AOH3936
180	24036K			AH24036	
180	24136K			AH24136	
190	22238K	H3138	OH3138H	AH2238G	AOH2238G
190	22338K	H2338	OH2338H	AH2338G	AOH2338G
190	23038K	H3038	OH3038H	AH3038G	AOH3038G
190	23138K	H3138	OH3138H	AH3138G	AOH3138G
190	23238K	H2338	OH2338H	AH3238G	AOH3238G
190	23938K	H3938	OH3938H	AH3938	AOH3938
190	24038K			AH24038	
190	24138K			AH24138	
200	22240K	H3140	OH3140H	AH2240	AOH2240
200	22340K	H2340	OH2340H	AH2340	AOH2340
200	23040K	H3040	OH3040H	AH3040G	AOH3040G
200	23140K	H3140	OH3140H	AH3140	AOH3140
200	23240K	H2340	OH2340H	AH3240	AOH3240
200	23940K	H3940	OH3940H	AH3940	AOH3940
200	24040K			AH24040	
200	24140K			AH24140	
220	22244K	H3144	OH3144H	AH2244	AOH2244
220	22344K	H2344	OH2344H	AH2344	AOH2344
220	23044K	H3044	OH3044H	AH3044G	AOH3044G
220	23144K	H3144	OH3144H	AH3144	AOH3144
220	23244K	H2344	OH2344H	AH2344	AOH2344
220	23944K	H3944	OH3944H	AH3944	AOH3944
220	24044K			AH24044	AOH24044
220	24144K			AH24144	AOH24144
240	22248K	H3148	OH3148H	AH2248	AOH2248
240	22348K	H2348	OH2348H	AH2348	AOH2348
240	23048K	H3048	OH3048H	AH3048	AOH3048
240	23148K	H3148	OH3148H	AH3148	AOH3148
240	23248K	H2348	OH2348H	AH2348	AOH2348
240	23948K	H3948	OH3948H	AH3948	AOH3948
240	24048K			AH24048	AOH24048
240	24148K			AH24148	AOH24148
260	22252K	H3152	OH3152H	AH2252G	AOH2252G
260	22352K	H2352	OH2352H	AH2352G	AOH2352G
260	23052K	H3052	OH3052H	AH3052	AOH3052
260	23152K	H3152	OH3152H	AH3152G	AOH3152G
260	23252K	H2352	OH2352H	AH2352G	AOH2352G
260	23952K	H3952	OH3952H	AH3952	AOH3952
260	24052K				AOH24052G

Continued on next page.

Continued from previous page.

Bearing Bore mm	Bearing Part No.	Adapter Sleeve		Withdrawal Sleeve	
		Metric Shaft	Hydraulic Metric Shaft	Metric Shaft	Hydraulic Metric Shaft
260	24152K			AH24152	AOH24152
280	22256K	H3156	OH3156H	AH2256G	AOH2256G
280	22356K	H2356	OH2356H	AH2356G	AOH2356G
280	23056K	H3056	OH3056H	AH3056	AOH3056
280	23156K	H3156	OH3156H	AH3156G	AOH3156G
280	23256K	H2356	OH2356H	AH2356G	AOH2356G
280	23956K	H3956	OH3956H	AH3956	AOH3956
280	24056K				AOH24056G
280	24156K			AH24156	AOH24156
300	22260K	H3160	OH3160H	AH2260G	AOH2260G
300	23060K	H3060	OH3060H	AH3060	AOH3060
300	23160K	H3160	OH3160H	AH3160G	AOH3160G
300	23260K	H3260	OH3260H	AH3260G	AOH3260G
300	23960K	H3960	OH3960H	AH3960	AOH3960
300	24060K				AOH24060G
300	24160K			AH24160	AOH24160
320	22264K	H3164	OH3164H	AH2264G	AOH2264G
320	23064K	H3064	OH3064H	AH3064G	AOH3064G
320	23164K	H3164	OH3164H	AH3164G	AOH3164G
320	23264K	H3264	OH3264H	AH3264G	AOH3264G
320	23964K	H3964	OH3964H	AH3964	AOH3964
320	24064K				AOH24064G
320	24164K			AH24164	AOH24164
340	23068K	H3068	OH3068H	AH3068G	AOH3068G
340	23168K	H3168	OH3168H	AH3168G	AOH3168G
340	23268K	H3268	OH3268H	AH3268G	AOH3268G
340	23968K	H3968	OH3968H	AH3968	AOH3968
340	24068K			AH24068	AOH24068
340	24168K			AH24168	AOH24168
360	23072K	H3072	OH3072H	AH3072G	AOH3072G
360	23172K	H3172	OH3172H	AH3172G	AOH3172G
360	23272K	H3272	OH3272H	AH3272G	AOH3272G
360	23972K	H3972	OH3972H	AH3972	AOH3972
360	24072K			AH24072	AOH24072
360	24172K			AH24172	AOH24172
380	23076K	H3076	OH3076H	AH3076G	AOH3076G
380	23176K	H3176	OH3176H	AH3176G	AOH3176G
380	23276K	H3276	OH3276H	AH3276G	AOH3276G
380	23976K	H3976	OH3976H	AH3976	AOH3976
380	24076K			AH24076	AOH24076
380	24176K			AH24176	AOH24176
400	22380K	H3280	OH3280H	AH3280G	AOH3280G
400	23080K	H3080	OH3080H	AH3080G	AOH3080G
400	23180K	H3180	OH3180H	AH3180G	AOH3180G
400	23280K	H3280	OH3280H	AH3280G	AOH3280G
400	23980K	H3980	OH3980H	AH3980	AOH3980
400	24080K			AH24080	AOH24080
400	24180K			AH24180	AOH24180

METRIC H ADAPTER SLEEVES

- Effective tapered bore bearing assembly.
- Includes mounting sleeve, locknut and lockwasher or lockplate.
- Other dimensions may be available, consult your Timken engineer.

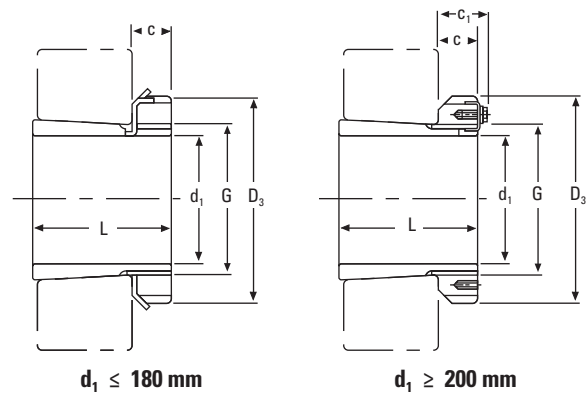

d_1	Sleeve Part No. ⁽¹⁾	L	C	Thread ⁽²⁾ G	D_3	C_1	Weight	Locknuts	Lockwasher and Lockplates	Appropriate Hydraulic Nut
mm		mm	mm	mm	mm	mm	kg			
20	H305	29	8	M 25x1.5	38	–	0.17	KM5	MB5	–
25	H306	31	8	M 30x1.5	45	–	0.24	KM6	MB6	–
30	H307	35	9	M 35x1.5	52	–	0.31	KM7	MB7	–
35	H308	36	10	M 40x1.5	58	–	0.42	KM8	MB8	–
35	H2308	46	10	M 40x1.5	58	–	0.22	KM8	MB8	–
40	H309	39	11	M 45x1.5	65	–	0.55	KM9	MB9	–
40	H2309	50	11	M 45x1.5	65	–	0.28	KM9	MB9	–
45	H310	42	12	M 50x1.5	70	–	0.67	KM10	MB10	HMV10
45	H2310	55	12	M 50x1.5	70	–	0.36	KM10	MB10	HMV10
50	H311	45	12	M 55x2	75	–	0.76	KM11	MB11	HMV11
50	H2311	59	12	M 55x2	75	–	0.42	KM11	MB11	HMV11
55	H312	47	13	M 60x2	80	–	0.87	KM12	MB12	HMV12
55	H2312	62	13	M 60x2	80	–	0.48	KM12	MB12	HMV12
60	H313	50	14	M 65x2	85	–	1.01	KM13	MB13	HMV13
60	H314	52	14	M 70x2	92	–	1.59	KM14	MB14	HMV14
60	H2313	65	14	M 65x2	85	–	0.56	KM13	MB13	HMV13
60	H2314	68	14	M 70x2	92	–	0.90	KM14	MB14	HMV14
65	H315	55	15	M 75x2	98	–	1.83	KM15	MB15	HMV15
65	H2315	73	15	M 75x2	98	–	1.05	KM15	MB15	HMV15
70	H316	59	17	M 80x2	105	–	2.27	KM16	MB16	HMV16
70	H2316	78	17	M 80x2	105	–	1.28	KM16	MB16	HMV16
75	H317	63	18	M 85x2	110	–	2.60	KM17	MB17	HMV17
75	H2317	82	18	M 85x2	110	–	1.45	KM17	MB17	HMV17
80	H318	65	18	M 90x2	120	–	3.02	KM18	MB18	HMV18
80	H2318	86	18	M 90x2	120	–	1.69	KM18	MB18	HMV18
85	H319	68	19	M 95x2	125	–	3.44	KM19	MB19	HMV19
85	H2319	90	19	M 95x2	125	–	1.92	KM19	MB19	HMV19
90	H320	71	20	M 100x2	130	–	3.73	KM20	MB20	HMV20
90	H3120	76	20	M 100x2	130	–	1.80	KM20	MB20	HMV20
90	H2320	97	20	M 100x2	130	–	2.15	KM20	MB20	HMV20

⁽¹⁾Adapter sleeves are supplied complete with locknuts and lockwasher or lockplates.

⁽²⁾M means metric thread and the digits are major diameter of thread and pitch.

NOTE: Sleeves are not sold separately.

Continued on next page.

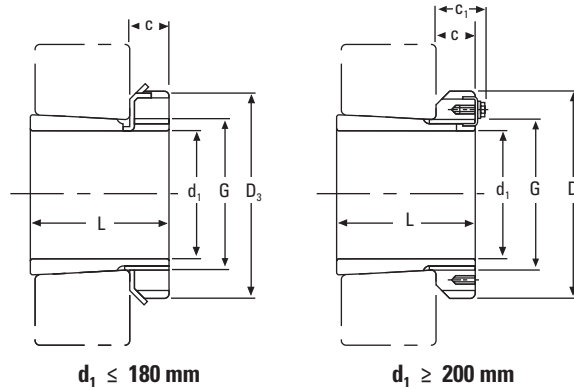

Continued from previous page.

d_1	Sleeve Part No. ⁽¹⁾	L	C	Thread ⁽²⁾ G	D_3	C_1	Weight	Locknuts	Lockwasher and Lockplates	Appropriate Hydraulic Nut
mm		mm	mm	mm	mm	mm	kg			
95	H321	74	20	M 105x2	140	–	4.30	KM 21	MB21	HMV21
95	H2321	101	20	M 105x2	140	–	2.46	KM21	MB21	HMV21
100	H322	77	21	M 110x2	145	–	4.81	KM22	MB22	HMV22
100	H3122	81	21	M 110x2	145	–	2.25	KM22	MB22	HMV22
100	H2322	105	21	M 110x2	145	–	2.74	KM22	MB22	HMV22
110	H3024	72	22	M 120x2	145	–	1.93	KML24	MBL24	HMV24
110	H3124	88	22	M 120x2	155	–	2.64	KM24	MB24	HMV24
110	H2324	112	22	M 120x2	155	–	3.19	KM24	MB24	HMV24
115	H3926	65	23	M 130x2	155	–	2.40	KML26	MBL26	HMV26
115	H3026	80	23	M 130x2	155	–	2.85	KML26	MBL26	HMV26
115	H3126	92	23	M 130x2	165	–	3.66	KM26	MB26	HMV26
115	H2326	121	23	M 130x2	165	–	4.60	KM26	MB26	HMV26
125	H3928	66	24	M 140x2	165	–	2.70	KML28	MBL28	HMV28
125	H3028	82	24	M 140x2	165	–	3.16	KML28	MBL28	HMV28
125	H3128	97	24	M 140x2	180	–	4.34	KM28	MB28	HMV28
125	H2328	131	24	M 140x2	180	–	5.55	KM28	MB28	HMV28
135	H3930	76	26	M 150x2	180	–	3.60	KML30	MBL30	HMV30
135	H3030	87	26	M 150x2	180	–	3.89	KML30	MBL30	HMV30
135	H3130	111	26	M 150x2	195	–	5.52	KM30	MB30	HMV30
135	H2330	139	26	M 150x2	195	–	6.63	KM30	MB30	HMV30
140	H3932	78	27.5	M 160x3	190	–	4.60	KML32	MBL32	HMV32
140	H3032	93	27.5	M 160x3	190	–	5.21	KML32	MBL32	HMV32
140	H3132	119	28	M 160x3	210	–	7.67	KM32	MB32	HMV32
140	H2332	147	28	M 160x3	210	–	9.14	KM32	MB32	HMV32
150	H3934	79	27.5	M 170x3	200	–	5.00	KML34	MBL34	HMV34
150	H3034	101	28.5	M 170x3	200	–	5.99	KML34	MBL34	HMV34
150	H3134	122	29	M 170x3	220	–	8.38	KM34	MB34	HMV34
150	H2334	154	29	M 170x3	220	–	10.20	KM34	MB34	HMV34

⁽¹⁾Adapter sleeves are supplied complete with locknuts and lockwasher or lockplates.

⁽²⁾M means metric thread and the digits are major diameter of thread and pitch.

NOTE: Sleeves are not sold separately.

Continued on next page.

METRIC H ADAPTER SLEEVES – continued

- Effective tapered bore bearing assembly.
- Includes mounting sleeve, locknut and lockwasher or lockplate.
- Other dimensions may be available, consult your Timken engineer.

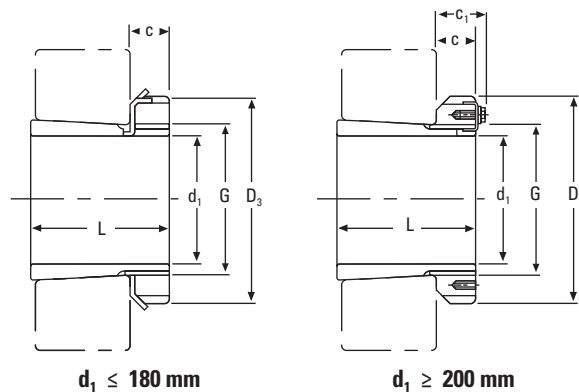

$d_1 \leq 180 \text{ mm}$

$d_1 \geq 200 \text{ mm}$

Continued from previous page.

d_1	Sleeve Part No. ⁽¹⁾	L	C	Thread ⁽²⁾⁽³⁾ G	D_3	C_1	Weight	Locknuts	Lockwasher and Lockplates	Appropriate Hydraulic Nut
mm		mm	mm	mm	mm	mm	kg			
160	H3936	87	29.5	M 180x3	210	–	5.70	KML36	MBL36	HMV36
160	H3036	109	29.5	M 180x3	210	–	6.83	KML36	MBL36	HMV36
160	H3136	131	30	M 180x3	230	–	9.50	KM36	MB36	HMV36
160	H2336	161	30	M 180x3	230	–	11.30	KM36	MB36	HMV36
170	H3938	89	30.5	M 190x3	220	–	6.19	KML38	MBL38	HMV38
170	H3038	112	30.5	M 190x3	220	–	7.45	KML38	MBL38	HMV38
170	H3138	141	31	M 190x3	240	–	10.80	KM38	MB38	HMV38
170	H2338	169	31	M 190x3	240	–	12.60	KM38	MB38	HMV38
180	H3940	98	31.5	M 200x3	240	–	7.89	KML40	MBL40	HMV40
180	H3040	120	31.5	M 200x3	240	–	9.19	KML40	MBL40	HMV40
180	H3140	150	32	M 200x3	250	–	12.10	KM40	MB40	HMV40
180	H2340	176	32	M 200x3	250	–	13.90	KM40	MB40	HMV40
200	H3944	96	30	Tr 220x4	260	41	8.16	HM3044	MS3044	HMV44
200	H3044	126	30	Tr 220x4	260	41	10.30	HM3044	MS3044	HMV44
200	H3144	161	35	Tr 220x4	280	–	15.10	HM44T	MB44	HMV44
200	H2344	186	35	Tr 220x4	280	–	17.00	HM44T	MB44	HMV44
220	H3948	101	34	Tr 240x4	290	46	11.00	HM3048	MS3048	HMV48
220	H3048	133	34	Tr 240x4	290	46	13.20	HM3048	MS3048	HMV48
220	H3148	172	37	Tr 240x4	300	–	17.60	HM48T	MS48	HMV48
220	H2348	199	37	Tr 240x4	300	–	20.00	HM48T	MS48	HMV48
240	H3952	116	34	Tr 260x4	310	46	12.80	HM3052	MS3052	HMV52
240	H3052	145	34	Tr 260x4	310	46	15.30	HM3052	MS3052	HMV52
240	H3152	190	39	Tr 260x4	330	–	22.30	HM52T	MB52	HMV52
240	H2352	211	39	Tr 260x4	330	–	24.50	HM52T	MB52	HMV52
260	H3956	121	38	Tr 280x4	330	50	15.30	HM3056	MS3056	HMV56
260	H3056	152	38	Tr 280x4	330	50	17.70	HM3056	MS3056	HMV56
260	H3156	195	41	Tr 280x4	350	–	25.10	HM56T	MB56	HMV56
260	H2356	224	41	Tr 280x4	350	–	28.40	HM56T	MB56	HMV56
280	H3960	140	42	Tr 300x4	360	54	20.00	HM3060	MS3060	HMV60
280	H3060	168	42	Tr 300x4	360	54	22.80	HM3060	MS3060	HMV60
280	H3160	208	40	Tr 300x4	380	53	30.20	HM3160	MS3160	HMV60
280	H3260	240	40	Tr 300x4	380	53	34.10	HM3160	MS3160	HMV60
300	H3964	140	42	Tr 320x5	380	55	21.50	HM3064	MS3064	HMV64
300	H3064	171	42	Tr 320x5	380	55	24.60	HM3064	MS3064	HMV64
300	H3164	226	42	Tr 320x5	400	56	34.90	HM3164	MS3164	HMV64
300	H3264	258	42	Tr 320x5	400	56	39.30	HM3164	MS3164	HMV64

⁽¹⁾Adapter sleeves are supplied complete with locknuts and lockwasher or lockplates.

⁽²⁾M means metric thread and the digits are major diameter of thread and pitch.

⁽³⁾Tr means 30°. Trapezoid thread and the digits are outside diameter of thread and pitch.

NOTE: Sleeves are not sold separately.

Continued on next page.

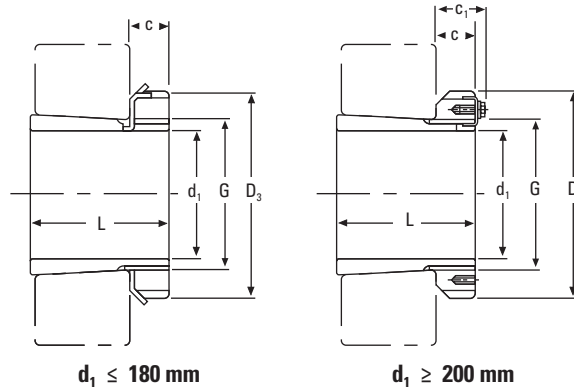

Continued from previous page.

d_1	Sleeve Part No. ⁽¹⁾	L	C	Thread ⁽²⁾ G	D_3	C_1	Weight	Locknuts	Lockwasher and Lockplates	Appropriate Hydraulic Nut
mm		mm	mm	mm	mm	mm	kg			
320	H3968	144	45	Tr 340x5	400	58	24.50	HM3068	MS3068	HMV68
320	H3068	187	45	Tr 340x5	400	58	28.70	HM3068	MS3068	HMV68
320	H3168	254	55	Tr 340x5	440	72	50.00	HM3168	MS3168	HMV68
320	H3268	288	55	Tr 340x5	440	72	54.60	HM3168	MS3168	HMV68
340	H3972	144	45	Tr 360x5	420	58	25.20	HM3072	MS3072	HMV72
340	H3072	188	45	Tr 360x5	420	58	30.50	HM3072	MS3072	HMV72
340	H3172	259	58	Tr 360x5	460	75	56.00	HM3172	MS3172	HMV72
340	H3272	299	58	Tr 360x5	460	75	60.60	HM3172	MS3172	HMV72
360	H3976	164	48	Tr 380x5	450	62	31.50	HM3076	MS3076	HMV76
360	H3076	193	48	Tr 380x5	450	62	35.80	HM3076	MS3076	HMV76
360	H3176	264	60	Tr 380x5	490	77	61.70	HM3176	MS3176	HMV76
360	H3276	310	60	Tr 380x5	490	77	69.60	HM3176	MS3176	HMV76
380	H3980	168	52	Tr 400x5	470	66	35.00	HM3080	MS3080	HMV80
380	H3080	210	52	Tr 400x5	470	66	41.30	HM3080	MS3080	HMV80
380	H3180	272	62	Tr 400x5	520	82	73.00	HM3180	MS3180	HMV80
380	H3280	328	62	Tr 400x5	520	82	81.00	HM3180	MS3180	HMV80
400	H3984	168	52	Tr 420x5	490	66	36.60	HM3084	MS3084	HMV84
400	H3084	212	52	Tr 420x5	490	66	43.70	HM3084	MS3084	HMV84
400	H3184	304	70	Tr 420x5	540	90	84.20	HM3184	MS3184	HMV84
400	H3284	352	70	Tr 420x5	540	90	96.00	HM3184	MS3184	HMV84
410	H3988	189	60	Tr 440x5	520	77	58.00	HM3088	MS3088	HMV88
410	H3088	228	60	Tr 440x5	520	77	65.20	HM3088	MS3088	HMV88
410	H3188	307	70	Tr 440x5	560	90	104.00	HM3188	MS3188	HMV88
410	H3288	361	70	Tr 440x5	560	90	118.00	HM3188	MS3188	HMV88
430	H3992	189	60	Tr 460x5	540	77	60.00	HM3092	MS3092	HMV92
430	H3192	326	75	Tr 460x5	580	95	116.00	HM3192	MS3192	HMV92
430	H3292	382	75	Tr 460x5	580	95	134.00	HM3192	MS3192	HMC92
450	H3996	200	60	Tr 480x5	560	77	66.00	HM3096	MS3096	HMV96
450	H3296	397	75	Tr 480x5	620	95	153.00	HM3196	MS3196	HMV96

⁽¹⁾Adapter sleeves are supplied complete with locknuts and lockwasher or lockplates.

⁽²⁾Tr means 30°. Trapezoid thread and the digits are outside diameter of thread and pitch.

NOTE: Sleeves are not sold separately.

METRIC OH HYDRAULIC ADAPTER SLEEVES

- Includes sleeve, nut and lockwasher or lockplate.
- Hydraulic assistance facilitates mounting of large bearing. Oil pump required to inject pressurized oil.
- Other dimensions may be available, consult your Timken engineer.

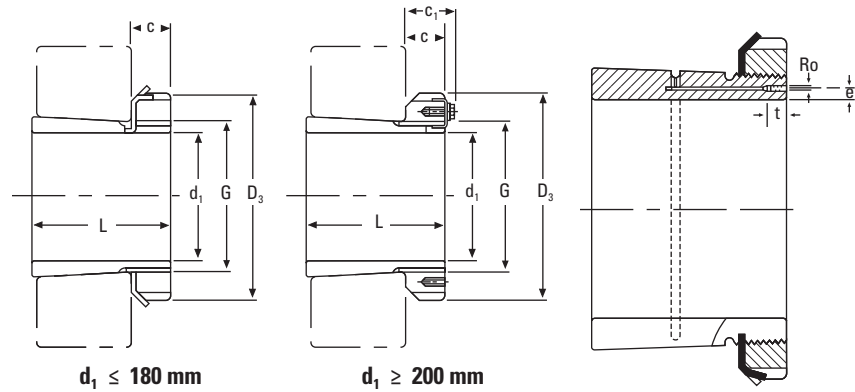

d_1	Sleeve Part No. ⁽¹⁾	L	C	Thread ⁽²⁾⁽³⁾ G	D_3	C_1 ⁽⁴⁾	R_o	e	t	Weight	Locknuts	Lockwasher and Lockplate	Appropriate Hydraulic Nut
mm		mm	mm	mm	mm	mm		mm	mm	kg			
140	OH3032H	93	27.5	M 160x3	190	–		4	7	5.21	KML32	MBL32	HMV32
140	OH3132H	119	28	M 160x3	210	–		4	7	7.67	KM32	MB32	HMV32
150	OH3034H	101	28.5	M 170x3	200	–		4	7	5.99	KML34	MBL34	HMV34
150	OH3134H	122	29	M 170x3	220	–		4	7	8.38	KM34	MB34	HMV34
160	OH3936H	87	29.5	M 180x3	210	–		4	7	5.70	KML36	MBL36	HMV36
160	OH3036H	109	29.5	M 180x3	210	–		4	7	6.83	KML36	MBL36	HMV36
160	OH3136H	131	30	M 180x3	230	–		4	7	9.50	KM36	MB36	HMV36
170	OH3938H	89	30.5	M 190x3	220	–		4	7	6.19	KML38	MBL38	HMV38
170	OH3038H	112	30.5	M 190x3	220	–		4	7	7.45	KML38	MBL38	HMV38
170	OH3138H	141	31	M 190x3	240	–		4	7	10.80	KM38	MB38	HMV38
170	OH2338H	169	31	M 190x3	240	–		4	7	12.60	KM38	MB38	HMV38
180	OH3940H	98	31.5	M 200x3	240	–		4	7	7.89	KML40	MBL40	HMV40
180	OH3040H	120	31.5	M 200x3	240	–		4	7	9.19	KML40	MBL40	HMV40
180	OH3140H	150	32	M 200x3	250	–		4	7	12.10	KM40	MB40	HMV40
180	OH2340H	176	32	M 200x3	250	–		4	7	13.90	KM40	MB40	HMV40
200	OH3944H	96	30	Tr 220x4	260	41	M6	4	7	8.16	HM3044	MS3044	HMV44
200	OH3044H	126	30	Tr 220x4	260	41	M6	4	7	10.30	HM3044	MS3044	HMV44
200	OH3144H	161	35	Tr 220x4	280	–	M6	4	7	15.10	HM44T	MB44	HMV44
200	OH2344H	186	35	Tr 220x4	280	–	M6	4	7	17.00	HM44T	MB44	HMV44
220	OH3948H	101	34	Tr 240x4	290	46	M6	4	7	11.00	HM3048	MS3048	HMV48
220	OH3048H	133	34	Tr 240x4	290	46	M6	4	7	13.20	HM3048	MS3048	HMV48
220	OH3148H	172	37	Tr 240x4	300	–	M6	4	7	17.60	HM48T	MB48	HMV48
220	OH2348H	199	37	Tr 240x4	300	–	M6	4	7	20.00	HM48T	MB48	HMV48
240	OH3952H	116	34	Tr 260x4	310	46	M6	4	7	12.80	HM3052	MS3052	HMV52
240	OH3052H	145	34	Tr 260x4	310	46	M6	4	7	15.30	HM3052	MS3052	HMV52
240	OH3152H	190	39	Tr 260x4	330	–	M6	4	7	22.30	HM52T	MB52	HMV52
240	OH2352H	211	39	Tr 260x4	330	–	M6	4	7	24.50	HM52T	MB52	HMV52

⁽¹⁾Hydraulic adapter sleeves are supplied complete with locknuts and lockwasher or lockplates.

⁽²⁾M means metric thread and the digits are major diameter of thread and pitch.

⁽³⁾Tr means 30°. Trapezoid thread and the digits are outside diameter of thread and pitch.

⁽⁴⁾Adapters with dimensions C_1 have a locking device as shown in the illustration.

Continued on next page.

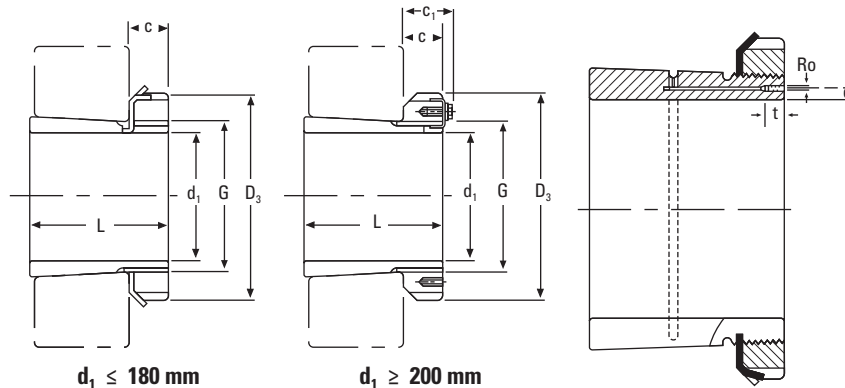

Continued from previous page.

$d_1 \leq 180 \text{ mm}$

$d_1 \geq 200 \text{ mm}$

d_1 mm	Sleeve Part No. ⁽¹⁾	L mm	C mm	Thread ⁽²⁾ G	D_3 mm	C_1 ⁽³⁾ mm	R_o	e mm	t mm	Weight kg	Locknuts	Lockwasher and Lockplate	Appropriate Hydraulic Nut
260	OH3956H	121	38	Tr 280x4	330	50	M6	4	7	15.30	HM3056	MS3056	HMV56
260	OH3056H	152	38	Tr 280x4	330	50	M6	4	7	17.70	HM3056	MS3056	HMV56
260	OH3156H	195	41	Tr 280x4	350	—	M6	4	7	25.10	HM56T	MB56	HMV56
260	OH2356H	224	41	Tr 280x4	350	—	M6	4	7	28.40	HM56T	MB56	HMV56
280	OH3960H	140	42	Tr 300x4	360	54	M6	4	7	20.00	HM3060	MS3060	HMV60
280	OH3060H	168	42	Tr 300x4	360	54	M6	4	7	22.80	HM3060	MS3060	HMV60
280	OH3160H	208	40	Tr 300x4	380	53	M6	4	7	30.20	HM3160	MS3160	HMV60
280	OH3260H	240	40	Tr 300x4	380	53	M6	4	7	34.10	HM3160	MS3160	HMV60
300	OH3964H	140	42	Tr 320x5	380	55	M6	3.5	7	21.50	HM3064	MS3064	HMV64
300	OH3064H	171	42	Tr 320x5	380	55	M6	3.5	7	24.60	HM3064	MS3064	HMV64
300	OH3164H	226	42	Tr 320x5	400	56	M6	3.5	7	34.90	HM3164	MS3164	HMV64
300	OH3264H	258	42	Tr 320x54	400	56	M6	3.5	7	39.30	HM3164	MS3164	HMV64
320	OH3968H	144	45	Tr 340x5	400	58	M6	3.5	7	24.50	HM3068	MS3068	HMV68
320	OH3068H	187	45	Tr 340x5	400	58	M6	3.5	7	28.70	HM3068	MS3068	HMV68
320	OH3168H	254	55	Tr 340x5	440	72	M6	3.5	7	50.00	HM3168	MS3168	HMV68
320	OH3268H	288	55	Tr 340x5	440	72	M6	3.5	7	54.60	HM3168	MS3168	HMV68
340	OH3972H	144	45	Tr 360x5	420	58	M6	3.5	7	25.20	HM3072	MS3072	HMV72
340	OH3072H	188	45	Tr 360x5	420	58	M6	3.5	7	30.50	HM3072	MS3072	HMV72
340	OH3172H	259	58	Tr 360x5	460	75	M6	3.5	7	56.00	HM3172	MS3172	HMV72
340	OH3272H	299	58	Tr 360x5	460	75	M6	3.5	7	60.60	HM3172	MS3172	HMV72
360	OH3976H	164	48	Tr 380x5	450	62	M6	3.5	7	31.50	HM3076	MS3076	HMV76
360	OH3076H	193	48	Tr 380x5	450	62	M6	3.5	7	35.80	HM3076	MS3076	HMV76
360	OH3176H	264	60	Tr 380x5	490	77	M6	3.5	7	61.70	HM3176	MS3176	HMV76
360	OH3276H	310	60	Tr 380x5	490	77	M6	3.5	7	69.60	HM3176	MS3176	HMV76
380	OH3980H	168	52	Tr 400x5	470	66	M6	3.5	7	35.00	HM3080	MS3080	HMV80
380	OH3080H	210	52	Tr 400x5	470	66	M6	3.5	7	41.30	HM3080	MS3080	HMV80
380	OH3180H	272	62	Tr 400x5	520	82	M6	3.5	7	73.00	HM3180	MS3180	HMV80
380	OH3280H	328	62	Tr 400x5	520	82	M6	3.5	7	81.00	HM3180	MS3180	HMV80

⁽¹⁾Hydraulic adapter sleeves are supplied complete with locknuts and lockwasher or lockplates.

⁽²⁾Tr means 30°. Trapezoid thread and the digits are outside diameter of thread and pitch.

⁽³⁾Adapters with dimensions C_1 have a locking device as shown in the illustration.

Continued on next page.

METRIC OH HYDRAULIC ADAPTER SLEEVES – continued

- Includes sleeve, nut and lockwasher or lockplate.
- Hydraulic assistance facilitates mounting of large bearing. Oil pump required to inject pressurized oil.
- Other dimensions may be available, consult your Timken engineer.

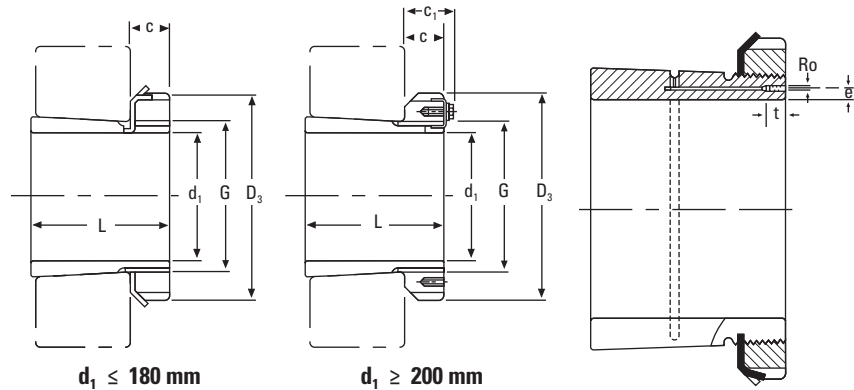

Continued from previous page.

d_1	Sleeve Part No. ⁽¹⁾	L	C	Thread ⁽²⁾ G	D_3	C_1 ⁽³⁾	R_o	e	t	Weight	Locknuts	Lockwasher and Lockplate	Appropriate Hydraulic Nut
mm		mm	mm	mm	mm	mm		mm	mm	kg			
400	OH3984H	168	52	Tr 420x5	490	66	M6	3.5	7	36.60	HM3084	MS3084	HMV84
400	OH3084H	212	52	Tr 420x5	490	66	M6	3.5	7	43.70	HM3084	MS3084	HMV84
400	OH3184H	304	70	Tr 420x5	540	90	M6	3.5	7	84.20	HM3184	MS3184	HMV84
400	OH3284H	352	70	Tr 420x5	540	90	M6	3.5	7	96.00	HM3184	MS3184	HMV84
410	OH3988H	189	60	Tr 440x5	520	77	M8	6.5	12	58.00	HM3088	MS3088	HMV88
410	OH3088H	228	60	Tr 440x5	520	77	M8	6.5	12	65.20	HM3088	MS3088	HMV88
410	OH3188H	307	70	Tr 440x5	560	90	M8	6.5	12	104.00	HM3188	MS3188	HMV88
410	OH3288H	361	70	Tr 440x5	560	90	M8	6.5	12	118.00	HM3188	MS3188	HMV88
430	OH3992H	189	60	Tr 460x5	540	77	M8	6.5	12	60.00	HM3092	MS3092	HMV92
430	OH3092H	234	60	Tr 460x5	540	77	M8	6.5	12	71.00	HM3092	MS3092	HMV92
430	OH3192H	326	75	Tr 460x5	580	95	M8	6.5	12	116.00	HM3192	MS3192	HMV92
430	OH3292H	382	75	Tr 460x5	580	95	M8	6.5	12	134.00	HM3192	MS3192	HMV92
450	OH3996H	200	60	Tr 480x5	560	77	M8	6.5	12	66.00	HM3096	MS30/96	HMV96
450	OH3096H	237	60	Tr 480x5	560	77	M8	6.5	12	75.00	HM3096	MS30/96	HMV96
450	OH3196H	335	75	Tr 480x5	620	95	M8	6.5	12	135.00	HM3196	MS3196	HMV96
450	OH3296H	397	75	Tr 480x5	620	95	M8	6.5	12	153.00	HM3196	MS3196	HMV96
470	OH39/500H	208	68	Tr 500x5	580	85	M8	6.5	12	74.30	HM30/500	MS30/500	HMV100
470	OH31/500H	356	80	Tr 500x5	630	100	M8	6.5	12	145.00	HM31/500	MS31/500	HMV100
470	OH32/500H	428	80	Tr 500x5	630	100	M8	6.5	12	166.00	HM31/500	MS31/500	HMV100
500	OH39/530H	216	68	Tr 530x6	630	90	M8	6	12	87.90	HM30/530	MS30/530	HMV106
500	OH31/530H	364	80	Tr 530x6	670	105	M8	6	12	161.00	HM31/530	MS31/530	HMV106
500	OH32/530H	447	80	Tr 530x6	670	105	M8	6	12	192.00	HM31/530	MS31/530	HMV106
530	OH39/560H	227	75	Tr 560x6	650	97	M8	6	12	95.00	HM30/560	MS30/560	HMV112
530	OH31/560H	377	85	Tr 560x6	710	110	M8	6	12	185.00	HM31/560	MS31/560	HMV112
530	OH32/560H	462	85	Tr 560x6	710	110	M8	6	12	219.00	HM31/560	MS31/560	HMV112
560	OH39/600H	239	75	Tr 600x6	700	97	G1/8	8	13	127.00	HM30/600	MS30/600	HMV120
560	OH30/600H	289	75	Tr 600x6	700	97	G1/8	8	13	147.00	HM30/600	MS30/600	HMV120
560	OH31/600H	399	85	Tr 600x6	750	110	G1/8	8	13	234.00	HM31/600	MS31/600	HMV120
560	OH32/600H	487	85	Tr 600x6	750	110	G1/8	8	13	278.00	HM31/600	MS31/600	HMV120
600	OH39/630H	254	75	Tr 630x6	730	97	M8	6	12	124.00	HM30/630	MS30/630	HMV126
600	OH30/630H	301	75	Tr 630x6	730	97	M8	6	12	138.00	HM30/630	MS30/630	HMV126
600	OH31/630H	424	95	Tr 630x6	800	120	M8	6	12	254.00	HM31/630	MS31/630	HMV126
600	OH32/630H	521	95	Tr 630x6	800	120	M8	6	12	300.00	HM 31/630	MS31/630	HMV126

⁽¹⁾Hydraulic adapter sleeves are supplied complete with locknuts and lockwasher or lockplates.

⁽²⁾Tr means 30°. Trapezoid thread and the digits are outside diameter of thread and pitch.

⁽³⁾Adapters with dimensions C_1 have a locking device as shown in the illustration.

Continued on next page.

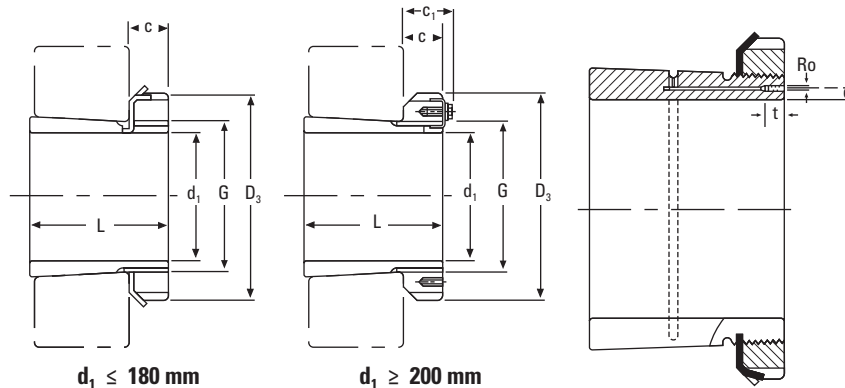

Continued from previous page.

d_1	Sleeve Part No. ⁽¹⁾	L	C	Thread ⁽²⁾ G	D_3	C_1 ⁽³⁾	R_o	e	t	Weight	Locknuts	Lockwasher and Lockplate	Appropriate Hydraulic Nut
mm		mm	mm	mm	mm	mm		mm	mm	kg			
630	OH39/670H	264	80	Tr 670x6	780	102	G1/8	8	13	162.00	HM30/670	MS30/670	HMV134
630	OH30/670H	324	80	Tr 670x6	780	102	G1/8	8	13	190.00	HM30/670	MS30/670	HMV134
630	OH31/670H	456	106	Tr 670x6	850	131	G1/8	8	13	340.00	HM31/670	MS31/670	HMV134
630	OH32/670H	558	106	Tr 670x6	850	131	G1/8	8	13	401.00	HM31/670	MS31/670	HMV134
670	OH39/710H	286	90	Tr 710x7	830	112	G1/8	8	13	183.00	HM30/710	MS30/710	HMV142
670	OH30/710H	342	90	Tr 710x7	830	112	G1/8	8	13	228.00	HM30/710	MS30/710	HMV142
670	OH31/710H	467	106	Tr 710x7	900	135	G1/8	8	13	392.00	HM31/710	MS31/710	HMV142
670	OH32/710H	572	106	Tr 710x7	900	135	G1/8	8	13	459.00	HM31/710	MS31/710	HMV142
710	OH39/750H	291	90	Tr 750x7	870	112	G1/8	8	13	211.00	HM30/750	MS30/750	HMV150
710	OH30/750H	356	90	Tr 750x7	870	112	G1/8	8	13	246.00	HM30/750	MS30/750	HMV150
710	OH31/750H	493	112	Tr 750x7	950	141	G1/8	8	13	451.00	HM31/750	MS31/750	HMV150
710	OH32/750H	603	112	Tr 750x7	950	141	G1/8	8	13	526.00	HM31/750	MS31/750	HMV150
750	OH39/800H	303	90	Tr 800x7	920	112	G1/8	10	13	259.00	HM30/800	MS30/800	HMV160
750	OH31/800H	505	112	Tr 800x7	1000	141	G1/8	10	13	535.00	HM31/800	MS31/800	HMV160
750	OH32/800H	618	112	Tr 800x7	1000	141	G1/8	10	13	629.00	HM31/800	MS31/800	HMV160
800	OH39/850H	308	90	Tr 850x7	980	115	G1/8	10	13	288.00	HM30/850	MS30/850	HMV170
800	OH31/850H	536	118	Tr 850x7	1060	147	G1/8	10	13	616.00	HM31/850	MS31/850	HMV170
800	OH32/850H	651	118	Tr 850x7	1060	147	G1/8	10	13	722.00	HM31/850	MS31/850	HMV170
850	OH39/900H	326	100	Tr 900x7	1030	125	G1/8	10	13	330.00	HM30/900	MS30/900	HMV180
850	OH31/900H	557	125	Tr 900x7	1120	154	G1/8	10	13	677.00	HM31/900	MS31/900	HMV180
850	OH32/900H	660	125	Tr 900x7	1120	154	G1/8	10	13	776.00	HM31/900	MS31/900	HMV180
900	OH39/950H	344	100	Tr 950x8	1080	125	G1/8	10	13	362.00	HM30/950	MS30/950	HMV190
900	OH31/950H	583	125	Tr 950x8	1170	154	G1/8	10	13	738.00	HM31/950	MS31/950	HMV190
900	OH32/950H	675	125	Tr 950x8	1170	154	G1/8	10	13	834.00	HM31/950	MS31/950	HMV190
950	OH39/1000H	358	100	Tr 1000x8	1140	125	G1/8	10	13	407.00	HM30/1000	MS30/1000	HMV200
950	OH31/1000H	609	125	Tr 1000x8	1240	154	G1/8	10	13	842.00	HM31/1000	MS31/1000	HMV200
950	OH32/1000H	707	125	Tr 1000x8	1240	154	G1/8	10	13	952.00	HM31/1000	MS31/1000	HMV200
1000	OH39/1060H	372	100	Tr 1060x8	1200	125	G1/8	12	15	490.00	HM30/1060	MS30/1060	HMV212
1000	OH30/1060H	447	100	Tr 1060x8	1200	125	G1/8	12	15	571.00	HM30/1060	MS30/1060	HMV212
1000	OH31/1060H	622	125	Tr 1060x8	1300	154	G1/8	12	15	984.00	HM31/1060	MS31/1060	HMV212

⁽¹⁾Hydraulic adapter sleeves are supplied complete with locknuts and lockwasher or lockplates.

⁽²⁾Tr means 30°. Trapezoid thread and the digits are outside diameter of thread and pitch.

⁽³⁾Adapters with dimensions C_1 have a locking device as shown in the illustration.

METRIC LOCKNUTS

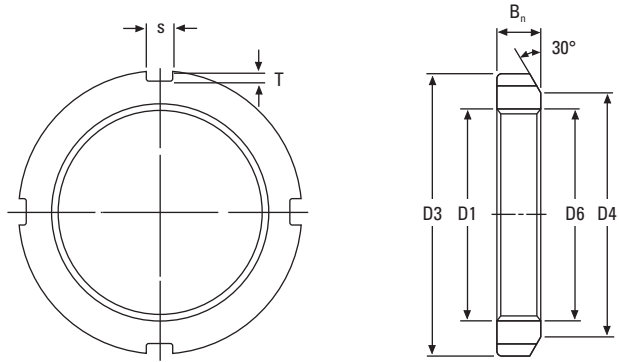

Locknut No. ⁽¹⁾	Thread ⁽²⁾ D ₁	D ₃	D ₄	B _n	s	T	D ₆	Weight	Lockwasher No.
	mm	mm	mm	mm	mm	mm	mm	kg	
KM0	M 10 X 0.75	18	13	4	3	2	10.5	0.01	MB00
KM1	M 12 X 1.0	22	17	4	3	2	12.5	0.01	MB01
KM2	M 15 X 1.0	25	21	5	4	2	15.5	0.01	MB02
KM3	M 17 X 1.0	28	24	5	4	2	17.5	0.01	MB03
KM4	M 20 X 1.0	32	26	6	4	2	20.5	0.02	MB04
KM5	M 25 X 1.5	38	32	7	5	2	25.8	0.03	MB05
KM6	M 30 X 1.5	45	38	7	5	2	30.8	0.04	MB06
KM7	M 35 X 1.5	52	44	8	5	2	35.8	0.05	MB07
KM8	M 40 X 1.5	58	50	9	6	2.5	40.8	0.09	MB08
KM9	M 45 X 1.5	65	56	10	6	2.5	45.8	0.12	MB09
KM10	M 50 X 1.5	70	61	11	6	2.5	50.8	0.15	MB10
KM11	M 55 X 2.0	75	67	11	7	3	56.0	0.16	MB11
KM12	M 60 X 2.0	80	73	11	7	3	61.0	0.17	MB12
KM13	M 65 X 2.0	85	79	12	7	3	66.0	0.20	MB13
KM14	M 70 X 2.0	92	85	12	8	3.5	71.0	0.24	MB14
KM15	M 75 X 2.0	98	90	13	8	3.5	76.0	0.29	MB15
KM16	M 80 X 2.0	105	95	15	8	3.5	81.0	0.40	MB16
KM17	M 85 X 2.0	110	102	16	8	3.5	86.0	0.45	MB17
KM18	M 90 X 2.0	120	108	16	10	4	91.0	0.56	MB18
KM19	M 95 X 2.0	125	113	17	10	4	96.0	0.66	MB19
KM20	M 100 X 2.0	130	120	18	10	4	101.0	0.70	MB20
KM21	M 105 X 2.0	140	126	18	12	5	106.0	0.85	MB21
KM22	M 110 X 2.0	145	133	19	12	5	111.0	0.97	MB22
KM23	M 115 X 2.0	150	137	19	12	5	116.0	1.01	MB23
KM24	M 120 X 2.0	160	148	21	12	5	126.0	1.80	MB24
KM25	M 125 X 2.0	160	148	21	12	5	126.0	1.19	MB25
KM26	M 130 X 2.0	165	149	21	12	5	131.0	1.25	MB26
KM27	M 135 X 2.0	175	160	22	14	6	136.0	1.55	MB27
KM28	M 140 X 2.0	180	160	22	14	6	141.0	1.56	MB28
KM29	M145 X 2.0	190	172	24	14	6	146.0	2.00	MB29

⁽¹⁾No. KM0-KM40 also available in 304 stainless steel.

⁽²⁾M means metric thread and the digits are major diameter of thread and pitch.

Continued on next page.

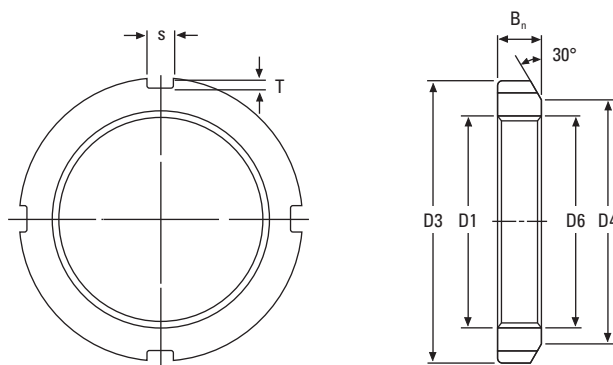

Continued from previous page.

Locknut No. ⁽¹⁾	Thread ⁽²⁾ D ₁	D ₃	D ₄	B _n	s	T	D ₆	Weight	Lockwasher No.
	mm	mm	mm	mm	mm	mm	mm	kg	
KM30	M150 X 2.0	195	171	24	14	6	151.0	2.03	MB30
KM31	M155 X 3.0	200	182	25	16	7	156.5	2.21	MB31
KM32	M160 X 3.0	210	182	25	16	7	161.5	2.59	MB32
KM33	M165 X 3.0	210	193	26	16	7	166.5	2.43	MB33
KM34	M170 X 3.0	220	193	26	16	7	171.5	2.80	MB34
KM36	M180 X 3.0	230	203	27	18	8	181.5	3.07	MB36
KM38	M190 X 3.0	240	214	28	18	8	191.5	3.39	MB38
KM40	M200 X 3.0	250	226	29	18	8	201.5	3.69	MB40

⁽¹⁾No. KM0 - KM40 also available in 304 stainless steel.

⁽²⁾M means metric thread and the digits are major diameter of thread and pitch.

METRIC LOCKNUTS – continued

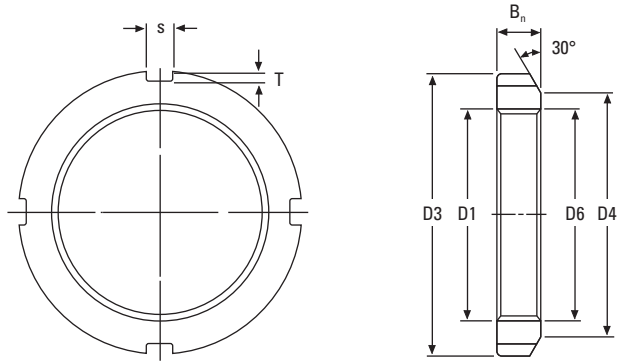

Locknut No.	Thread ⁽¹⁾ D ₁	D ₃	D ₄	B _n	s	T	D ₆	Weight
	mm	mm	mm	mm	mm	mm	mm	kg
HM42	Tr 210 x 4	270	238	30	20	10	212	4.75
HM44	Tr 220 x 4	280	250	32	20	10	222	5.35
HM46	Tr 230 x 4	290	260	34	20	10	232	5.80
HM48	Tr 240 x 4	300	270	34	20	10	242	6.20
HM50	Tr 250 x 4	320	290	36	20	10	252	7.00
HM52	Tr 260 x 4	330	300	36	24	12	262	8.55
HM54	Tr 270 x 4	340	310	38	24	12	272	9.20
HM56	Tr 280 x 4	350	320	38	24	12	282	10.00
HM58	Tr 290 x 4	370	330	40	24	12	292	11.80
HM60	Tr 300 x 4	380	340	40	24	12	302	12.00
HM62	Tr 310 x 5	390	350	42	24	12	312.5	13.40
HM64	Tr 320 x 5	400	360	42	24	12	322.5	13.50
HM66	Tr 330 x 5	420	380	52	28	15	332.5	20.40
HM68	Tr 340 x 5	440	400	55	28	15	342.5	24.50
HM70	Tr 350 x 5	450	410	55	28	15	352.5	25.20
HM72	Tr 360 x 5	460	420	58	28	15	362.5	27.50
HM74	Tr 370 x 5	470	430	58	28	15	372.5	28.20
HM76	Tr 380 x 5	490	450	60	32	18	382.5	33.50
HM80	Tr 400 x 5	520	470	62	32	18	402.5	40.00

⁽¹⁾Tr means 30°; trapezoid thread and the digits are major diameter of thread and pitch.

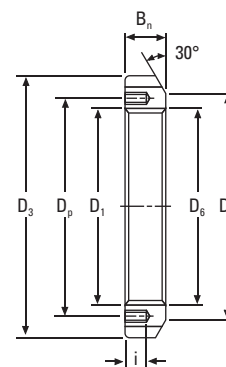
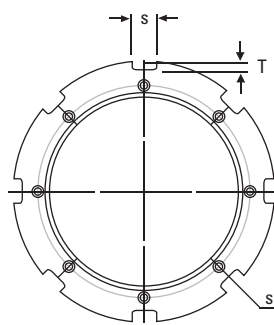

Locknut No.	Thread ⁽¹⁾ D ₁	D ₃	D ₄	s	T	D ₆	B _n	i	Tapped Hole Threads	D _p	Appropriate Lockplate No.	Weight
	mm	mm	mm	mm	mm	mm	mm	mm		mm		kg
HM3044	Tr 220 x 4	260	242	20	9	222	30	12	M 6 x 1	229	MS3044	3.09
HM3048	Tr 240 x 4	290	270	20	10	242	34	15	M 8 x 1.25	253	MS3048	5.16
HM3052	Tr 260 x 4	310	290	20	10	262	34	15	M 8 x 1.25	273	MS3052	5.67
HM3056	Tr 280 x 4	330	310	24	10	282	38	15	M 8 x 1.25	293	MS3056	6.78
HM3060	Tr 300 x 4	360	336	24	12	302	42	15	M 8 x 1.25	316	MS3060	9.62
HM3064	Tr 320 x 5	380	356	24	12	322.5	42	15	M 8 x 1.25	335	MS3064	9.94
HM3068	Tr 340 x 5	400	376	24	12	342.5	45	15	M 8 x 1.25	355	MS3068	11.70
HM3072	Tr 360 x 5	420	394	28	13	362.5	45	15	M 8 x 1.25	374	MS3072	12.00
HM3076	Tr 380 x 5	450	422	28	14	382.5	48	18	M 10 x 1.5	398	MS3076	14.90
HM3080	Tr 400 x 5	470	442	28	14	402.5	52	18	M 10 x 1.5	418	MS3080	16.90
HM3084	Tr 420 x 5	490	462	32	14	422.5	52	18	M 10 x 1.5	438	MS3084	17.40
HM3088	Tr 440 x 5	520	490	32	15	442.5	60	21	M 12 x 1.75	462	MS3088	26.20
HM3092	Tr 460 x 5	540	510	32	15	462.5	60	21	M 12 x 1.75	482	MS3092	29.60
HM3096	Tr 480 x 5	560	530	36	15	482.5	60	21	M 12 x 1.75	502	MS3096	28.30
HM30/500	Tr 500 x 5	580	550	36	15	502.5	68	21	M 12 x 1.75	522	MS30/500	33.60

⁽¹⁾Tr means 30°; trapezoid thread and the digits are major diameter of thread and pitch.

METRIC LOCKNUTS – continued

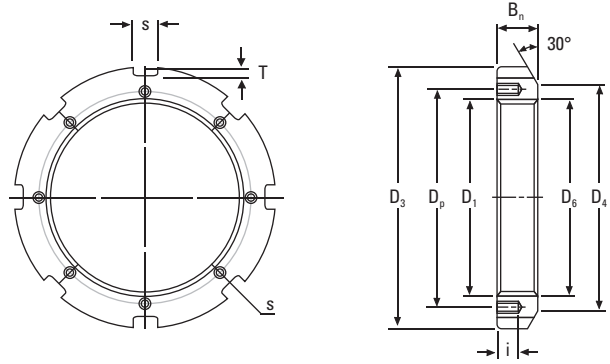

Locknut No.	Thread ⁽¹⁾ D ₁	D ₃	D ₄	s	T	D ₆	B _n	i	Tapped Hole Threads	D _p	Appropriate Lockplate No.	Weight
	mm	mm	mm	mm	mm	mm	mm	mm		mm		kg
HM3144	Tr 220 x 4	280	250	20	10	222	32	15	M 8 x 1.25	238	MS3144	5.20
HM3148	Tr 240 x 4	300	270	20	10	242	34	15	M 8 x 1.25	258	MS3148	5.95
HM3152	Tr 260 x 4	330	300	24	12	262	36	18	M 10 x 1.5	281	MS3152	8.05
HM3156	Tr 280 x 4	350	320	24	12	282	38	18	M 10 x 1.5	301	MS3156	9.05
HM3160	Tr 300 x 4	380	340	24	12	302	40	18	M 10 x 1.5	326	MS3160	11.80
HM3164	Tr 320 x 5	400	360	24	12	322.5	42	18	M 10 x 1.5	345	MS3164	13.10
HM3168	Tr 340 x 5	440	400	28	15	342.5	55	21	M 12 x 1.75	372	MS3168	23.10
HM3172	Tr 360 x 5	460	420	28	15	362.5	58	21	M 12 x 1.75	392	MS3172	25.10
HM3176	Tr 380 x 5	490	450	32	18	382.5	60	21	M 12 x 1.75	414	MS3176	30.90
HM3180	Tr 400 x 5	520	470	32	18	402.5	62	27	M 16 x 2	439	MS3180	36.90
HM3184	Tr 420 x 5	540	490	32	18	422.5	70	27	M 16 x 2	459	MS3184	43.50
HM3188	Tr 440 x 5	560	510	36	20	442.5	70	27	M 16 x 2	477	MS3188	45.30
HM3192	Tr 460 x 5	580	540	36	20	462.5	75	27	M 16 x 2	497	MS3192	50.40
HM3196	Tr 480 x 5	620	560	36	20	482.5	75	27	M 16 x 2	527	MS3196	62.20
HM31/500	Tr 500 x 5	630	580	40	23	502.5	80	27	M 16 x 2	539	MS31/500	63.30

⁽¹⁾Tr means 30°; trapezoid thread and the digits are major diameter of thread and pitch.

METRIC LOCKWASHERS

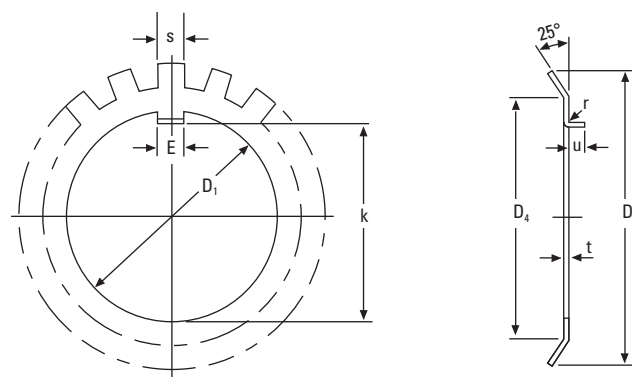

Lockwasher ⁽¹⁾ No.	Thread D ₁	k	E	t	S	D ₄	D ₅	r ⁽²⁾	u ⁽²⁾	No. of Tangs	Weight per 100 pieces	Locknut No.
	mm	mm	mm	mm	mm	mm	mm	mm	mm		kg	
MB0	10	8.5	3	1	3	13	21	0.5	2	9	0.13	KM00
MB1	12	10.5	3	1	3	17	25	0.5	2	9	0.19	KM01
MB2	15	13.5	4	1	4	21	28	1	2.5	13	0.25	KM02
MB3	17	15.5	4	1	4	24	32	1	2.5	13	0.31	KM03
MB4	20	18.5	4	1	4	26	36	1	2.5	13	0.35	KM04
MB5	25	23	5	1.2	5	32	42	1	2.5	13	0.64	KM05
MB6	30	27.5	5	1.2	5	38	49	1	2.5	13	0.78	KM06
MB7	35	32.5	6	1.2	5	44	57	1	2.5	15	1.04	KM07
MB8	40	37.5	6	1.2	6	50	62	1	2.5	15	1.23	KM08
MB9	45	42.5	6	1.2	6	56	69	1	2.5	17	1.52	KM09
MB10	50	47.5	6	1.2	6	61	74	1	2.5	17	1.60	KM10
MB11	55	52.5	8	1.2	7	67	81	1	4	17	1.96	KM11
MB12	60	57.5	8	1.5	7	73	86	1.2	4	17	2.53	KM12
MB13	65	62.5	8	1.5	7	79	92	1.2	4	19	2.90	KM13
MB14	70	66.5	8	1.5	8	85	98	1.2	4	19	3.34	KM14
MB15	75	71.5	8	1.5	8	90	104	1.2	4	19	3.56	KM15
MB16	80	76.5	10	1.8	8	95	112	1.2	4	19	4.64	KM16
MB17	85	81.5	10	1.8	8	102	119	1.2	4	19	5.24	KM17
MB18	90	86.5	10	1.8	10	108	126	1.2	4	19	6.23	KM18
MB19	95	91.5	10	1.8	10	113	133	1.2	4	19	6.70	KM19
MB20	100	96.5	12	1.8	10	120	142	1.2	6	19	7.65	KM20
MB21	105	100.5	12	1.8	12	126	145	1.2	6	19	8.26	KM21
MB22	110	105.5	12	1.8	12	133	154	1.2	6	19	9.40	KM22
MB23	115	110.5	12	2	12	137	159	1.5	6	19	10.80	KM23
MB24	120	115	14	2	12	138	164	1.5	6	19	10.50	KM24
MB25	125	120	14	2	12	148	170	1.5	6	19	11.80	KM25
MB26	130	125	14	2	12	149	175	1.5	6	19	11.30	KM26
MB27	135	130	14	2	14	160	185	1.5	6	19	14.40	KM27
MB28	140	135	16	2	14	160	192	1.5	8	19	14.20	KM28
MB29	145	140	16	2	14	171	202	1.5	8	19	16.80	KM29

⁽¹⁾No. MB0-MB40 also available in 304 stainless steel.

⁽²⁾Straight tangs when t ≥ 3 mm.

Continued on next page.

METRIC LOCKWASHERS – continued

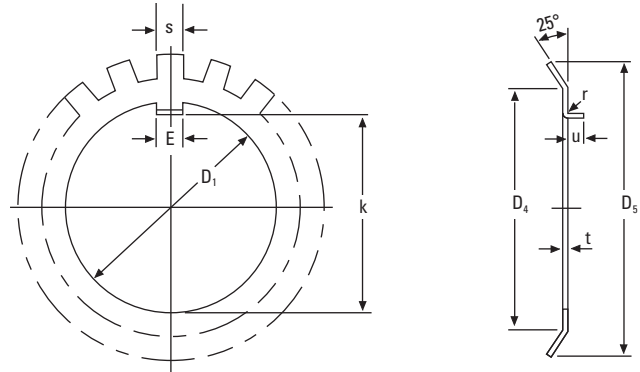

Continued from previous page.

Lockwasher ⁽¹⁾ No.	Thread D ₁	k	E	t	S	D ₄	D ₅	r ⁽²⁾	u ⁽²⁾	No. of Tangs	Weight per 100 pieces	Locknut No.
	mm	mm	mm	mm	mm	mm	mm	mm	mm		kg	
MB30	150	145	16	2	14	171	205	1.5	8	19	15.50	KM30
MB31	155	147.5	16	2.5	16	182	212	1.5	8	19	20.90	KM31
MB32	160	154	18	2.5	18	182	217	1.5	8	19	22.20	KM32
MB33	165	157.5	18	2.5	16	193	222	1.5	8	19	24.10	KM33
MB34	170	164	18	2.5	16	193	232	1.5	8	19	24.70	KM34
MB36	180	174	20	2.5	18	203	242	1.5	8	19	26.80	KM36
MB38	190	184	20	2.5	18	214	252	1.5	8	19	27.80	KM38
MB40	200	194	20	2.5	18	226	262	1.5	8	19	29.30	KM40
MB44	220	213	24	3.0	20	250	292	–	–	19	48.30	HM3144
MB48	240	233	24	3.0	20	270	312	–	–	19	50.20	HM3148
MB52	260	253	28	3.0	24	300	342	–	–	23	72.90	HM3152
MB56	280	273	28	3.0	24	320	362	–	–	23	75.90	HM3156

⁽¹⁾No. MB0-MB40 also available in 304 stainless steel.

⁽²⁾Straight tangs when t ≥ 3 mm.

METRIC LOCKPLATES

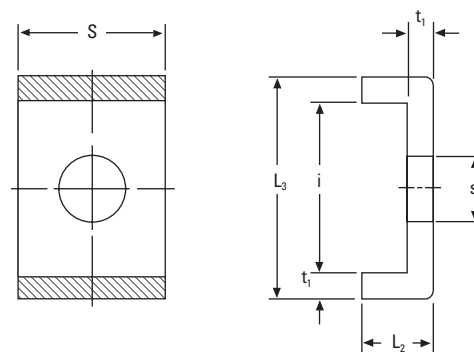

Lockplate No.	t ₁	S	L ₂	S ₁	i	L ₃	Appropriate Locknut No.	Weight per 100 pieces
	mm	mm	mm	mm	mm	mm		kg
MS3144	4	20	12	9	22.5	30.5	HM3144	2.60
MS3148	4	20	12	9	22.5	30.5	HM3148	2.60
MS3152	4	24	12	12	25.5	33.5	HM3152	3.39
MS3156	4	24	12	12	25.5	33.5	HM3156	3.39
MS3160	4	24	12	12	30.5	38.5	HM3160	3.79
MS3164	5	24	15	12	31	41	HM3164	5.35
MS3168	5	28	15	14	38	48	HM3168	6.65
MS3172	5	28	15	14	38	48	HM3172	6.65
MS3176	5	32	15	14	40	50	HM3176	7.96
MS3180	5	32	15	18	45	55	HM3180	8.20
MS3184	5	32	15	18	45	55	HM3184	8.20
MS3188	5	36	15	18	43	53	HM3188	9.00
MS3192	5	36	15	18	43	53	HM3192	9.00
MS3196	5	36	15	18	53	63	HM3196	10.40
MS31/500	5	40	15	18	45	55	HM31/500	10.50
MS3044	4	20	12	7	13.5	21.5	HM3044	2.12
MS3048	4	20	12	9	17.5	25.5	HM3048	2.29
MS3052	4	20	12	9	17.5	25.5	HM3052	2.29
MS3056	4	24	12	9	17.5	25.5	HM3056	2.92
MS3060	4	24	12	9	20.5	28.5	HM3060	3.16
MS3064	5	24	15	9	21	31	HM3064	4.56
MS3068	5	24	15	9	21	31	HM3068	4.56
MS3072	5	28	15	9	20	30	HM3072	5.03
MS3076	5	28	15	12	24	34	HM3076	5.28
MS3080	5	28	15	12	24	34	HM3080	5.28
MS3084	5	32	15	12	24	34	HM3084	6.11
MS3088	5	32	15	14	28	38	HM3088	6.45
MS3092	5	32	15	14	28	38	HM3092	6.45
MS3096	5	36	15	14	28	38	HM3096	7.29
MS30/500	5	36	15	14	28	38	HM30/500	7.29

INDEX

TIMKEN® SNT PLUMMER BLOCKS

213 Series Spherical Roller Bearings (200, 300, 500, 600 Series SNT, FSNT)	85
222 Series Spherical Roller Bearings (200, 500 Series SNT, FSNT)	86
223 Series Spherical Roller Bearings (500, 600 Series SNT, FSNT)	88
230 Series Spherical Roller Bearings (3000 Series SNT, FSNT)	89
231 Series Spherical Roller Bearings (300, 3100 Series SNT, FSNT)	90
232 Series Spherical Roller Bearings (500, 600 Series SNT, FSNT)	91
Engineering	17
Four-Bolt FSNT Housings for Cylindrical Bore Bearings	74
Four-Bolt FSNT Housings for Tapered Bore Bearings.....	66
Installation Guides	55
Large Plummer Block Housings – 3000 and 3100 Series.....	78
Metric Accessories Index.....	96
Metric H Adapter Sleeves.....	100
Metric Locknuts	108
Metric Lockwashers.....	113
Metric Lockplates.....	115
Metric OH Hydraulic Adapter Sleeves.....	104
Metric Shaft Diameters.....	82
SNT Spherical Roller Bearings Metric Accessories	93
SNT Spherical Roller Bearing Plummer Block Introduction	51
Timken® SNT Plummer Blocks.....	1
Two-Bolt SNT Housings for Cylindrical Bore Bearings.....	70
Two-Bolt SNT Housings for Tapered Bore Bearings	60

TIMKEN

The Timken team applies their know-how to improve the reliability and performance of machinery in diverse markets worldwide. The company designs, makes and markets high-performance steel as well as mechanical components, including bearings, gears, chain and related mechanical power transmission products and services.

www.timken.com



Stronger. Commitment. Stronger. Value. Stronger. Worldwide. Stronger. Together. | Stronger. By Design.

Price: USD \$75