

13 Displacements 13 Schluckvolumen 13 Cylindrée 13 Despazamientos	(8.6 to 58.5 in ³ /rev) 141 . . . 959 cm ³ /rev	
Maximum Pressure Eingangsdruck Pression entrée Presion Maxima	Cont. (3000 psid) . . . 207 bar	Int. (4000 psid) . . . 276 bar
Maximum Oil Flow Schluckstrom Débit d'huile Caudal Maximo de Aceite		(30 gpm) . . . 114 lpm
Maximum Speed Drehzahl Vitesse de rotation Velocidad Maxima		(660 rpm) 660 rpm
Maximum Torque MaxDrehmoment Couple Torque Maximo	Cont. (9,239 lb in) 1044 Nm	Int. (12,636 lb in) 1428 Nm
Maximum Side Load at Key Seitenlast Charges latérales Carga Maxima Lateral		(3597 lb) . . . 16000 N

Exceptional Strength and Durability in a High Performance Motor

The heart of Parker's TG Series powertrain, the drive link, is an extra heavy duty part that includes unique 60:40 spline geometry. Rugged construction throughout allows the transmission of up to 13,000 lb-in of torque. The entire powertrain is continually washed in cool, high flow fluid to assure long life. Roller vanes and sealed commutator maintain high efficiency and provide smooth low speed performance.

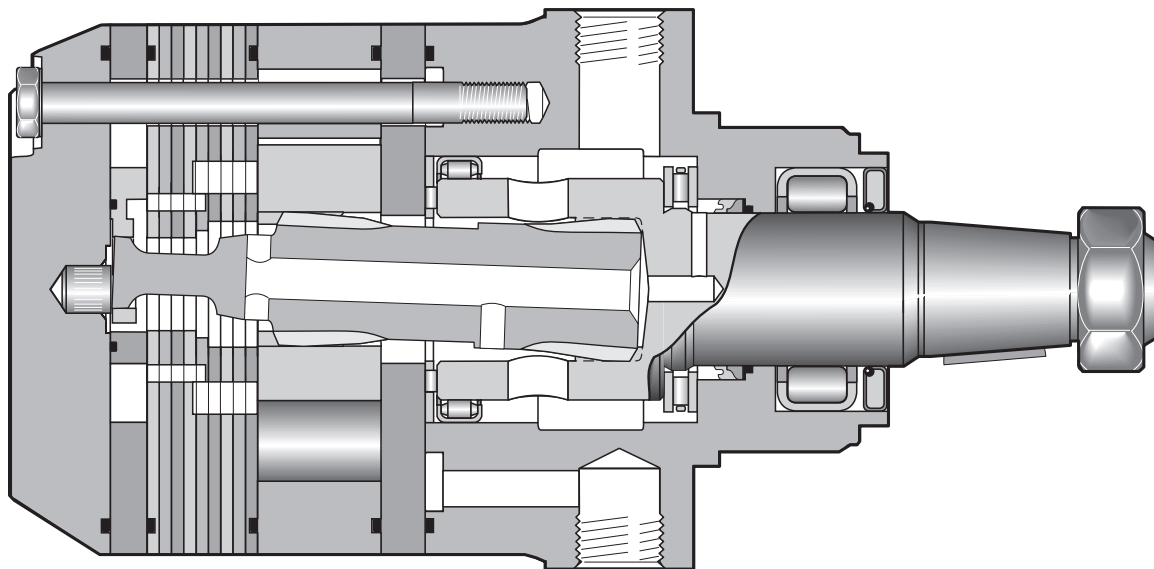
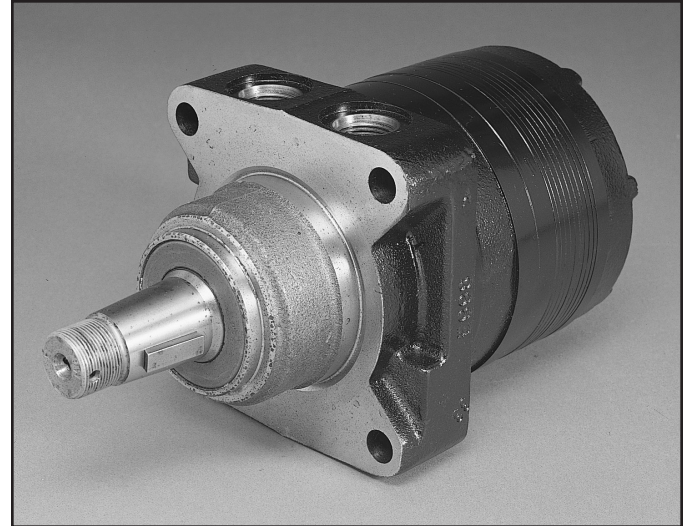

TG

Series

XXXX

Displacement
Schluckvolumen
Cylindrée
Desplazamiento

Code	cm ³ /tr cm ³ /giro cm ³ /U in ³ /rev
0140	141 / 8.6
0170	169 / 10.3
0195	195 / 11.9
0240	238 / 14.5
0280	280 / 17.1
0310	310 / 18.9
0335	337 / 20.6
0360	360 / 22.2
0405	405 / 24.7
0475	477 / 29.1
0530	528 / 32.3
0625	623 / 38.0
0785	786 / 48.0
0960	959 / 58.5

XX

Mounting/Ports
Gehäuse/Anschluß
Carter/Plan de raccordement
Montaje/Lumbreras

Code	Mounting
AS	SAE "A" 2 Bolt, 7/8-14 SAE
LS	Wheel, Front Brake, 7/8-14 SAE
MS	Magneto, 7/8-14 SAE
UB	Wheel, Standard 7/8-14 SAE O-Ring; Rear Radial
US	Wheel, Standard, 7/8-14 SAE
ZS	Four Bolt Flange, 7/8-14 O-Ring; Extended Pilot With O-Ring Groove

XX

Shaft
Welle
Arbre
Eje

Code	Shaft
01*	1" 6B Spline
03	1 1/4" Keyed
05	1 1/4" 14 Tooth Spline
08	1 1/4" Tapered
19	1 3/8" J501 Taper

Code	Mounting
EB	6 Hole Mount Deep Pilot, 7/8-14 SAE Rear Radial
HK	Wheel, Machined Pilot Nose, M6 Manifold
HW	Wheel, Machined Pilot Nose, G1/2 (1/2 BSPP) Milled Port Face
JS	Wheel, Machined Pilot Nose, 1/2 -13 UNC Tapped Holes, 7/8 O-ring ports
MB	Magneto 7/8-14 SAE O-Ring; Rear Radial
MM	Magneto, 5/16-18 UNC Manifold
RS	Wheel Mount For Ø1-1/2" shaft, 7/8-14 front ports
UE	Wheel, Standard Manifold; Rear Radial
WC	Wheel Mount. 7/8 O-ring Rear Radial w/ 2.43" Dimension To C/L
WE	Wheel, Optional Manifold; Rear Radial

Code	Shaft
02	Long Wood. Key, 1/4 Tap, Groove
06	19 Tooth Spline
17	19 T. Spline (16/32 Pitch)
20	1 3/8" Keyed
38	1.378" Special Long Straight
39	14 Tooth, Groove, 5/8 Tap
44	14 T. Spline (12/24 P.), 12mm Tap
46	32 mm Keyed
85	1 1/4", Captured Straight Keyway, No Taped Hole & No Ring Groove
86	1 1/4" With Captured Straight Keyway, No Taped Hole & No Ring Groove

Custom Order

Shaded areas indicate custom order components. Standard pricing and delivery terms may not apply to these components. Please refer to the price list for details, or consult your Parker Pump Motor division Sales Resource.

* Conforms to SAE recommended length

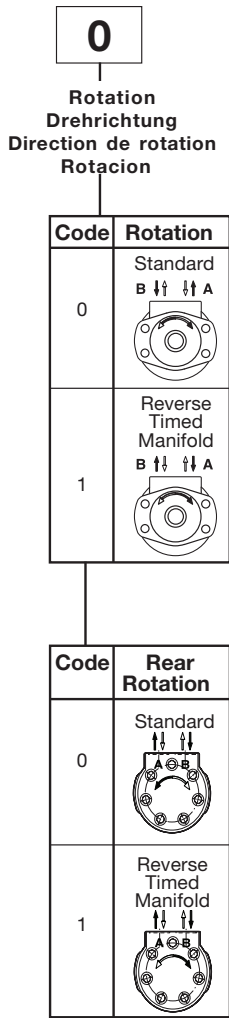

Rotation viewed
from shaft end.

XXXX

Options
Opciones

Code	Options
AAAA	"Standard", Black Paint (045134), Paint area all over except front and rear pilot and mounting flanges and shaft
AAAB	"Standard", No Paint
AAAC	"Standard", Double Paint (045247), Paint area all over except front and rear pilot and mounting flanges and shaft
AABJ	Free Running Rotor Set, Black paint (045134), Paint area all over except front and rear pilot and mounting flanges and shaft
AABT	Black paint (045134), Paint area all over except front and rear pilot and mounting flanges and shaft, No shaft hardware
AAFA	Fluorocarbon (Viton) Seals, High Temp Commutator Seal, No paint
AAFW	Fluorocarbon (Viton) Seals, High Temp Commutator Seal, Black paint (045134), Paint area all over except front and rear pilot and mounting flanges and shaft
AAJH	Fluorocarbon (Viton) Seals, High Temp Commutator Seal, Black paint (045134), Paint area all over except front and rear pilot and mounting flanges and shaft, No shaft hardware
AAJL	No paint, No shaft hardware
AAUP	Fluorocarbon (Viton) Seals, High Temp Commutator Seal, No Paint, No shaft Hardware
AAVE	Free Running Rotor Set, Fluorocarbon (Viton) Seals, High Temp Commutator Seal, Black Paint (045134), Paint area all over except front and rear pilot and mounting flanges and shaft
ABCW	Fluorocarbon (Viton) Seals, High Temperature Commutator Seal, Bidirectional shuttle (.062 Orifice) (1:1:00*), Black Paint (045134), Paint area all over except front and rear pilot and mounting flanges and shaft, No Shaft Hardware
ABCZ	Fluorocarbon (Viton) Seals, Double paint (045247), Paint area all over except front and rear pilot and mounting flanges and shaft
BBGV	Fluorocarbon (Viton) Seals, High Temperature Commutator Seal, 1015 PSI Int Bidirectional Relief, Black Paint (045134), Paint area all over except front and rear pilot and mounting flanges and shaft, No Shaft Hardware
BBGW	Fluorocarbon (Viton) Seals, High Temperature Commutator Seal, 1450 PSI Int Bidirectional Relief, Black Paint (045134), Paint area all over except front and rear pilot and mounting flanges and shaft, No Shaft Hardware
BBGX	No Shaft Hardware, Fluorocarbon (Viton) Seals, High Temperature Commutator Seal, 2031 PSI Int Bidirectional Relief, Black Paint (045134), Paint area all over except front and rear pilot and mounting flanges and shaft, No Shaft Hardware
BBGY	Fluorocarbon (Viton) Seals, High Temperature Commutator Seal, 3046 PSI Int Bidirectional Relief, Black Paint (045134), Paint area all over except front and rear pilot and mounting flanges and shaft, No Shaft Hardware
BBGZ	Fluorocarbon (Viton) Seals, High Temperature Commutator Seal, 4061 PSI Int Bidirectional Relief, Black Paint (045134), Paint area all over except front and rear pilot and mounting flanges and shaft, No Shaft Hardware
BBHC	Fluorocarbon (Viton) Seals, High Temperature Commutator Seal, 725 PSI Int Bidirectional Relief, Black Paint (045134), Paint area all over except front and rear pilot and mounting flanges and shaft, No Shaft Hardware
BBHD	Fluorocarbon (Viton) Seals, High Temperature Commutator Seal, 2538 PSI Int Bidirectional Relief, Black Paint (045134), Paint area all over except front and rear pilot and mounting flanges and shaft, No Shaft Hardware
FSEK	Fluorocarbon (Viton) Seals, High Temperature Commutator Seal, Parker ECD Speed Sensor (455073), Black Paint (045134), Paint area all over except front and rear pilot and mounting flanges and shaft, No Shaft Hardware
FSEN	Fluorocarbon (Viton) Seals, High Temperature Commutator Seal, Parker ECD Speed Sensor (455073), No Paint, No Shaft Hardware

* Abtriebswelle Ø 25mm Max.Moment cont./int. }
Coupling shaft Ø 1 inch Max.torque cont./int. 450/550 Nm
Arbre 6B SAE Couple maxi cont./int.
Eje de acople Coppia max cont./int.

Shaded areas indicate custom order components. Standard pricing and delivery terms may not apply to these components. Please refer to the price list for details, or consult your Parker Pump Motor division Sales Resource.

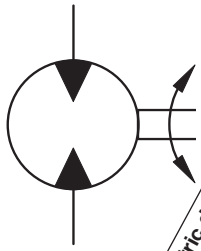

Geometric displacement
Geom. Schluckvolumen
Cylindrée
Cilindrata
Max. speed @ Max. intermittent flow
Max. Drehzahl / Intermittierender Betrieb:
Vitesse de rotation maxi
Velocidad maxima a caudal intermitente maximo
Max. oil flow
Max. Schluckstrom
Portata max
Max. differential pressure
Max. Druckgefälle
Chute de pression maxi
Presion diferencial maxima
Max. supply pressure
Max. Eingangsdruck
Presion maxi entrée
Presion maxima de alimentacion
Max. torque
Max. Drehmoment
Couple maxi
Torque Maximo
Max. performance
Max. Leistungabgabe
Puissance de sortie maxi
Potenza meccanica max
Min. starting torque
Min. Anlaufmoment
Couple min. fourni au ds manrage
Torque minimo de arranque

Motor Series TG	cm ³ /rev in ³ /rev	rev/min	cont / int*		cont / int*		max			cont / int*		max		cont / int*	
			l/min	bar	bar	psig	bar	Nm	KW	Nm	HP	Nm	lb-in	lb-in	lb-in
			g/min	psid	psig		psig	lb-in	HP	lb-in		lb-in			
TG 0140	141 8.6	660	76 95 20 25	207 276 3000 4000	300	4350	390 530 3455 4692	33 418 2791 3706	33 45	315 418 2791 3706	33 45	315 418 2791 3706	315 418 2791 3706	315 418 2791 3706	315 418 2791 3706
TG 0170	169 10.3	554	76 95 20 25	207 276 3000 4000	300	4350	476 646 4216 5714	33 505 3331 4469	33 45	376 505 3331 4469	33 45	376 505 3331 4469	376 505 3331 4469	376 505 3331 4469	376 505 3331 4469
TG 0195	195 11.9	477	76 95 20 25	207 276 3000 4000	300	4350	556 753 4919 6663	33 611 3989 5408	33 45	451 611 3989 5408	33 45	451 611 3989 5408	451 611 3989 5408	451 611 3989 5408	451 611 3989 5408
TG 0240	238 14.5	393	76 95 20 25	207 276 3000 4000	300	4350	677 913 5991 8081	32 776 5152 6865	32 44	582 776 5152 6865	32 44	582 776 5152 6865	582 776 5152 6865	582 776 5152 6865	582 776 5152 6865
TG 0280	280 17.1	334	76 95 20 25	207 276 3000 4000	300	4350	796 1073 7044 9499	31 870 5972 7699	31 42	675 870 5972 7699	31 42	675 870 5972 7699	675 870 5972 7699	675 870 5972 7699	675 870 5972 7699
TG 0310	310 18.9	303	76 95 20 25	207 276 3000 4000	300	4350	924 1229 8184 10817	31 1005 6882 8893	31 41	778 1005 6882 8893	31 41	778 1005 6882 8893	778 1005 6882 8893	778 1005 6882 8893	778 1005 6882 8893
TG 0335	337 20.6	277	76 95 20 25	207 276 3000 4000	300	4350	964 1297 8533 11479	30 1117 7458 9889	30 41	843 1117 7458 9889	30 41	843 1117 7458 9889	843 1117 7458 9889	843 1117 7458 9889	843 1117 7458 9889
TG 0360	360 22.2	259	76 95 20 25	172 241 2500 3500	300	4350	894 1254 7913 11093	29 1017 6224 9007	29 39	703 1017 6224 9007	29 39	703 1017 6224 9007	703 1017 6224 9007	703 1017 6224 9007	703 1017 6224 9007
TG 0405	405 24.7	232	76 95 20 25	172 241 2500 3500	300	4350	942 1342 8336 11877	27 1145 7002 10133	27 37	791 1145 7002 10133	27 37	791 1145 7002 10133	791 1145 7002 10133	791 1145 7002 10133	791 1145 7002 10133
TG 0475	477 29.1	237	76 114 20 30	138 207 2000 3000	300	4350	887 1372 7853 12145	28 1120 6549 9909	28 38	740 1120 6549 9909	28 38	740 1120 6549 9909	740 1120 6549 9909	740 1120 6549 9909	740 1120 6549 9909
TG 0530	528 32.3	213	76 114 20 30	138 172 2000 2500	300	4350	983 1253 8701 11086	23 1091 7737 9657	23 31	874 1091 7737 9657	23 31	874 1091 7737 9657	874 1091 7737 9657	874 1091 7737 9657	874 1091 7737 9657
TG 0625	623 38.0	182	76 114 20 30	121 155 1750 2250	300	4350	986 1291 8727 11424	20 1165 7924 10312	20 27	895 1165 7924 10312	20 27	895 1165 7924 10312	895 1165 7924 10312	895 1165 7924 10312	895 1165 7924 10312
TG 0785	786 48.0	143	76 114 20 30	103 138 1500 2000	300	4350	1044 1428 9239 12636	17 1341 8772 11876	17 23	991 1341 8772 11876	17 23	991 1341 8772 11876	991 1341 8772 11876	991 1341 8772 11876	991 1341 8772 11876
TG 0960	959 58.5	118	76 114 20 30	69 103 1000 1500	300	4350	773 1268 6843 11227	12 1177 6752 10419	12 16	763 1177 6752 10419	12 16	763 1177 6752 10419	763 1177 6752 10419	763 1177 6752 10419	763 1177 6752 10419

Performance data based on testing using 10W40 oil with a viscosity of 200 SUS at 54° C (130° F). Performance data is typical. Actual data may vary slightly from one production motor to another.

Les donnees sur les performances sont basees sur des tests utilisant de l'huile 10W40 d'une viscosite de 200 SUS a 54°C (130°F). Ces donnees correspondent a des situations typiques. Les donnees reelles peuvent varier legerement d'un moteur de production a l'autre.

Leistungsdaten sind gemessen mit SAE 10W40 bei einer Viskositatet von 43,1 Cst bei 54°C. Geringfuegige Abweichungen von den Katalogdaten sind moeglich.

Datos tecnicos obtenidos con aceite 10W40 de 200 SUS de viscosidad a 54°C (130°F). Los datos proporcionados son valores tipicos. Los valores exactos reales podrian tener una pequena variacion entre distintos motores.

* Intermittent operation rating applies to 10% of every minute.
Intermittierende Werte maximal 10% von jeder Betriebsminute.
Fonctionnement interm. 10% max. de chaque minute d'utilisation.
Capacidad de funcionamiento intermitente valida para 10% por cada minuto.



TG 0140

8.6 cu in / rev

PRESSURE (PSID)

	500	1000	1500	2000	2500	3000	3500	4000
.5	519 9	1060 4						
1	540 22	1090 17	1635 11	2180 6				
2	569 49	1156 43	1730 36	2286 30	2827 23	3368 19	3899 12	4447 12
3	565 75	1159 69	1744 62	2321 55	2899 47	3477 40	4048 33	4608 29
4	564 102	1170 94	1768 87	2358 80	2943 72	3517 64	4082 57	4644 52
5	556 128	1170 120	1776 112	2375 105	2968 97	3556 89	4135 81	4701 76
7	540 182	1160 172	1779 164	2390 155	2994 146	3592 138	4181 130	4763 123
9	515 235	1143 225	1768 215	2385 206	2996 196	3601 187	4199 179	4794 171
12	471 315	1096 303	1729 292	2356 281	2974 271	3587 261	4193 252	4794 243
15	418 395	1042 381	1673 368	2307 357	2933 346	3549 336	4163 325	4771 314
20	299 528	931 512	1565 497	2198 484	2825 472	3455 459	4078 447	4692 435
25	173 660	794 643	1426 626	2059 612	2695 598	3332 583	3961 569	4579 555

Flow (GPM)

TORQUE (LB IN) 3961
 SPEED (RPM) 569

Cont. Int.

Intermittent operation rating applies to 10% of every minute.

Fonctionnement interm. 10% max. de chaque minute d'utilisation.

Performance data based on testing using 10W40 oil with a viscosity of 200 SUS at 54° C (130° F). Performance data is typical. Actual data may vary slightly from one production motor to another.

Les donnees sur les performances sont basees sur des tests utilisant de l'huile 10W40 d'une viscosite de 200 SUS a 54°C (130°F). Ces donnees correspondent a des situations typiques. Les donnees reelles peuvent varier legerement d'un moteur de production a l'autre.

011 TG.indd, b

Intermittierende Werte maximal 10% von jeder Betriebsminute.

Capacidad de funcionamiento intermitente valida para 10% por cada minuto. Leistungsdaten sind gemessen mit SAE 10W40 bei einer Viskositat von 43,1 Cst bei 54°C. Geringfuegige Abweichungen von den Katalogdaten sind moeglich.

Datos tecnicos obtenidos con aceite 10W40 de 200 SUS de viscosidad a 54°C (130°F). Los datos proporcionados son valores tipcos. Los valores exactos reales podrian tener una pequena variacion entre distintos motores.



WARNING
 This product can expose you to chemicals including lead and DEHP, which are known to the State of California to cause cancer, and birth defects or other reproductive harm. For more information go to www.p65warnings.ca.gov

Parker Hannifin Corporation
 Pump & Motor Division
 Greeneville, Tennessee, USA

TG 0170

10.3 cu in / rev

	PRESSURE (PSID)							
	500	1000	1500	2000	2500	3000	3500	4000
.5	620 9	1284 7	1945 5	2613 4	3293 3	3983 2		
1	652 20	1337 18	2006 16	2683 14	3375 12	4063 11	4744 8	5402 8
2	678 42	1390 40	2105 37	2822 35	3535 32	4226 30	4909 27	5587 25
3	678 64	1397 61	2117 58	2836 56	3554 53	4263 50	4963 46	5652 44
4	679 86	1409 83	2142 80	2872 77	3596 74	4310 71	5021 67	5716 64
5	675 108	1413 104	2150 101	2885 98	3616 94	4339 91	5057 87	5761 83
7	661 153	1405 148	2152 143	2900 140	3642 136	4374 132	5101 127	5818 123
9	632 197	1385 191	2140 186	2891 181	3638 177	4380 173	5114 168	5838 163
12	583 263	1334 256	2096 250	2860 244	3617 239	4362 234	5101 228	5823 223
15	524 330	1275 322	2035 314	2804 308	3572 302	4327 296	5070 289	5801 283
20	382 442	1143 432	1908 422	2683 413	3455 406	4216 399	4972 391	5714 383
25	239 554	983 543	1747 531	2523 520	3299 511	4071 501	4839 492	5591 483

Flow (GPM)

TORQUE (LB IN) 4839
 SPEED (RPM) 492

Cont. Int.

Intermittent operation rating applies to 10% of every minute.
 Fonctionnement interm. 10% max. de chaque minute d'utilisation.
 Performance data based on testing using 10W40 oil with a viscosity of 200 SUS at 54° C (130° F). Performance data is typical. Actual data may vary slightly from one production motor to another.

Les donnees sur les performances sont basees sur des tests utilisant de l'huile 10W40 d'une viscosite de 200 SUS a 54°C (130°F). Ces donnees correspondent a des situations typiques. Les donnees reelles peuvent varier legerement d'un moteur de production a l'autre.

011 TG.indd, b

Intermittierende Werte maximal 10% von jeder Betriebsminute.
 Capacidad de funcionamiento intermitente valida para 10% por cada minuto.
 Leistungsdaten sind gemessen mit SAE 10W40 bei einer Viskositat von 43,1 Cst bei 54°C. Geringfuegige Abweichungen von den Katalogdaten sind moeglich.

Datos tecnicos obtenidos con aceite 10W40 de 200 SUS de viscosidad a 54°C (130°F). Los datos proporcionados son valores tipcos. Los valores exactos reales podrian tener una pequena variacion entre distintos motores.



WARNING
 This product can expose you to chemicals including lead and DEHP, which are known to the State of California to cause cancer, and birth defects or other reproductive harm. For more information go to www.p65warnings.ca.gov

Parker Hannifin Corporation
 Pump & Motor Division
 Greeneville, Tennessee, USA

TG 0195

11.9 cu in / rev

PRESSURE (PSID)

	500	1000	1500	2000	2500	3000	3500	4000
.5	733 7	1503 3						
1	761 16	1546 13	2326 8	3104 3				
2	799 35	1638 32	2465 27	3270 21	4046 16	4813 11	5589 7	6375 6
3	794 55	1639 50	2476 45	3303 39	4132 34	4970 28	5792 23	6595 19
4	794 74	1654 69	2509 64	3356 58	4196 52	5023 46	5830 40	6635 35
5	783 93	1653 88	2517 83	3375 76	4224 70	5065 64	5895 58	6710 52
7	762 131	1637 126	2514 120	3384 113	4245 106	5098 99	5940 92	6772 86
9	731 170	1616 164	2499 157	3373 150	4239 142	5093 135	5936 127	6774 120
12	677 228	1562 221	2455 213	3343 205	4217 196	5081 188	5934 179	6776 172
15	613 285	1498 278	2389 269	3283 260	4169 251	5040 242	5907 232	6765 233
20	448 381	1350 373	2245 363	3141 353	4031 342	4919 331	5798 321	6663 310
25	334 477	1158 468	2044 457	2941 445	3837 433	4729 421	5612 409	6500 397

Flow (GPM)

TORQUE (LB IN) 5612
 SPEED (RPM) 409

Cont. Int.

Intermittent operation rating applies to 10% of every minute.
 Fonctionnement interm. 10% max. de chaque minute d'utilisation.
 Performance data based on testing using 10W40 oil with a viscosity of 200 SUS at 54° C (130° F). Performance data is typical. Actual data may vary slightly from one production motor to another.
 Les donnees sur les performances sont basees sur des tests utilisant de l'huile 10W40 d'une viscosite de 200 SUS a 54°C (130°F). Ces donnees correspondent a des situations typiques. Les donnees reelles peuvent varier legerement d'un moteur de production a l'autre.

Intermittierende Werte maximal 10% von jeder Betriebsminute.
 Capacidad de funcionamiento intermitente valida para 10% por cada minuto.
 Leistungsdaten sind gemessen mit SAE 10W40 bei einer Viskositat von 43,1 Cst bei 54°C. Geringfuegige Abweichungen von den Katalogdaten sind moeglich.
 Datos tecnicos obtenidos con aceite 10W40 de 200 SUS de viscosidad a 54°C (130°F). Los datos proporcionados son valores tipcos. Los valores exactos reales podrian tener una pequena variacion entre distintos motores.

011 TG.indd, b



WARNING
 This product can expose you to chemicals including lead and DEHP, which are known to the State of California to cause cancer, and birth defects or other reproductive harm. For more information go to www.p65warnings.ca.gov

Parker Hannifin Corporation
 Pump & Motor Division
 Greeneville, Tennessee, USA

TG 0240

14.5 cu in / rev

PRESSURE (PSID)

	500	1000	1500	2000	2500	3000	3500	4000
.5	932 6	1907 4	2894 2					
1	960 14	1954 12	2950 9	3943 6	4939 3	5930 2		
2	988 30	2031 27	3065 24	4090 20	5107 17	6100 14	7068 11	8037 9
3	983 45	2029 42	3071 39	4101 35	5128 31	6161 27	7182 23	8184 20
4	978 61	2037 58	3090 54	4136 49	5176 45	6207 42	7230 37	8234 33
5	962 77	2030 73	3092 69	4144 64	5190 60	6231 56	7259 51	8271 47
7	933 108	2005 104	3078 99	4141 94	5194 89	6239 84	7275 78	8298 73
9	890 140	1972 135	3048 129	4112 123	5169 117	6213 112	7245 106	8271 100
12	832 187	1912 181	2996 175	4071 167	5125 161	6163 154	7195 147	8224 140
15	753 235	1832 228	2921 220	4009 212	5081 204	6137 196	7182 188	8212 180
20	559 314	1654 306	2744 297	3834 287	4917 278	5991 268	7045 258	8081 248
25	524 393	1427 384	2507 373	3595 363	4690 352	5780 340	6853 328	7913 317

Flow (GPM)

Cont. Int.

Intermittent operation rating applies to 10% of every minute.

Fonctionnement interm. 10% max. de chaque minute d'utilisation.

Performance data based on testing using 10W40 oil with a viscosity of 200 SUS at 54° C (130° F). Performance data is typical. Actual data may vary slightly from one production motor to another.

Les donnees sur les performances sont basees sur des tests utilisant de l'huile 10W40 d'une viscosite de 200 SUS a 54°C (130°F). Ces donnees correspondent a des situations typiques. Les donnees reelles peuvent varier legerement d'un moteur de production a l'autre.

011 TG.indd, b

Intermittierende Werte maximal 10% von jeder Betriebsminute.

Capacidad de funcionamiento intermitente valida para 10% por cada minuto.

Leistungsdaten sind gemessen mit SAE 10W40 bei einer Viskosität von 43,1 Cst bei 54°C. Geringfügige Abweichungen von den Katalogdaten sind möglich.

Datos tecnicos obtenidos con aceite 10W40 de 200 SUS de viscosidad a 54°C (130°F). Los datos proporcionados son valores tipicos. Los valores exactos reales podrian tener una pequena variacion entre distintos motores.



WARNING
This product can expose you to chemicals including lead and DEHP, which are known to the State of California to cause cancer, and birth defects or other reproductive harm. For more information go to www.p65warnings.ca.gov

Parker Hannifin Corporation
Pump & Motor Division
Greeneville, Tennessee, USA

TG 0280

17.1 cu in / rev

	PRESSURE (PSID)							
	500	1000	1500	2000	2500	3000	3500	4000
.5	1056 5	2177 4	3323 2	4512 1				
1	1087 12	2223 10	3378 8	4552 6	5734 5	6930 3	8135 3	9350 2
2	1124 25	2313 23	3513 21	4700 18	5880 16	7060 14	8239 12	9400 11
3	1124 39	2323 36	3532 34	4740 31	5940 28	7143 25	8346 22	9536 19
4	1126 52	2346 49	3568 47	4786 43	6004 40	7214 37	8415 33	9596 30
5	1115 65	2350 62	3582 59	4816 56	6044 52	7256 49	8457 45	9641 41
7	1091 92	2338 88	3586 85	4832 80	6072 76	7301 72	8515 67	9706 63
9	1046 118	2309 114	3564 110	4811 105	6051 101	7280 96	8499 90	9707 85
12	981 159	2242 154	3506 148	4757 143	5992 137	7221 132	8444 125	9652 118
15	898 199	2164 193	3437 186	4702 180	5951 174	7187 168	8416 160	9625 152
20	691 266	1976 258	3255 250	4529 243	5795 235	7044 227	8275 218	9499 209
25	703 334	1726 324	2987 314	4260 305	5540 296	6815 286	8071 276	9311 267

Flow (GPM)

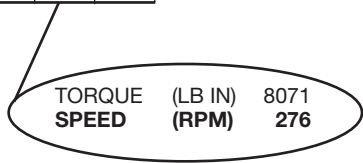

Cont. Int.

Intermittent operation rating applies to 10% of every minute.
 Fonctionnement interm. 10% max. de chaque minute d'utilisation.
 Performance data based on testing using 10W40 oil with a viscosity of 200 SUS at 54° C (130° F). Performance data is typical. Actual data may vary slightly from one production motor to another.
 Les donnees sur les performances sont basees sur des tests utilisant de l'huile 10W40 d'une viscosite de 200 SUS a 54°C (130°F). Ces donnees correspondent a des situations typiques. Les donnees reelles peuvent varier legerement d'un moteur de production a l'autre.

Intermittierende Werte maximal 10% von jeder Betriebsminute.
 Capacidad de funcionamiento intermitente valida para 10% por cada minuto.
 Leistungsdaten sind gemessen mit SAE 10W40 bei einer Viskositat von 43,1 Cst bei 54°C. Geringfuegige Abweichungen von den Katalogdaten sind moeglich.
 Datos tecnicos obtenidos con aceite 10W40 de 200 SUS de viscosidad a 54°C (130°F). Los datos proporcionados son valores tipcos. Los valores exactos reales podrian tener una pequena variacion entre distintos motores.

011 TG.indd, b



WARNING
 This product can expose you to chemicals including lead and DEHP, which are known to the State of California to cause cancer, and birth defects or other reproductive harm. For more information go to www.p65warnings.ca.gov

Parker Hannifin Corporation
 Pump & Motor Division
 Greeneville, Tennessee, USA

TG 0310

18.9 cu in / rev

PRESSURE (PSID)

	500	1000	1500	2000	2500	3000	3500	4000
.5	1188 4	2464 3	3766 2	5102 1				
1	1220 11	2508 9	3812 7	5145 5	6477 4	7822 2	9181 2	10530 1
2	1259 23	2598 21	3950 19	5298 17	6642 14	7972 13	9282 10	10574 9
3	1257 35	2606 33	3889 30	5332 28	6688 25	8044 22	9392 19	10693 16
4	1259 47	2628 44	4003 42	5377 39	6749 36	8114 33	9461 29	10780 26
5	1247 59	2629 56	4252 52	5401 50	6782 47	8149 42	9499 39	10823 35
7	1218 84	2614 80	4013 76	5413 72	6806 68	8184 64	9543 60	10874 56
9	1167 107	2574 103	3983 99	5386 94	6780 90	8162 85	9529 80	10877 75
12	1089 143	2493 139	3904 133	5308 128	6696 122	8075 117	9443 110	10793 102
15	995 180	2400 173	3817 167	5225 160	6621 154	8003 148	9371 140	10718 131
20	769 241	2194 234	3618 225	5043 218	6462 210	7863 203	9238 194	10588 183
25	626 303	1955 294	3359 284	4771 274	6251 265	7608 256	8998 246	10360 236

Flow (GPM)

TORQUE (LB IN) 7608
 SPEED (RPM) 256

Cont. Int.

Intermittent operation rating applies to 10% of every minute.
 Fonctionnement interm. 10% max. de chaque minute d'utilisation.
 Performance data based on testing using 10W40 oil with a viscosity of 200 SUS at 54° C (130° F). Performance data is typical. Actual data may vary slightly from one production motor to another.
 Les donnees sur les performances sont basees sur des tests utilisant de l'huile 10W40 d'une viscosite de 200 SUS a 54°C (130°F). Ces donnees correspondent a des situations typiques. Les donnees reelles peuvent varier legerement d'un moteur de production a l'autre.

Intermittierende Werte maximal 10% von jeder Betriebsminute.
 Capacidad de funcionamiento intermitente valida para 10% por cada minuto.
 Leistungsdaten sind gemessen mit SAE 10W40 bei einer Viskositat von 43,1 Cst bei 54°C. Geringfuegige Abweichungen von den Katalogdaten sind moeglich.
 Datos tecnicos obtenidos con aceite 10W40 de 200 SUS de viscosidad a 54°C (130°F). Los datos proporcionados son valores tipcos. Los valores exactos reales podrian tener una pequena variacion entre distintos motores.

011 TG.indd, b



WARNING
 This product can expose you to chemicals including lead and DEHP, which are known to the State of California to cause cancer, and birth defects or other reproductive harm. For more information go to www.p65warnings.ca.gov

Parker Hannifin Corporation
 Pump & Motor Division
 Greeneville, Tennessee, USA

TG 0335

20.6 cu in / rev

PRESSURE (PSID)

	500	1000	1500	2000	2500	3000	3500	4000
.5	1297 4	2699 3	4128 1	5584 1				
1	1329 10	2741 8	4176 7	5630 5	7084 4	8551 2	10036 2	11496 1
2	1369 21	2832 19	4308 17	5787 15	7265 13	8718 11	10136 9	11534 8
3	1366 32	2838 30	4326 27	5817 25	7301 22	8781 20	10248 17	11685 14
4	1368 43	2858 40	4358 38	5861 35	7358 32	8850 29	10317 25	11748 22
5	1355 54	2858 51	4368 48	5880 45	7386 42	8880 38	10352 34	11791 30
7	1323 76	2840 73	4363 69	5888 65	7407 61	8908 57	10384 53	11829 47
9	1266 98	2791 94	4326 90	5856 85	7376 81	8884 76	10372 71	11834 64
12	1177 131	2698 127	4230 121	5759 116	7273 110	8773 105	10261 98	11726 90
15	1075 165	2594 159	4127 153	5654 146	7170 140	8670 134	10153 126	11613 116
20	833 221	2372 214	3915 205	5463 197	7008 189	8533 182	10026 173	11479 161
25	678 277	2142 269	3663 259	5189 248	6726 239	8257 230	9757 219	11219 209

Flow (GPM)

TORQUE (LB IN) 8257
SPEED (RPM) 230

Cont. Int.

Intermittent operation rating applies to 10% of every minute.
 Fonctionnement interm. 10% max. de chaque minute d'utilisation.
 Performance data based on testing using 10W40 oil with a viscosity of 200 SUS at 54° C (130° F). Performance data is typical. Actual data may vary slightly from one production motor to another.
 Les donnees sur les performances sont basees sur des tests utilisant de l'huile 10W40 d'une viscosite de 200 SUS a 54°C (130°F). Ces donnees correspondent a des situations typiques. Les donnees reelles peuvent varier legerement d'un moteur de production a l'autre.

Intermittierende Werte maximal 10% von jeder Betriebsminute.
 Capacidad de funcionamiento intermitente valida para 10% por cada minuto.
 Leistungsdaten sind gemessen mit SAE 10W40 bei einer Viskositat von 43,1 Cst bei 54°C. Geringfuegige Abweichungen von den Katalogdaten sind moeglich.
 Datos tecnicos obtenidos con aceite 10W40 de 200 SUS de viscosidad a 54°C (130°F). Los datos proporcionados son valores tipcos. Los valores exactos reales podrian tener una pequena variacion entre distintos motores.

011 TG.indd, b



WARNING
 This product can expose you to chemicals including lead and DEHP, which are known to the State of California to cause cancer, and birth defects or other reproductive harm. For more information go to www.p65warnings.ca.gov

Parker Hannifin Corporation
 Pump & Motor Division
 Greeneville, Tennessee, USA

TG 0360

360 cm³ / rev (22.2 in³ / rev)

PRESSURE (PSID)

	500	1000	1500	2000	2500	3000	3500
.5	1386 4	2883 3	4410 1	5965 1			
1	1420 9	2928 7	4461 7	6014 5	7567 4	9135 2	10721 2
2	1462 20	3025 18	4602 16	6182 14	7761 12	9313 10	10828 8
3	1459 30	3031 28	4621 25	6214 23	7799 21	9380 19	10947 16
4	1461 40	3053 37	4655 36	6261 33	7884 30	9454 27	11021 23
5	1447 51	3053 48	4666 45	6281 42	7890 39	9486 36	11059 32
7	1413 71	3034 68	4661 65	6290 61	7913 57	9516 53	11093 50
9	1352 92	2981 88	4621 84	6256 80	7879 76	9490 71	11080 66
12	1257 123	2882 119	4519 113	6152 109	7769 103	9372 98	10961 92
15	1148 154	2771 149	4409 143	6040 137	7659 131	9262 125	10846 118
20	890 207	2534 200	4182 192	5836 184	7486 177	9115 170	10710 162
25	724 259	2288 252	3913 242	5543 232	7185 224	8821 215	10423 205

Flow (GPM)

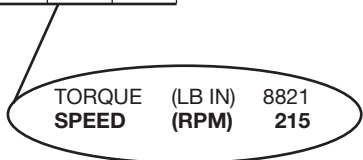

Cont. Int.

Intermittent operation rating applies to 10% of every minute.
 Fonctionnement interm. 10% max. de chaque minute d'utilisation.
 Performance data based on testing using 10W40 oil with a viscosity of 200 SUS at 54° C (130° F). Performance data is typical. Actual data may vary slightly from one production motor to another.

Les donnees sur les performances sont basees sur des tests utilisant de l'huile 10W40 d'une viscosite de 200 SUS a 54°C (130°F). Ces donnees correspondent a des situations typiques. Les donnees reelles peuvent varier legerement d'un moteur de production a l'autre.

011 TG.indd, b

Intermittierende Werte maximal 10% von jeder Betriebsminute.
 Capacidad de funcionamiento intermitente valida para 10% por cada minuto.
 Leistungsdaten sind gemessen mit SAE 10W40 bei einer Viskositat von 43,1 Cst bei 54°C. Geringfuegige Abweichungen von den Katalogdaten sind moeglich.
 Datos tecnicos obtenidos con aceite 10W40 de 200 SUS de viscosidad a 54°C (130°F). Los datos proporcionados son valores tipcos. Los valores exactos reales podrian tener una pequena variacion entre distintos motores.



WARNING
 This product can expose you to chemicals including lead and DEHP, which are known to the State of California to cause cancer, and birth defects or other reproductive harm. For more information go to www.p65warnings.ca.gov

Parker Hannifin Corporation
 Pump & Motor Division
 Greeneville, Tennessee, USA

TG 0405

24.7 cu in / rev

	PRESSURE (PSID)						
	500	1000	1500	2000	2500	3000	3500
.5	1544 4	3178 3	4840 2	6515 1	8185 1		
1	1593 8	3256 7	4928 6	6607 6	8303 5	9987 4	11652 3
2	1636 17	3351 16	5084 15	6817 14	8550 13	10272 12	11978 11
3	1637 27	3365 25	5106 23	6847 22	8588 21	10314 19	12031 18
4	1645 36	3394 34	5159 32	6920 30	8668 29	10402 27	12130 26
5	1640 45	3408 43	5201 41	6983 39	8733 37	10466 35	12194 33
7	1606 64	3396 61	5211 59	7003 56	8772 54	10527 51	12271 49
9	1551 82	3350 80	5176 77	6981 73	8763 70	10519 67	12269 64
12	1428 110	3238 107	5075 103	6888 99	8670 95	10424 91	12172 88
15	1310 138	3112 135	4948 130	6759 125	8545 120	10306 115	12060 111
20	1136 185	2862 181	4692 175	6518 168	8336 162	10122 156	11877 151
25			4492 219	6303 212	8084 204	9848 197	11585 190

Flow (GPM)

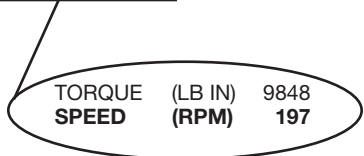

Cont. Int.

Intermittent operation rating applies to 10% of every minute.
 Fonctionnement interm. 10% max. de chaque minute d'utilisation.
 Performance data based on testing using 10W40 oil with a viscosity of 200 SUS at 54° C (130° F). Performance data is typical. Actual data may vary slightly from one production motor to another.

Les donnees sur les performances sont basees sur des tests utilisant de l'huile 10W40 d'une viscosite de 200 SUS a 54°C (130°F). Ces donnees correspondent a des situations typiques. Les donnees reelles peuvent varier legerement d'un moteur de production a l'autre.

011 TG.indd, b

Intermittierende Werte maximal 10% von jeder Betriebsminute.
 Capacidad de funcionamiento intermitente valida para 10% por cada minuto.
 Leistungsdaten sind gemessen mit SAE 10W40 bei einer Viskositat von 43,1 Cst bei 54°C. Geringfuegige Abweichungen von den Katalogdaten sind moeglich.

Datos tecnicos obtenidos con aceite 10W40 de 200 SUS de viscosidad a 54°C (130°F). Los datos proporcionados son valores tipcos. Los valores exactos reales podrian tener una pequena variacion entre distintos motores.



WARNING
 This product can expose you to chemicals including lead and DEHP, which are known to the State of California to cause cancer, and birth defects or other reproductive harm. For more information go to www.p65warnings.ca.gov

Parker Hannifin Corporation
 Pump & Motor Division
 Greeneville, Tennessee, USA

TG 0475

29.1 cu in / rev

	PRESSURE (PSID)					
	500	1000	1500	2000	2500	3000
.5	1768 3	3732 3	5733 2	7744 1	9762 1	
1	1868 7	3878 7	5879 6	7851 5	9838 4	11830 3
2	1964 15	4055 14	6180 14	8237 12	10241 10	12136 8
3	1972 23	4074 22	6208 21	8321 19	10379 17	12355 13
4	2005 31	4135 30	6287 29	8382 27	10463 24	12496 20
5	2004 39	4129 38	6304 37	8428 34	10514 31	12544 26
7	1990 55	4133 54	6308 52	8445 50	10555 45	12602 40
9	1924 70	4104 69	6285 68	8430 65	10528 60	12608 54
12	1775 94	3974 93	6157 91	8328 87	10446 82	12528 75
15	1619 118	3784 116	5990 114	8188 110	10311 104	12372 96
20	1314 157	3373 156	5629 153	7853 149	10038 141	12145 132
25	1141 197	3029 196	5220 193	7427 189	9629 182	11757 174
30	606 237	2505 236	4649 233	6766 230	8878 224	10989 219

Flow (GPM)

TORQUE (LB IN) 6766
SPEED (RPM) 230

Cont. Int.

Intermittent operation rating applies to 10% of every minute.
 Fonctionnement interm. 10% max. de chaque minute d'utilisation.
 Performance data based on testing using 10W40 oil with a viscosity of 200 SUS at 54° C (130° F). Performance data is typical. Actual data may vary slightly from one production motor to another.
 Les donnees sur les performances sont basees sur des tests utilisant de l'huile 10W40 d'une viscosite de 200 SUS a 54°C (130°F). Ces donnees correspondent a des situations typiques. Les donnees reelles peuvent varier legerement d'un moteur de production a l'autre.

Intermittierende Werte maximal 10% von jeder Betriebsminute.
 Capacidad de funcionamiento intermitente valida para 10% por cada minuto.
 Leistungsdaten sind gemessen mit SAE 10W40 bei einer Viskositat von 43,1 Cst bei 54°C. Geringfuegige Abweichungen von den Katalogdaten sind moeglich.
 Datos tecnicos obtenidos con aceite 10W40 de 200 SUS de viscosidad a 54°C (130°F). Los datos proporcionados son valores tipcos. Los valores exactos reales podrian tener una pequena variacion entre distintos motores.

011 TG.indd, b



WARNING
 This product can expose you to chemicals including lead and DEHP, which are known to the State of California to cause cancer, and birth defects or other reproductive harm. For more information go to www.p65warnings.ca.gov

Parker Hannifin Corporation
 Pump & Motor Division
 Greeneville, Tennessee, USA

TG 0530

32.2 cu in / rev

	PRESSURE (PSID)				
	500	1000	1500	2000	2500
.5	2080 3	4256 3	6479 2	8726 2	11012 1
1	2158 7	4372 6	6592 6	8779 5	10994 4
2	2246 14	4567 13	6869 12	9126 11	11376 9
3	2242 21	4578 20	6916 19	9237 17	11500 14
4	2253 28	4625 27	6977 25	9296 23	11586 20
5	2235 35	4629 34	7002 32	9333 29	11626 26
7	2182 49	4599 48	7006 46	9362 42	11659 38
9	2095 63	4535 62	6960 59	9330 55	11650 50
12	1943 85	4390 83	6825 80	9217 75	11549 69
15	1753 106	4199 104	6638 100	9052 95	11408 87
20	1327 141	3783 139	6262 135	8701 129	11086 120
25	1011 177	3300 175	5751 171	8210 165	10639 158
30	269 213	2698 211	5083 208	7415 203	9814 197

Flow (GPM)

TORQUE (LB IN) 9814
SPEED (RPM) 197

Cont. Int.

Intermittent operation rating applies to 10% of every minute.

Fonctionnement interm. 10% max. de chaque minute d'utilisation.

Performance data based on testing using 10W40 oil with a viscosity of 200 SUS at 54° C (130° F). Performance data is typical. Actual data may vary slightly from one production motor to another.

Les donnees sur les performances sont basees sur des tests utilisant de l'huile 10W40 d'une viscosite de 200 SUS a 54°C (130°F). Ces donnees correspondent a des situations typiques. Les donnees reelles peuvent varier legerement d'un moteur de production a l'autre.

011 TG.indd, b

Intermittierende Werte maximal 10% von jeder Betriebsminute.

Capacidad de funcionamiento intermitente valida para 10% por cada minuto. Leistungsdaten sind gemessen mit SAE 10W40 bei einer Viskositat von 43,1 Cst bei 54°C. Geringfuegige Abweichungen von den Katalogdaten sind moeglich.

Datos tecnicos obtenidos con aceite 10W40 de 200 SUS de viscosidad a 54°C (130°F). Los datos proporcionados son valores tipcos. Los valores exactos reales podrian tener una pequena variacion entre distintos motores.



WARNING
This product can expose you to chemicals including lead and DEHP, which are known to the State of California to cause cancer, and birth defects or other reproductive harm. For more information go to www.p65warnings.ca.gov

Parker Hannifin Corporation
Pump & Motor Division
Greeneville, Tennessee, USA

TG 0625

38.0 cu in / rev

	PRESSURE (PSID)				
	500	1000	1500	1750	2250
.5	1939 2	4593 1			
1	2087 5	4665 3	7283 2	8680 2	11579 1
2	2338 11	4991 9	7590 8	8853 7	11458 5
3	2386 17	5101 15	7753 13	9055 12	11689 9
4	2457 23	5202 21	7872 19	9174 17	11769 14
5	2479 29	5246 27	7943 25	9242 23	11821 18
7	2464 41	5273 39	7995 36	9306 34	11859 28
9	2401 53	5223 51	7993 48	9337 45	11935 39
12	2254 71	5092 69	7886 65	9239 62	11900 54
15	2052 89	4901 87	7721 83	9086 80	11763 70
20	1600 120	4490 117	7334 112	8725 109	11424 98
25	1063 151	3933 148	6818 144	8235 140	11021 131
30	359 182	3250 180	6074 176	7443 172	10179 165

Flow (GPM)

TORQUE (LB IN) 7443
SPEED (RPM) 172

Cont. Int.

Intermittent operation rating applies to 10% of every minute.
Fonctionnement interm. 10% max. de chaque minute d'utilisation.
Performance data based on testing using 10W40 oil with a viscosity of 200 SUS at 54° C (130° F). Performance data is typical. Actual data may vary slightly from one production motor to another.
Les donnees sur les performances sont basees sur des tests utilisant de l'huile 10W40 d'une viscosite de 200 SUS a 54°C (130°F). Ces donnees correspondent a des situations typiques. Les donnees reelles peuvent varier legerement d'un moteur de production a l'autre.

Intermittierende Werte maximal 10% von jeder Betriebsminute.
Capacidad de funcionamiento intermitente valida para 10% por cada minuto.
Leistungsdaten sind gemessen mit SAE 10W40 bei einer Viskositat von 43,1 Cst bei 54°C. Geringfuegige Abweichungen von den Katalogdaten sind moeglich.
Datos tecnicos obtenidos con aceite 10W40 de 200 SUS de viscosidad a 54°C (130°F). Los datos proporcionados son valores tipcos. Los valores exactos reales podrian tener una pequena variacion entre distintos motores.

011 TG.indd, b



WARNING
This product can expose you to chemicals including lead and DEHP, which are known to the State of California to cause cancer, and birth defects or other reproductive harm. For more information go to www.p65warnings.ca.gov

Parker Hannifin Corporation
Pump & Motor Division
Greeneville, Tennessee, USA

TG 0785

48.0 cu in / rev

	PRESSURE (PSID)			
	500	1000	1500	2000
.5	2910 2	6153 2	9607 1	12950 1
1	3011 4	6296 4	9670 3	12919 3
2	3217 9	6536 8	9935 7	13060 6
3	3220 14	6613 13	9977 11	13079 9
4	3265 19	6679 17	10021 15	13078 13
5	3263 23	6703 22	10047 19	13103 16
7	3218 33	6722 31	10068 28	13062 24
9	3107 43	6664 41	10108 36	13185 31
12	2892 57	6489 55	9959 49	13082 42
15	2643 71	6238 69	9733 62	12938 54
20	2044 95	5673 92	9239 85	12636 75
25	2313 119	4976 117	8571 110	12073 101
30	496 143	4104 141	7582 137	11024 130

Flow (GPM)

TORQUE (LB IN) 11024
SPEED (RPM) 130

TG 0960

58.5 cu in / rev

	PRESSURE (PSID)		
	500	1000	1500
.5	3692 2	7712 1	11750 1
1	3788 3	7858 3	11895 3
2	3900 7	8045 7	12058 6
3	3905 11	8078 11	12135 10
4	3939 15	8155 14	12210 13
5	3923 19	8173 18	12238 17
7	3860 27	8160 26	12262 24
9	3733 35	8074 34	12224 31
12	3475 47	7848 45	12062 42
15	3149 58	7545 57	11823 53
20	2437 78	6843 76	11227 72
25	2969 98	5990 96	10360 92
30	603 118	4919 117	9170 113

Flow (GPM)

TORQUE (LB IN) 9170
SPEED (RPM) 113

Cont. Int.

Intermittent operation rating applies to 10% of every minute.

Fonctionnement interm. 10% max. de chaque minute d'utilisation.

Performance data based on testing using 10W40 oil with a viscosity of 200 SUS at 54° C (130° F). Performance data is typical. Actual data may vary slightly from one production motor to another.

Les donnees sur les performances sont basees sur des tests utilisant de l'huile 10W40 d'une viscosite de 200 SUS a 54°C (130°F). Ces donnees correspondent a des situations typiques. Les donnees reelles peuvent varier legerement d'un moteur de production a l'autre.

011 TG.indd, b

Intermittierende Werte maximal 10% von jeder Betriebsminute.

Capacidad de funcionamiento intermitente valida para 10% por cada minuto.

Leistungsdaten sind gemessen mit SAE 10W40 bei einer Viskosität von 43,1 Cst bei 54°C. Geringfügige Abweichungen von den Katalogdaten sind möglich.

Datos tecnicos obtenidos con aceite 10W40 de 200 SUS de viscosidad a 54°C (130°F). Los datos proporcionados son valores tipicos. Los valores exactos reales podrian tener una pequena variacion entre distintos motores.



WARNING
This product can expose you to chemicals including lead and DEHP, which are known to the State of California to cause cancer, and birth defects or other reproductive harm. For more information go to www.p65warnings.ca.gov

Parker Hannifin Corporation
Pump & Motor Division
Greeneville, Tennessee, USA

Flange Mount / Standardgehäuse
Monture à bride(s) / Montaje de brida

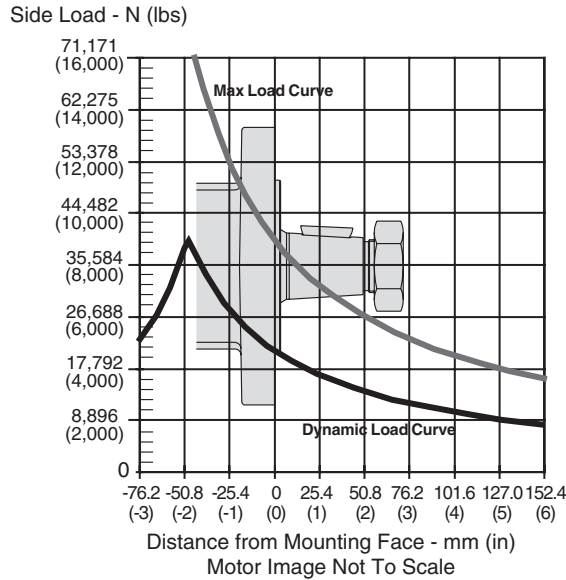

The dynamic side load curve is based on uni-directional steady state loads for L_{10} bearing life at 3×10^6 revolutions. Die zulässige auslegbare radiale Wellenbelastungskurve ist unter ruhenden, einseitig statisch gerichteten Lastverhältnissen auf eine L_{10} Lebensdauer mit 3×10^6 Umdrehungen kalkuliert. La courbe de charge latérale permise se base sur des charges unidirectionnelles en régime permanent pour le roulement L_{10} à 3×10^6 révolutions. La curva de valores admisibles de carga lateral está basada en cargas constantes para cojinetes L_{10} a 3×10^6 revoluciones.

Wheel Mount / Radnabengehäuse
Monture à roue/ Montaje de rueda

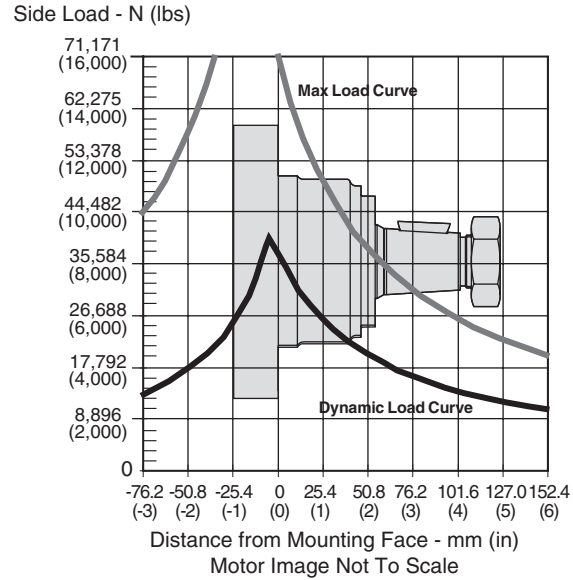

The maximum load curve is defined by bearing static load capacity. This curve should not be exceeded at any time including shock loads. Die maximale radiale Wellenbelastungskurve ist definiert als maximale statische Last ohne Drehzahl. Sie gilt als Grenze und sollte keinesfalls überschritten werden. La courbe de charge maximale est définie par la capacité de charge statique portante. Cette courbe ne devrait être dépassée en aucun moment y compris pour les charges par à-coups. La curva de carga máxima queda definida por la capacidad de carga estática del cojinete. No se deben superar los valores de esta curva, ni siquiera con cargas provisorias de impacto.

Equation to Calculate the Expected Radial Bearing Life
Gleichung zur Ermittlung der Lagerlebensdauer

Equation to calculate the dynamic bearing life for a given load:
 Bestimmung der erlaubten radialen Wellenbelastung mit vorgegebener Last

Use F_a , F_b and S in equation to determine hours of L_{10} bearing life.
 Die Lebensdauer in Stunden ergibt sich durch einsetzen von F_a , F_b , und S in die nachstehende Formel.

$$L = \frac{3 \times 10^6}{60 \times S} \left\{ \frac{F_a}{F_b} \right\}^{3.33}$$

Where / Mit:

- S = Shaft Speed RPM / Abtriebswellendrehzahl in min^{-1}
- L = Life In Hours / Lebensdauer in Stunden
- F_a = Dynamic side load defined by above curve at a distance from mounting flange. / Erlaubte radiale Wellenbelastung als Function der Laenge
- F_b = Application side load. / Anwendungsseitige Wellenbelastung

Note: Calculations are based on L_{10} bearing life per ISO 281.
 Auslegung basiert auf einer L_{10} Lebensdauer nach ISO 281.

Code: AM

SAE A 2-Bolt, 5/16-18 UNC Manifold

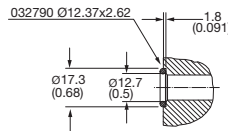

Motor with manifold mount is supplied with 2 o-rings.
 Zum Motor mit Universalanschluß werden 2 o-ringe geliefert.
 Deux joints toriques sont livrés avec les moteurs a plan de raccordement universel.
 Il blocchetto connessioni é corredato da 2 OR.

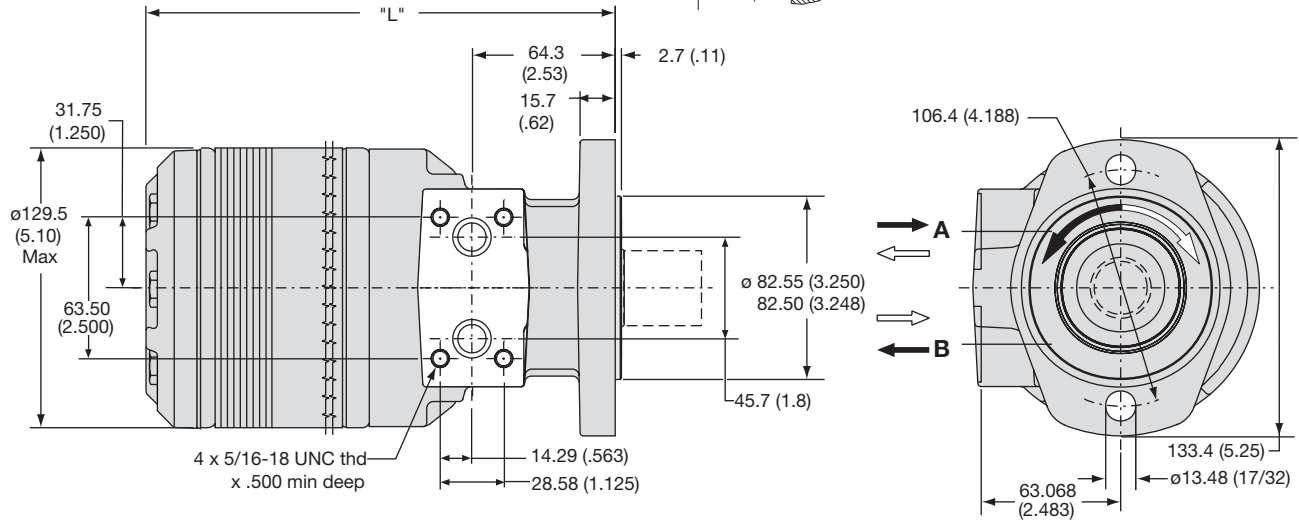

Code AM	disp.	0140	0170	0195	0240	0280	0310	0335	0405	0475	0530	0625	0785	0960
Weight/Gewicht	kg	14.2	14.5	14.7	15.1	15.5	15.7	15.9	16.5	17.2	17.9	18.6	20.2	21.9
Poids/Peso	(lb)	(31.4)	(32.0)	(32.5)	(33.3)	(34.2)	(34.7)	(35.1)	(36.4)	(37.9)	(39.5)	(41.1)	(44.5)	(48.3)
Length	"L" mm	195.6	198.6	201.4	206.5	211.3	214.8	217.7	225.0	233.7	240.0	249.4	268.4	287.5
	"L" (in)	(7.70)	(7.82)	(7.95)	(8.13)	(8.32)	(8.46)	(8.57)	(8.86)	(9.20)	(9.45)	(9.82)	(10.57)	(11.32)

Code: AS

SAE A 2-Bolt, 7/8-14 SAE

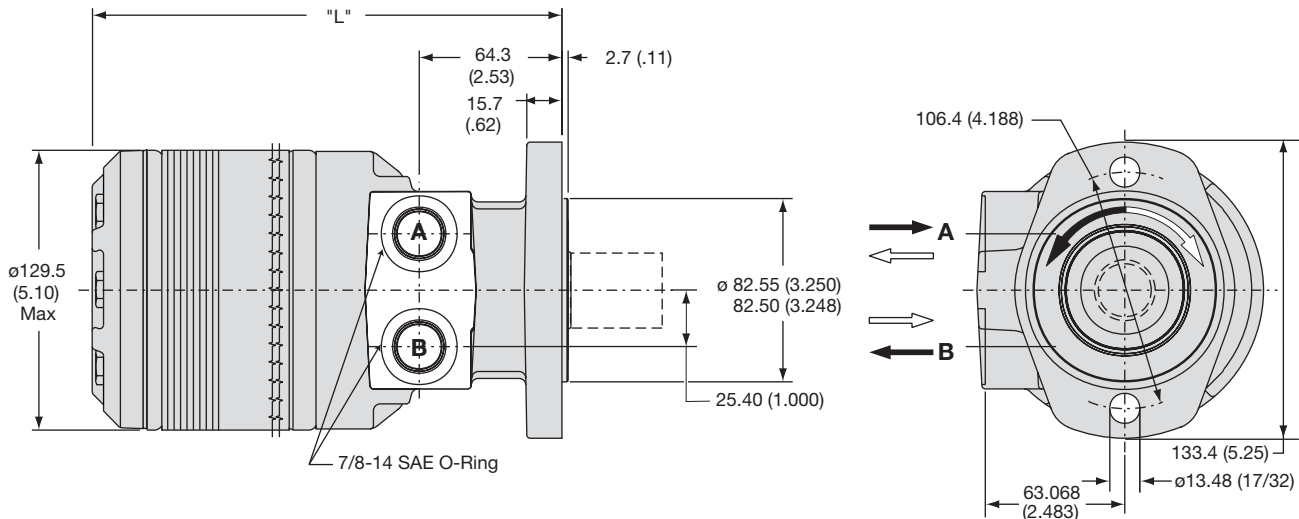

Code AS	disp.	0140	0170	0195	0240	0280	0310	0335	0405	0475	0530	0625	0785	0960
Weight/Gewicht	kg	14.2	14.5	14.7	15.1	15.5	15.7	15.9	16.5	17.2	17.9	18.6	20.2	21.9
Poids/Peso	(lb)	(31.4)	(32.0)	(32.5)	(33.3)	(34.2)	(34.7)	(35.1)	(36.4)	(37.9)	(39.5)	(41.1)	(44.5)	(48.3)
Length	"L" mm	195.6	198.6	201.4	206.5	211.3	214.8	217.7	225.0	233.7	240.0	249.4	268.4	287.5
	"L" (in)	(7.70)	(7.82)	(7.95)	(8.13)	(8.32)	(8.46)	(8.57)	(8.86)	(9.20)	(9.45)	(9.82)	(10.57)	(11.32)

English equivalents for metric specifications are shown in ().

011 TG.indd, b



WARNING
 This product can expose you to chemicals including lead and DEHP, which are known to the State of California to cause cancer, and birth defects or other reproductive harm. For more information go to www.p65warnings.ca.gov

Parker Hannifin Corporation
 Pump & Motor Division
 Greeneville, Tennessee, USA

Code: LS

Wheel, Front Brake Nose, 7/8-14 SAE

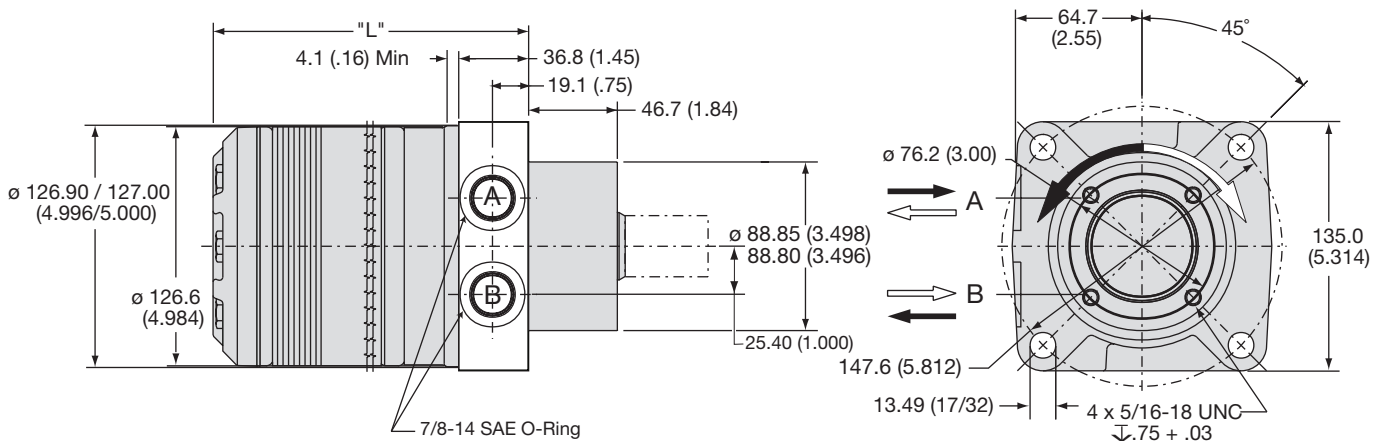

Code LS	disp.	0140	0170	0195	0240	0280	0310	0335	0405	0475	0530	0625	0785	0960
Weight/Gewicht	kg	14.6	14.8	15.1	15.5	15.9	16.1	16.3	16.9	17.5	18.3	19.0	20.5	22.2
Poids/Peso	(lb)	(32.2)	(37.7)	(33.3)	(34.1)	(35.0)	(35.5)	(35.8)	(37.2)	(38.6)	(40.3)	(41.8)	(45.3)	(49.0)
Length	"L" mm	150.3	153.4	156.7	161.3	168.1	169.7	172.5	179.8	188.5	194.8	204.2	233.3	242.3
	"L" (in)	(5.92)	(6.04)	(6.17)	(6.35)	(6.54)	(6.68)	(6.79)	(7.08)	(7.42)	(7.67)	(8.04)	(8.79)	(9.54)

Code: MS

Magneto, 7/8-14 SAE

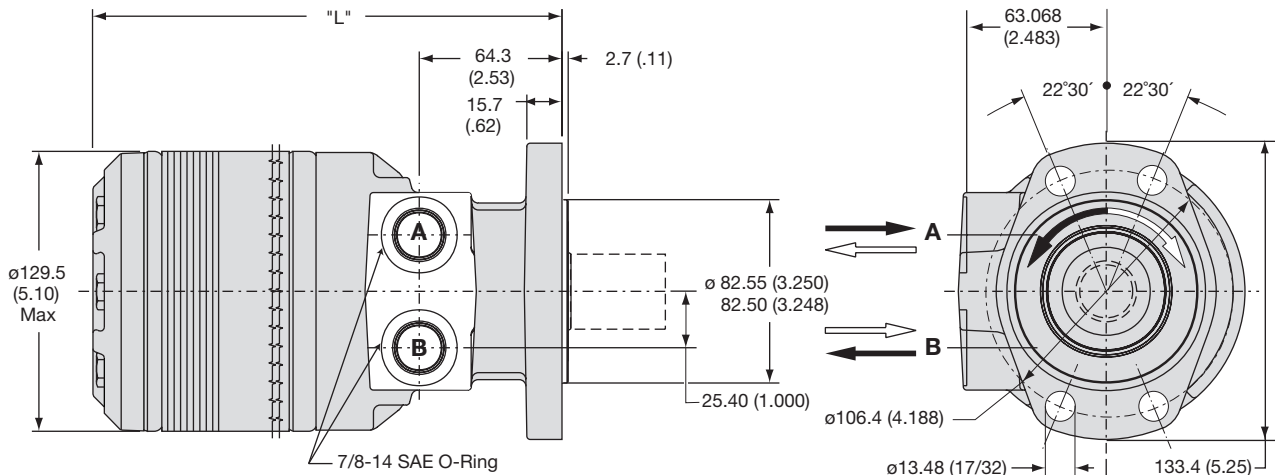

Code MS	disp.	0140	0170	0195	0240	0280	0310	0335	0405	0475	0530	0625	0785	0960
Weight/Gewicht	kg	14.2	14.5	14.7	15.1	15.5	16.1	15.9	16.5	17.2	17.9	18.6	20.2	21.9
Poids/Peso	(lb)	(31.4)	(32.0)	(32.5)	(33.3)	(34.2)	(35.5)	(35.1)	(36.4)	(37.9)	(39.5)	(41.1)	(44.5)	(48.3)
Length	"L" mm	195.6	198.6	201.4	206.5	211.3	214.8	217.7	225.0	233.7	240.0	249.4	268.4	287.5
	"L" (in)	(7.70)	(7.82)	(7.95)	(8.13)	(8.32)	(8.46)	(8.57)	(8.86)	(9.20)	(9.45)	(9.82)	(10.57)	(11.32)

English equivalents for metric specifications are shown in ().

011 TG.indd, b



WARNING
 This product can expose you to chemicals including lead and DEHP, which are known to the State of California to cause cancer, and birth defects or other reproductive harm. For more information go to www.p65warnings.ca.gov

Parker Hannifin Corporation
 Pump & Motor Division
 Greeneville, Tennessee, USA

Code: BS

SAE B 2-Bolt, 7/8-14 SAE O-Ring

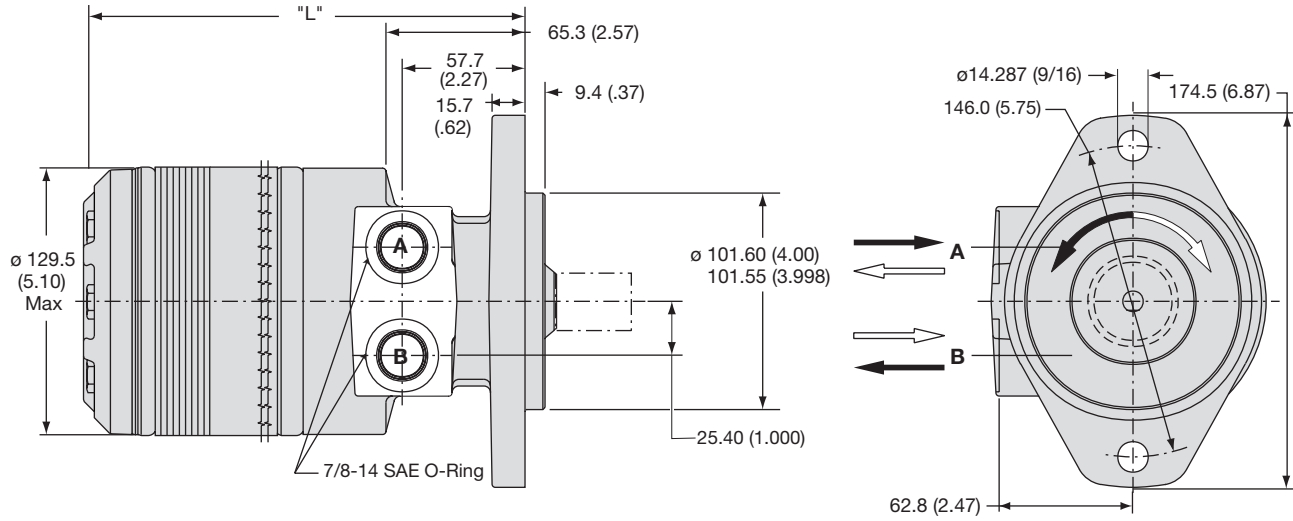

Code BS	disp.	0140	0170	0195	0240	0280	0310	0335	0405	0475	0530	0625	0785	0960
Weight/Gewicht	kg	14.9	15.2	15.3	15.7	16.1	16.4	16.6	17.1	17.8	18.6	19.3	20.8	22.5
Poids/Peso	(lb)	(32.8)	(33.4)	(33.9)	(34.7)	(35.6)	(36.1)	(36.5)	(37.8)	(39.3)	(40.9)	(42.5)	(45.9)	(49.7)
Length	"L" mm	195.6	198.6	201.4	206.5	211.3	214.8	217.7	225.0	233.7	240.0	249.4	268.4	287.5
	"L" (in)	(7.70)	(7.82)	(7.95)	(8.13)	(8.32)	(8.46)	(8.57)	(8.86)	(9.20)	(9.45)	(9.82)	(10.57)	(11.32)

Code: US

Wheel, Standard, 7/8-14 SAE

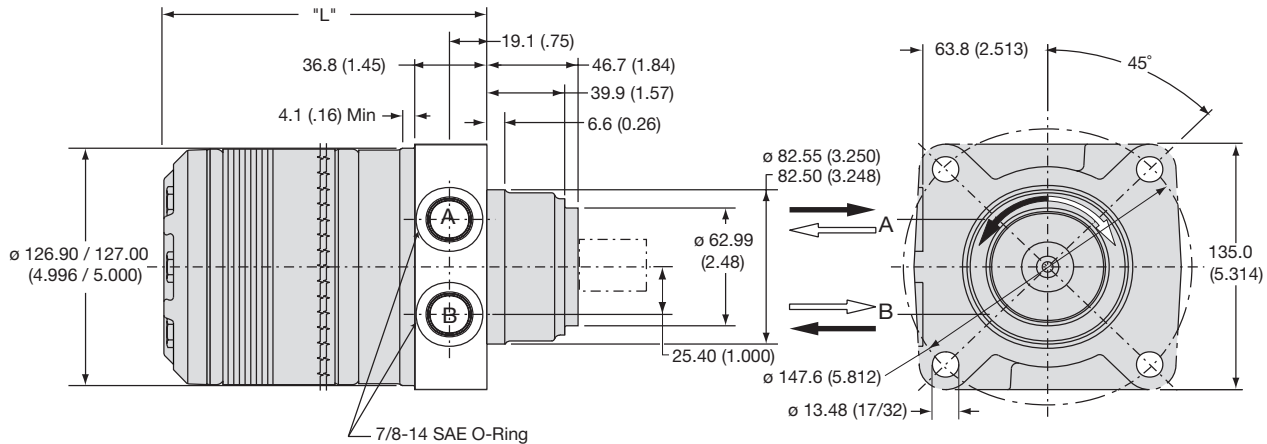

Code US	disp.	0140	0170	0195	0240	0280	0310	0335	0405	0475	0530	0625	0785	0960
Weight/Gewicht	kg	14.6	14.8	15.1	15.5	15.9	16.1	16.3	16.9	17.51	18.3	19.0	20.5	22.2
Poids/Peso	(lb)	(32.2)	(32.7)	(33.3)	(34.1)	(35.0)	(35.5)	(35.8)	(37.2)	(38.6)	(40.3)	(41.8)	(45.3)	(49.0)
Length	"L" mm	150.3	153.4	156.7	161.3	168.1	169.7	172.5	179.8	188.5	194.8	204.2	233.3	242.3
	"L" (in)	(5.92)	(6.04)	(6.17)	(6.35)	(6.54)	(6.68)	(6.79)	(7.08)	(7.42)	(7.67)	(8.04)	(8.79)	(9.54)

English equivalents for metric specifications are shown in ().

011 TG.indd, b



WARNING
 This product can expose you to chemicals including lead and DEHP, which are known to the State of California to cause cancer, and birth defects or other reproductive harm. For more information go to www.p65warnings.ca.gov

Parker Hannifin Corporation
 Pump & Motor Division
 Greeneville, Tennessee, USA

Code: WE

Wheel, Optional, Manifold Rear Port

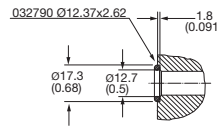

Motor with manifold mount is supplied with 2 o-rings.
 Zum Motor mit Universalanschluß werden 2 o-ringe geliefert.
 Deux joints toriques sont livrés avec les moteurs a plan de raccordement universel.
 Il bloccetto connessioni è corredato da 2 OR.

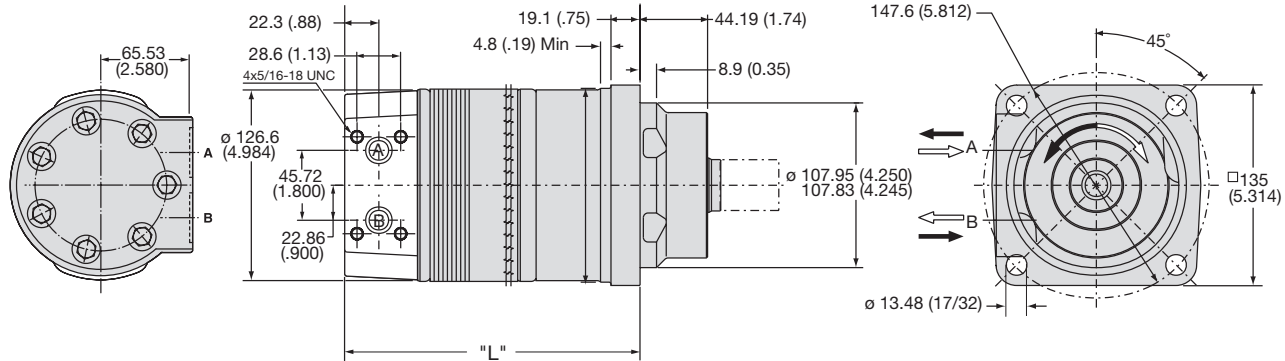

Code WE	disp.	0140	0170	0195	0240	0280	0310	0335	0405	0475	0530	0625	0785	0960
Weight/Gewicht	kg	17.6	17.8	18.1	18.4	18.8	19.1	19.3	19.8	20.5	21.3	22.0	23.5	25.2
Poids/Peso	(lb)	(38.7)	(39.3)	(39.8)	(40.6)	(41.5)	(42.0)	(42.4)	(43.7)	(45.2)	(46.8)	(48.4)	(51.8)	(55.6)
Length	"L" mm	177.5	180.6	183.9	188.7	193.3	196.9	199.6	207.0	215.6	222.0	231.6	250.7	269.7
	"L" (in)	(6.99)	(7.11)	(7.24)	(7.43)	(7.61)	(7.75)	(7.86)	(8.15)	(8.49)	(8.74)	(9.12)	(9.87)	(10.62)

Code: VB

SAE A 4-Bolt, 7/8-14 SAE Rear Port

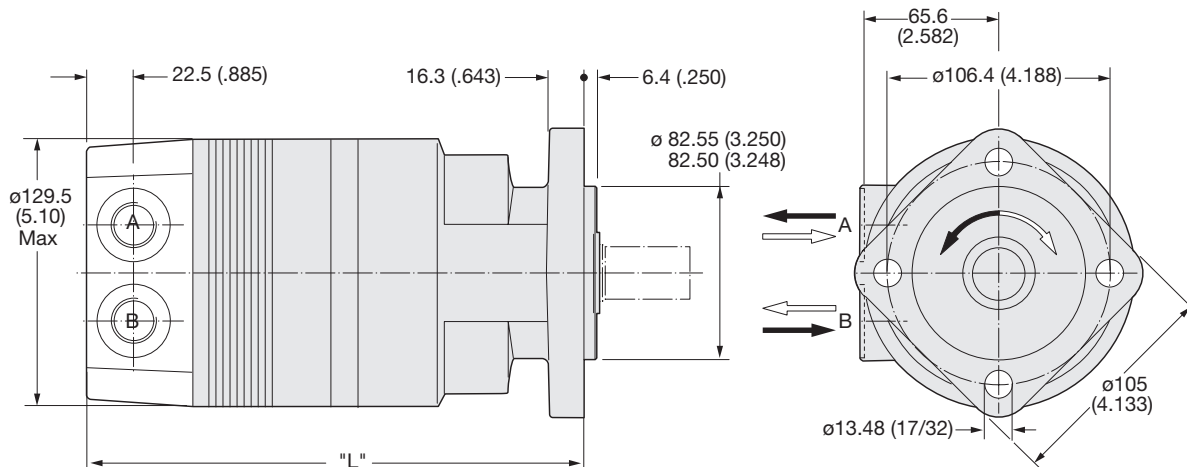

Code VB	disp.	0140	0170	0195	0240	0280	0310	0335	0405	0475	0530	0625	0785	0960
Weight/Gewicht	kg	16.1	16.3	16.6	17.0	17.4	17.6	17.8	18.4	19.0	19.8	20.5	22.0	23.7
Poids/Peso	(lb)	(35.5)	(35.9)	(36.6)	(37.5)	(38.4)	(38.8)	(39.2)	(41.0)	(41.9)	(43.7)	(45.2)	(48.5)	(52.2)
Length	"L" mm	216.7	219.7	223.0	227.8	232.4	236.0	238.8	246.1	254.8	261.1	270.8	289.8	308.9
	"L" (in)	(8.53)	(8.65)	(8.78)	(8.97)	(9.15)	(9.29)	(9.40)	(9.69)	(10.03)	(10.28)	(10.66)	(11.41)	(12.16)

English equivalents for metric specifications are shown in ().

011 TG.indd, b



WARNING
 This product can expose you to chemicals including lead and DEHP, which are known to the State of California to cause cancer, and birth defects or other reproductive harm. For more information go to www.p65warnings.ca.gov

Parker Hannifin Corporation
 Pump & Motor Division
 Greeneville, Tennessee, USA

Code: DB

Large Wheel Mount, 7/8-14 SAE Rear Port

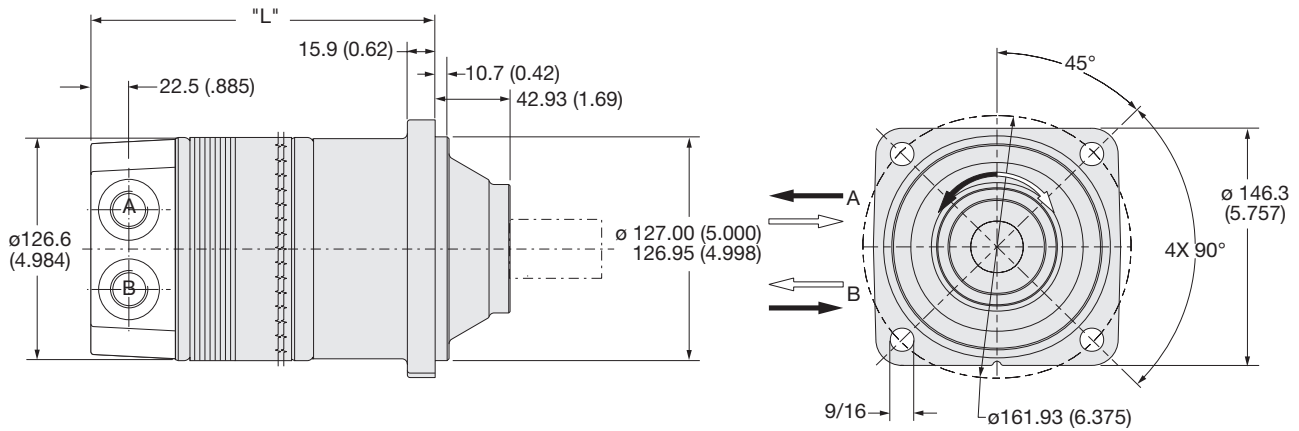

Code DB	disp.	0140	0170	0195	0240	0280	0310	0335	0405	0475	0530	0625	0785	0960
Weight/Gewicht	kg	17.6	17.8	18.1	18.4	18.8	19.1	19.3	19.8	20.5	21.3	22.0	23.5	25.2
Poids/Peso	(lb)	(38.7)	(39.3)	(39.8)	(40.6)	(41.5)	(42.0)	(42.4)	(43.7)	(45.2)	(46.8)	(48.4)	(51.8)	(55.6)
Length	"L" mm	178.8	182.1	185.2	190.0	194.8	198.4	201.2	208.5	216.9	223.3	232.9	252.0	271.0
	"L" (in)	(7.04)	(7.17)	(7.29)	(7.48)	(7.67)	(7.81)	(7.92)	(8.21)	(8.54)	(8.79)	(9.17)	(9.92)	(10.67)

Code: ES

Modified SAE A 6-Bolt, 7/8-14 SAE O-Ring

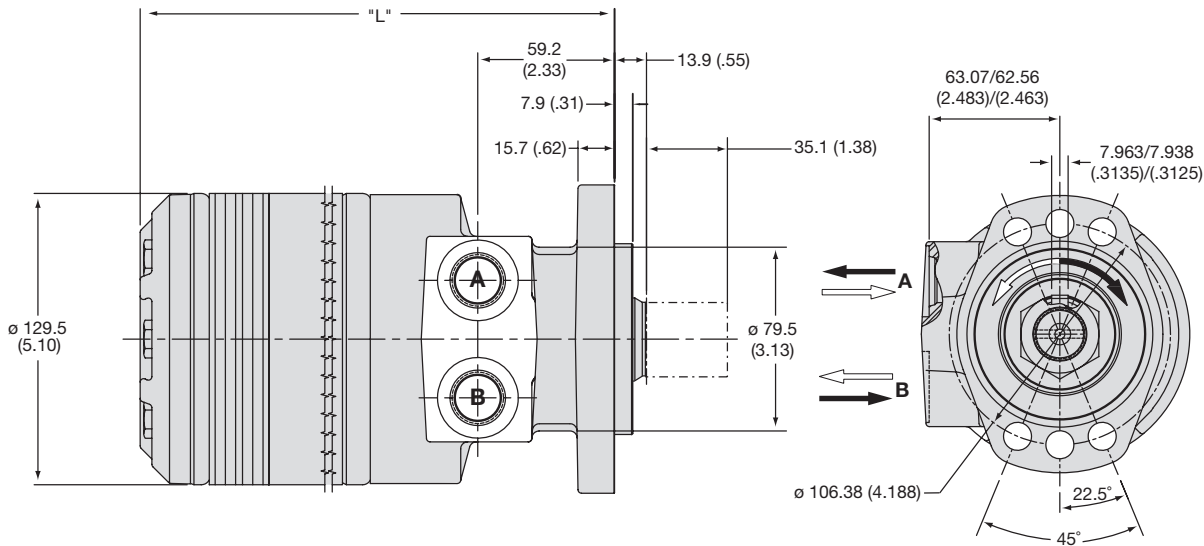

Code ES	disp.	0140	0170	0195	0240	0280	0310	0335	0360	0405	0475	0530	0625	0785	0960
Weight/Gewicht	kg	14.2	14.5	14.7	15.1	15.5	16.1	16.3	16.4	16.5	17.2	17.9	18.6	20.2	21.9
Poids/Peso	(lb)	(31.4)	(32.0)	(33.3)	(33.3)	(34.2)	(35.5)	(35.9)	(36.2)	(36.4)	(37.9)	(39.5)	(41.1)	(44.5)	(48.3)
Length	"L" mm	189.5	192.5	195.8	200.4	205.2	208.5	211.6	214.9	218.9	227.6	233.9	243.3	262.4	281.4
	"L" (in)	(7.46)	(7.58)	(7.71)	(7.89)	(8.08)	(8.21)	(8.33)	(8.46)	(8.62)	(8.96)	(9.21)	(9.58)	(10.33)	(11.08)

English equivalents for metric specifications are shown in ().

011 TG.indd, b



WARNING

This product can expose you to chemicals including lead and DEHP, which are known to the State of California to cause cancer, and birth defects or other reproductive harm. For more information go to www.p65warnings.ca.gov

Parker Hannifin Corporation
 Pump & Motor Division
 Greeneville, Tennessee, USA

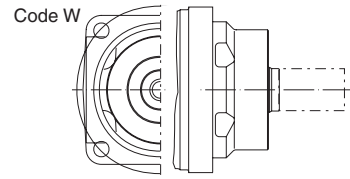
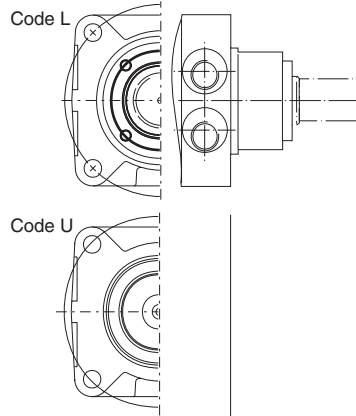
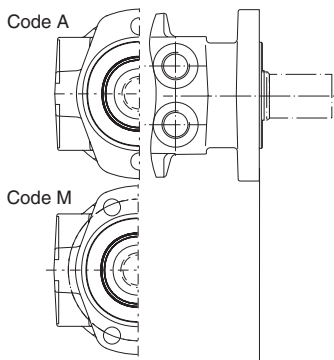

Code: 01

1" 6B Spline

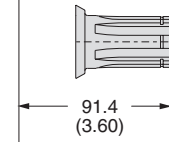
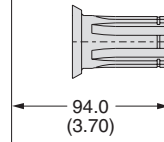
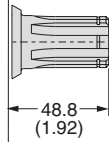

Code: 03

1 1/4" Keyed

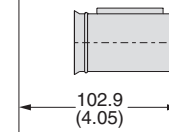
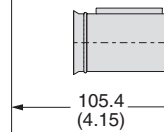
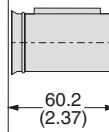

Code: 05

1" 1/4 14 Tooth Spline

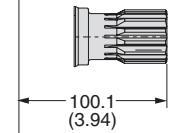
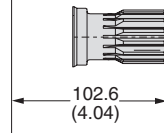
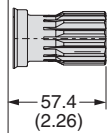

Code: 06

19 Tooth Spline

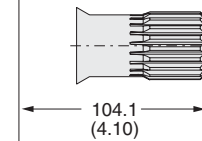
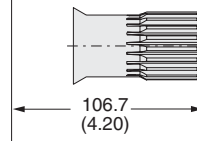
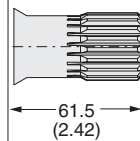

Code: 46

32 mm Keyed

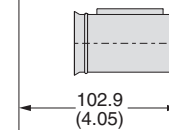
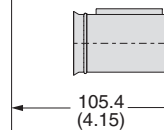
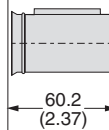

Code: 62

1" 1/4 14 Tooth Spline SAE

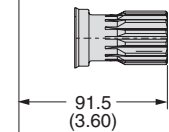
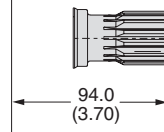
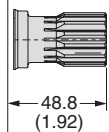

English equivalents for metric specifications are shown in ().

011 TG.indd, b



WARNING
 This product can expose you to chemicals including lead and DEHP, which are known to the State of California to cause cancer, and birth defects or other reproductive harm. For more information go to www.p65warnings.ca.gov

Parker Hannifin Corporation
 Pump & Motor Division
 Greeneville, Tennessee, USA

Code: 01

1" 6B Spline

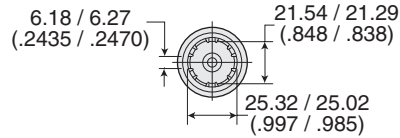
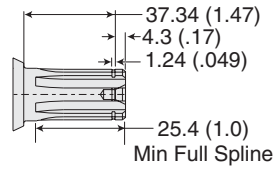

Code: 03

1 1/4" Keyed

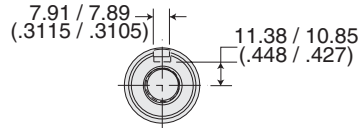
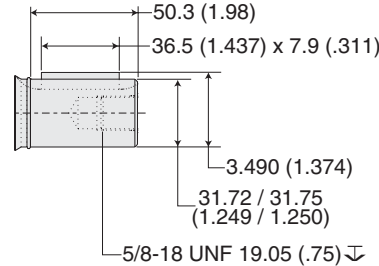

Code: 05

1" 1/4 14 Tooth Spline

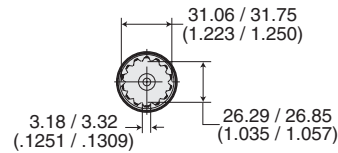
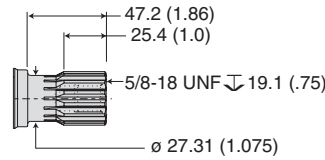

Code: 06

19 Tooth Spline

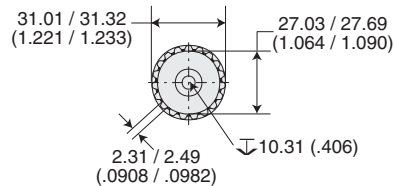
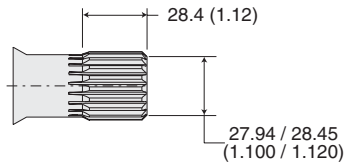

Code: 46

32 mm Keyed

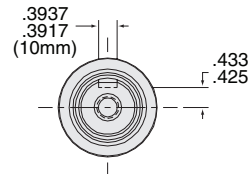
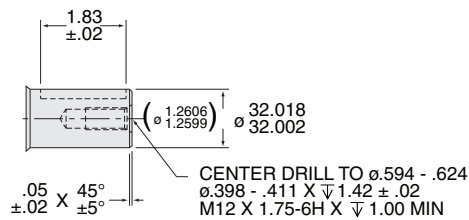

Code: 62

1" 1/4 14 Tooth Spline SAE

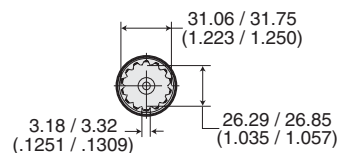
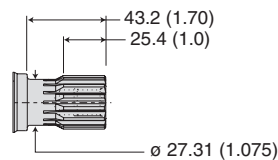

English equivalents for metric specifications are shown in ().

011 TG.indd, b



WARNING

This product can expose you to chemicals including lead and DEHP, which are known to the State of California to cause cancer, and birth defects or other reproductive harm. For more information go to www.p65warnings.ca.gov

Parker Hannifin Corporation
Pump & Motor Division
Greenville, Tennessee, USA

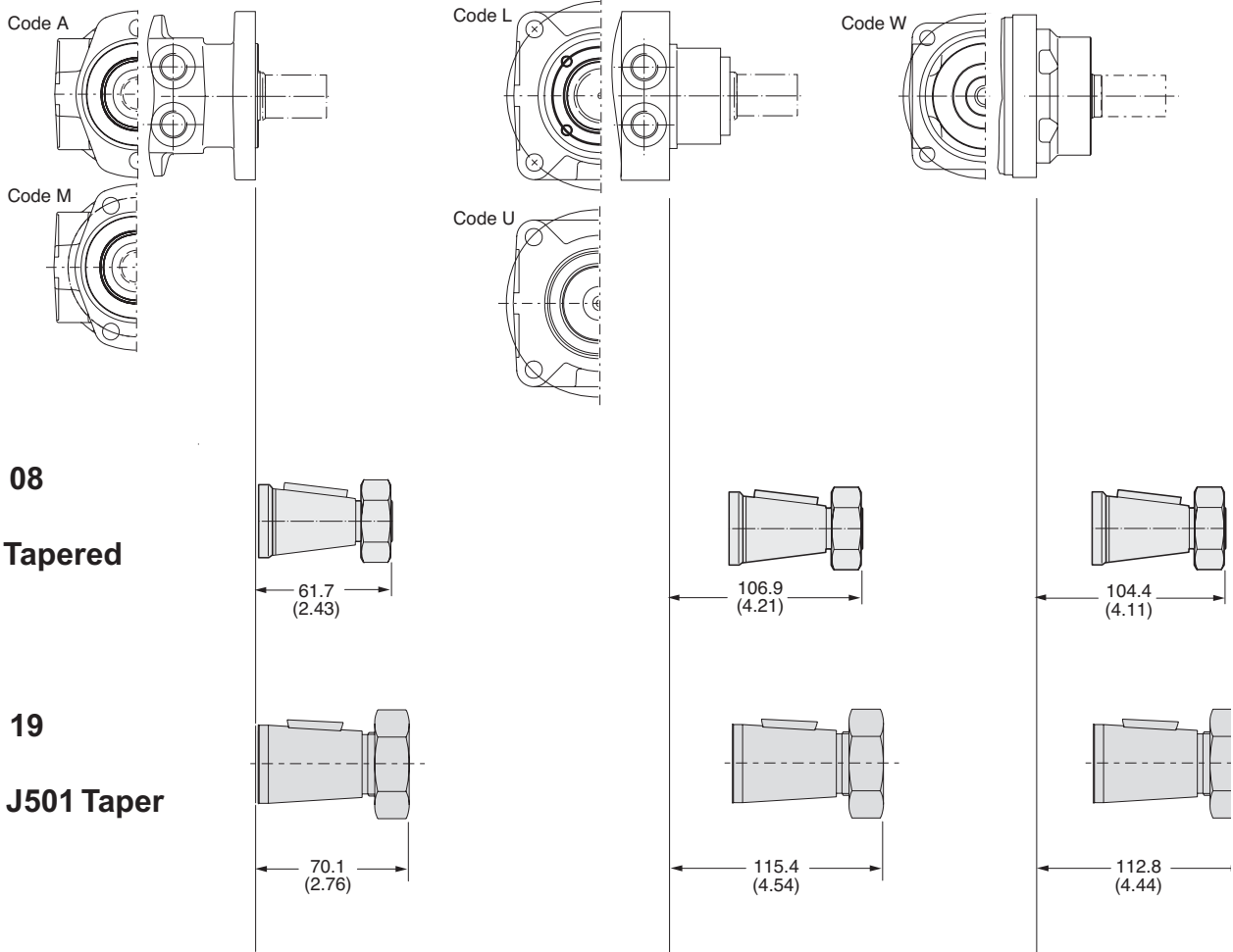

Code: 08
1 1/4" Tapered

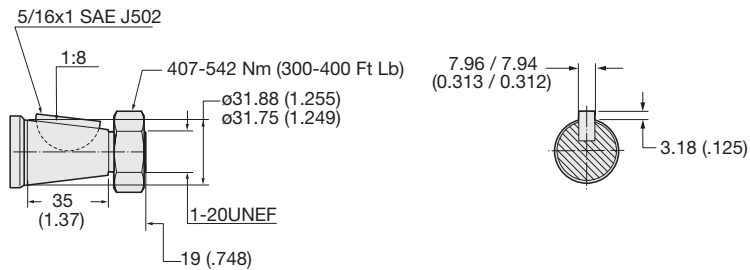

Code: 19
1 3/8" J501 Taper

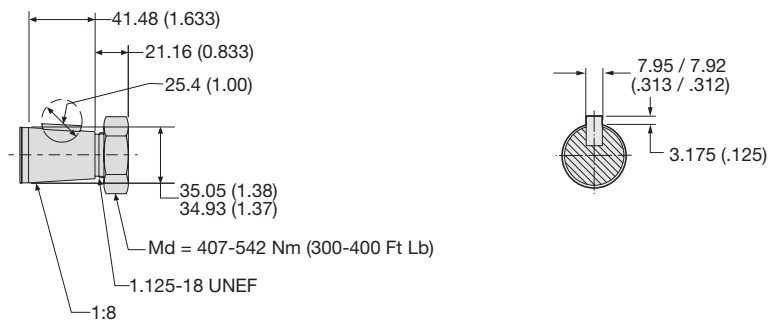

English equivalents for metric specifications are shown in ().

011 TG.indd, b



WARNING
This product can expose you to chemicals including lead and DEHP, which are known to the State of California to cause cancer, and birth defects or other reproductive harm. For more information go to www.p65warnings.ca.gov