

# Mirage WU-L

**User Manual**

020-100774-01

**CHRISTIE®**



# Mirage WU-L

**User Manual**

020-100774-01

## NOTICES

### COPYRIGHT AND TRADEMARKS

© 2011-2012 Christie Digital Systems USA, Inc. All rights reserved.

All brand names and product names are trademarks, registered trademarks or trade names of their respective holders.

### REGULATORY

The product has been tested and found to comply with the limits for a Class A digital device, pursuant to Part 15 of the FCC Rules. These limits are designed to provide reasonable protection against harmful interference when the product is operated in a commercial environment. The product generates, uses, and can radiate radio frequency energy and, if not installed and used in accordance with the instruction manual, may cause harmful interference to radio communications. Operation of the product in a residential area is likely to cause harmful interference in which case the user will be required to correct the interference at the user's own expense.

This Class A digital apparatus complies with Canadian ICES-003.  
Cet appareil numérique de la classe A est conforme à la norme NMB-003 du Canada.

이 기기는 업무용 (A 급) 으로 전자파적합등록을 한 기기이오니 판매자 또는 사용자는 이점을 주의하시기 바라며, 가정 외의 지역에서 사용하는 것을 목적으로 합니다.

### GENERAL

Every effort has been made to ensure accuracy, however in some cases changes in the products or availability could occur which may not be reflected in this document. Christie reserves the right to make changes to specifications at any time without notice. Performance specifications are typical, but may vary depending on conditions beyond Christie's control such as maintenance of the product in proper working conditions. Performance specifications are based on information available at the time of printing. Christie makes no warranty of any kind with regard to this material, including, but not limited to, implied warranties of fitness for a particular purpose. Christie will not be liable for errors contained herein or for incidental or consequential damages in connection with the performance or use of this material.

The product is designed and manufactured with high-quality materials and components that can be recycled and reused. This symbol  means that electrical and electronic equipment, at their end-of-life, should be disposed of separately from regular waste. Please dispose of the product appropriately and according to local regulations. In the European Union, there are separate collection systems for used electrical and electronic products. Please help us to conserve the environment we live in!

Canadian manufacturing facility is ISO 9001 and 14001 certified.

### GENERAL WARRANTY STATEMENTS

For complete information about Christie's limited warranty, please contact your Christie dealer. In addition to the other limitations that may be specified in Christie's limited warranty, the warranty does not cover:

- a. Damage occurring during shipment, in either direction.
- b. Projector lamps (See Christie's separate lamp program policy).
- c. Damage caused by use of a projector lamp beyond the recommended lamp life, or use of a lamp supplied by a supplier other than Christie.
- d. Problems caused by combination of the product with non-Christie equipment, such as distribution systems, cameras, video tape recorders, etc., or use of the product with any non-Christie interface device.
- e. Damage caused by misuse, improper power source, accident, fire, flood, lightning, earthquake or other natural disaster.
- f. Damage caused by improper installation/alignment, or by product modification, if by other than a Christie authorized repair service provider.
- g. For LCD projectors, the warranty period specified applies only where the LCD projector is in "normal use." "Normal use" means the LCD projector is not used more than 8 hours a day, 5 days a week. For any LCD projector where "normal use" is exceeded, warranty coverage under this warranty terminates after 6000 hours of operation.
- h. Failure due to normal wear and tear.

### PREVENTATIVE MAINTENANCE

Preventative maintenance is an important part of the continued and proper operation of your product. Please see the Maintenance section for specific maintenance items as they relate to your product. Failure to perform maintenance as required, and in accordance with the maintenance schedule specified by Christie, will void the warranty.

**1: Introduction**

1.1 Labels and Marking ..... 1-1

1.2 General Precautions ..... 1-1

1.3 Safety Warnings and Guidelines ..... 1-2

1.4 Contacting Your Dealer ..... 1-2

1.5 Projector Overview ..... 1-3

    1.5.1 Key Features ..... 1-3

    1.5.2 List of Components ..... 1-3

**2: Installation and Setup**

2.1 Installation Considerations ..... 2-1

    2.1.1 Ventilation ..... 2-1

    2.1.2 Screen Size and Type ..... 2-1

    2.1.3 Ambient Lighting ..... 2-1

    2.1.4 Lifting, Transporting and Mounting ..... 2-2

    2.1.5 Installation Types ..... 2-2

    2.1.6 Rear Installations ..... 2-3

2.2 Installing the Projector ..... 2-4

    2.2.1 Unpacking the Projector ..... 2-4

    2.2.2 Installing the Lens ..... 2-4

        Lens Focus Adjustment for Fixed Lenses ..... 2-5

    2.2.3 Calculating Throw Distance, Position and Mount Projector ..... 2-6

        Projector Vertical and Horizontal Position ..... 2-7

        Mounting the Projector ..... 2-8

2.3 Connecting Sources ..... 2-8

    LEDS ..... 2-8

    DVI Digital Video ..... 2-8

    Dual Link Digital Video Input (DVI) Input Card ..... 2-9

    Twin HDMI Input Card ..... 2-9

    Analog BNC Input Card ..... 2-9

    Dual SD/HD - SDI Input Card ..... 2-10

    Video Decoder Input Card ..... 2-10

2.4 Power Connection ..... 2-11

    2.4.1 Connecting the projector to AC ..... 2-11

    2.4.2 Turning the Projector ON ..... 2-11

    2.4.3 Disconnecting the projector from AC ..... 2-11

2.5 Communicating With the Projector ..... 2-12

2.6 Projector Network Setup for External Communication ..... 2-12

    2.6.1 Ethernet (Recommended) ..... 2-12

    2.6.2 Mixed Network ..... 2-13

    2.6.3 RS-232 Network ..... 2-14

        Mixed Serial Network (RS-232 and RS-422) ..... 2-15

2.7 Projector Network Setup for ArrayLOC Communication ..... 2-16

2.8 Setting up the Image ..... 2-16

    2.8.1 Adjusting the Projection Lens ..... 2-16

- 2.8.2 Adjusting Image Geometry and Optical Alignment ..... 2-16
  - Basic Optical Alignment Procedure ..... 2-16
  - Folded Optics ..... 2-17
- 2.8.3 Boresight Alignment (Advanced) ..... 2-17
- 2.9 Adjust software to Optimize Image ..... 2-19
- 2.10 System Integration - GPIO Connector ..... 2-20
  - GPIO and External Devices ..... 2-20
- 2.11 Projection Lenses, Lens Mount and Other Features ..... 2-20
- 2.12 Cleaning the Lens ..... 2-21

**3: Operation**

- 3.1 Using the IR Remote ..... 3-1
  - 3.1.1 IR Remote ..... 3-2
  - 3.1.2 Wired Remote ..... 3-3
  - 3.1.3 IR Remote Commands ..... 3-3
    - Power ON/OFF ..... 3-3
    - Test ..... 3-3
    - Auto ..... 3-3
    - Channel ..... 3-4
    - Slot 1, 2, 3, and 4 ..... 3-4
    - Input ..... 3-4
    - Swap ..... 3-4
    - Contrast ..... 3-4
    - Bright ..... 3-4
    - Gamma ..... 3-4
    - Number Keys ..... 3-5
    - Help ..... 3-5
    - Menu ..... 3-5
    - OSD (On-screen display) ..... 3-5
    - Shutter ..... 3-5
    - Function Key ..... 3-5
    - Proj ..... 3-6
    - Enter ..... 3-6
    - Exit ..... 3-6
    - Arrow Keys ..... 3-6
    - Laser ..... 3-6
- 3.2 Navigating the Menus ..... 3-7
  - 3.2.1 Main Menu ..... 3-7
  - 3.2.2 On-line Help ..... 3-7
  - 3.2.3 The Global Icon ..... 3-8
  - 3.2.4 Using Slidebars and Other Controls ..... 3-8
  - 3.2.5 Editing Text ..... 3-9
- 3.3 Using Inputs and Channels ..... 3-10
  - 3.3.1 Inputs ..... 3-10
    - Switching Inputs ..... 3-10
  - 3.3.2 Channels ..... 3-11

Creating a New Channel .....	3-11
Using A Channel .....	3-12
Channel Setup Menu .....	3-12
Signal Type .....	3-13
Copying a Channel .....	3-13
Deleting a Channel .....	3-14
To Delete Multiple Channels .....	3-14
Editing a Channel .....	3-14
3.4 Adjusting the Image.....	3-15
3.4.1 Automatic Image Setup .....	3-16
3.4.2 Size and Position Menu .....	3-16
Resize Presets .....	3-16
Size .....	3-18
Vertical Stretch .....	3-18
Pixel Track .....	3-18
Pixel Phase .....	3-18
H-Position .....	3-18
V-Position .....	3-18
Keep Aspect on Auto Setup .....	3-18
Blanking .....	3-19
3.4.3 Image Settings Menu .....	3-19
Input Levels Menu .....	3-22
Advanced Image Settings Menu .....	3-25
3.4.4 Channel Setup.....	3-28
3.4.5 Configuration.....	3-29
Language .....	3-29
Output Options .....	3-29
Power Management .....	3-30
Date & Time .....	3-31
Menu Preferences .....	3-31
Communications .....	3-32
Geometry & Color .....	3-35
Brightness Uniformity .....	3-37
Diagnostics & Calibration .....	3-43
Service .....	3-45
Option Card Settings .....	3-45
ArrayLOC Menu .....	3-45
Managing Colors with ArrayLOC .....	3-55
3.4.6 Main Menu > Status.....	3-59
3.4.7 Main Menu > Secondary Input & Switching.....	3-59
3.4.8 Main Menu > Language.....	3-60
3.4.9 Main Menu > Test Pattern .....	3-60
3.5 How Color Settings Interact in a Mirage WU-L Array .....	3-61
3.6 3D .....	3-61
3.6.1 Requirements .....	3-61
Hardware .....	3-61

Software or content .....	3-62
3.6.2 Connecting the GPIO 3D Stereo sync cable .....	3-62
Connecting Two Stereo 3D Sync Inputs (Recommended for multiple sources) .....	3-62
Connecting One Stereo 3D Sync Output .....	3-63
3.6.3 Active and Passive Stereo 3D Configurations .....	3-63
3.6.4 Example of 3D Multiple Display Setup .....	3-66

**4: Menu Tree**

4.1 Menu Tree .....	4-3
4.1.1 Menu Tree Continued - Configuration .....	4-4
4.1.2 Menu Tree Continued - Geometry and Color .....	4-5
4.1.3 Menu Tree Continued - ArrayLOC .....	4-6

**5: Maintenance**

5.1 Safety Warnings and Guidelines .....	5-1
5.2 Maintaining Proper Cooling .....	5-1
5.3 Maintenance and Cleaning .....	5-1
5.3.1 Warnings and Safety Guidelines .....	5-1
5.3.2 Labels and Markings .....	5-2
5.3.3 Instructions .....	5-2
5.3.4 Projector Location .....	5-2
5.3.5 Servicing .....	5-2
5.3.6 Cleaning and Maintenance Guide .....	5-3
5.4 Light Module Replacement .....	5-4
5.5 Lens Replacement .....	5-4

**6: Troubleshooting**

6.1 Troubleshooting Guidelines .....	6-1
6.2 System Warnings / Errors .....	6-1
System Warnings .....	6-1
System Errors .....	6-2
6.2.1 LED Status Display On the Projector .....	6-2
6.2.2 Error Codes .....	6-3
6.3 Power .....	6-4
6.3.1 Projector Does Not Power ON .....	6-4
6.4 Light Module .....	6-5
6.4.1 Light Module Suddenly Goes OFF .....	6-5
6.5 Displays .....	6-5
6.5.1 The Projector is ON, but There is No Display .....	6-5
6.5.2 The Display is Jittery or Unstable .....	6-5
6.5.3 The Display is Faint .....	6-5
6.5.4 The Upper Portion of the Display is Waving, Tearing or Jittering .....	6-5
6.5.5 Portions of the Display are Cut OFF or Warped to the Opposite edge .....	6-6
6.5.6 Display Appears Compressed (Vertically Stretched) .....	6-6
6.5.7 Data is Cropped from Edges .....	6-6



6.5.8 Display Quality Appears to Drift from Good to Bad, Bad to Good ..... 6-6

6.5.9 Display has Suddenly Froze ..... 6-6

6.5.10 Colors in the Display are Inaccurate ..... 6-6

6.5.11 Display is Not Rectangular ..... 6-6

6.5.12 Display Is “Noisy” ..... 6-6

6.6 ArrayLOC ..... 6-7

6.6.1 Cannot Find Color Adjustment Controls ..... 6-7

6.6.2 Color/Image Settings Are Greyed Out ..... 6-7

6.6.3 Sensor Isn’t Calibrated (yellow alert) ..... 6-7

6.6.4 Invalid Target Gamut (yellow alert) ..... 6-7

6.6.5 Unable to Achieve Target Brightness/Gamut (yellow alert) ..... 6-7

6.6.6 Troubleshooting Tree - Color And Brightness Array ..... 6-9

6.6.7 Troubleshooting Tree - Array Brightness ..... 6-10

6.6.8 Troubleshooting Tree - Array Colors ..... 6-11

6.6.9 Bright/COLORLOC Setup Walkthrough ..... 6-12

6.6.10 Array Status Decoder & Setting the RGB Brightness Target Unit ..... 6-13

**7: Specifications**

7.1 Regulatory ..... 7-1

7.1.1 Safety ..... 7-1

7.1.2 Environmental Regulations ..... 7-1

7.1.3 Emissions ..... 7-2

7.1.4 Electromagnetic Compatibility ..... 7-2

7.1.5 Immunity ..... 7-2

7.2 Mirage WU-L Specifications ..... 7-2

7.2.1 Display ..... 7-2

7.3 Lenses ..... 7-3

7.3.1 Power Requirements ..... 7-4

7.3.2 Light Module ..... 7-4

7.3.3 Physical Specifications ..... 7-4

    Maximum Product Dimensions (L x W x H) ..... 7-4

    Product Weight ..... 7-4

7.3.4 Projector Dimensions and Mounting Information ..... 7-5

7.3.5 Environment ..... 7-7

    Operating Environment ..... 7-7

    Non-Operating Environment ..... 7-7

7.3.6 Standard and Optional Components ..... 7-8

    Standard Components ..... 7-8

    Optional Accessories ..... 7-8

7.4 Inputs ..... 7-9

**A: Interconnect Drawing**

A.1 Interconnect Drawing..... A-1

**B: Web User Interface**

B.1 Logging On ..... B-1

B.2 Navigating the Web User Interface..... B-2

    B.2.1 Help Text..... B-2

B.3 Basic Operation..... B-3

    B.3.1 Main Tab - General ..... B-3

    B.3.2 Main Tab - Status ..... B-3

    B.3.3 Tools Tab - Virtual OSD ..... B-4

        Virtual OSD Menu ..... B-5

    B.3.4 Admin Tab - System..... B-7

        Uploading a Logo File or Gamma File ..... B-8

        Creating a Backup File ..... B-8

        Restoring a File ..... B-8

        Performing a Diagnostic Test using Interrogator ..... B-9

    B.3.5 Admin Tab - Users ..... B-9

        Creating a User Name and Password ..... B-9

        Change Password ..... B-9

        Delete User ..... B-9

    B.3.6 Advanced Tabbed Page - RTE ..... B-10

        RTE Buttons ..... B-10

    B.3.7 To Add a Serial Command..... B-13

    B.3.8 About Tabbed Page ..... B-13

**C: Serial Communication**

C.1 Introduction ..... C-1

    C.1.1 Connection and Use..... C-1

C.2 Understanding Message Format..... C-1

    C.2.1 Basic Message Structure ..... C-2

        Start and End of Message ..... C-2

        Prefix Characters (Optional) ..... C-2

        Projector Numbers (Optional) ..... C-2

        Function Code ..... C-2

        +Subcode ..... C-3

        Request/Reply Symbols ..... C-3

        Other Special Functions (Optional) ..... C-3

        Data ..... C-3

        Text Parameters ..... C-4

    C.2.2 Sample Messages and their Meaning ..... C-4

    C.2.3 What is Actually Sent in a Message..... C-5

    C.2.4 Maximizing Message Integrity..... C-5

    C.2.5 Accessing Specific Channels or Inputs ..... C-6

    C.2.6 Flow Control..... C-6

C.2.7 Network Operation.....	C-7
C.3 Description Of Control Types.....	C-8
C.3.1 Subclasses .....	C-8
C.3.2 Control Groups.....	C-8
C.3.3 Access Levels.....	C-8

**D: Serial Command Reference**



# 1 Introduction

## 1.1 Labels and Marking

Observe and follow all warnings and instructions marked on the projector.

**⚠ DANGER** Danger symbols indicate a hazardous situation which, if not avoided, will result in death or serious injury.

**⚠ WARNING** Warning symbols indicate a hazardous situation which, if not avoided, could result in death or serious injury.

**⚠ CAUTION** Caution symbols indicate a hazardous situation which, if not avoided, could result in minor or moderate injury.

**NOTICE:** Information provided with this heading alerts users to key points of interest not related to personal injury.

## 1.2 General Precautions



The projector is a class 2M source of visible and invisible LED radiation. Directly Viewing the LED output with certain optical instruments (e.g. eye loupes, magnifiers and microscopes) within a distance of 100mm (3.94") may pose an eye hazard.

**⚠ CAUTION** The projector is a class 2M source of visible and invisible LED radiation. Directly viewing the LED output with certain optical instruments (for example, eye loupes, magnifiers and microscopes) within a distance of 100 mm may pose an eye hazard.

**⚠ CAUTION** Power should always be disconnected from the illumination module before servicing, to avoid the possibility of inadvertent exposure to visible and invisible LED radiation. Directly viewing the illumination module optical output through certain optical instruments (for example, eye loupes, magnifiers and microscopes) within a distance of 100mm may pose an eye hazard.

**⚠ WARNING** Disconnect the AC cord before disconnecting the light module from the Projector Head Module (PHM).

### 1.3 Safety Warnings and Guidelines



Be aware of the caution label on the projector warning of possible eye hazard if the projected visible and invisible LED radiation light is viewed directly through certain optical instruments at close range. Figure 1-1 indicates where the label is located.

**CAUTION** The projector is a class 2M source of visible and invisible LED radiation. Directly viewing the LED output with certain optical instruments (for example, eye loupes, magnifiers and microscopes) within a distance of 100 mm may pose an eye hazard.

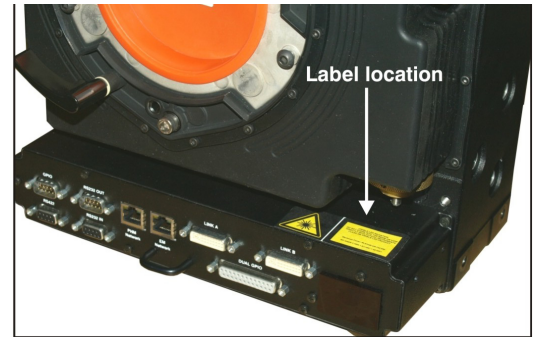

Figure 1-1 LED Caution Label Location

### 1.4 Contacting Your Dealer

If you encounter a problem with your Christie projector, contact your dealer. To assist with the servicing of your projector, enter the information in the tables and keep this information with your records.

**Table 1.1 Purchase Record**

<b>Dealer:</b>
<b>Dealer or Christie Sales/Service Contact Phone Number:</b>
<b>Projector Serial Number*:</b>
<b>Purchase Date:</b>
<b>Installation Date:</b>

\* The serial number can be found on the license label located on the back of the projector.

**Table 1.2 Ethernet Settings**

<b>Default Gateway</b>	
<b>DNS Server</b>	
<b>Projector IP Address</b>	
<b>Subnet Mask</b>	

## 1.5 Projector Overview

**NOTE:** The rubber mount has been removed from around the lens mount for illustration purposes.

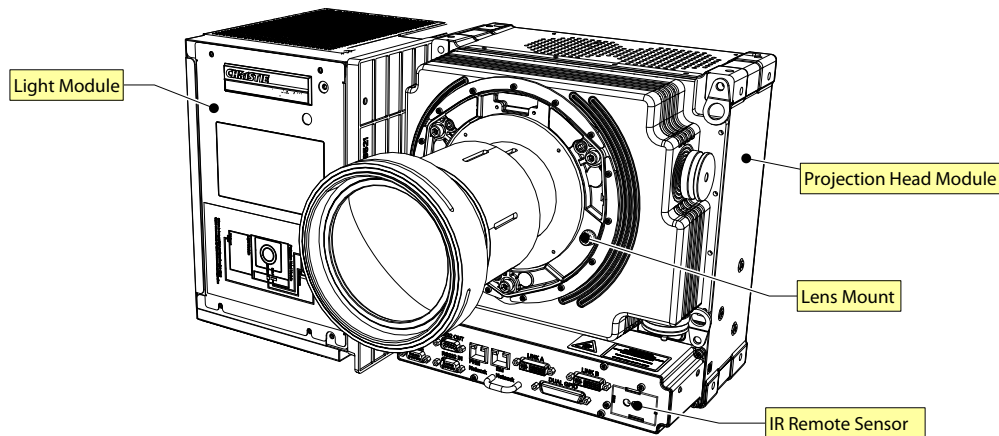

Figure 1-2 Mirage WU-L Projector

### 1.5.1 Key Features

- Native WUXGA, 1920 x 1200 resolution
- 10-bit image processing module
- Display of RGB, NTSC, PAL, and SECAM video inputs and HDTV formats
- Edge Blending ability using software for seamless displays
- Dual frequency IR sensor for use with standard IR remote and optional long-range dual frequency remote
- Memory for up to 99 custom “channels” (source setups)
- Intuitive on-screen menu system
- 3D functionality using built-in GPIO port: Native 3D, Frame Doubled 3D, and Dual Input 3D
- LED display for projector status monitoring
- Multiple control options including RS-232 and RS-422
- On-board ChristieNET™ software
- Universal AC input 100-240 VAC, 50/60Hz
- Dual Image Processing Card (DIPC)

### 1.5.2 List of Components

Make sure these components were received with the projector:

- Projector Head Module (PHM), with attached Illumination Module (LM)
- Electronics Module (EM)
- Warranty Card
- Web Registration Form
- Line Cord (rated, North American)

**NOTE:** Each projection system requires a User Kit (P/N: 125-104106-xx). If you did not receive a User Kit or if you want to purchase additional kits, you can order them separately.





## 2 Installation and Setup

This section explains how to install, connect and optimize the projector display.

### 2.1 Installation Considerations

- Ambient temperature must stay below 40°C (95°F). Changes in temperature can cause drifts in the projector circuitry, which may affect performance. Keep the projector away from heating and air conditioning vents.
- Keep the projector away from all devices radiating electromagnetic energy. For example, motors and transformers, slide projectors, speakers, power amplifiers and elevators.
- Use an optical mirror for rear screen installations to shorten the optical light path and use less space in the projection room. For more information about projector installations, see [2.1.5 Installation Types](#).

#### 2.1.1 Ventilation

**NOTICE:** *Caution do not obstruct the air exchange to the projector.*

The projector vents provide ventilation, both for intake and exhaust. Do not block or cover these openings. Do not install the projector near a radiator or heat register, or within an enclosure. Make sure there is a minimum clearance of 25cm (10”) on the left, right, top and rear sides of the projector.

#### 2.1.2 Screen Size and Type

Screens with an aspect ratio of 16:10 are recommended for use with these projectors. To fill a screen with an image, the aspect ratio of the screen must be equal to the aspect ratio of the image.

Diffused and optical screens are best suited for rear screen installations. A diffused screen has a surface which spreads the light striking it. Purely diffused screens have a gain of less than 1. Optical screens take light from the projector and redirect it to increase the light intensity at the front of the screen.

#### 2.1.3 Ambient Lighting

The contrast ratio of projected images is reduced when light directly strikes the screen. Eliminate all stray light sources from the viewing area.

### 2.1.4 Lifting, Transporting and Mounting

**⚠ CAUTION** Mount the projector to a sturdy, flat surface that fits the entire projector. Use all four mounting points to secure the projector to the surface. Maintain a minimum clearance of 25cm (10”) around the projector, called a “stay out zone”, for air circulation and clearance for cable connections to the input panel. Insufficient stay out zone clearance can cause the projector to overheat during operation and/or place undue stress on source connections.

The projector should be lifted by 2 people. Use a stable cart to transport the projector. Refer to the drawings given for your specific projector model for the mounting hole location and other technical information and restrictions which may be useful during installation.

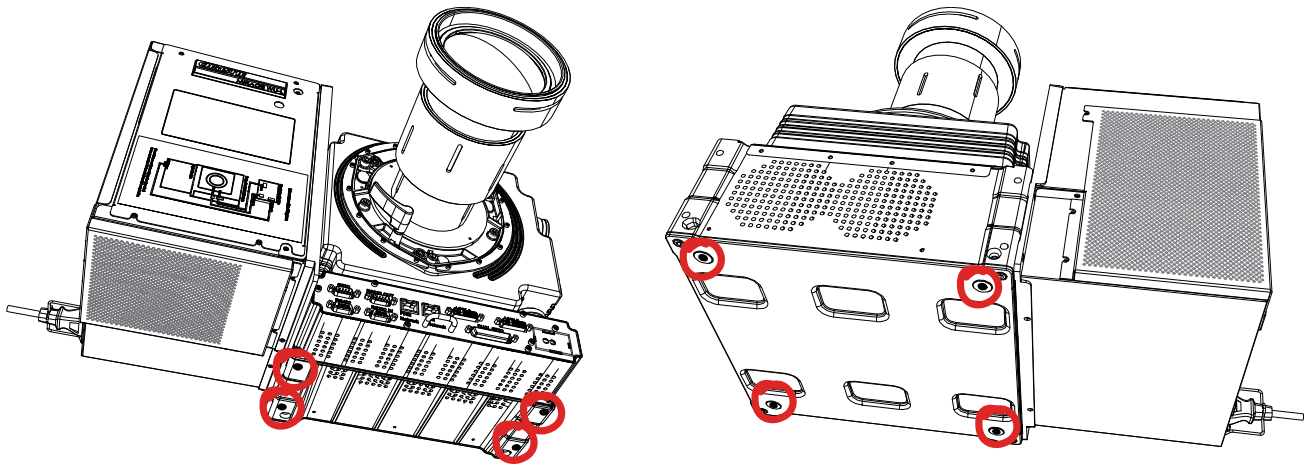

Figure 2-1 Mounting Holes

### 2.1.5 Installation Types

This topic provides recommendations for getting optimum performance from your Christie projector.

**Table 2.1 Front Screen / Floor Mount Installation**

Advantages	Considerations
<ul style="list-style-type: none"> <li>• Easy to set up.</li> <li>• Can be moved or changed quickly.</li> <li>• Easy to access.</li> </ul>	<ul style="list-style-type: none"> <li>• Shares floor space with audience.</li> </ul>

**Table 2.2 Front Screen / Inverted Mount (ceiling) Installation**

Advantages	Considerations
<ul style="list-style-type: none"> <li>• Does not take up audience space.</li> <li>• Projector is unobtrusive.</li> <li>• Projector cannot be accidentally moved.</li> </ul>	<ul style="list-style-type: none"> <li>• Cannot be moved or changed quickly.</li> <li>• Access to the projector is limited.</li> </ul>

**Table 2.3 Rear Screen / Floor Mount Installation**

Advantages	Considerations
<ul style="list-style-type: none"> <li>• Projector is hidden.</li> <li>• Projector is easily accessed.</li> <li>• Good ambient light rejection.</li> </ul>	<ul style="list-style-type: none"> <li>• Requires a separate room or enclosure.</li> <li>• Higher installation cost.</li> </ul>

**Table 2.4 Rear Screen / Inverted Mount (ceiling) Installation**

Advantages	Considerations
<ul style="list-style-type: none"> <li>• Projector is hidden.</li> <li>• Good ambient light rejection.</li> </ul>	<ul style="list-style-type: none"> <li>• Requires a separate room.</li> <li>• Higher installation cost.</li> <li>• Access to the projector is limited.</li> </ul>

**Table 2.5 Rear Screen / Floor Mount with Mirror**

Advantages	Considerations
<ul style="list-style-type: none"> <li>• Projector is hidden</li> <li>• Good ambient light rejection.</li> <li>• Requires less space behind screen than other rear screen installations.</li> </ul>	<ul style="list-style-type: none"> <li>• Requires a separate room or enclosure.</li> <li>• Higher installation cost.</li> <li>• Complex installation.</li> </ul>

### **2.1.6 Rear Installations**

There are 2 basic types of rear screen installations:

- A diffused screen has a surface, which spreads the light striking it. Purely diffused screens have a gain of less than 1.0. The advantage of the diffused screen is its wide viewing angle, similar to that of a flat screen for front screen projection. This type of screen is suitable when a wide viewing angle is required but there is low ambient room lighting.
- Optical screens take light from the projector and redirect it to increase the light intensity at the front of the screen. This reduces it in other areas. A viewing cone, similar to that of a curved front screen installation is created. This type of screen is better suited for brightly lit rooms where the audience is sitting within the viewing cone.

## 2.2 Installing the Projector

This section gives the installation sequence for the *Mirage WU-L* projector.

### 2.2.1 Unpacking the Projector

The projector is shipped assembled with the projection lens shipped separately. The lens must be installed prior to setting up the projector.

1. Remove the projector from the box and packing material.

**NOTE:** Save packing material for at least 1 projector in case a projector needs to be shipped for service.

2. Connect the Electronics Module to the Projector Head Module and Light Module.

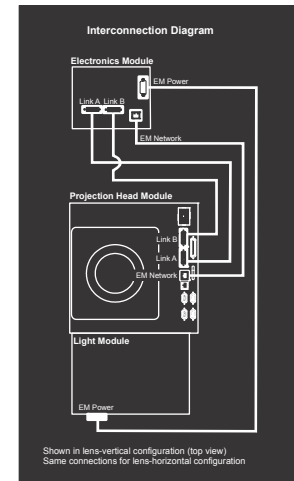

Figure 2-2 Module Interconnections

### 2.2.2 Installing the Lens

1. Remove the rear lens cap from the lens. Keep the front lens cap on the lens.
2. Rotate the lens clamp to the OPEN position (**Figure 2-3**).



Figure 2-3 Rotate to Open



Figure 2-4 Security Screws

3. Remove and retain the (2) security screws from the lens mount, see **Figure 2-4**.
4. Align the lens interface plate with the lens mount. Fully insert the assembly straight into the lens mount opening without turning. **NOTICE:** Ensure the lens IS NOT inserted at an angle as this can cause damage.
5. Rotate the lens clamp to the CLOSED position **before** fastening the security screws.
6. Fasten the security screws (**Security Screws**). **NOTICE:** Security screws **MUST** be installed.
7. Remove the front lens cap.

For more information concerning lenses, see [2.11 Projection Lenses, Lens Mount and Other Features](#) and [2.12 Cleaning the Lens](#).

### Lens Focus Adjustment for Fixed Lenses

This section describes best practices for lens focus adjustment of the 0.64:1 WUXGA lens (PN: 002-120444-02) and the 0.75:1 (PN: 002-120415-01). The lenses have focus and field curvature correction to sharpen the projected image. Failure to properly adjust lens focus results in an image that is not uniformly focused and contains geometric distortion.

1. Loosen the main locking screw and the focusing screw.
2. Adjust the focusing screw for best focus in the image center.
3. Loosen the field curvature locking screw and adjust the field curvature focusing ring to sharpen the image corners. Refer to the image below as an aid to gage the specific preset for your screen size.
4. Finally the focus screw should be "tweaked" for best overall screen focus.
5. Although it is not necessary, you may want to retighten the main locking screw. **NOTE:** Use a maximum of 4in.-lbs to tighten the main locking screw.



0.64: WUXGA/0.69:1 SXGA+ Lens  
Part Number: 002-120444-02

Figure 2-5 0.64:1 WUXGA Lens

### 2.2.3 Calculating Throw Distance, Position and Mount Projector

Throw distance is the distance measured from your projector to the screen. This calculation determines if there is enough room to install your projector with a desired screen size and if the image will be of the right size for your screen. To estimate the throw distance take the horizontal width of the screen and multiply it by the lens throw ratio. The result determines approximately the distance the projector should be positioned from the screen to project a focused image large enough to fill the screen. For example, using a 1.2:1-1.6:1 zoom lens set at its widest (1.2:1) throw ratio, throw distance would roughly be 1.2 x screen width.

**IMPORTANT:** Use the lens and screen size to calculate the precise throw distance. Due to lens manufacturing tolerances for lens focal length, actual throw distance can vary  $\pm 2\%$  between lenses with the same nominal throw ratio.

**Table 2.6 Lens Types, Offsets and Throw Distances**

CHRISTIE Lens Throw Distance	Offset Percentage (Offset Pixels)		Specified Throw Distance Range			
	Horizontal	Vertical	Inches		Meters	
			Min	Max	Min	Max
0.64:1	11% (211)	26% (312 px)	40	120	1.0	3.1
1.2-1.6	75% (1440)	150% (1800 px)	59	213	1.5	5.4
0.75:1	75% (1440)	134% (1608 px)	28	102	0.7	2.6

**NOTES:**

- 1) Offsets are subject to  $\pm 7\%$  centering tolerance.
- 2) Image size outside the specified width range may result in reduced image quality.
- 3) Throw distance is measured from the marked exit pupil position on the lens (see Figure 2-5) to the screen. Throw ratio is defined as:

$$\text{Throw Ratio} = \frac{\text{throw distance}}{\text{screen width}} \pm 2\%$$

- 4) 100% offset is defined as having all pixels shifted beyond the axis.
- 5) Offsets are measured from optical lens centre, which may not coincide with mechanical centre % offset is defined as:

$$\% \text{ Offset} = \frac{\# \text{ of pixels of offset}}{\text{half vertical panel resolution}} \times 100$$

**Projector Vertical and Horizontal Position**

The projection lens and the screen type determine the vertical and horizontal position of your projector in relation to the screen. Ideally, you should position the projector perpendicular to the screen to make the image appear rectangular instead of keystone (trapezoidal). You can offset vertical position of the image (move it above or below the optical axis) by adjusting the lens mount. The type of projection lens you install determines the amount of available vertical offset. Vertical offset can be expressed as the percent of half the image height or the number of pixels of shift from lens center.

**NOTES:**

1) Offsets are subject to ±7% centering tolerance.

2) % offset is defined as: 
$$\% \text{ Offset} = \frac{\# \text{ of pixels of offset}}{\text{half vertical panel resolution}} \times 100$$

The horizontal position of the image can also be offset (moved to the left or right of optical center) by adjusting the lens mount. The amount of horizontal offset available depends on the lens installed and if the image has already been vertically offset. Horizontal offset can be expressed as the percent of half the image width or the number of pixels of shift to one side of lens center.

**Example of Horizontal Offset (WUXGA pixels represented)** Shaded area = projected image

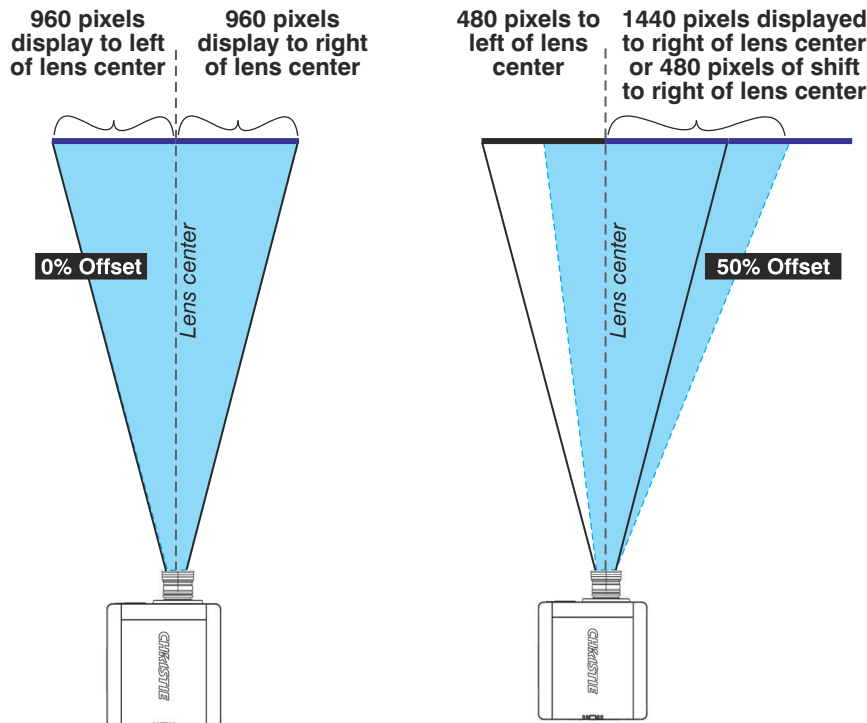

#1 In this example, no offset is applied; therefore, half of the image appears to the left of lens center and half appears to the right.

#2 In this example, 50% offset is applied; therefore, 3/4 or 75% of the image appears to the one side of the lens center.

## Mounting the Projector

**NOTICE:** Use only the CHRISTIE approved projector mounts designed for your projector. Refer to the installation instructions and safety guidelines provided with in the kit.

There are several methods for mounting the projector. In typical front and rear screen installations the projector can be mounted to a secure and level surface. The projector can be mounted in any orientation without affecting performance.

## 2.3 Connecting Sources

All source connections are made to the input panel of the Electronics Module. Each input is labeled for easy identification. Using the correct cable(s), connect your source. An interconnection label is available for reference on the light module. Sources are connected to the *Input Panel* located at the top of the EM. The Input Panel has slots for 1 image processor board and up to 4 input cards, and comes standard with 2 slots populated. The input cards are hot swappable; they can be plugged in and out while the projector is running. The image processor should only be replaced when the projector is OFF or when it is in STANDBY mode.

The video card that is installed in your projector determines the type of video source you can use. These video cards are supported:

- High-Definition Multimedia Interface/Twin HDMI (High-Definition Multimedia Interface)
- Analog BNC
- Dual SD/HD-SDI (Serial Digital Interface)
- Dual Link DVI
- Video Decoder

These cards slide into any of the available option slots. One or more of the option slots may be used with any combination of option cards, including multiples of the same card type. One input is active on any card at a single time, except the Dual HDMI and Dual SD/HDSDI cards, which support up to 2 active signals on 1 card.

**NOTE:** Use only high-quality shielded cables for all connections.

### LEDS

LEDs are located on the faceplate of each input card and indicate the following:

- Power ON - Green
- Signal Valid - Green
- Signal Invalid - OFF

### DVI Digital Video

Use the DVI-I connector to connect either analog or digital video devices to the projector. Use a cable with DVI-I connectors at both ends to connect devices that transmit digital and analog video signals such as satellite receivers and digital cable TVs. **NOTE:** For true digital output from devices that transmit digital signals, connect to the DVI-I connector.



**Dual Link Digital Video Input (DVI) Input Card**

This card accepts a maximum 330MHz DVI-D or 165MHz HDMI signal via the DVI-I connector without High-Bandwidth Digital Content Protection (HDCP) and analog video signals over the DVI-I or 15-pin VGA connector. The module can simultaneously support a digital signal on the DVI input and an analog signal on the VGA port; however, it does not support 2 analog signals at the same time. There are 4 LEDs on the module faceplate. **PWR** indicates power is applied and the card is initialized, and the other 3 LEDs on the right-side of the corresponding connectors indicate that a valid signal has been detected.

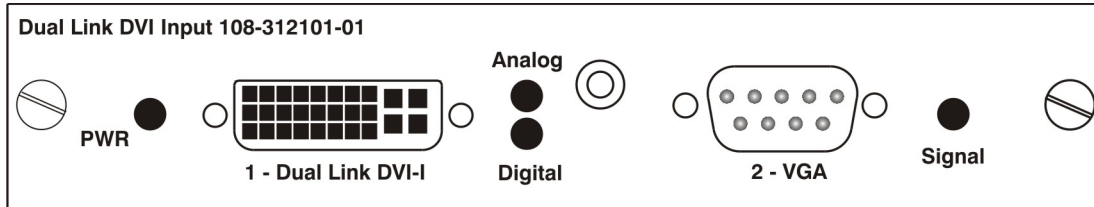

**Twin HDMI Input Card**

This card accepts 1 or 2 HDMI inputs, and can route one or both inputs to the card’s outputs without High-Bandwidth Digital Content Protection (HDCP). Any input from any card can be looped out of this card. The output label ‘1-OUT’ loops out the main image being displayed on the projector. The output labelled ‘2-OUT’ loops out the image displayed in the picture in picture (PIP). Any input from any optional input card can be looped out of this card. There are five LEDs on the module faceplate. The PWR on the left side indicates power is applied, and that the card is initialized. The LEDs to the right side of the corresponding connectors indicate that a valid signal is detected. In the case of the outputs, the LED indicates a signal is currently being looped out.

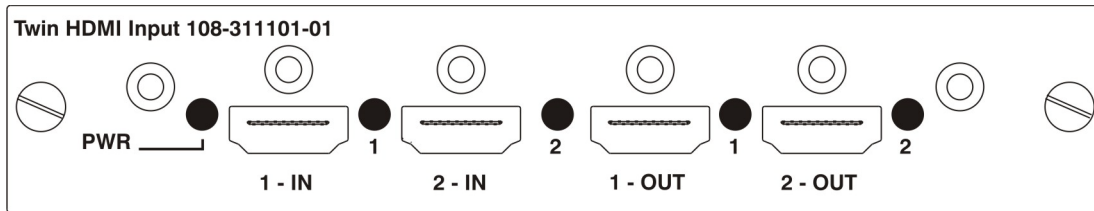

**Analog BNC Input Card**

This card accepts several types of sync modes. In 5-wire sync mode all 5 BNC connectors are used. If H and V connectors are swapped, this card will still operate normally. An analog graphic source such as a VGA from a PC can be connected. The card can operate in 4-wire sync mode, which accommodates 4-wire RGBC sources. The composite sync cable can be connected to either the H/C BNC or the V BNC. The card supports 3-wire RGB or YPBPr sync modes, sometimes called sync-on-Green (SOG). In this mode the H/C and V connectors are not used. The sync is connected to the Green/Y BNC connector. This card offers no loop out capability. There are 2 LED’s on the module faceplate. PWR indicates power has been applied and the card is initialized, signal indicates a valid signal has been detected.

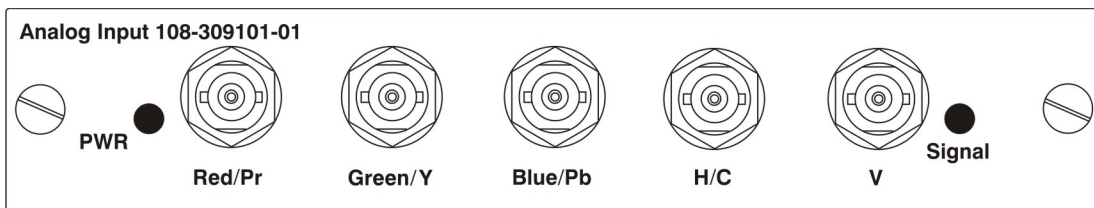

### Dual SD/HD - SDI Input Card

This card accepts both standard-definition (SD) and high-definition (HD) serial-digital-interface (SDI) signals from one of two standard-definition (SD) or high-definition (HD) SDI sources. Both single-link HD and dual-link HD signals are accepted. The card has two SD/HD-SDI outputs, each of which is “loop through” for its respective input. There are three LEDs on the module faceplate. PWR indicates power has been applied and the card is initialized, and the two signal LEDs indicate a valid signal has been detected on the respective input.

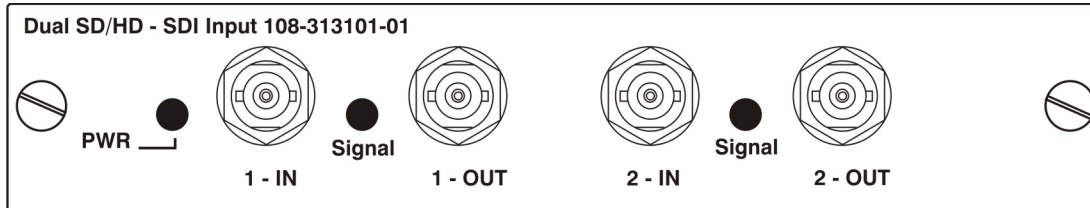

### Video Decoder Input Card

This card accepts and decodes standard definition (SD) video. This includes CVBS (composite video), S-Video, and component sources. This card supports as many as six video signals, four of them on BNC connectors and two on four-pin mini-DIN connectors. Each mini-DIN connector accepts one S-Video signal. The first BNC accepts composite video (only), while the remaining three BNCs can be grouped to allow one of the following combinations:

- 3 CVBS sources on 4, 5 & 6
- 1 CVBS source, 1 S-Video source: Luma (Y) connected to 4 (Sy) and Chroma (C) connected to 6 (Sc)
- 1 YPbPr source: component signal on 4(Pr), 5(Y) & 6(Pb)

The video decoder input card has 8 LED indicators. The PWR LED indicates that the module is installed properly, and has been successfully configured. The YPbPr LED indicates that a valid component signal has been detected on inputs 4, 5, and 6 (Component input grouping must also be selected in the projector’s menu - see [Section 3 Operation](#)). The remaining LEDs are each associated with one of the inputs and indicate a valid signal has been detected on that input.

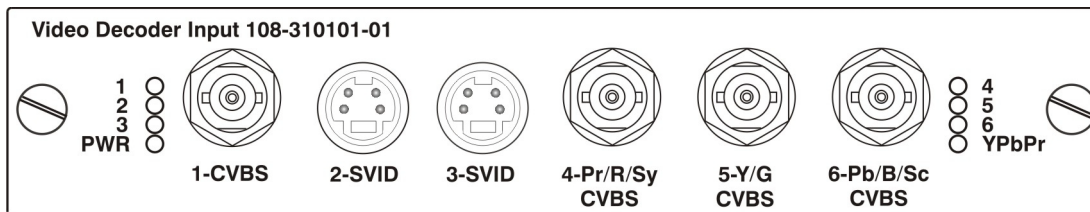

## 2.4 Power Connection

**⚠ CAUTION** The projector is a class 2M source of visible and invisible LED radiation. Directly viewing the LED output with certain optical instruments (for example, eye loupes, magnifiers and microscopes) within a distance of 100 mm may pose an eye hazard

**⚠ WARNING** Do not operate if the AC supply and cord are not within the specified voltage and power range. The North American rated line cord is supplied with this projector. For all other regions, use only a regionally approved line cord, power plug and socket. Do not use a damaged line cord.

### 2.4.1 Connecting the projector to AC

The input voltage to the projector must be capable of 100-240 VAC. Use only a correctly rated line cord.

**NOTE:** Do not use a line cord or AC supply not in the specified voltage and power range. See [Section 7 Specifications](#) for projector power requirements.

1. Connect an approved line cord to the projector AC receptacle, located on the Light Module. Use only the line cord supplied with the projector or a power cord of correct ratings that comply with regional standards.
2. Connect the 3-pronged end of the line cord to a grounded AC outlet. The outlet must be near the equipment and easily accessible.

### 2.4.2 Turning the Projector ON

1. Flip the power switch on the LM (Light Module) **ON**. The projector takes about 2 minutes to initialize. The status light beside the LED window turns yellow.

**NOTE:** The Electronics Module has a circuit breaker which is generally left ON. Certain error conditions can turn the circuit breaker off. The circuit breaker must be ON for proper projector function.

2. Using the remote keypad, press the **Power** button, and then the **UP** arrow.
3. Press one of the input keys on the remote to select and display the image for the source connected in [2.3 Connecting Sources](#). For more information on the key functionality, see [3.1.1 IR Remote, on page 3-2](#).

For more information about sources, see [2.3 Connecting Sources, on page 2-8](#).

### 2.4.3 Disconnecting the projector from AC

**⚠ WARNING** Do not turn the main power switch to the **OFF** position or disconnect the projector until the cooling fans have stopped.

1. Stop the projector.
2. After the internal cooling fans stop, move the main power switch on the light module to the OFF position.
3. Disconnect the line cord from the wall outlet.

## 2.5 Communicating With the Projector

To use the remote control, point the remote at the display screen or the projector IR sensor. To use the remote with the cable, connect the cable to the remote and to the connector labeled **REMOTE** on the Electronics Module input panel. Check **Wired Keypad Enabled** in the **Communications** menu.

As an alternative to the projector keypad or remote, communicate with the projector using a PC or other controller. Commands and feedback are sent to the projector's Electronics Module using Ethernet or serial links (RS232 and RS422). **NOTE:** *Do not connect to the Projector Head Module (PHM).*

## 2.6 Projector Network Setup for External Communication

This section outlines a several ways to set up a Mirage WU-L projector network for external communication.

**IMPORTANT:** *To complete the projector network setup you will also need to connect the projectors together for arrayLOC communication and functions. See [ArrayLOC Network on page 3-53](#).*

### 2.6.1 Ethernet (Recommended)

In the Ethernet network the controller communicates with each projector separately.

To add a projector to an Ethernet network:

1. Connect a standard CAT5 Ethernet cable between the controller (or Ethernet hub) and the Ethernet port on the projector Electronic Module.
2. Set the IP address in **Configuration > Communications > Ethernet Settings**. See [Ethernet Settings on page 3-34](#).
3. Set **Configuration > Communications > Network Routing** to *Separate*. See [Network Routing on page 3-33](#).

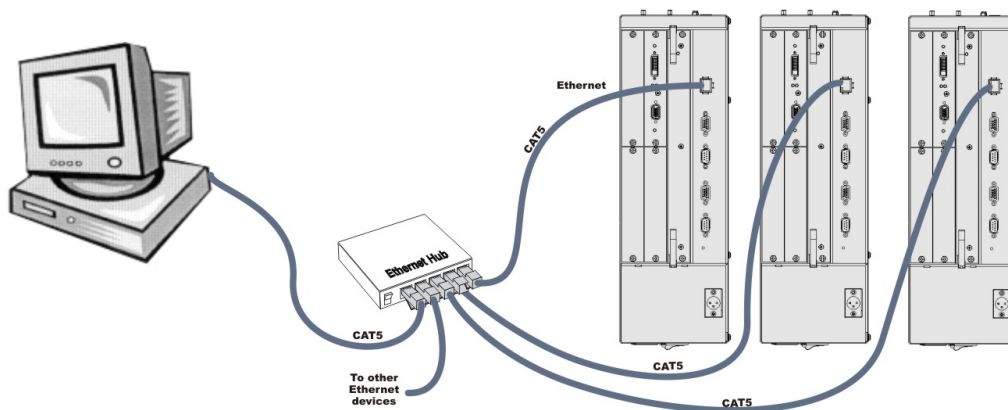

### 2.6.2 Mixed Network

In the mixed network the controller can communicate with the first projector and the command can be relayed to each serially connected projector. This configuration is useful if you are using a non-RS232 controller with the RS232 linking available between these projectors. The example shows both an RS422-compatible controller and an Ethernet-connected PC for working with a network of projectors linked using their RS232 in/out ports.

- Connect the controller to one projector:
  - A standard CAT5 Ethernet cable between the controller (or Ethernet hub) and the Ethernet port on the Electronic Module
  - An RS-422 serial cable between the PC and the RS422 IN (pictured).
- Connect a serial cable between the RS232 OUT connector of the first projector Electronics Module and the RS232 IN connector of the next projector Electronics Module. Connect the remaining projectors. RS232 communication cables must be good quality and no more than 25 feet in length.
- If you connected the controller, using an Ethernet cable, set the IP address in **Configuration > Communications > Ethernet Settings**. See [Ethernet Settings on page 3-34](#).
- Set the serial options in **Configuration > Communications**. See [Communications on page 3-32](#).
- Set **Configuration > Communications > Network Routing**. See [Network Routing on page 3-33](#).
  - To relay commands to all projectors set Network Routing to *All Join*.
  - To isolate just RS422 communications, select *RS232 and Ethernet Joined*. Only projector #3 will respond to the RS422 controller.
  - To isolate just Ethernet communications, select *RS232 and RS422 Joined*—only projector #1 will respond using Ethernet.

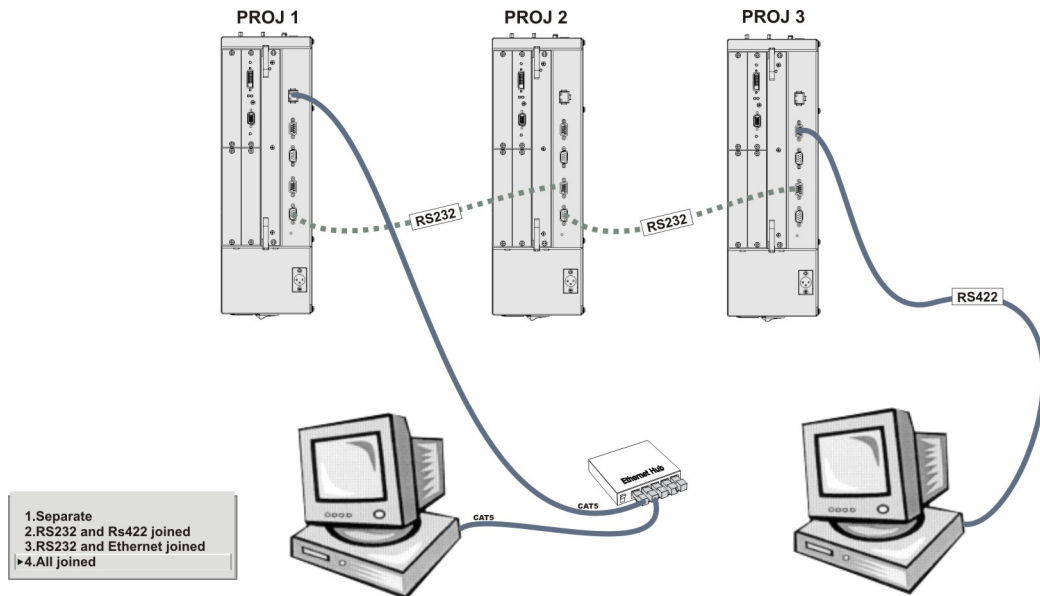

### 2.6.3 RS-232 Network

In the RS-232 network the controller can communicate with the first projector and the command can be relayed to each serially connected projector. **NOTICE:** *Using the wrong type of serial cable can damage the projector.*

- Connect the controller to one projector using serial cable between the PC and the RS232 IN port on the Electronic Module.
- Connect a serial cable between the RS232 OUT connector of the first projector Electronics Module and the RS232 IN connector of the next projector Electronics Module. Connect the remaining projectors. RS232 communication cables must be good quality and no more than 25 feet in length.
- Set the RS-232 serial options in **Configuration > Communications**. See [Communications on page 3-32](#).
- Set **Configuration > Communications > Network Routing** to one *RS232 and RS422 Joined*. See [Network Routing on page 3-33](#).

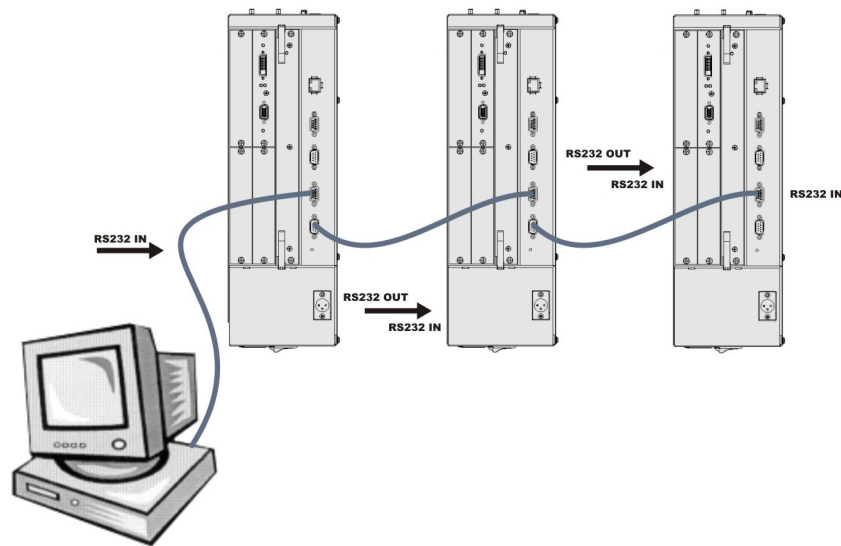

**Mixed Serial Network (RS-232 and RS-422)**

RS-422 serial communication is better over long distances than RS-232 communication. Use the RS-422 port only if your device has RS-422 capability. Always read the equipment literature before connecting.

**NOTICE:** Connecting to the RS-422 port with incompatible equipment, including the wrong type of serial cable, can damage the projector.

In the RS-422 network the controller can communicate with the first projector and the command can be relayed to each serially connected projector.

- Connect the controller to one projector using RS-422 serial cable between the PC and the RS-422 IN port on the Electronic Module.
- Connect an RS-232 serial cable between the RS232 OUT connector of the first projector Electronics Module and the RS232 IN connector of the next projector Electronics Module. Connect the remaining projectors using RS232 cables. RS232 communication cables must be good quality and no more than 25 feet in length.
- Set the serial options in **Configuration > Communications**. See [Communications on page 3-32](#).
- Set **Configuration > Communications > Network Routing** to one *RS232 and RS422 Joined*. See [Network Routing on page 3-33](#).

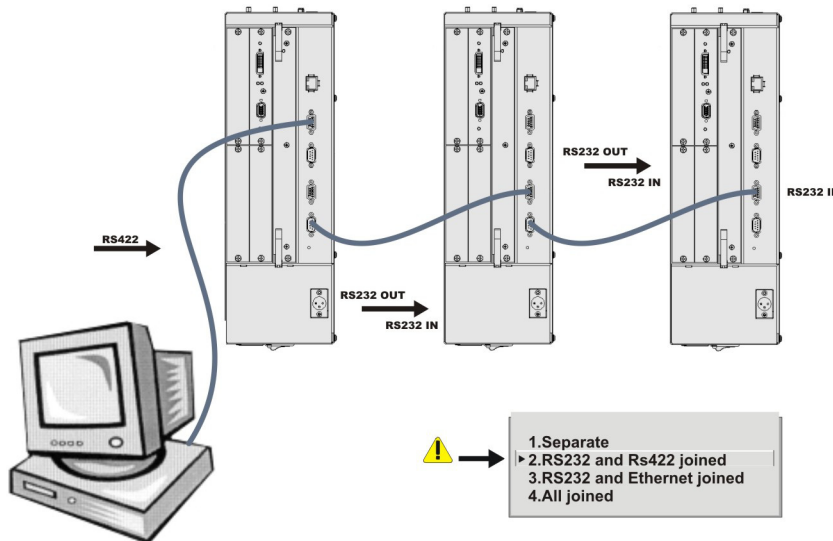

## 2.7 Projector Network Setup for ArrayLOC Communication

See the Integration Guide for detailed information about arrayLOC setup.

## 2.8 Setting up the Image

### 2.8.1 Adjusting the Projection Lens

**NOTICE:** *Lock lens adjustments to prevent unnecessary tampering.*

Loosen the adjustment locks on the lens barrel before making adjustments.

### 2.8.2 Adjusting Image Geometry and Optical Alignment

Only perform image alignment once the projector is fully assembled and powered up in its final location. Basic image alignment ensures the image reflected from the DMD is parallel to and well-centered with the lens and screen. This initial optical alignment is the foundation for optimizing images on the screen, and must be completed before final boresight adjustments. Before beginning, ensure that the projector is properly positioned relative to the screen.

#### Basic Optical Alignment Procedure

1. **Display a test pattern:** Appropriate for analyzing image focus and geometry, such as the “*framing*” test pattern showing the cross-hair centered across the image. Press the **Test** key on the remote keypad.
2. **Coarse focus:** Do a quick preliminary focus and (if available) zoom adjustment with the primary lens. Do not worry about consistency across the image at this point, just center focus. It is good practice to have the zoom adjustment collar and the focus adjustment collar in the center of its range.
3. **Center the image in the lens:** Holding a piece of paper at the lens surface, adjust offsets as necessary until the image is centered within the lens perimeter. A full white field works best for this.
4. **If necessary, center the image on the screen:** If the projector is mounted off-center to the screen axis, then offset the lens as much as required. Aim the projector over slightly towards the center of the screen, but use caution, as too much tilt will cause excessive keystone distortion. Lens offset will not.
5. **Re-check side-to-side leveling:** With the framing pattern on screen, double-check projector leveling so the **top edge** of the image is parallel to the top edge of the screen.
6. **Throw distance:** Ensure that the projector is positioned in the throw distance range for the lens in use.



**Folded Optics**

In rear screen applications where space behind the projector is limited, a mirror may be used to fold the optical path, see **Figure 2-6**. The position of the projector and mirror must be accurately set - if considering this type of installation contact Christie Customer Support for assistance.

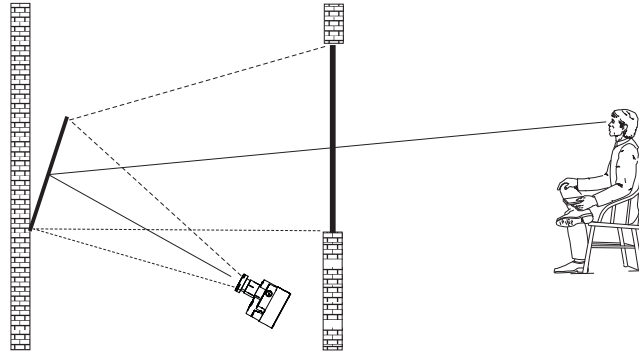

Figure 2-6 Folded Optical Path

**2.8.3 Boresight Alignment (Advanced)**

1. Display the Boresight Test Pattern by pressing the **Test** key on the remote keypad, then use the **Left** arrow key to cycle to Boresight, see **Figure 2-7**.

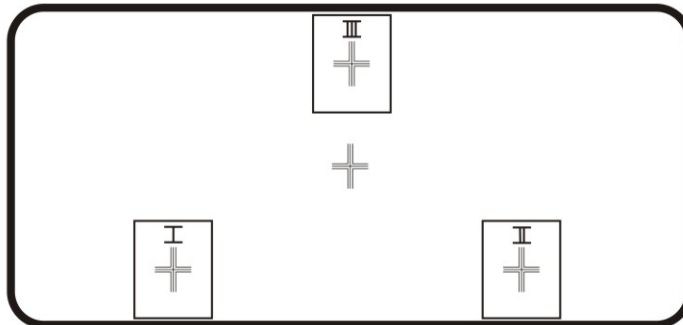

Figure 2-7 Boresight Pattern

2. Focus the image on the cross-hair pattern at the image center. Evaluate the focus on cross-hair image I and II. If all three images are in focus, no further action is required. If boresight is required see step 3.

3. If boresight is required, see **Figure 2-8** to understand how the adjustment screws on the lens mount affect the corresponding cross-hairs on the test pattern.
4. Use a 5mm Allen key to loosen the three locking setscrews on the lens mount, see **Figure 2-9**.  
**NOTE:** *The setscrews must be backed out several turns, so that they do not contact the inner lens mount plate.*

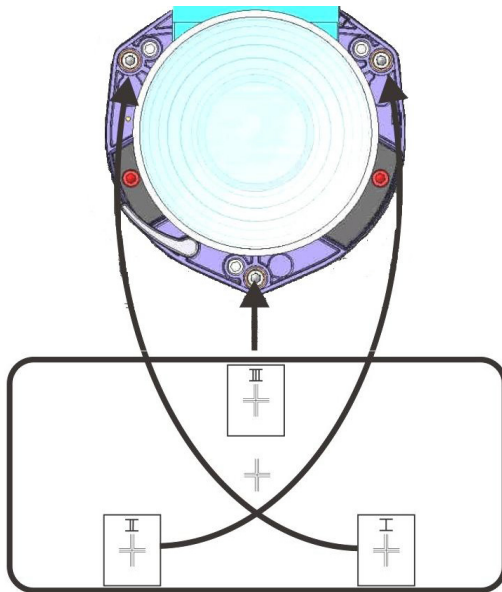

Figure 2-8 Cross-Hair Pattern

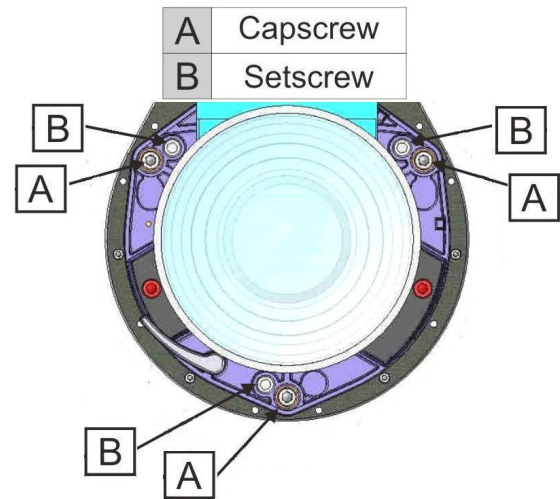

Figure 2-9 Screw Locations

5. Fine tune the focus of cross-hair pattern I by adjusting the appropriate capscrew, see **Figure 2-9**. Adjust until the cross-hair image is in focus with minimal flare.
6. Adjust cross-hair pattern II, by adjusting the appropriate capscrew, see **Figure 2-9**. Adjust until the cross-hair image is in focus with minimal flare.
7. Adjust cross-hair pattern III, by adjusting the appropriate capscrew, see **Figure 2-9**. Adjust until the cross-hair image is in focus with minimal flare.
8. Repeat steps 5, 6 and 7 as required until all three cross-hair patterns are in equal sharp focus. If the boresight is acceptable, see Step 11. If the boresight does not appear to be converging to an acceptable level of image quality or if the lens will not focus over the correct range of throw distances, then the boresight requires coarse adjustment, see step 9.
9. The original factory boresight can be recovered approximately by positioning the 3 setscrews, see **Figure 2-9**. Position the setscrews flush with the front face of the lens mount plate and in contact with the inner lens mount plate, see **Figure 2-10**. This may require adjusting both setscrews and capscrews.
10. If further action is required. Repeat step 2.

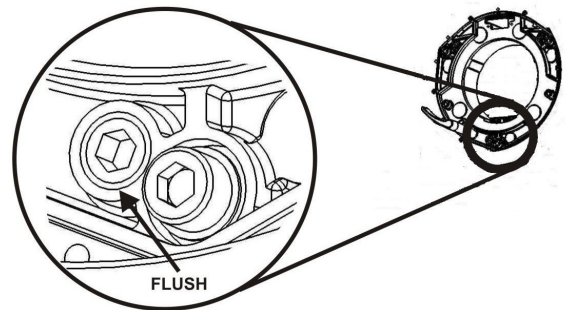

Figure 2-10 Position Setscrew Flush

11. Lock the set screws and re-check the boresight quality. Tighten the setscrews enough to ensure they will not shift.
12. When the image is focused, lock adjustments in place by tightening the adjustments until just tight.

## 2.9 Adjust software to Optimize Image

**NOTES:** 1) See Section 3 for details on accessing and adjusting individual settings. 2) Unless otherwise indicated, instructions apply to all projector models in stand-alone or multi-projector configurations.

1. Display an external signal.
2. Select **Screen Image Orientation** in **Configuration > Output Options** and change the orientation of the displayed image to suit the installation.
3. Assign projector ID number(s).
4. Modify options in the **Main menu**. For example, select **Language** to change the menu language.
5. Enable **Broadcast Keys** in the *Communications* menu – this lets you to switch between communicating with one or all projectors when connected serially.
6. Select **Auto Setup** to automatically select the best settings for an incoming signal.
7. Make sure that **Processing Mode**, in *Image Settings*, is correct for the selected source.
8. Change **Resize Presets** if you want the image displayed at a resolution other than native.
9. Adjust **Pixel Phase** and **Pixel Tracking** from the *Size and Position* menu to eliminate noise from the displayed image.
10. Adjust **H-Position** and **V-Position** from the *Size and Position* menu to re-center the image on screen.
11. Adjust **Size** in *Size and Position* until the image is at the necessary width, then adjust **Vertical Stretch**. Adjusting one option may have an affect on the other; repeat adjustment if necessary. Adjust H-Position and V-Position again if required to center the image.
12. Adjust the geometry. Use **Table 2.7** as a guide.

**Table 2.7 Recommended Order for Image Setup**

Flat, Straight-forward Alignment (Use the options available in <i>Menu &gt; Configuration &gt; Geometry and Color</i> )	Complex Geometry (Use TWIST software for geometry correction and blending, see the TWIST User Manual)
Geometry Correction	TWIST™ Software - Warping
Edge Blending	TWIST™ Software - Blending
Black Blending	<b>NOTE:</b> Do not use black blending if Twist software is used for geometry correction.
Brightness Uniformity	TWIST™ Software - Brightness Uniformity

13. ArrayLOC automatically adjusts projector colors and brightness. Ensure that arrayLOC is enabled.
14. Some analog sources may require adjustments to **Blacklevels** and **Input Levels**.

## 2.10 System Integration - GPIO Connector

The General Purpose Input-Output (GPIO) connector located on the Mirage WU-L projector input panel is used to enable control of stereo function.

### GPIO and External Devices

If you want to use GPIO to interface external I/O devices to the Mirage WU-L projector, you will need to have a custom adapter made. Seven GPIO pins on the 9-pin D-Sub GPIO connector are configured through RS232 commands. The other two pins are reserved for ground and power. See **GPIO Pins** for pin identification. The cable required for connecting the external device to the projector GPIO connector, whether a standard serial cable or a custom one, must be compatible with the external device.

**Table 2.8 GPIO Pins**

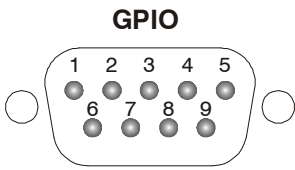
	PIN NUMBER	SIGNAL
	1	+ 12V (200mA)
2	GPIO 1	
3	GPIO 2	
4	GPIO 3	
5	Ground	
6	GPIO 4	
7	GPIO 5	
8	GPIO 6	
9	GPIO 7	

The GPIO connector can be configured to automate any number of events using the serial command code `GPIO`. Each pin is defined as either an *input* or *output* depending on the desired outcome. In general, configure the pin as an input if you want the projector to respond to something the device does and as an output if you want the external device to respond to an action taken by the projector. For example, configure the pin as an output if you want the lighting in a room to automatically dim when the projector is powered ON. By using the `GPIO` command, you can also set the state of each pin as *high* or *low*. By default, the state of each pin is *high*. The voltage applied to pins in the *high* state is + 3.3V. See [\(GPIO\) General Purpose Input/Output, on page D-29](#).

## 2.11 Projection Lenses, Lens Mount and Other Features

**⚠ CAUTION** Using the lens cap when transporting the lens avoids scratching and damaging the lens.

The Mirage WU-L projector includes a lens mount that allows lens control and adjustment: vertical and horizontal offsets, zoom and focus. The lens mount can be fitted with any one of the available optional lenses – see [Section 7 Specifications](#).

- **Zoom and Focus** – Adjust zoom to fit the displayed image on the screen and adjust focus to improve the clarity of the image.
- **Lens Offset** – The lens mount allows vertical and horizontal offset of the displayed image.
- **Shutter** – Standard on all models, the shutter allows you to turn the screen absolutely black when in the “Closed” state. A WHITE shutter state allows you to view menus and images if RGB brightness is set to 0.

## 2.12 Cleaning the Lens

Check periodically. A small amount of dust or dirt on the lens has minimal effect on image quality. To avoid the risk of scratching the lens, **clean only if absolutely necessary.**

Dust:

1. Brush most of the dust from the lens with a camel-hair brush or blow dust away with a dust-free blower.
2. Fold a microfibre cloth smooth and gently wipe remaining dust particles from the lens. Wipe evenly with the smooth portion of the cloth that has no folds or creases. **DO NOT** apply pressure with your fingers - use the tension in the folded cloth itself to collect dust.
3. If significant dust is still bound to the surface, dampen a clean microfibre cloth with coated optics cleaning solution (damp, not dripping). Wipe gently until clean.

Fingerprints, smudges, or oil:

1. Brush away most of the dust with a camel-hair brush and/or blow away using a dust-free blower.
2. Roll a lens tissue around a swab and soak it in coated optics cleaning solution. The tissue should be damp, but not dripping.
3. Gently wipe the surface using a figure-8 motion. Repeat this motion until the blemish is removed.



# 3 Operation

**⚠ WARNING** See Safety Warnings and Guidelines in 5 Maintenance.

This section describes the controls and switches used for basic projector operation once it is properly installed, aligned and configured by a Christie accredited service technician. You can access projector controls and settings with the IR remote, or with a laptop using the web interface. This chapter focuses on the use of the IR remote, and the projector menus. For information about accessing the same functionality through the web interface, see [Appendix B: Web User Interface](#).

## 3.1 Using the IR Remote

**⚠ WARNING** Laser radiation is emitted from the laser diode in the remote. Do not look directly into the beam of the laser.

The standard IR remote can be used as a wired or wireless control. Under optimal conditions, the wireless keypad can communicate with a projector over a 100 foot distance. In wireless mode, the standard IR remote communicates with the projector with a battery-powered infrared (IR) transmitter.

Use the standard IR remote the same way you would use a remote control supplied with a TV or DVD player. When pressing a function key, direct the standard IR remote toward the projector's front IR sensor. The IR sensor on the projector will detect the signal and relay the commands for internal processing. A laser pointer is built into the standard IR remote.

Keep these guidelines in mind:

- Press keys one-at-a-time; there are no simultaneous key combinations required.
- **NOTE:** *To use Power, Shutter, and OSD functions, press the appropriate button and then press the UP arrow to switch ON or the DOWN arrow to switch OFF. You can also press-and-hold the appropriate button for 2 seconds, or press it twice quickly.*
- Arrow keys are held down for continuous adjustment/movement in the related key direction.
- **NOTE:** *In serial networks, pause briefly between adjustments to make sure that more distant projectors can "keep up" with the commands. If you press a key while the projector is still responding to the previous action, such as during power-up, the second key press may not take effect.*
- See [3.1.1 IR Remote, on page 3-2](#) for the description of those keys provided for the standard IR remote keypad.

### 3.1.1 IR Remote

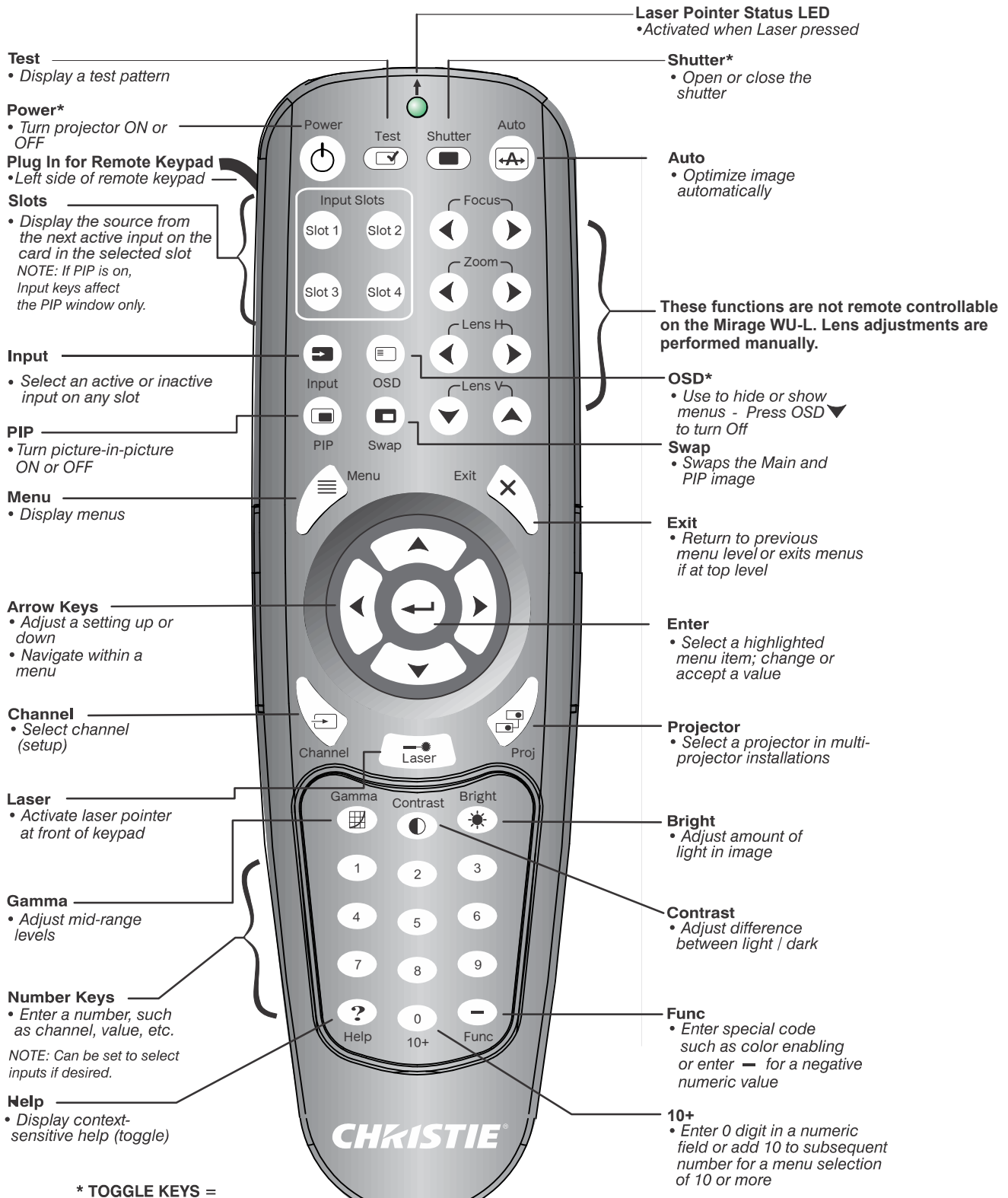

**\* TOGGLE KEYS =**  
 Press and hold to toggle or press twice to toggle or press and release, followed by ▲ON or ▼OFF



### 3.1.2 Wired Remote

You can convert the standard IR remote into a wired remote using the optional cable. Connect one end into the standard IR remote, and the other to the XLR connector labeled `Remote` on the Electronics Module. The wired remote is recommended when the lighting conditions are unsuitable for proper IR transmission.

To use the wired remote, make sure that wired remote support is enabled on the projector the remote is connected to: **Main Menu > Configuration > Communications > Wired Keypad Enabled.**

To use the wired remote to control multiple projectors in an ArrayLOC network, ensure that wired remote support is enabled on the controlling projector, and make sure that key synchronization is enabled on the controlling projector and on all the receiving projectors: **Main Menu > Configuration > ArrayLOC > ArrayLOC Configuration > Synchronize Keys, Test Pattern, Color Enable.**

**NOTE:** *A wired remote control does not require batteries unless you need to use the laser pointer.*

### 3.1.3 IR Remote Commands

Specific keypad commands are explained in [3.1.1 IR Remote, on page 3-2](#).

**⚠ CAUTION**

**The projector is a class 2M source of visible and invisible LED radiation. Directly viewing the LED output with certain optical instruments (for example, eye loupes, magnifiers and microscopes) within a distance of 100 mm may pose an eye hazard.**

#### Power ON/OFF

Press and hold POWER for 2 seconds or press twice quickly to turn the projector ON or OFF. Or, press and release POWER followed immediately by pressing the UP arrow key (ON) or DOWN arrow key (OFF) to guarantee the correct action. This is useful if you are unsure of the present state of the projector.

#### Test

Steps forward through all internal test patterns. After stepping past the last test pattern, you will return to the current input. Press TEST and then cycle by pressing the LEFT or RIGHT arrow keys to cycle in either direction through the test patterns. Press EXIT to return to the current input.

#### Auto

Initiates an automated process in which the projector optimizes critical display parameters such as size, position, pixel tracking, etc., for the current source. These parameters are listed in **Table 3.1**. An Auto Setup can save time in perfecting a display, before you make adjustments as required.

**Table 3.1 Auto Setup**

OPTIMIZES	SETS TO DEFAULT
Pixel Tracking	Contrast
Pixel Phase	Brightness
Size and Blanking	Auto Input Level (OFF)
Vertical Stretch	Detail ( <i>if video source</i> )
Position	Filter
Input Levels	Luma Delay

**NOTE:** *You must have an unlocked channel present to use Auto Setup.*

The *Best Auto Setup* will be obtained under the following conditions:

- **Input levels:** It is best to have an image with saturated (very bright) colors.
- **Phase:** High contrast edges are needed.

To determine the active window size:

- Video images should have whites and blacks in the image.
- Wide range video images should have content (including white) that extends to all edges of the image.

### Channel

Select a specific source setup (channel) defined and stored in projector memory. To select a channel, press CHANNEL and enter a 2-digit channel number; or if there is a list displayed, highlight the desired channel number, and press ENTER. The display automatically changes and updates according to the setup parameters defined for that channel. For more information, see [3.3 Using Inputs and Channels](#).

**NOTES: 1)** *A new channel is automatically created when you adjust an image from a new source. 2)* CHANNEL key behavior during a presentation depends on whether the Display Channel List option is enabled in **Menu Preferences**. You can use a scrollable list of channels when you press CHANNEL, or you can enter the channel number without on-screen feedback. For more information, see [Menu Preferences on page 3-31](#).

### Slot 1, 2, 3, and 4

Press a SLOT key to select the input card in that slot. Press the SLOT key again to display the next active INPUT on the card. Press a different SLOT key to select a different input card. For more information, see [Using Inputs and Channels on page 3-10](#).

### Input

Displays all inputs in all slots, both active and inactive. Press INPUT once and scroll through the list to select an input for the main image. Press INPUT again and select the secondary image. For more information, see [Using Inputs and Channels on page 3-10](#).

### Swap

Swaps between the main and secondary images.

### Contrast

Changes the level of peak white in your images. Use the LEFT/RIGHT arrow key until you reach the desired level of contrast. For best results, start low and increase, so that whites remain bright, but are not distorted or tinted and light areas do not become fully white (i.e., “crushed”). Conversely, low contrast causes dim images.

### Bright

Increases or decreases the black level in the image. Use the LEFT/RIGHT arrow key until you reach the desired level of brightness. For best results, start high and decrease so that dark areas do not become fully black (i.e., “crushed”). Conversely, overly high brightness changes black to dark gray, causing washed-out images.

### Gamma

Determines how gray shades are displayed between minimum input (black) and maximum input (white) for a given amount of signal. The proper setting helps maintain optimized blacks and whites while ensuring a smooth transition for the values used in grays. Unlike brightness and contrast controls, the overall tone of an image can be lightened or darkened without changing the 2 extremes and your images will be more vibrant yet with good detail in dark areas when using the Gamma control. The nominal setting for Gamma Correction of 0 is correct for most signals and conditions. If excess ambient light washes out the image and it becomes difficult or impossible to see details in dark areas, increase the gamma correction setting to compensate.

## Number Keys

Press 1 to 9 to enter a value in a text box or to select a menu item.

To enter a number greater than 9, press 0 (zero) before pressing another number. For example, press 0 (zero) then 2 to enter the number 12 as a menu selection.

**NOTE:** *When entering numbers in a text field, the 0 (zero) button acts as the number 0 (zero). See [Editing Text on page 3-9](#).*

## Help

Press HELP to display a list of context-sensitive *Help* windows. Press HELP again to close the *Help* window.

## Menu

Press MENU to enter or exit the projector menu system.

## OSD (On-screen display)

Press OSD then the DOWN arrow to hide the projector menu system during use.

To see the menus again, do one of the following:

- Press and hold OSD for 2 seconds.
- Press and release OSD followed immediately by UP arrow.
- Press OSD **twice**.

Invisible menus are fully functional, enabling “hidden” access to numbered features and image adjustments by entering the corresponding sequence of key presses on the remote.

**NOTE:** *With OSD ON, you can still hide error messages and slidebars by disabling these options in the Menu Preferences menu.*

## Shutter

The shutter is open upon power-up. Press and hold SHUTTER to move between simulated shutter states in the order: OPEN-CLOSED-WHITE-OPEN. Or, press and release SHUTTER followed immediately by UP arrow (CLOSED) or DOWN arrow (OPEN) to guarantee the correct state.

Close the shutter to block the displayed image while maintaining access to projector functions.

The *white* shutter state allows you to view menus and images if RGB brightness is set to 0. The LED status display shows SH when the shutter is in either black or white modes.

## Function Key

**In a Numeric Field in a Menu:** Use FUNC to enter a negative number.

**In a Text Field:**

- Press FUNC followed by the UP arrow key or DOWN arrow key to convert between Capital and lowercase letters.
- Press FUNC followed by the LEFT or RIGHT arrow key to insert or delete a character respectively.
- Press FUNC followed by ENTER to delete all characters.

**Within a Presentation:** Press FUNC followed by 2 numbers to enable a specific color or colors in the display (see **Figure 3-1**).

For example, will display only red, and will display green data. Eliminating one or more colors can help with certain diagnostics and setups, such as when accurately overlaying one image on top of another from stacked projectors.

**NOTE:** Color enabling can also be implemented from numerous locations within the menu system.

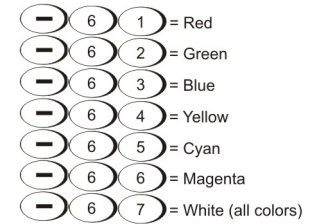

Figure 3-1 Function Key

Press FUNC followed by HELP to disable **Keystone**, **Edge Blending** and **Brightness Uniformity** settings. This disables the features without changing the settings associated with them.

**Proj**

Press PROJ to access a specific projector within a group of projectors or to confirm if the local projector is listening. The number in the **Enter Number** window indicates which projector is currently listening to commands, and will match the projector address defined in the **Configuration > Communications** menu. The **Proj** check box (read-only) shows whether or not the projector physically connected to a remote is listening to commands from that remote. A check mark means that the connected projector is listening; if there is no check mark, you are communicating with a different projector. To control a specific projector with the remote, press PROJ, and then enter the 3-digit number assigned to the projector you want to use. If you switch to a projector other than the one you are currently using, the check mark will disappear. To broadcast to multiple projectors, press PROJ twice without entering a projector number. Remote commands will then affect all projectors present.

**NOTES:** The projector address can be set in the *Configuration > Communications* menu.

**Enter**

Press ENTER to select a highlighted item, to toggle a check box, or to accept a parameter adjustment and return to the previous menu or image.

**Exit**

Press EXIT to return to the previous level (the previous menu).

**NOTE:** Exit does not save changes within text editing boxes (including number editing of a sidebar value) or within drop-down lists. It acts as a “Cancel” in these cases.

**Arrow Keys**

Use the LEFT/RIGHT arrow key to change a sidebar value or to select a different option within a drop-down list without having to first scroll through options or navigate within a menu, drop-down list, or text box.

**Laser**

Press LASER to activate the laser pointer on the remote. Point the remote at the screen to highlight an area of your presentation. the LASER pointer requires batteries in the wired remote to work.

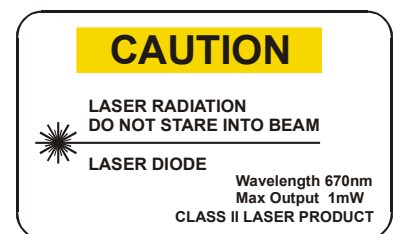

## 3.2 Navigating the Menu

### 3.2.1 Main Menu

Most of the projector controls are accessed from within the projector menu system. There are several groups of related functions, with each group selectable from the **Main Menu**. Press MENU at any time to display the **Main Menu**.

- Using the IR remote, enter the number corresponding to the Function menu you wish to access, such as 2 for the **Image Settings** menu. Or use the UP/DOWN arrow key on any remote to highlight a desired menu option.
- With a Function menu displayed, enter a desired menu option number or use the UP/DOWN arrow key to highlight the desired menu option.
- To select a highlighted menu option, press ENTER. The corresponding function menu or drop-down list showing additional options will display.
- Long menus have a scroll bar on the right. Use the Arrow keys to scroll UP and DOWN through a menu. Locked items or items that do not pertain to the current action or condition appear grayed (**Figure 3-2**), and cannot be selected.

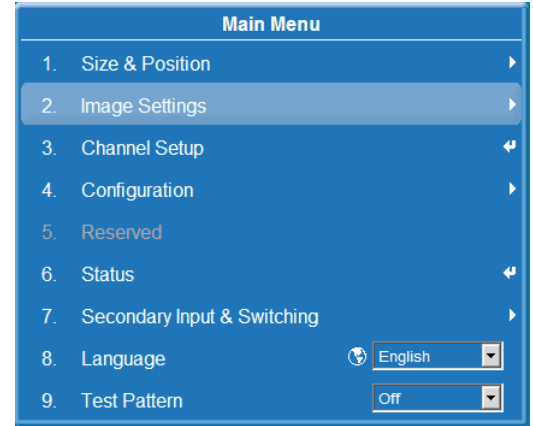

When finished with a function menu:

- Press EXIT to return to the previous screen.

OR

- Press MENU to leave the menu system, and return to the presentation.

**NOTES:** **1)** If there is no signal present, all source-dependent adjustments are disabled. **2)** After 15 minutes of inactivity, the projector closes the menu and returns to the presentation. **3)** The Status menu is read-only.

### 3.2.2 On-line Help

Press the HELP button to display information about the current menu or highlighted option. Press HELP again to exit.

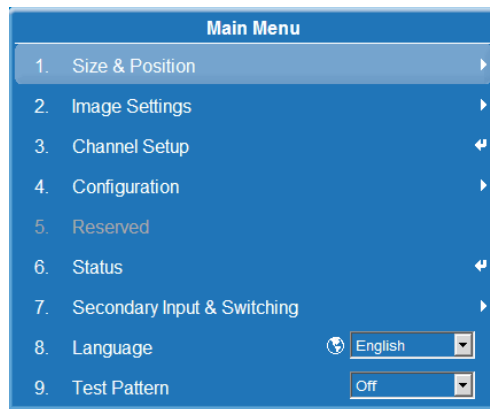

Use this menu to adjust settings affecting current image size and position, such as horizontal and vertical placement, blanking, resizing, and others.

### 3.2.3 The Global Icon



Menu options that include this icon, apply globally. Menu options without this icon apply to the selected channel only.

### 3.2.4 Using Slidebars and Other Controls

Most of the function menus allow you to change settings by using slidebars, check boxes, and drop-down lists. Navigating options:

- Enter the menu option number corresponding to the setting you wish to change (for example, press MENU 1 3 to select **Vertical Stretch** in the **Size and Position** menu).
- Move the highlight to the option desired, and press ENTER.
- Move the highlight to the option desired and press LEFT/RIGHT arrow key to adjust immediately. Both the number and the length of the bar change accordingly. See **Figure 3-2**. Hold for continuous adjustment.
- For options that have their own key, such as **Contrast**, **Brightness**, and **Gamma**, you can bypass the menus entirely and press the corresponding GAMMA, BRIGHTNESS, or CONTRAST key to immediately access an adjustment during your presentation.
- For “blind” access, hide the entire menu system (see *OSD (On-screen display) on page 3-5*) and access using the proper sequence of key presses.



Figure 3-2 Example of a Slidebar

**Slidebars in menus:** The current value for a given parameter, such as size or vertical stretch, appears to the left of its sliderbar icon (adjustment window). This number often expresses a percentage, or it may have units associated with it (such as pixels), depending on the specific option.

- Press LEFT/RIGHT arrow key to gradually adjust the setting up or down.
- Press ENTER to activate a sliderbar text box for specific number entry using the remote.
- When you are finished making your adjustment, press EXIT to save and return to your presentation.
- Some settings automatically impose a test pattern or color change as part of making the adjustment. Pressing EXIT saves the adjustment and automatically cancels the imposed test pattern or color change.

**NOTES: 1)** You can still adjust a sliderbar directly as usual if the display is turned OFF. The sliderbar just won't be visible. (see *OSD (On-screen display) on page 3-5* or *Menu Preferences on page 3-31*). **2)** If you have accessed the sliderbar directly (as described above), it will disappear if it is not used within 5 seconds.

**Check boxes:** A condition is present if an adjacent check box contains a check mark.



Figure 3-3 Example of a Check Box

To select or clear the check box, highlight and press ENTER, or highlight and use the RIGHT arrow key to select (showing a check mark) or LEFT arrow key to clear (showing an empty check box).

If a check box is numbered, enter its number to select or clear the check box. See **Figure 3-3**.

**Drop-down lists:** To see a list of options available for a given parameter:

- Highlight the menu option, and press ENTER.
- Enter the applicable menu option number to open the drop-down list.
- Use the UP arrow key or DOWN arrow key to navigate UP and DOWN within the drop-down list. Press ENTER to choose a highlighted option from the list.
- To quickly scroll through a list without first pulling it down, highlight the menu option, and use the LEFT or RIGHT arrow key. Press ENTER when the desired choice appears.

- Press the LEFT arrow key (backward) or the RIGHT arrow key (forward) to jump between pages in an extra long drop-down list.
- While in a drop-down list, press EXIT to cancel any change.

### 3.2.5 Editing Text

**Activate the Edit Window:** To enter or edit text within a text field, highlight the desired menu option (such as a Channel name) and press ENTER to activate its adjacent edit window. Any previously entered text is displayed with its first character highlighted in a square cursor, signifying that this character is ready for editing.

**Navigate Within the Edit Window:** Press the RIGHT arrow key to move the cursor forward character by character or LEFT arrow key to move the cursor backwards as desired.

**Edit a character:** To edit a highlighted character, use the UP and DOWN arrow keys to scroll through the alphabet (a-z), numbers (0-9), space, and punctuation (- dash or \_ underscore) available. When the character you need is highlighted, press the RIGHT arrow key to select it. The cursor moves to the next available character within the current text field.

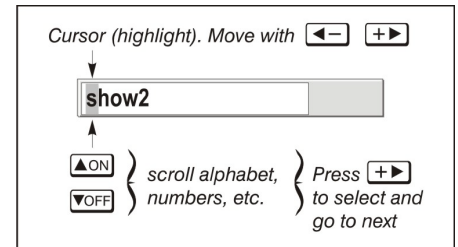

Figure 3-4 Entering Text

**NOTE:** Also enter numbers directly from the IR remote.

**Change Case:** To convert a lowercase letter to a capital letter (uppercase), position on the letter, and press FUNC plus the UP arrow key simultaneously. To convert a capital letter (uppercase) into a lowercase letter, position the cursor on the letter, and press FUNC plus the DOWN arrow key simultaneously.

**Add or Delete a Character or Space:** To insert a space at the cursor position, press FUNC plus the RIGHT arrow key simultaneously. To delete a highlighted character (or space), press the FUNC plus the LEFT arrow key simultaneously.

**Delete all Characters:** Press FUNC followed by ENTER.

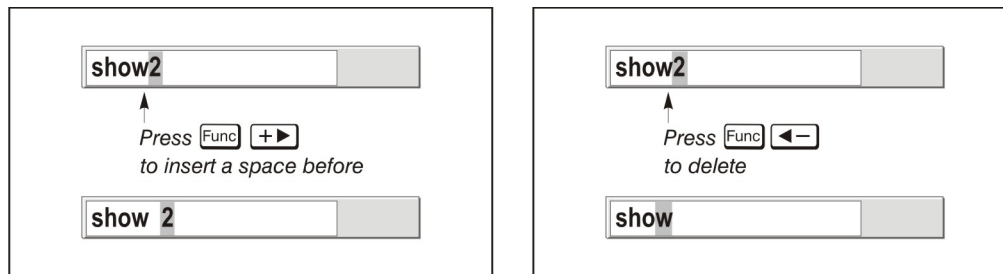

Figure 3-5 Add/Delete Character or Space

**Press Enter When Finished:** To accept (save) all edits and leave the edit window, press ENTER.

**Cancel all Changes and Exit:** Press EXIT at any time to cancel changes, and return to the previously defined (saved) text.

**Edit numerical values:** Enter numbers directly from the remote to specify numbers representing projector channels (source setups), slots, etc. As each digit is entered, it is inserted at the right of the field, and the numbers already in the field are shifted to the left.

Channel numbers are defined with 2 digits, for example, if you enter only a single digit (such as “7”) for a channel number, the channel is automatically redefined as “07”. Enter 07 to use this channel. If you press any non-numbered key, the next sequential number is assigned as the new value. Press EXIT to cancel editing of numerical values.

### 3.3 Using Inputs and Channels

The projector allows you to define, store, and recall up to 99 different channels (customized setups or configurations) for a variety of inputs. Each physical source connection (i.e., input at the projector) can have several different channels associated with it:

- Slot refers to an input card installed in the projector. There are 4 input card slots.
- Input refers to both the physical connector on the input card and to the media source connected to it. Each Input card can have one or more inputs.
- Channel refers to the setup parameters for a media source input. The parameters include the slot and input, input type, and input resolution.

**NOTE:** See 2.3 *Connecting Sources for a full explanation of how to connect sources to the projector.*

#### 3.3.1 Inputs

An input is a input source physically connected to the projector. **Input** describes the source signal and the input slot (1-4) to which it is connected.

##### Switching Inputs

To select an input using the IR remote:

- Press the INPUT key to display the Main Input window, which shows the currently available input signal for each of the 4 input slots. See **Figure 3-8**. The currently selected input for the main image is highlighted. Scroll UP or DOWN through the list. Press ENTER to display the **Input** drop-down list. Scroll through the list to locate the input you require, and press ENTER again to make the selection.
- Press the appropriate SLOT key (1-4) to quickly display one of the 4 inputs connected to the projector for the Main image. Press SLOT again to select a different input. This will not bring up any menu selection, and is only applicable for the Main image.

To select an input using the menu system:

- Use the menu options **Menu > Secondary Input & Switching > Main Input** and **Menu > Secondary Input & Switching > Secondary Input** to select the source of the image for the main or secondary image. Secondary input is not supported in 3D mode.





With any of these methods, the image will be displayed according to the following:

With any of these methods, the image displays according to the following:

- If it is the first time you have used the source/input (or if you used the input, but did not define a channel by adjusting anything), the projector will recognize the new input signal based on its frequencies and polarities, automatically displaying an image according to default settings for that signal. In general, the image from the new source will be as large as possible without losing its aspect ratio. This and other default image settings depend on the incoming source.
- If you used the source once before and changed a display parameter, such as Contrast, V-Position, etc., then a channel was automatically created and still exists in projector memory ([Creating a New Channel on page 3-11](#)). Using one of the input or slot keys will automatically recall this channel—and all its setup parameters—and will update the display accordingly. If more than one channel exists for the input, the image displays according to the setup parameters for the first channel with matching characteristics.

### 3.3.2 Channels

A channel is a collection of measurements, locations, and parameter settings that tailor the display of a signal to your specific needs. Since input source types and applications can vary greatly, you will likely want to adjust and define a wide variety of parameters, such as brightness, contrast, size, etc., in order to customize and optimize the display from or for a particular input source. For example, the display settings you choose for a VCR source may be very different from those you choose for a high-resolution computer source. Once you have adjusted a display parameter, such as pixel tracking or contrast, all current settings are collectively stored in the projector's memory as a unique 2-digit channel, such as 09. You can have numerous distinct channels available for the same input, any of which can be selected by using the CHANNEL key, followed by the 2-digit channel number. Shown in **Figure 3-6** is a sample list of channels available for **Main Channel 03**.

Channel#	Slot Input	Signal Type	Horizontal Frequency	Vertical Frequency
01.	1,1	pDVI	77.14kHz-	p59.94Hz+
02.	1,1	pDVI	77.14kHz-	p59.94Hz+
03.	1,2	p5W	63.98kHz-	p60.02Hz+

i-Interlaced  
p-Progressive

Figure 3-6 Channel List

**NOTE:** The CHANNEL key may display a channel list or not, depending on what you have defined for “Display Channel List” (see [Menu Preferences on page 3-31](#) discussed later in this section).

In order to access channels by using the CHANNEL key on the remote, you must first create the channels. See [Creating a New Channel on page 3-11](#).

#### Creating a New Channel

To use a new source with the projector, a new channel must be created so that the projector will respond to an Input signal from that source. A new channel can be created automatically, or it can be copied from an existing channel and then edited as necessary. See [Copying a Channel on page 3-13](#). When you select a direct input (SLOT 1, SLOT 2, SLOT 3, or SLOT 4), the projector searches for any existing channels that match the input and signal parameters – this only occurs if **Auto Source** is enabled on these channels. If no match to the incoming input signal is found in the currently defined channels, a new channel is temporarily created based on factory-defined defaults for the new type of signal. The channel number assigned is lowest available number from 01-99.

**NOTES:** **1)** An automatic channel will be discarded unless one or more of its parameters are changed, and will not appear in the Channel list. **2)** If 2 channels have the same distinguishing source characteristics except for the reversal of sync connectors (i.e., H-sync and V-sync, are switched), they are still defined as distinct channels. **3)** You cannot define a new channel without an incoming signal.

### Using A Channel

You can normally select a channel from the **Channel Setup** list at any time by pressing the CHANNEL key. If you want to hide a channel from appearing in this list, you must deselect the **In Menu** option (check box) for that channel. See **Figure 3-7**. If you wish to access the channel, press the CHANNEL key and enter its associated number.

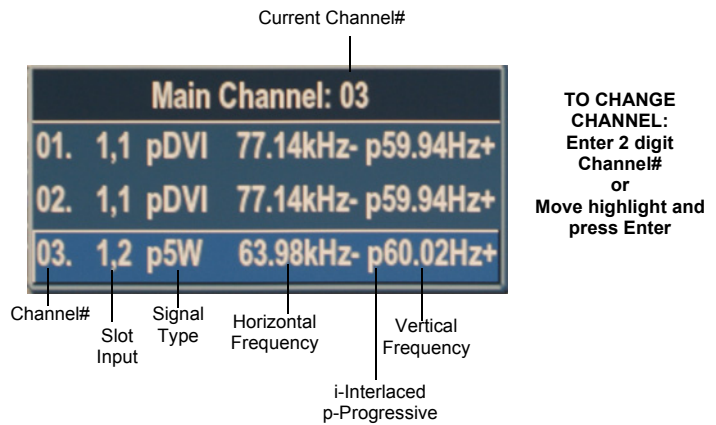

Figure 3-7 Using a Channel

**NOTES:** 1) The current channel is highlighted in the channel list, or, if the current channel is hidden, the first channel in the list is highlighted. 2) Channels created automatically (temporary) do not appear in the channel list unless a parameter for the channel was changed. See [Creating a New Channel on page 3-11](#).

### Channel Setup Menu

All available channels are listed in the **Channel Setup** menu, which describes how each channel can be accessed and provides access for editing, copying, and deleting channels. Press MENU, 3 (Channel Setup). The **Channel Setup** menu displays (see **Figure 3-8**).

The far left column lists channel numbers defined in sequential order, unless you have deleted a channel. See [Deleting a Channel on page 3-14](#). The values in the far right columns indicate:

- Horizontal and vertical frequencies, or if there is a defined name for a channel, appear here. The H & V frequencies will not appear if a name has been defined for the channel; instead the name is only seen. The H & V frequencies are inserted as the name when the channel is first created. The vertical frequency is displayed with the sync polarity.
- The remaining columns pertain to each signal type; input number, slot location, a variety of icons indicating access to each channel, and an abbreviated description of each signal type.
- A **Channel Setup Icon** legend is provided as a reference.

**NOTE:** Use the UP arrow key and DOWN arrow key to see the remaining channels not visible in the initial display of the Channel list.

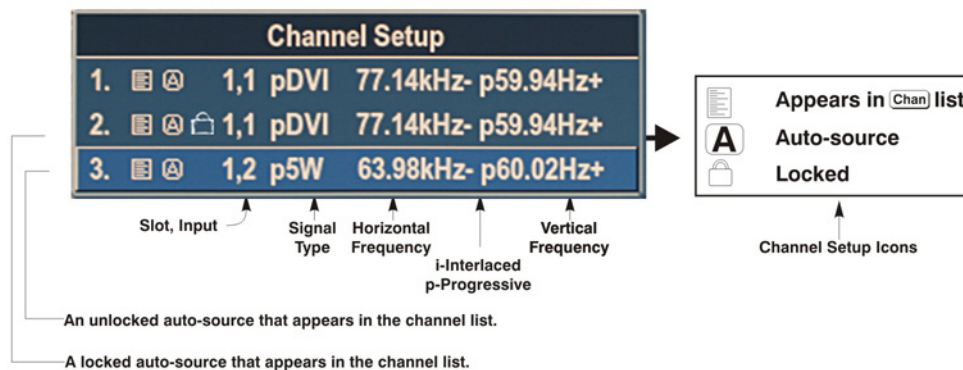

Figure 3-8 Channel Setup Menu

### Signal Type

The **Channel list** or the **Channel Setup** menu identifies the signal type for each channel. The abbreviations are defined in the table below. These abbreviations are preceded by either an ‘i’ (interlaced signals) or ‘p’ (progressive signal).

Abbrev.	Signal Type
--	No Sync
4WH	Composite (4 wire) on HC input
4WV	Composite (4 wire) on V input
SG	Sync-on-green (4 wire)
5W	Separate H,V (5-wire)
5WR	Separate H,V swapped (5-wire)
SVid	S-Video
CVid	Composite Video
Dig	Digital
DSDI	Digital Dual Link HD-SDI
DVI	Digital DVI
HDMI	Digital HDMI
HSDI	Digital HD-SDI
SDI	Digital SDI

The first 5 items in the table are analog RGB with various sync combinations, indicating Sync Source when editing the channel.

### Copying a Channel

Highlight the desired channel in the **Channel Setup** menu, then press ENTER to go to the **Channel Options** submenu. Select **Copy** and press ENTER to create a new channel. It is identical to the original, which still remains, but it is identified with the next available number from 01-99. If you change your mind and do *not* want to copy the current channel, press EXIT to cancel and return to the previous menu.

Copying channels is a quick method for creating numerous channels, each of which can then be edited and adjusted for a variety of presentations in the future.

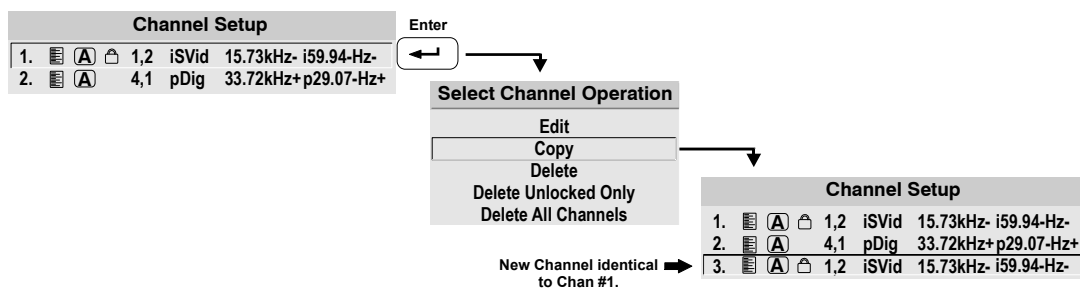

## Deleting a Channel

Highlight the desired channel in the **Channel Setup** menu, then press ENTER to activate the **Select Channel Operation** submenu. Select **Delete**, and press ENTER. A window appears to confirm the deletion of this channel.

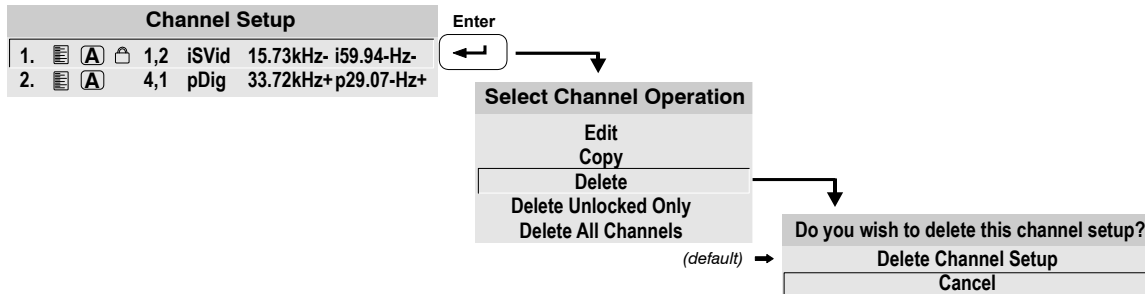

## To Delete Multiple Channels

Highlight any channel in the **Channel Setup** menu and press ENTER to go to the **Select Channel Operation** submenu.

- Select **Delete Unlocked Only** and press ENTER to delete all unlocked channels.
- Select **Delete All Channels** to delete all channels, even those that are locked. In either case, the current channel will remain, but will be redefined from projector defaults.

**NOTE:** For any deletion, a window will appear to confirm the deletion of the desired channel. Select **Cancel** from the menu (default) if you don't want to delete.

## Editing a Channel

1. Press MENU from the presentation level to display the *Main* menu. To display the **Channel Setup** menu, press 3 or move the highlight to the **Channel Setup** option, and press ENTER. The **Channel Setup** menu appears.
2. To edit parameters shown in the **Channel Setup** menu, select the relevant channel and press ENTER. The **Channel Edit** menu will appear similar to the screen capture shown here.
3. Review and edit channel settings as required. See **Table 3.2** for channel setting options.

Channel Edit: 1	
Card Type	Analog BNC Input Card
H-Frequency	15.62 Hz+
V-Frequency	50.00 kHz+
Interlaced	Yes
Sync Source	Sync on Green
1. Name	15.62kHz+ i50.00Hz+
2. Channel	1
3. Slot	3
4. Input	1
5. In Menu	<input checked="" type="checkbox"/>
6. Auto Select	<input checked="" type="checkbox"/>
7. Locked	<input type="checkbox"/>
8. Next Channel	↩
9. Previous Channel	↩

**Table 3.2 Channel Edit Options**

Option	Description
Name	An alphanumeric label can be defined and/or changed here. Channel names can be up to 25 characters in length. The default name is the horizontal and vertical sync frequencies.
Channel	A 2-digit channel number can be changed here. <b>NOTES: 1)</b> <i>If you enter a channel number that already exists, a message appears indicating that this number is already in use; assign a different channel number. 2)</i> <i>You can define up to 99 channels.</i>
Slot	1-4, corresponding to which slot in the projector input panel the source is connected.
Input	1-6, corresponding to which input on the selected slot the source is connected.
In Menu	If checked (default, except for automatically defined channels with unchanged parameters), this defined channel will appear in the list available when CHANNEL key is pressed. If unchecked, the channel must be accessed using CHANNEL on the IR remote or using the <i>Auto Source</i> function. <b>NOTE:</b> <i>On-screen display (OSD) of the channel list is an option in the Menu Preferences menu.</i>
Auto Select	If checked, (default), the projector can automatically locate this channel when an incoming input signal matches. If not checked, the projector is only able to locate the selected channel when it is directly selected using the CHANNEL key on the IR remote. A change in Input signal will not result in a channel change.
Locked	If checked, all of the image settings for this channel are locked. If unchecked (default), all available image settings can be adjusted as desired. You cannot use <i>Auto Setup</i> with a locked channel.
Previous Channel	Select this option to see or change channel settings for the previous channel in the <b>Channel Setup</b> list.
Next Channel	Select this option to see or change channel settings for the next channel in the <b>Channel Setup</b> list.

### 3.4 Adjusting the Image

The most commonly used options for image adjustments are accessed through 2 menus: **Size and Position** (MENU 1) and **Image Settings** (MENU 2), both of which appear in the **Main** menu. You can change settings affecting the image from the current channel by working with the appropriate slide bars, check boxes and drop-down lists from either of these 2 menus. EXIT returns to the previous menu (or to the presentation, if from the **Main** menu) and accepts any changes you may have entered. Settings are saved with the current channel. From your presentation, you can access any of the individual options in these menus by pressing MENU followed by the appropriate number keys representing their location in the menu system. For example, press MENU, 2, 7, 1 to quickly access the “Gamma” option in the **Image Settings** menu.

**NOTES: 1)** *Some frequently used display functions have dedicated keys on the IR remote. For example, press CONTRAST to access the contrast slide bar. Press EXIT to return to your presentation. 2)* *To hide “direct” slide bars, disable the Display Slide bars check box in the Menu Preferences menu. 3)* *To hide the entire menu system from view, turn OFF the on-screen display by pressing OSD then the DOWN Arrow Key.*

### 3.4.1 Automatic Image Setup

Auto setup is a good first step in setting up the image. Press AUTO on the remote. This optimizes critical display parameters such as size, position, pixel tracking, etc., based on the type of incoming source. An auto setup can save considerable setup time, and you can still adjust the image as described below.

The best auto setup will be obtained under the following conditions:

- Input levels: It is best to have an image with saturated (very bright) colors.
- Phase: High contrast edges are needed.

To determine active window size:

- Video images should have whites and blacks in the image
- Wide range video images should have content (including white) that extends to all edges of the image.

### 3.4.2 Size and Position Menu

Increase or decrease the size of your image, change its proportion (aspect ratio), move the image to a specific area of the screen, and refine other related parameters. Use **Size and Position** controls to match the image precisely to the screen used at the site. See [3.2.4 Using Slidebars and Other Controls](#) if you need help using any of the options and controls. Changes made in the **Size and Position** menu are applied immediately and are saved when you exit the menu (press EXIT or MENU).

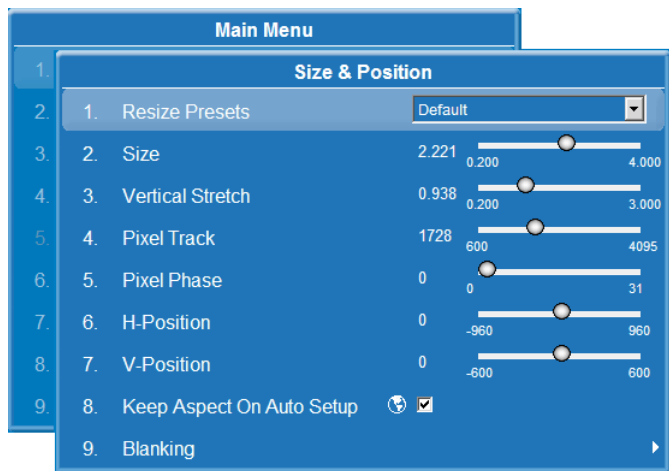

#### Resize Presets

**Resize Presets** will display an image in its native resolution (no resizing) or will resize the image by maximizing either the height, width or both height and width, or will resize to the maximum size possible while keeping the original aspect ratio.

**Size, Position** and **Blanking** parameters will automatically adjust accordingly or, if **Blanking** is set first to define an Active Input Area; **Resize**

**Preset** scaling will occur in this region of interest only.

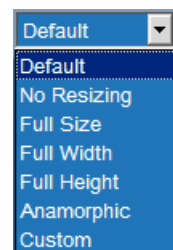

- Maximize for current source
- Display in native resolution
- Fill the screen (regardless of source)
- Fill display width and keep aspect ratio
- Fill display height and keep aspect ratio
- Retain 16:9 aspect ratio

- **Custom** re-size option does not initially appear in the **Resize Presets** drop down list. The **Resize Presets** value changes to Custom automatically when any of the values for *Size*, *Vertical Stretch*, *H-Position*, *V-Position* or *Blanking* do not correspond to those for a preset option.

- Select **Default** for most sources (factory default). The image will be centered and displayed as large as possible depending on the type of source.

By default when displaying a new source, your image will use as much of the projector display area as possible for the type of incoming source data, but with minimal or no changes to aspect ratio.

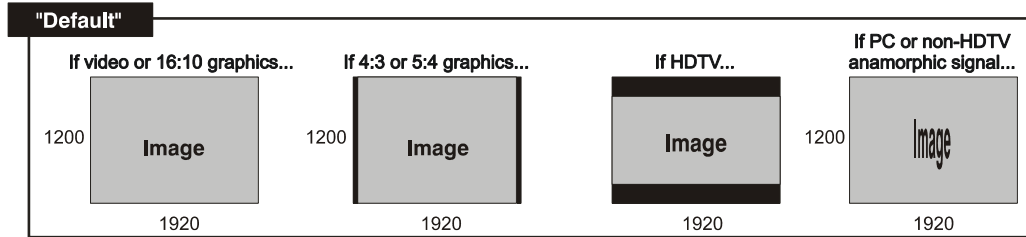

- **No Resizing** displays the image in its native resolution, which may or may not match the projector resolution. For example, for a source with a native resolution of 800 x 600, “No Resizing” in an SXGA+ projector will use the central 800 x 600 pixels, and have a black border. The black border areas are unused areas as shown below.

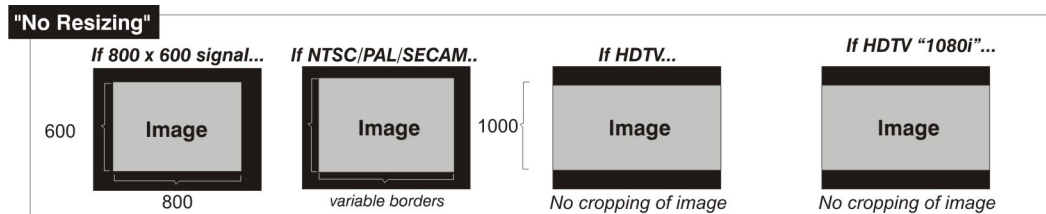

- **Full Size** uses all pixels for displaying the image, regardless of source or original aspect ratio. Incoming source material having a different aspect ratio than the projector will be stretched for display.
- **Full Width** fills the projector display from left-to-right without changing the original aspect ratio of the image. Depending on the source, data at the top and bottom may be discarded (cropped), or the display may have black borders at the top and bottom (called “letterboxed”).

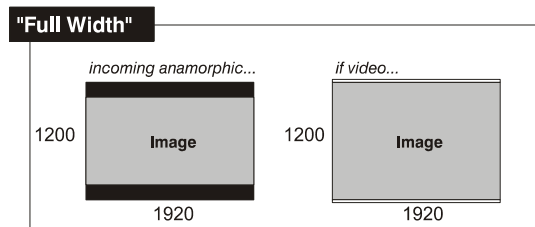

- **Full Width** fills the display from top-to-bottom. Depending on the source, this may create borders.

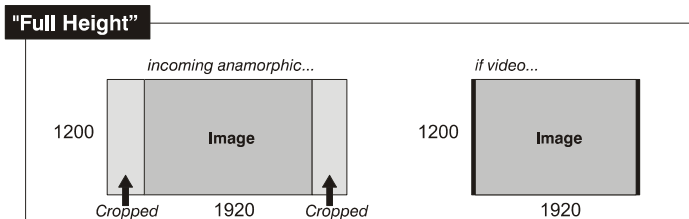

- **Anamorphic** displays an anamorphic image in its native 16:9 aspect ratio. The image will fill the screen from side-to-side and be centered between black bars at top and bottom.

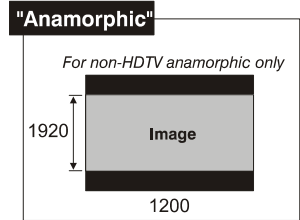

### Size

Controls both the image width and height, maintaining the current aspect ratio of the displayed signal data.

### Vertical Stretch

Adjusts the height of the image while keeping the width constant. Use **Vertical Stretch** to change the aspect ratio of the display.

### Pixel Track

Steady flickering or several soft vertical stripes or bands across the entire image indicates poor pixel tracking. Proper pixel tracking ensures that the image quality is consistent across the screen, the aspect ratio is maintained, and that the pixel phase can be optimized (described in [Pixel Phase on page 3-18](#)). Tracking determines the frequency of the pixel-sampling clock, indicated by the number of incoming pixels per line, so that all pixels generated by a particular source are sampled.

**NOTE:** *By default, the projector samples at the correct frequency for most sources.*

For best results, use a test pattern such as a smooth gray consisting of a clear pattern of black and white pixels, or a similar “half ON, half OFF” graphic image, such as the Windows 2000 shutdown screen. Adjust the slide bar until the vertical stripes broaden to the point where one large stripe fills the image. If the image still exhibits some shimmer or noise, adjust Pixel Phase as described in [Pixel Phase on page 3-18](#).

### Pixel Phase

**Adjust “Pixel Phase” after “Pixel Track”.** Adjust pixel phase when the image (usually from an RGB source) still shows shimmer or “noise” after pixel tracking is optimized. Pixel phase adjusts the phase of the pixel-sampling clock relative to the incoming signal. Adjust the slider until the image stabilizes and each pixel is clearly defined. You may notice that you can stabilize the image at more than one point. For example, you may find that the image appearance at “11” is identical to the image appearance at “38”, you can use either setting. If some shimmer from a video or HDTV source persists, use the “Filter” control to remove high-frequency noise from the signal.

### H-Position

Move the image right or left within the area of available pixels. The value shown represents the approximate center of the image in relation to the total number of horizontal pixels. It varies widely according to the signal; watch the image while adjusting.

### V-Position

Move the image up or down within the area of available pixels. The value shown represents the approximate center of the image in relation to the total number of vertical pixels. It varies widely according to the signal; watch the image while adjusting.

### Keep Aspect on Auto Setup

Maintains the input aspect ratio when calculating the default size in auto setup. If disabled the source is scaled to fit the platform, except where the video source includes a defined default stretch.



**Blanking**

**Active Input Window**

This read-only value indicates the current size of your displayed data or “region of interest” as defined by the blanking controls. By default, the projector automatically determines what portion of its full resolution to use, and pixels in the surrounding borders are turned off. Specify the active input window size by adjusting one or more Blank settings (**Figure 3-10**). For example, if you have blanked (cropped) 100 pixels from both the left and right edges of an incoming source of 1400 x 1050, the remaining active input window will be reduced to 1200 x 1050.

**Blanking (Top, Bottom, Left, and Right)**

Crop the image so that unwanted edges are removed from the display (changed to black). Blanking defines the size of the **Active Input** window, or area of interest. Range of adjustment depends on the source resolution, and other factors.

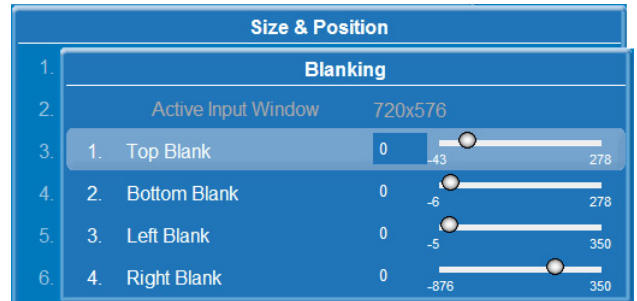

Figure 3-9 Full Width

**3.4.3 Image Settings Menu**

Use the **Image Settings** menu to alter your main image without affecting its size or position. Changes made are applied immediately and are saved when you exit the menu (press EXIT or MENU). Options not available for the projector model or source are disabled, and appear dim (gray).

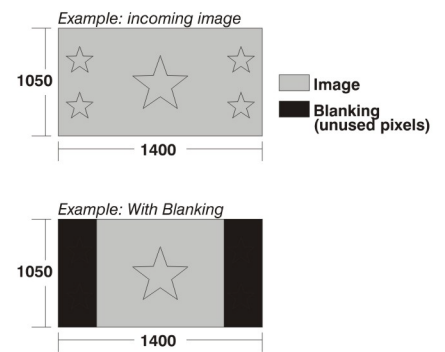

Figure 3-10 Blanking of a Primary Image

Image color is managed by ArrayLOC (see [ArrayLOC Menu on page 3-45](#) and [Managing Colors with ArrayLOC on page 3-55](#)).

**Contrast**

Contrast increases or decreases the perceived difference between light and dark areas of your image (0-100). For best results, keep close to 50. For best results, start with a low value and increase so that whites remain bright, but are not distorted or tinted, and that light areas do not become white.

**NOTE:** *If the environment lighting changes, an adjustment of Gamma is recommended (see below).*

**Brightness**

Increases or decreases the amount of black in the image (0-100). For best results, keep close to 50.

Start with a high value and decrease so that dark areas do not become black. Conversely, high brightness changes black to dark gray, causing washed-out images.

**Reserved**

This selection is reserved for future use.

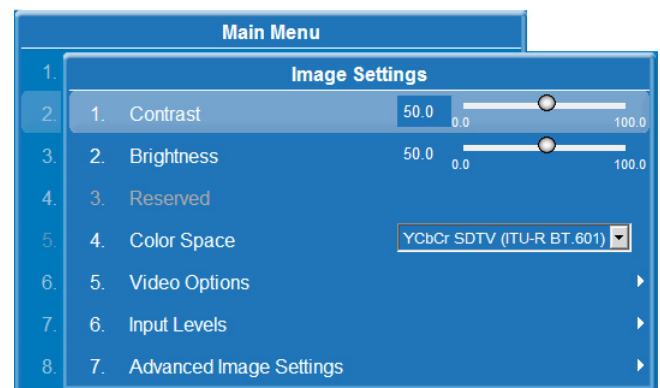

### Color Space

Determines how the color components of an analog input signal are decoded for accurate color in the display. Useful only for analog signals and certain digital sources. Although color space for these analog signals is automatically determined by the projector, you may wish to override this and manually set a specific color space.

**NOTE:** For some signals, the color space function is entirely automatic and the drop-down list is disabled.

The current color space appears in the **Image Settings** menu. Press ENTER to select a different option:

- Select **RGB** unless you are using component video.
- Select **YCbCr SDTV (ITU-R BT.601)** with a standard definition televised signal (SDTV).
- Select **YCbCr HDTV (ITU-R BT.709)** with a high definition televised signal (HDTV).

**NOTE:** When certain RGB signals are first connected, the projector may not recognize them as RGB and will incorrectly decode their color information as YCbCr (video). These signals can include:

- RGB signals in NTSC, PAL, SECAM frequency ranges.
- Scan-doubled sync-on-green.
- Scan-quadrupled sync-on-green.

For these signals, change the color Space to RGB, and then define a new channel for future use.

### Video Options

This submenu is used with video sources only. See [Video Options Menu on page 3-20](#).

### Input Levels

**Only experienced users should use the Input Levels submenu.** With Auto Setup, the projector automatically determines the best input levels by monitoring image content and adjusting the controls appropriately; further adjustment is typically not required to obtain proper blacks or whites. Use this menu to manually adjust blacks and whites. See [Input Levels Menu on page 3-22](#).

### Advanced Imaging Settings

Use the **Advanced Image Settings** submenu to make the adjustments necessary for lesser-used but more specialized applications on your projector. See [Advanced Image Settings Menu on page 3-25](#).

### Video Options Menu

This submenu is used with video sources only.

#### • Enable Decoder AGC

Automatic Gain Control (AGC) affects decoded video images only. Enter a check mark (default) to activate the decoder's AGC circuit to ensure properly bright images. Delete the check mark if a decoded video image exhibits strange color artifacts such as stripes in highly saturated colors, indicating an incompatibility between this source and the AGC.

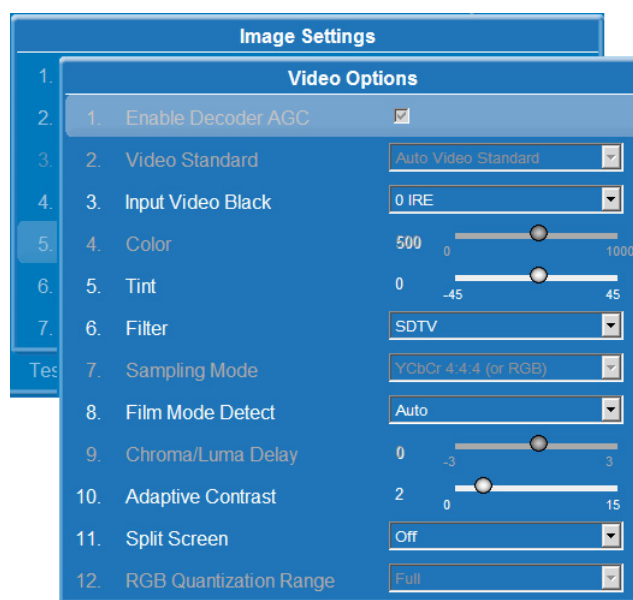

• **Video Standard**

Identifies the standard used to process the video signal. For most sources, the projector automatically detects the incoming horizontal and vertical frequencies and sets the signal processing to the corresponding standard. An “A” indicates auto-selection. Press ENTER to select a different video standard from the list. Standards that have frequency characteristics that differ from those of the incoming signal are disabled.

**NOTE:** Best results are obtained with defined channels. Otherwise, switching from one video source to another can sometimes cause slight disturbances in the display, indicating that the Auto function is struggling. Recover by briefly selecting a different video standard, then going back.

**Table 3.3 Regions and Video Standards: Summary**

STANDARD	WHERE USED (Subject to Change)
PAL	Most of Europe, China, Australia, some of S. America, and some of Africa
NTSC	N. America and Japan
SECAM	France, Eastern Europe, most of Africa
NTSC 4.43	A tape-only standard for partially-translated hybrid signals
PAL-M	Brazil
PAL-NC	Argentina, Chile, other Latin American countries
PAL 60	Most of Europe

**NOTE:** Generally, use “Auto” for all instances except: a poor quality input signal or a black-and-white video signal. In order to detect and display such signals, select the relevant standard from the list.

• **Input Video Black**

This control compensates for incoming elevated black levels present in certain video signals, and ensures that blacks in the display are neither crushed (i.e., where dark grays appear black) nor excessively elevated (i.e., where blacks appear dark gray). By default, the projector automatically determines the best setting according to the type of incoming video signal:

If grays are black, select ➡ **1. 0 IRE**  
 If blacks are gray, select ➡ **2. 7.5 IRE**

- **0 IRE** – Used for DVD output with “enhanced black”, SECAM, most PAL standards, and Japanese NTSC.
- **7.5 IRE** – Used for most NTSC video signals.

For some types of video, you can override the setting. The control is disabled for other types of video (and all graphics sources). Generally, if black appears crushed when brightness = 50, choose “0 IRE”. If black appears excessively elevated, use “7.5 IRE”.

• **Color**

This slide bar adjusts the color saturation level. Lower settings produce less saturated colors, for example a setting of “0” produces a black and white image. If the color level is too high, colors will be overpowering and unrealistic.

• **Tint**

Adjusts the red/green color hue for true color reproduction of video and HDTV signals. For best results, adjust tint while displaying an external test pattern. It is recommended that tint remain at its default setting.

- **Filter**

The proper filter setting is automatically set for virtually all signals, and rarely needs to be changed. Override only if standard pixel tracking and phase adjustments do not adequately clear up a “noisy” video signal, or if a graphics signal appears overly “soft”. Both instances indicate that “Filter” may be set to the wrong option.

- **Sampling Mode**

Sets the color sampling mode for a digital signal to either YCbCr 4:4:4, RGB or YCbCr 4:2:2. The proper sampling mode is determined automatically by the projector; you can override this setting.

- **Film Mode Detect**

Enable or disable film motion detection. Only available for interlaced or segmented frame sources.

- **Chroma/Luma Delay**

Affects any incoming composite or S-video signal, delaying the luma signal (intensity) in relation to the chroma (color). In the image, increasing the luma delay will move luma (seen as a shadow where colors overlap) to the right slightly, with colors remaining in place. Decreasing this delay will move the shadow slightly to the left. If necessary for your current source, adjust so that no shadows occur with adjacent colors.

- **Adaptive Contrast**

Dynamically expands the contrast of the output image producing vibrant images with seamless response to scene changes and fades. The slide bar adjusts the amount of adaptive contrast to apply, with a setting of “0” producing no change.

- **Split Screen**

This control allows a snap shot of the main image to be presented on the right side or lower part of the screen, to allow evaluation of advanced image processing features. All resizing controls are honoured on both images. However, image processing controls (such as, *Detail*, *Sharpness*, *Noise Reduction* and *Adaptive Contrast*) only happen on the left side or top image. Changing inputs, channels or test patterns will disable this control.

- **RGB Quantization Range**

This control defines the RGB quantization levels for digital DVI and HDMI inputs using the RGB color space. Typically, graphics sources use the full range of levels for the given bit depth (i.e. 8-bit, 10-bit, 12-bit) and consumer electronics (CE) products typically use a limited range of data within the given bit depth. This control must be set to *Limited* to correct the levels for those CE products that use the limited space. This adjusts what is considered black and white levels in the image. As an example for 8 bit space, full range RGB uses levels 0 (black) to 255 (white). A limited CE range is 16-235 for 8-bit video sources.

### Input Levels Menu

**Only experienced users should use the Input Levels submenu.** The projector automatically optimizes input levels for all but the most unusual of sources. Before starting, check that overall contrast and brightness settings are near 50 and that color temperature is properly set up on an internal grayscale test pattern. Good RGB or input levels (that is, the *drives* and *black levels* for each of the 3 colors, red, green and blue) ensure that images from analog sources other than decoded



Turn OFF before leaving menu.

Levels adjust automatically and correctly.

video have maximum contrast without crushing black or white. By default (and in an “Auto Setup”), the projector automatically determines the best input levels by monitoring image content and adjusting the controls appropriately; further adjustment is typically not required to obtain proper blacks or whites.

**NOTE:** *This automatic adjustment requires at least 6-12 consecutive white pixels in the image. Without these pixels, input levels may produce skewed colors, particularly in non-video images.*

For a source exhibiting overly high black levels (typically caused by a noisy source causing black level spikes) use the **Input Levels** menu (3.3.1 Inputs, on page 3-10). These adjustments, serve as a calibration process compensating for differences in sources and cabling, to perfect the source image input levels and eliminate “overshoot” and “undershoot”.

**NOTES:** **1)** *Input Levels are of limited use with digital signals, but do offer some ability to tweak poorly-mastered source materials. **2)** Input levels apply for the current source only, but for any color temperature used. **3)** Assuming that color temperature has been set up based on the internal test patterns, you can then set up input levels for a given source so that it matches the color temperature of the internal test patterns.*

• **Auto Input Level**

Use only if you are an experienced user and you have an unusual source that you feel needs further Color Temperature and/or Input Level adjustment. This compensates for incoming out-of-range drives (white) and black levels (black) that would cause “crushing” of light and dark colors in the image. After entering a check mark, wait for the 6 slide bar values to stabilize, then delete the check mark, and exit. The **Auto Input Level** is automatically turned OFF upon exit from the **Input Levels** menu.

• **Black Levels and Drives**

**NOTICE:** *Do not use Input Levels to adjust color temperature. This will distort contrast and brightness functions, as well as color temperature.*

To check your image levels and adjust these controls:

1. Confirm that you are using an input on a Dual Link DVI card. Input Levels are not applicable for sources going through the decoder.
2. Display a representative image for source you are setting up.
3. Make sure that overall “Contrast” and “Brightness” settings are both set to near 50.
4. If black levels are too high (or whites are too low, which is rare), you likely have a noisy source that is producing skewed input levels.
5. To adjust levels automatically, check to enable **Auto Input Levels** in the **Input Levels** menu. Wait for all six **Blacklevel** and **Input Drive** values to stabilize. Uncheck the **Auto Input Levels** option.

**NOTE:** *Do not use Auto Input Levels for dark images.*

6. Exit the **Input Levels** menu. Exiting the Input Levels menu automatically disables **Auto Input Levels** and **Auto Color Enable**.

• **Auto Color Enable**

When a check mark is present, select a specific black level or drive will automatically enable the corresponding color in the display. Delete the check mark to see all colors, or to enable a different specific color through the **Color Enable** control.

- **Clamp Location**

Clamp Location brightens the image produced from certain high-resolution high-frequency graphic sources. The projector automatically selects the best clamp location for most sources. Use the normal **Back Porch** location if the image is either sufficiently bright or overly bright. Select **Sync Tip** if the image appears unusually dim, if there are horizontal streaks across the image, or if there is significant color drift. This moves the clamping pulse from the normal back porch location (which is likely too short) to the tip of the horizontal sync pulse. **Tri Level** is typically needed for an HDTV source.

- **Input Peak Detector**

Input Peak Detector is a tool to assist with defining individual input levels, enabling you to accurately set the input levels for any particular source with the appropriate image. Enabling the peak detector activates a special operating mode for detecting *only* pixels that are considered black or white. All other levels are displayed as a mid-level gray. When used with a smooth grayscale pattern in which black and white are known to be at opposite edges of the image, you can watch these isolated areas while adjusting individual black levels and input drives until both black and white edges are *just* visible and distinguished from neighboring pixels. Images from this source will then display correct blacks and whites without crushing.

To adjust levels manually:

- Do not enable Auto Input Levels.
  - To judge by eye and adjust levels manually, change one or more of the six levels as necessary to obtain proper blacks and whites.
1. Display a 16-level grayscale test pattern from the desired external source, and enter a check mark in the **Input Peak Detector** check box.

**NOTE:** *The Input Peak Detector will initially render the grayscale as a uniform gray field before adjustment or extreme crushing.*

2. Display one primary color.

**NOTE:** *Select Auto Color Enable to ensure that the correct color is displayed for each setting.*

3. For the current color, adjust its corresponding **Black level** slider just until a single band of black appears at one edge of the screen. This band represents the first band of the grayscale pattern. It should be 100% black.
4. With the same color still active, adjust its corresponding **Input Drive** slider *just* until a single band of color appears at the opposite edge of the screen. This band represents the last band of the grayscale pattern, which should be 100% white (or the current color, if a certain color is enabled).
5. Check the black band and adjust the black level slider, if necessary.

**NOTE:** *Adjusting the black levels affects the gain. Only adjust when necessary.*

- Repeat steps 3-5 with the 2 remaining primary colors. When each primary color shows one optimized black band and white (or colored) band, the Input levels for this source are correctly set. Upon exiting the **Input Levels** menu, the **Peak Detector** check box will clear.

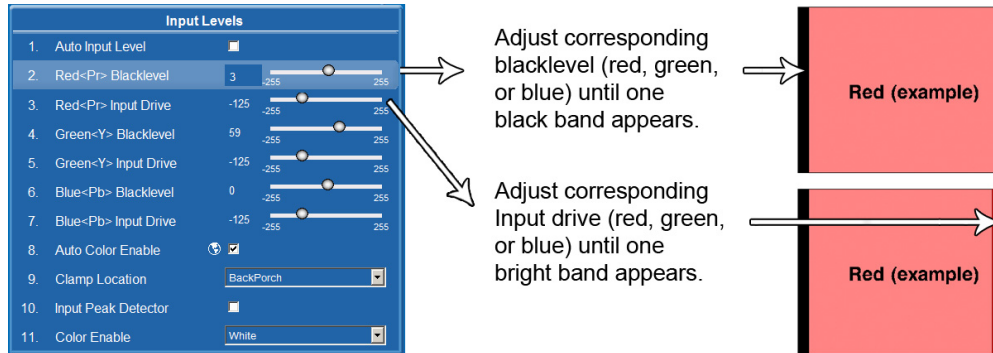

Figure 3-11 Adjusting Input Levels Using the Peak Detector

Select which color or colors you want to see in the display, useful while working with color temperature white levels or input levels.

**NOTES:** **1)** Input levels apply for the current source only, but for any color temperature used. **2)** If color temperature is set up based on the internal test patterns, you can set up input levels for a given source so that it matches the color temperature of the internal test patterns.

### Advanced Image Settings Menu

Use the **Advanced Image Settings** submenu to make the adjustments necessary for lesser-used but more specialized applications on your projector.

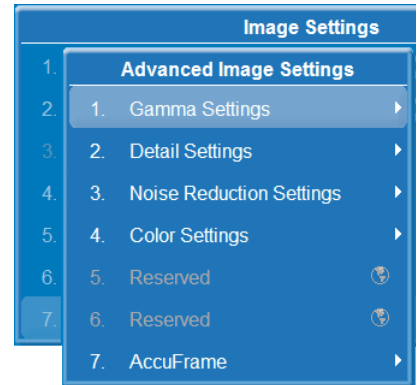

### Gamma Settings

The system offers 2 types of gamma correction. Gamma correction can be applied to a specific source to correct for luma encoding. This is a channel setting and reapplied every time the same signal is detected. This is the 'Gamma' control. On the other hand the system also provides a global **Gamma Correction** control. The global control offers an offset applied to all channels. This offset is used to compensate for changes in ambient conditions, such as ambient light in the room and projected material.

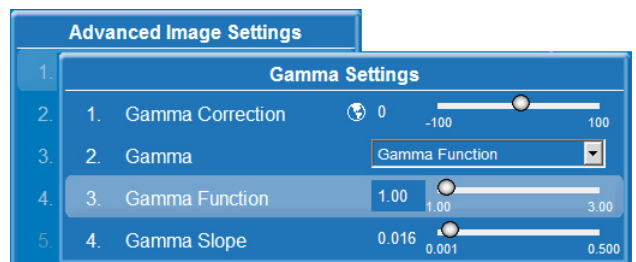

- **Gamma Correction**

Applies a global offset to all gamma settings for each channel. It affects the shape of the curve by performing a linear transform toward a gamma curve of 1.0 while the control is increasing and likewise a linear transform toward a gamma of 3.0 as the control is decreasing. The control should only be adjusted to compensate for ambient conditions. To correct a particular source only, use the **Gamma** control.

- **Gamma**

Select the base gamma table for a given source. Select from one of the standard tables, a custom gamma function, or select an arbitrary gamma table that has been downloaded to the projector.

**NOTE:** A separate PC utility is needed to do this.

The 2.22 curve is a power curve typically used to encode graphics and video sources, see **Figure 3-12**. The 'standard' curve (auto setup default) is a modified 2.22 curve with a small linear section in the black that enhances the detail in darker areas of the projected content. Typically standard or 2.22 is used for all sources. Alternatively, if neither default is ideal, apply a simple gamma curve by defining a custom power function and slope. Select **Gamma Function** to enable the function and slope controls. For more complex non-standard gamma curves, a user-defined curve created externally and downloaded to the projector can be used (requires separate PC-based Arbitrary Gamma software application to create the table, and the Web UI to download it).

**NOTE:** If any of these special user curves have been installed, their names will appear in the Gamma Table drop-down list.

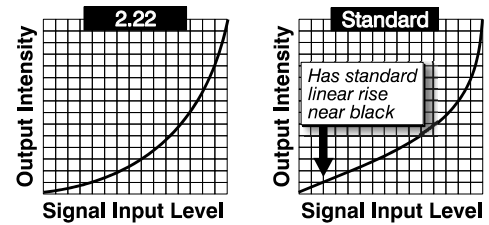

Figure 3-12 Gamma Curve

- **Gamma Function**

Defines the base gamma power curve used when the base Gamma table value is set to “Gamma Function”. This value, combined with the Gamma Slope setting determines the base Gamma table to be used as the custom base table. The curve is generally a power curve with a small linear segment at the bottom defined by the slope.

- **Gamma Slope**

This control defines a slope to be used for the base custom Gamma table for a small section at the bottom of the curve. This slope can be used to bring in or out the low level blacks in the image. This slope, combined with the gamma function, defines the custom Gamma table.

**Detail Settings**

Adjusts the sharpness of the image. Setting detail above the halfway point can introduce ‘noise’ in the image. Lower settings can improve a noisy signal.

- **Detail**

Adjust the sharpness of the image. Setting detail above the halfway-point can introduce noise in the image. Lower settings can improve a noisy signal. This command does not take effect unless the minimum change required in the **Detail Threshold** control is reached.

- **Texture Enhancement**

Applies texture detail enhancement based on adaptive horizontal, vertical, and diagonal large edge and small edge enhancement processes.

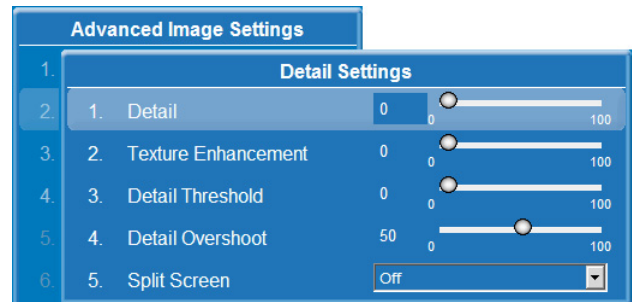



- **Detail Threshold**

Selects a filter sensitivity to noise. A higher value may improve noisy sources especially for higher settings of detail.

- **Detail Overshoot**

Minimizes ringing on the enhanced edges detail and texture effects.

- **Split Screen**

Allows a snap shot of the main image to be presented on the right side of the screen to allow evaluation of advanced image processing features. All resizing controls are honoured on both images; however, image processing controls only happen on the left side image. Changing inputs, channels or test patterns will disable this control.

**Noise Reduction Settings**

- **Noise Reduction**

Selects a filter sensitivity to noise. A higher value may improve noisy sources, but it will soften the image.

- **Block Artifact Reduction**

Locates and reduces block edges produced by Discrete Cosine Transform (DCT) based compression processing.

- **Mosquito Noise Reduction**

Reduces mosquito artifacts around sharp edges in DCT based compression by dynamically adapting to image content.

- **Split Screen**

Allows a snap shot of the main image to be presented on the right side of the screen to allow evaluation of advanced image processing features. All resizing controls are honoured on both images; however, image processing controls only happen on the left side image. Changing inputs, channels or test patterns will disable this control.

- **Full Screen Eye-Motion Filter**

Check this control to apply the eye-motion filter to the entire screen rather than applying just to the edge blending regions.

- **Eye-Motion filter**

Adjust this filter to reduce the saccadic eye-motion sometimes noticeable in edge blending regions. Too much filtering may result in loss of detail. For best results, adjust this setting while positioned at the nominal screen-viewing distance.

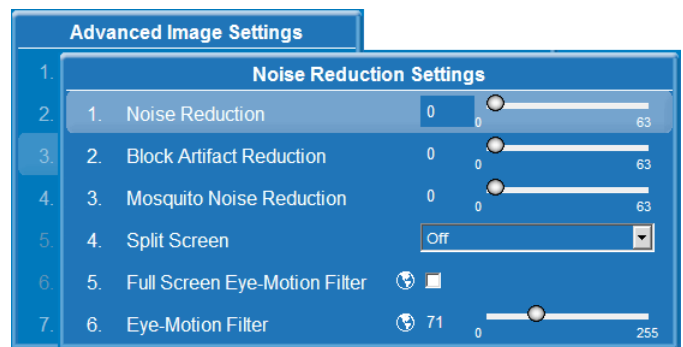

**Color Settings**

**NOTICE:** Use this Color Settings menu to set up color manually only if you override ArrayLOC. See 3.5 How Color Settings Interact in a Mirage WU-L Array, on page 3-61.

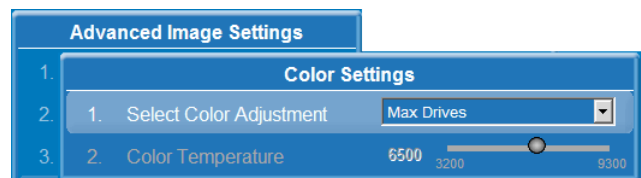

ArrayLOC is enabled automatically, and **Select Color Adjustment** is set to *Max Drives*. Use the color function under ArrayLOC to manage projector color. ArrayLOC color and color temperature settings override settings in this menu.

**NOTE:** *To check ArrayLOC operational status, check Main Menu > Status. ArrayLOC can only be disabled from the passcode-protected Service menu. Please contact Customer Support for more information.*

- **Select Color Adjustment**

Select the output color adjustment most suited to this input signal.

- **Max Drives:** All color adjustments are turned OFF allowing the projector to run at maximum brightness.
- **SD Video and HD Video:** Sets the output color to a specific standard value. Adjusts the colors; red, green, blue, and white.
- **User#:** Select 1 of 4 user defined sets of color adjustments; defined in the **Configuration** menu.

- **Color Temperature**

Allows you to specify a color temperature between 3200 and 9300. Expressed in degrees Kelvin (3200K, 5400K, etc.). Lower numbers appear reddish white and higher numbers appear bluish.

Standard settings are:

- 9300K is close to the white of many computer monitors
- 6500K is the standard for color video, in both standard and high definition forms
- 5400K is a standard for graphics and black and white video
- 3200K is useful if the projected image is to be filmed or shot as part of a studio set illuminated with incandescent lights

For all color temperatures the color primaries; red, green, and blue are unchanged and reflect the native colors of the projector.

### 3.4.4 Channel Setup

Allows you to select a predefined channel (see [Channel Setup Menu, on page 3-12](#)).

### 3.4.5 Configuration

Use the **Configuration** menu to define general operating parameters and communications with other projectors and equipment, and to access other advanced processing and image adjustments affecting overall performance. The **Configuration** menu provides access to diagnostics, calibration tools and the **Service** submenu (password-protected).

#### Language

Choose the available language to use in the projector menus. The change will take effect immediately.

#### Output Options

##### Screen Image Orientation

Select the on screen image orientation from Front, Rear, Front Inverted, and Rear Inverted.

##### Frame Locking

Select how the projector controls the output frame timing based on the input signal. When set to **Frame Lock**, output image frames are locked to the input if possible. When locked, the output is always locked to the primary input. When set to **Free Run**, sets the output to the **Free Run Frequency** value. The projector will not display 3D content when set to **Free Run**.

**NOTE:** Frame locking on projectors in a ArrayLOC network can be controlled from one projector. See [Synchronize Frame Delay on page 3-54](#). When Synchronize Frame Delay is used, the master projector sets the frame delay for the synched projectors in the array.

##### Set Frame Delay

This control delays the output signal timing relative to the input signal timing by a fraction of a frame, and up to several frames. The minimum latency can vary based on the amount of scaling applied to the image. When using keystone or warping, an additional latency is required, depending on the amount of warp. The control is only available when the input signal is frame locked.

In **Free Run** mode, or in cases where the signal cannot be frame locked, the minimum latency defined by the scaling and keystone/warp is applied to the signal.

**NOTE:** Frame locking on projectors in a ArrayLOC network can be controlled from one projector. See [Synchronize Frame Delay on page 3-54](#). When Synchronize Frame Delay is used, the master projector sets the frame delay for the synched projectors in the array.

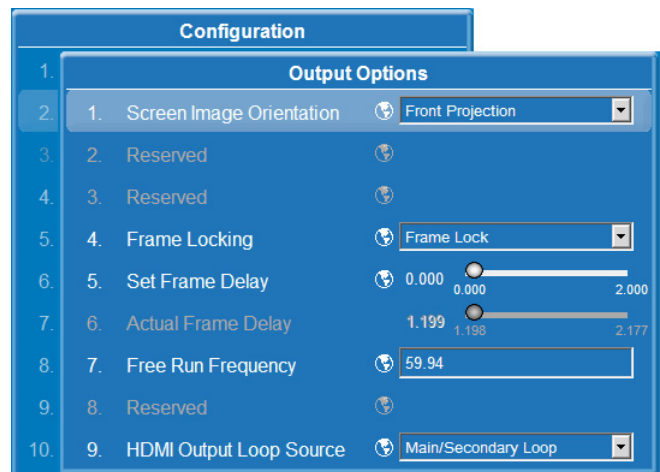
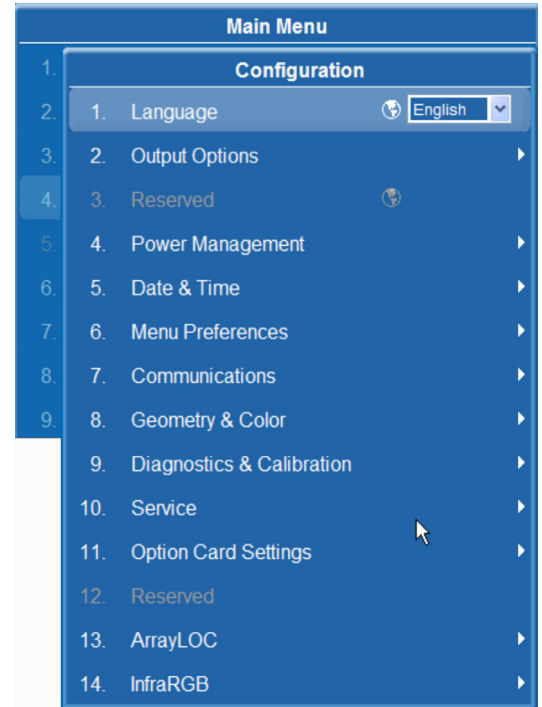

### Actual Frame Delay

Indicates the dynamically calculated, effective minimum frame delay for the projector. The calculated delay is affected by image shift, scaling, warp/keystone applied, and format. For example, the minimum latency can vary based on the amount of scaling applied to the image. When using keystone or warping, an additional latency is required, depending on the amount of warp.

### Free Run Frequency

This control sets the output video vertical frequency when **Frame Locking** is set to **Free Run**. The projector will not display 3D content when set to **Free Run**.

### HDMI Output Loop Source

The HDMI output options are:

- Choose **Direct Loop** to directly pass-through the HDMI input signals from the same Twin HDMI input card. The Input1 signal is looped to Output1, and the Input2 signal is looped to Output2.
- Choose **Main/Secondary Loop** to loop the main & secondary video to the outputs, regardless of which card these signals originate from. The main video signal is looped to Output1, and the secondary video signal is looped to Output2.

### Power Management

#### Auto Power Up

If there is an AC power interruption while **Auto Power Up** is enabled, the projector will resume operation in the same state as it left OFF. If the light engine is on and an image is showing when AC power is lost, the projector will automatically power back up with the light engine on, and an image will show when AC is restored.

#### Auto Shutdown Enable

When you select **Auto Shutdown** mode, and the projector is inactive for the time specified in **Turn Off Image After (min)**, the light engine dims and the shutter closes. If the projector continues to be inactive for the time specified in **Enter Standby After (min)**, the projector enters standby mode. Any activity during the time intervals cancels auto shutdown and returns the projector to normal operation.

#### Turn Off Image After (min)

Sets the time of inactivity after which auto shutdown dims the light engine and closes the shutter.

#### Enter Standby After (min)

Sets the additional time of inactivity after which auto shutdown initiates standby mode.

#### EM Stealth Mode

Check this option to operate the projector with the status LED display on the EM module turned off. The status LED is turned OFF during operation only. In standby mode, the status LED displays codes normally.

**NOTE:** *Option card LEDs on the EM remain visible.*

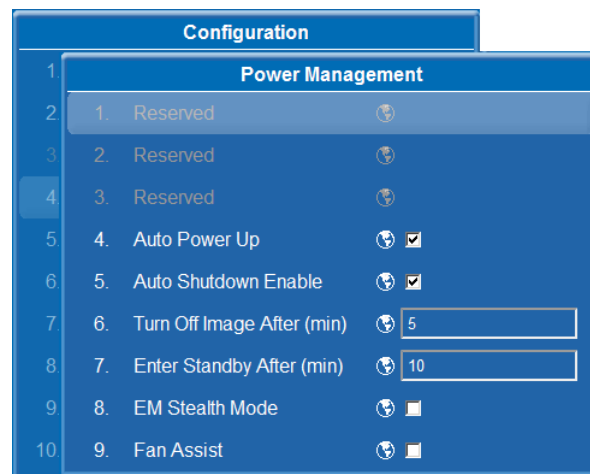

**Fan Assist**

Normal cooling uses temperature sensors to regulate fan speed. Fan Assist enables full speed fan operation on the Light Module (LM) when operating in high ambient temperatures or for long periods. This may help to reduce thermal problems and may prevent an emergency shutdown for thermal safety reasons. Fan assist increases noise levels due to the simultaneous full speed operation of the fans.

**Date & Time**

The current year-month-day, hour-minute-second. Changes made reset the projector real-time clock.

**Menu Preferences**

Adjust the appearance, content and/or location of on-screen menus and messages.

**Large Menu Font**

Select to enlarge menus and text. Adjust **Menu Location** to accommodate the change.

**Menu Location**

Select a location for the display of on-screen menus.

To create a custom menu location:

1. Choose a preset location.
2. Adjust **Horizontal Shift** and **Vertical Shift**.

**NOTE:** Avoid locations too close to a corner or edge to prevent cropping of larger menus.

**Horizontal Shift And Vertical Shift**

Adjusts the location of on-screen menus.

**Display Automatic Message Boxes**

Check to enable messages directly triggered by user actions, for example gamma or lens control messages.

**Display User Message Boxes**

Check to enable messages that are not directly triggered by user actions, for example signal information messages.

**Display Error Messages**

Choose how you want to be notified of errors detected in either the incoming signal or projector. Select **Screen** or **All** (default) to see brief on-screen messages. This is recommended during setup or testing of the projector. Or, select **Serial Ports** to receive messages using RS-232 or RS-422 serial communication only. To hide error message displays, such as during shows and presentations, select **Off** or **Serial Ports**.

**Splash Screen Setup**

Choose when to display a special splash screen image, such as your company logo, graphic, or message.

- **Always Off** – A splash screen never appears
- **Start-up Only** – The splash screen logo appears at projector start-up only.
- **Start-up And No Signal** – A splash screen appears at start-up and at any time when there is no signal.

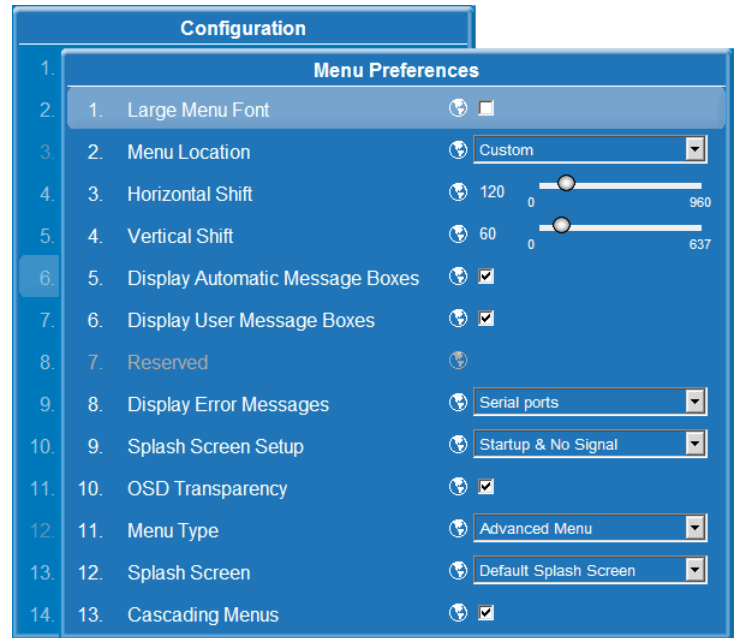

To add your own splash screen in addition to the default “CHRISTIE logo” splash screen, use the Web UI to download the desired bitmap (.bmp) file to the projector. This will overwrite any other user splash screen that has been downloaded.

**NOTE:** Only one user splash screen can be saved in the projector.

### OSD Transparency

Check this box if you want the On Screen Display (OSD) menu backgrounds to be transparent.

### Menu Type

Menu type is preset to **Advanced** which provides access to all projector functions.

### Splash Screen

Choose which splash screen is to be used; the default or user downloaded splash screen.

### Cascading Menus

Enable or disable cascading menus. When disabled, a single menu level will be displayed on the OSD at a time.

### Communications

Defines and controls how single or multiple projectors are linked with each other and with a controlling device. For detailed information see [Appendix C: Serial Communication](#).

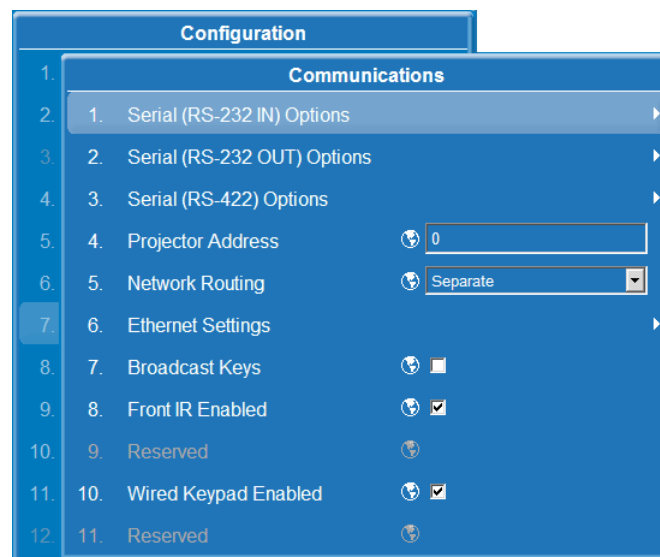

### Serial Options

**NOTE:** The *Synchronize Keys*, *Test Pattern*, *Color Enable* option lets you use the ArrayLOC network to forward IR remote keys from the master projector to all the synced projectors in the ArrayLOC group. See [Synchronize Keys](#), [Test Pattern](#), [Color Enable](#) on page 3-54.

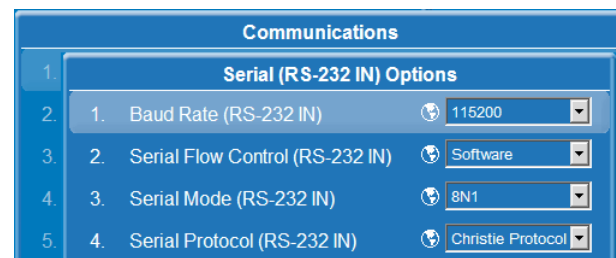

• **Baud Rate**

Determines the speed of communication to and from the projector on the RS-232 or RS-422 links. The maximum rate for the RS-232 is 115200; for RS-422 it is 19200. Set the baud rate to match that of your controlling device, such as your PC. See the documentation for the controlling device to determine the baud rate. In an existing network of projectors, if you discover that a projector has a different baud rate, use the pull-down list and select the correct baud rate using the ENTER key. Do not scroll this control with LEFT arrow key or RIGHT arrow key. Serial communication is always 8 data bits, no parity.

• **Serial Flow Control**

Determines whether software flow control is used when transmitting and receiving data on the serial port.

• **Serial Mode**

Select the serial data mode. The mode includes the number of bits, the parity and the number of stop bits.

• **Serial Protocol**

Select the protocol used on the serial communications port.

**Projector Address**

Displays the ID number assigned to the current projector. Enter a number up to 3 digits in length (such as “001”) to change the number.

The projector address enables you to communicate with a single projector within a multiple-projector application, for example when making adjustments to several projectors to create a seamless image. See the PROJ key described in *3.1 Using the IR Remote*.

**Network Routing**

**NOTE:** *Not applicable for stand-alone projectors or simple serial networks with only one type of controller and linking.*

Separate	— Networks Do not communicate with one another
RS232 and RS422 Joined	— Serial networks are joined, but Ethernet is isolated
RS232 and Ethernet Joined	— RS-232 and Ethernet are joined, but RS 422 is isolated
All Joined	— Network communications travel all networks

Figure 3-13 Network Routing List

• **Separate**

Select “**Separate**” (factory default) to keep RS-232, RS-422, and Ethernet messages on their respective paths instead of being broadcast to the other types of ports, see *2.6.1 Ethernet (Recommended), on page 2-12* and *Mixed Serial Network (RS-232 and RS-422), on page 2-15*.

• **RS-232 and RS-422 Joined**

Messages originating from an RS-232 or RS-422 controller are relayed to all RS-232 or RS-422 ports. Ethernet communication are isolated on the Ethernet port.

• **RS-232 and Ethernet Joined**

Messages RS-232 and Ethernet ports are relayed to both RS-232 and Ethernet ports. RS-422 communications is isolated. In the case of multiple Ethernet sessions over the single Ethernet connector, input on the RS-232 port is relayed to all Ethernet sessions; however, input from any Ethernet session is only relayed to the RS-232 ports.

• **All Joined**

All messages reach all ports, regardless of type. In the case of multiple Ethernet sessions, input on one Ethernet session are relayed to all other Ethernet sessions as well as to the RS-232 and RS-422 ports.

### Ethernet Settings

Access: **Main Menu > Configuration > Communication > Ethernet Settings.**

**NOTE:** *Recommended for Network Administrators only.*

- **IP Address**

Enter a valid and unique IP address for use on the network to which the projector is currently connected. This address will overwrite any previous IP address such as the projector factory-defined default. It takes approximately 10 seconds for the projector to respond at its new address.

- **TCP Port**

On some Ethernet networks, firewall restrictions may require that the port number of the projector be changed from its default of 3002. If so, enter a new valid port number here. It is highly recommended not to use a port # below 1000, as these ports are typically reserved for and used by common IP applications.

- **Subnet Mask**

Subnet Mask determines the subnet mask for the IP address and must be set manually.

- **Gateway**

This is the IP address of the gateway used to reach any non-local IP addresses; it must be set manually.

- **Host Name**

Set the hostname for the device.

- **Domain Name**

Set the domain for the device.

- **Mac Address**

Displays the MAC address of the projector (read-only).

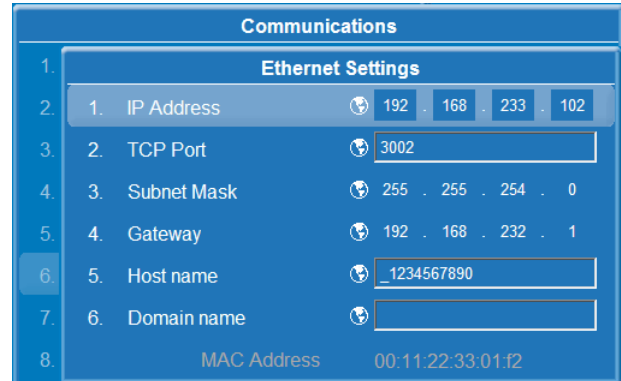

Communications	
Ethernet Settings	
1.	1. IP Address 192 . 168 . 233 . 102
2.	2. TCP Port 3002
3.	3. Subnet Mask 255 . 255 . 254 . 0
4.	4. Gateway 192 . 168 . 232 . 1
5.	5. Host name _1234567890
6.	6. Domain name
7.	
8.	MAC Address 00:11:22:33:01:f2

### Broadcast Keys

Use Broadcast Keys to relay all key presses received by the projector to all other projectors on the network.

### Front IR Enabled

Check this option to enable the front IR sensor.

### Wired Keypad Enabled

Check this option to use the wired keypad.



**Geometry & Color**

From the **Configuration** menu, select the **Geometry & Color** submenu when you need to modify overall color performance and/or image geometry for all sources.

• **Test Pattern**

Choose the desired internal test pattern, or select OFF to turn off a test pattern. Alternatively, use the TEST key for cycling through test patterns.

• **Geometry Correction**

Keystoning is typically caused by tilting the projector in relation to the screen, so that the lens surface and screen are no longer parallel to each other. Use the projector menu options to make basic keystone adjustments appropriate for flat screens. For complex geometry correction, for example for spherical screen, see the *TWIST User Manual (020-100143-xx)*.

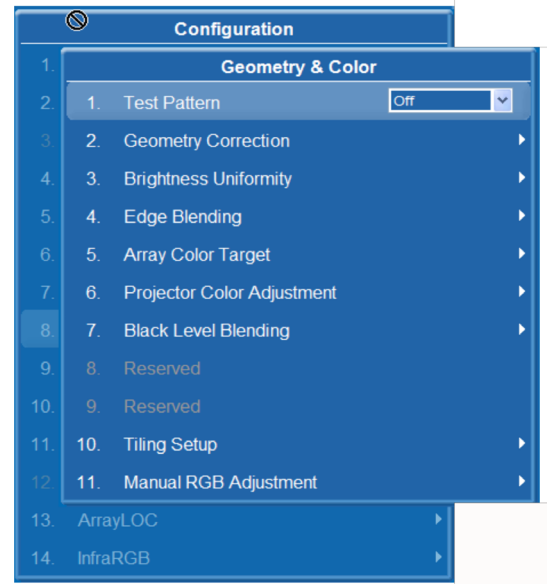

Settings to adjust keystone are in the **Geometry Correction** submenu. **Brightness Uniformity**, **Edge Blending** and **Black Level Blending** should be disabled before performing keystone adjustments.

Vertical keystone is used to correct a keystone image shape in which the top and bottom borders of the image are unequal in length, and both sides of the image are inclined toward the top or bottom edge, see **Figure 3-14**.

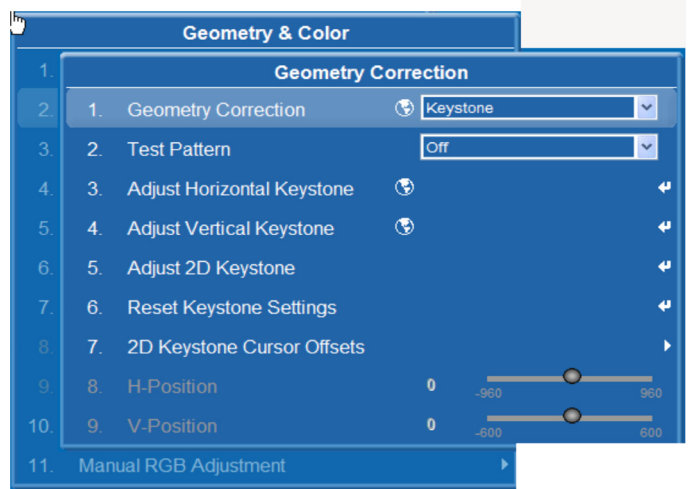

Figure 3-14 - Vertical Keystone

Horizontal keystone is used to correct a keystone image shape in which the left and right borders of the image are unequal in length, and the top and bottom are slanted to one of the sides. See **Figure 3-15**.

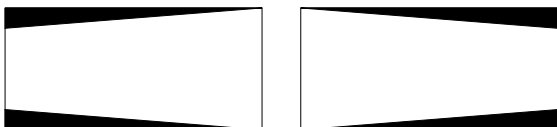
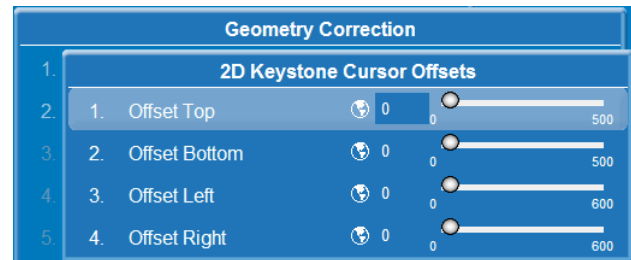

Figure 3-15 - Horizontal Keystone

### • 2D Keystone Cursor Offsets

Use these settings to move the cursor in from the corner point when a projector is overshooting and the cursors for adjustment are not visible. Move the cursors in from the corners and make the keystone adjustments in the normal way.



#### Adjusting an Image for Keystone Distortion

1. Enable keystone adjustments by selecting **Keystone** from the **Geometry Correction** drop-down list.

**NOTE:** This will enable the controls for performing 1D or 2D keystone adjustments.

2. Select a **Test Pattern**.

**NOTE:** The Grid test pattern is recommended.

3. Perform coarse keystone adjustment by using the Horizontal or Vertical Adjust setting. Use the LEFT and RIGHT arrow keys to make the adjustment.

**NOTES: 1)** If Vertical Keystone adjustments have been made, starting to do any Horizontal Keystone adjustments will erase the Vertical settings, and vice versa. **2)** The corner cursors are a guide as to how the image will be adjusted. The outside edge of a cursor will be the outside edge of the image. It may not be possible to exactly match the screen dimensions with the Horizontal and Vertical Keystone controls, but these settings can be refined when the 2D keystone settings are adjusted.

4. When adjustment of the corners is complete, select OK.

**NOTE:** A message will be displayed indicating that the projector is “Processing request”. The settings are applied to the displayed image, and will take approximately 10 seconds.

5. After the Horizontal or Vertical adjustments have been made, selecting **2D Keystone** adjustments will retain these settings. Fine adjustment can now be made by moving any single corner separately.

6. Use the arrow keys to move to the required corner.

**NOTE:** The current corner will be displayed in red.

7. Press ENTER to select the corner.

**NOTE:** The current corner will be displayed in green.

8. Use the arrow keys to move the selected corner to match the screen.

9. Press ENTER again, to save that position for the corner.

10. Repeat steps 6 to 9 to adjust all 4 corners until they match the screen.

11. Select OK to apply the new corner positions to the image.

**NOTE:** A message will be displayed for approximately 10 seconds indicating that the projector is “Processing request”.

Under certain combinations of extreme keystone co-ordinates and specific signal frequency, a keystone image may result that is outside the bandwidth limitations of the projector. When attempting to apply the keystone settings, a message will pop up on the OSD, indicating that the bandwidth has been exceeded and the keystone cannot be applied. The cursor co-ordinates for keystone adjustment will remain at the failed keystone position. This will allow the user to make minor changes and attempt to reapply the corner settings. Either the co-ordinates must be adjusted, or the free run frequency must be changed to fall within the allowed bandwidth.

The **Func+Help** key combination will immediately disable the **Keystone**, **Brightness Uniformity**, **Edge Blending** and **Black Level Blending** features. This is helpful when, in some extreme keystone configurations, some image corruption may appear and/or the menus may not be readable. Although **Func + Help** disables these features, it will not overwrite their settings. If keystone is simply enabled again, the same image corruption may occur. After pressing **Func + Help**, it is recommend to immediately “Reset Keystone Settings”, which will set all keystone co-ordinates to zero.

**Brightness Uniformity**

**Brightness Uniformity** provides further refinement of displays already matched for their primary colors and overall light output. Use the **Brightness Uniformity** menu options for basic adjustments so that no area appears brighter than another. In the **Brightness Uniformity** menu, enable the **Brightness Uniformity Enable** check box to access a multitude of adjustments for light output control in specific areas throughout the image. Your settings apply as long as the **Brightness Uniformity Enable** check box is enabled.

While making adjustments, enable the **Coarse Adjustment** check box to apply **Brightness Uniformity** settings with a large granularity. **Coarse Adjustment** helps identify brightness changes and accelerates projector response time while adjusting settings. To disable the **Brightness Uniformity** function, delete the **Brightness Uniformity Enable** check mark.

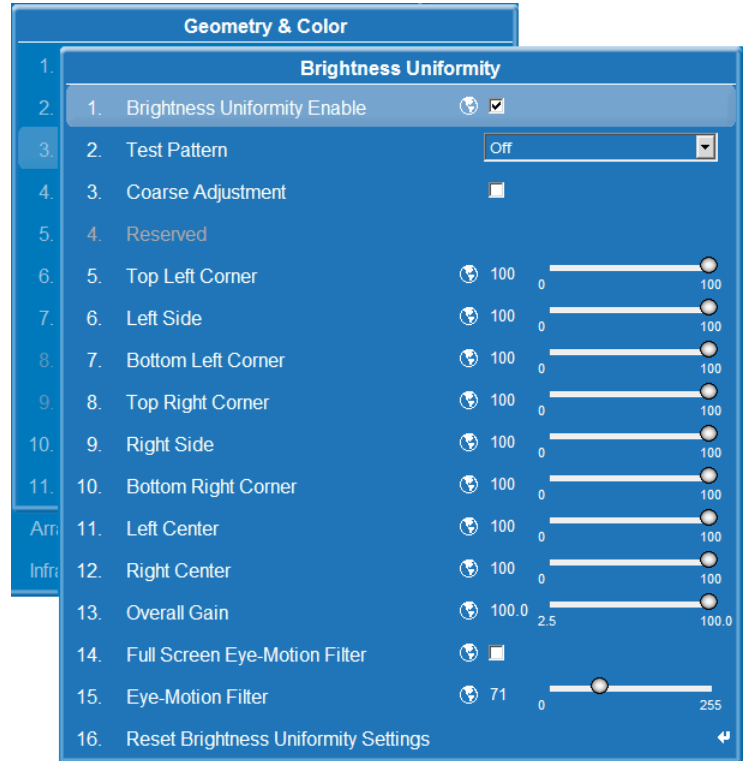

To correct brightness uniformity for a complex screen setup, see the *TWIST User Manual (020-100143-xx)*.

When used to refine screens already matched for their primary colors and overall light output, proper adjustment of **Brightness Uniformity** can create an exceptionally smooth screen in which:

- No area of the screen appears brighter than another
- Light output from one screen closely matches adjacent screens

Although the **Brightness Uniformity** control can be used for a stand-alone projector, it is particularly useful for setting up and maintaining tiled images that form a cohesive display wall in which the color “cast” and light output appear uniform throughout each image as well as throughout the entire wall. The procedure provided here assumes a multiple-screen application.

**NOTE:** For information about the Eye Motion Filter fields, see [Noise Reduction on page 3-27](#).

**IMPORTANT: Read through the entire procedure before attempting to adjust the brightness uniformity controls.**

### Adjust Brightness Uniformity

1. Adjust the primary colors as described in *Adjust Projected White and Primary Colors for the Array on page 3-56* procedure, before attempting to work with brightness uniformity. This ensures that primary colors, color temperature, and maximized light output are all well matched from one screen to another. These matches are needed before you can achieve good brightness uniformity results.

**IMPORTANT!** *Double-check that all WHITES and LIGHT OUTPUT are well-matched.*

2. Select the **Brightness Uniformity** check box. This will enable access to the uniformity controls and will apply the settings to your image.
3. Select the 13-Point test pattern for Full White for display. The 13-Point test pattern provides nine screen “zones” with 13 targets, see **Figure 3-16**.

4. Determine by eye or meter which areas need to be adjusted.

**For Best Results.** Rather than examining the CENTER of each zone when assessing **Brightness Uniformity** adjustments focus on extreme EDGES as indicated in the illustration at right.

5. Enable **Coarse Adjustment** to quickly apply display changes without redrawing the whole image.
6. Use sliders to achieve relative uniformity in the necessary zone.
7. Disable **Coarse Adjustment** to accurately display changes as you make them.
8. Use sliders for fine adjustment as necessary in the required zones.
9. Adjust overall gain to ensure that overall light output remains well matched from one screen center to the next.

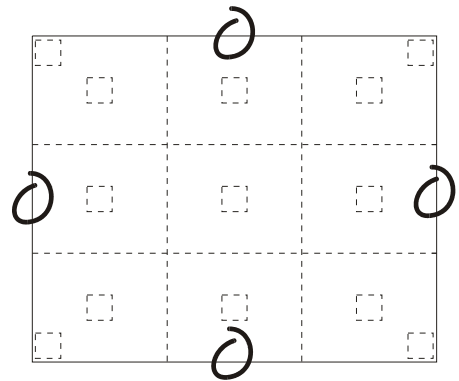

Figure 3-16 13-Point Test Pattern

### Cancel Brightness Uniformity

If you do not want to use or apply Brightness Uniformity settings, clear the **Uniformity Enable** check box at the top of the **Brightness Uniformity** menu.

### Edge Blending

The **Edge Blending** submenu provides a range of basic controls for smoothing together the overlapping bright edges of multiple adjacent projected images to create a single larger “seamless” image. These controls, which primarily affect white levels, are typically used in conjunction with mechanical lens blinders (optional), which are installed on the front of the projector and which primarily affect black levels. Brightness uniformity adjustment, if desired, should be performed first. The **Edge Blend** or **Grid** test pattern is useful for the mechanical setup of the projectors. If necessary, adjust **Black Level Blending** first with the **Black** test pattern, then use the **White** test pattern to blend the white levels on the blend edges. The final step is to check the blended image with an external source. There is a centerline (both horizontal and vertical) in the Edge Blending test pattern. The intersection of these lines is the true center of the projector display area.

The **Show Blending Overlap** control enables or disables edge blending overlap. When enabled, this will make the size of the Edge Blending regions obvious. This control should only be used during setup.

For information about advanced blending of complex configurations, for example with spherical screens, see the *TWIST User Manual (020-100143-xx)*.

In simple terms, a blend appears as a gradient strip along an edge of a projected image. It is darkest along the extreme edge of the image, and lightens nearer to the rest of the image (**Figure 3-17**).

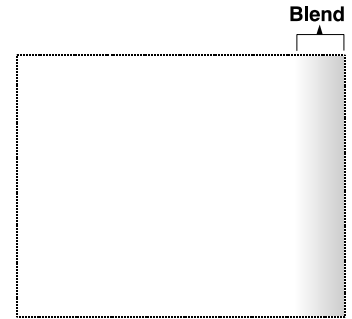

Figure 3-17 Edge Blending

**How Are Blends Used?**

In multiple-projector walls, complementary blends between neighboring images can compensate for the extra “brightness” or intensity where these edges overlap. By controlling blend width and other properties, you can achieve uniformity across the group of images. Visible overlaps disappear (**Figure 3-18**). For best results, use the same projector model and type throughout your display wall. In addition, avoid high-gain screens whenever possible; the optical performance of such screens demands minimal image offset, so projectors must be located very close to one another.

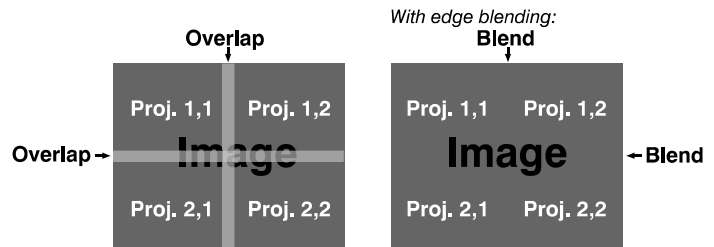

Figure 3-18 Edge Blending Concept

Edge blending software controls are located in the **Edge Blending** submenu, which can be accessed using **Configuration > Geometry & Color > Edge Blending**. The **Advanced Edge Blending** option opens to the second page of the **Edge Blending** submenu.

**Edge Blending Menu**

Use edge blending controls to set the precise width, shape, and midpoint you need to blend overlapping edges together smoothly.

**NOTE:** For information about advanced blending of complex configurations, for example with spherical screens, see the *TWIST User Manual (020-100143-xx)*.

**Blend Width**

Determines how much area is used for blending along an overlapping edge. Slide bar values represent the number of pixels used for the blend. For example:

- A setting of 8 creates a blended edge 8 pixels wide.
- A setting of “0” signifies no blending.

For best results in most applications, use a blend width of 12-25% (for example with a screen size of 1920 × 1200, 230-480 pixels). **NOTE:** Ranges: 0-960 horizontal, 0-600 vertical.



### Show Blending Overlap

Turns your defined blend width area to solid gray so that, if needed, simply overlapping the gray bars can seamlessly align 2 adjacent images. Clear the **Show Blending Overlap** check box to reactivate the blend effect.

### Other Functions

For convenience, the **Edge Blending** submenu also includes related options for enabling a test pattern. Such functions duplicate those provided elsewhere in the menu system.

### Advanced Edge Blending Controls

Use advanced edge blending controls to more finely control the blend curve.

#### Blend Shape

Determines the rate of roll-off across the blend width, i.e. how quickly the white levels across the blend change from light and dark. Increasing the **Blend Shape** setting accelerates the rate of change at both extremes so that less of the region appears mid-gray. Decreasing the **Blend Shape** setting slows the rate of change so that more of the region appears mid-gray. For most applications, this subtle control is best left close to 50.

#### Blend Midpoint

Determines the white level at the blend midpoint (the point equidistant between the beginning and end of the blend). Increasing the **Blend Midpoint** setting creates a blend that appears brighter than the rest of the image. Decreasing the **Blend Midpoint** setting creates a blend that is darker than the rest of the image. A setting of 50 means the midpoint is approximately 50% black; for best results in most applications, keep fairly close to this default.

### Edge Blending Procedure

**NOTES: 1)** Before attempting to work with edge blending software functions, align the projectors/images by correctly overlapping the displays from your intended external source. **2)** Match colors and the brightness uniformity.

**NOTICE:** For a shared edge, all blend procedures and settings should be identical on both projectors.

1. Start with 2 projectors. Display full white field test pattern from both.
2. In the **Edge Blending** submenu, enable *Edge Blending* by selecting **Standard** for non-warped images.
3. **Set Starting Points For Adjustment.**
  - a. Set all blend widths to 0.
  - b. Go to **Advanced Edge Blending** and set all options to 50.
4. **Set Blend Width.** On one projector, increase the **Blend Width** for an overlapping edge (for example, if the projector image is on left, its right edge overlaps the adjacent image by adjusting **Right Blend Width**). Use the same setting on the second projector for this shared edge.

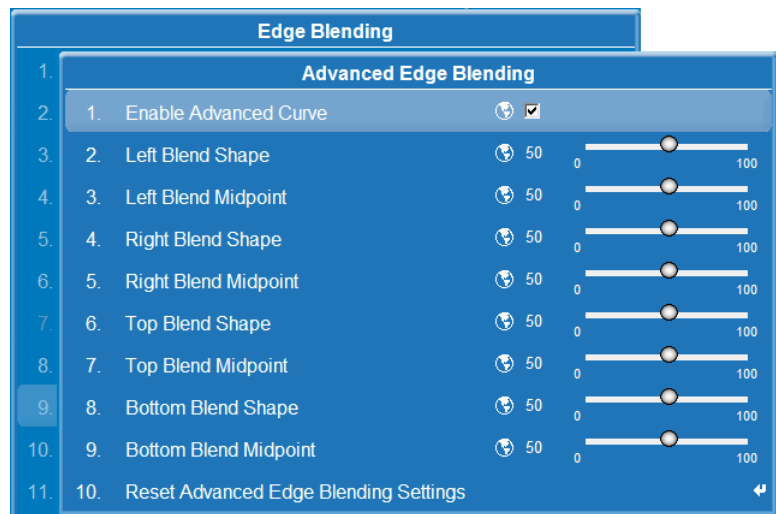

5. Re-adjust width (both projectors) until the overly bright band at the midpoint of the overlapping blends disappears or *just* changes to very light gray. For the shared edge, use the same **Blend Width** setting on each projector.
 

**NOTE:** *If the best blend appears to be between 2 settings, choose the wider setting for both projectors.*
6. Check the blend and adjust as required:
  - To lighten the overall blend, increase the **Blend Midpoint** in both projectors.
  - To darken the overall blend, decrease the **Blend Midpoint** in both projectors.
  - To fine-tune the amount of mid-gray intensity (as opposed to black/white) in the blend, adjust **Blend Shape** in both projectors.
7. Repeat with remaining projectors/overlaps.
8. Check completed display wall with the desired external signal.
9. If necessary, adjust the mechanical alignment to maintain perfect pixel-on-pixel alignment over time.

In applications where you are projecting only white or light images, the Blend Width may be slightly higher; set according to how much overlap you have between images.

**NOTE:** *Recommended overlap is 12.5%–25%.*

**Array Color Target**

See [Array Color Target on page 3-48](#).

**Projector Color Adjustment**

See [Projector Color Adjustment on page 3-50](#).

**Black Level Blending**

Brightens the center regions to match adjacent blend regions when edge blending multiple projectors. The **Black Level Blending** submenu provides controls that allow you to adjust the black level hues of multiple adjacent projected images to create one large seamless display.

**NOTES:** **1)** *Adjust edge blending before adjusting black levels.* **2)** *Blinders are recommended for fixed installations.* **3)** *Do not use black level blending if TWIST was used for the geometry.*

**Black Level Blending Procedure**

**NOTES:** **1)** *Adjust edge blending before adjusting black levels.* **2)** *The zones in Black Level Blending menu correspond to the Edge Blend zones. If a given Edge Blend zone width is set to 0 (i.e. no blend on that side), then the corresponding BLB zone is disabled. It only becomes accessible when that Edge Blend zone is active.*

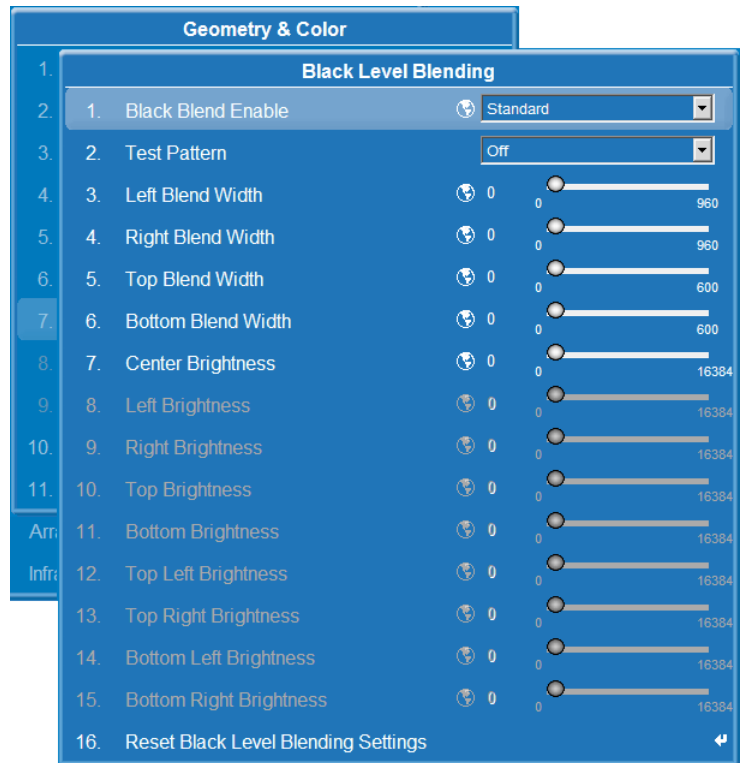

1. Start with 2 projectors. Select the black test pattern for both projectors from the **Geometry & Color** submenu.
2. In the **Black Level Blending** submenu, enable black blending.
3. Set the blend width.
4. Working with one projector at a time, use the center brightness sidebar to adjust the center brightness (brightness of the non-blended region) so that the center intensity matches that of the brightest blended region (the center of all images when blending a 2 x 2 display is the target area).
5. You can choose which of the next 4 options, Top, Bottom, Left, Right, to use depending on which edge of the projector you are working with has been edge blended. The blend width can be adjusted to line up properly but by default it corresponds to the edge blending setting determined for that edge.
6. The brightness and black hues of the blended region can be adjusted in more detail in case fine-tuning is needed (may be necessary only for blending a 2 x 2 projector display because of blending differences for the sides and center).

**NOTES:** **1)** The menu options vary depending on the edge blending parameters. **2)** You may need to re-adjust the black level brightnesses following the overlap adjustments on each blended edge. **3)** When adjusting 6 or more projectors, you need to ensure that the hue and brightness of each target area is matched as closely as possible.

### Manual RGB Adjustment

**⚠ CAUTION** These adjustments can turn on multiple RGB LEDs simultaneously, which uses more power and increases the possibility of overheating.

The **Manual RGB Adjustment** menu lets you manually adjust the native projector color space by adjusting the LED power levels. The brightness of unsaturated colors can be significantly increased by turning on multiple RGB LEDs simultaneously.

#### Interaction with ColorLOC

When Bright/ColorLOC is **OFF** or in **Fixed** mode, these adjustments can be used to define the color gamut. In **Cool** or **Bright** mode, the projector automatically moderates the LED power level to maintain the color gamut selected through the **Array Color Target** menu. See [How Color Settings Interact in a Mirage WU-L Array on page 3-61](#).

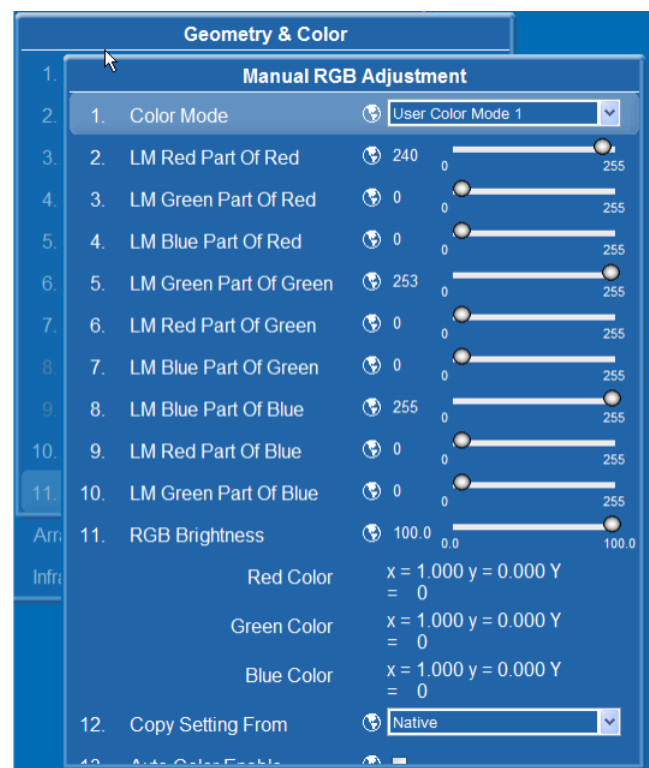



**NOTICE:** Only Christie accredited service technicians should attempt this procedure. For general use, adjust color and brightness using ArrayLOC.

**Table 3.4 Manual RGB Adjustment menu**

Option	Description
Color Mode	Use this dropdown list to select the color mode: Native, EBU or User Color presets which control the LM LED power settings for each color. The settings for Native mode are locked.
LM Red Part Of Red	Changes the power of the red LED for the red color.
LM Green Part Of Red	Changes the power of the green LED for the red color.
LM Blue Part Of Red	Changes the power of the blue LED for the red color.
LM Green Part of Green	Changes the power of the green LED for the green color.
LM Red Part Of Green	Changes the power of the red LED for the green color.
LM Blue Part Of Green	Changes the power of the blue LED for the green color.
LM Blue Part of Blue	Changes the power of the blue LED for the blue color.
LM Red Part of Blue	Changes the power of the red LED for the blue color.
LM Green Part Of Blue	Changes the power of the green LED for the blue color.
RGB Brightness	Controls the overall brightness of the LEDs. If ArrayLOC is enabled, the adjustment must be made on the master projector.
Red Color, Green Color, Blue Color	Displays the color values as reported by the sensors.
Copy Setting From	Copies the <i>Color Mode</i> settings from an existing preset to the current preset.
Auto Color Enable	Automatically select color based on slider being adjusted.

**Diagnostics & Calibration**

Make the necessary adjustment from the **Configuration** menu options described below.

**Test Pattern**

Choose the desired internal test pattern to display, or select **Off** to turn OFF a test pattern. Alternatively, use the **Test** key for cycling through test patterns.

**Grey Level**

Set the level of grey for displaying in the full gray field test pattern.

**Freeze Image**

Check this option to freeze an incoming image on a single frame in order to examine details. For example, in moving images it is sometimes difficult to observe artifacts such as external de-interlacing/resizing and signal noise. Uncheck to return to normal.

**Color Enable**

Use this option to select a color while working with color temperature, input levels or other setup parameters.

**NOTE:** Use the remote to enable/disable colors by entering the Function code. See [Function Key on page 3-5](#).

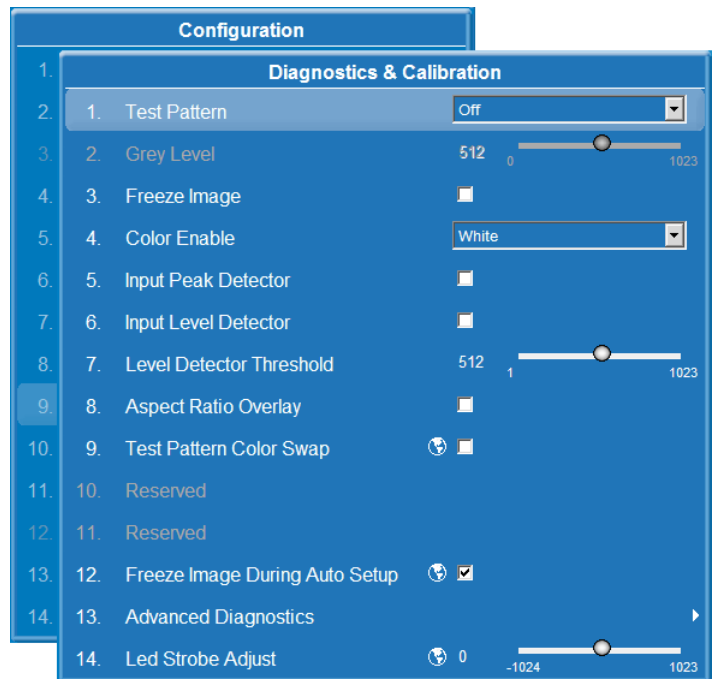

### Input Peak Detector

This is a fast method for defining individual input levels, and improving the accuracy of input levels set by the *Auto Input Level* function. Enabling the **Peak Detector** activates a special operating mode for detecting *only* pixels that are considered black or white; all other levels are displayed as a mid-level gray. When used with a 16-step grayscale pattern in which the 2 black and white bands are known to be at opposite edges of the image, you can watch these isolated areas while adjusting individual black levels, and Input drives until both bands are just visible. Images from this source will display correct blacks and whites without crushing or washing out.

### Input Level Detector

The **Input Level Detector** check box enables specific thresholds for blacks and whites. Input levels that fall below a specified level value (see below) are displayed as black, and all others are displayed as white. To use:

1. Enable **Input Level Detector** and display a continuous grayscale.
2. Set **Level Detector Threshold** to near black (such as 200).
3. Adjust Offsets to minimize area of black stripe.
4. Set **Level Detector Threshold** to near white (such as 800).
5. Adjust Gains to minimize area of white stripe.

### Level Detector Threshold

**Input Level Value** defines the value to be used by the **Input Level Detector** in recognizing blacks and whites. See **Input Level Detector**, above.

### Aspect Ratio Overlay

Check this box to display an overlay pattern over the image. The overlay shows the boxes corresponding to the size and shape of different aspect ratios.

### Test Pattern Color Swap

This function swaps the green and red color when drawing the Grid test pattern, and may be helpful when adjusting convergence on the projector.

### Freeze Image During Auto Setup

If selected, this will hide temporary image artifacts that may appear during the auto setup procedure.

### Advanced Diagnostics

Allows for the setting of advanced controls which may cause image disruption, including the possible loss of the OSD menus. These disruptions are only temporary; pressing EXIT to exit the menu will restore the settings and allow normal operation.

#### Output Peak Detector

This is an aid for setting up the input levels. It causes the data to be processed so that very bright and very dark signals display as fully ON or OFF, and everything in-between is set to mid-level gray. The Input levels should be adjusted so that bright and dark objects in the image are just visible.

#### Output Level Detector

This is an aid for setting up the Input levels. It causes the data to be processed so that all levels below a specified value are set to black and all above (and including) it are set to white.

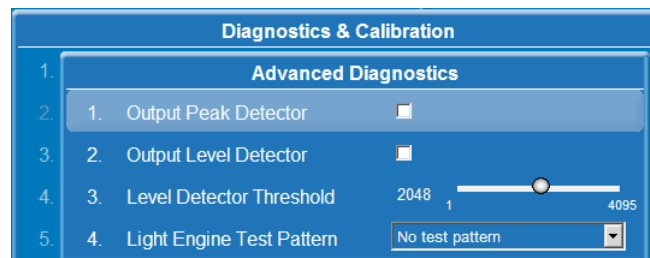

**Level Detector Threshold**

Specifies the threshold to be used by the level detector.

**Light Engine Test Pattern**

One of 3 light module test patterns may be displayed: black, white, or grey scale.

**LED Strobe Adjust**

During power up the projector will automatically optimize LED strobe timing, the time between when a LED is told to turn on versus when it actually does turn on. If the strobe timing is not optimal, color banding may be seen on grey levels. Use this advanced option to correct color banding by adjusting the slider left or right as required.

**Service**

The Service menu is intended for use by accredited Christie service technicians only. It is passcode protected.

**Option Card Settings**

Allows adjustment of any settings specific to each option card that is currently installed in the projector.

**ArrayLOC Menu**

Use this menu to set up your projector array color and brightness.

By default ArrayLOC is enabled and configured to automatically display a moderately saturated gamut at the maximum brightness the array can support.

For an overview of projector and source color settings, see [3.5 How Color Settings Interact in a Mirage WU-L Array, on page 3-61](#).

For an annotated walkthrough for setting up ArrayLOC and fine tuning the setup, see [6.6.9 Bright/COLORLOC Setup Walkthrough, on page 6-12](#) in the troubleshooting section.

**NOTE:** While working in the ArrayLOC menus and submenus, ArrayLOC displays a warning popup on the affected projector if adjusted settings fall outside the range the system can adjust for. Warnings include:

- Minimum brightness not met (BCLOC disabled)
- Minimum brightness not met (Warning)
- Min Gamut not met (BCLOC disabled)
- Min Gamut not met (Warning)

**Bright/ColorLOC Mode**

Use this option to set the **Bright/ColorLOC** mode.

- In **ALL** modes (except OFF), the projector:
  - Sets the flag to execute the Array BCLOC algorithm.
- In **Cool** or **Bright** mode, the LM color adjustment options on the **Manual RGB Adjustment** menu are disabled.

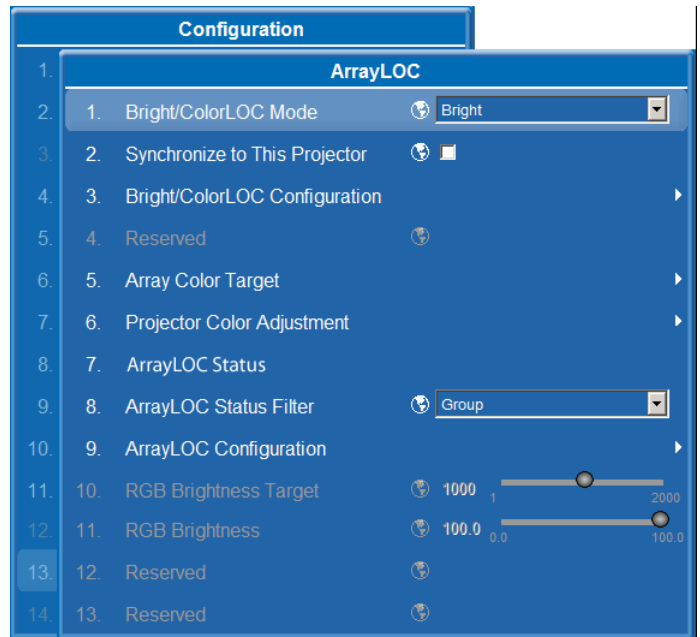

- **Cool** mode: LED control performed by BCLOC. Color Space Correction is also performed electronically to achieve the target color space.
- **Bright** mode: This is the recommended (default) mode. The **Bright** mode is the same as **Cool**, except multiple LEDs may operate at the same time. This mode should provide brighter performance, but it will also generate more heat in the system.
- In **OFF** mode, the projector:
  - Disables BCLOC. Color control is done manually through **Manual RGB Adjustment** and manual color settings.
  - Clears the flag to execute the Array BCLOC algorithm.
  - Restores the LM color adjustment options on the **Manual RGB Adjustment** menu and the manual color adjustments.
  - Ignores setting changes sent by a projector with the master flag set ([Synchronize to this Projector on page 3-46](#)).
- In **Fixed** mode, the LED setting is derived from **Manual RGB Adjustment**; **Color Space** correction is performed electronically to achieve the **Target Color Space**.

### Synchronize to this Projector

To broadcast the **ArrayLOC** settings to the projectors in your array, you must define a projector as the “master” by checking the option **Main Menu > Configuration > ArrayLOC > Synchronize to This Projector**.

The master projector has access to most settings under the **Bright/ColorLOC Configuration** and **Array Color Target** submenus. These settings are greyed out on the other projectors in the array to prevent conflicting information from being sent to the array.

You can change which projector is the master at any time, by checking the **Synchronize to This Projector** option on another projector. The previous master projector automatically releases the setting.

See [ArrayLOC Status on page 3-52](#). See **Bright/ColorLOC Configuration > Bright/ColorLOC Array Status** to check projector information.

A projector with **BrightColorLOC** mode turned **OFF** ignores BCLOC changes from master projectors.

If at some point you are working with another projector within your array or group, and decide to make some setting changes, you may not be able to do so as some settings will be locked (grayed out) because their projectors may not be the current master. You can however select the new projector as the master (as described above), and make your required changes. The previous master projector will relinquish control.

**Bright/ColorLOC Configuration**

Use the **Bright/ColorLOC Configuration** menu to assess and work with the capabilities of the projectors in the group or array.

**Minimum Brightness**

Use this option to set the minimum brightness (as a percentage of the target brightness) that the array will target, and to set the threshold for alerts from projectors that cannot achieve the minimum. Projectors that fall below the minimum are excluded from the calculations of the common gamut and common brightness. Excluded projectors are flagged in the Bright/ColorLOC Array Status window with an **M**.

If the projector falls below the minimum, the projector operates at its current brightness and gamut. Changes will not be made.

**Minimum Gamut**

Use this option to set the minimum gamut (as a percentage of the target gamut) that the array will display, and to set the threshold for alerts from projectors that cannot achieve the specified minimum. Projectors that fall below the minimum are excluded from the calculations of the common gamut and common brightness. Excluded projectors are flagged in the capabilities window with a **m**.

If the projector is unable to maintain the minimum gamut, the projector operates at the current brightness and color gamut. LED drive level changes and electronic color correction is not done.

**NOTE:** *The failure point for maintaining minimum gamut is calculated as:*

$$\frac{a}{b} < \text{minimum gamut}$$

*For example, see the diagram at the right. Where b is the length of the line from the target white point to the target color primary, and a is the length of the line from the target white point to the intersection of the projector capability gamut line and the line from the target white point to the target color primary.*

**Projector Capability**

Identifies the projector capability with respect to the array-common color gamut as defined by Color Target and Brightness Target. 100% indicates the projector meets the target. A greater number indicates that the projector can exceed the target. A smaller number indicates how much the projector falls short of meeting the target.

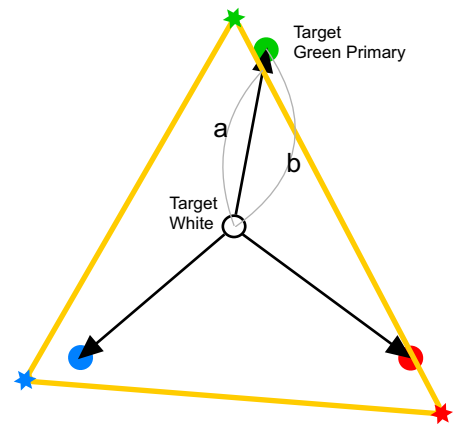
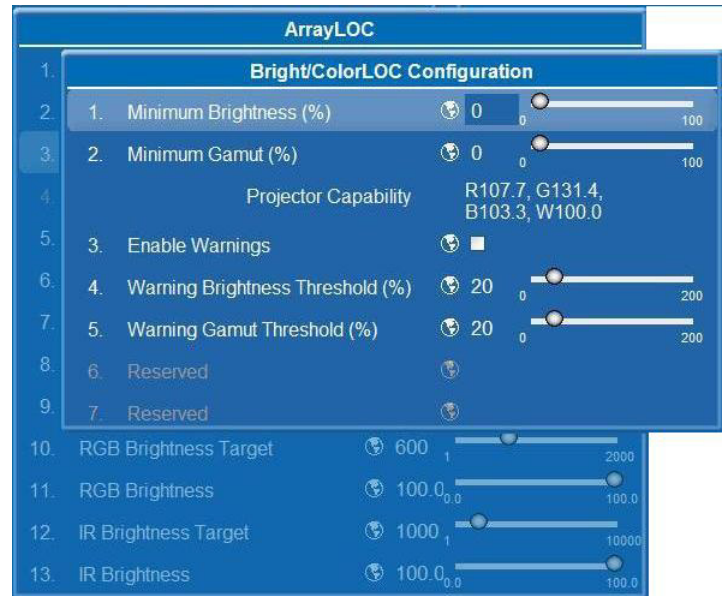

### Enable Warning

Check this option to enable warnings when either the projector brightness capability or color capability falls below the specified warning threshold.

### Warning Brightness Threshold

Set the **Brightness Warning Threshold** as a percentage of the brightness target. When the common brightness reaches the warning level, all projectors in the BCLOC group issue a warning message: “Projector fails to meet warning brightness threshold of xx%; capability xx%.”

Changing this option:

- Recalculates the internal brightness warning level.
- If warnings are enabled, checks the current common brightness capability against the brightness warning level.

### Warning Gamut Threshold

Set the **Warning Gamut Threshold** as a percentage of the target gamut. When the common gamut falls below this level, all projectors in the BCLOC group issue a warning message: “Projector fails to meet warning gamut threshold of xx%; capability Rxx% Gxx% Bxx%”.

Changing this option:

- Recalculates the Internal gamut warning level.
- If warnings are enabled, checks the current common gamut against the gamut warning level.

### Array Color Target

Use this menu on the master projector to set the color target for the projector array. The settings apply to the projectors belonging to the same **Brightness/ColorLOC** group, which are set to synchronize with the group. These settings are enabled on master projectors only.

Choose **Maximum** to view the common color gamut values for the array.

**NOTE: 1)** *The recommended procedure for setting the color target for a projector array follows the description of the menu items. 2)* *If you are setting up a single projector, create an array of one and make it the master to enable the color controls.*

#### • Target Color Space

Sets the color space for the projector array. Changing this option displays the **red/green/blue x/y** associated with the selected option. Selecting one of the user-defined color spaces displays the last saved values.

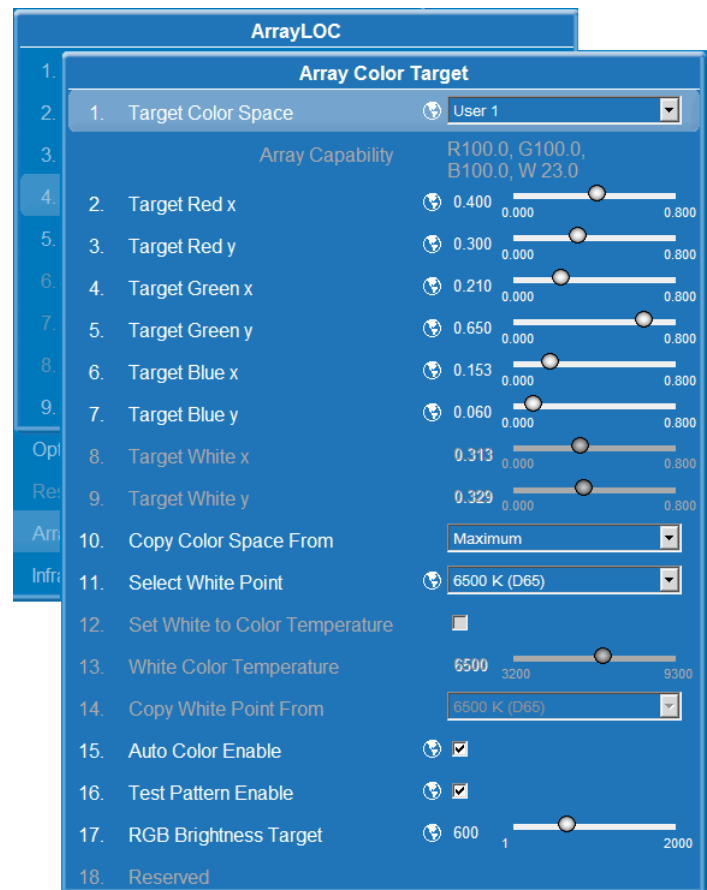

- **Array Capability**

Indicates the current projector capability with respect to the selected color target and the target white point. The information format is:

**R 999.9 G 999.9 B 999.9 W 999.9**

**R/G/B** - Indicates the percentage achieved of the red, green, and blue target gamut.

**W** - Indicates the percentage achieved of the product of the RGB brightness, and the target brightness.

- **Target Red X/Y, Target Green X/Y, Target Blue X/Y**

Displays the color values associated with the selected target color space.

- Only values for user defined color spaces (User 1 through 4) can be changed. Changes to these values update the associated color space chromaticity.
- When the **Target Color Space** is set to **Maximum**, the values reflect a color space larger than capable for the best array color saturation.

- **Target White X/Y**

Displays the white x/y values associated with the **Select White Point** option.

- Only values for user defined white points (User White 1 through 4) can be changed.
- When **Set White Color to Color Temperature** is checked, the values are calculated based on the specified **White Color Temperature**.

- **Copy Color Space From**

Updates the **Target Red x/y, Green x/y, Blue x/y** values based on the color space selected from the list. This option is available only when the **Target Color Space** is set to one of the user-defined options, User 1 through 4.

- **Select White Point**

Sets the white point for the array. Changing this option un checks the **Set White Color to Color Temperature** check box and updates the **Target White x/y** values and the **White Color Temperature**.

- **Set White to Color Temperature**

Check this option to recalculate **Target White x/y** values based on the specified standard **White Color Temperature**. This option is available only when **Select White Point** is set to one of the user-defined options, User White 1 through 4.

This option is unchecked automatically when you change the **Select White Point** option.

- **White Color Temperature**

Use this option to specify the white color temperature used to calculate and update the **Target White x/y** values. This option is available only when **Set White to Color Temperature** is checked.

- **Copy White Point From**

Updates **Target White x/y** values, **Set White Point to Color Temperature**, and **White Color Temperature** based on the white point selected from the list. This option is available only when the **Select White Point** option is set to one of the user-defined options, User White 1 through 4.

- **Test Pattern Enable**

Check this option to enable the automatic display of a flat white test pattern when you select the *Array Color Target* menu.

The test pattern is turned OFF automatically when you EXIT the menu.

- **RGB Brightness Target**

Use this option to adjust the RGB brightness target for the array.

- **RGB Brightness**

Use this option to adjust the brightness of the projector array as a percentage of the target brightness.

- **Bright/Color Group**

Identifies the BCLOC group to which the projector belongs.

The BCLOC group identifies a subset of projectors in the array that are used in the Array BCLOC algorithm, and are included in the Array Capability data table.

### Projector Color Adjustment

Use this menu to make ArrayLOC projector-specific color adjustments. These controls are used to fine-tune the matching performed by ArrayLOC after the targets have been set through the **Target Color Space** menu.

These adjustments compensate for the projection system as a whole, including loss of brightness or color shift due to lens, mirror, and screen. For example, the mirror might not reflect blue 100 percent, or the screen might absorb more blue. Measure the output at the screen with a color meter and use this option to adjust the blue until you get the array color target value at the screen.

Adjustments are specific to the target color space. If the color space is changed for the array, projector adjustments can be copied from the old target color space and fine-tuned again.

See also [Adjust Projected White and Primary Colors for the Array on page 3-56](#).

- **Target Color Space**

Use this option to change the color space.

Changing this option applies the red/green/blue x/y values associated with the selected option. It also updates the red/green/blue components of each color on this menu. Selecting one of the user-defined color spaces displays the last saved adjustment values.

The Target Color Space option is enabled only on the master projector. All other projector-specific color adjustments on this menu are available on all projectors at all times.

- **Red Part/Green Part/Blue Part of Each Color**

Use these options to make projector specific color adjustments to the selected **Target Color Space**.





- **Clear Adjustments**

Use this option to reset the color values to the color adjustment default values: 0 or 100

- **Reset Current Adjustments to Default**

Use this option to reset the red part/green part/blue part of each color to the default values set at the factory during calibration. Color adjustment default values are shown in *Black Level Blending, on page 3-41*.

- **Auto Color Enable**

Check this option to enable system color to change based on the cursor position in the **Array Color Target** menu.

- Red/green/blue part of red changes the system color to red.
- Red/green/blue part of green changes the system color to green.
- Red/green/blue part of blue changes the system color to blue.
- All other menu options change the system color to white.

The color resets automatically when you exit the menu.

- **Test Pattern Enable**

Check this option to enable the automatic display of a flat white test pattern when you select the **Array Color Target** menu.

The test pattern is turned off automatically when you exit the menu.

- **Copy Adjustments From**

Use this drop-down menu to copy the adjustment values from the selected color space to the current color space.

- **White Brightness Adjustment**

Use this option to adjust the RGB brightness for the projector.

### ArrayLOC Status

To review the capabilities of the specified group of projectors, navigate to **Main Menu>Configuration>ArrayLOC>ArrayLOC Status**.

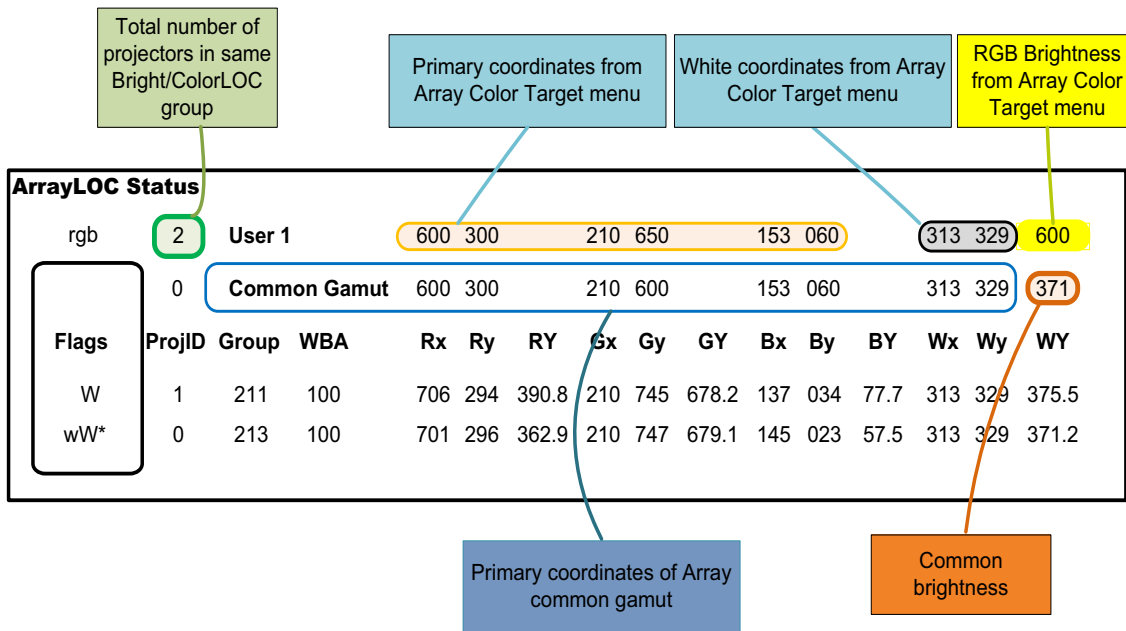

Figure 3-19 Array Status

The array status window includes the following information:

- The target gamut and calculated common gamut are shown in the same format as the projector data below. For the common gamut, if it is smaller than the target gamut, this is indicated in the flags column with **< Target**.
- The **Flags** column uses several characters to identify projectors within the array:
  - The least red projector is identified with a lowercase *r*.
  - The least green projector is identified with a lowercase *g*.
  - The least blue projector is identified with a lowercase *b*.
  - The dimmest projector is identified with a lowercase *w*.
  - The projector with white brightness capability less than Target brightness is identified with an uppercase *W*.

Any projector with broadcast mode enabled is identified with an asterisk \* if broadcasting to its Bright/Color group.

- The **Proj ID** column shows the projector array ID.
- The **Group** column shows the projector Bright/Color group #.
- The **WBA** column shows the projector white brightness adjustment.
- The **Rx**, **Ry**, and **RY** columns show the projector red CIE 1931 x, CIE 1931 y and CIE 1931 Y capability. The Y capability is the product of the projector Y grossed-up intensity and its current red duty cycle on time.
- The **Gx**, **Gy**, **GY**, **Bx**, **By**, and **BY** columns show the projector green and blue capability.
- The **Wx**, **Wy** and **WY** show the projector white capability. The projector white capability is calculated as the sum of the red, green and blue capability, scaled by the projector current duty cycle.

**Array Status Filter**

Use this option to specify which projectors are included in the ArrayLOC Status report.

- **Group, Min Capability** includes projectors in the array that meet targets.
- **Group** includes all projectors in the ArrayLOC group.
- **None** includes all the projectors detected in the ArrayLOC network.

**ArrayLOC Configuration**

• **ArrayLOC Network**

Select the projector-to-projector communication network configuration for all Ethernet messages related to ArrayLOC functions, including ArrayLOC messages and BCLOC messages.

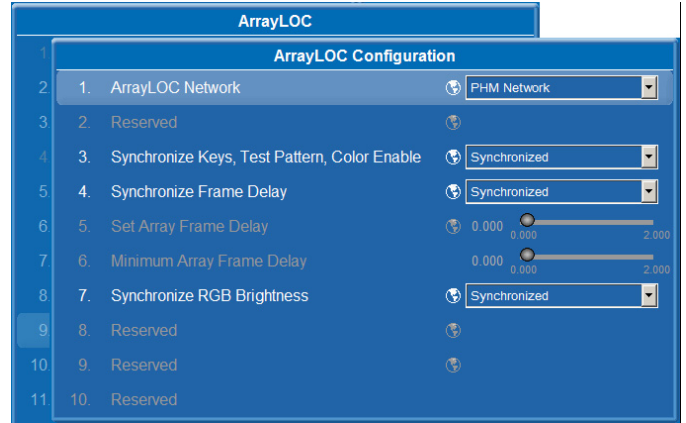

- **EM Network:** All Ethernet messages related to ArrayLOC flow through the EM Network port of the PHM.

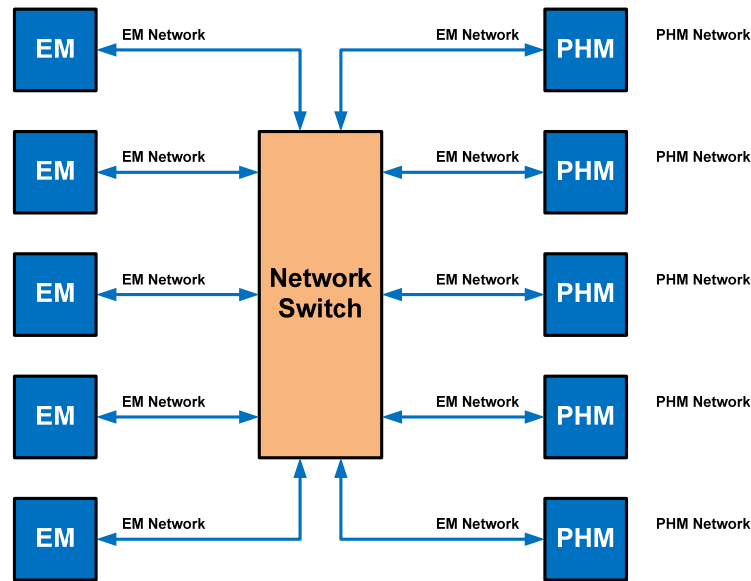

Figure 3-20 Projectors in an EM Network

- **PHM Network:** All Ethernet messages related to ArrayLOC flow through the PHM Network port of the PHM.

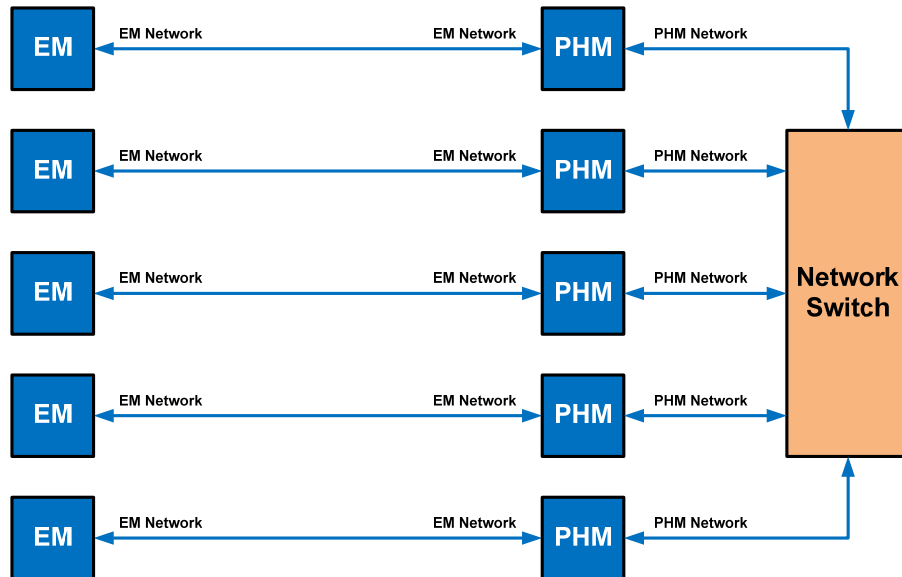

Figure 3-21 Projectors in a PHM Network

### Synchronize Keys, Test Pattern, Color Enable

Use the **Synchronized** option to set the projector to listen for remote keystrokes through the ArrayLOC network and the master projector. All synchronized projectors respond to the same keystrokes. Double key strokes may not register correctly, use alternate key commands instead.

A synchronized projector automatically starts listening to its IR receiver if the master projector becomes unavailable, for example if it goes into standby mode.

You can override the key synchronization by using the Proj key and projector address to communicate with a specific projector, or you can use a wired remote with a specific projector.

**Independent** indicates that the projector listens to its own IR remote receiver. It is the default option. Change this setting for each projector individually.

**NOTE:** *ArrayLOC network communication overrides RS-232 serial communication for keys.*

### Synchronize Frame Delay

Use the Synchronized option to synch the frame delay on all the synched projectors in the ArrayLOC group. Set the delay value in **Set Array Frame Delay**. **NOTE:** *To use this synchronization feature, set FrameLocking to FrameLOCK. See [Frame Locking on page 3-29](#).*

**Independent** is the default option. Change this setting for each projector individually.

### Set Array Frame Delay

This option indicates the current frame delay for all the synched projectors in the ArrayLOC group. Use this control on the master projector to adjust the frame delay for the synched projectors in the ArrayLOC group. Set the value equal to or higher than the reported **Minimum Array Frame Delay** value. Setting the value lower than the reported minimum may result in tearing artifacts.

**Minimum Array Frame Delay**

Indicates the largest minimum frame delay reported for the ArrayLOC group. The value is the largest of the reported minimum frame delay required to render the display without tearing artifacts on each projector in the ArrayLOC group.

**Synchronize RGB Brightness**

Use the Synchronized option to synch the RGB brightness for all the synched projectors in the ArrayLOC group.

Change this setting for each projector individually. **Synchronized** is the default option.

**RGB Brightness Target**

Use this option to adjust the target brightness for all projectors in this array.

**RGB Brightness**

Use this option to adjust the brightness of the projector array as a percentage of the target brightness.

**Managing Colors with ArrayLOC**

Mirage WU-L projectors use ArrayLOC to display a reasonably saturated gamut at the maximum brightness that all the projectors in the array can support. ArrayLOC monitors the projector array and adjusts settings automatically.

To manage color using ArrayLOC:

- [Take Control of the Array on page 3-55](#)
- [Adjust Projected White and Primary Colors for the Array on page 3-56](#)
- [Fine-tune Whites, White Brightness, or Primary Colors on page 3-57](#)
- [Fine-tune Projector Colors With a Color Meter on page 3-58](#)

**NOTE:** *ArrayLOC is enabled by default.*

**Take Control of the Array**

To make color adjustments across the array, you must make the projector you are working with the master projector.

1. On the projector you want to work with, access the ArrayLOC menu: **Main Menu > Configuration > ArrayLOC.**
2. Check **Synchronize to This Projector.**  
 The current projector becomes the master projector. Changes you make in the **Array Color Target** or **ArrayLOC Configuration** menus on the master projector are broadcast to the other projectors in the array.

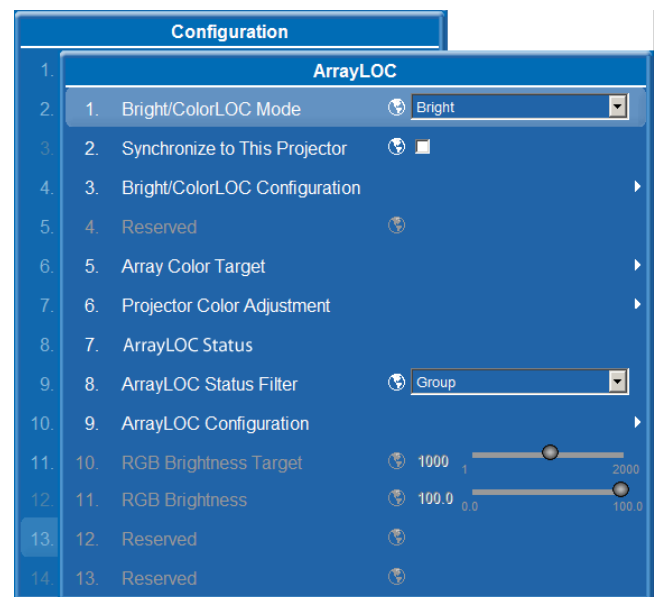

### Adjust Projected White and Primary Colors for the Array

User-defined target color spaces allow color primaries and white points to be adjusted independently. For example, you can select the target color space User 1, copy the values from the target color space Factory, leave the color primaries, and adjust only the white point. All the settings for a user-defined color space are editable.

1. Navigate to **Main Menu > Configuration > ArrayLOC > Array Color Target**.
2. In **Target Color Space**, select one of the **User** settings to modify.

**NOTE:** *To use another color space as a starting point, select a source color space from the Copy Color Space From list. When using Maximum as a starting point, the values reflect a color space larger than capable for the best array color saturation. The values may not reflect real-world colors.*

3. Check both **Auto Color Enable** and **Test Pattern Enable**, the system (background) color changes to the target color being adjusted (for example, Target Red x invokes a red background). All other menu options change the system color to white as long as Test Pattern Enable is checked.
4. Adjust the color primaries (for example, Target Red x and Target Red y) for the color space.
5. To adjust white in the image, select a **User White** item (1 to 4).
  - Adjust **Target White x** and **Target White y** values, or
  - Check the **Set White to Color Temperature** box and set the **White Color Temperature** value to any value between 3200 and 9300°K.
6. To adjust the target brightness for the array, adjust **RGB Brightness Target** on the master projector. For maximum brightness, set the value to a large number, such as 1000.
7. If the array appears matched across all projectors for color and brightness, color setup is complete, otherwise see [Fine-tune Whites, White Brightness, or Primary Colors on page 3-57](#).

**NOTE:** *Array Capability expresses the common gamut red, green, blue and white values of the current projector as a percentage of the array target color and brightness values (see Minimum Gamut, on page 3-47). If any of these values is less than 100, there is at least one projector in the array that cannot achieve target values. Reducing Target Color Space and RGB Brightness Target values in the master projector will bring the Array Capability values closer to 100.*

**Fine-tune Whites, White Brightness, or Primary Colors**

**Projector Color Adjustment** lets you fine-tune color or brightness for individual projectors that don't quite match the array. For more information, see *Projector Color Adjustment, on page 3-41*.

These steps outline color adjustments using projector color settings until the colors appear to match the rest of the projectors in the array. Color adjustments are evaluated by eye. A color meter can help determine the change required, but the results are still evaluated by eye. For information about using the color meter with this procedure, see *Fine-tune Projector Colors With a Color Meter on page 3-58*.

1. Navigate to **Main Menu > Configuration > ArrayLOC > Projector Color Adjustment**.
2. Projector Color Adjustment settings are specific to each color space. To use existing fine-tuning adjustments as a starting point, select a tuned color space from **Copy Adjustments From**.
3. Check both **Auto Color Enable** and **Test Pattern Enable**, the system (background) color changes to the target color being adjusted (for example, Target Red x invokes a red background). All other menu options change the system color to white as long as Test Pattern Enable is checked.
4. Navigate to **Main Menu > Configuration > Communication**. Note the IDs of the projectors you want to fine-tune.
5. To adjust white color and brightness settings (repeat for each projector that needs adjustment):
  - a. Press PROJ, <PROJECTOR ID > on the remote. The remote directs commands to the specified projector only.
  - b. Use the **White Brightness Adjustment** to roughly match the white brightness of the array. A higher value makes the projector image brighter.
  - c. Adjust the **Red Part of White**, **Green Part of White**, and **Blue Part of White** to match the white color to other projectors in the array.
  - d. Readjust the **White Brightness Adjustment** control if matching white colors revealed mismatched white brightness.
6. Navigate to **Main Menu > Configuration > Communication**. Note the IDs of the projectors you want to fine-tune.

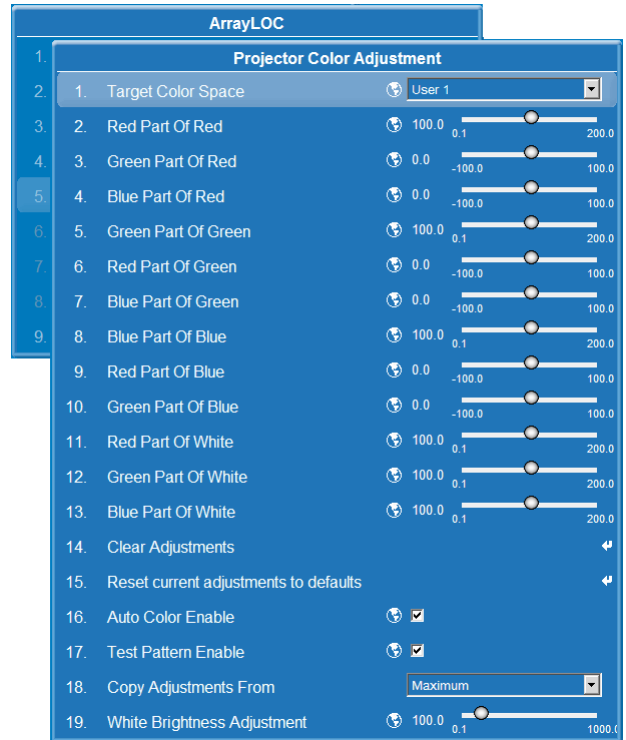

7. To adjust color primary settings (repeat for each projector that needs adjusting):
  - a. Press PROJ, <PROJECTOR ID > on the remote. The remote directs commands to the specified projector.
  - b. Adjust the **XXX Part of YYY** controls where and YYY is the color being adjusted, and XXX and YYY are not the same color (ie. non-dominant colors). Negative values for the non-dominant colors are permitted. Adjusting **XXX Part of XXX** adjusts the color’s brightness and affects the color of white.  
 Example: If the blue primary color does not match. Use the **Red Part of Blue** and **Green Part of Blue** controls. Negative values will increase the saturation of the blue. Values between -15 and +3 work well.  
**NOTE:** For information about using a color meter with this procedure, see [Fine-tune Projector Colors With a Color Meter on page 3-58](#).
8. Repeat steps 6 and 7 until all the primary colors are matched.
9. After adjusting the primary colors, verify that the white color and brightness still match. Repeat the process if necessary.

**Fine-tune Projector Colors With a Color Meter**

To use a color meter for projector color adjustments, follow the instructions in [Fine-tune Whites, White Brightness, or Primary Colors on page 3-57](#), but use a color meter for the XXX Part of YYY adjustments.

1. To note the xy color values reported for the common gamut, navigate to **Main Menu > Configuration > ArrayLOC > ArrayLOC Status**. For example, see **Figure 3-19**.
2. Measure the projected primary color with the meter and compare the metered values to the common gamut values.
3. Use the adjustment guide to determine how to adjust the Projector Color Adjustment values to correct the differences. The adjustment guides are color coded. The suggested corrections are also color coded, and reflect the direction of the change, + or -. For example, if the measured red is 660, 325 and the Common Gamut value is 640, 330 then the measured x is high (High X) while the measured y is low (Low Y). The corresponding quadrant of the RED guide indicates +G (increase green) to correct the mismatch with other projectors.

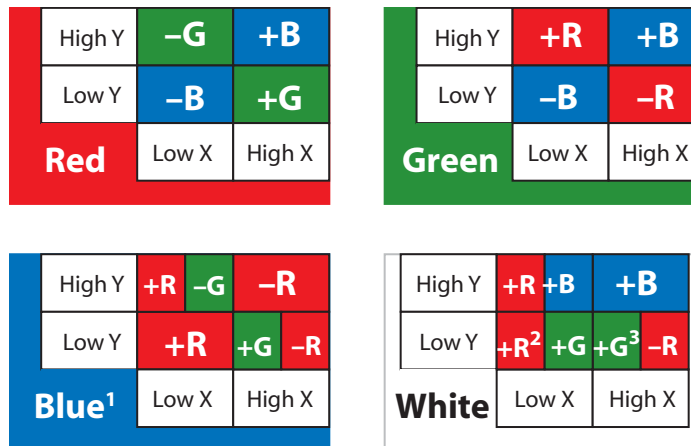

Figure 3-22 Red, Green, Blue, and White Color Adjustment Guides

<sup>1</sup>Some corrections require both red and green adjustments.

<sup>2</sup>Alternative: decrease blue (-B) instead of increasing red and green.

<sup>3</sup>Alternative: increase blue (+B) and increase green (+G) instead of decreasing red, and increasing green.



### 3.4.6 Main Menu > Status

Access the read-only **Status** window from the Main menu. It lists a variety of details about the standard and optional components detected in the projector. See the **Status** menu for versions of hardware and software installed, the hours logged in total and for a specific period (such as a rental period), and for your projector model name and serial number. In addition, the **Status** menu identifies the current channel, its location, its frequencies and other details.

### 3.4.7 Main Menu > Secondary Input & Switching

Use the **Secondary Input & Switching** menu to enable and define how you want to use the secondary input.

**NOTE:** *To control the primary image, access all picture controls through the Main menu.*

The following section describes each option found in and stemming from the **Secondary Input & Switching** menu.

#### Main Input

From the list of active Inputs, select one to be used as the Primary or Main image.

#### Secondary Input

From the list of active inputs, select one to be used as the secondary.

#### Swap Main & Secondary inputs

Toggle the current secondary input's relationship so that the primary (Main) input becomes the secondary, and the secondary input becomes the primary.

**NOTE:** *There may be a slight delay when swapping the Primary and Secondary images.*

#### Secondary Size & Position

Most of the controls adjust the secondary image in the same fashion as the main image controls, see [3.4.2 Size and Position Menu on page 3-16](#).

#### Keep Aspect On Auto Setup

Ensures that Auto Setup for any source will maintain the input aspect ratio when the default size is calculated. If disabled, and the source is not a special case, the video source where a default stretch is defined, the source is scaled to fit the platform.

#### Secondary Blanking

The controls adjust the secondary image in the same fashion as the main image controls, see [Blanking on page 3-19](#).

#### Secondary Image Settings

The controls adjust the secondary image in the same fashion as the main image controls, see [Image Settings Menu on page 3-19](#).

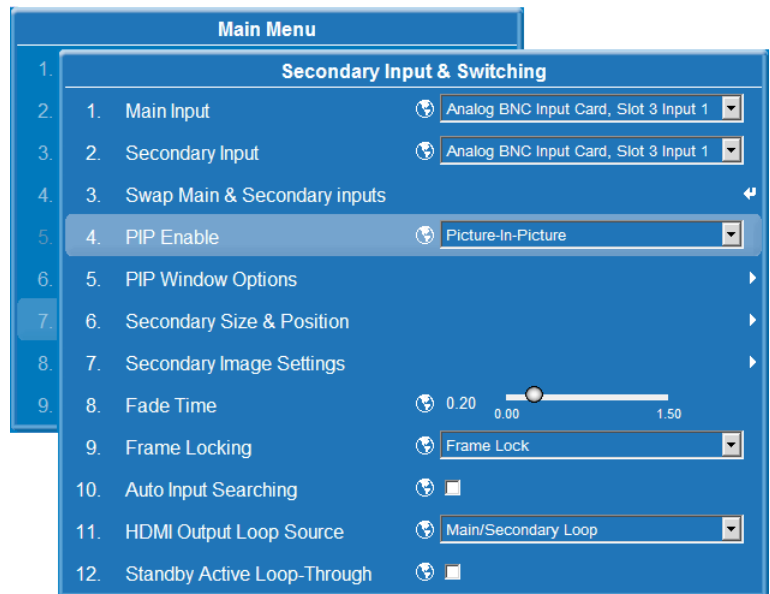

### Secondary Video Options

The controls adjust the secondary image in the same fashion as the main image controls, see [Video Options Menu on page 3-20](#).

### Secondary Input Levels

The controls adjust the secondary image in the same fashion as the main image controls, see [Input Levels Menu on page 3-22](#).

### Secondary Advanced Image Settings

The controls adjust the secondary image in the same fashion as the main image controls, see [Advanced Image Settings Menu on page 3-25](#).

### Fade Time

Controls the amount of time (in seconds) it takes to fade between images on a source switch. It also fades in the secondary image and OSD if possible.

### Frame Locking

Enable or disable Frame Lock. When set to Frame Lock, output image frames are locked to the input if possible. When Locked, the output is always locked to the primary input. When set to **Free Run**, sets the output to the **Free Run Frequency** value. The projector will not display 3D content when it is set to **Free Run**.

### Auto Input Searching

When enabled, the system will continually search for the next valid signal when no signal is present or when loss of sync occurs on the current user-selected input. In the case of multiple signals to choose from, the order is based on slot, followed by inputs on that slot.

### HDMI Output Loop Source

This control is used to configure the HDMI output options. Selecting **Direct Loop** will directly pass-through the HDMI Input signals: on the same Twin HDMI Input Card, the Input1 signal is looped to Output1 and the Input2 signal is looped to Output2. Selecting **Main/Secondary Loop** will loop the main and secondary video to the outputs, regardless from which card these signals originate. The Main video signal is looped to Output1, and the secondary video signal is looped to Output2. Selecting **Disable** will shut OFF the HDMI outputs completely.

### Standby Active Loop-Through

Select the check box to allow an incoming signal to be passed to the Output ports of the HDMI Input module when the unit is in **Standby** mode.

## 3.4.8 Main Menu > Language

Use this drop-down list to select a language for the menu system.

## 3.4.9 Main Menu > Test Pattern

Steps forward through all internal test patterns. After stepping past the last test pattern, you will return to the current input.

### 3.5 How Color Settings Interact in a Mirage WU-L Array

**Image Settings > Color Space** tells the projector how to interpret video data coming in. See [Color Space on page 3-20](#).

**Image Settings > Advanced Image Settings > Color Settings** adjusts the color temperature. Use ArrayLOC color and color temperature settings instead. When enabled, ArrayLOC overrides the settings on the Color Settings menu. See [Color Settings on page 3-27](#).

**Configuration > Geometry & Color > Manual RGB Adjustment** is the manual way to set the levels of each LED. These adjustments are available when ArrayLOC is OFF or set to Fixed mode. When ArrayLOC is set to Cool or Bright mode, LED levels are controlled by ArrayLOC function automatically.

**Configuration > ArrayLOC > Array Color Target** tells the projector what you expect to see on the screen. This is the recommended way to control the color space for the projector and array. See [Array Color Target on page 3-41](#). This menu is also available under Configuration > Geometry & Color.

**Configuration > ArrayLOC > Projector Color Adjustment** lets you adjust each projector output so that it represents the color target. Adjustments compensate for projector-to-projector differences and for the projection system as a whole, including loss of brightness or color shift due to lens, mirror, and screen. For example the mirror might not reflect blue 100 percent, or the screen might absorb more blue. You can measure the output at the screen with a color meter and use this option to increase the blue until you get the array color target value at the screen. See [Projector Color Adjustment on page 3-50](#). This menu is also available under Configuration > Geometry & Color.

**Configuration > ArrayLOC > Projector Color Adjustment > White Brightness Adjustment** lets you turn the brightness target adjustment into a meaningful number, for example a number that relates to Ft-L. See [6.6.10 Array Status Decoder & Setting the RGB Brightness Target Unit](#) in the troubleshooting section.

### 3.6 3D

The Mirage WU-L projector is capable of displaying stereoscopic 3D video sources. The Mirage WU-L relies on additional hardware, such as stereo emitters and glasses, to complete the display system.

Images generated from a stereo 3D-video source consist of a series of images (*frames*) that alternate quickly between two slightly different view points, corresponding to our left and right eyes. When these frames are displayed fast enough and viewed with special stereo glasses synchronized to the left/right (L/R) changes, the resulting image appears with the same depth and perspective that is sensed in the real world.

**NOTE:** *The type of special glasses can be active stereo or passive stereo glasses depending on the type of stereo controllers and screen used.*

#### 3.6.1 Requirements

Stereo 3D applications require a stereo 3D-capable source, special hardware/software setups described below, and the projector's *3D Settings* menu option to control the projector's processing, synchronizing and displaying of your stereoscopic 3D source material.

##### Hardware

- Christie Mirage *WU-L* projector.
- Christie GPIO 3D Stereo Sync Cable (required for Mirage UI-L projectors; ensures minimum frame delay). This GPIO cable is standard with all Mirage WU-L projectors.

- A source, usually a computer with a stereo 3D graphics card capable of displaying progressive scan (alternating frames) of OpenGL quad buffered stereo 3D applications. Suggested video cards include ATI or NVIDIA.
- Emitter for controlling active shutter glasses.
- An appropriate qualified device that mounts in front of the lens of the projector that will process the light from the lens into a passive polarized light. Contact your Immersive dealer for more information.

### Software or content

- Any 3D computer software that supports active or sequential 3D stereo on a supported computer/graphic card.
- A video stream from video source that has been prepared to be sequential content. The Mirage WU-L also supports stereo signals prepared on either a compatible Dual or Single link HDS/SDI format. **NOTE: The VGA port does not support 3D.**
- Frame locked Passive sources are also compatible with the Mirage WU-L with the appropriate primary and secondary input card.

### 3.6.2 Connecting the GPIO 3D Stereo sync cable

This GPIO cable provides the means for synchronizing the various components in your 3D system. Your source, projector display output, and emitters or 3D passive filter system can then operate together with precision to minimize cross-talk and color artifacts. Connect as shown below in **Figure 3-23**.

**NOTE:** For Mirage WU-L, inputs A and B are not required, but recommended to ensure that stereo is configured correctly, especially for multiple projector setups.

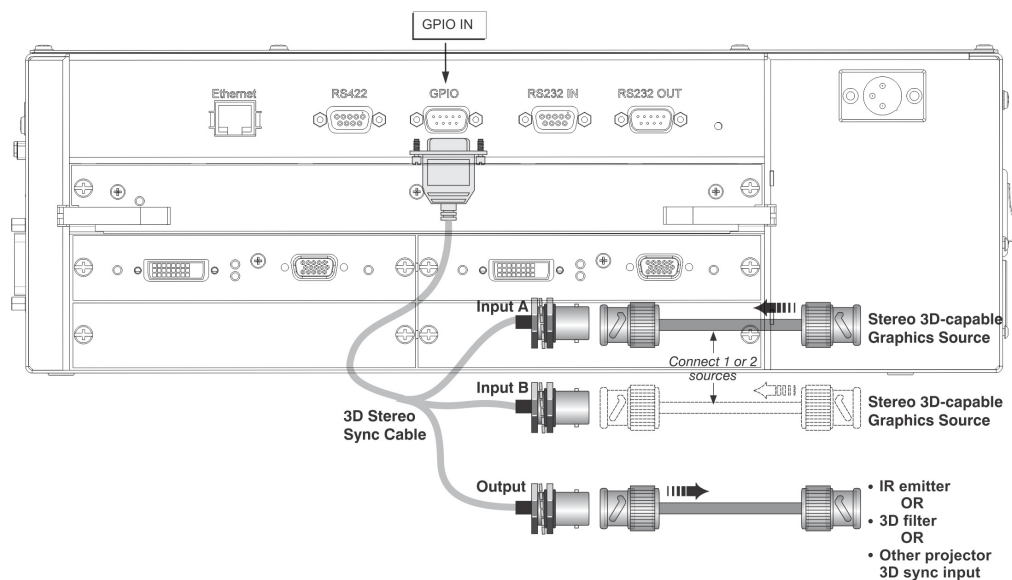

Figure 3-23 Mirage GPIO 3D Stereo Sync Cable

#### Connecting Two Stereo 3D Sync Inputs (Recommended for multiple sources)

Connect your video card's stereo 3D sync cable to either Input A or either Input B on the GPIO 3D Stereo Sync Cable. These inputs are provided to allow you to connect two different Stereo 3D sources and conveniently switch the display back-and-forth between them.

### Connecting One Stereo 3D Sync Output

Connect the GPIO 3D Stereo Sync Cable output to your stereo 3D sync emitter or 3D passive filter system, PZE device. The L/R switching of the device can then be synchronized according to the controlling signal of choice—either the source input signal or the projector’s internally generated signal—as set in the projector’s 3D Settings menu.

### 3.6.3 Active and Passive Stereo 3D Configurations

Typical hardware configurations for active and passive Stereo 3D systems are shown in **Figure 3-24** and **Figure 3-25**.

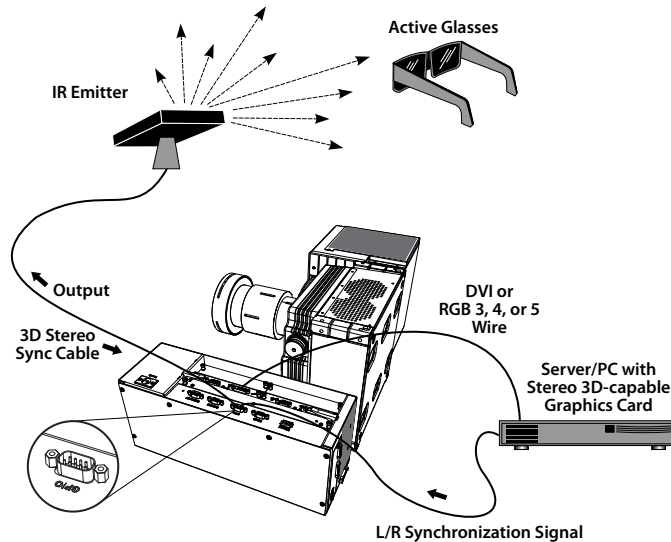

Figure 3-24 Mirage WU-L: Typical Stereo 3D Configuration: With Active Glasses

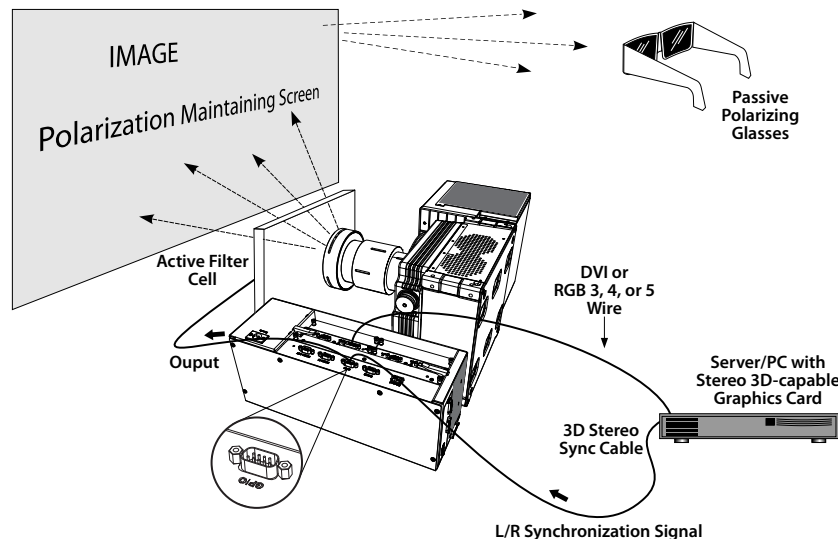

Figure 3-25 Mirage WU-L: Typical Stereo 3D Configuration: With Passive Glasses

**Appropriate Stereo 3D Source:** Use stereo 3D application software with your 3D video source (usually a workstation or PC). The source must also provide a separate stereo 3D synchronization signal that precisely controls when left/right fields are visible through the viewer’s glasses. This separate signal is usually provided using a VESA 3 pin stereo port.

**IR Emitter/3D Passive Filter System:** In response to an incoming sync signal, the emitter emits L/R infrared signals to a receiver in active 3D shutter glasses, causing the L/R shutters to alternately open and close for active stereo 3D applications. Likewise, a 3D passive filter system placed in front of the lens responds to an incoming sync signal and alternately polarizes the L/R frames viewed with passive glasses for active stereo 3D applications. Connecting one of the GPIO 3D Stereo Sync Cable outputs to an emitter/3D passive filter system allows you to synchronize your stereo 3D display with the glasses.

**Glasses (Active/Passive):** Active glasses differ in speed and performance. Consult the documentation for your glasses and keep their specifications in mind when configuring your source signal. The input signal must be optimized for the available shutter speed to prevent obvious “ghosting” of image content (known as cross-talk in stereo 3D applications) and other more subtle color artifacts. Such problems indicate that the eyes are detecting portions of the opposing frame due to an “out-of-sync” system, and can occur in either active or passive stereo 3D configurations. Adjust the Dark Interval setting to reduce ghosting.

In the 3D Settings menu, the correct “3D Stereo Sync Delay” setting should help to synchronize glasses with the displayed images. **NOTE:** *In a passive system, where glasses do not have shutters and instead depend on the speed and accuracy of the 3D passive filter system, the signal must be synchronized to the projector via the GPIO 3D Stereo Sync Cable.*

### 4.2 3D SETTINGS

Use the options in the 3D Settings menu to make the timing adjustments necessary for realistic simulation and 3D images..

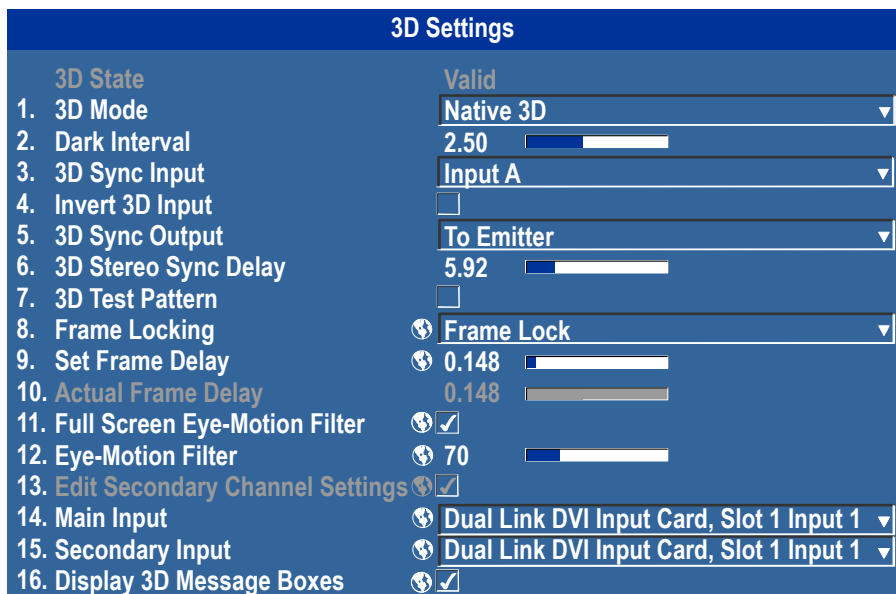

**3D State:** Informs you what state the projector is in: Off, Missing Secondary Signal, Not Frame Locked, Secondary Frequency Mismatch, High Bandwidth Not Supported, Stereo Sync Not Detected, Stereo Sync Invalid, and Invalid Frequency. **NOTE:** *This is read only.*

**3D Mode:** Select the mode of your 3D operation.

- **Off:** 3D operation is disabled.
- **Native:** All content is shown at a native frame rate of 96 - 120 Hz input and output.
- **Frame Doubled 3D:** 3D Content from a single 48-60Hz signal (24/30Hz per eye) are displayed twice to provide a 3D content to be viewed at 96-120Hz.
- **Dual Input 3D:** Content from two independent 48-60Hz ‘passive’ frame locked sources are interleaved into a native 96-120Hz native frame rate. This requires an optional input module and both signals must be from the same signal type.

**Dark Interval:** Artificially increases the amount of dark time between displayed frames for stereoscopic 3D images. Higher settings provide more time for shutters in 3D glasses to open and close, ensuring that each eye sees the full display intended for it. Symptoms of cross talk or color artifacts can indicate the need for adjustment. The Dark Interval range of adjustment depends on the vertical frequency of your source-the higher the frequency, the smaller the range. Default setting is 2.5mS.

**3D Sync Input:** The 3D sync signal is generated by the 3D source to insure left/right eye content is synchronized to the projector and you. The projector has the ability to physically connect to two different sources. Ensure that the correct 3D sync input is selected (either Input A or Input B) with each 3D signal source. If none/internal is selected the projector will generate the sync internally and content will be displayed; however, there is a 50% chance that the content will be displayed with the left/right eyes swapped (from the remote, press FUNC 6-9 to swap the eyes). **NOTE:** *This function is not used in Interleaved 3D mode. Each eye receives a selected input and no 3D sync input is required.*

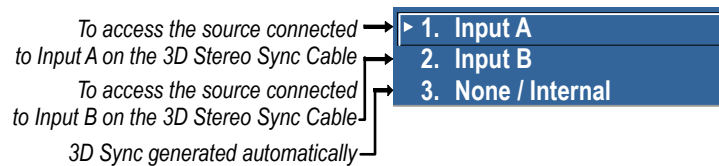

**3D Sync Output:** This option defines whether the 3D Sync is output and controls how it is processed. It is only valid when an optional cable is used to connect stereo 3D signals to the projector via the GPIO port. When there is no 3D signal, Sync Output should be 'Off'. Typically only the last projector in the 3D Stereo cable chain is connected to the emitter and should specify 'To Emitter'. All other projectors should select 'To Next Input' if other projectors are used in the chain.

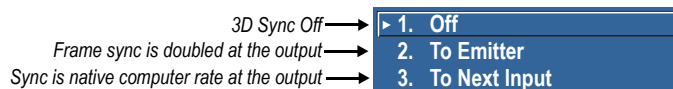

**3D Stereo Sync Delay:** Adjust the output 3D emitter delay (in milliseconds) to match the active glasses to the L/R frames of the projector. Proper adjustment of this delay will eliminate cross talk and odd colors caused by timing differences between the glasses and the projected image. Your specified delay is added after sync locking.

**3D Test Pattern:** Enables a 3D test pattern for diagnostics. The scrolling diagonal lines indicate how well left and right are synchronized. If ghosting is occurring the input may have to be switched or inverted. Adjustments to the emitter delay can also help correct the synchronization. To verify that your 3D is setup correctly, a small set of **Ls** will be visible when you close your right eye and a small set of **Rs** will be visible when you close your left eye.

**Frame Locking:** Enable or disable Frame Lock. When set to Frame Lock, if possible output image frames are locked to the input. When Locked, the output is always locked to the primary input and never the secondary image, when using Dual input 3D. Free Run sets the output to close to 60Hz for all sources. This control must be set to locked if a 3D-Stereo signal is used.



**Set Frame Delay:** Delays the output signal timing relative to the input signal timing by a fraction of a frame, and up to several frames. The minimum latency can vary based on the amount of scaling applied to the image. When using keystone or warping, an additional latency is required, depending on the amount of warp. The control is only available when the input signal is frame locked. In free run mode, or in cases where the signal cannot be frame locked, the minimum latency defined by the scaling and keystone/warp is applied to the signal.

**Actual Frame Delay:** Displays the actual frame delay reading.

**Full Screen Eye-Motion Filter:** Check this control to apply the Eye-Motion Filter to the entire screen, rather than applying just to the edge blending regions. Helps with posterization effects, sometimes seen in color ramps when viewing stereoscopic images.

**Eye-Motion Filter:** Adjust this filter to reduce saccadic eye-motion artifacts, sometimes noticeable in edge blending regions. Too much filtering may result in loss of detail. For best results, adjust this setting while positioned at the nominal screen-viewing distance.

**Edit Secondary Channel Settings:** When using Dual Input 3D, this allows you the option to independently control primary and secondary channel settings, or to use the same setting for both links. By default, this control is unchecked, meaning any settings applied to the primary input will also be applied to the secondary input. In this case, the secondary channel settings cannot be set. When checked, the secondary channel settings become editable.

**Main Input:** Select an input from the drop-down list. Refer to [2.3 Connecting Sources, on page 2-8](#) for more details.

**Display 3D Message Boxes:** Enable/Disable message boxes that are triggered by 3D setup. **NOTE:** *No message box is shown in “Off” and “Valid” state.*

### 3.6.4 Example of 3D Multiple Display Setup

The following instructions is an example of a multiple display setup or refer to Figure 26 Example of 3D Multiple Display Setup.

1. Setup the projector’s warp and blends.
2. If necessary, shift or scale your image to fit the display.
3. Set all projectors to the largest minimum Frame Delay value that the worst case projector in the array can achieve.
4. Enable 3D mode on all projectors. Using the remote >**Main Menu**>**Image Settings**>**Advanced Image Settings**>**3D Settings**
5. Set all projectors 3D Sync Output to “**Next Projector**” with the exception of the last projector; select “**To Emitter**.”
6. Connect the PC emitter sync to either **Input A** (or B) on the 3D dongle.
7. Connect the output from the 3D dongle in the first projector to **Input A** (or B) on the next projector in the array.
8. Repeat the same procedure to all projectors except the last projector in the array. Route the Sync output from the 3D dongle to the emitter. **NOTE:** *For the last projector, route the sync input.*



9. If your emitter has a reverse setting ensure it is set to the Off position.
10. Set all projectors to **3D Sync Input A** (or B) depending on your selection in steps 6 & 7.
11. Apply the 3D test pattern to all projectors.
12. Put on your 3D glasses.
13. When 3D is setup correctly, a small set of L's are visible by closing your right eye and a small set of R's are visible when closing your left eye.
14. If necessary, adjust the dark interval settings until the test pattern sees the least amount of ghosting for each projector.
15. Adjust the 3D Sync Delay on the last projector in your array to match the optimal sampling point for the glasses being used. **NOTE:** *The default auto setup value is typically good for all glasses.*
16. Turn off the 3D test pattern on each projector. Your 3D content should look optimal.

### 3D SETUP

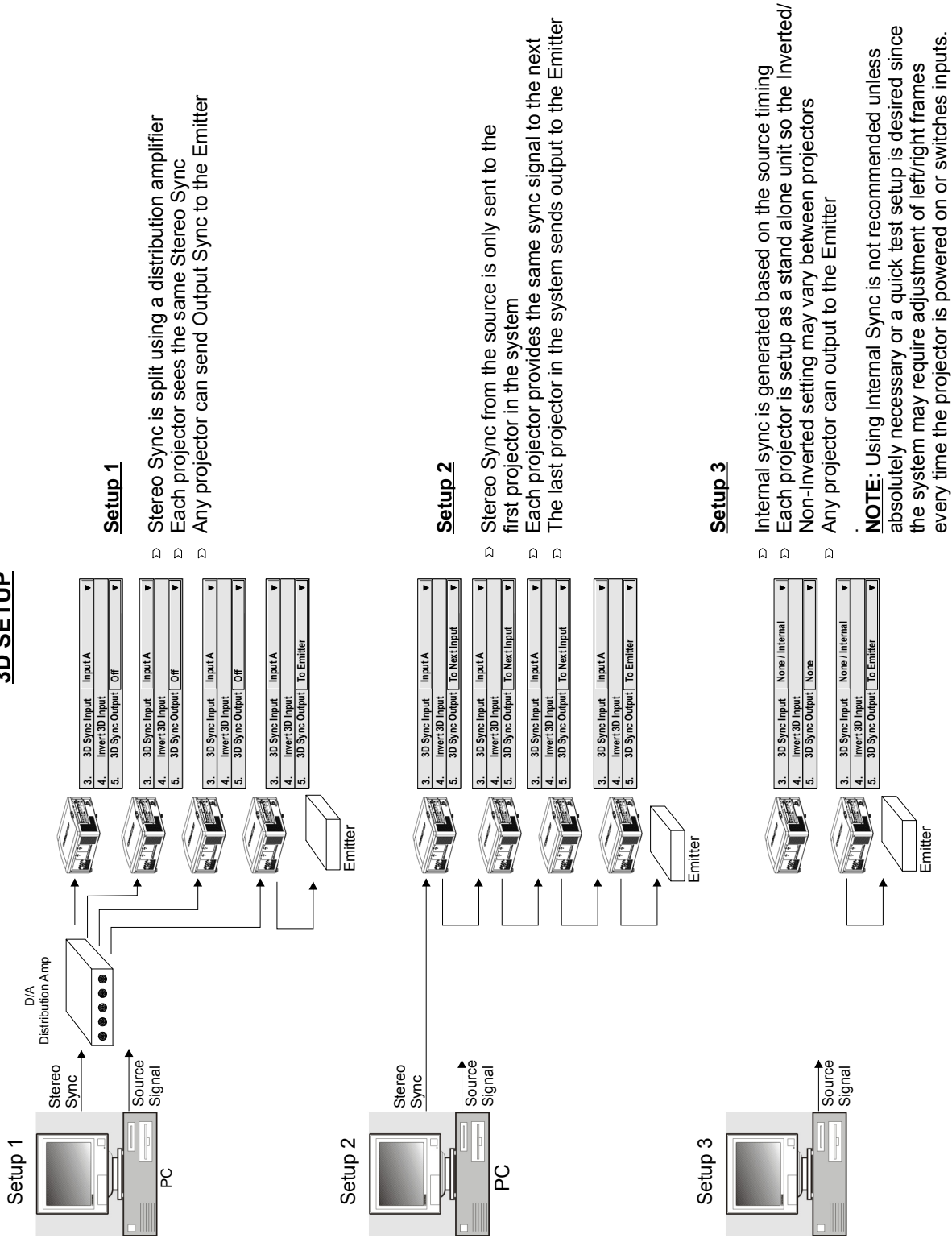

Figure 26 Example of 3D Multiple Display Setup

# 4 Menu Tree



### 4.1 MENU TREE



### 4.1.1 MENU TREE CONTINUED - CONFIGURATION

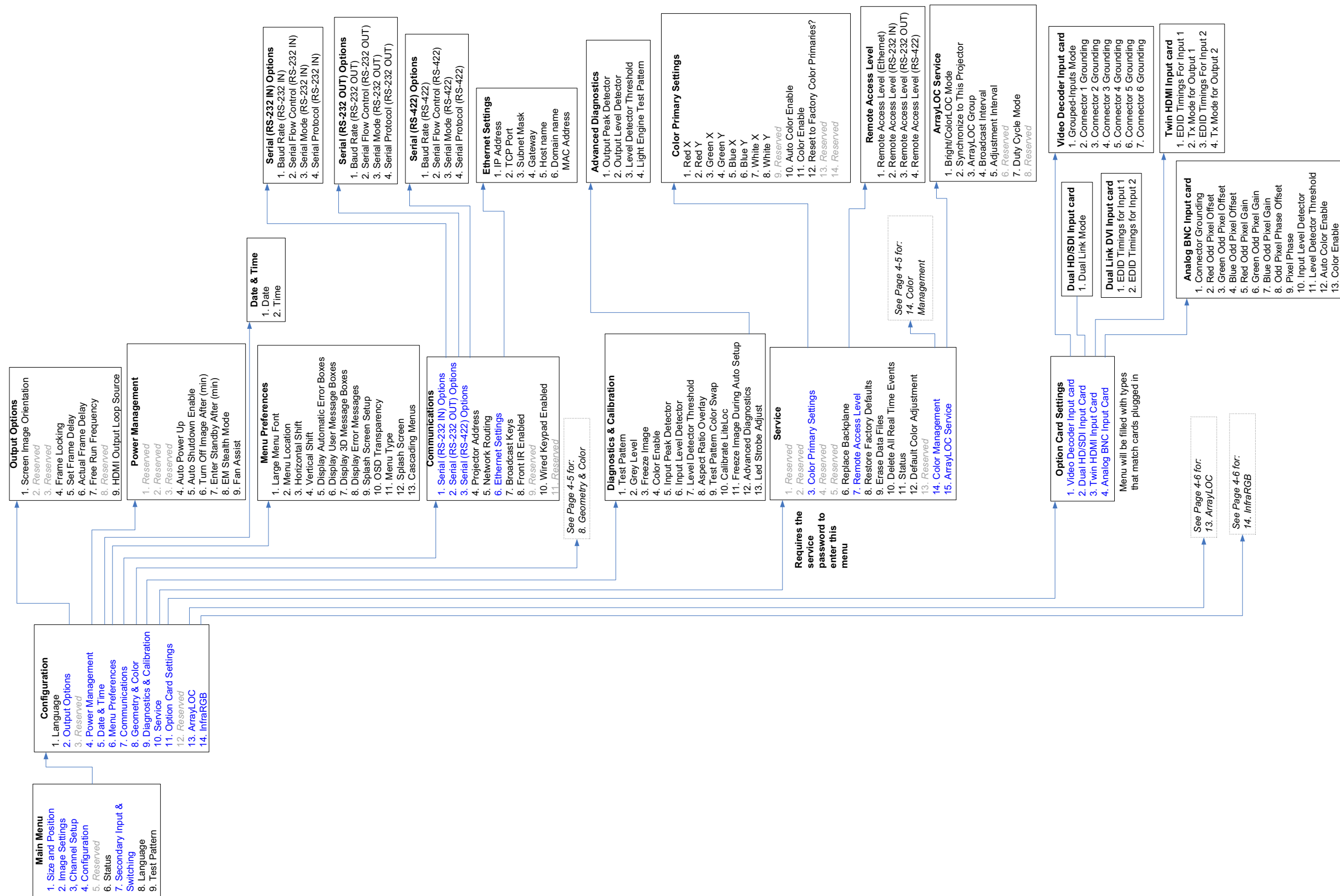

4.1.2 MENU TREE CONTINUED - GEOMETRY AND COLOR

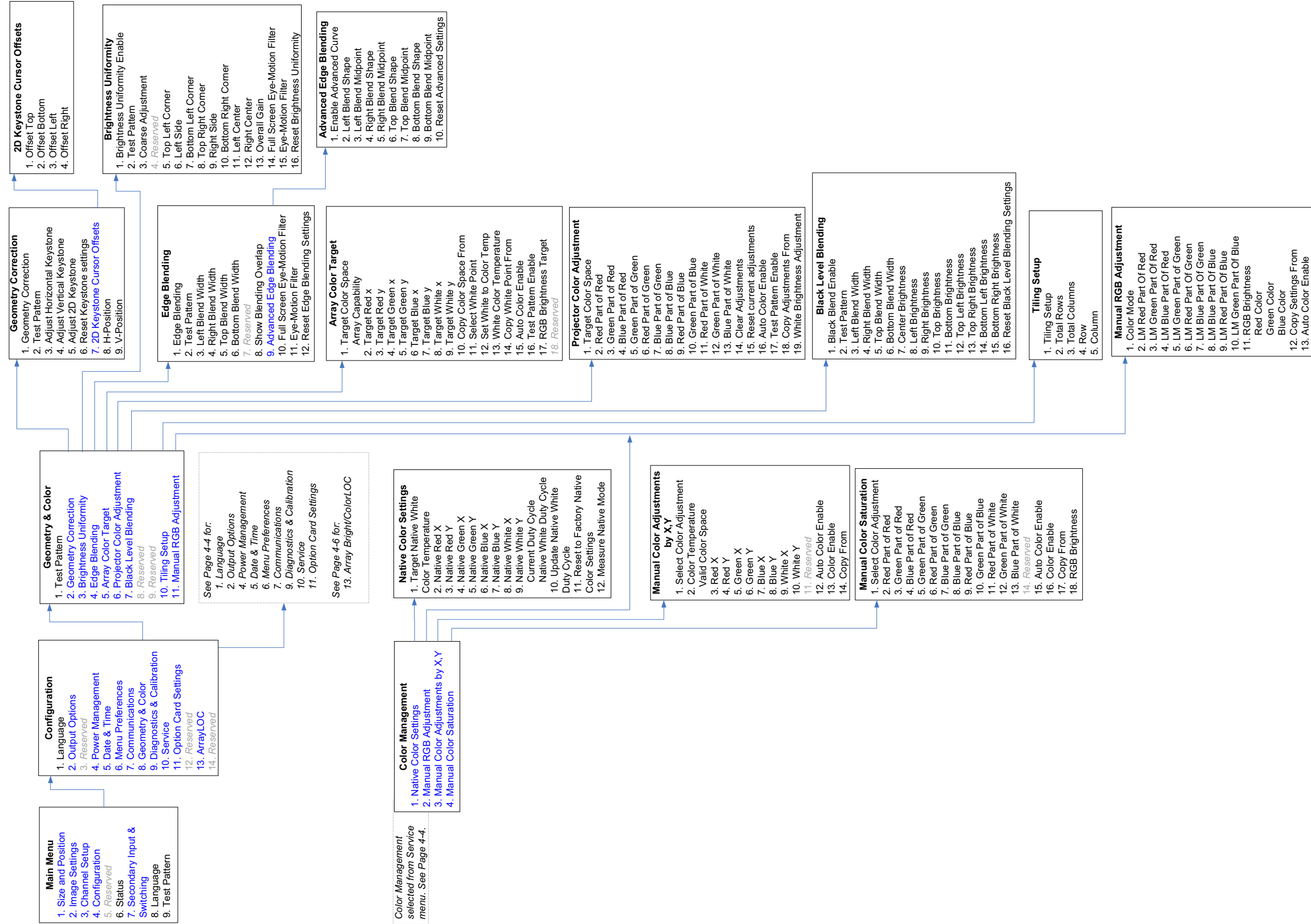

4.1.3 MENU TREE CONTINUED - ARRAYLOC

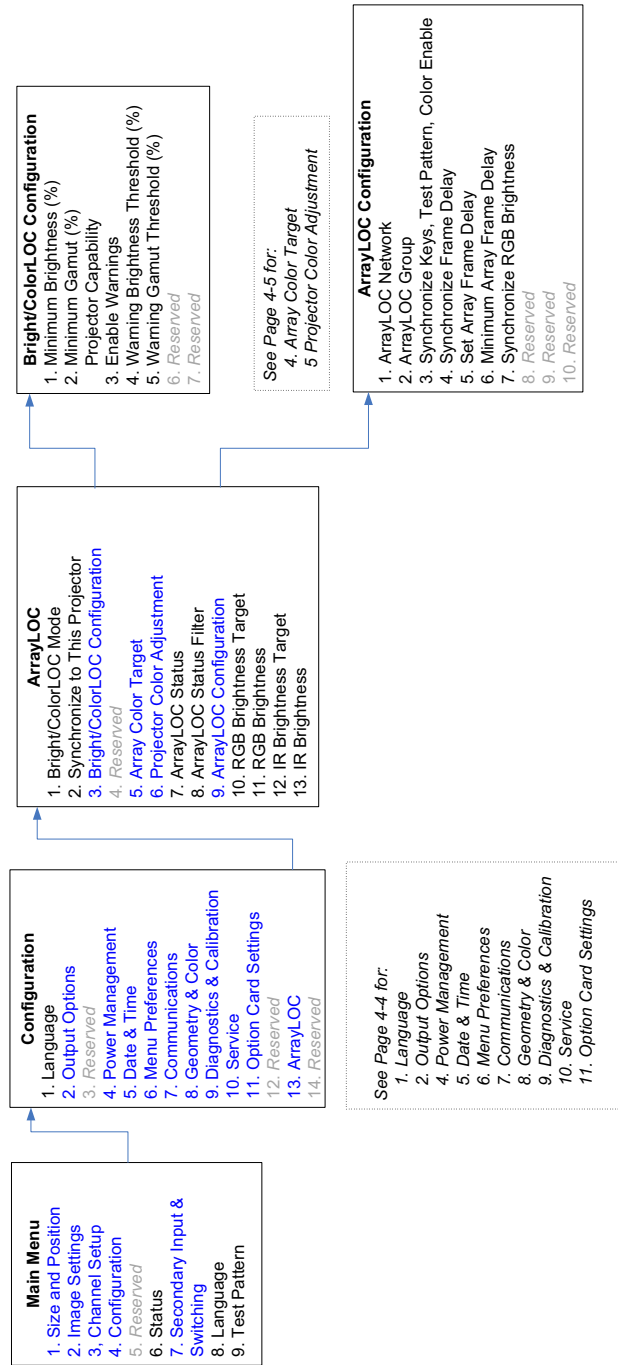



# 5 Maintenance

## 5.1 Safety Warnings and Guidelines

Installers, service trained operators and all users must maintain a safe operating environment at all times. Read this section in its entirety and understand all warnings and precautions before operating the projector.

## 5.2 Maintaining Proper Cooling

Air vents are located around the projector to keep it at a consistent operating temperature. Make sure that the empty space around these vents (“stay out zone”) is within the limits specified in [Section 7 Specifications](#). This will prevent the blockage of air flow and prevent overheating. The projector is equipped with active thermal monitoring. The speed of the cooling fans adjust to the projector temperature.

- Do not put the projector on a radiator or heat register.
- Do not put the projector in an enclosure without correct ventilation.
- Do not put objects into the ventilation openings of the projector. They can touch dangerous voltages or short-circuit components resulting in a fire or shock hazard.
- Do not spill liquids into the projector. If a spill occurs, immediately disconnect the projector and have it serviced by a Christie accredited service technician.

## 5.3 Maintenance and Cleaning

The projector is an international regulatory agency approved product designed for safe and reliable operation. It is important to acknowledge the following precautions while operating the projector to assure complete safety at all times.

### 5.3.1 WARNINGS AND SAFETY GUIDELINES

**⚠ DANGER** Do not look directly into the projector lens. The high brightness of this projector could cause permanent eye damage. For protection, keep all projector shielding intact during operation.

**⚠ CAUTION** Always power down the projector and disconnect before servicing.

The projector is a class 2M source of visible and invisible LED radiation. Directly viewing the LED output with certain optical instruments (for example, eye loupes, magnifiers and microscopes) within a distance of 100 mm (3.94”) may pose an eye hazard.

### 5.3.2 LABELS AND MARKINGS

Observe and follow all warnings and instructions marked on the projector.



The exclamation point within the equilateral triangle tells the user of important operating and maintenance (servicing) instructions in the literature accompanying the projector.



The lightning flash and arrowhead symbol within the equilateral triangle tells the user of "dangerous voltage" not insulated within the projector's enclosure that is of sufficient magnitude to constitute a risk of electric shock.



The projector is a class 2M source of visible and invisible LED radiation. Directly viewing the LED output with certain optical instruments (for example, eye loupes, magnifiers and microscopes) within a distance of 100 mm may pose an eye hazard.

### 5.3.3 INSTRUCTIONS

Read all operating instructions prior to using the projector.

### 5.3.4 PROJECTOR LOCATION

Operate the projector in an environment that meets the operating range, specified in [Section 7 Specifications](#).

- Do not operate the projector close to water, such as near a swimming pool.
- Do not operate in extremely humid environments.
- Do not place the projector on an unstable cart, stand or table. A projector and cart combination must be used with care. Sudden stops, excessive force and uneven surfaces may cause the projector and cart combination to overturn.

### 5.3.5 SERVICING



All servicing must be performed by Christie accredited service technicians. Use replacement parts that are manufacturer-approved only. Use of any other part other than the ones specified by the manufacturer can result in fire, electric shock or risk of personal injury and irreparable equipment damage.

Do not service the projector while it is still connected. There are exposed voltages that could cause severe physical injuries and possibly death. Always disconnect the projector and wait 2 minutes to allow the power supply capacitors to electrically discharge before removing the projector covers.

If any of the following conditions exist, immediately disconnect the projector from the power outlet and consult a Christie accredited service technician.

- The power cord is damaged.
- The internal cooling fans do not turn ON when the projector is first powered up.
- Liquid is spilled into the projector.
- The projector is exposed to excessive moisture.
- The projector is not operating normally or performance has significantly deteriorated in a short period of time.
- The projector has been dropped or the shipping case (if applicable) is badly damaged.

**5.3.6 CLEANING AND MAINTENANCE GUIDE**

**⚠ CAUTION** The projector is a class 2M source of visible and invisible LED radiation. Directly viewing the LED output with certain optical instruments (for example, eye loupes, magnifiers and microscopes) within a distance of 100 mm (3.94”) may pose an eye hazard.

**Table 5.1 Maintenance Guide**

Part Description	Frequency	How to Clean
Projection Lens	As required	<p><b>Clean:</b> A small amount of dust on the lens has very little effect on picture quality. Clean only if absolutely necessary.</p> <p><b>To clean:</b> Moisten a clean (not-reused), lint-free cloth with a high-quality optical cleaning fluid. Wipe the cloth in a single continuous motion across the lens surface. Discard the cloth after cleaning. Use compressed air to remove any particles remaining on the lens.</p> <p><b>Do not</b> use a cleaning solvent that contains ammonia. Avoid lens contact with Xylene and Ether.</p>
External Projector Covers	As required	<p><b>Clean:</b> Clean dust from external covers using a clean, lint-free cotton cloth as required. <b>NOTE:</b> Before cleaning the modules, it is recommended that you install the lens cap. This will keep dust particles from settling on the glass surface of the lens.</p>

## 5.4 Light Module Replacement

**⚠ DANGER** Do not service the projector while it is still connected. There are exposed voltages that could cause severe physical injuries and possibly death. Always disconnect the projector and wait 2 minutes to allow the power supply capacitors to electrically discharge before removing the projector covers.

**⚠ CAUTION** Power should always be disconnected from the illumination module before servicing, to avoid the possibility of inadvertent exposure to visible and invisible LED radiation. Directly viewing the illumination module optical output through certain optical instruments (for example, eye loupes, magnifiers and microscopes) within a distance of 100 mm (3.94") may pose an eye hazard.

The Light Module is a non-serviceable part of the projector and must be replaced. Contact customer support to arrange a replacement.

## 5.5 Lens Replacement

**⚠ CAUTION** The projector is a class 2M source of visible and invisible LED radiation. Directly viewing the LED output with certain optical instruments (for example, eye loupes, magnifiers and microscopes) within a distance of 100 mm (3.94") may pose an eye hazard.

Lenses are easily replaced on the Mirage WU-L. See [2.2.2 Installing the Lens, on page 2-4](#).

# 6 Troubleshooting

If the projector is not operating properly, record the symptoms and use this section as a guide. If a solution to the problem cannot be found, contact your dealer for assistance. **NOTE:** *A Christie accredited service technician is required when opening an enclosure to diagnose any “probable cause”.*

## 6.1 Troubleshooting Guidelines

Read, understand and observe all warnings and precautions when diagnosing and servicing the projector.

- Ensure that the projector is plugged in.
- Ensure that cables are connected and not damaged.
- Power OFF the projector, wait 90 seconds to allow for cooling, and Power ON the projector. Check for a normal power up sequence.
- Check the projector status for error conditions and correct any issues if possible. See [6.2 System Warnings / Errors, on page 6-1](#).
- Check source reliability. Switch sources if possible.
- Use RS-232 serial communications to communicate with the projector during diagnosis.

## 6.2 System Warnings / Errors

When the projector finds a system malfunction, it displays a *System Warning* or a *System Error* message. Status and error information is available through:

- LEDs on the input panel of the projector. See [6.2.1 LED Status Display On the Projector, on page 6-2](#).
- Status page in the menu system: access **Main menu > Status**.
- Status page on the web UI: access **Main tab > Status** page and click on any category with a yellow or red indicator. For more information see [Appendix B: Web User Interface](#).
- On screen error messages: access **Main > Configuration > Menu Preferences > Display Error Messages (All)**. **NOTE:** *Display Error Messages must be set to “Screen” or “All” for System messages to appear on-screen.*

The status pages in the OSD menu system and the web UI update automatically when the error condition is corrected. The error code displayed on the status panel on the projector must be cleared manually by pressing EXIT twice from presentation level (no OSD on screen).

If an error code recurs, try resetting the projector by turning the projector OFF and ON.

A persistent error code may indicate that you need a Christie accredited service technician.

### System Warnings

Shows that a system malfunction exists. A system warning message replaces the input signal message and disappears when the input signal status changes. The projector will remain operational, but the message show a possibly serious problem that must be reported to the manufacturer. Reset the projector by powering it off and on again, cooling when necessary.







## System Errors

Shows that a serious malfunction exists and must be reported to the manufacturer as soon as possible. The projector will no longer operate. Reset the projector by powering it off and on again, cooling when necessary.

### 6.2.1 LED Status Display On the Projector

Projector status is indicated by a single three-color LED adjacent to a 2-digit status display. Refer to Table 6.1 for a description of LED variations that indicate operation status. A solid red LED indicates a system error and the corresponding error code indicates what the error is. Refer to Table 6.2 for a list of error codes. Press EXIT twice to acknowledge and clear the error code.

**Table 6.1 LED Operational Status Codes**

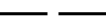
LED Status	2-Character Display	Description
 Solid yellow	Rotating	Warming up
	<b>PR</b> (Programming TI)	
	<b>FS</b> (Failsafe mode)	EM in fail safe mode, refer to the Visual Environments Projector Software Upgrade instruction sheet (020-100443-xx)
	 , static	STANDBY mode
	 , moving up and down	Brief cool down period
 Solid green	<ul style="list-style-type: none"> <li><b>BO</b> (Booting) when power first applied</li> <li><b>B1</b> (Boot phase 1) starting main script</li> <li><b>B2</b> (Boot phase 2) starting projector code</li> <li><b>B3</b> (Boot phase 3) about to initialize connections</li> </ul>	<ul style="list-style-type: none"> <li>When powering ON (booting) the projector, the LED will go through phases.</li> <li>Powered ON</li> <li>Normal operations</li> <li>EM ON</li> </ul>
	<ul style="list-style-type: none"> <li><b>SH</b> (Shutter Mode) active EM</li> </ul>	
 Flashing green		Keypad command sent - Command received
 Solid Red	System error – see <a href="#">Section 6.2.2 Error Codes</a>	
 Flashing red		<ul style="list-style-type: none"> <li>Key press error</li> <li>Wrong protocol sent</li> </ul>
blank		Waiting to establish a connection with PHM
blank	Rotating	Initializing hardware and connecting to PHM

### 6.2.2 Error Codes

If the status display window shows one of the codes in the Error Codes table you may need a Christie accredited service technician to repair the component identified by the error code.

Error codes are displayed in a three phase format:

- First 2 digits represent the component or error category
- Second 2 digits represent the specific problem
- Display off

This cycle repeats. The LED will be red while the error code is displayed.

Acknowledge and clear the error by pressing EXIT twice when at the presentation level (no OSD on the screen). If the error recurs then try resetting the projector by powering OFF and ON again. Contact the dealer if the problem persists or if you see a code not listed in *Table 6.2*.

**Table 6.2 Error Codes**

<b>Error Code</b>	<b>Item</b>	<b>Description</b>
<b>Light Engine</b>		
LE	00	Light engine Boot Failure
	01	Light engine link error
	02	Light engine initialization error
	03	Red LED Feedback Failure
	04	Green LED Feedback Failure
	05	Blue LED Feedback Failure
<b>Link</b>		
LI	01	Error on EM network
	02	Error on PHM network
	03	Error on ArrayLOC link
<b>Projector Head Module (PHM) Fan</b>		
FP	01	PHM FD Fan 1 stalled
	02	PHM FD Fan 2 stalled
	03	PHM LMC Fan 1 stalled
	04	PHM LMC Fan 2 stalled
<b>Electronic Module (EM) Fan</b>		
FE	01	EM Fan 1 stalled
	02	EM Fan 2 stalled

Table 6.2 Error Codes (Continued)

Projector Head Module (PHM) Sensors		
SP	01	PHM FD sensor 1 overtemp (not connected)
	02	PHM FD Air inlet overtemp or sensor not functioning
	03	PHM QDPC board overtemp or sensor not functioning
	04	PHM FD DMD overtemp or sensor not functioning
	05	PHM QDPC board overtemp or sensor not functioning
	06	LM Air inlet overtemp or sensor not functioning
	07	LM Air exhaust overtemp or sensor not functioning
	08	LM Power supply overtemp or sensor not functioning
	09	LM LED Driver overtemp or sensor not functioning
	10	LM ambient overtemp or sensor not functioning
	11	LM Red thermistor overtemp or sensor not functioning
	12	LM Green thermistor overtemp or sensor not functioning
	13	LM Blue thermistor overtemp or sensor not functioning
	14	LM IR thermistor overtemp or sensor not functioning
Electronics Module (EM) Sensors		
SE	01	EM Inlet
	02	Panel Driver Temperature
	03	Image Processor Temperature
	04	Option Card 1 Temperature
	05	Option Card 2 Temperature
	06	Option Card 3 Temperature
	07	Option Card 4 Temperature
Miscellaneous		
PR	01	EM/PHM Firmware mismatch; upgrade required

## 6.3 Power

### 6.3.1 Projector Does Not Power ON

1. Ensure that the projector is plugged in.
2. Ensure that cables are connected and not damaged.



## **6.4 Light Module**

### **6.4.1 Light Module Suddenly Goes OFF**

1. Check the shutter setting - if status display shows **SH** then the shutter may be active. Toggle through shutter modes. In **gray** shutter mode it should be possible to display menus.
2. Verify that the **RGB Brightness** is set sufficiently higher than zero to ensure a visible image. The DMDs may be overheated. Check for an alarm condition.

## **6.5 Displays**

### **6.5.1 The Projector is ON, but There is No Display**

1. Make sure the lens cover is removed from the lens.
2. Make sure the correct display button is selected in the channel setups.
3. Make sure AC power is connected.
4. Is an active source connected properly? Check the cable connections and make sure that the alternative source is selected.
5. Make sure that the DVI cable from the PHM to the EM is connected.
6. Are the test patterns accessible? If so, check source connections again.

### **6.5.2 The Display is Jittery or Unstable**

1. If the non-cinema display is jittery or blinking erratically, make sure that the source is properly connected and of adequate quality for detection. With a poor quality or improperly connected source, the projector repeatedly tries to display an image, however briefly.
2. The horizontal or vertical scan frequency of the input signal may be out of range for the projector.
3. The sync signal may be inadequate. Correct the source problem.

### **6.5.3 The Display is Faint**

1. The source may be double-terminated. Make sure that the source is terminated only once.
2. The source (if non-video) may need sync tip clamping.
3. Check **RGB Brightness** setting and **Brightness Uniformity** control.
4. If the Twist software was used, test by disabling the blend.

### **6.5.4 The Upper Portion of the Display is Waving, Tearing or Jittering**

1. This can occur with video or VCR sources. Check your source.
2. Check that the RGB Brightness setting is not unexpectedly low.

### 6.5.5 Portions of the Display are Cut OFF or Warped to the Opposite edge

Resizing may need adjustment. Adjust until the entire image is visible and centered.

### 6.5.6 Display Appears Compressed (Vertically Stretched)

1. The frequency of the pixel sampling clock is incorrect for the current source.
2. Sizing and positioning options may be adjusted poorly for the incoming source signal.
3. Check the geometry correction for warp or keystone correction.

### 6.5.7 Data is Cropped from Edges

1. To display the missing material, reduce image size to fill the display area available in the projector, then stretch vertically to fill the screen from top to bottom. Add the anamorphic lens to regain image width.
2. Check blend settings and masking.

### 6.5.8 Display Quality Appears to Drift from Good to Bad, Bad to Good

1. The source input signal may be of low quality.
2. The H or V frequency of the input may have changed at the source end.

### 6.5.9 Display has Suddenly Froze

If the screen blacks out inexplicably, it is possible that excessive voltage noise on the AC or ground input has interrupted the projector's ability to lock on to a signal. Power the projector down and up again.

### 6.5.10 Colors in the Display are Inaccurate

The color, tint, color space and/or color temperature settings may require adjustment at your input source, or on the web user interface **Channel > Page2** menu. Make Sure the correct PCF, TCGD and/or Color Space file for the source is used.

### 6.5.11 Display is Not Rectangular

1. Check leveling of the projector. Make sure the lens surface and screen are parallel to one another.
2. Is the vertical offset correct? Make the necessary adjustments to the vertical offset on the lens mount.
3. Check geometry corrections settings, for example keystone adjustment.

### 6.5.12 Display Is "Noisy"

1. Display adjustment at the input source may be required. Adjust pixel tracking, phase and filter. Noise is very common on YPbPr signals from a DVD player.
2. Make Sure the video input is terminated (75 ohms). If it is the last connection in a loop-through chain, the video input must be terminated at the last source input only.
3. The input signal and/or signal cables carrying the input signal may be of poor quality.

4. If the distance between the input source device and the projector is greater than 25 feet, signal amplification/conditioning may be required.
5. If the source is a VCR or off-air broadcast, detail may be set too high.

## **6.6 ArrayLOC**

### **6.6.1 Cannot Find Color Adjustment Controls**

Use the color adjustment options under the ArrayLOC menu: access **Main menu > Configuration > ArrayLOC**. Color Adjustments by X,Y and Color Saturation options are not available for general use. They are part of the passcode protected Service menu.

### **6.6.2 Color/Image Settings Are Greyed Out**

To enable ArrayLOC: access **Main menu > Configuration > ArrayLOC > Bright/ColorLOC Mode** and set to *Fixed, Cool, or Bright*.

**If ArrayLOC is enabled:**

- ArrayLOC handles brightness and color settings, and overrides other color settings, for example **Advanced Image Settings > Color Settings**.
- **Main menu > Configuration > ArrayLOC > Array Color Target** color settings are available for the master projector and are greyed out for all other projectors. To make your projector the master: access **Main menu > Configuration > ArrayLOC > Synchronize to This Projector**. Any projector in the array or BC group can be the master. The last projector to be set as the master is the master for the array (All) or BC group (Group). This setting is not saved between session.

### **6.6.3 Sensor Isn't Calibrated (yellow alert)**

Sensor calibration must be performed by Christie accredited service technicians. Contact Customer Support.

### **6.6.4 Invalid Target Gamut (yellow alert)**

A color setting is not valid for the current color space, for example a white point is outside of the gamut.

1. Access the Array Color Target menu: **Main > Configuration > ArrayLOC > Array Color Target**.
2. Check XY settings for the colors.

### **6.6.5 Unable to Achieve Target Brightness/Gamut (yellow alert)**

A projector in an array that cannot achieve minimum brightness or target color space will disable BCLOC and cease contributing data to performance calculations.

- Try lowering the target brightness or target color gamut settings until all the projectors can achieve the same performance.
- If the discrepancy is too big, the light module may need to be replaced. Call Customer Support.



### 6.6.6 TROUBLESHOOTING TREE - COLOR AND BRIGHTNESS ARRAY

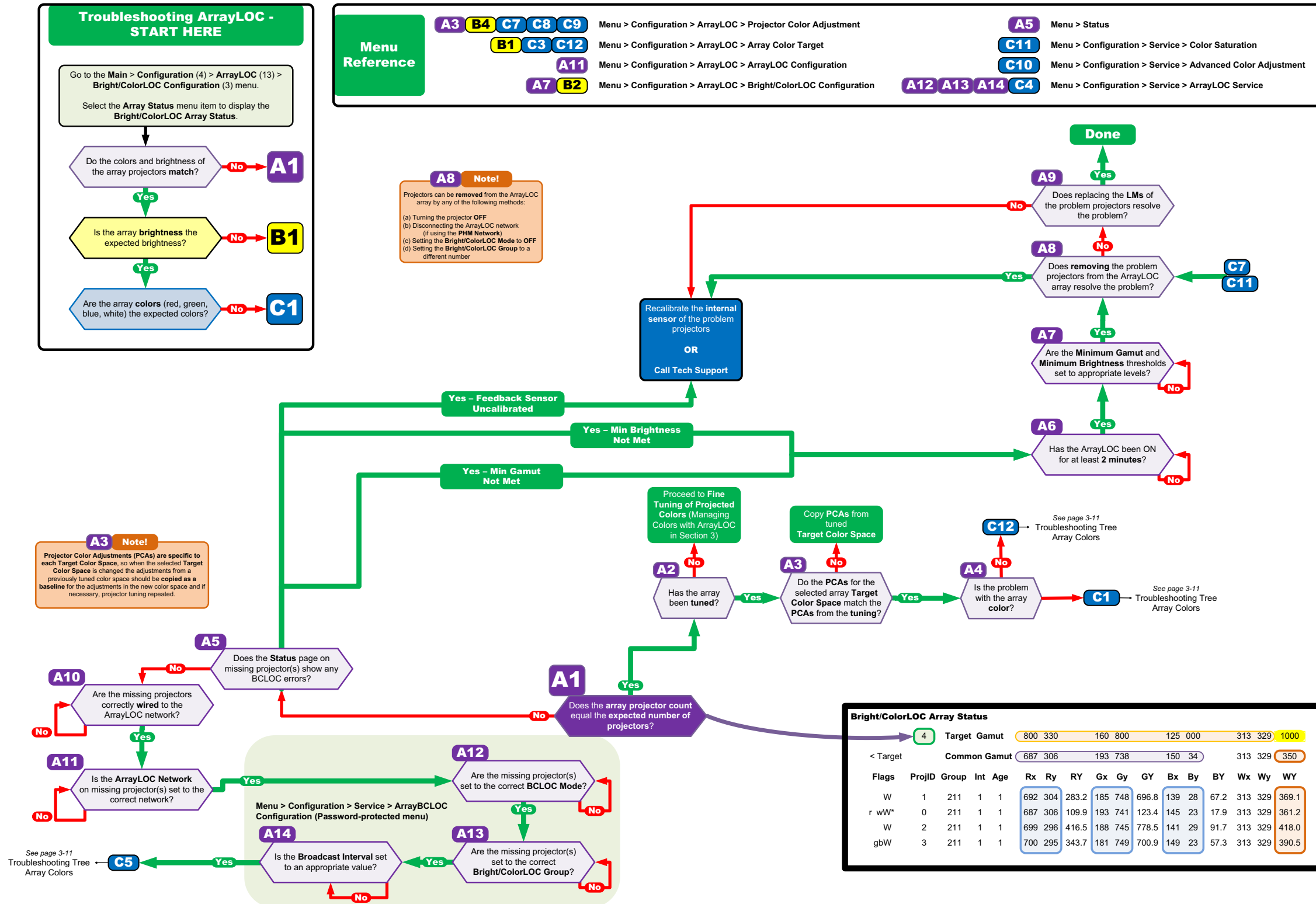

### 6.6.7 TROUBLESHOOTING TREE - ARRAY BRIGHTNESS

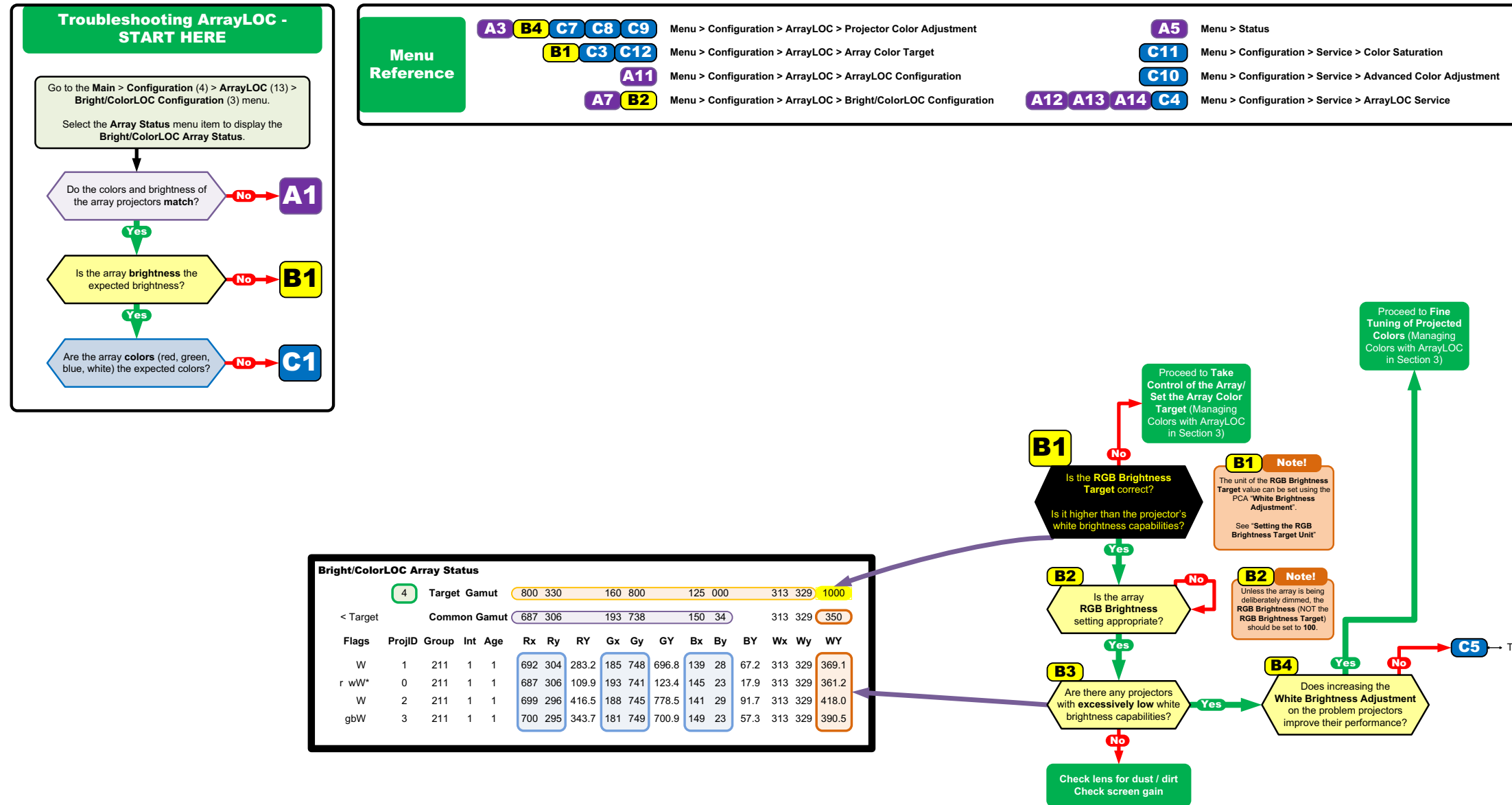

6.6.8 TROUBLESHOOTING TREE - ARRAY COLORS

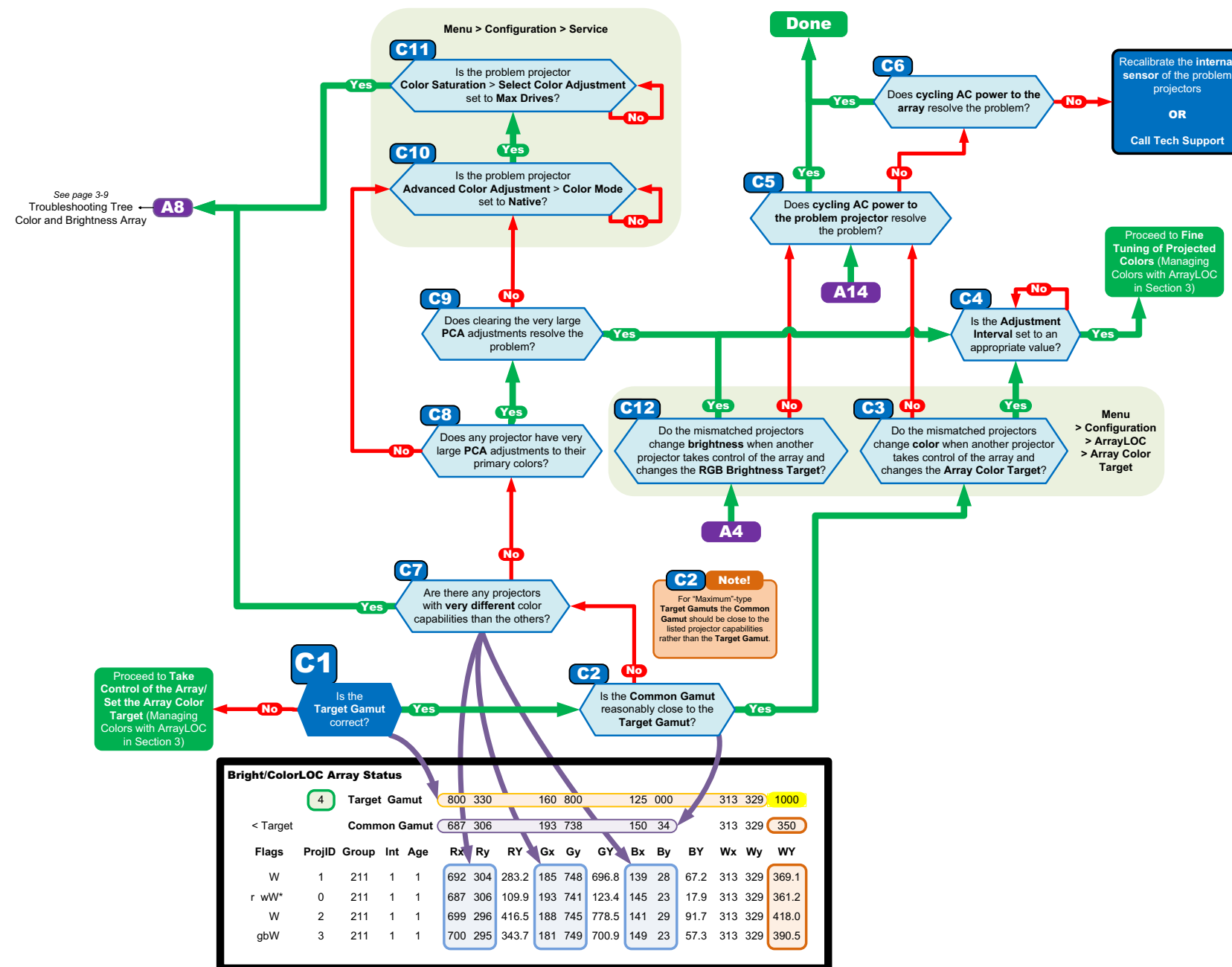
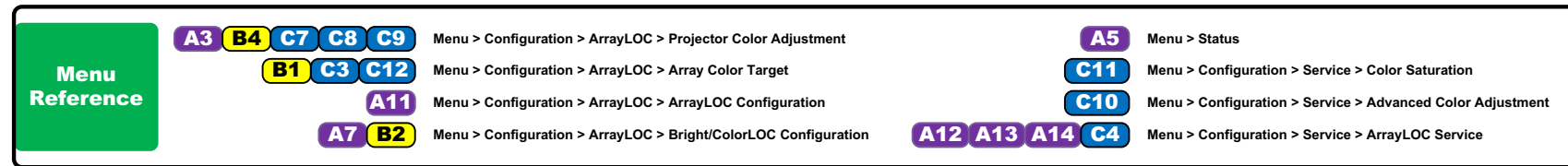
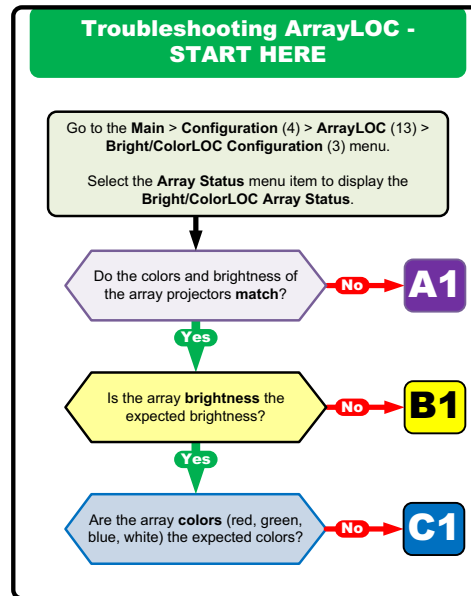

## 6.6.9 BRIGHT/COLORLOC SETUP WALKTHROUGH

Mirage WU-L ArrayLOC Bright/ColorLOC Setup – Do Nothing!

The default configuration of a Mirage WU-L projector has **ArrayLOC enabled** and configured to display a reasonably saturated gamut at the maximum brightness the array can support.

Unless one wishes to adjust the color of the primaries or whites, there is **no need to do anything else**. If one does wish to change the primary or white color, proceed to the **Change Projected Image Colors** guide.

If the projectors within the array do not seem to display matching white colors, white brightness or primary colors, then proceed to the **Tuning** guide.

ArrayLOC – Changing Projected Image Colors (Primary & White)

Step 1 – Take Control of the Array

**1a** Go to the **Main > Configuration (4) > ArrayLOC (13)** menu. This is the starting point for controlling **ArrayLOC**.

**Note!** Several controls in the **Bright/ColorLOC** and **Array Color Target** menus **cannot be changed** unless you take control of the array.

**1B** Select a projector you wish to use to control the array at this moment. Check the **"Synchronize to This Projector"** menu item on the selected projector. Now, all other projectors will copy changes you make in the **Array Color Target** or **ArrayLOC Configuration** submenus.

**1C** Select the **Array Color Target (4)** submenu and proceed to **step 2**.

**2a** Adjust the colors in the image by selecting the desired **Target Color Space**.

**2B** If a **User** color space is selected then the colors can be adjusted by entering the desired co-ordinates into the **"Target Red x", "Target Red y",** etc.

You can copy values from another color space to use as a starting point using the **"Copy Color Space From"** menu item.

**2C** Adjust the color of white in the image by selecting the desired **White Point**.

**2D** If a **User White** is selected as the white point then one of the following methods may be used to set the color of white.

The **"Target White x"** and **"Target White y"** can be set the desired white color co-ordinates.

OR

The white may be adjusted to a black-body color temperature by checking **"Set White to Color Temperature"** and adjusting **"White Color Temperature"**.

**2E** Adjust the brightness of the image by setting the **RGB Brightness Target**.

If you wish the image to be as bright as possible, set the **RGB Brightness Target** to a large number (such as 1000).

**Tip!** When a preset (non-User) color space is selected the white point is fixed at 6500 K (D65).

To create a color space with preset primaries but a different white point, select a **User** color space, then **"Copy Color Space From"** the desired preset color space. The **User** color space white point can then be adjusted as described in **step 2D**.

ArrayLOC – Bright/ColorLOC Tuning Guide

**Note!** Follow this procedure only if the brightness or color matching between projectors running ArrayLOC does not meet your satisfaction. Before continuing, check that the mismatched projectors are properly running ArrayLOC by verifying their **projector address** appears listed in the **Array Status** display.

Step 1 – Go to the ArrayLOC Menu

**1A** Go to the **Main > Configuration (4) > ArrayLOC (13)** menu. This is the starting point for controlling **ArrayLOC**.

**Tip!** **Projector Color Adjustments** are specific to each projector so changes can be made **without** taking control of the array by leaving box unchecked.

**1B** Select the **Projector Color Adjustment (5)** submenu and proceed to **step 2**.

Step 2 – Fine Tuning of Projected Colors

**Note!** **Projector Color Adjustments** are specific to each color space, so when the selected **Target Color Space** is changed the adjustments from a previously tuned color space should be copied (see Tip below) to the adjustments for the new color space and if necessary, projector tuning repeated.

**2A** Display a **white** test pattern on all projectors. On each projector, use the **ArrayLOC Projector Color Adjustments (PCA)** **"Red Part of White", "Green Part of White"** and **"Blue Part of White"** to adjust the white **color** to match the other projectors in the array (if necessary).

**2B** Display a **white** test pattern on all projectors. On each projector, use the **ArrayLOC Projector Color Adjustments (PCA)** **"White Brightness Adjustment" (WBA)** to adjust the white **brightness** to match the other projectors in the array (if necessary). Increasing the WBA will make the projector brighter, decreasing the WBA will dim the projector.

**Tip!** Once adjustments have been made to one target color space, they are usually a good starting point for other color spaces. Select the other color spaces and then use the **"Copy Adjustments From"** menu item to copy the adjustments from the color space that was tuned.

**2C** Display a red (or green or blue) test pattern on all projectors. On each projector, use the **ArrayLOC Projector Color Adjustments (PCA)** **"XXX Part of Red"** (or **"XXX Part of Green"**, or **"XXX Part of Blue"**), to adjust the color red (or green or blue) to match the other projectors in the array (if necessary).

If measuring the projected colors and comparing them to the **Common Gamut** numbers (shown in the **Array Status**), the guides at right indicate how to adjust the PCA to correct for differences. Look up the measured value compared to the **Common Gamut**.

For example, if the measured red was 660.325 and the common red was 640.330, then the measured X was high (660 > 640) but the measured Y was low (325 < 330).

Using the table for red (top table at right), look up **"Low X"** and **"High Y"** - it indicates that the **"Green Part of Red"** needs to be increased (or made positive).

**2D** Repeat this procedure for each projector that appears to not match the others in the array.



6.6.10 ARRAY STATUS DECODER & SETTING THE RGB BRIGHTNESS TARGET UNIT

### ArrayLOC – Array Status Decoder

**1** To display the **Array Status** page:  
Go to the **Main > Configuration (4) > ArrayLOC (13) > Bright/ColorLOC Configuration (3)** menu.  
Select the **Array Status** menu item.

**2** The **Target Gamut** is set in the **Array Color Target** menu.  
It consists of target primary coordinates, target white coordinates, and a target (white) RGB brightness.  
This gamut is "what you asked for".

**3** The **Common Brightness** has been calculated by ArrayLOC as the white brightness at the target white color that can be achieved by all projectors.

**4** The **Common Gamut** has been calculated by ArrayLOC as a gamut and brightness that can be achieved by all projectors.  
Where possible, this gamut is the same as the target gamut and brightness.  
This gamut is "what you get" - it is what the projector believes it is displaying.

**Flags help you identify which projectors are affecting the Common Gamut and Common Brightness**

< Target = alerts you that the Common Gamut is smaller than the Target Gamut

W = projector white brightness capability is less than Target Brightness

w = projector white brightness capability is determining Common Brightness

r, g, b = projector red, green or blue color is making the Common Gamut red, green or blue primary color less saturated than the target primary

\* = projector set to "Synchronize Group"

\*\* = projector set to "Synchronize All"

Bright/ColorLOC Array Status																
		Target Gamut			Common Gamut			Target White Point			RGB Brightness Target					
		800	330	160	800	125	000	313	329	1000						
		687	306	193	738	150	34	313	329	350						
Flags	ProjID	Group	Int	Age	Rx	Ry	RY	Gx	Gy	GY	Bx	By	BY	Wx	Wy	WY
W	1	211	1	1	692	304	283.2	185	748	696.8	139	28	67.2	313	329	369.1
r wW*	0	211	1	1	687	306	109.9	193	741	123.4	145	23	17.9	313	329	361.2
W	2	211	1	1	699	296	416.5	188	745	778.5	141	29	91.7	313	329	418.0
gbW	3	211	1	1	700	295	343.7	181	749	700.9	149	23	57.3	313	329	390.5

**Projector Address** helps you identify projectors.

Only projectors with the same Bright/ColorLOC Group as your projector will appear in Array Status (except for a projector set to "Synchronize All", who appears in everyone's Array Status).

Except where networked projectors must be broken into subgroups, this value should not be changed from its default value.

**Broadcast Interval** determines how quickly projectors update each other on their capability. This normally should not be changed from its default value.

**Projector Capabilities** are used by ArrayLOC to determine the Common Gamut and Common Brightness the array can achieve.

### ArrayLOC – Setting the RGB Brightness Target Unit

**Note!** This is an **advanced procedure** intended only for users who desire to control or monitor their array brightness in **specific units** (for example lumens, ft-L, etc.). Users who want the projectors to operate as bright as possible do not need to use this procedure.  
This procedure requires an external light meter.

#### Step 1 – Take Control of the Array

**1A** Go to the **Main > Configuration (4) > ArrayLOC (13)** menu.  
This is the starting point for controlling ArrayLOC.

**1B** Select a projector you wish to adjust first.  
Set this projector to "Synchronize to This Projector" by checking the box.

**1C** Select the **Array Color Target (4)** submenu and proceed to **step 2**.

#### Step 2 – Setting the RGB Brightness Target

**2A** Set the **RGB Brightness Target** to a value approximately half the brightness of the dimmest projector in the array.  
Set the value to approximately half the white brightness capability (WY) of the projector flagged "w" in the Array Status.  
Ensure the **Array Capability** shows "W100.0". This indicates that the array brightness is equal to the **RGB Brightness Target**.  
Note the **RGB Brightness Target** value – it will be used to calculate the expected brightness in step 3.

**2B** Select a desired unit for the **RGB Target Brightness**.  
The range of the **RGB Brightness Target** control is 1 to 2000.  
For example, if one wished to control the array brightness in ft-L and wanted to control the brightness in steps of 0.1 ft-L, then a unit of 0.1 ft-L would be appropriate.  
After completing step 3 with this unit, if an array brightness of 8.0 ft-L was desired then the **RGB Brightness Target** would be set to 80 = 8.0 / 0.1.

**2C** Move to the the **ArrayLOC Projector Color Adjustments (PCA)** menu.  
Display a **white test pattern** on the projector.

#### Step 3 – Changing RGB Target Brightness Unit

**3A** Calculate the **Expected Brightness** by converting the **RGB Brightness Target** value from step 2A into the desired unit using the selected **RGB Brightness Target Unit**.  
For example, if the **RGB Brightness Target** was set to 47 and the selected **RGB Brightness Target Unit** was 0.1 ft-L, then the expected brightness would be:  
**Expected Brightness = 47 \* 0.1 = 4.7 ft-L**

**3B** Measure the projected white brightness.  
Update the **White Brightness Adjustment (WBA)** as follows:  
**New WBA = Old WBA \* ( Expected Brightness / Measured Brightness )**  
Repeat step 3B until the measured brightness is sufficiently close to the expected brightness.



# 7 Specifications

## 7.1 Regulatory

### 7.1.1 Safety



Be aware of the caution label on the projector warning of possible eye hazard if the projected visible and invisible LED radiation light is viewed directly through certain optical instruments at close range. The image below indicates where the label is located.

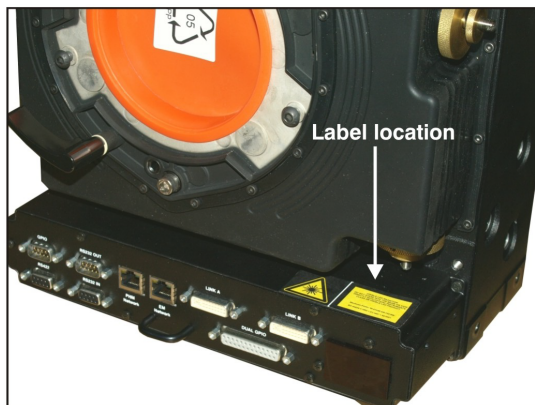

**⚠ CAUTION** The projector is a class 2M source of visible and invisible LED radiation. Directly viewing the LED output with certain optical instruments (for example, eye loupes, magnifiers and microscopes) within a distance of 100 mm (3.94") may pose an eye hazard.

- CSA C22.2 No. 60950-1-03 First Edition
- UL 60950-1 1<sup>st</sup> Edition
- IEC 60950-1:2001 European Norm, Safety of Information Technology Equipment

### 7.1.2 Environmental Regulations

- EU Directive (2002/95/EC) on the restriction of the uses of certain hazardous substances (RoHS) in electrical and electronic equipment and the applicable official amendment(s).
- EU Directive (2002/96/EC) on waste and electrical and electronic equipment (WEEE) and the applicable official amendment(s).
- Japanese Industrial Standard (JIS C 0950:2005) on marking for the presence of specific chemical substances for electrical and electronic equipment.
- China Ministry of Information Industry Order No.39 (02/2006) on the control of pollution caused by electronic information products, hazardous substances concentration limits (SJ/T11363-2006), and the applicable product marking requirement (SJ/T11364-2006).

### 7.1.3 Emissions

- FCC Code of Federal Regulations, Title 47, Part 15, Conducted and Radiated Emissions, Class A
- EN55022 (CISPR 22) for Information Technology Equipment, Conducted and Radiated, Class A
- EN61000-3-2 Induced Harmonic Distortion
- EN61000-3-3 Induced Voltage Fluctuations (Flicker)

### 7.1.4 Electromagnetic Compatibility

- FCC CFR47, Part 15, Subpart B, Class A – Unintentional Radiators
- CISPR 22: 2005 (Modified) / EN55022:2006, Class A – Information Technology Equipment
- CISPR 24: 1997 (Modified) +A1:2001+A2:2002 / EN55024: 1998 +A1:2001 +A2:2003 EMC
- Requirements - Information Technology Equipment

### 7.1.5 Immunity

- EN55024, specific to Information Technology Equipment (all parts), under which are:
  - EN61000-4-2 ESD
  - EN61000-4-3 Radiated Immunity
  - EN61000-4-4 Fast Transient/Burst Immunity
  - EN61000-4-5 Surge Immunity
  - EN61000-4-6 Immunity to Conducted Disturbances
  - EN61000-4-8 Magnetic Field Immunity
  - EN61000-4-11 Voltage Dips, Short Interruptions and Voltage Variations Immunity

## 7.2 Mirage WU-L Specifications

### 7.2.1 Display

- Resolution WUXGA (1920 x 1200)
- Brightness 440 lumens @ EBU  $\pm 10\%$
- Contrast ratio
  - Full-ON/Full-OFF 1500:1 min.
  - Native (ANSI) 450:1  $\pm 10\%$
- Brightness uniformity
  - 0 lens offset center-to-corner 90% min.
  - With software adjustment 100%
- Colors and gray scale
  - Resolution 8 bits
  - Displayable colors 16.8 million

- Color temperature
  - Factory default white color (K)                    6500 ± 500
  - Image white color (K)                                    3200 - 9300
  - Range of adjustment (K)                                3200 - 9600
  - Color Temp. variation (K)                                500

### 7.3 Lenses

LENS (0.637:1 EFFECTIVE WUXGA)	
Throw Ratio	
WU	0.637 nominal
Projection range (diagonal)	1016mm x 2550mm (40" x 100")
Lateral color error	0.5 pixels max.
Geometry distortion	0.1% max.

FIXED 0.75:1 HD/WUXGA	
Throw Ratio	
HD/WUXGA	0.75
Projection range (diagonal)	700mm x 2540mm (28" x 102")
Lateral color error	0.5 pixels max.
Geometry distortion	0.3% max.

ZOOM 1.2-1.6:1	
Throw Ratio	
HD/WUXGA	1.2-1.6
Projection range (diagonal)	1.5 m to 5.4 m (4.92 ft to 17.7 ft)
Lateral color error	<5 microns
Geometry distortion	<0.3% at 0 offset

### 7.3.1 Power Requirements

- Voltage range 90 - 240VAC nominal
- Line frequency 50 - 60Hz nominal
- Maximum inrush current 30A
- Power consumption 400W max.
- Typical current consumption 4A @ 100V  
(normal brightness, 1 input)
- Maximum current consumption 5.9A @ 100V  
(max. brightness, multiple inputs & external accessories)

**NOTES: 1)** Use of Manual RGB Adjustment to change projector brightness may increase power consumption beyond typical power consumption. **2)** Maximum power consumption includes provision for additional input cards and external accessories at maximum brightness.

### 7.3.2 Light Module

TYPE		3XPT120 LED MODULES
Operating Position	Any	
MTBF	60,000 hours	

### 7.3.3 Physical Specifications

#### Maximum Product Dimensions (L x W x H)

Projector Head Module Assembly (with LM)	219mm x 467mm x 286mm (8.6" x 18.4" x 11.3")
Electronic Module	426mm x 426mm x 169mm (16.8" x 16.8" x 6.7")

#### Product Weight

Projector Head Module Assembly and Light Module	15.9 kg (35 lb)
Electronic Module	4.4 kg (9.7 lb)

### 7.3.4 Projector Dimensions and Mounting Information

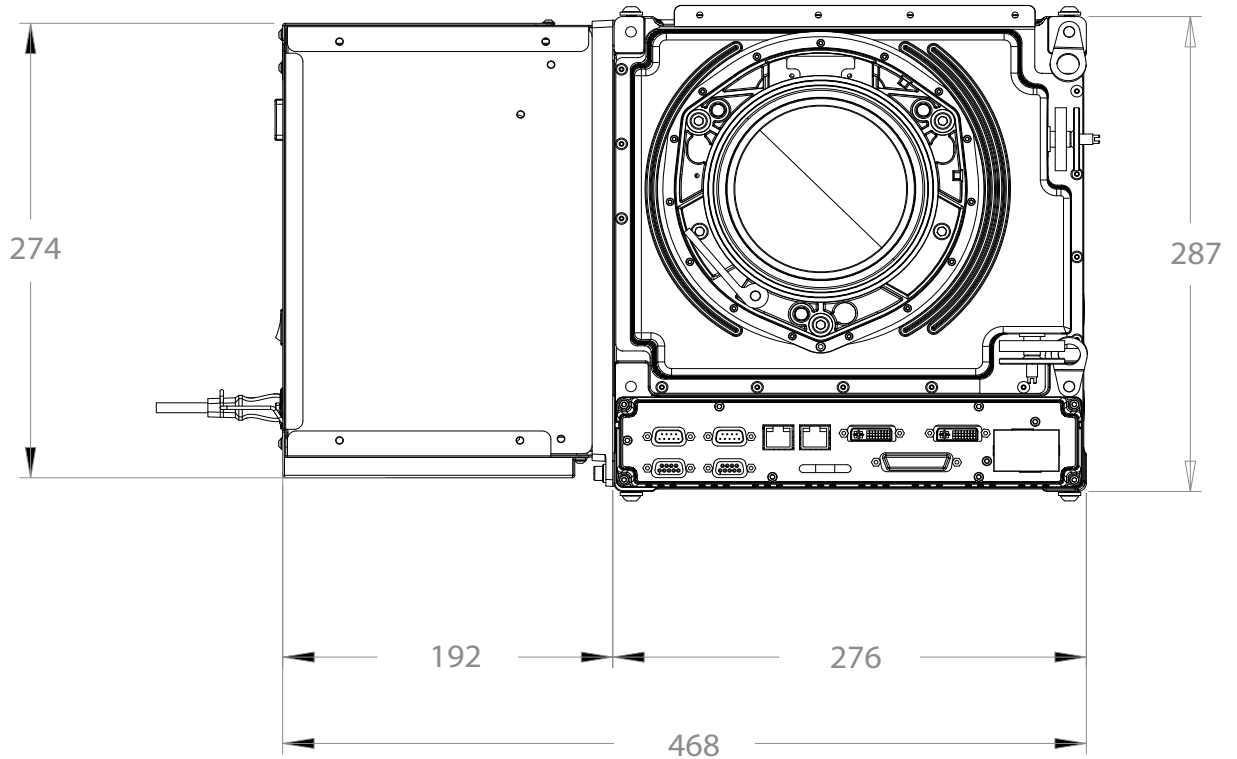

Figure 7-1 Mirage WU-L Front Dimensions

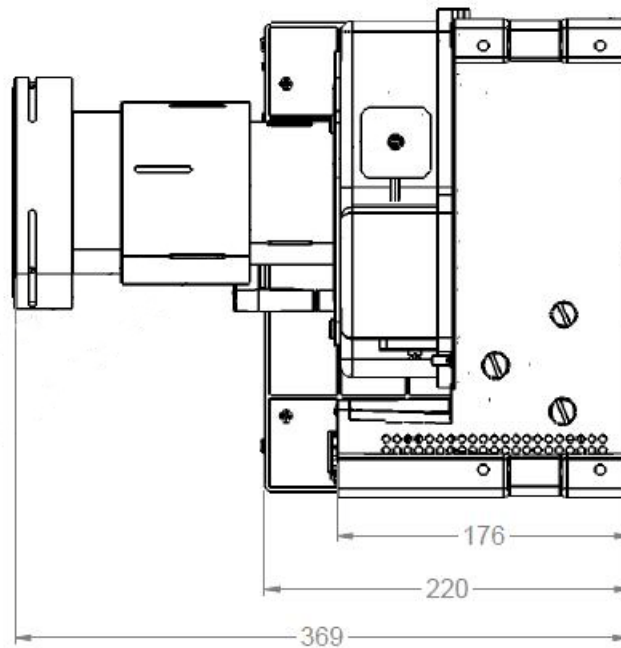

Figure 7-2 Mirage WU-L Side Dimensions with 1.2 - 1.6:1 Lens

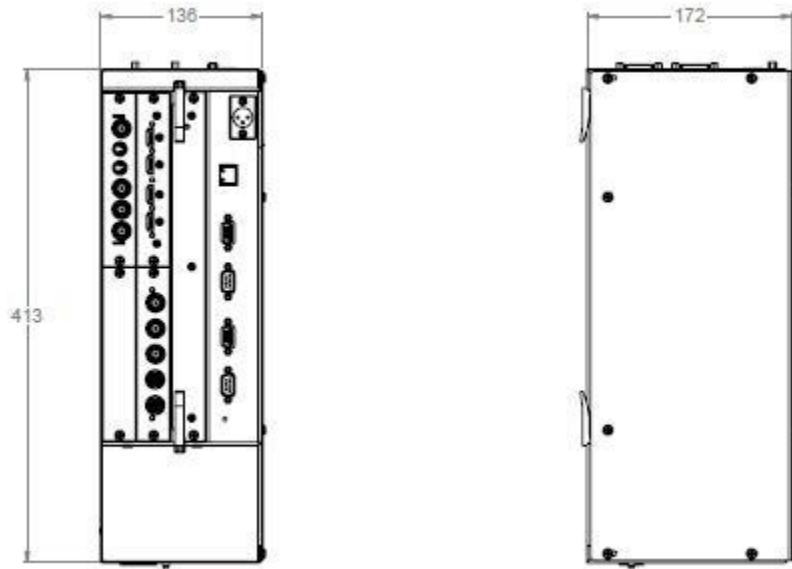

Figure 7-3 Electronic Module Dimensions

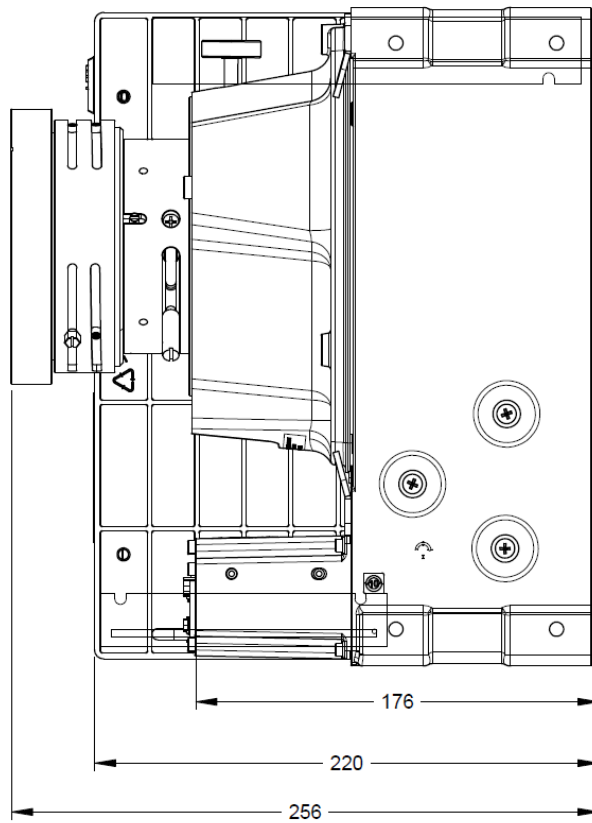

Figure 7-4 Mirage WU-L Side Dimensions with 0.64 Lens



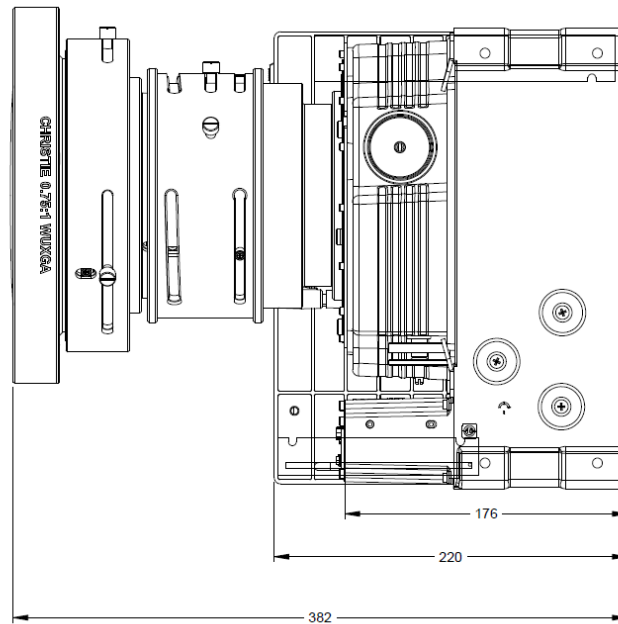

Figure 7-5 Mirage WU-L Side Dimensions with 0.75:1 Lens

**7.3.5 Environment**

**Operating Environment**

- Temperature 0°C to +40°C (40°F to 95°F)
- Humidity 15% - 90%
- Altitude 0-3048 m (10,000 ft)
- Vibration 0.5GRMS 10-500Hz, 15 minutes all axes

**Non-Operating Environment**

- Temperature -25°C to +70°C (-13°F to 158°F)  
with relative humidity varying between 0% - 95%
- Humidity 0% - 95% (non-condensing)
- Altitude 0-9144 m (30,000 ft)
- Vibration 0.74GRMS 10-300Hz, 15 minutes all axes

### 7.3.6 Standard and Optional Components

Due to continuing research, specifications are subject to change without notice. Specifications apply to all models unless otherwise noted.

#### Standard Components

- Line Cord (North American and European rated)
- Digital input card x2
- VGA input card

#### Optional Accessories

##### User Kit (P/N: 125-104106-xx)

- User Manual - electronic and hard copy (P/N: 020-100774-xx)
- Setup Guide - electronic and hard copy (P/N: 020-100782-xx)
- All necessary tools for normal servicing
- Twist CD
- Remote
- Cable

##### Input Cards

- Digital (DVI) Input Card, VGA Input Card (P/N: 108-312101-xx)
- Analog (RGB) Input Card (P/N: 108-309101-xx)
- Dual SDI/HDSI Card (P/N: 108-313101-xx)
- Twin HDMI Card (P/N:108-311101-xx)

##### Service Manual

- Service Manual (P/N:020-100777-xx)

##### Motoblend Mounting Kit

- Custom Motoblend Mounting Kit

##### Lenses

- Fixed 0.64:1 (HD/WUXGA) - P/N: 125-103105-xx
- Fixed 0.75:1 (HD/WUXGA) - P/N: 125-105107-xx
- Zoom 1.2-1.6:1 (HD/WUXGA) - P/N: 125-101103-xx

## 7.4 Inputs

### ANALOG RGB OR YPRPB

(Interlaced or Progressive Scan Format)

Pixel Clock Rate	13 – 270 MHz max	<b>NOTE:</b> Pixel rates above 150MHz require DIPC
Color Space	RGB or YPbPr	
Input Levels:	R, G, B, - with sync:	1.0Vp-p ±2dB
	R, G, B, - without sync:	0.7Vp-p ±2dB
	Pb, Pr	0.7p-p ±2dB
	DC Offset	±2V
Nominal Impedance	75 ohms	

### SYNC

(Interlaced or Progressive Scan Format)

Horizontal Frequency Range	15 – 150Hz
Vertical Frequency Range	23 – 150Hz
1,3	
Sync Type	Separate H and V
	Composite (bi-level, tri-level, XOR)
	Sync-On-Green/luma (bi-level, tri-level)
	Serrations and/or Equalization pulses
	MarcoVision compatible
Polarity 2	Positive or Negative
Input Levels 2	0.5Vpp – 4.0Vpp
DC Operating Range 2	±3V
Nominal Impedance 2	75 ohms
Horizontal Sync Duty Cycle	
3% min, 20% max	

**NOTES: 1)** Value specifies frame rate of non-interlaced sources and field rate for interlaced sources. Frame/field rates higher than the maximum refresh rate of the panels will be displayed at a lower rate. **2)** Does not apply to sync-on-green/luma. **3)** As the horizontal frequency increases and/or as the vertical scaling ratio of input lines to output lines increases many sources will run into the internal 180Mpix/s processing which limits the number of pixels that can be processed.

**DVI-I – ANALOG**

Input Characteristics	Same as Analog RGB, except as noted below.
Formats	RGB or YPbPr – video signal cannot be routed to the decoder
Sync Types	Separate H and V (direct or swapped) Bi-level – TTL levels only Composite (XOR, OR) Sync-on-green Serrations and/or Equalization pulses MacroVision (standard & progressive)
Analog Sync Logic Low	0V – 0.8v
Analog Sync Logic High	2.4V – 5V
Analog Sync Input Impedance	1kW

**DVI-I – DIGITAL**

Input Characteristics	meets DVI spec
DVI Cable Length	5m
Single Link DVI Pixel Rate	25-165 MPix/sec
Dual Link DVI pixel rate	165- 330 MPix/sec
EDID	Supported
HDCP (High Speed Digital Content Protection)	Unsupported

**RS-232/RS-422 SERIAL INPUT**

Connector Type	2 male DB9 (RS-232 OUT, GPIO) 2 female DB9 (RS-232 IN, RS-422 IN)
----------------	--

**NETWORK CONTROL**

Ethernet	1 RJ45 connector
Maximum Baud Rate	10/100 Mbps

**REMOTE CONTROL**

Type	Low Frequency IR with wired ability
Range	30 Meters
Laser Pointer	Included
Battery Type (2 Required)	AA, 1.5V Alkaline

**WIRED CONTROL**

Connector Type	XLR
Input Levels	High: 2.2V min. Low: 0.9V max. Power: 500mA @ 5V

# **A Interconnect Drawing**



A.1 INTERCONNECT DRAWING

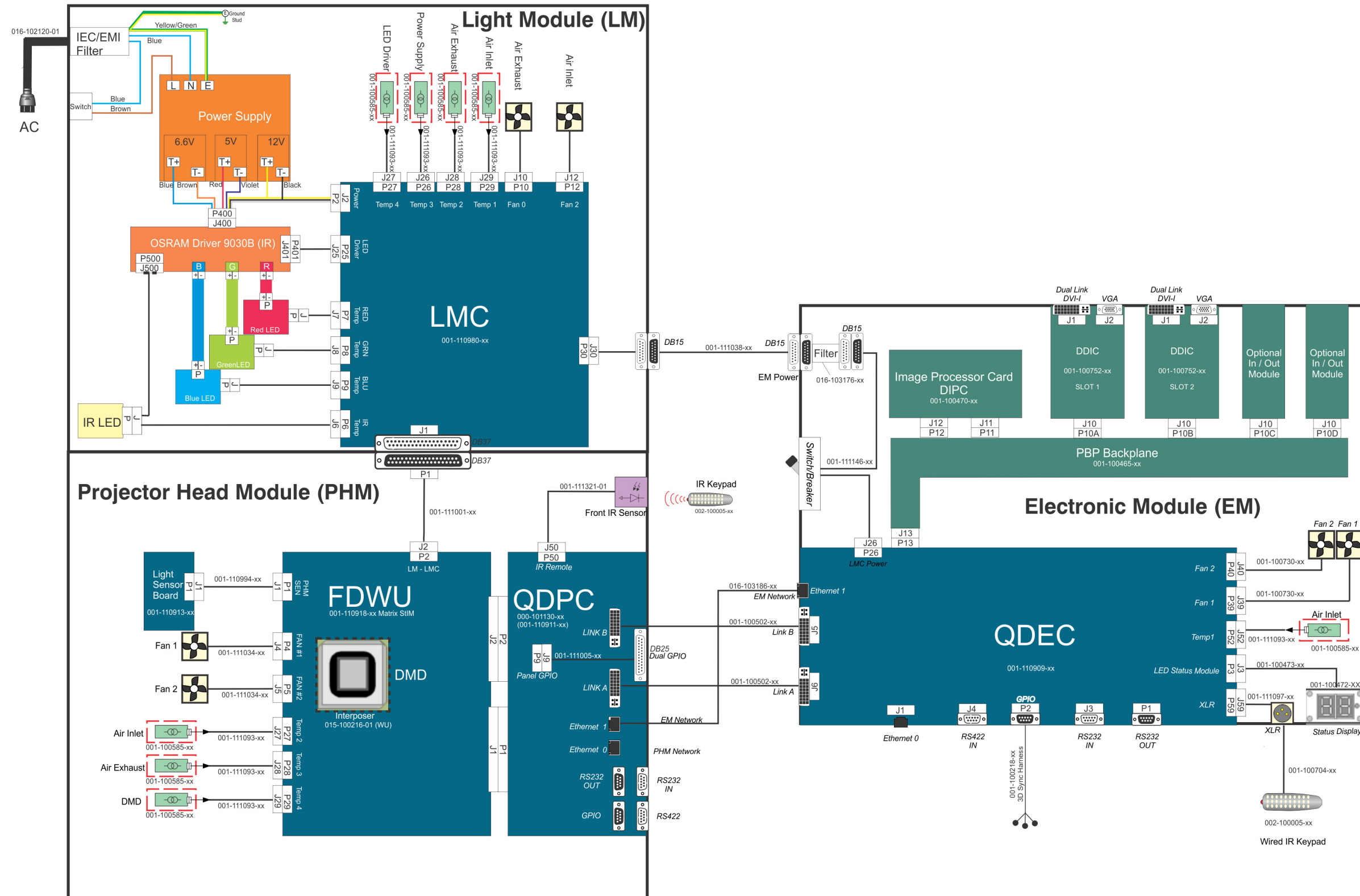

# Appendix B: Web User Interface

## B.1 Logging On

**IMPORTANT:** Before logging on to the system, ensure that you select the appropriate language required. Your language selection only affects the web user interface. The language used by the projector's on-screen display (OSD) is not affected. See Figure B-1.

1. Open your web browser and type the IP address (in the address bar) assigned to your projector.
2. Select the appropriate language from the **Language** drop-down list, located in the upper left-hand corner. See [Figure B-1](#).
3. Type your user name and password in the **User Name** and **Password** (see [Figure B-2](#)) fields respectively. Both entries are case-sensitive.



Figure B-1 Language drop-down list

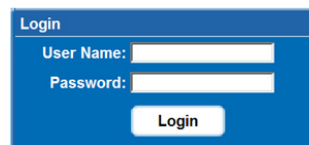

Figure B-2 Login

4. Click the **Login** button. The **Main** window (see [Figure B-3](#)) appears.

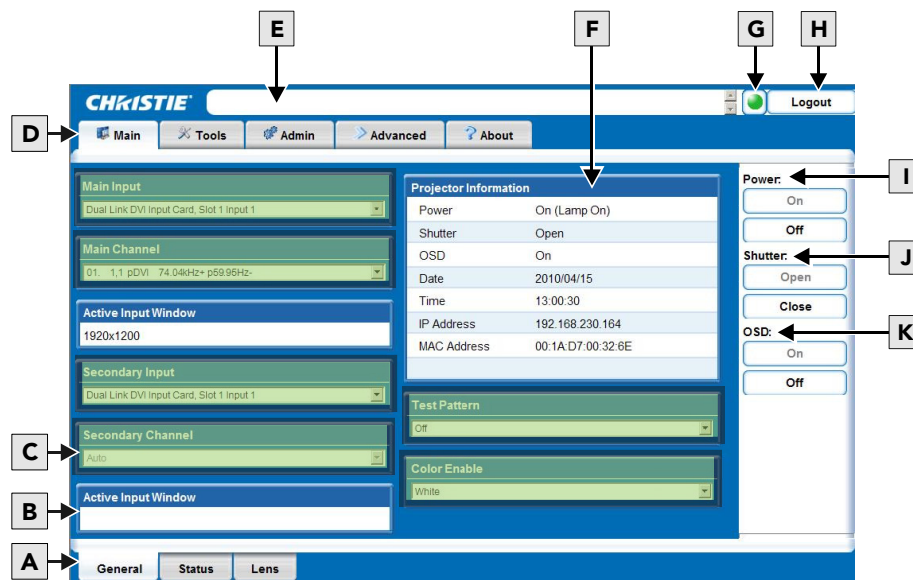

Figure B-3 Main window



The following table describes each area found in the Main window. See *Figure B-3*.

A	<b>Secondary Tabs</b> (specific to a primary tab) located along the bottom of the Main window.	B	<b>Secondary Input Active Input Window</b> and <b>Main Active Input Window</b> sections are read-only.	C	These sections provide drop-down list selections (refer to <b>Section 3, Operation</b> for more details).
D	<b>Primary Tabs</b> located along the top of the Main window.	E	<b>Current Status Bar</b> provides information messages according to the current status of the projector.	F	<b>Projector Information</b> section is read-only.
G	<b>Status Indicator</b> displays the overall status of the projector, based on the 12 categories of information available. <b>NOTE:</b> Click the <b>Status Indicator</b> LED to display the <b>Status</b> window and obtain more information about any current errors and warnings. See Section B.3.2 Main Tab - Status.	H	<b>Logout</b> button (located at the top right corner of the web browser) is used to logout you off of the web user interface and the projector.	I	<b>Power</b> section contains an <b>On</b> and <b>Off</b> button. Only one is enabled depending on the current powered state of the projector.
J	<b>Shutter</b> section contains an <b>Open</b> and <b>Close</b> button. Only one is enabled depending on the current state of the projector's shutter.	K	<b>OSD</b> (On Screen Display) section contains an <b>On</b> and <b>Off</b> button. Only one is enabled depending on the current state of the projector's on-screen display.		

## B.2 Navigating the Web User Interface

**NOTICE:** *Internet Explorer V6.0 has known performance issues and is not recommended to be used as the primary web browser for the web user interface. It is recommended that you use Internet Explorer V7.0.*

It is not recommended that you use the web browser's navigation functionality (i.e. the **Back** and **Forward** functions) as this will cause you to lose your web connection. It is recommended that you navigate using the application interface and related functionality detailed in this section.

### B.2.1 Help Text

You can move your mouse pointer over most buttons or fields to display related help information. See *Figure B-4*. To disable this feature, click **Admin > System > Tooltip: Hide**. **NOTE:** *Help text is not available for a disabled buttons.*

When working with the projector menu system on the Tools tab, highlight the menu option and press "h".

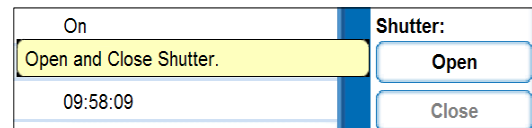

Figure B-4 Help Mouse Over Example

### B.3 Basic Operation

This section discusses the primary tabs located along the top of the application window. Each primary tab also has related secondary tabs which are located along the bottom of each tab as follows:

<b>Main</b> <ul style="list-style-type: none"> <li>• General</li> <li>• Status</li> </ul>	<b>Tools</b> <ul style="list-style-type: none"> <li>• Virtual OSD</li> </ul>	<b>Admin</b> <ul style="list-style-type: none"> <li>• System</li> <li>• Users</li> </ul>	<b>About</b> <ul style="list-style-type: none"> <li>• Version</li> <li>• License</li> </ul>
---	--	--	---

#### B.3.1 Main Tab - General

Under the **Main** tab, select the **General** secondary tab to view general information about Inputs, Channels, Projector Information, Test *Pattern*, and Color Enable (see *Figure B-3*). For detailed information refer to *Section 3 Operation*.

#### B.3.2 Main Tab - Status

Under the **Main** tab, select the **Status** secondary tab to view the 12 Category LED status lights which indicate the projector’s highest critical state. See *Figure B-5*. The LED color of the category indicates that it is in one of the following states:

- Green = Good
- Yellow = Warning
- Red = Error

For more information about each LED, click an LED button for details.

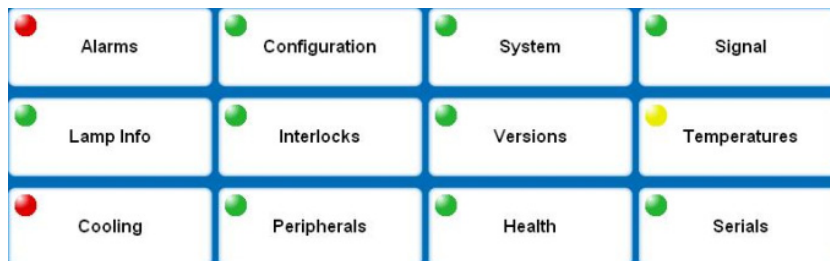

Figure B-5 Category Status Example

### B.3.3 Tools Tab - Virtual OSD

The **Tools** tab defaults to the **Virtual OSD** secondary tab. See *Figure B-6*.

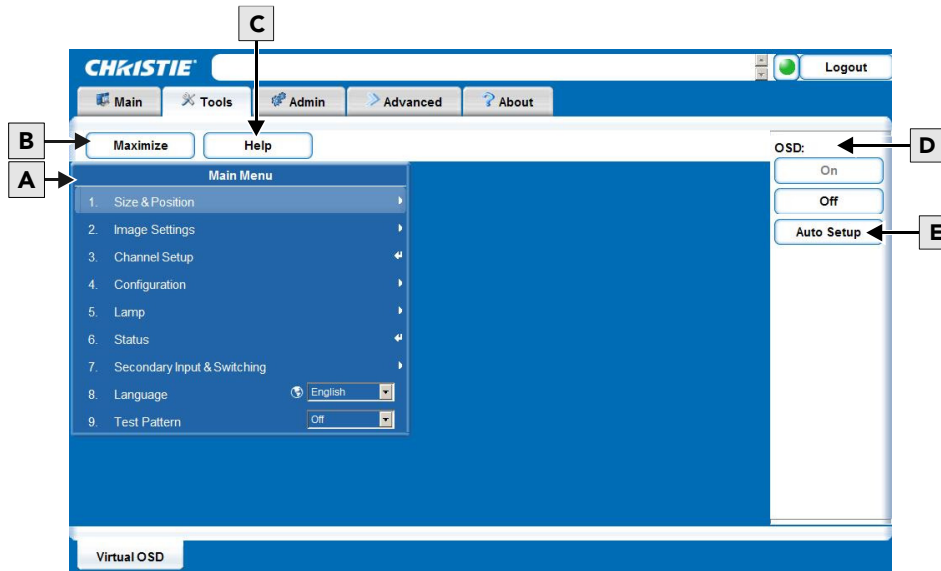

Figure B-6 Tools Window

The following table describes each area found in the **Tools** window. See *Figure B-6*.

A	<p><b>Virtual OSD</b> tab presents the <b>Main Menu</b> (refer to <b>Appendix A, Menu Tree</b> for more details).</p>	<p>B The <b>Maximize/Minimize</b> button toggles depending on the current state of the projector. When maximized, the Virtual OSD displays over the entire page so that subsequent menus can be viewed without scrolling. No access to tabs when maximized.</p>	<p>C <b>Help</b> button presents a pop-up window which provides information to help you navigate within the current menu.</p>
D	<p><b>OSD</b> section contains an <b>On</b> and <b>Off</b> button. Only one is enabled depending on the current state of the OSD. Control of the OSD is always available through the remote.</p>	<p>E <b>Auto Setup</b> button uses the manufacture’s default settings (refer to Section 3, Operation for more details).</p>	

### Virtual OSD Menu

Selecting an option from a menu displays its associated window, showing related information and input fields. To return to the previous menu, click the menu’s title bar (see *Figure B-7*).

To return to a previous menu, click on the current menu’s title bar or press **ESC**. **NOTE:** *Click the **Maximize** button to view the full screen size.*

Various types of menu elements (*Figure B-8* and *Figure B-9*) allow you to define projector settings.

These include:

- Field entries
- Drop-down lists
- Check boxes
- Sliders

**NOTE:** *When a menu option is modified through the Virtual OSD menu, the projector setting takes effect immediately.*

### Entering a number in a numeric field

1. Position your mouse pointer within the numeric field that you wish to edit.
2. Click to highlight the field entry. **NOTE:** *If you click the menu option, the field cannot be edited.*
3. Edit the field entry.
4. Press **Enter** to save your changes.

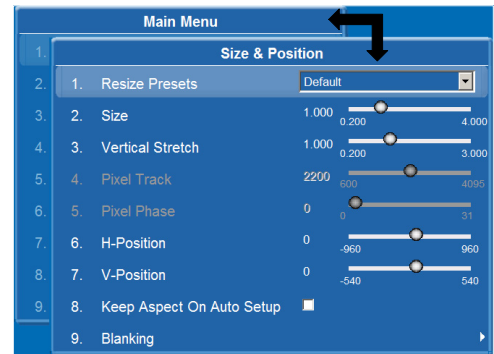

Figure B-7 View Previous Menu

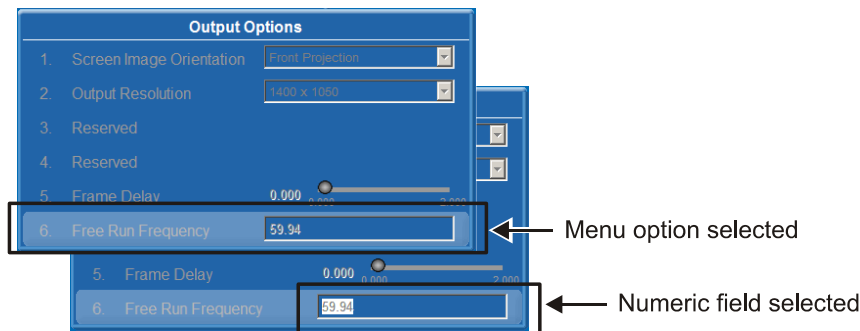

Figure B-8 Select Numeric Field

### Selecting an option from a drop-down list

1. Click the option drop-down arrow to open the drop-down list.
2. Locate and select the desired option.

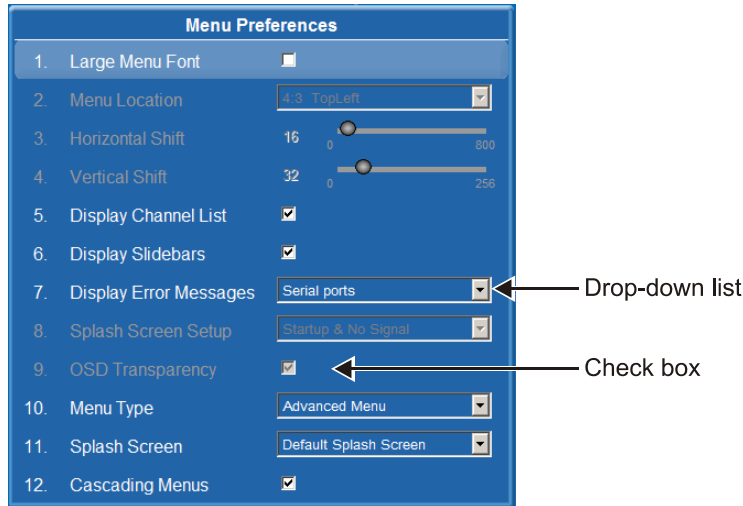

Figure B-9 Types of Menu Elements

### Selecting or clearing a check box

To select or clear a check box, click the check box with your mouse pointer. This enables or clears the option respectively.

### Clock setting

1. Click within the field (i.e. **Lamp Regeneration Start Time** option) to allow access.
2. Change the **Hour**, **Minute**, and **Seconds** fields (double-digit field entry) as required.

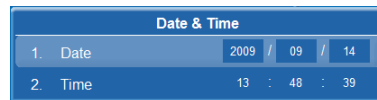

Figure B-10 Dates

### B.3.4 Admin Tab - System

Under the **Admin** tab, select the **System** secondary tab to upgrade, upload, backup and restore specific files, change the Logo position, background color, gamma properties, and interrogate the projector (creating a zip file of information).

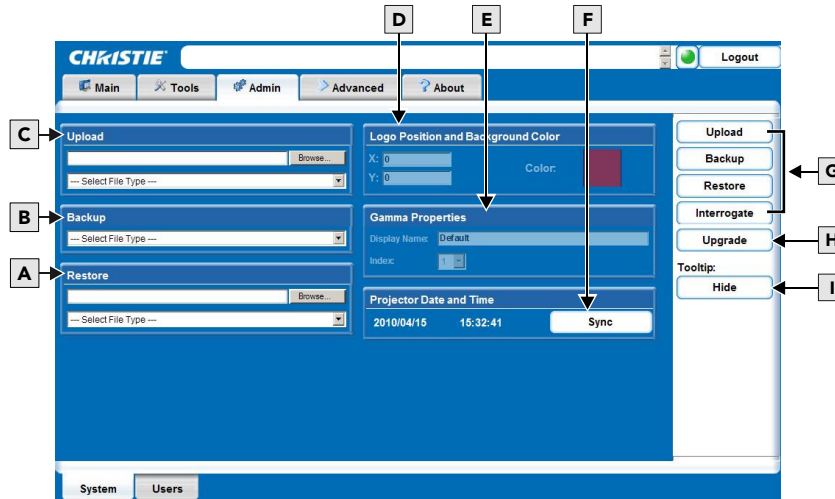

Figure B-11 Admin window

The following table describes each area found in the **Admin** window. See [Figure B-11](#).

<p><b>A</b> <b>Restore</b> section allows you to select the file and file type that you wish to restore.</p>	<p><b>B</b> <b>Backup</b> section allows you to select the file and file type that you wish to backup.</p>	<p><b>C</b> <b>Upload</b> section allows you to select the file and file type that you wish to upload.</p>
<p><b>D</b> <b>Logo Position and Background Color</b> section is enabled when you select a <b>Logo</b> file type from the <b>Upload</b> section.</p>	<p><b>E</b> <b>Gamma Properties</b> section is enabled when you select a <b>Gamma</b> file type from the <b>Upload</b> section.</p>	<p><b>F</b> <b>Sync</b> button is used to set the projector date and time to match that on your computer.</p>
<p><b>G</b> <b>Upload, Backup, Restore, and Interrogator</b> buttons perform their respective functions, after the setting for the function have first been selected from the drop-down lists, and other fields on the left.</p>	<p><b>H</b> <b>Upgrade</b> button, refer to the <i>Visual Environments Projector Software Upgrade</i> instruction sheet, P/N 020-100443-xx. This button is disabled if the projector is not in Standby mode.</p>	<p><b>I</b> <b>Hide</b> button allows you to disable the display of the help text.</p>

## Uploading a Logo File or Gamma File

**NOTICE:** The projector must be powered on to enable the Upload drop-down list.

1. Select the file type (**Logo** or **Gamma**) from the **Upload** drop-down list.

**NOTE:** If you select a Logo file type, it **MUST** be a 24-bit, bitmap file. This enables the Logo Position and Background Color section. Proceed to Step 3a.

If you select a Gamma file type, it **MUST** be a .csv file with 1024 values (all colors same) or 1024 x 3 for individual colors. This enables the Gamma Properties section. Proceed to Step 4a.

- a. Enter the Logo position for the **X** and **Y** fields.
- b. Click the **Color** square to open the **Choose Background Color** window, choose the desired background color from the color palette, and click **OK**. The color square changes to the selected color.
- c. Click the **Upload** button to display the **Logo Upload** window. Click **Yes** or **No** to confirm or cancel the upload.

An **Upload in Progress** window appears.

2. Click the Upload **Browse** button to open the **Choose file** window.
3. Locate and select the file you wish to upload from a Network drive location or from your hard drive.
4. Click the **Upload** button to display the **Logo Upload** window.
  - a. Enter a descriptive name in the **Display Name** field.
  - b. Click the **Upload** button to display the **Gamma Upload** window. Click **Yes** or **No** to confirm or cancel the upload respectively.

An **Upload in Progress** window appears.

## Creating a Backup File

1. Select a file type (**All**, **Preferences**, **Configuration**, **Channels**, or **Users**) from the **Backup** drop-down list.
2. Click **Backup** to initiate the download. A **Backup in Progress** bar appears. Once finished, a **File Download** window appears.
3. Click **Save** to open a **Save As** window.
4. Locate and select a folder within your Network drive or hard-drive where you wish to save the file.
5. Click **Save**.

## Restoring a File

1. Select a file type (**All**, **Preferences**, **Configuration**, **Channels**, **Users** or **Real Time Events**) from the **Restore** drop-down list. **NOTE:** Do not select *All* unless transferring all files from one projector to another or cloning.
2. Click the **Browse** button to locate and select the file you wish to restore from a Network drive location or from your hard drive.
3. Click **Restore** to initiate the restore. A **Restore in Progress** bar appears. Once finished, a confirmation message appears.

### Performing a Diagnostic Test using Interrogator

1. Click **Interrogate** to initiate the diagnostic test and download the diagnostic test results to your computer. A **Interrogator in Progress** bar appears. Once the download is complete, a **File Download** window appears. **NOTE:** *Once the Interrogate function begins, you must allow it to run until completion.*
2. Click **Save** to save the diagnostic test results file to your Network drive or hard-drive.

### B.3.5 Admin Tab - Users

Under the **Admin** tab, select the **Users** secondary tab. Options are provided to add to and delete users from accessing the projector, and change passwords. **NOTES: 1)** *Do not use capitalization for usernames or passwords. If capitalization is used for the username or password, it will automatically convert it to lower case.* **2)** *Usernames can be a minimum of 4 and maximum of 32 characters. Passwords can be a minimum of 4 and maximum of 128 characters.*

#### Creating a User Name and Password

1. Click **Add User** to open the **Add User** window.
2. Type your username and password in the **User name** and **Password** fields respectively.
3. Re-type your password in the **Re-type Password** field.
4. Click **Ok** to save.

#### Change Password

1. Select the user whose password you wish to change from the **Users** window.
2. Click **Change Password** to open the **Password Change** window.
3. Type the new password in the **Password** field.
4. Re-type the password in the **Re-type Password** field.
5. Click **Ok** to save or **Cancel** to ignore.

#### Delete User

1. Select the user that you wish to remove from the **Users** window.
2. Click **Delete User** to open the **Delete User** window. A confirmation message appears.
3. Click **Yes** or **No** to proceed or ignore the action.



### B.3.6 Advanced Tabbed Page - RTE

The RTE (Real-Time Events) tab is where you can manage real-time events (i.e. add, delete, edit, copy and setup the GPIO) as described in the following section.

#### RTE Buttons

The real-time event buttons include the following:

- **Add**, create a new event
- **Delete**, remove one or multiple existing events
- **Delete All**, remove all events
- **Edit**, change or add information for an existing event
- **Copy**, clone an existing event
- **Stop**, discontinue the event running
- **GPIO Setup**, used to configure the GPIO pins as inputs/outputs and to set the current state of the output pins

#### To Add a Scheduled Event

Scheduled events include a command or sequence of commands, for example, (PWR1) or (PWR1) (SHU1).

1. Click **Add** to open the **RTE Wizard**.
2. Select the **Scheduled Event** tab. **NOTE:** *The scheduled tab is always selected by default on add.*

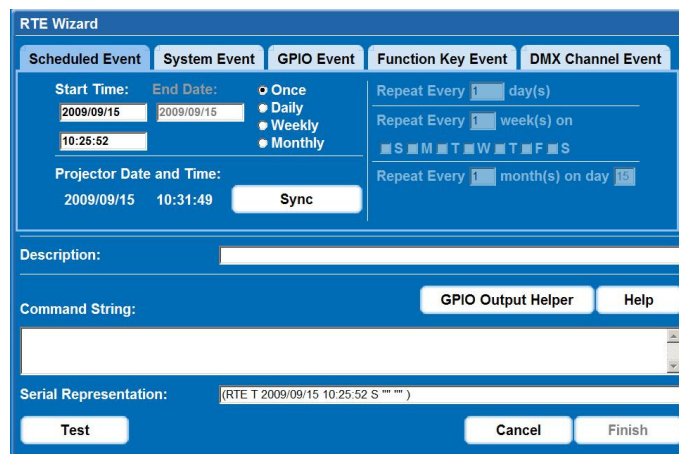

The screenshot shows the 'RTE Wizard' window with the 'Scheduled Event' tab selected. The 'Start Time' is set to 2009/09/15 10:25:52. The 'End Date' is 2009/09/15. The frequency options are 'Once', 'Daily', 'Weekly', and 'Monthly'. The 'Repeat Every' field is set to 1 day(s). The 'Repeat Every' field is set to 1 week(s) on S M T W T F S. The 'Repeat Every' field is set to 1 month(s) on day 15. The 'Projector Date and Time' is 2009/09/15 10:31:49. The 'Sync' button is visible. The 'Description' field is empty. The 'Command String' field is empty. The 'Serial Representation' field shows '(RTE T 2009/09/15 10:25:52 S "" "" )'. The 'Test', 'Cancel', and 'Finish' buttons are at the bottom.

Figure B-12 Scheduled Event Window

3. Select the frequency option for the event by selecting either **Once**, **Daily**, **Weekly**, or **Monthly**. **NOTE:** *End Date is enabled when Daily, Weekly or Monthly repeat options are selected.* **NOTE:** *Depending on the frequency option that you select, a related Repeat Every is highlighted on the tab. Use this area to enter the frequency of each event.*
4. Click within the **Start Time** field to open a calendar pop-up window.
5. Navigate to and choose a desired date. The selected date will populate the **Start Time** field.
6. In the field below the **Start Time** field, enter a start time in the format “hr:min:sec”. The default is the current time.
7. Click **Sync** to set the computer and projector time to be the same; otherwise, the event will run based on the projector time.

8. Enter a description of the scheduled event in the **Description** field. **NOTE:** *Maximum of 100 characters.*
9. Enter a serial command or a sequence of serial commands, with which you wish the projector to perform in the **Command String** box.
  - If a **GPIO** command string is needed, click the **GPIO Output Helper** button for instructions on how to create the command structure. **NOTES:** **1)** The **Output** field contains 7 blocks which refer to the 7 I/O pins on the GPIO connector. Pin 1 = +12V and Pin 5 = Ground. These are not included. **2)** Clicking a block toggles between H, L, and X. See *Figure B-13*. See *Appendix D: Serial Command Reference* for detailed information.

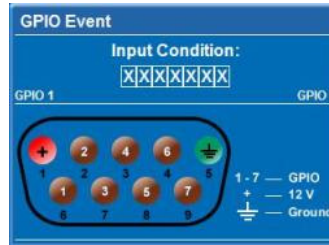

Figure B-13 GPIO Output Helper

- **NOTE:** *The contents of the **Serial Representation** box are read only.*
- Click the **Help** button for a description of special RTE commands available for adding loops and delays to the command sequence.
- Click the **Test** button to test the entered command string. **NOTE:** *If the test passed or failed, a green or red icon appears to the right side of the **Test** button as shown in *Figure B-14*.*



Figure B-14 Test Buttons

10. Click **Finish** to create the added event. **NOTES** **1)** *The added event appears in the **RTE Listing** window. See *Figure B-15*. **2)** *To activate or deactivate one or more RTEs listed in the **RTE Listing** window, select or clear each check box in the **Active** column accordingly.**

RTE Listing			
Active	Description	Trigger	Status
<input type="checkbox"/>	RTE #1 Daily - (Scheduled Event)	2009/09/04 01:01:01	Idle
<input type="checkbox"/>	RTE #2 Weekly - (Scheduled Event)	2009/09/04 02:02:02	Idle
<input type="checkbox"/>	RTE #3 Monthly - (Scheduled Event)	2009/09/04 04:04:04	Idle
<input type="checkbox"/>	RTE #4 No Signal - (System Event)	No Signal	Idle
<input type="checkbox"/>	RTE #5 LXLHLXL - (GPIO Event)	LXLHLXL	Idle

Figure B-15 RTE Listing Window Example

## To Add a System Event

1. Click **Add** to open the **RTE Wizard**.
2. Select the System Event tab.
3. Select a type of event from the **System Event** drop-down list. See [Figure B-16](#).

Figure B-16 Add System Event

**NOTE:** Depending on the selection made, additional selections are made available in the second drop-down list located underneath (i.e. *Input Change > Input 1, Slot 1*).

## To Add a GPIO Event

1. Click **Add** to open the **RTE Wizard**.
2. Select the GPIO Event tab.
3. For the **GPIO Event** option define the **Input Condition** field as required. The **Input Condition** field contains 7 blocks which refer to the 7 I/O pins on the GPIO connector. Pin 1 = +12V and Pin 5 = Ground are not included or changed. **2**) Clicking a block toggles between H, L, and X as shown in [Figure B-17](#). See [Appendix D: Serial Command Reference](#) for detailed information.

Figure B-17 GPIO Event

## To Add a Function Key Event

1. Click **Add** to open the **RTE Wizard**.
2. Select the **Function Key Event** tab.
3. Select a **Func** (function) key from the drop-down list as shown in [Figure B-18](#). Refer to [Section 3 Operation](#) for detailed information.

Figure B-18 Function Key Event

**To Add a DMX Channel Event**

1. Click **Add** to open the **RTE Wizard**.
2. Select the DMX Channel Event tab.
3. Select a **DMX** channel (DMX-56 to DMX-61) from the drop-down list as shown in Figure. Refer to [Section 3 Operation](#) for detailed information.

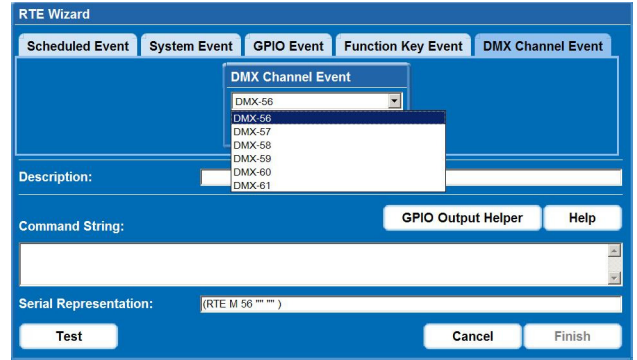

Figure B-19 DMX Channel Event

**B.3.7 To Add a Serial Command**

1. Enter a serial command in the **Serial Command** field. **NOTE:** For serial commands, see [Appendix D: Serial Command Reference](#).
2. Click **Send** to add the serial command. See [Figure B-20 Add Serial Command](#).

**B.3.8 About Tabbed Page**

Provides information about the projector’s software version, model, serial number, and license information.

**NOTE:** The information provided on the *Version* and *License* tabs are read-only.

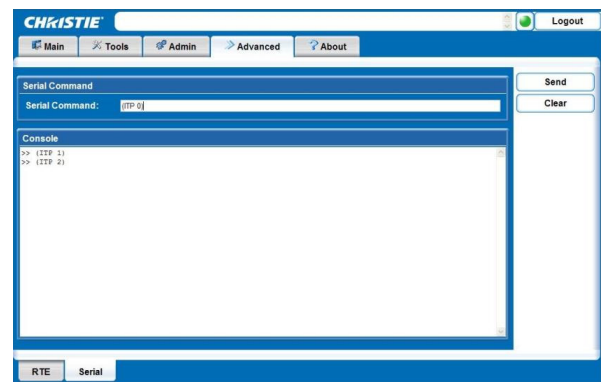

Figure B-20 Add Serial Command



# Appendix C: Serial Communication

## C.1 Introduction

This document describes the serial communication protocol, consisting of ASCII text messages, used to control a Mirage WU-L projector remotely.

### C.1.1 Connection and Use

Once you have connected your computer to either the RS-232 IN or RS-422 IN port (depending on which standard is supported by your computer) or to the ETHERNET port on a projector, you can remotely access projector controls and image setups, issue commands or queries, and receive replies. Use these bi-directional messages to:

- Control multiple projectors
- Obtain a projector's status report
- Diagnose performance problems

**NOTES:** **1)** *Section 7 Specifications for all cable requirements and other connection details.* **2)** *Some commands are operational only when projector is powered up.*

## C.2 Understanding Message Format

Messages can be one of three types:

- **Set** - A command to set a projector parameter at a specific level, such as changing to a certain channel.
- **Request** - A request for information, such as what channel is currently in use.
- **Reply** - The projector returns the data in response to a request or as confirmation of a command.

All "Remote Control" information passes IN and OUT of the projector as a simple text message, consisting of a three letter command code, an optional 4-letter subcode, and any related data. When a parameter for a specific source is being accessed, the 4-letter subcode will be added on to the Command code. A number of optional features (message acknowledgements, checksums, and network addressing) can be included.

Generally, most commands include 0 or 1 data fields or parameters. Where applicable, a message may expand to include additional parameters of related details.

The smallest step size for any parameter is always 1. For some controls (i.e. Size) the value displayed on the screen has a decimal point. (e.g. 0.200 to 4.000) In this case, the values used for the serial communications is an integer value (e.g. 200 to 4000), not the decimal value seen on the screen.

Regardless of message type or origin, all messages use the same basic format and code. Opening and closing round brackets (parentheses) surround each message, see [Table C.1](#).

Table C.1 Message Formats

SOURCE	MESSAGE FORMAT	FUNCTION	EXAMPLES
From Controller	(Code Data)	SET (set contrast of main image to 500)	(CON500) or (CON 500)
	(Code+Subcode Data)	SET (set contrast of PIP image to 500)	(CON+PIIP500) or (CON +PIIP 500)
From Controller	(Code ?)	REQUEST (what is current contrast?)	(CON?) or (CON ?)
	(Code+Subcode ?)	REQUEST (what is contrast of PIP image?)	(CON+PIIP?) or (CON+PIIP ?)
From Projector	(Code Data)	REPLY (contrast is 500)	(CON!500)
	(Code+Subcode Data)	REPLY (PIP contrast is 500)	(CON+PIIP!500)

## C.2.1 Basic Message Structure

The following component fields comprise a standard ASCII message. Optional fields, such as extra characters for special modes, restrictions or added functionality, are shown in italics, with the exception of Notes.

### Start and End of Message

Every message begins with the “(” (left bracket) character and ends with the “)” (right bracket) character.

**NOTE:** *If the start character (left bracket) is received before an end character of the previous message, the partial (previous) message is discarded.*

### Prefix Characters (Optional)

For acknowledgement that the projector has responded, and/or to maximize message integrity, insert 1 or 2 special characters before the 3-character function code:

Special Character	Description
\$	Simple Acknowledgment, which will cause a ‘\$’ character to be sent back from the projector when it has finished processing the message. See <a href="#">C.2.4 Maximizing Message Integrity</a> .
#	Full Acknowledgment, which will cause an echo of the message as a reply to be sent back from the projector when it has finished processing the message. See <a href="#">C.2.4 Maximizing Message Integrity</a> .
&	Checksum, which will allow a checksum to be put as the last parameter in the message for verification at the projector. See <a href="#">C.2.4 Maximizing Message Integrity</a> .

### Projector Numbers (Optional)

To control a selected projector or controller within a group, include its assigned number or address just before the 3-character ASCII Function code. See [C.2.7 Network Operation](#).

### Function Code

The projector function you wish to work with, such as channel selection or gamma, is represented by a 3-character ASCII code (A-Z, upper or lowercase). This Function code appears immediately after the leading ( (left bracket) that starts the message. In messages sent to the projector that do not have a Subcode, a space between the Function code, and the first parameter (or special character) is optional.

**+Subcode**

The projector function you wish to work with may have one or more subcodes that will allow you to select a specific source, image, channel or subfunction. The Subcode is represented by a 4-character ASCII code (A-Z, upper or lowercase, and 0-9). This Subcode appears immediately after the Function code, with a “+” character to separate the code, and subcode. If there is no Subcode, the “+” (plus sign) is also omitted. In messages sent to the projector that do have a subcode, a space between the subcode and the first parameter (or special character) is optional.

**Request/Reply Symbols**

If the controller is requesting information from the projector, a “?” (question mark) appears directly after the *Function* code. If the projector is replying, an “!” (exclamation mark) appears directly after the *Function* code. For **Set** type messages sent to the projector, neither of these characters appear. Data directly follows the code and subcode.

**Other Special Functions (Optional)**

To add functionality to the current message, include one or more of the following special characters between the Function code/Subcode, and the first parameter. If more than one, add them in any order. See [C.2.6 Flow Control](#).

<b>C</b>	Control Class Inquiry
<b>D</b>	Default value/Text
<b>E</b>	Enable Control Inquiry
<b>G</b>	Access Group Inquiry
<b>H</b>	Return the Help text for a control
<b>L</b>	Return a list of options for ‘list’ controls
<b>M</b>	Find min/max adjustments (i.e., range)
<b>N</b>	Return the name of the control
<b>T</b>	Return the type of control (i.e. Slidebar etc.)

**Data**

The value for a given projector state, such as “ON” or “OFF”, appears in ASCII-decimal format directly after the request/reply symbol. You can add an optional space after the symbol (i.e., before the data) in a set message, but data in replies follow the “!” (exclamation) symbol without a space. Other details to remember about data:

- All values returned by the projector (reply messages) have a fixed length, regardless of the actual value. For a specific parameter, the length will always be the same (e.g. contrast is always returned as 3 characters, projector number is always returned as 5 characters). The minimum parameter size is 3 characters. Values that are less than the pre-defined size will be padded with leading zeros as needed. Parameters which have negative signs (-) are zero padded after the negative sign, and will have one less digit to make space for the sign.



- If entering a negative number, there must be a space between the code/subcode, and the value. For example, (CRM3) and (CRM 3) can both be used when the number is positive. (CRM -2) is acceptable, but (CRM-2) is not.
- Data in set messages to the projector do not require padding with zeros.
- Within each message, multiple parameters of data must be separated by one “space” character.
- Text parameters such as channel names are enclosed in double quotes following the data, as in “Name”.

### Text Parameters

Most data is simply a numerical value, however some messages also require text. For example, a channel naming message typically includes a text-based name. Enclose this text in double quotation marks, as in “*Tilt the Wagon*”. Use all characters as desired except for the following special characters shown in the left column below. These special characters require a 2-character combination. See [C.2.2 Sample Messages and their Meaning](#).

**Table C.2 Special Characters for Text**

If you want this...	Enter this...	Description
\	\\	Backslash
”	\"	Quote
(	\(	Left Bracket
)	\)	Right Bracket
0x0A	\n	New line - if the text can be displayed on more than one line, this will set the line break.
	\h##	Sends one arbitrary code defined by the 2 hexadecimal digits ##

## C.2.2 Sample Messages and their Meaning

**Table C.3 Sample Messages and Their Meaning**

For a Single Projector		
Message Format	Function	Example
(Code Data)	SET (set contrast of main image to 500)	(CON500)
(Code+Subcode Data)	SET (set contrast of PIP image to 500)	(CON+PIIP500)
(Code?)	REQUEST (what is current contrast?)	(CON?)
(Code+Subcode?)	REQUEST (what is contrast of PIP image?)	(CON+PIIP?)
(Code!Data)	REPLY (contrast is 64)	(CON!64)
(Code+Subcode!Data)	REPLY (PIP contrast is 64)	(CON+PIIP!64)
(\$Code Data)	SET AND ACKNOWLEDGE MESSAGE (message processed?)	(\$CON64)
(&Code+Subcode Data Checksum)	SET WITH CHECKSUM	(&CON64 240)

For a Specific Projector within a Network with 1 Controller present		
Message Format	Function	Example
(Dest Addr Code Data)	SET (turn projector #5 on)	(5pwr1)
(\$Dest Addr Code Data)	SET AND ACKNOWLEDGE MESSAGE (message processed?ffr55)	(\$5pwr1)

For a Specific Projector within a Network with Multiple Controllers present		
Message Format	Function	Example
(Dest Addr Src Code?)	REQUEST (get contrast from projector #5 to controller #2)	(5 2con?)

For a Specific Projector within a Network with Multiple Controllers present		
Message Format	Function	Example
(\$Dest Addr Src Code Data)	SET AND ACKNOWLEDGE MESSAGE (is message from controller #2 processed by projector #5)	(\$5 2con?)
(Dest Addr Src Code!Data)	REPLY (from projector #5 to controller #2: contrast is 64)	(002 005con!064)

### C.2.3 What is Actually Sent in a Message

Although you will send and read messages as strings of ASCII characters, the actual message travels as a sequence of bytes. Each character in this sequence requires 1 byte. The example below illustrates a “lamp limit is 2000 hours” reply from the projector.

ASCII =	(	L	P	L	!	2	0	0	0	)
HEX =	0x28	0x4	0x50	0x28	0x21	0x32	0x30	0x30	0x30	0x29

### C.2.4 Maximizing Message Integrity

For additional reassurance and/or maximum message integrity, you can insert 1 or 2 special characters:

- **Acknowledgments:** If you want assurance from the projector (or group of projectors) that a set message has been processed, request an acknowledgement. An acknowledgement is returned after a message has been received and fully executed by the projector (i.e. in the case of a source switch it is not sent until the switch is complete). If a message is not able to execute for some reason (i.e. invalid parameters, timeout, etc) a NAK is returned instead (Not-Acknowledge). Note that requesting an acknowledgement serves no purpose when included in a request message, since the acknowledgement will be redundant to the actual reply from the projector. However, if requested, the “\$” acknowledgement from the projector will follow the reply.

There are two types of acknowledgements:

- **Simple Acknowledgements:** Insert a “\$” character just after the start code “(“. This will only return a ‘\$’. This will only return a '\$' on success, or a '^' on failure (NAK).
- **Full Acknowledgements:** Insert a “#” character just after the start code “(“. This will return the message sent, as a reply.

This is a quick way to confirm success with set messages, and is particularly useful with long-distance communication links or where the projectors and/or images are not visible from the controller.

Acknowledgements can also be a type of flow control.

- **Checksums:** For maximum message integrity, add a checksum character “&” just after the start code “(“. You must then also include the correct checksum total (0-255) just before the “)” end code. Make sure to add a space before the calculated checksum to separate it from the last data parameter:

The checksum is the low order byte of the sum of the ASCII values of all characters between the “(“and the beginning of the checksum, but not including either. It does include the space in front of the checksum. Calculate the checksum for the above “set contrast to 64” command as follows:

```
CHECKSUM EXAMPLE = & + c + o + n + 6 + 4 + 'space'
= 26h+63h +6Fh +6E h +36h +$34h +$20h
= 01F0h
= F0h when only the low byte is used
= 240
```

The projector collects all of the message bytes as defined in the first byte of the message, then creates its own checksum value for comparison with the checksum included in the controller’s message. If the values match, the message is considered to have been correctly received—otherwise the message is discarded.

**NOTES: 1)** ‘h’ indicates a hex number. **2)** If a “request” message has a checksum so will the reply. **3)** If using both “acknowledge” and “checksum”, either character can occur first.

### C.2.5 Accessing Specific Channels or Inputs

For several commands (for example, ASR, Auto Channel Select) you can direct the message to particular channel, input or image. To do this, include a subcode after the function code.

**Example:**

```
(ASR 1)Enable Auto Channel Select for the channel being used by the Main image
(ASR+MAIN 1)Enable Auto Channel Select for the channel being used by the Main image
(ASR+PIIP 1)Enable Auto Channel Select for the channel being used by the PIP image
(ASR+C003 1)Enable Auto Channel Select for channel 3
(BBL+IN12 30)Set the bottom blanking value on slot 1 input 2 to value 30
```

It is only possible to set parameters from a specific channel or input if that parameter is stored separately for each channel or input. This function cannot be used for parameters that are specified for the projector as a whole such as projector address. The serial commands listed in the document specify which subcodes are applicable to each function.

### C.2.6 Flow Control

Normally messages can be sent to the projector before processing of earlier messages is complete—the projector will just store messages in a buffer until ready to process. However, if a series of messages is sent it is possible that the projector may not be able to process them as fast as they arrive and the buffer will become full. If this happens, the projector will send the 13h (Xoff) code to instruct the controller (or any devices preparing to transmit) to cease transmission. At this point, the controller must respond immediately and send no more than 10 extra characters or they may be lost (i.e., the projector is able to accommodate the receipt of up to 10 more bytes after it sends 13h (Xoff)). When the buffer is once again available, the projector will send a 11h (Xon) command to resume transmission.

**NOTE:** *Xon and Xoff controls apply to both directions of communication. The projector will not send more than 3 characters after it has received a 13h (Xoff) code.*

### C.2.7 Network Operation

Up to 1000 projectors can be linked together in a chain with the ‘OUT’ port on one connected to the ‘IN’ port on the next. A controller connected to the ‘IN’ port on the first projector can control them all, either by broadcasting messages which have no address and are thus seen by all projectors, or by directing messages to specific projector addresses.

To work with a specific projector in a group, the projectors must first be assigned a unique I.D.—either a projector number or an Ethernet IP address. Insert the number of the target projector between the starting ‘(’ and the 3-character ASCII code.

**Table C.4 - Message for Specific Projector**

( Addr Code Data )

Each projector compares the message address with its own address and, if matching, responds and processes the message. If the address does not match, the message is passed on until it reaches the intended projector.

Although messages without an address are always broadcast, you can also broadcast by including the reply destination address 65535. This ensures that replies go to a specific controller address rather than being broadcast. The projector will also include its address.

**Table C.5 - Message for Projector from a Specific Controller**

( Dest Src Code Data )

If you have more than one controller on a network, ensure to include both a source address and a destination address. With a single controller on the network, its address is never required. Place the source address between the destination address and 3-character code, including a space before and after as shown. **NOTE:** *Replies from a projector do not contain an address unless the request message includes both a destination address and a source address—i.e., a reply to a request having only a destination address will not have any source address.*

**Table C.6 - Message for Specific Projector from a Specific Controller**

( Dest Src Code Data )

Examples		
Command	Message from Controller	Reply from Projector
Turn Projector #5 on.	(5pwr1)	{none}
What is the contrast level in Projector 30?	(30con?)	(CON!127)
Return Contrast from Projector #30 to Controller #2.	(30 2con?)	(00002 00030con!127)

## C.3 Description Of Control Types

### C.3.1 Subclasses

- **Power Down Controls** - These controls are accessible when the projector is in Standby power mode (i.e. power off) as well as when powered on.
- **Power Up Controls** - These controls are only accessible when the system electronics are fully powered (not necessarily lamp on).

### C.3.2 Control Groups

- **Unsaved Controls** - These controls are not saved to flash. The settings are not maintained between power sessions.
- **Saved Controls** - These controls are saved to flash. The settings are persistent between power sessions.
- **Preference Controls** - These controls are transferable from one projector to another. Example: NET+SUB0 (projector subnet).
- **Configuration Controls** - These controls are projector specific settings. They are non-transferable between projectors. Example: NET+ETH0 (projector IP address).
- **Channel Controls** - These settings are specific to a particular input signal. Example: BRT (signal brightness).
- **Option Card Controls** - These settings are specific to a particular option card type / slot combination.

### C.3.3 Access Levels

- **Operator** - Command is available at the operator level log in.
- **Advanced** - Command is available at the advanced operator level log in.
- **Admin** - Command is available at the administrator level log in.
- **Service** - Command is available at the service level log in.

# Appendix D: Serial Command Reference

The following tables define the serial commands associated with the Mirage WU-L projector.

<b>(ABL) ARRAY BRIGHT COLOR LOC</b>	
CONTROL GROUP: Preference    SUBCLASS: Power Up    ACCESS LEVEL: Operator	
<p><b>DESCRIPTION</b></p> <p>This command is used to set parameters that control how the Array Bright/ColorLOC feature operates. From this control you enable the mode in which you want to operate the feature: target brightness, target gamut, update intervals, and other miscellaneous parameters. This command is persistent, and will save the “synchronize to this projector” operation between power-ups.</p>	
<b>SUBCODE</b>	<b>DESCRIPTION OF USE</b>
EABL	<p>Enable Array Bright/ColorLOC:</p> <p>0 = OFF</p> <p>1 = fixed mode (uses CCA only)</p> <p>2 = cool mode (uses CCA and LED control)</p> <p>3 = bright mode (uses CCA and multi LED control)</p>
BRGP	Brightness Group. Identifies a subset of all projectors in the array to be used in the Array BCLOC algorithm. May be used to provide multiple groups of projectors with different color targets. (0-9999)
BRTG	Brightness Target. Sets the target brightness that the projectors in the array brightness group should meet. (0-1000 Lumens)
MINB	Minimum Brightness. Sets the minimum brightness, as a percentage of target brightness, that the projector will display if it is capable. (0-100 percent)
MING	Minimum Gamut. Sets the minimum gamut, as a percentage of the target gamut, that the projector will display if it is capable. (0-100 percent)
ADIN	Adjustment interval. Controls the interval in seconds that this projector will run the Array Bright/ColorLOC algorithm. (1-9999)
BRIN	Broadcast interval. Controls the interval in seconds that this projector will update the projector array. (1-9999)
ALBV	<p>When set, all projectors in brightness group will use this projectors settings:</p> <p>0 = OFF (normal)</p> <p>1 = synchronize to group</p> <p>Note: A group can synchronize to only one projector. Setting ABL+ABLV on any projector in a group to make that projector the master projector releases the setting from any previous master projector in the group.</p>

<b>(ABL) ARRAY BRIGHT COLOR LOC (CONTINUED)</b>	
DEVC	Specifies the ethernet port used for transfer of ColorLOC data. When selected will use the PHM network ethernet port rather than default EM network ethernet port. 0 = PHM network 1 = EM network
WENA	(FUTURE USE). Enable warnings associated with Bright/ColorLOC. 0 = disable 1 = enable
WBTH	(FUTURE USE). Sets the brightness threshold at which a warning is issued when warnings are enabled. (0-100 percent).
WGTH	(FUTURE USE). Sets the gamut threshold at which a warning is issued when warnings are enabled (0-100 percent).
IRTG	(FUTURE USE). IR Brightness Target. Sets the target brightness that the projectors in the array brightness group should meet. (0-1000).
DSEL	Allows selection of the Duty Cycle mode of operation: 0 = Automatic 1 = Preset
SKEY	Synchronize remote control keystrokes, test pattern and color enable amongst array projectors 0 = Independent 1 = Synchronized
SFRD	Synchronize frame delay amongst array projectors 0 = Independent 1 = Synchronized
AFRD	Sets the array frame delay parameter. Applies to all projectors in array if SFRD is set to Synchronized
AFRS	Read-only control reports smallest frame delay value in array that will not generate tearing artifacts
SRGB	Synchronize RGB Brightness setting amongst array projectors 0 = Independent 1 = Synchronized
SACF	Synchronize AccuFrame setting amongst array projectors 0 = Independent 1 = Synchronized
<p>EXAMPLES:</p> <p>(ABL+EABL 1) - Turn ON Array Bright/ColorLOC and run in Fixed mode</p> <p>(ABL+BRGP 2) - Set the brightness group to 2</p> <p>(ABL+BRTG 400) - Set the brightness target to 400 Lumens</p> <p>(ABL+ADIN ?) - Return current value of adjustment interval in seconds</p>	

<b>(ACE) AUTO COLOR ENABLE</b>	
CONTROL GROUP: Preference    SUBCLASS: Power Up    ACCESS LEVEL: Operator	
<b>DESCRIPTION</b> Automatically select Color Enable based on the control being adjusted. If enabled, this control allows the projector to automatically change the color enable control when the user is using the OSD interface to adjust controls such as Input levels, odd pixel, and brightness uniformity. This is an unsaved control, which can only be set when powered on, and only affects the operation of the On Screen Menus.	
<b>SUBCODE</b> <No Subcode >	<b>DESCRIPTION OF USE</b> Enable/Disable auto color controls.
<b>EXAMPLES:</b> (ACE 0) - Disable Auto Color (ACE 1) - Enable Auto Color	

<b>(ACF) ACCUFRAME</b>	
CONTROL GROUP: Preference    SUBCLASS: Power Up    ACCESS LEVEL: Operator	
<b>DESCRIPTION</b> This controls the settings for AccuFrame. AccuFrame is used to reduce image artifacts such as smearing and double image perception in high speed simulation environments.	
<b>SUBCODE</b> SLCT	<b>DESCRIPTION OF USE</b> Enable 0 = OFF 1 = ON
<b>PARAM</b>	Strength parameter which controls the effect of AccuFrame. Higher values will reduce artifacts, but will also reduce image brightness. Expressed as a percentage (0-100).
<b>EXAMPLES:</b> (ACF+SLCT 1) - Enable (ACF+PARAM 35) - Set strength to 35%	

<b>(ACO) ADAPTIVE CONTRAST</b>	
CONTROL GROUP: Input    SUBCLASS: Power Up    ACCESS LEVEL: Operator	
<b>DESCRIPTION</b> Adaptive Contrast Enhancement dynamically expands the contrast of the output image producing vibrant images with seamless response to scene changes and fades. The adaptive contrast function implements a dynamic non-linear mapping between the Input and output contrast levels based on frame-by-frame luminance histogram measurement of the Input image.	
<b>SUBCODE</b> INxy	<b>DESCRIPTION OF USE</b> Set the adaptive contrast for SlotSlot x, Input y. Range 0-15.
<b>MAIN</b>	Set the adaptive contrast for main video. Range 0-15.
<b>PIIP</b>	Set the adaptive contrast for PIP video. Range 0-15.



<b>(ACO) ADAPTIVE CONTRAST (Continued)</b>
<p>EXAMPLES:</p> <p>(ACO 8) - Sets adaptive contrast for main image to 50% strength.</p>

<b>(ACT) ACTIVE WINDOW</b>	
CONTROL GROUP: Input    SUBCLASS: Power Down    ACCESS LEVEL: Operator	
<p>DESCRIPTION</p> <p>This control defines the Input active window in pixels. The production aperture is available for analog sources only, but not for decoded analog signals. The aperture is set once on every auto setup or on new signal detection when a channel for that signal is not present. The aperture defines the maximum window in which blanking controls can be opened up to, relative to the active portion of the signal. This is a read only control.</p>	
SUBCODE INxy	DESCRIPTION OF USE Set the adaptive contrast for Slot x, Input y.
MAIN	Set the adaptive contrast for main video.
PIIP	Set the adaptive contrast for PIP video.
<p>EXAMPLES:</p> <p>(ACT?) - Returns the active window for main video.                  (ACT+PIIP?) - Returns the active window for PIP video.                  (ACT+IN12?) - Returns the active window for Slot 1 Input 2.</p>	

<b>(ADR) ADDRESS</b>	
CONTROL GROUP: Preference    SUBCLASS: Power Down    ACCESS LEVEL: Operator	
<p>DESCRIPTION</p> <p>Set/Query Device Address on ASCII Protocol network. Required only for RS-232 connections that are daisy chained to allow directed messages.</p>	
SUBCODE <No Subcode >	DESCRIPTION OF USE Valid Address range is 0 to 999. Reserved broadcast address is 65535.
<p>EXAMPLES:</p> <p>(65535 ADR 0) - Set all devices to address 0.                  (0 ADR 5) - Set first device at address 0 to address to 5.                  (65535 1001ADR?) - Query address for all devices and return results to address 1001.                  Expected response to previous query (01001 00005ADR!005).</p>	

<b>(AGC) AUTOMATIC GAIN CONTROL</b>	
CONTROL GROUP: Input    SUBCLASS: Power Down    ACCESS LEVEL: Advanced	
<p>DESCRIPTION</p> <p>Enable/disable the Automatic Gain Control. This control allows the decoder to automatically track the sync amplitude of the incoming signal. Turn this control OFF if you are experiencing strange color artifacts, indicating an incompatibility between the source and the AGC.</p>	

<b>(AGC) AUTOMATIC GAIN CONTROL (CONTINUED)</b>	
SUBCODE INxy	DESCRIPTION OF USE Set the AGC on Slot x, Input y to the specified state of either enable or disable.
MAIN	Set automatic gain control on main image.
PIIP	Set automatic gain control on main image.
EXAMPLES: (AGC 1) - Enables AGC on main video. (AGC+MAIN 0) - Disables AGC on main video. (AGC+PIIP 1) - Enables on PIP video. (AGC?) - Returns the current AGC state on main video. (AGC+PIIP ?) - Returns the current AGC state on PIP video. (AGC+IN12 ?) - Returns the current AGC state on Slot 1 Input 2.	

<b>(AIC) AUTO INPUT CYCLING</b>	
CONTROL GROUP: Preference    SUBCLASS: Power Down    ACCESS LEVEL: Operator	
DESCRIPTION When enabled, the system will continually search for the next valid signal when no signal is present or when loss of sync occurs on the current user selected Input. In the case of multiple signals to choose from, the order is based on Slot, followed by Inputs on that Slot.	
SUBCODE <No Subcode >	DESCRIPTION OF USE Enable or disable auto Input cycling.
EXAMPLES: (AIC 0) - Disable auto Input cycling. (AIC 1) - Enable auto Input cycling.	

<b>(AIL) AUTO INPUT LEVEL</b>	
CONTROL GROUP: Unsaved    SUBCLASS: Power Up    ACCESS LEVEL: Operator	
DESCRIPTION If enabled, this control allows the projector to continuously monitor the Input signal levels of the analog Inputs and make adjustments as needed. Whenever the projector detects a level that would lead to the crushing of black or white levels, it adjusts the Input offset or gain to compensate. If the Input signal is not being crushed, the projector will do nothing. The Auto Input Level feature should only be used when the current source requires further Input level adjustment. There must be at least 12 consecutive white pixels in the image in order to use Auto Input Levels. The monitor period will run for 10 seconds after being issued. Auto setup or source switching will stop the level period. To use this control, turn the Auto Input Level feature ON, wait for the blacklevel and drive values to stabilize, and turn the Auto Input Level feature off or wait for the 10 seconds. When the Auto Input Level feature is turned OFF, the current drive and blacklevel values are maintained. This control only applies to analog BNC or Dual DVI cards.	
SUBCODE MAIN	DESCRIPTION OF USE Perform auto Input level on the main image.
PIIP	Perform auto Input level on the PIP image.

**(AIL) AUTO INPUT LEVEL**

EXAMPLES:  
 (AIL 1) - Perform auto Input level on the main image.  
 (AIL+PIIP 1) - Perform auto Input level on the PIP image.

**(ALT) ACTIVE LOOP-THROUGH**

CONTROL GROUP: Preference    SUBCLASS: Power Down    ACCESS LEVEL: Operator

DESCRIPTION  
 In situations where a Twin HDMI Input card is being used to loop signals out to another projector, this feature ensures that video signals continue to be looped out when the projector enters Standby power mode. Note that when the projector is in Standby mode (and this feature is enabled), limited channel control is available - inputs can be switched, can perform Auto Setup and some limited input settings can be modified.

SUBCODE <No Subcode>	DESCRIPTION OF USE Enable or disable active loop-through.
-------------------------	--

EXAMPLES:  
 (ALT 1) - Enables Standby active loop-through.  
 (ALT 0) - Disables Standby active loop-through.  
 (ALT?) - Gets the current Standby active loop-through setting.

**(APJ) ACTIVE PROJECTOR**

CONTROL GROUP: Input    SUBCLASS: Power Down    ACCESS LEVEL: Operator

DESCRIPTION  
 Temporarily enable or disable the IR and wired keypad Inputs to a specific projector in a network of projectors. When a projector is disabled, the only key that works is PROJ. The next time the projector is powered up again, it will revert to fully enabled. The built-in keypad will always be fully functional. This control does not overwrite the Front IR, Back IR and Wired Keypad settings.

SUBCODE <No Subcode >	DESCRIPTION OF USE Set 0 to temporarily disable keypad access to this projector.
--------------------------	---

EXAMPLES:  
 (APJ 1) - Projector is active (keypads are enabled).  
 (APJ 0) - Projector is not active (keypads are temporarily disabled).  
 (APJ?) - Is the projector keypad active or not.

**(APW) AUTO POWER UP**

CONTROL GROUP: Preference    SUBCLASS: Power Down    ACCESS LEVEL: Operator

DESCRIPTION  
 When the A/C switch is turned ON, the projector will automatically change from Stand-by Mode to Power ON Mode. The projector will switch the lamp(s) on without waiting for further user actions.

SUBCODE <No Subcode >	DESCRIPTION OF USE Set to 1 to enable.
--------------------------	---

EXAMPLES:

- (APW 0) - Projector will remain in Standby Mode until the user presses the power key.
- (APW 1) - Projector will auto power up when A/C power is switched on.

**(ARO) ASPECT RATIO OVERLAY**

CONTROL GROUP: Unsaved    SUBCLASS: Power Up    ACCESS LEVEL: Operator

DESCRIPTION

Enables or disables Aspect Ratio layer over Image layer.

SUBCODE

<No Subcode >

DESCRIPTION OF USE

EXAMPLES:

- (ARO 1) - Turns ON Aspect Ratio Overlay.
- (ARO 0) - Turns OFF Aspect Ratio Overlay.

**(ASH) AUTO SHUTDOWN**

CONTROL GROUP: Saved    SUBCLASS: Power Down    ACCESS LEVEL: Operator

DESCRIPTION

When Auto Shutdown Mode has been selected, and no projector activity has been seen for the activation time-out period, the projector will enter a Power Saving mode in which the lamps will dim and the shutter close. If this condition persists for an additional time-out period the projector will automatically go to standby. The presence of any activity within this is combined interval will cancel Auto Shutdown and return the projector to normal operation.

SUBCODE

<No Subcode >

DESCRIPTION OF USE

Enable or disable Auto Shutdown Operation.

SBTO

Set the uninterrupted time-out period that must elapse before projector will enter Standby Mode (The second time-out period or Standby time-out).

ALTO

Set the uninterrupted time-out period that must elapse time of activity loss until Auto Shutdown is activated (The first time-out period or Activation time-out).

EXAMPLES:

- (ASH 1) - Turns ON Auto Shutdown Mode.
- (ASH 0) - Turns OFF Auto Shutdown Mode.
- (ASH+SBTO 10) - Sets standby time-out to 10 minutes.
- (ASH+ALTO 10) - Sets source activity loss time-out to 10 minutes.

(ASR) AUTO CHANNEL SELECT	
CONTROL GROUP: Channel    SUBCLASS: Power Down    ACCESS LEVEL: Operator	
<p>DESCRIPTION</p> <p>The Auto Channel Select (ASR) option allows the projector to select the channel memory best suited to the Input signal. If the current channel does not allow Auto Channel Select, the projector will not attempt to select a new channel when the signal changes. If the current channel does allow Auto Channel Select, then upon signal detection, an existing channel will be chosen. If a match is not found a new channel will be created.</p>	
SUBCODE C0xx	DESCRIPTION OF USE Enable/disable Auto Channel Select on channel (xx=channel number from 01 to 99).
MAIN	Enable/disable Auto Channel Select on the channel being used by main.
PIIP	Enable/disable Auto Channel Select on the channel being used by PIP.
<p>EXAMPLES:</p> <p>(ASR?) - Get Auto Channel Select state for channel being used by main.                      (ASR+MAIN?) - Get Auto Channel Select state for channel being used by main.                      (ASR+PIIP?) - Get Auto Channel Select state for channel being used by PIP.                      (ASR 1) - Enable Auto Channel Select for the channel being used by main.                      (ASR+PIIP 1) - Enable Auto Channel Select for the channel being used by PIP.                      (ASR+MAIN 0) - Disable Auto Channel Select for the channel being used by main.                      (ASR+C001 0) - Disable Auto Channel Select for channel 1.</p>	

(ASU) AUTO SETUP	
CONTROL GROUP: Unsaved    SUBCLASS: Power Down    ACCESS LEVEL: Operator	
<p>DESCRIPTION</p> <p>This control tells the projector to automatically adjust as many parameters as it can to produce the optimal setup for the current input.</p> <p><b>NOTE:</b> If main and PIP video are using the same channel, the Auto Setup will act on both, regardless of the sub-code being used.</p> <p>In some cases for analog video, the user can select the format that best suits their source. This selection helps the Auto Setup get the correct settings for the tracking and phase controls for analog sources that contain the same number of active lines, but have a different aspect ratios.</p> <ul style="list-style-type: none"> <li>• All digital and decoder option cards do not allow options for auto setup since digital hardware provides enough information to perform the correct auto setup.</li> <li>• Analog PC graphics sources (4/5-wire sync) present a list of formats based on the current active lines detected in the video.</li> <li>• Analog Video Sources (3 wire sync on green) always have the options ‘Default’ and ‘Advanced’. Video sources use a look up table to determine their format based on video standards. The ‘Advanced’ Auto Setup selection measures the start pixel and start line whereas ‘Default’ uses the table values as is.</li> </ul>	
SUBCODE MAIN	DESCRIPTION OF USE Perform a standard Auto Setup on the main video.

PIIP	Perform a standard Auto Setup on the picture-in-picture (PIP) video.
<p>EXAMPLES:</p> <p>(ASU) - Perform standard Auto Setup on main video.</p> <p>(ASU+MAIN) - Perform standard Auto Setup on main video.</p> <p>(ASU+PIIP) - Perform standard Auto Setup on PIP.</p>	

**(BBL) BOTTOM BLANKING**

CONTROL GROUP: Input    SUBCLASS: Power Down    ACCESS LEVEL: Operator	
<p>DESCRIPTION</p> <p>Set the number of lines to blank (turn to black) at the bottom of the image. This can be used to blank out any unwanted data near the bottom edge of the image.</p> <p>A positive amount of blanking makes the image smaller. A negative amount of blanking makes the image larger. Negative blanking is only applicable to analog signals, when the Auto Setup has not been able to set the image size correctly. It is preferable not to use negative blanking, but to run Auto Setup again, ensuring that the content has active pixels on each edge of the image.</p> <p>The maximum amount of bottom blanking allowed is half the image height minus 10. For negative blanking, the image size can only be increased to the limit of the sync.</p>	
SUBCODE	DESCRIPTION OF USE
IN <sub>xy</sub>	Set the bottom blanking for Slot X, Input Y.
MAIN	Set the bottom blanking for the main image.
PIIP	Set the bottom blanking for the PIP image.
<p>EXAMPLES:</p> <p>(BBL 40) - Set bottom blanking to 40 on main video.</p> <p>(BBL+MAIN 40) - Set bottom blanking to 40 on main video.</p> <p>(BBL+PIIP 40) - Set bottom blanking to 40 on PIP video.</p> <p>(BBL+IN32 40) - Set bottom blanking to 40 on Slot 3 Input 2.</p> <p>(BBL?) - Returns the bottom blanking value on main video.</p> <p>(BBL+PIIP?) - Returns the bottom blanking value on PIP video.</p> <p>(BBL+IN12?) - Returns the bottom blanking value on Slot 1 Input 2.</p>	

**(BDR) BAUD RATE**

CONTROL GROUP: Preference    SUBCLASS: Power Down    ACCESS LEVEL: Advanced									
<p>DESCRIPTION</p> <p>Set the baud rate for a serial communications port. For RS-232 IN and RS-232 OUT, the default is 115200. For RS-422, the default is 19200. The default communications settings for all ports is 8 data bits, no parity. Valid baud rates, with the values to select them, are:</p> <table style="width: 100%; border: none;"> <tr> <td style="width: 50%;">0 = 1200</td> <td style="width: 50%;">4 = 38400</td> </tr> <tr> <td>1 = 2400</td> <td>5 = 57600</td> </tr> <tr> <td>2 = 9600</td> <td>6 = 115200</td> </tr> <tr> <td>3 = 19200</td> <td></td> </tr> </table>		0 = 1200	4 = 38400	1 = 2400	5 = 57600	2 = 9600	6 = 115200	3 = 19200	
0 = 1200	4 = 38400								
1 = 2400	5 = 57600								
2 = 9600	6 = 115200								
3 = 19200									

<b>(BDR) BAUD RATE (CONTINUED)</b>	
SUBCODE	DESCRIPTION OF USE
PRTA	Set the baud rate on port A (RS-232 IN).
PRTB	Set the baud rate on port B (RS-232 OUT).
PRTC	Set the baud rate on port C (RS-422).
EXAMPLES: (BDR+PRTA 6) - Set baud rate on port A to 115200 bits per second. (BDR+PRTA?) - Get baud rate (BDR+PRTA!"115200").	

<b>(BGC) BASE GAMMA CURVE</b>	
CONTROL GROUP: Input    SUBCLASS: Power Down    ACCESS LEVEL: Operator	
DESCRIPTION This control lets you select the Gamma table. You can select from one of the standard tables, or select an arbitrary Gamma table that has been downloaded into the projector. A separate PC utility is needed to do this. The 2.22 table is a simple power curve. The standard table is a modified 2.22 curve with an optimized linear portion in the low end of the curve. This is the same as selecting a custom table and setting the function to be 2.22 and the slope to be 1.0. Selecting Gamma Function from the drop down list enables the Gamma Function and Gamma Slope controls. Valid values are: 0 = Standard 1 = 2.22 2 = Gamma Function	
SUBCODE	DESCRIPTION OF USE
IN <sub>xy</sub>	Set the base gamma curve for Slot x, Input y.
MAIN	Set the base gamma curve for main video.
PIIP	Set the base gamma curve for PIP video.
EXAMPLES: (BGC 0) - Set main video to the standard base gamma table. (BGC+MAIN 0) - Set main video to the standard base Gamma table. (BGC+IN32 0) - Set Slot 3 Input 2 to the standard base Gamma table.	

<b>(BGF) BASE GAMMA FUNCTION</b>	
CONTROL GROUP: Input    SUBCLASS: Power Up    ACCESS LEVEL: Operator	
DESCRIPTION Defines the gamma power curve to be used when the Gamma table value is set to 'Gamma Function'. This value, combined with Gamma Slope setting, determines the Gamma table to be used. The curve is generally a power curve with a small linear segment at the bottom defined by the slope. The valid range is 100-300, where 100 is 1.0 linear and 300 is a 3.00 power curve.	
SUBCODE	DESCRIPTION OF USE
IN <sub>xy</sub>	Set the base gamma curve for Slot x, Input y.
MAIN	Set the base gamma curve for main video.

<b>(BGF) BASE GAMMA FUNCTION (CONTINUED)</b>	
PIIP	Set the base gamma curve for PIP video.
EXAMPLES: (BGF 100) - Set the base Gamma Function to 1.0 for main video. (BGF+MAIN 300) - Set the base Gamma Function to 3.0 for main video. (BGF+IN32 222) - Set the base Gamma Function to 2.22 for Slot 3, Input 2.	

<b>(BGS) BASE GAMMA SLOPE</b>	
CONTROL GROUP: Input    SUBCLASS: Power Up    ACCESS LEVEL: Operator	
DESCRIPTION Defines the slope to be used for the base custom Gamma table in the small linear section at the bottom of the curve. This slope can be used to bring the low level blacks in the image in or out. This slope, combined with the Gamma function, defines the custom Gamma table. The valid range is 50-200, where 50 is a slope of 0.5 and 200 is a slope of 2.00.	
SUBCODE	DESCRIPTION OF USE
INxy	Set the base gamma curve for Slot x, Input y.
MAIN	Set the base gamma curve for main video.
PIIP	Set the base gamma curve for PIP video.
EXAMPLES: (BGS 100) - Set the base gamma slope to 1.0 for main video. (BGS+MAIN 200) - Set the base gamma slope to 2.0 for main video. (BGS+IN32 150) - Set the base gamma slope to 1.5 for Slot 3, Input 2.	

<b>(BKY) BROADCAST KEY MODE</b>	
CONTROL GROUP: Preference    SUBCLASS: Power Down    ACCESS LEVEL: Operator	
DESCRIPTION Toggle Broadcast Key Mode to select whether all key presses received by the projector will be relayed to all other projectors on the network.	
SUBCODE	DESCRIPTION OF USE
<No Subcode >	Set to 1 to enable.
EXAMPLES: (BKY 1) - Enable Broadcast Key. (BKY 0) - Disable Broadcast Key. (BKY?) - Get current Broadcast key state.	



<b>(BLB) BLUE BLACK LEVEL</b>	
CONTROL GROUP: Input    SUBCLASS: Power Down    ACCESS LEVEL: Operator	
<p>DESCRIPTION</p> <p>Blue black level is used to compensate for relative variations in the black levels between Red, Green and Blue. This is available on all cards except the Video decoder.</p> <p>The correct setting achieves maximum contrast without crushing white or black. When the drive and black level controls are set correctly for a signal, the Comprehensive Color Adjustment, including color temperature, will work as expected. The drive and black level controls should not be used to setup a specific color temperature as this will require separate color temperature adjustments to be made for each signal.</p>	
SUBCODE INxy	DESCRIPTION OF USE Set the blue black level on Slot x, Input y to the specified value in the range of -255 to 255.
MAIN	Set the blue black level on the main video to the specified value in the range -255 to 255.
PIIP	Set the blue black level on the PIP video to the specified value in the range of -255 to 255.
<p>EXAMPLES:</p> <p>(BLB 128) - Set blue black level to 128 on main video.            (BLB+MAIN 128) - Set blue black level to 128 on main video.            (BLB+PIIP 100) - Set blue black level to 100 on PIP video.            (BLB+IN32 100) - Set blue black level to 100 on Slot 3, Input 2.            (BLB?) - Returns the current blue black level value on main video.            (BLB+PIIP ?) - Returns the current blue black level value on PIP video.            (BLB+IN12 ?) - Returns the current blue black level value on Slot 1, Input 2.</p>	

<b>(BLD) BLUE DRIVE</b>	
CONTROL GROUP: Input    SUBCLASS: Power Down    ACCESS LEVEL: Operator	
<p>DESCRIPTION</p> <p>The blue drive level is used to compensate for different amounts of attenuation between the Red, Green and Blue in the signal. This is available on all cards except the Video decoder.</p> <p>The correct setting achieves maximum contrast without crushing white or black. When the drive and black level controls are set correctly for a signal, the Comprehensive Color Adjustment, including color temperature, will work as expected. The drive and black level controls should not be used to setup a specific color temperature as this will require separate color temperature adjustments to be made for each source.</p>	
SUBCODE INxy	DESCRIPTION OF USE Set the blue drive on Slot x, Input y to the specified value in the range of -255 to 255.
MAIN	Set the blue drive on the main video to the specified value in the range -255 to 255.
PIIP	Set the blue drive on the PIP video to the specified value in the range of -255 to 255.

<b>(BLD) BLUE DRIVE (CONTINUED)</b>
<p>EXAMPLES:</p> <p>(BLD 128) - Set blue drive to 128 on main video.</p> <p>(BLD+MAIN 128) - Set blue drive to 128 on main video.</p> <p>(BLD+PIIP 100) - Set blue drive to 100 on PIP video.</p> <p>(BLD+IN32 100) - Set blue drive to 100 on Slot 3 Input 2.</p> <p>(BLD?) - Returns the current blue drive value on main video.</p> <p>(BLD+PIIP?) - Returns the current blue drive value on PIP video.</p> <p>(BLD+IN12?) - Returns the current blue drive value on Slot 1 Input 2.</p>

<b>(BOG) BLUE ODD PIXEL GAIN</b>	
CONTROL GROUP: Option    SUBCLASS: Power Up    ACCESS LEVEL: Operator	
DESCRIPTION This adds an offset to Input blue gain settings on the analog Input card. It is used to compensate for differences between the A to D converter used to sample even pixels, and the one used for odd pixels. A value of 0 is the null position in which both A to D converters are set to exactly the same value.	
SUBCODE SLx0	DESCRIPTION OF USE Set a blue gain offset for the second A to D.
EXAMPLES: (BOG+SL10 -10) - Set a blue gain offset to -10 on Slot 1.	

<b>(BOO) BLUE ODD PIXEL OFFSET</b>	
CONTROL GROUP: Option    SUBCLASS: Power Up    ACCESS LEVEL: Operator	
DESCRIPTION This adds an offset to Input blue black level settings on the analog Input card. It is used to compensate for differences between the A to D converter used to sample even pixels, and the one used for odd pixels. A value of 0 is the null position in which both A to D converters are set to exactly the same value.	
SUBCODE SLx0	DESCRIPTION OF USE Set a blue black level offset for the second A to D.
EXAMPLES: (BOO+SL10 -10) - Set a blue black level offset to -10 on Slot 1.	

<b>(BRT) BRIGHTNESS</b>	
CONTROL GROUP: Input    SUBCLASS: Power Down    ACCESS LEVEL: Operator	
DESCRIPTION The Brightness control adjusts the offset applied to the Input signal. It has exactly the same effect as adjusting the Input levels, except that it operates on all 3 colors and can be used to make quick adjustments. For precise control, the Input level adjustments should be used. If the setting is too high, black portions of the image are displayed as dark grey, making the image appear washed-out. If the setting is too low, dark greys are displayed as deep black and detail is lost in the darkest parts of the image. This condition is known as 'crushing'. When adjusting, start from a lower setting and adjust upwards until just above the point where black is crushed.	
SUBCODE INxy	DESCRIPTION OF USE Set the brightness on Slot x, Input y to the specified value in the range of -1000 to 1000.
MAIN	Set the brightness on the main video to the specified value in the range -1000 to 1000.
PIIP	Set the brightness on the PIP video to the specified value in the range of -1000 to 1000.
EXAMPLES: (BRT 500) - Set brightness to 500 on main video (BRT+MAIN 500) - Set brightness to 500 on main video. (BRT+PIIP -250) - Set brightness to -250 on PIP video. (BRT+IN32 100) - Set brightness to 100 on Slot 3, Input 2. (BRT?) - Returns the current brightness value on main video. (BRT+PIIP ?) - Returns the current brightness value on PIP video. (BRT+IN12 ?) - Returns the current brightness value on Slot 1, Input 2.	

<b>(BRU) BRIGHTNESS UNIFORMITY</b>	
CONTROL GROUP: Preference    SUBCLASS: Power Down    ACCESS LEVEL: Operator	
DESCRIPTION Enable/Disable brightness uniformity and adjust brightness uniformity output.	
SUBCODE SLCT	DESCRIPTION OF USE Enable/Disable Brightness Uniformity.
CRSA	Enable/Disable BRU Coarse Adjustment.
UITL	Get/Set the percent of gain at top left corner.
UIML	Get/Set the percent of gain at left side.
UIBL	Get/Set the percent of gain at bottom left corner.
UITR	Get/Set the percent of gain at top right corner.
UIMR	Get/Set the percent of gain at right side.
UIBR	Get/Set the percent of gain at bottom right corner.
UIH1	Get/Set the percent of gain at left turn point.

<b>(BRU) BRIGHTNESS UNIFORMITY (CONTINUED)</b>	
UIH2	Get/Set the percent of gain at right turn point.
UI1P	Get/Set position of left turn point.
UI2P	Get/Set position of right turn point.
GAIN	Get/Set overall gain.
UIRT	Restore all parameters to factory default.
EXAMPLES: (BRU+SLCT?) - Get current state of brightness uniformity, 0 is disabled, 1 is enabled. (BRU+SLCT 1) - Enable brightness uniformity.	

<b>(CCD) OUTPUT COLOR DEFAULT</b>	
CONTROL GROUP: Preference    SUBCLASS: Power Up    ACCESS LEVEL: Operator	
DESCRIPTION Specifies the default color adjustment to use for new channels. This allows the user to specify a standard color and have that color applied by default to all new sources. The user may override this for any specific channel. Using the default subcode applies a default to be used when creating a new channel using auto setup while the YNF is not in the video path. Using the subcode DYNF allows a different color table default to be specified while the YNF is in the video path during auto setup.	
SUBCODE	DESCRIPTION OF USE
<No Subcode >	Apply a default table to use while running auto setup when a YNF filter is not in place.
DYNF	Apply a default table to use while running auto setup when a YNF filter is in place.
EXAMPLES: (CCD 0) - Make new channels using the MAX drive table, while running auto setup and YNF is out. (CCD+DYNF 4) - Make new channels using the HD table, while running auto setup and YNF is in.	

<b>(CCI) INTERPOLATED COLOR</b>	
CONTROL GROUP: Input    SUBCLASS: Power Up    ACCESS LEVEL: Operator	
DESCRIPTION This control generates an output color map based on interpolating the values for the standard color temperatures in the range of 3200K-9300K. It effectively allows you to adjust the color temperature of the image. The selected output color table must be on 'Color Temperature' to enable this control.	
SUBCODE	DESCRIPTION OF USE
INxy	Set the interpolated color temperature for Slot x, Input y.
MAIN	Set the interpolated color temperature for main video.
PIIP	Set the interpolated color temperature for PIP video.
EXAMPLE: (CCI 9300) - Set the interpolated color temperature to 9300K for main video.	

<b>(CCS) SELECT OUTPUT COLOR</b>	
CONTROL GROUP: Input    SUBCLASS: Power Down    ACCESS LEVEL: Operator	
<p>DESCRIPTION</p> <p>Selects which of several predefined and 4 user defined color maps to use for a specific Input signal.</p> <p>0 = MaxDrives - All color adjustments are turned off allowing the projector to run at maximum brightness.</p> <p>1 = Color Temperature - This will allow you to specify a color temperature between 3200 and 9300 based on the setting of the Color Temperature control. Color temperature is expressed in degrees Kelvin [3200, 5400, etc.].</p> <p>Lower numbers give a reddish white, higher numbers appear bluish. There are 4 standard settings. 9300K is close to the white of many computer monitors. 6500K is the standard for color video, in both standard- and high-definition forms. 5400K is a standard for graphics and black-and-white video. 3200K is useful if the projected image is to be filmed or shot as part of a studio set that is illuminated with incandescent lights. For all color temperatures, the color primaries [red, green &amp; blue] are unchanged and reflect the native colors of the projector.</p> <p>2 = SD Video - Optimized for SD video. This will allow you to adjust the color of red, green and blue, as well as the color white.</p> <p>3 = HD Video - Optimized for HD video. This will allow you to adjust the color of red, green and blue, as well as the color of white.</p> <p>4 = User 1 - Selects a user defined sets of color adjustments.</p> <p>5 = User 2 - Selects a user defined sets of color adjustments.</p> <p>6 = User 3 - Selects a user defined sets of color adjustments.</p> <p>7 = User 4 - Selects a user defined sets of color adjustments.</p> <p>The set of 4 User Defined settings are defined in the configuration menu.</p>	
SUBCODE	DESCRIPTION OF USE
INxy	Select the color temp setting for Slot x, Input y.
MAIN	Select the color temp setting for main video.
PIIP	Select the color temp setting for PIP video.
<p>EXAMPLE:</p> <p>(CCS 0) - Set the color temp setting to max drives for main video.</p>	

<b>(CHA) CHANNEL</b>	
CONTROL GROUP: Unsaved    SUBCLASS: Power Up    ACCESS LEVEL: Operator	
<p>DESCRIPTION</p> <p>Select the channel to use, in the range 1-99. Switching channels will switch to the appropriate option card/Input. If the signal signature in the channel does not match the signal on the channel's Input, the channel change will switch to the "auto-channel" or to the channel that was defined for the signal signature that is on the channel's Input. This command will fail if the data in the channel file does not match the current system hardware. This command can also be used to copy, delete and edit certain channel properties.</p>	
SUBCODE	DESCRIPTION OF USE
COPY	Make a copy of a channel, and assign it a unique number (optionally, specify a new channel number).
DLET	Delete a channel.
MAIN	Set the channel being used by main.

<b>(CHA) CHANNEL (CONTINUED)</b>	
PIIP	Set the channel being used by PIP.
INFO	Display the information on the current channel.
<p>EXAMPLES:</p> <p>(CHA?) - Get current active channel.                      (CHA 10) - Set main to channel 10.                      (CHA+PIIP 99) - Set PIP to channel 99.                      (CHA+COPY 1) - Make a copy of channel 1, using the next free channel number.                      (CHA+COPY 1 20) - Make a copy of channel 1, and copy to channel 20 (will fail if 20 already exists).                      (CHA+DLET 0) - Delete all unlocked channels.                      (CHA+DLET 20) - Delete channel 20.</p>	

<b>(CLE) COLOR ENABLE</b>	
CONTROL GROUP: Unsaved    SUBCLASS: Power Up    ACCESS LEVEL: Operator	
<p>DESCRIPTION</p> <p>This control allows the three primary colors (red, green, and blue) to be turned ON or OFF separately. It is used to look at the colors one at a time or in pairs when doing convergence, light measurements, etc. The list of values for this command are:</p> <p>0 = White                      4 = Yellow                      1 = Red                        5 = Cyan                      2 = Green                     6 = Magenta                      3 = Blue</p>	
SUBCODE	DESCRIPTION OF USE
<No Subcode >	
<p>EXAMPLES:</p> <p>(CLE 1) - Display red portion of image only.                      (CLE 5) - Display green and blue portion of image only.                      (CLE 0) - Display image normally (all primaries).</p>	

<b>(CLP) CLAMPING</b>	
CONTROL GROUP: Input    SUBCLASS: Power Up    ACCESS LEVEL: Operator	
<p>DESCRIPTION</p> <p>For all analog signals a clamping pulse is generated that defines where in the signal a black reference can be found. The Clamp Location sets the clamping pulse to one of three possible locations: tip, back porch &amp; tri-level. For most signals the correct position is backporch, just after the sync pulse. If the signal has no back porch and there is no sync pulse in the RG or B signals, clamping can occur at the front or tip of the sync pulse. For HDTV signals [1080i &amp; 720p] the clamp must be moved past the positive pulse of the tri-level sync pulse, so the tri-level option is correct. For almost all other signals, backporch is correct. Sync tip is needed only if the backporch is too small. For many signals, this control will have no effect. Change this setting only if the image appears unusually dim, has horizontal streaks, or shows significant color drift.</p>	

<b>(CLP) CLAMPING (CONTINUED)</b>	
Value Range: 0 = sync tip 1 = backporch 2 = tri-level	
SUBCODE INxy	DESCRIPTION OF USE Set the black level clamping for Slot x, Input y.
MAIN	Set the black level clamping for main video.
PIIP	Set the black level clamping for PIP video.
EXAMPLES: (CLP 0) - Set the black level clamping for main video to sync tip. (CLP+MAIN 0) - Set the black level clamping for main video to sync tip. (CLP+IN32 0) - Set the black level clamping for Slot 3 Input 2 to sync tip.	

<b>(CLR) COLOR</b>	
CONTROL GROUP: Input    SUBCLASS: Power Up    ACCESS LEVEL: Operator	
DESCRIPTION This control adjusts the saturation (amount) of color in a video image.	
SUBCODE INxy	DESCRIPTION OF USE Set the color saturation on Slot x, Input y to the specified value in the range of 0-1000.
MAIN	Set the color saturation on the main video to the specified value in the range 0-1000.
PIIP	Set the color saturation on the PIP video to the specified value in the range of 0-1000.
EXAMPLES: (CLR 500) - Set color saturation to 500 on Main video. (CLR+MAIN 500) - Set color saturation to 500 on Main video. (CLR+PIP 250) - Set color saturation to 250 on PIP video. (CLR+IN32 100) - Set color saturation to 100 on Slot 3, Input 2. (CLR ?) - Returns the current color saturation value on Main video. (CLR+PIP ?) - Returns the current color saturation value on PIP video. (CLR+IN12 ?) - Returns the current color saturation value on Slot 1, Input 2.	

<b>(CNM) CHANNEL INFO: NUMBER</b>	
CONTROL GROUP: Channel    SUBCLASS: Power Up    ACCESS LEVEL: Operator	
DESCRIPTION This control is used to edit the channel index number.	

SUBCODE C0xx	DESCRIPTION OF USE Select a new number for channel (xx=channel number from 01 to 99).
EXAMPLE: (CNM+C001 3) - Change the channel number from 1 to 3.	

**(CON) CONTRAST**

CONTROL GROUP: Input    SUBCLASS: Power Down    ACCESS LEVEL: Operator	
DESCRIPTION This control sets the image contrast by adjusting the gain applied to the Input signal. It has exactly the same effect as adjusting the Input levels, except that it operates on all 3 colors and can be used to make quick adjustments. For precise control, the Input level adjustments should be used. If the setting is too high, bright portions of the image that are not quite at peak white are displayed as peak white and detail is lost in the brightest parts of the image. This condition is known as 'crushing'. If the setting is too low, the image will be dimmer than it needs to be. Start from a lower setting and adjust upwards until just below the point where white is crushed.	
SUBCODE INxy	DESCRIPTION OF USE Set the contrast on Slot x, Input y to the specified value in the range of 0-1000.
MAIN	Set the contrast on the main video to the specified value in the range 0-1000.
PIIP	Set the contrast on the PIP video to the specified value in the range of 0-1000.
EXAMPLES: (CON 500) - Set contrast to 500 on Main video. (CON+MAIN 500) - Set contrast to 500 on Main video. (CON+PIIP 250) - Set contrast to 250 on PIP video. (CON+IN32 100) - Set contrast to 100 on Slot 3, Input 2. (CON?) - Returns the current contrast value on Main video. (CON+PIIP ?) - Returns the current contrast value on PIP video. (CON+IN12 ?) - Returns the current contrast value on Slot 1, Input 2.	

**(CRM) CHROMA/LUMA DELAY**

CONTROL GROUP: Input    SUBCLASS: Power Up    ACCESS LEVEL: Operator	
DESCRIPTION Chroma/Luma delay adjusts the time delay between the chroma and the luminance signals in decoded signals. Adjust the delay to eliminate shadows occurring with adjacent colors. It is useful only for video images processed by decoder cards.	
SUBCODE INxy	DESCRIPTION OF USE Set the luma delay on Slot x, Input y to the specified value in the range of -3 pixel to 3 pixel.



<b>(CRM) CHROMA/LUMA DELAY (CONTINUED)</b>	
MAIN	Set the luma delay on the main video to the specified value in the range -3 pixel to 3 pixel.
PIIP	Set the luma delay on the PIP video to the specified value in the range of -3 pixel to 3 pixel.
<p>EXAMPLES:</p> <p>(CRM 3) - Set luma delay to 3 pixel on Main video.                      (CRM+MAIN 3) - Set luma delay to 3 pixel on Main video.                      (CRM+PIIP 3) - Set luma delay to 3 pixel on PIP video.                      (CRM+IN32 -3) - Set luma delay to -3 pixel on Slot 3, Input 2.                      (CRM ?) - Returns the current luma delay on Main video.                      (CRM+PIIP ?) - Returns the current luma delay on PIP video.                      (CRM+IN12 ?) - Returns the current luma delay on Slot 1, Input 2.</p>	

<b>(CSP) COLOR SPACE</b>	
CONTROL GROUP: Input    SUBCLASS: Power Down    ACCESS LEVEL: Operator	
<p>DESCRIPTION</p> <p>This control specifies which color space the Input signal uses. This determines how the color components are decoded for accurate color in the display. Color space control only applies to analog Input signals. Although the proper color space is normally determined automatically by the projector, you can override the setting. Use RGB unless you are using component video. Use YPbPr(SDTV) for most video sources. Use YPbPr(HDTV) for high definition signals.</p>	
<p><b>NOTE:</b> When certain RGB signals are first connected, the projector may not initially recognize them as RGB and may incorrectly decode their color information as YPbPr(SDTV). These signals can include: RGB signals in NTSC, PAL, SECAM frequency ranges, Scan-doubled sync-on-green, Scan-quadrupled sync-on-green. For these signals, change the Color Space to RGB, then define a new channel for future use. Values are:</p> <p>0 = RGB                      1 = YPbPr (SDTV)                      2 = YPbPr (HDTV)</p>	
SUBCODE	DESCRIPTION OF USE
IN <sub>xy</sub>	Set the color space on Slot x, Input y.
MAIN	Set the color space on Main video.
PIIP	Set the color space on PIP video.
<p>EXAMPLES:</p> <p>(CSP 1) - Set color space to YPbPr(SDTV) on Main video.                      (CSP+MAIN 2) - Set color space to YPbPr(HDTV) on Main video.                      (CSP+PIIP 1) - Set color space to YPbPr(SDTV) on PIP video.                      (CSP+IN32 1) - Set color space to YPbPr(SDTV) on Slot 3, Input 2.                      (CSP?) - Returns the current color space value on Main video.                      (CSP+PIIP?) - Returns the current color space value on PIP video.                      (CSP+IN12?) - Returns the current color space value on Slot 1, Input 2.</p>	

<b>(DED) DUAL DVI EDID TYPE SELECTION</b>	
CONTROL GROUP: Option    SUBCLASS: Power Up    ACCESS LEVEL: Operator	
DESCRIPTION Set the preferred EDID Timings on the Dual DVI Input card. Available Models are: 0 = Default 1 = 3D 2 = Custom <b>NOTE:</b> 3D option (1) is not supported for Entero or Matrix StIM/SIM.	
SUBCODE SLxy	DESCRIPTION OF USE Set the EDID timings on Slot x to the specified type.
EXAMPLES: (DED+SL31 2) - Set EDID type to 2 (Custom) on Slot 3, Input 1. (DED+SL12 ?) - Returns the current EDID type on Slot 1, Input 2.	

<b>(DLG) DATA LOGGING</b>	
CONTROL GROUP: Preference    SUBCLASS: Power Down    ACCESS LEVEL: Operator	
DESCRIPTION Set data logging level. 0 = Minimal logging of activities. Logging system errors, warnings and 'events' (i.e. power ON/OFF, lamp ON/OFF, user login/logout). 1 = Normal logging. Most activities logged - errors, warnings, events, and other info. 2 = Debug logging. All activities are logged.	
SUBCODE <No Subcode >	DESCRIPTION OF USE There are 3 levels for data logging.
EXAMPLES: (DLG1) - Set current logging level to 1. (DLG?) - Get current logging level. Response is (DLG!001).	

<b>(DTL) DETAIL</b>	
CONTROL GROUP: Input    SUBCLASS: Power Down    ACCESS LEVEL: Operator	
DESCRIPTION This control adjusts the sharpness of the image. The sharpness detail enhancement applied is based on adaptive horizontal, vertical and diagonal large edge and small edge enhancement processes. Setting detail above the halfway-point can introduce 'noise' in the image; lower settings can improve a noisy signal. This command does not take effect unless the 'minimum change required' in the (DTT) control is reached.	
SUBCODE INxy	DESCRIPTION OF USE Set the detail for Slot x, Input y.
MAIN	Set the detail for Main video.
PIIP	Set the detail for PIP video.

**(DTL) DETAIL**

EXAMPLE:  
 (DTL 50) - Set the detail to mid point for Main video.

**(DTO) DETAIL OVERTHOOT**

CONTROL GROUP: Input    SUBCLASS: Power Down    ACCESS LEVEL: Operator

DESCRIPTION  
 Detail overshoot / undershoot control is provided to minimize ringing on the enhanced edges detail and texture effects.

SUBCODE	DESCRIPTION OF USE
IN <sub>xy</sub>	Set the detail overshoot for Slot x, Input y.
MAIN	Set the detail overshoot for Main video.
PIIP	Set the detail overshoot for PIP video.

EXAMPLE:  
 (DTO 50) - Set the detail overshoot to mid point for Main video.

**(DTT) DETAIL THRESHOLD**

CONTROL GROUP: Input    SUBCLASS: Power Down    ACCESS LEVEL: Operator

DESCRIPTION  
 Detail threshold selects a filter sensitivity to noise. A higher value may improve noisy sources especially for higher settings of detail.  
 This control sets the minimum change required before the detail (DTL) function is activated. This allows images to be sharpened without increasing the background noise.

SUBCODE	DESCRIPTION OF USE
IN <sub>xy</sub>	Set the detail threshold for Slot x, Input y.
MAIN	Set the detail threshold for Main video.
PIIP	Set the detail threshold for PIP video.

EXAMPLE:  
 (DTT 50) - Set the detail threshold to mid point for Main video.

**(EBB) BLACK LEVEL BLENDING**

CONTROL GROUP: Config/Preference    SUBCLASS: Power Up    ACCESS LEVEL: Operator

DESCRIPTION  
 The Black Level Blending control allows for Black Level Blending. Black Level Blending is the process of modifying the pixels in the bright overlapping areas that result from the overlapping of two or more images. Correct adjustment eliminates uneven black levels by matching up black area hues with a target area hue (the intersection of the center lines), and adjusting the overlaps (edges) surrounding the target area. Use the black test pattern to perform this function.

<b>(EBB) BLACK LEVEL BLENDING (CONTINUED)</b>	
SUBCODE	DESCRIPTION OF USE
SLCT	Enables or disables Black Level Blending mode, or choose a saved Christie TWIST™ Black Level Blending preset.
CNTV	Changes edge blending black level in the center zone.
TOPV	Changes edge blending black level in the top zone.
LFTV	Changes edge blending black level in the left zone.
RHTV	Changes edge blending black level in the right zone.
BTMV	Changes edge blending black level in the bottom zone.
TLTV	Changes edge blending black level in the top-left zone.
TRTV	Changes edge blending black level in the top-right zone.
BLTV	Changes edge blending black level in the bottom-left zone.
BRTV	Changes edge blending black level in the bottom-right zone.
LFTW	Changes edge blending black level width of the left zone.
RHTW	Changes edge blending black level width of the right zone.
TOPW	Changes edge blending black level width of the top zone.
BTMW	Changes edge blending black level width of the bottom zone.
EXAMPLE: (EBB+CNTV 100) - Set black level blend offset of center zone to 100. (EBB+LFTW 200) - Set black level blend width of left zone to 200. (EBB+RHTW?) - Get black level blend width of right zone.	

<b>(EBL) EDGE BLENDING</b>	
CONTROL GROUP: Config/Preference    SUBCLASS: Power Up    ACCESS LEVEL: Operator	
DESCRIPTION This control the edge blending settings so that any of the four edges can be blended with an adjacent projector to achieve an overlapped and seamless image.	
SUBCODE	DESCRIPTION OF USE
SLCT	Enables or Disables standard edge blending mode, or choose a saved TWIST blending preset.
LFTW	Changes edge blending width of the left edge.
LFTM	Changes edge blending curve midpoint of the left edge.
LFTS	Changes edge blending curve slope at the midpoint on the left edge.
RHTW	Changes edge blending width of the right edge.
RHTM	Changes edge blending curve midpoint of the right edge.

<b>(EBL) EDGE BLENDING (CONTINUED)</b>	
RHTS	Changes edge blending curve slope at the midpoint on the right edge.
TOPW	Changes edge blending width of the top edge.
TOPM	Changes edge blending curve midpoint of the top edge.
TOPS	Changes edge blending curve slope at the midpoint on the top edge.
BTMW	Changes edge blending width of the bottom edge.
BTMM	Changes edge blending curve midpoint of the bottom edge.
BTMS	Changes edge blending curve slope at the midpoint on the bottom edge.
STDC	Enable the advanced curve settings.
OVLP	Enables or Disables edge blending overlap control. This more will make the active portion of the Blend zone very obvious and is intended to make setup easier.
<p>EXAMPLES:                      (EBL+LFTW100) -Set edge blending left width.                      (EBL+LFTW?) - Get edge blending left width.                      (EBL+SLCT1) - Use standard edge blending mode.                      (EBL+OVLP1) - Enables edge blending overlap mode.</p>	

<b>(EME) ERROR MESSAGE ENABLE</b>	
CONTROL GROUP: Preference    SUBCLASS: Power Down    ACCESS LEVEL: Operator	
<p>DESCRIPTION</p> <p>This control enables the displaying of error messages, and determines to which interface the messages are sent. Error messages can be turned off or can be displayed on the screen, sent out the serial port, or both. This setting does not affect messages for invalid user entries, for which error messages are always displayed. Valid values are:</p> <p>0 = Off                      1 = Screen                      2 = Serial ports                      3 = All</p>	
SUBCODE <No Subcode >	DESCRIPTION OF USE
<p>EXAMPLES:                      (EME ?) - Get current Error Message Enable state.                      (EME 1) - Direct error messages to the screen.</p>	

<b>(ESM) EM STEALTH MODE</b>	
<b>CONTROL GROUP:</b> Preference <b>SUBCLASS:</b> Power Down <b>ACCESS LEVEL:</b> Operator	
<b>DESCRIPTION</b> Stealth mode extinguishes LEDs on the Electronics Module. Typically this is used in simulation environments where extraneous light would detract from the scenario (when the scene involves IR).	
<b>SUBCODE</b> <No Subcode >	<b>DESCRIPTION OF USE</b>
<b>EXAMPLES:</b> (ESM 1) - Enable EM stealth mode. (ESM ?) - Report the stealth mode value.	

<b>(FAD) FADE TIME</b>	
<b>CONTROL GROUP:</b> Preference <b>SUBCLASS:</b> Power Down <b>ACCESS LEVEL:</b> Operator	
<b>DESCRIPTION</b> Controls the amount of time it takes to fade between images on a source switch. It also fades in the PIP and OSD if possible.	
<b>SUBCODE</b> <No Subcode >	<b>DESCRIPTION OF USE</b> Time in hundredths of a second to allow the fade. Range 0 - 150 where 150 = 1.5 seconds, 1 = 10ms, 0 = off.
<b>EXAMPLE:</b> (FAD 100) - Fade for 1 second.	

<b>(FAS) FAN ASSIST SWITCH</b>	
<b>CONTROL GROUP:</b> Saved <b>SUBCLASS:</b> Power Down <b>ACCESS LEVEL:</b> Operator	
<b>DESCRIPTION</b> Enables or disables the ability for all fans to operate at maximum speed during a thermal over-temp condition.	
<b>SUBCODE</b> <No Subcode >	<b>DESCRIPTION OF USE</b>
<b>EXAMPLES:</b> (FAS 1) - Turn ON fan assist. (FAS 0) - Turn OFF fan assist.	

<b>(FIL) FILTER</b>	
<b>CONTROL GROUP:</b> Input <b>SUBCLASS:</b> Power Up <b>ACCESS LEVEL:</b> Operator	
<b>DESCRIPTION</b> Apply an internal Low Pass Filter to the current Input signal, before the A/D conversion in analog cards. This removes high frequency noise from Input signals. HDTV is typically used for 720p and 1080i video sources. The high bandwidth filter should be used for 1080p or higher frequency sources. Valid values are:	

<b>(FIL) FILTER</b>	
0 = OFF 1 = HDTV-High Bandwidth	2 = HDTV 3 = EDTV 4 = SDTV
SUBCODE INxy	DESCRIPTION OF USE Set the filter for Slot x, Input y.
MAIN	Set the filter for Main video.
PIIP	Set the filter for PIP video.
EXAMPLES: (FIL 2) - Set the filter for main video to HDTV. (FIL+MAIN 2) - Set the filter for main video to HDTV. (FIL+IN32 2) - Set the filter for Slot 3, Input 2 to HDTV.	

<b>(FLE) FRAME LOCK ENABLE</b>	
CONTROL GROUP: Preference    SUBCLASS: Power Up    ACCESS LEVEL: Operator	
DESCRIPTION This control enables or disables Frame Lock, which controls how the projector controls the output frame timing based on the Input signal. When set to Frame Lock, output image frames are locked to the Input if possible. When locked, the output is always locked to the primary Input, never the PIP image. Free Run sets the output to close to 60Hz for all sources. This control must be set to locked if a 3D-Stereo signal is used.	
SUBCODE <No Subcode >	DESCRIPTION OF USE Enables or Disables frame lock.
EXAMPLES: (FLE 0) - Free Run output. (FLE 1) - Enables frame lock. (FLE ?) - Get frame lock enabled status.	

<b>(FLW) SERIAL FLOW CONTROL</b>	
CONTROL GROUP: Preference    SUBCLASS: Power Down    ACCESS LEVEL: Advanced	
DESCRIPTION Set the flow control for a serial communications port.	
SUBCODE PRTA	DESCRIPTION OF USE Set the mode on port A (RS-232 IN).
PRTB	Set the mode on port B (RS-232 OUT).
PRTC	Set the mode on port C (RS-422).
EXAMPLES: (FLW+PRTA 0) - Set no flow control on port A. (FLW+PRTA 1) - Set flow control on port A to software. (FLW+PRTA?) - Get flow control (FLW+PRTA!001 "Software")	

<b>(FMD) FILM MODE DETECT</b>	
CONTROL GROUP: Input    SUBCLASS: Power Up    ACCESS LEVEL: Operator	
DESCRIPTION Enable or disable film motion detection. This is only available for interlaced or segmented frame sources. Valid values are: 0 = Disabled 1 = Auto 2 = PsF	
SUBCODE IN <sub>xy</sub>	DESCRIPTION OF USE Set the film mode detect for Slot x, Input y.
MAIN	Set the film mode detect for Main video.
PIIP	Set the film mode detect for PIP video.
EXAMPLE: (FMD 1) - Enable Auto Film mode detect for Main video.	

<b>(FRD) FRAME DELAY</b>	
CONTROL GROUP: Preference    SUBCLASS: Power Up    ACCESS LEVEL: Operator	
DESCRIPTION Delays the output signal timing relative to the Input signal timing by a fraction of a frame, and up to several frames. The minimum latency can vary based on the amount of scaling applied to the image. When using keystone or warping, an additional latency is required, depending on the amount of warp. The control is only available when the Input signal is frame locked. In free run mode, or in cases where the signal cannot be frame locked, the minimum latency defined by the scaling and keystone/warp is applied to the signal. The value used is a 1/1000th of a frame. For example, 1000 equals 1 frame.	
SUBCODE STAT?	DESCRIPTION OF USE Retrieve the actual minimum frame delay.
EXAMPLES: (FRD 1500) - Delay 1.5 frames. (FRD+STAT?) - Retrieve actual minimum frame delay	

<b>(FRF) FREE RUN FREQUENCY</b>	
CONTROL GROUP: Preference    SUBCLASS: Power Up    ACCESS LEVEL: Operator	
DESCRIPTION This controls sets the output video vertical frequency.	
SUBCODE <No Subcode >	DESCRIPTION OF USE Set the output vertical frequency, used when running in “Free Run” mode. See <a href="#">(FLE) Frame Lock Enable</a> .



<b>(FRF) FREE RUN FREQUENCY (CONTINUED)</b>	
EXAMPLES: (FRF 5000) - Set free run frequency to 50 Hz. (FRF ?) - Get free run frequency.	

<b>(FRZ) FREEZE IMAGE</b>	
CONTROL GROUP: Unsaved    SUBCLASS: Power Up    ACCESS LEVEL: Operator	
DESCRIPTION Freeze the display image. This allows a detailed examination of a single frame of an otherwise moving image. Switching channels/Inputs automatically switches the projector to unfrozen.	
SUBCODE	DESCRIPTION OF USE
MAIN	Freeze or un-freeze the main image (1=freeze, 0=unfreeze).
PIIP	Freeze or un-freeze the PIP image (1=freeze, 0=unfreeze).
EXAMPLE: (FRZ+MAIN 1) - Freeze the main image.	

<b>(GAM) GAMMA CORRECTION</b>	
CONTROL GROUP: Preference    SUBCLASS: Power Up    ACCESS LEVEL: Operator	
DESCRIPTION The Gamma Correction control is used to correct ambient conditions affecting the display. The Gamma control affects the shape of the curve determining what grey shades are displayed for a given amount of signal Input between minimum (black) and maximum (white). This is done by performing a linear transform from the user selected gamma channel setting. The normal point is 0, meaning the selected gamma table is used unaltered. If there is a lot of ambient light, the image can become washed out, making it difficult or impossible to see details in dark areas. Increasing the gamma correction setting can compensate for this by transforming the curve towards a gamma of 1.0. Decreasing the control shall transform the gamma towards a gamma of 3.0.	
SUBCODE	DESCRIPTION OF USE
<No Subcode >	Set the interpolated gamma level.
EXAMPLES: (GAM 100) - Set gamma to 1.0 curve. (GAM?) - Returns current gamma curve.	

<b>(GIA) ANALOG BNC GROUNDED INPUT SELECTION</b>	
CONTROL GROUP: Option    SUBCLASS: Power Up    ACCESS LEVEL: Operator	
DESCRIPTION Set the Input signal grounding method to single-ended or differential. Valid values are: 0 = Differential (default) 1 = Single-ended	

<b>(GIA) ANALOG BNC GROUNDED INPUT SELECTION (CONTINUED)</b>	
SUBCODE SLxy	DESCRIPTION OF USE Set the Input signal grounding method for the specified Slot and Input.
EXAMPLES: (GIA+SL31 1) - Set grounding on Slot 3, Input 1 to single-ended. (GIA+SL11 ?) - Returns the current grounding method of Slot 1, Input 1.	

<b>(GID) VIDEO DECODER GROUNDED INPUT SELECTION</b>	
CONTROL GROUP: Option    SUBCLASS: Power Up    ACCESS LEVEL: Operator	
DESCRIPTION Set the Input signal grounding method to single-ended or differential. Valid values are: 0 = Differential (default) 1 = Single-ended	
SUBCODE SLxy	DESCRIPTION OF USE Set the Input signal grounding method for the specified Slot and Input.
EXAMPLES: (GID+SL31 1) - Set grounding on Slot 3, Input 1 to single-ended. (GID+SL16 ?) - Returns the current grounding method of Slot 1, Input 6.	

<b>(GIO) GENERAL PURPOSE INPUT/OUTPUT</b>	
CONTROL GROUP: Config    SUBCLASS: Power Down    ACCESS LEVEL: Advanced	
DESCRIPTION Control or monitor the state of the General Purpose Inputs and Outputs. The strings have one character for each hardware connector pin, and from left to right, correspond to the pin numbers 2,3,4,6,7,8,9. (Pin 1 is 12V and Pin 5 is Ground - they cannot be read, set or configured). A low state (or value of 0) will be read on an Input pin if the circuit attached to the pin is open. A high state (or value of 1) will be read on an Input pin if the circuit attached to the pin is shorted to ground. This corresponds to a switch closing event.	
SUBCODE CNFG	DESCRIPTION OF USE Set the Direction for the individual pins to Inputs or outputs.
STAT	Get the state of all Inputs, or set the state of all outputs.
EXAMPLES: (GIO+STAT?) - Get status of all the Inputs. Returns (GIO+STAT!"0000000") - All Inputs are low. (GIO+STAT "1x01000") - Set status of the GPOs - 2 high, 3 no change, 4 Low, 6 High, 7 Low, 8 Low, 9 Low. (GIO+STAT "hxxlxxx" 500) - Set status of the GPOs - 2 Pulse high, 6 Pulse Low. Use interval of 500 ms for each. (GIO+CNFG "IIOOOIO") - Set pins 2, 3 and 8 to Input, 4, 6, 7 and 9 to Output.	

<b>(GMS) VDIC GROUPED-INPUTS MODE</b>	
CONTROL GROUP: Option    SUBCLASS: Power Up    ACCESS LEVEL: Operator	
<p>DESCRIPTION</p> <p>Allows users to select a mode to group the last 3 BNC connectors (Input 4/5/6) on a Video Decoder Input Card. valid options are:                      0 = 3 CVBS sources                      1 = 1 SVideo Source + 1 CVBS source                      2 = 1 YPrPb (Component) source</p>	
<p>SUBCODE</p> <p>SLx0</p>	<p>DESCRIPTION OF USE</p> <p>Set a grouping mode for the last 3 BNC connectors on Video Decoder card in the selected Slot.</p>
<p>EXAMPLES:</p> <p>(GMS+SL10 0) - Use 3 BNC connectors for CVBS source.                      (GMS+SL10 1) - Use 3 BNC connectors for 1 SVideo and 1 CVBS sources.                      (GMS+SL10 2) - Use 3 BNC connectors for 1 YPbPr(component) source.                      (GMS+SL10 ?) - Get the current mode setting.</p>	

<b>(GNB) GREEN BLACK LEVEL</b>	
CONTROL GROUP: Input    SUBCLASS: Power Up    ACCESS LEVEL: Operator	
<p>DESCRIPTION</p> <p>Green black level is used to compensate for relative variations in the black levels between Red, Green and Blue. This is available on all cards expect the Video decoder. The correct setting achieves maximum contrast without crushing white or black. When the drive and black level controls are set correctly for a signal, the Comprehensive Color Adjustment, including color temperature, will work as expected. The drive and black level controls should not be used to setup a specific color temperature as this will require separate color temperature adjustments to be made for each signal.</p>	
<p>SUBCODE</p> <p>INxy</p>	<p>DESCRIPTION OF USE</p> <p>Set the green black level on Slot x, Input y to the specified value in the range of -255 to 255.</p>
<p>MAIN</p>	<p>Set the green black level on the main video to the specified value in the range -255 to 255.</p>
<p>PIIP</p>	<p>Set the green black level on the PIP video to the specified value in the range of -255 to 255.</p>
<p>EXAMPLES:</p> <p>(GNB 128) - Set green black level to 128 on Main video.                      (GNB+MAIN 128) - Set green black level to 128 on Main video.                      (GNB+PIIP 100) - Set green black level to 100 on PIP video.                      (GNB+IN32 100) - Set green black level to 100 on Slot 3, Input 2.                      (GNB?) - Returns the current green black level value on Main video.                      (GNB+PIIP ?) - Returns the current green black level value on PIP video.                      (GNB+IN12 ?) - Returns the current green black level value on Slot 1, Input 2.</p>	

<b>(GND) GREEN DRIVE</b>	
CONTROL GROUP: Input    SUBCLASS: Power Up    ACCESS LEVEL: Operator	
<p>DESCRIPTION</p> <p>The green drive level is used to compensate for different amounts of attenuation between the Red, Green and Blue in the signal. Available on all cards except the Video decoder.</p> <p>The correct setting achieves maximum contrast without crushing white or black. When the drive and black level controls are set correctly for a signal, the Comprehensive Color Adjustment, including color temperature, will work as expected. The drive and black level controls should not be used to setup a specific color temperature as this will require separate color temperature adjustments to be made for each source.</p>	
SUBCODE	DESCRIPTION OF USE
INxy	Set the green drive on Slot x, Input y to the specified value in the range of -255 to 255.
MAIN	Set the green drive on the main video to the specified value in the range -255 to 255.
PIIP	Set the green drive on the PIP video to the specified value in the range of -255 to 255.
<p>EXAMPLES:</p> <p>(GND 128) - Set green drive to 128 on Main video.</p> <p>(GND+MAIN 128) - Set green drive to 128 on Main video.</p> <p>(GND+PIIP 100) - Set green drive to 100 on PIP video.</p> <p>(GND+IN32 100) - Set green drive to 100 on Slot 3, Input 2.</p> <p>(GND?) - Returns the current green drive value on Main video.</p> <p>(GND+PIIP?) - Returns the current green drive value on PIP video.</p> <p>(GND+IN12?) - Returns the current green drive value on Slot 1, Input 2.</p>	

<b>(GOG) GREEN ODD PIXEL GAIN</b>	
CONTROL GROUP: Option    SUBCLASS: Power Up    ACCESS LEVEL: Operator	
<p>DESCRIPTION</p> <p>Adds an offset to Input green gain settings on the analog Input card. It is used to compensate for differences between the A to D converter used to sample even pixels, and the one used for odd pixels. A value of 0 is the null position in which both A to D converters are set to exactly the same value.</p>	
SUBCODE	DESCRIPTION OF USE
SLx0	Set a green gain offset for the second A to D.
<p>EXAMPLE:</p> <p>(GOG+SL10 -10) - Set a green gain offset to -10 on Slot 1.</p>	

<b>(GOO) GREEN ODD PIXEL OFFSET</b>	
CONTROL GROUP: Option    SUBCLASS: Power Up    ACCESS LEVEL: Operator	
DESCRIPTION Adds an offset to Input green black level settings on the analog Input card. It is used to compensate for differences between the A to D converter used to sample even pixels, and the one used for odd pixels. A value of 0 is the null position in which both A to D converters are set to exactly the same value.	
SUBCODE SLx0	DESCRIPTION OF USE Set a green black level offset for the second A to D.
EXAMPLE: (GOO+SL10 -10) - Set a green black level offset to -10 on Slot 1.	

<b>(HDC) DHDC DUAL-LINK CONFIGURATION</b>	
CONTROL GROUP: Option    SUBCLASS: Power Down    ACCESS LEVEL: Operator	
DESCRIPTION Select whether to use the 2 Inputs as separate Inputs, or combined as a dual-link. Select 'Automatic' to let the card decide, based on the Input signal. If the card cannot determine this, it will assume 2 single links. Valid values are: 0 = Automatic 1 = 2 Single Links 2 = Dual Link	
SUBCODE SLx0	DESCRIPTION OF USE Set a single/dual-link mode for the DHDIC.
EXAMPLES: (HDC+SL10 0) - Use Automatic detection for DHDIC on Slot 1. (HDC+SL40 1) - Use 2 Single Links for DHDIC on Slot 4. (HDC+SL10 2) - Use Dual-link for DHDIC on Slot 1. (HDC+SL10 ?) - Get the current dual-link mode for DHDIC on Slot 1.	

<b>(HLP) SERIAL HELP</b>	
CONTROL GROUP: Unsaved    SUBCLASS: Power Down    ACCESS LEVEL: Operator	
DESCRIPTION Query a list of all available serial commands, with brief descriptions and current enabled states.	
SUBCODE <No Subcode >	DESCRIPTION OF USE Request entire command Help listing, or list for a single command.
EXAMPLES: (HLP?) - Retrieve entire command Help listing. (HLP? "BRT") - Retrieve all subcodes/descriptions/enables for BRT control.	

<b>(HLT) PROJECTOR HEALTH</b>	
CONTROL GROUP: Unsaved    SUBCLASS: Power Down    ACCESS LEVEL: Operator	
<p>DESCRIPTION</p> <p>Any system health errors are placed on the troubleshooting queue. The queue, which contains the problems and a suggested solution for each one, is read-only. All problems in the queue are read using their index number, which starts from 0.</p> <p>Problems are assigned priorities:</p> <p>1 = Critical - Will result in failure to operate or shutdown</p> <p>2 = High - Will result in significant loss of functionality but the projector may continue to run</p> <p>3 = Low - Will result in minor loss of functionality which will not seriously affect projector</p>	
SUBCODE	DESCRIPTION OF USE
LSOL	List solutions.
LALL	List one or all problems and solutions.
<p>EXAMPLES:</p> <p>(HLT?) - Returns all queued problems.</p> <p>(HLT? 3) - Returns problem index 3 in the queue.</p> <p>(HLT+LSOL? 4) - Returns the solution hint for problem index 4 in the queue.</p> <p>(HLT+LALL?) - Returns all queued problems and their solutions.</p> <p>(HLT+LALL? 3) - Returns problem index 3 and its' solution.</p>	

<b>(HOR) HORIZONTAL POSITION</b>	
CONTROL GROUP: Input    SUBCLASS: Power Down    ACCESS LEVEL: Operator	
<p>DESCRIPTION</p> <p>Move the horizontal position of the image left or right.</p>	
SUBCODE	DESCRIPTION OF USE
MAIN	Set the horizontal position for the main image.
<p>EXAMPLES:</p> <p>(HOR 500) - Set horizontal position to 500 on main video.</p> <p>(HOR+MAIN 500) - Set horizontal position to 500 on main video.</p> <p>(HOR+IN32 500) - Set horizontal position to 500 on Slot 3, Input 2.</p> <p>(HOR?) - Returns the horizontal position value on main video.</p>	

<b>(INM) CHANNEL 'IN MENU'</b>	
CONTROL GROUP: Channel    SUBCLASS: Power Up    ACCESS LEVEL: Operator	
<p>DESCRIPTION</p> <p>Determine whether the channel should be visible in the Channel List, which is available by pressing the 'Channel' key on the remote's keypad.</p>	

<b>(INM) CHANNEL 'IN MENU' (CONTINUED)</b>	
SUBCODE C0xx	DESCRIPTION OF USE Toggle In Menu for channel (xx=channel number from 01 to 99).
MAIN	Toggle In Menu for the channel being used by main.
PIIP	Toggle In Menu for the channel being used by PIP.
EXAMPLES: (INM?) - Get channel in-menu state for channel used by main. (INM+MAIN?) - Get channel in-menu state for channel used by main. (INM+PIIP?) - Get channel in-menu state for channel used by PIP. (INM 1) - Show in-menu for the channel being used by main. (INM+PIIP 1) - Show in-menu for the channel being used by PIP. (INM+MAIN 0) - Hide in-menu for the channel being used by main. (INM+C001 0) - Hide in-menu for channel 1.	

<b>(ITG) TEST PATTERN GREY</b>	
CONTROL GROUP: Unsaved    SUBCLASS: Power Up    ACCESS LEVEL: Operator	
DESCRIPTION Specify the grey level to use for the 'Grey' flat field internal test pattern. Range 0-1023. The level defaults to 512 on power up. This command is on available while the grey test pattern is being displayed.	
SUBCODE <No Subcode >	DESCRIPTION OF USE
EXAMPLE: (ITG 512) - Set test pattern grey to mid point.	

<b>(ITP) INTERNAL TEST PATTERN</b>													
CONTROL GROUP: Unsaved    SUBCLASS: Power Up    ACCESS LEVEL: Operator													
DESCRIPTION Puts a test pattern on the screen or queries the test pattern currently displayed. Select which test pattern to display from the list:													
<table style="width: 100%; border: none;"> <tr> <td style="width: 33%;">0 = Off</td> <td style="width: 33%;">4 = Flat Grey</td> <td style="width: 33%;">8 = Color Bars</td> </tr> <tr> <td>1 = Grid</td> <td>5 = Black</td> <td>11 = Aspect Ratio</td> </tr> <tr> <td>2 = Grey Scale 16</td> <td>6 = Checker</td> <td>12 = Edge Blend</td> </tr> <tr> <td>3 = White</td> <td>7 = 13 Point</td> <td>14 = Boresight</td> </tr> </table>		0 = Off	4 = Flat Grey	8 = Color Bars	1 = Grid	5 = Black	11 = Aspect Ratio	2 = Grey Scale 16	6 = Checker	12 = Edge Blend	3 = White	7 = 13 Point	14 = Boresight
0 = Off	4 = Flat Grey	8 = Color Bars											
1 = Grid	5 = Black	11 = Aspect Ratio											
2 = Grey Scale 16	6 = Checker	12 = Edge Blend											
3 = White	7 = 13 Point	14 = Boresight											
SUBCODE <No Subcode >	DESCRIPTION OF USE Enable, disable or change standard test patterns.												
EXAMPLE: (ITP 0) - Disable test patterns - revert to previous Input signal. (ITP 1) - Set test pattern to the grid pattern.													

<b>(KCO) KEYSTONE CURSOR OFFSET</b>	
CONTROL GROUP: Preference    SUBCLASS: Power Up    ACCESS LEVEL: Operator	
DESCRIPTION This control offsets the 2D Keystone cursors from the edge of the image to allow manipulation of keystone on an overshot display.	
SUBCODE KCOT	DESCRIPTION OF USE Adjusts top offset.
KCOB	Adjusts bottom offset.
KCOL	Adjusts left offset.
KCOR	Adjusts right offset.
EXAMPLES: (KCO+KCOT 25) - Offsets the cursor by 25 pixels from the top edge. (KCO+KCOB?) - Returns the offset value in pixels from the bottom edge.	

<b>(KEN) KEYPAD IR SENSOR DISABLE</b>	
CONTROL GROUP: Preference    SUBCLASS: Power Down    ACCESS LEVEL: Operator	
DESCRIPTION Enable or disable the IR or wired keypad sensors. You cannot disable the keypad that is currently being used.	
SUBCODE FRNT	DESCRIPTION OF USE Set to 1 to enable the front IR keypad sensor, 0 to disable.
WIRE	Set to 1 to enable the wired keypad jack, 0 to disable.
EXAMPLES: (KEN+FRNT 0) - Disable front IR sensor. (KEN+WIRE?) - Get current wired jack enabled state.	

<b>(KEY) KEY CODE EMULATION</b>	
CONTROL GROUP: Unsaved    SUBCLASS: Power Down    ACCESS LEVEL: Operator	
DESCRIPTION Use Key Codes to emulate button presses on the IR or wired keypads.	
SUBCODE <No Subcode >	DESCRIPTION OF USE
EXAMPLES: (KEY 46) - Send the Power key (Down/press). (KEY 174) - Send the Power key (Up/release). (KEY?) - View the last emulated key that was sent.	



<b>(LBL) LEFT BLANKING</b>	
CONTROL GROUP: Input    SUBCLASS: Power Down    ACCESS LEVEL: Operator	
<p>DESCRIPTION</p> <p>Set the number of lines to blank (turn to black) at the left of the image. This can be used to blank out any unwanted data near the left edge of the image.</p> <p>A positive amount of blanking makes the image smaller. A negative amount of blanking makes the image larger. Negative blanking is only applicable to analog signals, when the auto setup has not been able to set the image size correctly. It is preferable not to use negative blanking, but to run auto setup again, ensuring that the content has active pixels on each edge of the image.</p> <p>The maximum amount of left blanking allowed is half the image width minus 10. For negative blanking, the image size can only be increased to the limit of the sync.</p>	
SUBCODE IN <sub>xy</sub>	DESCRIPTION OF USE Set the left blanking for Slot x, Input y.
MAIN	Set the left blanking for the Main image.
PIIP	Set the left blanking for the PIP image.
<p>EXAMPLES:</p> <p>(LBL 40) - Set left blanking to 40 on Main video.                      (LBL+MAIN 40) - Set left blanking to 40 on main video.                      (LBL+PIIP 40) - Set left blanking to 40 on PIP video.                      (LBL+IN32 40) - Set left blanking to 40 on Slot 3, Input 2.                      (LBL?) - Returns the left blanking value on main video.                      (LBL+PIIP?) - Returns the left blanking value on PIP video.                      (LBL+IN12?) - Returns the left blanking value on Slot 1, Input 2.</p>	

<b>(LDT) LEVEL DETECTOR</b>	
CONTROL GROUP: Unsaved    SUBCLASS: Power Up    ACCESS LEVEL: Operator	
<p>DESCRIPTION</p> <p>This Level Detector control changes the gamma table settings to make it easy for the user to adjust the Input levels. It causes the data to be processed so that all levels below a specified value are set to black (0) and all above and including it are set to white (1024). This control takes place before the scaler/deinterlacer.</p>	
SUBCODE <No Subcode >	DESCRIPTION OF USE
<p>EXAMPLES:</p> <p>(LDT 1) - Turn on level detector.                      (LDT 0) - Turn off level detector.</p>	

<b>(LDV) LEVEL DETECTOR VALUE</b>	
CONTROL GROUP: Unsaved    SUBCLASS: Power Up    ACCESS LEVEL: Operator	
DESCRIPTION The Level Value control specifies the value to be used by the level detector. The range is 1-1023. This control takes place before the scaler/deinterlacer.	
SUBCODE <No Subcode >	DESCRIPTION OF USE
EXAMPLE: (LDV 500) - Set level detector to 500. All data greater than or equal to 500 will be shown in the image.	

<b>(LOC) LOCAL SETTINGS</b>	
CONTROL GROUP: Preference    SUBCLASS: Power Down    ACCESS LEVEL: Advanced	
DESCRIPTION Set the localization options such as language and display options for temperature units.	
SUBCODE LANG	DESCRIPTION OF USE Set the system language: 0 - English                      4 - Italian 1 - French                        5 - Chinese 2 - German                       6 - Japanese 3 - Spanish                       7 - Korean
TEMP	Set the temperature units: 0 - Celsius 1 - Fahrenheit
EXAMPLES: (LOC+LANG 1) - Set language to French. (LOC+LANG ?) - Get language. (LOC+TEMP 1) - Set temperature to Fahrenheit.	

<b>(LSH) LOGICAL SHUTTER</b>	
CONTROL GROUP: Unsaved    SUBCLASS: Power Up    ACCESS LEVEL: Operator	
DESCRIPTION Turns OFF the LEDs in the projector to simulate a shutter operation. Additionally a white shutter mode is available which allows users to correct a setting which renders the display unusable: for example when no visible light is shown in IR modes.	
SUBCODE <No Subcode >	DESCRIPTION OF USE 0 Normal projection mode 1 Black (turns OFF light) 2 White (correction display)

**(LSH) LOGICAL SHUTTER (CONTINUED)**

EXAMPLES:  
 (LSH 1) - Turn OFF the LEDs.  
 (LSH ?) - Report current logical shutter setting.

**(MCS) MENU CASCADING ENABLE**

CONTROL GROUP: Preference    SUBCLASS: Power Down    ACCESS LEVEL: Operator

DESCRIPTION  
 Enable or disable cascading menus. When disabled, a single menu level will be displayed at a time.

SUBCODE	DESCRIPTION OF USE
<No Subcode >	Enable or disable cascading.

EXAMPLES:  
 (MCS ?) - Get the current state of this setting.  
 (MCS 0) - Disable cascading menus.  
 (MCS 1) - Enable cascading menus.

**(MDE) SERIAL MODE**

CONTROL GROUP: Preference    SUBCLASS: Power Down    ACCESS LEVEL: Advanced

DESCRIPTION  
 Set the mode for a serial communications port. Settings such as bits, parity and stop bits are grouped together into one selection.

SUBCODE	DESCRIPTION OF USE
PRTA	Set the mode on port A (RS-232 In).
PRTB	Set the mode on port B (RS-232 Out).
PRTC	Set the mode on port C (RS-422).

EXAMPLES:  
 (MDE+PRTA "8N1") - Set mode on port A to 8-bit, no parity, 1 stop bit.  
 (MDE+PRTA "7E1") - Set mode on port A to 7-bit, even parity, 1 stop bit.  
 (MDE+PRTA "7O1") - Set mode on port A to 7-bit, odd parity, 1 stop bit.  
 (MDE+PRTA?) - Get mode (MDE+PRTA!"8N1").

**(MFT) MENU FONT**

CONTROL GROUP: Preference    SUBCLASS: Power Down    ACCESS LEVEL: Operator

DESCRIPTION  
 Set the font size used by OSD.

SUBCODE	DESCRIPTION OF USE
<No Subcode >	View/Set Choose large font or small font as the font used by OSD.

<b>(MFT) MENU FONT (CONTINUED)</b>	
EXAMPLES: (MFT ?) - Get current font option used by the OSD. 0 is small font, 1 is large font. (MFT 1) - Use large font as the OSD font.	

<b>(MLK) CHANNEL MEMORY LOCK</b>	
CONTROL GROUP: Channel    SUBCLASS: Power Up    ACCESS LEVEL: Operator	
DESCRIPTION Lock a channel from being edited.	
SUBCODE C0xx	DESCRIPTION OF USE Lock channel (xx=channel number from 01 to 99).
MAIN	Lock the channel being used by main.
PIIP	Lock the channel being used by PIP.
EXAMPLES: (MLK?) - get channel locked state for channel used by main. (MLK+MAIN?) - Get channel locked state for channel used by main. (MLK+PIIP?) - Get channel locked state for channel used by PIP. (MLK 1) - Lock the channel being used by main. (MLK+PIIP 1) - Lock the channel being used by PIP. (MLK+MAIN 0) - Unlock the channel being used by main. (MLK+C001 0) - Unlock channel 1.	

<b>(MNR) MOSQUITO NOISE REDUCTION</b>	
CONTROL GROUP: Input    SUBCLASS: Power Down    ACCESS LEVEL: Operator	
DESCRIPTION Mosquito Noise Reduction (MNR) dynamically adapts to image content, effectively reducing mosquito artifacts around sharp edges in DCT based compression.	
SUBCODE INxy	DESCRIPTION OF USE Set the mosquito noise reduction for Slot x, Input y.
MAIN	Set the mosquito noise reduction for main video.
PIIP	Set the mosquito noise reduction for PIP video.
EXAMPLE: (MNR 32) - Set the mosquito noise reduction to mid point for main video.	

<b>(MNU) MENU SETTINGS AND CONFIGURATION</b>	
CONTROL GROUP: Preference    SUBCLASS: Power Down    ACCESS LEVEL: Operator	
DESCRIPTION Set menu type, view OSD state, read menu structure.	

**(MNU) MENU SETTINGS AND CONFIGURATION (CONTINUED)**

SUBCODE <No Subcode >	DESCRIPTION OF USE View/change the current state of the OSD (0=presentation, 1=main, 2=submenu).
EXAMPLE: (MNU?)(MNU!0)	

**(MSH) MENU SHIFT HORIZONTAL**

CONTROL GROUP: Preference    SUBCLASS: Power Up    ACCESS LEVEL: Operator	
DESCRIPTION Change the horizontal position of the main menu. If the position is not from one of the preset positions, MSP will be changed to Custom.	
SUBCODE <No Subcode >	DESCRIPTION OF USE View/set the horizontal position of the main menu.
EXAMPLES: (MSH ?) - Get current horizontal position of main menu. (MSH 50) - Set main menu horizontal position to 50 pixels from left edge.	

**(MSP) MENU LOCATION**

CONTROL GROUP: Preference    SUBCLASS: Power Up    ACCESS LEVEL: Operator	
DESCRIPTION Set the default menu position on the screen. Valid options are: 0 = 4:3 TopLeft 1 = 4:3 Inset 1 2 = 4:3 Inset 2 3 = 16:9 TopLeft 4 = 16:9 Inset 1 5 = 16:9 Inset 2 6 = Center	
SUBCODE <No Subcode >	DESCRIPTION OF USE View/set the preset menu position.
EXAMPLES: (MSP ?) Get current menu position preset. (MSP 0) Set main menu position to 4:3 TopLeft, the top left corner of screen. (MSP 6) Set menu position to the center of the screen.	

<b>(NAM) CHANNEL NAME</b>	
CONTROL GROUP: Channel    SUBCLASS: Power Up    ACCESS LEVEL: Operator	
DESCRIPTION Channel Name is optional text assigned to a channel and can appear in the Channel Setup menu, Channel Edit menu, the channel list and the Status menu.	
SUBCODE C0xx	DESCRIPTION OF USE Set the channel name for the channel (xx=channel number from 01 to 99).
MAIN	Set the channel name for the channel being used by main.
PIIP	Set the channel name for the channel being used by PIP.
EXAMPLES: (NAM?) - Get current active channel name for main video. (NAM+MAIN?) - Get channel name being used by main. (NAM+PIIP?) - Get channel name being used by PIP. (NAM "Test") - Set channel name being used by main to 'Test'. (NAM+PIIP "Test") - Set channel name being used by PIP to 'Test'. (NAM+MAIN "Test") - Set channel name being used by main to 'Test'. (NAM+C001 "Test") - Set channel name for channel 1 to 'Test.'	

<b>(NET) NETWORK SETUP</b>	
CONTROL GROUP: Config/Preference    SUBCLASS: Power Down    ACCESS LEVEL: Admin	
DESCRIPTION Set or request the network setup for this device.	
SUBCODE DOMA	DESCRIPTION OF USE Set the domain name
ETH0	Set the IP address for the first ethernet controller.
GATE	Set the network gateway.
HOST	Set the host name.
MAC0	Gets the MAC address of the first ethernet controller.
PORT	Set the PORT number.
SUB0	Set the network subnet mask for the first ethernet controller.

**(NET) NETWORK SETUP (CONTINUED)**

EXAMPLES:

- (NET+ETH0 "192.168.1.35") - Set new IP address on the first ethernet controller.
- (NET+GATE "192.168.0.1") - Set the gateway.
- (NET+SUB0 "255.255.255.0") - Set the subnet mask on the first ethernet controller.
- (NET+HOST "MyHostName") - Set the host name.
- (NET+DOMA "MyDomainName") - Set the domain name.
- (NET+ETH0 ?) - Get IP address from first controller. (NET+ETH0! "192.168.1.35").
- (NET+ETH1 ?) - Get IP address from second controller. (NET+ETH1! "192.168.1.36").
- (NET+MAC0 ?) - Get MAC address from first controller. (NET+MAC0! "00:12:3F:7B:76:B4").
- (NET+GATE ?) - Get default gateway. (NET+GATE! "192.168.0.1").
- (NET+PORT 3002) - Set the Port number.
- (NET+PORT ?) - Get the Port number. (NET+PORT! 3002).

**(NRB) BLOCK ARTIFACT REDUCTION**

CONTROL GROUP: Input    SUBCLASS: Power Down    ACCESS LEVEL: Operator

DESCRIPTION

Block Artifact Reduction (BAR) locates and reduces block edges produced by discrete cosine transform (DCT) based compression processing.

SUBCODE	DESCRIPTION OF USE
INxy	Set the BAR for Slot x, Input y.
MAIN	Set the BAR for main video.
PIIP	Set the BAR for PIP video.

EXAMPLE:

(NRB 32) - Set the BAR to mid point for main video.

**(NRD) GENERAL NOISE REDUCTION**

CONTROL GROUP: Input    SUBCLASS: Power Down    ACCESS LEVEL: Operator

DESCRIPTION

Adaptive general noise reduction selects a filter sensitivity to noise. A higher value may improve noisy sources, although it will soften the image.

SUBCODE	DESCRIPTION OF USE
INxy	Set the noise reduction for Slot x, Input y.
MAIN	Set the noise reduction for main video.
PIIP	Set the noise reduction for PIP video.

EXAMPLE:

(NRD 32) - Set the noise reduction to mid point for main video.

<b>(NTR) NETWORK ROUTING</b>	
CONTROL GROUP: Preference    SUBCLASS: Power Down    ACCESS LEVEL: Operator	
DESCRIPTION Set routing for ASCII messages.	
SUBCODE <No Subcode >	DESCRIPTION OF USE Used to enable or disable daisy chaining. 0 = RS-232, RS-422 & Ethernet communications are all separate from one another 1 = RS-422 port(s) is/are connected to the RS-232 network 2 = The Ethernet port is connected to the RS-232 network 3 = RS-232, RS-422 & Ethernet are all connected to each other
EXAMPLES: (NTR?L) - List routing options. (NTR 0) - Set routing so that each connection is routed separately. (NTR 3) - Set routing to full daisy-chaining.	

<b>(OPP) ODD PIXEL PHASE</b>	
CONTROL GROUP: Option    SUBCLASS: Power Up    ACCESS LEVEL: Operator	
DESCRIPTION Adds an offset to the pixel phase setting on this card. It is used to compensate for differences between the A to D converter used to sample even pixels, and the one used for odd pixels. A value of 0 is the null position in which both A and D converters are set to exactly the same value.	
SUBCODE SLx0	DESCRIPTION OF USE Set a pixel phase offset for the second A to D.
EXAMPLES: (OPP+SL10 -1) - Set a pixel phase offset to -1 on Slot 1.	

<b>(OSD) ON SCREEN DISPLAY</b>	
CONTROL GROUP: Unsaved    SUBCLASS: Power Down    ACCESS LEVEL: Operator	
DESCRIPTION Display or Hide the OSD screen.	
SUBCODE <No Subcode >	DESCRIPTION OF USE Turn ON/OFF OSD display.
EXAMPLES: (OSD ?) - Get current state of OSD. 0 when OSD is hidden, 1 when OSD is displayed. (OSD 0) - Turn OFF OSD display. The OSD will run in the background, even though it is not visible.	



<b>(OST) OSD TRANSPARENCY</b>	
CONTROL GROUP: Preference    SUBCLASS: Power Up    ACCESS LEVEL: Operator	
DESCRIPTION Enable or Disable on screen display transparency.	
SUBCODE <No Subcode >	DESCRIPTION OF USE Enable/Disable OSD transparency.
EXAMPLE: (OST 1) - Enable OSD transparency.	

<b>(PBC) PIP BORDER COLOR</b>																			
CONTROL GROUP: Preference    SUBCLASS: Power Up    ACCESS LEVEL: Operator																			
DESCRIPTION This control lets you choose the color of the optional border around the picture-in-picture (PIP) image. The border can be disabled by setting the border width PBW to zero. Valid options are:																			
<table style="width: 100%; border: none;"> <tr> <td style="width: 33%;">0 = Black</td> <td style="width: 33%;">5 = Dark Magenta</td> <td style="width: 33%;">10 = Green</td> </tr> <tr> <td>1 = Dark Red</td> <td>6 = Dark Yellow</td> <td>11 = Blue</td> </tr> <tr> <td>2 = Dark Green</td> <td>7 = Dark Grey</td> <td>12 = Cyan</td> </tr> <tr> <td>3 = Dark Blue</td> <td>8 = Light Grey</td> <td>13 = Magenta</td> </tr> <tr> <td>4 = Dark Cyan</td> <td>9 = Red</td> <td>14 = Yellow</td> </tr> <tr> <td></td> <td></td> <td>15 = White</td> </tr> </table>		0 = Black	5 = Dark Magenta	10 = Green	1 = Dark Red	6 = Dark Yellow	11 = Blue	2 = Dark Green	7 = Dark Grey	12 = Cyan	3 = Dark Blue	8 = Light Grey	13 = Magenta	4 = Dark Cyan	9 = Red	14 = Yellow			15 = White
0 = Black	5 = Dark Magenta	10 = Green																	
1 = Dark Red	6 = Dark Yellow	11 = Blue																	
2 = Dark Green	7 = Dark Grey	12 = Cyan																	
3 = Dark Blue	8 = Light Grey	13 = Magenta																	
4 = Dark Cyan	9 = Red	14 = Yellow																	
		15 = White																	
SUBCODE <No Subcode >	DESCRIPTION OF USE																		
EXAMPLE: (PBC 0) - Select black PIP border.																			

<b>(PBW) PIP BORDER WIDTH</b>	
CONTROL GROUP: Preference    SUBCLASS: Power Up    ACCESS LEVEL: Operator	
DESCRIPTION Selects whether a border should be placed around the PIP window. Setting the width to zero (0) will remove the border. Setting it to 1 will enable the border.	
SUBCODE <No Subcode >	DESCRIPTION OF USE
EXAMPLE: (PBW 10) - Select PIP border width of 10.	

<b>(PDT) PEAK DETECTOR</b>	
CONTROL GROUP: Unsaved    SUBCLASS: Power Up    ACCESS LEVEL: Operator	
<p>DESCRIPTION</p> <p>Enables or disables the peak detector test mode. This is used to aid in setup of Input levels. For each color, pixel values very near black will be displayed black, pixel values very near peak level will be displayed full on. All others will be displayed in mid-level grey. Input levels for each color should be adjusted so that black pixels in the image just turn black, and full on pixels just turn full ON. When adjustment is completed this control should be disabled to allow display of all grey levels. This control takes place before the scaler/deinterlacer.</p>	
SUBCODE <No Subcode >	DESCRIPTION OF USE
<p>EXAMPLES:</p> <p>(PDT 1) - Turn ON peak detector.                      (PDT 0) - Turn OFF peak detector.</p>	

<b>(PHP) PIP HORIZONTAL POSITION</b>	
CONTROL GROUP: Preference    SUBCLASS: Power Up    ACCESS LEVEL: Operator	
<p>DESCRIPTION</p> <p>Sets the horizontal position of the PIP window. Specifies where to place the center of the PIP window horizontally on the panel in pixels.</p>	
SUBCODE <No Subcode >	DESCRIPTION OF USE
<p>EXAMPLES:</p> <p>(PHP 100) - Set PIP horizontal position to 100 pixels.                      (PHP?) - Get PIP horizontal position. ((PHP!100), for example).</p>	

<b>(PHS) PIP HORIZONTAL SIZE</b>	
CONTROL GROUP: Preference    SUBCLASS: Power Up    ACCESS LEVEL: Operator	
<p>DESCRIPTION</p> <p>Sets the size (width) of the PIP window in pixels. The active portion of the Input signal, as determined by blanking controls, will be scaled to fit into the PIP window. The height of the PIP window will be set to maintain the aspect ratio of the image being captured, as determined by the vertical stretch control.</p>	
SUBCODE <No Subcode >	DESCRIPTION OF USE
<p>EXAMPLES:</p> <p>(PHS 100) - Set PIP size to 100 pixels.                      (PHS?) - Get PIP size ((PHS!100), for example).</p>	

(PIP) PICTURE IN PICTURE	
CONTROL GROUP: Preference    SUBCLASS: Power Up    ACCESS LEVEL: Operator	
DESCRIPTION This control enables or disables the picture-in-picture (PIP) mode. When this control is enabled for the first time, the first valid video signal starting at Slot 1, Input 1 is routed to the PIP window. If no signals are present, the first available Slot/Input combination is selected. PIP and image transition effects (seamless switching) both require resources to configure a second image processing path. Therefore these two features cannot be active at the same time.	
SUBCODE <No Subcode >	DESCRIPTION OF USE 0 = Disables PIP. 1 = Enables PIP.
EXAMPLES: (PIP 0) - Disables PIP video. (PIP 1) - Enables PIP video. (PIP ?) - Returns the state of the PIP control. i.e. (PIP! 1) - PIP enabled.	

(PJH) PROJECTOR HOURS	
CONTROL GROUP: Unsaved    SUBCLASS: Power Down    ACCESS LEVEL: Operator	
DESCRIPTION Reports the number of hours elapsed on the projector. This control is read-only.	
SUBCODE <No Subcode >	DESCRIPTION OF USE
EXAMPLE: (PJH ?) - Returns hours elapsed on projector.	

(PNG) PING	
CONTROL GROUP: Configuration    SUBCLASS: Power Down    ACCESS LEVEL: Status	
DESCRIPTION This command returns basic projector information to the user which includes the type of device & main software version. Note that some devices have multiple CPUs each with its own software version. Only the software version of what is considered to be the master CPU, is returned here. The return parameters are: Type, Major, Minor, Beta. The beta value is optional meaning it is an engineering build and has not been validated.	
<b>NOTE:</b> List of devices: 40 = ACT, 41 = Cinema, 42 = CinemaMini, 43 = Media Block, 44 = Mobius, 45 = Entero/StiM.	
SUBCODE <No Subcode >	DESCRIPTION OF USE
EXAMPLE: (PNG?) - (PNG!41 001 000 234) Indicates 'Cinema' type, software: 1 major, 0 minor, 234 beta.	

<b>(PPA) POSITION PRESET ASPECT</b>	
CONTROL GROUP: Preference    SUBCLASS: Power Down    ACCESS LEVEL: Operator	
<p>DESCRIPTION</p> <p>When enabled, this control ensures that during auto setup for any source, its aspect ratio is maintained when its default size is calculated. This is similar to cases where a stretch is defined for a source in the lookup table. If disabled and no stretch is defined, the source is scaled to fit the screen.</p>	
SUBCODE <No Subcode >	DESCRIPTION OF USE This command accepts either 0 or 1. 0 = disables maintain aspect, 1 = enables maintain aspect.
<p>EXAMPLES:</p> <p>(PPA 0) - Disables maintain aspect during auto setup. (PPA 1) - Enables maintain aspect during auto setup.</p>	

<b>(PPP) PIP POSITION PRESET</b>	
CONTROL GROUP: Preference    SUBCLASS: Power Up    ACCESS LEVEL: Operator	
<p>DESCRIPTION</p> <p>Choose a preset location and size for the PIP window. The Location settings will adjust the size and position of the window. Blanking will not be affected. While in split screen mode, several channel controls that resize image will be disabled. These controls are size, H-Position and V-Position. Valid values are:</p> <p>0 = Top Right 1 = Top Left 2 = Bottom Left 3 = Bottom Right</p>	
SUBCODE <No Subcode >	DESCRIPTION OF USE
<p>EXAMPLE:</p> <p>(PPP 0) - Select top right preset position.</p>	

<b>(PPS) PIP SWAP</b>	
CONTROL GROUP: Preference    SUBCLASS: Power Up    ACCESS LEVEL: Operator	
<p>DESCRIPTION</p> <p>This control swaps the current main and PIP Inputs. It will swap the Inputs regardless if there are valid signals on either of the Inputs.</p>	
SUBCODE <No Subcode >	DESCRIPTION OF USE
<p>EXAMPLE:</p> <p>(PPS) - Swap Inputs.</p>	

<b>(PRT) SERIAL PORT</b>	
CONTROL GROUP: Preference    SUBCLASS: Power Down    ACCESS LEVEL: Status	
DESCRIPTION Gets the current serial port being used, or gets a list of all serial ports available on the device.	
SUBCODE <No Subcode >	DESCRIPTION OF USE
EXAMPLES: (PRT ?) - Gets current serial port. (PRT ?L) - Gets list of ports.	

<b>(PTL) SERIAL PROTOCOL</b>	
CONTROL GROUP: Preference    SUBCLASS: Power Down    ACCESS LEVEL: Advanced	
DESCRIPTION Set the protocol for a serial communications port.	
SUBCODE PRTA	DESCRIPTION OF USE Set the protocol on port A (RS-232 In) pass through
PRTB	Set the protocol on port B (RS-232 Out).
PRTC	Set the protocol on port C (RS-422).
EXAMPLES: (PTL+PRTA "RAW") - Set protocol on port A to a pass through raw data protocol. (PTL+PRTA "CHRISTIE") - Set protocol on port A to a Christie Digital serial protocol. (PTL+PRTA?) - Get protocol (PTL+PRTA!"RAW").	

<b>(PVP) PIP VERTICAL POSITION</b>	
CONTROL GROUP: Preference    SUBCLASS: Power Down    ACCESS LEVEL: Operator	
DESCRIPTION Sets the vertical position of the PIP window. Specifies where to place the center of the PIP window vertically on the panel in pixels.	
SUBCODE <No Subcode >	DESCRIPTION OF USE
EXAMPLES: (PVP 100) - Set PIP vertical position to 100 pixels. (PVP?) - Get PIP vertical position (PVP!100).	

<b>(PWR) POWER</b>	
CONTROL GROUP: Unsaved    SUBCLASS: Power Down    ACCESS LEVEL: Operator	
<p>DESCRIPTION</p> <p>Change the power state of the projector.</p> <p><b>Possible values:</b></p> <p>0 - Power-OFF</p> <p>1 - Power-ON</p> <p>10 - Cooldown lamp is cooling down, controlled by lamp (Read-only)</p> <p>11 - Warmup lamp is warming up, controlled by lamp (Read-only)</p>	
SUBCODE	DESCRIPTION OF USE
<No Subcode >	Get or Set the power state of the projector.
<p>EXAMPLES:</p> <p>(PWR?) - get projector power status.</p> <p>(PWR1) - Turn the lamp and all electrical power ON.</p> <p>(PWR0) - Set the projector to standby mode.</p>	

<b>(PXP) PIXEL PHASE</b>	
CONTROL GROUP: Input    SUBCLASS: Power Down    ACCESS LEVEL: Operator	
<p>DESCRIPTION</p> <p>Pixel Phase adjusts the phase of the pixel sampling clock relative to the incoming signal. This allows you to fine tune the sampling point within one pixel. Adjust the Pixel Phase when the image (usually from an RGB source) shows shimmer. <b>NOTE:</b> If the shimmer is concentrated in vertical bands with little or no shimmer between the bands, then it is likely that Pixel Tracking needs adjustment. Pixel Tracking must be set correctly before adjusting Pixel Phase. Pixel Phase can only be set on Analog Input cards. The range is 0-31.</p>	
SUBCODE	DESCRIPTION OF USE
IN <sub>xy</sub>	Set the pixel phase for Slot x, Input y.
MAIN	Set the pixel phase for the main image.
PIIP	Set the pixel phase for the PIP image.
<p>EXAMPLES:</p> <p>(PXP 16) - Set pixel phase to 16 on main video.</p> <p>(PXP+MAIN 16) - Set pixel phase to 16 on main video.</p> <p>(PXP+PIIP 16) - Set pixel phase to 16 on PIP video.</p> <p>(PXP+IN32 16) - Set pixel phase to 16 on Slot 3, Input 2.</p> <p>(PXP?) - Returns the pixel phase value on main video.</p> <p>(PXP+PIIP?) - Returns the pixel phase value on PIP video.</p> <p>(PXP+IN12?) - Returns the pixel phase value on Slot 1, Input 2.</p>	

(PXT) PIXEL TRACKING	
CONTROL GROUP: Input    SUBCLASS: Power Down    ACCESS LEVEL: Operator	
<p>DESCRIPTION</p> <p>Pixel Tracking adjusts the position of the pixel sampling clock to match the Input signal. It can only be set on Analog Input cards. If adjusted incorrectly, flickering or vertical bars of noise appear across the image. Adjust Pixel Tracking so that the noise either disappears or fills the image. If it fills the image, use Pixel Phase to eliminate the noise. The range is 600-3000.</p>	
SUBCODE	DESCRIPTION OF USE
IN <sub>xy</sub>	Set the pixel tracking for Slot x, Input y.
MAIN	Set the pixel tracking for the main image.
PIIP	Set the pixel tracking for the PIP image.
<p>EXAMPLES:</p> <p>(PXT 600) - Set pixel tracking to 600 on main video.                      (PXT+MAIN 600) - Set pixel tracking to 600 on main video.                      (PXT+PIIP 600) - Set pixel tracking to 600 on PIP video.                      (PXT+IN32 600) - Set pixel tracking to 600 on Slot 3, Input 2.                      (PXT?) - Returns the pixel tracking value on main video.                      (PXT+PIIP?) - Returns the pixel tracking value on PIP video.                      (PXT+IN12?) - Returns the pixel tracking value on Slot 1, Input 2.</p>	

(RAL) REMOTE ACCESS LEVEL	
CONTROL GROUP: Preference    SUBCLASS: Power Down    ACCESS LEVEL: Admin	
<p>DESCRIPTION</p> <p>Set the remote serial protocol access level for a serial communications port.</p> <p><b>NOTE:</b> Valid selections are 0 - No Access, 1 - Login Required, 2 - Free Access                      Default value is 1 - Login required.</p>	
SUBCODE	DESCRIPTION OF USE
<No Subcode >	Set the access level on Ethernet all ports.
PRTA	Set the access level on port A (RS-232 In).
PRTB	Set the access level on port B (RS-232 Out).
PRTC	Set the access level on port C (RS-422).
<p>EXAMPLES:</p> <p>(RAL 0) - Disable remote serial protocol access level for all Ethernet ports.                      (RAL?) - Get access level for Ethernet ports (RAL!0).                      (RAL+PRTA 2) - Set remote serial protocol access level on port A (RS-232 In) to free access.                      (RAL+PRTA?) - Get access level (RAL+PRTA!2).</p>	

<b>(RBL) RIGHT BLANKING</b>	
CONTROL GROUP: Input    SUBCLASS: Power Down    ACCESS LEVEL: Operator	
<p>DESCRIPTION</p> <p>Set the number of lines to blank (turn to black) at the right of the image. This can be used to blank out any unwanted data near the right edge of the image.</p> <p>A positive amount of blanking makes the image smaller. A negative amount of blanking makes the image larger. Negative blanking is only applicable to analog signals, when the auto setup has not been able to set the image size correctly. It is preferable not to use negative blanking, but to run auto setup again, ensuring that the content has active pixels on each edge of the image.</p> <p>The maximum amount of right blanking allowed is half the image width minus 10. For negative blanking, the image size can only be increased to the limit of the sync.</p>	
SUBCODE	DESCRIPTION OF USE
INxy	Set the right blanking for Slot x, Input y.
MAIN	Set the right blanking for the main image.
PIIP	Set the right blanking for the PIP image.
<p>EXAMPLES:</p> <p>(RBL 40) - Set right blanking to 40 on main video.</p> <p>(RBL+MAIN 40) - Set right blanking to 40 on main video.</p> <p>(RBL+PIIP 40) - Set right blanking to 40 on PIP video.</p> <p>(RBL+IN32 40) - Set right blanking to 40 on Slot 3, Input 2.</p> <p>(RBL?) - Returns the right blanking value on main video.</p> <p>(RBL+PIIP?) - Returns the right blanking value on PIP video.</p> <p>(RBL+IN12?) - Returns the right blanking value on Slot 1, Input 2.</p>	

<b>(RDB) RED BLACK LEVEL</b>	
CONTROL GROUP: Input    SUBCLASS: Power Down    ACCESS LEVEL: Operator	
<p>DESCRIPTION</p> <p>Red black level is used to compensate for relative variations in the black levels between Red, Green and Blue. Available on all cards except the Video decoder.</p> <p>The correct setting is when the maximum contrast is achieved without crushing white or black. When the drive and black level controls are set correctly for a signal, the Comprehensive Color Adjustment, including color temperature, will work as expected. The drive and black level controls should not be used to setup a specific color temperature as this will require separate color temperature adjustments to be made for each signal.</p>	
SUBCODE	DESCRIPTION OF USE
INxy	Set the red black level on Slot x, Input y to the specified value in the range of -255 to 255.
MAIN	Set the red black level on the main video to the specified value in the range -255 to 255.
PIIP	Set the red black level on the PIP video to the specified value in the range of -255 to 255.



**(RDB) RED BLACK LEVEL (CONTINUED)**

EXAMPLES:

- (RDB 128) - Set red black level to 128 on main video.
- (RDB+MAIN 128) - Set red black level to 128 on main video.
- (RDB+PIIP 100) - Set red black level to 100 on PIP video.
- (RDB+IN32 100) - Set red black level to 100 on Slot 3, Input 2.
- (RDB?) - Returns the current red black level value on main video.
- (RDB+PIIP ?) - Returns the current red black level value on PIP video.
- (RDB+IN12 ?) - Returns the current red black level value on Slot 1, Input 2.

**(RDD) RED DRIVE**

CONTROL GROUP: Input    SUBCLASS: Power Down    ACCESS LEVEL: Operator

DESCRIPTION

The red drive level is used to compensate for different amounts of attenuation between the Red, Green and Blue in the signal. Available on all cards except the Video decoder.  
 The correct setting achieves maximum contrast without crushing white or black. When the drive and black level controls are set correctly for a signal, the Comprehensive Color Adjustment, including color temperature, will work as expected. The drive and black level controls should not be used to setup a specific color temperature as this will require separate color temperature adjustments to be made for each source.

SUBCODE	DESCRIPTION OF USE
IN <sub>xy</sub>	Set the red drive on Slot x, Input y to the specified value in the range of -255 to 255.
MAIN	Set the red drive on the main video to the specified value in the range -255 to 255.
PIIP	Set the red drive on the PIP video to the specified value in the range of -255 to 255.

EXAMPLES:

- (RDD 128) - Set red drive to 128 on main video.
- (RDD+MAIN 128) - Set red drive to 128 on main video.
- (RDD+PIIP 100) - Set red drive to 100 on PIP video.
- (RDD+IN32 100) - Set red drive to 100 on Slot 3, Input 2.
- (RDD?) - Returns the current red drive value on main video.
- (RDD+PIIP ?) - Returns the current red drive value on PIP video.
- (RDD+IN12 ?) - Returns the current red drive value on Slot 1, Input 2.

**(RGB) ADVANCED COLOR SETTING**

CONTROL GROUP: Preference    SUBCLASS: Power Up    ACCESS LEVEL: Operator

DESCRIPTION

Adjusts native projector color space by adjusting the LED power levels. This can significantly increase brightness of unsaturated colors. These adjustments turn on multiple RGB LEDs simultaneously which uses more power and increases the possibility of over-heating

<b>(RGB) ADVANCED COLOR SETTING (CONTINUED)</b>	
SUBCODE CLRM	DESCRIPTION OF USE Color Mode. Selects: 1 = Native                      4 = User preset 2 2 = EBU                          5 = User preset 3 3 = User preset 1              6 = User preset 4
ROFR	Red part of red (0-255)
GOFR	Green part of red (0-255)
BOFR	Blue part of red (0-255)
ROFG	Red part of green (0-255)
GOFG	Green part of green (0-255)
BOFG	Blue part of green (0-255)
ROFB	Red part of blue (0-255)
GOFB	Green part of blue (0-255)
BOFB	Blue part of blue (0-255)
RGBB	Controls overall brightness of LEDs (0-1000) percentage with one decimal place
COPY	Copies color mode settings from an existing preset to the current preset. Values: 1 = Copy from Native              4 = Copy from User 2 2 = Copy from EBU                5 = Copy from User 3 3 = Copy from User 1              6 = Copy from User 4
EXAMPLE: (RGB+ROFR 128) - Set Red of Red value. (RGB+BOFB ?) - Get Blue of Blue value. (RGB+RGBB 500) - Set overall brightness to 50%. (RGB+CLRM 4) - Select user preset 2. (RGB+COPY 2) - Copy EBU preset values to current preset	

<b>(ROG) RED ODD PIXEL GAIN</b>	
CONTROL GROUP: Option    SUBCLASS: Power Up    ACCESS LEVEL: Operator	
DESCRIPTION Adds an offset to Input red gain settings on the analog Input card. It is used to compensate for differences between the A to D converter used to sample even pixels, and the one used for odd pixels. A value of 0 is the null position in which both A to D converters are set to exactly the same value.	
SUBCODE SLx0	DESCRIPTION OF USE Set a red gain offset for the second A to D.

**(ROG) RED ODD PIXEL GAIN (CONTINUED)**

EXAMPLE:

(ROG+SL10 -10) - Set a red gain offset to -10 on Slot 1.

**(ROO) RED ODD PIXEL OFFSET**

CONTROL GROUP: Option SUBCLASS: Power Up ACCESS LEVEL: Operator

DESCRIPTION

Adds an offset to Input red black level settings on the analog Input card. It is used to compensate for differences between the A to D converter used to sample even pixels, and the one used for odd pixels. A value of 0 is the null position in which both A to D converters are set to exactly the same value.

SUBCODE

SLx0

DESCRIPTION OF USE

Set a red black level offset for the second A to D.

EXAMPLE:

(ROO+SL10 -10) - Set a red gain offset to -10 on Slot 1.

**(RQR) RGB QUANTIZATION RANGE**

CONTROL GROUP: Input SUBCLASS: Power Up ACCESS LEVEL: Operator

DESCRIPTION

Select RGB quantization range, 0 = full(0~255), 1 = limited(16~235).

SUBCODE

INxy

DESCRIPTION OF USE

Set the RGB quantization range for Slot x, Input y.

MAIN

Set the RGB quantization range for main video.

PIIP

Set the RGB quantization range for PIP video.

EXAMPLE:

(RQR 1) - Set RGB quantization range to limited.

**(RTE) REAL TIME EVENTS**

CONTROL GROUP: Unsaved SUBCLASS: Power Down ACCESS LEVEL: Operator

DESCRIPTION

Real time events allow custom user actions to occur based on a system trigger. There are various triggers in the system such as power up, channel change, errors, or based on time. Time can be absolute, (e.g. 12:00:00 on December 25, 2008) or relative (e.g. 5 hours and 30 minutes from now).

Special Function keys can also be used as a trigger. An example would be pressing FUNC+1 on the remote. Events can also be connected to external hardware triggers via the General Purpose IO port (GPIO).

**EVENTS:**
**Single Occurrence Events:**

(RTE T YYYY/MM/DD HH:MM:SS S "description" "command")

**(RTE) REAL TIME EVENTS (CONTINUED)**

**Daily Occurring Event:**

(RTE T YYYY/MM/DD HH:MM:SS YYYY/MM/DD D R "description" "command")

Where the first date and time is the start date and occurrence time. The second date is the end date.

R is the "Repeat Every" interval i.e. repeat every R days

**Weekly Occurring Event:**

(RTE T YYYY/MM/DD HH:MM:SS YYYY/MM/DD W R "D" "description" "command")

Where the first date and time is the start date and occurrence time. The second date is the end date.

R is the "Repeat Every" interval i.e. repeat every R weeks

D is the weekday or weekdays that the command should run on:

M = Monday                      W = Wednesday                      F = Friday                      Su = Sunday

Tu = Tuesday                      Th = Thursday                      S = Saturday

I.E. "MT" will run on Monday and Tuesday "TTh" will run on Tuesday and Thursday "MTWFSSu" will run on Monday, Tuesday, Wednesday, Friday, Saturday, and Sunday

**Monthly Occurring Event:**

(RTE T YYYY/MM/DD HH:MM:SS YYYY/MM/DD M R "description" "command")

Where the first date and time is the start date and occurrence time. The second date is the end date.

R is the "Repeat Every" interval i.e. repeat on the same date every R months

**NOTE:** If there are not 31 days in the next run cycle month, the event will not run in that month.

**Function Key Events:**

(RTE F K "description" "command"), where K = the specific function key (1-5,7-9). Key 6 is reserved and cannot be used.

**DMX Events:**

(RTE M C "description" "command"), where C = channel (54-63)

**System Events:**

(RTE S E T "description" "command"), where E is the event to respond to:

- |  |                                     |
|--|-------------------------------------|
| 0 = Boot Up                            | 2 = Any System Error                |
| 1 = Power ON/OFF                       | 3 = Good Signal                     |
| T = 0 (Either a Power ON or OFF event) | 4 = No Signal                       |
| T = 1 (Power ON only)                  | 5 = Input Change                    |
| T = 2 (Power OFF only)                 | 6 = Channel Change                  |
|  | T = channel (where channel is 1-99) |

**GPIO Events:**

(RTE G "AAAAAAA" "description" "command")

where A is GPIO Input for each pin:

- = X (don't care)
- = H (when pin is high) - See [\(GIO\) General Purpose Input/Output](#)
- = L (when pin is low) - See [\(GIO\) General Purpose Input/Output](#)

**(RTE) REAL TIME EVENTS (CONTINUED)**
**Delete All Events:**

(RTE X \*)

**Delete a single event:**

(RTE X A), where A is the event to be deleted (0-??)

SUBCODE

<No Subcode>

DESCRIPTION OF USE

EXAMPLE:

**Single Occurrence Events:**

(RTE T 2008/12/25 11:48:00 S "description" "(LSH 1)") - close the shutter at 11:48:00 on December 25, 2008

(RTE T 2009/01/01 23:00:00 S "description" "(CHA 2)") - switch to channel 2 on January 1, 2009 at 23:00:00

**Daily Occurring Event:**

(RTE T 2009/01/01 23:00:00 2009/02/01 D 1 "description" "(PWR 1)") - power on the projector every day at 23:00:00, starting from January 1, 2009 until February 1, 2009

(RTE T 2009/01/01 23:00:00 2009/02/01 D 2 "description" "(PWR 1)") - power on the projector every other day at 23:00:00, starting from January 1, 2009 until February 1, 2009

(RTE T 2009/01/01 23:00:00 2009/02/01 D 5 "description" "(PWR 1)") - power on the projector every fifth day at 23:00:00, starting from January 1, 2009 until February 1, 2009

**Weekly Occurring Event:**

(RTE T 2009/01/01 23:00:00 2009/03/01 W 1 "SSu" "description" "(PWR 0)") - power off the projector every week, on Saturday and Sunday at 23:00:00, starting from January 1, 2009 until March 1, 2009 (inclusive)

(RTE T 2009/01/01 23:00:00 2009/03/01 W 2 "MTWThF" "description" "(PWR 1)") - power on the projector every other week, on every weekday at 23:00:00, starting from January 1, 2009 until March 1, 2009 (inclusive)

(RTE T 2009/01/01 23:00:00 2009/03/01 W 5 "MTWThF" "description" "(PWR 1)") - power on the projector every fifth week, on every weekday at 23:00:00, starting from January 1, 2009 until March 1, 2009 (inclusive)

**Monthly Occurring Event:**

(RTE T 2009/01/1 23:00:00 2010/01/01 M 1 "description" "(PWR 0)") - power off the projector on the 1st day of every month at 23:00:00, starting January 1, 2009 until January 1, 2010 (inclusive)

(RTE T 2009/01/10 23:00:00 2010/01/01 M 12 "description" "(PWR 0)") - power off the projector on the 12th day of every 12 months at 23:00:00, starting January 12, 2009 until January 1, 2010 (inclusive)

(RTE T 2009/01/31 23:00:00 2010/01/01 M 2 "description" "(PWR 0)") - power off the projector every other month on day 31 starting January 31, 2009 until January 1, 2010 (inclusive)

**Function Key Events:**

(RTE F 1 "description" "(LSH 0)") - open the shutter if Func+1 is pressed on the remote

(RTE F 2 "description" "(LSH 1)") - close the shutter if Func+2 is pressed on the remote

<b>(RTE) REAL TIME EVENTS (CONTINUED)</b>
<p><b>DMX Events:</b></p> <p>(RTE M 55 "description" "(LSH 0)") - open the shutter when the DMX channel 55 is moved into the range of 192-255</p> <p>(RTE M 56 "description" "(LSH 1)") - close the shutter when the DMX channel 56 is moved into the range of 192-255</p> <p><b>System Events:</b></p> <p>(RTE S 1 1 "description" "(CLE 5)") - change color to cyan when system powers up</p> <p>(RTE S 3 "description" "(IRS 2)(DIM 2)") - change dynamic iris to "per channel" mode and turn on "dynamic" mode when we receive a good signal</p> <p>(RTE S 6 25 "description" "(LSH 1)") - close the shutter if channel 25 is selected</p> <p><b>GPIO Events:</b></p> <p>(RTE G "XXXXXXXX" "description" "(PWR 1)") - turn ON the projector if we receive any GPIO Input</p> <p>(RTE G "" "description" "(PWR 1)") - turn ON the projector if we receive any GPIO Input</p> <p>(RTE G "XX" "description" "(PWR 1)") - turn ON the projector if we receive any GPIO Input</p> <p>(RTE G "XXXXXLH" "description" "(PWR 0)") - turn OFF the projector if pin 6 is set to low and pin 7 is high</p> <p>(RTE G "HH" "description" "(FRZ 0)") - freeze the image if pins 1 and 2 are set to high</p> <p>(RTE G "XXHHXXH" "description" "(FRZ 0)") - freeze the image if pins 3,4,7 are set to high</p> <p>(RTE G "LLHXX" "description" "(FRZ 0)") - freeze the image if pins 1,2 are set to Low and pin 3 is set to high</p> <p>(RTE G "LLH" "description" "(FRZ 0)") - freeze the image if pins 1,2 are set to Low and pin 3 is set to high</p>

<b>(SIN) SELECT INPUT</b>	
CONTROL GROUP: Preference    SUBCLASS: Power Down    ACCESS LEVEL: Operator	
DESCRIPTION	
Select the active Input for the video in control (VIC). The VIC can be main or picture in picture (PIP). To specify a new Input routing, enter the number of the Slot followed by the Input. The projector will switch to that Input location and automatically select the channel best suited to the incoming signal. For example, 1 2 would indicate Slot 1 Input 2.	
SUBCODE	DESCRIPTION OF USE
MAIN	Set the active Input for the main video.
PIIP	Set the active Input for the (picture in picture) PIP video.
EXAMPLES:	
(SIN 12) - Set main video to Slot 1, Input 2.	
(SIN+MAIN 45) - Set main video to Slot 4, Input 5.	
(SIN+PIIP 21) - Set picture in picture video to Slot 2, Input 1.	
(SIN?) - Get the current main video Input (SIN!12) .	
(SIN+MAIN?) - Get the current main video Input (SIN+MAIN!12).	
(SIN+PIIP?) - Get the current (picture in picture) PIP video Input (SIN+PIIP!21).	

(SIZ) SIZE	
CONTROL GROUP: Input    SUBCLASS: Power Down    ACCESS LEVEL: Operator	
<p>DESCRIPTION</p> <p>This controls how much the projector will electronically expand or shrink the image. It will expand/contract the image in both the vertical and horizontal directions so that the aspect ratio will not change. 1000 is the neutral position where no resizing is done. Scale = value / 1000. The horizontal scaling of the image is always to exactly this value but the vertical scale is also controlled by the VST control which stretches the image vertically. When size is changed on PIP video, nothing will visually happen. It gets saved in the PIP's channel and will be applied the next time that channel is on main video.</p>	
SUBCODE <No Subcode >	DESCRIPTION OF USE Set the size for the main image.
<p>EXAMPLES:</p> <p>(SIZ 500) - Set size to 500 on main video.                      (SIZ?) - Returns the size value on main video.</p>	

(SMP) SAMPLING MODE	
CONTROL GROUP: Input    SUBCLASS: Power Up    ACCESS LEVEL: Operator	
<p>DESCRIPTION</p> <p>This control sets the color sampling mode for a digital signal to either YCbCr 4:4:4, RGB or YCbCr 4:2:2. Although the proper sampling mode is determined automatically by the projector, you can override the setting. Valid values are:                      0 = YCbCr 4:4:4 (or RGB)                      1 = YCbCr 4:2:2</p>	
SUBCODE IN <sub>xy</sub>	DESCRIPTION OF USE Set the sampling mode on Slot x, Input y.
MAIN	Set the sampling mode on main video.
PIIP	Set the sampling mode on PIP video.
<p>EXAMPLES:</p> <p>(SMP 1) - Set sampling mode to YCbCr422 on main video.                      (SMP+MAIN 0) - Set sampling mode to YCbCr444 on main video.                      (SMP+PIIP 1) - Set sampling mode to YCbCr422 on PIP video.                      (SMP+IN32 1) - Set sampling mode to YCbCr422 on Slot 3, Input 2.                      (SMP?) - Returns the current sampling mode value on main video.                      (SMP+PIIP?) - Returns the current sampling mode value on PIP video.                      (SMP+IN12?) - Returns the current sampling mode value on Slot 1, Input 2.</p>	

<b>(SOR) SCREEN ORIENTATION</b>	
CONTROL GROUP: Preference    SUBCLASS: Power Up    ACCESS LEVEL: Operator	
<p>DESCRIPTION</p> <p>Selects the orientation of the displayed image. It can be displayed normally, inverted horizontally, inverted vertically, or inverted in both directions, as required by the projector installation. Valid values are:</p> <p>0 = Front Projection            1 = Rear Projection            2 = Front Projection Inverted            3 = Rear Projection Inverted</p>	
SUBCODE	DESCRIPTION OF USE
<No Subcode >	
<p>EXAMPLE:</p> <p>(SOR 0) - Set image orientation to Front projection.</p>	

<b>(SPS) SPLASH SCREEN</b>	
CONTROL GROUP: Preference    SUBCLASS: Power Up    ACCESS LEVEL: Operator	
<p>DESCRIPTION</p> <p>Upload a User Splash Screen (logo) bitmap and configure splash screen display options.</p>	
SUBCODE	DESCRIPTION OF USE
<No Subcode >	<p>View/Set option indicating when a logo is displayed. Valid values are:</p> <p>0 = Always OFF            1 = Display on Startup only            2 = Display on Startup and when there is no Signal</p>
SLCT	<p>View/Set which logo to display. Valid values are:</p> <p>0 = Default Splash Screen            1 = User Splash Screen</p>
<p>EXAMPLES:</p> <p>(SPS ?) - Get the display option. If 0, logo is always OFF. 1, logo is displayed at start up, etc.            (SPS 2) - Set the display option. Logo will be displayed when there is no signal.            (SPS+SLCT 0) - Use Christie logo.</p>	



<b>(SPT) SPLIT SCREEN</b>	
CONTROL GROUP: Unsaved    SUBCLASS: Power Down    ACCESS LEVEL: Status	
<p>DESCRIPTION</p> <p>Split screen enable control. Allows a snap shot of the main image to be presented on the right side of the screen to allow evaluation of advanced image processing features. All resizing controls are honoured on both images. However, image processing controls only happen on the left side image. Changing Inputs, channels or test patterns will disable this control. PIP operation must be disabled prior to enabling this control.</p> <p>Valid options are:                      0 = OFF                      1 = Side                      2 = Top</p>	
SUBCODE <No Subcode >	DESCRIPTION OF USE
<p>EXAMPLES:</p> <p>(SPT 1) - Turn ON split screen to the side.                      (SPT 0) - Turn OFF split screen.</p>	

<b>(SST) SYSTEM STATUS</b>	
CONTROL GROUP: Preference    SUBCLASS: Power Down    ACCESS LEVEL: Status	
<p>DESCRIPTION</p> <p>Retrieve the various system status groups.</p>	
SUBCODE <No Subcode >	DESCRIPTION OF USE Returns information on all status groups, with one message per item.
ALRM	Returns a summary of any active alarms.
CONF	Returns configuration data - model, sn, build date, etc.
COOL	Returns cooling data - cooling fans, air flow, etc.
HLTH	Returns system health.
LAMP	Returns LAMP operational data.
SIGN	Returns signal data - freq, etc.
SYST	Returns system data - power, hours of use, shutter open, etc.
TEMP	Returns temperature data.
VERS	Returns version numbers.
<p>EXAMPLES:</p> <p>(SST+ALRM?) returns (SST+ALRM!000 002 "101" "Prism temperature")                      where parameters are P1=index number, P2=error level, P3=value, P4=description.                      Error level is 0=no errors or warnings, 1=warning, 2=error, 3=error and warning.</p>	

<b>(STD) VIDEO STANDARD</b>	
CONTROL GROUP: Input    SUBCLASS: Power Up    ACCESS LEVEL: Operator	
<p>DESCRIPTION</p> <p>This control displays or sets the current video standard that is decoding the Input signal. You can allow the projector to automatically determine the standard or you can specify a specific standard from the selection list.</p> <p>0 = Auto. Automatically determined by decoder.</p> <p>1 = PAL is a commonly used format in much of Europe, China, Australia, and some South American and African countries.</p> <p>2 = NTSC is a commonly used format in North America, and Japan.</p> <p>3 = SECAM is a format found primarily in France, Eastern Europe and much of Africa.</p> <p>4 = NTSC44 is a tape-only standard and is usually used with hybrid signals used to provide compatibility with video material of another TV format without a complete translation.</p> <p>5 = PAL-M is a format found primarily in Brazil.</p> <p>6 = PAL-NC is a format found primarily in Argentina and Chile, and some other Latin American countries.</p> <p>7 = PAL-60</p> <p>Only those standards that have similar horizontal and vertical frequencies to the current Input source are enabled.</p>	
SUBCODE	DESCRIPTION OF USE
INxy	Set the video standard on Slot Input y to the specified value in the range of known video standards.
MAIN	Set the video standard on the main video to the specified value in the range of known video standards.
PIIP	Set the video standard on the PIP video to the specified value in the range of known video standards.
<p>EXAMPLES:</p> <p>(STD 0) - Set video standard to 0 (PAL) on main video.</p> <p>(STD+MAIN 1) - Set video standard to 1(NTSC_M) on main video.</p> <p>(STD+PIIP 0) - Set video standard to 0(PAL) on PIP video.</p> <p>(STD+IN32 3) - Set video standard to 3(NTSC_4_43) on Slot 3 Input 2.</p> <p>(STD ?) - Returns the current video standard on main video.</p> <p>(STD+PIIP ?) - Returns the current video standard value on PIP video.</p> <p>(STD+IN12 ?) - Returns the current video standard value on Slot 1 Input 2.</p>	

<b>(SZP) SIZE PRESETS</b>	
CONTROL GROUP: Unsaved    SUBCLASS: Power Up    ACCESS LEVEL: Operator	
<p>DESCRIPTION</p> <p>Sets the image to one of several preset size/position presets.</p> <p>0 = Default                      3 = Full Width                      5 = Anamorphic</p> <p>1 = None                              4 = Full Height                      6 = Custom</p> <p>2 = Full Screen</p>	
SUBCODE	DESCRIPTION OF USE
<No Subcode >	

### (SZP) SIZE PRESETS (CONTINUED)

EXAMPLES:

(SZP 1) - Set the size preset to no resizing.

### (TBL) TOP BLANKING

CONTROL GROUP: Input    SUBCLASS: Power Down    ACCESS LEVEL: Operator

#### DESCRIPTION

Set the number of lines to blank (turn to black) at the top of the image. This can be used to blank out any unwanted data near the top edge of the image.

A positive amount of blanking makes the image smaller. A negative amount of blanking makes the image larger. Negative blanking is only applicable to analog signals, when the auto setup has not been able to set the image size correctly. It is preferable not to use negative blanking, but to run auto setup again, ensuring that the content has active pixels on each edge of the image.

The maximum amount of top blanking allowed is half the image height minus 10. For negative blanking, the image size can only be increased to the limit of the sync.

SUBCODE	DESCRIPTION OF USE
IN <sub>xy</sub>	Set the top blanking for Slot x, Input y.
MAIN	Set the top blanking for the main image.
PIIP	Set the top blanking for the PIP/secondary image.

EXAMPLES:

(TBL 40) - Set top blanking to 40 on main video.

(TBL+MAIN 40) - Set top blanking to 40 on main video.

(TBL+PIIP 40) - Set top blanking to 40 on PIP video.

(TBL+IN32 40) - Set top blanking to 40 on Slot 3 Input 2.

(TBL?) - Returns the top blanking value on main video.

(TBL+PIIP?) - Returns the top blanking value on PIP video.

(TBL+IN12?) - Returns the top blanking value on Slot 1 Input 2.

### (TCS) TARGET COLOR SPACE

CONTROL GROUP: Preference    SUBCLASS: Power Up    ACCESS LEVEL: Operator

#### DESCRIPTION

This command is used to set the ArrayLOC target gamut. Several preset color spaces are provided in addition to four user setting gamuts. The control subcodes provide access to all the presets. Due to the large number of subcodes they are not all listed. Instead a simple substitution for the small 'x' is made, according to the following table:

M	Max drives, read only
E	EBU, read only
S	SD Video, read only
H	HD Video, read only
F	Factory, read only

<b>(TCS) TARGET COLOR SPACE (CONTINUED)</b>	
1	User 1
2	User 2
3	User 3
4	User 4
C	Alias to selected table
<b>SUBCODE</b> SLCT	<b>DESCRIPTION OF USE</b> Selects the color space preset: 0 = Max drives (M)            4 = Factory (F) 1 = EBU (E)                    5 = User 1 (1) 2 = SD Video (S)            6 = User 2 (2) 3 = HD Video (H)            7 = User 3 (3) 8 = User 4 (4)
RDxX	Adjusts the x coordinate of the red color point (0 - 800 with 3 decimal places)
RDxY	Adjusts the y coordinate of the red color point (0 - 800 with 3 decimal places)
GNxX	Adjusts the x coordinate of the green color point (0 - 800 with 3 decimal places)
GNxY	Adjusts the y coordinate of the green color point (0 - 800 with 3 decimal places)
BLxX	Adjusts the x coordinate of the blue color point (0 - 800 with 3 decimal places)
BLxY	Adjusts the y coordinate of the blue color point (0 - 800 with 3 decimal places)
COPY	Copy gamut settings from preset to current. Value 0-8 for source preset
CCAP	Read-only field which returns string that gives relationship between projector capability and the color target.
<b>EXAMPLES:</b> (TCS+SLCT 1) - Select EBU color gamut as target (TCS+RDCX 290) - Set current Target gamut red x point to 0.290 (TCS+BLEY ?) - Return value of EBU preset blue y point (TCS+COPY 3) - Copy settings from HD Video to current	

(TED) TWIN HDMI EDID TYPE SELECTION	
CONTROL GROUP: Option    SUBCLASS: Power Up    ACCESS LEVEL: Operator	
DESCRIPTION Set the preferred EDID Timings on the Twin HDMI Input card. Available Models are: 0 = Default 1 = 3D 2 = Custom <b>NOTE:</b> 3D option (1) is not supported for Entero or Matrix StIM/SIM.	
SUBCODE SLxy	DESCRIPTION OF USE Set the EDID timings on Slot x to the specified type.
EXAMPLES: (TED+SL31 2) - Set EDID type to 2 (Custom) on Slot 3 Input 1. (TED+SL12?) - Returns the current EDID type on Slot 1 Input 2.	

(TIL) TILING CONTROL	
CONTROL GROUP: Preference    SUBCLASS: Power Up    ACCESS LEVEL: Operator	
DESCRIPTION Set the projector as part of a tiled array.	
SUBCODE SLCT	DESCRIPTION OF USE Enable or disable tiling.
RTOT	Set the total number of rows in the projector array.
CTOT	Set the total number of columns in the projector array.
RVAL	Set the row number of this projector.
CVAL	Set the column number of this projector.
EXAMPLES: (TIL+SLCT 1) - Enable tiling. (TIL+RTOT 2) - Set the total number of rows of projectors to 2. (TIL+CTOT 2) - Set the total number of columns of projectors to 2. (TIL+RVAL 2) - Set the projector to be in the 2nd row. (TIL+CVAL 1) - Set the projector to be in the 1st column.	

(TMD) TIME/DATE	
CONTROL GROUP: Preference    SUBCLASS: Power Down    ACCESS LEVEL: Admin	
DESCRIPTION Set the date, time or time zone.	
SUBCODE DATE	DESCRIPTION OF USE Set the date in the form yyyy/mm/dd.

<b>(TMD) TIME/DATE</b>	
TIME	Set the local time in the form hh:mm:ss <b>NOTE:</b> Time must be set using a 24-hour clock (regardless of LOC+TIME setting).
EXAMPLES: (TMD+TIME "17:50:45") - Set new local time. (TMD+DATE "2007/02/30") - Set the local date. (TMD+TIME?) - Get local time (TMD+TIME! 17:50:45).	

<b>(TNT) TINT</b>	
CONTROL GROUP: Input    SUBCLASS: Power Up    ACCESS LEVEL: Operator	
DESCRIPTION Tint adjusts the balance of red-to-green in your image. It is useful only for video images processed by decoder cards.	
SUBCODE IN <sub>xy</sub>	DESCRIPTION OF USE Set the tint level on Slot x, Input y to the specified value in the range of -45 deg to 45 deg.
MAIN	Set the tint level on the main video to the specified value in the range -45 deg to 45 deg.
PIIP	Set the tint level on the PIP video to the specified value in the range of -45 deg to 45 deg.
EXAMPLES: (TNT 40) - Set tint level to 40 on main video. (TNT+MAIN 40) - Set tint level to 40 on main video. (TNT+PIIP 20) - Set tint level to 20 on PIP video. (TNT+IN32 40) - Set tint level to 40 on Slot 3 Input 2. (TNT ?) - Returns the current tint level on main video. (TNT+PIIP ?) - Returns the current tint level on PIP video. (TNT+IN12 ?) - Returns the current tint level on Slot 1 Input 2.	

<b>(TPE) TEST PATTERN ENABLE</b>	
CONTROL GROUP: Preference    SUBCLASS: Power Up    ACCESS LEVEL: Operator	
DESCRIPTION Automatically select White test pattern based on the control being adjusted. Certain controls that deal with color settings will enable white test pattern when entering OSD menus and disable when exiting the menu. This control defines whether this happens. There are some situations where the user may not want to automatically go to a white test pattern when the OSD menu is selected, for example if they have specific content that they wish to evaluate.  0 = Disable automatic test pattern enable 1 = Enable automatic test pattern enable	

SUBCODE	DESCRIPTION OF USE
<No Subcode>	
<b>EXAMPLES:</b> (TPE 0) - Disable test pattern enable. (TPE ?) - Report state of test pattern enable.	

<b>(TTM) THIC TRANSMITTER MODE CONFIGURATION</b>	
CONTROL GROUP: Option    SUBCLASS: Power Down    ACCESS LEVEL: Operator	
<b>DESCRIPTION</b> Select a working mode for one of the transmitters on the THIC card. 0 = 'Default' to select 12-bit per channel HDMI output 1 = 'Compatible' to select 8-bit per channel HDMI output 2 = 'DVI only' to select 8-bit per channel DVI output	
SUBCODE	DESCRIPTION OF USE
SLxy	Set transmitter working mode for THIC card.
<b>EXAMPLES:</b> (TTM+SL11 0) - Use 12 bit HDMI output for THIC on Slot 1, Input 1. (TTM+SL42 1) - Use 8 bit HDMI output for THIC on Slot 4, Input 2. (TTM+SL11 2) - Use 8 bit DVI output for THIC on Slot 1, Input 1. (TTM+SL12 ?) - Get the transmitter working mode for THIC on Slot 1, Input 2.	

<b>(TWP) TARGET WHITE POINT</b>	
CONTROL GROUP: Preference    SUBCLASS: Power Up    ACCESS LEVEL: Operator	
<b>DESCRIPTION</b> This command is used to set the ArrayLOC target white-point. Several preset white points are provided in addition to four user setting white points. The control subcodes provide access to all the presets. Due to the large number of sub-codes they are not all listed. Instead a simple substitution for the small 'x' is made, according to the following table:	
0	3200K
1	5000K (D50)
2	6500K (D65)
3	7500K (D75)
4	9300K (D93)
5	User 1
6	User 2
7	User 3
8	User 4
C	Current





(UID) USER ID	
CONTROL GROUP: Unsaved    SUBCLASS: Power Down    ACCESS LEVEL: None	
DESCRIPTION Allows users to login to the serial interface.	
SUBCODE <No Subcode >	DESCRIPTION OF USE
EXAMPLES: (UID "username" "password") - Login a user. (UID) - Logout the current user, also happens automatically when a new user logs in. (UID?) - Display the current logged in user and their access level (UID!"username" 01).	

(VBL) VIDEO BLACK INPUT	
CONTROL GROUP: Input    SUBCLASS: Power Up    ACCESS LEVEL: Operator	
DESCRIPTION This control affects the black level for video signals. Most NTSC video standards include an offset to black which is useful for setting up CRT projectors. Set this control to 7.5 IRE if the video black level seems excessively elevated. Set to 0 IRE if video black levels are crushed. This control applies to analog cards with YUV color space only. Valid values are: 0 = 0 IRE 1 = 7.5 IRE	
SUBCODE IN <sub>xy</sub>	DESCRIPTION OF USE Get the video black level for Slot x, Input y.
MAIN	Set the video black level for main video.
PIIP	Set the video black level for PIP video.
EXAMPLES: (VBL 1) - Set the video black level for main video to 7.5 IRE. (VBL+MAIN 1) - Set the video black level for main video to 7.5 IRE. (VBL+IN32 0) - Set the video black level for PIP video to 0 IRE. (VBL?) - Returns the video black level on main video.	

(VRT) VERTICAL POSITION	
CONTROL GROUP: Input    SUBCLASS: Power Down    ACCESS LEVEL: Operator	
DESCRIPTION This control sets the vertical position of the image.	
SUBCODE <No Subcode >	DESCRIPTION OF USE Set the vertical position for the main image.
EXAMPLE: (VRT 500) - Set vertical position to 500 on main video. (VRT?) - Returns the vertical position value on main video.	

<b>(VST) VERTICAL STRETCH</b>	
CONTROL GROUP: Input    SUBCLASS: Power Down    ACCESS LEVEL: Operator	
<p>DESCRIPTION</p> <p>Use Vertical Stretch to adjust the height of the image while keeping the width constant. This controls how much the image is electronically stretched vertically. As it does not affect the horizontal width, it changes the aspect ratio of the image. 1000 is the neutral position where no stretching is done.</p> <p>Vertical Scale = (VST-Value / 1000) * (SIZ-Value / 1000).</p>	
SUBCODE <No Subcode >	DESCRIPTION OF USE Set the vertical stretch for the main image.
<p>EXAMPLES:</p> <p>(VST 500) - Set vertical stretch to 500 on main video.</p> <p>(VST?) - Returns the vertical stretch value on main video.</p>	

<b>(WRP) WARP / KEYSTONE</b>	
CONTROL GROUP: Configuration/Unsaved    SUBCLASS: Power Up    ACCESS LEVEL: Operator	
<p>DESCRIPTION</p> <p>This serial command will control the writing and reading of 2D keystone maps, warp maps, edge-blend map, uniformity maps and associated parameters.</p> <p><b>NOTE:</b> <i>The commands below are used from the OSD only, and are not highly applicable for use from Serial Commands. If they are set, they will only be applied on Power up or if applying them from the OSD.</i></p>	
SUBCODE SLCT	DESCRIPTION OF USE Select Warping mode: 0 = disabled 1 = 2D keystone 2 = TWIST maps
KRST	Reset keystone settings to zero
<p>EXAMPLES:</p> <p>(WRP+SLCT 0) - Warping disabled.</p> <p>(WRP+SLCT 1) - Use 2D keystone mode.</p> <p>(WRP+SLCT 2) - Use TWIST map #1.</p>	



**Numerics**

2D Keystone Cursor Offsets menu 3-36  
3D 3-61

3D Settings dialog 3-64  
configuration, active (fig.) 3-63  
configuration, passive (fig.) 3-63  
multiple display setup example 3-66  
requirements 3-61  
stereo sync cable 3-62

3D mode 3-65  
3D state 3-64  
3D stereo sync delay 3-65  
3D sync input 3-65  
3D sync output 3-65

**A**

accessories 7-8  
active window size 3-16  
adaptive contrast, video options 3-22  
Advanced Diagnostics menu 3-44  
*See also diagnostics and calibration*  
Advanced Edge Blending menu 3-40  
Advanced Image Settings menu 3-25  
all joined network 3-33  
array capability 3-49  
Array Color Target menu 3-48  
array status filter 3-53  
arrayLOC  
adjusting projector array colors 3-56  
Array Color Target menu 3-48  
ArrayLOC Configuration menu 3-53  
ArrayLOC menu 3-45  
ArrayLOC status 3-52  
Bright/ColorLOC Configuration menu 3-47  
color adjustment guides 3-58  
**color settings interactions** 3-61  
control array 3-55  
fine tune projector color 3-57  
fine tune projector color, meter 3-58  
**managing colors** 3-55–3-58  
Manual RGB Adjustment menu 3-42  
Projector Color Adjustment menu 3-50  
arrayLOC network 3-53  
arrow keys 3-6  
aspect ratio overlay 3-44  
auto color enable 3-51  
auto color enable, black levels and drives 3-23  
auto input level 3-23  
auto input searching 3-60  
auto key 3-3  
auto power up 3-30  
auto shutdown enable 3-30  
automatic image setup 3-16

**B**

back porch 3-24

backing up files, web UI B-8  
baud rate 3-33  
Black Level Blending menu 3-41  
black level blending procedure 3-41–3-42  
black levels 3-23  
Blanking menu 3-19  
blending edges 3-40  
blending, *see edge blending, black level blending*  
block artifact reduction 3-27  
boresight alignment 2-17  
bright/color group 3-50  
Bright/ColorLOC Configuration menu 3-47  
bright/colorLOC mode 3-45  
brightness 3-19  
*See also arrayLOC configuration*  
black level blending 3-41–3-42  
bright key 3-4  
Brightness Uniformity menu 3-37  
brightness uniformity, adjusting 3-38  
brightness threshold, warning 3-48  
brightness uniformity, disabling 3-38  
broadcast keys 3-34  
broadcasting 3-6

**C**

cascading menus 3-32  
Channel Edit menu 3-15  
channel key 3-4  
Channel Setup menu 3-12  
channels, *see inputs and channels*  
check me B-7, B-13  
chroma/luma delay, video options 3-22  
clamp location 3-24  
clear adjustments 3-51  
clearance, projector installation 2-2  
color enable 3-43  
color settings  
*See also arrayLOC*  
Color Settings menu 3-27  
**interactions** 3-61  
color space 3-20  
color, video options 3-21  
Communications menu 3-32  
configuration  
*See also 3D*  
*See also arrayLOC configuration*  
*See also color settings*  
2D Keystone Cursor Offsets menu 3-36  
Advanced Diagnostics menu 3-44  
Advanced Edge Blending menu 3-40  
Black Level Blending menu 3-41  
blending edges 3-40  
Brightness Uniformity menu 3-37  
Communications menu 3-32  
Configuration menu 3-29  
Diagnostics and Calibration menu 3-43  
display error messages 3-31

display user messages 3-31  
Edge Blending menu 3-38, 3-39  
Ethernet Settings menu 3-34  
Geometry & Color menu 3-35  
Geometry Correction menu 3-35  
Menu Preferences menu 3-31  
Output Options menu 3-29  
Power Management menu 3-30  
splash screen 3-31, 3-32  
contrast 3-4, 3-19  
copy adjustments from 3-51  
copy color space from 3-49  
copy white point from 3-49

**D**

dark interval 3-65  
date and time 3-31  
Detail Settings menu 3-26  
diagnostic test, web UI B-9  
Diagnostics and Calibration menu 3-43  
display 7-2  
display 3D message boxes 3-66  
display error messages 3-31  
display user message boxes 3-31  
domain name 3-34  
DVI (digital video input) 2-8

**E**

edge blending 3-40  
Edge Blending menu 3-38, 3-39  
electromagnetic compatibility 7-2  
EM network example 3-53  
EM stealth mode 3-30  
emissions 7-2  
enable decoder (AGC) 3-20  
enter key 3-6  
enter standby after 3-30  
environment specifications 7-7  
environmental regulations 7-1  
error code lookup table 6-3  
*See also LED lookup table*  
Ethernet network routing 3-33  
Ethernet Settings menu 3-34  
exit key 3-6  
eye motion filter 3-66  
eye-motion filter 3-27

**F**

fade time 3-60  
fan assist 3-31  
film mode detect, video options 3-22  
filter, eye-motion 3-27  
filter, video options 3-22  
fine tune projector color 3-57  
fine tune projector color, meter 3-58  
focus 2-16  
frame delay 3-29, 3-30, 3-66  
*See also arrayLOC configuration*

- frame locking 3-29, 3-60, 3-66
- free run frequency 3-30
- freeze image 3-43
- freeze image during auto setup 3-44
- front IR enable 3-34
- function key 3-5
- G**
- gamma file uploading, web UI B-8
- gamma key 3-4
- Gamma Settings menu 3-25
- gamut threshold, warning 3-48
- gateway 3-34
- general purpose input/output, *see GPIO*
- Geometry & Color menu 3-35
- Geometry Correction menu 3-35
- GPIO 2-20
- grey level 3-43
- H**
- HDMI output loop source 3-60
- HDMI, output options 3-30
- help key 3-5
- help, accessing, on-line help 3-7
- host name 3-34
- I**
- Image Settings menu 3-19
- image setup 2-16–2-19
  - boresight alignment 2-17
- images
  - See also 3D*
  - See also arrayLOC*
  - See also color settings*
  - active window size 3-16
  - adjusting brightness uniformity 3-38
  - adjusting keystone distortions 3-36
  - Advanced Image Settings menu 3-25
  - aspect ratio 3-18
  - auto input level 3-23
  - automatic setup 3-16
  - black level blending 3-41–3-42
  - black levels and drives 3-23
  - blanking 3-19
  - blending edges 3-40
  - brightness 3-19
  - color space 3-20
  - contrast 3-19
  - Detail Settings menu 3-26
  - Gamma Settings menu 3-25
  - Image Settings menu 3-19
  - Input Levels menu 3-22
  - input peak detector 3-24
  - Noise Reduction Settings menu 3-27
  - orientation 3-29
  - pixel tracking 3-18
  - resizing 3-16–3-18
  - texture enhancement 3-26
  - Video Options menu 3-20
- input cards 2-8–??
  - LED status indicators 2-8
    - settings 3-45
- input drives 3-23
- input key 3-4
- input level detector 3-44
- Input Levels menu 3-22
- input peak detector 3-24, 3-44
- input specifications 7-9–7-10
- input video black 3-21
- inputs and channels 3-10
  - Channel Setup menu 3-12
  - channels 3-11
    - copying channels 3-13
    - creating a channel 3-11
    - deleting channels 3-14
    - editing channels 3-14
    - signal types 3-13
    - switching inputs 3-10
    - using channels 3-12
- installation
  - considerations 2-1
  - folded optics 2-17
  - image setup 2-16–2-19
  - installation types 2-2
  - minimum clearance 2-2
  - mounting 2-2
    - rear screen 2-3
    - screen size and type 2-1
    - types 2-2
    - ventilation 2-1
- interconnect drawing A-1
- IP address 3-34
- J**
- joined network routing 3-33
- K**
- keep aspect on auto setup 3-18, 3-59
- keypad, *see remote control*
- keystone correction, *see geometry correction*
- keystone distortions, adjusting 3-36
- L**
- language 3-60
- language, projector menus 3-29
- large menu font 3-31
- laser pointer 3-6
- LED status indicators
  - See also error code lookup table*
  - input cards 2-8
  - lookup table 6-2
- LED strobe adjust 3-45
- lens
  - adjusting focus 2-16
  - specifications 7-3
- lens cleaning 2-21
- level detector threshold 3-44, 3-45
- light engine test pattern 3-45
- light module, replacing 5-4
- logo file uploading, web UI B-8
- M**
- MAC address 3-34
- main input 3-59, 3-66
- Main menu 3-7
- maintenance 5-1
- managing colors with arrayLOC 3-55–3-58
- Manual RGB Adjustment menu 3-42
- master projector 3-55
- master projector, *see synchronize to this projector*
- menu key 3-5
- menu location 3-31
- Menu Preferences Menu 3-31
- menus, *see OSD menus*
- minimum array frame delay 3-55
- minimum brightness 3-47
- minimum gamut 3-47
- mosquito noise reduction 3-27
- mounting projectors 2-2
- mounting specifications 7-5
- N**
- network example 3-53, 3-54
- network routing 3-33
- Noise Reduction Settings menu 3-27
- number keys 3-5
- O**
- on-screen display, *see OSD*
- optical alignment 2-16
- optics 2-17
- option card settings 3-45
- orientation 3-29
- OSD controls 3-8–3-9
- OSD key 3-5
- OSD menus 4-1
- OSD menus, web UI B-4
- OSD transparency 3-32
- output level detector 3-44
- Output Options menu 3-29
- output peak detector 3-44
- overview C-1
- P**
- PCA, *see projector color adjustment*
- PHM network example 3-54
- pixel phase 3-18
- pixel tracking 3-18
- position 2-7
- power 3-3
  - connecting 2-11
  - disconnecting 2-11
  - ON 2-11
- power management 3-30
- Power Management menu 3-30
- power requirements 7-4

power up, auto 3-30  
 proj key 3-6  
 projector  
     dimensions 7-4  
     overheating 5-1  
     synchronizing 3-46  
 projector address/id 3-33  
 projector array control 3-55  
 projector capability 3-47  
 projector clock 3-31  
 projector color adjustment 3-57  
 Projector Color Adjustment menu 3-50  
 projector status 3-59  
 projector weight 7-4

**R**

real time events (RTE), web UI B-10  
 rear screen installation 2-3  
 real time events (RTE), web UI  
     adding a scheduled event B-10  
     adding a system event B-12  
     DMX channel event, adding B-13  
 regulatory information 7-1  
 remote control 3-1  
     enable 3-34  
     enable wired 3-34  
 remote control keys 3-3–3-6  
 remote control, wired 3-3  
 requirements  
     3D 3-61  
 reset current adjustments to default 3-51  
 resizing images 3-16–3-18  
 restoring files, web UI B-8  
 RGB brightness 3-50, 3-55  
 RGB brightness target 3-50, 3-55  
 RGB quantization range, video options 3-22  
 routing, network 3-33  
 RS-232 network routing 3-33  
 RS-422 network routing 3-33

**S**

safety information 1-2, 5-1  
     labels 5-2  
     maintenance 5-1  
     regulatory 7-1  
 sampling mode, video options 3-22  
 screen 2-1  
 secondary advanced image settings 3-60  
 secondary blanking 3-59  
 secondary channel settings 3-66  
 secondary image settings 3-59  
 secondary input 3-59  
 Secondary Input and Switching menu 3-59  
 secondary input levels 3-60  
 secondary size and position 3-59  
 secondary video options 3-60  
 select white point 3-49  
 separate, network routing 3-33  
 serial command reference D-1–D-69

serial commands, web UI B-13  
 serial communication C-1  
     control types C-8  
     maximizing message integrity C-5  
     message format C-1  
     special functions C-3  
     text parameters C-4  
 serial communication options 3-32  
 Service menu 3-45  
 set array frame delay 3-54  
 set white to color temperature 3-49  
 shutdown, auto 3-30  
 shutter key 3-5  
 signal types 3-13  
 slot keys 3-4  
 sources, *see input cards*  
 specifications 7-1  
     inputs 7-9  
 splash screen 3-31, 3-32  
 split screen, video options 3-22  
 standby 3-30  
 standby active loop-through 3-60  
 status, arrayLOC 3-52  
 status, projector 3-59  
 stealth mode 3-30  
 stereo sync cable, connecting 3-62  
 strobe adjustment, LED 3-45  
 subnet mask 3-34  
 swap key 3-4  
 swap main and secondary inputs 3-59  
 synchronize frame delay 3-54  
 synchronize keys, test pattern, color enable  
     3-54  
 synchronize to this projector 3-46  
 synchronized RGB brightness 3-55  
 system integration, *see GPIO*

**T**

target color space 3-48, 3-50  
 target color values 3-49  
 target white values 3-49  
 TCP port 3-34  
 test key 3-3  
 test pattern 3-43, 3-60, 3-65  
 test pattern color swap 3-44  
 test pattern enable 3-49, 3-51  
 test pattern, geometry and color 3-35  
 test pattern, light engine 3-45  
 text size, *see large menu font*  
 texture enhancement 3-26  
 throw distance 2-6  
 tint, video options 3-21  
 tri level 3-24  
 troubleshooting 6-1

**U**

unpacking 2-4  
 user administration, web UI B-9

**V**

ventilation, installation 2-1  
 Video Options menu 3-20  
 video standards 3-21

**W**

warning brightness threshold 3-48  
 warning gamut threshold 3-48  
 warnings and error messages 6-1  
 web user interface (Web UI) B-1  
 white brightness adjustment 3-51  
 white color temperature 3-49  
 white, adjust projector array colors 3-56  
 wired keypad enabled 3-34

**X**

xy values 3-49





ASSYTECH DOCS Mirage WU-L



#### Corporate offices

USA – Cypress  
ph: 714-236-8610  
Canada – Kitchener  
ph: 519-744-8005

#### Worldwide offices

United Kingdom  
ph: +44 118 977 8000  
France  
ph: +33 (0) 1 41 21 00 36  
Germany  
ph: +49 2161 664540

Eastern Europe  
ph: +36 (0) 1 47 48 100  
Middle East  
ph: +971 (0) 4 299 7575  
Spain  
ph: + 34 91 633 9990

Singapore  
ph: +65 6877-8737  
Beijing  
ph: +86 10 6561 0240  
Shanghai  
ph: +86 21 6278 7708

Japan  
ph: 81-3-3599-7481  
South Korea  
ph: +82 2 702 1601