

Roadster / Mirage S⁺

LAMP AND FILTER REPLACEMENT INSTRUCTIONS





INTRODUCTION

Use the following instructions when replacing the lamp or filters in any of the projectors listed in Table 1, below. The lamp is located at the rear of the projector (below the input panel) and can be accessed by opening the lamp door. Use only a Christie approved *Lamp and Filter Kit* for your specific projector model.

Table 1. Projector Models

| Projector Model | Model Number | Lamp Type (Watts) | Lamp/Filter Kit Required |
|-----------------------------|--|-------------------|---|
| Roadster S ⁺ 12K | 38-DSP210-01 38-DSP210-02 38-DSP210-52 | 1.9kW | 03-900519-01P 03-900519-01P 03-900519-51P |
| Roadster S ⁺ 16K | 38-DSP214-01 38-DSP214-03 38-DSP214-53 | 2.4kW | 03-900518-01P 03-900518-01P 03-900518-51P |
| Mirage S ⁺ 14K | 38-DSP214-04 38-DSP214-54 | 2.4kW | 03-900518-01P 03-900518-51P |
| Roadster S ⁺ 20K | 104-001001 104-001101-01 | 3.0kW | 003-000306 003-000306-02 |

WARNINGS

-  *Lamp replacement MUST be performed by a qualified service technician.*
-  *Cool the lamp completely and handle by the housing only.*
-  *Install the correct wattage lamp supplied by Christie (Refer to Table 1. Projector Models) and read the Lamp Replacement Procedure in its entirety before proceeding.*
-  *Do not touch the glass surface of the lamp. Fingerprints left on the surface can lead to an intense accumulation of heat known as a "hotspot", which could potentially result in the lamp shattering. It is recommended to wear clean, lint-free gloves and a face shield when working with the lamp.*

S⁺ 12K / 14K / 16K / 20K LAMP & FILTER INSTRUCTIONS

LAMP REPLACEMENT PROCEDURE

Please read before proceeding.



WARNING

Always power down and unplug the projector prior to servicing.
Allow the lamps to cool before handling.

STEP 1 - TURN THE LAMP OFF

Press  (power) to turn the projector off. Allow the cooling fans to stop automatically (approximately five minutes) before proceeding with Step 2. This wait period is also required to allow the lamp to sufficiently cool before handling.

STEP 2 - UNPLUG THE PROJECTOR

When the cooling fans have stopped, turn the projector's main switch off and unplug from the main power source.

STEP 3 - OPEN THE LAMP DOOR



WARNING

Protective gear required. Wear a face shield.

Use a #2 Phillips screwdriver to loosen the ¼-turn lock screws (2) securing the lamp door, located at the rear of the projector below the input panel. Refer to Figure 1.

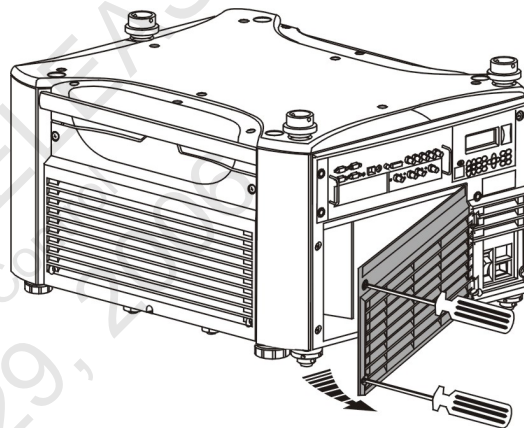

Figure 1. Open Lamp Door

STEP 4 - REMOVE LAMP RETAINING BAR

Use a #2 Phillips screwdriver to remove the two screws that secure the retaining bar along the bottom edge of the lamp module. Refer to Figure 2. Swing the bar to the side - it is hinged on the left.

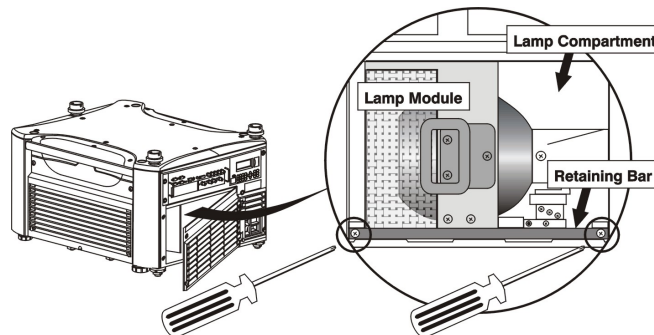

Figure 2. Remove Retaining Bar

S⁺ 12K / 14K / 16K / 20K LAMP & FILTER INSTRUCTIONS

STEP 5 - REMOVE THE LAMP MODULE

Firmly grasp the handle and pull the lamp module straight out of the projector, as shown in Figure 3. Discard the lamp using safe disposal/recycling practices.

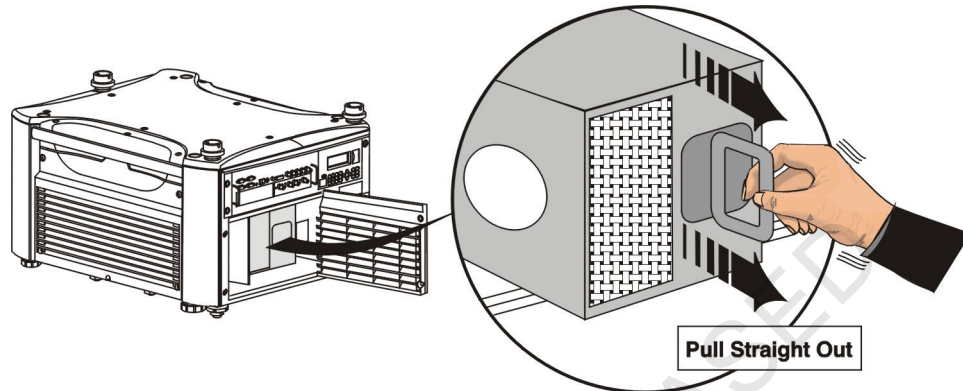

Figure 3. Remove Lamp Module

STEP 6 - INSERT THE NEW LAMP MODULE



WARNING

Improper installation could cause a serious meltdown inside the projector.

NOTE

The lamp module must make full contact with the lamp connectors. Increased resistance indicates initial contact with the connectors – push firmly at this point to make full contact.

Align the base plate of the new lamp module under both side alignment guides. Refer to Figure 4. Slide the module fully into the projector in the same orientation the old lamp module was removed. Push with normal force until the resistance increases and then firmly push the module another ½ inch.

Right side of lamp compartment shown.

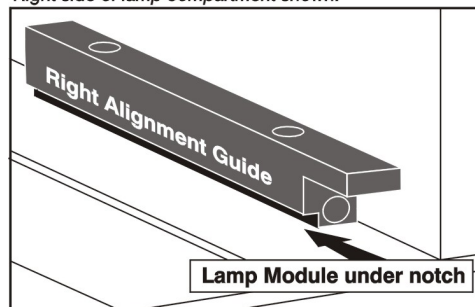

Figure 4. Alignment Guides

S⁺ 12K / 14K / 16K / 20K LAMP & FILTER INSTRUCTIONS

STEP 7 - RE-INSTALL LAMP RETAINING BAR

- (a) Position the retaining bar along the bottom edge of the lamp module, with the ends positioned under the alignment guides. If the bar does not fit, push the lamp module in further.



IMPORTANT



The tightening order of the screws is critical for proper lamp contact and alignment.

- (b) Secure screw **B** until just engaged.
- (c) Secure screw **A** until just engaged.
- (d) Go back and forth between **A** and **B** to lock the bar in place with even pressure and correctly position the lamp module. Refer to Figure 5.

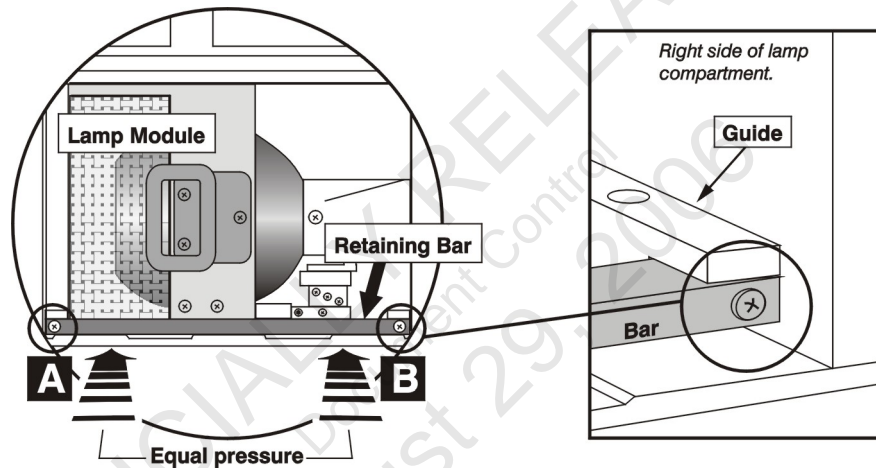

Figure 5. Install Retaining Bar

STEP 8 - CLOSE LAMP DOOR

Close the lamp door and lock the ¼-turn lock screws (2).



IMPORTANT



The lamp module is calibrated for maximum performance and brightness in this projector.
Do not attempt to re-align or adjust the lamp module.

STEP 9 - INSTALL THE AIR FILTER

While the projector is still off, replace the air filter. For more information, refer to the *Filter Replacement Procedure*, on page 6.

S⁺ 12K / 14K / 16K / 20K LAMP & FILTER INSTRUCTIONS

STEP 10 - RECORD THE SERIAL NUMBER OF THE NEW LAMP



IMPORTANT

Neglecting to enter a serial number causes the lamp timer to NOT reset to "0" and may cause the lamp life limit to expire prematurely.

- (a) Plug in the projector and power it up.
- (b) In the Lamp menu, select "Change Lamp". Refer to Figure 6, shown below.
- (c) In the Lamp S/N text box, enter the serial number.
- (d) Press ENTER to record the number and to reset the lamp timer. The timer will now begin to log time for the new lamp.

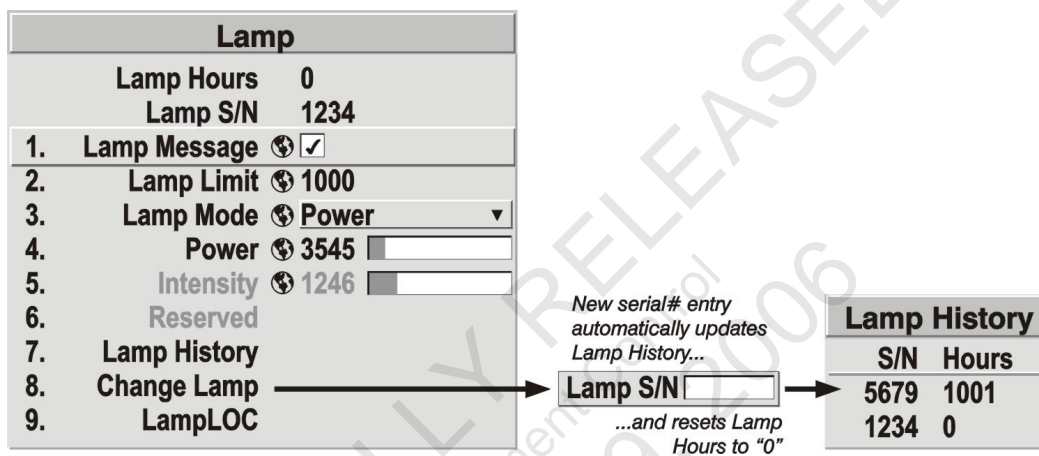

Figure 6. Lamp Menu

FILTER REPLACEMENT PROCEDURE

NOTE

This procedure should be undertaken immediately after Step 8 of the *Lamp Replacement Procedure*.

The filter, located at the front side of the projector, should be changed whenever the lamp is replaced. If operating in an extremely dusty environment the filter may have to be replaced sooner. Use the filter provided in the Christie approved *Lamp and Filter Kit* for the specific projector model. For more information, refer to Table 1. Projector Models.

STEP 1 – TURN OFF THE PROJECTOR, COOL and UNPLUG

Before removing or installing a filter, turn off the projector and allow it to cool for five minutes before unplugging.

STEP 2 - REMOVE FILTER DOOR

NOTE

When operating a Roadster S+20K also remove the triangular metal filter brace.

Loosen the ¼-turn screw at the top of the filter grille/door. Lift the door away from the projector. Refer to Figure 7.

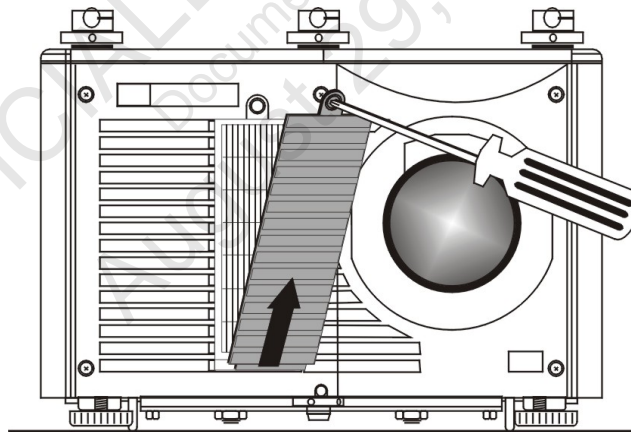

Figure 7. Remove Filter Door

S⁺ 12K / 14K / 16K / 20K LAMP & FILTER INSTRUCTIONS

STEP 3 - REPLACE FILTER

Remove the old filter and insert a new one. Follow the airflow arrows for correct orientation. Refer to Figure 8. The Roadster S+20K model has a rhomboid-shaped filter; therefore, insert the sharply angled corner first – place fully back on the left. Ensure the triangular metal filter brace is installed after the filter has been positioned. Refer to Figure 9.

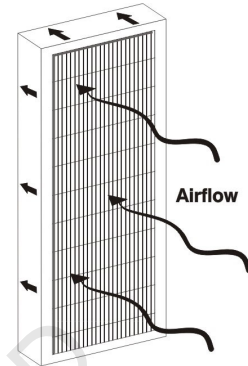

Figure 8. Filter Airflow

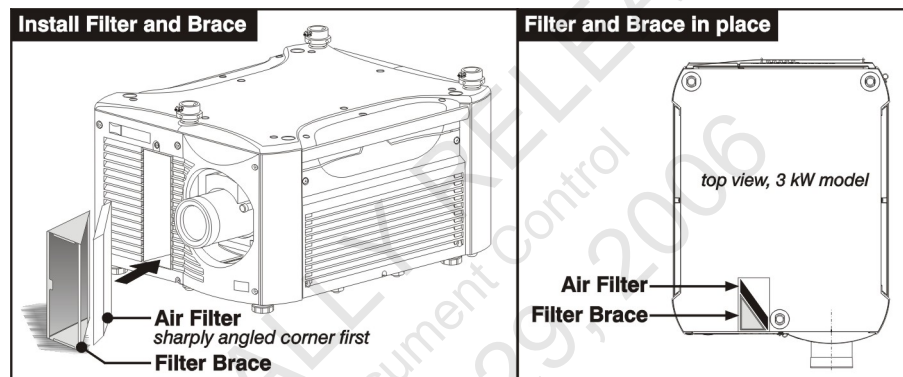

Figure 9. Installing the Angled Air Filter (ROADSTER S+20K ONLY).

Available Filter Replacement Kits:

- 03-900546-01P: Five pack filter kit for 2.0kW and 2.4kW projectors
- 003-000-310: Five pack filter kit for 3.0kW projectors

STEP 4 - RE-INSTALL THE FILTER GRILLE/DOOR

Tighten the single top screw to secure the filter grille/door.

S⁺ 12K / 14K / 16K / 20K LAMP & FILTER INSTRUCTIONS



NORTH AMERICA

CHRISTIE Digital Systems, Inc.

809 Wellington St. North
Kitchener, Ontario, Canada N2G 4Y7
Tel. 519-744-8005 (General)
Toll Free 1-800-221-8025 (Technical Support)
Fax 519-749-3302 (Service)

CHRISTIE Digital Systems, Inc.

10550 Camden Drive
Cypress, CA 90630 USA
Tel. 714-236-8610 (General)
Toll Free 1-800-221-8025 (Technical Support)
Fax 519-749-3302 (Service)

EUROPE

CHRISTIE Digital Systems, Inc.

View Point
200 Ashville Way
Wokingham, Berkshire RG41 2PL
United Kingdom
Tel. +44-118-977-8111
Fax +44-118-977-8112

CHRISTIE Digital Systems, Inc.

Willicher Damm 129
D-41061 Mönchengladbach
Germany
Tel. +49-2161-664540
Fax +49-2161-664546

CHRISTIE Digital Systems, Inc.

7, av Georges Pompidou
92593 Levallois-Perret Cedex
France
Tel. +33-(0)1-47-48-28-07
Fax +33-(0)1-47-48-26-06

ASIA-PACIFIC / OTHER

CHRISTIE Digital Systems, Inc.

627A Aljunied Road
05-02 Biz Tech Centre
Singapore 389842
Tel. 65-6877-8737
Fax 65-6877-8747

CHRISTIE Digital Systems, Inc.

Rm. 1109-1116 Shartex Plaza
No. 88 Zun Yi South Road
Shanghai, 200336
People's Republic of China
Tel. +86-21-6278-7708
Fax +86-21-6270-5816

CHRISTIE Sales (Canada)

Tel. 1-800-265-2171
Fax 519-749-3136

CHRISTIE Sales (U.S.)

Tel. 1-800-407-7727 or 1-866-880-4462
Fax 714-503-3375