



Title	TR-MAN-HC10	Creation	October 2013 <i>by</i> Brandon Packer	Revision	October 2015 <i>by</i> Adam Blanchard
	Operator's Manual – HC10				

Table of Contents

Table of Contents	1
HC10 Soft Hose Caddy	2
Warranty Policy	3
When Applying Liquid Manure	4
Safety Precautions	5
Safety Decals	6
Hydraulic Connections.....	11
Changing Tongue Positions of Your Caddy.....	16
Unloading Your Hose Caddy	22
Temporary Hose Repair	25
Loading Your Hose Caddy from Rear.....	26
Loading Your Hose Caddy from Front	28
Parts Section	31
Required Maintenance	49
Technical Specifications	53
HC10 Soft Hose Caddy Trailer Dimensions.....	54
HC10 Soft Hose Caddy Cartridge Dimensions	55
HC10 Soft Hose Caddy Tongue Positions.....	56
Useful Information	57
Revision History.....	58

HC10 Soft Hose Caddy

We would like to thank you for purchasing your new **Cadman HC10 Soft Hose Caddy**. You have purchased a product of superior quality that will serve your needs for a long time provided you follow this manual and safety procedures.



Figure 1 – HC10 Soft Hose Caddy

img-00761

Before operating your **Cadman HC10 Soft Hose Caddy**, inspect the machine for any damage or parts which may have come loose during shipping. **REPORT ANY DAMAGE TO CADMAN POWER EQUIPMENT LIMITED OR YOUR LOCAL DEALER IMMEDIATELY!**

Warranty Policy

CADMAN POWER EQUIPMENT LIMITED warrants that each machine it manufactures shall be free from defects in materials and workmanship. The terms of this warranty are as follows:

- All components manufactured by **CADMAN POWER EQUIPMENT LIMITED** shall be warranted for a period of one (1) year from the date of delivery, except the frame and hose drum structures which shall be warranted for a period of three (3) years.
- **CADMAN POWER EQUIPMENT LIMITED** makes no warranty whatsoever in regard to tires, engines, and other trade accessories used on its equipment. The customer shall rely solely on the warranties offered (if any) by the respective manufacturer of these trade accessories.

The sole obligation to **CADMAN POWER EQUIPMENT LIMITED** under this warranty is limited to the repair or replacement of any part it manufactured, which, in the judgment of **CADMAN POWER EQUIPMENT LIMITED**, failed under normal and proper use and maintenance due to defective materials or workmanship. All freight charges incurred shall be the sole responsibility of the customer.

CADMAN POWER EQUIPMENT LIMITED and its dealers (**who are neither authorized nor qualified to undertake any obligations on behalf of CADMAN POWER EQUIPMENT LIMITED**) **DO NOT**, under any circumstances, accept any responsibility for any losses or costs incurred due to parts failure and/or delays during the parts replacement process.

This warranty will be considered void if any alterations or modifications have been made to the machine without the express written consent of **CADMAN POWER EQUIPMENT LIMITED** outlining the nature and the extent of such modifications.

CADMAN POWER EQUIPMENT LIMITED reserves the right to change specifications and designs without notice or incurring obligation.

The warranties expressed herein are non-transferable and replace any other warranties, either written or verbal, which may have been given or implied.

When Applying Liquid Manure

Current and pending laws in agricultural regions of North America change the ways in which the agricultural community needs to manage their liquid animal waste products. As a manufacturer of agricultural equipment, we feel it necessary to make you aware that the municipal, regional and state governing bodies in your area may have created new laws or updated current laws for nutrient handling practices and procedures. The changes in these laws typically target run-off prevention and soil nutrient loading.

Run off may result from several factors. Some (but not all) of the factors are:

- Incorrect application
- Difficult application areas containing steep hills or other features that may make run off more likely to happen
- Changes in weather that would allow run off to happen (sudden storms just before or just after applying, ground frost, etc....)

Constant watch must be kept and immediate action taken when needed to prevent run off from happening.

Soil nutrient loading depends on several variables. Some (but not all) of these variables are:

- The type of crop(s) being grown
- The type of soil the crop(s) are growing in
- Nutritional value of what you are applying
- Nutritional needs of the crop(s) and soil they are growing in

Application timing, nutritional value of what you are applying, and the type of soil will determine the intake rate at which liquid may be applied. Soil analysis taken at appropriate times will help you create a correct application plan for your crop(s). In addition; local colleges, universities, and agricultural extension services are a good source of information. They may be able to help you create an application program that will help prevent problems with your application.

CADMAN POWER EQUIPMENT LIMITED is unable to provide up-to-date recommendations for the laws you must follow in your area. It is your responsibility to make yourself aware of and follow the law in your area. Please contact your local agricultural representative to obtain the latest information for legal handling and application of nutrient.

Safety Precautions

Please take the time to read and understand this manual to avoid errors and unnecessary risks. If you have any questions or concerns, please contact **CADMAN POWER EQUIPMENT LIMITED** or your local dealer/distributor.

FAILURE TO FOLLOW ALL SAFETY INSTRUCTIONS CAN RESULT IN DEATH OR SERIOUS INJURY FOR YOU AND/OR ANY SPECTATORS.

- **DO NOT** move or operate this machine until you have read and understand these instructions in this manual.
- **NEVER** allow untrained persons to operate this machine.
- **DO NOT** attempt to service this machine while it is in operation.
- **MAKE SURE** all mechanical and hydraulic tension has been released before attempting any service on the machine.
- **CHECK** all fasteners (nuts and bolts) regularly for tightness.
- **PERFORM REQUIRED MAINTENANCE** as prescribed or as necessary to keep this machine in safe operating condition.
- **KEEP ALL SPECTATORS** at a safe distance.
- **STAY CLEAR** of high pressure supply lines, especially when you first start up the system.
- **DO NOT** remove or alter any shielding on this machine.
- **MAKE SURE** that the machine is securely anchored (using a tractor) before unwinding the hose.
- **KEEP CLEAR** of all moving parts.
- **NEVER** tow this machine at speeds greater than **55 mph [85 km/h]** and be certain the tow vehicle has adequate braking capacity to maintain safe control at all times.
- **NEVER** transport this machine with boom arms extended.
- **REGULAR INSPECTION** of your pipe/hose couplings, tubing and gaskets must be a part of your regular set-up routine. Any defective parts **MUST** be replaced or repaired before the machine is put into service.



This symbol, the **safety-alert symbol**, indicates a hazard. When you come across the **safety-alert symbol** in this manual, make sure you fully understand and abide by the given instructions or warnings.

Safety Decals

Cadman Power Equipment Limited has determined the potential hazards on your HC10 Hose Caddy and has labeled the machine accordingly. The safety decals on this machine are there to warn operators of potential hazards. Each safety decal on this machine contains a Signal Word Panel which shows the degree of hazard. Definitions of the Signal Words are as noted below.



Figure 2 – Danger Decal

img-00340-A

- **DANGER** - an immediate, hazardous situation that if not avoided, **WILL RESULT IN DEATH OR SERIOUS INJURY.**



Figure 3 – Warning Decal

img-00340-B

- **WARNING** - a potentially hazardous situation that if not avoided could result in death or serious injury. This includes hazards that are exposed when guards are removed.



Figure 4 – Caution Decal

img-00340-C

- **CAUTION** - a potentially hazardous situation that if not avoided may result in minor or moderate injury.

- All safety decals must be clean, clear, and easy to read
- Replace any decal that is not in good condition
- Replace any missing decals, it is important to double check that all labels are on your machine, especially if you have modified your machine or have had your machine serviced

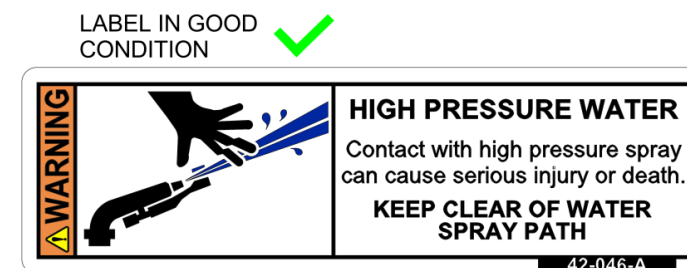
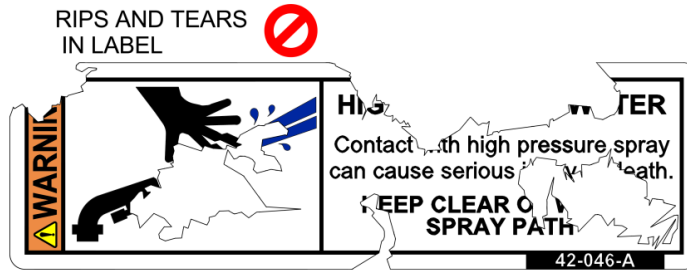

Figure 5 – Replace Decals

img-00131-B

Location of Safety Decals

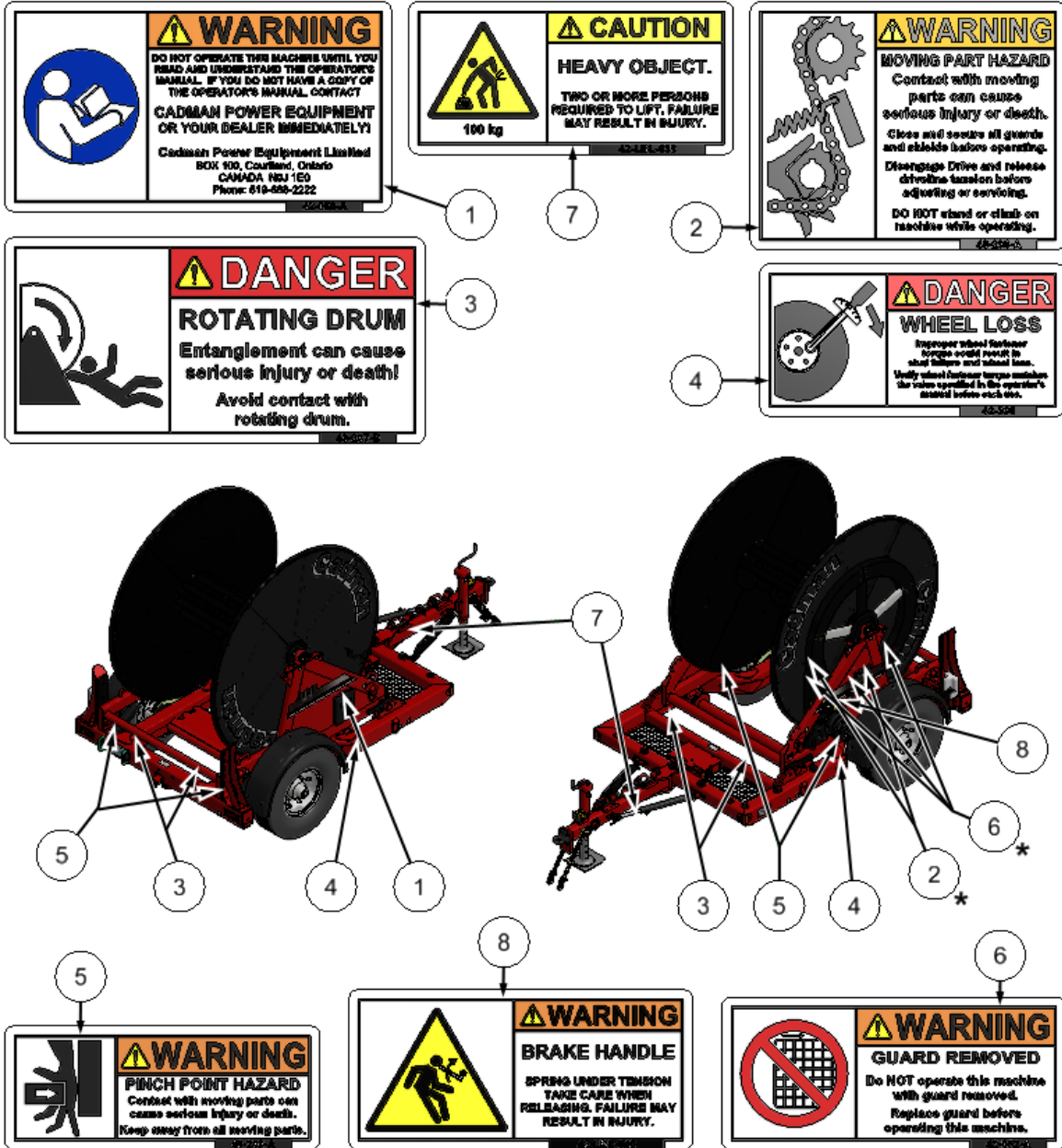

Figure 6 - Safety Label Location (*Behind Shield)

img-00577

To obtain the required replacement safety decals contact **Cadman Power Equipment Limited** or your **Local Dealer**. Re-install all decals in the proper location on the machine.

Location of Safety Lights

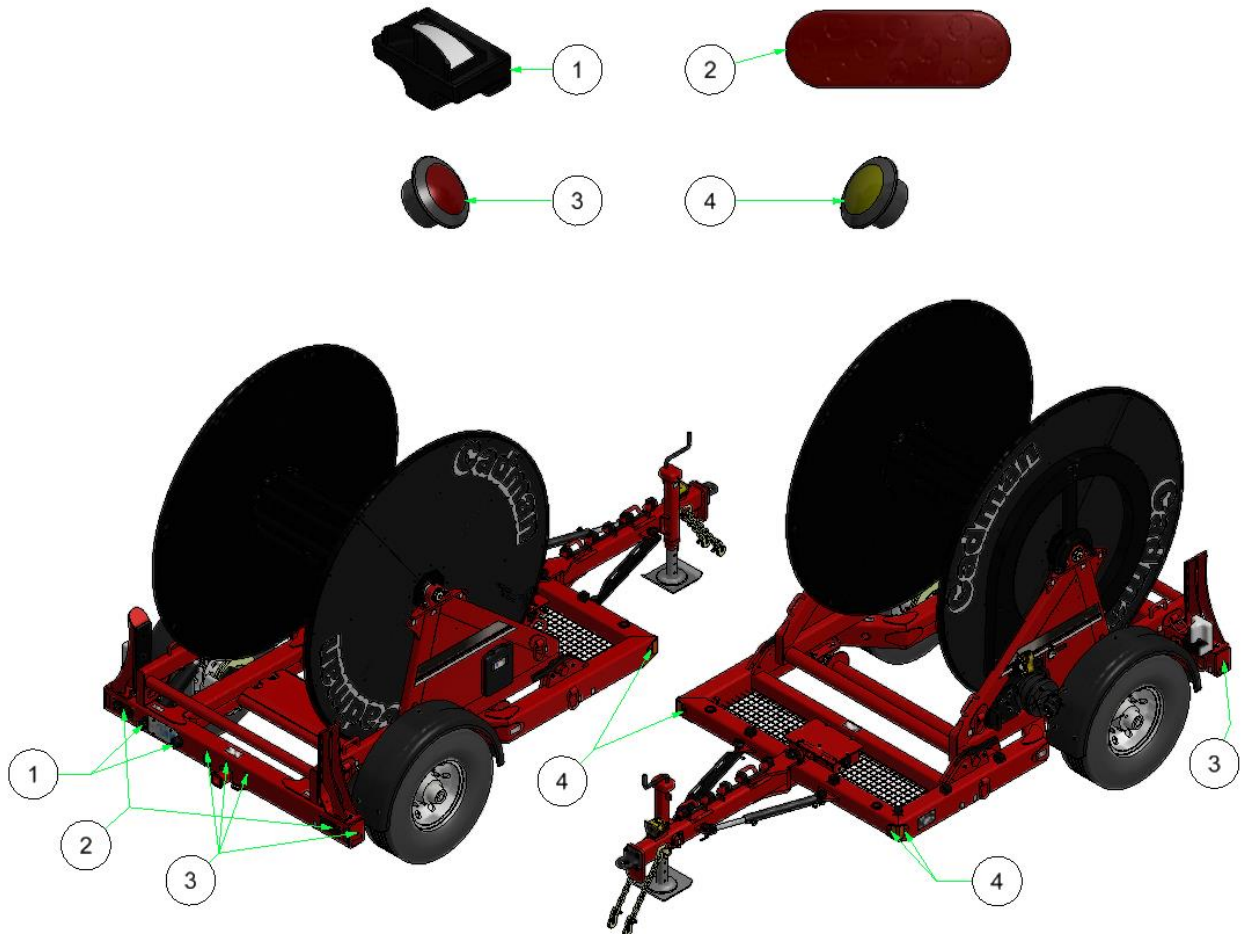

Figure 7 – HC 10 Safety Lights Locations

img-00770

ITEM	DESCRIPTION	PART NUMBER	QTY
1	LED - LICENSE PLATE LIGHT	42-ELC-008	2
2	LED - BRAKE LIGHT	42-ELC-006	2
3	LED - SAFETY LIGHT RED	42-ELC-007RED	4
4	LED – SAFETY LIGHT AMBER	42-ELC-007AMB	4

To obtain replacement safety lights contact **Cadman Power Equipment Limited** or **your Local Dealer**. Re-install all damaged or burnt out lights in the proper location on the machine.

Location of Safety Shields

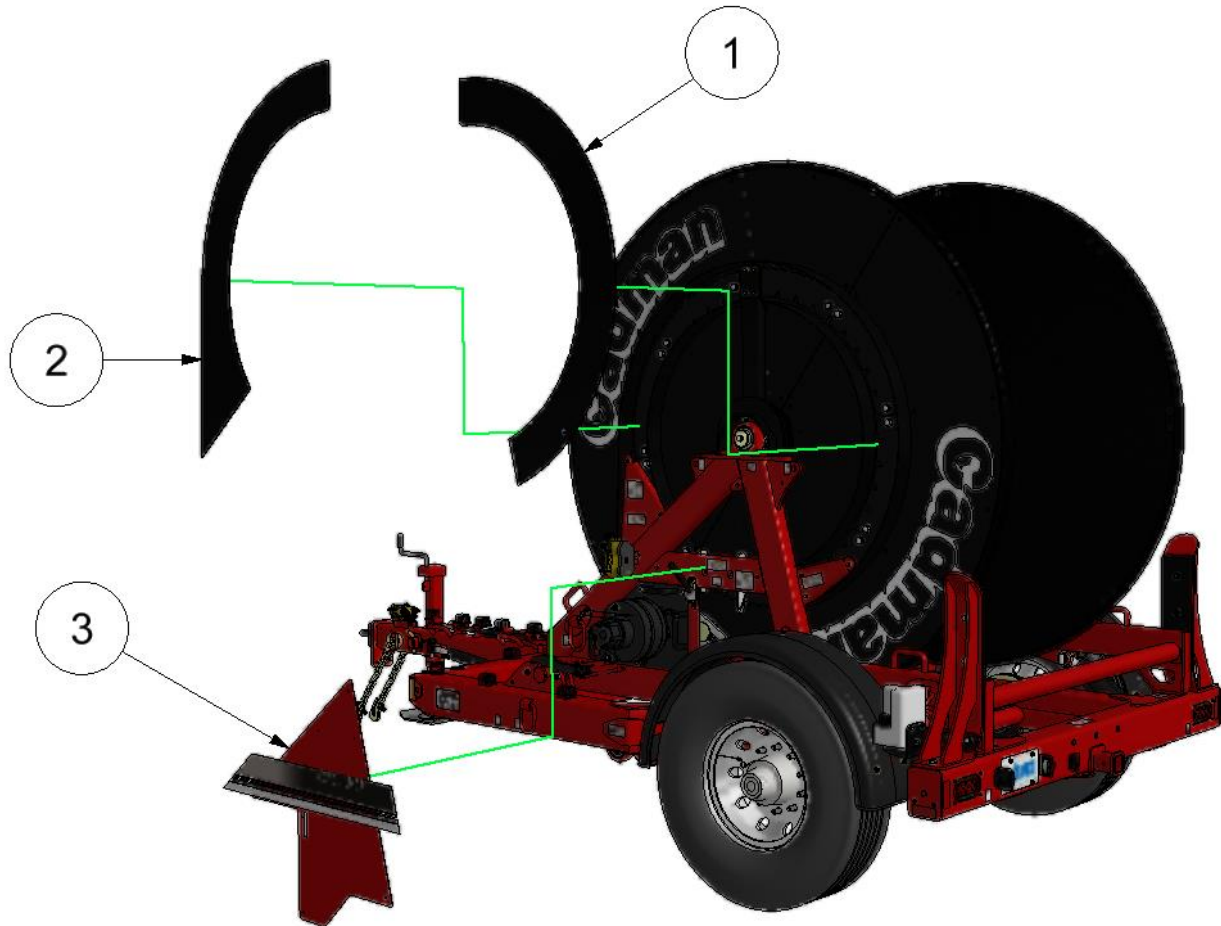

Figure 8 - Safety Shields Location

img-00580

ITEM	DESCRIPTION	PART NUMBER	QTY
1	SHIELD - FRONT CHAIN GAURD	64-710-A	1
2	SHIELD - BACK CHAIN GAURD	64-713-A	1
3	SHIELD - TENSIONER PLATE GRAUD	64-610	1

To obtain replacement safety shields contact **Cadman Power Equipment Limited** or your **Local Dealer**. Re-install all shields in the proper location on the machine before any operation.

Hydraulic Connections

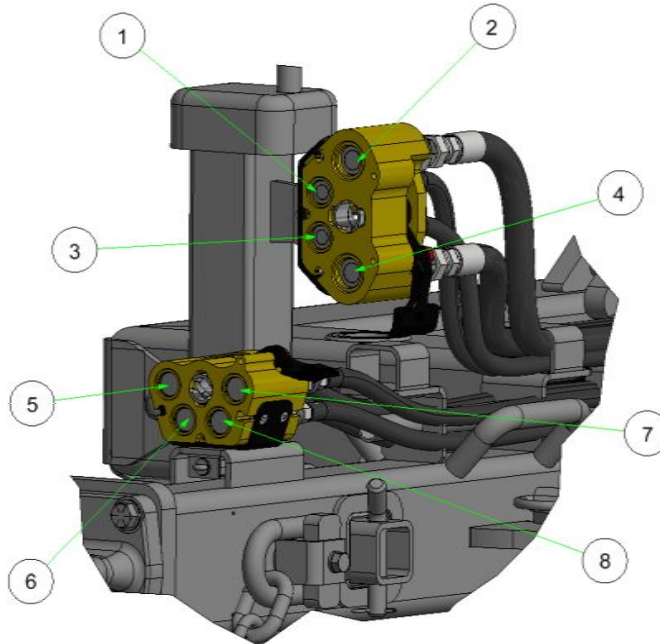

Figure 9 – Hydraulic Connection Locations

img-00590

ITEM	DESCRIPTION	QTY
1	DRUM MOTOR – BRAKE LINE	1
2	DRUM MOTOR - REVERSE LINE	1
3	DRUM MOTOR - CASE DRAIN	1
4	DRUM MOTOR - FORWARD LINE	1
5	TRAILER TONGUE - RETRACT	1
6	TRAILER TONGUE - EXTAND	1
7	CRADLE LIFT - EXTAND	1
8	CRADLE LIFT - RETRACT	1



Connection and disconnection of hydraulic hoses must **ONLY** be done when the machine is shut down and is in a non-loaded condition. This means that all mechanical and hydraulic pressure has been released. Make sure to carefully clean all surfaces of contact before connection of hydraulic hoses or the multi-port take place. Replace all multi-port dust caps when not in use. When coupling the female and male multiport units together watch that you do not catch your fingers or other object between the connection.

Connecting the Multi-port units



Figure 10 – Removal of Dust Caps
img-00593 & img-00597



Figure 11 –Unlocking the Multi-port
img-00593 & img-00594



Figure 12 – Connection of Multi-port
img-00595



Figure 13 – Locking the Multi-port
img-00596

Step 1

Remove dust caps and make sure surfaces are clean before connection of the multi-port.

Step 2

Press the lock button on the lever and turn it to the vertical position.

Step 3

Push the multi-port units together as far as possible.



Take caution not to get any objects or your fingers caught between the plates

Step 4

Push the lever to the lowered position to lock the multi-port together.

Disconnecting the multi-port connection units



Turn off and depressurize the hydraulic system before disconnection. Pressure left in the hoses can result in a recoil effect during disconnection. Be sure to grip the lever firmly.



Figure 14– Releasing the Lock

img-00593 & img-00597

Step 1

Press the lock button and push the lever to a vertical position



Figure 15 – Separating the Multi-port

img-00598

Step 2

Pull the multi-port connection apart.



Figure 16 – Replace Dust Caps

img-00599 & img-00600

Step 3

Make sure the surfaces are clean and replace the dust caps.



Position the male/moving plate so that it does not risk being damaged.

Connecting/Disconnecting Hoses to the multi-port Unit



Turn off and depressurize the hydraulic system before disconnection. Pressure left in the hoses can result in a recoil effect during disconnection. Be sure to grip the lever and hose firmly.

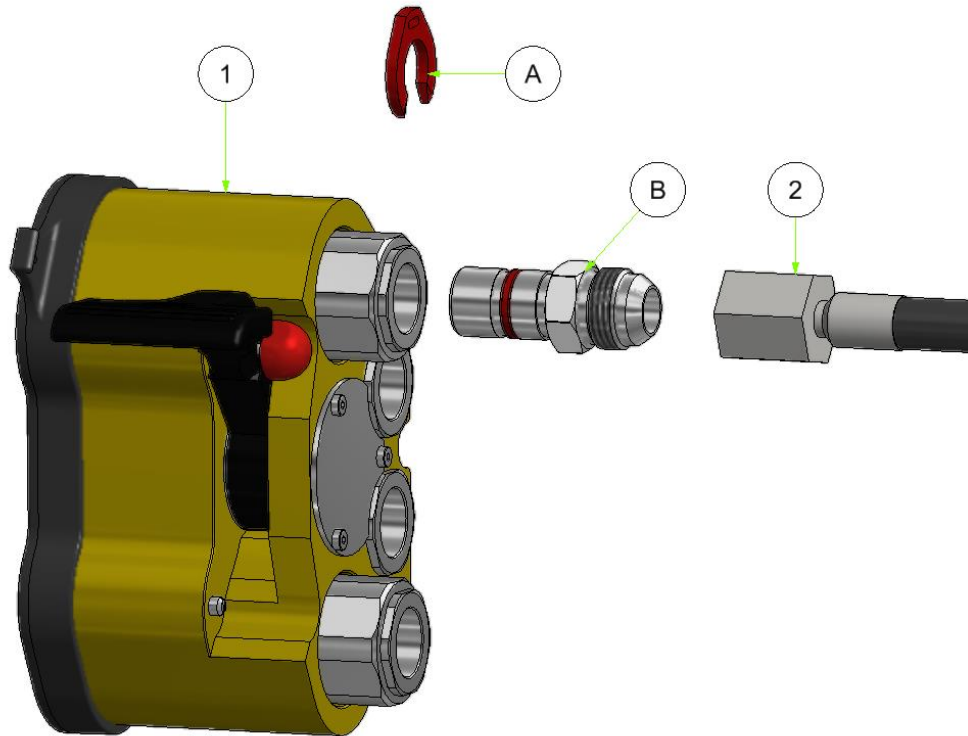

Figure 17 – Hydraulic Hose Connection

img-00634

ITEM	DESCRIPTION	QTY
A	MULTI-PORT - WEO ASSEMBLY STOP CLIP	1
B	MULTI-PORT - WEO NIPPLE	1
1	CEJN – MULTI-PORT 12.5/19	1
2	HYDRAULIC HOSE - 3/8" HOSE	1



Be sure to clean all connecting ends of hydraulic hose and multi-port units before contact to eliminate contamination of the hydraulic system..

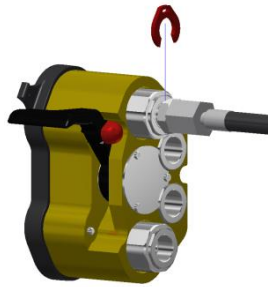

Figure 18 – Remove Assembly Stop Clip

img-00635

Step 1

Remove the assembly stop clip.

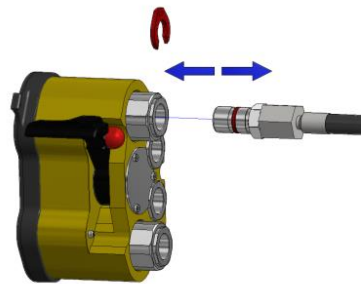

Figure 19 – Disconnect the WEO Hose

img-00636

Step 2

Push the WEO nipple connection all the way in. Then pull out the hose from the multi-port.

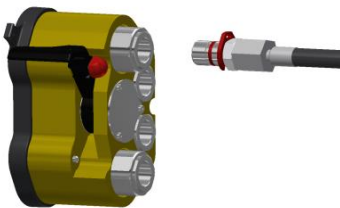

Figure 20 – Replace Assembly Stop Clip

img-00637

Step 3

To connect the hose to the multi-port place the assembly stop clip back on the WEO nipple.

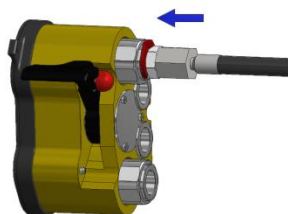

Figure 21 – Connecting the WEO

img-00638

Step 4

Push the WEO in as far as it goes to connect the hose to the multi-port. Pull gently on the hose to confirm the connection.

Changing Tongue Positions of Your Caddy



Prior to changing the HC10 hose caddy trailer tongue position the machine must be shut down and in a non-loaded condition. This means that all mechanical and hydraulic tension has been released from the hydraulic hose system.

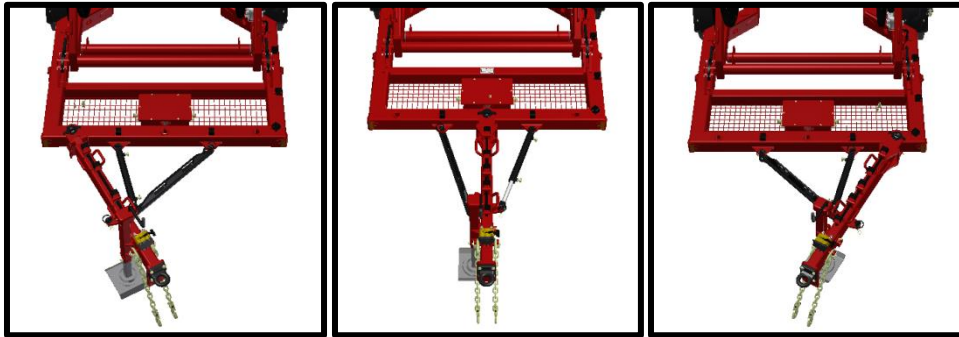

Figure 22 – Different Tongue Positions Right through Left

img-00614 & img-00615 & img-00616

Right Hand Tongue Position

Complete this section to change the tongue location to the right on your caddy.

Step 1

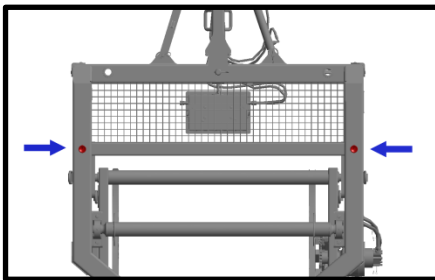

Place jacks in the left and right jack point positions of the caddy.

Figure 23 – Jack locations (Bottom View)

img-00617

Step 2

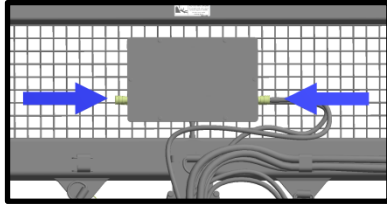

Figure 24 – Move Hydraulic Hoses

img-00618

Unhook and move the two hydraulic hoses from the one side of the box to the other side.

Step 3

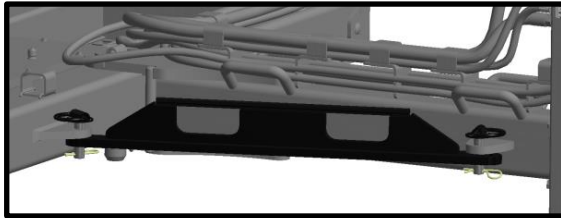

Figure 25 – Remove Brace

img-00619

Remove the Tongue Brace.

Step 4

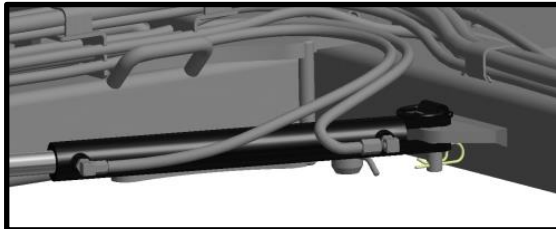

Figure 26 – Remove Cylinder Pin

img-00620

Remove the pin from the cylinder on the side attached to the trailer.

Step 5

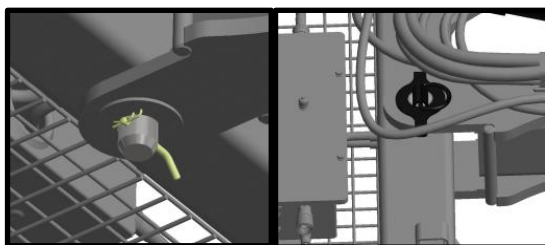
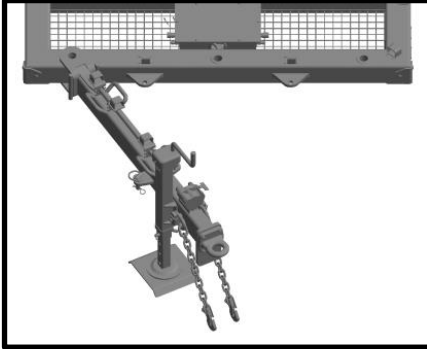

Figure 27 – Remove Main Pin

img-00621 & img-00622

Remove the main locating pin from the Trailer Tongue.

Step 6



Move the tongue to the right location with another able bodied person.



The trailer tongue weights approximately 410lbs (185 kg). Do not move the Trailer Tongue if you are not physically fit, and do not move the Trailer Tongue without assistance.

Figure 28 – Move Tongue Positions

img-00623

Step 7

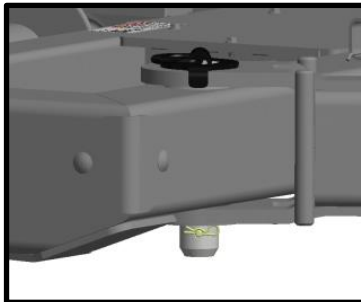

Replace the main locating pin for the Trailer Tongue.

Figure 29 – Replace Main Tongue Pin

img-00624

Step 8

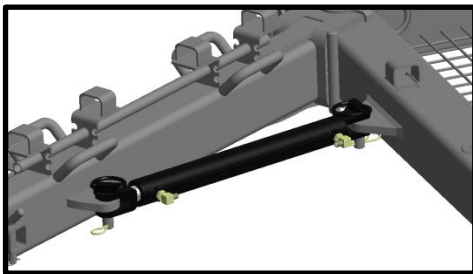

Replace the hydraulic cylinder of the Trailer Tongue using the locating pins.

Figure 30 – Replace Hydraulic Cylinder

img-00625

Step 9

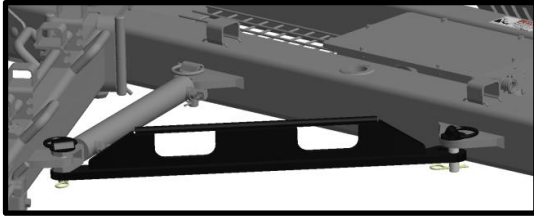

Figure 31 – Replace Tongue Brace

img-00626

Replace the Trailer Tongue Brace as shown for the tongue in the right side position.

Step 10



Figure 32 – Right Tongue Position

img-00627

Once all pins are in place and everything is connected, you can remove the jacks. The trailer is now setup in the Right Tongue Position and is ready for transportation. To move the tongue back to the center location follow these steps in reverse order

Left Hand Tongue Position

Complete this section to change the tongue location to the left on your caddy.

Step 1

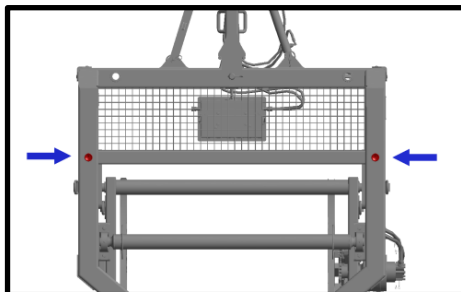

Figure 33 – Jack locations (Bottom view)

img-00617

Starting from the center position, place jacks in the left and right jack point positions of the caddy.

Step 2

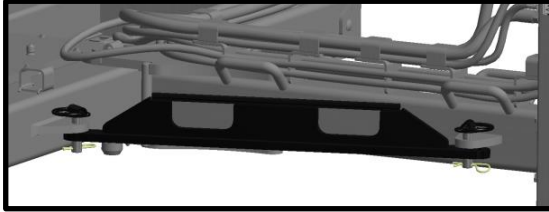

Figure 34 – Remove Brace

img-00619

Remove the Tongue Brace and set aside.

Step 3

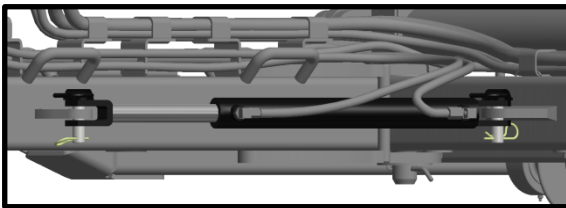

Figure 25 – Remove Cylinder Pins

img-00628

Remove both pins from the cylinder and set the cylinder aside.

Step 4

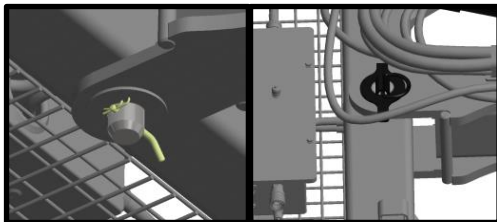

Figure 36 – Remove Main Locator Pin

img-00621 & img-00622

Remove the main locating pin from the Trailer Tongue.

Step 5

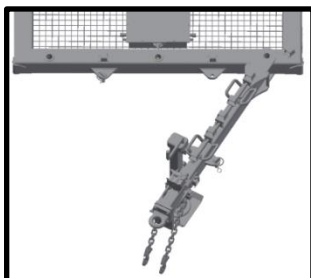

Figure 37 – Move Tongue Positions

img-00629

You now can move the Tongue to the left location with another able bodied person.



The trailer tongue weights approximately 410lbs (185 kg). Do not move the Trailer Tongue if you are not physically fit, and do not move the Trailer Tongue without assistance.

Step 6

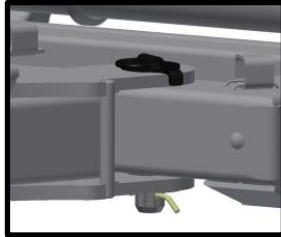

Figure 38 – Replace Tongue Pin

img-00630

Replace the main locating pin for the Trailer Tongue.

Step 7

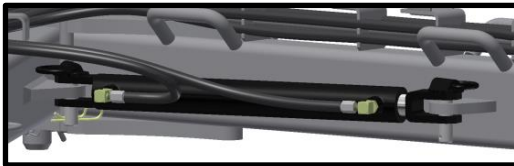

Figure 39 – Replace Hydraulic Cylinder

img-00631

When you attach the hydraulic cylinder on the right side of the tongue for the left side Tongue setup the cylinder must be rotated 180° so the hydraulic connections face away from the tongue so they will not get damaged.

Step 8



Figure 40 – Replace Tongue Brace

img-00632

Replace the Trailer Tongue brace as shown for the tongue in the left side position.

Step 9

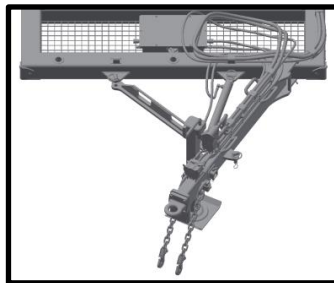

Figure 41 – Left Tongue Position

img-00633

Once all pins are in place and everything is connected, you can remove the jacks. The trailer is now setup in the Left Tongue Position and is ready for transportation. To move the tongue back to the Center Location follow these steps in reverse order.

Unloading Your Hose Caddy

Complete the following instructions to unload your HC10 Soft Hose Caddy.

Step 1

Connect the hydraulic multi-port 12.5/19 (Female) of the caddy to the primary hydraulic multi-port 12.5/19 (Male) of the Power Pak. Review your tractor's operator's manual or contact your tractor dealer for the location of this port. Connect the remaining cylinder hose pair.



It is important to ensure that the case drain hose is connected to a restriction free drain port on the vehicle. This port **MUST** not exceed a working pressure of 100 psi [6.9 bar]. Connecting the case drain line to a pressurized port **WILL** result in motor and/or machine damage.

Step 2

Connect the break-away cable and lock prior to moving your **HC10 Soft Hose Caddy**.

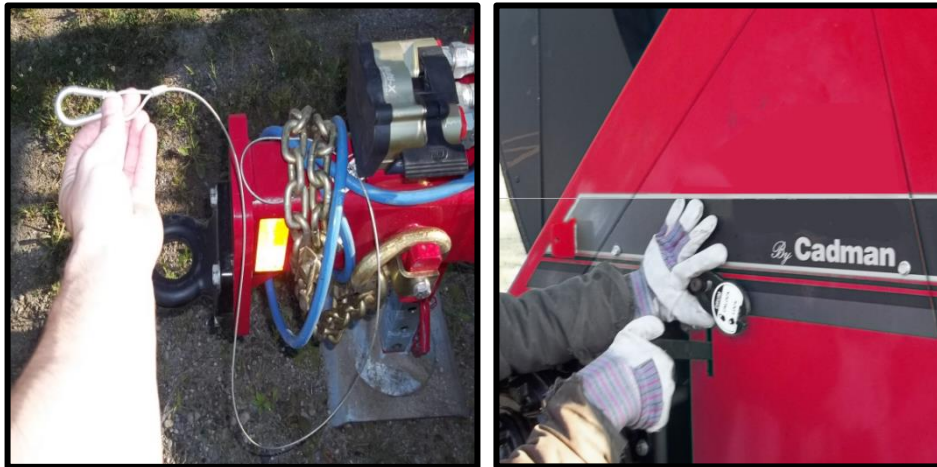

Figure 42 – Connect Break-Away Cable and Lock Prior to Transport

img-00581 & img-00763



It is important to verify that the break-away cable is connected to the back of the vehicle and the lock is engaged prior to moving your **HC10 Soft Hose Caddy**. Failure to do so can result in equipment damage.

Step 3

Ensure the Tongue Brace is in the locked position.

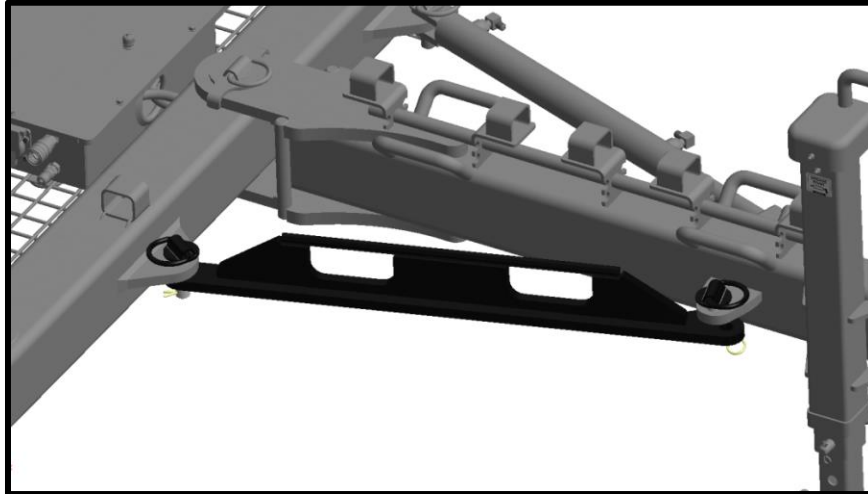

Figure 43 - Tongue Brace in locked Position

img-00584

Step 4

Once at the required site, disengage the drum lock.



Figure 44 - Disengage Drum Lock

img-00763

Step 5

Engage the vehicle hydraulics so the drum rotates towards the vehicle. This will allow the soft hose to unreel. To put the drum into neutral (*free wheel*) shift the vehicles hydraulic controls into the float position.

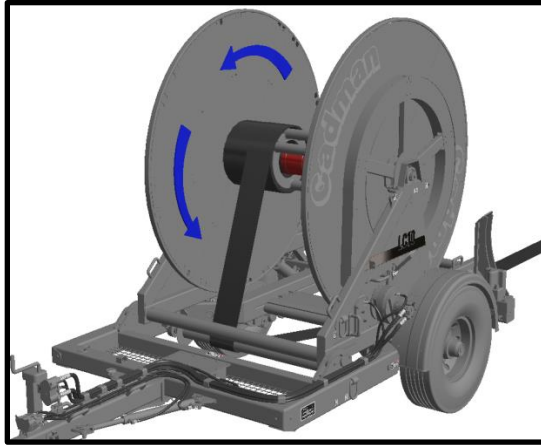

Figure 45 - Unreel Direction

img-00607

As you unreel soft hose, drive the vehicle and hose caddy (at a low rate of speed) along the required hose path.

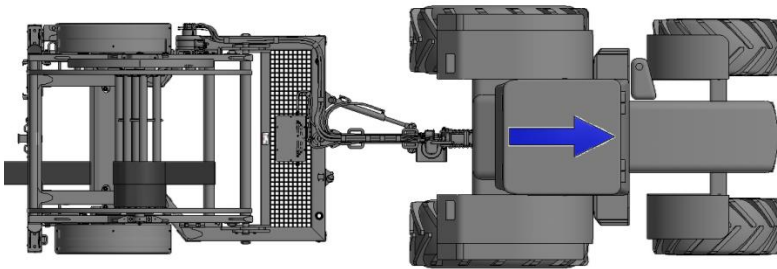

Figure 46 - Unreel Hose Slowly

img-00602

Step 6

When the soft hose is nearing the last wrap stop the tractor and disengage the hydraulics. Slowly rotate the drum so that the hose end fitting can be easily removed manually.



Failure to remove the hose end manually from the Soft Hose Caddy can result in hose, coupler, or drum damage.

OPERATOR NOTE



Where field conditions permit, always attempt to pull the hose either up or down sloping terrain instead of operating across a side hill.

The **Cadman Soft Hose Caddy** allows the operator to offset the tracking of the unit. This allows the hose caddy to be towed to either side of center while unloading the hose. You **MUST** disengage the tongue brace prior to attempting offset tracking.

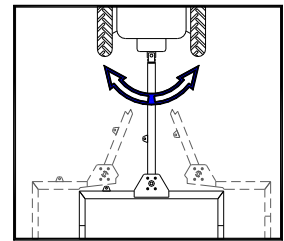

img-00187

When towing the hose caddy in the offset position be aware of obstacles in your path.



Temporary Hose Repair

In some cases your hose may become punctured during regular usage in the field. If this occurs complete the following steps to temporarily repair your hose.

Step 1

Stop pumping fluid through the hose. Wait until all line pressure has dissipated. Or use a pair of hose pinchers to isolate the damaged hose



A hose with a puncture may burst. Stay clear of a hose that is under pressure. Failure to stay clear may result in serious injury.

Step 2

Clean the area with water.

Step 3

Slide the temporary repair sleeve (*optionally equipped on Cadman Supply Hose*) to the damaged area of hose.



Figure 47 - Pull Repair Sleeve

img-00444

Step 4

Pressurize the line.

Step 5

Once you have completed pumping, repair the hose using a hose mender.

Loading Your Hose Caddy from Rear



Prior to loading the HC10 Soft Hose Caddy, Cadman Power Equipment Limited requires that you clean the hoses with a proper clean-out procedure (*i.e. clean-out ball launcher or water flushing*). Failure to do so **WILL** result in gas build up in the hoses creating a great deal of pressure. This can cause equipment failure which could result in serious injury and/or death.

Complete the following instructions to load your Soft Hose Caddy from the rear of the caddy.

Step 1

Position the Soft Hose Caddy relatively straight to the hose end. Disconnect a section of the soft hose by uncoupling the clamp at either end of the section of hose you wish to pick up.



Never pull more than one (1) empty hose at one time. A large amount of damage WILL result to your Hose Caddy.

Step 2

Position the Soft Hose Caddy with the vehicle so that one end of the soft hose can be looped under the front roller then inserted and place parallel with the center of the hub in the hose drum.

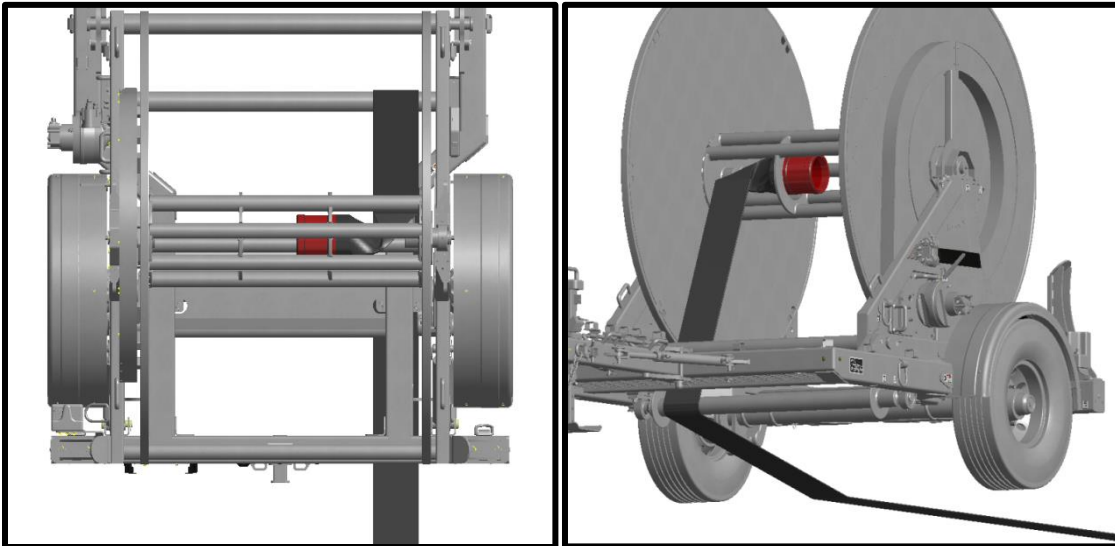

Figure 48 - Insert Hose into Reel and Place Parallel with Hub

img-00587 & img-00765

Step 3

With one end of the hose inserted into the center of the drum, remove the tongue brace and engage the vehicle hydraulics so that the drum rotates away from the vehicle. The soft hose should reel in on the topside of the drum when pulling the hose from the back of the hose caddy to keep tension on the hose.

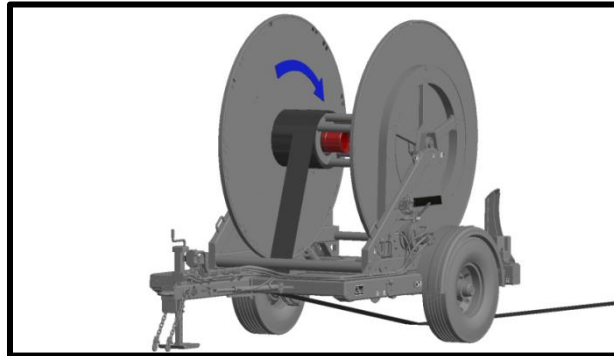

Figure 49 - Reel Direction

img-00766

Step 4

Guide the hose so that it is evenly distributed over the entire reel. Use the cylinder control to index the Soft Hose Caddy left and right to aid in the distribution of the hose.

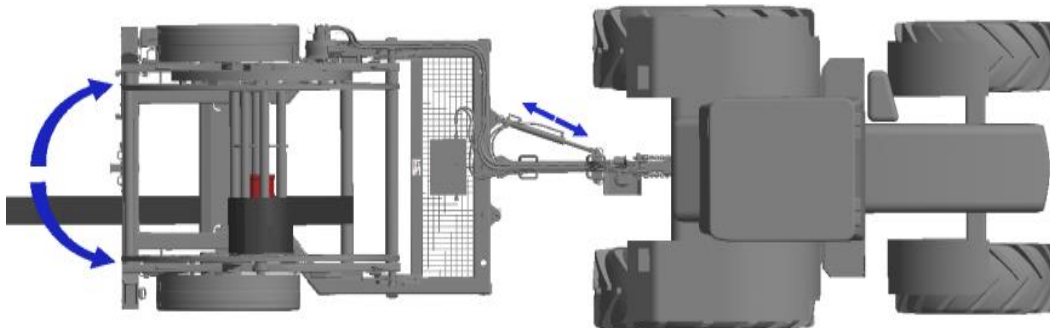

Figure 50 - Index Hose Caddy

img-00601



Do not index the HC10 Soft Hose Caddy with rapid motion. Use small movements to adjust hose distribution. Keep spectators at a safe distance to prevent injury.

Step 5

When the first hose has been retrieved, return to Step 1 for the remaining hoses.

Loading Your Hose Caddy from Front



Prior to loading the HC10 Soft Hose Caddy, Cadman Power Equipment Limited requires that you clean the hoses with a proper clean-out procedure (*i.e. clean-out ball launcher or water flushing*). Failure to do so **WILL** result in gas build up in the hoses creating a great deal of pressure. This can cause equipment failure which could result in serious injury and/or death.

Complete the following instructions to load your Soft Hose Caddy from the front of the caddy.

Step 1

Position the Soft Hose Caddy relatively straight to the hose end. Loading from the front of the caddy you may load as many hoses as you would like at one time without dragging any of the hoses

Step 2

Position the Soft Hose Caddy with the vehicle so that one end of the soft hose can be looped under the front roller then inserted and place parallel with the center of the hub in the hose drum.

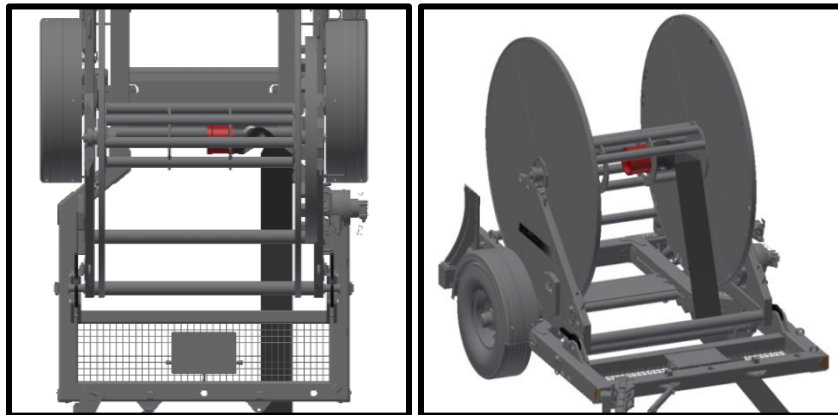

Figure 51 - Insert Hose into Reel and Place Parallel with Hub

img-00604 & img-00767

Step 3

With one end of the hose inserted into the center of drum, remove the tongue brace and engage the vehicle hydraulics so that the drum rotates away from the vehicle. The soft hose should always be reeled in on the topside of the drum. When wrapping the hose put the vehicle in drive and maintain wrap speed do not exceed wrap speed or the hose will not wrap properly.



Figure 52 - Reel Direction

img-00606

Step 4

Guide the hose so that it is evenly distributed over the entire reel. Use the cylinder control to index the Soft Hose Caddy left and right to aid in the distribution of the hose.

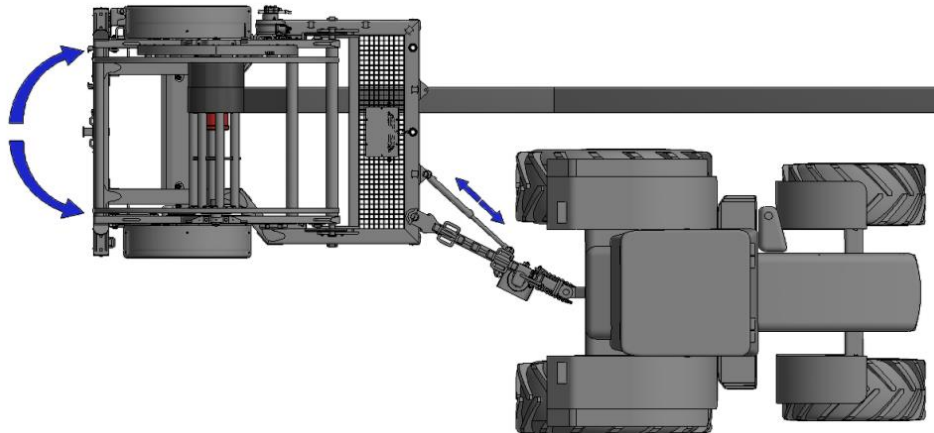

Figure 53 - Index Hose Caddy

img-00603



Do not index the HC10 Soft Hose Caddy with rapid motion. Use small movements to adjust hose distribution. Keep spectators at a safe distance to prevent injury.

Step 5

When the first hose has been retrieved, return to Step 1 for the remaining hoses.

Parts Section

Tongue Assembly.....	32
Trailer Frame Assembly	34
Drum Cartridge Caddy Assembly	37
Drum Assembly	39
Drive Assembly.....	41
Shield/Drum Lock Assembly.....	43
Caddy Hydraulic Assembly.....	45
Trailer Hydraulic Assembly.....	47
Label Assembly	Error! Bookmark not defined.

Symbol Legend

↳	Model Variations
•	Standard Equipment
○	Optional Equipment
◆	Complete Assembly
AR	As Required
N/A	Not Available

Tongue Assembly

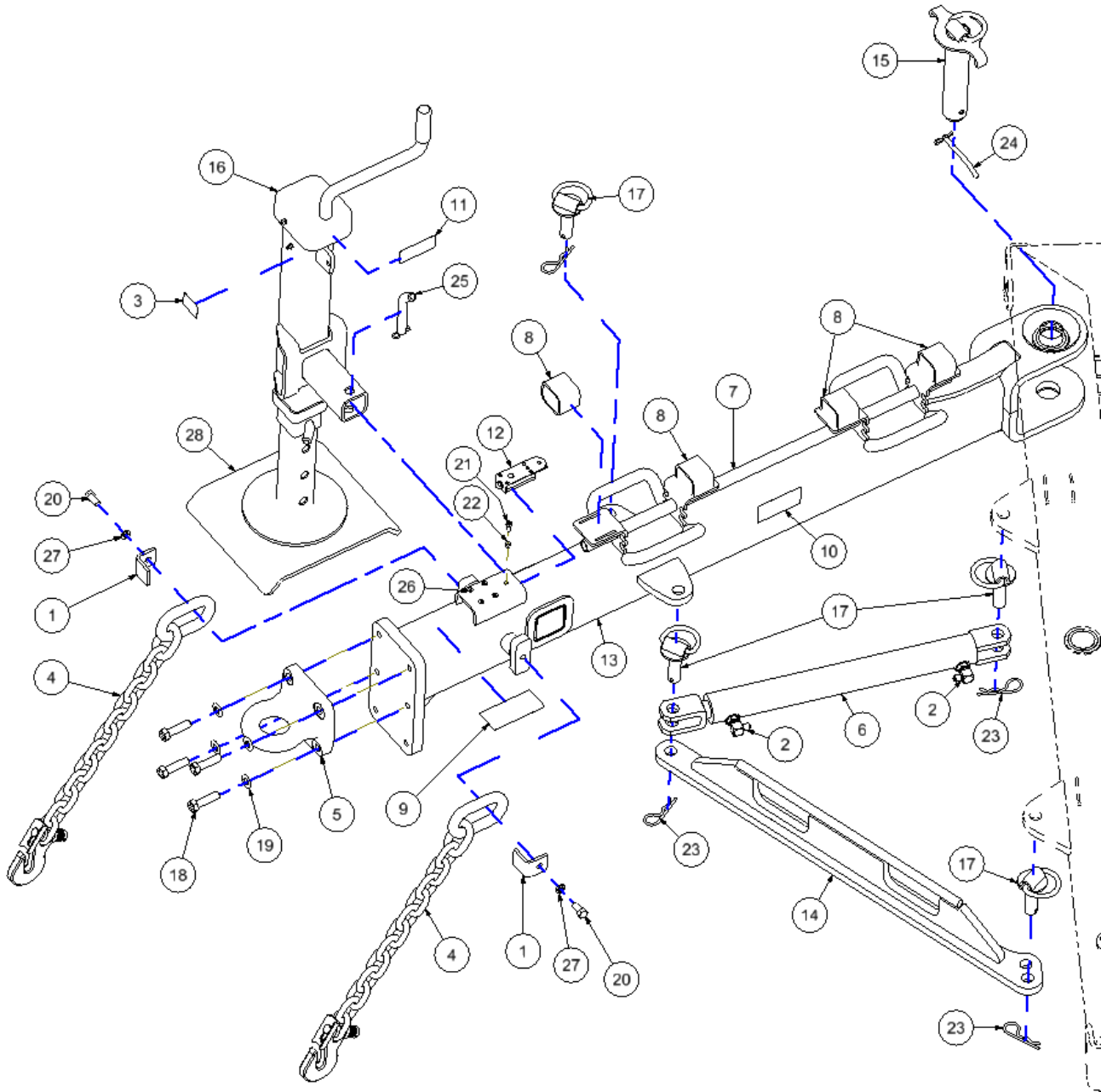

Tongue Assembly

ITEM	DESCRIPTION	PART NUMBER	QTY
1	SAFETY CHAIN RETAINER	17-213	2
2	ELBOW - #6 JIC-M X #8 SAE X 90 DEG.	25-WHD-5515X6X8	2
3	LABEL - GREASE POINT	40-041-A	1
4	SAFETY CHAIN - 20,000 #	40-674	2
5	DRAWBAR - PINTLE EYE - 21 TON 4-BLT	40-859	1
6	CYLINDER - 2.50 X 18.00	40-HYD-CYL001	1
7	CONDUIT - Ø1.00" X 36"	42-505	1
8	STRAP - 2" X 12" VELCRO	42-517	4
9	LABEL - ATTACH BREAK AWAY	42-LBL-035	1
10	LABEL - HEAVY LIFTING	42-LBL-038	2
11	LABEL - HYDRAULIC DOCKING STATION	42-LBL-043	1
12	SWITCH - BREAKAWAY	55-110-SWITCH	1
13	TONGUE WELDMENT - HOSE CADDY	64-201-B	1
14	TONGUE LOCK BAR WELDMENT	64-202	1
15	TONGUE PIN - Ø2" X 9 3/4"	64-600	1
16	TONGUE JACK WELDMENT	64-604	1
17	PIN - CYLINDER	64-605-A	4
18	BOLT GR.8 - 5/8-18 X 2.00	89-BLT-06318X225	4
19	WASHER SAE - 5/8	89-WSR-SAE063	4
20	BOLT - 1/2-13 X 1.00	90-BLT-05013X100	2
21	BOLT FLANGE HEAD - 1/4-20 X 3/4	90-BLT-F02520X075	1
22	NUT LOCK - 1/4-20	90-NUT-LOC025-20	1
23	HAIR PIN - 3/16 X 3 3/4 LG.	90-PIN-HP019X375	4
24	HITCH PIN - 3/8 X 3.00 w/COTTER PIN	90-PIN-HT038X300	1
25	PIN HITCH - Ø3/4" X 3 1/2 w/COTTER PIN	90-PIN-HT075X350	1
26	FLAT HEAD SCREW - M06-100 X 10MM	90-SCR-FHM06100X010	4
27	WASHER LOCK - 1/2	90-WSR-LOC050	2
28	JACK FOOT - WELDMENT	C3-641	1

Trailer Frame Assembly

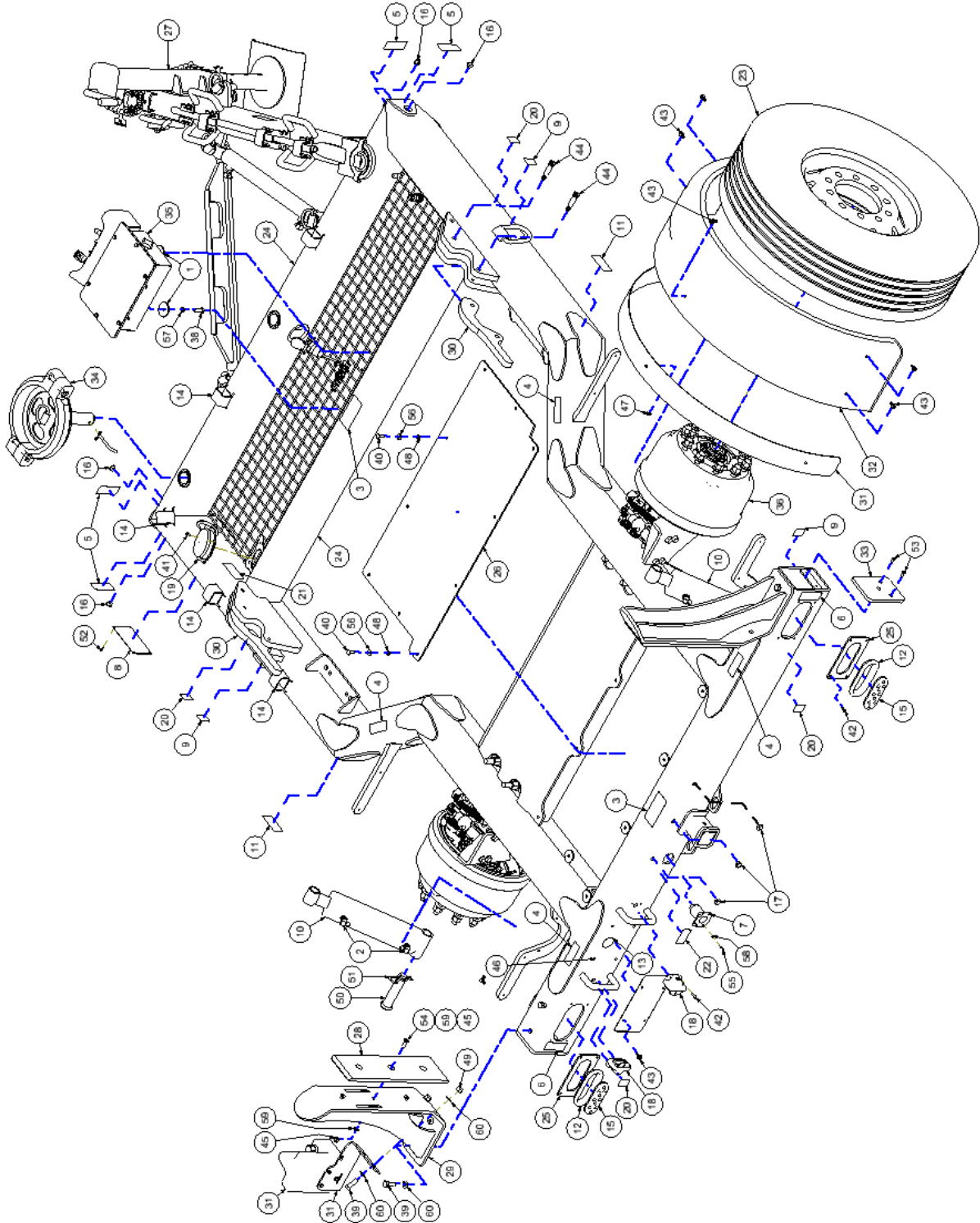

Trailer Frame Assembly

ITEM	DESCRIPTION	PART NUMBER	QTY
1	SPROCKET RETAINING PLATE	01-314-B	2
2	ELBOW - #6 JIC-M X #8 SAE X 90 DEG.	25-WHD-5515X6X8	4
3	LABEL - ROTATING DRUM	40-287-B	2
4	LABEL - PINCH POINT	40-289-A	4
5	DECAL - AMBER REFLECTIVE	40-598	4
6	DECAL - RED REFLECTIVE	40-599	2
7	PLUG - 7-WAY BLADE	40-866	1
8	TAG - TRAILER SERIAL NUMBER	40-881	1
9	LABEL - TIE DOWN POINT	40-947	4
10	CYLINDER ASSY - Ø4" X 10"	40-HYD-CYL002	2
11	LABEL - TORQUE WHEELS	42-035	2
12	GROMMET - OVAL LENSE	42-142	2
13	PLUG - 2" PANEL	42-283	1
14	STRAP - 2" X 12" VELCRO	42-517	5
15	TAIL LIGHT - RED OVAL	42-ELC-006	2
16	MARKER LIGHT - AMBER LED MICRO DOT	42-ELC-007AMB	4
17	MARKER LIGHT - RED LED MICRO DOT	42-ELC-007RED	3
18	LED LICENSE LAMP	42-ELC-008	2
19	GROTE - DOCUMENT HOLDER	42-ELC-012	1
20	LABEL - JACK POINT	42-LBL-021	4
21	LABEL - TRAILER DOCUMENTS	42-LBL-025	1
22	LABEL - TRAILER PLUG	42-LBL-037	1
23	WHEEL ASSY - 315/80R 22.5	55-169	2
24	CARTRIDGE TRAILER WELDMENT	64-100-B	1
25	MOUNT - OVAL TAILLIGHT	64-102	2
26	GUARD PLATE	64-104	1
27	TONGUE ASSEMBLY - LC10T	64-200	1
28	SKID PLATE - HOSE CADDY	64-308	2
29	SKID MOUNT SUPPORT WELDMENT	64-652	2
30	LOCK - CADDY PIVOT	64-654-B	2
31	SUPPORT - FENDER	64-660-A	2
32	FENDER - HALF	64-661-A	2
33	END CAP - BUMPER	64-667-A	2
34	COUPLING DOCK ASSEMBLY - Ø10" HOSE	64-668-1000	1
35	KIT - CONTROL DISTRIBUTION BOX	64-KIT-003	1
36	AXLE ASSEMBLY - HYD BRAKES	64-KIT-006	1



Trailer Frame Assembly Cont.

ITEM	DESCRIPTION	PART NUMBER	QTY
37	LICENSE PLATE	64-PLATE	NA
38	BOLT - 1/2-13 X 1 1/2	90-BLT-05013X150	2
39	BOLT - 5/8-11 X 1 3/4	90-BLT-06311X175	4
40	BOLT CARRIAGE - 3/8-16 X 1 1/4	90-BLT-CG03816X125	10
41	BOLT FLANGE HEAD - 1/4-20 X 0.50	90-BLT-F02520X050	4
42	BOLT FLANGE HEAD - 1/4-20 X 3/4	90-BLT-F02520X075	12
43	BOLT FLANGE HEAD - 3/8-16UNC X 3/4	90-BLT-F03816X075	14
44	BOLT SHOULDER - 5/8-11 X 2 1/4	90-BLT-SH06311X225	4
45	NUT ACORN - 1/2"-13 ZINC	90-NUT-ACN050-13	6
46	THREADED INSERT - 1/4-20 LONG	90-NUT-HTR02520L	4
47	THREADED INSERT - 3/16-18 SHORT	90-NUT-HTR03816S	2
48	NUT LOCK - 3/8-16	90-NUT-LOC038-16	10
49	NUT LOCK - 5/8-11	90-NUT-LOC063-11	2
50	CLEVIS PIN - Ø1 1/2" X 5 5/8" LG.	90-PIN-CL150X563	2
51	HAIR PIN - 1/4 X 5.00 LG.	90-PIN-HP025X500	2
52	RIVET - 3/16 X 5/8 LG.	90-RIV-019X063	4
53	FLAT HEAD SCREW - 5/16-18 X 1	90-SCR-FH03118X100	4
54	FLAT HEAD SCREW - 1/2-13 X 1 1/2	90-SCR-FH05013X150	6
55	SCREW - #10-24 X 3/4 SOCKET CAP	90-SCR-SH01024X075	4
56	WASHER FLAT - 3/8	90-WSR-FLT038	10
57	WASHER LOCK - 1/2	90-WSR-LOC050	2
58	WASHER SAE - #10	90-WSR-SAE010	4
59	WASHER SAE - 1/2	90-WSR-SAE050	6
60	WASHER SAE - 5/8	90-WSR-SAE063	4

Drum Cartridge Caddy Assembly

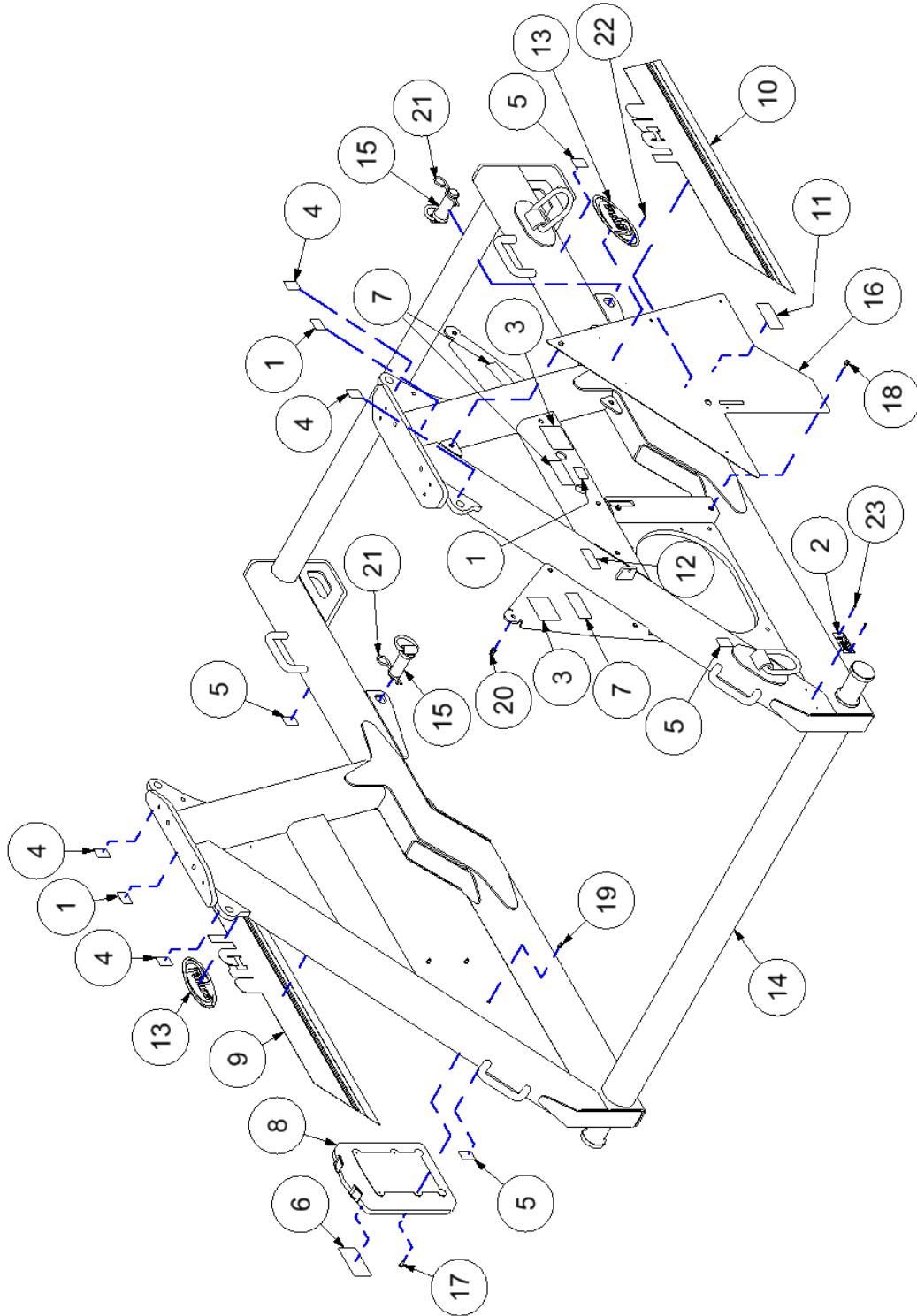



Drum Cartridge Caddy Assembly

ITEM	DESCRIPTION	PART NUMBER	QTY
1	LABEL - GREASE POINT	40-041-A	3
2	CADMAN SERIAL NUMBER TAG	40-238	1
3	LABEL - MOVING PARTS HAZARD	40-290-A	2
4	LABEL - LIFT POINT	40-933	4
5	LABEL - TIE DOWN POINT	40-947	4
6	LABEL - OPERATOR MANUAL	42-050-A	1
7	LABEL - GUARD REMOVED	42-052-A	3
8	MANUAL PAK - LARGE	42-071	1
9	DECAL - HC10 SIDE FRAME L.H.	42-DCL-HC10L	1
10	DECAL - HC10 SIDE FRAME R.H.	42-DCL-HC10R	1
11	LABEL - BRAKE HANDLE	42-LBL-040	1
12	LABEL - HYDRAULIC DOCKING STATION	42-LBL-043	1
13	NAME PLATE - LAYNE	42-NAM-LAYNE	2
14	CARTRIDGE CADDY ASSEMBLY	64-400	1
15	PIN - CYLINDER TOP	64-608-A	2
16	SIDE SKIN - DRIVE SIDE	64-610	1
17	BOLT FLANGE HEAD - 1/4-20 X 3/4	90-BLT-F02520X075	4
18	BOLT FLANGE HEAD - 5/16-18UNC X 3/4	90-BLT-F03118X075	7
19	THREADED INSERT - 1/4-20 SHORT	90-NUT-HTR02520S	4
20	THREADED INSERT - 5/16-18 LONG	90-NUT-HTR03118L	13
21	HAIR PIN - 1/4 X 5.00 LG.	90-PIN-HP025X500	2
22	RIVET - 1/8 X 3/8 LG.	90-RIV-013X038	4
23	RIVET - 3/16 X 3/8 IN	90-RIV-019X038	2

Drum Assembly

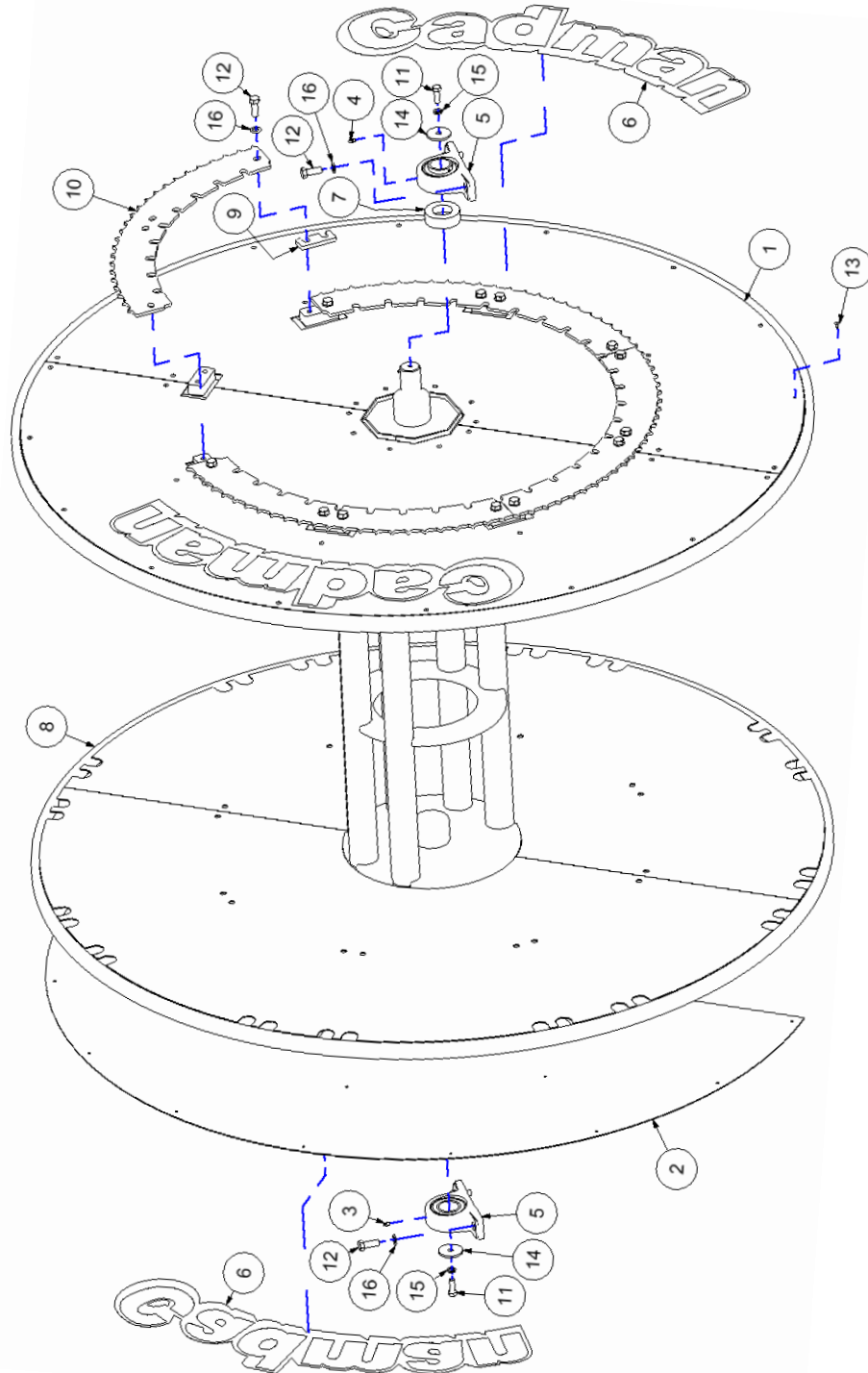



Drum Assembly

ITEM	DESCRIPTION	PART NUMBER	QTY
1	DRUM SKIN - DRIVE SIDE	31-602-A	2
2	DRUM SKIN - NON DRIVE SIDE	31-606	2
3	GREASE FITTING - 1/8 NPT	40-001	1
4	GREASE FITTING - 1/8 NPT 90°	40-001-90	1
5	PILLOW BLOCK BEARING - 2 1/2"	40-602	2
6	DECAL - DRUM R36"	40-DCL-001	4
7	SPACER - DRUM/PILLOW BLOCK	64-306	2
8	DRUM ASSEMBLY - CARTRIDGE CADDY	64-501-A	1
9	SHIM - DRIVE RING	64-615	AR
10	DRIVE SPROCKET - 192 TEETH	64-699-A	4
11	BOLT - 5/8-11 X 1 3/4	90-BLT-06311X175	2
12	BOLT - 3/4-10 X 2.00	90-BLT-07510X200	20
13	RIVET - 3/16 X 7/16 BLACK	90-RIV-019X045BLK	76
14	WASHER FENDER - 5/8 X 3.00	90-WSR-FEN063	2
15	WASHER LOCK - 5/8	90-WSR-LOC063	2
16	WASHER SAE - 3/4	90-WSR-SAE075	20

Drive Assembly

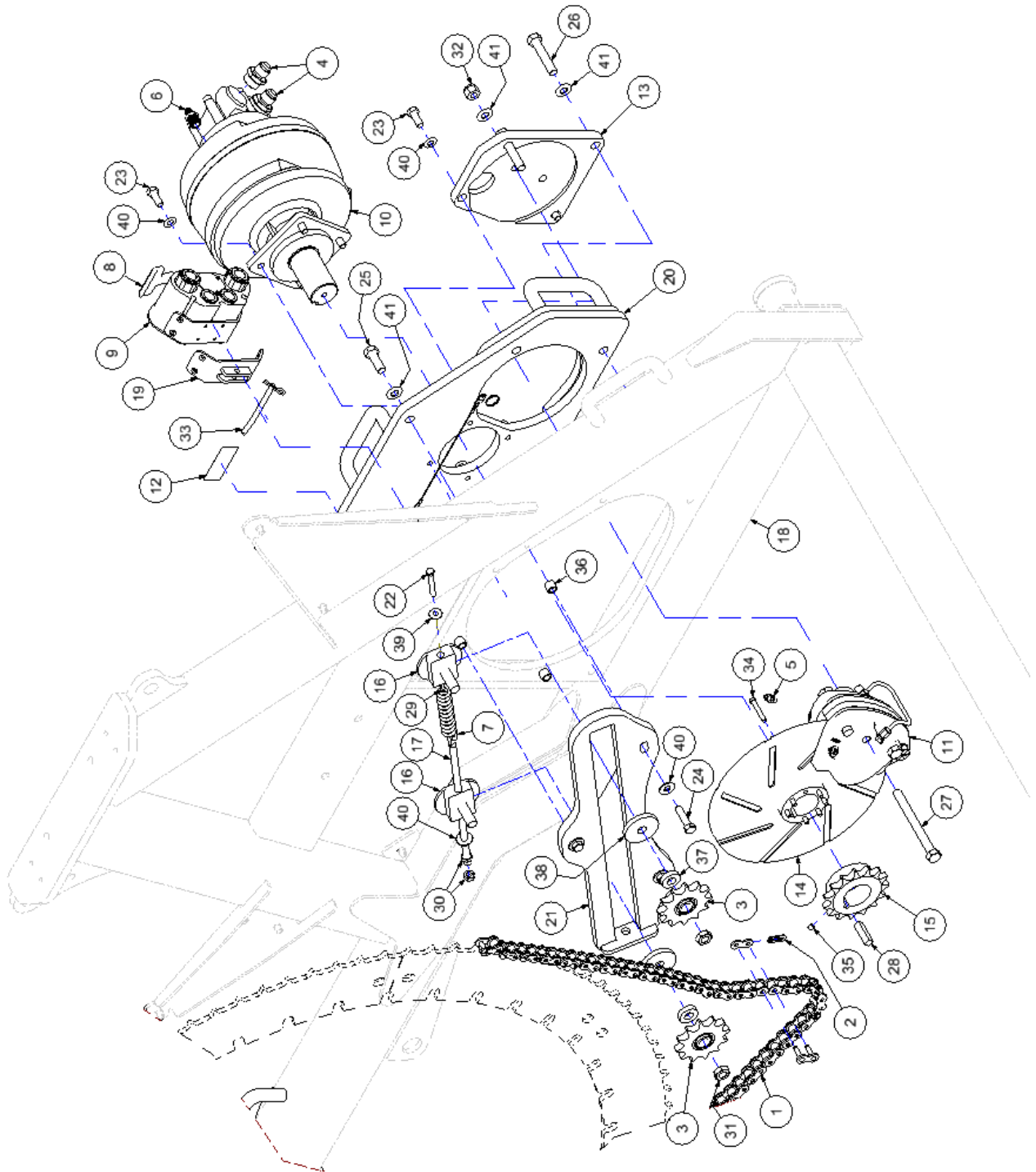



Drive Assembly

ITEM	DESCRIPTION	PART NUMBER	QTY
1	ROLLER CHAIN - #80 RIVETED	10-CHN-80-1RIV	207
2	LINK - #80 CONNECTING	10-LNK-80CONN	1
3	SPROCKET - #80-12 X 3/4 IDLER	10-SPT-80-12IDLER-KN	2
4	ADAPTER - #12 JIC-M X #16 SAE-M	25-WHD-5315X12X16	2
5	ADAPTER - #4 JIC-M X #4 SAE-M	25-WHD-6400X4X4	1
6	ADAPTER - #6 JIC-M X #8 BPS	25-WHD-9002X06X08	1
7	SPRING - 1 3/4 X 5 EXT. (IDLER)	40-056-B	1
8	MULTI-PORT CONNECTOR - 12.5/19 FEMALE	40-HYD-CEJN002F	1
9	DUST COVER - MULTI-PORT 12.5/19 FEMALE	40-HYD-CEJN006	1
10	HYDRAULIC MOTOR	40-HYD-M380CC	1
11	BRAKE CALIPER	42-470	1
12	LABEL - HYDRAULIC DOCKING STATION	42-LBL-043	1
13	MOUNT PLATE - CALIPER	64-303-D	1
14	BRAKE DISC	64-304	1
15	SPROCKET - 80B15X225 MACHINED	64-305-A	1
16	GUIDE - CHAIN IDLER THRU HOLE	64-314-A	2
17	SPRING ADJ. ROD - 9 IN. PLATED	64-315-A	1
18	CARTRIDGE CADDY ASSEMBLY	64-400	1
19	MOUNT - MULTI-PORT CONNECTOR	64-612	1
20	MOTOR MOUNT - CARTRIDGE CADDY	64-651-A	1
21	CHAIN IDLER WELDMENT	64-656-B	1
22	BOLT - 3/8-16 X 2 3/4	90-BLT-03816X275	1
23	BOLT - 1/2-13 X 1 1/4	90-BLT-05013X125	6
24	BOLT - 1/2-13 X 2.00	90-BLT-05013X200	3
25	BOLT - 5/8-11 X 1 3/4	90-BLT-06311X175	3
26	BOLT-5/8-11 X 3.25	90-BLT-06311X325	2
27	BOLT - 5/6-11 X 6 1/2	90-BLT-06311X650	2
28	KEY - 1/2 SQ.	90-KEY-SQ050X200	1
29	NUT EYE - 3/8-16UNC	90-NUT-EYE038-16	1
30	NUT JAM - 1/2-13	90-NUT-JAM050-13	2
31	NUT JAM - 3/4-10	90-NUT-JAM075-10	2
32	NUT LOCK - 5/8-11	90-NUT-LOC063-11	2
33	HITCH PIN - 3/8 X 3.00	90-PIN-HT038X300	1
34	SCREW SOCKET CAP - 5/16-18 X 2.00	90-SCR-SH03118X200	7
35	SET SCREW - 3/8-16 X 3/8	90-SCR-STO3816X038	1
36	SPACER - 0.051" I.D. X 3/4" O.D. X 5/8" LG.	90-SPR-051X075X063	3
37	SPACER - 3/4" I.D. X 1 1/2" O.D. X 3/8" LG.	90-SPR-075X150X038	2
38	SPACER - 3/4" I.D. X 2 3/4" O.D. X 3/8" LG.	90-SPR-075X275X038	2
39	WASHER FLAT - 3/8"	90-WSR-FLT038	1
40	WASHER SAE - 1/2"	90-WSR-SAE050	10
41	WASHER SAE - 5/8"	90-WSR-SAE063	7

Shield/Drum Lock Assembly

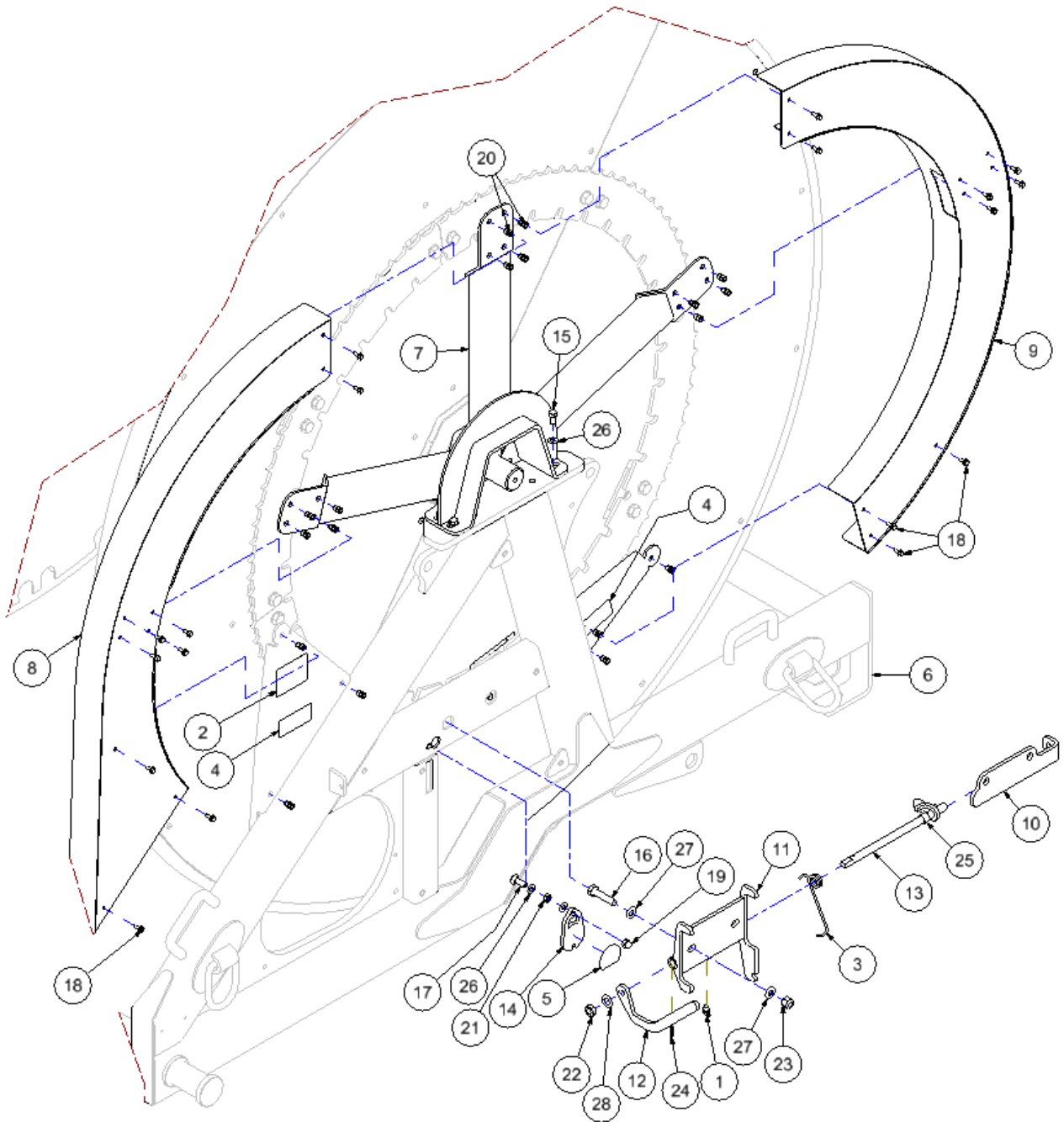



Shield/Drum Lock Assembly

ITEM	DESCRIPTION	PART NUMBER	QTY
1	GREASE FITTING - 1/8 NPT - 45°	40-001-45	1
2	LABEL - MOVING PARTS HAZARD	40-290-A	1
3	SPRING	42-006	1
4	LABEL - GRUAD REMOVED	42-052-A	2
5	LABEL - DRUM LOCK	42-LBL-022	1
6	CARTRIDGE CADDY ASSEMBLY	64-400	1
7	CHAIN GUARD MOUNT WELDMENT	64-601-A	1
8	CHAIN GUARD FRONT WELDMENT	64-602-A	1
9	CHAIN GUARD REAR WELDMENT	64-603-A	1
10	SUPPORT - DRUM LOCK	64-613	1
11	DRUM LOCK BODY WELDMENT	64-662	1
12	HANDLE - DRUM LOCK	64-663-A	1
13	DRUM LOCK WELDMENT	64-664-B	1
14	LOCKOUT BRACKET - DRUM LOCK	64-665-A	1
15	BOLT - 1/2-13 X 1.00	90-BLT-05013X100	4
16	BOLT - 5/8-11 X 2 3/4	90-BLT-06311X275	2
17	BOLT CARRIAGE - 1/2-13 X 1 1/2	90-BLT-CG05013X150	1
18	BOLT FLANGE HEAD - 5/16-18UNC X 3/4	90-BLT-F03118X075	18
19	NUT ACORN - 1/2"-13 ZINC	90-NUT-ACN050-13	1
20	THREADED INSERT - 5/16-18 LONG	90-NUT-HTR03118L	18
21	NUT JAM - 1/2-13	90-NUT-JAM050-13	1
22	NUT JAM - 3/4-10	90-NUT-JAM075-10	1
23	NUT LOCK - 5/8-11	90-NUT-LOC063-11	2
24	PIN ROLL - 1/4 X 1 1/4	90-PIN-RL025X125	1
25	SPACER - 0.080" ID X 15/16" OD X 11/16" LG	90-SPR-080X094X069	1
26	WASHER SAE - 1/2	90-WSR-SAE050	6
27	WASHER SAE - 5/8	90-WSR-SAE063	4
28	WASHER SAE - 3/4	90-WSR-SAE075	1

Caddy Hydraulic Assembly

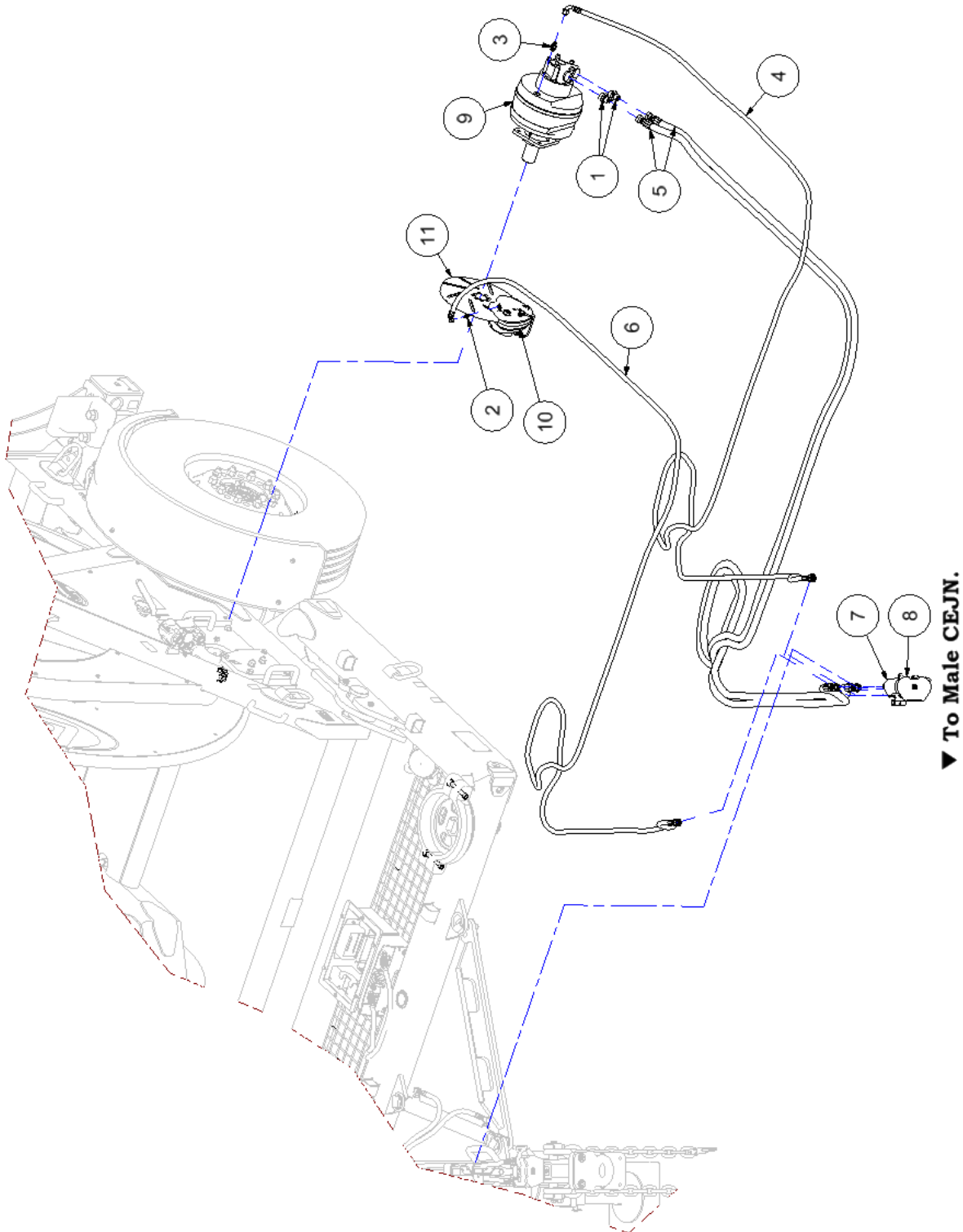



Caddy Hydraulic Assembly

ITEM	DESCRIPTION	PART NUMBER	QTY
1	ADAPTER - #12 JIC-M X #16 SAE-M	25-WHD-5315X12X16	2
2	ADAPTER - #4 JIC-M X #4 SAE-M	25-WHD-6400X4X4	1
3	ADAPTER - #6 JIC-M X #8 BPS	25-WHD-9002X06X08	1
4	240" 3/8" HOSE W 06 JIC-F SW90 X 12 JIC-F SW	40-HHZ-0202	1
5	240" 3/4" HOSE W 12 JIC-F SW X 12 JIC-F SW	40-HHZ-0204	2
6	240" 3/8" HOSE W 04 JIC-F SW 90 X 12 JIC-F SW	40-HHZ-0208	1
7	MULTI-PORT CONNECTOR - 12.5/19 FEMALE	40-HYD-CEJN002F	1
8	DUST COVER - MULTI-PORT 12.5/19 FEMALE	40-HYD-CEJN006	1
9	HYDRAULIC MOTOR	40-HYD-M380CC	1
10	BRAKE CALIBER	42-470	1
11	BRAKE DISC	64-304	1

Trailer Hydraulic Assembly

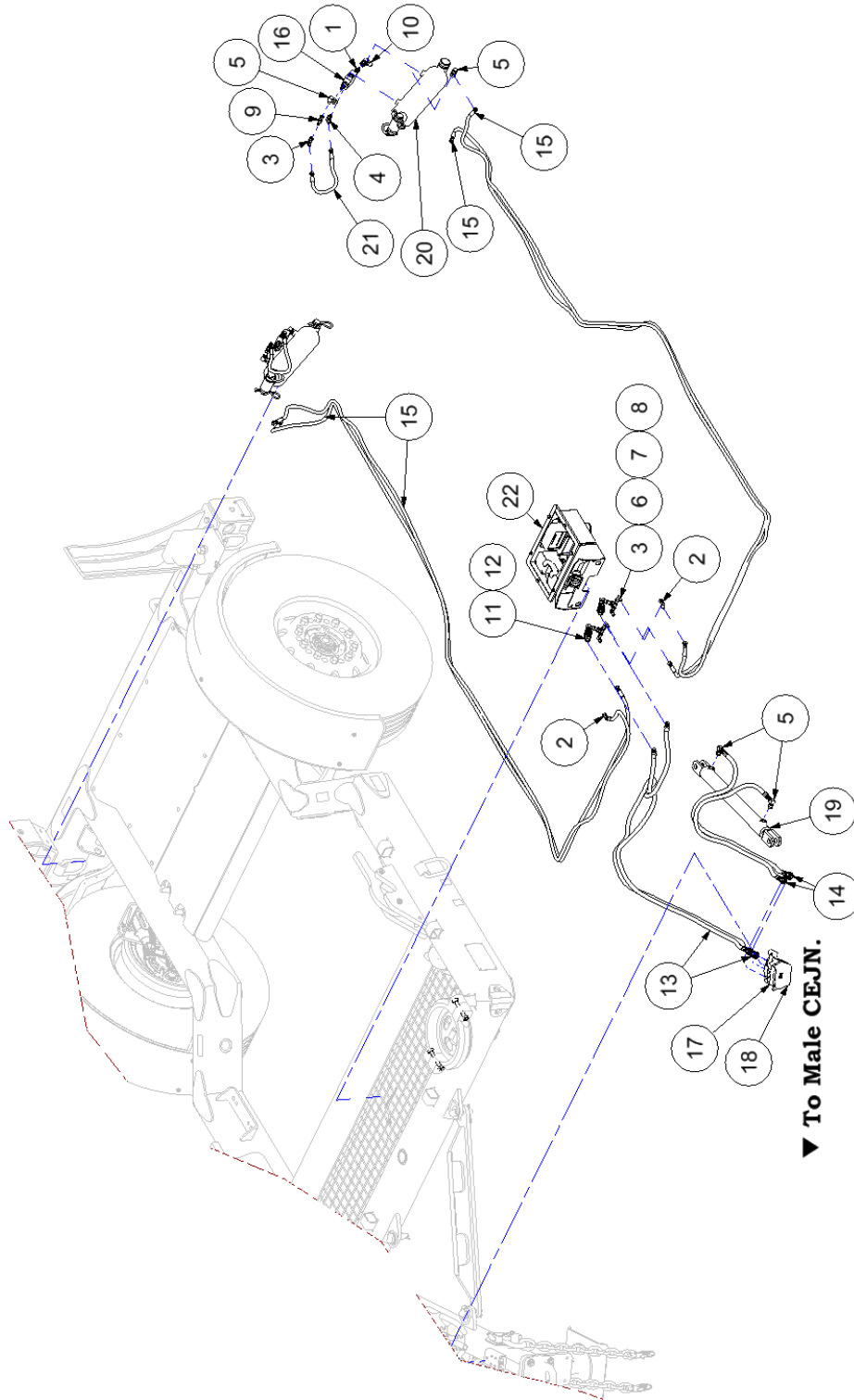

▼ To Male CEJN.



Trailer Hydraulic Assembly

ITEM	DESCRIPTION	PART NUMBER	QTY
1	ADAPTER - #08 SAE-M X #08 JIC-M	25-WHD-5315X8	2
2	ELBOW - #6 JIC 45 SWIVEL	25-WHD-5356X6	2
3	ELBOW - #06 JIC-M X #06 JIC-F X 90	25-WHD-5506X6	6
4	ELBOW - #6 JIC-M X #6 SAE-M X 90	25-WHD-5515X6	2
5	ELBOW - #06 JIC-M X #08 SAE X 90	25-WHD-5515X6X8	6
6	#6 JIC BULKHEAD BRANCH TEE	25-WHD-5725X6	2
7	LOCK NUT - BULKHEAD #6	25-WHD-5924X6	4
8	#6 M-NPT X #6 F-JIC SWIVEL 90 DEG	25-WHD-6501X06X06	2
9	TEE - #06 M-JIC X #06 F-JICSW X #06 M-JIC	25-WHD-6602X06	2
10	ELBOW - #08 SAE-M X #08 F-JICSW X 90	25-WHD-6809X8	2
11	3/8 HYD NIPPLE ISO A STEEL	25-WHD-S561-3	2
12	3/8 HYD COUPLING ISO A STEEL	25-WHD-S565-3	2
13	96IN HOSE W 12 JICF SW X 6 NPTM	40-HHZ-0209	2
14	60IN HOSE W 12 JICF SW X 6 JICF	40-HHZ-0210	2
15	190IN HOSE ASSEMBLY	40-HHZ-0227	4
16	VALVE - COUNTER BALANCE	40-HYD-012	2
17	CEJN MULTI-X QUATRO 12.5 FEMALE	40-HYD-CEJN001F	1
18	CEJN QUATTRO 12.5 FEM. DUST CAP	40-HYD-CEJN005	1
19	HYDRAULIC CYLINDER 2.5 DIA. X 18	40-HYD-CYL001	1
20	CYLINDER ASSEMBLY - 4" X 10"	40-HYD-CYL002	2
21	HYDRAULIC HOSE 1/4 (04)	40-HYD-HOSE025	2
22	KIT - CONTROL DISTRIBUTION BOX	64-KIT-003	1

Required Maintenance

Prevention of mechanical failure is the goal of any good maintenance schedule. The secret to preventing unwanted down time is to adhere to a maintenance schedule suited to the way you use the equipment. Your maintenance schedule should include the following minimum requirements:



Maintenance must be done ONLY when the machine is shut down and is in a non-loaded condition. This means that all mechanical and hydraulic tension has been released from the hose rewind system.

Each Use





MAINTENANCE ITEM	FIGURE	PROCEDURE
Visually inspect equipment		Walk around the unit and inspect for loose, missing or damaged items. Check the condition of tongue pivot pin, chain and connecting links. Replace missing or damaged items and tighten loosened items.
Maintain the tire pressure at Standard 44x18x20 Tire Follow instructions on the wall of the tire. Heavy Duty Option 385/65R22.5 Follow instructions on the wall of the tire.		Using a tire pressure gauge, check the pressure of each tire and add or remove air to achieve the desired pressure.  DO NOT LOWER TIRE PRESSURE BELOW THE RECOMMENDED LEVEL. A lower pressure than the recommended pressure will result in the tire separating from the rim.  DO NOT OVER INFLATE TIRE. Pressure higher than recommended will result in wheel failure which could result in serious injury and/or death.
Tighten all wheel bolts		Before moving the unit, verify that the wheel bolts are tight. When tightening the Grade 8 lug nuts use the star pattern with your torque wrench set at 450-500 ft/lbs [610-678 N.m] lubricated and 600-670 [813 – 908 N.m] dry.
Adjust the alignment and tension of drive chains	Figure	The drive chain (around the drum) is properly tensioned when it has no visible slack and is setting properly onto the drive sprocket when the drum rotates. Adjustments are made by turning the locknut (3/4" wrench) on the spring adjustment rod.
Lubricate all grease fittings and check axle oil level	Figure	Using a grease gun, lubricate all grease fittings with an appropriate amount of acceptable grease. (See Lubricants)
Check electrical connection	Figure	Check the main electrical connection before operating to make sure it is fully connected. Failure to do so will result in the emergency brake system not functioning. Lubricate with dielectric grease

Table 1 - Required Maintenance - Each Use

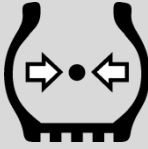
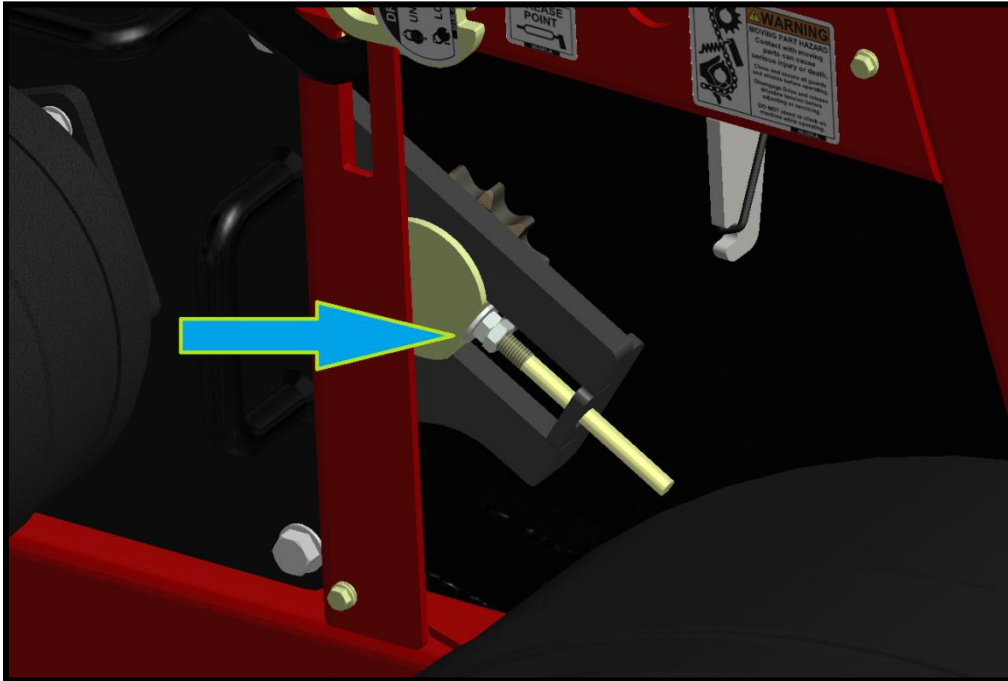

Figure 54 - Drive Chain Adjuster (Drive side inside frame)

img-00585

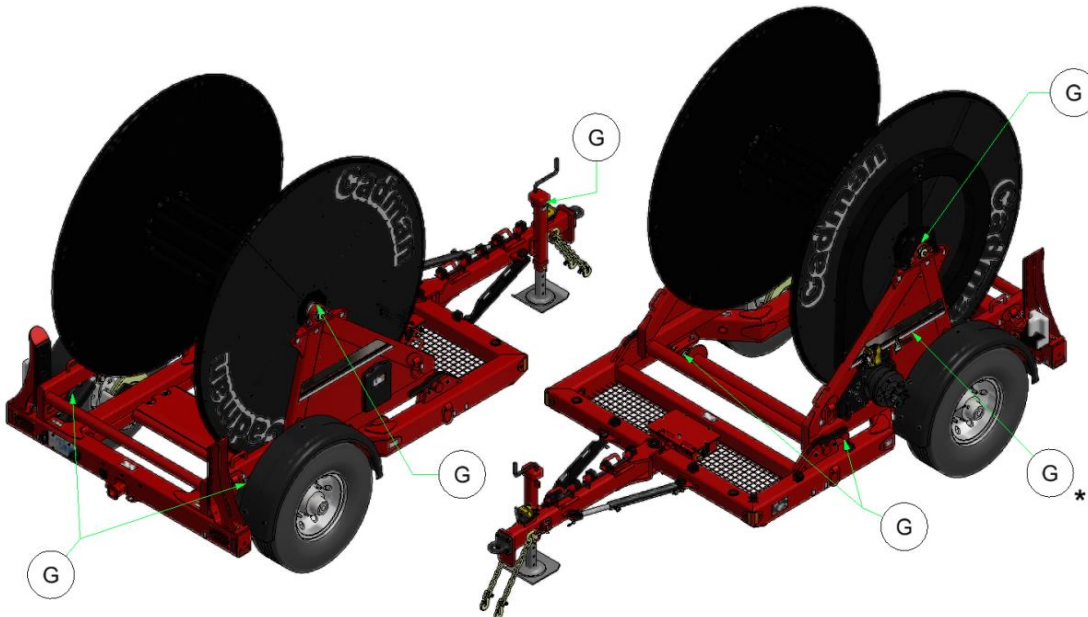

Figure 55 - Grease Points (*Behind Shield)

img-00769



Prior to moving the HC10 Soft Hose Caddy, Cadman Power Equipment Limited requires that you hook up the electrical connection at the hydraulic box as well as the break-away cable to the vehicle. Failure to do so **WILL** result in the emergency brakes not to come on in the event of trailer break-away. This can cause damage to the equipment and/or could result in serious injury and/or death.

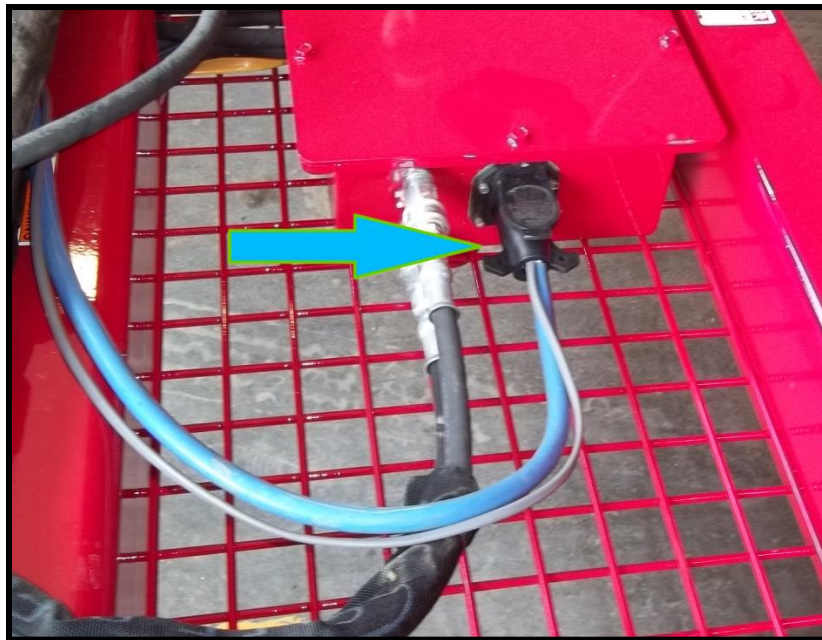

Figure 56 – Electrical Connection

img-00586

Before Storing



Prior to storing the **Soft Hose Caddy**, **Cadman Power Equipment Limited** requires that you clean the hoses with a proper clean-out procedure (i.e. clean-out ball launcher or water flushing). Failure to do so **WILL** result in gas build up in the hoses creating a great deal of pressure. This can cause equipment failure which could result in serious injury and/or death.

MAINTENANCE ITEM	FIGURE	PROCEDURE
Drain and clean out the hose.	N / A	Use a clean-out ball (sold separately) following the instructions provided with the unit. OR Flush with water (minimum of 2000 gallons [7600 liters]) to completely purge the hose.
Clean, inspect, and repack the main chassis wheel bearing.	N / A	Replace the seals as required
Lubricate all grease points.	Figure	Using a grease gun, lubricate all grease fittings with an appropriate amount of grease. (See Lubricants)
Lubricate all chains	N / A	Brush each chain with grease. (See Lubricants)

Table 2 – Required Maintenance - Before Storing

Before Start Up (After long term storage)

MAINTENANCE ITEM	FIGURE	PROCEDURE
Review Operator's manual		Review this manual to refresh your memory regarding the proper operation of this machine. This will reduce the potential for equipment damage and user injury.
Complete each use maintenance	Table 1	Complete all the maintenance procedures as prescribed in the Each Use maintenance table.

Table 3 – Required Maintenance - After Long Term Storage

Lubricants

Grease: Any good grade multi-purpose, waterproof grease is compatible with the requirements of your **Cadman HC10 Soft Hose Caddy**.

Axle Oil: 80W90 mineral oil and 75W90 synthetic oil are compatible with the requirements of your **Cadman HC10 Soft Hose Caddy**.

Technical Specifications

IMPORTANT: The dimensions shown on the following pages are only approximate. Many varying factors affect these dimensions, for example tire option, hose type, tire inflation etc.

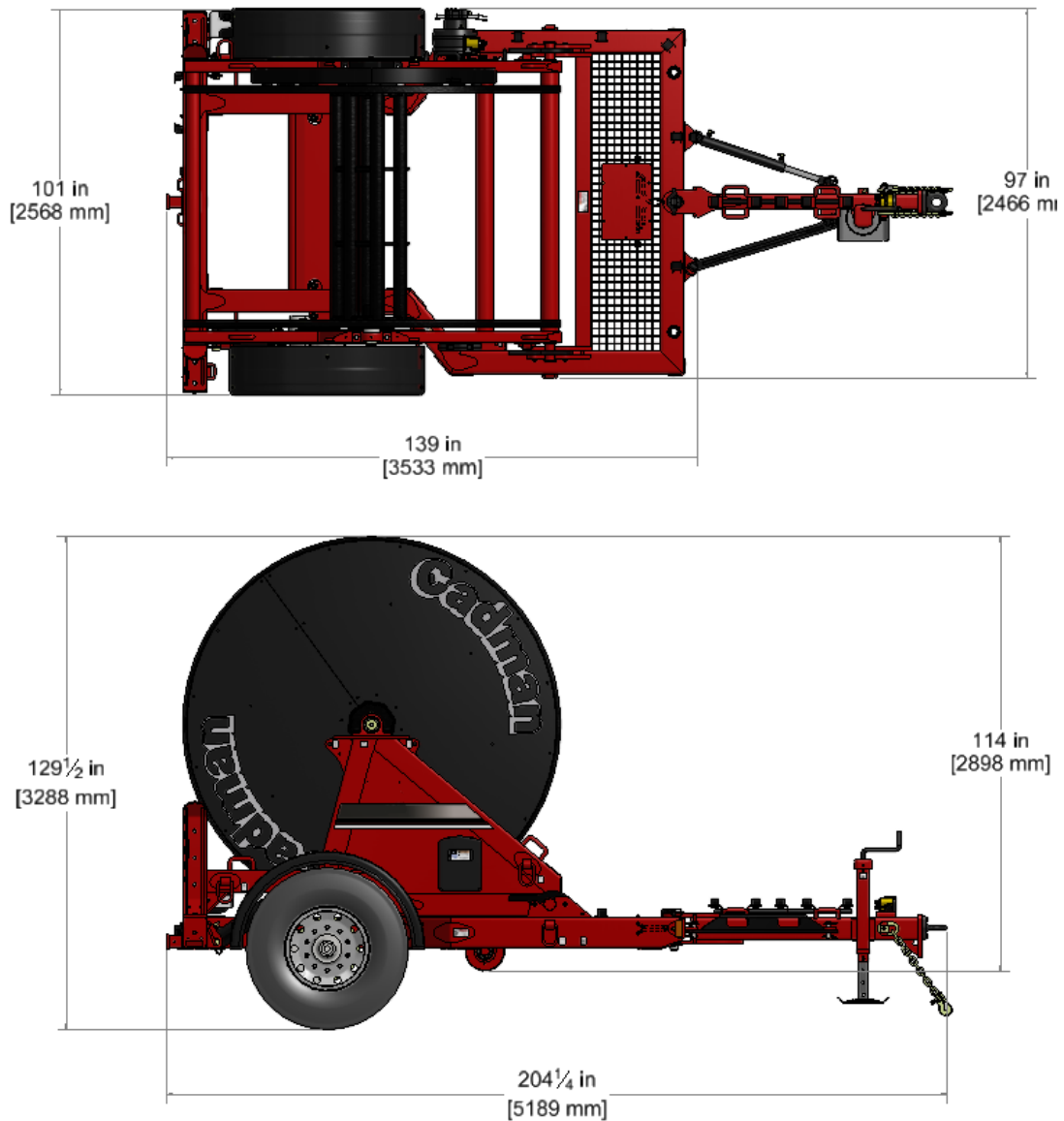

Figure 57 - Overall Dimensions

img-00764

The approximate weight of an empty Cadman HC10 Hose Caddy is 6,856 lbs [3,110 kg].

HC10 Soft Hose Caddy Trailer Dimensions

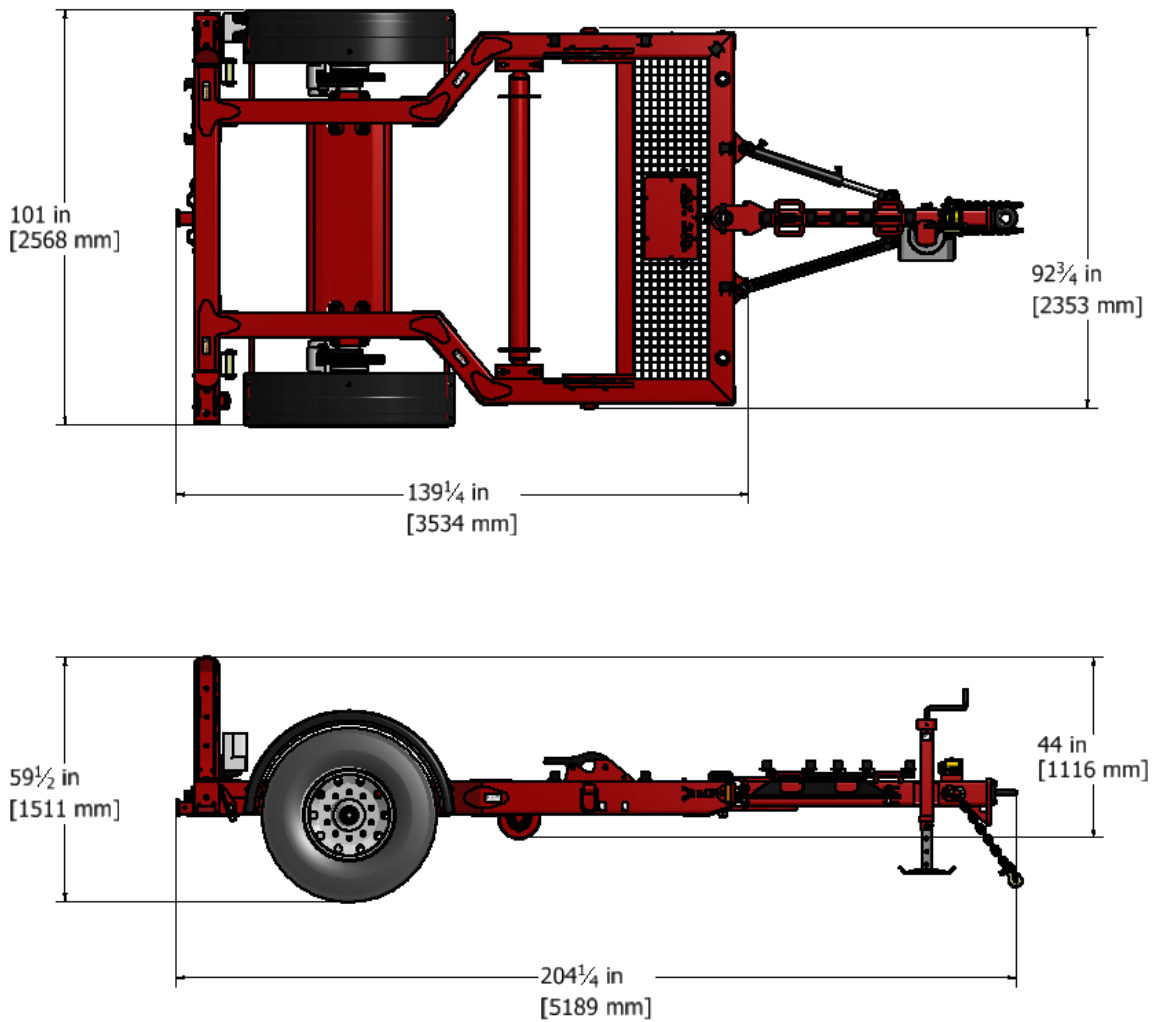

Figure 58 - Overall Trailer Dimensions

img-00573

The approximate weight of an empty Cadman HC10T Trailer is 3,780 lbs [1,714 kg].

HC10 Soft Hose Caddy Cartridge Dimensions

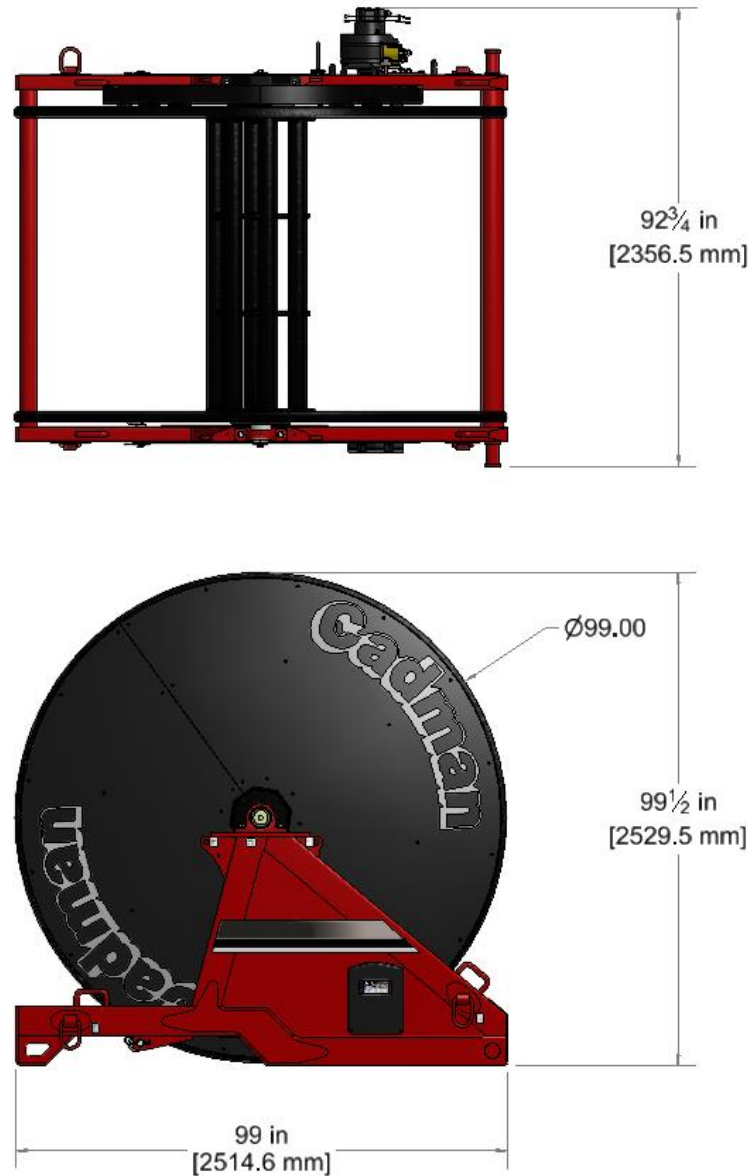

Figure 59 - Overall Cartridge Dimensions

img-00764

The approximate weight of an empty Cadman HC10 Cartridge is 3,078 lbs [1396 kg].

HC10 Soft Hose Caddy Trailer Tongue Positions



Prior to changing the HC10 hose caddy trailer tongue position the machine must be shut down and in a non-loaded condition. This means that all mechanical and hydraulic tension has been released from the hydraulic hose system.

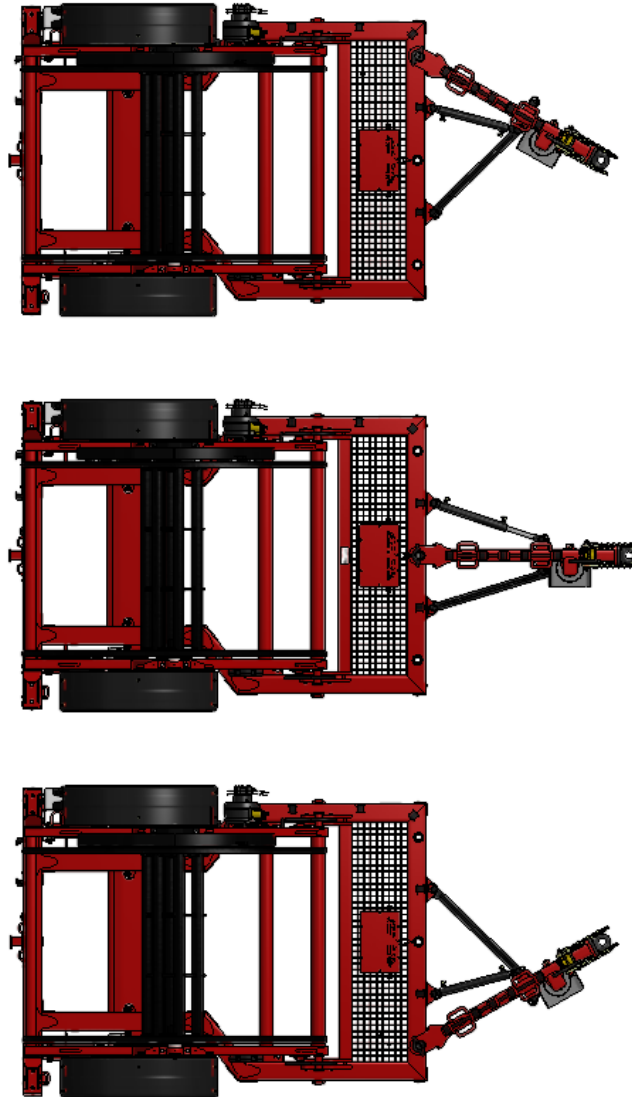

Figure 60 - Different Tongue Positions

img-00579

Useful Information

LENGTH

1 FOOT	= 12	Inches	1 METER	= 39.37	Inches
	= 0.3048	Meter		= 3.2808	Feet
1 ROD	= 198	Inches	1 MILE	= 5280	Feet
	= 16.5	Feet		= 1760	Yards
	= 5.5	Yards		= 320	Rods
	= 5.029	Meters		= 1609	Meters

AREA

1 SQUARE FOOT	= 144	Square Inches
	= 0.0929	Square Meters
1 SQUARE YARD	= 1296	Square Inches
	= 0.8361	Square Meters
1 SQUARE METER	= 1550	Square Inches
	= 10.764	Square Feet
1 ACRE	= 43560	Square Feet
	= 4047	Square Meters
	= 0.4047	Hectare
1 HECTARE	= 107639	Square Feet
	= 10000	Square Meters
	= 2.47105	Acres
1 SQUARE MILE	= 640	Acres
	= 259	Hectares

VOLUME

1 GALLON (US)	= 0.8327	Imperial Gallons
	= 231	Cubic Inches
	= 0.1337	Cubic Feet
	= 8.345	Pounds
1 CUBIC FOOT	= 1728	Cubic Inches
	= 7.48	Gallons (US)
	= 62.4	Pounds
	= 28.32	Liters
1 ACRE INCH	= 27154	Gallons (US)
	= 254	Cubic Meters / Hectare
AREA OF A CIRCLE	= Diameter x Diameter x 0.7854	
CYLINDER VOLUME (US GAL.)	= Diameter (ft.) x Diameter (ft.) x Length (ft.) x 5.8752	

